

Technical and Bibliographic Notes / Notes techniques et bibliographiques

The Institute has attempted to obtain the best original copy available for filming. Features of this copy which may be bibliographically unique, which may alter any of the images in the reproduction, or which may significantly change the usual method of filming, are checked below.

L'Institut a microfilmé le meilleur exemplaire qu'il lui a été possible de se procurer. Les détails de cet exemplaire qui sont peut-être uniques du point de vue bibliographique, qui peuvent modifier une image reproduite, ou qui peuvent exiger une modification dans la méthode normale de filmage sont indiqués ci-dessous.

Coloured covers/  
Couverture de couleur

Covers damaged/  
Couverture endommagée

Covers restored and/or laminated/  
Couverture restaurée et/ou pelliculée

Cover title missing/  
Le titre de couverture manque

Coloured maps/  
Cartes géographiques en couleur

Coloured ink (i.e. other than blue or black)/  
Encre de couleur (i.e. autre que bleue ou noire)

Coloured plates and/or illustrations/  
Planches et/ou illustrations en couleur

Bound with other material/  
Relié avec d'autres documents

Tight binding may cause shadows or distortion along interior margin/  
La reliure serrée peut causer de l'ombre ou de la distorsion le long de la marge intérieure

Blank leaves added during restoration may appear within the text. Whenever possible, these have been omitted from filming/  
Il se peut que certaines pages blanches ajoutées lors d'une restauration apparaissent dans le texte, mais, lorsque cela était possible, ces pages n'ont pas été filmées.

Coloured pages/  
Pages de couleur

Pages damaged/  
Pages endommagées

Pages restored and/or laminated/  
Pages restaurées et/ou pelliculées

Pages discoloured, stained or foxed/  
Pages décolorées, tachetées ou piquées

Pages detached/  
Pages détachées

Showthrough/  
Transparence

Quality of print varies/  
Qualité inégale de l'impression

Continuous pagination/  
Pagination continue

Includes index(es)/  
Comprend un (des) index

Title on header taken from:/  
Le titre de l'en-tête provient:

Title page of issue/  
Page de titre de la livraison

Caption of issue/  
Titre de départ de la livraison

Masthead/  
Générique (périodiques) de la livraison

Additional comments:/  
Commentaires supplémentaires:

Pagination is as follows: 1-2, 23-44, 3-14.

This item is filmed at the reduction ratio checked below/  
Ce document est filmé au taux de réduction indiqué ci-dessous.

10X	12X	14X	16X	18X	20X	22X	24X	26X	28X	30X	32X
								✓			

# CANADIAN JOURNAL OF Fabrics

THE JOURNAL OF THE  
Textile Trades of Canada.

Vol. XXI.

TORONTO AND MONTREAL, FEBRUARY, 1904.

No. 2.

## WILSON, PATERSON & Co.

30 St. John Street, Montreal,  
REPRESENTING IN CANADA

The United Alkali Company of England.



OFFER TO THE TRADE—

Caustic Soda, 50° to 78°, Caustic Potash, Salt Cake, Salsoda,  
Soda Ash (Ammonia and Leblanc processes),—Chlorate of Soda,  
Chlorate of Potash, Hyposulphite of Soda (Curlew Brand),  
Chloride of Calcium, Bichromate of Soda, Bichromate of Potash,  
etc., etc.

## McARTHUR, CORNEILLE & CO.

Importers and  
Manufacturers of

 **OILS** . . . . .  
**CHEMICALS**

and **DYE**

810 to 816 St. Paul St.

**MONTREAL . . . . . STUFFS**

## ANILINES ALIZARINES

DOMINION DYEWOOD & CHEMICAL CO.

TORONTO

Direct Importers. Sole Agents in Canada for

Messrs. The FARBENFABRIKEN Vormals FRIEDR BAYER  
& CO., Elberfeld, Germany.

## WATSON JACK & COMPANY, MONTREAL.

ANILINES and DYESTUFFS.

**Chrome Acid Colors.**  
**Excellent on Yarn or Pieces**

Send for dyed Samples illustrating their  
great utility.

## New York and Boston Dyewood Co.

MANUFACTURERS OF

## DYEWOOD Extracts

Importers of INDIGO AND ANILINE COLORS.

SELLING AGENT IN CANADA

A. W. LEITCH, 16 Hughson St. South, Hamilton, Ont.

## CASSELLA COLOR COMPANY.

(American Branch of  
Leopold Cassella & Co.)

## Artificial Dye Stuffs

NEW YORK, 182-184 Front Street

BOSTON, 68 Essex Street.

PHILADELPHIA, 126-128 South Front Street.

PROVIDENCE, 64 Exchange Place.

ATLANTA, 47 North Pryor Street.

MONTREAL, 86-88 Youville Square.

## W. T. BENSON & CO.

ANILINE COLOURS

DYEWOOD EXTRACTS

CHEMICALS, &C., &C.

Specialties:

**Logwood for Cotton and Wool.**

**Fast Onedip Cotton Dyes.**

**Alizarines & Azo-Alizarines.**

164 St. James St., Montreal

## Logwood Extracts

IN PASTE AND POWDER

Purest and Cheapest in the Market.

Manufactured right on the ground.

The West Indies Chemical Works, Limited,

Spanish Town, - Jamaica.

Bellhouse, Dillon & Co.

Sole Agents

MONTREAL. TORONTO. NEW YORK. PHILADELPHIA.

USE THE  
**"Halton"**  
 Jacquard

BEST MACHINE ON THE MARKET

Single Lifts  
 Double Lifts  
 Rise and Falls  
 Double Cylinders  
 Cross Borders  
 Brussels

The only  
 Reliable  
 Fine  
 Index  
 Machine.

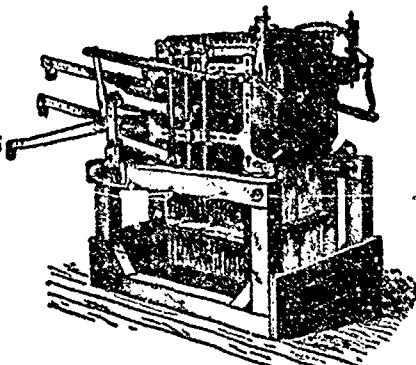

"1304" Fine Index  
 Double Lift.

**Thomas Halton's Sons**

Alleghany Avenue and C. Street, - PHILADELPHIA

New York Boston Philadelphia Providence Chicago Montreal

**C. BISCHOFF & CO.**

IMPORTERS OF

**Aniline Colors and Alizarines**

**Dye-Stuffs and Chemicals**

Main Office, 88 Park Place, - - New York.  
 Canadian Branch, 416 St. Paul St., Montreal.

**YARNS**

**W. M. CROWE,**  
 28-30 Wellington St. W.,  
 TORONTO

Sole  
 Agent  
 For  
 Canada

Specially representing:-

Messrs. John Smith & Sons, Ltd., Bradford, Eng., Worsted Yarns.  
 Messrs. Wm. Hollins & Co., Ltd., Nottingham, Eng., Worsted and  
 Merino Yarns.  
 Mr. J. C. Horsfall, Cross Hills, Eng., Knitting Yarns.  
 Mr. J. H. Willey, Bradford, Eng., Fancy Loops and other effect  
 Yarns in Worsted and Mohair.  
 Messrs. Aykroyd & Grandage, Ltd., of the Bradford Dyers' Associa-  
 tion, Mercerized Cotton Yarns.

**Knitting Manufacturers**

will find great satis-  
 faction in using

**HORSFALL'S RENOWNED HAYFIELD KNITTING YARNS**  
 FOR SWEATERS AND HOSIERY.

**GARLAND MFG. CO.,**

**SACO, MAINE.**

(Formerly Loom Picker Co., Biddeford, Maine).

H. P. GARLAND, TREASURER.

MANUFACTURERS OF

Rawhide and Leather Loom Pickers,  
 Loom Harnesses and Reeds,  
 Duck and Ticking Lug Straps,  
 Tape Picker Loops, Leather Strapping,  
 Black Oak-Tanned English Picker Leather,  
 North Carolina Hickory Picker Sticks.

Illustrated Catalogue sent on application.

PEROXIDE OF SODIUM BLEACHES

**"White  
 Without  
 Weakening"**

THE ROESSLER & HASSLACHER  
 CHEMICAL CO. 100 WILLIAM ST. NEW YORK.

**ROBERT S. FRASER**

**Wools, Peruvian Cottons,  
 Noils, Tops, Yarns, Etc.**

**Tetlow's Card Clothing.**

(STOCK IN MONTREAL).

Manufacturers of Wastes and Shoddies.

17 Lemoine Street, - - - MONTREAL

**Mechanical Draft Apparatus.  
 Heaters and Fans.  
 Blowers and Exhausters.**

Drying Apparatus for all Textile Materials.  
 Heating and Ventilating for Mills and Factories.

For Catalogues and Prices write-

**SHELDON & SHELDON,**

CALY, Ontario, Canada.

Formerly McEachren Heating & Ventilating Co.

# CANADIAN Journal of Fabrics

THE JOURNAL OF THE Textile Trades of Canada.

Vol. XXI.

TORONTO AND MONTREAL, FEBRUARY, 1904.

No. 2.

## Canadian Journal of Fabrics

A Monthly Journal devoted to Textile manufactures and the Dry Goods and kindred trades.

Subscription: Canada, United States and Great Britain, \$1.00 per year foreign, 50c. Advertising rates on application

Offices: 18 Court St., cor. Church, Toronto, and the Fraser Building, Montreal

**BIGGAR-SAMUEL, LIMITED, Publishers**

TRAVELLING REPRESENTATIVE, A. W. SMITH.

Toronto Telephone, Main 4310 | Montreal Telephone, Main 2589

Business correspondence should be addressed to Montreal; but cuts, news items and editorial correspondence to Toronto; cuts from abroad should be sent by post wherever possible, not by express. Changes of advertisements should be in our hands not later than the 10th of each month to ensure insertion.

### THE CANADIAN TEXTILE DIRECTORY

A Handbook of all the Cotton, Woolen and other Textile manufactures of Canada, with lists of manufacturers' agents and the wholesale and retail dry goods and kindred trades of the Dominion, to which is appended a vast amount of valuable statistics relating to these trades. Fourth edition. Price, \$3.00.

**BIGGAR-SAMUEL, LIMITED, Publishers.**

### CONTENTS OF THIS NUMBER.

British Textiles, Last Year's .. 31	Oiled Wools .. 41
" Textile trade with Canada .. 30	Postal Policy, Imperial .. 24
" Woolen Exports .. 30	Russo-Japanese War, The .. 25
Brussels and Winton Carpets .. 36	Sheep Breeding in Cape Breton .. 41
Companies, New .. 39	Steam Turbines in Textile Mills .. 41
Cotton, German Colonial .. 42	Westinghouse .. 30
" Growing .. 23	Textile Situation in Britain, The .. 26
" In Dutch Borneo .. 43	" Trade of Almonte Ont., ad page 6
Dry Goods Section, Toronto Board .. 38	War and the Silk and Cotton .. 30
of Trade .. 38	Market, The .. 30
Dyeing Machine, Centrifugal .. 28	Wool Fibre, Origin .. Structure .. 38
Fabric Items .. 28	Composition, and Properties .. 38
Fibre from the Straits Settlement, Murva .. 39	Woolen Industry, The .. 42
Markets, Wool .. ad page 6	" Manufacturing in Nova Scotia .. 42
Metric System, The .. 43	Wool Sales .. ad page 6
Mills, Among the .. 27	

### COTTON GROWING.

One authority states that the profits over the average received by the cotton growers of the Southern States during the past year amount to \$100,000,000. It is not surprising that the acreage in cotton during the present year will be increased to the fullest extent possible, the Southern planters abandoning other crops for cotton. It is not surprising, moreover, that keen attention is being given to the possibilities of cotton growing not only in the British colonies throughout the world, but in the colonies of Germany, France, Portugal and Italy, while Russia is putting forth efforts to develop new cotton fields in her Asiatic possessions. The methodical and persevering Germans have formed a "Colonial Economic Com-

mittee," under the auspices of which the experiments in Togoland, previously described in this journal, are being extended to other German African settlements. The German Consul at Galveston, Texas, is to supervise a plan for training young Germans in the art of cotton cultivation in the States with a view to their becoming pioneers in the same work in German colonies. France, as well as Great Britain, now realizes that if cotton manufacturing in the United States develops much more all the raw material produced in the States will be required for home consumption, and that French cotton mills, to be safe, must provide new fields. To this end the Government is encouraging the formation of syndicates for cotton growing in the French West African colonies.

The information given from time to time, as to extension of cotton growing areas in the British colonies, shows that the cotton manufacturers of the Empire are now quite alive to the risks run in permitting themselves to be dependent upon supplies from a single country, and they are equally alive to the direct, as well as the indirect, advantages of having their raw material produced in lands under the British flag. J. W. Mollison, Inspector-General of Agriculture in India, is engaged on experiments to determine the possibilities of increasing the quality, as well as the amount, of Indian cotton. British Africa, north and south, offers a wide field for cotton raising, and a contemporary summarizes the steps now being taken, from which it appears that at Lagos a buying agency has been established, and there is said to be a plentiful supply of native labor. The natives, indeed, are understood to be keenly interested in the operations, and it is expected that some three or four thousand bales of useful cotton may be received in Liverpool this season. In Sierra Leone good hopes are entertained that an improvement of the indigenous cotton will give a very useful quality, and Sir Charles King-Harman says that it is "merely a matter of time and of encouragement to the natives for the export of cotton to become a substantial reality." On the Gold Coast the native methods are said to be primitive and difficulties of labor are yet to be surmounted, but samples have been approved, and there are prospects more or less favorable in Northern and South-

ern Nigeria, Gambia (to which an expert has just been despatched under the auspices of the Government and of the British Cotton-growing Association), East Africa, Rhodesia, and the Soudan. Any important development in the Soudan, however, must be contingent on the construction of the Suakim-Berber Railway, to the importance of which the Egyptian Government is fully alive. Other present or prospective cotton fields which may be mentioned are British Central Africa, from which good samples grown from Egyptian seed have been obtained, and which is said to wait for the completion of a railway from the Zambesi to Nyassaland in order to divert the abundant labor from less promising enterprise. Queensland has shown in the past that she can produce good cotton, the cultivation of which is now receiving special encouragement from Mr. Deakin, the Prime Minister. The West Indies seem to be capable of supplying a good Sea Island quality, as well as good staple Uplands, and have already put some excellent cotton on the Liverpool market; and in Ceylon trial is being given to patches of Tinnivelly, Egyptian, and American cotton with and without irrigation. Burmah, British Guiana, and British Honduras are other fields. All these are possibilities, and though nobody expects successful cotton-growing in every quarter of the globe, widespread experiment is naturally the first step in this great enterprise.

The question is of much interest to Canadian cotton manufacturers, not only in view of the contingencies of the American source of supply but because the special staples which would result from growing cotton in widely differing soils and in differing climates, would give greater diversity to the products of Canadian mills in the future. For both reasons, therefore, Canadian manufacturers should encourage a movement which will give them a greater variety of choice of raw material and under greater security of supply.

James Boyle, the United States Consul at Liverpool, in a recent report to his Government on the movement, says: "If the outside supply came in in sufficient quantities to make the English consumers virtually independent of the American supply, it is not unlikely that that event would mark the destruction of the present potentiality of the manipulator so far as the market is concerned. Speculation aside, the Liverpool broker naturally does not favor the new conditions and the disorganization which would probably at first characterize the trade when British-grown cotton became an appreciable influence in the local market." It is easy to understand the objections of those brokers who have the great speculative accounts that we have heard so much about lately. Their clients might transfer their operations to the stock market or the turf when the cotton market became

comparatively sedate, but a disorganization which would give more cotton to sell, from whatever part of the globe, does not seem to threaten any legitimate business. The suggested apathy or hostility of some sections of Liverpool towards the movement is also due in some measure, according to Mr. Boyle, to the shipowners, whose vessels now bring the cotton from the United States. A dwindling trade is always an embarrassment to shipowners, but if it comes to that no doubt some compensation may be found in the creation of fresh channels of enterprise. However this may be, "the movement goes on just the same. Those at the back of the movement are mostly master spinners, and they look at it as almost a question of life and death." So far as United States cotton manufacturing interests are concerned, they would not be jealous of the extension of the field of cotton growing. They are already large consumers of Egyptian and Indian cotton, and an increase in variety of staple will be of the same advantage to them as to British and foreign manufacturers. From a national and economic standpoint, the result of creating new areas of cotton cultivation would be to make the chief manufacturing nations mutually dependent on each other in the matter of supplies.

\* \* \*

#### IMPERIAL POSTAL POLICY.

At the annual meeting of the Canadian Press Association a paper by John A. Cooper, editor of the Canadian Magazine, on postal arrangements with the United States was the principal topic of discussion. At a time when our Government had to use United States railways to get mail matter into the Red River settlement and the North-West, an arrangement was made by which mail matter was exchanged between Canada and the United States at the domestic rate of postage of each country, and this arrangement has remained in force to the present day. Because of this free exchange the circulation of United States publications in Canada has increased in a remarkable way, while British publications which formerly sold largely in Canada, have remained stationary or actually declined, owing to the high rate of postage (8 cents per lb.), which they have to pay in coming to Canada. Recently Sir Wm. Mulock, to whom the association gives all credit, has reduced the postal rate to Great Britain, from offices of publication in Canada, to the same rate as publishers pay when sending to the States, but this low rate of half a cent a pound is not reciprocated by Great Britain.

The situation, therefore, is this, that United States publications have gained almost a monopoly of the Canadian market, compared with British or foreign papers, and the flood of United States papers in this country is largely of that class and quality

which should most be avoided for the moral health of our people. There are anywhere from 100 up to 1,000 United States papers circulating in Canada, against one Canadian paper circulating in the States, and consequently Canada is paying for the transportation over our railways of 100 times the weight of papers for which she gets a reciprocal benefit in United States territory. It is bad enough to have the minds of our young people poisoned by the sort of literature that forms the bulk of what comes in from across the border, but to ask the Canadian people to bonus the process of corruption is too much: Mr. Cooper's caustic comment is: "It is a wonder that the Universal Postal Union has not moved to commit Canada to the International Asylum for weakminded nations." He suggests a cancellation of the Canada-United States arrangement of 1875, thus putting the United States on the footing of any other foreign country which would pay postage of 5 cents per one-half oz. on letters, and 1 cent per two oz. on papers, whether from offices of publication or not. He estimates that it would make a difference of \$200,000 a year in the income of our postal service. The fact that the United States sells us \$80,000,000 worth of goods more than it buys from us he attributes largely to the trade introduced by United States publications, but by the step suggested: "Many United States manufacturers and publishers, who now post their Canadian mail in the United States would come to Canada to print their circulars, calendars, catalogues, weeklies and monthlies. It would be a boom to the Canadian Post-office, Canadian paper makers and workmen generally. Besides, it would help our national feeling. British and Canadian publications would meet fairer competition, and be considerably benefited. Our boys and girls would not be acquiring false notions about the importance of the United States. People would teach their children Canadianism by buying Canadian reading matter for them. There would be a renaissance in national literature."

Generally speaking, the freer trade is between two adjoining countries, the better, but unfortunately our United States neighbors have repeatedly raised duties on Canadian goods until they are on the average about twice as high as ours against them, so that our commercial relations all round are very much one-sided.

In the matter of postal relations with Great Britain, we have this peculiar anomaly that while Canada has given an advantage to British merchandise under our preferential tariff, and given the utmost encouragement to the circulation of Canadian publications in Britain; being in fact the pioneer of the Imperial penny postage, as well as of Imperial cheap newspaper postage, the Mother Country, a professedly free trade nation, taxes its publications out of the Canadian market by its prohibitive rate of 8 cents per lb.

Thus she helps to extinguish her own trade with Canada, for trade follows the press in these days.

\* \* \*

### THE RUSSO-JAPANESE WAR.

Hostilities have been commenced between Japan and Russia by the crippling of Russian warships by the Japanese, at Port Arthur and Chemulpo, and judging from the manner in which the plucky Japanese are handling their fleet, it would appear that, on sea at all events, the chances are in their favor. Regarding the effect of the war upon the textile trades, a prominent Japanese merchant informs us that it is anticipated the operations will be confined to the Russian and Corean coasts, and therefore the existing manufacturing industries will not be materially affected, although the fact that much money hitherto applied to the development of silk and cotton production by the Government, will now be required for war purposes, may have the effect of retarding industrial progress for a time. Japan is confident of being able to command the situation on water and hence should have no difficulty in protecting the mercantile marine. The fact, however, of the Japanese Government securing for transports, etc., all the available sea-going steamers, some seventy-five up to date, will for the present paralyze her export shipping trade. At present large quantities of silk and some \$20,000,000 worth of cotton is exported to China annually, and there will be no means of transporting this until vessels can be obtained to replace those now in the Government service. So far as Canada's trade is concerned, the C.P.R. steamers will still be available, and unless Russia succeeds in landing forces in Japan, which is improbable, commerce will not be seriously interfered with. One result of the war, our informant says, will be that the demand for Japanese goods will be greatly increased, by the advertisement which that country will obtain from the prominent position it has acquired in the affairs of nations.

Speaking of the relative military strength of the two nations, our informant states that while Russia has a larger army, the only means of transportation is a seventeen days' journey by rail, most of which is single track, and it would be impossible by this means to concentrate a force large enough to be effective. For this reason, if Japan retains supremacy on the sea, the war should be of short duration. At any rate Japan has been preparing for any emergency that may arise, and is confident of success. What the ultimate outcome of this war may be we cannot foresee. We can only express the hope that some means will be found whereby the contending nations may come to terms.

If China should be drawn into the fight, the war

would affect the cotton trade of Canada by curtailing, if not stopping altogether for a time, the shipment of Canadian cottons which now go to that country to the extent of several million yards a year.

\* \* \*

### THE TEXTILE SITUATION IN BRITAIN.

Writing of progress in loom manufacturing in Great Britain, a correspondent in the Yorkshire district refers to improvements now going on in looms for the weaving of high-class fancy goods. A firm of loom-makers, hitherto given over unreservedly to the supply of cheap, fast Bradford looms, are seeking now to wrest the honors from those who made a study of the slower and more cumbersome machines for heavier and finer fabrics. "The new loom," writes our correspondent, "is still on its trial though from the fact that a leading Huddersfield firm has ordered a battery of twenty-five, it may be seen that its reception is so far favorable. Nothing daring in the way of innovation appears. By assimilating the good points of the three best makes, and increasing the speed to 100 picks a minute, the new appliance bids for success. The best work, and Huddersfield cloths need to be flawless, has never been done at the same pace. Cloth buyers are aware of the material difference that exists between Huddersfield and Bradford methods. The one relies upon a large profit and a small turn-over; the other upon the converse. Huddersfield treats its goods with loving care and treats a damage to a piece as a mortal sin, while Bradford goes slap-dash and pays little heed to trifles, accidents or mistakes. Automatic looms are still regarded with suspicion and those that are installed, if rumor may be credited, are in mills financed by makers of those appliances. The English makes invariably depend upon the change of the shuttle in lieu of the bobbin. One at least aims at the automatic weaving of worsteds and woolens of the heavier sort, but all of its imperfections are not yet overcome. A broken pick is obviously a more serious matter in a suiting at a dollar and a half the yard than in a calico at five cents. Looms in the cotton trade can scarcely be said to be working at all. Fifteen thousand are standing idle in Burnley, as I write, and thousands of Lancashire looms are working no more than forty hours per week. Spinners are losing so heavily that many have foregone the usual stock-taking. Since dividends are out of the question, they are disposed to see what another quarter will do to mitigate their grievous loss. Cotton comes forward very slowly, and spinners are arguing with, rather than buying, from brokers. The cotton disaster, if it has done nothing else, has stimulated the effort to grow cotton on British soil as nothing but a calamity could have done. East and West Africa and the West Indies are to be encouraged to the utmost, and though

cotton-growers in the States sneer at the schemes of our associations, their work will go persistently along. In the textile trades here it is fully understood—the words of visiting Canadian manufacturers seem to put the point beyond question—that the Canadian intention is to raise the duties upon imported fabrics. The intention is philosophically accepted. Woolen men agree that Canada has the right, if she fancies it to be her interest, to bar out British cloths or make them dear to her own people. To be barred out of markets is no new experience, although a 40 per cent. tariff is not sufficient to exclude a considerable import into the States, for instance. Before the year closes, our account with Uncle Sam for woolens and worsteds will be a rough two millions sterling, say ten million dollars. English manufacturers are hard to beat. Outside any politics, the typical woolen man of England finds it hard to understand why he should be asked to give a preference upon corn, and his naval and military contribution to a Dominion that frankly announces its desire to exclude the goods he makes. Under the pressure of rival politicians, he is looking about for a reason without getting at all near to finding it. The proposition may be open to other constructions, perhaps much more can be said of it, but in faithfully reporting the attitude of the man with a mill, no harm should be done to either party. Looking at the matter as an ice-cold bit of business, neither the woolen master nor his operatives see the fairness of the transaction."

\* \* \*

—The importation of woolen goods into Canada has nearly doubled in the last seven years, or to be precise, the imports of woolen goods in 1897 were \$7,177,954, while in 1903 they had grown to \$13,612,942. If this increased consumption had been taken up by Canadian mills, we should have had many new mills started, and the capacity of many existing mills doubled or trebled in this week of years. The wages bill required to produce this extra cloth would amount by the present year to \$7,000,000—a good round sum to be circulated among Canadian merchants, agriculturists, and others, as the result of the increase in home trade, brought about by the development of the Canadian woolen industry. Even if half this importation could have been handled by Canadian mills, it would be no small thing for Canadian trade.

\* \* \*

The Rapid City Power, Light and Woolen Manufacturing Company, Manitoba, has commenced the construction of an electric line from the power house to the mill.

The city of Hamilton, Ont., have paid \$300 to owners of boats, as compensation for damage caused by the Canada Colored Cotton Co. turning its hot water into the bay, under the city's directions. The water has now been diverted to the sewage works.



## Among the Mills

Co-operation is one of the guiding principles of industry today. It applies to newspapers as to everything else. Take a short in "The Canadian Journal of Fabrics" by contributing occasionally such items as may come to your knowledge, and receive as dividend an improved paper.

Schrum & Letson, shoddy manufacturers, Salem, Ont., have sold their business.

The Boston Cordage and Twine Co. will establish a factory in St. John's, Newfoundland.

A. B. Connor, manager of the Alvinston Flax Co., has started a basket factory in Alvinston, Ont.

The Merchants' Rubber Company, at Berlin, Ont., commenced operations in their mill room on January 21st. The machinery is working satisfactorily.

The General Artificial Silk Company, an American concern, have rented part of the Wagner factory, Toronto Junction, Ont., and intend to start work immediately.

The Dominion immigration agent at Edmonton, N.W.T., has received enquiries from Oregon regarding a site for the erection of flax mills in the town.

The machinery and works in the new additional part of the felt shoe factory, at Galt, Ont., is nearing completion. The manager has just returned from his western trip, with better prospects and larger orders than any previous year.

E. J. H. Pauley, president of the Linen Mills Company, has completed arrangements with the Orillia, Ont., town council for a five acre factory site. The company begins building operations when spring opens. Owing to similarity in name to another company establishing a factory in Bracebridge, the name has been changed from the Dominion Linen Mills, to the Canada Linen Works, Limited. Mr. Pauley's father is in the Old Country buying machinery, and securing operatives.

On January 11th, 120 weavers in the Paton mills, Sherbrooke, Que., struck owing, it is alleged, to the boss weaver fining them unnecessarily high for spoiled work. They returned to work on January 21st, as a result of the efforts of Felix Marois, of Quebec, Government representative. The complaints will be taken up by the management and given fair and careful consideration. The whole mill was closed down January 16th, throwing 700 hands idle, with a daily loss of \$1,000 in wages. During the strike the management received many offers of assistance from other mills, and if the strikers had held out, their places would no doubt have been filled. The Paton mills, which, owing to the low water in the Magog river, have for some months been able to operate their works only a portion of each day, have started to run full time again.

The Court of Appeal recently gave judgment in the case of Thomas H. Traplin, of Hespeler, against the Canada Woolen Mills, to recover damages for injuries sustained owing to the fall of an elevator. The case was tried at Milton last April, and the jury found in effect that the elevator was in a dilapidated condition, and although it was for lifting goods, the defendants had permitted their workmen to use it, and the plaintiff had used it. The jury awarded the plaintiff \$3,150, and the defendants appealed to the Court of Appeal, which has unanimously confirmed the jury's verdict, and dismissed the appeal with costs. Under the Workmen's Compensation Act, the limit for damages which workmen may recover for injuries is \$1,500. The plaintiff successfully contended in this case that he was entitled to damages at common law, in which case there is no limit, and the court and jury have so found.

David Hart, boss finisher in the Hewson Woolen Mills, Amherst, N.S., has resigned.

The National Woolen Mills, Streetsville, Ont., are installing another set of cards.

The John Dick Co., Limited, Seaforth, Ont., are installing additional machinery.

The Ontario Felt Company's new mill, Dundas, Ont., is now running. A. M. Morrison is general manager.

The Maple Leaf Woolen Mills Co., Markham, Ont., have built a new dye house, and installed additional machinery.

Samuel Brown, formerly of Waterloo, Ont., is overseer of carding in the Auburn Woolen Mills, Streetsville, Ont.

The Elmira Felt Co., Elmira, Ont., are about to install additional machinery, which is now on its way from England.

The Marysville cotton mill, Marysville, N.B., had to close down for a few days recently on account of the scarcity of raw cotton.

The Guelph Worsted Spinning Company, Guelph, Ont., are installing a new set of cards and mules for carpet and hosiery yarns.

The M. B. Perine & Co., twine mills, Doon, Ont., were closed down recently, for want of coal, owing to snow-blocks on the railway.

G. Reid & Co., Toronto, are installing new machinery for cleaning up waste fibres in the flax mill of the Essex Flax Mills Company, Essex, Ont.

The International Flax Fibre Company has moved into head offices at St. Joseph, Ont., and is establishing there a factory for the treatment of flax and linen.

The report that the Cornwall and York cotton mills, St. John, N.B., would have to close down, owing to a shortage of cotton, has been officially denied.

It is reported that the Hoffman-Corr Manufacturing Co., recently taken over by the Universal Thread Co., Fitchburg, Mass., will erect a cotton batting mill at Toronto, Ont.

Wm. Smith, on leaving the Rosamond Woolen Co., Almonte, Ont., to take up the position of manager of the Enterprise Hosiery and Underwear Co., Toronto Junction, was presented with an address and a gold watch by the employees.

The Empire Carpet Company, of Dundas, Ont., has had a brief existence, being already in the hands of its creditors. A trustee and three inspectors have been appointed, and the factory is advertised for sale in this issue. An effort will be made to secure new capital and reorganize the concern on a substantial basis.

The Oxford Woolen Mills, of Oxford, Nova Scotia, have just completed their new brick and stone mill and have their machinery installed therein. The mill is one of the best equipped in Canada. The manufacturing department is now being conducted by W. G. Thomson, who is occupying the position of superintendent and designer. He comes to the company from Leeds, England, and was engaged in manufacturing there for many years.

The Guelph Carpet Mills Company recently installed a tapestry and velvet carpet plant, and are now the only mills in the Dominion turning out tapestry, velvet and Brussels carpets. This department necessitated extensive additions to their buildings, and they recently erected two stone structures. One of these, 50 by 175, and three stories high, is used as office and stock-room, while an addition of 50 by 125 feet was made to the loom-shed, making that structure of a total area of 50 by 250. The officers of the company are as follows: President, Christopher Kloefer, manager, secretary, and treasurer, Robert Dodds.



The low water in the rivers of Eastern Ontario is becoming a serious question to the woolen mill owners of Almonte, Carleton Place, and other towns, as it has been for those of Sherbrooke. A special meeting of manufacturers was held a few days ago at Almonte. Among those present were: James Gillies, representing the Gillies' interests, and M. Brown, from H. Brown & Sons, Carleton Place; B. Rosamond, M.P., from the Rosamond Woolen Co.; J. M. Rosamond, from the Almonte Knitting Co.; James W. Wylie, representing the Wylie Mills; A. Young, of Young Bros.; R. Lee, of Lee & Taylor; James Robertson, representing the corporation of Almonte, and Mayor Thoburn, who presided. J. M. Rosamond was appointed secretary. The meeting discussed the possibility of securing a more uniform water supply for power purposes by mill owners along the Mississippi. All agreed as to the necessity of some action being taken, and a suggestion from Mr. Gillies looking to the formation of a joint stock company for the purpose was unanimously adopted. The object of the company is to secure possession of certain lakes on the upper Mississippi, to renew and keep up the dams so as to store up water in the spring to be used when required to keep the river up to a working level. A committee, consisting of James Gillies, B. Brown, B. Rosamond, F. B. Caldwell, and Mayor Thoburn, was appointed to draw up a petition to the Government for a charter to form a company and to secure the signatures of the various mill-owners. Three concrete dams will be required.

\*\*\*

### Fabric Items

The Newfoundland Clothing Co. are erecting a new factory at St. John's.

The J. Stevens Arms and Tool Co., Chicopee Falls, Mass., have devised an ingenious puzzle which they will send to anyone on receipt of two 2-cent stamps, Canadian or U.S.

The Manchester Chamber of Commerce will make representations to the Canadian Government to have the duty on carpet samples refunded when they are returned to the makers in England.

Wesley Allan, proprietor of the clothing factory at Newmarket, Ont., is now installed in a new brick building in which forty hands are employed on men's clothing. M. Allan manufactures for W. R. Johnston & Co., Toronto.

At the annual meeting of the Wholesale Dry Goods Association of the Montreal Board of Trade, the following officers for the ensuing year were elected: President, George B. Fraser; first vice-president, A. Scott Robertson; treasurer, Robert Henderson; directors, K. A. Brock, R. W. Macdougall, Alphonse Racine, and R. N. Smythe.

A fire in Montreal on January 19th destroyed the stocks and warehouses of the following firms: Swift, Copland & Co., wholesale hats and caps; damages, \$50,000. Finley, Smith & Co., wholesale wooleens and tailors' trimmings; loss, \$7,500. Woodhouse, Rozand & Co., wholesale millinery, loss, \$4,000. The King Clothing Co., manufacturers of clothing. The losses were covered by insurance.

A C.P.R. silk special of fourteen cars from the Pacific coast last month carried a cargo of Japanese silk, valued at \$2,500,000. The bulk of the consignment was to Prescott, N.Y., and the train had clear right of way making Imperial limited time from coast to coast. Another consignment of silk goods and raw silk is due this month by the "Empress of China," measuring 960 tons, valued at \$1,800,000, which will require twenty cars to transport it to the silk mills, at Weehawken, N.J.

### CENTRIFUGAL DYEING MACHINE.

A. Klipstein & Co., 122 Pearl St., New York, have placed on the market a new centrifugal dyeing machine, the advantages of which are described as follows:

Until the advent of the centrifugal principle in cop dyeing, the attempts to dye yarns in compact form, particularly in cop and cheese have been almost unqualified failures—the results in most cases being failure to penetrate, damage to the noses, and bottoms, and consequently great loss in use—and in those few cases where good dyeing has been accomplished, it has been at great expenditure of labor, time

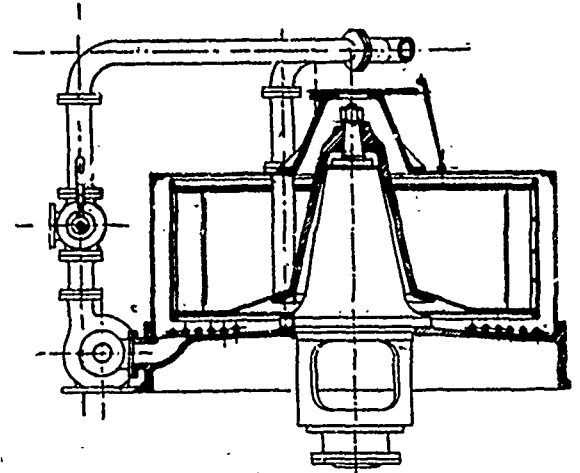

and handling, which has equalled if not exceeded the cost of dyeing in the skein. Processes requiring skewering, with costly perforated metal tubes on which there is a great and constant depreciation, and which almost invariably damages the cops by stabbing-processes in which the packing of the cops has to be carefully padded with sand or other loose material, in order to press it into a homogeneous mass, and which entail laborious and costly washing off and drying, and which further depend upon the efficiency of pressure and vacuum, are all very well for the chemists' laboratory, but are not the thing for the manufacturer who makes his profits by quantities.

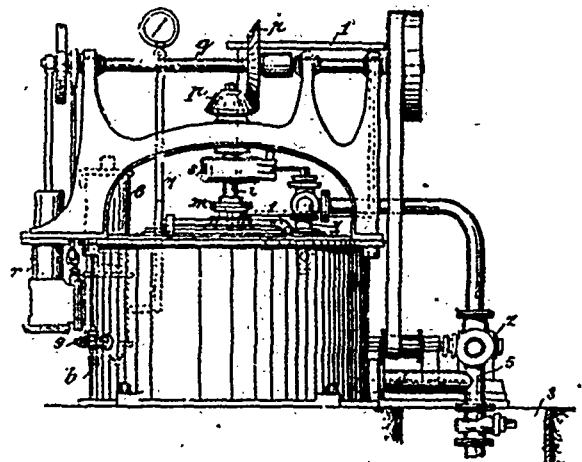

The distinctive feature of this machine is that it is special-ized to save processes in the manipulation of dyed yarns. The ordinary system requires that the yarn shall be wound from cops into skein in order to dye. From the skein after dyeing it has to be rewound into cone, spool or other form

before it can be used. Yarn in this machine is dyed directly in the cop as stripped from the mule spindle, and can be used without any of these processes. Ring yarns, instead of being skeined, may be wound direct on the cone, at the same cost as skeining and dyed in this state, saving the rewinding and attendant waste. To use yarn dyed direct in the cop will show a saving in processes alone of 5 cents per lb and upward according to counts. The capacity of a 72-inch machine in sulphur black may be taken at 1,000 lbs. per day at least. A week's output, say 6,000 lbs., at 5 cents saving in processes alone, means \$300 a week. A saving in labor and steam would represent another \$20 to \$30 per week on this production. The machine dyes all the direct colors, as well as the new fast sulphur blacks, and, as there is already a large range of these dyes, and almost daily increases to them, the utility and efficiency of this machine is unequalled by any other in existence.

The machine is built on the principle of the "Hydro Extractor" covered in, and has a partitioned cage, which receives perforated boxes packed with cops or other materials. Dye or other liquor is introduced by a spray, supplied by a pump, forcing the liquor against the boxes of cops which are fitted around the revolving cage, by which means the liquor is centrifugally thrown through the material and penetrates with uniformity and certainty. A steam coil under the pan keeps the liquor at boiling or any desired temperature, and the pump being connected to a threeway tap, either circulates the liquor, returns it to the cistern, or, in extracting, sends it down the drain, thus the liquor may be used again and again with little diminution in bulk, and all the advantages of a standing bath. The time required for dyeing varies, of course, with the dye to be obtained. In some cases, as for instance with direct colors, thirty minutes in boiling liquor is sufficient; the maximum for the more difficult colors is about one hour; and under all circumstances much less than in the open vat. After dyeing and without any further disturbances, the material may be washed, softened and "whizzed" comparatively dry, thus saving labor, and much time in stoving. Where the yarn can be wound or used immediately, stoving may be entirely dispensed with. There is no damage to the shape, or fibre of the yarn or other material; cops dyed by this process shutting as easily as in the grey; tubes being quite unnecessary. The saving in tubes, perforated spindles, and time skewering, alone (as required in other cop dyeing processes), makes a difference of at least 3/8 per lb. saving in favor of our machine, and the labor and steam cost is exceptionally small. In addition to dyeing, the machine is built to suit other special work, and may be of either the horizontal or vertical types under-driven or over-driven, and by either engine, strap, or electric motor. The sizes vary from a capacity of 60/80 lbs. of cops for the No. 1 machine, 100/120 lbs. for the Nos. 2 and 3, and 240/260 lbs. for the No. 4 machine, at each filling. The machine is self-contained. It is driven by an attached engine, has a direct driven pump and special automatic lubricating device; is furnished with two sets of cop boxes; in fact is ready for attachment to the purchaser's steam, water and liquor connections. It is sold, f.o.b., New York, Boston, Philadelphia, or Montreal, packing free. The Montreal office of A. Klipstein & Co. is 17 Lemoine street.

W. H. Boyle, superintendent of the Boyd, Caldwell & Co.'s woolen mills, Appleton, Ont., was presented by the employees with a handsome easy chair, on the occasion of his marriage on January 22nd.

BRITISH WOOLEN EXPORTS.

Returns recently published show that the total value of woolen and worsted manufactures exported from Great Britain in 1903 was £15,864,254, as compared with £15,261,359 for the year 1902. This total includes carpets, flannels, blankets, damasks, hosiery, smallwares, etc., and the following figures show total quantities of woolens, worsteds, and carpets exported during these years:

WOOLEN TISSUES.		
	1902. Yards.	1903. Yards.
<b>Heavy Woolens--</b>		
Broad, all-wool .....	10,132,500	10,512,000
Broad, mixed with other materials..	13,453,600	13,772,600
Narrow, all-wool .....	384,400	375,400
Do., mixed with other materials....	630,800	600,500
<b>Light Woolens--</b>		
Broad, all-wool .....	6,204,400	5,830,300
Broad, mixed with other materials..	9,603,000	10,504,400
Narrow, all-wool .....	2,346,600	3,082,200
Do. mixed with other materials .....	4,384,400	5,979,400
<b>Total .....</b>	<b>47,139,700</b>	<b>50,747,800</b>
<b>WORSTED TISSUES.</b>		
<b>Coatings--</b>		
Broad, all-wool .....	9,527,100	9,026,200
Broad, mixed with other materials ...	6,334,900	6,898,200
Narrow, all-wool .....	555,300	480,800
Do., mixed with other materials ....	1,075,500	777,300
Stuffs, all-wool .....	11,082,500	12,132,400
Stuffs, mixed with other materials ..	74,040,700	77,114,500
<b>Total .....</b>	<b>102,616,000</b>	<b>106,429,400</b>

**CARPETS.**  
All kinds, not including rugs ..... 7,672,100 8,595,100  
The quantities of woolens, worsteds, and carpets exported to Canada are given below, and it will be seen that in each class there was a marked increase in 1903: The following figures show the increases for Canada.

	1903; Yards.	1902, Yards.
Worsteds .....	12,175,200	10,726,100
Carpets .....	3,218,600	2,480,900
Woolens .....	5,225,300	4,929,500

NEW COMPANIES.

The Canada Wool Stock Co., Limited, Toronto. Capital, \$20,000. To manufacture and deal in woolen and cotton waste, shoddy and wool stock; woolen, cotton and felted goods and blankets, etc. H. J. Le Fevre, Louise B. Le Fevre, Lakefield, Ont.; H. C. Gwyn, Dundas, Ont.; J. M. Ewing, and B. Osier, of Toronto.

The Clark Blanket Co., Limited, Bullock's Corners, Ont. Capital, \$40,000. To manufacture and deal in blankets, and woolen and cotton goods, or goods made of a combination of wool, cotton, or shoddy. J. Alex. Clark, F. P. Thornton, J. Allen Clark, Agnes Thornton, and Sarah J. Clark, of West Flamboro, Ont.

McIntyre, Son & Co., Limited, Montreal. Cap. 1, \$1,250,000. To purchase the business of McIntyre, Son & Co., Montreal, and to carry on the business of manufacturing, spinning, weaving, dyeing, bleaching, printing, buying, selling,

dealing in cottons, yarns, cloths, prints and other manufactures of cottons and other textile fabrics; to purchase and sell all kinds of hosiery, underwear, fancy wool, cotton and knitted goods; and to purchase, erect, construct, and operate mills, factories, buildings, warehouses, machinery and plant, for the purposes of the said business, etc.

The William A. Greene Co., Limited, Waterloo, Ont.; Capital, \$50,000. To manufacture any textile fabric into shirts, collars, cuffs, and all other articles of a like nature. W. A. Greene and F. S. Kumpf, C. Kumpf, J. Uffelmann, A. L. Kumpf, of Waterloo, Ont.

Hodgson, Sumner & Co., Limited, Montreal. Capital, \$1,000,000. To purchase the business of Hodgson, Sumner & Co., and carry on a general dry goods and manufacturing business; and to erect buildings and machinery in connection therewith. Jonathan Hodgson, G. Sumner, T. E. Hodgson, J. Gardner, W. C. Hodgson, and F. Sumner, of Montreal.

The Smith Manufacturing Co., Limited, Toronto. Capital, \$40,000. To acquire the Smith Wool Stock Co., and to carry on the business of manufacturers and dealers in wool stock and cotton, and to carry, on the business of custom and other dyeing. Mary T. Smith, George Smith, G. Herbert Smith, A. Busns, H. S. Harwood, A. Nelson Burns, and J. A. Burns, of Toronto.

The Ontario Government have issued licenses to the following companies:

The Canada Linen Works, Limited, a Nova Scotia corporation, "to carry on the business of preparing, carding, spinning, weaving, and working flax, wool, cotton, jute, ramie, hemp, tow, or other fibres necessary for the purpose of textile manufacture, etc." Capital, \$500,000. Edwin J. H. Pauley, Toronto, president of the company, is appointed attorney.

The Double Use Mitten Co., an Illinois, U.S.A., corporation. "To manufacture all kinds of gloves and mittens." Capital, \$75,000. H. G. Smith, Dundas, Ont., glove manufacturer, is appointed attorney.



**BRITISH TEXTILE TRADE WITH CANADA.**

The following are the sterling values of the exports from Great Britain to Canada for December, and the years 1902 and 1903:

	Month of December,		The Year,	
	1902.	1903.	1902.	1903.
	£	£	£	£
Wool .....	6,617	8,930	37,631	55,367
Woolen tissues .....	39,192	41,075	537,865	560,962
Cotton piece-goods .....	85,806	98,533	802,892	819,726
Worsted tissues .....	107,945	108,506	814,351	921,297
Carpets .....	15,064	18,957	235,732	310,357
Haberdashery .....	15,774	22,806	219,464	355,875
Jute piece-goods .....	18,989	20,717	183,397	220,616
Linen piece-goods .....	21,857	23,830	194,147	195,388
Silk, lace .....	900	1,029	3,779	8,682
Silk, articles partly of...	7,571	2,722	74,013	64,265
Apparel and slops (ready-made clothing) .....	20,214	20,178	308,923	361,112



Henry Pullen, one of the best known wool buyers in Canada, died recently in the Toronto General Hospital from erysipelas. Deceased, who was about 54 years of age, was born at Brighton, England, and came to Toronto twenty

years ago, where he established a wool business on Markham street. He leaves a widow, but no children.

A boiler explosion at Harriston's flour mill, Parkhill, Ont., on February 10th, badly wrecked the woolen mill of N. Matheson, adjoining. This mill runs one set of cards, two looms, and 200 spindles, operated by steam power.



**THE WAR AND THE SILK AND COTTON MARKET.**

A despatch from New York states that war in the Far East already has affected the silk piece goods market of the United States. The majority of prominent importing houses have just announced advances of 10 per cent. on Habutai and other silk fabrics manufactured in Japan. The effect on the cotton trade has not yet been noted to any marked extent. There are enquiries from Japan for large amounts of heavy cotton, but the high prices for goods for the use of this product will cause a curtailment of orders from this source. There is little hope for a cessation of hostilities this year, and indeed a long war is predicted. The trade in American cotton with China and Japan indirectly amounts to the products of about 600,000 bales.



**DRY GOODS SECTION TORONTO BOARD OF TRADE.**

There was a good attendance at the annual meeting of the wholesale dry goods section of the Toronto Board of Trade held last month. Trade was reported good during the past year. Reference was made to the benefits accruing to the trade by the postponement from June to December of the imposition of the German surtax. Had the surtax gone into force in June, the trade would have had to pay largely increased duties on quantities of goods ordered and in transit.

The following officers were elected: Chairman, J. W. Woods; deputy chairman; H. J. Caulfield; secretary-treasurer, F. G. Morley; executive, J. D. Allan, R. W. Spence, John Muldrew, E. J. Dignam, W. R. Johnston, J. M. Alexander, John Macdonald, W. R. Smallpiece, A. F. Rodger, A. T. Reid, J. D. Ivey, Andrew Darling, Toronto; J. W. Little, London; John Knox, Hamilton.



**WESTINGHOUSE TURBINES IN A TEXTILE MILL.**

The Westinghouse Machine Company have recently received an order from Joseph Benn & Sons for a turbo-generator set to be used in furnishing light and power for driving machinery in their new alpaca mills, which are to be built at Olneyville, R.I. This factory will be an American branch to their Yorkshire, England, mills. The turbine is of the Westinghouse-Parsons type, of 400 kilowatts' capacity, and is to operate under a steam pressure of about 150 pounds. Superheated steam will probably be used. The turbine will drive a 400-kilowatt three-phase Westinghouse alternator, which will deliver power to the motors situated in the various parts of the mill for the purpose of driving machinery in the different departments. A 7½ by 7 Westinghouse standard engine-type outfit is also being supplied and will be direct connected to the generator rig for furnishing the exciter current. F. P. Sheldon & Company, mill engineers, of Providence, are now at work designing the plans for these mills.

### LAST YEAR'S BRITISH TEXTILES.

From a comprehensive review of the British textile trades, in 1903, in the Manchester Guardian, the following extracts are taken:

#### COTTON INDUSTRY.

The year 1903 will long be remembered by cotton spinners and manufacturers, and by the whole of the textile allied trades, as one brimful of exciting vicissitudes and perplexing situations, and a close-of-the-year survey of the situation shows that operations of the mills in Oldham and district have been most unsatisfactory. The general outlook at the beginning of the year was anything but hopeful, the machinations of the American and Liverpool speculators manifesting themselves at the opening month of the year when the market became unsettled, and a tendency to higher prices culminated in talk of short time. Much interest was also evinced in the movement of the British Cotton Growing Association to widen the area of cultivation in British colonies and dependencies and ultimately alleviate the lot of the suffering millowners of Lancashire by making them independent of America for their supplies. In dealing with the annual returns of the past year's operations of the Oldham and district cotton concerns, and taking as a basis the official list of the Lancashire Share Brokers' Association, it is seen that the number of companies issuing balance-sheets was 70. One of these has not had a full working year and may therefore be left out of the reckoning. The losses of 49 of these companies amounted to £90,748, while the aggregate profits of the other 20 companies were £37,822, leaving a net loss of £52,926, or about £770 per company, whereas the average loss per company last year was £16. The paid-up share capital of 69 companies is £2,921,321, which with loans, debentures, and mortgages totalling £1,549,433, gives a working capital of £4,470,754, so that the net loss is equal to a percentage of 1 1-3. Forty-five companies have declared dividends averaging just under 4 1-3 per cent. The debit balances of thirty-five companies are £103,754, and the credit balances of thirty-four companies £98,074, there accordingly being a net debit balance for sixty-nine companies of £5,680, or £82 per company. So serious has been the depression in the cotton trade of Blackburn this year that no parallel can be found to it except in the early sixties, when the cotton famine in America spread dismay, ruin and starvation throughout Lancashire. Since that terrible time the staple industry of Blackburn has experienced many prosperous years, alternate, it is true, by some lean, if not altogether unprofitable ones, but for some time now the repeated tendency has been in the direction of fairly long periods of more or less serious stagnation. The year opened with a rather gloomy prospect, for though cotton was not abnormally dear the demand for the product of the looms was slight, and then only at prices which could scarcely be considered remunerative. When it is borne in mind that perhaps 75 per cent. of the cotton cloths of Blackburn are exported to India it will be seen that a devastating famine in that dependency of Great Britain is bound to have a serious effect on the weaving trade of the town. And though three years have passed since India had a serious visitation of that kind, the demand for cotton cloths has not been commensurate with the recovery. Still the great bulk of the looms of Blackburn were kept going at the beginning of this year, and about March the outlook was not unpromising. Few weavers were idle, and taken altogether the state of the trade was considerably better than at the corresponding time of the previous year. Manufacturers and operatives as well, thought that the dark cloud of depression

which had hung over them so long was about to pass away, at least for a season. The anticipation of better times was short-lived however. Within the next two months hundreds of looms had stopped, and as a consequence many weavers were forced into idleness, whilst others often found themselves "playing" for beams several days in each week. Things continued to go worse, for such was the success attending the manipulation of the "corners" in America that cotton could not be obtained except at impossible prices. By the middle of the year short time was pretty general in the town, and continued to grow until a modest estimate placed the number of looms standing idle at some 20,000, which meant that the amount paid in wages weekly had been decreased between £5,000 and £6,000. The distress among the operatives ere this became acute, and their trade organizations, by special grants and in other ways, expended almost £12,000 in relief of it. The only hope for improvement was the coming of the new cotton crop, but this was yet a long way off, and in the meantime the Mayor found it necessary to open a relief fund. It was some time after the new crop began to arrive before many of the idle looms were set running, and even now there are 2,500 stopped, in addition to a few which are waiting for warps. And the outlook is far from promising, for experts are of opinion that the American cotton crop will not be sufficiently large to meet all demands. So far as can be gathered, notwithstanding the deplorable depression, there have been very few failures in the trade, though it has from time to time been rumoured that several firms would have been forced to go under had it not been that financial assistance came to them just in the nick of time. But there are several manufacturers who are not yet out of the wood, for having anticipated that the arrival of the new crop would bring down the price of cotton, they booked orders for December and January delivery at a figure which at the prices now ruling for the staple, will land them in serious loss. The trade in Burnley, Bolton and Preston is spoken of in the same strain by the Guardian correspondent.

While for centuries the staple trade of Rochdale has been the manufacture of flannel, the cotton industry, which was introduced about 113 years ago, has outgrown it, and now affords employment to by far the greater number of the inhabitants. There are in Rochdale and its villages 50 spinning mills and 18,000 looms, and the machinery is employed almost exclusively on American cotton. Consequently when the recent shortage of cotton took place all the mills, with the exception of three, were reduced to working short time. The operatives suffered severely, but not so seriously as those employed in other towns, as the majority of the workers in Rochdale are members of trade unions. The card-room operatives, for instance, who were thrown out of employment, were paid no less a sum than £1,400 by their association, and the Weavers' Association distributed to their unemployed members £1,200, irrespective of the sum that the Spinners' Union paid to their own members to assist them to tide over the time they were out of work. The operatives who suffered most, were those who were not members of any trade union. If it had not been for the existence of these organizations, there would have been much more serious distress in Rochdale and its district. The result has been that the increase in the outdoor relief granted by the Rochdale Guardians has not been much more than 5 per cent. in excess of the previous year. But few cotton operatives of the respectable class applied to the guardians for relief. The men who were chiefly relieved were those whose wives' and children's earnings had ceased. For the last three years fewer looms have been employed, and during the last year 2,000 have ceased running. Capitalists, as

well as operatives, have sustained severe losses through the shortage of cotton. The balance-sheets of many first-class firms show that dividends were not paid, except by a few who drew on their reserve funds. Those firms that had stocks of calico which was made when cotton was at its normal price, have benefited by the late reduction of production, for they have considerably reduced, if not entirely cleared out, their old stocks, the accumulation of years. Rochdale, so far as spinning mills are concerned, compares favorably with other towns. For years new mills have been built on the most modern plans, and fitted with the best of machinery, and now these concerns are keen competitors with those of Oldham. Nearly all the mills are now working full time, and it was hoped that a satisfactory trade would be the result when the new crop came in, but these anticipations have not been realized in consequence of speculators interfering with the legitimate cotton market, and some of the firms are considering the advisability of again resorting to short time.

#### BRADFORD.

On the whole, it cannot be said that the Bradford trade during 1903 has had a bad year. It is almost an axiom that higher prices mean better business, and certainly during the twelve months there has been an appreciation in the values of all raw materials. The continued shortage in merinos has thrown the demand on to lower classes of colonial wool, and from these on to some classes of English wool. Even merinos have touched a higher figure than has been noted since 1900, and the same remark applies to 40's crossbred. A standard homegrown article like Lincoln hogs has since the spring touched 8d., and a little more, which is nearly the price of 1900. There have naturally been some pronounced fluctuations in value, and considerable tension between topmakers and spinners has resulted, but it is significant that the year has passed without a single commercial failure in the Bradford trade of any note. The output of the trade, as a whole, especially with regard to the products of long wool, has certainly not been quite maintained. While the demand for ladies' indoor wear has not been largely affected by the weather, there has been a sensible falling off in their requirements for outdoor wear, especially during the summer. The ladies seem to have considered that almost anything would do "for such a climate." On similar grounds, there has been an appreciable diminution in the consumption of men's wear for the home market, though Canada and other markets, except the United States, have taken fair quantities of worsted coatings. Merino wool, notwithstanding the attention which the producing branches have paid to lower classes, has firmly maintained its value. Topmakers seem to have kept their heads, and not to have sold beyond what the short supply would warrant. The attention paid to low and medium crossbreds naturally resulted in an advance of rates, but it must be admitted that a large portion of the advance, which took place during the autumn in Bradford, must have been to some extent artificial. The fact, however, remains that 40's crossbred tops have at one time risen to a point nearly double the lowest value of 1902, and quite double the value of the lowest point reached in 1901. One aspect of the year's proceedings which must not be lost sight of is that Buenos Ayres and Monte Video wools are coming more and more into favor as substitutes for merino when it becomes too dear, and also very largely for special purposes, and a considerable quantity of B.A. tops are actually being imported into Bradford from the Continent, where they are turning them out in better condition than the combers of Bradford and the district. At the same time, Bradford seems to be quite alive to the situation in this re-

spect, for an unprecedented number of buyers went out from Bradford this year for the current wool season in Buenos Ayres. For growers of, and dealers in, British wools, the year should have been a good one. It is true that the wools which chiefly compete with long sorts of colonial have not risen in value to the extent that their imported competitors have. Nevertheless, Lincoln hogs have for some time been on a level just above or below 8d., while wethers have been worth about as much, whereas the latter during 1902 more than once touched a figure as low as 43d.

#### LEEDS AND DISTRICT.

The general expectations of a good year have not been fulfilled, and yet for the first six months there was a moderately good trade. The last few months have been the worst of the year, and for many years, and there is an unusually large quantity of machinery idle, and generally the year has been a very poor one as to the amount of business done, and a very bad one as regards profits. The chief cause has been the unsatisfactory weather, which has lasted practically from the beginning to the end of the year. Then there has been the slackness in the iron and kindred trades, and at the present moment there is the fiscal upset. These adverse factors are operating against trade, so that the outlook is considered anything but promising and a long spell of dullness is expected. The profits have been seriously interfered with by the advance and continued firmness in wool as regards high-class goods, and the dearness of cotton used in the manufacture of low goods, especially cotton warps. There has only been an indifferent demand for woollens at any time during the year, but in the last few months it has fallen off considerably, the home trade being especially depressed. The South African market has lately been taking very little, the large quantity of goods rushed over there immediately after the war has not yet been disposed of. Australia has been taking less than usual, but there are now signs of improvement. Canada, however, is an exception, and has been a fairly good market. The demand for plain goods in blacks and blues has been small, and the fashion is now on fancy tweeds, chiefly in an endless variety of stripe patterns in all shades of grey. Covert coatings, too, have sold fairly well, but the old style of covert seems to be worked out except in the high-class trade; but in whatever style they are made, and there are a great many, grey is the chief color, which is more suitable to the weather we have had than light shades. Prices all round have been extremely difficult to obtain at all adequate to the price of raw material. In worsteds, plain blacks and blues have been exceedingly quiet throughout the year, and apart from price do not seem in favor. Fancy worsteds have been in rather better demand. The year opened well, but repeat orders were very small, indeed, consequently merchants are buying very little for next spring. Winter orders also have been small. The production of these goods has fallen off considerably, which is now much less than formerly. Prices have been firmer and an advance has been obtainable as many of them are made of pure wool only. Canada has now become a good market for Morley goods, yet in the face of a busy year, with raw material dearer (especially cotton), no higher prices are obtainable for goods. A cheerful state of things prevails also in the Yeadon and Guiseley district, and during the whole year employment has been good and long hours have been run in several of the mills, which have been engaged chiefly in the production of fancy tweeds suitable for ladies' wear, in costumes, dress, and skirtings. As many of them are in the nature of novelties and specialities, price has not interfered so much with the sale.

The Continental trade in woollens has been one of the worst for years, and only in high-class goods has there been anything worth speaking of. The American trade is almost a dead letter except in superior fancies. The South American trade has been depressed, but there are signs of an improvement, and also of an increasing trade with the colonies. The Japan trade is disorganized on account of the dispute with Russia—and China is not much better off—so that the dearness of cotton, which figures largely in goods for export, has practically shut out profits. India, however, has been an exception and has done well.

#### Huddersfield.

Trade in 1903 has been of a very fluctuating character, and the year closes with a less hopeful spirit prevailing than there was at the beginning. The weather conditions have all through the year been against a good season's trade, for when it was not wet it was too mild for a good winter's trade. Then the drought in Australia caused a shortage of wool, and this had a tendency to disturb the relations of the merchants to the manufacturers. While the former held aloof somewhat in giving orders, the others were at their wits' end to know how to get in the goods at prices which would be remunerative. This resulted in very keen competition. A further disturbing cause has been an unaccountable change in the taste of the people, either expressed or implied. This has resulted in the fancy worsted department having been depressed for more than half the year, as detailed elsewhere. The comforting feature of the year's business is that as far as one can judge, the proportion of bad debts has been comparatively small. The long-credit system, however, is still in force—no one having been bold enough to launch out on the uncertain waters of the shorter credit system—and one cannot say with confidence whether the bad debts will ultimately prove to be large or small. Another satisfactory feature of the trade of Huddersfield is to be found in the splendid improved conditions under which the workers are enabled to follow their employment, as compared with a time within the memory of the writer. Wage disputes have been rare and insignificant in character, and the tendency is in the direction of more amicable relations between employers and employed, and wages have a slight upward tendency. It is also satisfactory to note that there have been very few failures of local firms for great amounts or of distant firms affecting the status of local firms. To make up for any deficiency in the break up of firms others have started, but mostly they are in a small way.

#### FOREIGN AND COLONIAL.

The Continental demand was maintained during the first half of the year, but during the second half it fell away. In regard to the "tropical" cloths, it is noted that German and Austrian manufacturers are turning out cloths of such good quality, finish, and design as to compete seriously with cloths made in this district. In the ordinary cloths the German taste is more after the English type than any other of the Continental nations, and it is calculated that fully one-half the business done with Germany in cloth is done with Huddersfield. France demands goods with more "imagination" on the part of the designer, and the Italian seeks novelties. When one remembers all these differing tastes, and that they are supplied by Huddersfield, it will be seen how infinite must be the variety of goods sent out. The German tariffs have hit Huddersfield goods very hard, but notwithstanding that there has been a consistent trade done. How long that will be maintained no one knows, but it is satisfactory to know that Germany has extended the operation of the most-favored-nation clause up to the end of 1905, which means that there will be no disturbing influ-

ences at work during that period, at any rate beyond those of which we are at present cognizant. With France, in the very highest goods which are transhipped to South America and other markets, a good business, comparatively speaking, has been done; and as securities in France are high there has been little or no anxiety felt on account of business. The rapprochement recently established between ourselves and the French nation, though it savors of politics, is expected to have beneficial results commercially, and as Huddersfield has a fair share of the French trade, it is believed it will benefit indirectly from the better understanding. The Italian trade has been of a fair to middling character; but with Belgium business has been pretty much on the lines of former years. Taking the Continental trade as a whole, there has been little or nothing to complain of. With the United States of America, the story is different, as the figures show. The total amount of exports from Huddersfield district in 1902 was £301,853, which was the highest since 1898, when the figures were £305,370. The returns up to the 19th inst. are £233,780, of which £55,471 represents woollens and £88,578 worsteds. The value is a diminishing one, and those engaged in the American trade despair of its ever improving. But one is bound to admit that the figures for the past month's are more in favor of worsteds than of woollens. While the United States report is of a gloomy description, that concerning her neighbor, Canada, is the reverse. With Canada business has all the year through been of a very satisfactory character, and the same classes of goods have been sent out as formerly. There is a disposition in Canada to treat the Mother Country more favorably than other nations—Germany, for instance; and, considering the heavy tariffs against some classes of our goods sent out and the fact that the Canadian manufacturers are entering into competition with us in certain directions, our business relations with Canada have been well maintained. Among interesting items connected with Huddersfield and its trade, may be noted the fact that during the year Mr. Henry Martin, of Martin, Sons & Co., Lindley, the largest firm of woollen and worsted manufacturers in Huddersfield, and Mr. Edward Fisher, of Messrs. Fisher & Sons, shippers, Huddersfield, each presented £500 to be invested to enable students from the Technical College to go to the Continent for the purpose of learning Continental business methods and languages. Immediate prospects are not of a very hopeful character. During the year an important plebiscite was taken of a great body of the weavers—though not of all, as in some cases the employers imposed conditions which could not be complied with—as to whether they would be willing to adopt the principle of one weaver attending to two looms. The question was put in the following form: "Are the weavers of Huddersfield and district prepared to work two looms to one weaver, provided that arrangements can be made between the Masters' Association and the Weavers' Association to prevent the displacement of the weavers at present employed, and for a scale of wages to be prepared under which the weavers can earn higher wages for working two looms than they can at present earn by working one loom only?" Two subsidiary questions were put in continuation: (a) "If applied to plain white worsted goods; (b) If applied to one loom with an easy worsted fancy make with only one color of weft?" It was thought that the weavers would accept a proposition such as that, by which it was expected that a good deal of Huddersfield's lost trade would be recovered, but the weavers decided against it by 5,217 to 41. There were 48 neutrals. It is fully expected that another attempt will one day be made to induce the weavers to adopt the principle.



## DEWSBURY AND BATLEY DISTRICT.

The staple trade during 1903 cannot be said to have enjoyed much prosperity, and the prospects for the coming year are not good. The continued high price of the classes of wool used in the district has troubled manufacturers here, where so much of the cloth produced is of the "low" class very considerably, but there is some shrinkage now, and 1903 may therefore turn out to be a fairly profitable year, even though the output in the several mills be below the average. Last winter was anything but a good one for makers of the stouter cloths, and this finds them in bad case owing to the weather having been mild and open. "Stouter" has not the meaning it once had, when pilots and winceys were all the rage, but refers to goods for overcoatings of no great weight but well spun and woven, many of them subjected to the rain-resisting process. In Batley there was a large production of these useful cloths, and business in that town, both in them and the ordinary run of cheap goods in tweeds, etc., has been fairly brisk. Still, makers could have produced far more, and at the present time they find the demand shrinking. In Dewsbury, the year has not been satisfactory even to leading firms having large connections both at home and abroad, for orders fell off early in the spring, and at midsummer, when the strongest "push" prevails, as a rule, there was but little recovery. In the autumn greater quietness set in, and the year will finish dull. The goods made have included the medium and better-class tweeds, for which the town is famous, also ladies' costume cloths, skirtings, and tropics. The use of the latter for pyjama suitings has greatly extended. Here, as in the other towns and townlets of the districts, not a little short time has been run in order to keep down production. In Birstall, and to at least a similar extent in Morley, the year will have proved satisfactory to most firms. The shrinkage of the exports of ready-made suits for men and boys has affected both towns, the latter especially. Women's fabrics for jackets, coats and skirts have had a moderate vogue. Mirfield and Ravensthorpe manufacturers have not had a good year, but the first half found them fairly well employed. In Ossett mungo manufacturers have suffered to a less extent than their neighbors, the Continental demand, except from Germany in spring and summer, having a little exceeded anticipations. For the past six weeks or more business has not been active. Contrary to what has been the case with woolen manufacturers of all classes, machine-makers and engineers—with perhaps an exception or two—have done well. Improvements in spinning, weaving, etc., are constantly going on, and firms must have the most up-to-date appliances, even if trade be bad, hence the greater activity amongst iron founders, engineers, etc.

## HALIFAX.

The lack of business and dwindling profits have all through the year marked the piece trade. Enhanced wool values have told heavily upon the worsted coating trade. It has been a dull year throughout, and it ends so badly that manufacturers would be only too happy to blot it out of memory. Recently there have been cases even of bankruptcy. Quite a number of looms have been idle all through the year. The condition of the woolen trade has not been so very disheartening, some Government contracts having been secured, and those engaged in it are not without hope as to the prospects of the immediate future. The yarn market, like everything else, has been dragging through the year. Botany spinners have had their work cut out to hold their own, and to keep machinery going even part of the time. The run on tweeds has occasioned much of the de-

pression in this neighborhood. Merino values, except for slight speculative fluctuations, have been fairly maintained. Crossbreds dropped lower and lower till the autumn, when there came a sudden jump, in some instances of 50 per cent., but the yarn market was not able to follow it. The middle of the year was marked by a fair demand for Germany clearing the heavy stocks of crossbreds and preventing universal short time. Prices of crossbred yarns are still much below their cost, and to obtain orders is exceedingly difficult. The fancy yarn trade for fine coatings is described as very disappointing. The furnishing branch has been better than last year, but below the average year. Bunting business is at a standstill, the market having been glutted at the Coronation. The year closes with a good deal of worsted machinery unemployed. The carpet industry of Halifax and Bailiff Bridge has been about an average, keeping looms moderately employed but never over-taxed. The strain of the recent war still affects it, and matters have not been improved, from a manufacturing point of view, by the smartly enhanced prices of wool and other raw materials. A continuance of these, and it is on the cards that the manufacturers will issue advanced lists.

## KIDDERMINSTER.

There have been remarkable changes in the value of the raw material in the past year, but so far this alteration has not had a corresponding effect on the price-lists of carpets. The severe and long-lasting drought in Australia had its natural effect in diminishing the supplies from that quarter, and the fear of what the results might be, as the shortage was more and more felt, led consumers to anticipate their wants freely when the opportunity offered. Values consequently advanced at each series of sales. The high price of merino wools checked their consumption, and these being the wools in which the shortage was the greatest, the greatest danger to consumer and speculator lay in these wools. Spinners, who could do so, gradually drew off the merino type of wool, and worked their machinery on to the finer crossbreds. The latter advanced correspondingly in price, till they became 50 per cent. higher than at the end of 1902. Afterwards the lower or stronger crossbreds were affected. A year ago these and similar English wools stood at an extraordinary low value, and no one remembered the price of Lincoln hogs and wethers being at such a low level as they stood at before the change began. The fashion ran upon stronger wools and fabrics, and it has had the effect of doubling the price of the wools in twelve months. In sympathy with colonial wools; English wools were affected, and advanced, but never quite to the extent of colonial wools, except in the very strong classes. The English farmer has no doubt got the benefit of some 15 to 20 per cent. advance on this year's clip, though that is only a portion of what the general advance has been to the end of the year. A slight improvement is again being shown at the end of the year, and this arises, perhaps, from the shortness of stocks generally in the hands of dealers. Spinners have been able to keep their machinery running better in the last twelve months than in the period affected by the South African War, but still 1903 cannot be by any means regarded as a good year in this branch of trade. The difficulties in obtaining wools and the advances have been such that they were never able to bring their customers up to the level of the price of the raw material. They are not, in fact, getting even now the equivalent of the advance in wool, and they are supplying their customers out of earlier and more cheaply purchased wool. In the carpet trade business has been, no doubt, considerably affected owing to the war having curtailed the spending power of the country. Carpets are re-



regarded as a luxury, and when the spending power of the country is curtailed, the demand for carpets is curtailed, and they are among the last things to feel the effects of any general improvement. At the same time firms who have been able to run their machines fairly well will no doubt have a satisfactory stocktaking. Continual complaints are to be heard of the imports of foreign carpets, but these are, generally speaking, of a spasmodic character. As to the export of carpets for the first eleven months of the year, they increased from 7,108,800 yards, in 1902, to 7,943,500, in 1903. Of this increase of 834,700 yards Canada accounted for 625,400 of it. New Zealand took 200,900 yards in the first eleven months of 1902, and 312,100 in the corresponding period this year. The United States took 347,600 yards, or nearly 12,000 yards more than in 1902. Though this is an increase, it is comparatively insignificant, especially so when compared with the time when half the looms in Kidderminster were said to be running on American orders.

It is not easy to forecast the prospects of the carpet trade in the coming year. If the general trade of the country improved, the carpet trade would no doubt feel the benefit of it, bearing in mind that it is a trade that ebbs and flows appreciably with the prosperity of the country as a whole. In the matter of exports, if there were the same proportionate aggregate advance as in 1903, compared with 1902, the carpet trade would be all the better for it, but the table of exports shows too much falling off in individual cases for any safe deduction to be drawn as to what the prospective colonial and foreign trade may be in 1904. Though materials have become dearer during the past year, the price-lists of carpets have not yet undergone any change.

#### LEICESTER.

Leicester spinners have no satisfaction or pleasure in making up their accounts for 1903. Contending with constantly rising raw material on the one hand, with the keenest competition for yarns bought from hand to mouth in comparatively retail quantities, the whole business has been irritating, unsatisfactory in quantity, and certainly unprofitable.

#### SOUTH OF SCOTLAND.

During the past year the South of Scotland woolen industry has gone through a very varied experience. The year opened with bright prospects, but subsequent events produced much poorer results than were anticipated. The decided advance in the price of raw material put a sudden check on trade, and manufacturers and spinners found they were unable readily to obtain the advance on the manufactured article necessitated by this rise in price. It was hoped that this difficulty would disappear as the year advanced, but unfortunately this was not the case, as the shortage in all classes of wool kept the price up; indeed, the scarcity caused a substantial advance. From these causes buyers have held off from providing for more than their immediate wants, and as a result of this holding off a fall has shown itself towards the end of the year, and this has a tendency towards creating an impression that a further fall will take place at the first London sales next year. During the year cheviot wools, which were in demand, had a good sale at a considerable advance in price, and at the present time these wools are cleared out. There are other causes which have affected the industry prejudicially. The poor spring and summer proved highly detrimental, and weather is now a rather important factor in the trade, manufacturers having to depend more and more on the home market. Scotch tweeds are not now ordered by the Continent and the United States in any great quantity, and in this respect the trade has lost what were

once valued customers. The general effect of these various causes has been a state of affairs which is telling against the manufacturer and causing considerable idleness amongst the workpeople. A large number of carding and spinning frames have also been thrown out of work, and spinners as a rule are inclined to explain this as the result of foreign competition. The prospects for the first season—winter, 1904—are not promising, no orders having yet been given although manufacturers have been showing styles for some time.

#### DUNDEE.

In jute, the staple industry of Dundee, the year opened with an ordinary trade. Quotations for the raw material were about £13 17s. 6d. to £14 per ton. Soon, however, the Indian Government issued a forecast of the crop that alarmed the dealers. There was immediately a great deal of buying on the strength of this forecast; but the position was entirely changed by the issue of the final forecast, which predicted an unusually large crop, and also stated that the acreage sown was much greater than was indicated in the first forecast. The immediate result was a sharp fall in values, and native firsts ultimately touched £12. Since that time the large consumption in India and the numerous buyers, even of small lots, have sustained prices, and at the close of the year the market is firm at £12 15s. to £12 17s. 6d. Through the year the rates for leading qualities of yarns have varied very little. For 8-lb. cops 1s. 5d. was occasionally reached, but the average figure has been 1s. 4½d., and for warps 1s. 5½d. to 1s. 5¼d. Good yarn has been 1s. 7d. to 1s. 8d. The critical position in the Far East induced holders of jute to refuse to sell towards the end of the year in the hope that a rise in price might result if war was declared. The most interesting feature of the jute trade during the year has been the extraordinary demand for common hessians for the Argentine. The demands of the South American markets have been astonishing. First the Calcutta market was cleared, and then buyers came to Dundee, where stocks, which were becoming alarming, were also cleared off. The price consequently stiffened, and as the demand was persistent, a good many looms are engaged straight on until the middle of January. This was most fortunate for the Dundee trade, as it undoubtedly averted a crisis. Jute manufacture in India increases rapidly, and year by year Dundee finds India an even more formidable rival. It may be remarked that merchants and manufacturers alike complain with justice that, be the forecast of the crop favorable or the reverse, the Government officials ought to have known correctly and stated accurately the exact number of acres sown. In linen the season opened with moderate prices for flax, but before spinners had time to think or buy values began to rise. Riga K, which at one period of the year was not easily sold at, say, £26, was towards the end fetching £33, and dew-retted flax, which opened at £34, was quoted at £48 10s. Tows were more difficult to buy, as much as £39 10s. having been paid for some sorts. The cause of this sharp rise was first of all the shortness of the crop, and also the fact that foreign spinners, who get higher prices for their yarns, took courage to purchase at the opening. Therefore the position of Scottish spinners without stocks of the raw material is awkward. The trade on the whole has not been remunerative in the Dundee district. Arbroath in heavy linens and canvas has been very dull, with much machinery silent; whilst neither Brechin nor Forfar in the linen branches has been prosperous. Even in the latter part of December, buyers for the home linen trade refused to believe in the great rise in the value of flax, and hesitated to give any adequate increase in the price of linen

goods. The peculiar nature of the French tariff affects the linen industry seriously. The only linen district in Scotland that has enjoyed a favorable year is Fife. In Dunfermline the looms have been steadily fed with foreign, mostly Belgian, wet spun yarns, and to prevent the import of these would mean an immediate injury to the weaving of damasks and other such goods. Possibly it might lead even to the transfer of the weaving of these fabrics from both Belfast and Fife. With flax up in price and the manufactured articles refusing to follow the advance, the close of the year has been gloomy enough. But with the new year there are hopes that better prospects may unfold before this old Scottish industry, upon whom so many households depend.

#### BELFAST.

At the beginning of the year, as at its close, the future supply of flax was a cause of anxiety with spinners and manufacturers. An advance quoted in Baltic flax and small local markets kept the anxiety alive. Market conditions have been adverse to flax spinners, and these have been intensified by the speculative movement in cotton. Although the growth of this flax fibre in Ireland is now very much less than it was in former years, the decreased sowing of 5,075 acres in 1903, when compared with that of the previous year, increased the general solicitude and apprehension of manufacturers as to future profits and expansion of their operations. In the spring season the want of rain hindered farmers from sowing, and the season for growth was cold and unfavorable to the maturity of a crop depending on a warm, dry atmosphere for the production of good quality. Prices current in the different local markets have been from 5s. to 7s. 6d. per stone, indicating low and middling fibre. Even at the exhibitions under the care of the agricultural and technical department, the highest price has only been 7s. 6d. per cwt., which was paid for only one or two lots. In the previous year several lots prepared under the instruction of this department were sold at 10s. and 11s. per stone. A large proportion of the Irish flax—as much it is said as 50 per cent.—is exported to Scotland, England, and the United States, where it is used for making thread, for which it is specially suited owing to its toughness. For some years past there has been a continued decrease in the number of spindles at work. During the last year the machinery in one concern was broken up, and that in another has been idle for some time. As compared with the year 1879, the spindles in 1902 show a decrease of 73,647 in Ireland. Prices of linen yarns, from the lowest point, have advanced in the twelve months from 6d. to 1s. per bundle. Owing to the sensitive state of the flax markets, manufacturers have labored under constant pressure to improve their positions, and this has rendered trade a dragging operation. At no time has the demand been more than an ordinary one, limited to actual requirements. One new feature has been the production of fancy linens, in a variety of colors, for women's dresses, and this has undoubtedly increased the turn-off from the looms in Ulster, and has met with encouraging success. Almost at the close of the year everything produced from flax has followed it in an upward movement in price, the natural consequence of which has been a rush for goods, especially those suited to the urgent demands of Christmas. According to the returns received, the export of linens from Belfast for the year will be about equal to that of 1902, or a little under 50,000 tons. The total value of linen piece goods sent from the United Kingdom in eleven months was £3,691,874. Whilst minor improvements are being made in machinery, no large comprehensive invention involving extensive alterations has been patented during the year. Automatic looms have not as yet received much attention, al-

though in one concern a patient effort is being made to adapt them to the manufacture of linen goods.

## BRUSSELS AND WILTON CARPETS.

THEIR CONSTRUCTION AND MANUFACTURE, WITH PRACTICAL POINTS ON DESIGNING.

Considering both fabrics in a general way, from a technical point of view, the two are really a similar fabric, there being little difference in the process of their manufacture.

#### BRUSSELS CARPET.

Brussels and Wilton carpet manufacture had its origin in Tournai, Belgium, from where it was introduced into Wilton, England, and from there into this country.

The manufacture of Brussels carpets has during the last quarter century changed wonderfully. Where twenty-five years or so ago, but one or two standard qualities were made, at present they are made in any number of grades, a feature which later on will be dealt with more in detail, the object in many cases being to trade off an inferior fabric for a better make. Another point worth mentioning is the fact that considerable improvements have been made in the looms for the manufacture of Brussels carpets. The standard width of Brussels carpets is 27 inches, i.e., three-quarters of a yard.

Brussels carpet is a warp-pile fabric in which figures are produced by raising over a wire different solid colored warp-threads at certain places according to the design.

#### BRUSSELS VICE VERSA TAPESTRY CARPETS.

Brussels carpets are of a far superior character, as respects color, quality of material used and the structure, than the tapestry carpets. Although at a first glance they are to the less experienced person so similar in appearance that they might readily be regarded, on a casual consideration, as fabrics of the same structure; but, when the principles on which the design is obtained in the two kinds of carpets are more closely examined, it will be at once seen that there is practically no actual resemblance between both, since in connection with Brussels the pattern is a woven effect, whereas in the tapestry carpets, the same is merely a print affair. Examining both kinds of carpets it will be noticed that the Brussels fabric has several advantages over tapestry carpets.

In Brussels carpets, the colors used are generally "fast," as the yarn is hank-dyed and not colored in the warp as is done with the tapestry carpets.

Again, in Brussels carpets the pile is fuller and made of better materials while the body of the fabric is not as much due to strengthening (stuffer) threads as is the case in connection with tapestry carpets. In Brussels the worsted yarns used in the formation of the pile being used simultaneously also, considerably, as stuffer threads to impart body to the fabric, thus making the carpet more pliable and consequently resisting more wear than a tapestry carpet will give; a good four or five frame Brussels carpet thus outlasting in wear two or three tapestry carpets.

Another point of advantage to Brussels carpets is the fact that its pattern is more pronounced, each portion of the design being clearly and distinctly developed, as compared to tapestry carpets, where the figure is always more or less indistinct, especially at the outline of a figure, arising from the system on which the pattern is produced in the fabric. In this case the design is printed on to the pile-warp threads, previously to weaving, and when in turn the change of one color to the other—considering each pile

warp thread—cannot come up distinct in the loops, the change of colors—from one color to the other—on every warp thread, must tend to blur at their point of contact, this feature at the same time being heightened by the difference in take up of the pile warp during weaving.

#### CONSTRUCTION OF BRUSSELS CARPETS.

Brussels carpets are technically classified by "frames," or, in other words, by the number of different colors called for in a vertical row of squares on the designing paper, as also in one row of loops, considered in the direction of the warp, in the fabric. In tapestry carpets, one double thread of worsted printed, according to the design, is used for one row of loops (warp-ways), while in Brussels carpets a similar double thread is used for each color as required by one row of squares, warp-ways, in the design. One color only from the frame is raised at one time for forming the loop, the other threads of the frame then not called for, resting in the body structure of the fabric. Therefore the thickness and substance of the fabrics is not so much due to cotton, hemp or jute thickening threads, as is in the body of the tapestry carpet, but the same pure worsted thread, which forms the face (loop-pile) in the fabric, will at every place not called for for forming loops by the design, form part of the body of the fabric.

As mentioned previously, each color of the pile warp in a Brussels carpet requires what is technically called a separate frame, and the manner in which the various colors are controlled—in other words, in which they are concealed from, or brought into view—is an important factor in the manufacture of this carpet. On examining a Brussels carpet, it will be observed that the individual threads forming the pile seem either to be composed of several colors, or to be substituted by yarn of other shades, according to the section of the pattern being formed. For instance, in the same line of the design, looking at the fabric lengthways, apparently in the same thread, as many as from two to six colors, such as black, green, slate, scarlet and yellow, form the pile in succession. If these effects are not due to a variegated yarn, they are the result of the employment of distinct threads, each of which is so controlled that it only appears in the pile when required to produce the design. Effects of this order are due to changing the positions of the respective pile warp threads by reversing the weaves. The several shades of a Brussels carpet are manipulated on this double weave principle of intertexture. To obtain a three-frame pattern composed, say, of black, blue and green, at least three separate weaves are necessary—one for each shade. Thus the weave used in forming the shed in the warp for the black pile is so arranged as to depress the blue and green, while that for giving the blue pile conceals the black and green pile threads, and lastly, that for producing the green pile hides the black and blue pile ends; so that, by an appropriate application of these respective weaves to the design, the colors are brought up in the figure wherever required.

The ground warp in Brussels carpets is interlaced with the filling on the common four harness basket weave  $\times \times$  arranged so as to have each two successive picks inserted in the same opening of the shed (of the ground warp), and only separated by the pile warps. One pick passes above, and its mate pick below, the pile warp threads holding the latter firmly secured between; thus, if the raising of the pile warp over its wire for forming the characteristic loop should be omitted, we would produce nothing more than a fabric interlaced on the common four harness basket weave having a stout packing or thickening thread in the centre.

#### FRAMES.

As mentioned before, Brussels carpets are graded by "frames." There are two, three, four, five-frame and in exceptional cases six-frame Brussels carpets.

Under "frame" we classify the number of different colors found in the different rows of squares in a vertical direction on the designing paper; thus a three-frame Brussels carpet has three different colors in one row of loops (warp-ways), in the fabric. Any of these three colors can at any other row of loops (warp-ways) be exchanged to a different color without changing the principle of a "three-frame" carpet.

A "four-frame" Brussels carpet will extend the number of colors for each row of loops to four colors. Thus, a "five-frame" Brussels carpet will show five different colors in one row of loops warp-ways. A "six-frame" Brussels carpet will extend these number of changes to six colors.

In Brussels carpets, the different colors used are variously distributed, one color being used to a greater extent than the other, etc. This method of using every pile warp thread at will, and in a different amount than others, requires us to use instead of ordinary warp yarn beams, hobbins, or miniature beams fixed in frames, or a huge creel, stationed behind the loom. The manner in which the different colors are controlled, in other words, in which they are concealed from or brought into view upon the face of the fabric is of great importance in the manufacture of this article.

Fig. 1 illustrates the section of a three-frame Brussels carpet. In the same, threads marked a and b represent the binder-threads. A, B, C represent the three different colored pile warp threads. Numerals 1, 2, 3, 4, 5, 6, 7, illustrate the section of the wires as used in the formation of the loop. Shaded circles show the sections of the ground or body filling—jute, hemp or stout cotton being the material for it.

The binder warp is drawn in two common harness frames, which are placed in the rear or front of the Jacquard harness. The face or pile is drawn in the Jacquard-harness, which is tied up for as many sections as there are frames in the carpet, so that in the present example of a three frame carpet we must use a 3-section tie-up.\*



Fig. 2 shows a perspective view of such a three-frame structure, from which it will be seen that when the pile warp thread A, as shown in outlines, forms a loop, pile warp threads B and C rest in the body of the structure, as stuffer threads. In the same way when pile warp thread B, shown shaded, forms a loop, threads A and C act as stuffers. Again when pile warp thread C, as shown in full black, forms a loop, the other two pile warp threads B and A, respectively, act as stuffers to the fabric. Thus in a three-frame Brussels carpet two pile warp threads of each frame act always as stuffer threads to the structure.

Brussels carpet varies in pitch from 8 to 10 (loops per inch), 9 to 9½ loops being the most generally found, for which reason no detail can be obtained in the fabric less than 1-9 of an inch.

#### WEAVING.

The reason for grading Brussels carpets by frames is this: The worsted pile warp, which forms each frame of the

\*For tie-ups of the Jacquard-harness, the reader is referred to "The Jacquard Machine Analyzed and Explained,"



stance of the fibre. When the wool fibre is subjected to friction, especially in hot water with a slight quantity of alkali, these epithelial scales become readily matted and interlocked with each other—"felted," as it is called. Yarns which become felted in the scouring operations are much deteriorated, as they have to be forcibly torn apart, and this naturally weakens and destroys the fibre.

When a wool fibre is examined under the microscope it will be observed that the free ends of the scales all point to the free end of the fibre—that is, the end which is not attached to the skin of the animal. Now, when two of these fibres get side by side with their scales pointing in the opposite direction, the scales interlock one with another, and the two fibres become so closely connected as only to be separated by the exercise of some considerable force, which results in a weakening of the strength of the fibre. When the number of these fibres are multiplied, as in the case of a piece of woolen cloth, and felting of the fibres is brought about by the process known as fulling or milling, it is accompanied by the fabric becoming more compact, thicker in texture, shorter, and narrower.

The great importance of preventing felting during scouring and dyeing is well known to all, but it becomes doubly important when the microscope reveals the extent of the damage it causes to the fibres. Woolen yarns felt more readily than worsted ones, as in the former the staple is short, and the fibres are lying in different directions. In worsted yarn, however, the fibres are longer, and are inclined to lie more in one direction as when growing on the sheep's back:

This felting of wool is produced by using too high a temperature either in the scouring or the dyeing processes, or by excessive handling of the yarn, especially in liquids which are slightly acid, as in dyeing, or slightly alkaline, as in scouring. Dilute acids have the property of opening up these exterior scales of the wool, giving it a more serrated appearance, which is visible under the microscope. The scales being opened, dye solutions can enter into the interior of the fibre better, and there become fixed within the wool, which then becomes permanently dyed. Hence, the value of the addition of acid to the dyebath. The acid, however, has some other functions to perform in connection with the dyeing operation. Under the outside sheath or cuticle, with its overlapping scales, there is the cortical substance of the fibre itself. Upon this depends very largely the elasticity and color of the wool.

The substance consists of almost innumerable minute cells, all tightly bundled together. By treating the wool with suitable chemical reagents—strong sulphuric acid, for example—these masses of spindle-shaped cells can be separated, and their shape observed with the microscope. They are found to be long and tapering in shape, ending in a fine point at each end. Dr. F. H. Bowman, to whom we owe most of our present knowledge of the internal structure of wool, has had the patience and industry to count these, and he tells us that in a cross section of the fibre may be counted 1,500 of these cells, while there are about 6,000 of the scales in an inch of wool fibre. This cellular substance of the wool is what we might term the marrow of the wool fibre, as it constitutes nearly the whole of the inside portion of the fibre.

In many specimens of the wool fibre there is a third part—that is, a central or medullary portion—which, when present, may run through the whole length of the fibre, or it may only appear in detached portions. It has been found, however, that wool which exhibits this medullary portion is generally stiff and more of a hairy nature, not so well adapted for the ordinary purposes of textile manufacture. The finest wool, that of the merino, does not show any core or central medullary cells.

It is interesting to mention in passing that the spindle-

shaped cells have a much greater affinity for dyes and coloring matters than the external scales. Wool which has been "extracted" or "carbonized" (that is, woolen stuff mixed with cotton, which has been treated with sulphuric acid to remove the cotton) is found to dye a much deeper shade than the ordinary wool for the reason that the outer scales are opened out very much, and so expose the internal scales.—The *Le. tile Mercury*.



### MURVA FIBRE FROM THE STRAITS SETTLEMENTS.

An enquiry relating to the value of Murva fibre grown experimentally in the Straits Settlements was recently referred to the Imperial Institute by the Commercial Department of the British Board of Trade. Owing to the small amount of fibre available, a complete chemical examination could not be carried out, but the following determinations were made by the usual methods. For comparison, the results furnished by the examination of other specimens of this fibre are also quoted:

	Moisture per cent.	Ash per cent.	Cellulose per cent.	Length of Ultimate Fibre.
Straits Settlements . . . .	9.9	0.7	75.9	1 — 3 mm.
Grenada . . . . .	9.5	1.4	72.7	1 — 5 mm.
Assam . . . . .	9.4	0.7	75.6	1.5 — 3.5 mm.
Colonial and Indian Exhibition (Cross & Bevan) . . . . .	9.7	...	73.1	1.5 — 3 mm.

From these results it appears that the fibre from Selangor is fully equal in quality to specimens obtained from other sources.

The fibre has also been submitted for commercial valuation to two leading firms of fibre brokers, who were informed of the favorable results which it had furnished on chemical examination. One firm reports that the sample is a very strong, clear, hard fibre, of good color, but rather short and tapering; it is coarser, and not quite so soft and pliable as is usual for the fibre of *Sansevieria zeylanica*. Owing to the want of regular supplies the fibre has not a recognized position on the London market, but consignments of long staple have been sold at very high prices. The value of the present specimen is given at about £35 per ton (Sisal hemp being now £37 per ton), but if long and of similar quality it would be worth £40 per ton and upwards. The other brokers to whom the fibre was submitted value it at £33 per ton, and £30 per ton if "bright white," at which prices it would meet with a ready sale.



### THE WOOLEN INDUSTRY.

A local journal publishes a report that the "woolen trade is in great danger." This announcement might cause considerable disquietude were the trading public not acquainted with the fact that the depression in question is due to causes which are abnormal and temporary. For some time the textile trade in New England has been flat. It has been in a condition that may correctly be called languishing. Curtailment of production has been the order of the day, and it is even hinted that manufacturers there have encouraged strikes to give them an excuse for shutting down. It is well known that in Old England, scores of mills have for months past been running on short time. In Lancashire the situation has been going from bad to worse until it has culminated in a crisis that has closed hundreds of mills and cast thousands of operatives adrift on the public charity.

So serious have things become in the Manchester dis-

trict that the home Government has been urged to adopt measures of relief, by organizing an emigration scheme which would transfer the surplus labor to some other part of the imperial dominions. The cause of this state of things is in part due to excessive plant, which induces over-production, but mostly due to the enormous disparity, for months, between the price of raw material and the manufactured article. Twelve months ago, Egyptian cotton stood at forty-eight per cent. lower than it does to-day; and people on this side of the Atlantic need not be told of the embarrassing vagaries of Americans during the same period. It will be naturally retorted, but what has this to do with woollens? It has everything in the world to do with woollens, for the simple reason that, in both cases, the same causes are at play.

Crossbred wool, which cost sevenpence a pound last September, costs at this moment a shilling, and the end is not yet. All this time the price of finished goods in both cases, have undergone no proportionate change. This is notably so in the case of woollens, which, outside of merinos, have hardly at all participated in the raw advance. The situation in Yorkshire, as compared with Lancashire and Canada, is anomalous, and would be perfectly inexplicable, save on the supposition that the Yorkshire men, with more pluck and greater resources, covered themselves twelve months ago in a market at zero, with raw material, which is not yet exhausted, while Lancashire men and Canadians contented themselves to buy from hand to mouth and take the risk of being left out in the cold. Another cause which aggravates the present situation is the abundance of manufactured goods. Buyers are to-day under no immediate pressure to purchase. Indeed, it looks as if, with few exceptions, the general interest would not suffer materially if all the mills in the world were closed down for a couple of months. There is too much manufactured goods at the moment and too little raw material.

Corn, cotton and wool can find a ready market, while manufactured goods are a drug. The inference is obvious. When the situation of the market changes, manufacturers must change with it, otherwise it stands to reason that they will be left high and dry. People must adapt themselves to new conditions if they wish to continue business. If the public taste, with the caprice habitual to it, wants a change in style, it must be forthcoming, otherwise the caterers for the public must be prepared to face a falling off in their returns. If makers can supply what the public is eager to have, there will be no stinginess about the price, whereas a concession on an article that is not wanted, will not sell it. It has come to this, and it has greatly altered the situation. The value of an article now is more in the style than in the quality. This is particularly so in textiles. It is sincerely to be hoped that the Canadian woolen industry has sufficient inherent grit to withstand the temporary strain which the exigencies of a most peculiar market have put upon it.

There is a good deal of capital invested in woolen mills in this country, and every right-minded person will be ready to deprecate any serious impairment of its effective use, but no government can be expected to protect individuals or corporations from the consequences of unforeseen conditions or errors in their own judgment.

If a man go into business and fail, losing every cent he ever earned, that accident gives him no claim on the government. Enterprises of such magnitude as to assume national dimensions though no better off in this respect, often receive special protection from government until experience has acquired for them a skill and proficiency which will qualify them to hold their own against all comers with the other protected and unprotected industries of the coun-

try. Those who believe in moderate, temporary protection for certain industries in this country, by no means imply in this, that a government with a normal conflict of interests pressing upon it can be expected to be ready at a given signal, with a Chinese wall to tide over every unusual disturbance that has deranged business for a few months.

The original tariff of 1878 was, under the circumstances, a fair measure of protection till encumbered with those specific duties which levied an extra 40 per cent. on the laboring classes, and finally drove the country to revolt. If any trade in this country has been pampered it is the woolen trade. Indeed, there is some reason to fear that the coddling it has received has emasculated its stamina, and rendered it unfit to stand the bracing and invigorating brush of a healthy competition. To-day imported woollens in the net cost fully 30 per cent. to lay down. There is the duty, 22 per cent.; packing charges, inland carriage, handling at Liverpool, marine insurance, freight, interest on cash outlay on the various items aforesaid enumerated, all of which cost nearer 35 per cent. than 30 per cent. to the person who imports the goods. On certain classes of goods it can be verified that the packing charges are  $2\frac{1}{2}$  per cent. of the value of the invoice; and these same bulky goods, carried by a measurement and not a weight standard, must cost for freight alone five per cent. more. There is no romancing about this. It is all a question of figures, and, all things considered, it seems that an importer, to be sure he is on the right side, should not charge himself less than 35 per cent. to lay down British goods.

If, after nearly half a century of apprenticeship, and the steady improvement consequent on the perfecting of methods, an industry in this country cannot hold its own with a protection of 35 per cent., there is something radically wrong somewhere. For the oldest industry in this country to come first forward at this hour of the day, and admit that after forty years, this is all it has been able to accomplish, is anything but encouraging to people who have reason to be proud of the general achievements of Canada. But no one expects the fate for these industries that their friends predict for them.

If this venerable industry has not even yet passed the state militant, let its friends in a straightforward way approach the Government and give categorical reasons for the despair that is in them. They cannot expect that a mere announcement of their distress in a public journal will be accepted by the Government as evidence in chief. If they can prevail upon the Government to do anything, this must be done in the fierce light of other interests. The enrichers of this country for the last twenty years have not been manufacturers. The chief supporters of Government and the largest contributors to the public treasury are the transportation systems of Canada and its unsubsidized producers, not yet honored with the name of manufacturers. There is something loose and inaccurate in confining the name of manufactures to a set of trades of a given description; corn, cheese, live stock, farm, garden and orchard products of all kinds—even forests, mines and fisheries are anything but raw materials. They all need capital, skilful exploitation, assiduous and laborious development, and are all liable to the risks from vicissitudes common to so-called manufactures. These last have a double claim upon the Government; first, because they are the very basis and foundation on which all others rest; and second, because they are the largest contributors to the wealth of this nation.

A government, if it deserve the name, must be impartial. Before making a change in any one thing it has to consider how that change will affect a dozen other things. As every



one is equal before the law, so every industry shall be equal before the government. There should be no favorites or pets in the family industrial. Each member should be advanced according to his claims, and his claims should be in ratio of his merits, and the standard of merit should be the measure to fitness to promote general utility, and the greatest good of the greatest number.—J. McG. in the *Montreal Witness*.



### SHEEP BREEDING IN CAPE BRETON.

That there is room in Cape Breton for an immense development of the sheep-raising industry will readily be admitted. In this country we are almost entirely free from the ravages of those diseases which interfere so seriously with the profits of the sheep grower in some other lands. Then, too, we grow in abundance nearly all the foods best suited for feeding sheep. We have excellent pastures in summer, and with turnips, etc., there is no lack of succulent food for fall and winter. Where clover hay and pea straw are not available, some other suitable roughage can usually be found. Oats and bran are everywhere convenient grain foods, while peas and beans may also be provided in many localities. Unfortunately, too, we have in nearly all parts of Canada an abundance of weeds, which may partially be kept in check by maintaining large flocks of sheep. It is said that 85 per cent. of our common weeds are readily eaten by sheep, and consequently we find, as a general rule, that a sheep farm is a clean farm.

In a circular issued by the Commissioners' Branch of the Department of Agriculture at Ottawa it is pointed out that sheep breeders, like all other live stock growers, should start out with some definite aim in view. In Canada this will doubtless be the production of mutton for the home and foreign markets, with wool growing merely as a side line. The breed chosen should be one adapted to the purpose in view, as well as one for which the farmer has a liking. In addition to this, it must be a breed suited to the conditions of soil and climate prevailing in the locality. As a general rule the heavier breeds do best on somewhat low-lying or level land, while the lighter breeds prefer upland or even mountainous country. These characteristics are largely due to the nature of the soil in the district where each breed originated as has been shown by Mr. Primrose McConnell in his excellent work on *Agricultural Geology*. If a pure bred stock is to be kept, the farmer should choose a popular breed, or one gaining in popularity, in order to be reasonably sure of a demand for his flock. Whether the flock be pure-bred or grade, a knowledge of the anatomy of the sheep and of the methods of treating common disorders of sheep will prove of decided value to the owner.

In starting a flock only healthy, robust ewes should be selected, and all of them should be of the same type. They should be mated with first-class rams of similar type, and one of the same breed as the ewe flock, unless the farmer is crossing for some special purpose, and does not intend to retain the progeny for breeding. Each year the ewes should be carefully weeded out, only the best being retained; too many farmers in the past have followed exactly the opposite course, allowing buyers to pick out the best specimens and retaining only the cull females for breeding. By following the system of culling closely, a high degree of uniformity will in a few years be established in the flock. Every farmer knows that the presence of a few culls in a lot of animals always proves an obstacle to a sale at a remunerative price; there-

fore, great pains should be taken to have the flock of uniformly good quality.

Good, comfortable, roomy sheds or stabling for the cold and stormy weather are necessary. These need not be expensive, but should be well ventilated, free from drafts, and situated on dry ground. A large open yard, apart from that occupied by other animals, should be attached to their houses in every case, to allow exercise. Too much confinement in overwarm, ill-ventilated or drafty stables is fatal to success with sheep. On the other hand, comfortable quarters, regular and liberal feeding, plenty of pure water and a sufficiency of salt will go far to ensure their successful wintering and a strong crop of lambs in the spring. Very careful attention must be given at lambing time, but at other seasons comparatively little time need be spent in looking after the flock. Indeed, sheep require less costly buildings and equipment and less labor in caring for them than almost any other class of live stock.

Unfortunately there are two causes which tend to demoralize the sheep-raising industry in Canada, viz., the wholesale adulteration of many lines of imported woollen goods, and the ravages of dogs and wolves. The former renders wool-growing unprofitable, and the latter prevents the farmer from growing mutton sheep in many districts which are otherwise well suited to the business. That legislation is needed to protect the sheep breeder from these evils can scarcely be doubted.—Sydney, C.B., *Record*.



### OILED WOOLS.

#### SPONTANEOUS COMBUSTION IN THEM.

The production of spontaneous combustion in oiled wool or cotton fibres and fabrics is governed by many factors, and the exact conditions which lead to its development in the quickest manner are not thoroughly known. The character of the oils used has some influence also, as has the proportion of oil to textile material. If there is too much or too little oil, spontaneous combustion may not occur, for in the one case the excess of oil, by its cooling action, will prevent the temperature from getting too high, while in the latter case the amount of oxidation is not enough to lead to such a rise in temperature as will cause the mass to inflame. The question of volume of the mass of oiled material cannot but have some influence; in which direction it is rather uncertain, but probably the greater the volume the greater the risk, for there is more surface exposed to the oxidizing action of the air on the oil than would be the case if the masses were somewhat compressed.

The presence or absence of moisture has some influence, and so far experience shows that the presence of a small amount of moisture tends to promote spontaneous combustion rather than to retard it. Probably the moisture acts as a carrier of oxygen to the oil, or the high specific temperature of the water enables it to accumulate much heat, and so specifically raise the general heat of the mass. It has been observed in the case of cotton fibres that bales that have got damp in the process of extinguishing the fire are very liable to burst into flames, and the only way to avoid this is to open out the bales and allow the cotton to dry.

The general temperature of the place where the oiled material is stored will have some effect, for oxidation of the oils, and the heating of the wool, etc., are more likely to occur when the general temperature is high than when it is low. Whether the spontaneous combustion breaks out first in the centre of the mass or at the outside is not known with any degree of certainty. Cases have been known when combustion



has started on the outside, while in other cases the fire has started in the centre. The question of the flash point, or, perhaps, more strictly, the firing point, says the Textile Mercury, of the oil does not so much concern the production of spontaneous combustion as the extending of the fire when it has broken out. The lower the flashing and firing points of the oil, the more rapidly does the oil spread over the surface of bodies, because of its greater limpidity, and besides the rapidity of extension of the fire is greater than with oils of high flashing and firing points.

Having regard to the class of oils used in oiling wool, it is not easy to fix a safe flashing point. The oleines and oleic acid have comparatively low flash points—about 320° F.—and the establishment of too high a standard would exclude these, yet hydrocarbon oil with a flash point of 320° F. is of comparatively low quality, good grades range from 370 to 410° F. in flash point. The firing point is always higher than the flash point by from 50 to 80° F., varying in different classes of oil. An oil like olive, lard, neat's foot or cotton oils, if of good quality and fairly free from fatty acid, will have a flash point of 470° to 500° F., with a firing point of from 550° to 600° F., so that these are, apart from the risk of spontaneous combustion, safe oils to use, for their firing point is high, and, further, their spreading power is less than in the case of hydrocarbon oils. The question of price often precludes the use of these oils, although the extra cost may be counterbalanced by other advantages, less liability to defective dyeing of the yarn or cloth on which the oil is used, and greater value of the recovered oil or grease from the wool. Where price is a consideration, the best oil to use in the oiling of wool, one in which the risk of spontaneous combustion is eliminated, while the firing risk is also slight, would be a mixture of 80 per cent. of good olive, lard, neat's foot, or earthenut oil with 20 per cent. of hydrocarbon oil with a flash point of 420° F.



### COTTON IN DUTCH BORNEO.

A specimen of cotton grown in Borneo was recently submitted for examination to the Director of the Industrial and Commercial College at Enschede, Holland, who reported that it appeared to be equal in fineness and length of fibre to the finer qualities of Egyptian cotton. The length of the fibre was about 1½ ins., and the sample was valued at 4s. per pound. It is the product of a tree on the banks of the Barito River, known to the natives as "Kapas-rampit." When fully developed it attains a height of 13 ft. and a circumference of from 15 to 16 ins. According to the natives it lives about seven or eight years. The tree does not occur in the wild state, but is occasionally cultivated as a curiosity by the natives. Formerly, when each native household wove its own cotton, the annual variety of cotton was frequently planted, but the product of this is inferior, the fibre being much shorter than that of "Kapas-rampit," and its cultivation has, therefore, been abandoned. Although the "Kapas-rampit" grows vigorously in several districts of Borneo, its systematic cultivation has not so far been attempted. No information could be obtained concerning the yield of cotton, but trees were noticed, which were covered with flowers or were quite white with the ripe pods. The flowers are of a yellowish-white color, the pods are cylindrical in shape, and triocular, each division containing about eight seeds. The tree grows readily in an argillaceous soil containing a little sand, and is not adversely affected by excess of moisture, which is an important consideration in Borneo, where the climate is humid.

Specimens of the leaves and pods sent to Holland were found to somewhat resemble those of "Kapas-borsaar" (*Gossypium vitifolium*), a species cultivated in Java. Four or five years ago, large plantations of a variety of "Kapas-rampit" were made near Singapore, but were not profitable, since the cotton fibre produced was brittle, and could not be spun. The variety cultivated at Singapore, however, appears to have been different from that found in Borneo. The experimental cultivation of the plant has recently been commenced at Boento.



### GERMAN COLONIAL COTTON.

The British Board of Trade has received the following additional information from the Commercial Attache to H.M. Embassy in Berlin regarding cultivation of cotton in the German colonies. In German East Africa there is now an inspection office at Dar-es-Salaam charged with the organization of all cotton undertakings. Mr. Becker, of Hockley, in Texas, an experienced cotton grower, has been entrusted with this work, and especially with the supervision of the attempts being made to grow cotton in the coast districts, and of the efforts to open new cotton-growing lands on the Tanga Muhesa (Mombo) Railway, on the route of the projected Dar-es-Salaam-Mrogoro (and Kilwa) Railway, in the country towards the Lake Nyassa, in the territories bordering on the Rusidyi River, and in the country in the neighborhood of the Uganda Railway. According to the latest information, the cotton growing on the coasts is progressing well; and the crop, this year, is estimated at 50,000 German lbs. There are newly planted lands in the following Communes: 250 hectares in Dar-es-Salaam, 120 in Kilwa, 20 in Mohorro, and 100 in Bagamoyo (by the Catholic Mission). The cotton, lately received from the districts of Lindi and Tanga, are valued at 70 to 80 marks per 100 lbs. This cotton, said to be equal to the best 'white Egyptian,' is suitable both for the production of yarns for stockings and for fine spinning. In Togoland a system of inspection has been established at Lome, and the cultivation of cotton by the natives is on increase. The crop from the 'Hinterland' is estimated at several hundred bales. The latest consignments of Togoland cotton have been classed higher than the products of the first crop, and are now considered as 'fully good middling.' It is said the Government intend to have the Lome-Palime Railway carried out, and when it is finished to hand it over, together with the landing stage and the coast railway, Lome-Klein Popo, to one single company, under certain conditions. Large samples of cotton received from South-west Africa, grown from 'Sea Island' seed are considered very good by interested persons. In order to assist in the extension of the cultivation of cotton, the farmers want a company to be started to utilize the Swakop River by the construction of dams. There is also a question of starting cotton growing in the north of the Protectorate with irrigation from the Cunene River. The German textile industry and the Chambers of Commerce are reported to be keenly supporting such undertakings."



### WOOLEN MANUFACTURING IN NOVA SCOTIA.

A writer in the Textile World Record gives the following account of the conditions prevailing in the woollen industry in Nova Scotia:

The farmers go in for mixed farming, and generally keep from six to twelve sheep. The wool is of various qualities. The Leicester is a favorite breed, as it is hardy, and gives a

heavy carcass and fleece. The Southdown generally sickens with a severe cold in its sixth year, though this should not weigh with the farmer, as a sheep should not be kept so long anyway, the meat and fleece both deteriorating as the sheep gets old. Probably the extra weight of the Leicester means more food consumed; it is a bony sheep, and the mutton is inferior to that of the short wool variety. I think the farmer is making a mistake in growing Leicesters and cross-bred sheep.

When the wool is sheared, the farmer's family turn to and wash it. This is done in tubs, probably those used for the family washing. It is usually fairly well done, but as the particular method employed depends on the idiosyncracies of the farmer's wife, the results vary considerably. The wool is tied in sheets, counterpanes, or anything that comes handy, and taken to the nearest mill, where it is sold or exchanged for cloth. If no mill is within reach, it is exchanged at the general store for groceries, dry goods, or anything else required.

The manufacturers meet yearly and settle the price to be paid for wool for the ensuing year. This is now 16 cents; if they take cloth instead of cash they are paid at the rate of 20 cents per pound for the wool. When the wool is very inferior, the farmer is generally allowed the usual price for the wool, but charged extra for the cloth. The farmer brings in from 60 to 120 lbs. of wool each season, the storekeepers sell in larger quantities, some of them can send in as much as ten tons at a time. The price is the same as to the farmer, and the mill pays the carriage in most cases.

Unwashed wool is rarely seen, as the price is two-thirds of that paid for tub-washed wool. The farmer does not count the loss in weight in scouring, and thinks that he is being robbed, whereas he would be better off if he sold it greasy, as, in addition to the extra weight, he would save soap, fuel and labor. I never saw any unwashed wool while there, so cannot form any opinion as to the percentage of loss.

The wool is not sorted, except for fine yarn and single for twist. The worst locks will be picked out as the wool is being thrown into the dyetub, and some may be taken out in feeding the mixing picker, but this is all that will be done for most of the stuff. The wool is dyed without any washing other than that given it by the farmer's wife. The result is that uneven dyeing is the rule, not the exception. This is of little consequence in the chevriots they make, as almost all the yarns used are mixtures, and the customers are not at all particular about the pieces matching the samples or each other.

Most of the yarn used is about 1½ run; the wool being coarse and open does not need much carding, and the yarn is generally even, having been carded really more than is necessary in passing through three ordinary cards. It has to be well twisted for warp, and is then a very good yarn of its class. As far as I have been able to learn, none of the mills use a burr picker, and this, combined with the gummy state of some of the wool from bad washing, makes it very difficult to keep the card clothing in good order.

The most used yarn is the 1½ run; then comes the 2½ run single for twist. With the exception of a few summer cloths, the ends and picks vary between 26 and 32, and the same price is paid for weaving; 28 by 28, 66 inches wide in the loom, is a favorite set, though there is a variation both ways in different mills. Designing is mostly on old lines: 1 black, 1 gray, in both warp and weft; 2 black, 2 gray or fancy, wefted black or as warped; 4 black, 4 gray, wefted same or black; 4 black, 4 gray, 2 black, 2 grey, wefted same; and similar simple designs. Black with grey, brown or bronze or green mixtures are popular shades. These made 22 oz. will fetch

\$1.10, if the fancy yarn is a twist, the weight is about 24 ounces per yard, and the price is \$1.25. A favorite cloth with the farmers is made 1 white and brown twist, 1 white and yellow twist, wefted as warped. This makes a dirty looking color that can be dragged across a farm yard without it showing bad stains. A variety of shades are made in this cloth, green and bronze mixtures being used with white in the twist yarns. This cloth will weigh 26 to 27 ounces, and will sell for \$1.35 per 6¼ yard. If with black weft, the weight will be about 24 ounces, and the price \$1.25 per 6¼ yard.

The coarse wool that has been picked out is spun to about 1 run, and is used as weft on a black cotton warp, and sells freely for lumbermen's pants. It is woven with a 4-harness herringbone. This will weigh about 19 ounces, and sells for 70 cents. These figures are quoted 6¼ width, but most of the stuff is made ¾ width, as the trade, and especially the farmers, prefer it, because they can cut the narrower pieces on the kitchen table, whereas 6¼ goods must be spread on the floor.

The designs mentioned sell year after year, so but little designing is done. For the summer season, a few homespuns and wool crashes are made in some of the mills, also some ladies' stuff, but most of the trade is on the same patterns and fabric all the year round.

It must be understood that the Nova Scotia wool will not spin to 3 run, so that it is usual to use 2½ run for twist, making a yarn equivalent to 1¾ to use with the single 1½; thus the cloths made with the same pitch with twist yarns will weigh more and fetch a higher price. Wages in Nova Scotia are low; \$20 a month is a fair wage for learners and well grown lads, while for \$1.25 a day you can obtain a millman, warper, or loom fixer. Foremen get around \$2 a day. As can readily be seen from these figures, there is a handsome profit on woolen manufacturing in Nova Scotia; the smallness of the trade is the factor that prevents a large extension of the industry there. The present rapid increase in the population will, however, count for much in the near future.

\* \* \*

### THE METRIC SYSTEM.

The following letter appeared in the Canadian Engineer for January:

Sir,—I have read the letter on this subject, signed by F. A. Halsey, which appears in your issue for the current month and beg to offer a few comments thereon. Mr. Halsey commences by saying that there is no foundation in fact for the statement that the Metric System has been adopted by forty-four countries.

Now it is no use meeting assertion by contradiction, but I would suggest that Mr. Halsey should send a consignment of goods to any civilized country, excepting Great Britain and dependencies, Russia and Denmark, and he will find that the custom house of any country he may select will insist on his papers being in terms of the Metric System.

Admitting that the use of the Metric System has not as yet, in countries which have recently adopted it, permeated the whole of the interior commerce, your readers will quickly appreciate the argument that, for all purposes of international trade it involves the use of the system by consignors to that country, if it be officially adopted and required by the customs houses.

It is not a fact that in France and Germany there are

used old units, side by side with those of the Metric System. There do exist old names—or nicknames—for some of the present units, but it would be just as true to say that we have two coins here of the value of 6d. because it is sometimes called a "Tanner" as to assert that the "Livre" as a definite weight is still used in France. It is a nickname sometimes applied to half a kilogram.

There are so few opponents of the proposed adoption of the Metric System in this country that it is really, helpful to the movement aimed at by my Association to find such an advocacy as that of Mr. Halsey, but he makes a great mistake when he says that the strength of the movement lies with the scientific men. This Association was organized under the auspices of the London Chamber of Commerce, and is supported (as you will see by the enclosed list), by thirty chambers in all parts of the British Empire. It includes among its subscribers, the following well-known manufacturing and mercantile firms:

Sir W. G. Armstrong Whitworth & Co., Limited, Atkin Bros., Sheffield; Babcock & Wilcox, Limited, The Central Marine Engine Works, West Hartlepool; J. Bibby & Sons Liverpool; Bovril, Limited; Thomas Briggs, Limited, Manchester; British Mannesmann Tube Co., Limited; Brown & Polson; Brunner, Mond & Co., Limited; Cadbury Bros., Limited; Clayton, Son & Co., Limited, Hunslet, Leeds; Clayton & Shuttleworth; David Colville & Sons, Motherwell; J. & J. Colman, Norwich; Jos. Crossfield & Sons, Limited, Warrington; Debenham & Freebody; The Messrs. Denny, Dumbarton; Fraser & Chalmers, Limited; R. A. Hadfield & Co., Sheffield; Harrod's Stores; Hobson, Houghton & Co., Sheffield; G. B. Hunter, Wallsend-on-Tyne; Ipswich Engineering Society; Dr. Jaeger's Sanitary Woolen System; Jonas & Colver, Sheffield; Kayser, Ellison & Co., Sheffield; The Lancashire Explosives Co., Limited; Manfield & Sons, Northampton; The Salford Iron Works; Mappin Bros.; Sir Hiram Maxim; North British Locomotive Co.; A. & F. Peers, Limited; Ransom, Sims & Jeffries, Ipswich; Rudge-Whitworth, Coventry; Rushton, Proctor & Co., Lincoln; The Salt Union, Siemens Bros & Co.; The Tyne Iron Shipbuilding Co.; Vickers, Son & Maxim. Moreover, it has been for a long time supported by retail trade associations, and by the trade unions and lately by several town and county councils.

I am not an engineer, so must not attempt to deal too fully with the screw thread difficulty, but I may perhaps be allowed to say that I was present at a debate on this subject before the members of the Institute of Electrical Engineers, when Alexander Siemens, C.E., produced four screws, two made on a lathe with a metric lead (a 4 m.m. leading screw), and two made on a bench with an eighth of an inch leading screw. With these he produced two nuts. The nut for the 4 m.m. pitch was made with a French tap, and the nut for the two screws of the eighth of an inch pitch was made with an English tap. No one was able to tell Mr. Siemens which of the two screws were made on the m.m. pitch and which on the other. From this example I concluded that there was not much in the screw thread objection.

As Mr. Halsey concludes his letter by reciting the names of some opposing organizations in the States, I may perhaps be allowed to quote the following passage from the Annual Report of the Secretary of the Treasury of the United States for the year ending June 30th, 1903:

#### INTERNATIONAL METRIC SYSTEM.

"During the year the attention of this Department has been forcibly called to the growing need for international uni-

formity in so fundamental a necessity as weights and measures. The Customs Congress of American Republics, held at New York, strongly urged the adoption of the metric system to simplify the transaction of Government business in connection with international trade. Moreover, the National Board of Trade of the United States, the Board of Trade of Canada, and the Congress of Chambers of Commerce of the British Empire have recently urged by strong resolutions the adoption of the metric system. The experience of forty countries of the world has proved beyond question that the international metric system is unsurpassed for practical convenience.

The United States Metric Bill, which Mr. Halsey, in a note, states did not become law, has again been introduced into Congress and has been referred to the Committee on Coinage, Weights and Measures at Washington.

Whether there be a desire for the change in the United States or not, the question is receiving a constantly increasing amount of support throughout the British Empire, and there is every prospect that legislation which will secure our object, will be passed next session of Parliament.

To take a self-interested view of the matter, it would be better for us if the United States did not follow our lead in this matter, for it would leave us in a position much better able to compete with her in supplying goods to those countries, where the Metric Weights and Measures prevail.

E. JOHNSON,

Secretary, Decimal Association, London, Eng.

\* \* \*

—Information received by the Journal of Fabrics from a correspondent in South Africa, goes to show that the trade outlook there is very poor for 1904. Last year crops were generally a failure from the drought, and industries in the towns in any way dependent on the mining industry, are stagnant, owing to the shortage of native labor, which prevents the mines from operating to their full capacity. The sheep farming and angora goat industries have not recovered from the devastation of the war. The exports of Cape Colony in wool for the nine months ending September last were £1,252,000, or about the same as for the nine months of 1902. Shipments of angora hair in the nine months of 1903 were £456,000, against £510,000 for the like period of 1902, while hides and skins and ostrich feathers also declined.

**WANTED.**—To Lease or Buy A SMALL WOOLEN MILL, of One or Two Sets, in Ontario. Plant must be Equipped for Making Yarn, and in good condition. One having a Water Power preferred. — Address, "F. S. J.," care Canadian Journal of Fabrics, Montreal.

## FOR SALE.

For Sale by Tender: Carpet Factory fully equipped for Ingrain Carpets, Art Squares and Smyrna Rugs. Latest up-to-date machinery lately installed, known as The Empire Carpet Co.'s, in the Town of Dundas, County of Wentworth. Address all tenders to

J. F. MORLEY, Dundas, Ont.

The highest or any tender not necessarily accepted.

R. C. WILSON, Dundas,

P. G. QUINN "

GEO. REID & CO., Toronto,  
Inspectors.

# C. E. RILEY & CO'Y.

281-285 Congress Street, Boston, Mass.

Builders and Importers of  
**COTTON, WOOLEN, WORSTED MACHINERY**

**CARD CLOTHING, EMERY FILLET, EGYPTIAN COTTON,  
SPINDLES, FLYERS, FLUTED AND SHELL ROLLS, GRINDING ROLLS, &c.**

Sole Agents for  
**Hamilton Cotton Co.'s**  
Beam Warps, Mule  
Ropes and Spindle-  
Bandings.

**Samuel Law & Sons**  
H. & T. Steel English  
Card Clothing.

**Francis Willey & Co.**  
Bradford, Eng.  
Wools, Tops, Noils.

English Leather  
Belting.

## GEORGE REID & COMPANY, WOOL

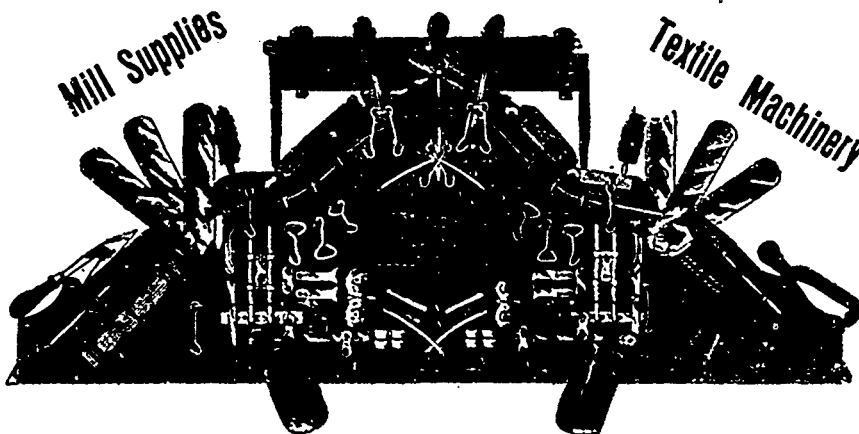

J. Smith  
**Woolen Machinery Co.**  
PHILADELPHIA.  
Carding, Spinning,  
Pickering Machinery.

**Crompton & Knowles**  
Loom Works.

Looms for weaving  
every description of  
Fabric.

**Prince, Smith & Son**  
KRICHLEY, ENG.  
Worsted Spinning  
Machinery.

Office—11 & 13 Front E.  
Warerooms—138 Esplanade E.  
(Foot of Jarvis St.)

### TORONTO

Telephone, Main 3591  
Night call, North 2561

G. THOMPSON.

J. S. MITCHELL.

## THOMPSON & CO.

SHERBROOKE, QUEBEC.

Manufacturers of

# Bobbins and Spools

OF EVERY DESCRIPTION

For Woolen, Cotton and Rope Mills. Extra facilities for  
supplying new mills and filling large orders.

Correspondence Solicited.

Orders Promptly Filled.

The storehouse of the Brussels woolen mills, and quantities of wool and blankets stored therein, were destroyed by fire on January 14th. The building and contents were insured.

In consequence of a statement by the United States Consul, at Kingston, Ont., that binder twine, labelled 600 feet, actually running 450 to 500 feet per pound is being exported from Canada, the United States customs authorities have ordered that binder twine imported into the United States, which does not contain 600 feet to the pound, shall be seized and be subject to forfeiture or the penalties prescribed by statute.

THE NEW

## French Shoddy Picker Machine

SUPERIOR TO ALL OTHERS.

High Test Awarded at Paris Exposition, 1900.

OF SILK, WOOL, COTTON, WASTE, JUTE, etc., it will produce fifty per cent. more production than the Garnett Machine on one-half the power.—Has no rival on the market.

### Toronto Woollen Machinery Company

118 DUKE STREET, TORONTO.

L. BREDANNAZ, Manager.

Sole Agents for Canada and the United States.

Prices on Application.

Prices on Application

**DETERMINING SIZE OF YARNS.**

In reply to a correspondent, we may say that a simple and accurate method of ascertaining the size of woolen yarn is to multiply the yards of single yarn by  $\frac{1}{4}$ , and divide by weight in grains; the answer will be runs. Example: Say 20 yards weigh 25 grains:  $20 \times \frac{1}{4} \div 25 = 3.5$  runs. For the further information of those interested: 3.5 runs = 10's in worsted and 15's in worsted = 10's in cotton. From these figures any calculation of sizes in woolen, worsted and cotton can readily be made.

**BRITISH WOOL AND TEXTILE MARKETS.**

(CORRESPONDENCE OF CANADIAN JOURNAL OF FABRICS.)

The holiday feeling, which made itself felt pretty early in December, lasted well over Christmas, and it was not until the New Year that business here really resumed its ordinary routine. Even now work is not over brisk in the Bradford woolen districts, for manufacturers here are crippled by the scarcity and dearth of warp, whilst the shoddy and mungo manufacturers in consequence, though well supplied with orders, find it impossible to get particulars for delivery.

The slump in prices which set in with the opening of the London sales at the end of November, and affected Bradford during nearly the whole of December, quickly evaporated with the resumption of business after the holidays. Not only has the fall-off in prices been fully regained, but the market all round is considerably stronger in tone to-day than it was before the slump. Low wools, especially, are keenly sought after, and the market is completely cleared of anything below 36's. In fact, material of all grades is extremely scarce and this suffices to maintain full rates, although the actual amount of business done is a minimum. Top makers, even those who still hold stocks of wool, can-

not for the most part be induced to make quotations until they find how things go next week in London, and the few who will do so ask such fancy prices that buyers are scared off. The yarn trade is slack, particularly the export branch.

Mohairs remain steady at low figures, whilst a small sale of low wools, mainly Persians, Chinas and camel-hairs, which took place in London during the early part of this week, provoked very little competition and established no change in rates.

Bradford, January 20th, 1904.

**CHEMICALS AND DYESTUFFS.**

We have to report an improvement in trade; orders are coming in better. Prices remain firm. Advances in some lines. Bluestone has advanced  $\frac{1}{2}$ c. per lb. Soda ash scarce, and higher prices expected for spring.

Bleaching powder .....	\$ 1 60 to \$ 1 80
Bicarb. soda .....	1 75 to 2 00
Sal. soda .....	0 80 to 1 00
Carbolic acid, 1 lb. bottles .....	0 35 to 0 40
Caustic soda, 60° .....	2 10 to 2 25
Caustic soda, 70° .....	2 35 to 2 50
Chlorate of potash .....	0 09 to 0 10
Alum .....	1 35 to 1 50
Copperas .....	0 65 to 0 75
Sulphur flour .....	1 60 to 1 70
Sulphur rock .....	1 75 to 1 80
Sulphate of copper .....	0 06 to 0 06½
White sugar of lead .....	0 07 to 0 08
Sumac, Sicily, per ton .....	57 50 to 58 00
Bich. potash .....	0 7½ to 0 08½
Soda ash, 487° to 587° .....	1 25 to 1 35
Chip logwood .....	1 50 to 1 75
Castor oil .....	0 07 to 0 08
Cocoonut oil .....	0 07 to 0 08

**NEW BLACK FOR WOOL**

**EMPIRE BLACK**

**Absolutely Fast ONE DIP Black**

Unequaled for depth of shade. Users of black should investigate.  
Fastest Black on the market.

**F. E. ATTEAUX AND CO.**  
**BOSTON.**

CANADIAN BRANCHES:

41 Colborne Street,  
TORONTO

13 Lemoine Street,  
MONTREAL

**A. KLIPSTEIN & CO.**

122 PEARL STREET, NEW YORK.  
HAMILTON, Ont., 24 Catherine Street, N. MONTREAL, Que., 17 Lemoine Street

**Chemicals and Dyestuffs.**

**CARBIDE BLACK E**

**Cheapest and Best One Dip Black on the Market**

HEADQUARTERS FOR

- |                         |                       |
|-------------------------|-----------------------|
| Caustic Potash 90%      | Carbonate of Potash   |
| Chlorate of Potash      | Bleaching Powder      |
| Phosphate of Soda       | Refined Cutch A K.C.  |
| Yellow Prussiate Potash | Yellow Prussiate Soda |

BRANCHES—

BOSTON—287-28 Congress St. PHILADELPHIA—623 N. Front St.  
CHICAGO—156 Kinzie St. PROVIDENCE—13 Mathewson St.

**Sole Agents for the Society of Chemical Industry, Basle, Switzerland.**

**POLLACK BROTHERS & CO.,**

Canadian Sales Dept. for

**H. A. METZ & CO., NEW YORK.**

Sole Agents for the products of FARBWERKE VORM. MEISTER LUCIUS & BRUENING, HEGHST o/ MAIN.

**Anilines, Alizarines, Synthetic Indigo, Etc.**

**55 ST. FRANCOIS XAVIER ST., MONTREAL.**

---

---

# FIRE PROTECTION.

---

**FIRE HOSE—  
Cotton—Rubber Lined.**

**FIRE HOSE—  
Linen—Unlined.**

Full Stock constantly on hand.

---

**HIGH GRADE  
“GENUINE OAK”  
(ENGLISH TANNED)**

**LEATHER BELTING**

No Shoulders, Necks or Bellies.

---

**ENGLISH CARD CLOTHING**

Full Stock on Hand.

*QUALITY UNEXCELLED.*

---

**D. K. McLAREN,**

132 Bay Street, Toronto.

751 Craig Street, Montreal.

**WOOL MARKETS.**

Montreal.—Market firm at recent quotations. There is very little business being done. London sales closed at lower figures than the highest of the series. The knitting mills are all very busy, but the cloth or tweed industries have very few orders ahead. Prices: Greasy Cape, 17 to 19½c.; B.A., 30 to 40c.; Ontario washed fleece, 17 to 18c.; and unwashed, 13 to 14c.; but very little of the last mentioned offering, having been all marketed. Nova Scotia washed fleece, 22 to 24½c.; Nor'-West, 15 to 16½c.

Toronto.—In fleece there is very little offering now. Stocks in the country have been pretty well cleaned up. There is an enquiry for export to the United States, but so far no sales are reported, bids being no higher than some time ago. There is a fair demand for pulled wools from the home mills now, and the market is steady. The following are the latest quotations: Fleece, combing, 17½ to 18c.; clothing, 19c.; unwashed, coarse, 10c.; unwashed, fine, 11c., pulled, super, 19 to 21c., extra, 22 to 24c. On February 10th, C. M. Henderson & Co. sold by auction at the warehouse of E. T. Carter, Toronto, 15,500 pounds of scoured crossbred wool, which was purchased in one lot at 21 cents.

**WOOL SALES.**

The first series of Colonial wool sales opened in London on January 19th, and closed on February 1st. The following figures show the total stock offered and the corresponding amounts for 1903:

	Total Stock for sales of Jan. 19, 1904. Bales.	Total Stock for sales of Jan. 20, 1903. Bales.
Sydney .....	25,000	27,000
Queensland .....	12,000	10,500
Port Philip .....	24,000	24,000
Adelaide .....	13,500	12,400
Tasmanian .....	500	100
Swan River .....	14,000	16,000
Cape .....	9,000	12,000
New Zealand .....	39,000	38,000
Falklands, Puntas and River Plate	2,000	2,000
<b>Total .....</b>	<b>139,000</b>	<b>142,000</b>
Merino wool .....	89,000	90,000
Crossbred wool .....	50,000	52,000

Australian scoured merinos, during the series, ruled very firm, and advanced 5 per cent.; greasies were unchanged. Inferior and heavy Australian were somewhat easier. On the other hand, good light descriptions ruled in sellers' favor. Fine crossbreds barely maintained the December level. Medium crossbreds opened 5 to 7½ per cent, and cross-

breeds 10 per cent. higher. They declined partially during the second half of the series, and closed with medium 5 per cent. higher, and coarse 7½ to 10 per cent. up. Cape of Good Hope and Natal long greasy was unchanged; fine short was dearer; and scoureds showed a gain of ½d. During the sales 66,000 bales were taken by home buyers; 60,000 were sold to the Continent, and 5,000 to America. The balance was held over for the second series.

The following were the highest and lowest prices obtained during the series: New South Wales, scoured, 11¼d. to 1s. 11d.; greasy, 5¾. to 1s. 1d. Queensland, scoured, 10d. to 2s.; greasy, 6¾d. to 1s. ½d. Victoria, scoured, 7½d. to 2s. 1d.; greasy, 4¾d. to 1s. 3¾d. South Australia, scoured, 1s. 2d. to 1s. 7d.; greasy, 5d. to 1s. West Australia, scoured, 1s. 5½d. to 1s. 6¾d.; greasy, 5d. to 1s. ½d. Tasmania, greasy, 9d. to 1s. ½d. New Zealand, scoured, 6d. to 1s. 5¾d.; greasy, 4¾d. to 1s. ¾d. Cape of Good Hope and Natal, scoured, 9d. to 1s. 9d.; greasy, 5¾ d. to 10¼d.

**REASONS WHY**

**The Canadian Oliver Typewriter**

IS SUPERIOR TO

**ALL OTHERS**



**VISIBLE WRITING.**—The writing is visible, each letter being in plain sight the instant it is made.

**DOUBLE TYPE-BAR.**—It has a double or U-shaped Type-Bar provided with a shaft bearing as broad as the bar is long, thus insuring Permanent Alignment without guides.

**SPEED.**—Its visible writing, rapid escapement, direct type-bar connection, downward stroke, and light touch, make it the most speedy of all writing machines.

**TYPE, FACE UPWARD FOR CLEANING.**—The type are of steel and lie face upward so that they can be cleaned with one sweep of the ordinary type brush.

**PRICE.**—\$30.00 cheaper than imported machines of like standard; because MADE IN CANADA.

**Why Pay Duty?**

LINO TYPE COMPANY, - - MONTREAL  
MANUFACTURERS

**Branch: 55 VICTORIA STREET,  
TORONTO.**

**GEIGY ANILINE and EXTRACT COMPANY**

104 and 106 Murray Street, - NEW YORK.

BOSTON. PROVIDENCE. PHILADELPHIA. ATLANTA. CHICAGO. TORONTO.

**Aniline Colors, Calico Printers' Specialties.**

Dyewood and Sumac Extracts.

Synthetic Indigo J. B. G.



**EVAN ARTHUR LEIGH**

232 Summer Street, Boston, Mass., U.S.A.

IMPORTER OF

**Textile MACHINERY**  
Etc.

Sole Agent for the U. S. and Canada for

**Messrs. PLATT BROS. & CO.**  
(LIMITED), OF OLDHAM, ENGLAND.

BY FAR THE LARGEST MAKERS OF TEXTILE MACHINERY IN THE WORLD

Platt's Cotton, Woolen and Worsted Machinery.  
Sole makers of Brown's Patent Carding Rollers for Wool—give woolen yarn a worsted appearance.  
Platt's Special Machinery for making English & French Worsted Yarns  
Platt's Special Machinery for making Cotton Waste into Yarns.

Also Sole Agent for U. S. and Canada for

**Messrs. MATHER & PLATT**

Salford Iron Works, Manchester, England.

Bleaching, Dyeing and Finishing Machinery and Archbutt-Deeley System of Softening and Purifying Hard Water.  
*The Best System on the Market.*

Wool Washing and Drying Machines. Garnett Machines. French and English Napping Machines. Sykes's Card Clothing for Cotton. Critchley's Card Clothing for Woolen and Worsted. Valey's Fallers. Harding's Pins and Circles. Dronsfield's Grinders and Emery Fillet. Comber Aprons, Condenser Aprons, etc.

**Textile Machinery Association, Limited,**

Flax, Hemp and Jute Machinery.

**George Hodgson, Limited,**

Bradford, Looms for Worsteds, etc.

**The Automatic Feeding Machine Company,**

Feeders for Fibres of all classes.

**HYDRO-EXTRACTORS**

FOR-

**WOOL, COTTON, WORSTED  
AND ALL OTHER  
TEXTILE TRADES**

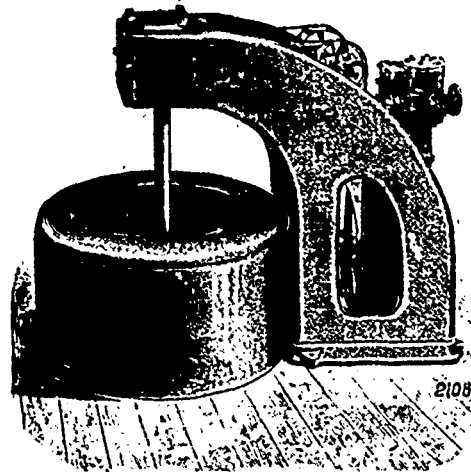

48 in. Engine Driven Suspended Hydro Extractor.

**WATSON, LAIDLAW & CO.**

DUNDAS STREET. GLASGOW. SCOTLAND.

SEND FOR OUR 1904 CATALOGUE.

**William Whiteley & Sons, Ltd.**

LOCKWOOD, HUDDERSFIELD, ENGLAND

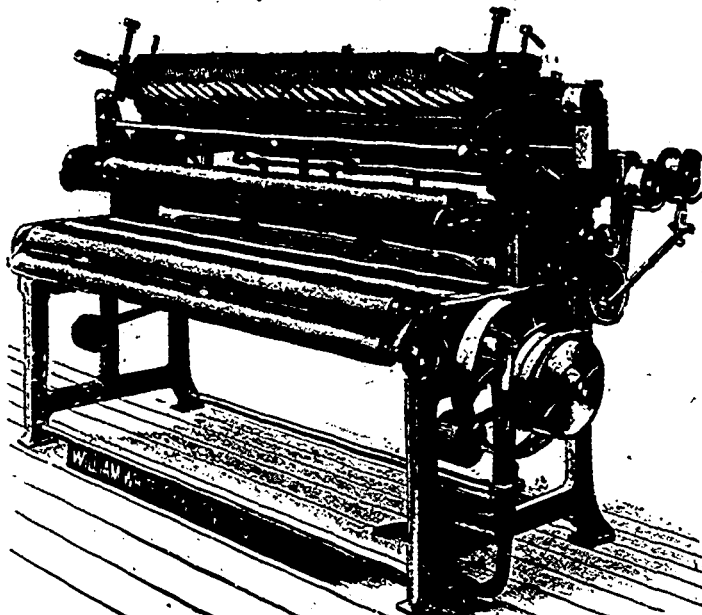

Complete Cloth Finishing Plants  
Tentering and Drying Machines  
Wool and Cotton Drying Machines  
Improved Self Acting Mules  
Winding, Warping and Sizing Machines  
and other Woolen Machinery

Mercerizing Machinery. Complete Plant for Aniline Black.  
CATALOGUE ON APPLICATION.

WILLIAM FIRTH,  
President.

EDWIN BARNES,  
Vice-President.

JOHN H. NELSON,  
Treasurer.

**WILLIAM FIRTH COMPANY**

67 Equitable Bldg., - 150 Devonshire St., BOSTON, Mass.

SOLE IMPORTERS OF

ASA LEES & CO., Limited, Textile Machinery of every description for Cotton, Woolen and Worsted.

SOLE AGENTS FOR

JOSEPH STUBBS, Gassing, Winding and Reeling Machinery for Cotton, Worsted and Silk.

GEO. HATTERSLEY & SONS, Ltd., Makers of every description of Looms, &c.

JAMES MACKIE & SONS, Ltd., Makers of Flax, Tow, Hemp and Jute Preparing and Spinning Machinery.

GEO. ORME & CO.'S Patent Hank Indicators, &c.

JAMES YATES & SON, Hardened and Tempered Steel Card Clothing for Woolen and Worsted Cards.

LOCKETT, CROSSLAND & CO., Engravers and Builders of Leather Embossing Machinery, &c

R. CENTNER FILS., Heddles.

GOODBRAND & CO., Yarn Testing Machinery, Wrap Reels, &c.

JOSHUA KERSHAW & SON, Roller Skins, &c.

GEORGE SMITH, Doffer Combs, &c.

BRADFORD STEEL PIN CO., Comber Pins. [&c.

CLAPHAM, SMITH & CO., Caps, Tubes and Spindles for Worsted, ALSO AGENTS FOR

JOSEPH SYKES BROS., Hardened and Tempered Steel Card Clothing for Cotton.

WILLIAM TATHAM & CO., Waste Machinery.

DRONSFIELD BROS., Limited, Emery Wheel Grinders, Emery Fillet and Flat Grinding Machines.

COTTON CORD & VELVET CUTTING MACHINE CO., Corduroy Cutting Machines, &c.

Pick Glasses, Leather Aprons, Patent Wire Chain Aprons.

**The Manual of Lubrication,**

Or, How to Choose and How to Use Lubricants for any description of Machinery

With Methods of Determining the Purity and other Properties of Oils, etc

By LOUIS SIMPSON

Price \$1.00  
Post-paid

Address **BIGGAR-SAMUEL, Limited,**  
Fraser Bldg., MONTREAL, Can.

## Hamilton Cotton Co., Hamilton

MANUFACTURERS OF

White and Colored Yarns, Single or Double, Hosiery Yarns of all descriptions, Warps, Twines, white or colored. Webbing & Bindings in great variety, Lampwicks, etc.

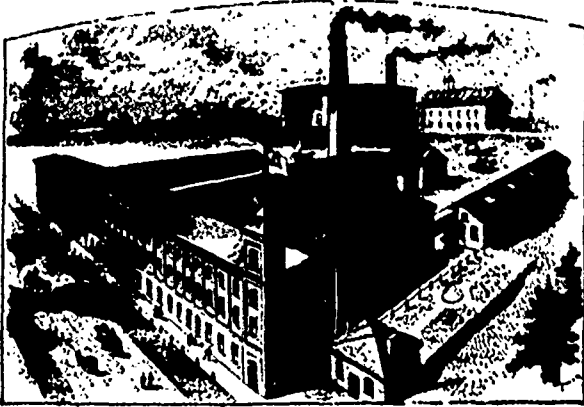

SELLING AGENTS

WM. B. STEWART, 18 Front St. East, Toronto.

Agent for Warps: GEO. REID, 11 & 13 Front St. E. TORONTO.

# Labels

FOR EVERY  
PURPOSE  
AND  
EMBOSSED  
PRINTED  
ENGRAVED

LEVY & Co., 19 Leader Lane, TORONTO

## Canada Bobbin Company,

WALKERTON, Ont.

Successors to  
KIR & HARCOURT.



Established  
1857.

### Largest Makers of Bobbins in Canada.

MANUFACTURERS OF ALL KINDS OF

## Spools and Bobbins

Used in Woolen, Cotton, Silk, Rope and  
Wire Mills, and Small Wood Turnery.

Having lately enlarged and improved our plant, and having a large quantity of well-seasoned stock in the rough always on hand, we are prepared to fill any order carefully and promptly.

## STEVENS RIFLE TELESCOPES

ALL interested in rifle telescopes should not fail to see our new catalog, devoted exclusively to this department of our manufacture. It will be found full of practical information on rifle telescopes, with descriptions and illustrations of many new devices. We intend to make our telescope department the most complete of its kind in the world, and this catalog will show our progress in that direction. These telescopes can be fitted to any make of rifles. Mailed free upon request.

**WE ALSO MANUFACTURE RIFLES, PISTOLS, SHOTGUNS.**

J. STEVENS ARMS & TOOL CO., 124 Main St., Chicopee Falls, Mass. U.S.A.

## LUCIEN MARCAN'S Successors BRADFORD (England.)

Exporters of Wool Tops, Noils, Rags, Shoddies, Silk, Mohair, Camel Hair Noils, and all Specialties in Raw Materials required by Cloth, Hosiery, Blanket, Carpet and Felt Manufacturers.

An enquiry will cost you two cents and two minutes' time. If you will favor us with the same we shall be glad to send you samples of any raw material which you may require—quoted at lowest prices delivered at your station, duty and other charges paid.

CABLES—"LUCIEN, BRADFORD."

CODES—A. B. C. 4th and 5th Editions and Private Code.

The Waterloo Woolen Mill was obliged to close down on January 27th, owing to the snow blockade on the rail-ways cutting off the coal supply.

Hartley and Chowen, inventors of the warping reel attachment, referred to last month, have decided to leave Peterboro for the United States, where they will manufacture their invention, after having been assured that it will be adopted generally by the weaving mills in that country. They will probably locate in Lowell, Mass.

The Ontario Blanket Co.'s mill, in Clarksburg, Ont., has installed a new boiler and carried out other repairs. This mill has been very busy during the past year, having had to run day and night till recently to keep up with orders.

**E. T. CARTER**

Successor to JOHN HALLAM

35 years at the old stand:  
83 & 85 Front Street East  
**WOOL**  
DOMESTIC AND FOREIGN WOOLS  
**TORONTO**

**LONG & BISBY**

DEALERS IN  
Foreign and Domestic  
**WOOL AND COTTON**  
GENERAL COMMISSION MERCHANTS  
**HAMILTON, ONT.**

**JOHN E. BROWN,**

Foreign and Domestic

**WOOL**

77 McHab Street N.,  
**HAMILTON, ONT.**

**The R. Forbes Co.**

(Limited)  
Manufacturers of

**WOOLEN AND WORSTED YARNS**

For Hosiery and other work

**HESPELER, ONT.**

**INDEX TO ADVERTISEMENTS**

Atteaux & Co., F. E.....	4
Barlow, John W. ....	10
Bellhouse, Dillon & Co.....	1
Benson & Co., W. T.....	1
Bischoff & Co., C.....	2
Brown, John E.....	9
Canada Bobbin Co.....	8
Cantlie, James A.....	10
Carter, E. T.....	9
Cassella Color Co.....	1
Crabb & Co., William....	10
Crowe W. M.....	2
Dominion Dyewood & Chemical Co....	1
" Guarantee Co.....	10
" Oil Cloth Co.....	10
Dronsfield Bros.....	13
Eickhoff, A.....	9
Felten & Guillaume.....	14
Firth Co., William.....	7
Forbes Co., The R.....	9
Fraser, Robt. S.....	2, 18
Garland Mfg. Co.....	9
Geigy Aniline & Extract Co.....	6
Gessner, David.....	13
Halton's Sons, Thomas.....	2
Hamilton Cotton Co.....	8
Jack & Co., Watson.....	1
Klipstein & Co., A.....	4
Lachute Shuttle Co.....	9
Lawson & Sons, Samuel.....	14
Leigh, Evan Arthur.....	7
Leitch, A. W.....	1
Levy & Co.....	8
Linotype Co.....	6
Long & Bisby.....	9
Marcan's Successors, Lucien.....	8
Mather & Platt.....	7
McArthur, Corneille & Co.....	7
McLaren, D. K.....	5
" Belting Co., J. C.....	14
Mississippi Iron Works.....	9
Montreal Blanket Co.....	9
Morrice, Sons & Co., D.....	12
Morton, Phillips & Co.....	9
New York & Boston Dyewood Co.....	1

Philadelphia Textile Machinery Co.....	7
Pollock Bros. & C.....	4
Reiche & Co.....	10
Reid & Co., George.....	8
Riley & Co., C. E.....	3
Roessler & Hasslacher Chemical Co....	2
Rosamond Woolen Co.....	10
Sheldon & Sheldon.....	2
Smith Woolstock Co.....	10
Stevens Arms & Tool Co.....	8
Stoddard, Haserick, Richards & Co.....	12
Thompson & Co.....	8
Toronto Woolen Machinery Co.....	3
Turnbull Co., The C.....	10
Want Advertisements.....	4
Watson, Laidlaw & Co.....	7
Watson Mfg. Co., L. S.....	14
Whiteley & Sons, Limited, William....	7
Wilson Bros.....	11
" Bobbin Co.....	18
" Paterson & Co.....	1
Young Bros.....	9

Established 1848.

**A. EICKHOFF**

(A. KRAMEK, Proprietor)

Manufacturer and Dealer in

Hatters', Furriers', Tailors',  
Glovers' and Shirt Cutters'  
**KNIVES AND SCISSORS.**

Knives for all kinds of business always on hand and warranted. All kinds of Cutlery ground and repaired.

No. 381 BROOME STREET,  
Between Broadway and Bowery,  
**NEW YORK CITY**

**Matte's, Hughes' and  
Robinsonian  
Interest Tables**

**Buchan's, Oates' and  
Robinsonian  
Sterling Exchange Tables**

Tables in French and  
German Exchange.

Send for Catalogue.

**MORTON, PHILLIPS & CO.**

Stationers, Blank Book Makers  
and Printers

1755-1757 Notre Dame St., Montreal

**WILSON BROS.**

**Wool Importers**

38 Front Street East, - Toronto.

E. A. WOOLS and CARBONIZED  
NOILS a specialty.

**The Lachute Shuttle Company**

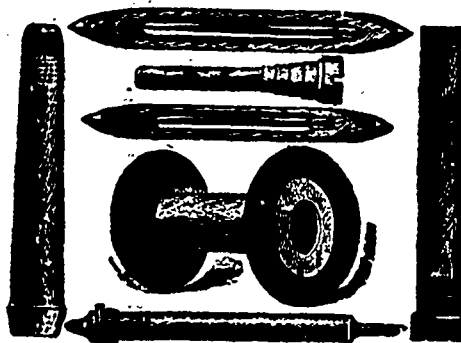

We are the largest Shuttle  
Manufacturers in Canada.

Slubbing, Roving and all kinds  
of Bobbins and Spools for  
Cotton and Woolen Mills.

We have always on hand  
a large stock of  
Thoroughly Seasoned  
Lumber.

Orders solicited and all work guar-  
anteed to give satisfaction.

**E. F. AYERS, Manager**  
**LACHUTE, P.Q.**

**MISSISSIPPI IRON WORKS**

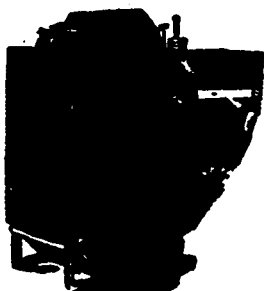

ESTABLISHED  
1875.

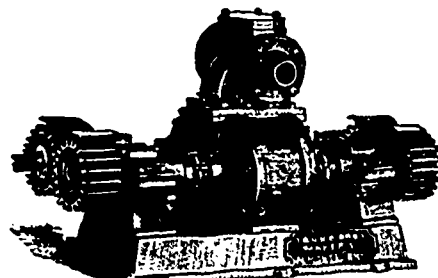

Manufacturers of English or American Pulling Mills and Washers, Wool Pickers,  
Exhaust Fans, Drives, Dusters, Etc., any Force Pumps for Fire Duty, Miller Feed  
Pumps, Shafts, Hangers, Castings, Rollers, Gearing, Forging.  
Equipment of MILLS of every kind.  
**YOUNG BROS.,** Almonte, Ont.

ESTABLISHED 1859

**THE C. TURNBULL CO.,**

OF GALT, Limited.

Full Fashioned Lamb's Wool Underclothing, Hosiery and  
Knitting Yarns, Perfect Fitting Ladies' Ribbed Vests,  
Sweaters, Jerseys, Knickers.

**"WE HOLD THEE SAFE."****The Dominion  
Guarantee Co.**

LIMITED.

Head Office, Montreal, Can.

CAPITAL, \$200,000.

Insurance against burglary and housebreaking. Policies clear  
and free from vexatious or restrictive clauses.

CHAS. W. HAQAR, General Manager

**ROSAMOND WOOLEN CO.**

ALMONTE, ONT.

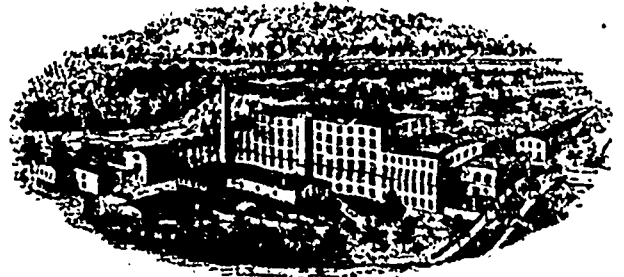

Fine **TWEEDS, CASSIMERES, and Fancy WORSTED  
SUITINGS AND TROUSERINGS**

Colors warranted as fast as the best British  
or Foreign Goods.

**Dominion Oil Cloth Co'y**

MANUFACTURERS OF

Limited

**Oil-  
Cloths**

of every description

Floor Oil-Cloth, Table Oil-Cloth, Carriage  
Oil-Cloth, Enamelled Oil-Cloth,  
Stair Oil-Cloth, etc.

Office and Works:

Corner St. Catherine and Parthenais  
Sts., MONTREAL, QUE.

**SMITH WOOLSTOCK CO**Manufacturers of Wool Stock and  
Shoddies of every description.

Specialty: Dyeing and matching of colors for the Woolen  
Mill trade a specialty.

Office and Works:

219 FRONT STREET EAST, TORONTO

**RAILWAY ENGINEERING.**By Cecil B. Smith, M.A., E.

A concise Treatise on Railway Construc-  
tion, etc. for Engineers and Students.

Cloth. 200 Pages.

Profusely Illustrated. - \$1.50.

**Biggar-Samuel, Limited, Publishers**  
Toronto and Montreal.

You are interested in the  
**Metric System**

Of Weights and Measures,  
because it will soon be adopted  
in Canada.

CHART 10 cts. PER COPY.

**BIGGAR-SAMUEL LIMITED,**  
18 Court Street, TORONTO

TO WOOLEN MANUFACTURERS.

**MESSRS. REICHE & CO.**

Wool, Tops, Noils, Yarns, etc.

BRADFORD, ENGLAND.

Represented in  
Canada by **JAMES A. GANTLIE,**  
22 St. John Street, Montreal.

Samples and Lowest Quotations promptly supplied.  
Correspondence solicited.

**THE MONTREAL BLANKET CO.**

Manufacturers of

**Shoddies, Wool Extracts  
and Upholstering Flocks**

Office and Works: COTE ST. PAUL  
P.O. Address: MONTREAL

**If You** WISH to learn something  
about the Metric System of  
Weights and Measures, write for a copy of  
the Metric Chart, 40 x 14 inches, mailed on  
receipt of ten cents in stamps or coin.

Address **BIGGAR-SAMUEL, Limited,**  
Toronto or Montreal.

**AGENTS WANTED.**

Local agents wanted to take subscriptions  
for an Engineering Publication. For terms  
apply, Box B,

Office of Canadian Engineer,  
62 Church Street,  
Toronto, Ont.

**WILLIAM CRABB & CO.**

Manufacturers of all kinds of

**Hackle, Gill, Comb and Card Pins, Picker Teeth, Needle****Pointed Card Clothing in Wood and Leather for****Flax, Jute, Tow, etc.**

Hackles, Gills and Wool Combs made and repaired; also Rope Makers' Pins, Picker Pins, Specia  
Springs, Loom and Shuttle Springs, English Cast-Steel Wire, Cotton Banding and General Mill Furnishings.  
Bloomfield Avenue and Morris Canal, NEWARK, N. J.

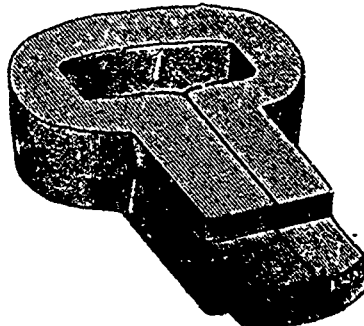
**JOHN W. BARLOW**

Manufacturer of

**LOOM PICKERS,**

LAWRENCE, MASS.

This out represents Barlow's Pat. Bow Picker  
with solid interlocking foot. Pat. Feb. 26, 1889.

# CONTENTS OF JANUARY NUMBER.

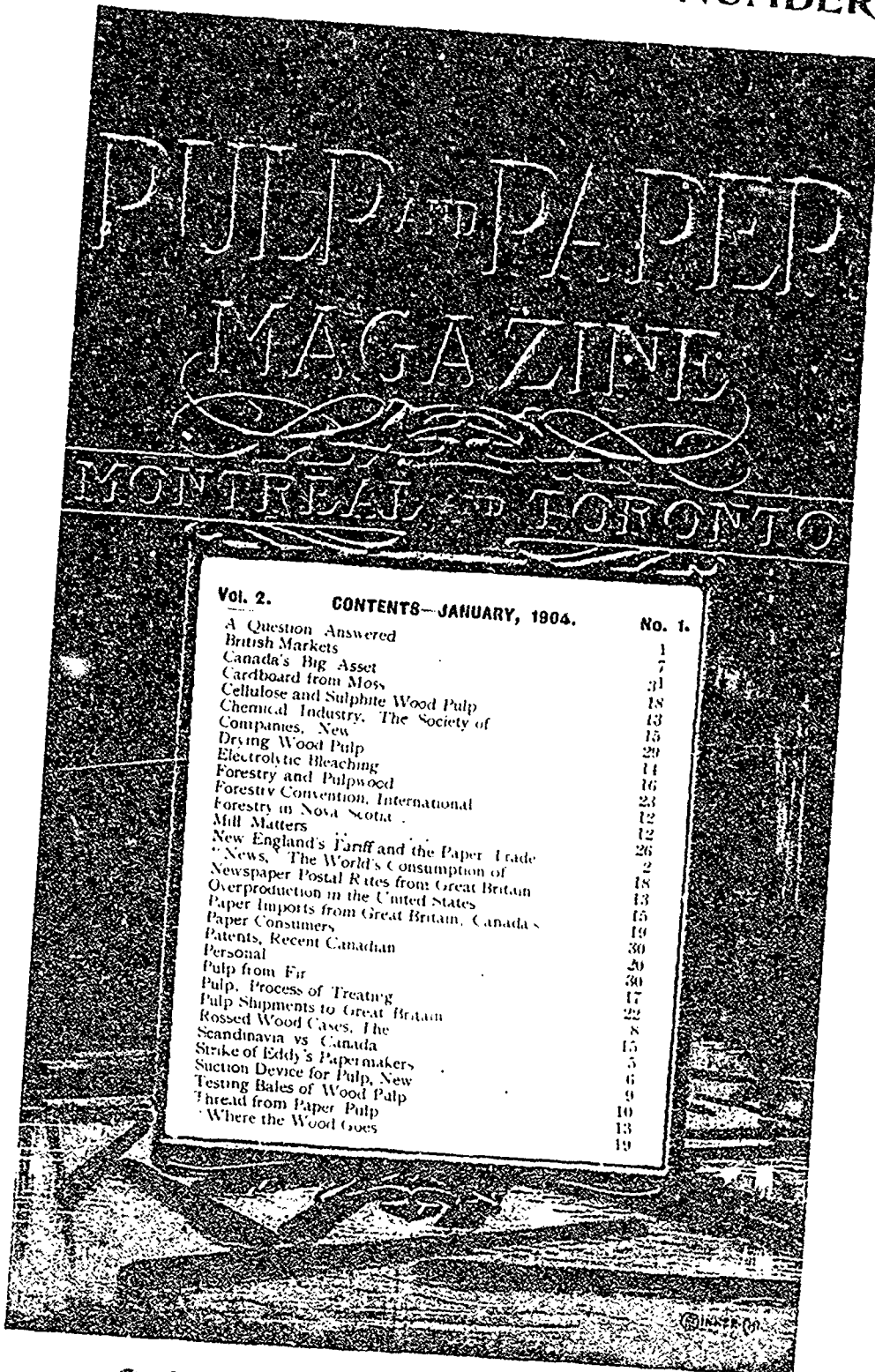

**Subscription \$1.00 a year.**

If interested write the publishers.

**BIGGAR-SAMUEL, Limited,**

8 Court Street, TORONTO

or

Fraser Building, MONTREAL

# STODDARD

**IMPORTERS OF COTTON, SILK,  
WORSTED, WOOLEN AND FIBRE  
MACHINERY, MILL SUPPLIES,  
EGYPTIAN COTTON AND BURLAPS**

**Sole American Representatives for  
DORSON & BARLOW, LTD.**

New Hopper Bale Breakers, Pickers, Cards, Combers, Fly Frames, Mules, Gassers, etc. Improved Worsted Carding Engines.

**FRINGE, SMITH & SON**

Gill Boxes, Noble Combs, Drawing, Roving, Spinning, Twisting and Reeling Machinery for Worsted.

# HASERICK

**TAYLOR, WORDSWORTH & CO.**

Wool Washers, Noble Combs, Back Washers, Carding Engines, Cone Drawing for Carpet Stock.

**SAMUEL LAW & SONS, LTD.**

Card Clothing of Every Description.

**WM. WHITELEY & SONS**

Mules, Tenting Machines, Warpens, Mercerizing Machinery, etc.

**E. HOYLE & SONS, LTD.**

Dyeing and Finishing Machinery, Hydraulic Presses.

**HARDING, RICHARDSON, RHODES & CO., LTD.**

Gill and Combing Pins, Needles.

**SAMUEL ROWBOTTOM**

Spindle Bands and Tapes.

# RICHARDS

**JOHN DIXON & SONS**

Mill Bobbins.

**J. PARKINSON**

Loom Templates.

**J. KAYE & SONS, LTD.**

Patent Oil Cans.

**J. WHITE & SONS**

Apron & Picker Leather.

**SOCIETE ALSACIENNE de CONSTRUCTIONS**

**MECANIQUES de MULHOUSE**

Alsatian Cotton Combers, Slashers for Fine Warps, French System of Worsted Spinning.

**MILL SUPPLIES** German Tempered Steel Wire Heddles, Persian Role Skins, Worsted Doup Twine, etc.

# & CO.

**152-8 Congress St.,  
8 Currer St.  
Philadelphia Office,**

**Boston  
Bradford, Eng.  
Bourse Bldg.**

## BINDER TWINE COMPANIES.

About 150 shareholders attended the annual meeting of Brandon Binder Twine Company on January 22nd, Professor Wolverton, president, in the chair. The annual report showed that the company had made 810,800 lbs. of twine, had sold 675,515 lbs., and had earned during the past year a profit of \$2,570.42. Considerable discussion was entered into as to the best methods of fighting American competition, and the question of raising of funds to carry on the year's business was discussed. At the end of the meeting over \$4,000 worth of stock was subscribed for and votes of thanks were passed for the president, manager and other officials. The directors for 1904 are: Prof. Wolverton, president; F. W. Smith, A. Leslie, A. McPhail, E. L. Christie, J. T. Part-ridge, W. T. Johnston, J. G. Burk and H. A. Fraser. The outlook for the present year is distinctly encouraging, and the directors anticipate an increased output.

The Walkerton Binder Twine Company, Walkerton, Ont., have issued their report for 1903. There will be no dividend this year on the paid-up capital stock of \$115,150. The official auditor reports a loss on the business of the company of \$4,560.75. After paying a dividend, writing off sundry ledger accounts and part of promotion account, and allowing for depreciation of plant, the net assets have been reduced from \$20,121.26, to \$1,304.49. The auditor adds that amongst "the assets is included the sum of \$7,083.68, a balance of promotion account. This is an asset of no actual cash value, and should, by this time, have disappeared entirely from the assets. We have reason to believe, too, that a very considerable percentage of the open ledger accounts and bills receivable, included in the assets, will be found uncollectible." The output was not half that of the previous year.

## COTTON COMPANY MEETINGS.

The annual general meeting of the shareholders of the Merchants Cotton Company was held in Montreal on February 9th, when the following board of directors was elected: R. B. Angus, A. A. Ayer, John Beattie, J. P. Cleghorn, James Crathern, Jonathan Hodgson, the Hon. Robert Mackay. The statement of business presented for the past year showed that while the mills had worked at three-quarters of their full capacity, earnings did not warrant the payment of a dividend. At a subsequent meeting of the new board James Crathern was elected president, the Hon. Robert Mackay vice-president, and W. S. Barker secretary-treasurer.

The annual general meeting of the shareholders of the Montreal Cotton Company was held on February 10th, at which the following gentlemen were present: A. E. Adams, F. D. Adams, Henry Fry, L. H. Gault, A. H. Gault, Hill Campbell, Geo. Caverhill, J. P. Cleghorn, E. H. Copeland, James Crathern, R. F. Cream, Selkirk Cross, John Dillon, J. O. Gravel, E. K. Greene, George A. Greene, F. W. Kelley, A. Kingman, Fred Lacey, W. S. Leslie, D. A. Lewis, E. Lichtenheim, Peter Lyall, John McFarlane, Hon. Donald McMillen, A. B. Mole, J. T. Molson, H. M. Molson, N. Papineau, D. F. Smith, George Smith, J. G. Snetsinger, R. R. Stevenson, S. W. Stevenson, James Wilson, Hon. J. K. Ward. The annual reports were submitted and were found satisfactory. The following gentlemen were elected directors for the ensuing year: Mr. S. H. Ewing, Mr. H. M. Molson, Mr. Jacques Grenier, Hon. J. K. Ward, Mr. Hamilton Gault, Mr. R. R. Stevenson, Mr. James Rodger, Mr. James Wilson. At a subsequent meeting of the directors, Mr. S. H. Ewing was elected president and Mr. James Wilson, vice-president.

Established 1823.

41 Highest Awards.

# Wilson Brothers Bobbin Co., Limited

Telegrams "Wilson, Cornholme"  
A.B.C. and A1 Codes used.

## BOBBINS & SHUTTLES

POSTAL ADDRESS:

Cornholme Mills, Garston, Liverpool.

OFFICE:

14 Market Place, Manchester.

The best results in  
**Card Grinding**  
are obtained by using  **ATLAS** TRADE-MARK.

**DRONSFIELDS' PATENT**  
**GROOVED EMERY FILLETING**  
SPECIALITIES: MACHINES FOR GRINDING CARDS  
MACHINES FOR COVERING ROLLERS WITH LEATHER

**DRONSFIELD BROS. LTD.**  
Atlas Works, OLDHAM, ENGLAND.

COUNTY C'

### TEXTILE MACHINERY (New and Second Hand)

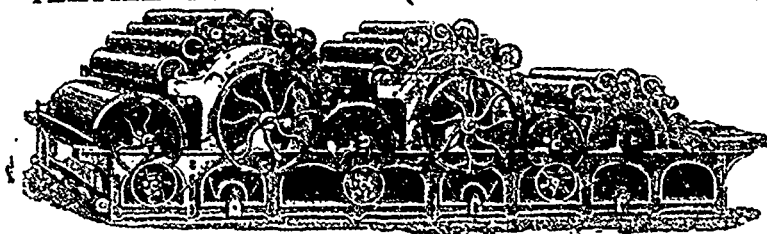

English Sales Attended.

### CARD CLOTHING TETLOW'S

Stock in Canada

### Condenser Aprons

Buffed Surfaces  
Plain & Grooved

Oak-Tanned and White Belting  
Cotton Banding, Rim Spindle and Braided  
Shuttles, Pickers, Heddles, Harness  
Patent Frames, GENERAL FURNISHINGS

ROBT. S. FRASER

17 LEMOINE ST., MONTREAL

### THE LATEST

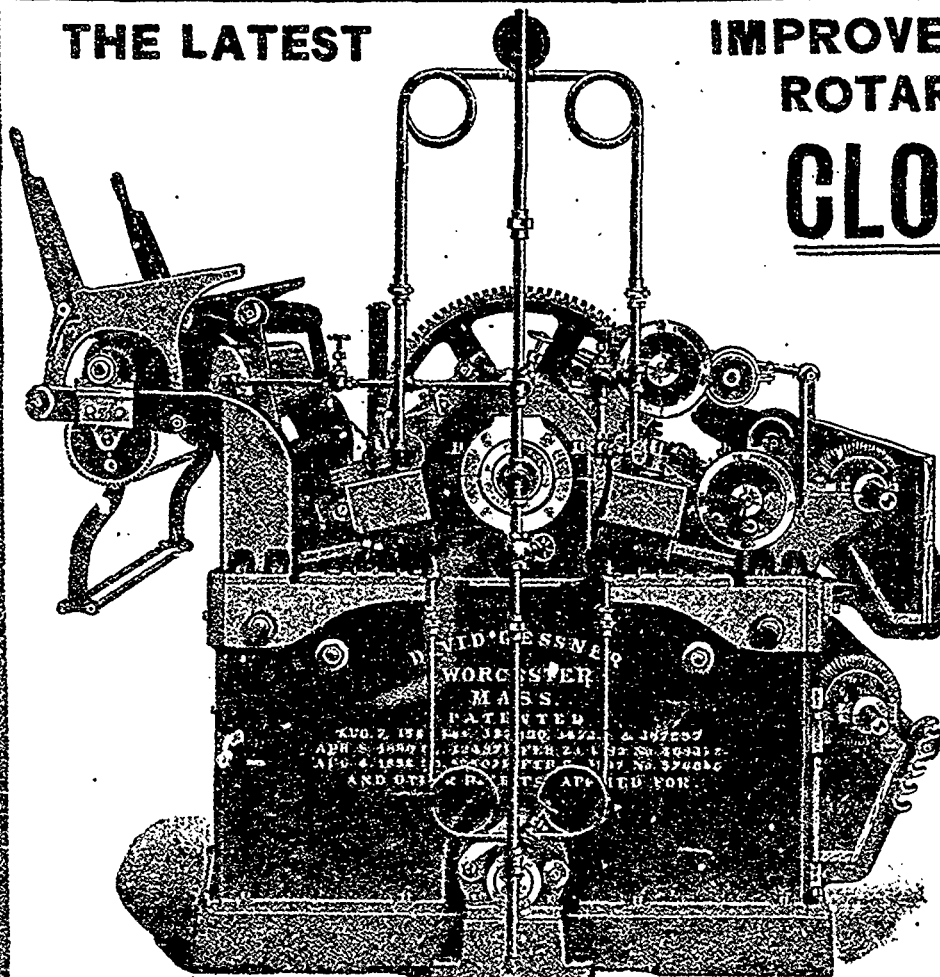

### IMPROVED DOUBLE-BED ROTARY

# CLOTH PRESS

The bed plates are self-adjusting, the levers that operate them being mounted upon sliding steel fulcrum bars within the frames. The trussing apparatus of the bed plates is so arranged as to permit not only a forcing of the centres of the bed plates in a forward direction, toward the cylinder, but also away from it, which is of the utmost importance if the bed plates should ever become sprung. Bed plates and cylinder after being cold finished, are ground absolutely true while heated by steam at 75 lbs. pressure, insuring perfectly straight and uniform pressing surfaces. Pressure is applied and removed instantaneously, and by power.

**DAVID GESSNER,**  
WORCESTER,  
MASS., U.S.A.



*The Workman's Friend—a Reliable Belt.*

USE

OUR "EXTRA" BRAND



Factory  
MONTREAL

{ THE J. C. McLAREN BELTING CO., }

TORONTO  
VANCOUVER

# Fairbairn Lawson Combe Barbour, Ltd.

## LAWSON BRANCH

Hope Foundry.

LEEDS.

England.

Makers of Machinery for

**Preparing and Spinning Flax, Hemp, Tow and Jute**

AND OF Special Machinery for the Manufacture of Twines,

—ALSO OF—

**GOOD'S COMBINED HACKLING AND SPREADING MACHINE,**

Long Reach Screw-Gill Drawing Frames, — Chain-Gill Drawing Frames with Apron Head,

**PATENT HIGH-SPEED HORIZONTAL AND AUTOMATIC SPINNING FRAMES FOR MANILLA,**

AND OTHER

SPECIAL MACHINERY FOR THE MANUFACTURE OF ROPE YARNS AND BINDER TWINE.

**Improved Laying Machines. Haskell-Dawes Tubing Twisters**  
Brownell's Patent Twisting and Laying Machines for Twine.

—Complete Plans and Estimates for Flax, Tow, Hemp and Jute Mills, Trawl-Twine-Factories and Steam Ropeworks.—

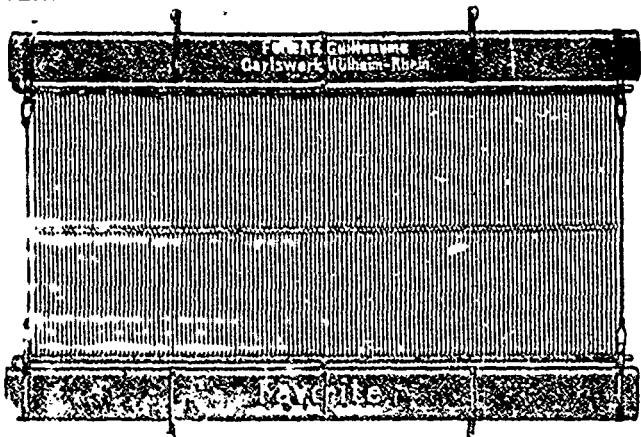

*Fellen & Guilleaume, Carlswerk*  
*Actien-Gesellschaft, Mulheim-on-Rhine*

Manufacturers of

**Tinned Cast Steel Wire Heddles**

made on Patent Automatic Machines and consequently perfectly uniform in every respect. The Lightest, Exactest and most Uniform Wire Heddles ever made not surpassed by any other Wire Heddles in the market

Patent "Favorite" Shafts for Weaving

ever combined with above Heddles the best most Reliable and most Durable Frames, either made with one or two carrying wires inside the wooden frame. These shafts have already been adopted by a great number of weavers who speak most favorably of them, as can be seen from many testimonials in the possession of the makers. For Prices apply to

L. S. WATSON MANUFACTURING CO., Leicester, Mass.

## L. S. WATSON MANUFACTURING CO. LEICESTER, MASS.

Sole Agents for the BEST  
Spinning & Twisting Travelers  
Made by Prouty Wire Co.

Send samples of the Travelers you use and we will send you a sample box to which of our make free of charge.

**Manufacturers of WATSON'S PATENT MACHINE WIRE HEDDLES**

Guaranteed to be perfectly adapted to weaving all kinds of Woolen, Cotton and Worsted Fabrics, Fancy Cotton, etc., etc. Superior Harness Frames furnished promptly. Also Hand Cards of every description.

Also Agents for the SMITHURST Roving and Twisting Gear for all woolen manufacturers and makers of yarns. Write us for particulars.