

Technical and Bibliographic Notes / Notes techniques et bibliographiques

The Institute has attempted to obtain the best original copy available for filming. Features of this copy which may be bibliographically unique, which may alter any of the images in the reproduction, or which may significantly change the usual method of filming, are checked below.

L'Institut a microfilmé le meilleur exemplaire qu'il lui a été possible de se procurer. Les détails de cet exemplaire qui sont peut-être uniques du point de vue bibliographique, qui peuvent modifier une image reproduite, ou qui peuvent exiger une modification dans la méthode normale de filmage sont indiqués ci-dessous.

Coloured covers/  
Couverture de couleur

Coloured pages/  
Pages de couleur

Covers damaged/  
Couverture endommagée

Pages damaged/  
Pages endommagées

Covers restored and/or laminated/  
Couverture restaurée et/ou pelliculée

Pages restored and/or laminated/  
Pages restaurées et/ou pelliculées

Cover title missing/  
Le titre de couverture manque

Pages discoloured, stained or foxed/  
Pages décolorées, tachetées ou piquées

Coloured maps/  
Cartes géographiques en couleur

Pages detached/  
Pages détachées

Coloured ink (i.e. other than blue or black)/  
Encre de couleur (i.e. autre que bleue ou noire)

Showthrough/  
Transparence

Coloured plates and/or illustrations/  
Planches et/ou illustrations en couleur

Quality of print varies/  
Qualité inégale de l'impression

Bound with other material/  
Relié avec d'autres documents

Continuous pagination/  
Pagination continue

Tight binding may cause shadows or distortion along interior margin/  
La reliure serrée peut causer de l'ombre ou de la distorsion le long de la marge intérieure

Includes index(es)/  
Comprend un (des) index

Title on header taken from: /  
Le titre de l'en-tête provient:

Blank leaves added during restoration may appear within the text. Whenever possible, these have been omitted from filming/  
Il se peut que certaines pages blanches ajoutées lors d'une restauration apparaissent dans le texte, mais, lorsque cela était possible, ces pages n'ont pas été filmées.

Title page of issue/  
Page de titre de la livraison

Caption of issue/  
Titre de départ de la livraison

Masthead/  
Générique (périodiques) de la livraison

Additional comments: /  
Commentaires supplémentaires:

This item is filmed at the reduction ratio checked below /  
Ce document est filmé au taux de réduction indiqué ci-dessous.

10X	12X	14X	16X	18X	20X	22X	24X	26X	28X	30X	32X
<input type="checkbox"/>	<input type="checkbox"/>	<input type="checkbox"/>	<input type="checkbox"/>	<input type="checkbox"/>	<input type="checkbox"/>	<input type="checkbox"/>	<input type="checkbox"/>	<input type="checkbox"/>	<input checked="" type="checkbox"/>	<input type="checkbox"/>	<input type="checkbox"/>

2/29

Labour Gazette

# The CANADIAN MANUFACTURER

AND INDUSTRIAL WORLD  
DEVOTED TO THE MANUFACTURING INTERESTS OF CANADA.

Vol. 55.

TORONTO, OCTOBER 4, 1907.

No. 7.

## BERTRAM PLANERS

Method of Driving—Belt or Direct Connected Motor.

The Illustration shows our 48 inch x 48 inch New Model Planer arranged with three cutting heads and motor drive.

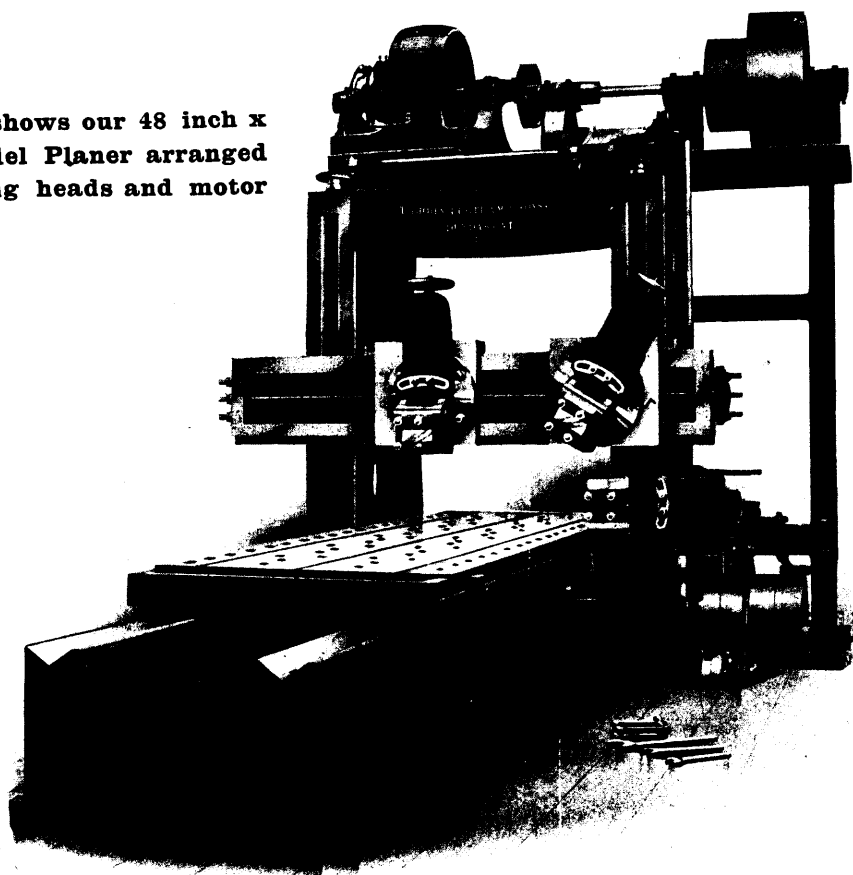

This planer has been designed to meet the new conditions. It has the weight, the power, the speed, and a number of convenient features which have stamped the BERTRAM PLANERS as unique in the machine shop from the Atlantic to the Pacific.

### The John Bertram & Sons Co., Limited

DUNDAS, ONTARIO, CANADA



## "LAURIE" Punching Presses

These Presses range in size from No. 0 to No. 4 and are adapted for nearly all kinds of work, namely, blank cutting, punching, perforating form and binding.

WRITE FOR CATALOGUE TO

### Laurie Engine & Machine Co.,

MONTREAL Limited

Toronto Agents: Parmelee & Nicholson  
Halifax Agents: Gullford & Son

## "IMPERIAL" AIR TOOLS



**We don't say the "Imperial" is the best tool on the market!**

We leave that to our satisfied customers.

Are you one of them?  
Are you satisfied with the tools you are using?  
Send for an "Imp" on 30 days trial.

CHIPPERS, RIVETERS, DRILLS

### CANADIAN RAND COMPANY

LIMITED

MONTREAL, QUE.

TORONTO, HALIFAX, KENORA, ROSSLAND, B.C.

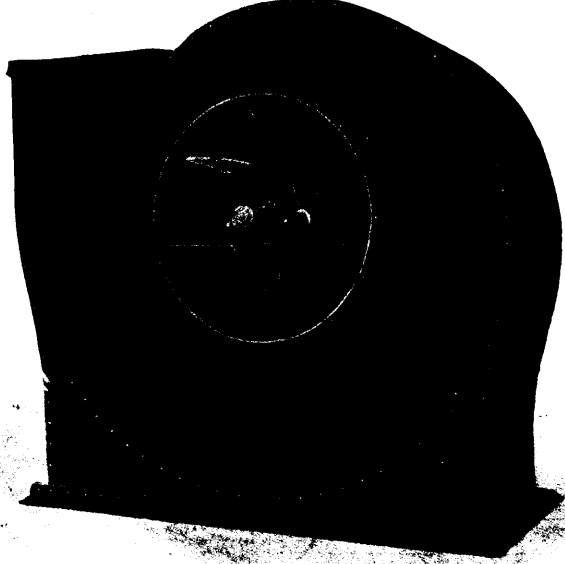

## HOT BLAST HEATING

### MECHANICAL DRAFT

DRYING SYSTEMS OF ALL KINDS  
FOR DRYING ANY MATERIAL

### SHAVINGS EXHAUST SYSTEMS INSTALLED COMPLETE

Dry Kiln Trucks and Wheels, Lumber Dryers,  
Brick Dryers, Steel Brick Cars,  
Transfer Cars, Turntables, Etc.

Stationary and Portable Forges, Cupola Blowers, Exhaust Fans, Planing Mill Exhausters  
Dust and Shavings Collectors, and Steam Specialties, such as Back Pressure  
Valves, Oil Separators, Exhaust Heads, Etc.

### VERTICAL AND HORIZONTAL STEAM ENGINES

## SHELDONS, LIMITED

Engineers and Manufacturers GALT, ONT.

# IDEAL HIGH SPEED ENGINES

PERFECTION IN HIGH SPEED ENGINE DESIGN, NOISELESS RUNNING,

PERFECT  
LUBRICATION

ACCESSIBILITY

ECONOMY

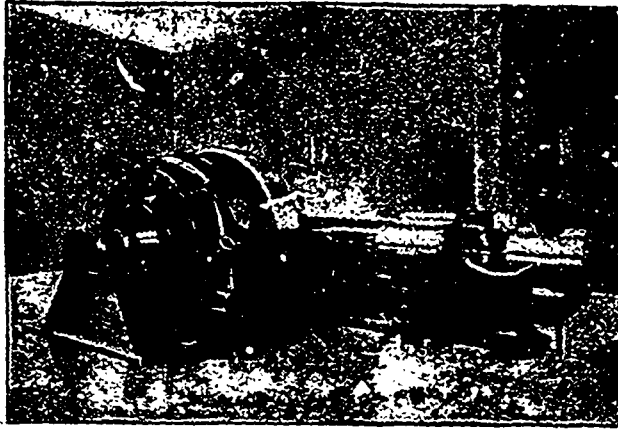

ASK FOR  
BULLETIN No. 6

QUOTATIONS  
CHEERFULLY  
GIVEN

**THE GOLDIE & McCULLOCH CO., LIMITED**  
GALT ———— ONTARIO ———— CANADA

WE MAKE Wheelock Engines, Corliss Engines, Ideal Engines, Boilers, Pumps, Flour Mill Machinery, Oat Meal Mill Machinery, Oat Meal Steam Pan Kilns, Wood Working Machinery, Iron Pullers, Wood Rim Split Pulleys, Shafting, Hangers, Gearing, Friction Clutch Pullers, Friction Clutch Couplings, etc., Safes, Vaults and Vault Doors. Write for Catalogue.

Western Branch: 248 McDermott Ave., Winnipeg, Man.

Quebec Agents: ROSS & GREIG, Montreal, Que.

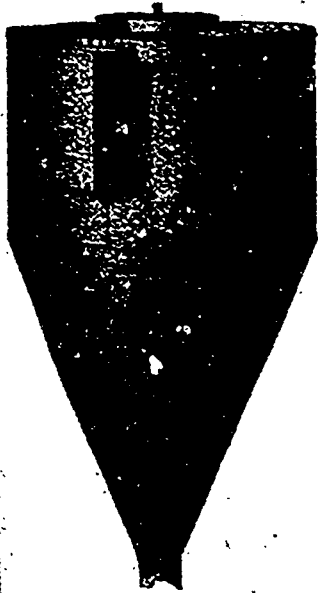

## Shaving Systems

Fans, Separators and Piping Installed.

## Trucks

Steel Roller-Bearing Trucks and Transfers, also Wheels and Bearings for Wood Frame Trucks.

## Moist Air Kilns

Write us for full particulars. We install Force and Natural Draft Kilns of latest design.

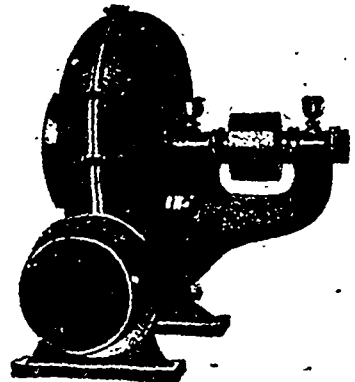

FANS  
CUPOLA FANS  
BLOWERS  
EXHAUSTERS  
BRICK CARS  
TRANSFERS AND  
DRYERS

# Dominion Heating & Ventilating Co., Limited

HESPELER, CANADA.

Successors to McEachren Heating and Ventilating Co.

When writing to Advertiser, kindly mention THE CANADIAN MANUFACTURER.

## THE ALCOMA STEEL CO., Limited

SAULT STE. MARIE, ONT.

is now booking orders for

# STEEL RAILS

For delivery during the Season of 1907.

Parties intending purchasing will find it to their interests to let us have their specifications at an early date so as to ensure desired deliveries.

**DRUMMOND, McOALL & CO.,**

General Sales Agents.

OFFICE:

Canada Life Building, MONTREAL.

## CANADA IRON FURNACE CO., Limited

Montreal, Radnor and Three Rivers

Manufacturers of the well-known

**"C.I.F." Three Rivers  
Charcoal  
Pig Iron**

Suitable for Car Wheels, Cylinders and Fine Castings, where the utmost strength is required.

UNSURPASSED IN STRENGTH BY SWEDISH, RUSSIAN OR AMERICAN CHARCOAL IRON.

Offices: Canada Life Insurance Building, MONTREAL.

## STRUCTURAL IRON WORKERS

Will find our stock of their material most complete, including

Angles  $\frac{1}{2}$ " to 8"

Beams 3" to 24"

Channels  $\frac{1}{2}$ " to 15"

Tees 1" to 5"

U.M. Plates 7x3/16 to 16x1-7/8

Boiler and Structural Rivets.

Large Angles, Beams and Channels cut to any desirable length. Prompt shipments.

See our monthly stock list.

**THE  
BOURNE-FULLER CO.  
IRON, STEEL,  
PIG IRON,  
CORE.**

Cleveland, Ohio.

Pittsburg Office,

1126 Frick Bldg.

# Nova Scotia Steel and Coal Co., Limited

MANUFACTURERS OF

## BRIGHT COMPRESSED STEEL SHAFTING

From  $\frac{3}{8}$  to 5 inches in Diameter. Guaranteed Straight and True to within 1/500 of an Inch.

Spring, Reeled Machinery, Tire, Toe Caulk, Sleigh Shoe, Angles, Special Sections and all Merchant Bar Steel. Sheet Steel up to 48 inches wide.

**RAILWAY AND ELECTRIC RAILWAY CAR AXLES, FISH  
PLATES, SPIKES AND TRACK BOLTS**

Tee Rails, 12, 18, 24 and 28 lbs. per yard.

**HEAVY FORGINGS A SPECIALTY**

"SCOTIA" PIG IRON FOR FOUNDRY USE.

WORKS—TRENTON, N.S., and SYDNEY MINES, N.S.

HEAD OFFICE—NEW GLASGOW, NOVA SCOTIA

# The Hamilton Steel & Iron Co., Limited.

HAMILTON,

CANADA.

## PIG IRON

FOUNDRY

BASIC

MALLEABLE

SEND US YOUR INQUIRIES.

HIGH-GRADE BAR IRON

OPEN HEARTH BAR STEEL

ANGLES,

BANDS,

SPLICE BARS,

WASHERS,

AXLES,

R. R. SPIKES

FORGINGS of Every Description

IN ROUGH OR ROUGH TURNED.

PROMPT DELIVERIES MADE

# FORGINGS

CRANK SHAFTS,

CONNECTING RODS,

PISTON RODS,

LATHE SPINDLES,

SHAFTING, ETC.

FORGINGS OF ANY DESIRED HIGH CARBON FOR  
SPECIAL WORK.

CANADA FORGE CO., LIMITED

WELLAND, ONT.

# NORTHERN ALUMINUM CO., Limited

Shawinigan Falls, P.Q. Business Office Pittsburgh, Pa.

## ALUMINUM

INGOTS - SHEETS - TUBING, ETC.

*Aluminum Stamped, Cast, Spun Articles of any Description to Order.*

**ALUMINUM WIRE and CABLES for ELECTRICAL CONDUCTORS**

**Cold Die-Rolled  
Steel and Iron**

**For Shafting, Piston Rods, Screw  
Steel and Roller Bearing Parts**

**Rounds, Squares  
Flats and Hexagons**

**ASK FOR PRICES**

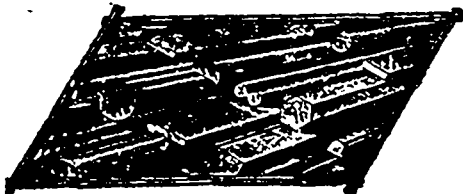

True to Size and Highly Polished.

### Union Drawn Steel Co., Limited

Office and Works, Hamilton, Canada

## JEFFREY LOG HOIST

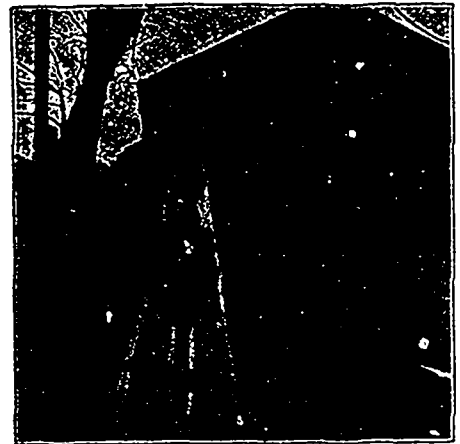

FOR OTHER ILLUSTRATIONS OF

**ELEVATING; CONVEYING, POWER  
TRANSMITTING MACHINERY**

**ASK FOR CATALOGUES 80 AND 57A**

### THE JEFFREY MFG. COMPANY

COLUMBUS, OHIO, U.S.A.

New Canadian Branch—Lagauchetiere and Cote Sts., Montreal, Canada

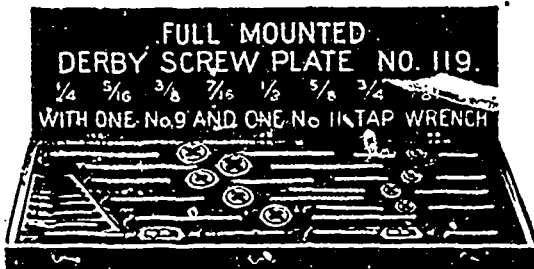

**FULL MOUNTED  
DERBY SCREW PLATE NO. 119.**  
1/4 5/16 3/8 7/16 1/2 5/8 3/4  
WITH ONE No. 9 AND ONE No. 11 TAP WRENCH



WE MANUFACTURE

**STAY BOLT TAPS**, all diameters and lengths up to 94 inches.  
**SPINDLE STAY BOLT TAPS and TAPS for Screw  
Machines, and TAPS for all uses.**

Regular and Full Mounted Reece and Derby Plates, Bicycle  
and Machinists' Plates, etc., etc.

**BUTTERFIELD & CO.,**  
Rock Island, Que.

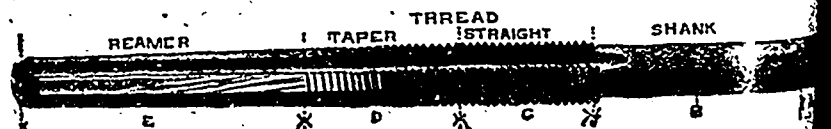

When writing to Advertisers kindly mention THE CANADIAN MANUFACTURER.

# Robb Power Plants

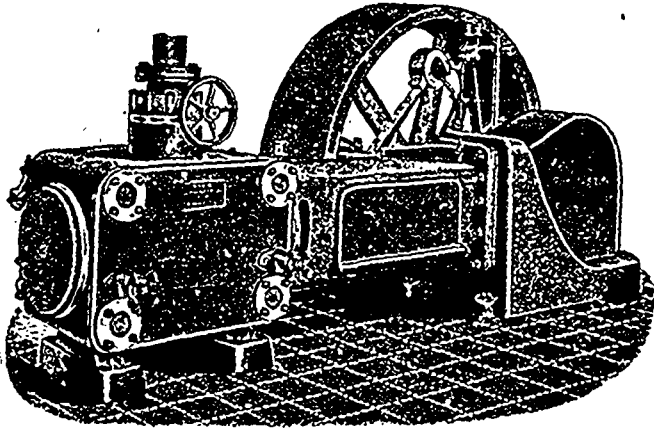

We design and contract for steam power plants and maintain an experienced and thoroughly practical engineering staff that is at the service of our customers.

- Corliss Engines
- High Speed Vertical Engines
- Medium Speed Horizontal Engines
- Robb-Mumford Boilers
- Return Tubular Boilers
- Water Tube Boilers

**ROBB ENGINEERING CO., Limited, AMHERST, N.S.**

DISTRICT OFFICES } 320 Ossington Avenue, Toronto; Wm. McKay, Manager.  
 Bell Telephone Building, Montreal; Watson Jack, Manager.  
 385 Carlton Street, Winnipeg; J. F. Porter, Manager.

# SMALL TOOLS

We are sales agents for the PRATT AND WHITNEY SMALL TOOLS AND GAUGES. These are now made in Canada and are known the world over as the standard for quality and accuracy. Better material. Longer life. Same price.

## FILES

FAIRBANKS' FILES are made of the best SHEFFIELD STEEL and hold their edge while others grow smooth.

## NORTON GRINDING WHEELS

Made of ALUNDUM are the hardest and sharpest known. They don't merely grind, but cut and cut fast. Best results. Longest life.

## YALE AND TOWNE CHAIN BLOCKS

In all sizes from  $\frac{1}{4}$  to 20 tons for quick and easy hoisting.

## MACHINE SHOP SUPPLIES

# CANADIAN FAIRBANKS CO., LIMITED

Toronto

Montreal

Winnipeg

Vancouver



# Brantford Roofing Co., Limited, Brantford, Can.

Manufacturers of High-Grade Ready Roofing

Viz. "Brantford Asphalt"

"Brantford Rubber"

Under this Trade Mark



Specially Adapted for the Roofing of  
Factories, Warehouses, Rinks, and Large  
Buildings of every Description.

Get a "Brantford Specification" for an A-1 Job.  
Write us for Tenders—on Materials Only, or Laid Complete.

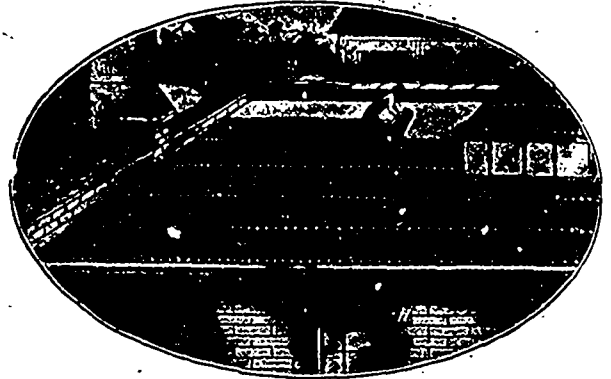

# Albert Manufacturing Co.

MANUFACTURERS OF THE WELL-KNOWN

"Hammer Brand" **Calcined Plaster**

AND

**PATENT ROCK WALL PLASTER.**

HILLSBOROUGH, N.B., CANADA.

# MORISON Suspension Furnaces

For Land and Marine Boilers

With Plain Ends or Flanged to any required shape.

Uniform Thickness, Easily Cleaned, Unexcelled for  
Strength, Unsurpassed for Steaming Capacity.

*The universally satisfactory record of "THE MORISON" proclaims it the best furnace made.*

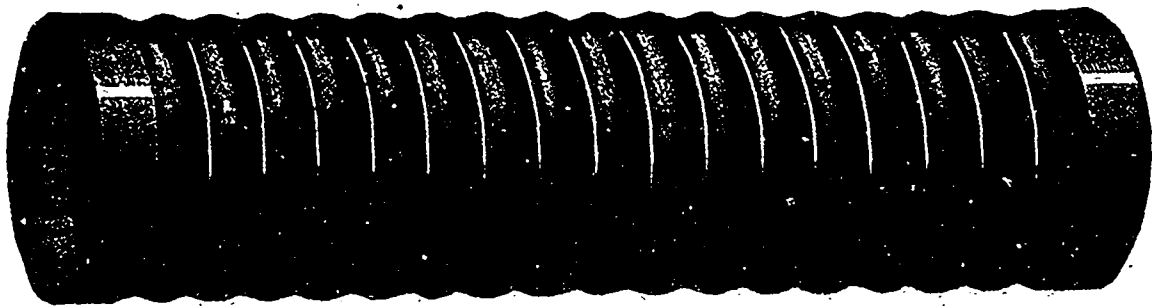

MANUFACTURED BY

**THE CONTINENTAL IRON WORKS,**

WEST AND CALVER STS.,  
BOROUGH OF BROOKLYN,  
Near 10th and 23rd Street Ferries.

**New York**

Sole Canadian Agent—MR. GEORGE HOLLAND, M. C. Soc. C. E., P. O. Box 529, MONTREAL

When writing to Advertisers kindly mention THE CANADIAN MANUFACTURER.

**The A. R. Williams Machinery Co.,** LIMITED MANUFACTURERS IMPORTERS AND DEALERS

TORONTO



OUR NEW-BELL PATENT HIGH SPEED AUTOMATIC ENGINE

—IN—

Engines, Boilers  
Iron Machinery  
Tools  
Wood-Working  
Machinery

—AND—

**GENERAL MILL  
MACHINERY and  
SUPPLIES**

Write for.....

**CATALOGUE and  
QUOTATIONS**

**J. B. HALL**

115½ Simcoe Street, Toronto

**SAFETY STAMPING PRESSES.**

**DIES, TOOLS AND SPECIAL MACHINERY MADE TO ORDER.**

First-class work only. Designs made for machine you may require.

A small advertisement will always serve to keep your name before the buyers who read this paper.

WE HAVE

Ready for Immediate Delivery

**FOUR**

HAND AND FOOT POWER

**SAWING MACHINES**

Fitted with Adjustable Fence and Angle Guage.

The diameter of these saws is 10 inches, the hole 7/8 in. One Rip and one Cross Cut is supplied with each machine. Table is built up of hardwood strips to resist warping.

Power can be used separately or together.

**BARGAINS FOR CASH**

WRITE FOR PRICES.

**Dynamic Machine Works, Limited**

63 and 65 Dalhousie Street, Montreal.

**Standard Bearings**

LIMITED

Niagara Falls, Ont.

Engineers, Toolmakers,  
High - Class Machinists

MANUFACTURERS OF

**Anti-Friction, Roller, Babbitted, Gun  
Metal and other Bearings**

Toronto Office, 94 Canada Life Building, Toronto

President, - - Wm. Bowman  
Managing-Director, - J. Dove-Smith  
Secretary-Treasurer, - J. Frank Adams

Bearings designed for any special purpose, Auto-  
mobile axles, gears, etc.

Estimates given for High-Grade Machine Work.

# THE PETER HAY KNIFE CO., Limited

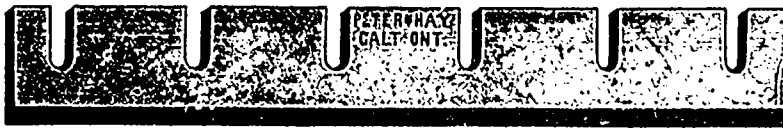

GALT, ONT.

Manufacturers of

## MACHINE KNIVES

For WOOD-WORKING,  
PAPER CUTTING and LEATHER SPLITTING  
MACHINES.

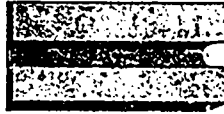

Quality Warranted.

Send for Price List.

SHEAR BLADES,

BARK and RAG KNIVES.

Etc., Etc., Etc.

# HOWDEN'S

Double Acting  
High Speed  
Enclosed Engines  
with forced lubrication for

ELECTRIC LIGHTING, TRACTION, TRANSMISSION of POWER, Etc.

JAMES HOWDEN & CO., Scotland St. Glasgow

Prices and full particulars from **E. DOWIE** Sole Agent for Canada  
223 Commissioners St., Montreal

U.S. BATTLESHIP "NEBRASKA"



THIS BATTLESHIP IS LINED WITH  
SYRACUSE SMELTING WKS. "BABBITT"  
IT IS POSITIVELY THE BEST  
SYRACUSE SMELTING WORKS

Is adapted to all purposes. Has a tensile strength of 10,000 pounds to the square inch. Has no fear of high speed and heavy pressure. One pound of the MANGANESE Brand will cover as much space as one and one-half pounds of any other metal at the same price. Will not chill in the ladle. Will cast true to the mould,

### IMPROVEMENT OF THE AGE

U.S. BATTLESHIP "NEBRASKA"  
is lined throughout with

## SYRACUSE SMELTING WORKS' BABBITT METALS

MANGANESE ANTI-FRICTION BABBITT METAL—"The Best by Test"  
Because of its Malleability, Ductility, Toughness, Hardness,  
Plasticity, Fusibility and Fluidity

free of pinholes. Will not cut or rip the journals.  
Saves oil. Is an assurance against breakdowns or unnecessary delays.  
SAVES TIME, MONEY, LABOR. Is sold under a written guarantee.  
SPECIAL INDUCEMENTS TO JOBBERS.

**SYRACUSE SMELTING WORKS, - Montreal, Que.**

# NICKEL

THE CANADIAN COPPER COMPANY.

# NICKEL FOR NICKEL STEEL

THE ORFORD COPPER COMPANY.

**WRITE US FOR PARTICULARS AND PRICES.**

General Offices: 43 Exchange Place, NEW YORK.

**KERR'S GLOBE AND GATE VALVES**



**STRICTLY HIGH GRADE. TESTED & PACKED**

**THE KERR ENGINE CO. LIMITED**

VALVE AND FITTING MANUFACTURERS

ST. CATHARINES, ONT.

## THE TELEPHONE

Is a Companion, Friend and Servant Combined.  
Invaluable for convenience in the household.

### LONG DISTANCE TELEPHONE SERVICE

has no equal for the facility it affords in business life.  
Full particulars as to rates and service at the nearest office of the

**BELL TELEPHONE COMPANY OF CANADA.**

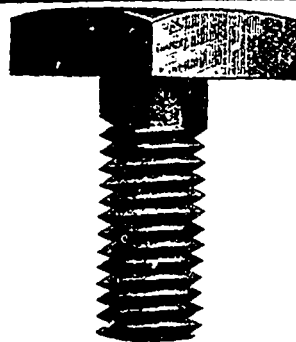

## PLANER SET and CAP SCREWS

**The John Morrow Screw, Limited**  
INGERSOLL - ONT.

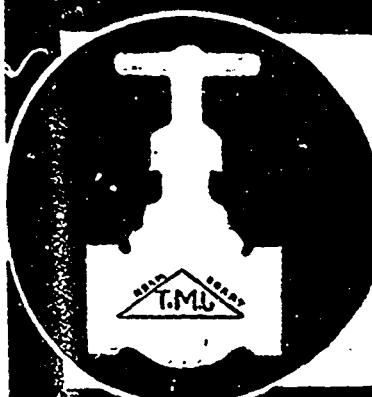

## If you want "QUALITY" STEAM and WATER GOODS

We make the largest varieties in the Dominion.

WE HAVE THEM.

**The James Morrison Brass Mfg. Co., Limited**

93-97 Adelaide Street West

TORONTO

## **ELECTRIC LAMP TESTING**

Do you furnish your own lamps?

Are you constantly renewing them?

Or increasing your light bill by burning them after they have become dim, in order to save cost of renewals?

**WHY NOT DETERMINE IF YOUR LAMPS ARE EFFICIENT AND FULFILLING SPECIFICATIONS BY HAVING THEM TESTED?**

**Electrical Inspection Bureau and Testing Laboratory**  
40 HOSPITAL STREET, MONTREAL.

**Motors, Dynamos,  
Fixtures, Shades,  
Heating Apparatus,  
Transformers,  
Telephones, Etc.**

**John Forman**

243-250 Craig St. W.,  
MONTREAL

**Toronto and Hamilton  
Electric Co.**

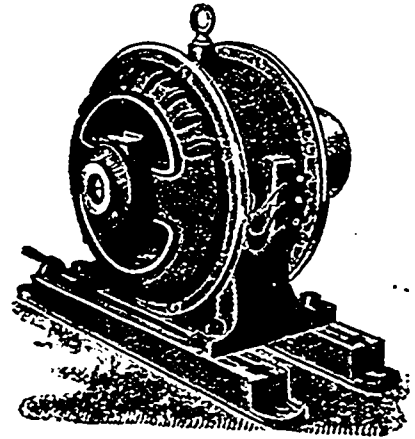

**ALTERNATING CURRENT MOTORS  
and DYNAMOS for all Circuits.**

**REPAIRS PROMPTLY EXECUTED.**

**99-103 McNab N. - HAMILTON, Ont.**

## **Suction Gas Producer Plants FOR MANUFACTURERS**

**Cheaper than Water, Simpler than Steam**

Let us quote you on units from 10 to 10,000 horse power

**CANADA FOUNDRY COMPANY, Limited**

**Head Office and Works: Toronto, Ont.**

District Offices:— Montreal Halifax Winnipeg Ottawa Vancouver Rosland

When writing to Advertisers kindly mention THE CANADIAN MANUFACTURER.

# Eugene F. Phillips Electrical Works, Limited

GENERAL OFFICES AND  
FACTORY, MONTREAL

CANADA

TORONTO BRANCH,  
67 ADELAIDE ST. EAST

## Bare and Insulated Electric Wire

Electric Light Line Wire, Incandescent and Flexible Cords.

## Railway Feeder and Trolley Wire

Americanite, Magnet, Office and Annunciator Wires, Cables for Aerial and Underground Uses.

Long Distance Phone 1163.

### The Electrical Construction Co. of London, LIMITED

32-40 Dundas Street, London, Can.

PERFECTION TYPE

### DYNAMOS AND MOTORS

Multipolar or Bipolar, Direct Connected or Belted.

Over 1500 of our machines in use.  
We contract for complete installations, including wiring of factories.

We repair machines of any make.  
Descriptive matter and estimates furnished on application

Branches at VANCOUVER. WINNIPEG. TORONTO.  
MONTREAL. HALIFAX

### The JONES & MOORE Electric Co., Ltd.

ELECTRICAL CONTRACTORS.

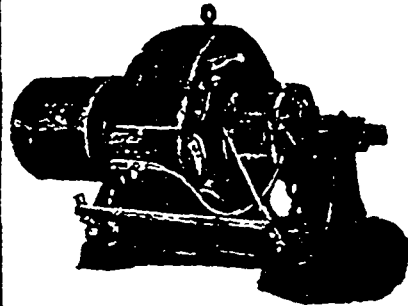

Dynamos, Telephones,  
Slow Speed Motors,  
Motors, Supplies,  
Direct Connected  
Dynamos.

We manufacture Direct  
Current Machinery in all  
sizes and for any purpose.

96 Adelaide West,  
TORONTO.

# CROCKER-WHEELER COMPANY

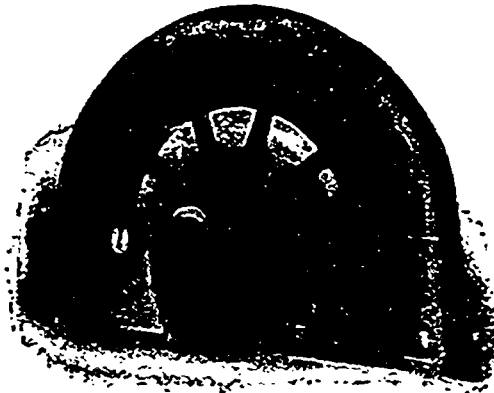

## ALTERNATING CURRENT GENERATORS.

Outputs—Belt Type, 25 K.V.A. up.

Engine Type, 75 K.V.A. up.

Canadian Representatives

## THE PACKARD ELECTRIC CO., Limited

MONTREAL.

ST. CATHARINES.

WINNIPEG.

**PROFESSIONAL DIRECTORY**  
 Patent Attorneys, Mechanical and Electrical Engineers, Hydraulic and  
 Constructing Engineers, Chemical and Mining Experts, Contractors and  
 Builders, Architects, Auditors, Accountants, Etc.

**CHARLES H. MITCHELL, C.E.**  
 Member Canadian Society Civil Engineers.  
 Member American Society Civil Engineers.  
 Assoc. American Inst. Electrical Engineers.  
**Hydro-Electric Engineer**  
 Rooms 1004-5 Traders Bank Bldg.,  
 Telephone Main 7306 Toronto

**K. L. AITKEN**  
**Consulting Electrical Engineer**  
 1003 Traders Bank Bldg.  
 TORONTO  
 Long Distance Phones (Main 1482  
 North 3119  
 North 1933

**DODGE & DAY**  
**ENGINEERS**  
 Mechanical, Electrical, Architectural  
**PHILADELPHIA, PA.**  
 Layout, Construction and Equipment of Indus-  
 trial Establishments.  
 We will send printed matter descriptive of  
 our work on request.

**C. J. FENSOM, B.A. Sc.**  
**Consulting Engineer**  
 ABERDEEN CHAMBERS, - TORONTO  
 Phones (Office, - - M. 1923  
 Residence, N. 2967  
 Machinery Designed, Supervised, Inspected and  
 Contracted for. Tests, Reports, Electric Light  
 Plants, Power Plants, Pumping Plants.

**PATENTS**  
**PROMPTLY SECURED**  
 We solicit the business of Manufacturers,  
 Engineers and others who realize the advisability  
 of having their Patent business transacted  
 by Experts. Preliminary advice free. Charges  
 moderate. Our Inventor's Adviser sent upon re-  
 quest. Marion & Marion, Reg'd., New York Life  
 Bldg., Montreal; and Washington, D.C., U.S.A.

**RODERICK J. PARKE**  
 A.M. AMER. INST. E.E.  
 A.M. CAN. SOC. C.E.  
**CONSULTING ENGINEER**  
 James Building, - - TORONTO  
 Long Distance Telephone.  
**TO MANUFACTURERS:** - Advice and speci-  
 fications covering Industrial Applications of Elec-  
 tricity - Lighting - Power Transmission -  
 Factory Power Distribution - Steam  
 Plants.  
**TESTS-REPORTS-VALUATIONS.**

**CHARLES BRANDEIS**  
 A. M. CAN. SOC. C.E.  
 MEM. AMER. ELCTRO-CHEMICAL SOC., ETC.  
**CONSULTING ENGINEER**  
 Estimates, Plans and Supervision of Hydraulic  
 and Steam-Electric Light, Power and Railroad  
 Plants, Specifications, Reports, Complete Factory  
 Installations, Electric Equipment of Mines and  
 Electro-Chemical Plants.  
 Long Distance Telephone Main 3236.  
 62-63 Guardian Building, MONTREAL

**ROBERT W. HUNT & CO.**  
**Bureau of Inspection, Tests and Consultation.**  
 16 Broadway, New York; 1121 The Rookery,  
 Chicago; Monongahela Bank Bldg., PITTSBURGH;  
 Norfolk House, Cannon St., E.C. LONDON.  
 Inspection of Rails and Fastenings, Cars, Loco-  
 motives, Pipe, etc.; Bridges, Buildings and other  
 Structures. Chemical and Physical Laboratories.  
 Reports and estimates on properties and processes.

**PATENTS**  
**TRADE MARKS, Etc.**  
**HANBURY A. BUDDEN**  
 NEW YORK LIFE BUILDING,  
 MONTREAL

Established 1873. Telephone Main 1889.  
**THOMAS HEYS & SON**  
 CHARLES H. HEYS, Manager.  
**CHEMICAL and MINING EXPERTS.**  
 Analyses of all commercial products, etc. Plans  
 and reports on mines and mining locations.  
 124 Yonge Street, TORONTO, ONT.

**Trussed Concrete Steel Company**  
 Manufacturers Reinforcing Steel  
 Concrete Engineers  
 23 JORDAN ST., TORONTO  
 GUSTAVE KAHN, Canadian Manager.

**W. H. STOREY & SON, Limited, Acton, Ont.**  
 Manufacturers of.... **FINE GLOVES and MITTS**  
 In every variety and style. Moccasins

**ANY COLOR OF CRAYON**  
 that you want can be obtained from us.  
 We are specialists for Cotton, Woolen  
 and Worsted Manufacturers. No trou-  
 ble to send samples.  
**LOWELL CRAYON CO., - Lowell, Mass.**  
 Original Manufacturers.

**A. C. NEFF & CO.,**  
**CHARTERED ACCOUNTANTS**  
 28 Wellington St. East, TORONTO  
 Phone Main 1330.  
 Audits and Investigations a Specialty.

MAIN 4834 Expert in Time Saving Devices  
**HENRI VIAU**  
**Business Methodizer**  
 (Accountant)  
 Room 14  
 "La Presse" Building  
 MONTREAL  
 Office Systems Installed

Rock, Ore, Cement, Clinker, Coal.  
**Crushers and Pulverizers**  
 The Senator Mill Manufacturing Co.,  
 Galt, Ont. Limited  
 We have Pulverizing Mills in eight Portland  
 Cement factories in Ontario and are building  
 Griffin mills for the Belleville plant of the Lehigh  
 Portland Cement Co.

**Sprinkler Leakage Insurance**  
 is indemnity paid for losses sus-  
 tained by the accidental di-  
 charge of water from installed  
 Sprinkler Systems.  
 Are you insured against  
 Sprinkler Leakage Damages?  
**The**  
**Canadian Casualty**  
**and Boiler**  
**Insurance Company**  
**TORONTO**  
 Insures Sprinklers, Boilers, Elevators and all  
 Personal and Property risks.  
**A. G. C. DINNICK, Managing Director.**  
 Head Offices:  
 22-24 ADELAIDE ST. E. and 55 VICTORIA ST.  
 Phone Main 4091

**KNOWLEDGE IS POWER. BE UP-TO-DATE.**

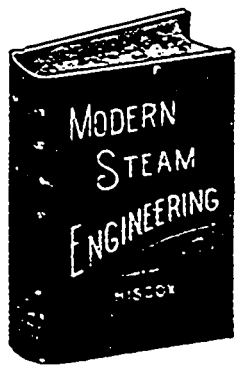

Technical books are a source of  
 definite information.  
**MODERN STEAM ENGINEERING**  
 In Theory and Practice  
 by GARDNER D. HISCOX, is one of  
 the latest.  
**PRICE \$3.00**  
 Fully illustrated by 405 specially made  
 Engravings and Diagrams.  
 Any other Technical Book published  
 may be had.  
**CANADIAN MANUFACTURER PUB. CO.,**  
 Toronto, Canada

**High "NOVO" Speed**

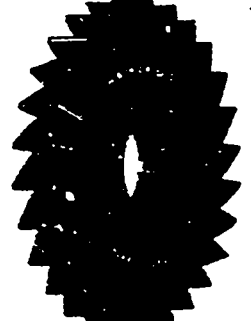

**Milling**  
**Cutters**  
**Twist**  
**Drills**  
**Reamers**  
**Drill Rods**  
**WILLIAM**  
**ABBOTT**

**Round,**  
**Square,**  
**and**  
**Flat Bars.**  
**Cutter Blanks.**  
**Sq. Cutters**  
**for**  
**Tool Holders**

331  
 St. James St.  
 Montreal

INDIVIDUAL CARS

The Monongahela River Consolidated Coal & Coke Company.

Youghiogheny Thin Vein Gas Coal, Connellsville Coke

Would you appreciate having your coal shipped during the coming year according to your contract, regardless of car shortage? If so write

F. J. DURDAN, Sales Agent, Prudential Bldg., Buffalo, N.Y.

ELK FIRE BRICK CO. ST. MARY'S, PA.

Best Fire Brick for Any Purpose.

There are none "just as good."

DUNBAR FIRE BRICK CO.

Manufacturers of High Grade FIRE CLAY and SILICA BRICK for Heating and Malleable Iron Furnaces, Glass Works, Cement Works—also Bee Hive and By-Product Coke Ovens, Brick and shapes of all kinds.

Pittsburgh Office: 1504 Arrott Building.

Office and Works: Dunbar, Pa.

Are you one of those who say to our canvasser, "Oh, I don't need a Mercantile Agency—I know my customers better than you do." Perhaps so, but just to satisfy yourself, bring a list of recent losses to our office. We will show you the reports we had when you shipped those goods on the say-so of some haphazard authority. We won't urge you to subscribe then—you will save us the trouble.

R. G. DUN & CO.

FIRE BRICK "Every Quality." "For Every Purpose." The TORONTO POTTERY CO., Ltd. FACTORIES IN OHIO TORONTO, CANADA

"Beech Creek" FIRE BRICK

STRICTLY HIGH GRADE

MADE ONLY BY

PENNSYLVANIA FIRE BRICK CO.,

BEECH CREEK, PA., U.S.A.

Special Mixtures for use in Rolling Mills, Malleable Iron Works, Steel Works, Blast Furnaces, Glass Tanks, Cement Kilns Locomotive Blocks, and all High Grade Uses.

Difficult Shapes a Specialty.

Send for Catalogue and Prices.

BRANDS: BEECH CREEK, BEECH CREEK ROOF, BEECH CREEK BUNG.

When writing to Advertisers kindly mention THE CANADIAN MANUFACTURER.



Grinding,  
Mixing  
and  
Blending  
Machinery  
for  
Liquids, Paste,  
Paints,  
Dry Colors  
Roots,  
Barks,  
Crystals,  
Powders,  
and  
any  
Grindable  
Material

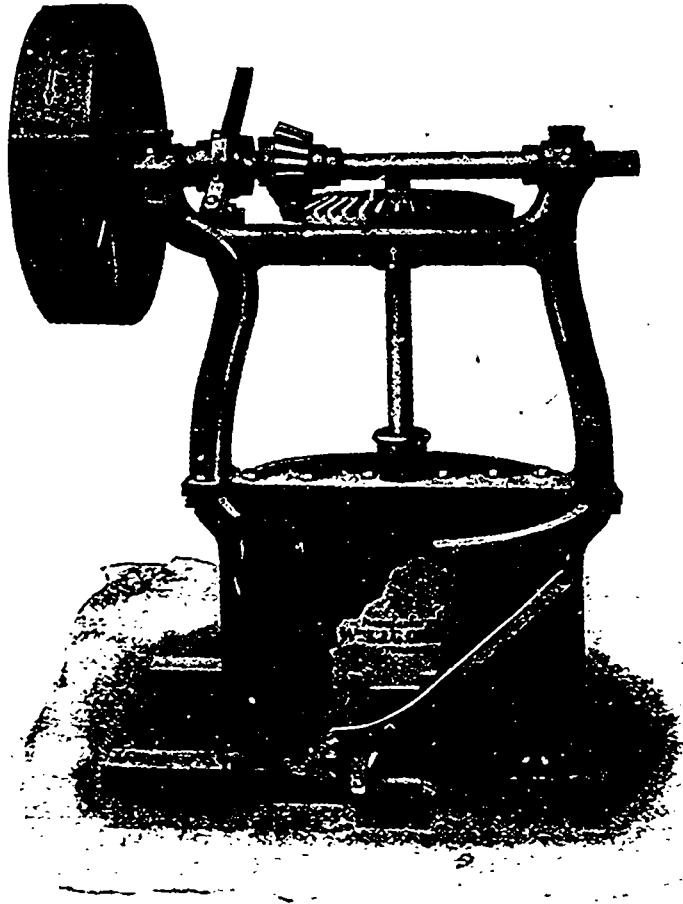

White Lead and Heavy Paste Paint Mixer.

**Wm. and  
J. G. Greey**

2 CHURCH STREET,  
TORONTO

Manufacturers

Flour,  
Oatmeal,  
Cereal Machinery,  
Paint and Ink  
Machinery  
Grain Choppers  
Grinding, Blending  
& Mixing Machinery  
Chilled Iron Rolls  
and Rolling Mills  
Trucks, Power  
Transmission and  
Elevating Appliances

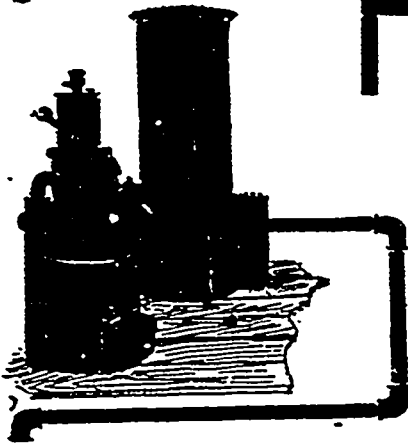

**CHEAPEST  
POWER  
PRODUCER GAS**

Relative Cost--Gas vs. Steam Power

Ordinary Steam Plant Burns 5 lbs. Coal Per H.P. Hour.  
Producer Gas Plant Burns  $\frac{1}{5}$  lb. Coal Per H.P. Hour.

**100 H.P. STEAM PLANT**

H.P. Hrs. Days lbs.  
 $\frac{100 \times 10 \times 300 \times 5}{2,000} = 750$  Tons

Cost at \$4.00 = \$3,000

**100 H.P. GAS PLANT**

H.P. Hrs. Days lbs.  
 $\frac{100 \times 10 \times 300 \times \frac{1}{5}}{2,000} = 112$  Tons

Cost at \$5.00 = \$560

SAVING on Fuel  
alone, annually) **\$2,440**

Specialists in Large Gas Engines and Plants.

**The Producer Gas Co.**

11 Front St. E., TORONTO.

**WRITE US.**

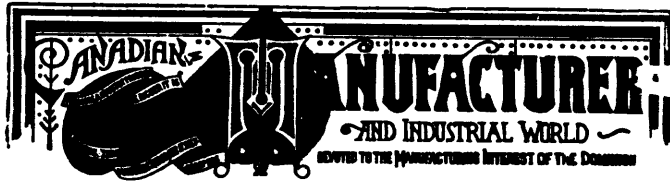

ESTABLISHED IN 1880.

PUBLISHED ON THE FIRST AND THIRD FRIDAYS OF EACH MONTH

**The Canadian Manufacturer Publishing Co., Limited.**

408 McKinnon Building, Toronto.

Also London, Eng., and Philadelphia, Pa.

J. J. CASSIDY,	}	Editors.
F. S. KEITH,		
D. O. MCKINNON,	-	Business Manager.
A. B. FARMER,	-	Subscription Representative.

Cable address: "CANAMAN." Western Union Telegraphic Code used.

**SUBSCRIPTIONS:**

Canada \$1.00. United States \$1.50 per year. All other Countries in Postal Union six shillings sterling, including postage.

Index to Advertisers ..... Page 49

**THE CANADIAN MANUFACTURERS ASSOCIATION CONVENTION.**

The Thirty-Sixth annual convention of the Canadian Manufacturers' Association was held in Toronto on September 24-25-26 last. As on a previous occasion, the meeting was held in the King Edward Hotel, a most excellent place, where every convenience was provided. The weather was all that could be desired, and the attendance roll including the names of over 400 members and invited guests, accompanied by mothers, wives, sisters and sweethearts. The managers of the affair provided receptions, excursions, theatre parties and other functions which were carried out in fine and generous style and without hitch: and an excursion to Hamilton where the excursionists were entertained by the local members and in most generous manner at Niagara Falls, on the invitation of the Board of Trade and the civic authorities of that enterprising Canadian city. They were occasions long to be remembered.

The business programme included the reports of the various committees which were discussed very entertainingly.

The election of officers and committees of the Association for the ensuing year resulted in the choice of the following gentlemen:

President: Hon. J. D. Rolland, of the Rolland Paper Co., Montreal.

Vice-President: John Hendry, of the British Columbia Mills, Timber & Trading Co., Vancouver.

Provincial Vice-Presidents: Ontario: R. Hobson, of the Hamilton Steel & Iron Co., Hamilton.

Quebec: D. L. McGibbon, of the Canadian Rubber Co., Montreal.

Nova Scotia: T. M. Cutter, of the Acadia Sugar Refining Co., Halifax.

British Columbia: R. P. McLennan, of McLennan, McFeely & Co., manufacturers of stoves, Vancouver.

Manitoba: L. C. Macintyre, of Paulin-Chambers Co., biscuits and confectionery, Winnipeg.

New Brunswick: Charles McDonald, of the St. John Iron Works, St. John.

Prince Edward Island: F. L. Haszard, of the Charlottetown Condensed Milk Co., Charlottetown.

Alberta and Saskatchewan: A. E. Cross, of the Calgary Brewing & Malting Co., Calgary, Alberta.

Treasurer: George Booth, of the Booth Copper Co., Toronto.

Secretary: To be chosen by Executive Council.

Chairmen of Standing Committees: Tariff Committee: P. W. Ellis, of the P. W. Ellis Co., manufacturing jewelers, Toronto.

Parliamentary Committee: John Turnbull, of the Nasmith Co., bakers and manufacturing confectioners, Toronto.

Railway and Transportation Committee: W. R. Dunn, of the International Harvester Co., Hamilton.

Commercial Intelligence Committee: J. H. Housser, of the Massey-Harris Co., Toronto.

Reception and Membership Committee: G. F. Beer, of the Eclipse Whitewear Co., Toronto.

Technical Education Committee: S. Morley Wickett, of Wickett & Craig, tanners, Toronto.

Insurance Committee to be self chosen.

British Office Committee: G. W. Watts, of the Canadian General Electric Co., Toronto.

Industrial Canada Committee: C. R. McCullough, of Ontario Engraving Co., Hamilton.

Chairmen of Association branches:—

Toronto: E. J. Freysing, of the Freysing Cork Co.

Montreal: S. W. Ewing, of S. H. Ewing & Sons, manufacturers of spices, etc.

City of Quebec: T. H. Hetherington, bread and biscuits.

Nova Scotia, at Halifax: Wm. Levis, of the Robert Taylor Co., manufacturers of boots and shoes.

Manitoba at Winnipeg: T. R. Deacon, 'Manitoba Iron Works, Winnipeg.

British Columbia, at Vancouver: to be chosen by branch association.

Executive Council:—Toronto:—

G. F. Beer, The Eclipse Whitewear Co.

Hugh Blain, Ontario Sugar Co.

S. S. Brush, Brush & Co., corsets.

P. H. Burton, Merchants Dyeing & Finishing Co.

J. W. Cowan, The Cowan Co., manufacturers of confectionery.

R. A. Donald, The Wood Products Co.

L. V. Dusseau, The Gendron Mfg. Co.

Thomas Findlay, The Massey-Harris Co.

John Firstbrook, the Firstbrook Box Co.

Atwell Fleming, The Atwell Fleming Printing Co.

R. S. Gourlay, Gourlay, Winter & Leeming, pianos.  
 W. P. Gundy, W. J. Gage & Co., printers.  
 S. R. Hart, Hart & Riddell, publishers.  
 Sam Harris, Harris Lithographing Co.  
 J. B. McLean, McLean Publishing Co.  
 J. P. Murray, Toronto Carpet Mfg. Co.  
 J. S. McKinnon, S. F. McKinnon & Co., milliners.  
 W. C. Phillips, Phillips Mfg. Co., wood workers.  
 Thomas Roden, Roden Bros., manufacturing jewelers.  
 A. S. Rogers, Queen City Oil Co.  
 Frank A. Rolph, Rolph & Clark, lithographers.  
 William Stone, Toronto Lithographing Co.  
 W. B. Tindall, Parry Sound Lumber Co.  
 A. W. Thomas, Copp Clark Co., publishers.  
 J. O. Thorn, The Metallic Roofing Co.  
 John Turnbull, The Nasmith Co., bakers and confectioners.  
 G. W. Watts, Canada Foundry Co.  
 S. M. Wickett, Wickett & Craig, tanners.

**Ontario representatives outside of Toronto:—**  
 C. Beningham, Canadian Locomotive Co., Kingston.  
 Henry Bertram, John Bertram & Sons Co., Dundas.  
 George Clare, Clare Bros. & Co., furnaces, Preston.  
 J. A. Coulter, John Morrow Machine Screw Co., Ingersoll.  
 Hon. E. J. Davis, Davis Leather Co., Newmarket.  
 J. D. Flavelle, Flavelle Milling Co., Lindsay.  
 H. W. Fleury, J. Fleury's Sons, agricultural implements, Aurora.  
 G. D. Forbes, The R. Forbes Co., woolens, Hespeler.  
 W. M. Gartshore, The McClary Mfg. Co., London.  
 James Goldie, flour miller, Guelph.  
 D. A. Gordon, Wallaceburg Sugar Co., Wallaceburg.  
 Lloyd Harris, Massey-Harris Co., Brantford.  
 E. G. Henderson, Canadian Salt Co., Windsor.  
 John Hewton, Kingston Hosiery Co., Kingston.  
 G. C. H. Lang, The Lang Tanning Co., Berlin.  
 R. O. McCulloch, the Goldie & McCulloch Co., Galt.  
 James McLauchlan, McLauchlan & Sons Co., Owen Sound.  
 R. McLaughlin, the McLaughlin Carriage Co., Oshawa.  
 James Maxwell, of David Maxwell & Sons Co., St. Mary's.  
 J. A. Publow, of International Harvester Co., Hamilton.  
 John Ransford, of R. & J. Ransford, manufacturers salt, London.  
 Wm. Robins, of Hiram Walker & Sons Co., Walkerville.  
 T. A. Russell, of Canada Cycle & Motor Co., Toronto Junction.  
 A. Saunders, of the Goderich Organ Co., Goderich.  
 T. H. Smallman, Canada Chemical Mfg. Co., London.  
 Henry Stroud, The Paris Wincey Mills Co., Paris.  
 J. M. Taylor, The Taylor-Forbs Co., radiators, etc., Guelph.  
 R. Thompson, of Penman's, knitted goods, Paris.  
 J. B. Tudhope, The Tudhope Carriage Co., Orillia.  
 C. R. H. Warnock, The Galt Knitting Co., Galt.  
 C. H. Waterous, the Waterous Engine Works Co., Brantford.

F. H. Whitton, The Ontario Tack Co., Hamilton.  
 R. J. Whyte, The Frost & Wood Co., agricultural implements, Smith's Falls.  
 C. I. I. Wilson, Ingersoll Packing Co., Ingersoll.  
 D. Wilson, of Wilson Bros., lumber, Collingwood.  
 J. W. Woods, lumbermen's supplies, Ottawa.

**Quebec Province representatives on Executive Council outside of Montreal and City of Quebec:**  
 F. J. Campbell, Canada Paper Co., Windsor Mills.  
 J. M. Jenckes, Jencks Machine Co., Sherbrooke.  
 A. G. Lomas, Magog Woolen Mills, Sherbrooke.  
 W. H. Rowley, The E. B. Eddy Co., Hull.

**Montreal representatives:**  
 John Baillie, Dominion Oilcloth Co.  
 Fred. Birks, Belding, Paul & Co.  
 S. S. Boxer, The Watson, Foster Co., wall paper.  
 J. H. Burland, Canada Engraving and Lithographing Co.  
 J. C. Cassavant, Cassavant Freres, St. Hyacinthe.  
 Wm. Cauldwell, Canada Paper Co.  
 James Davidson, the Thomas Davidson Co., enameled ware.  
 J. S. N. Dougall, of McCaskell, Dougall & Co., paints.  
 Joseph Horsfall, Montreal Woolen Mill Co.  
 J. J. McGill, of Durham Rubber Co.  
 Wm. McMaster, of Montreal Rolling Mills Co.  
 L. H. Packard, of L. H. Packard & Co., leather goods.  
 J. M. H. Robertson, of the James Robertson Co., paints, etc.  
 J. H. Sherrard, of Alaska Feather & Down Co.  
 Louis Simpson, Montreal Cotton Co., Valleyfield.  
 Wm. Smaill, Canada Horse Nail Co.  
 C. A. Smart, of Smart Bag Co.  
 E. Tougas, of P. D. Dodds & Co., paints, etc.  
 W. T. Whitehead, of Dominion Textile Co.  
 W. H. Wyman, of Corticelli Silk Co.  
 R. J. Young, of Canada Rubber Co.

**City of Quebec representatives:**  
 G. E. Amyot, of Dominion Corset Mfg. Co.  
 G. A. Vaudry, of J. A. Paquet, furs, etc.  
 W. H. Wiggs, of the Mechanics' Supply Co.; mechanics' tools.

**Nova Scotia representatives:**  
 W. J. Clayton, of Clayton & Sons, Halifax.  
 C. M. Crockett, of I. Matheson & Co., New Glasgow.  
 Alfred Dickie, of Alfred Dickie Lumber Co., Lower Stewiacke.  
 J. R. Henderson, of Brandrain, Henderson & Co., Halifax.  
 H. L. Hewson, of Hewson Woolen Mills Co., Amherst.

**Manitoba representatives:**  
 W. J. Boyd, of Boyd Candy Co., Winnipeg.  
 H. C. McLean, of H. C. McLean Publishing Co., Winnipeg.  
 John McKechnie, Vulcan Iron Works, Winnipeg.  
 D. E. Sprague, of the Sprague Lumber Co., Winnipeg.  
 G. F. Stephens, of G. F. Stephens & Co., paints, Winnipeg.

British Columbia representatives:

- G. F. Gibson, of Pacific Coast Lumber Co., Vancouver.  
 A. Leitch, East Kootenay Lumber Co., Cranbrook.  
 Alex. McLaren, North Pacific Lumber Co., Buckingham, Que.  
 Denis Murphy, Brunette Saw Mill Co., Ottawa, Ont.

New Brunswick representatives:

- T. H. Eastabrooks, importer of teas, St. John.  
 G. W. Ganong, of Ganong Bros., candy, St. Stephen.

Note.—The Executive Council is composed of the president, vice-president, treasurer, chairmen of the branches of the Association and of the chairmen of the sections, and one member for each twenty members of the Association.

#### CANADIAN MANUFACTURERS AND THE N.P.

The reports of several of the committees of the Canadian Manufacturers' Association to the recent meeting of the Association, and the discussions arising thereon, developed some very important facts and ideas that should not escape attention. We quote from the report of the Tariff Committee:

At the inception of the Manufacturers' Association the tariff question was the most important problem to be dealt with, and, in the opinion of your committee, it has remained as the one subject which must at all times be kept uppermost in the councils of the Association.

Since the revision of the tariff in 1896 the policy of this Association has been (1) to deal with the tariff as a business problem apart from party politics; (2) to impress upon the government . . . the point of view of the Association in desiring to build up Canadian industries, and provide employment for Canadian artisans, and (3) to educate public opinion, both in the cities and in the rural districts, to realize how essential this policy is for the complete development and continued prosperity of the country, and to obtain public support for a protective policy, no matter by whom it should be advanced. We believe that the country is imbued with the idea that Canadian industries must be protected against the products of cheap foreign labor and specialized industries. . . The public realizes more than it has ever done before, that the industries of Canada are providing a large and valuable home market for the products of the farm, and that everything should be done within reason which will develop them. . .

It is a source of satisfaction to manufacturers to know that the party in power, which was originally a low tariff or free trade party, has, under the responsibility of office, seen how impossible such a policy is if Canada is to continue her progress as an industrial nation. At the same time we feel that the Government has either not realized how essential it is, in the case of many industries, (which are even now, in these most prosperous times, feeling keenly the effects of foreign competition), that they should receive more adequate protection, or if they have realized it, they have not had the courage to put such a policy into effect. . .

We are not surprised to learn that since 1901 the output of our Canadian factories has increased by 48 per cent., but it is rather startling to know that they are not growing proportionately with the growth of our country, and that during the same period our imports of dutiable goods have increased by 53 per cent., and further, that a trade balance exclusive of coin and bullion, in Canada's favor in 1901 of \$6,000,000, has been converted into an adverse balance of \$104,000,000 for the year ending June 30, 1907. Fig-

ures such as these are fraught with deep significance, and "settlement day" cannot be explained away by any fiscal theories.

As a tariff committee we do not believe it would be in the interest of the manufacturers of this country to raise a hue and cry for increased protection for every Canadian industry. Some have sufficient protection to-day, others only very inadequate protection. . . .

We believe that the words of the Finance Minister in speaking of the position of the manufacturers on the tariff question, is correct—in other words that "eternal vigilance" must be the watchword of the Association. . . Instead of being disheartened, however, we believe the Association should be encouraged by the adoption by what was originally the free trade party of Canada, of a tariff which is protective in its principle, and that we should not relax our efforts to secure the application of the same policy of protection in those lines of manufacture which do not enjoy it to-day. . . .

We believe that, as in the past, our attitude on this question should be entirely outside of party politics, and that our efforts should be to deal with the question along business lines. . . .

That is the "Confession of Faith" of the Canadian Manufacturers' Association on the tariff question. It is for Canadian manufacturers generally to accept or reject it. It is like very thin and watery gruel. It has no ring like the clarion sounds that went up from the Old Guard of manufacturers thirty-six years ago when they formulated and adopted "the good old N.P."

The report was adopted by the convention, but not before some ringing protests were entered. Mr. Edward Gurney, one of the "Old Guard" who at one time was a president of the Association, and who has always taken a deep and intelligent interest in it, alluding to the warning of Finance Minister Fielding that "eternal vigilance" should be the watchword of the Association, insisted that such should be the key-note of the situation in spirit and in truth now. He maintained that the tariff question is inseparable from politics, and charged the Association with being pusillanimous and cowardly in the attitude taken regarding the tariff, and declared that he was in favor of a tariff "as high as Haman's gallows." A motion to delete the reference to party politics in the report was voted down, as was also a motion to cut out the clause reflecting on the courage of the government in not carrying out their tariff policy. Mr. George, of the committee, moved that the tariff report be discussed in private, but it was objected to; the gentlemen wanted to hear what was to be said on the question, and on a vote only two members supported the motion.

From the complex character the Association has of late assumed, it was reasonably to be expected that sooner or later disagreements and dissatisfaction would spring up. When the nucleus of the present association was formed thirty-six years ago it was for but only one purpose—to conserve the rights and interests of Canadian manufacturers in tariff matters. A large number of manufacturers regardless of their previous political adherences determined to use their best endeavors to place among the laws of Canada, and to keep it there, a tariff that should in all particulars give protection to all manufacturing and other material interests; and in this they were exceedingly successful; what was known as the National Policy of

Protection being the result. The activities of the Association were aroused when elections were pending, and when they were not pending but little was done. There was no necessity for special activity. There were careful and watchful officers and executive and tariff committees that were always alive to the necessities of the manufacturers. Such was the condition of the Association until a few years ago at the time of the re-organization of the Association when those who took charge conceived the idea that the sphere of usefulness of the Association should be enlarged, and they set about enlarging it, the result being the conditions that have since prevailed.

From the inception of the Association the objects of it were declared to be:

1. To secure by all legitimate means the aid of both public opinion and governmental policy in favor of home industries and the promotion of Canadian manufacturing enterprises.

2. To enable those engaged in all Canadian manufacturing enterprises to act in concert as a united body whenever action in behalf of any particular industry or of the whole body becomes necessary.

That was all. The qualification for membership stated "any person directly interested in any Canadian manufacturing industry is eligible for membership in the Association." That was all. "The membership of any officer of a company or member of a firm entitles the officers of the company or members of the firm to the privileges of the Association." No duplication of membership fees or anything of that sort. "The annual fee entitling to membership in the Association shall be \$10." "The standing committees of the Association shall be an executive committee, a tariff committee, and such special committees as the Association may consider necessary." There were some instructions as to how committees should be chosen, and their duties, meetings of the Association, conduct of meetings, order of business, and how to amend by-laws. That was all that there was to it in the way of laws for the Association for more than twenty-five years.

Under the present regime another constitution and by-laws has come into force, which have changed the face of affairs of the Association very materially.

#### A TARIFF LEAGUE NEEDED.

In another editorial, speaking of the report of the tariff committee to the recent meeting of the Canadian Manufacturer's Association, we recorded from that report what is now the "Confession of Faith" of the Association regarding the tariff. We showed that that confession was not the same that actuated the manufacturers when the Association was called into existence thirty-six years ago, and was so carefully followed until some seven years ago, when its management was re-organized.

Under the old regime the sole aim and object of the Association was the advocacy of the policy of tariff protection to Canadian manufacturing industries. Then no question was asked as to a man's political sentiments, the only requirements being that he must be a bona fide manufacturer and in favor of tariff protection to Canadian manufacturing industries. It has never been denied that

that Association had great influence in changing the personnel of the Dominion Government and the adoption of the fiscal system that accomplished so much for the manufacturing industries of the country. The Association was, pure and simple, a political organization with only one object in view, and without aiming for or desiring any political honors, it was free to affiliate with any political party that would adopt and carry out in good faith the tariff policy suggested, so vitally important to the manufacturers. There was no talk whatever of taking the tariff out of politics, and a suggestion to attempt to do so would have met with derision and scorn. That was the character of the Association from its inception thirty-six years ago until its re-organization within the present decade.

Then there arose those who knew not Joseph. They said that the objects of the Association were not expansive enough, and that the organization must be made more progressive. They would not confine the membership to manufacturers only, but would admit any who might be anything else, and willing to pay the ten dollar membership fee. Two things, they contended, were necessary for the reorganized association—members and money, and these they have had great success in obtaining, for, according to the report of the auditor-treasurer, the revenue of the Association for the expired financial year from membership fees was \$27,468 and from other sources enough to increase the revenue for the year to \$33,975. The cash expenditures account shows that of \$58,580, handled during the past year, \$5,000 are deposited with the Toronto General Trusts corporation and cash on hand \$10,298, the balance of \$43,281 going for the purposes of the Association. Of course these expenditures were entirely regular and vouchers produced for them, but members ask in what way they are benefitted by the expenditures? Certainly not one cent was expended in the cause of tariff protection.

The first act of the Association in 1902, was to formulate a constitution and by-laws which were embodied in the act of incorporation granted by the Dominion Government. The objects stated, and which have been generally carried out, are in strong contrast with those that met all the requirements of the Association for so many previous years. The Association undertook to further the interests of Canadian manufacturers and exporters, and to assist manufacturers and exporters generally, but the records do not show that any money has been expended in that direction. The powers of the Association include the rights to go as extensively as desired into the publishing business; to establish and dissolve branches; to engage in export trade; promoting an information and statistical bureau; to buy and sell real estate; to act as arbitrators, and to appoint committees to enquire into matters affecting the manufacturing, import or export trade. The membership shall consist of three classes; applications for membership must be passed upon by a committee who shall report to the executive council who have power to accept or reject. A by-law has reference to expulsion. Any member may be adjudicated upon by the executive council if charged with conduct un-

becoming a member of the Association. If, in the opinion of the executive council action should be taken thereon, a special committee shall be appointed to investigate and report. If the charges are sustained the member charged with unbecoming conduct, whatever it may be, shall be haled pro forma before the executive who may, by a majority vote, suspend the culprit from the privileges of the Association, or, on a two-thirds vote expel him. No mention, however, is made of what constitutes conduct unbecoming a member of the Association.

The officers and committees of the Association, chosen annually by the Association, are, president, first vice-president, provincial vice-presidents—one for each province, treasurer, executive council apportioned from each branch according to number of members in the branch, standing committees, viz., railway and transportation, parliamentary, commercial intelligence, tariff, reception and membership, Industrial Canada and insurance. Representatives are chosen to the exhibitions at five different exhibitions. The different branch associations are supplied officers—chairmen, vice-chairmen, secretary and executive committees. The branches are also supplied with sub-committees—dinner, reception and membership, technical education, smoke by-laws, legislation, civic league, etc., all of which indicates that the Association is in good working order, and ready and willing at all times to bite off all that comes within its reach, whether its digestive powers are able to masticate and digest it or not.

But manufacturers ask what the Association is doing, and what it has ever done under the present regime in behalf of tariff protection. The other features are all right in their way, but how many manufacturers take any particular interest in them?

What Canadian manufacturers need and should have is a tariff league to look after tariff matters, and allow the Association to look after the other things.

#### ANYTHING TO KILL PROTECTION.

When Sir Wilfrid Laurier and his party acceded to power one of the first things done by them was to give a tariff preference to British goods coming into Canada. This was done because of our filial love for the Mother Country and her manufacturers. It was found that in the fierce competition for Canadian trade British manufacturers could not successfully compete with American and German manufacturers, and the advantages of a tariff preference were necessary to enable Britain to continue in business. The preference needed the endorsement of the people of Canada, and the demands of imperialism and patriotism and lots of such guff were preached ad nauseam to help the cause. It was a well devised scheme to attack and lower the tariff, and a long step forward towards "free trade as they have it in England" that Sir Wilfrid had promised his friends as a reward for putting him in power. Of course it was a deliberate attack on Canadian manufacturers and their industries. If Sir Wilfrid's new tariff had been framed with a view to offering a tariff preference to British goods and at the same time do no injury to Canadian manu-

facturers, the schedules of the new tariff would have been increased against all other countries, while the preference would decrease them as affecting British manufacturers. But this was not the policy of the government, and the revision of the tariff that had been promised had the effect that in about all lines the interests of Canadian manufacturers were injuriously affected, and in many of them protection was entirely eliminated. Sir Wilfrid was quite willing, so he said, to make material sacrifices to British manufacturers, but they were made at the expense of Canadian manufacturers.

Strange as it may seem, the Canadian Manufacturers' Association lent a willing hand in the cutting of their own throats. At the Halifax convention in 1902, at the suggestion of their tariff committee, the association passed strongly worded resolutions in favor of a preferential tariff on British goods, to which they cling to this day. At the same time they demanded that the tariff be taken out of politics—a thing impossible of achievement. This removal of the tariff from politics was to be operative in Canada only, of course, for soon after making the declaration, the association made an excursion to Great Britain and busied themselves in meddling in politics in that country. The visit was made entirely in the interests of Chamberlainism, and to affect the British fiscal policy.

Sir Wilfrid made no comment on the event, but laughed in his sleeve at the readiness of the association to assist him in his efforts to destroy protection. He had eliminated much of the protection that had benefitted Canadian manufacturing industries, still further crippling them through the British preference. His success in this direction being so pronounced, the Manufacturers' Association rendering him such efficient and timely aid, his next step was to still further cripple home industries by extending tariff preference to other countries, and now we are told that a treaty has just been effected with France that will no doubt work well for the importers but very ill for our manufacturing industries.

Under the British preference the cut-rate tariff applied, or was supposed to apply only to British goods, the Canadian people and the Canadian Manufacturers' Association agreeing to the arrangement on patriotic grounds and because the beneficiaries of it were Britishers. But what is to be said of the effects of the new French treaty, which is to apply to Japan and other countries? The precise terms of that treaty have not yet been made public, but what is no doubt inspired information from government sources regarding it comes from Ottawa. We are told that "the new Franco-Canadian tariff treaty, just drafted in Paris, will affect also Canada's tariff duties on imports from Japan and from other nations included in the most favored-nation clause of Canadian trade treaties. Under that clause all British countries, Argentina, Austria-Hungary, Bolivia, Columbia, Corea, Denmark, France, Algeria and French colonies, Japan, Siberia, Morocco, Persia, Russia, Sweden, Salvador and Venezuela are entitled, in return for trade and tariff privileges granted Canada to the tariff rates granted the most-favored nation. The provisions of the new agreement with France are not yet published, but it may

be taken for granted that the principal concessions given to France will be on wines, champagnes and silks exported to Canada. These form now by far the largest items in Canada's import trade with France. In 1906 Canada imported French silks and silk fabrics valued at \$678,262, and wines valued at \$1,019,839. From Japan last year Canada imported silks to the value of \$471,565, this being the chief item of Japan's exports to this country. Under the treaty with Japan any tariff concession granted France on silks must also be granted to Japan. Consequently it will be seen that Japanese silk exporters will likely profit by the new treaty affected with France. In respect to the other chief item in the tariff changes, that affecting the tariff on wines and champagne, Spain is the only other country chiefly concerned in the Canadian trade. It was at first thought that Spain would also come under the most favored nation clause, but a further examination by members of the Government of the trade treaty with Spain leads them to the belief that any tariff concessions granted to France need not necessarily apply also to Spain. The other countries included in the above list compete with France in but very few of the articles exported by the later country to Canada, and in the articles of export which do coincide with those sent from France the volume of trade is so small at present as to be practically negligible in considering the effect of the new treaty on Canada's tariff rates against other countries."

The bad effects of this treaty are minimized as far as possible, and it is shown that the tariff involved is quite small. The unfortunate unmarried girls' excuse for the babe in her arms was that it was a very little one.

To show the improvidence and lack of foresight of our statesmen in negotiating this treaty, while we were led to suppose that it was a thing that was to affect only France and Canada, investigation that should have been made beforehand, but was not, shows that whatever benefit is to accrue to France is also to be enjoyed by Argentina, Austria-Hungary, Bolivia, Columbia, Corea, Denmark, Algeria and other French colonies, Japan, Siberia, Morocco, Persia, Russia, Sweden, Salvador and Venezuela, and God knows how many other countries. Why? Because British law says so, Why should Canadian interests be thus sacrificed, except that the theory of free trade should be propagated and amplified in Canada. The most of the countries mentioned are mostly grain producers, and their products come in competition in the markets of the world with the products of the Canadian farmer.

In an election in the United States when the Democrats were doing what they could in favor of Mr. Cleveland's a war cry they raised was "anything to beat Grant.", The free trade party in Canada adopt "anything to defeat protection."

#### "TRADE LAUGHS AT TARIFFS,"

"It is fortunate for the people in protection countries that trade laughs at tariffs, and that they never succeed in accomplishing what they undertake."—The Globe.

The above is a fair specimen of the sort of stuff that the Globe feeds to the dupes of a free trade theory which

the organ preaches and dare not practise, says the Toronto Telegram.

"Even free trade can be discredited by the Globe-Star type of shallow pettifogging attorneys who ask a growing country to be guided by the platitudes of Adam Smith instead of by the principles of life.

"The Globe theory is that tariffs make no real difference, that the laws which enforce the exchange of products between nations are as fixed as the law of gravitation and that every country has free trade even while it imagines it has protection.

"If low tariffs and high tariffs are alike in their powerlessness to disestablish free trade why does the Globe object to Canada having a high tariff?

"If, as the Globe says, "trade laughs at tariffs," Canada might as well provoke the mirth of trade with a high tariff as with a low tariff.

"Canada is content that trade should laugh at tariffs. Canada needs the sort of tariff that the United States will not laugh at. That sort of protective system is honored with the enmity of the Globe, Star and other pro-American tariff organs. The very life of these organs depends on the prosperity of Canadian industry, and they think more of their precious free trade stupidity than of the industrial greatness of the country."

#### BRITISH COLUMBIA TIMBER LANDS.

United States Consul Smith, of Victoria, B.C., in an official report to his government, says that the sale of timber lands in that province continues to increase, and shows that large investments of American capital are being made there. It should be borne in mind that most of the lumber manufactured in British Columbia is exported to the United States, as intimated in the report of Consul Smith, or to other countries by these American saw mill men; and large quantities of British Columbia round timber are supplied to American mills on the Pacific Coast. Round logs pay no duty when going into the United States, but all sawn lumber is subject to a duty of \$2 per thousand feet at least. The timber on these lands is the result of the growth of many years, and the most careful and scientific system of reforestation will be required to produce a new growth of commercial value. The removal of this timber, and its exportation to foreign countries is precisely in the nature making Canada a producer of raw materials for the manufacturers of other countries. Certainly no round logs should be taken out of the country, and sawn lumber should pay an adequate export duty.

Consul Smith says:

The official report shows that from January 1 to May 1, 1907, there were issued by the provincial government 152,262 licenses for as many square miles of timber land, from which the revenue derived was approximately \$282,500. But the record was reached during the month of May, when the total amount contributed from this source to the provincial treasury was \$137,000. The demand for standing timber is very great, and American syndicates seem to be successful in securing the bulk of the timber lands in spite of keen rivalry from eastern Canadians. That the demand and sales are steadily

increasing is shown very conclusively in the number of timber-cutting licenses issued during the years 1903, 1904, 1905, 1906, and for the first six months of the present year, which are officially stated as follows:

1903.....	1,307
1904.....	1,451
1905.....	2,175
1906.....	3,959
1907, (six months ending June 30)....	4,245

These figures are exclusive of hand loggers' licenses and they show a remarkable increase in the average of land staked, as each license represents approximately 640 acres, so that the number of acres covered by timber licenses in each year would be:

	Acres.
1903.....	836,480
1904.....	938,640
1905.....	1,390,720
1906.....	2,534,400
1907 (six months ending June 30)....	2,716,800

This large increase for the first half of 1907, coupled with the fact that the number of applications for licenses shows no diminution, indicates that the area under license by the end of 1907 will be more than double that of any former year. Official estimates state that in British Columbia there is an area of forest and wood land aggregating 285,554 square miles. All over this extensive area are large sections, each of many square miles, owned or leased by American syndicates and controlled by American capital. The available timber area of Vancouver Island alone reaches the large figure of 8,000,000 acres.

As showing purchases of British Columbia timber lands made by American investors, it may be stated that during the present year a Michigan syndicate purchased 50,000 acres of timber land in the Klanch River country, in the northern part of Vancouver Island, which land is estimated to hold 3,000,000,000 feet of fir, yellow and red cedar, and white pine lumber. This company is building mills, also a railroad 22 miles long to enable them to ship their lumber, making a total investment of nearly \$2,000,000. The Standard Oil Co. has purchased 50,000 acres of timber lands at Ash and Dixon lakes, near Alberni, on this island, on which are fir and cedar trees in large quantities, the investment amounting to millions. So far nothing has been made public as to whether the company proposes to cut and sell the timber or to hold the property for an advance.

A syndicate of Iowa capitalists has purchased 210 square miles of timber lands on Vancouver Island and the mainland, declaring their intention to erect mills on the island and cut lumber for the export trade. This company say they expect to invest \$2,000,000 in the province. Other large purchases by American syndicates are being made every week, while small capitalists are also making investments, which in the aggregate foot up immense sums.

It is noteworthy that the most of the large investments by Americans in British Columbia timber lands have been made by wealthy lumber men, who now own or have made their money in large manufacturing enterprises in the Eastern and Middle States. They have literally poured their money into British Columbia, because, as several have declared to the writer, they regard the timber lands in this province as the last that can be secured at nominal rates on this continent. As Wisconsin and Michigan forests were forty years ago, so are the timber lands of British Columbia to-day. This large amount of American cash coming into the province is a veritable boom to the people and Government, both of whom are now more prosperous than at any time in their history.

## EDITORIAL NOTES.

During August twenty-six trades disputes were reported in Canada, affecting 200 establishments and 6,144 employes. The loss of time involved by these disputes during the month was equivalent to 99,860 working days. Seven of the disputes were settled during the month, leaving 19 unsettled. Of the seven settlements the employers were successful in three, a compromise was affected in one, in another case the occasion of the dispute was removed, and in two cases the results were indeterminate, the matters in dispute being left to arbitration and conciliation boards.

Mr. Edward Gurney desires a tariff as high as Haman's gallows. Since this historic edifice was fifty cubits high, is this an intimation that Mr. Gurney wants a fifty per cent. tariff?—The Globe.

If a fifty cubits high, or a fifty per cent, tariff is required to afford proper protection to Canadian manufacturing industries, let it be that high. If that is not high enough let it be higher. Mr. Gurney is right.

A tariff as high as Haman's gallows—how the Canadian Manufacturers' Association should thank Mr. Edward Gurney for condensing the creed in such a striking simile!—Toronto Star.

They do, or at least they ought to. Mr. Gurney is one of the "old guard" who was present at the bornin of the Association thirty-six years ago and was active and influential in the formation and adoption of the N.P.—"the good old N.P.," and his striking simile, like other good words, shines like a bright and beautiful light in a naughty free trade atmosphere. Mr. Gurney hits the nail on the head.

The International Harvester Co., of Wisconsin, has paid a fine of \$35,000 for violating an anti-trust law of Texas, and has consented to a perpetual injunction restraining it from operating in the State. Texas farmers will in future be fleeced to the extent of the tariff by individual manufacturers, not by a great combination.—The Globe.

This is not good nor appropriate language for a reputable newspaper to utter. It is false in every respect. The "individual manufacturers" of harvesting machinery in the United States are as honest as the individual editors of free trade journals in Canada, and only the lowest and meanest sort of editorial politicians indulge in such language.

Are we to gather, then, that the Canadian Manufacturers' Association would have it this way—free trade in labor and restricted trade in everything else?—Toronto Star.

What is wanted is the removal of restriction on the free entry of good workmen into Canada to the end that Canadian manufacturers may produce such goods as the country demands. Why not give Canadian manufacturers and Canadian labor the benefit of the production at home of the millions of dollars in value of the goods that are being imported?



# The Annual Address of the C.M.A. President.

MR. HARRY COCKSHUTT, RETIRING PRESIDENT OF THE CANADIAN MANUFACTURERS' ASSOCIATION  
REVIEWS THE INDUSTRIAL SITUATION.

As Canadians we are proud of our agricultural industry; we are proud of the men who have made it what it is, and we are glad to do honor to them here to-day.

It is indeed a pleasure to note the steps our Federal and Provincial governments are taking to foster the growth of this important industry, and to establish it upon a sound and economical basis. No one will rejoice more heartily than the manufacturer in the success which has followed the work of the experimental farms. In so far as they have contributed to a better understanding of the scientific side of agriculture, and made it possible to grow two blades of grass where one grew before, they have benefitted not alone the farmer, but the entire community. The same is equally true of the encouragement given by the government to agriculture in other ways. The attention which is paid to dairying, cold storage, and the marketing of Canadian butter and cheese abroad has worked wonders for the farm. The government has taught our farmers, as it were, the first principles of manufacturing; it has shown them how to turn out a more highly finished article; how to utilize wastes in the manufacture of by products, and how to prevent depreciation of plant, which, in their case, means how to prevent soil exhaustion.

## ENCOURAGE FORESTRY.

It is gratifying, too, to note the awakening of interest in another of our basic industries—I refer to forestry. This subject is one of such tremendous scope that it is impossible to do more than touch upon its fringe. Apart altogether from the material uses to which they are put, forests are of incalculable value in tempering our climate. They are a potent factor in inducing rainfall, and in regulating the run-off of surface water. Without them the rivers of Canada, particularly in hilly districts, would be raging torrents to-day, and insignificant streams to-morrow. The magnificent waterfalls which mean so much to the industrial future of our country would fluctuate between extremes that would make hydraulic development well nigh impossible. Last year Canada imported over six million tons of coal, worth on a very conservative estimate, \$25,000,000, and when one considers the extent to which these importations might be replaced by the white coal of electrical energy, one cannot but be impressed with the importance of preserving intact so valuable an asset.

The Superintendent of Forestry has stated that at the lowest estimate 281,240 square miles of wooded land are still vested in the Crown. Providing this land will yield only 2,000 feet per acre, or 1,280,000 feet to the square mile, over 10 inches at the stump, it means a production of 359,987,200,000 feet of matured timber on which the government royalty at the rate of \$1 per thousand would be \$359,987,200. Canada stands first among the countries of the world in forest wealth.

## PORTFOLIO OF FORESTRY.

The whole question is one of such tremendous importance to Canada that it is surely time we were adopting a vigorous forestry

policy. It seems to me that the first step to this end should be a careful stocktaking of our national possessions. We must not lose sight of the fact that in this matter we are simply acting as trustees for posterity, and that even as we have received a priceless estate from our forefathers, so will it be our duty in turn to hand it over to those who are to follow us with its value unimpaired. I would favor the immediate creation of more forest reserves. Particularly is it important that the heights of land where so many of our rivers find their sources should be under perpetual forest.

The administration of such an estate is, I believe, of sufficient importance to justify the government in creating a portfolio of forestry. In addition to the duties above referred to a Minister of the Crown might render valuable service in encouraging the establishment of schools of forestry, where practical instruction would be given on a subject which seems destined to form the groundwork of one of our foremost professions.

## EXPORT DUTY ON PULP.

In this connection I wish to express my strong personal sympathy with the proposal to place an export duty on pulp wood. The United States consumes 2,500,000 cords of pulp wood every year, of which Canada now supplies 25 per cent. By allowing this material to leave our country in its unmanufactured state we are simply contributing to the upbuilding of our greatest industrial rival, whereas the imposition of an export duty would unquestionably compel the investment of United States capital in Canadian pulp mills; would provide employment for thousands of Canadian workmen, and would ultimately open the door for the sale of Canadian pulp across the border. Every year we defer our decision in this matter we relatively weaken ourselves and strengthen a highly protected competitor whom we already have reason to fear; moreover, we postpone the enjoyment of a prosperity which is well within our reach.

## MANUFACTURING STATISTICS.

The importance of Canadian factories to the community at large happily needs little pointing out. There was a time not so very many years ago when public opinion consigned them to a secondary position in the scale of industries, but the expansion they have undergone in recent times has entirely dispelled any erroneous ideas as to their real significance.

But perhaps the best touchstone to determine the economic value of any industry is the number of people to whom it gives employment and the amount of money it distributes in wages. When measured by this test manufacturing stands pre-eminent among its fellow industries. In 1905 the wage-earners in Canadian factories numbered 391,487, as against 344,035 in 1900, a gain for the five years of 47,452. Wages for the same period increased from \$113,249,350 to \$164,394,490, a gain of \$51,145,140, or 45 per cent. In 1900 the average yearly wage per employe was \$329.17, in 1905

it was \$419.91, a gain of \$90.74, or 27 per cent. Comparisons with previous years tell a story of progress and expansion of activity in their workshops, of business for their shopkeepers, and of home comforts and more congenial surroundings for their working classes. Conditions more favorable than those for the Canadian producer could scarcely be desired, for the competition he had had to meet in the home market from the products of specialized industry and cheap foreign labor had been at its lowest ebb. It was not surprising, therefore, that he should have made considerable progress, and they were quite prepared for the census announcement that during the five-year period the output of their factories had increased from \$481,053,371 to \$717,118,092.

And yet, substantial as this growth may seem to have been, Canadian manufacturers have no more than kept pace with the expansion in other directions. At any rate they have not materially strengthened their hold on the home market, as may be seen from the following simple calculation: If to the output of our factories for any year we add the imports of manufactured goods, and from the amount so obtained deduct the exports of manufactured goods, the result should represent the home consumption of manufactured goods, providing we leave out of consideration the stocks carried over unsold, which we have no means of estimating

## WANT MORE OF HOME MARKET.

And, further if from the output of our factories we deduct the exports of manufactured goods the result should represent the proportion of manufactured goods marketed at home. By following out these various steps, with the aid of figures supplied me by the Census Department, I find that the home consumption in 1901 was approximately \$539,953,002, of which Canadian manufacturers supplied \$401,221,709, or, roughly, 74 per cent. By 1906 the home consumption had increased to \$792,930,286, of which Canadian manufacturers supplied \$595,830,253, or, roughly, 75 per cent. Relatively speaking, therefore, the manufacturers of this country are in the same position to-day that they were five years ago. Their capital has increased, their wage bill has increased, their output has increased, but their share in the Canadian home market has remained practically at a standstill.

The trade and navigation returns give further evidence of the fact that we are not progressing as we should. Compared with an increase in factory production between census periods of 48 per cent., the imports of dutiable goods, goods which are taxed to encourage their production in Canada, show an increase of 53 per cent. Our export trade shows a regrettable tendency to fall away. Comparing the figures of 1907 with those for 1906 in the exports of merchandise, there is an actual decrease of \$5,862,754. Ever since 1901 our imports have been increasing much more rapidly than our exports, with the result that a balance of trade in our favor that year of \$6,072,107 has for the twelve months ending June last, been converted into an adverse balance of \$104,476,142.

When writing to Advertisers kindly mention THE CANADIAN MANUFACTURER.

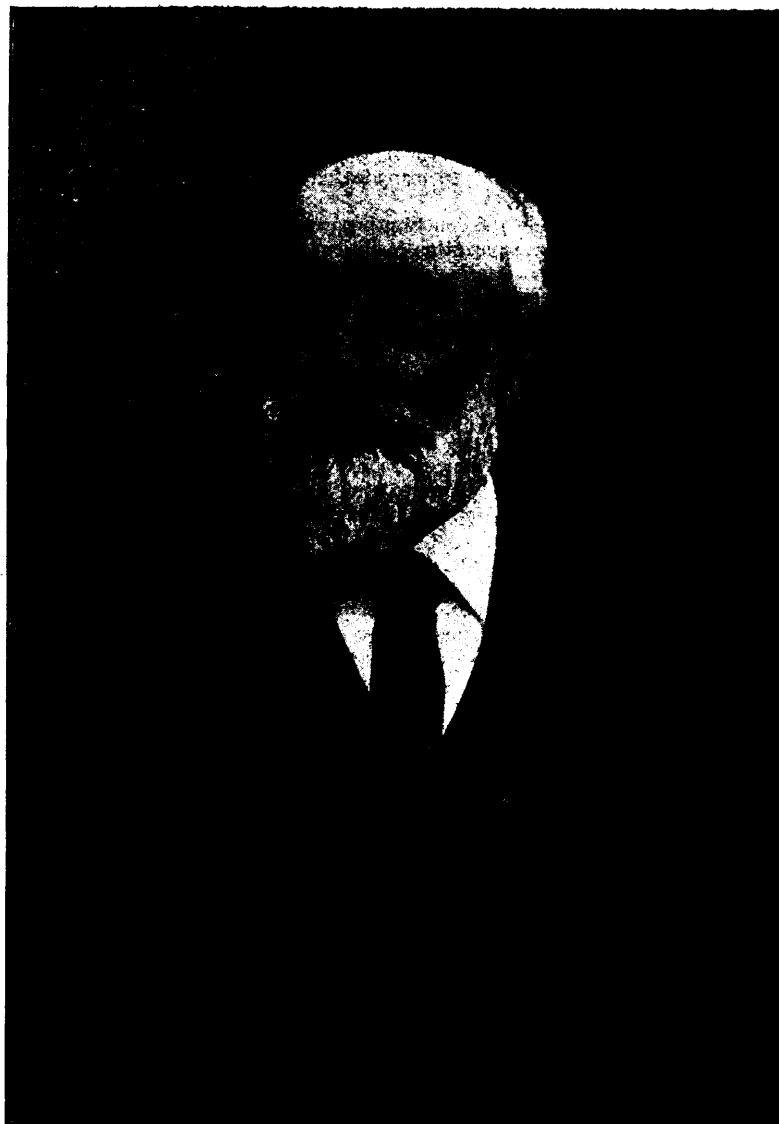

HON. J. D. ROLLAND, PRESIDENT OF THE CANADIAN  
MANUFACTURERS' ASSOCIATION.

#### MORE PROTECTION NEEDED.

Such conditions should not obtain in a young country like Canada, for, with the variety and abundance of our natural resources combined with native enterprise, we should easily be able to produce enough for our own requirements and have a substantial surplus to sell to countries that are more thickly populated and less richly endowed. By the adoption of a policy sufficiently protective, such as our association has always advocated, capital would be irresistibly attracted by the opportunities here afforded. Our home market would be supplied by home industries, manufacturing would become more specialized, the cost of production would be reduced, and a substantial beginning would be made towards the development of an export trade that would successfully carry us over any ordinary period of domestic depression.

#### AN INADEQUATE TARIFF.

It is deeply to be regretted that the significance of the figures above referred to did not appeal to the government when making their revision of the tariff, for they clearly indicate what we may expect, under a continuance of the present policy, when the inevitable period of depression overtakes us. A tariff, which under the most favorable circumstances barely enables our manufacturing establishments to relatively hold their own, cannot but prove utterly inadequate to stem the swelling tide of imports when the foreign producer seriously and systematically prepares to unload his surplus products on the Canadian market.

And this he will do as surely as the sun will rise on the morrow, the moment when darkening days begin to restrict his trade in other quarters. No hastily improvised tariff will then suffice to secure for Canada a continuance of her present prosperity. Retrenchment, not expansion, will be the policy of capital. Production will be curtailed, workmen will be thrown out of employment, and hard times will once more be found knocking at our doors.

We believe it to be the part of wisdom to guard against the possibility of such a situation materializing by affording immediate encouragement to the investment of capital in our manufacturing enterprises. It is only by so doing that we can firmly entrench ourselves against foreign competition and build up the industries of our country on a sure and solid foundation.

#### PREFERENTIAL TRADE.

Our attitude towards the policy of an Imperial preference has been so frequently misconstrued that it becomes my duty to repeat what all my predecessors in office since 1902 have stated in their annual messages. As Canadians we stand first and foremost for the upbuilding of our own country. Our aim is to produce from Canadian materials and with Canadian labor everything which the economic conditions of this country permit of our producing. To this end we ask for a tariff whose minimum protection will be high enough to reserve the home market for the Canadian manufacturer. We realize, however, that there are many articles we do not and cannot produce in this country, and when it becomes necessary for us to go abroad, we believe in a preference which will give the Mother Country and our sister colonies the refusal of our trade, before passing it on to foreigners. In other words our motto is

"Keep your money in circulation at home by buying goods made in Canada, and when you cannot get what you want at home, buy within the British Empire."

#### FINANCIAL STRINGENCY.

Deep, however, as has been our disappointment over tariff revision our attention is today centred in an even more serious situation. Danger has arisen from an unexpected quarter.

Like a threatening cloud the scarcity of money began to be noticed on the financial horizon early in the year. Slowly, but steadily it has advanced, spreading itself out in all directions until to-day the outlook is more or less overcast.

Paradoxical, though it seemed, trade is very good. Orders are plentiful. Factories are working to their capacity. Settlers keep hurrying to our shores in steadily increasing quantities. Yet there is an embarrassing lack of money to provide for the necessary expansion.

Some of the contributing causes are inadequate transportation facilities throughout the winter, interfering with the marketing of last year's crop and with the deliveries of manufactured goods, so that collections were delayed and orders cancelled. Western real estate speculation had also run riot, and money which should have been sent East to discharge indebtedness to manufacturers and wholesalers went into land purchases.

The listing of some scores of Cobalt mining stocks on the Toronto and Montreal Mining Exchanges, and the seeming opportunity thereby afforded of acquiring a fortune quickly, and without effort has resulted in the closing out of many savings bank accounts. Provincial loans which might have been negotiated abroad have been negotiated at home, to the detriment of Canadian industry, whose credit could not so easily be pledged in Europe. For five years prior to 1906 there was a steady growth in the amount of coin and bullion in the country, the imports always exceeding the exports by a substantial amount. Last year, however, the tide was turned in the other direction, and we lost over \$2,000,000, while for the twelve months ending June, 1907, our supply was decreased by a further \$8,000,000. This fact seemed particularly significant when considered in connection with the adverse balance of trade previously referred to, for it indicated that if we could not settle our foreign obligations in goods we must sooner or later settle them in money.

#### LACK OF SKILLED LABOR.

A further obstacle to the natural expansion of our manufacturing enterprises, an obstacle that seems to be ever present with us, is the scarcity of skilled labor. All branches of trade have suffered more or less from this cause during the present year. The country is growing, new districts are being opened up, the market for manufactured goods is expanding, but the strength of our artisan class shows no tendency to increase in proportion. In five years the number of workpeople in Canadian factories has increased by only 12 per cent. whereas the wages paid have increased 45 per cent. It is not, therefore, a question of wages. The average employer is willing to pay anything within reason. But the workmen are not to be had; they are not in the country.

The difficulty admits of but two solutions,

either we must import more artisans from other countries, or we must provide educational facilities whereby our own young Canadians will be able to qualify themselves for the more important positions in our factories. The first method is the one means of obtaining immediate relief; the second is the one means of ensuring an adequate supply for our future needs.

It is to be regretted that the government has not seen its way clear to meet the wishes of the association in regard to the immigration of skilled mechanics. Without any desire to belittle the importance of providing the country with more farm hands and more railroad laborers, we maintain it is only fair and reasonable that our immigration policy should reflect the requirements of all classes of industry. To stimulate development in one department, and leave another unprepared to meet the sudden demands that must inevitably be made upon it is, we believe, shortsighted and unstatesmanlike, and it is with reluctance that we have been compelled, since our last annual meeting, to assume the expense of encouraging this class of immigration ourselves.

#### TECHNICAL EDUCATION.

It is further to be regretted that the government has hesitated to act in the matter of technical education. The rapid development of trade schools and schools of technology in all the great industrial countries of the world practically forces upon Canada a policy of liberal encouragement in this direction, if she is to keep pace with the advancing quality of foreign manufactured products. Technical education, more than anything else, is an incentive to individual effort amongst our working classes. It opens the door to industrial preference, elevates the standard of living, and removes one of the most fruitful sources of unrest and discontent.

#### INDUSTRIAL DISPUTES.

One of the most regrettable features of the labor situation is the steady growth in the number and importance of industrial disputes. According to the Labor Gazette, there were 128 strikes in Canada during the twelve months of 1906, the largest for any year on record, with the single exception of 1903. The number of people directly affected was 26,041, and the actual loss of working days was 489,775. Even at the low estimate of \$1.50 per day, this means a direct loss to the working people of our country for one year of \$734,662. And yet it represents but a fraction of the loss to the community at large, for to it we must add the loss entailed upon manufacturers and employers through the suspension and disorganization of their business, as well as the general falling off in trade by reason of the diminished purchasing power of our labor classes.

From whatever point of view they may be regarded, strikes are always to be deplored. As a prominent welfare worker in the association recently remarked, "You never win but you lose." Financially they are a dead loss to the country, for in stopping the wheels of industry they stop production, and production is the only way to increase wealth. Socially they create conditions conducive to violence and lawlessness on the one hand, and suffering and privation on the other. For these reasons I am of the opinion that our association would be undertaking a noble work if it would devise means of reducing the number of industrial disputes.

## TRANSPORTATION FACILITIES.

The present equipment of Canadian lines is far from sufficient to meet the demands made upon them by the Canadian shipping public is all too apparent. While our vessels are providing a better service and carrying a bigger tonnage, they are delivering less freight to Canadian ports and more to United States ports. In proportion to the miles of road in operation, there were fewer locomotives in 1906 than in 1905. This is perhaps offset to some extent by the increased traction power of the new style locomotive, yet the significant fact cannot be overlooked that for the operation of 866 miles of new track only 25 locomotives were provided. All the figures which I have quoted clearly indicates that our companies are making little progress towards taking care of the growing volume of

traffic on the older portions of their lines. As a result of their failure to provide the necessary facilities business is being diverted into other channels, and the ports of a foreign country are being built up at the expense of our own.

In so far as this condition is due to congestion, the railway companies cannot be held wholly to blame. Manufacturers themselves have in many cases failed to keep their freight handling equipment up to the proper standard. For this they must be held strictly to account. But the railways have been by far the worse offenders. In order to head off future competition they have spent their money in building new lines through undeveloped country, when they should have spent it in properly equipping the ones already in operation. As a result every section has suffered from the shortage of cars.

## Canadian Electrical Exhibition.

MARKS AN IMPORTANT ERA IN ELECTRICAL DEVELOPMENT IN CANADA. MANY FINE EXHIBITS.

The First Annual Electrical Show, held in the Drill Hall, Montreal, from September 2 to September 14, inclusive, attracted a large number of Canadian exhibitors, and several introducing new lines from the States. During the second week conventions of three important electrical bodies were held in Montreal, the Canadian Electrical Association, the Canadian Street Railway Association, and the Maritime Provinces Electrical Association, bringing many visitors to the city.

The booths were arranged with five aisles running the full length of the building. The white frames of the booths with colored trimming gave a clean, cool, and pleasing effect to the eye. In the centre of the hall played a beautiful electric fountain, while high above, on the wall to one side, the dancing skeleton tirelessly repeated some surprising stunts.

Just a word in passing about the skeleton and his father.

The Dancing Skeleton, or Dancing Devil, was built by Mr. Reynolds Dull, of the Reynolds Dull Flasher Co., Chicago, the inventor of Dull's Flashers, and works on the same principle as the well known snake or spelling out effects. The skeleton is 20 feet high, and his performance requires about 600 lights, the effect of motion being produced by the turning on of different sets of lights showing the outline in different positions. The Reynolds Dull Flasher Co. also showed the most complete line of flashing devices ever seen in Canada for producing flashing and changeable effects.

The above company were associated in their exhibit with the Martel Stewart Co., of Montreal, who showed some new and up-to-date products of the sign maker's art. They had some very tasty effects, a great many entirely new to Canadians, ranging from small illuminated transparencies to large spectacular and animated effects for use in large cities.

## MODERN ELECTRIC COOKING.

A popular exhibit at the Montreal Electrical Show was that of the Canadian General Electric Co., largely owing to the fact that in their modern kitchen, viands were given away and coffee served, all cooked by electricity. Every cooking device needed in a

household was ably demonstrated by a corps of enthusiastic young ladies who dispensed coffee with their descriptions of electric ovens, chaffing dishes, frying pans, disc heaters, cereal boilers, corn poppers, sad irons, water heaters, curling iron heaters, etc.

Next to the kitchen was seen a sewing machine driven by an electric motor which may be attached to any house circuit. Portable electric drills for alternating current and a special fan for forcing a fine spray of water to humidify the atmosphere were among the novelties.

Tables were covered with samples of electric devices of all kinds, one table contained a large piece of crude rubber which is used to insulate the many colored finished cords and wires shown in profuse variety, another contained incandescent lamps in all stages of manufacture from the glass bulb and cellulose filament to the finished lamp.

Electric meters of many kinds were shown all connected so as to show their actual working one of which made a record on paper of the actual current used every minute of the day, and another in which it was necessary to deposit a ten cent piece before you could obtain an equivalent amount of current.

At the further end was seen a train of seven direct-current motors being operated from the alternating current circuit through the medium of a mercury arc rectifier.

Distributed through the exhibit were a number of handsome stands each containing three arc lamps of new and artistic designs.

The whole was lit by a group of high efficiency incandescent lamps, including the well known G.E.M. lamps of different sizes and the new Tungsten lamp, giving a most brilliant light on a small consumption of current. The most attractive lamp was the German Nernst, emitting a beautiful white light and fixed in most artistic holders.

On another aisle was the overflow exhibit comprising a full line of type H transformers from 600 watts to 50 k.w. and a mammoth 200 k.w. for central station work.

Here a 1,000 pound electric hoist for warehouses attracted much attention, lifting a steam pump of which there were several

shown, made by the Canada Foundry Co., Limited, as well as a complete line of buda jacks and track drills.

## THE NORTHERN ELECTRIC &amp; MFG. CO. EXHIBIT.

The exhibit of the Northern Electric & Mfg. Co., of Montreal, at the exhibition was one of exceptional interest to those who were connected in any way with telephone or fire alarm affairs.

The telephone apparatus was a complete exhibit of modern switchboards from a small ten line magneto board for rural exchanges to the very latest type of central energy switchboard in use in all of the largest cities. Telephones of several types designed for use under all sorts of conditions from a rural party line of 25 subscribers to one for use on a large 10,000 line system was the most attractive feature of the Exhibit.

This company also manufacture a very complete line of fire alarm apparatus consisting of signal boxes of several types suited to systems of all sizes. Registers, gongs, indicator and central office equipment. The city of Montreal is equipped with apparatus manufactured by this company.

Another interesting feature of the exhibit was the complete line of condit oil immersed switches and circuit breakers. The Northern Electric & Mfg. Co. are the Canadian selling agents for these switches.

A line of vulcan electric soldering tools, shown in sizes and shapes especially adapted to various classes of work in the telephone business where uniform and reliable results are absolutely necessary. The Northern Electric & Mfg. Co. has secured the Canadian general agency and manufacturing rights for these thoroughly practical and high grade tools, the advantages of which are so fundamental that their general adoption in place of furnace-heated coppers is secured. A 24 inch soldering tool of only  $\frac{1}{2}$  inch diameter, for use in congested multiple switchboard repairs, is a very interesting example of the unequalled adaptability of these electrically self-heated tools.

## ELECTRICAL INDUCTION DEMONSTRATED.

One of the most attractive features of the Show was the booth of Fred. Thomson & Co., where a number of interesting experiments with induced currents were repeated at intervals during each afternoon and evening. A flat coil of insulated copper wire connected to a 110 volt alternating current circuit and a number of similar coils and bundles of wire having their ends connected to incandescent lamps of different voltages and to arc carbon points, but having no connection whatever with the first coil, were used to show in an interesting way how currents were induced in the coils and the lamps lighted when the lines of force cut the coils, and that the lines of force would pass through plate glass, glass bowls containing water, and even light an incandescent lamp connected to a coil contained in a solid mahogany box. The effect of using an iron core instead of air as a medium for conducting the lines of force was also shown and the different lamps were lighted with the coils held at much greater distances from the first coil. Another flat coil was used to show that when the induced current in the second coil was short circuited the two coils tended to oppose each other, and in this experiment the second coil which

weighed about 25 pounds practically floated in the air unsuspected above the first coil.

Messrs. Fred. Thompson & Co., who do perhaps the largest repair business in Canada, had a display of form wound coils of different sizes and several types of surface and slot wound armatures and exhibited some of their drop forged 100 per cent. pure copper commutators in the different steps of their manufacture. An item of interest to many was the work of rewinding armatures performed by two of their employes. When the writer passed by, one of the men was at work on a 50 light T-H Royal arc armature and the other on a G.E. 57-Railway motor armature, two radically different types.

This firm manufacture special apparatus of all kinds, and have built wireless apparatus for the Marconi, the Stone Stone, and the Dominion DeForest Wireless Telegraph companies, and attention to this exhibit was called in a positive manner by the occasional sharp crack—crack! of the 20,000 volt spark coming from the Dominion DeForest Wireless apparatus which was kindly loaned them for this occasion.

#### AN EXHIBIT OF LAMPS AND GLASSWARE.

At the Montreal Electrical Show one of the most noticeable exhibits was that made by the engineering department of the National Electric Lamp Association in behalf of the Sunbeam Incandescent Lamp Co., of Canada, in conjunction with the Holoplane Glass Co. The booth was splendidly illuminated by rows of lamps of various types and sizes with their accompanying glassware. Among the new high efficiency lamps shown were the Tungsten 40 c.p. street series lamps, 80 c.p. multiple lamps and 27 volt lamps. These lamps are the latest creation of the lamp manufacturer and effect a saving of 60 per cent. in power consumption. Tantalum filament lamps in 40 and 80 watt sizes as well as miniature types were shown in round and straight sided bulbs. This lamp operates on any circuit at an efficiency of 2 watts per candle.

For showing the saving effected by the use of high efficiency lamps wattmeters were used with the various lamps. The effect of varying voltage on the candle power of the new lamps was shown to be less noticeable in the case of the high efficiency lamps than with the carbon filament lamps.

A feature of the exhibit was the excellent display of glassware shown. Holoplane shades and globes of various designs were on exhibition. Their better lighting effect was clearly shown by comparison with ordinary clear lamps.

A number of valuable bulletins pertaining to lamps and illumination were distributed to those interested.

Mr. Ed. Irving, the popular manager of the Sunbeam Co., and Mr. T. R. Price, of the same company, with whom were associated representatives of the National Electric Lamp Association and the Holoplane Co., made visitors welcome at this exhibit.

#### ALUMINUM PLAYS A PART.

The Northern Aluminum Co., of Shawinigan Falls, had a very attractive exhibit of their various products, including aluminum wire and cable for electrical conductors, fuse wire, bus bars, and various mechanical joints.

An interesting feature of the exhibit was a sample of the 61 strand 500,000 C.M. cable

used by the Canadian Niagara Power Co., for their crossing over the Niagara River from Fort Erie to Buffalo, the longest span being about 2,050 feet.

On account of the great demand for aluminum this company have been behind with orders, but large extensions have been made at their plant at Shawinigan Falls and they are now in position to make prompt deliveries on their products. The exhibit was in charge of Messrs. Stanley and Hamilton.

#### ELECTRIC OLD MAN.

Duntley's Magnetic Old Man was a feature of N. J. Holden & Co.'s exhibit that appealed strongly to those interested in structural iron work. The Old Man is wound for both direct and alternating current, and will hold on to any iron structural work at any angle with a force of 500 pounds. It has an arm, which is centred to be lifted to any desired height. This firm also carry a full line of electric drills, hoists, and grinders, in any winding. Duntley air cooled tool port grinders, small portable hand grinders, blowers for blowing away cuttings in stone and metal work, portable hoists, and a full line of pneumatic tools of both Boyle and Keller types, including rivetters, clippers, lettering tools, etc., completed the exhibit.

#### ELECTRIC FIXTURES.

The Canadian Electric Co., of 55 St. Francois Xavier Street, Montreal, had a very attractive exhibit of electric and combination fixtures, in hanging, bracket and desk designs. They also had on exhibition a local and general electric bell system similar to that recently installed in the convent of the Soers de la Providence convent by this firm.

#### WIRE—ALL SIZES.

Much attention was attracted to the booth of the Wire & Cable Co., by the triple deck braider, braiding 500,000 circular mile cable. Their other exhibits included wire of almost every kind. There was a reel of 20 conductors, aerial telegraph cable, a reel of lead covered paper insulated 400 pairs, telephone cable, a reel of 1,200,000 c.m. stranded power cable, lead sheathed, for underground service. Three pyramids were used to show rubber covered wires, weatherproof wires, and slow burning and slow burning weatherproof wires. A revolving pyramid displaying lamp cords, distributing frame wire, keyboard wire, and plain insulation wire was an ornamental feature. Fine copper wire for telephone coils, bare and silk insulated cotton covered magnet wires, for armature and field coils, annunciator wires, office wire, samples of 1,000,000 c.m. triple braid weatherproof cable, bare copper cable, 3 stranded rubber covered lead sheathed cable for 6,000 volt service, and hard drawn trolley wire were also shown. A display of crude rubber, used in the manufacture of rubber insulation, was an interesting feature.

#### BRITISH ENGINES.

Laurie & Lamb, consulting and contracting engineers, Board of Trade Bldg., Montreal, had an inviting little booth decorated with pictures, notable among which was a 1,500 k.w. 200 Bellis triple expansion engine in the Leeds Corporation Power House. Another photo showed the 1,500 kwts triple expansion engine in the Birmingham Corporation power house, one of six sets of the same size. Another photo showed a large Canadian installation of Bellis engines in the

Warden King & Co. power house. They also showed a sample of the Foster patent superheater.

#### OZONATOR.

The Sayer Electric Co. showed a full line of art fixtures, electric novelties, and telephones. They also showed the ozonator, a machine for the electrical sterilization of air, for treatment of lung troubles.

#### TELEPHONE EQUIPMENTS.

The exhibit of the Bell Telephone Co. included all equipment supplied to subscribers in Montreal. In this booth was the switchboard connecting the phones in the exhibition. A smaller switchboard with a capacity of 10 exchange lines and 30 locals was also on exhibition. The various telephone sets shown included the regular business sets, the portable desk set, the extension set for residence, pay station set and booth, and bells, gongs, etc., for phones.

#### LAMP DISPLAY.

The Midland Electric Co., Montreal, showed a beautiful display of electric lamps, in many sizes and designs, including desk lamps, bronze and china figures, beaver lamps, with the anchored filament were well shown. The oscillating fan was approved, and the electric pipe and cigar lighter made many friends.

#### LESSON IN GEOLOGY.

A lesson in geology, with some relation to other things, was the exhibit of the A. Roy Macdonald Mica Co., with Mr. Macdonald for instructor. Here were shown samples of mica in the natural state, samples of hematite, bitite, and muscovite, samples of Indian mica, used extensively for stove purposes, and for the manufacture of flexible mica, of which a fine sample was shown. Much interest was also shown in a section of a tube two feet in diameter, 1½ inches thick, which when completed will be 10 feet long, containing over 5,000,000 pieces of mica. This is the largest piece of solid mica tubing on record. Other mica products, including fine samples of talcum powder were also shown.

#### FIBRE CONDUIT.

The Fibre Conduit Co., of Orangeburg, N.Y., had a neat exhibit of indurated fibre conduit for underground and station work. A souvenir in the form of a pin tray made of fibre conduit was given to visitors.

#### COMPRESSED AIR.

The Canadian Rand Co. had in constant operation a small motor driven compressor fitted with an unloading device which automatically shuts off air in the compressor, when the required pressure is reached, then taking only power enough to overcome friction. One important use of this compressor is in blowing out electrical machinery to prevent accumulation of dust. One of the large photos in the booth showed the pneumatic rock drills in use on the excavation work at Niagara.

#### PURIFYING THE ATMOSPHERE.

The Canadian Buffalo Forge Co., Limited, exhibited an air washer and humidifier in operation used in conjunction with the Canadian Buffalo fan system of heating and ventilating. The humidifier regulates the humidity of the air entering a ventilation system, and removes all dust and smoke.

## POWER APPARATUS.

Allis-Chalmers-Bullock had a number of features of unusual interest. In one section several girls were at work winding and insulating coils and small motors. A two stage turbine pump, built by the John McDougall Caledonian Iron Works Co., one-tenth the size of the one recently supplied by the same firm to the McTavish St. station was shown, direct connected to a 40 h.p. Allis-Chalmers-Bullock motor. Attached to the pump was a needle nozzle, such as is used for controlling Doble water wheels. Many were interested in a sample of the special blading used in the famous Allis-Chalmers steam turbine. A conspicuous feature of the exhibit was an 11,000 volt alternator, built for the Algoma Power Co., for direct connection with a water wheel. In this alternator the coils have been treated by a machine recently installed at the works, which under heavy pressure forces a special insulating compound into the coils, and so effectively as to render break down in insulation practically impossible.

## BOILER FORGINGS.

Babcock & Wilcox, of Montreal, showed some of their special forgings and samples of pressed steel work, for use in connection with their boilers. These forgings are made from plates of the highest grade open hearth steel. They also exhibited samples of their standard boiler fittings, which were appreciated by practical men. This firm are building and installing a very large number of boilers for various parts of the Dominion, amongst their largest customers being the Canadian Pacific Railway, the Montreal Street Railway, Halifax Electric Railway, Intercolonial Railway, Canada Car Co., Dominion Steel Car & Foundry Co., Wire & Cable Co., Northern Electric Mfg. Co., and many others.

## POWER Co.'s EXHIBIT.

The Shawinigan Water & Power Co. had an attractive booth, where pictures of various Shawinigan industries were on exhibition. There were also samples of insulators and cables used on their lines.

## WESTINGHOUSE APPARATUS.

The Canadian Westinghouse Co. had on exhibition a huge 1,500 h.p. railway type generator, which the company have manufactured for the new Hochelaga power house of the Montreal Street Railway. They also showed a 4,000 h.p. transformer, built for the Provincial Light, Heat & Power Co., which will reduce 44,000 volts to 12,000, and is one of the six largest in Canada. Of special interest to machinists and metal manufacturers was a London Machine Tool Co.'s lathe operated by a Westinghouse variable speed motor, and controlled directly from the carriage of the lathe. With the back gears this machine has 32 speeds forward and 12 reverse. A static sign operated from a 60,000 volt transformer, drew frequent crowds. Near the main entrance the company built the fore part of a car, showing the Westinghouse system of multiple control, by which any number of cars can be controlled from one cab. The company also showed a complete line of testing instruments.

## LIGHTING SYSTEM.

The Nernst lamp was the light chosen by the Exhibition Association for general lighting at the Show. This lamp gives a brilliant, steady white light, with ideal distribution in

all downward directions. The filament in the Nernst lamp is a combination of oxides, and at the operating temperature has only half the resistance of the old carbon filament. The whiteness of the light, which is practically true to daylight, has brought it much favor.

## FIBRE CONDUIT.

The American Conduit Co. had an exhibit of bituminized fibre conduit for underground wiring. The exhibit included samples of sleeve and socket joints, bends, a section of road construction showing conduits laid in concrete, and a box of water showing the water tight properties of conduit and joint.

## PHOTOS OF POWER PLANTS.

The Electrical Development Co., of Ontario, Limited, and the Chicago Edison Electric Co., had a booth in which were albums of photographs relating to their plants.

## HIGH GRADE FIXTURES.

Munderloh & Co. displayed some very beautiful effects in elegant electroliers and ceiling lights. Among their fixtures were some of the handsomest Paris bronzes ever shown in Montreal. A prominent section of their exhibit was the display of their "Helios-Munder" arc lamps, both "multiple" and "flaming," which are favored for their brilliancy, steadiness and economy. In the centre of the supply section a great volt meter registered the voltage in the building. A separate booth was given to the demonstration of the "Munder" socket, by which much time and annoyance are saved in wiring, and the danger of the shell becoming loose is overcome.

## GAS AND ELECTRIC FIXTURES.

The Garth Co., 26-32 Craig Street, Montreal, exhibited wrought iron bends and cast iron fittings up to 12 inch diameter, and screwed and flanged fittings for all pressures and requirements. A 16 inch die for threading pipe up to 16 inches in diameter, and a smaller die for 12 inch pipe manufactured by Cox & Sons Co., Philadelphia, were shown. The exhibit also included fire extinguishers and a beautiful display of gas and electric fixtures manufactured by the Garth Co.

## WIRE AND CABLES.

Eugene F. Phillips Electrical Works, Montreal, had a souvenir for everybody in the form of small samples of wire-grooved trolley wire, slow-burning weatherproof and weather-proof slow burning wire, incandescent lamp cord in assorted colors, and telephone cord. They also had on exhibition samples of telephone cable, magnet wire, copper wire of all sizes and shapes, spark coils, etc., and a 2,420 pound reel of 00 trolley wire.

## HIGH TENSION INSULATORS.

Canada contains so much undeveloped water power that interest in electric power transmission is always active among engineers and the exhibit of the Locke Insulator Mfg. Co., of Victor, N.Y., is noteworthy since it contains one of their 100,000 volt insulators, a contract for 150 miles of which has just been placed with this company for the lines of the Stanislaus Electric Power Co., California. Representative types of standard "Victor" insulators are also shown. The company was represented by John S. Lapp, secretary-treasurer and Walter T. Goddard, electrical engineer.

## ELECTRIC REPAIR SHOP.

The booth of W. J. O'Leary, Montreal,

took the form of a repair shop, in which several men were engaged in winding form coils for armatures, repairing and building X-ray apparatus, etc. A part was devoted to the demonstration of the auto electric safety switch, which automatically cuts off in case of dangerously high voltage. An elaborate crystal chandelier made and assembled at the factory was on exhibition. During the exhibition a 300,000 volt Tesla transformer was built under the direction of Mr. L. R. McDonald.

## A WIDE VARIETY.

John Forman, 248-250 Craig Street West, Montreal, had an instructive exhibit, including Sangamo meters, American transformers, Patrick, Carter & Wilkins annunciators Connecticut telephones, John Manville electric railway supplies, Western Electric arc lamps, Chase Shawmut fuse blocks and cut outs, Lima porcelain insulators, Heintze spark coils, and Connecticut spark coils, Sta-rite spark plugs, Crofton storage batteries, American electrical heating apparatus, electric light fixtures, and other lines of supplies.

## MONTREAL LIGHT, HEAT &amp; POWER Co.

A feature of the decorations of the Montreal Light, Heat & Power Co. was the use of Elblight wire. This cable is such that lights which are prepared with two sharp prongs may be stuck into the cable at any point and make a light.

A number of interesting electrical lines were shown in the Montreal Light, Heat & Power booth.

## CHOPPERS AND COFFEE MILLS.

Emory & Williams, 225 Coristine Bldg., had on exhibition the Royal electric coffee mills and meat choppers, made by the A. J. Duer Co., of Buffalo, N.Y., and Beckel's improved meat and bread slicing machine, made by Van Beckel's, of Rotterdam, Holland.

## MULTIPLE CLUSTERS.

The Benjamin Electric Mfg. Co., of Toronto, attracted much attention by their arc-burst and holoplane arcs, both of which give the same efficiency as an arc lamp with a 27 per cent. saving in current. Their wireless cluster for multiple and series work was approved by electricians generally for its neatness, durability, and simplicity, only two wires being necessary to light from two to seven lights, instead of two for each light. Their multiple plugs and window lighting fixtures were shown to good advantage.

## VARIOUS EXHIBITS.

Shelton electrical vibrating appliances were shown by Mr. Stargardter, of 415 St. Catharine Street West, the Montreal agent.

The "1900" Junior Washer exhibited by the Montreal branch of the 1900 Washer Co. was a suggestion to the housekeepers to let the power company do some of the heavy work. It was operated from a 16 c.p. light at a cost of about one cent per hour.

The Universal electric adding machine and the electro addressograph were an advance over the hand machine in point of speed.

The Canadian Vacuum Cleaner Co. had on exhibition a 5 h.p. electric machine, and demonstrated its use on carpet and hardwood floors. The machine has also been adapted to cleaning boiler flues in a clean way.

Marsh Bros. showed some attractive elec-

tric signs, including Skidoodle winking signs. All the signs shown are automatic, and do not require motors.

Other features of the Power Co.'s booth were electric soldering irons, electric coffee percolator, water urns and chafing dishes, plate warmers, water bottle heaters, cigar lighters, medical sterilizer and electrophones.

The exhibit of J. A. Dawson & Co. was under the personal supervision of Mr. Dawson ably assisted by Messrs. Lewis, Allan and Warren, and Mr. Keyes, of the Consolidated Car Heating Co.; Mr. Mack, of Crouse Hinds Co.; Mr. Prouty, of McCallen Co. It included the Consolidated Car Heating Co.'s electric heaters, the Crouse Hinds headlights, McCallen overhead line materials, and the famous "Projectile" brand of gears and pinions, all of which are carried in stock by this firm. An elaborate line of electric supplies such as are used by telephone companies, factories, and the public in general, was also shown. The attention of the general public was attracted by a display of "Pacific" electric smoothing irons.

Dossert & Co. had a valuable feature in a solderless cable joint, the simplicity and efficiency of which was amply demonstrated by Messrs. J. J. and E. A. Dossert, who were in charge. Among the special connectors shown was a third rail emergency clamp, for the New York Central lines, by which all delays caused by a dead third rail can be temporarily adjusted in fifteen minutes and avoid the blocking of trains. The Dossert solderless connectors are allowed or adopted by the National Board of Fire Underwriters, and nearly all the larger traction companies of the United States. They are also being installed in many large mills and factories.

The Economical Electric Lamp Co. had on exhibition their economical turn down lamps.

The Stratton engine exhibited by the Stratton Engine Co., of Fitchburg, Mass., came in for considerable attention.

The Linde British Refrigerator Co., of Canada, Limited, showed a small self-contained refrigerating machine driven by electric motors similar to a number that have been installed in apartment houses and private residences. This little machine has a refrigerating capacity equal to the melting of 2½ tons of ice per day. The firm build refrigerating plants of all sizes up to the largest used in breweries and cold storage plants.

A feature of the booth of the Imperial Ice Cream Co. was an exhibit of ice cream moulded in novel forms, including flowers, automobiles, electric lamps, and other forms. The booth was very popular.

#### FAIRBANKS DOUBLE EXHIBIT.

One booth of the Canadian Fairbanks Co. was devoted to a display of scales of many designs for various purposes. The other exhibit was devoted to machinery, including a Fairbanks-Morse 2 h.p. special electric lighting and pumping gas engine, connected with a pump, and also to a dynamo of 35 light capacity, Fairbanks-Morse alternating current generators, and Fairbanks-Morse steam pumps. A Yale & Towne electric hoist of 4 tons capacity, was a model of compactness and convenience. The company also exhibited Norton alundum grinding wheels, india oil stones, Pratt & Whitney small tools, and some large gate valves manufactured by the Graham Co., of Chicago.

#### SPECIAL DEVICES.

The exhibit of the R. E. T. Pringle Co. included many lines of interest. One of these was the "P. & A." remote control switch, of a useful device for the control of motors and lights by a push button switch at a distance. They also showed a line of "D. & W." sparkless plugs and enclosed fuses. An interesting demonstration was made with Deltabeston magnet wire, showing the superiority of its insulation as a heat resistor. One of Pringle's self-starting motors of 5 h.p. was attached to the lighting circuits. In the lighting line they had the well known Adams Bagnall arc lamps, used by the Montreal Light, Heat & Power Co., and Beck flaming arcs. A line of Hubbel specialties, manufactured by this company was shown, including Hubbell pull sockets, attachment plugs, flush plugs and wire lamp guards, shades and reflectors.

#### PAINT EXHIBIT.

The Standard Paint Co., Limited, had on exhibition a full line of the famous P. & B. electrical compounds, insulating tape, armature varnish, and P. & B. paints, used extensively for preserving iron and metal work. A model of a factory building showed in a practical way how a roof may be covered with Ruberoid, without the use of metallic flashing and gutter work.

#### TRACK WORK AND TRUCKS.

Among the numerous objects of interest at the Electrical Show is the exhibit of the Montreal Steel Works.

Their exhibit, consisting of cast manganese track work and trucks for electric railways,

shows clearly what has been done for the comfort and safety of the travelling public, and the economical maintenance of street railways.

All the track work shown is made of the best quality of manganese steel. This steel, the invention of an eminent English maker, is peculiarly adapted for street railway track work. Great wearing quality is combined with extreme ductility, and although it is so hard that it is impossible to cut it except with an emery wheel, it can readily be bent through an arc of 180 degrees without fracture. Compared with the old style of built-up track work the life of solid manganese work is about ten times longer.

The tongue switch exhibited has been specially designed to prevent the tongue flipping during the passage of cars, by holding it in place by a simple lever arrangement.

The class 60 bogie truck which has been recently adopted as a standard by the Montreal Street Railway for their passenger cars is the result of continued efforts on the part of the Montreal Steel Works to produce a truck which would combine the most desirable features already in existence, and eliminate the defects and weak points of all trucks. The easy riding of the new cars recently put into service by the Montreal Street Railway is due to the great care taken in the design of the springs used in the construction of the trucks. A number of special features are introduced, including a simple but effective anti-chattering device, which automatically takes up all wear on the brake hangers eliminating the noise and chattering usually experienced when the car is brought to a standstill.

## Conveying Apparatus in Paper and Pulp Mills

Routing of material is an important feature in every manufacturing establishment. To gain the greatest economy involves a special problem for almost every class of manufacture, the end in view being, always, economy, with which is associated speed of operation and facility of handling. The problem is one that has called for a great deal of thought and consideration on the part

competition, rendered this problem of prime importance, and each step towards a satisfactory solution was carefully watched. Conveying machinery of the scraper type was first employed, but was found unsatisfactory because of the following reasons:

First—Small capacity because of slow speed.

Second—Breakdowns, rendered frequent

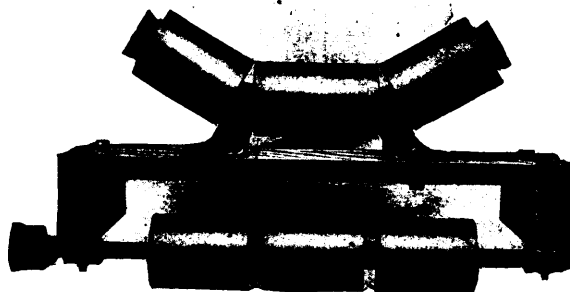

FIG. 1—ROBINS TROUGHING IDLERS.

of superintendents and works engineers and manufacturing companies devoted to such lines, resulting in the designing and building of a great variety of special apparatus to fill the various requirements.

The economical handling of material in pulp and paper mills was a problem which occupied the attention of mill owners and manufacturers of labor saving machinery for a great many years. Increased output caused by greater demand, together with keen

by the constant wearing out of the many metal parts in its construction.

Third—Enormous power required to operate because of great amount of friction between scrapers and trough.

Light, cheap belt conveyors of the kind most commonly found in grain elevators were next used, but on account of their very lightness and cheapness were not a great success, although a distinct improvement over the scraper conveyor,

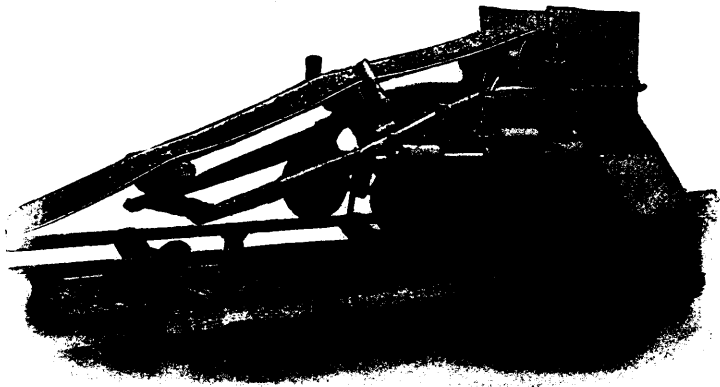

FIG. 2—THE ROBINS AUTOMATIC SELF-REVERSING TRIPPER.

It will be noted that the first change in the material handling equipment of paper mills was one of type. The second and perhaps the more important change was one of design, which change was effected by Robins conveying and elevating machinery. In the Robins belt conveyor capacity and low power requirements are combined with durability and simplicity. The fundamental principle on which the Robins belt conveyor is based is the perfect separation of the conveying from the running parts. The material carried is received directly on the troughed belt and is conveyed with minimum friction to its destination.

The Robins patent belt is constructed so that the centre of the carrying surface is protected by an extra thick rubber cover. The edges are stiffened by running in two or more extra plies of duck a part way towards the centre. This special construction reinforces the point subjected to greatest wear and also causes the belt to trough of its own weight, consequently following the lines of its support without strain.

The idlers which support the loaded belt are made of three or more cast iron or pressed steel pulleys mounted on hollow steel shafts

which in turn are held in cast iron brackets. One of the forms in which the Robins troughing idlers are made is shown in Fig. 1. The illustration also shows the return idlers used for supporting the returning empty belt. Lubrication is accomplished by forcing grease from compression cups through apertures in the hollow shafts, the grease forming collars which absolutely exclude dirt or grit from the bearings.

The Robins automatic self-reversing tripper shown in Fig. 2 is used in pulp and paper mills for discharging chips and other material to storage. This tripper requires no attendance and by its use uniform storage is assured.

The improvement made during recent years in machinery for paper mills is well shown by the equipment of the modern mill of the



FIG. 4—TWENTY-THREE INCH BELT, 143 FT. LONG.



FIG. 3—DELIVERING CHIPS TO STORAGE ABOVE DIGESTERS.

Cherry River Paper Co., at Richwood, West Virginia.

The system consists of four Robins belt conveyors and one Robins bucket elevator. Two chippers of large capacity feed a 20-inch belt conveyor 44 feet long, which discharges to screens. The bark and refuse are then taken by a second conveyor to the fire room, a third conveyor carrying the chips to the boot of the chain and bucket elevator. This elevator discharges to a fourth conveyor 20 inches wide and 65 feet between centres, which delivers the chips to storage above the digesters, by means of a Robins automatic self-reversing tripper. Fig. 3 shows the last mentioned conveyor.

Wood chips are extremely light and alone would not suffice to trough the belt of a conveyor. Failure to trough would cause a considerable decrease in capacity, since it would practically result in the formation of a flat conveyor, which has but a third the capacity of a troughed conveyor of the same width. Great quantities of the material would also be spilled before the proper discharge point was reached. The Robins patent belt, however, troughs naturally because of its special construction, hence this trouble is obviated where these are used.

Fig. 4 shows a Robins belt conveyor in





FIG. 5—ANOTHER ILLUSTRATION OF BELT CONVEYOR TAKING CHIPS TO STORAGE.

operation in a mill. This belt is equipped with an automatic self reversing tripper which discharges the chips to storage.

Another illustration is given in Fig. 5

showing a belt conveyor taking chips to storage. This belt discharges chips to storage by an automatic self reversing tripper and is 16 inches wide and 175 feet long.

## New Automatic Gas Engine

GOLDIE & McCULLOCH CO., GALT, ONT., MANUFACTURING A NEW TYPE OF DOUBLE-ACTING TANDEM AUTOMATIC GAS ENGINES.

Recently the Goldie & McCulloch Co., of Galt, Ont., entered a new field of manufacturing activity, having commenced the manufacture of gas engines. They have adopted the type originally designed by J. Thompson & Sons Mfg. Co., Beloit, Wis., and are now manufacturing 160 h.p. double acting tandem engines of this type but with some alterations designed by their chief

end to end, the two pistons being connected by one rod made of the best high carbon open hearth steel. The pistons are of the usual trunk type, of proper length to insure smooth running. The piston rod is secured to the piston in such a way as to be easily uncoupled, and either piston may be removed without interfering with the other. The rod is fastened by brass nuts protected by suit-

mechanical takeups. The connections can very easily be taken apart and the adjustments very easily made.

The governor used on this engine is of the Rites inertia type, with special features of application to gas engine practice. The governor is instantaneous in its action and is never at rest; it is always seeking its proper centre of gyration. The method of transmitting the movement of the governor to the valve gear is novel, simple and positive. The automatic cut-off valve is actuated by the governor through a pair of compensating gears, located on the cam shaft, thus advancing or retarding the point of the cut-off.

The automatic cut-off valve is located in the in-take valve chest on top of each cylinder, and consists of a bronze cylindrical sleeve working in a bored and ground casing. Ports are of sufficient area to admit full charge of mixture, and will cut-off at any point of the piston travel according to the load on the engine. This construction does away with the objectionable feature of wire drawing the charge common to all throttling governor engines.

The valves are of the vertical poppet type, of large areas. The inlet valve is placed on top of each cylinder, and the exhaust valve directly opposite, underneath each cylinder, thus doing away with all pockets and ports to the cylinders. These valves are all actuated by a simple mechanism, conveying the motion from the cam shaft in such a manner as to give a direct up and down movement to the valve stems, thereby producing no side wear to the valve stems. All valve chests are properly water jacketed.

The water jackets of each cylinder, each valve chest, and the intermediate head, which forms also the piston rod packing cham-

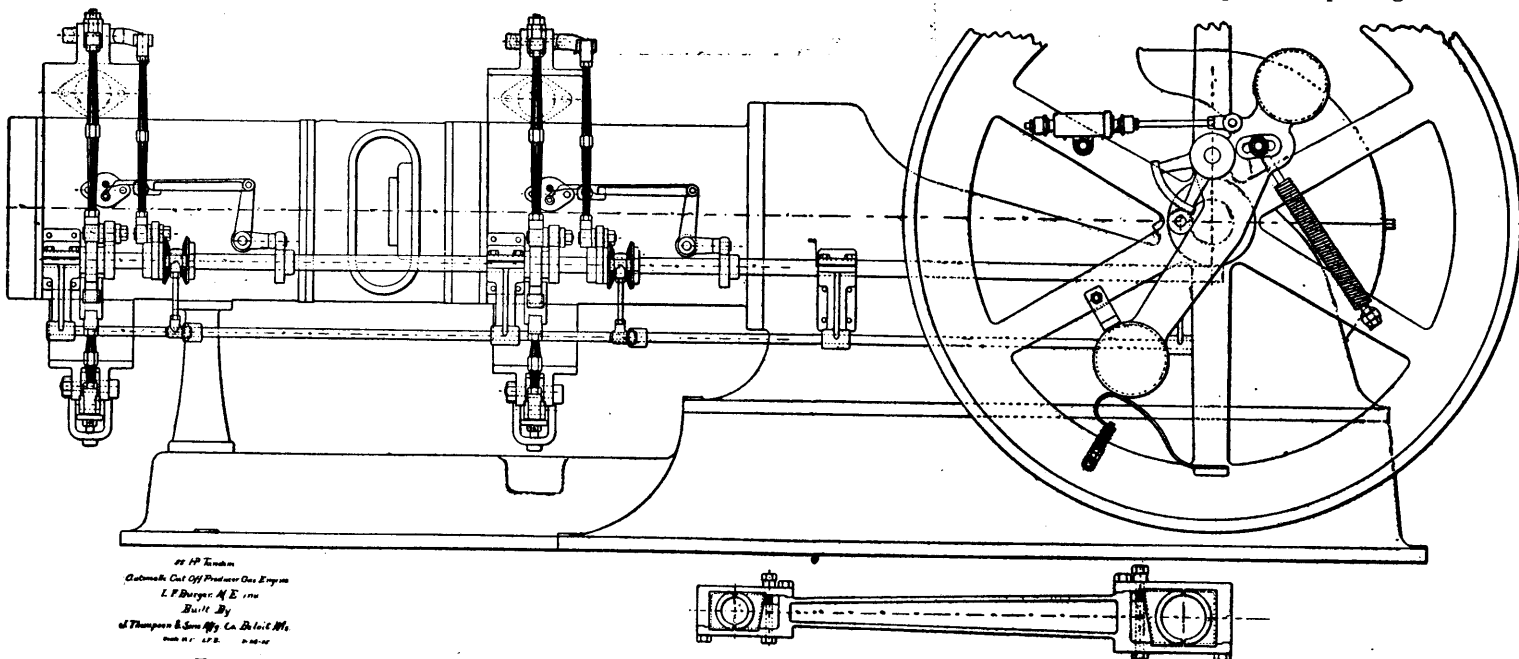

FIG. 1—CROSS SECTION OF 55 H.P. TANDEM, AUTOMATIC CUT-OFF, SHOWING VALVE GEAR AND RITES INERTIA GOVERNOR.

engineer, Mr. Arthur Spotton. They are tandem cylinder engines, four cycles, double acting. It is intended in the near future to manufacture other sizes and take up the manufacture of gas engines on an extensive scale.

The tandem arrangement is shown in Figs. 1 and 2, illustrating the single acting type. The two cylinders are placed horizontally

able caps or coverings from the heat of the gases. The front piston is coupled to the connecting rod close to the outer end of the piston so as to prevent any rocking or tilting motion. The pistons are provided with five packing rings each.

The connecting rod is of the well known box pattern, of special design, thus insuring an absolutely safe connection with approved

ber, are all separate and independent, thereby doing away with all water packed joints, and cooling of each cylinder can be regulated at will.

The piston rod packing consists of two separate and complete sets of packing and are made of a special alloy, guaranteed to withstand 1,400 degrees of heat. They are cut into segments of three to the circle to

overcome expansion and contraction due to heat. These sections are fitted into a conical cup and forced down and held in place by a compression spring. These cups are free to move within the cup chamber so as to allow

worn out and no adjustments are required. When necessary they can easily be renewed. The electric igniters are of the well known hammer break type, inserted into the side of each cylinder and are easy of access. The

Packed at the inner end of the igniter chamber, thus not exposing the igniter plugs to the extreme heat of the gases and making it always easy to take them out. The bed is massive and is designed on such

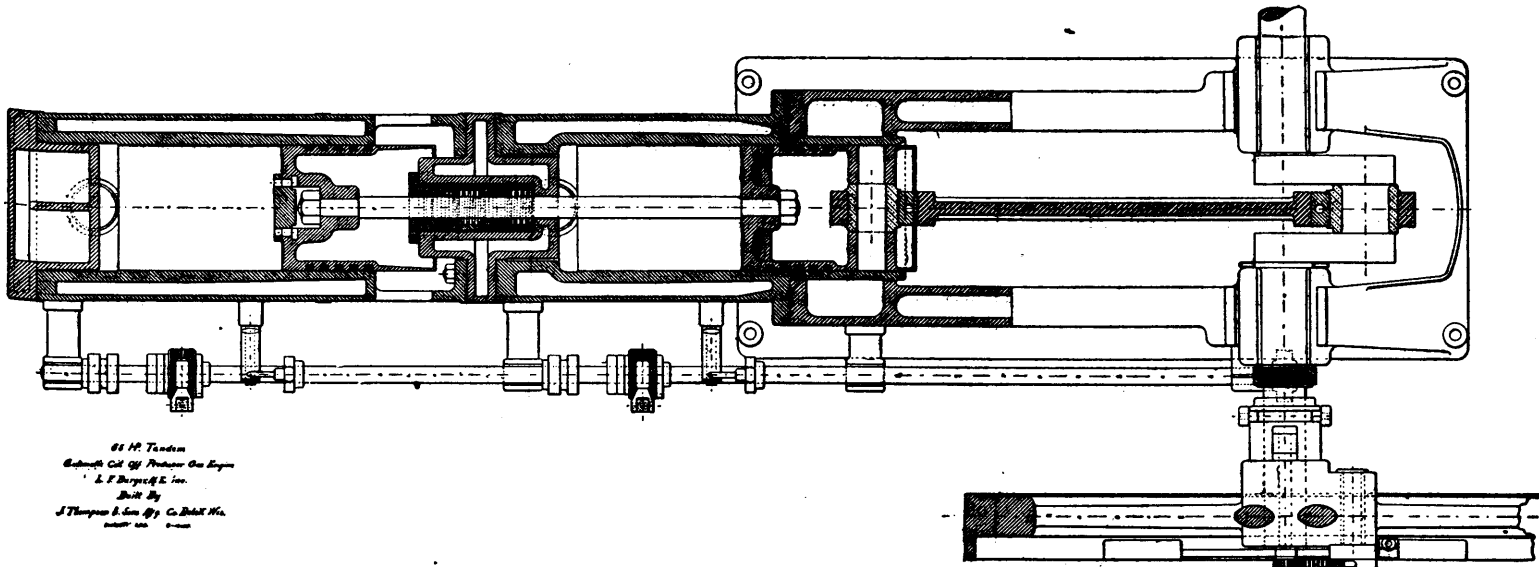
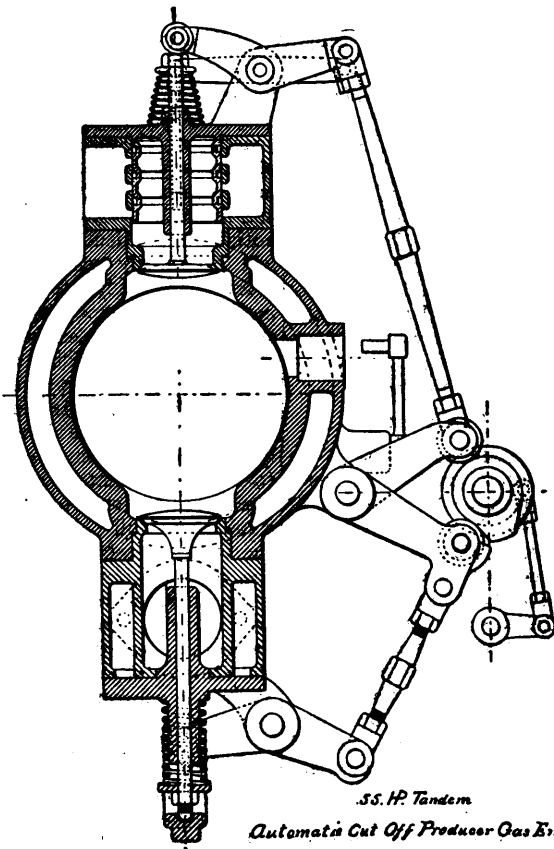

FIG. 2—CROSS SECTION OF 55 H.P. TANDEM AUTOMATIC CUT-OFF SHOWING CYLINDER ARRANGEMENT AND PISTON ROD PACKINGS.

for any possible down wear or vibration of the pistons and rod, and always insure a tight joint. These cups are all ground and faced on the end so that they may rub or slide in any direction without leaking. The packings will continue to wear until completely

points are just inside of the combustion chamber where there is no possible danger of fouling. An extra igniter for each cylinder is furnished. The igniters can be easily timed while the engine is running to secure the best possible results. The igniters are

lines as to secure the maximum amount of strength, and the metal is so distributed as to equalize and withstand all strains to which it is subjected. There is no dead weight of useless metal. The main bearings are of ample size, babbitted with the highest grade of iridium bronze. The bearing caps are carefully fitted and held in place by removable bolts. The end of the bed is faced and bored at one end to receive the cylinders, thus bringing all working parts into perfect alignment. The sub-bed is made with an extension to support the outer cylinder, allowing plenty of room to get at the working parts of the engine.



55 H.P. Tandem  
Automatic Cut Off Producer Gas Engine  
L.F. Burger M.E. inv.  
Built By  
J. Thompson & Sons Mfg. Co. Beloit Wis.  
122 6-20-07

FIG. 3—CROSS SECTION OF CYLINDERS AND VALVE GEAR SHOWING AUTOMATIC CUT-OFF VALVE.

The cylinder and piston rod packings are oiled by a force feed pump adapted to regulate the proper amount of oil. The main bearings and wrist pin are oiled from a reservoir placed on top of the crank shield and arranged with sight feeds adapted for continuous running.

One exhaust pot or muffler is furnished with each engine, and is arranged to receive the waste water from the engine and reduce the sound of the exhaust to a minimum.

The engine is furnished with an automatic starting device consisting of an air pressure tank and a suitable valve mechanism.

The Bristol Co., Waterbury, Conn., are about to erect a large addition to their present plant. It will be 170 x 53 feet, three stories high. This additional space is made necessary by the increased demand for Bristol's recorders and steel belt lacing. At the present rate of increase of business it is anticipated that the additional space will soon be taxed to its full capacity.

A large force of men are engaged in laying underground cables of the Bell Telephone at Peterborough, Ont.

A. C. Lyons & Co., Brantford, Ont., are installing a lighting plant in the new factory of the Gillson Co., Guelph, Ont.

H. Weineberg, Toronto, will erect a large store on the corner of Yonge and Edward streets at a cost of about \$30,000.

# Efflorescence (Whitewash) of Brick.

FROM PAPER BY J. C. JONES, CHAMPAIGN, ILL., IN BULLETIN SENT OUT BY UNIVERSITY OF ILLINOIS.

During the reign of Napoleon III. of France, while a large part of Paris was being rebuilt, the walls of the new buildings became coated with unsightly splotches of a white crystalline substance known as efflorescence, or whitewash. The cause and cure of the phenomena so baffled the scientists of that time that the emperor offered a reward of \$100,000 to any one who would discover a means of preventing its occurrence. Many of the prominent scientists of Europe at once investigated the problem, but beyond determining the composition of the efflorescence little was accomplished. (Brick, vol. VI., p. 195). In our own country the first published notice of efflorescence appeared about the year 1882, at which time there was an unusual amount of it on buildings, both here and abroad. It appeared not only on buildings under construction, but also on those never known to be troubled before.

Among the several scientific societies which took up this problem was the Academy of Natural Sciences of Philadelphia. They reached the conclusion that the cause of the trouble was principally magnesium carbonate. Many of the recent writers mention that the efflorescence was supposed to be nitre of saltpeter, evidently because it resembled the deposit which appears on stable walls which have manure and other refuse piled against them. Seger seems to have been the earliest of the ceramists to have studied this problem, and he demonstrated that the efflorescence is not saltpeter, but rather, that it is generally sulfate of the alkalies or alkaline earths. Seger was followed by several other German investigators, among whom Hans Guenther seems to stand foremost. Guenther laid particular emphasis on the role that pyrite plays as well as on the reactions that take place between the salts in the brick and mortar. In our own country, Dr. Otto Gerlach clearly stated the possible reaction of the lime in the brick with the sulphur in the kiln gases that cause the formation of soluble sulphates.

In spite of this work that has been done, the entire cause and prevention has not been found. Efflorescence is as abundant as ever and can be found on new and old buildings alike. What has been done, however, has been a great step in advance, and by far the greater part of the unsightly stains on our buildings can be done away with if brick manufacturers and builders take the precautions already determined. Each investigator has laid particular emphasis on the particular cause he has been investigating, leaving the impression that it was the cause of all efflorescence. The fact is, there are a number of causes for the trouble, and a number of precautions to take. It is the purpose of this paper to gather together as far as possible all of the causes and means of prevention known to the writer in the hope that it may aid those who are endeavoring to overcome these unsightly stains on our brick.

## EFFECT OF EFFLORESCENCE.

It has been stated that crystallization of salts on the surface of brick would have the same disintegrating effect as the formation

of the ice crystals and cause the brick to weather so much more rapidly.\*

On the other hand it has been suggested that efflorescence is of benefit to the brick when it is burned because it concentrates the fluxing material, calcium, etc., near the surface of the brick. It was observed that the whitewashed bricks were the better vitrified. This is, however, an open question.

While efflorescence may or may not harm the brick in a mechanical way, it certainly does harm the appearance, and means an actual monetary loss when the appearance of the brick is part of its intrinsic value as in a face brick.

## KINDS OF EFFLORESCENCE.

For convenience in discussing the sources and causes of efflorescence it is best to divide it into two classes, first, that which appears on the brick in the kiln or kiln white, and, second, that which appears afterwards or wall white. The kiln white is burned into and is a part of the brick, while the wall white is powdery and can be rubbed off. Kiln white is often subdivided into dryer white, or that which originates in the dryer, and kiln white, or that which originates in the kiln. While this distinction is often convenient in assigning the cause of a whitewash on the brick, yet it is often impossible to distinguish between the two without experimenting. In general, however, dryer white is almost always brought to the surface of the brick through the evaporation of the water and so appears in small pimply crystals, while the kiln white is most often caused by the reaction of the kiln gases and the lime in the brick and appears as fluffy clusters. This is not a sure means of distinguishing the kiln and dryer whites, as kiln white may also come from evaporating water, and the dryer white may also be formed, in case of a waste heat dryer, by the reaction between the sulphur in gases and the lime in the clay. For the purpose of this paper I shall not distinguish between kiln and dryer white, as they are identical in origin and composition.

## COMPOSITION OF KILN WHITE.

Analyses of kiln white shows it to be almost entirely calcium sulphate with small amounts of magnesium and alkaline sulphates and occasionally alum.

In order to form some idea of the relative power of the various salts to cause efflorescence a series of trials was made containing 0.5 gram each of sulphates of calcium, magnesium, and aluminum, the carbonates of calcium and sodium, and chloride of sodium. These salts were added to 100 grms. of clay that had been previously washed thoroughly, the mass formed into brickettes, and burned under oxidizing conditions. The sulphates caused by far the greater amount of efflorescence, the alum coating the trial entirely, the others covering the sides. The carbonates gave a thin coating of efflorescence, the sodium much the heavier of the two, and the sodium chloride simply discolored the trial, making it a little darker. From this it was seen that the sulphates were the most dan-

gerous, but that any soluble salt is liable to cause trouble.

## SOURCES OF KILN WHITE.

The sources of the kiln white salts may be said to be in the clay, in the water used in manufacture, or in the kiln gases, or perhaps in many cases all three of the sources named.

## EFFLORESCENCE FROM THE CLAY.

Practically all brick clays contain or have contained sulphur in the form of iron pyrites. When the clay is exposed to the action of the air and its weathering influence, which action extends to the permanent water line, iron sulphide or pyrite oxidizes to iron sulphate.

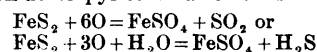

The iron sulphate alters with the further addition of water and oxygen to limonite, setting free the sulphur as sulphuric acid.

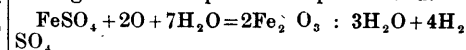

This sulphuric acid then enters into solution and reacts with the calcium, magnesium, aluminum, and other bases originally in the form of carbonates, silicates and chlorides, and forms sulphates as gypsum, alum, etc.

Again, the iron sulphate may react directly with the calcium carbonate, which is nearly always present, and form iron carbonate and gypsum.

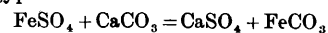

As the iron in an unoxidized clay is usually in the form of either the sulphide or carbonate, and since gypsum is also a common constituent, the reaction between the sulphate of iron and carbonate of lime is probably more common than that of mere oxidation and hydration. Both reactions are, however, initially oxidation. From the foregoing it will be readily seen that the amount of whitewashing sulphates formed in a clay depends directly upon the extent to which the clay has been exposed to oxidizing influences. The oxidizing zone in the earth's surface extends down to the permanent water level. In this zone the process of oxidation is at its maximum, and consequently the changes from the insoluble sulphides to soluble sulphates takes place here most rapidly. The sulphates, once formed, are soluble and will be removed by solution by the water percolating through the clay. As the clays are, as a rule, very compact and impervious, the water circulates through them very slowly. Consequently until the clay has been opened up by the action of frost and the roots of vegetation and made more pervious, the sulphates are not removed to any appreciable extent.

When soluble sulphates are present in the clay they appear on the surface of the green brick as it is drying. They may be concealed, in fact generally are, by the similarity of their color and that of the brick, but as the brick is burned the sulphates stand out as white specks on a darker background and the whitewash is brought out apparently in the kiln. Since the evaporation of the water contained in the green brick can only take place at the surface the water of the interior must come to the surface through the action of capil-

\* (Orton. Role played by iron in the burning of clay wares. Transaction Cer. Soc., Vol. 5, p. 398).

# WHAT'S IN A NAME?

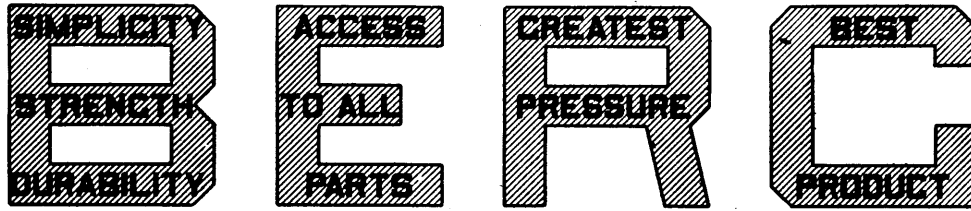

The "Berg Press" is The Highest Development in the Art of Brick-making Machinery, so Pronounced by the U.S. Government.



THE BERG PRESS EXCELS  
for  
Shale Pressed Brick.  
Clay Pressed Brick.  
Sand-Lime Pressed Brick.  
Sand-Cement Pressed Brick.  
Fire Brick.

THE BERG PRESS  
Gives THREE Distinct PRESSURES :  
Result is,  
No Granulated Centers.

THE BERG PRESS  
HAS ALL WORKING PARTS ABOVE  
Clay Line.

THE BERG PRESS  
is fitted with "THE BERG PATENTED  
MOLD Box"—the DELIGHT of brick-  
makers, and which many OTHERS  
have tried to IMITATE.

All Sizes and Shapes  
Can be Made.  
Molds Can be Changed in a  
Few Minutes,  
Owing to the  
SIMPLE  
MECHANICAL  
CONSTRUCTION.

### Improved Berg Brick Press.

Cut Gearing, and many other steps forward in Improvements, and built of the Highest Grade of Material and Workmanship. Fully Guaranteed as to its Success.

Manufactured by its inventor in Toronto, Canada, exclusively. Also all equipments for Pressed Brick Plants to make Sand-Lime Brick, Sand-Cement Brick, Shale Brick, Clay Brick and Fire Brick. Correspondence solicited.

**A. BERG & SONS,** Manning Chambers,  
TORONTO, CANADA

larity. The soluble salts are brought out in solution by the water and the water evaporating leaves the salts concentrated on the surface. Perhaps I can make this clearer by an actual case. A clay whitewashed and by experiment it was found that the trouble lay in the soluble salts of the clay. Analyses of the clay showed 0.75 per cent. sulphur trioxide, of which 8.92 per cent., or 0.065 per cent., in terms of the clay, was soluble. Analysis of the face of the dried brick gave 1.30 per cent. of sulphur trioxide, of which 40.77 per cent., or 0.56 per cent. in terms of the clay, was soluble. The gain in sulphur by the face of the brick will be readily seen to be entirely of the soluble form. In other words, the soluble salts had been collected on the face of the brick by the process of drying. It is also interesting to note the very small amount of sulphur trioxide, only 0.65 per cent., about 7.95 gram, or 0.07 of an ounce per brick that it takes to cause decided efflorescence.

As before stated, nearly all the shales and fire clays contain iron pyrites. That part of it which escapes the action of the weather enters into the brick in its original form. Although it does not cause either kiln or dryer white, it is a very large source of the wall white and it is simplest to consider it at this point. Pyrite is peculiar in the fact that it will part with one molecule of its sulphur quite readily at the comparatively low heat of 400 degrees C., but holds tenaciously to the other until at least 900 degrees C. In fact, there seems to be good reason to believe that it is not driven off at all except under good oxidizing conditions.\*

The first molecule of sulphur, however, is set free at a time when there is an abundance of water and oxygen in the kiln gases, and as it passes the lime and magnesium carbonates in the clay it combines with them to form sulphates. These, once formed, are not decomposable under ordinary conditions and remain unnoticed in the brick until they are laid in the wall. Then, due to the leaching action of the rains and the water passing through the wall from the water pipes, gutters, and foundation, they appear as efflorescence.

#### EFFLORESCENCE FROM KILN GASES.

The sulphates in the clay are not the only cause of whitewash, however. Calcium carbonate is nearly always present in the clay, often in large quantities, and occasionally magnesium. As these are comparatively insoluble, they are not carried to the face of the brick to any extent during dryness, and consequently do not form a large part of the kiln white. If, however, they lie at the surface, especially if in the form of pebbles, they are almost certain to form kiln white by reaction with the sulphur dioxide of the kiln gases, while that which lies in the interior, reacting with the kiln gases, forms the sulphates which come out later as wall white.

Guenther was the first to prove this in a positive manner. He burned feldspar, kaolin, and marl at a red heat in a furnace with sulphurous fumes present and found that while the feldspar was unaffected, the kaolin and marl were attacked with the formation of calcium, sodium, and other sulphates. Further, with mixtures of clay and chalk the efflorescence increased with the increase of the lime.

\* (Orton. Role played by iron in the burning of clay wares. *Transaction Cer. Soc.*, Vol. 5, p. 398).

Gerlach, in somewhat similar experiments, found that:

1. In clay containing pyrite and calcite burned in a flame free from sulphur the amount of sulphates was increased five times.
2. When both clay and fuel contained sulphur the increase in sulphates was 20 fold.
3. When the clay contained calcite and the fuel sulphur the increase in sulphates was 40 fold.
4. When clay and fuel were both free from pyrite, there was but slight increase.
5. When the clay contained a large amount of pyrite but no calcite, and the fuel was free from sulphur, there was but slight increase.
6. When both fuel and clay contained pyrite but no calcite, there was but a slight increase.

From these experiments it can be readily seen what an important role the calcite in the clay and the sulphur in the fuel play in the formation of the efflorescence.

The coal burned in kilns, especially bituminous coal, contains sulphur in the form of iron pyrites or marcasite, as well as free sulphur. This is generally easily seen in the coal as bright specks or seams and is commonly known as sulphur. When the coal is burned, the iron sulphide is oxidized and

## THE FIFTH ANNUAL C. C. P. M. CONVENTION

The Fifth Annual Convention of the Canadian Clay Products Manufacturers will be held in Ottawa on Tuesday, Wednesday and Thursday, November 19, 20 and 21. The officers of the Association are sparing no efforts to make this convention one of the most successful ever held.

sulphur dioxide, a gas, results. This passes through the kiln with the other gases. Seger\* tried the experiment of condensing the water vapor in the gases of a burning kiln and an analysis showed considerable amount of sulphuric acid and some hydrochloric acid. As most chlorides are quite volatile, it is probable that the hydrochloric acid does not play any large part in the formation of whitewash, but passes out into the open air. The sulphuric acid, on the other hand, reacts with the carbonates and other calcium salts to form sulphates which are stable under all kiln conditions except a reducing fire. Thus it is possible that a clay that did not originally contain any sulphates could show whitewash, and in fact the work of Guenther and Gerlach has shown that this is a very fruitful cause.

It is an often observed fact that the bricks in the colder parts of the kiln show whitewash when the rest of the ware is free from it. This can be explained by the fact that the bricks in the warmer parts of the kiln begin to give up their water before the other brick have become heated. These colder brick then would condense this water vapor containing sulphuric acid from the kiln gases and absorb it. The absorbed acid acts on

the lime, etc., forming sulphates which are left on the surface of the brick.

Again it is a fact that a brick set wet will whitewash. This can be explained by the absorption of the sulphurous gas by the water in the brick and as the acid will penetrate all parts of the brick through diffusion, sulphates will form and be carried to the surface of the brick as it dries out. There are probably other salts, chlorides, nitrates, etc., which occur in minute quantities that contribute their share to the trouble, but they are very rarely present in large enough quantities to cut any figure.

#### EFFLORESCENCE FROM THE WATER.

The water used is generally drawn from wells or streams and always contains salts dissolved in it. These are principally calcium and magnesium carbonates, sodium sulphate and other chlorides, phosphates, and nitrates. As a rule these do not amount to more than from .02 per cent. to .05 per cent. and since there is only approximately 800 grams of water used in each brick, this would introduce only 0.4 gram of salt, an amount entirely too small to cause trouble. If the salts rise much about 0.05 per cent. the water may be an important factor in causing efflorescence, since the principal salts, calcium and magnesium carbonates, combine with the sulphurous fumes of the kiln gases as has been explained before.

[Conclusion of this article will deal with "Means of Prevention of Whitewash in Brick."]—Ed.

#### ROLLING MILLS BUSY.

The Manitoba Rolling Mill Co., of Winnipeg, is the latest firm in Canada to erect and operate a rolling mill. The plant was completed in the early summer and active operations commenced about July 1. The premises include about six acres of land in the vicinity of the Canadian Pacific Railway shops, with proper sidings and shipping facilities. The equipment of the mill includes one nine inch rolling main and one 16 inch with necessary furnaces, boilers, steam engines, etc. The plant has a capacity of about 40 tons a day. Although an independent company the controlling interests are the same as those of the United States Horse Shoe Co. of Erie, Penn., where they have a large plant employing 400 men. It is the intention eventually to put in horse shoe machinery as well as apparatus for making bolts, nuts and spikes. The same interests control a blast furnace in Erie, which produces 400 tons a day. The officers of the company are: L. A. McElroy, president; T. M. Kirkwood, vice-president; B. S. Fletcher, secretary; and J. S. Curtis, treasurer.

The United Fire Brick Co., of Uniontown, Pa., has been formed by the amalgamation of the Dunbar Fire Brick Co., and the Fayette Fire Brick Co. with their general office in the First National Bank Building, Uniontown, Pa., and Pittsburg office in Room 1601, Arrott Bldg. While the new company has purchased the several plants, equipments and properties the management of the different plants will continue as heretofore, but customers will have the advantage of increased facilities.

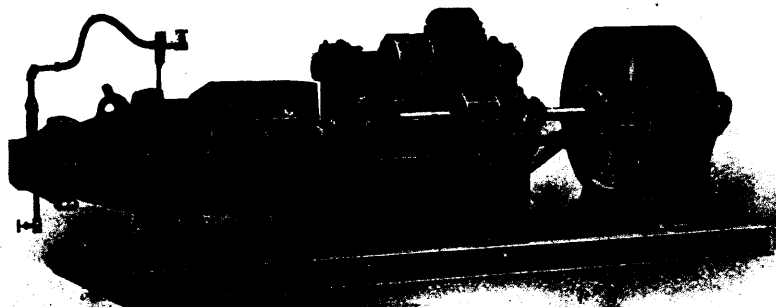

## No. 555 BRICK MACHINE

This machine embodies the best ideas in the construction of Brick Machinery. Its capacity is large, only a question of the power you put behind. Without doubt this is the *STRONGEST* and *MOST SERVICEABLE BRICK MACHINE BUILT IN THE DOMINION*. It is also adapted to the manufacture of tile, fire proofing, conduits, and hollow blocks.

*We install COMPLETE CLAY WORKING PLANTS. Let us send you our NEW CATALOGUE*

**BECHTELS, LIMITED, Waterloo, Ont., Can.**

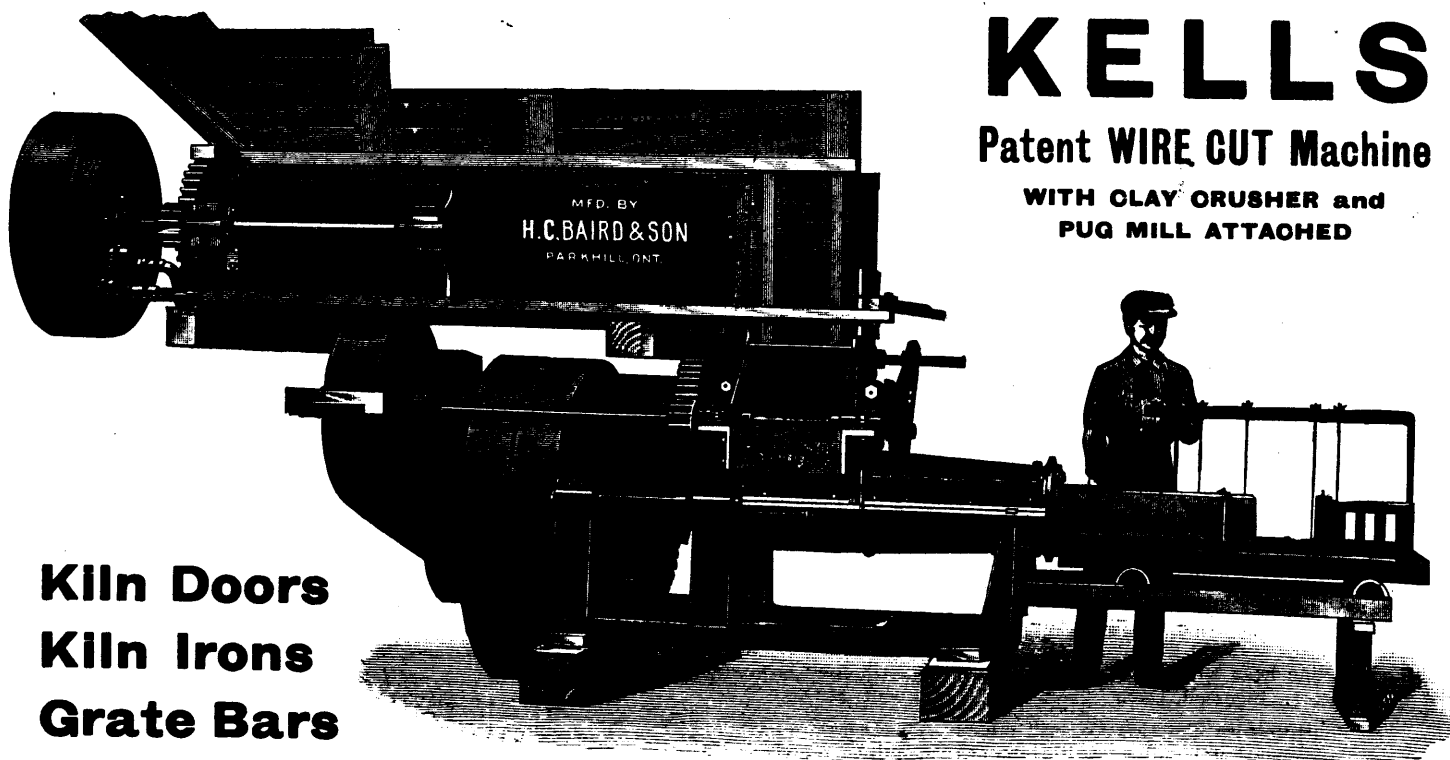

# KELLS

Patent WIRE CUT Machine

WITH CLAY CRUSHER and PUG MILL ATTACHED

**Kiln Doors  
Kiln Irons  
Grate Bars**

FULL LINE OF BRICK AND TILE MAKING MACHINERY AND YARD SUPPLIES OF ALL KINDS

**H. C. BAIRD, SON & CO., Limited, Parkhill, Ont.**

When writing to Advertisers kindly mention THE CANADIAN MANUFACTURER.

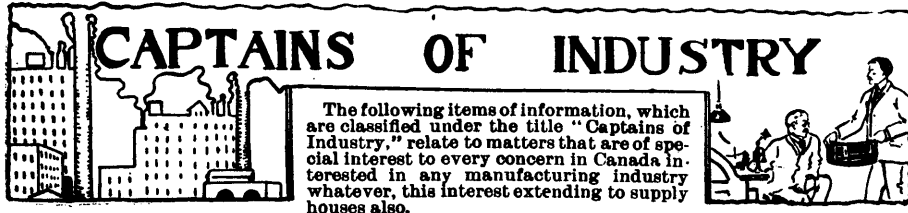

The Toronto Yarn Spinning Co., Toronto, have been incorporated with a capital of \$100,000, to manufacture woolen, worsted, cotton yarns, etc. The provisional directors include J. A. Murray, J. P. Murray and F. B. Hayes, Toronto.

Work has commenced on the new Collegiate Institute to be erected at Picton, Ont., at a cost of about \$100,000.

When completed the addition to the shops of the Grand Trunk Railway Co., London, Ont., will cost about \$60,000.

The Delaplante Lumber Co., Toronto, have been incorporated with a capital of \$400,000, to manufacture lumber, timber, etc. The provisional directors include A. J. Delaplante, Buffalo, N.Y., C. W. Wilkinson and T. H. Kelly, Toronto.

The Spears Mining Corporation, Toronto, have been incorporated with a capital of \$50,000, to carry on a mining, milling and reduction business. The provisional directors include D. A. Rose, F. W. Rose and R. S. Gilpin, Toronto.

The Canadian Smelting & Refining Co., Toronto, have been incorporated with a capital of \$2,500,000, to carry on a smelting and refining business. The provisional directors include W. M. Wallace, A. G. Robertson and J. D. Pringle, Toronto.

Dunelin, Limited, Hamilton, Ont., have been incorporated with a capital of \$100,000, to carry on a navigation and transportation business. The provisional directors include R. O. MacKay, J. P. Steedman and G. Somerville, Hamilton.

Canadian Northern System Terminals, Toronto, have been incorporated with a capital of \$2,000,000, to construct oil tanks, pipe lines, steamboats, piers, docks, warehouses, factories, etc. The provisional directors include A. J. Mitchell, F. C. Annesley, and L. W. Mitchell, Toronto.

The Windsor Belt Dressing Co., Windsor, Ont., have been incorporated with a capital of \$40,000, to manufacture belt dressing, machinery supplies, etc. The provisional directors include W. H. Oakes, W. H. Bradt, and W. Richards, Windsor.

Parker's dye works, Peterboro, Ont., were destroyed by fire September 23. Loss, about \$7,000.

The Grand Valley Radial Co., Grand Valley, Ont., have prepared plans for the new line from Brantford to Port Dover, Ont. The company are also considering the erection of a line from Brantford to Woodstock, and thence to Ingersoll, Ont.

The Southwestern Traction Co. will erect a large summer hotel and a sanitarium at New Orchard Beach, Port Stanley, Ont.

The Georgian Bay Power Co. are developing power at Eugenia Falls, near Flesherton, Ont. They propose building a large dam about 40 rods above the falls and piping the river through a large hill to the Beaver Val-

ley. About 3,000 h.p. will be developed at first.

The new mint at Ottawa will commence operations in November and will turn out \$1,000,000 worth of coin a year, and save 50 per cent. to the country.

The Right-Process Co., Toronto, have been incorporated with a capacity of \$40,000, to manufacture washing compounds, etc. The provisional directors include A. H. Brother, W. McLean, and W. C. Ormsby, Barrie, Ont.

The Producers Natural Gas Co., Hamilton, Ont., have been incorporated with a capital of \$100,000, to manufacture oil, gas, ores, etc. The provisional directors include W. Southam, J. Milne and F. A. Magee, Hamilton.

The Chatham Carriage Co., Chatham, Ont., have been incorporated with a capital of \$100,000, to manufacture carriages, trucks, wagons, sleighs, automobiles, etc. The provisional directors include I. Teeter, A. Cooke, and F. E. Fisher, Chatham.

The Haileybury Brick & Tile Co., Haileybury, Ont., have been incorporated with a capital of \$50,000, to manufacture brick, tile, clay, etc. The provisional directors include A. J. Murphy, B. C. Beach, Haileybury, Ont., and D. McArthur, Kenmore, Ont.

The waterworks of St. Thomas, Ont., has just been increased by the fifteenth flowing well; it is expected to yield 200,000 gallons daily.

The Dominion Crown Cork Co., Toronto, have been incorporated with a capital of \$15,000, to manufacture crown corks, tin, wire, etc. The provisional directors include W. F. Hayes, A. B. Crosby, and G. Russell, Toronto.

The Bank of Nova Scotia will establish a branch at Brantford, Ont.

The council, Ingersoll, Ont., are applying to Andrew Carnegie for \$10,000 for a public library.

The Whitman & Barnes Co., St. Catharines, Ont., will enlarge their factory at a cost of about \$40,000.

The New Liskeard Concrete Co., New Liskeard, Ont., are installing a new mixer and a concrete block machine.

The city of Ottawa are considering the question of constructing a system of relief sewers in the Upper Town, at a cost of about \$28,000.

The Toronto Bolt & Forging Co., Swansea, Ont., will erect an additional plant at a cost of about \$30,000.

The Delaware Seamless Tube Co., Auburn, Pa., intend erecting a plant at Sarnia, Ont., at a cost of about \$200,000.

The Canada International Gas Co., Toronto, have been incorporated with a capital of \$5,000,000, to manufacture ores, metals, oil, gas, etc. The provisional directors include C. C. Blackwell, Toronto, J. T. O'Keefe,

Chatham, Ont., and E. M. Young, Picton, Ont.

The Toronto University will be extended at a cost of about \$2,000,000.

The large planing mill of W. M. Drader, Chatham, Ont., was destroyed by fire September 20. Loss about \$18,000.

The steamer "Picton" of the Richelieu & Ontario Navigation Co., was destroyed by fire at Toronto, September 20. Loss, including cargo, about \$100,000.

Wilbur Iron Ore Co., Toronto, have been incorporated with a capital of \$500,000, to carry on a mining, milling and reduction business. The provisional directors include C. L. Dunbar, H. C. Schofield and K. McKinnon, Guelph, Ont.

The Livingstone flax mill, Brussels, Ont., was destroyed by fire September 17.

The capital stock of the McLaughlin Carriage Co., Oshawa, Ont., has been increased from \$400,000 to \$1,500,000.

Zuelsdorf Bros., Berlin, Ont., will erect a factory there for the manufacture of all kinds of furniture.

The Dominion Mining Co., Ottawa, have been incorporated with a capital of \$150,000, to carry on a mining, milling and reduction business. The provisional directors include A. C. Budd, R. K. Milks and G. H. Ross, Ottawa.

The Peel Oil & Gas Co. have let contracts for the sinking of oil wells on their property at Cooksville, sixteen miles west of Toronto. This company have over 1,000 acres of land under option and it is expected that deposits of oil or natural gas will be encountered.

The Y.W.C.A. building, Simcoe Street, Toronto, is being improved at a cost of about \$12,000.

The Agauni Cobalt Mines, Limited, London, Ont., have been incorporated with a capital of \$600,000, to carry on a mining, milling and reduction business. The provisional directors include F. G. Rumball, A. B. Greer and A. Robinson, London, Ont.

The Canadian Steel Specialty Co., Gravenhurst, Ont., will erect a two story factory together with a boiler house and dry kiln, at a cost of about \$10,000. The company will manufacture steel furniture, electric fixtures and novelties.

The Masons of the Alpha Lodge, Toronto, will join with other lodges in the erection of a new hall to be built in the Northwestern part of the city, at a cost of about \$60,000.

The MacKay Bros., Limited, Renfrew, Ont., have been incorporated with a capital of \$50,000, to manufacture goods, wares, and merchandise. The provisional directors include J. MacKay, C. A. Dewey, and W. A. MacKay, Renfrew, Ont.

The new plant of the Chatham Gas Co., Chatham, Ont., has been completed.

The Fire and Water Committee, Hamilton, Ont., will shortly call for tenders for two 6,000,000 gallon electric pumps for the Beach pumping station.

The Department of Public Works, Ottawa, invite tenders up to October 10 for the construction of a dam across the Montreal River at Latchford, Ont.

K. L. Aitken, C.E., Toronto, recently made the official tests on the new eight hundred kilowatt plant at Morrisburg, Ont.

# Amatite

## ROOFING

Amatite is a ready roofing of superior durability with a mineral surface requiring no paint or coating.

There is the whole story of Amatite in a nutshell.

Its low price combined with the fact that it requires no paint makes Amatite the *most economical ready roofing on the market*. Other roofings require constant attention and care. Failure to paint regularly means a leaky roof. If you count the cost of this periodical painting and add it to the first cost of these roofings, the total makes Amatite seem cheap indeed.

The first cost of Amatite is the only cost. The first cost of the "paint-me-quick-or-I'll-leak" roofings is only the beginning.

There is nothing flimsy about Amatite. It is made to last. There is twice as much material in it as there is in most roofings—the weight of a roll tells that. It is easy to lay, requiring no skilled labor or special tools. Investigate the facts. They are in our new, free booklet. We send it free with sample of Amatite. Write at once.

### The Paterson Manufacturing Company, Limited

CANADIAN AGENTS

Toronto

Montreal

Winnipeg

St. John, N.B.

Halifax, N.S.

## "Herringbone" Lath and the Housing Problem

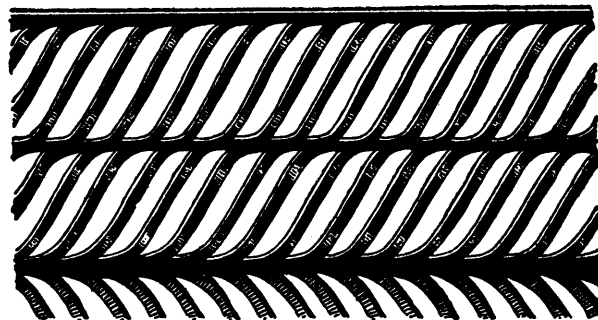

Almost everywhere in Canada there is a scarcity of houses. The high cost of building materials also keeps down the construction of new dwellings. With many manufacturers the "housing problem" has become a serious one. It is solved by

### "HERRINGBONE" LATH AND CEMENT SIDING

It's the cheapest DURABLE construction known.

Is fire-proof and everlasting—warm in winter, cool in summer.

Requires no painting, and is very handsome.

Is quickly erected and will take a variety of finish.

Write us for complete particulars.

**THE METAL SHINGLE & SIDING CO., Limited** - Preston, Ontario

MONTREAL, Cor. St. Catherine St. and Delorimier Ave.

TORONTO, 100 Esplanade St. East.



Brantford, Ont., will have an automatic telephone system working by the end of the year made by the Canadian Machine Telephone Co., of Canada.

The council, Belleville, Ont., will erect an isolation hospital at a cost of about \$15,000.

The Dominion Tool Co., Peterboro, Ont., have been incorporated with a capital of \$100,000, to manufacture augers, bits, gimlets, bolts, screws, rivets, etc. The provisional directors include W. R. G. Higgins, P. J. Creedon, and F. C. Cubitt, Peterboro, Ont.

The Gilmour Mining Co., Belleville, Ont., have been incorporated with a capital of \$300,000, to carry on a mining, milling and reduction business. The provisional directors include F. Landenberger, W. Carnew, Belleville, Ont., and L. P. Smith, Syracuse, N.Y.

The Plantagenet Woolen Mills Co., Plantagenet, Ont., have been incorporated with a capital of \$20,000, to manufacture woolen and textile goods, etc. The provisional directors include T. A. VanBridger, A. A. Fraser, and D. M. Viau, Plantagenet, Ont.

The Lovering Lumber Co., Toronto, have been incorporated with a capital of \$100,000, to manufacture lumber, timber, etc. The provisional directors include J. F. Hollis, T. H. Wilson and W. J. Lovering, Toronto.

The Standard Contracting Co., Toronto, have been incorporated with a capital of \$40,000, to carry on a foundry and machine shop and contracting business. The provisional directors include C. A. Campbell, J. W. DuLaney and S. Campbell, Toronto.

A waterworks system will be installed in Notre Dame de Quebec, Que., at a cost of about \$100,000.

Waterworks and electric light systems will be installed in Summerlea, Que.

The Standard Metal Mfg. Co., Montreal, have been incorporated with a capital of \$18,000, to manufacture steel castors, knobs, handles, hinges, anti-friction boxes, bearings, etc. The charter members include F. G. Robinson, H. W. Cooper and H. S. Vipond, Montreal.

Wm. G. Hartranft Cement Co., Montreal, have been incorporated with a capital of \$25,000, to manufacture cement, lime, plaster, etc. The charter members include L. Macfarlane, C. A. Pope and A. Swindlehurst, Montreal.

S. B. Townsend, Limited, Montreal, have been incorporated with a capital of \$200,000, to carry on a brewing and malting business. The charter members include G. L. Alexander, W. J. White and A. W. P. Buchanan, Montreal.

The Montreal Tobacco Co., St. Cesaire, Que., have been incorporated with a capital of \$20,000, to manufacture tobacco, cigars, etc. The provisional directors include P. Leclaire, C. Grise, St. Cesaire, Que., and H. Lamontagne, Montreal.

The Canadian Thermos Bottle Co., Montreal, have been incorporated with a capital of \$300,000, to manufacture bottles, glass, metals, etc. The charter members include L. Macfarlane, J. B. Schwabacher and C. A. Pope, Montreal.

The Ideal Smoke Consumer Co., Montreal, have been incorporated with a capital of

\$49,000, to install smoke consumers and accessories to same. The charter members include P. Bernard, Longue Point, Que., J. A. O. Labadie and O. Papineau, Montreal.

The Calkins Tile & Mosaic Co., Montreal, have been incorporated with a capital of \$20,000, to manufacture marble, tile, mosaic, granite, slate, plaster, concrete, limestone, terra cotta, etc. The charter members include A. L. Smith, A. C. Calder, J. W. Graham, Montreal.

The Montreal Engineering Co., Montreal, have been incorporated with a capital of \$100,000, to carry on the business of electrical and mechanical engineers, contractors, etc. The charter members include F. C. Clarke, C. C. Giles, H. A. Porter, Montreal.

The Lyster Drug Co., Montreal, have been incorporated with a capital of \$5,000, to manufacture drugs, chemicals, physicians' supplies, etc. The charter members include M. Aronson, A. M. Larose and W. A. Lortie, Montreal.

The Albert sawmills, owned by Messrs. Calhouns, Calhoun, N.B., were destroyed by fire, September 18. About 5,000,000 feet of lumber was destroyed.

The Canadian Pacific Railway Co. will apply to the Board of Railway Commissioners of Canada for authority to run a spur from their main line at St. Sauveur, Que., into the premises of the Frontenac Gas Co.

The city council, Sherbrooke, Que., have offered the Sherbrooke Power, Light & Heat Co. \$260,000 for their plant. In the event of refusing, work will be started on a new plant for the city at West Bury Basin.

The Maritime Boards of Trade are asking the Federal Government to take over all branch railways in the three provinces and add them to the government railway.

The Sackville Paper Box Co., Sackville, N.B., have been incorporated with a capital of \$20,000, to manufacture paper, paper boxes, bags, etc. The provisional directors include T. R. Anderson, W. B. Dixon and C. C. Avard, Sackville, N.B.

The Grand Bay lumber mill, St. John, N.B., was destroyed by fire September 23. Loss about \$15,000.

Application will be made at the next session of the legislature of New Brunswick, for the incorporation of the new Westmoreland Power Co. to build a street railway and works at Moncton, N.B.

The Bank of Montreal, Moncton, N.B., are calling for tenders for the construction of a branch there.

The premises of Perley's hotel and several outbuildings, Andover, N.B., were destroyed by fire, recently.

The congregation of St. Joseph's church Sydney, N.S., will erect a large edifice to replace the one recently destroyed by fire.

The Nova Scotia Steel & Coal Co., Sydney, N.S., purpose erecting a new sixty-ton steel furnace this fall, which will have twice the capacity of the four now in use.

The Bank of New Brunswick will open a branch in Halifax, N.S.

The Nova Scotia Telephone Co. are extending their line from Lakeville to Somerset by way of Grafton, N.S.

Two dredges are at work deepening the harbor, Lunenburg, N.S.

A Royal School of Military Engineering will be established at Halifax, N.S.

The streets of Amherst, N.S., will be further improved at a cost of about \$25,000.

The outbuildings of the prison at Halifax, N.S., were destroyed by fire recently.

The Nova Scotia Dental Association, Yarmouth, N.S., have passed a resolution to the effect that they will erect a dental college in Halifax, N.S., as soon as possible.

A branch of the Bank of Montreal will be opened at Charlottetown, P.E.I.

The Canadian Pacific Railway roundhouse at Napinka, Man., is being enlarged.

A site has been secured in Brandon, Man., and a new reformatory will be erected at a cost of about \$150,000.

The premises of the Waldorf Hotel, Winnipeg Beach, Man., were destroyed by fire September 25.

The Manitoba Iron Works of Winnipeg have installed a large amount of new machinery in their plant during the past year. With nearly 200 men on the pay roll they find their equipment inadequate to cope with a rapidly increasing business. Mr. T. R. Deacon, president of the company, who is chairman of the local branch of the Canadian Manufacturers Association, informed a representative of CANADIAN MANUFACTURER when in Winnipeg, lately, that the labor market in that city is much easier than it was three months ago, but that there is still a demand for good men in the iron working field. Prospects in the metal working line are good in the West with plenty of business in sight for some months to come.

The Ideal Fence Co., of Winnipeg, Man., are about to erect a fine brick office in connection with their factory.

The Czerwinski Box Co., of Winnipeg, Man., have just increased the manufacturing capacity of their plant by adding a battery of automatic nailers.

A large Wisconsin wagon company will erect a Canadian branch factory at Winnipeg, Man., to supply what has been their export trade in Western Canada for past three years.

Cleveland, Ohio, parties will commence to manufacture a full line of paint products at Winnipeg in 1908.

Winnipeg is the location selected by New York State leather glove & mitten manufacturers, a factory is to be started immediately, equipped with the latest labor saving machinery with a capacity of 100 dozen per day.

A St. Paul, Minn., agricultural implement firm, who have enjoyed a large export trade in Western Canada in past four years, will erect extensive factory buildings at Winnipeg, Man.

The plant at No. 5 well, Winnipeg, Man., was damaged by lightning to the extent of about \$5,000.

The Massey-Harris Co., Winnipeg, Man., purpose erecting a warehouse in that city at a cost of about \$21,000.

The capital of the Brandon Electric Light Co., Brandon, Man., has been increased to \$400,000.

The Minnedosa Power Co., Minnedosa, Man., have been formed and it is expected that the foundations for the dam will be completed this fall and the rest of the work finished in the early spring.

# Morris Machine Works

BALDWINVILLE, N. Y.

MANUFACTURERS OF

Centrifugal  
Pumping  
Machinery and  
Steam Engines

SPECIAL PUMPING  
OUTFITS TO SUIT  
SPECIAL  
REQUIREMENTS

Estimates Furnished  
upon Application

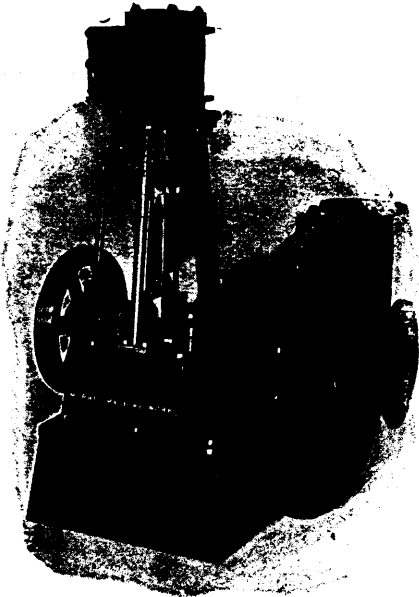

**H. W. PETRIE, Agent**  
Toronto, Canada

NEW YORK OFFICE: 39-41 CORTLANDT ST.  
HENION & HUBBELL, Agents, 61-69 North Jefferson St., CHICAGO, ILL.

# A Perfected Faultless Machine



The Ideal Concrete Block Machine has more than price to recommend it to the careful buyer. It is not only a practical and powerful machine producing the very highest grade of concrete blocks, but in speed, in quantity of output—in the profits earned at the end of every day—it absolutely excels. Moderate in cost, it enables the establishment of a profitable manufacturing industry with small capital. Equally suitable for the largest plant.

## IDEAL

(INTERCHANGEABLE)

Concrete Machines  
Various Sizes

The only concrete machine working on the Down-permitting practical use of rich facing material and coarser material for back of block.

There is no part of the "Ideal" machine that can ever break in use or need adjustment. So wonderfully simple a boy can operate it. Not a chain, spring or gear in its construction.

Beautiful catalogue, illustrating the entire line of Ideal Cement Machinery, sent free on application.

Ideal Concrete Machinery Co., Ltd.  
Dept. A I.  
LONDON, ONT.

Block, Brick and Sill Machinery, Mixers, Ornamental Moulds, Etc.  
MUSSEN'S Ltd., Sole Agents for Canada, Montreal, Quebec, Toronto, Winnipeg, Vancouver.

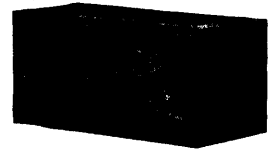

Ideal Block showing natural stone effect. Same machine makes countless different designs.

# WIRE GUARDS

—FOR—

FACTORY AND MILL WINDOWS  
SCHOOL AND CHURCH WINDOWS  
STORE AND BASEMENT WINDOWS  
AND FOR ALL PUBLIC BUILDINGS.

**THE B. GREENING WIRE CO., LIMITED**

HAMILTON, ONT.

MONTREAL, QUE.



## ACHESON-GRAPHITE—The Purest in the World

Manufactured in the Electric Furnace. Write us for full information regarding the use of this material in lubricating compounds, pipe joint compounds, as foundry facings, for electrotyping purposes, etc.

ACHESON-GRAPHITE ELECTRODES. Best for Furnace Work

Works at NIAGARA FALLS, ONT.

NIAGARA FALLS, N. Y.

INTERNATIONAL-ACHESON-GRAPHITE CO.,

Niagara Falls, N. Y., U. S. A.

James Thomson, Pres. and Man. Dir.    J. G. Allan, Vice-Pres.    James A. Thomson, Secretary.    Alex. L. Gartshore, Treasurer.

## The GARTSHORE-THOMSON PIPE & FOUNDRY CO.

LIMITED



**CAST IRON PIPE**

3 in. to 60 in. diameter.

For Water, Gas, Culverts and Sewers    Special Castings and all kinds of Flexible and Flange Pipe  
WATER WORKS SUPPLIES    HAMILTON, ONT.

## BANK OF HAMILTON

J. TURNBULL, General Manager

HEAD OFFICE, - HAMILTON, ONT.

Capital.	Reserve.	Total Assets.
\$2,500,000	\$2,500,000	\$32,000,000

96 Branches Throughout the Dominion of Canada.

Collections made in all parts of Canada on most favorable terms.

When writing to Advertisers kindly mention THE CANADIAN MANUFACTURER.

The premises of the Interwest Peat Fuel Co., Lac du Bonnet, Man., were destroyed by fire recently. Loss about \$40,000.

A gas plant is being installed in Waskada, Man.

The Board of Works, Brandon, Man., have decided not to commence work on the reinforced concrete bridge over the Assiniboine River until next spring.

The ratepayers of Souris, Man., voted favorably on a by-law to issue debentures to raise funds for the purchasing of Victoria Park.

The Manitoba Roman Stone Co., Winnipeg, Man., have been incorporated with a capital of \$100,000, to manufacture Roman stone, marble, granite, gravel, etc. The provisional directors include S. F. Peters, E. A. Duff and A. W. Morley, Winnipeg, Man.

The ratepayers of Melita, Man., have passed a by-law to spend \$5,000 in street improvements.

The Canadian Bag Co., Winnipeg, Man., will erect a warehouse at a cost of about \$10,000.

An English church will be erected at St. Charles, Man.

The ratepayers of Carberry, Man., voted favorably on two by-laws, one for \$8,000 to complete the fire system, the other for \$2,000 for the erection of a town hall.

A new stock exchange has been formed in Winnipeg, Man.

J. McDiarmid & Co., Winnipeg, Man., will commence at once the erection of the Union depot at Portage la Prairie, Man.

The Calgary Natural Gas Co., Calgary, Alta., who have been drilling for some time, discovered gas a few days ago shortly below 2,800 feet. It is the intention of the company to pump it into the city.

The new courthouse, which is being erected in Saskatoon, Sask., will be three stories high, 62x50 feet.

The Canadian Marble & Granite Co., Edmonton, Alta., commenced operations a few days ago.

Work will be commenced in the course of a week or two on the big 200,000 cubic yard fill at the western end of the Grand Trunk Pacific Clover Bar Bridge, Edmonton, Alta., for which the Canadian White Co., Montreal, have the contract.

The Canadian Northern Railway telegraph office at Moose, Sask., was destroyed by fire, recently.

The Ogilvie Milling Co. purpose establishing a branch of their business in Saskatoon, Sask.

C. S. Eaton, the western business manager of the International Lighting Co., of Cleveland, is in Edmonton, Alta., to complete the preliminary work, commencing with the installing of the plant for Edmonton and Strathcona. He will purchase a site for the gas works and let the contracts for the erection of the buildings. The buildings and plant of the gas company will cost \$100,000. The cost of installing mains will approach \$200,000, making a total expenditure of \$300,000. Over 30 miles of mains will be laid in the two cities.

The Canadian Bank of Commerce are erecting a new building at Kamsack, Sask., at a cost of about \$10,000.

The School Board, Weyburn, Sask., are taking steps to organize a High School.

The 760,000 bushel elevator being erected at Alameda, Sask., has been completed.

Messrs. Bergland & Playfair are erecting a new hotel at Windhorst, Sask.

The grading of the Canadian Northern Railway line is now completed as far as Kennedy, Sask., the new line running parallel with the Canadian Pacific Railway, at a distance of two miles north. It is expected that part of the line will be operated this fall.

Negotiations are under way to have the town of Kamsack, Sask., lighted by electricity.

A new school house will be erected at Kamsack, Sask., at a cost of about \$5,000.

A traffic railway bridge is to be built by the Government and the Canadian Northern Railway Co. at Prince Albert, Sask.

The abattoir being erected in Edmonton, Alta., by J. Y. Griffin & Co., will soon be completed.

The next session of the Legislature of Alberta will be held in a building which will be erected this fall in Edmonton. Plans have been prepared in the department of public works for a building, two storeys high, of brick with cement foundation and basement. The building will be located on Capital Hill, south of the present departmental offices now under construction.

The Canadian Northern Railway Co. are building a line from Vermilion to Calgary, Alta.

The new roundhouse of the Canadian Northern Railway at Saskatoon, Sask., is nearing completion.

Messrs. Wm. Harris & Son, Saskatoon, Sask., have purchased a site in Asquith, Sask., on which they will erect an implement warehouse.

The new office building of the Union Bank, Asquith, Sask., has been completed.

J. E. Doak, of Doaktown, N.B., will establish a factory at Saskatoon, Sask., for the manufacture of all kinds of house furnishings.

A. C. Flumerfelt and H. N. Galer have acquired a large area of coal deposits near Lethbridge, Alta. A large plant will be installed at once.

The city council, Moose Jaw, Sask., are considering a by-law to issue \$90,000 electric light extension debentures.

The Canadian Pacific Railway Co. have completed their branch to Lanigan, Sask. This line will be continued through to Saskatoon, and will be connected with Sheho and Regina, Sask.

An addition is being erected to the premises of the Canadian Bank of Commerce, Edmonton, Alta., at a cost of about \$8,000.

At a recent meeting of the Battleford Milling & Elevator Co., Battleford, Sask., the following directors were elected: H. G. Adams, president; W. R. Latimer, W. W. Livingstone, R. J. Coulter, D. T. Clink, and J. B. Macgregor, with F. G. Atkinson as secretary-treasurer.

The ratepayers of Olds, Alta., voted favorably on a by-law to raise \$12,000 for a fire protection service and public works.

The new building of the Dominion Bank, Strathcona, Alta., is almost completed.

The ratepayers of Estevan, Sask., will be asked to vote on a by-law to raise \$92,000 for waterworks purposes.

The Union Bank may erect a new building at Saskatoon, Sask.

The new city hall being erected at Rosethorn, Sask., will be ready for occupation by the end of November.

The large new mill of the Rosthern Flour Mills, Limited, Rosthern, Sask., is completed and machinery will be installed at once.

The Saskatchewan Telephone Co., Moose Jaw, Sask., have installed a telephone exchange in Rouleau, Sask.

Edmonton, Alta., are considering sending a commissioner through the United States and Canada canvassing for manufacturing firms. Woolens, tanneries, canned meats, factories for cotton goods and boot manufactures would include those canvassed.

J. C. Bonneau, Vancouver, B.C., has purchased the Strathcona hotel at Nelson, B.C., for the sum of \$50,000.

The steamer "North-west" was wrecked on the Skeena River, near Hazelton, B.C., recently. Loss about \$35,000.

The Dominion Copper Co., Boundary Falls, B.C., will enlarge their smelting plant.

The Tacoma Construction Co. are asking New Westminster, B.C., for a free site on Lytton Square, on which to erect a hotel and business block at a cost of about \$200,000.

The Porto Rico Co., Nelson, B.C., will erect a lumber mill with a daily capacity of 45,000 feet.

The ratepayers of Vancouver, B.C., voted favorably on a by-law appropriating \$300,000 for the improvement of the sewerage system, also \$100,000 for macadam roads.

A wireless telegraph station may be established at Port Essington, B.C., as a part of the Dominion Government wire system along the Skeena River.

James Milne, general superintendent of the British Columbia Electric Railway Co., Vancouver, B.C., states that the motive power to be used in the New Westminster-Chilliwack line, which will be entirely of new construction, will be electricity. It will be a standard-gage line, using 70 pound rails, approximately 60 miles long. Three surveys have been made, but the final route for two-thirds of the distance has not yet been selected. Work on 20 miles of line has already been commenced by company's forces, but it is probable that the company will let the balance of the work by contract.

The ratepayers of Vancouver, B.C., will be asked to vote on a by-law to raise \$1,000,000 for bridge building.

According to plans the Canadian Pacific Railway Co. intend spending \$1,500,000, on the development of six miles of coal lands at Fernie and Hosmer, B.C.

Work will soon be commenced on the new marine biological station at Departure Bay, near Nanaimo, B.C.

The Royal Bank of Canada have opened a branch at Kelowna, B.C.

The Board of Trade, Nelson, B.C., have passed a resolution endorsing the municipal ownership of telephones.

# HARBISON-WALKER REFRACTORIES CO.

PITTSBURGH, PA.

Makers  
Highest Grade  
Refractories  
Importers  
Chrome Ore  
Sole Agents  
Carl Spaeter Magnesite

Fire Clay, Silica,  
Magnesia, Chrome  
**BRICK**

Blast Furnace Linings, Stove Brick and Shapes, Open Hearth Furnace Refractories, Cupola Linings, Brick for Rolling Mill Furnaces, Brick for Copper, Nickel, Bräs and other Smelting Furnaces.

Rotary Cement Kiln Linings, Lime Kiln Brick, Beehive & by-product Coke Oven Brick, Locomotive Tile.

7,500 Regular Customers

Write for Booklet K

1,200,000 Daily Capacity

FRANCOIS HYDE & CO.,

Montreal Representatives



THE standard shapes and sizes of McCullough-Dalzell Crucibles will enable you to change readily from other makes. Our crucibles run three pounds of molten metal to the number. Write for prices.



McCULLOUGH-DALZELL CRUCIBLE COMPANY, PITTSBURGH, PA.

The Howe-Buller Co.  
CLEVELAND, O.

**FIRE BRICK**

SILICA FIRE CLAY  
ALUMNITE  
SILICA CEMENT

MAGNESITE BURNT MAGNESITE

Our factories are the most complete in the country. Located in Pennsylvania, Ohio, and Kentucky—and controlling the largest known bodies of Refractory materials for different work. Operated by experienced managers. We manufacture material for all heat work—second to none. Capacity over 200,000 Brick and Special Shapes per day. Write for catalogue.

If you want to sell to the manufacturers of Canada talk to them when they WANT to listen. They read this paper to hear what you have to tell them.

## Copper Clad Steel Wire

MONNOT PROCESS

A substitute for pure copper, combining great tensile strength with high elasticity.

**DUPLEX METALS COMPANY,**

Wm. C. Hawkins, General Agent,  
Myles' Building, Hamilton, Canada

**SADLER & HAWORTH**  
TANNERS & MANUFACTURERS OF  
**OAK LEATHER BELTING**  
AND LACE LEATHER  
**HYDRAULIC & MECHANICAL LEATHERS**  
DEALERS IN GENERAL MILL SUPPLIES

MONTREAL.  
Corner William & Seigneurs Sts.

TORONTO.  
9 Jordan St.

**THE IMPERIAL OIL COMPANY, Limited,**  
SARNIA, ONTARIO.

REFINERS AND MANUFACTURERS OF

**All Products of Petroleum**

Main Offices: Marketing Department, Montreal, Winnipeg, St. John, Halifax.

A

**WATER CURTAIN**

ON THE OUTSIDE OF  
YOUR BUILDING

Not only protects it from the  
**FIRE** in a neighboring building  
but **REDUCES YOUR**  
**INSURANCE** rate from  
**40% to 70%**

WRITE US TO-DAY FOR FULL PARTICULARS

**W. J. McGUIRE, Limited**  
TORONTO and MONTREAL

**ARTHUR P. TIPPET & CO.**

Montreal

**SULPHUR**

ROCK  
ROLL  
FLOWERS  
GROUND.

Any Quantities

From 15 Tons to 10,000



**SODA ASH**

LIGHT or HEAVY

THE MOST ECONOMICAL FORM OF SODA FOR MANUFACTURERS OF  
**GLASS, SOAP, PAPER, WOOD PULP**  
and **COLORS**, and for **PRINTERS**  
and **BLEACHERS**

**BLEACHING POWDER,**

HIGH STRENGTH, 35/37% IN  
HARDWOOD CASKS.

ALSO CAUSTIC SODA, SALSODA, CONCENTRATED SALSODA  
SALAMMONIAC, Etc.

**BRUNNER, MOND & CO., LIMITED, NORTHWICH, ENG.**

WINN & HOLLAND, Montreal, SOLE AGENTS FOR CANADA

When writing to Advertisers kindly mention THE CANADIAN MANUFACTURER.

**The Canada Chemical Manufacturing Company, Limited**  
 MANUFACTURERS OF

**COMMERCIAL  
 QUALITY**

**Acids and Chemicals**

**Chemically Pure  
 Quality**

**ACIDS:** Sulphuric, Muriatic, Nitric, Mixed, Acetic, Phosphoric, Hydrofluoric.

**CHEMICALS:** Salt Cake, Glauber's Salts, Soda Hypo, Silicate, Sulphide, Epsom Salts, Blue Vitrol, Alumina Sulphate, Lime Bisulphite, Nitrate of Iron, C.T.S. and Calcium Acid Phosphate.

Chemical Works and Head Office  
 LONDON.

Sales Office  
 TORONTO.

Warehouses  
 TORONTO and MONTREAL

**CASSELLA COLOR COMPANY**

(American Branch of Leopold Cassella & Co., G. m. b. H.)

ARTIFICIAL

**DYESTUFFS**

New York, 182-184 Front Street.

Boston, 68 Essex Street.

Philadelphia, 126-128 South Front St.

Providence, 64 Exchange Place.

Atlanta, 47 North Pryor Street.

Montreal, 88-88 Youville Square.

**W. T. Benson & Co.**

164 ST. JAMES ST., MONTREAL

**DOMESTIC WOOL**

Also direct importers of all kinds of Foreign Wools, Coconut, Palm and other Soap Oils.

AGENTS FOR  
 Wm. Blythe & Co., Church, England.

SOLE AGENTS:  
 British Dyewood & Chemical Co., Limited.

BRANCH  
 John W. Dawson & Co., and W. R. Scott & Co., Glasgow.

Manfr. Extract of Logwood, Fustic, Sumac, Quebracho  
 Extracts, Solid and Liquid.

Complete stocks of all above always on hand.

PRIZE MEDAL & HIGHEST AWARD PHILADELPHIA, 1876, FOR SUPERIORITY OF QUALITY, SKILFUL MANUFACTURE, SHARPNESS, DURABILITY, & UNIFORMITY OF GRAIN.

**GENUINE EMERY**

**Oakey's Flexible Twilled Emery Cloth.**

**Oakey's Flint Paper and Glass Paper.**

**Oakey's Emery Paper, Black Lead, etc.**

Manufacturers: **JOHN OAKEY & SONS, Limited,**  
 Wellington Mills, LONDON, ENGLAND.

*Enquiries should be addressed to—*

**JOHN FORMAN, 708, Craig Street, Montreal.**

**THE NICHOLS CHEMICAL COMPANY  
 OF CANADA, LIMITED**

Head Office—222 ST. JAMES ST., MONTREAL

Works—OAPELTON, P.Q.

MANUFACTURERS OF HIGHEST QUALITY CHEMICALS

**Sulphuric, Muriatic and Nitric Acids, Glauber's Salt, Salt Cake, Mixed Acid for  
 DYNAMITE MAKERS, Etc.**

AGENTS FOR STAR and TRIANGLE BRANDS  
**BLUE VITRIOL.**

PUREST AND STRONGEST  
**PAPER MAKERS' ALUM.**

Address all Correspondence to the Head Office, - MONTREAL.

When writing to Advertisers kindly mention THE CANADIAN MANUFACTURER.

# MACHINERY AND EQUIPMENT FOR SALE

## BUILDERS' SUPPLIES

OUR SPECIALTIES — LIME, CEMENT, sewer pipe, plaster Paris, fire brick and fire clay. ONTARIO LIME ASSOCIATION, 118 Epsalade Street East, Toronto.

## EDUCATIONAL

ELLIOTT BUSINESS COLLEGE, corner of Yonge and Alexander Streets, Toronto, ranks higher than the average college; students admitted at any time; advantages unsurpassed; graduates highly successful, catalogue free.

## PRINTING

THE COMMERCIAL PRESS, 47 Lombard Street, Toronto, make a specialty of commercial printing—Circulars, Letter-Heads, Statements, Etc. Good printing adds to the efficiency of any circular.

## INDUSTRIAL CENTRES

NIAGARA AND CATARACT POWER gives Welland cheapest electric lighting in Canada; manufacturers investigate our power, lake shipping and five railways. Write Board of Trade, Welland.

PORT DOVER, ONTARIO—In the natural gas belt; immense quantities of gas for manufacturing purposes at low rates. Has best sheltered harbor on north shore of Lake Erie, directly opposite Erie, Pa. South terminus of two branches of Grand Trunk; other railways building. Cheap coal and cheap electrical power. Good clay, sand, and limestone. Address W. K. Gordon, Secretary Board of Trade, Port Dover, Ont.

## COVERINGS AND INSULATION

MICA FIREPROOF COVERINGS.—Highest insulator of heat known. For boilers, flues, furnaces, steam and hot or cold water pipes, cold storage, sound insulation. Mica Boiler Covering Co., 86 to 92 Ann St., Montreal.

## BOILERS AND ENGINES

BOILERS.—For special quotations on boilers and sheet iron work, write Park Bros., Chatham, Ont.

## RUBBER STAMPS

B. CAIRNS, 77 QUEEN STREET EAST, Toronto—Rubber Stamps, Seals, Name Plates, Stenols.

## SCRAP METALS, PAPER, ETC.

E. PULLAN, TORONTO, positively the largest dealer in paper stock in the Dominion. Also buys rags, iron, metals, etc. Corner Adelaide and Maud. Phone Main 4633, Toronto.

## PLANS WANTED

CITY OF WOODSTOCK — PRELIMINARY competitive plans for a new City Hall for the City of Woodstock are invited. Cost of building, \$50,000. For all information apply to John Morrison, City Clerk, Woodstock, Ont.

## SALESMAN WANTED

WANTED—Aggressive salesmen calling on manufacturers in Maritime Provinces, to carry side line. Good commission. Address CANADIAN MANUFACTURER, McKinnon Bldg., Toronto.

## SPECIAL MACHINERY

GENERAL MACHINE WORK and repairing: special machinery. The Eccles & Rae Machine Co., machinists, 816 Bathurst Street, Toronto.

## PATENT RIGHTS FOR SALE.

LICENSES FOR SALE OR BRUSHES SUPPLIED under Canadian Patent No. 93,822, Sectional Hair Brush, the only hygienic hair brush known. Apply to Thomas S. Crane, 70 Nassau Street, New York, N. Y.

## FACTORY FOR SALE

NEW BRICK FACTORY, three floors, 48 by 98, two acres land, Cowansville, Que.; private siding C.P.R.; power, exempt from taxation, water free. Geo. J. Crombie, 74 St. Antoine St., Montreal.

## TYPEWRITER FOR SALE

REMINGTON—Second-hand, still in good condition. Just the machine for a firm not having a large correspondence. Will sell for \$20 f.o.b. at any station in Ontario. Address CANADIAN MANUFACTURER, Toronto.

## FOR SALE

FOR SALE—Automatic Stoker, with fan and engine complete, in good running order. Snap. Reason for selling, compelled to burn shavings. Apply A. J. H. Eckhardt, National Casket Co., 107 Niagara Street, Toronto.

WORK AND PRICES RIGHT  
**GALVANIZING**  
ONT. WIND ENGINE & PUMP CO.  
TORONTO, ONT.

## WM. BARBER & BROS.

Georgetown, Ont.

Manufacturers of . . .

## Book and Fine Papers

## I. C. FELL & CO.

STAMP MANUFACTURERS

DIE SINKERS

Write us.

ENGRAVERS

4 Adelaide West

TORONTO

THE.....

## Toronto Paper Manufacturing Co.,

Cornwall, Ont.

Manufacturers of Engine Sized Superfine Papers, White and Tinted Book Papers, Blue and Cream Laid and Wove Foolscaps, Account, Envelope and Lithographic Papers, etc.

CANADIAN OFFICE SCHOOL FURNITURE  
FINE BANK OFFICE, CHURCH & LODGE FURNITURE, COURT HOUSE & DRUG STORE FITTINGS. SEND FOR CATALOGUE

## R. SPENCE & CO.

HAMILTON, ONT.

FILE and RASP MANUFACTURERS

AND RE-OUTTERS.

A trial order solicited. Write for terms.

C. P. MOORE, PROPRIETOR.

## RAWHIDE GEARS

MANUFACTURED BY

THE HORSBURGH & SCOTT CO.

Cleveland, Ohio.

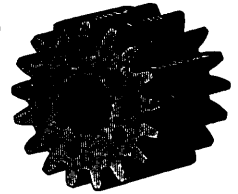

## FACTORY LOCATIONS.

The following Canadian municipalities are offering inducements to secure manufacturing establishments. Inquiries should be addressed to the Mayor, Town Clerk or Board of Trade of the respective cities

Barrie, Ont.

Hamilton, Ont.

Peterborough, Ont.

Regina, N.W.T.

Sherbrooke, Que.



## THE WELDING PROCESS FOR THE FOUNDRYMAN

Gives liquid steel at 5400° F. anywhere in half a minute.

Write for booklet.

Goldschmidt Thermo Co.  
334 St. James St., Montreal

## THE INJECTOR SAND BLAST APPARATUS

Patented in the DOMINION OF CANADA, May 9th, 1905, No. 93,054.

Manufactured and sold by

Canadian Sand Co., Limited.

MONTREAL, QUE. TORONTO, ONT. HALIFAX, N.S. KENORA, ONT. ROSSLAND, B.C. VANCOUVER, B.C.

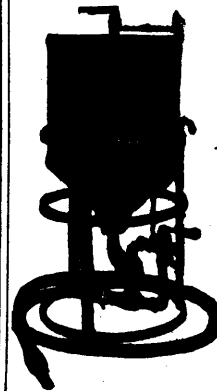

## Factory for Sale, Lease or Occupation

UNDER ADVANTAGEOUS CONDITIONS

Dimensions 100 by 50 ft.; five-story brick building resting on solid stone foundations, with Warehouses and WATER POWER. Apply to

LOUIS GOSSELIN, 112 ST. JAMES ST., MONTREAL

**FYFE'S STANDARD**  
**HAY, COAL AND WAGON SCALES**  
 Warranted Superior Quality.  
 498 St. Paul St., MONTREAL

**JOHN J. GARTSHORE**  
 88 Front St. W., Toronto.  
**Rails and SUPPLIES,**  
 New and Secondhand,  
 For RAILWAYS, TRAMWAYS, Etc.  
 Old material bought and sold.

**MACHINERY**  
 FOR  
 Wire Drawing.  
 Chain Making.  
 Core Machines for general foundry practice.  
 Vitrified Sewer Pipe.  
 Rubber Washing.  
 Reclaimed Rubber Water Separators.  
 Write us—  
**The TURNER, VAUGHN & TAYLOR CO.**  
 Cuyahoga Falls, O., U.S.A.

**VICES**  
 Bench Vises  
 Drill Vises  
 Miller Vises  
 Pattern Makers Vises  
 Get Our Prices.  
**The Stevens Mfg. Co., Limited**  
 GALT, ONT.

  
**ARMSTRONG'S RATCHET ATTACHMENT**  
 fits all GENUINE Armstrong Die Stocks. It is invaluable in corners, against walls and ceilings, or wherever the handles of a die stock cannot be turned.  
 It is a well-made tool and the cost is moderate.  
 Circulars and prices on application  
**THE ARMSTRONG MFG. CO.**  
 281 Knowlton St., BRIDGEPORT, CONN.  
 Chicago Office, 23 S. Canal St.

Established 1849.  
**BRADSTREET'S**  
 Capital and Surplus, \$1,500,000  
 Offices Throughout the Civilized World.  
**EXECUTIVE OFFICES,**  
 346 & 348 Broadway, New York City, U.S.A.  
 CORRESPONDENCE INVITED.  
**OFFICES IN CANADA:**  
 Halifax, N.S. Hamilton, Ont.  
 London, Ont. Montreal, Que.  
 Ottawa, Ont. Quebec, Que.  
 St. John, N.B. Toronto, Ont.  
 Vancouver, B.C. Winnipeg, Man.  
**THOMAS C. IRVING, Gen'l Manager Western Canada**  
 TORONTO.

**WOOD ENGRAVING**  
**PHOTO ENGRAVING**  
**HALFTONES**  
 OR ANY CLASS OF ENGRAVING  
 FOR ADVERTISING PURPOSES  
 CATALOGUES, MAGAZINES, &c  
**J.L. JONES ENG. CO.**  
 168 BAY ST - TORONTO

**The DOMINION OIL CLOTH CO.**  
 LIMITED  
 Manufacturers of...  
**LINOLEUMS**  
**FLOOR OIL CLOTHS**  
**TABLE OIL CLOTHS**  
 Also Carriage, Stair and Enamelled Oil Cloths, Decorative Burlaps.  
**Office and Works - MONTREAL**  
**F. W. HORE & SON, Limited,** HAMILTON, ONT.  
 Manufacturers of  
**CARRIAGE, WAGGON, AND SLEIGH WOOD WORK.**

  
**MAPLE LEAF**  
 STITCHED COTTON DUCK  
**BELTING**  
 DOMINION BELTING CO. LTD.  
 HAMILTON CANADA

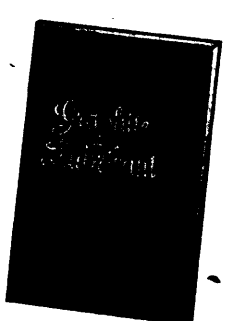
  
 Write for Free Copy  
**TENTH EDITION**  
 Dixon's latest book, "Graphite as a Lubricant," tenth edition, explains the modern practice of graphite lubrication and quotes experiments by scientific authorities and experiences of practical men.  
 GET FREE COPY, 25-C.  
**Joseph Dixon Crucible Co.**  
 JERSEY CITY, N.J., U.S.A.

**KEEPING DOWN COST**  
**THE WEBSTER FEED WATER HEATER**  
 IS THE GREAT SAVER OF STEAM AND FUEL  
 First—It uses only just enough of the exhaust to bring the feed-water to the highest point.  
 Second—It heats it by DIRECT CONTACT with the steam.  
 Third—It prevents waste from "back pressure" on the engine.  
 These and other points of advantage are to-day reducing the cost of production for hundreds of manufacturers so greatly as to make it very hard indeed for others with less efficient steam appliances to keep pace with them.  
 WRITE TO-DAY FOR CATALOGUE H.2.  
**DARLING BROTHERS LIMITED**  
 MONTREAL — TORONTO — WINNIPEG



## BALATA BELTING

Full Stock all Sizes

### GENUINE OAK LEATHER BELTING

ENGLISH CARD CLOTHING

All Sizes Sheets and Fillet

### D. K. McLAREN, Limited

Montreal, Toronto, Quebec, St. John, N.B.

Vancouver, B.C.



**NOTICE** The following are the Factory Inspectors for the Province of Ontario:

JAS. T. BURKE, Parliament Buildings, Toronto.  
 THOMAS KELTY, Parliament Buildings, Toronto.  
 ARTHUR W. HOLMES, Parliament Buildings, Toronto.  
 JOHN ARGUE, Parliament Buildings, Toronto.  
 MARGARET CARLYLE, Parliament Buildings, Toronto.  
 MRS. JAS. R. BROWN, Parliament Buildings, Toronto.

Persons having business with any of the Inspectors will find them at the above address. HON. NELSON MONTEITH, Minister of Agriculture,

B. & W. Patent  
Water - Tube

## BOILERS

Specially designed for the  
RAPID, ECONOMICAL AND SAFE

Generation of Steam up to the  
highest pressures.

Over 6,000,000 H.P. in use.

**BABCOCK & WILCOX,**  
LIMITED

HEAD OFFICE FOR CANADA:

New York Life Bldg., MONTREAL.

BRANCH—Traders Bank Bldg., TORONTO.

If We Asked \$10.00  
A Year Some People  
Would Gladly Pay It

The Globe Machine & Stamping Co. issue each month—a magazine of cleverness. Printer's Ink says, "It's the best ever" and everyone who reads it is fascinated by its originality. Not merely trade news—but choice stuff well served up.

A sample copy free if you write on your business letter-head. Address,

**THE GLOBE MACHINE &  
STAMPING CO.,** 977 Hamilton St.,  
Cleveland, Ohio.

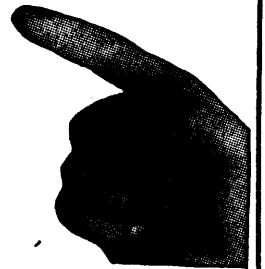

HYDRAULIC,  
KNUCKLE  
JOINT AND  
POWER SCREW

## PRESSES

The Canadian Boomer & Boschert Press Co., Ltd.

For Almost Every  
Purpose Requiring  
Pressure. Write us  
Your Requirements and  
Let us Quote You Prices

Send for Catalogue.

No. 1042 St. Catherine St. East, Montreal

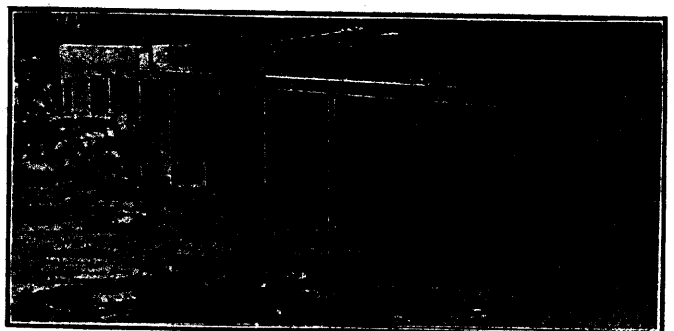
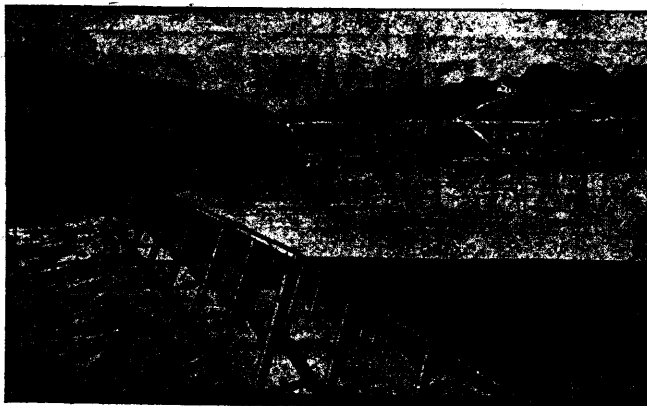

The Evolution of the Ambursen Dam from the Wooden Frame Dam. It is tight, indestructible, double the factor of safety of any Solid Dam and costs less to build.

AMBURSEN HYDRAULIC CONSTRUCTION CO. OF CANADA, LIMITED - 519 Coristine Building, Montreal

When writing to Advertisers kindly mention THE CANADIAN MANUFACTURER.

# INDEX TO ADVERTISEMENTS.

ifo ..... inside front cover.

ibo.....inside back cover

obo.....outside back cover.

A	PAGE		PAGE		PAGE
Abbott, Wm., Montreal.....	14	Canada Iron Furnace Co., Montreal.....	4	Electrical Inspection Bureau & Testing Laboratory, Montreal.....	12
Agriculture, Ontario Minister of, Toronto.....	56	Canadian Boomer & Boshert Press Co., Montreal.....	48	Elk Fire Brick Co., St. Mary's, Pa.....	15
Aitken, K. L., Toronto.....	14	Canadian Casualty & Boiler Insurance Co., Toronto.....	14	Elliott Business College, Toronto.....	46
Albert Mfg. Co., Hillsborough, N.B.....	8	Canadian Copper Co., New York, N.Y.....	11		
Algoma Steel Co., Sault Ste Marie, Ont.....	4	Canadian Fairbanks Co., Montreal.....	7	<b>F</b>	
Allis-Chalmers-Bullock, Limited, Montreal.....	ibo	Canadian Manufacturer Pub. Co., Toronto.....	14	Factory Inspectors, Ontario.....	48
Armbrusen Hydraulic Construction Co., Montreal.....	48	Canadian Office & School Furniture Co., Preston, Ont.....	46	Factory Locations.....	46
Armstrong Mfg. Co., Bridgeport, Conn.....	47	Canadian Rand Co., Sherbrooke, Que.....	ifo	Fell, I. C. & Co., Toronto.....	46
		Canadian Rand Co., (C. Druckleib, N.Y.).....	46	Fensom, C. J., Toronto.....	14
<b>B</b>		Cassella Color Co., New York and Montreal.....	45	Fetherstonhaugh & Co., Toronto.....	obo
Babcock & Wilcox, Limited, Montreal.....	48	Chapman Double Ball Bearing Co., Toronto.....		Forman, John, Montreal.....	12-45
Bank of Hamilton, Hamilton, Ont.....	41	Continental Iron Works, New York, N.Y.....	8	Fyfe Scale Co., Montreal.....	47
Baird, H. C., Son & Co., Parkhill, Ont.....	37	Crane, Thos. S., New York.....	46		
Barber, Wm. & Bro., Georgetown, Ont.....	46	Crocker-Wheeler Co., St. Catharines, Ont.....	13	<b>G</b>	
Barrett Mfg. Co.....	39			Gartshore, J. J., Toronto.....	47
Bechtels, Limited, Waterloo, Ont.....	37	<b>D</b>		Gartshore-Thomson Pipe & Foundry Co., Hamilton, Ont.....	41
Bell Telephone Co., Montreal.....	11	Darling Bros., Montreal.....	47	Globe Machine & Stamping Co., Cleveland, Ohio.....	48
Benson, W. T. & Co., Montreal.....	45	Dixon, Joseph, Crucible Co., Jersey City, N.J.....	47	Goldie & McCulloch Co., Galt, Ont.....	3
Berg, A. & Sons, Toronto.....	35	Dominion Belting Co., Hamilton, Ont.....	47	Goldschmidt Thermit Co., Montreal.....	46
Bertram, John & Sons Co., Dundas, Ont.....	obo	Dominion Heating & Ventilating Co., Hespeler, Ont.....	3	Gosselin, Louis, Montreal.....	46
Boiler Inspection and Insurance Co., Toronto.....	obo	Dominion Oil Cloth Co., Montreal.....	47	Greening, B., Wire Co., Hamilton, Ont.....	41
Bourne-Fuller Co., Cleveland, Ohio.....	4	Dominion Sewer Pipe Co., Swansea, Ont.....	10	Greey, Wm. & J. G., Toronto.....	16
Bradstreets, Toronto and New York.....	47	Dowie, Eben, Montreal.....	10	Gutta Percha & Rubber Mfg. Co., Toronto.....	
Brandeis, C., Montreal.....	14	Drummond, McCall & Co., Montreal.....	4		
Brantford Roofing Co., Brantford, Ont.....	8	Dun, R. G. & Co., Toronto.....	15	<b>H</b>	
Bristol Co., Waterbury, Conn.....	obo	Dunbar Fire Brick Co., Pittsburg, Pa.....	15	Hall, J. B. & Sons, Toronto.....	9
Brunner, Mond & Co., Northwich, England.....	44	Dynamic Machine Works, Limited, Montreal.....	9	Hamilton Facing Mills Co., Hamilton, Ont.....	obo
Budden, Hanbury A., Montreal.....	14			Hamilton Steel & Iron Co., Hamilton, Ont.....	5
Butterfield & Co., Rock Island, Que.....	6	<b>E</b>		Harbison-Walker Refractories Co., Pittsburg, Pa.....	43
		Eccles & Rae Machine Co., Toronto.....	46	Hay, Peter, Knife Co., Galt, Ont.....	10
<b>C</b>		Electrical Construction Co., London, Ont.....	13	Heys, Thomas & Son, Toronto.....	14
Cairns, Bernard, Toronto.....	46			Hore, F. W. & Son, Hamilton, Ont.....	47
Canada Chemical Mfg. Co., London, Ont.....	45			Horsburgh & Scott, Cleveland, Ohio.....	46
Canada Forge Co., Welland, Ont.....	5			Hunt, Robert W. & Co., Chicago, Ill.....	14
Canada Foundry Co., Toronto.....	12				

## Proper Heating Essential

Tensile strength, great durability and facility in welding depend on the treatment of the metal in the furnace.

Only experts handle the iron in the London Mills' Furnaces. This is the secret of the regularity of its good quality.

A trial order will make you a regular customer.

### London Rolling Mills London, Canada



Hydraulic Presses  
Power Screw Presses  
Filter Presses



**William K. Perrin  
Company, Limited  
TORONTO, CANADA.**

## INDEX TO ADVERTISEMENTS (Continued).

I	PAGE	R	PAGE
Ideal Concrete Machinery Co., South Bend, Ind.	41	Remington Typewriter Co., Toronto	7
Imperial Oil Co., Petrolia, Ont.	44	Robb Engineering Co., Amherst, N.S.	7
International-Acheson-Graphite Co., Niagara Falls, Ont.	41	<b>S</b>	
<b>J</b>			
Jeffrey Mfg. Co., Columbus, Ohio	6	Sadler & Haworth, Montreal	43
Jones & Moore Electric Co., Toronto	13	Senator Mill Mfg. Co., Galt, Ont.	14
Jones, J. L. Engraving Co., Toronto	47	Sheldons, Limited, Galt, Ont.	ife
<b>K</b>			
Kahn, Gustave, Toronto	14	Smart-Turner Machine Co., Hamilton, Ont.	obe
Kelly's Directories, Toronto and London Eng.	11	Smith's Falls Malleable Castings Co., Smith's Falls, Ont.	obe
Kerr Engine Co., Walkerville, Ont.	11	Spence, R. & Co., Hamilton, Ont.	46
<b>L</b>			
Laurie Engine & Machine Co., Montreal	ifo	Standard Bearings, Limited, Niagara Falls, Ont.	9
Legg Bros., Engraving Co., Toronto	ifo	Stevens Mfg. Co., Galt, Ont.	47
Lealie, A. C. & Co., Montreal	ifo	Storey, W. H., & Son, Acton, Ont.	14
London Rolling Mill Co., London, Ont.	49	Stowe-Fuller Co., Cleveland, Ohio	43
Lowell Crayon Co., Lowell, Mass.	14	Sunbeam Incandescent Lamp Co., Toronto	ifo
Lysaght, John, Limited, Bristol, Eng., and Montreal	obe	Syracuse Smelting Works, Montreal and New York	10
<b>M</b>			
Marion & Marion, Montreal	14	<b>T</b>	
Metallic Roofing Co., Toronto	ifo	Tippett, Arthur P., & Co., Montreal	44
Metal Shingle & Siding Co., Preston, Ont.	39	Toronto & Hamilton Electric Co., Hamilton, Ont.	12
Mica Boiler & Covering Co., Montreal	46	Toronto Paper Mfg. Co., Cornwall, Ont.	46
Mitchell, Charles H., C.E., Toronto	14	Toronto Pottery Co., Toronto	15
Monongahela River Consolidated Coal & Coke Co., Buffalo, N.Y.	15	Trussed Concrete Steel Co., Toronto	14
Morris Machine Works, Baldwinsville, N.Y.	41	Turner, Vaughn & Taylor Co., Cuyahoga Falls, Ohio	47
Morrison, James, Brass Mfg. Co., Toronto	11	<b>U</b>	
Morrow, John, Screw, Limited, Ingersoll, Ont.	11	Union Drawn Steel Co., Hamilton, Ont.	6
<b>Mc</b>			
McArthur, Cornelle & Co., Montreal	obe	<b>V</b>	
McCullough-Dalsell Crucible Co., Pittsburg, Pa.	43	Viau, Henri, Montreal	14
<b>N</b>			
Neff, A. C. & Co., Toronto	14	<b>W</b>	
Nichols Chemical Co., of Canada, Montreal	45	Weber Gas Engine Co., Kansas City, Mo.	ibe
Northern Aluminum Co., Shawinigan Falls, Que., and Pittsburg, Pa.	6	Williams, A. R. Machinery Co., Toronto	9
Northern Electric & Mfg. Co., Montreal	4	Winn & Holland, Montreal	44
Nova Scotia Steel & Coal Co., New Glasgow, N.S.	4	<b>Q</b>	
<b>O</b>			
Oakey, John & Sons, London, England	45	Queen City Oil Co., Toronto	obe
Ontario Lime Association, Toronto	46	<b>R</b>	
Ontario Wind Engine & Pump Co., Toronto	46	<b>S</b>	
Orford Copper Co., New York, N.Y.	11	<b>T</b>	
Otis-Fensom Elevator Co., Toronto	50	<b>U</b>	
<b>P</b>			
Packard Electric Co., St. Catharines, Ont.	13	<b>V</b>	
Park Bros., Chatham, Ont.	46	<b>W</b>	
Parke, Roderick J., Toronto	14	<b>Q</b>	
Pennsylvania Fire Brick Co., Beech Creek, Pa.	15	Queen City Oil Co., Toronto	obe
Perrin, William R., & Co., Toronto and Chicago, Ill.	49	<b>R</b>	
Phillips, Eugene F., Electrical Works, Montreal	13	<b>S</b>	
Producer Gas Co., Toronto	16	<b>T</b>	
Pullan, E., Toronto	46	<b>U</b>	
<b>Q</b>			
Queen City Oil Co., Toronto	obe	<b>V</b>	
<b>R</b>			
<b>S</b>			
<b>T</b>			
<b>U</b>			
<b>V</b>			
<b>W</b>			

# OTIS ELEVATORS

FOR ALL DUTIES

**Electric, Hydraulic, Belt, Steam  
and Hand Power**

MANUFACTURED BY

**OTIS-FENSOM ELEVATOR COMPANY, LIMITED**

Head Office, TORONTO, ONT.

Works, HAMILTON, ONT.

## The JOHN McDOUGALL CALEDONIAN IRON WORKS CO., Limited

MONTREAL, P.Q.



**Boilers:** Return Tubular, McDougall Water Tube, Etc.  
**Tanks:** Water Tanks, Penstocks, Filters.  
**Machinery:** Complete Power Plants designed and installed.

**Sole Manufacturers in Canada for Worthington Turbine Pumps and Doble Impulse Water Wheels.**

HEAD OFFICE AND WORKS: MONTREAL

DISTRICT OFFICES:

Montreal, 82 Sovereign Bank Bldg.      Vancouver, 416 Seymour Street  
Toronto, 810 Traders Bank Bldg.      Nelson, Josephine Street  
Winnipeg, 251 Notre Dame Ave.      New Glasgow, N.S., Telephone Bldg.

# WEBER PRODUCER GAS POWER PLANTS

SAVE 50 PER CENT. TO 75 PER CENT. OF YOUR FUEL COST!

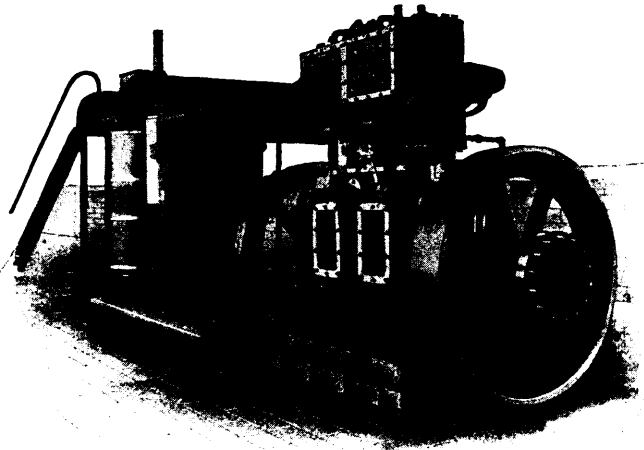

Complete Gas Engine and Producer Plant.  
Sizes to 1000 H. P.

**RESULTS**

FAIRVIEW, Okla.,  
Jan. 5, 1906.

Our 50 H.P. Weber Suction Gas Producer and Weber Gas Engine has proven to be all you claimed and has fully met your guarantee. We have run our Mill at a capacity of 80 bbls. per day, on a fuel consumption of 40 lbs. of semi-anthracite coal per hour. Our steam plant, which we discarded for the Gas Engine, was very expensive to operate. Our saving is far beyond our expectations; we keep accurate account of our power cost, both steam and gas, and our fuel cost is now reduced 75 per cent. Yours truly,  
FAIRVIEW MILLING CO.

**COUNT**

1 HORSE POWER  
1 HOUR  
1 POUND COAL

**WEBER GAS ENGINE CO.**  
BOX 411, KANSAS CITY, MO.

**FUELS:**  
ANTHRACITE COAL,  
COKE, CHARCOAL

# ALLIS - CHALMERS - BULLOCK LIMITED

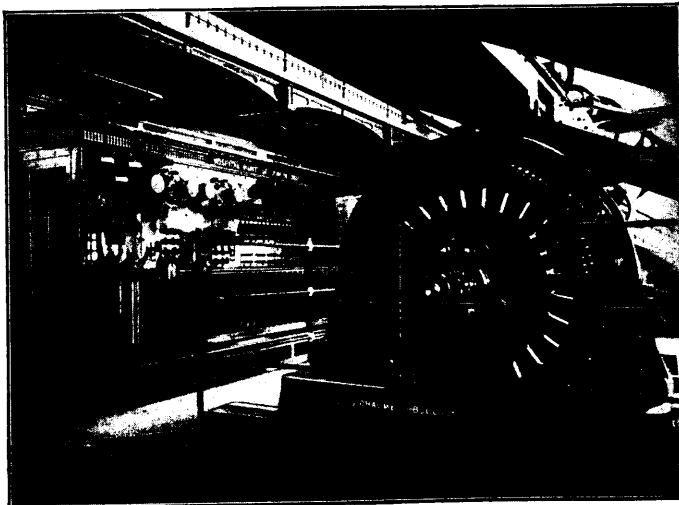

One of our 80 K. W. Belted Alternating Current Generators and Auxiliary Apparatus Forming the Lighting Plant of the Hospital Mont St. Jean de Dieu, Montreal.

“Allis-Chalmers” Mining, Saw Mill and Flour Mill Machinery, Engines, Pumps and Turbines.

“Bullock” Electric Apparatus.

“Ingersoll” Air Compressors, Rock Drills and Coal Cutters.

“Lidgerwood” Hoisting Engines.

Head Office and Works

**MONTREAL**

**District Offices** {

TORONTO - 810 TRADERS BANK BUILDING.  
WINNIPEG - 251 NOTRE DAME AVE.  
NELSON - JOSEPHINE ST.

MONTREAL - 82 SOVEREIGN BANK BUILDING.  
VANCOUVER - 416 SEYMOUR ST.  
NEW GLASGOW - N.S. TELEPHONE BUILDING.

**McARTHUR,  
CORNEILLE & CO.**

310 to 316 ST. PAUL ST.  
MONTREAL

**OILS, CHEMICALS, DYESTUFFS  
AND  
TANNING EXTRACTS**

*Waxes, Gums, Shellacs,  
Glues, Gelatines, Etc.*

CANADIAN AGENTS

FOR THE

BERLIN ANILINE CO.  
BRITISH ALIZARINE CO. and  
MILLER'S TANNING EXTRACT CO.

**THE BOILER INSPECTION  
and INSURANCE CO. of CANADA**

CANADA LIFE BUILDING  
TORONTO

Thirty Years' Experience as Consulting Engineers

Hull, Canada, 3rd November, 1905.

**THE BOILER INSPECTION & INSURANCE CO.  
OF CANADA., Toronto.**

Dear Sirs:—

We take pleasure in certifying that the engineering services rendered with the Policy of Boiler Insurance carried by your Company on about 30 boilers in the Eddy Company's plant is a paying investment, as the service given is of the highest order and results in great saving and a security against accident by explosion; in short, this service has given us the very best satisfaction.

Yours truly,

**THE E. B. EDDY CO., LIMITED**  
By GEO. H. MILLEN,  
Superintendent.

**Malleable  
Iron  
Castings**

**CAPACITY 4,000 TONS**

**McKinnon Dash &  
Metal Works Co.,  
LIMITED**

ST. CATHARINES, - ONT.

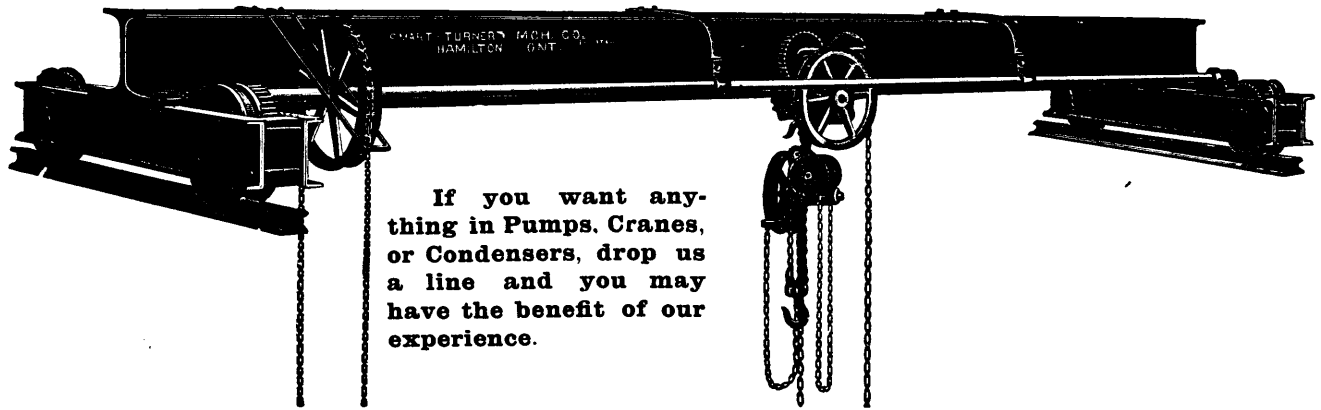

If you want anything in Pumps, Cranes, or Condensers, drop us a line and you may have the benefit of our experience.

**The SMART-TURNER MACHINE CO., Limited, - - HAMILTON, ONT.**

**"QUEEN'S HEAD"  
GALVANIZED IRON**

always used when  
quality counts

**JOHN LYSAGHT, LIMITED  
MAKERS**

**A. C. LESLIE & CO., Limited  
Canadian Manager**

**BRISTOL'S  
Recording Instruments**

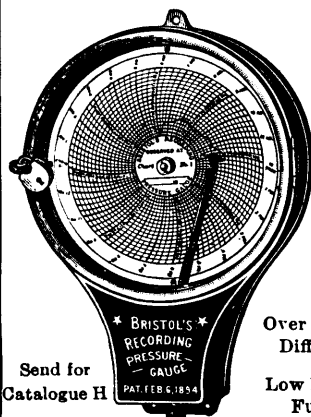

For.....  
**Pressure,  
Tempera-  
ture and  
Electricity.**

Over One Hundred  
Different Varieties.

Low Prices and  
Fully Guaranteed

Send for  
Catalogue H

Should be used by all Manufacturers.  
**THE BRISTOL CO.**

WATERBURY, CONN., U.S.A.  
NEW YORK—114 Liberty St.  
CHICAGO—753 Monadnock Bldg.  
LONDON—23 College Hill.

**Smith's Falls Malleable  
Castings Company, Limited**

**CAPACITY 4,000 TONS**

MANUFACTURERS

OF

**MALLEABLE  
IRON  
CASTINGS**

**Smith's Falls, Ont., Can.**

HAMILTON, ONT. Manufacturer of  
 Ceylon Plumbago Supplies  
 FOUNDRY  
 SHIP'S  
 also Extra Fine Quality  
 MOLDING SAND  
 from the finest Brass  
 sand to the coarsest  
 Pipe and Core Sand.  
 WRITE FOR PRICES.