

Technical and Bibliographic Notes / Notes techniques et bibliographiques

The Institute has attempted to obtain the best original copy available for filming. Features of this copy which may be bibliographically unique, which may alter any of the images in the reproduction, or which may significantly change the usual method of filming, are checked below.

L'Institut a microfilmé le meilleur exemplaire qu'il lui a été possible de se procurer. Les détails de cet exemplaire qui sont peut-être uniques du point de vue bibliographique, qui peuvent modifier une image reproduite, ou qui peuvent exiger une modification dans la méthode normale de filmage sont indiqués ci-dessous.

- Coloured covers/
Couverture de couleur
- Covers damaged/
Couverture endommagée
- Covers restored and/or laminated/
Couverture restaurée et/ou pelliculée
- Cover title missing/
Le titre de couverture manque
- Coloured maps/
Cartes géographiques en couleur
- Coloured ink (i.e. other than blue or black)/
Encre de couleur (i.e. autre que bleue ou noire)
- Coloured plates and/or illustrations/
Planches et/ou illustrations en couleur
- Bound with other material/
Relié avec d'autres documents
- Tight binding may cause shadows or distortion along interior margin/
La reliure serrée peut causer de l'ombre ou de la distorsion le long de la marge intérieure
- Blank leaves added during restoration may appear within the text. Whenever possible, these have been omitted from filming/
Il se peut que certaines pages blanches ajoutées lors d'une restauration apparaissent dans le texte, mais, lorsque cela était possible, ces pages n'ont pas été filmées.
- Additional comments:/
Commentaires supplémentaires:

- Coloured pages/
Pages de couleur
 - Pages damaged/
Pages endommagées
 - Pages restored and/or laminated/
Pages restaurées et/ou pelliculées
 - Pages discoloured, stained or foxed/
Pages décolorées, tachetées ou piquées
 - Pages detached/
Pages détachées
 - Showthrough/
Transparence
 - Quality of print varies/
Qualité inégale de l'impression
 - Continuous pagination/
Pagination continue
 - Includes index(es)/
Comprend un (des) index
- Title on header taken from:/
Le titre de l'en-tête provient:
- Title page of issue/
Page de titre de la livraison
 - Caption of issue/
Titre de départ de la livraison
 - Masthead/
Générique (périodiques) de la livraison

This item is filmed at the reduction ratio checked below/
Ce document est filmé au taux de réduction indiqué ci-dessous.

10X	14X	18X	22X	26X	30X
<input type="checkbox"/>	<input type="checkbox"/>	<input type="checkbox"/>	<input type="checkbox"/>	<input checked="" type="checkbox"/>	<input type="checkbox"/>
12X	16X	20X	24X	28X	32X

THE CANADIAN MANUFACTURER

DEVOTED TO *
 THE MANUFACTURING & MINING INDUSTRIES, OF THE DOMINION. *
 OF THE INDUSTRIAL WORLD.

Vol. 14.

TORONTO, JANUARY 20, 1888.

No. 2.

Established 1856.

The J. C. McLAREN BELTING CO. Successors to the Late J. C. McLAREN.

CARD CLOTHING

Set in Leather, Cotton, Natural Rubber, Backing in Iron, and Patent Tempered Steel Wire.

SOLE AGENTS FOR THE DOMINION,

SYKES' PATENT NEEDLE POINTED CARDS.

292 & 294 ST. JAMES STREET, MONTREAL.

Now is the time to place orders for early spring delivery.

"Old Dyewood Warehouse"

Established 1838.

Theo. H. Eaton & Son,

Windsor, Ont. : Detroit, Mich.

IMPORTERS OF

ANILINE COLORS,
 DYE WOODS.

DYEING DRUGS, CHEMICALS, Etc.

MANUFACTURERS OF

GLAUBER SALTS AND EXTRACT INDIGO.

SOLE AGENTS IN THE UNITED STATES AND CANADA FOR THE "CROWN ANILINE DYES."

THE

Gutta Percha & Rubber

MANUFACTURING COMPANY,
 OF TORONTO.

WAREHOUSE

YONGE STREET, TORONTO.

The largest manufacturers in the world of Vulcanized India Rubber Goods for mechanical purposes.

Rubber Belting from 1 to 72 inches wide.

Hose, for conducting, suction and steam.

Packing, Cloth Insertion and pure.

Tubing, of all kinds.

Rubber, Linen, and Cotton Fire Hose.

Maltese Cross Carbolized Fire Hose.

A full Stock always on hand.

Write for Price Lists and Discounts.

W. R. BROCK & CO.

IMPORTERS OF

General Dry Goods

TORONTO.

We are prepared to pay "SPOT CASH" for clearing lines of Canadian Manufactures.

These lines we offer to our customers at a small advance.

We make a specialty in the following :

Canadian Tweeds, Blankets, Flannels,
 Yarns and Knitted Goods.

CANADIAN COTTONS.

W. R. BROCK & CO.

PATENTS

PROCURED in Canada, the United States and all foreign countries, Caveats, Trade-Marks, Copyrights, Assignments, and all Documents relating to Patents, prepared on the shortest notice. All information pertaining to Patents cheerfully given on application. ENGINEERS, Patent Attorneys, and Experts in all Patent Cases.

RONALD C. RIDOUT & CO.

ESTABLISHED 1857
 22 KING ST. EAST
 TORONTO

Imperial Bank of Canada.

Head Office - Toronto.

H. S. HOWLAND, President, | T. R. MERRITT, Vice-President.
 D. R. WILKIE, Cashier.

Capital Paid-up - \$1,500,000
 Rest - \$850,000

Purchases Municipal Debentures.
 Issues Drafts on its Branches and Agencies in the North-West.
 Transfers Moneys by Telegram to Winnipeg and Brandon.

Agents in London,

LLOYD, BARNETT & BOSANQUET'S BANK (Limited).

62 LOMBARD STREET,

with whom moneys for transmission from Great Britain to Ontario and the North-West may be deposited.

A general Banking Business transacted.

John Bertram & Sons,

CANADA TOOL WORKS!

Dundas, Ont.

SEE ADVERTISEMENT, PAGE 64.

J. C. DIXON & BROS.

WORSTED SPINNERS,
 DUNDAS, Ont.

MANUFACTURERS OF

FINGERING, KNITTING,

and all descriptions of

WORSTED YARNS.

The Canadian Bank of Commerce.

HEAD OFFICE, - - - TORONTO.

Paid up Capital, - - - - - \$8,000,000.
Reserve, - - - - - 500,000.

DIRECTORS.

HENRY W. DARLING, Esq., *President.*
GEORGE A. COX, Esq., *Vice-President.*
Jas. Crathern, Esq., W. R. Hamilton, Esq.,
Wm. Gooderham, Esq., John I. Davidson, Esq.,
Matthew Leggat, Esq., George Taylor, Esq.,
Hon. Wm. McMaster, Hon. S. C. Wood.
B. E. WALKER, GENERAL MANAGER.
J. H. PLUMMER, ASST. GEN. MANAGER.
WILLIAM GRAY, INSPECTOR.

New York—J. H. Goadby & Alex. Laird, Agents.
BRANCHES.

Ayr,	uelph,	St. Catharines,
Barrie,	Hamilton,	Sarnia,
Belleville,	Jarvis,	Seaford,
Berlin,	London,	Simcoe,
Blenheim,	Montreal,	Stratford,
Brantford,	Norwich,	Strathroy,
Chatham,	Orangeville,	Thorold,
Collingwood,	Ottawa,	Toronto,
Dundas,	Parkhill,	Walkerton,
Dunnville,	Paris,	Windsor,
Galt,	Peterboro,	Woodstock,
Goderich,		

Commercial credits issued for use in Europe, the East and West Indies, China, Japan and South America.

Sterling and American Exchange bought and sold. Collections made on the most favorable terms. Interest allowed on deposits.

BANKERS.

New York—The American Exchange National Bank.
Chicago—American Exchange National Bank.
London, England—The Bank of Scotland.

**M^CARTHUR,
CORNEILLE & CO.**

(Successors to JOHN McARTHUR & SON)

310 to 316 St. Paul Street,
and
147 to 151 Commissioners Street,
MONTREAL,

offer at closest prices

PURE OLIVE OIL.
WINTER-PRESSED LARD OIL,
EXTRA FINE SPINDLE OIL,
and a full assortment of other
LUBRICATING OILS.

Also

**CHEMICALS,
DYESTUFFS,
DYEWOODS,
EXTRACTS,**

&c. &c. &c.

Are Sole Agents in Canada for
SOCIETE ANONYME

DES

**MATIERES COLORANTES ET
PRODUITS CHIMIQUES,
DE ST. DENIS,**

Successors to

**A. POIRRIER AND G. D'ALSACE,
PARIS,**

Manufacturers of

**ANILINE DYES,
ARCHIL
CUDBEAR,
&c. &c. &c.**

Prize Medal, London Universal Exhibition,
1862.

Gold Medal, Paris Universal Exhibition,
1867.

Grand Diploma of Honor, Vienna Universal
Exhibition, 1873.

Medal and Diploma, with Highest Com-
mendations, Philadelphia Centennial Ex-
hibition, 1876.

Maintain large stock, replete with all the new and improved colors. Will be pleased to furnish quotations with samples and directions for use.

D. MORRICE, SONS & CO.
Manufacturers' Agents,
MONTREAL & TORONTO.
HOCHELAGA COTTONS.
Brown Cottons and Sheatings, Bleached Sheatings, Canton Flannels, Yarns, Bags, Ducks, etc.
ST. CROIX COTTON MILL.
Ticking, Denims, Apron Checks, Fine Fancy Checks, Gingham, Wide Sheatings, Fine Brown Cottons, etc.
ST. ANNE SPINNING CO. (Hochelaga.)
Heavy Brown Cottons and Sheatings.
Tweeds, Knitted Goods, Flannels, Shawls, Woolen Yarns, Blankets, etc.
The Wholesale Trade only Supplied.

**New York Dyewood, Extract
and Chemical Co.**
MANUFACTURE HIGH GRADE
**CURED CHIP LOGWOOD
FOR WOOL DYEING.**
OFFICE:
55 BEEKMAN ST., N.Y.
WORKS, BROOKLYN.

**MIDDLETON & MEREDITH,
MONTREAL.**
CHEMICALS AND DYE STUFFS,
Sal Soda, Soda Ash, Bleaching Powder,
Caustic Soda, Bi-Carb. Soda, Chlorate,
of Potash, etc., etc.
Extracts Indigo, Sumac, Fustic, etc.,
Gambier, Cutch, Sumac, etc., Acids,
ANILINE DYES,
Brooke, Simpson & Spiller's. Full Assortment on hand.
PHOSPHOR BRONZE, SILICATE CLOTH.

PILLOW, HERSEY & CO.,
Manufacturers of every description of
Cut Nails, Tacks, Brads, Railway and
Pressed Spikes, Horse Shoes, Carriage, Tire
and other Belts, Coach Screws, Hot Pressed
and Forged Nuts, Felloe Plates, Lining and
Saddle Nails, Tufting Buttons, &c., &c.
The Hardware Trade, Shoe and Leather
Finding Dealers, and Boot and Shoe Man-
ufacturers, will find the Largest and Best
Assortment and Greatest Variety of above
Goods always in stock, and can rely on orders
being rapidly executed, our facilities for
doing so being unequalled.
OFFICE, 91 St. Peter St. Montreal.

**DOMINION
Card Clothing Works,
York St., Dundas.**
**W. R. GRAY & SONS,
PROPRIETORS,**
MANUFACTURE EVERY DESCRIPTION OF
**Card Clothing and
Woolen Mill Supplies.**

**Largest Manufacturers of STEEL
and BRASS STAMPS in Canada.**

**PRITCHARD
& ANDREWS
OTTAWA, ONTARIO.**

**Rubber Stamps,
Stencils, Seals, &c.
SEND FOR PRICES.**

**DOMINION
DYEWOOD & CHEMICAL CO.**

SOLE MANUFACTURERS OF

The Celebrated Yorkshire Scouring and
Fulling Soaps,
Neutral Cotton Seed Oil Soaps,
Pure Lard Oils specially adapted for the
Woollen Trade.

IMPORTERS OF

Indigo, Cochineal, Cudbear,
Indigo Ext., Cutch, Archil,
Madder, Dyewoods,
Dyewood Extracts and all Dyeing Drugs,
ANILINE DYES, ALL COLORS.

SPECIALTIES ARE

Imperial Blue, Fast Seal Brown,
Fast Acid Brown, Brilliant Scarlets,
Azo. Green, Fast Cardinals
Fast Acid Garnet.

Office: 77 FRONT ST. E. **TORONTO.** Works: Don Station.

THE J. A. CONVERSE
MANUFACTURING CO'Y

A. W. MORRIS & BRO., Proprietors,
MONTREAL.

Manilla, Sisal.	Red Cap	Jute and Cotton	Calcined and Land
Russian and	Brand	Bags,	Plaster,
Jute Cordage.	Manilla	Hessians	Portland
Red Cords,	Binder	Hop	Cement,
Lathies, Etc.	Twine is always	Sacking.	Cod Oil
	uniform.	Etc., Etc.	all Brands.

AHEAD	OF ALL COMPETITORS IN CORDAGE!
	OF ALL COMPETITORS IN BINDER TWINE
	OF ALL COMPETITORS IN PLASTER!

And we open our NEW BAG WORKS early in 1888 with strong expectations of being
AHEAD OF ALL COMPETITORS IN BAGS.

This Space for Sale.

Authorized Capital and other Assets over
\$5,000,000.

MANUFACTURERS' LIFE INSURANCE COMPANY

— AND —
Manufacturers' Accident Insurance Company

ISSUE ALL KINDS OF LIFE AND ACCIDENT POLICIES
 AT THE LOWEST POSSIBLE RATES.

Special advantages are given Manufacturers' to indemnify themselves against the

"Workmen's Compensation for Injuries Act."

SIR JOHN A. MACDONALD, P.C., G.C.B. - - PRESIDENT.

SIR ALEX. CAMPBELL, K.C.M.G. }
 GEORGE GOODERHAM, Esq. } - - VICE-PRESIDENTS.
 WILLIAM BELL, Esq. }

J. B. CARLISLE,
Managing Director.

**38 KING STREET EAST,
 TORONTO, ONT.**

This Space for Sale.

The Canadian Manufacturer.

Published on the first and third Friday of each month, by the
CANADIAN MANUFACTURER PUBLISHING Co., (Limited).

6 WELLINGTON STREET WEST, TORONTO.

ANNUAL SUBSCRIPTION, in Advance \$2.00

ADVERTISING RATES SENT ON APPLICATION.

FREDERIC NICHOLLS, *Editor.*

J. J. CASSIDEY, *Managing Editor.*

ED. D. McCORMICK, *Secretary.*

This Journal has won for itself an acknowledged position amongst Trade Journals and is recognized as the representative industrial paper of Canada. All the various industries of the country are represented in its columns, and it has been for years the fearless and consistent advocate of those reforms which were indispensable to the success of the Manufacturers. It now reaches nearly every mill and factory in the Dominion, and its influence is constantly increasing.

As a medium for advertisements of machinery, steam appliances, mill and factory supplies, etc., it is unequalled, and our rates will be furnished on application.

Communications from Manufacturers, Exporters, and others, are respectfully invited.

Any association of manufacturers who may desire to hold meetings for organization or other purposes, are invited to avail themselves of the meeting room adjoining the office of the CANADIAN MANUFACTURER.

MR. FREDERIC NICHOLLS is Secretary of
The Canadian Manufacturers' Association,
The Woolen Manufacturers' Association, and
The Tanners' Association.

His Office is at the Publication Office of
THE CANADIAN MANUFACTURER,
6 Wellington Street West, Toronto.

THE TALL CHIMNEYS.

GRIT newspapers and anti-Canadian statesmen take great pleasure in calling attention to any misfortune that may befall any manufacturing industry in this country, when such occurs, and attribute the fact to the failure generally of the National Policy to maintain such establishments. Bad management will wreck a factory as surely as it will a bank or any other institution, and when isolated cases of such failures occur, they may properly be attributed to bad management, but not to the policy that is fast making Canada a great self-sustaining manufacturing nation.

What has occurred in one place may, under similar circumstances, again occur in another place. England, impelled by an ambition to become the mistress of the mercantile world as she had already become of the political world through the prowess of her arms and the valor of her sons, by means of a more stringent protective policy than has ever prevailed in any other country, fostered and encouraged her manufacturing enterprises until they were in a position to control the markets of the world. It is true that when this coveted position had been attained that policy was modified, and the products of the world granted general free admission to her ports, but this was in the interests of her manufacturers, and after the tall chimneys of her factories had become the most prominent feature of the landscape of the whole country.

But England has a rival approaching with giant strides which is fast becoming formidable in many branches of indus-

try in which it was fondly believed no rivalry could ever exist. But a few years ago—in 1865—the United States adopted a high tariff policy, the chief object of which was to raise revenues with which to liquidate and pay off the enormous debt incurred in suppressing the great rebellion. At that time the iron industries of that country were weak and inconsequential, and there were no steel plants at all; and in 1867, when the manufacture of steel rails was begun there, under a protection of \$27 a ton, and when the entire output of steel rails was only 2,550 tons, similar rails commanded \$130 a ton in gold in England. To-day the United States stands first in the magnitude of its production of steel. In 1886 Great Britain produced 2,364,670 gross tons of steel, and the United States produced 2,562,502 tons. That is to say, the United States in that year surpassed England in steel production by nearly 200,000 gross tons; and in that year the giant strides of the American Republic placed that nation not only abreast with, but actually in advance of Great Britain as a producer of steel.

As we have said, the production of steel rails in the United States in 1867 amounted to only 2,550 tons, but in 1877 it was 432,169 tons, in 1886 it reached 1,768,922 tons; while in 1887, according to Mr. Swank, of the American Iron and Steel Association, the production was 2,295,594 net tons, more than a half million tons greater than in 1886. And the improvement in the quality of the article has kept pace with the wonderful increase of production, while the cheapening of the cost has been equally remarkable; for the current price of steel rails in the United States at this time is only \$33 per ton. The protective tariff alone built up the steel industry in the United States, and freed that country from dependence on Great Britain for that article. The tariff which established this industry, created active competition at home, and competition improved the quality and reduced the price.

That the existence of the United States tariff does not prevent foreign trade in steel is shown in the fact that the Italian Government are making arrangements to have the steel armor plates for some of the war ships now being built in Italy manufactured in American steel works. Italy is an ambitious country, and is anxious to have her navy second to none that floats; and even now some of the Italian war ships are claimed by experts to be more powerful and effective than any in either the British or French navy. Certainly the armament of some of these ships is heavier and more formidable than any possessed by any other power. Heretofore all the armor plates for the Italian navy and nearly all the heavy guns have been made in England, and only the greater excellence of the steel made in American plants could induce the alert and skilful experts to change their orders from British to American manufacturers. And not only as regards armor plates is the fact most remarkable, but heavy steel guns also; for, but a few days ago, the largest, longest and heaviest solid steel cannon that was ever made was successfully cast in a Pennsylvania steel works.

Without the encouragement of Protection is it possible that the United States could ever have achieved the distinctions which we have here alluded to, and have wrested such valuable laurels from Great Britain? Certainly not. And if the United States, under Protection, can achieve so much through the tall chimneys of their manufactories, why may not Canada do as much for herself under our National Policy? There is no reason why we should not, and we will.

CATSPAWS.

THE strike now in progress among the coal miners and employees on the coal roads in Pennsylvania is doing great injury to the whole country with the exception of the mine operators and the ring in which they are the central figures. The price of coal is going up steadily, and great suffering is existing in consequence in all the large cities, many industrial establishments having already shut down and thousands of workmen thrown out of employment for the lack of fuel. The strikers show no signs of backing down, and the Reading Railway Company and the mine operators are said to be boasting that they have millions of dollars which they are ready and willing to spend, if necessary, to carry their point. The case is clearly one of locked horns as between the mine operators and the coal-carrying railroads, and organized labor, the trouble having had its origin in the discharge of a few men, and which could and should have been avoided.

It is evident that the object the operators and railroads had in view in maneuvering to bring about this strike was to enhance the price of coal; and that they have made catspaws of the labor organizations to rake these chestnuts out of the fire. But with the exception of manufacturers who have to shut down their works for lack of fuel, the laboring classes generally are the only ones who are suffering for fuel, and out of whose pockets the advanced prices are wrung. Those who are able to do so—the better situated classes of the community—usually during the summer lay in their winter's supply of coal, and this at the low prices that always prevail during the summer and fall months; or at any rate they arrange with dealers for such supplies, the dealers regulating their stocks of coal accordingly, and so, whether the price of coal goes up or not during the winter, these consumers are not taxed with the difference. The poorer classes—those who cannot make such favorable arrangements, but must of necessity buy their fuel in small quantities and as occasion requires—are the ones who have to pay the advanced prices growing out of the labor troubles, and among these sufferers are the strikers themselves, and their families.

It is a noticeable fact that these strikes never occur except when the coal companies have large quantities of coal on hand at the breakers and elsewhere, and after their friends have their yards and depots well filled up, and when they are perfectly willing to cease mining for a few weeks. To continue mining under such circumstances—when the markets are well supplied, and plenty of coal in sight—would reduce prices and profits; and to prevent such a situation—to reduce supplies and to send up prices—a well-worked strike is the most available tool to be used.

Of course an outcry of public indignation would be raised if the work of mining was voluntarily abandoned, even for a short time. The labor element would denounce the suspension, and say that their bread was being withheld from them; and the public would join in the denunciation. Such a step would not indicate wisdom, and the method to obtain the desired suspension is clearly by inducing a strike. It counts for much in favor of a party to a difficulty if it can be shown that the other party is in the wrong, or apparently so, and it is surprising what a little thing will induce a strike; and although the leaders of organized labor flatter themselves that they

know all about it—when, where and how to strike—they have more than their match in the coal and railroad men, who are adepts at the business. The arbitrary discharge of a single workman, made at the desired moment, will throw the labor unions into terrible commotion, and the refusal to reinstate him will almost always be sufficient cause in their judgment to make an exhibition of their manliness and independence by ordering the strike. By this or similar simple and easy process a thousand or ten thousand men may be induced to throw down their tools and quit work, to the great delight of those who are to be benefitted thereby; and by and by, when nothing further is to be gained by keeping the men out on strike, a conference is called, the discharged man fully reinstated, and the strikers resume work. The strike is a benefit to the ring, for it accomplishes all that was desired, and the ring can well afford to pacify the strikers by finally acceding to their demands when they had been served so faithfully and at no cost.

Do we ever read of these big strikes occurring in the summer, when the weather is warm and pleasant? Not much. If the workmen have any demands to make they are complied with, and the work of mining and transporting coal, and piling it up in distributing depots, goes merrily on; the operations being conducted with a view to having all the coal wanted taken out and distributed by the time hard winter weather prevails, and the occasion is a suitable one to squeeze an extra dollar or two a ton out of poor consumers.

THE FARMERS' CASE.

CANADIAN farmers are told by the Commercial Union organs that they are "suffering from a reign of combines in sugar, cotton, binding twine, etc., and from the imposition of high duties on iron and other necessaries and conveniences of their calling." They are also told that "a comparison of Canadian manufacturers' prices of a dozen years ago with Canadian manufacturers' prices of to-day has really no bearing on the case, the true method being to compare our manufacturers' prices with the manufacturers' prices current in England or the United States." The *Mail* says that if this be done it will be found that "the high tariff and the combines together are extorting from the Canadian farmer an enormous tribute"; and that if this proposition be denied "the restrictionists must explain the meaning of the Canadian manufacturers' outcry against Commercial Union, and their protests against Free Trade with England." The "restrictionists" alluded to are those Canadians who do not desire either Commercial Union with the United States or Free Trade with England.

It is a common habit with some debaters to set up men of straw as targets against which to hurl their arguments and then proceed to demolish them with a grand flourish of trumpets, calling attention to their valiancy with which the feat is accomplished. We presume that human nature all over the world is subject to similar impulses, for if it is true that there are "combines" in Canada, the system of combinations is an importation from free trade England, where it luxuriates, probably the worse displays of it to-day being seen in the United States. A sugar combination now exists in the United States into which every refining concern has been drawn, and which

controls the entire trade in that necessary article. No more objectionable and oppressive "combines" could possibly exist than those known as the Standard Oil Company and the American Cotton Oil Trust; and other combinations there include all the manufacturers of salt; the manufacture of steel rails, miners of anthracite coal, and even labor. As regards the manufacture of binding twine, the manufacturers there, through their combination, extort even higher prices from American farmers than what Canadian farmers have to pay, while, at the same time, they get rid of their surplus stock by forcing, or trying to force it, upon the Canadian market at less than actual cost. They have two objects in view in doing this—one to keep their own factories in operation, making the American consumers pay the loss on their foreign sales; the other to break down the manufacture of the article in Canada, and to destroy the competition they meet here from Canadian manufacturers. With Canadian binding twine factories wiped out of existence, Canadian farmers would soon have to pay even higher prices for their twine than American farmers are forced to pay by the American binding twine combination.

It is exceedingly nonsensical for the *Mail* to tell Canadian farmers that they are "suffering from the imposition of high duties on iron" and suggesting Commercial Union with the United States as the panacea therefor, when the American tariff on all forms of iron is higher than ours. Commercial Union would result in Canada having to adopt the higher American tariff. It is not a fact that prices for the "necessaries and conveniences" of Canadian farmers demanded by Canadian manufacturers are extortionate, or even higher than the prices of similar articles made in the United States; or that they pay an "enormous tribute" for home made goods. It is an established fact that agricultural implements, which are most essential "necessaries and conveniences" to farmers, are even cheaper in Canada than in the United States, and this without reference to the tariff question; and the contention that the cost of such articles to Canadian farmers would be lessened by Commercial Union is clearly a case of setting up an antagonist of straw merely for the purpose of confusing the issue. As in many other lines of manufacture, the American manufacturers of agricultural implements have formed a combination by which they extort from American farmers even a much higher price for their goods than what Canadian farmers have to pay for similar goods; and Canadian farmers may felicitate themselves that the existing condition of things prevents their being brought under and controlled by the influences that handicap their Yankee competitors.

It is demanded that "an explanation be given of the Canadian manufacturers' outcry against Commercial Union, and their protests against Free Trade with England." In view of what is above written this "demand" is the merest bosh. The idea sought to be impressed upon the minds of Canadian farmers is that the great and unbearable evils under which they are now struggling arise from combinations of Canadian manufacturers of certain lines of goods, such as sugar, cotton, binding twine, etc., and the imposition of duties on iron and other necessaries and conveniences, such as agricultural implements, etc.; and the remedy and cure suggested for these evils is Commercial Union with the United States. But we have shown that these ills are imaginary, as to many of the particu-

lars, and that as to the others they exist to a greater and more alarming extent in the United States than they do in Canada, and that neither commercial nor political union with that country would improve the situation. If the objection to the position taken by Canadian manufacturers who desire neither Commercial Union nor Free Trade consists only in the particulars here advanced against them, those objections having been successfully set aside, it does not lie with their opponents and detractors to further question their motives or reasons.

BOOMERANGS AND TWO-EDGED SWORDS.

THE historian should now be accumulating data which will enable him to write in the not distant future a history of "strikes" and "trusts" as they now prevail and affect social and political life in the American Republic. And in so writing he will necessarily show that strikes, and its equally objectionable corollary the boycott, were the direct cause of those other objectionable things—trusts and combines. He will show that the growth of them was of a fungus and pernicious character; that they sprung up and polluted the moral atmosphere for a while, all honorable men holding their noses while they passed by; and that like other stinks they gradually subsided—plowed under by public sentiment, the same as the farmer plows under the noxious weeds that show themselves in his fields.

The historian will show that organized labor was the aggressor, and that it first brought the influence of the strike to bear in enforcing its demands; that it soon called the boycott into existence as its auxiliary; and that these weapons proved to be of such terrible and potential character as to cause it to forget that while it was well to possess the strength of a giant, it was cowardly to use that strength indiscriminately. He will remark that heroic remedies may possibly answer good purpose in some desperate cases, and that severing Gordian knots may be an easy solution of difficult problems; but he will also remind his readers, on the authority of Holy Writ, that he who taketh the sword is liable to perish by the keen thrusts of that warlike weapon. He will also suggest that strikes and boycotts are a species of boomerang that inevitably return to smite and injure those who hurl them; and that while these boomerangs go out in the form of strikes and boycotts, they return bearing marked resemblance to trusts and combinations.

It may appear to organized labor that the boomerangs it hurls are the best weapons they can use in defense of its "rights" and in the enforcement of the "justice" it may think is being withheld; and that it is fully justified in their use; but it will be told that the community at large differs from it, and abhors such methods of warfare. Neither do the public feel any leniency towards the trust and the combine for they, too, are organized not in the interest of the public, but for revenge and punishment as against offenders, and for greed and gain as against the whole world. If the trust and combine hurt and injure labor, labor should not complain if it is wounded by the boomerang which itself had hurled. Discovering that it possessed the strength of a giant, and had used that strength injudiciously and extravagantly, it should not feel surprised that those against whom that strength was used should develop

similar strength, and ingeniously cross with it swords equally formidable as its own.

But there should be no warfare, no fighting, no strike between those who should be good friends. No single person or class of persons is benefitted by strife, and all are injured by warfare, by strikes and boycotts, and by trusts and combines. A strike to be effective must be made to include every one who might possibly be affected by it in the remotest degree, which is practically impossible; and a boycott requires that the list of boycotters be equally exhaustive and far-reaching, which is also impossible. So, too, with the trust, which is a modern invention which has sprung into being since the advent of the strike and the boycott. Its aim is to embrace and control the whole productive capacity of some particular line of business, by doing which it is enabled to supply all current demands for the products of that business, although the strike may be enforced in some of the workshops, factories or sources of production embraced within the trust. "Divide and conquer" is a military maxim that finds forcible application here, for though a strike may be in progress in some places, it is not apt to be general; and if certain makers of goods are under the ban of the boycott, similar goods, produced within the trust, supply the market, the profits upon which are divided with the boycotted concern. A forcible illustration of the working of the trust as against the strike and boycott was shown in the action of the Stove Founders' Defence Association in the United States last year. The moulders in a St. Louis stove foundry struck, and the works were shut down. No work could be done in that foundry, but according to the agreement of the trust, or association, the patterns were sent to another foundry to be put in the sand, whereupon the Stove Moulder's Union ordered these patterns to be boycotted, and then the merry war began. These patterns were sent to all the stove foundries in St. Louis, and being boycotted, the moulders refused to touch them; and so foundry after foundry was closed, and the lock-out and strike went arm in arm. If the trouble had remained stationary in St. Louis the stove moulders throughout the balance of the country would have assessed themselves for the benefit of the strikers, and the foundrymen would have been forced to the wall. This had been done before, but the manufacturers had learned wisdom from experience; and the boycotted patterns were sent successively to Chicago, Detroit, Pittsburgh, Cleveland, Louisville, Cincinnati and other prominent stove manufacturing centres, and soon nearly every stove foundry embraced within the trust was shut down and the whole fraternity of stove moulders idle. About this time the moulders began to think that probably they had been somewhat hasty in hurling their strike and boycott boomerang, and concluded that as it usually takes more than one to make a bargain, it would be well to consult the manufacturers. This they did, and soon all the foundries were reopened and the men busily at work again.

Such instances are of constant occurrence, and almost always with similar result. But still such combinations are undesirable, and should not be resorted to only as a last expedient. No one censures the Stove Defence Association for combining for protection against the strike and boycott, for without such action the entire trade would have become demoralized and great losses would have followed. They acted purely in self-

defence, and they proved that in union there is strength. The natural tendency of such combinations, however, is to turn this defensive weapon into one of aggression, and to use it, not to resist but to perpetrate wrong, for their pecuniary benefit; and these very systems of trusts and combines have taken such fast hold upon the very vitals of trade and commerce in the United States as to alarm the people and create a clamorous demand for Congressional interference. That organized labor is alarmed by the boomerang and two-edged sword of the strike and boycott is shown by the resolution passed by the recent Peoria, Ill., Convention of Federated Trades, which emphatically declared against these dangerous weapons.

EDITORIAL NOTES.

A BILL has been introduced into the United States Congress to create a navigable canal between Lake Erie and Lake Ontario, through the State of New York.

MR. JAMES H. BARTLETT, M. E., Montreal, who is accepted as reliable authority on the subject, is writing a series of articles on "The Canadian Iron Trade," which are being published in the *Canadian Mining Review* of Ottawa.

No fewer than thirty-one different railroads in the United States, nearly one-third of which are in New York and Pennsylvania, aggregating 5,478 miles long, and representing an apparent capital investment of \$328,000,000, were sold in bankruptcy during 1887.

AN Order-in-Council directs that veneers of wood, shaved or cut with a knife, direct from the log, not planed or otherwise smoothed or manufactured in any way, shall be classed and rated for duty, and duty shall be levied and collected at the rate of ten per cent. *ad valorem*.

THE British farmer, in addition to land rent, has to pay heavy local taxation for poor rates and so forth.—*Toronto Mail*. Will the *Mail* explain with some minuteness of detail what "heavy local taxation" is embraced in the phrase "and so forth"? The explanation would be exceedingly interesting to Canadian farmers.

A PETITION has been sent from Kingston, Ont., to the Minister of Finance asking that work may be begun on the proposed Government dry dock at that place, the necessary surveys for which have already been made. The impression prevails in some quarters that the dock will be built by convict labor, but we hope this will not be done. It would be a great mistake to employ convicts in the construction of this or any other Government work.

Toronto is a great city. It contains the *Empire*—aye, even the *Globe* and the *World*. A *Sentinel* is posted at its gates, and a *Guardian* protects its people, while a *Churchman* looks after its spiritual welfare, and a *Review* is held once a week. No wonder there is *News* to send in *Telegrams* and some left to go by *Mail* as late as *Saturday Night*. One thing it lacks—a better *Grip on Truth*.—*Ingersoll Chronicle*.

DON'T forget the CANADIAN MANUFACTURER, without which Toronto's greatness could not have been builded.

A COMPANY has been formed in Chicago for the manufacture of paving blocks, street rails, etc., from paper pulp, which may consist largely of straw and similar cheap material. The pulp is compressed into shape by means of hydraulic machinery, and the possibilities of the business are practically unlimited. A great advantage claimed in the use of paving blocks made of paper pulp over those of granite is, that they are noiseless. They are also impervious to moisture; cannot be affected by the weather, and are practically indestructible.

ACCORDING to the returns of the British Board of Trade, during 1887 the exports from Great Britain to Canada increased £51,439, or one per cent. over 1886, while the imports from Canada increased £340,329, or 4.47 per cent. The Free Trade advocates tell us that unless we buy freely, *i.e.*, remove our duty upon imports, we cannot possibly sell freely, *i.e.*, of our natural products. But the above figures show that Great Britain wanted and took from us nearly \$350 worth of our products more last year than was taken the year before for every \$100 worth of goods that we took from there.

LORD SALISBURY, the British premier, in a speech made in Liverpool last week, referring to the movement in that country in favor of Fair Trade, said that experience had shown that the Free Trade theory had been carried too far, or misapplied, in consequence of which some reaction was probable. The sugar bounties question, he said, was an instance of the hurtfulness of indiscriminate Free Trade. Agriculture was a more difficult question, but it must be admitted that the interests of the producer and the consumer in the productions of the English soil were bound by a common interest, and must stand or fall together.

A CASE illustrating the depression in the wool trade in the United States caused by the proposition of President Cleveland to remove the duty on wool, was tried in a St. Louis court a few days ago. In October last a dealer in the city sold 10,000 pounds of unwashed wool for future delivery, at 21 cents per pound. In the meantime Mr. Cleveland's message was promulgated, and the price of wool fell to 14 cents. The buyer declined to receive the wool, and suit was sought to enforce the contract. The President's message was brought to be introduced in evidence, to show the cause of the great depreciation, but it was not done.

A PROJECT is now on foot in the United States to form a mica pool, to control the entire production of mica in that country. Prices of mica have been unusually low for some months past. The strike of the stove moulders during 1887 limited the demand for mica; and now, with the prospect of great activity among the stove manufacturers, the demand is likely to increase. The number of mines in the country from which good, clear mica of the best sizes can be obtained is small. They are situated chiefly in North Carolina and New Hampshire. Most excellent mica, suitable for manufacturers' use, is found in considerable quantities in the Ottawa district, and the mica mining industry in Canada will be likely to receive quite a boom if the proposed combination in the United States is perfected.

THE Singer Sewing Machine Company, who have an extensive factory at Elizabeth, N. J., and another at Glasgow, Scotland, pay out \$35,000 a week in wages to their hands working in their Elizabeth factory, and \$18,000 to those in their Glasgow factory. The average earnings of these hands per week in the Elizabeth factory is \$13 and in the Glasgow factory, \$5. Of course, if Mr. Cleveland's Free Trade ideas should be formulated into law, the Elizabeth factory, where the hands earn \$13 per week, would be closed, and the Glasgow factory, where the hands earn but \$5 per week, would be correspondingly enlarged. But how would the workmen in the American factory like it?

A BILL introduced into the United States Congress imposes a license tax of \$1,000 per annum upon manufacturers of adulterated lard, \$500 upon wholesale dealers in the same, and \$50 upon retail dealers. Adulterated lard, it provides, shall be sold in packages branded and labeled so that all purchasers may know what they are buying. A tax of one cent per pound is levied upon all domestic adulterated lard, and a duty of two cents per pound on imported adulterated lard. Penalties are provided for violations of the provisions of the bill. Another bill calls for the repeal of the tax upon oleomargarine, substituting a general enactment that all adulterations and imitations must be sold under labels truthfully stating their ingredients, and that any evasion of this law shall be cause for seizure and criminal prosecution.

THE physical condition of Michigan is very similar to that of Ontario, and the "hopeless and helpless" farmers of Ontario are told by the Commercial Unionist and Annexationist that Commercial Union with, or Annexation to the United States would make them more prosperous and happy than they now are. But would they? The recent report of the Michigan Commissioners of Labor certifies that 43,079 of the 90,803 farms in that State are oppressed by mortgages to the amount of from 55 to 60 per cent. of their assessed valuation, and that the annual interest thus required to be met is more than twice as much as all the taxes paid upon the property. Michigan stands tenth in the list of States as to value of agricultural products, but it is only a question of time how long her farmers can bear up under the terrible load that now oppresses them.

CANADA does not place any duty upon school-teachers coming into the country, and, therefore, according to the arguments of the Free Traders, being open to the markets of the world, and particularly those of Great Britain and the United States, we should be enjoying a plethora of A No. 1 school teachers. But we don't have them, and those that we do have are probably the poorest paid set of bread-winners in the Dominion. The average hostler or servant girl employed in cities obtain, many of them, twice as much as the average school-teacher in the rural districts. One hundred and fifty dollars a year is the usual inducement offered in many districts, and if the rising generation are not as well educated as they should be, it is to be attributed to the reluctance of the taxpayers to pay decent salaries.

ABOUT twenty of the threshing-machines manufacturers of Ohio, Michigan, Wisconsin and Indiana have decided to form

an organization for mutual protection and harmony of interests, to be known as the American Threshing-Machine Manufacturers' Association. There are about forty manufacturers in the United States, and it is expected that within a short time all will become members. Already agricultural implements are much higher in price in the United States than in Canada, and this combination is intended to give the screws another turn. Do Canadian farmers wish they had Commercial Union? Not much. If they had, the American Threshing-Machine Manufacturers' Association would, with their immense aggregation of capital, squeeze the very existence out of Canadian manufacturers, and when they were good and dead Canadian farmers would dance merrily to the music.

In our "Manufacturing" department will be found a brief account of the works and business of the organ and piano manufacturing firm of Messrs. Wm. Bell & Co., of Guelph, Ont. They have several tall chimneys to their works, the existence of which is due entirely to the National Policy that makes manufacturing in Canada possible and profitable. Of course, strict integrity and correct business principles are requisites, and these exist to an eminent degree in this concern. It is not an "infant industry," for they have outgrown their adolescence, and their business extends not only throughout the Dominion, in North America, but into all the great geographical divisions of the globe—Europe, Asia, Africa and Oceanica. This is but one of the many industries now existing in Canada that have achieved similar prominence, thanks to Canadian enterprise and energy and our Canadian National Policy of protection.

In the United States Court at Dubuque, Iowa, recently, in a trial in which the Washburn & Moen Manufacturing Company, of Worcester, Massachusetts, had sued a barb wire manufacturing company for infringement of what is known as the Glidden patents for the manufacture of barb wire, owned by them, it was decided that these patents were invalid, because the same or a similar device was in use as early as 1859, while the Glidden patents were not issued until several years later. This is the third unfavorable decision which has been rendered against the Washburn & Moen Company within the last two years, each of which they have appealed to the Supreme Court of the United States, at Washington. This Washburn & Moen monopoly has borne heavily upon manufacturers, dealers and users alike, not only in the United States, but in Canada also, and if it is finally decided that the Glidden patents are worthless, barb wire factories would probably become quite numerous in Canada, and the price of the article greatly reduced.

An Ottawa correspondent of the London *World* cabled the following a few days ago:—

"Sir John Macdonald, the Canadian Premier, says that the Canadian Parliament will reject the project of a Commercial Union with the United States soon after its next meeting by over 200 votes. He adds "I think a Commercial Union would be disastrous at present to what we call our National Policy. Our quasi-protective system has only existed since 1879, and of course the protection offered to certain manufactures did not create them at once. They are growing steadily, but still no great capital has been invested or generated, and

they would be at once swamped by the wealth and long-trained skill of Americans. We are in a state of gristle yet, and the Americans understand that so well that they would make any great sacrifice for a market at first, simply to kill off ultimately all our manufactures. The time will come when we can meet them on even terms. But that is not the case now. Very few could fight the Americans, in fact only a very small minority."

CARDINAL TASCHEREAU, of Quebec, has caused a letter to be read in the churches in that city condemning the Knights of Labor. He thinks he sees a resemblance between them and Free Masons, in that both bodies observe their peculiar rituals, and also secrecy, and therefore he brings both under his ban. His Eminence can never be either a Knight of Labor, or a Free Mason, and in denouncing these bodies he speaks of that of which he knows absolutely nothing. Time may have been when ecclesiastical thunder might have frightened weak souls, but not this time. The Knights of Labor, however, in common with the whole community of the city and province of Quebec, are interested in having all the secular real and personal property owned and controlled by Cardinal Taschereau and his church assessed and pay taxes the same as other similar property. Our ears are open to hear the Cardinal advocate equal justice for all in this direction. Will he speak? Why should his property be exempt from taxation, and the property of Knights of Labor and others be taxed.

WE are informed that a few days ago a representative of a prominent jewelry manufacturing house of Toronto was traveling on the Grand Trunk railroad, west, and the baggage-man, in taking the passenger's trunk from the baggage car, placed it on the platform in such a manner that when the train started the trunk was thrown under the wheels and destroyed. The railway company repudiate any liability in the matter, shielding themselves behind the contract printed on the back of the commercial traveler's ticket. This is a very important matter to all such travelers and their employers, for by the gross carelessness of a servant of the railroad company, the owners of the destroyed property are subjected to considerable loss, against which, according to the declaration of the company, there is no redress. We think an action at law for damages would lie, despite the so-called "contract" printed on the back of the ticket, for the company and their servants are bound at all times to take good care of property entrusted to them. They probably rely on the disinclination of the owner of the property to go to law to recover its value.

SOME eight years ago a large part of the nickle used in the United States was the product of the nickel mines near Phoenixville, Pa., a portion of it being prepared for the mints for the manufacture of subsidiary coin. The manufacturer could make this nickel for \$3 a pound, and the duty at that time was \$2 a pound. German nickel was worth only \$2 a pound, and the ruling market price of the article was \$4 a pound. About that time nickel was placed upon the free list, and the price was immediately reduced to \$2, whereupon the works here alluded were closed and the hands thrown out of employment. When the production of nickel was abandoned, for the cause here stated, the price of imported nickle went up to \$4 a pound, where it was under the tariff, and where it has been

ever since, except when about five years ago the production of the article was again attempted, when the importers again depressed the price and again forced the stoppage of the industry. The general result is that consumers pay now just the same price for free nickel that they had to pay for protected nickel, and there is no nickel manufactory in the country.

A poor woman named Mrs. Farr, who resides on Robert Street, fell Thursday afternoon on John Street, near Cannon, and broke her arm. It appears that her husband, who is an old man and a bricklayer, was debarred when work was plentiful because he was not a union man, and Mrs. Farr has been the mainstay of support to the family through scrubbing and washing. Now, however, she will be laid up for some time, and the family are in distress. The case is a sad one.—*Hamilton Spectator*.

"DEBARRED work when work was plentiful because he was not a union man." Was there ever a sadder commentary upon the tyranny of trades unionism? A poor old man prevented from earning an humble though scanty living when work was to be had, because he was not a member of an honorable (?) labor organization, and his poor old wife compelled to be "the mainstay of support to the family through scrubbing and washing." And now the rigors of winter are upon them; old Mr. Farr, the bricklayer, can get no work, and old Mrs. Farr cannot scrub and wash any more through having unfortunately broken her arm. The cowardly action of the late city council of Hamilton permitted the brave, (?) honorable (?) and generous (?) bulldozers of the labor organizations there to keep this poor bricklayer, Farr, from working when work was to be done, because he did not belong to their order, and now the poor old man and his crippled wife may die like dogs for all the bulldozers care. What a pity these heartless wretches are not arrayed in striped clothes and doing the State some service in the Kingston penitentiary.

A CORRESPONDENT, whose communication appears elsewhere, does not agree with what we said in a previous issue of this journal regarding the employment of convict labor in competition with free labor. He says that at the annual approach of winter there are hosts of tramps and vagabonds who scour the country and commit depredations for the sole purpose of securing comfortable quarters and good food without exertion, until spring time comes, when they are again turned loose to wander about the country to the terror of the female habitants of the farms. Our correspondent thinks he has discovered a solution of the convict labor question when he suggests that the offending tramps and vagabonds be set to work improving country roads, breaking stones, gravelling, digging ditches, etc., to which there can be no earthly objection. But there is a legal and moral discrimination between the offense of being a tramp and a vagabond, which may be punished in the way suggested by our correspondent, and the more serious crimes committed by murderers, burglars, thieves and such, who are not incarcerated only during the winter months and turned out when the flowers bloom in the spring, but for long years. It is lamentable that men should commit heinous crimes, but the welfare of the community demands that criminals be restrained of their liberty, and thus to restrain them costs money which the community must be taxed to raise. Such taxation is a bur-

den which must be borne, even as the taxation to build and maintain country roads and other necessary institutions must be borne. It may be all right and proper to compel tramps and vagabonds to work on the highways, but it is not right to employ convict labor in competition with free labor in skilled mechanical industries.

THE Brantford *Telegram* tells of a recent meeting of moneyed men in that city to discuss the forming of a joint-stock company to make shoes. A Mr. Kelly, inventor and patentee of a seamless shoe on which he receives a royalty in Canada and the United States, was present, and made sundry representations as to the advantages of his shoe and of the profits of the business. He suggested that with \$20,000 capital a hundred hands could be employed, who would turn out 500 or 600 pairs per day and make from 75 cents to \$2.50 wages per day. Regarding this the *Monetary Times* says that if Mr. Kelly can do this he is a treasure, and those Brantford capitalists had better secure him at once. In addition to being an inventor and patentee of an "economic" shoe, he must be the inventor of a new and economic way of doing business, if he can turn out 175,000 pairs of boots and shoes in a year on a capital of \$20,000 and make money. Our contemporary doesn't seem to catch on to the prevailing scheme when large bonuses are required to boom the boomers bonusing business. Brantford, however, where the thing has been run into the ground, don't feel as much interest in such things now as formerly, although the *Courier* of that town says that the people there seem prepared to vote money for any and every enterprise, no matter how uncertain the guarantee or dim the project. That paper, speaking of the passage of the \$50,000 railway by-law bonus at the election held on January 2, says:—"Not only has the municipality assumed a burden of \$4,000 yearly extra taxation at a time when local undertakings of vital importance and immediate necessity stare the city in the face, but in addition all this has been accomplished at the expense of jeopardizing the best paying industrial establishment in the city, while the people do not even yet know the details of the proposed enterprise in which they have invested their money."

THE *Mail*, in elaborately describing the condition of the farmers throughout the world, and telling them how miserable they are, alluding to the British farmer says that in addition to the rent of the land which he has to pay, "he has to pay heavy local taxation for poor rates and so forth." It will be borne in mind that the *Mail* desires to have Canada abandon its National Policy of Protection, and take up the Free Trade policy that obtains in Great Britain. The burden of its argument to the farmers is, that by doing so they would be able to buy all the necessaries and comforts of life much cheaper than they do now, the difference corresponding to the amount of "protection" afforded by the tariff to Canadian manufacturers. It will also be borne in mind that there are few or no direct taxes now imposed upon Canadian farmers, the revenues of the Government, which are applied to the maintenance of the Government, being raised chiefly by duties imposed upon imports of merchandise. It costs a great deal of money to support the British Government, but the revenues raised for that purpose are not realized from duties levied upon imports, but

To Mill-Owners, Manufacturers, and all who use Leather Belting.

IF YOU WANT BELTING

Which will Run Straight on the Pulleys;

Which is thoroughly well Stretched;

Which will Not Tear at the Lace Holes;

Which will give Complete Satisfaction;

- SEND TO -

F. E. DIXON & CO.

MANUFACTURERS OF

Patent Lap-Joint, Star Rivet

Leather Belting

70 KING STREET EAST, TORONTO.

Special Belts for Electric Light Machinery;

Belting made from the very Best Canadian Leather;

Belting made from American "Genuine Oak Tanned Leather";

Rubber and Cotton Belting; Lace Leather;

PHENIX OIL, the only Perfect Belt Dressing.

SEND FOR CIRCULAR.

ALL OUR BELTING IS SOLD AT THE CANADIAN PRICE LIST.

PLEASE COMPARE BEFORE PURCHASING.

Send for Discounts and our Pamphlet on Belting.

**NEW LEATHER BELTING FACTORY,
11 JORDAN STREET.**

Toronto, January, 1888.

TO USERS OF BELTING.

We take pleasure in introducing ourselves to you as makers of

OAK TANNED LEATHER BELTING.

We have our new Factory in operation, and shall be pleased to forward you samples and prices upon application.

Very respectfully yours,

GEO. F. HAWORTH & CO.

as the *Mail* says, by "heavy local taxation and so forth." "Heavy local taxation and so forth" means that every loaf of bread that feeds the hungry stomachs of British farmers and their wives and children, every article of clothing that they wear, and every comfort that they may possess is subject to "heavy local taxation and so forth" for the support of the Government. Canadian farmers would do well to study the condition of British farmers as depicted in the *Mail*, bearing in mind the fact that sorrowful and pitiable as that condition is, it is the result of the system that the *Mail* seeks to have adopted in Canada. "Heavy local taxation" is a painfully definite term that is easily comprehended, but the "and so forth" needs elucidation and explanation.

We congratulate our valued contemporary, the *Winnipeg Commercial*, upon its improved appearance and enlarged size.

Mrs. JOLICOEUR, of St. Patrick street, was the oldest voter who polled a vote on Monday in this city, and probably the oldest lady voter on record or ever likely to be. She is 104 years old next June, and was 31 years of age when the battle of Waterloo was fought. Although the old lady is unable to walk, and very feeble, she managed, with the assistance of a cab, to record her vote at poll 21 for Mayor Stewart.—*Ottawa Citizen*.

The *Illustrated London News* (American edition) maintains the high degree of excellence which it long since attained. It always displays a large number of illustrations which are fully appreciated by all interested in things that are interesting to Englishmen generally, and by means of which very correct impressions and ideas are obtained of the persons, things and places illustrated. The reading matter is always gossip and pleasant, and the installment stories are by well known and able writers. For sale at the book-stores.

The subject of Commercial Union with Canada receives next to no attention whatever in the United States, and we feel sure that an overwhelming majority of the people would object to it were the subject presented to them in its true colors. Were the subject of political union up for consideration the people of this country would no doubt take a lively interest in it, but Commercial Union has never been popular on this side of the line, and at present as we have said, scarcely receives a serious thought outside of a few, who, for some cause, are trying to create an interest in it.—*American Manufacturer, Pittsburg, Pa.*

The progress made by Science within the last fifty years is the most noteworthy phenomenon of recent history. In the work before us—"A Half Century of Science"—that momentous episode finds adequate record and exposition, one of the authors, Professor Huxley, being the foremost biologist of our time as well as a recognized leader of scientific thought; and the other, Mr. Grant Allen, one of the most successful popularizers of the results of scientific research. It forms No. 96 of the Humboldt Library of Popular Science." J. Fitzgerald, publisher, 24 East Fourth street, New York. Price, 15 cents post free.

It seems almost incredible to say that a library fairly representing approximately two thousand of the most eminent authors of the world, of all lands, and of all times, can really be placed within the reach of ordinary homes. Yet this is what is accomplished by Alden's *Cyclopedia of Universal Literature*, volume VIII. of which is now on our table. The work, completed, is to comprise from fifteen to twenty volumes, which are in large type, and really beautiful and excellent in all mechanical qualities, and yet sold at the phenomenally low price of 50 cents per volume for cloth, or 60 cents for half Morocco bindings; even from these prices large reductions being made to early purchasers, and to clubs. John B. Alden, Publisher, 393 Pearl st., New York.

An Ohio manufacturer, who was up-town the other day, said concerning the tariff: "Mr. Cleveland's talk about the tariff increasing the prices of manufactured articles is met forcibly by an illustration from our town. We are heavy manufacturers of nails. You can buy nails in our place for \$38 a ton. The tariff on nails is \$25 a ton. The present price of pig iron is \$16 a ton. According to Mr. Cleveland's idea the purchaser should be paying \$25 and \$16 and the cost of manufacture, besides a profit to the manufacturer. As

a fact, he is paying what nails are worth, supply, demand, cost competition and all figured in. The tariff only preserves to us the United States market—that is all. It shuts out competition with foreign labor."—*New York Tribune*.

An extensive manufacturing company of Cleveland have adopted a novel method for heating their works, which cover an area of seven acres. Air is taken into a blower from out-doors, passes over a coil of steam pipe, and is forced through earthenware conduits underground for several hundred feet. Last winter the method was tried for the first time, and it was successful beyond the expectation of its projector. In the summer the air is forced through the pipes without submission to the steam radiator, and cools the air in the different departments several degrees below the out-door temperature. With this system it is possible to keep an equable temperature in the works, summer and winter. The advantages of the system are economy, good ventilation, and convenience.

FARM mortgages are swallowing up millions of acres of land in the Southern and Western States and Territories. The syndicates that loan money at from 1 to 3 per cent. per month are mainly made up of Scotch, English and New England capitalists, who have their agents throughout the south and west. These mortgages are falling due, and soon an immense number of southern and western farms will be in the hands of foreign mortgagees. It is said that \$200,000,000 have been loaned on farm mortgages in the south-west—in Kansas \$20,000,000, and nearly as much in Nebraska. The territories are covered with mortgages on new farms not yet patented. In some of them the law has permitted outrageous interest, so that the farm mortgage business has grown into immense proportions. In many land districts half the settlers borrow money at high interest to pay the small prices required by the Government on proving up. This is leading to widespread disaster.—*Chicago Times*.

CONVICT LABOR.

Editor CANADIAN MANUFACTURER.

I HAVE read your remarks upon Judge Sinclair's speech to the Grand Jury at the recent Hamilton Assizes, and I am constrained to say that I think the Judge had the right side of the question. Judge Armour's remarks at the Brantford Assizes were in the same strain and are meeting with approval everywhere in this rural district. "Convict idleness" in our gaols is a burden which the honest and industrious classes of the community, and especially farmers, are unwilling to encourage. It is all very well to say that the employment of prison labor will interfere with honest labor outside the gaol, but it must be remembered that the great majority of our population is agricultural, and these have to be taxed to maintain a host of idle vagabonds who commit depredations on the approach of winter for the sole purpose of securing comfortable quarters and good food, without exertion, until spring-time comes, when these "gentlemen of the road" are let loose again, to wander about the country and beg or steal a living during the summer months again. People who live in cities do not understand what is included in the term "tramp nuisance" as we who live in the country do. Our wives and children who are terrorized by these vagabonds can speak eloquently on the subject, and we do demand that some other and more reasonable method of disposing of these gentry be adopted than that of giving them good food and lodging, so good, in fact, that many honest laboring men may well envy them during the winter season.

We do not ask that convicts and tramps be employed at skilled labor. Moulders, carpenters, tailors, shoemakers, nor even lawyers, need be contaminated by contact with tramps, nor their business injured by competition therewith. But bad men, able-bodied convicts, ought to be set to work to improve our roads. Stone-breaking, gravelling, digging and ditching, would only come in competition with the statute labor which Ontario farmers perform most imperfectly and altogether unwillingly, and in consequence of which the condition of our Ontario country roads have not kept pace with the general improvement of the country. Convict labor so employed offers a solution of the question, and I am sure you will agree with me that the able-bodied tramps who so largely fill our gaols during the inclement season could find an excellent field for the exercise of their peculiar faculties. By all means, give our Judges credit for suggesting that able-bodied prisoners ought to be employed, and the few honest laborers who are now engaged in stone-breaking might be engaged as overseers, so that convict competition would not take the bread out of their mouths.

BRANT.

SOUTH DUMFRIES, 9th Jan., 1888.

Manufacturing.

This department of the "Canadian Manufacturer" is considered of special value to our readers because of the information contained therein. With a view to sustaining its interesting features, friends are invited to contribute any items of information coming to their knowledge regarding any Canadian manufacturing enterprises. Be concise and explicit. State facts clearly, giving correct name and address of person or firm alluded to, and nature of business.

MR. J. R. BOOTH is building a new saw mill at Chaudiere Falls, near Ottawa.

MESSRS. CHASE & SON, Hartland, N.B., will rebuild their recently destroyed saw mill.

MR. THOMAS GREENLAW, Vasey, Ont., is about building a shingle mill near that place.

MESSRS. CARR & SHAW, Hartland, N.B., will build a steam lumber mill this winter.

MESSRS. HURDMAN & Co. are building two lumber mills at the Chaudiere, near Ottawa.

MESSRS. MASON & MORGAN, Springbrook, Ont., have put in operation their new shingle mill.

THE Mechanics' Mill Company, Seattle, B.C., lost their new flouing mill by fire Dec. 30th last.

MR. GEORGE AGNEW has commenced the construction of a 35,000 bushel grain elevator at Dominion City, Man.

THE works of the Puget Sound Hide Company, Seattle, B.C., were badly damaged by fire a couple of weeks ago.

THE Hamilton Iron Forging Company, Hamilton, Ont., will increase their capital stock from \$35,000 to \$100,000.

MR. J. C. BEDARD, Hardwood Hill, near Sherbrooke, Que., has finished his new steam saw mill and put it in operation.

MR. RAYMOND, Mitchell's Bay, Ont., will rebuild his lumber mill and also add machinery for the manufacture of staves.

MR. W. H. LAW, Peterboro, Ont., has been awarded the contract for building iron highway bridges at Warsaw and Allendale, Ont.

MESSRS. MORRIS & MORTON's furniture factory, Birmingham, Ont., was destroyed by fire January 14th. Loss about \$7,000.

MESSRS. WILSON BROS., Victoria, B.C., proprietors of the Vancouver Iron Works, have lately completed a new foundry building.

MESSRS. G. H. NICHOLS & Co., Orford, Que., are building new acid works at their copper and nickel mines, which are nearly completed.

MR. JAMES HADDEN, Foxmead, Ont., has completed his new planing mill and put it in operation. He will build a shingle mill this winter.

MESSRS. GOLDIE & McCULLOCH, Galt, Ont., are building a 70 horse power Wheelock steam engine for the electric light works at Cobourg, Ont.

THE Belmont Tanning and Boot and Shoe Manufacturing Company, Victoria, B.C., Mr. William Dalby, manager, give employment to 70 hands.

MR. WM. DAVIDSON, Ridgetown, Ont., has sold his patent in the United States on resonant tube organs, to Messrs. Clough & Warren, Detroit, Mich., for \$3,500.

MESSRS. GOODWIN & JORDAN, Victoria, B.C., manufacturers of pianos, contemplate an enlargement of their works for the purpose of manufacturing organs also.

MR. W. H. MURRAY, Indiantown, N.B., is building an addition to his lumber mill, in which he will place machinery for the manufacture of staves and clapboards.

THE Paris Carpet Works, Paris, Ont., have just been equipped with an incandescent electric light plant. There are fifty lights, and they give great satisfaction.

MR. JAMES DRAKE, Selkirk, Man., is moving his saw mills from that town to Broken Head River, on Lake Winnipeg, and will manufacture oak lumber principally.

MESSRS. N. L. TODD & Co., St. Margaret's Bay, N.B., have one of the largest and finest saw mills in the Province, having capacity to cut 8,000,000 feet of lumber a year.

THE Massey Manufacturing Company, Toronto, manufacturers of agricultural implements, etc., will, it is said, add a malleable iron works to their extensive establishment.

MR. H. BICKFORD, of Messrs. Lennard, Sons & Bickford, Dundas, Ont., manufacturers of hosiery, caps, tuques, etc., was elected mayor of that town at the recent election.

MR. W. P. SAYWARD, Victoria, B.C., proprietor of the Rock Bay Saw Mill, has the only saw mill in that place. It has a capacity to cut 6,000,000 feet of lumber per annum.

MR. J. WEILER, Victoria, B.C., manufacturer of furniture, etc., works 50 hands in an 80x40 three-story factory. Douglas pine and Vancouver maple are largely used in this business.

MR. THOMAS WALLACE, of the Capital Gas Company, Ottawa, has ordered the necessary boring machinery, and boring for natural gas will be begun at once at the Mer Bleu, a few miles from Ottawa.

MESSRS. PERLEY & PATEE, of Ottawa are making extensive alterations and improvements in their lumber mills at the Chaudiere. They are also introducing considerable new machinery into their large saw mill.

MR. JACOB SEHL, Victoria, B.C., manufactures every variety of furniture demanded in that market except common chairs. His factory is 85x64 feet, three stories high, and he gives employment to nearly 40 men.

THE Polson Iron Works Co., Toronto, have received an order to build a passenger steamer to ply between Chatham, Ont., and Detroit, Mich. She is to be 125 feet long, make 16 miles an hour, and will cost \$25,000.

MESSRS. T. B. PEARSON & Co., Victoria, B.C., manufacturers of clothing, denim and duck overalls, cottonade and tweed pants and shirts, etc., give employment to about 25 hands, which number will soon be increased to 40.

THE exportation of phosphate from the mines in the vicinity of Ottawa during 1887 amounted to 20,349 tons, against 19,298 tons during the previous year. There is a large demand for high grade Canadian phosphate in English and German markets.

THE factory at Hespeler lately owned by Messrs. Harvey & McQuesten, of Hamilton, has started to run out the stock of woolen yarns now on hand, thereby giving employment to perhaps 40 hands for a period of two months. — *Guelph Herald*.

MESSRS. GEORGE FLEMING & SONS, St. John, N.B., have contracted to build two six-wheeled locomotives for the Joggins railroad. They have just finished an elegant new locomotive for the Central, and are rebuilding two for the Intercolonial.

A VALUABLE discovery of silver, about twelve miles from Sault St. Marie, Ont., is reported. The vein is five feet thick, and two shafts are being sunk. It is said that a company, with a capital stock of \$500,000, has been formed to work the property.

MR. WM. SUTTON, of Walkerville, Ont., is the owner of an extensive saw mill plant located at Cowichan, Vancouver Island, B.C., which has a capacity to cut from 15,000,000 to 20,000,000 feet of lumber a year, and which has been idle for about two years.

MRS. JOHN GUEST, Wichita, Kansas, during her twenty years of married life, has given birth to twenty-two children. On two occasions she gave birth to twins and once to triplets. So much for home industry and a protective policy which gave Mr. Guest constant employment at home.

TIMES at the Acadia Mines, N.S., are looking much better. The rolling mill goes on double time next week, and the manager is rushing along additions to the foundry for the purpose of casting water pipes, for which they have contracts amounting close on to \$200,000. — *Moncton, N.B., Times*.

MR. D. G. McMARTIN, of Ottawa, is opening up several new and valuable mica mines in the vicinity of Perth, Ont. Specimens of the mica taken from these mines show it is of a good quality, and it is in large quantities. Mr. McMARTIN intends working his new mines extensively the coming spring.

MR. WILLIAM HEATHORN, Victoria, B.C., manufacturer of boots and shoes, occupies two floors of a large building as his factory, each 90x60 feet, besides storage room elsewhere. He gives

employment to about 70 hands. He will considerably enlarge his premises and put in additional machinery.

THE agricultural implement factory of Messrs. John Larmonth & Co., Montreal, was gutted by fire January 6th, loss about \$10,000. The stock burned was a valuable one, consisting principally of wood sawing attachments, and a large quantity of tools and threshing machines in course of construction.

THE Canadian Lumber Cutting Machine Company of Toronto, who are erecting extensive works at Belleville, Ont., are in receipt of three car loads of machinery for their works, two car loads more being expected daily. They are making rapid progress in getting their works into working order.

MESSRS. N. C. PETERSON & SONS, Sarnia, Ont., manufacturers of machinery, stationary and portable steam engines and boilers, etc., have just received a large consignment of steel boiler plates, imported by them to be manufactured into boilers for their portable and traction engines, of which they make a specialty.

CONSIDERABLE new machinery is being introduced into the Banff coal mines which will enable the company to increase their output about 300 per cent. Large quantities of Banff coal are being shipped via the Canadian Pacific railroad and Vancouver to San Francisco and other points in California and Oregon.

MR. WILLIAM STEVENSON, Petrolia, Ont., is manufacturing two new steel marine boilers, each 10 feet 4 in. by 12 feet for the steamer formerly known as the *Frances Smith* but which will be hereafter called the *Baltic*, belonging to the Great Northern Transit Company, and now being rebuilt at Collingwood, Ont.

MESSRS. GEO. F. HAWORTH & CO., Toronto, in addition to their manufacturing business, have been appointed exclusive agents in Canada for the sale of Hoyt's pure American oak tanned leather belting, known the world over for its superior quality, and which has been used by some of the largest mill owners in Canada for the past thirty years.

THE Papineauville, Que., town council have passed a resolution to the effect that no taxes shall be levied for fifteen years on any manufacturing or industrial enterprises that may be started there. It is said that Messrs. McLachlan Bros., of Arnprior, Ont., and Messrs. John Gillies & Bro., of Braeside, Ont., will erect lumber mills at Papineauville.

MESSRS. McOUAT & McRAE, proprietors of the Victoria Brass and Iron Foundry, Lachute, Que., inform us that they are operating their works full time and have plenty of business. Their lines of manufacture include stoves, plows, cultivators, sugar boilers, land rollers, harrows, road scrapers, hot air furnaces, etc. They also make and repair every description of machinery.

MESSRS. P. W. ELLIS & CO., Toronto, manufacturing jewelers, shipped this week several important orders of silver winter sports jewelry to St. Paul, Minn., where an ice carnival is to be held beginning January 28th inst. These beautiful novelties are all of original designs, and are manufactured only by this firm, who are building up quite a large trade in this line.

SEVERAL new locomotives built in the Kingston, Ont., locomotive works have arrived in Moncton and are being put up in the I.C.R. shops. These locomotives are larger and heavier than any in use at present on the Intercolonial and will be principally used for freight traffic. Messrs. Dubbs & Co., of Glasgow, Scotland, are also building locomotives for the same road.

THE total shipments of coal by Messrs. Dunsmuir & Sons, of the Wellington, B.C., collieries, for the month of November, aggregated 23,832 tons, representing an output of nearly 1,000 tons for each working day. Of this large aggregate, 17,309 tons were shipped foreign and 6,523 tons were local shipments. It is expected that even this large output from the Wellington collieries will be still further increased.

WE are informed that a company is now being formed in Toronto who will acquire an extensive and well located property at Niagara, Ont., near the mouth of Niagara river, and establish a large works for the manufacture of heating furnaces and similar goods, including malleable iron. A railroad switch is already laid on the premises, and a wharf already built on the property gives unequalled facilities for water transportation.

DURING 1887 three concerns made shipments of Canadian raw phosphates to Europe, as follows:—Messrs. Lerner, Rohr & Co., of Montreal, 8,744 tons, the product of the Emerald, Dominion and McLaurin & Blackburn's mines, Messrs. Wilson & Green, of

Montreal, 7,468 tons, from the mines of the Phosphate of Lime Co.; Mr. Boyd Smith and Mr. W. A. Allan and the Anglo-Canadian Phosphate Company, 2,025 tons.

MESSRS. JAMES HARRIS & CO., whose car works and rolling mills are located in Portland, St. John, N.B., have on hand orders for railway cars, railway wheels and heavy iron work amounting to \$600,000. We understand that the wages paid out by this firm and by Parks' cotton factory, in the same town, are greater in volume than what was disbursed in wages by all the shipyards in St. John when ship-building was in its prime.—*Empire*.

THE shipments of cotton goods from the Marysville, N.B., mills are rapidly increasing in number and weight. There have already been shipped this week about 75 cases of colored goods and 75 bales of greys, and 100 cases and a like number of bales are now loading. The average shipment per day for the past eight or nine days has been about ten tons.—*Fredericton Gleaner*. The mills here alluded to are those of Mr. Alexander Gibson.

MR. C. F. HUNGER, representing the Adjustable Chair Company, Cleveland, O., has arranged with Messrs. Heeps & Co., Oshawa, Ont., to manufacture their adjustable chairs for the Canadian market. Mr. Hunger is the inventor of this adjustable chair, which is now patented both in the United States and Canada. The article has met with great favor in the United States, as many as 90,000 of them having been sold in one year.

MR. SAMUEL GRAY, Victoria, B.C., is the proprietor of a large establishment employed in the manufacture of sash, doors, mantels, mouldings, hand rails, newel posts, etc. He is the patentee and manufacturer of an improved self-supporting stairs, in which is embraced a stair, elevator, light shaft and ventilator, a unique contrivance for economizing room, and in the sale of which he is doing a prosperous business in Oregon and California.

MR. L. SCHEPP, of New York, probably the most extensive manufacturer of desiccated cocoanut in America, and whose goods are on sale in all respectable groceries in the country, has decided to start a branch manufactory in Canada, and is now looking about for a favorable place to locate, his preference being either Toronto or Hamilton. A suitable flat with steam power is required, and those having such facilities to let should act on this information.

THE Dodge Wood Split Pulley Co., Toronto, Canadian manufacturers of the Dodge patent wood separable or split pulleys, and of the Dodge system of rope transmission of power, are equipping the works of the Massey Manufacturing Company, Toronto, with a series of such transmissions. There are four different transmissions taken from the main line of shafting—one of 30 horse power, one of 20, one of 18 and one of 5. The company report that they are very busy on this class of work.

IT is said that when Kennedy & Bunston applied to the town council of Walkerton for a bonus to aid them in the manufacture of woolens and received \$4,000 they launched out into heavy expenditures on account of machinery, etc. The un wisdom of this course is emphasized by their failure, just announced. The liabilities are stated at \$28,000 and assets \$8,000 to \$10,000. No little unfavorable comment on the bonus system is now being indulged in throughout the town.—*Monetary Times*.

PROF. GEO. H. THOMPSON, of Reading, Pa., has just had patented "a life-saving brick." The invention consists of a hollow steel brick. The bricks are to be firmly cemented and anchored in the front wall of any building, two feet apart, running from bottom to top. They are so constructed that a fireman or anyone can touch them in front and instantly a steel rung of a ladder pushes itself out. The man can climb up any height securely and safely, as the steel steps are strong enough to bear a ton.

ENGINES No. 170 and 194, for the Intercolonial railroad, reached Moncton last week from the Kingston works, and were on Saturday submitted to a test which proved very satisfactory. These are freight engines of the heaviest type, and are the first of a lot of a dozen or more for which the Kingston works secured the contract some time ago. No. 170 takes the place of the engine destroyed by the explosion at Stellarton. Engines are greatly needed for the increasing freight traffic.—*Moncton, N.B., Times*.

A MEETING of citizens will be held on Tuesday evening next in regard to the formation of a joint-stock company to start a boot and shoe factory in the city. Mr. Kelly, formerly of the Caledonia factory, who is the prime mover in the matter, is the patentee of a celebrated seamless shoe upon which he gets a handsome royalty in the States. There is no reason why successful works should not be started in Brantford forthwith. Many business men have already stated their intention to take stock.—*Brantford Courier*.

MR. E. R. MOORE, one of the most prominent manufacturers in the Maritime Provinces, fell dead at his home in St. John, N.B., Jan. 8th. He was proprietor of the Coldbrook rolling mills, two miles from St. John, and of the nail works, and also of Moore's nail factory in St. John. These establishments employ from a hundred to a hundred and fifty men. Mr. Moore was 57 years old. He commenced the manufacture of nails and spikes in 1862, and claimed to have been the first manufacturer of steel nails in Canada.

THE St. John *Sun*, speaking of the work done in the cotton factories in the Maritime Provinces in 1887, says that there is an aggregate of 132,000 spindles and 2,640 looms in them, and that having run forty-five weeks during the year they produced 24,525,000 yards of cloth and 7,470,000 pounds of yarn and cloth, the number of hands employed aggregating 1,920, and the value of the output \$1,850,000. The mills alluded to are those of Messrs. Wm. Parks & Son, Gibson's, St. Croix, Moncton, Windsor, Halifax and Yarmouth.

MESSRS. GALE & SONS, Waterville, Que., manufacturers of wire mattresses, etc., employ about 60 hands in that business alone, while in the outside, lumbering in winter and building in summer, they average about 225 persons in their employ. To meet the requirements of their rapidly increasing trade they require and use 500,000 feet of hard wood plank and a similar number of feet of boxing during the year, and 200 tons of the best Bessemer steel wire, from which they turn out every month 1,500 wire mattresses, besides 100 woolen mattresses.

A FEW weeks ago gas was discovered on the Simpson farm near Sarnia, Ont., in such quantities as to prevent drilling. Indications of the presence of oil were also found, and a few days ago a pump was put in and oil discovered in large quantities. The well is now pumping at the rate of 60 barrels a day, with the quantity apparently not diminishing. The escaping gas is utilised to furnish fuel for the boiler. The well has been visited by gas and oil experts who pronounce the supply to be more than four times as great as that from the best Port Huron wells.

THE Magog Textile and Print Company, Magog, Que., have recently received fifteen car loads of machinery for their new mills at that place, the first of a consignment which will aggregate more than 900 tons in weight. The carding engines are being manufactured by Messrs. Ashworth & Co., Manchester, Eng., and the balance of the card-room machinery by Messrs. Asa Lees & Co., Oldham, Eng.; the spinning machinery by Mr. Samuel Brooks, Manchester, Eng., and the looms and preparation machinery by Messrs. H. Livesey & Co., Blackburn, Eng.

MR. B. H. BUCKRAM, of London, Eng., a wealthy capitalist, has just purchased from Mr. W. A. Allan, of Ottawa, the controlling interest in the Villeneuve Mining and Mica Company's mines at Villeneuve, in the county of Ottawa. These mines are some of the most extensively worked mica mines in the Province of Quebec, and the mica taken out is of an unusually clear and firm nature, standing the highest fire test. Large quantities of this mica have recently been shipped to Boston and other points in the New England States, where it is used by stove manufacturers.

THE shipments of coal from Nova Scotia mines during 1887 were over 1,500,000 tons, an increase of 150,000 tons over the previous year. Of this increase, 129,000 tons were from the Cape Breton mines. The shipments from the respective coal fields were as follows:—Cumberland, 469,000 tons; Picton, 338,000; Cape Breton, 717,000; total, 1,524,000. This is more than double the entire shipment before the National Policy. Great preparations are being made for much larger shipments this year. The Springhill shipments in 1879 were 90,000 tons; in 1887 they reached 470,000 gross tons.

Two years ago the Nova Scotia Sugar Refinery Company, whose works are at Halifax, N.S., and whose capital stock was \$350,000, was a bankrupt concern and a complete loss to the original stockholders. A few stockholders having faith in the sugar industry bought it from the Merchants Bank, which held a mortgage on it for \$250,000, and which the bank regarded as a very doubtful asset. During last year the company made about \$150,000 profit upon an output aggregating \$2,000,000, paid 13 per cent. dividend and paid off part of its mortgage. Some 60,000,000 pounds of sugar were imported into Halifax during the year, which paid nearly \$600,000 duty.

THE Albion Iron Works Co., Victoria, B.C., which was established by Mr. Joseph Spratt in 1862, and incorporated in 1882, have one of the largest and most important plants on the Pacific coast. Their machine shop is 250x50 feet, two stories high; stove foundry, 110x60 feet; machinery foundry, 90x50 feet;

foundry for miscellaneous work, 100x50 feet; brass foundry and shop, 65x30 feet; blacksmith shop, 90x50, and boilermaker's shop, 240x50 feet. They manufacture railway work, mining machinery, steam engines for all purposes, boilers, stoves, etc. They employ about 150 hands. The coal they use is brought from Pennsylvania by ship via Cape Horn.

MESSRS. GALE & SON, Waterville, Que., manufacturers of wire and wool mattresses, etc., have nearly completed the construction of their new factory, and expect to occupy it at a very early day. The building is 80x5 feet five stories high, with a 48x28 feet engine, boiler and drying-room, all of brick. During last year this firm supplied nearly 1000 of their combination mattresses to different institutions for the Ontario Government, and sent about 8000 wire mattresses to Great Britain, besides making large shipments to Bermuda and Alaska. They are preparing and will send a comprehensive exhibit of their manufactures to the forthcoming Melbourne, Australia, Exhibition, at which city a member of the firm will permanently reside.

MESSRS. E. L. FENERTY AND S. M. BROOKFIELD, Halifax, N.S., are the proprietors of the Halifax Shovel Company, lately known as the Halifax Manufacturing Company. They are sole makers in Canada of Fenerty's patent socket shovel; and although the article has been in the market but a little more than a year it is meeting with most flattering success, and has acquired an established reputation in the Maritime Provinces. This company have been carefully perfecting the shovel and methods of manufacture, and are increasing their facilities with a view of ultimately reaching all parts of the Dominion, the demand from the Lower Province being such as would not warrant them in attempting to supply the western markets without increasing their capacity.

MESSRS. L. J. WILSON & Co., Dutton, Ont., as will be remembered, suffered the loss of their woolen mills at Union some time ago, which circumstance led them to determine to suspend operations at their Dutton mills, except during the carding season. We learn that the firm have now decided to rebuild their Union mills, and continue their Dutton mills in constant operation, and close their works at St. Thomas. They have prepared the plans for their proposed buildings at Union, which are more modern and will far exceed the old mills. When completed the mills will cost in the neighborhood of \$20,000. The machinery will be the most improved, and yet it will not cost as much as the old, it being much cheaper now than when the other was purchased.

MESSRS. WM. PARKS & SON, St. John, N.B., proprietors of the New Brunswick Cotton Mills and the St. John Cotton Mills, are calling the attention of the readers of this journal and the trade generally to some of the lines of goods manufactured by them. They specially mention white and colored cotton yarns Nos. 5 to 10; white and colored cotton carpet warp; ball knitting cotton in all numbers and colors; cotton hosiery yarn suitable for the manufacture of hosiery; grey cottons in a variety of grades; fancy wove shirting in several grades and new patterns; seersuckers in stripes and fancy checks; cottonades in plain and fancy patterns, etc. Their general agents in Canada are Mr. Duncan Bell, at Montreal and Quebec, and Mr. William Hewett, at Toronto.

A REPORT is current that efforts are being made by the business men of Stratford, Ont., to induce Messrs. Maxwell & Sons, of Paris, Ont., to remove their agricultural works to that city. Regarding this the *Paris Review* says that it remains with the people of Paris to ascertain whether the inducements to the concern to go to Stratford cannot be offset by inducements on their part for the concern to remain where they are, and thinks that some action should be taken by the town council "to avert such a calamity." This is another forcible illustration of the evils of the bonusing craze that possess some Ontario towns. A perambulating bonus-hunting concern can never be of much value to any community, nor will the tall chimneys of their factories ever be permanent features of any landscape.

FOLLOWING are the Customs Department decisions for December, 1887:—Almond paste, 1½c. lb. and 35 p.c.; bird skins, 20 p.c.; borax, ground, free; composition fuel, in blocks, 20 p.c.; cotton covered flat-steel, cut to lengths, with brass on ends and eyeleted, as parts of clothing, 35 p.c.; canvas, painted and stretched on frame, for artists' use, 25 p.c.; Dutch or schlag metal leaf, 30 p.c.; duck, printed and dyed, as printed cotton, 32½ p.c.; fire clay vents or chimney linings, not vitrified or glazed, 20 p.c.; non-elastic web, for suspenders, 20 p.c.; printed wrappers, as labels, 15c. lb. and 25 p.c.; spindle bands, cotton cord, as cordage, 1½c. lb. and 10 p.c.; sheet iron signs, not framed, 30 p.c.; sauce, in bulk, 40c. gal. and 20 p.c.; suspender ends, 35 p.c.; trunk trimmings, of tinned iron, 30 p.c.; tin buckles for suspenders, 25 p.c.

SPRINGHILL, N.S., is an important mining town on the line of the Springhill and Oxford railway, and, when that road is completed, will be the central point connecting the Basin of Minas and the Gulf of St. Lawrence. The collieries there were opened in 1873, contemporary with the completion of the Intercolonial railway. The output of coal that year amounted to 3,274 tons, and in 1874 to 34,000 tons, since which year the output has steadily increased, until in 1887 the production amounted to 470,000 gross tons, or more than 526,000 net tons of 2,000 pounds. Over 1,400 men and boys are employed in and about the mines, and preparations are being made to largely increase the output. During last year a new machine shop was built at these mines which is 120x60 feet, and thoroughly equipped.

ONE New Brunswick firm sells in the Upper Provinces annually about \$100,000 worth of brass goods of its manufacture, such as steam injectors, pop valves, check valves, globe valves, etc. Nearly all the forgings used in the locomotive works at Kingston this year will come from New Brunswick and Nova Scotia. Car-axles used in the Grand Trunk and Canadian Pacific shops are being obtained from the same quarter. Ten thousand tons a year of nail plate is made in St. John, N.B., and the product in spikes, nails, tacks, etc., is sold chiefly in the Upper Provinces. The bar iron made at St. John, N.B., and Londonderry, N.S., finds its market mainly in Quebec Province and the West. The steel for ploughs and other agricultural implements manufactured in Ontario comes largely from Nova Scotia.—*Empire.*

Messrs. A. ROBB & SONS, Amherst, N.S., inform us that their works are exceedingly busy at this time, and that they are crowded with orders. They have recently shipped one of their celebrated Monarch steam boilers to the Caribou gold mines, in Colchester county, that Province, and a pair of boilers to Mr. B. B. Barnhill, Two Rivers, these latter being the full length of the car on which they were loaded. They have also shipped a carload of machinery to Mr. Barnhill which included a Robb celebrated rotary mill. The new school seat made by this firm is being introduced into a number of new school houses in the Province, and give entire satisfaction. They are inexpensive, and are substantial and convenient. The firm are meeting with great success with their iron cresting for roofs and windows, the article being shown in a number of new and beautiful designs.

MR. PHILIP BOURQUE, Moncton, N.B., is organizing the St. Anselme Manufacturing Company, in that place, with a capital stock of \$10,000, for the purpose of manufacturing lumber, furniture, grinding flour, etc. The property the new company will acquire consists of 350 acres near Moncton, on which is an abundance of birch, beech, maple, ash and poplar, woods now largely used in the manufacture of furniture, as well as pine, spruce and hemlock for general milling purposes. There are works on the property which embrace a gang saw mill, with circular, edgers, three sets of trimmers, haul-up wheel, lath and shingle machines with Leffel double turbine water wheel; also a grist mill with two runs of stones, patent French burr, with smutter, elevator, etc. In connection with the above it is proposed to commence the manufacture of cheap furniture, chairs, tables, bedsteads, etc., at once, the business to be extended as may be thought desirable.

ST. JOHN COTTON MILLS.—This firm is composed of Wm. Parks & Son (Ltd), cotton spinners, dyers, bleachers and manufacturers. Two mills, both in St. John, N.B., one named the New Brunswick

Cotton Mill, and the other the St. John, N.B., Cotton Mill. The New Brunswick cotton mill was established in 1861 in a small way, and is the oldest mill now running in Canada. It is running upon cotton yarn of different classes, shirtings, cottonades, seersuckers, and goods of that class; turns 20,000 spindles, with a production of 30,000 lbs. weekly. The St. John cotton mill has now running 12,000 spindles, with room for 8,000 more, and 300 looms, with a production of 20,000 lbs. a week, nearly all grey cottons, and the number of hands employed altogether is over 500 in the two mills, drawing weekly wages to the amount of \$2,500. Goods are sold all over the Dominion, and a small quantity exported, export trade gradually increasing. Their production, next to the Hochelaga Mills, claims to be the largest in the Dominion. They dye about 20,000 lbs. a week.—*Halifax Critic.*

A NEW departure in the transmission of power by manilla ropes, as used in the Dodge system, is that in use at a flouring mill at Buchanan, Michigan. This mill is operated by water power, and the stream does not furnish sufficient water at all times for their 35 horse power wheel, but the transmission alluded to enables them to utilize the power of the water again from a dam 1100 feet down the stream, where a 25 horse power wheel has been placed. A pulley is placed on the shaft of the last named wheel and from this the rope travels first to a pair of mule pulleys on the first power, set on rising ground just above the bank of the pond. From these mules the rope passes in a straight line to the main transmission pulley on a counter shaft at the mill, and intermediately supported on six set of bearers. This counter shaft is belted to the main line shaft and is provided with a clutch, so that the transmission may be connected or disconnected at will. This shows that it is possible and easy to use the water over and over, and that the lay of the ground is of small importance.

MR. W. H. LAW, proprietor of the Central Iron and Bridge Works, Peterboro, Ont., has recently moved into his new works in that city, which are among the most commodious of any similar works in Canada, covering as they do about 2½ acres of ground. The blacksmith shop is 90x40 feet; the larger machine shop, 156x58 feet; the office building, 30x30 feet; iron house 60x28 feet, and coal house, 60x15 feet. The blacksmith shop contains among other machinery, six forges, a No. 4 blast fan which makes 2,500 revolutions a minute, and a ponderous steam hammer. The machinery in other departments consist of an automatic bolt cutting machine, heavy and light punching machines, both horizontal and vertical; shearing machines for both plate and bar iron; straightening machine; sawing machine, for sawing cold iron or steel, capable of sawing iron 8½ inches thick by 24 inches wide; drilling machines; horizontal borers; lathes, planers, shapers, etc. A direct action hydraulic riveter for these works is being built in England, which, it is claimed, will be the only one of the sort in Canada.

MR. W. H. RUSSELL, of Miramichi, N.B., has invented an elevator and tramway for loading and discharging ships' cargoes, which consists of a light wooden framework supporting a continuous belt to which, at suitable intervals, are attached iron tables on which to place the merchandise, similar to the buckets on a grain elevator. The package is placed on one of these tables and is quickly carried to the level of the deck, where it is transferred without manual labor to a series of endless bands or belts, which convey it at once to the shed. By means of this invention one man is able to do the work of four, and in far less time. There will be no need to erect the staging at present used in discharging and loading

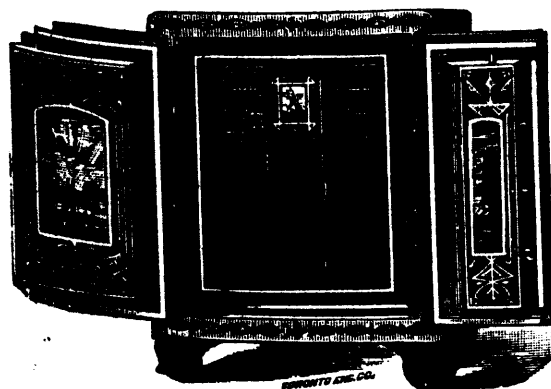

J. & J. TAYLOR'S

Double Tongue
and Groove
FIRE-PROOF

SAFES

(Patented
January 14th,
1886.)

Established 33 years.

All our new style Fire-proof Safes are fitted with TWO COMPLETE TONGUES AND TWO GROOVES on both the door and door frames, which effectually prevent the heat from passing between the door and frame into the interior of the safe.

They are also fitted with CHILLED CHROME STEEL PLATES under the Lock and Bolt Spindles to prevent drilling; and have DRY AIR-CHAMBER inside to prevent dampness to papers.

See Catalogues and Prices on application.

J. & J. TAYLOR, Toronto Safe Works.

steamers, as all that will have to be done is to adjust the elevator to the depth of the hold as required and hoist away as quickly as the men can place the packages on the elevator, the motive power being supplied by the ship's donkey engine. This invention, it is claimed, will work a revolution in the stevedore business, and that by means of it a steamer can be unloaded with less than half the labor now required and in one quarter of the time.

MESSRS. P. W. ELLIS & Co., Toronto, manufacturing jewelers, have just set up a new machine in their works at a cost of over \$1,000 for the manufacture of metal collar buttons made in one piece. Originally metal collar buttons were composed of seven distinct pieces, and, as useful as the article was, all users are aware of the annoyance experienced through their frailty. Improvements in processes of manufacture from time to time made it possible to reduce the number of pieces composing the button first to five and then to three pieces, but even then soldering the parts together by skilled workmen was essential. The machine here alluded to is a recent invention, and works automatically, the original disc of metal on being fed into the machine going through a series of manipulations which produce the finished article with remarkable speed. Instead of skilled attendants the services of an intelligent girl is all that is necessary in operating the machine, and the great saving of expense by its use enables the manufacturers to sell this superior and desirable button in Canada at just the same price heretofore obtained for the multi-parts and objectionable old button.

MESSRS. WAGNER, ZEIDLER & Co., Toronto, manufacturers of piano and organ key-boards, and dealers in piano and organ materials, have bought out and amalgamated with their concern the business of the Dominion Show Case Company, of this city, and the concern is now known as the Dominion Show Case Works. In August last Mr. J. P. Wagner, senior member of Messrs. Wagner, Zeidler & Co., retired from the concern, and Mr. David C. Wagner, his youngest son, was admitted a partner. Shortly after the reorganized firm, consisting of Messrs. George P. Wagner, Carl Zeidler and David C. Wagner, bought out the business of the Dominion Show Case Company, as above stated, in which Mr. J. P. Wagner was largely interested, and with which Mr. David C. Wagner had been connected for several years. The new concern—the Dominion Show Case Works—are now carrying on the business of manufacturing piano and organ key-boards; all styles of show cases; all kinds of office desks and furniture; mantels, counters, store fittings, etc. Their city office and show and warerooms are at 40 Yonge street, and their extensive factory at West Toronto Junction, near this city.

A MEETING of the shareholders of the W. F. Cochrane Roller Mills Supply Company (Limited), who have acquired the patents for Canada and England for the construction of roller mills for grinding wheat under the new process, was held in Hamilton two weeks ago. The company was organized with the following directors: Messrs. W. F. Cochrane, of Washington D.C.; Charles Rioridan, of Toronto; C. M. Counsell, J. M. Gibson, M.P.P.; V. E. Fuller, F. S. Mallock, and Robert Thompson, with power to add two to their number. Additions to the buildings at Dundas were reported as being well on the way, and the machinery that is being turned out by Messrs. Bertram & Sons, Dundas, is as, to part of it, ready for delivery, the balance to be completed this month. Applications for these mills are being received from all over the country as well as in the United States. The company propose making all classes of chilled rolls, and have secured for that purpose competent hands who have had a long experience in one of the best chilled roll making establishments on this continent. The head office of the company will be in Hamilton and the works at Dundas. At a subsequent meeting of the directors, Mr. Valancy E. Fuller was appointed President and Mr. C. M. Counsell, Vice-President.

THE only attempt so far made to utilize Canadian phosphate at home have been at the fertilizer factories in Brockville and Smith's Fall, Ont. The factory at Smith's Falls was established originally for the manufacture of chemicals of various kinds, but a few years ago the production of fertilizers was tried as an experiment, and as a very good article was made, with no adulterations, it got a good name and the demand has been steadily increasing. Mr. Brodie, B.Sc., a graduate of McGill College, has charge of the works, which are controlled by Messrs. Brodie & Harvey, the well-known flour and milling firm in Montreal. Mr. Brodie states that he makes the sulphuric acid from pure sulphur. He gets rid of the hydrofluoric acid gas, which is produced by the action of the sulphuric acid on the apatite, by a simple arrangement of wooden chimneys, thus solving a difficulty which has embarrassed many persons in their first efforts to use Canadian phosphate. He makes a "complete fertilizer," that is, a mixture of the three principal

ARMSTRONG'S BUGGY AND CARRIAGE GEAR.

The "Defiance"

THIS GEAR meets the demand of the Driving Public for low-riding Buggies, and combines with this, lightness, durability, and great ease of motion. By the use of improved machinery and manufacturing in large quantities, we are enabled to make prices MODERATE. Send for our descriptive circular.

J. B. ARMSTRONG MFG. CO. (Ld.), Guelph, Ont.

ST. CATHARINES SAW WORKS.



R. H. SMITH & CO.,

ST. CATHARINES, ONT.,

Sole Proprietors, in Canada, of the

"Simonds" Saws
AT GREATLY REDUCED PRICES

All our Goods are manufactured by the "Simonds" process. Our Circular Saws are unequalled. We manufacture the Genuine Hanlan, Lance Tooth, Diamond, New Improved Champion, and all other kinds of Cross-Cut Saws. Our Hand Saws are the best in the market, and as cheap as the cheapest. Ask your Hardware Dealer for the St. Catharines make of Saws.

THE LARGEST SAW WORKS IN THE DOMINION.

ingredients of plant food, namely, phosphate, potash and ammonia. The demand is growing in a very encouraging manner, and Mr. Brodie says he could sell 1,000 tons the coming year if he could make it, but the factory is small and the facilities not very great.—*Canadian Mining Review.*

MESSRS. F. E. DIXON & Co., Toronto, manufacturers of patent lap-joint star rivet leather belting, address themselves through these pages to mill owners, manufacturers, and all who use leather belting, proclaiming the excellence of their products and the great variety in which they are made. They speak of their belting as that which will run straight on the pulleys, thoroughly well stretched, will not tear at the lace holes, and which will give entire satisfaction. They manufacture their leather belting from the very best Canadian and American genuine oak-tanned leather, and they are also large dealers in rubber and cotton belting, lace leather and Phenix oil, which they say is the only perfect belt dressing made. They ask that any interested will write to them for their price lists and discounts, and for their pamphlet on belting, which they will take great pleasure in sending. The pamphlet alluded to, in addition to other valuable matter relating to the subject, contains some useful hints to users of belting, in which is shown the per cent. of resistance on different pulleys, etc.; value of rubber and canvas belts as compared with leather; strength of belts; care of belts; directions for calculating the width of belts required for transmitting different amounts of power under different circumstances, and for calculating the amount of power which a belt will transmit; general maxims in regard to belts, etc.

MESSRS. J. & J. TAYLOR, Toronto, proprietors of the Toronto Safe Works, are constructing for the Canadian Bank of Commerce for their new head office now being erected at the corner of King and Jordan Streets, this city, what will probably be the largest and heaviest fire proof bank vault in the country, the weight of which will be over fifty tons. This vault is being constructed according to the latest and most approved methods, and of the best materials, calculated to insure security and protection against both burglars and fire. The heavy frame plates are all welded and bent to shape solid at the corners, and are of the best quality 5-ply chrome steel. These frames, after being shaped and fitted, are taken apart and

subjected to a process of tempering, chilling and hardening, which enables the metal to resist all attempts at drilling. The vestibule and the frames of the inner and outer doors are constructed of the same materials and similarly treated, and are very heavy, the entrance alone weighing some six tons. The doors are tongued and grooved, and are made proof against the introduction of explosives by the use of the J. & J. Taylor improved rubber tube packing. They are supported on crane hinges, heavy cams being used for forcing them into position. The remarkably delicate and effective combination locks for this vault, with electric and automatic connections, are also being constructed by Messrs Taylor.

Messrs. GEO. F. HAWORTH & Co., Toronto, have gotten their machinery, tools, etc., into their new leather belting factory at 11 Jordan street, and are now fully under way. These works occupy a four-story brick building 100x25 feet, the motive power being a 25 horse power steam engine and a 35 horse power boiler. All of the machinery and appliances in this factory are of American manufacture, and of the latest, best and most approved character. On the ground floor, where the crude material is received, is a new pattern Fitzhenry Boston scouring machine. Leaving this the leather is conveyed by elevator to the top floor, where it is curried, dried and stretched; thence it is sent down to the next floor where the balance of the work is done. The machinery includes besides the scouring machine alluded to, a 40-inch power press, scarfing machines, trimming and finishing machines, rivetting machines and every other appliance necessary for making and finishing the belting. The stock room, shipping department, offices, etc., are on the main floor, and are most conveniently arranged. The offices are commodious and very nicely furnished, and the entire building is heated by steam. All of the workmen employed in this factory are old and experienced hands, and were brought by Messrs. Haworth & Co. to these works from some of the oldest belt making establishments in the United States. Mr. Haworth, the head of this concern, has had many years of experience in the belting business in Toronto and is well known to the trade; and the enlarged facilities which his concern have acquired places them in a first class position to do an extensive trade.

The Lake of the Woods Milling Company's great 1200 barrel a day flouring mill, now being built at Keewatin, Ont., by Messrs. C. P. Allis & Co., Milwaukee, Wis., is being rapidly pushed to completion. The machinery is being built at the Allis works in Milwaukee, and the power which is to drive it is obtained from two 60-inch new American water wheels, furnished by Mr. Wm. Kennedy, Owen Sound, Ont. These wheels will develop 900-horse power with a 22-foot head of water. In the wheel house is a Fales & Jenks rotary fire pump, which has a capacity of 900 gallons per minute under 150 pounds pressure. The main building is 85x50 feet, divided into three separate parts by heavy granite walls, and there is a 50x25 foot addition on the east and a 110x50 foot addition on the west. The basement walls of the mill building proper and cleaning room are 4ft. thick at top and 5ft. thick at the bottom, resting on footing courses 8ft. wide, which are down to the solid rock. The basement walls of the warehouse are 3ft. at top and 4ft. at bottom, resting on footing courses 6ft. wide, which are also carried down to the solid rock. Fire protection is provided for by water contained in a tank on the roof, which tank operates the sprinkler system, one of which is placed over every bearing in the mill and one in each elevator head. By a system of check valves, the tank can work direct on the sprinkler system or the hose, and as soon as a sprinkler starts in operation it rings an electric gong in the wheel house, which notifies the employes and sets the pump to work. As was reported in the last issue of this journal, over two miles of the belting to be used in this immense mill was sent from the leather belting factory of Messrs. Geo. F. Haworth & Co., of this city.

WILLIAM BELL & CO.

Messrs. Wm. Bell & Co., Guelph, Ont., manufacturers of organs, are now building and have nearly completed another addition to their extensive factories—a five-story brick building 91x26 feet. This is the second large addition made to these works within a year, the firm having last fall erected a four-story brick building 110x40 feet, as was mentioned in these pages at the time.

Mr. William Bell started in the business of manufacturing this class of goods in Guelph in 1864. The beginning was a small one, two workmen being the extent of the force employed, and the output for the year being only about twenty-five melodeons. The increase of this business from that time to the present has been most rapid and exceedingly gratifying. In 1865 the concern moved into larger and better arranged premises, and manufactured 200 instru-

WM. LAURIE & CO.

MANUFACTURERS OF

SPOOLS AND BOBBINS

OF ALL SIZES AND PATTERNS,

FOR COTTON AND LINEN THREAD, MACHINE TWIST, SEWING SILK, AND FOR COTTON, WOOLEN AND SILK MANUFACTURERS.

LOUISEVILLE, P.Q.

We respectfully solicit your patronage and guarantee our work to be first-class.

To Users of Glue.

WE are manufacturing a reliable GLUE, and can supply a limited number of consumers only. We guarantee our glues to be made from selected stock, and to be of the same uniform quality. Glues not as represented, or not proving satisfactory, returnable at our expense.

JAMES HAY & CO.
WOODSTOCK, ONT.

ments during the year; but the big growth of the business began in 1878, since which time it has ceased to be an infant industry and has acquired a robustness that makes it probably the largest of the sort in the Dominion, and the equal of any on the American continent. These works now embrace two large factories which have an aggregate floor space equivalent to 8½ acres.

When the addition now being built is completed, the firm will extend their line of products to embrace the manufacture of pianos, and the capacity of the works will then be the production of 600 organs and from 80 to 100 pianos per month. It is intended that the pianos, the manufacture of which is about being begun, shall be of the very best quality in all respects, and fully equal to any manufactured any where else in the world, as regards both their intrinsic merits as musical instruments, and the cases in which the actions will be enclosed, which are the features which have given the Bell organs their world-wide reputation.

The firm carry in their yards a stock of about 750,000 feet of walnut lumber, and 1,250,000 feet of other valuable woods, which ensures a supply of well-seasoned material at all times, and they will give employment to from 450 to 500 skilled artisans and workmen. Already their pay roll averages over \$150,000 a year, and many of their workmen earn from \$20 to \$25 per week. The machinery of one of these factories is driven by a Brown automatic engine, built by Mr. T. S. Worswick, late of Guelph, and of the other by an Allen & Porter engine, the aggregate capacity of the two being 160 horse power.

The business of this concern extends to almost every habitable portion of the globe. Their average shipments of organs to Europe, distributed through their agency at London, Eng., amount to seven car loads a month, and to the Australian market 18 to 20 car loads a year, besides a considerable and growing trade with South America and South Africa; and they are at this time filling an order for Japan, which will amount to two car loads of organs. The export to foreign countries business of this firm is probably larger than that of any other similar concern in either Canada or the United States. The chief cause of the favor with which the organs manufactured by Messrs. Bell & Co. is received is that the instruments are always of uniform and most excellent quality, and that buyers can always rely upon their being just as represented; another leader to success being the generous and judicious use of printers' ink.

Mr. William Bell, the senior member of the firm, and Mr. A. W. Alexander, also of the firm, have supervision of the Guelph factories and the business in this country; Mr. W. J. Bell, the junior member, having charge of the London agency. The latter gentleman is now in Australia in the interests of his house.

THE

PERMANENT EXHIBITION

Of Manufactures, and Commercial Exchange,

63, 65, 67, 69 FRONT STREET WEST (OPP. QUEEN'S HOTEL)

NICHOLLS & HOWLAND, TORONTO

DIRECTORY OF EXHIBITORS:

The following firms are already represented in the Permanent Exhibition. Their manufactures have a deservedly high reputation, and are recommended to the notice of intending purchasers of any of the respective lines in the following list. Prices, terms, discounts, etc., may be obtained from the several firms direct, or from Messrs. Nicholls & Howland, Permanent Exhibition of Manufactures:

- Armstrong, J. A. & Co., Guelph, Ont., Carpets.
 Automatic Refrigerator Co., Ottawa, Ont., Hanrahan's Patent Automatic Refrigerators.
 Barnum, The Wire and Iron Works, Windsor, Ont., Wire Goods of all descriptions, Railing, Cresting, Fencing, etc., etc.
 Barber & Ellis Co., The, Toronto, Ont., Manufacturing and Wholesale Stationers, Account Books, Office Sundries, etc.
 Bertram, John & Sons, Dundas, Ont., Iron and Wood Working Machinery.
 Blake, George F., Manufacturing Co., Boston, Mass., Steam Power Pumping Machinery.
 Beckh, Charles & Sons, Toronto, Ont., Brooms, Brushes, Woodenware, etc.
 Breithaup & Co., Berlin, Ont., Leather.
 Brush, George, Eagle Foundry, Montreal, P. Q., Blake Stone Crusher.
 Bostwick, George F., Manufacturer in Canada of Amberg's Cabinet Letter Files.
 Buines, Geo. W., Montreal, National Water Purifier.
 Batten, John, Pittsburg, Pa., Automatic Fire Escape.
 Beatty, Wm. & Sons, Welland, Ont., Centrifugal Pumps and Contractors' Machinery.
 Clare Bros. & Co., Preston, Ont., Stoves and Furnaces.
 Côte, Louis & Bros., St. Hyacinthe, P. Q., Boots and Shoes.
 Cowan & Co., Galt, Ont., Wood Working Machinery, Engines and Boilers.
 Creelman Bros., Georgetown, Ont., World's Star Knitting Machinery.
 Crompton Corset Co., Toronto and Berlin, Ont., Corsets.
 Canadian Harness Co., Toronto, Harness and Saddlery.
 Ching, J. Lionel & Co., Sydney, N.S.W., "Dugoug" Oil and Ointment, and "Dugoug" Ivory Tusks and Hide.
 Canada Screw Co., Hamilton, Ont., Wood Screws, Set Screws, Bolts, etc.
 Duperow Bros. & Co., Toronto, Varnishes, Japans, etc.
 Dalley, F. F. & Co., Hamilton, Ont., Extracts, Essences, Blacking, and Grocers' Sundries.
 Donald Produce Co., Norwich, Ont., Evaporated Fruits.
 Doty Engine Co., Toronto, Ont., Engines, Boilers, etc.
 Dominion Barb Wire Co., Montreal, P. Q. (C. A. DeLisle Western representative), Barb Wire, Plain Wires and Wire Rope.
 Dovecourt Twine Mills, Toronto, Ont., Twines and Cordage.
 Dominion Starch Works, Walkerville, Ont., Corn Starch and Laundry Starch.
 Dominion Show Case Co., Toronto, Show Cases.
 Ellis & Keighley, Toronto, Ont., Coffees, Spices.
 Elliot & Co., Toronto, Ont., Manufacturing and Wholesale Chemists and Druggists.
 Ellis, P. W. & Co., Toronto, Ont., Manufacturing and Wholesale Jewellers.
 Fenwick & Slater, Montreal, Que., Files and Mill Supplies.
 Finch, W. S. Toronto, Wood Filler and Preserver.
 Gate City Stone Filter Co., New York, Water Filters.
 Gillies, John & Co., Carleton Place, Ont., "Shipman's" Coal Oil Engines and Steam Launches.
 Globe Tobacco Co., Windsor, Ont., and Detroit, Mich., Tobaccos.
 Goodhue & Co., Danville, Que., Leather Belting and Lace Leather.
 Grand & Toy, Toronto, Ont., Tucker Automatic Letter and Document Files.
 Grand River Knitting Mills, Co., Paris, Ont., Smyrna Rugs and Knit Goods.
 Grape Sugar Refining Co., Walkerville, Ont., Syrups and Glucose.
 Gray, Wm. & Sons, Chatham, Ont., Carriages and Sleighs.
 Gillett, E. W., Toronto and Chicago, Yeast and Baking Powder.
 Gardner, W. K., Montreal (successor to H. H. Warren), Manufacturer of every description of Hammers.
 Gurney, The E. & C. Co., Hamilton and Toronto, Gravity Springless Locks, and Rotating Door Knob Furniture.
 Gurneys' & Ware & Co., Hamilton Ont., Platform and Counter Scales.
 Hudson Bros. (Limited), Sydney, N.S.W., Australian Timber and Cabinet Woods.
 Hamilton Industrial Works Co., Hamilton, Ont., Wringers, Mangles, etc.
 Hart Emery Wheel Co., Hamilton, Ont., Emery Wheels and Emery Wheel Machinery.
 Hay, Peter, Galt, Ont., Machine Knives.
 Hearle, J. G., Montreal, Que., Toilet Soaps and Perfumery.
 Howland, H. S. & Sons & Co., Toronto, Ont., Hardware Specialties.
 Howland, H. S., Kleinbourg, Ont., Flour.
 Hemming Bros., Toronto, Ont., Fancy Plush Goods and Jewellers' Cases.
 Herman, J. W., Toronto, Boiler Water Purifier.
 Hamilton Whip Co., Hamilton, Ont., Whips.
 Ives, H. R. & Co., Montreal, P. Q., Fencing, Cresting, Stoves and Hardware Novelties.
 Jardine, A. & Co., Toronto, Ont., Coffee, Spices, and Pure Gold Baking Powder.
 Jenkins & Co., Toronto, Ont., Baking of all kinds.
 Keer, Waj. Gen'l, Toronto, Ont., Himalayan Teas.
 Kerr Bros., Walkerville, Ont., Water, Steam and Gas Valves of Improved Pattern.
 King, R. W. & Co., Georgetown, Ont., Power Knitting Machinery.
 Leslie, James, Montreal, Que., Woollen and Cotton Mill supplies.
 McCaskill, D. A. & Co., Montreal, Que., Varnishes and Japans.
 Miller Bros. & Mitchell, Montreal, Que., Beaudry's Steam Power Hammer.
 Munderloh & Co., Montreal, Que., Watchmen's Clocks.
 Morris, A. W. & Bro., Montreal, Que., Cordage and Binder Twine.
 Morrison James, Toronto, Steamfitters' and Plumbers' Supplies.
 McLaren, The J. C. Belting Co., Montreal, Mill Supplies.
 Montgomery, L. B., Toronto, Mill Supplies.
 North, Wm. & Sons, Leeds, England, Teazels.
 Northey & Co., Toronto, Ont., Steam Pumping Machinery.
 Northumberland Paper Co., Campbellford, Ont., Straw Board and Tanned Paper.
 Ontario Bolt Co., Toronto, Ont., Bolts, Nuts, Spikes, etc.
 Oshawa, Stove Co., Oshawa, Ont., Cooking and Heating Stoves.
 Pepper, T. & Co., Guelph, Ont., Carriage and Wagon Axles.
 Perrich, M., Parkdale, Ont., East Indian Specialties.
 Pillow, Hersey & Co., Montreal, Que. (Geo. A. MacAgy, Western representative), Nails, Tacks, Bolts, etc.
 Poliwka Emil, Montreal, Que., Sapolio and Bronzes.
 Pugh, Frank, Toronto, Ont., Brass Goods.
 Ramsay & Son, Montreal, Que., Plate and Stained Glass, Paints, Oils, etc.
 Robin & Sadler, Montreal, Que., and Toronto, Ont., Leather Belting and Leather.
 Shurly & Dietrich, Galt, Ont., Saws of every description.
 Simpson & Co., Berlin, Ont., Furniture.
 Smith, R. H. & Co., St. Catharines, Ont., every description of Saws.
 Stahlschmidt & Co., Preston, Ont., Office Desks, Chairs, School Furniture, etc.
 Slight, H., Toronto, Florist.
 St. Thomas Featherbone Co., St. Thomas, Ont., Featherbone Corsets, Whips, etc.
 Strickland, George A., Lakefield, Ont., Patent Cutter.
 Taylor, John J., Toronto, Fire and Burglar Proof Safes, Vaults, etc.
 Tees & Co., Montreal, Que., Revolving Book Cases, Wood, Carpets, etc.
 Teller, Rothwell & Co., Montreal, Stove Polish, etc.
 Toronto Lead & Color Co., Toronto, Ont., Prepared Paints, White Lead, etc.
 Toronto Rubber Co., Toronto, Belting, Fire Hose, Etc.
 Toronto Novelty Manufacturing Co., Toronto, Ont., Ironing Boards.
 Watts, A. & Co., Brantford, Ont., Household Soaps.
 Warren, H. R., representing The Meriden Britannia Co., Hamilton.

IN CONNECTION WITH OUR PERMANENT EXHIBITION WE HAVE EXCELLENT

STORAGE—LIGHT, DRY, CLEAN.

Our facilities for receiving and shipping are unsurpassed, and we invite inspection or correspondence.

SEND FOR ILLUSTRATED CIRCULAR.

BELDING, PAUL & CO. SILK MANUFACTURERS MONTREAL.

ORGANZINES, TRAMS,
SPUN SILK YARNS,

And all Threads for Manufacturing Pur-
poses made to order.

Correspondence Solicited.

THE WELLINGTON MILLS LONDON

GENUINE EMERY

OAKEY'S Flexible Twilled Emery Cloth.
OAKEY'S Flint Paper and Glass Paper.
OAKEY'S Emery Paper, Black Lead, &c., &c.

PRIZE MEDAL AND HIGHEST AWARD, PHILADELPHIA, 1876.
For Superiority of Quality, Skilful Manufacture, Sharpness,
Durability, and Uniformity of Grain.

Manufacturers: JOHN OAKEY & SONS, Wellington Mills,
WESTMINSTER BRIDGE ROAD, LONDON, ENGLAND.

Enquiries should be addressed to

JOHN FORMAN, 467, ST. PAUL ST., MONTREAL.

CANTLIE, EWAN & CO.

General Merchants and Manufacturers' Agents.

BLEACHED SHIRTINGS,
GREY SHEETINGS, TICKINGS,
WHITE, GREY AND COLORED BLANKETS,
FINE AND MEDIUM TWEEDS, KNITTED GOODS,
PLAIN AND FANCY FLANNEL,
LOW TWFEDS, ETOFFES, ETC.

Wholesale Trade Only Supplied.

15 VICTORIA SQUARE,
MONTREAL.

20 WELLINGTON ST. E.
TORONTO.

PATENT BOILER WATER PURIFIER.

NO PURGER
USED.
HEAT ALONE
DOES IT.

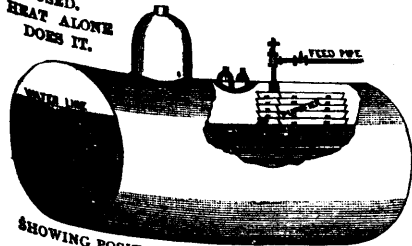

SHOWING POSITION OF PURIFIER IN BOILER.

THIS PURIFIER ENTIRELY PREVENTS THE FORMATION OF SCALE UPON SHELL AND FLUES OF ANY BOILER IN WHICH IT IS USED. ALL IMPURITIES ARE EXTRACTED FROM THE WATER BEFORE IT REACHES THE WATER LINE, AND ARE DEPOSITED IN THE PANS OF THE PURIFIER.

THESE PANS CAN BE REMOVED, CLEANED AND REPLACED WITH VERY LITTLE TROUBLE, AND IN A VERY SHORT TIME, WITHOUT EMPTYING THE BOILER OF HOT WATER, WHICH MEANS A SAVING OF TIME, LABOR AND FUEL.

FOR PARTICULARS AND PRICES ADDRESS

J. W. HERMAN, 114 1/2 King St. West, Toronto, Ont.

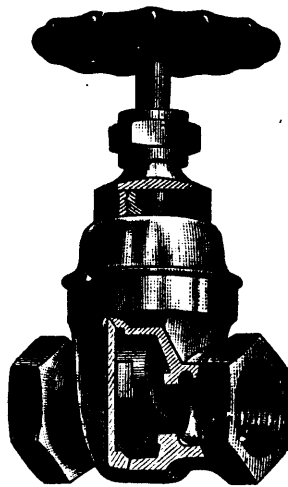

WEBER'S PATENT Straightway Valves

FOR
STEAM, WATER AND GAS,
BEST VALUE IN THE MARKET.

KERR BROS.
Walkerville, Ont.

Sole right to manufacture in the Dominion.
Send for Price Lists.

Also manufacturers of COMPOUND MARINE
AND STATIONARY ENGINES.

Crown Water Closet.
Inodoro Water Closet.
Perfect Water Closet.
Jenning's Valve Closet.
Demarest Valve Closet.
Alexander Valve Closet.
A full stock of Washbasins,
Urinals, etc.
Also, complete stock of Wrought
Iron Pipe and Fittings.
Brass and Iron Valves.
Plumbers' and Steamfitters
Brass Work.
Rubber Hose, Belting, Pack-
ing, etc.
Sole Canadian representative of
the Celebrated Hancock In-
spirator.

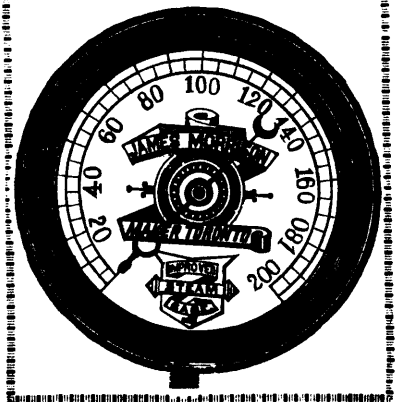

JAMES MORRISON,

IMPORTER AND MANUFACTURER
OF

Steamfitters' and
Plumbers' Supplies

75 & 77 ADELAIDE ST. WEST,
TORONTO.

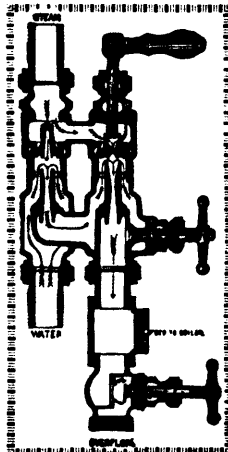

SANITARY EARTHENWARE Now in Stock: Morrison's Washout Hopper
National Water Closet.

The Canadian Manufacturer

REACHES NEARLY EVERY INDUSTRIAL
AND MANUFACTURING ESTABLISHMENT IN CANADA: AND IS
THE BEST ADVERTISING
MEDIUM OF COMMUNICATION BETWEEN THE BUYER AND THE SELLER

Subscription Price \$2 a year.
Advertising Rates Sent on Application.

THE CANADIAN MANUFACTURER PUBLISHING CO., TORONTO.

Dodge Patent Wood Separable or Split Pulleys.

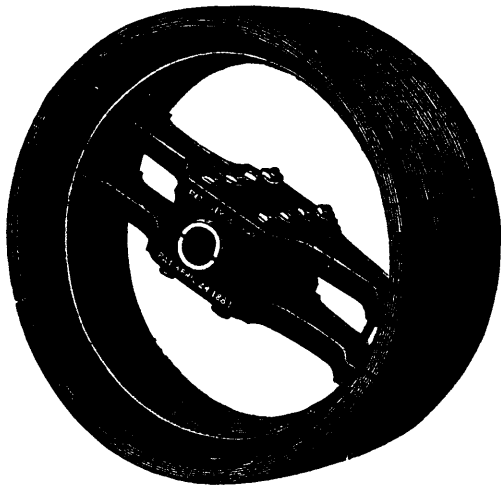

Best Belt Surface, Lightest, Strongest, Best Balanced and Most Convenient Pulley in the World.

With our Patent Bushing System

Every pulley will fit 22 different sizes of shafting, and guaranteed to give from 30 to 60 per cent. more power from same belt and like tension than any iron or steel pulley. Every pulley a split pulley, 70 per cent. lighter than cast iron, and 50 per cent. lighter than wrought iron or steel. Strong enough for any power required. Made in any size from nine inches to sixteen feet diameter.

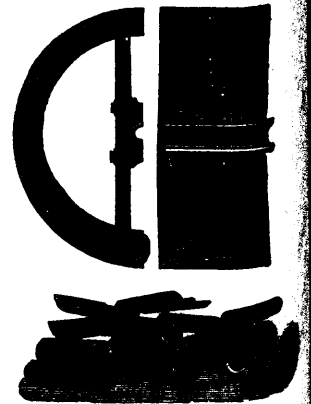

THE TRANSMISSION OF POWER BY ROPES AND THE DODGE PATENT WOOD PULLEYS.

The great advantage of Wood over Iron as a material for belt pulleys (or drums) to transmit power economically, has induced the DODGE WOOD SPLIT PULLEY CO., of Toronto, to introduce grooved hardwood pulleys for the special purpose of transmitting power by ropes (manilla tallow laid), and in this connection Mr. Dodge has taken out Canadian Letters Patent for a system of applying the ropes, adjusting the pulleys, and taking up slack, that is giving the most unqualified satisfaction.

This system of transmitting power by ropes is cheaper and superior to belts in many cases, such as where the driven shaft is at right angles with the driver, also where the drive is perpendicular, particularly when it is quarter twist and perpendicular; also where the driver and driven are

close together; also for long drives, such as across a street, or a stream, etc. For transmitting power from an engine to the line shaft this system is unequalled; steady all the time, not like a heavy belt, which is always more or less flapping, jerking and stretching, then slipping and losing power. It is safe to say that an engine hitched up by the Dodge Rope System will do 25 per cent. more work on the same consumption of fuel than the same engine would do with a belt. We have put up a number of the Dodge Patent Rope transmissions during the past year, all of which are in most successful and satisfactory operation, as certified by the testimonials published in our catalogue of well-known manufacturers who have them in use.

WITH OUR SYSTEM OF MANILLA ROPE TRANSMISSION is overcome the objection to Wire Rope (because of crystallizing) and gearing, (because of loss of friction) and shafting (because of the liability to get out of alignment, hence loss of power by friction), and a separate engine plant (because of its great expense); on the contrary, with the Manilla Rope System, under the Dodge patents, the power is transmitted with the same efficiency as though the shafts were close together, there being no loss of power by excessive tension, or bad alignment, but simply the friction of the journals to overcome at the carriers, which have a strain of weight of the rope to carry.

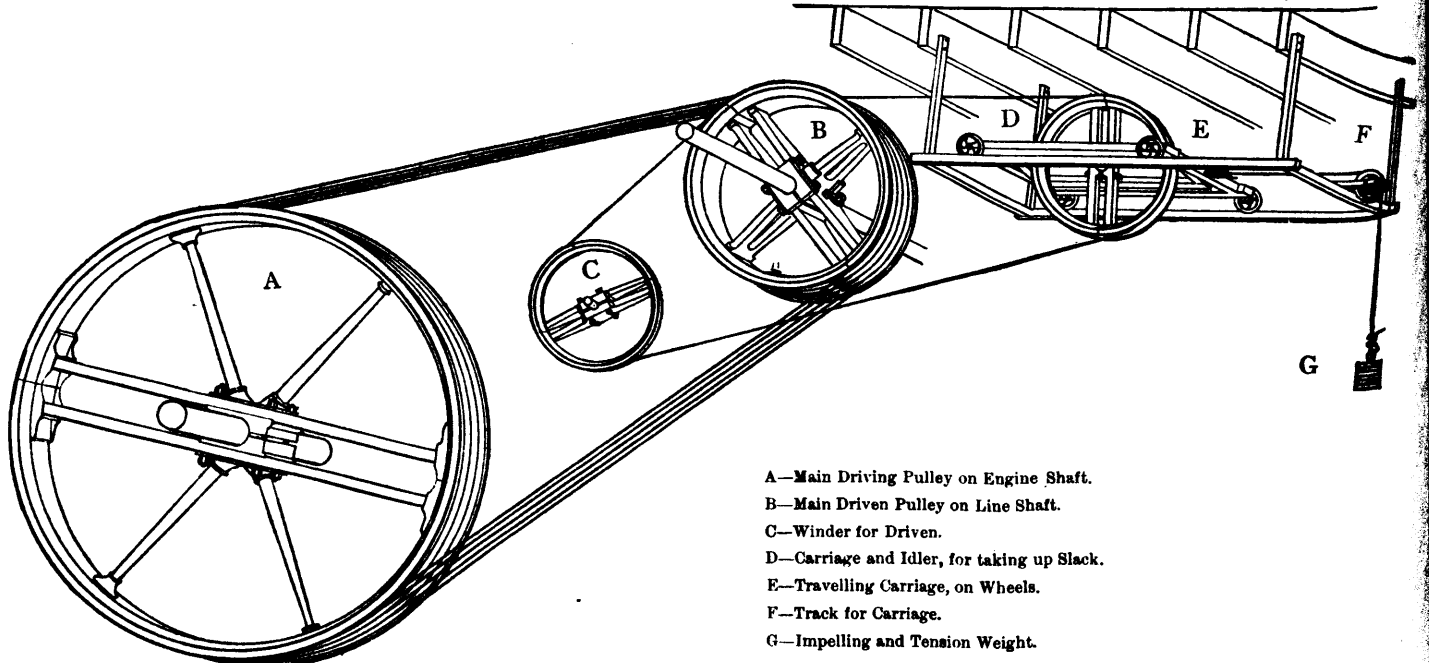

A—Main Driving Pulley on Engine Shaft.
 B—Main Driven Pulley on Line Shaft.
 C—Winder for Driven.
 D—Carriage and Idler, for taking up Slack.
 E—Travelling Carriage, on Wheels.
 F—Track for Carriage.
 G—Impelling and Tension Weight.

The illustration, as shown above, is one of peculiar construction, and represents an engine transmitting its power to the line shafting by the Dodge Patent System of manilla ropes and grooved hardwood pulleys. Transmissions similar to the above are now in use at the works of the following well-known manufacturers in Toronto:—

A. R. Clark & Co., Leather and Glove Manufacturers, 50 H.P.; T. Tushingham & Son, Builders, 35 H.P.; J. R. Black, Carriage Works, 50 H.P.; Barber & Ellis Co., Stationers, 8 drives, 87 H.P.; Jas. Lochrie, Rope Manufacturer, 60 H.P.; J. P. Wagner & Co., Show Case and Keyboard Manufacturers, 50 H.P.; J. Taylor, Morse Soap Works, 60 H.P.; Joseph Simpson, Knitting Mills, 80 H.P.; and numerous others whose testimonials can be seen in our catalogue. Parties who are in want of anything in this line, or who are interested in the efficient and economical transmission of power, are cordially invited to call at our works and see the ropes and wood pulleys in operation, as we are driving our whole factory by this system. Send for Price List, Catalogue and Cypher Code, for ordering by telegraph, to

THE DODGE WOOD SPLIT PULLEY CO., 89 ADELAIDE ST. W., TORONTO.

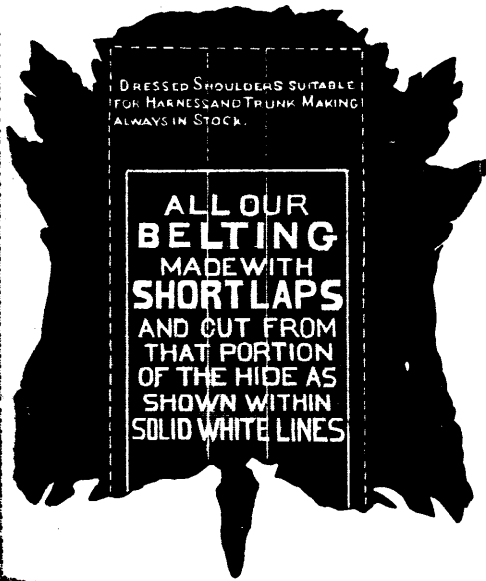

ROBIN & SADLER,
 MANUFACTURERS OF
Leather Belting

SEND FOR PRICE LISTS AND DISCOUNTS.

MONTREAL, 2518, 2520, 2522, Notre Dame St.

TORONTO, 129 Bay St.

TELEPHONE 110 B.

TELEPHONE 1101.

Mill Owners in the West will find it to their advantage to order their BELTING from our Toronto House.

We guarantee their orders well and promptly filled, for we keep on hand all sizes from 2 to 16 inch, SINGLE AND DOUBLE; also: Lace Leather, Belt Hooks, Belt Punches, etc., etc.

Nova Scotia Steel Co., Limited,

NEW GLASGOW, NOVA SCOTIA,

(Only Steel Works in Canada),

MANUFACTURERS OF

Hammered and Rolled Steel

MADE BY THE

SIEMENS-MARTIN (OPEN HEARTH) PROCESS.

ROUND MACHINERY STEEL for Shafting, Spindles, etc. MILD STEEL for Rivets, Bolts Thresher Teeth, and many purposes where Norway Iron is now used.

SPECIAL SECTION PLOW BEAMS, MILD STEEL CENTRE AND SOLID MOULD BOARDS, COULTER STEEL HARROW DISCS,

AGRICULTURAL STEEL CUT TO PATTERN, SPRING, SLEIGH SHOE, TYRE, TOE CALK AND CROSS BAR STEEL STEEL NAIL PLATE.

□ Binder Bars, Z and other Special Sections.

STEEL MOWER BARS.

Particular attention given to the manufacture of Rake, Cultivator and Harrow Teeth, and other Agricultural Spring Steel Forgings.

New Brunswick Cotton Mills

Saint John Cotton Mills,

WM. PARKS & SON, Ltd.

SAINT JOHN, N.B.

**Cotton Spinners, Bleachers, Dyers and
Manufacturers.**

- Cotton Yarns, Nos. 5 to 10, White & Colored.
- Cotton Carpet Warp, White & Colored.
- Ball Knitting Cotton, in all numbers and colors.
- Cotton Hosiery Yarn, suitable for manufacturers of Hosiery.
- Grey Cottons, in a variety of grades.
- Fancy Weave Shirtings, in several grades and new patterns.
- Seersuckers, in Stripes and Fancy Checks.
- Cottonades, in Plain, Mixed and Fancy Patterns.

AGENTS,

**DUNCAN BELL, Montreal and Quebec.
WM. HEWETT, Toronto.**

Dick, Ridout & Co.

MANUFACTURERS' AGENTS

TO THE

WHOLESALE TRADE ONLY.

STORAGE ACCOMMODATION. ADVANCES MADE.

HEAD OFFICE :

**11 & 13 FRONT ST. EAST,
TORONTO.**

Branches : Montreal and Winnipeg. Correspondence Solicited. References Given.

FIRE PROTECTION

BUILDINGS EQUIPPED

WITH

**AUTOMATIC
SPRINKLERS**

BY

ROBERT MITCHELL & CO.

MONTREAL BRASS WORKS.

Write for estimates.

MONTREAL.

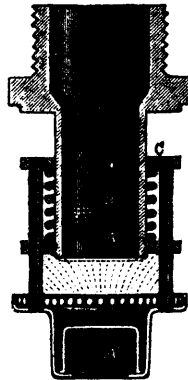

SHURLY & DIETRICH, Galt, Ont.

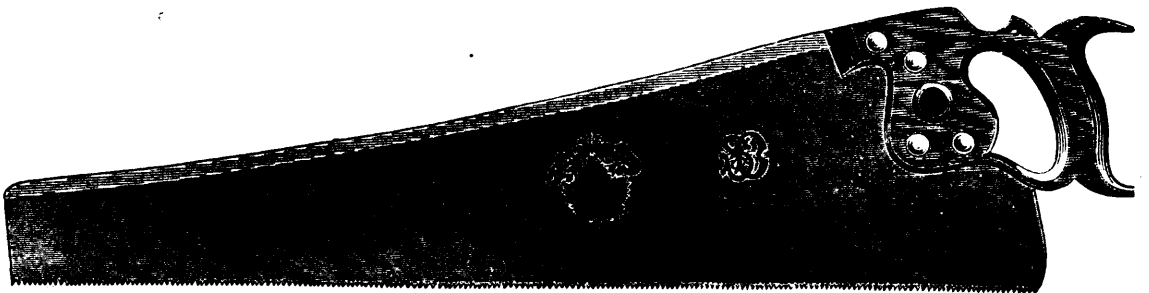
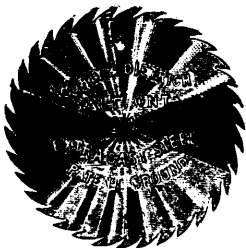

MANUFACTURERS OF SAWS OF ALL KINDS.
LARGEST SAW MANUFACTURERS IN CANADA.

So e Proprietors of the Secret Chemical Process of Tempering.
Our Silver Steel Saws are unequalled.



**SIMPLE,
PRACTICAL,
LOW PRICED.**

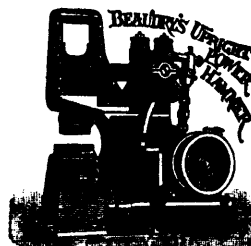

**ENTIRELY
NEW
DESIGN.**



BEAUDRY UPRIGHT CUSHIONED POWER HAMMER.

Does not vibrate.
Requires no helper.
Always ready for use.
Does not chill the work.

Gives a perfectly square blow.
Has open space between the dies.
The stroke can be changed easily
and quickly.

Will give one blow or more as re-
quired, light or heavy.
Can be run cheaply and with very
little power.

The anvil is entirely separate from
the frame.
It is the least complicated and
most efficient power hammer in
the world.

This Hammer may be seen at Permanent Exhibition, Toronto, Ont.

SEND FOR PRICE LIST.

MILLER BROS. & MITCHELL, Sole Makers for Canada, MONTREAL.

AUSTRALIA-IMPORTANT TO MANUFACTURERS.

Established 1878.

ALBERT S. MANDERS & CO.,

THE AUSTRALIAN COMMISSION HOUSE.

Head Office, 30 Collins Street, MELBOURNE, also at King Street, SYDNEY, and King William Street, ADELAIDE.

Agency Wanted for First-Class Goods. Samples should be sent with Lowest Prices to our Head Office.

NOTE.—We are the Only Firm that have a Branch House in the three Leading Colonies.

LONDON, 11 Mansion House, Chambers, 10 Queen Victoria St., E.C. NEW YORK, Mayo & Watson, Australasian Office, 22 & 23 State St. CANADA, Nicholls & Howland, 63 Front St. West, Toronto.

The Doty Vertical Engine and Boiler.

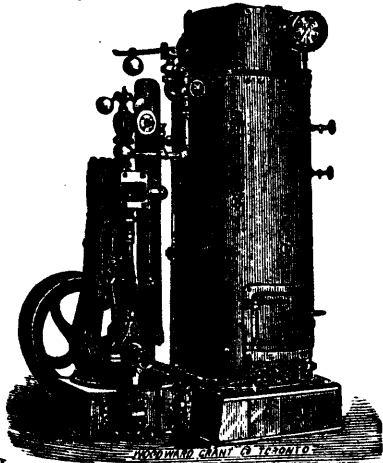

SEND FOR REDUCED PRICE LIST.

JOHN DOTY ENGINE CO.

No. 2 Bathurst Street.

TORONTO, ONT.

In sizes from 3 to 10 H.P. Specially adapted to places where 3 to 10 H.P. is required. Simple, safe and durable

THE

Otto Silent Gas Engine.

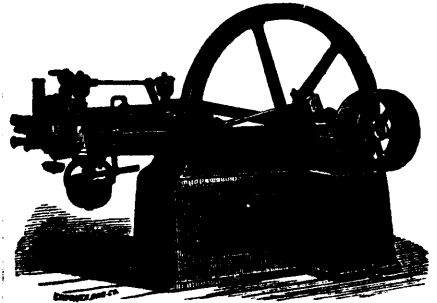

In sizes from 2 to 7 H.P. Most convenient power in the market.

SEND FOR CIRCULAR.

THE INTERCOLONIAL

RAILWAY OF CANADA.

The Royal Mail Passenger and Freight Route between Canada and Great Britain,

AND Direct Route between the West and all points on the Lower St. Lawrence and Bale de Chaleur, also New Brunswick, Nova Scotia, Prince Edward's Island, Cape Breton, Newfoundland, Bermuda and Jamaica.

New and elegant Buffet Sleeping and Day Cars run on Through Express Trains.

Passengers for Great Britain or the Continent by leaving Toronto per 8.30 a.m. train Thursday, will join outward Mail Steamer at Halifax a.m. Saturday.

Superior Elevator, Warehouse and Dock accommodation at Halifax for shipment of grain and general merchandise.

Years of experience have proved the Intercolonial, in connection with Steamship lines to and from London, Liverpool and Glasgow to Halifax, to be the quickest Freight route between Canada and Great Britain.

Information as to Passenger and Freight Rates can be had on application to

ROBERT B. MOODIE,

Western Freight and Passenger Agent, 93 Ross House Block, York Street, TORONTO.

D. POTTINGER,

Chief Superintendent.

Railway Office, Moncton, N.B., Nov. 22nd, 1886.

JAMES LESLIE

MANUFACTURER OF

MACHINE CARD CLOTHING AND LOOM REEDS.

LEATHER BELTING LACE LEATHER & ROSE

COTTON AND WOLLEN MILL SUPPLIES



COTTON LOOM HARNESS AND WIRE HEDDLES

OFFICE AND FACTORY

JUNCTION OF CRAIG AND ST. ANTOINE STREETS.

MONTREAL.

The Canadian Manufacturer

IS THE OLDEST TRADE JOURNAL PUBLISHED IN CANADA,

And is the only paper in the Dominion published entirely in the

INTERESTS OF CANADIAN MANUFACTURERS.

All the various manufacturing industries of Canada are represented in its columns, and it is and always has been the fearless and consistent advocate of those reforms indispensable to the success of home manufacturing industries.

AS REGARDS THE INTERESTS TO WHICH IT IS DEVOTED, IT IS THE

Best Advertising Medium in Canada.

ITS ADVERTISING RATES ARE REASONABLE.

Specimen Copies, with Rate Card, will be sent Free, on application.

Send \$2 and receive it twice a month, postage paid, for one year.

ADDRESS,

CANADIAN MANUFACTURER,

6 WELLINGTON STREET WEST.

TORONTO, ONTARIO, CANADA.

THOMPSON & CO.,

SHERBROOKE, QUE.,

MANUFACTURERS OF

BOBBINS AND SPOOLS

OF EVERY DESCRIPTION,

For Woolen, Cotton and Rope Mills.

Extra facilities for supplying new mills and filling large orders.

CORRESPONDENCE SOLICITED.

ORDERS PROMPTLY FILLED.

SUPERINTENDENTS COTTON, WOOL AND WORSTED MILLS.

The Third edition of "THE RED BOOK" is ready. Get a copy of it and save money in buying your supplies. It places you in *direct* communication with *first hands*, thereby securing the advantages to be gained by *competitive prices*. Anything from a Ring Traveler to a Loom, Acetic Acid to Zinc Dust, Yarns of all kinds, Shoddy, Flocks, Cotton Buyers, Wool, New Devices, and Steam Appliances—in fact, everything needed for Cotton, Woolen and Worsted Mills, classified and indexed, compact and reliable. It also contains Yarn Tables, Cotton and Wool Products, and amounts used each year from 1841 to date by Northern and Southern Mills, Exports, Statistics, Receipts and information of considerable value to mill men. Sent post-paid on receipt of price in cash or stamps (U.S. or Canadian).

ONE DOLLAR, Cloth. FIFTY CENTS, Paper.

ADDRESS—

J. E. PALMER, Publisher,

176 BROADWAY, NEW YORK.

THOMAS C. KELLOGG, SKANEATELES N.Y., U.S.A.,

Teasels are grown, cured and packed on own premises.
New York Office,
100 & 102 Beade Street
A. H. KELLOGG, Manager.

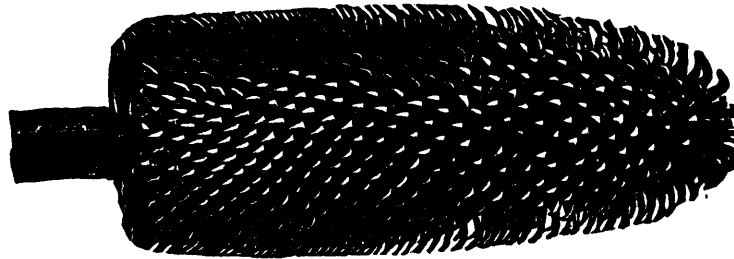

DESIRED SIZE.
TO ANY
CLIPPED AND PACKED
AMERICAN TEASELS.
AND
CROWER OF
TREATERS 127

T. H. EATON & SON, Windsor, Ont., and Detroit, Mich., Agents for Ontario.

Correspondence Solicited.

WRITE FOR PRICE LIST NO. 71.

Samples sent by Mail upon Application.

THE CHATHAM MANUFACTURING CO. (Ltd.)

MANUFACTURERS OF

HARDWOOD LUMBER,

SHIP PLANK AND



THE CHATHAM WAGON, Of which wagon the above is a faithful cut, and which the Government of the Dominion of Canada has adopted as the STANDARD WAGON

We simply ask intending purchasers, in their own interests, to send to us for particulars of the Chatham Wagon, or if there is one convenient closely examine it before purchasing any other.

We also make Railway Platform Baggage Trucks, Farm and other Dump Carts, the Celebrated Main Bob Sleigh, the Patent Champion Hay Rack, etc., etc.

CORRESPONDENCE SOLICITED.

CHATHAM MANUFACTURING CO. (LIMITED).

**THE BELL
Telephone Co'y**

OF CANADA.

—Manufacturers and Dealers in—

Telegraph & Electrical

INSTRUMENTS,

Electro-Medical Apparatus,

Fire Alarm Apparatus,

Magnets for Mills

Electrical Gas Lighting Apparatus,

Burglar Alarms,

Hotel and House Annunciators,

Electric Call Bells, &c., &c.

For further particulars apply to

No. 12 HOSPITAL STREET,

MONTREAL.

Dominion Showcase Works,

WAGNER, ZEIDLER & CO.

(Formerly **DOMINION SHOWCASE CO.**)

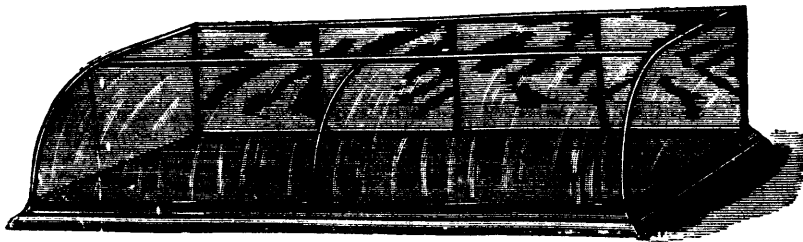

Showcases, Store-Fittings, Tables, Office Cabinets, Desks, Mantels, &c.

HIGHEST AWARDS WHEREVER EXHIBITED.

Factory and Head Office :

WEST TORONTO JUNCTION.

Toronto Office and Show Rooms :

40 YONGE STREET.

Send for Catalogue and Price List, and address all communications to Head Office.

Canada Tool Works,

JOHN BERTRAM & SONS

DUNDAS, ONT

MANUFACTURERS OF

MACHINE TOOLS AND WOOD-WORKING

MACHINERY.

IN OUR LIST WILL BE FOUND THE FOLLOWING :

Lathes, Planers, Drills, Bolt Cutters, Punches and Shears, Boiler Rolls, Slotting, Milling and Cutting off Machines, Shafting Lathes, Pulley Turning and Boring Machines, Wood Planing and Matching Machines, Moulding, Mortising and Tenoning Machines, Band and Scroll Saws, Wood Turning Lathes, etc.

Complete Sets of Machinery for Locomotive and Car Works, Implement Works, Cabinet Factories, etc.

Write for prices of our New Acme Bolt Cutters, the best machine made.

Price Lists and Catalogues mailed on application.

Business established 1862.

KNOWLES STEAM PUMP WORKS,
 —BUILDERS OF—
STEAM PUMPING MACHINERY IN EVERY VARIETY

**BOILER
 FEED,
 FIRE
 and
 TANK
 PUMPS**

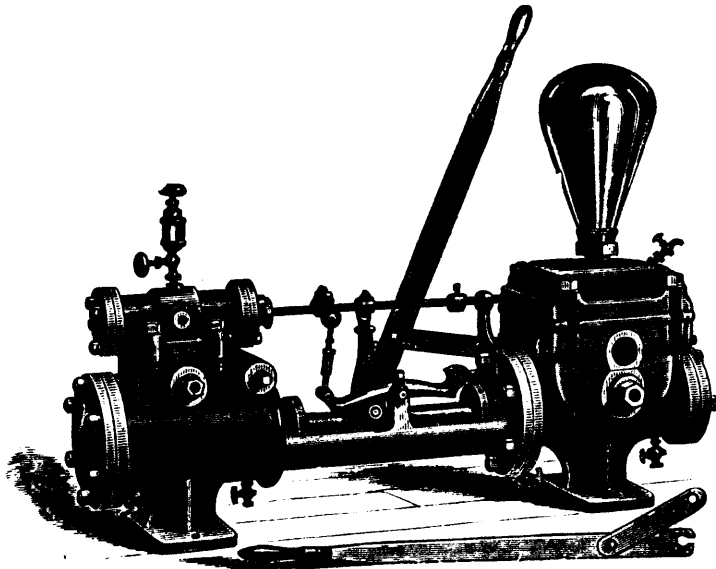

Simple and Duplex
**PUMPING
 ENGINE**
 for
TOWN and CITY
SUPPLY.

For Particulars,
 Address

113 Federal St., BOSTON.

93 Liberty St., NEW YORK.

—SEND FOR ILLUSTRATED CATALOGUE.—

Geo. F. Blake Manufacturing Co., ✧

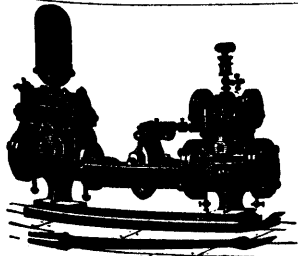

BOILER FEED PUMP.

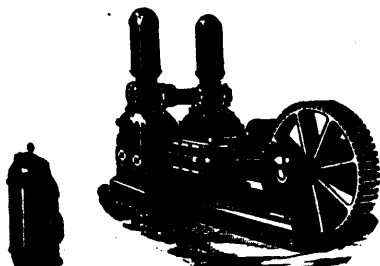

GEARED FEED PUMP.

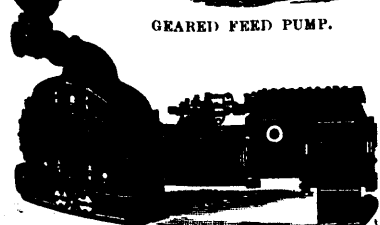

DUPLEX COMPOUND ENGINE.

BUILDERS OF
 SINGLE AND DUPLEX
 Steam and Power
Pumping Machinery



BOSTON,
 111 FEDERAL STREET. ✧

✧ **NEW YORK,**
 95 & 97 LIBERTY STREET.

SEND FOR ILLUSTRATED CATALOGUE.

These goods may be seen at the Permanent
 Exhibition, 63 to 69 Front Street West, Toronto.

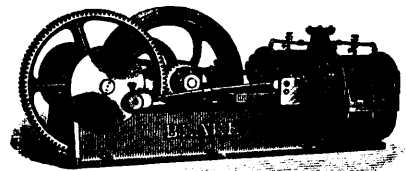

AIR COMPRESSOR.

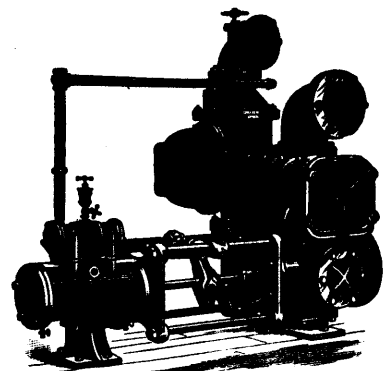

AIR PUMP AND CONDENSOR.

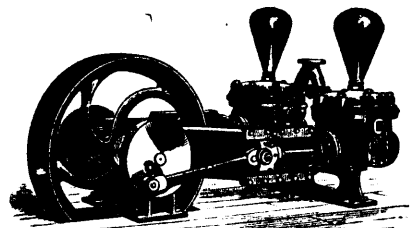

BELT PUMP

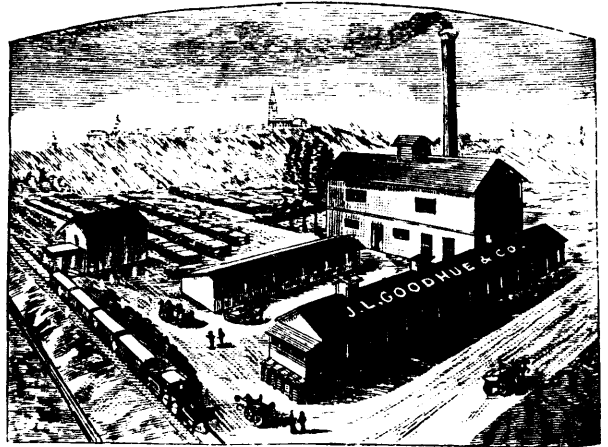
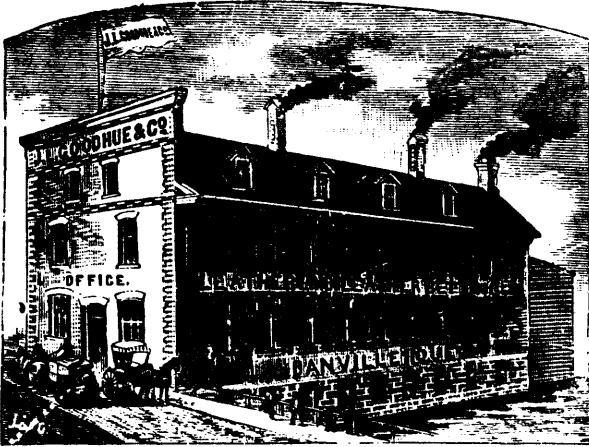

J. L. GOODHUE & CO.

ORDERS PROMPTLY FILLED. **LEATHER BELTING** WRITE FOR PRICES.

✽ DANVILLE, P. QUE. ✽

GALT MACHINE KNIFE WORKS.

PLANING MACHINE KNIVES. 

STAVE CUTTER KNIVES.



STAVE JOINTER KNIVES.



MOULDING, TENONING,
MITREING,
SHINGLE JOINTER,
And other irregular shapes.

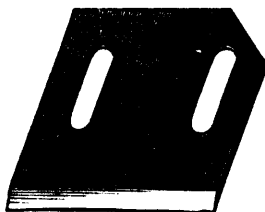

Cheese-box and Veneer, Paper Cutting, Leather Splitting and any special knife made to order. SEND FOR PRICE LIST. ALL WORK WARRANTED.
PETER HAY, - - - **GALT ONT.**

Millers' and Manufacturers' INSURANCE COMPANY.

STOCK AND MUTUAL OBJECTS.

1. To prevent by all possible means the occurrence of avoidable fires.
2. To obviate heavy losses from the fires that are unavoidable by the nature of the work done in mills and factories.
3. To reduce the cost of insurance to the lowest point consistent with the safe conduct of the business.

METHODS.

All risks will be inspected by a competent officer of the company, who will make such suggestions as to improvements required for safety against fires, as may be for the mutual interests of all concerned.

Much dependence will be placed upon the obligation of members to keep up such a system of discipline, order, and cleanliness in the premises insured as will conduce to safety.

As no agents are employed and the company deals only with the principals of the establishments insured by it, conditions and exceptions which are so apt to mislead the insured and promote controversy and litigation in the settlement of losses will thus be avoided.

The most perfect method of insurance must, in the nature of things, be one in which the self-interest of the insured and the underwriters are identical, and this has been the object aimed at by the organizers of this company.

W. H. HOWLAND, Vice-President. **JAMES GOLDIE,** President.
HUGH SCOTT, Managing Director.

Applicants for Insurance and other information desired, please address **MILLERS' AND MANUFACTURERS' INSURANCE COMPANY** No. 24 Church Street, Toronto.

MACHINE BRUSHES

All kinds, Made to Order.

Highest Quality of Work Guaranteed.

Send full particulars of Dimensions and Quality when ordering.

OLD ROLLERS OR BLOCKS RE-FILLED WITH SPECIAL CARE.

CHAS. BOECKH & SONS,

MANUFACTURERS.

Office and Warerooms:

Factory:

80 YORK STREET. | 142 to 150 Adelaide St. West.
TORONTO, CANADA.



NOTICE.

A NUMBER of School Sections in the Province of Manitoba will be offered for sale at public auction at the following places, on the undermentioned dates, viz:—
At *Manitow* on the 10th January, 1888; at *Winnipeg* on the 17th January, 1888; at *Portage la Prairie* on the 24th January, 1888; at *Brandon* on the 31st January, 1888; at *Minnedosa* on the 7th February, 1888.

In any case in which a settler on any quarter section of land included in the list referred to can prove to the satisfaction of the Commissioner of Dominion Lands that he was *bona fide* residing upon and cultivating the said quarter section, in ignorance of the law, on the 1st day of October, 1887, the purchaser of the quarter section, if he be other than the said settler, will be required to pay, for the benefit of the said settler, the value of the improvements thereon.

Lists of the lands to be sold, the upset price of each parcel, the terms of sale, and any other information which intending purchasers may desire to obtain may be had on application to the Secretary of the Department of the Interior, Ottawa; to the Commissioner of Dominion Lands, Winnipeg; or to any Agent of Dominion Lands in Manitoba or the North-West Territories.

A. M. BURGESS,
Deputy of the Minister of the Interior.

No unauthorized insertion of this advertisement will be paid for.

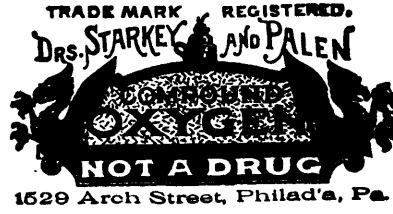

A Well Tried Treatment

FOR

Consumption, Asthma, Bronchitis, Dyspepsia, Catarrh, Hay Fever, Headache, Debility, Rheumatism, Neuralgia and all Chronic and Nervous Disorders.

"The Compound Oxygen Treatment," Drs. Starkey & Palen, No. 1529 Arch Street, Philadelphia, have been using for the last seventeen years, is a scientific adjustment of the elements of Oxygen and Nitrogen magnetized, and the compound is so condensed and made portable that it is sent all over the world.

DRS. STARKEY & PALEN have the liberty to refer to the following named well-known persons who have tried their Treatment:

Hon. Wm. D. Kelley, Member of Congress, Philadelphia; Rev. Victor L. Conrad, Editor "Lutheran Observer," Philadelphia; Rev. Charles W. Cushing, D.D., Rochester, N.Y.; Hon. Wm. Penn Nixon, Editor "Inter-Ocean," Chicago, Ill.; Rev. A. W. Moore, Editor "The Centenary," Lancaster, S.C.; W. H. Worthington, Editor "New South," Birmingham, Ala.; Judge H. P. Vrooman, Quenemo, Kan.; Mrs. Mary A. Livermore, Melrose, Mass.; Judge R. S. Voorhees, New York City; Mr. F. C. Knight, Philadelphia; Mr. Frank Siddall, Merchant, Philadelphia; Hon. W. W. Schuyler, Easton, Pa.; Edward L. Wilson, 333 Broadway, N.Y., Editor Philadelphia "Photographer"; Fidelity M. Lyon, Waimea, Hawaii, Sandwich Islands; Alexander Ritchie, Inverness, Scotland; Mrs. Manuel V. Ortega, Fresnillo, Zacatecas, Mexico; Mrs. Emma Cooper, Uvilla, Spanish Honduras, Central America; J. C. bb, U.S. Vice-Consul, Casablanca, Morocco; M. V. Ashbrook, Red Bluff, Cal.; Ernest Turner, Nottingham, England; Jacob Ward, Bowral, New South Wales, and thousands of others in every part of the world.

"Compound Oxygen—its Mode of Action and Results," is the title of a new brochure of two hundred pages, published by Drs. Starkey & Palen No. 1529 Arch St., Philadelphia, Pa., which gives to all inquirers full information as to this remarkable curative agent, and a record of several hundred surprising cures in a wide range of chronic cases—many of them after being abandoned to die by other physicians. Will be mailed free to any address on application by addressing

E. W. D. KING,

58 Church St., Toronto, Ont.

BELL ORGANS

FOR
Chapel,
Church,
Lodge,
Parlor.

ARE THE BEST

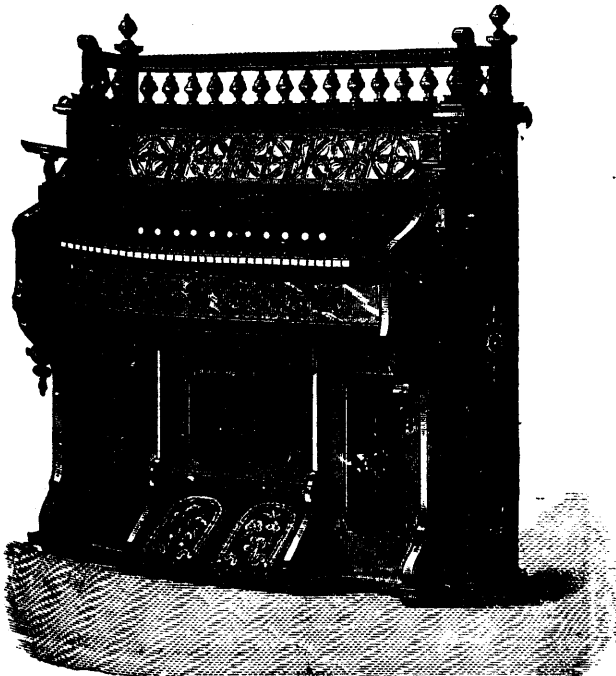

OUR Large Double and Single Manual Organs are the best in the Market, and Musicians should see them before buying elsewhere.

CATALOGUES
SENT ON APPLICATION

W. BELL & CO.,

GUELPH, CANADA.

Industrial and Trade DIRECTORY.

Acids and Aniline Dyes.

THEO. H. EATON & SON, Windsor, Ont.; Detroit, U.S.A.—Importers. Every Description **Pure Aniline Dyes** for Cotton and Woollen Manufacturers. **Dyed Samples** furnished on application. Address all correspondence to Head Office, Detroit, Mich.

Agricultural Implements.

A. S. WHITING MANUFACTURING CO., Cedar Dale, Ont.—Manufacturers of scythes, forks, hoes, etc.

WELLAND VALE MANUFACTURING CO.—Lock No. 2, St. Catharines, Ont., Canada—Manufacturers of axes, scythes, forks, hoes, rakes and edge tools.

Bobbins and Spools

THOMPSON & CO., Sherbrooke, P. Q.—Manufacturers of all kinds of Bobbins and Spools for Cotton and Woollen Mills—Special patterns made to order from sample.

Bridge Builders.

DOMINION BRIDGE CO. (Limited),—Shops at Toronto, Ontario, and Lachine, Quebec. Builders of Steel and Iron Railway and Highway Bridges.

Chemicals.

DOMINION DYEWOOD AND CHEMICAL CO., Toronto.—Importers and Manufacturers. Chemicals for Cotton, Woollen, Paper and Leather Manufacturers.

MCARTHUR, CORNEILLE & CO. (successors to John McArthur & Son), Montreal.—Offer at closest figures chemicals required by soap-boilers, oil refiners, paper-makers, and by manufacturers of woollens, cottons, leather, &c.

Cotton Mills.

HAMILTON COTTON MILLS CO., Hamilton.—Denims, tickings and yarns.

Dyes, Dyeing Drugs and Extracts.

THEO. H. EATON & SON, Windsor, Ont.; Detroit, U. S. A.—Carry full line of Pure Dyeing Drugs, Dye Woods and Extracts adapted for the requirements of Woollen and Cotton Manufacturers. **Paper Makers' Anilines** and Chemicals. Address the Detroit Office.

Dye Stuffs.

MCARTHUR, CORNEILLE & CO. (successors to John McArthur & Son), Montreal.—Supply of best quality at closest prices. Every description of coloring materials required by manufacturers of woollens, cottons, silks, paper, leather, &c. Are sole agents in Canada for the celebrated aniline dyes of A. Porrier, Paris.

LYMAN BROTHERS & CO., Nos. 71 and 73 Front Street East, Toronto—Dye Stuffs of all kinds for Woollen and Cotton Manufacturers; Warps, Shuttles, Bobbins, Card Clothing, etc., etc.

Dyewood and Dye Stuffs, Aniline Dyes.

DOMINION DYEWOOD AND CHEMICAL CO., Manufacturers.—Pure Dyewoods, Dyeing Drugs. Sole Agents. English, German, and French Aniline Dyes, for Woollen, Silk Paper, and Leather manufactures.

Edge Tools.

WELLAND VALE MANUFACTURING CO.—Lock No. 2, St. Catharines, Ontario, Canada.—Manufacturers of axes, scythes, forks, hoes, rakes and edge tools.

Emery Wheels.

HART EMERY WHEEL CO., Hamilton.—Manufacturers of every description of Emery Wheels and Emery Wheel machinery.

Gas Engines.

JOHN DOTY, Toronto.—Manufacturer in Canada of the new "Otto" silent gas engine, two, four, and seven horse-power and larger.

Glove Manufacturers.

W. H. STOREY & SON, Acton, Ont.—Manufacturers of fine gloves and mitts in every variety and style.

Hoist and Elevator Manufacturers.

LEITCH & TURNBULL, Canada Elevator Works, cor. Queen and Peter Streets, Hamilton, Ont.—Patent Safety Hydraulic, Hand, and Power Elevators. Telephone connection.

Hubs, Spokes and Bent Goods.

F. W. HORE & SON, Hamilton, Ont.—Manufacturers of wheels, wheel material, shafts, poles, etc.

COWAN & CO., Galt.—Manufacturers of every description of wood working machinery.

H. R. IVES & CO., Montreal.—Hardware manufacturers and founders; iron ruling and ornamental iron work a specialty.

JOHN BERTRAM & SONS, Dundas.—Machine tools and wood working machinery. Toronto wareroom, 58 Yonge St. Agents—The Polson Iron Works Co.

Montreal wareroom, Craig St. Agents for Quebec—The Machinery Supply Association, Montreal.

THE OSHAWA MALLEABLE IRON CO., Oshawa, Ont.—Manufacturers of malleable iron castings, to order, for all kinds of Agricultural Implements and miscellaneous purposes.

SMITH'S FALLS MALLEABLE IRON WORKS, Smith's Falls, Ont.—Manufacturers to order of refined malleable iron castings from air furnace. Agricultural and other heavy castings a specialty. Carriage castings in stock.

Engines and Boilers.

JOHN DOTY, Toronto.—Engines and boilers of every description and capacity, also shafting, pulleys, and hangers for factories.

Knife Works.

THE WHITMAN & BARNES MANUFACTURING CO., St. Catharines, Ont.—Manufacturers of mowing and reaping machine knives, sections, guard plates, cutting apparatus complete, spring keys and cutters, etc.

Knitting Mills.

S. LENNARD & SONS, Dundas.—Manufacturers of plain and fancy hosiery.

Manufacturers' Supplies.

E. JENCKES MANUFACTURING CO., Pawtucket, R. I.—Sole manufacturers of Hicks Improved U. S. Standard Ring Travellers. Belt hooks, gimlet pointed wire goods, spinning rings, cotton banding, twine, &c. Manufacturers' supplies. Leather belting and lace leather. Special agents for Jos. Noone's sons cloths.

Oils.

MCARTHUR, CORNEILLE & Co (successors to John McArthur & Son), Montreal.—Afford best value in pure olive and lard oils, also in all other leading lines of vegetable, animal, and mineral oils for factory use. Invite special attention to their celebrated crown diamond "engine" and "machinery" oils.

Paper Manufacturers.

WM. BARBER & BROS., Georgetown—Manufacturer of book and fine papers.

THE TORONTO PAPER MANUFACTURING CO., Cornwall, Ont.—Manufacturers of engine sized superfine papers, white and tinted book papers, blue and cream laid and wove foolscaps, account book, envelope and lithographic papers, etc., etc.

Saw Manufacturers.

R. H. SMITH & CO., St. Catharines.—Manufacturers of all kinds of saws, plastering trowels, straw knives, etc. Sole manufacturers for the Dominion of Canada of the celebrated "Simond's Saw."

Scythe Snaths.

THE DOMINION SNATH COMPANY, Sherbrooke, Que.—Manufacturers of Patent Swing Socket, and every variety of Scythe snath.

Tanners' and Wool Pullers' Supplies.

THEO. H. EATON & SON, Windsor, Ont.; Detroit, U.S.A.—Supply at lowest prices all Chemicals used by Tanners and Wool Pullers. Special Anilines for Sheep Skin Dyers, Wool Mat Manufacturers, etc., etc. Address correspondence to Head Office, Detroit, Mich.

Taps and Dies.

BUTTERFIELD & CO., Rock Island, P. Q.—Manufacturers of Taps, Dies, and all Screw Cutting Tools.—Telegraph Office, Derby Line, Vt.

Wire Works.

B. GREENING & CO., Hamilton, Ont.—Manufacturers of wire ropes, cloth and general wire workers.

TIMOTHY GREENING & SONS, Dundas, Ont.—Manufacturers of the strongest description of steel wire cloth, malt kiln floors and general wire weavers. Telephone connection.

PATENTS

MUNN & CO., of the SCIENTIFIC AMERICAN, continue to act as Solicitors for Patents, Caveats, Trade Marks, Copyrights, for the United States, Canada, England, France, Germany, etc. Hand Book about Patents sent free. Thirty-seven years experience.

Patents obtained through MUNN & CO. are noticed in the SCIENTIFIC AMERICAN, the largest, best and most widely circulated scientific paper. \$5.00 a year. Weekly. Splendid engravings and interesting information. Specimen copy of the Scientific American sent free. Address MUNN & CO., SCIENTIFIC AMERICAN Office, 361 Broadway, New York.

TO ADVERTISERS!

For a check for \$20 we will print a ten-line advertisement in One Million issues of leading American Newspapers and complete the work within ten days. This is at the rate of only one-fifth of a cent a line, for 1,000 Circulation! The advertisement will appear in but a single issue of any paper, and consequently will be placed before One Million different newspaper purchasers;—or FIVE MILLION READERS, if it is true, as is sometimes stated, that every newspaper is looked at by five persons on an average. Ten lines will accommodate about 75 words. Address with copy of Adv. and check, or send 30 cents for Book of 272 pages. GEO. P. ROWELL & CO., 10 SPRUCE ST., NEW YORK.

We have just issued a new edition (the 16th) of our Book called "Newspaper Advertising." It has 272 pages, and among its contents may be named the following Lists and Catalogues of Newspapers:—

DAILY NEWSPAPERS IN NEW YORK CITY, with their Advertising Rates.

DAILY NEWSPAPERS IN CITIES HAVING more than 10,000 population, omitting all but the best.

DAILY NEWSPAPERS IN CITIES HAVING more than 20,000 population, omitting all but the best.

A SMALL LIST OF NEWSPAPERS IN which to advertise every section of the country: being a choice selection made up with great care, guided by long experience.

ONE NEWSPAPER IN A STATE. The best one for an advertiser to use if he will use but one.

BARGAINS IN ADVERTISING IN DAILY Newspapers in many principal cities and towns, a List which offers peculiar inducements to some advertisers.

LARGEST CIRCULATIONS. A complete list of all American papers issuing regularly more than 25,000 copies.

THE BEST LIST OF LOCAL NEWSPAPERS, covering every town of over 5,000 population and every important county seat.

SELECT LIST OF LOCAL NEWSPAPERS, in which advertisements are inserted at half price.

472 VILLAGE NEWSPAPERS, in which advertisements are inserted for \$41.40 a line and appear in the whole lot—one-half of all the American Weeklies.

Sent to any address for THIRTY CENTS.



THE GALT FOUNDRY,

Engine and Machine Works.

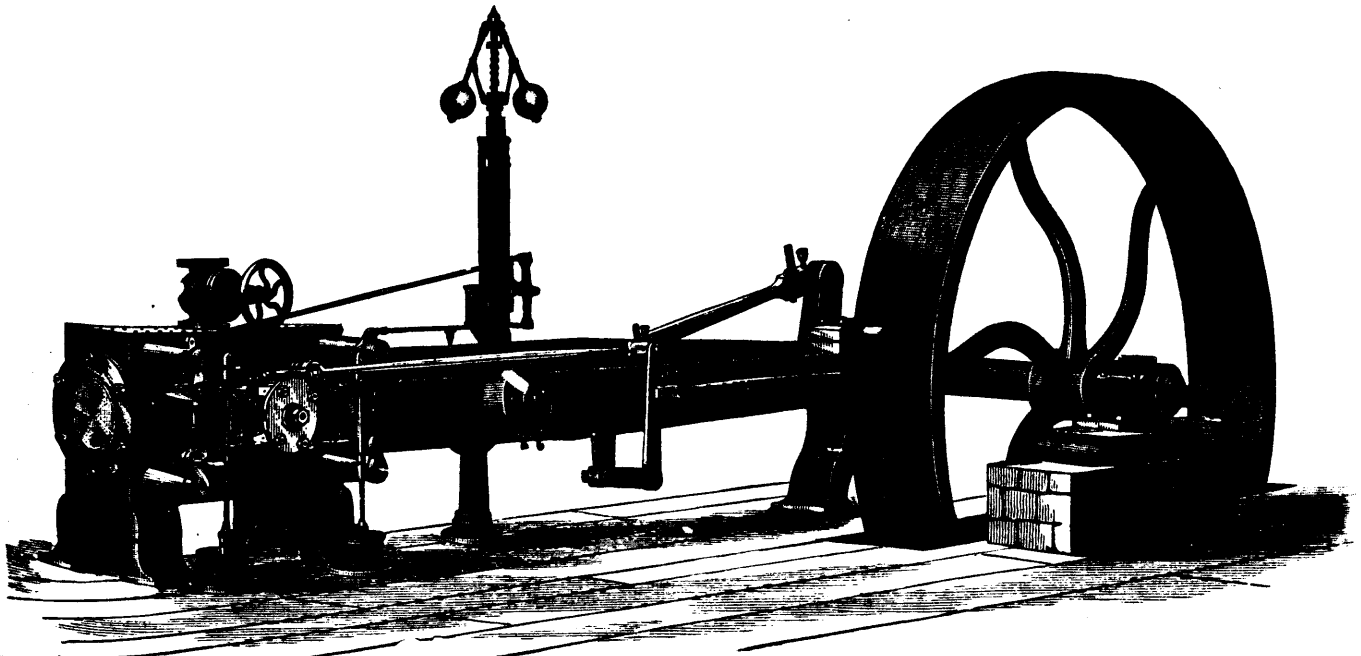

THE HARRIS-CORLISS STEAM ENGINE

Is the most perfect Cut-off Engine made. For Economy of Fuel, Regulating of Speed, Accessibility of all its Parts, it has many Imitators, but no Equals, and is Unsurpassed.

While many Engines of the same class have been invented, built, tried and abandoned, the Harris-Corliss has steadily gained in public favor, and is now

Without a Successful Rival.

PLEASE NOTICE SOME OF THE ADVANTAGES OF THE HARRIS-CORLISS ENGINE:

- 1st—The Steam is admitted at Boiler pressure to the piston by the main valve and is cut off at the same point, the load determining through the regulator, when the supply of steam shall be cut off. This is the only Engine that thus admits steam at full boiler pressure.
- 2nd—The success of the Harris-Corliss Engine lies in the simplicity and precise action of the governing elements; the Governor is an independent mechanism, with no extraneous load, and free to instantly respond to all variations in the angular velocity of rotating parts.
- 3rd—No parts of the regulating medium enter the steam chest and thereby be out of sight of the engineer, and subject to the corrosive action of steam and the oil used for lubricating the valves and piston.
- 4th—Regularity of Speed under varying loads of steam pressure.
- 5th—Recessed Valve Seats which avoid the liability of wearing shoulders on them.
- 6th—Stop Motion on Regulator of Engine which effectually stops the Engine whenever the regulator by any means fails to perform its work, thus preventing the Engine from running away.
- 7th—Having four Valves either can be adjusted independently of the other with the greatest ease.
- 8th—The increased amount of power it develops.

We would draw special attention to our new and improved Adjustable Pillow Block, which is pronounced by all practical men who have seen it, to be the very best in Canada.

COWAN & CO.,
Galt, Ont., Canada.

Manufacturers of Engines, Boilers and Wood-Working Machinery—all kinds, new Patterns, highly finished.



Notice to Contractors.
SAULT SAINTE MARIE CANAL.

CONTRACTORS intending to tender for works of construction of the canal proposed to be formed on the Canadian side of the Sainte Mary's River, are hereby informed that tenders will be received about **JANUARY NEXT**, and that the most favorable time to examine the locality will be between the present time and the early part of November next.

When plans, specifications and other documents are prepared, due notice will be given. Contractors will then have an opportunity of examining them and be furnished with blank forms of tender, etc.

By order,
A. P. BRADLEY,
Secretary.

Department of Railways and Canals, }
Ottawa, 24th August, 1887. }

Maw & McFarlane
DUNDAS, ONT.

IRON FOUNDERS, ENGINEERS AND MACHINISTS,
MANUFACTURERS OF

Drop Hammers,
LIFTERS, DIE SINKERS AND PRESSES.

CORRESPONDENCE SOLICITED.

TORONTO LITHOGRAPHING CO.
Globe Building, Toronto
MAKE SPECIALTY OF
Fine Color Work
CHROMO ADVERTISING
CARDS and NOVELTIES
also do a Superior Class of Wood Engraving

VICTORIA WIRE MILLS.

ESTABLISHED - 1859.

BANK
AND
OFFICE
Counter Railings
IN
Brass & Iron.

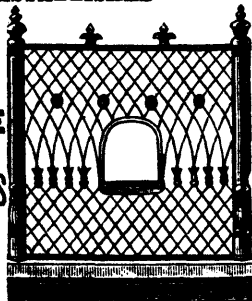

WIRE
Window Guards
AND
Fine Wire Blinds
FOR
Inside Windows.
MANUFACTURED BY

B. GREENING & CO., Hamilton, Ont.

Send for Catalogue.

HAMILTON
COTTON COMPANY,

MANUFACTURERS OF

THE STAR BRAND

COTTONADES, DENIMS, TICKINGS.

- Star Brand**—BEAM WARP.
" HOSIERY YARN
" BUNDLE YARN.
" CARPET WARP.
" BALLED KNITTING YARN.

First Prize, Silver Medals, for Beam Warps and Denims
Toronto, 1881.

General Agents,—
F. McELDERY & CO.,
204 MCGILL STREET, MONTREAL.
22 & 24 COLBORNE ST., TORONTO.

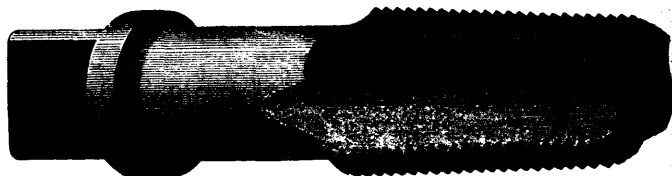

BUTTERFIELD & CO.

ROCK ISLAND, P.Q.

MANUFACTURERS OF

PIPE TAPS, CREAMERS

Pipe Stocks and Dies, Tongs, Cutters, Vises,
and Labor-Saving Tools for Blacksmiths',
Carriage Makers', Machinists'
and Gasfitters' Use.

Send for Illustrated Catalogue, 1887

NAME THIS PAPER.

Cobban Manufacturing Co. Factory & Head Office: Toronto.

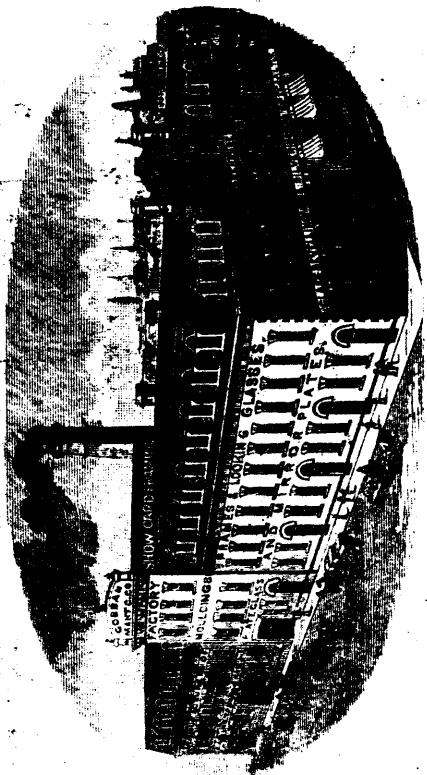

Branch: 455 St. Paul Street, Montreal.

MANUFACTURERS OF
Mantles, Over Mantles and Mirrors in Finest Hardwoods. Mouldings, Picture
Frames and Looking Glasses. Mirror Plates: British, French, German,
Shocks. Plate Glass Beveling and Silvering a Specialty.

TORONTO.
MONTRÉAL.
CLOSE PRICES. LIBERAL TERMS.

ONTARIO BOLT CO., TORONTO,

MANUFACTURE

- Threshing Machine Teeth,
- Machine Bolts,
- Bolt Ends and Blank Bolts,
- Bridge Rods and Bridge Rivets,
- Coach Screws and Skein Bolts,
- The Superb Carriage Bolt,
- The Prize Carriage Bolt,
- The Eclipse Carriage Bolt,
- The Prize Tire Bolt,
- The Eclipse Sleigh Shoe Bolt,
- The Prize Plough Bolt,
- Best Whiffletree Bolts,
- Best Shaft and Step Bolts,
- Best Eccentric Head Spring Bolts,
- Best Elevator Bolts,
- Best Norway Shackle Bolts,
- Best Railway Track Bolts,
- Black Iron Rivets,
- Boiler Rivets,
- Railway Spikes,
- Pressed Spikes,
- Hot Pressed Nuts,
- Bridge Bolts and Rag Bolts.

HEINTZMAN & CO.

MANUFACTURERS OF

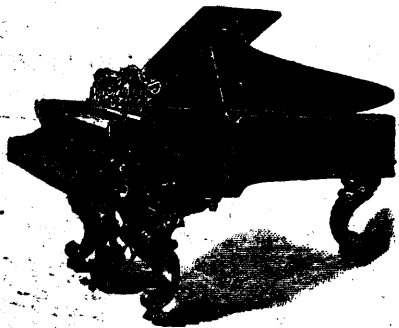

**GRAND,
SQUARE,
AND UPRIGHT
PIANOFORTES.**

SEND FOR ILLUSTRATED CATALOGUE.
Warerooms, - 117 King St. West,
TORONTO.



**HART
Emery Wheel**

COMPANY
(LIMITED)

Hamilton, Canada.

MANUFACTURERS OF

EMERY WHEELS

FOR

**FOUNDRIES, MACHINE SHOPS,
SAW MILLS, & PLANING MILLS.**
SEND FOR CIRCULAR.

Also
MANUFACTURERS
OF

**EMERY WHEEL
MACHINERY.**

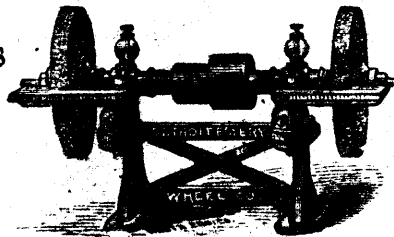

Illustrated Price List sent on Application.

W. STAHLSCHEMIDT & CO.

PRESTON, ONT.

MANUFACTURERS OF

School, Office, Church and Lodge
Furniture.

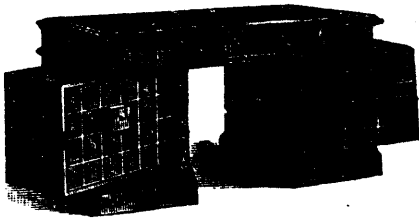

ROTARY DESK

No. 50.

Send for Circulars and Price List. Name this
paper.

S. Lennard, Sons, & Bickford,

DUNDAS, ONT.

PATENTEES OF THE "ELYSIAN" SEAMLESS HOSIERY.

Manufacturers of Plain and Fancy
Hosiery, Caps, Tugues, Sashes,
etc., etc., etc.,

To the Wholesale Trade only.

Represented in Eastern Ontario, Que-
bec, Nova Scotia and New Brunswick
by

F. W. NEWMAN & CO.,
21 Lemoine St., Montreal.

In Manitoba by
PEDDIE & CO.,
WINNIPEG, MANITOBA.

In Western Ontario by
S. LENNARD,
Senior Member of the Firm.

ESTABLISHED 1820.

EAGLE FOUNDRY.

GEORGE BRUSH,

14 TO 84 KING AND QUEEN STREETS, MONTREAL,

Maker of

STEAM ENGINES,
STEAM BOILERS,
HOISTING ENGINES,
STEAM PUMPS,
CIRCULAR SAW MILLS,
BARK MILLS,
SHINGLE MILLS,
ORE CRUSHERS,
MILL GEARING,
SHAFTING,
HANGERS AND
PULLEYS,

HAND AND POWER HOISTS FOR
WAREHOUSES, &c., &c.,

and Agent for

"Water's" Perfect Steam Engine Governor, and
"Heald & Sisco's" Centrifugal Pumps.



EVERY REPUTABLE DEALER KEEPS
THEM.

Insist on having the Genuine, and see
that they bear our name.

LANSDOWNE PIANO CO.

UPRIGHTS
— AND —
SQUARES

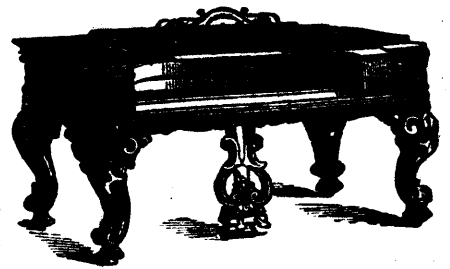

The Leading Canadian Pianos

STRICTLY FIRST-CLASS. Correspondence Solicited

86 York St., Toronto.

Established 1872.

THE ACCIDENT

INSURANCE CO. OF NORTH AMERICA.

NEW FEATURE,

JOINT INSURANCE

FOR PARTNERSHIPS

IMPORTANT TO MANUFACTURING FIRMS.

MEDLAND & JONES,

GENERAL AGENTS,

Corner Adelaide and Victoria Streets,

TORONTO.

J. M. LAUGHLIN'S SONS.

CROWERS
MERCHANTS,
AND EXPORTERS OF

SHANEATELES FALLS
N.Y.

AMERICAN TEASELS.

