

Technical and Bibliographic Notes / Notes techniques et bibliographiques

The Institute has attempted to obtain the best original copy available for scanning. Features of this copy which may be bibliographically unique, which may alter any of the images in the reproduction, or which may significantly change the usual method of scanning are checked below.

L'Institut a numérisé le meilleur exemplaire qu'il lui a été possible de se procurer. Les détails de cet exemplaire qui sont peut-être uniques du point de vue bibliographique, qui peuvent modifier une image reproduite, ou qui peuvent exiger une modification dans la méthode normale de numérisation sont indiqués ci-dessous.

- Coloured covers /
Couverture de couleur
- Covers damaged /
Couverture endommagée
- Covers restored and/or laminated /
Couverture restaurée et/ou pelliculée
- Cover title missing /
Le titre de couverture manque
- Coloured maps /
Cartes géographiques en couleur
- Coloured ink (i.e. other than blue or black) /
Encre de couleur (i.e. autre que bleue ou noire)
- Coloured plates and/or illustrations /
Planches et/ou illustrations en couleur
- Bound with other material /
Relié avec d'autres documents
- Only edition available /
Seule édition disponible
- Tight binding may cause shadows or distortion
along interior margin / La reliure serrée peut
causer de l'ombre ou de la distorsion le long de la
marge intérieure.
- Additional comments /
Commentaires supplémentaires:

Continuous pagination.

- Coloured pages / Pages de couleur
- Pages damaged / Pages endommagées
- Pages restored and/or laminated /
Pages restaurées et/ou pelliculées
- Pages discoloured, stained or foxed/
Pages décolorées, tachetées ou piquées
- Pages detached / Pages détachées
- Showthrough / Transparence
- Quality of print varies /
Qualité inégale de l'impression
- Includes supplementary materials /
Comprend du matériel supplémentaire
- Blank leaves added during restorations may
appear within the text. Whenever possible, these
have been omitted from scanning / Il se peut que
certaines pages blanches ajoutées lors d'une
restauration apparaissent dans le texte, mais,
lorsque cela était possible, ces pages n'ont pas
été numérisées.

The Canadian Patent Office

RECORD

Vol. XV.—No. 7.

JULY, 1887.

{ Price in Canada \$2.50 per An.
 { United States - \$2.50 "

CONTENTS.

| | |
|--------------------------|-----|
| INVENTIONS PATENTED..... | 331 |
| ILLUSTRATIONS | 363 |
| INDEX OF INVENTIONS..... | I |
| INDEX OF PATENTEES..... | II |

INVENTIONS PATENTED.

NOTE—Patents are granted for 15 years. The term of years for which the fees have been paid, is given after the date of the patent.

No. 26,795. Dining Car. (*Char réfectoire.*)

James H. Elliott, Montreal, Que., 1st June, 1887; 5 years.

Claim.—1st. In a coach of the class described, a double dining-room arranged at the end thereof, and divided into two separate distinct compartments by a transverse partition, one division of the dining-room communicating directly with the passenger-compartment, and the other directly with the platform, and a kitchen communicating by wickets with each of said separate compartments, substantially as specified. 2nd. In a coach of the class described, separate dining-rooms arranged at the end thereof, and a kitchen arranged at one corner of the coach, and provided with communicating wickets for each of the dining-rooms, substantially as specified. 3rd. In a coach of the class described, a kitchen arranged at one corner and along the side, a transverse partition extending from the wall of the kitchen to the opposite wall of the coach, and provided with a door and curved counters arranged between said door and the wall of the kitchen, whereby an unobstructed passage is provided from the platform to the main portion of the coach, substantially as specified. 4th. In a coach of the class described, a kitchen located at the corner of the coach and along a portion of its side, and separated by a curved partition provided with wickets, a transverse partition extending from the opposite wall of the coach to the kitchen-wall, and to a point between the wicket, substantially as specified.

No. 26,796. Running Gear for Road Wagons. (*Train de wagons routier.*)

Cyrus W. Saladee, Cleveland, Ohio, U.S., 1st June, 1887; 5 years.

Claim.—1st. In a road wagon, the combination, with a spring perch, consisting of two similar flexion members arranged side by side extended to connect the axles, and the axle-stays P, P constructed and arranged to operate substantially as set forth. 2nd. In a road wagon, the combination, with a spring perch, the axle-stays P, P having their front ends rigidly attached to the centre portion of the perch, and their rear ends pivotally connected to the hind axle at or near the opposite shoulders thereof, substantially as set forth. 3rd. In a road wagon, the combination, with a spring perch, the axle-stays P, P having their front ends secured to the central portion of the spring perch, and their rear ends V pivotally connected to the hind axle at a point below the line of the pivotal bearing D supporting the rear end of the perch, substantially as and for the purpose set forth. 4th. In a road wagon, a fifth wheel coupling consisting of the upper circle A, provided with the rearwardly extended arm D, trunnion bolt M, and the bottom circle B, substantially as set forth. 5th. In combination, with the fifth wheel, circles A and B, the under-brace E, its rear end supporting the rearwardly extended arm D of the upper circle A, its front end supporting the circle plates A and B in front of the axles, and the clip king-bolt G, all combined and arranged to operate substantially as set forth. 6th. In combination with the fifth wheel circle-plates A and B, the under-brace E having its front ends secured in front of the axle to the circle-plates by bolts 1 and 2, the latter having their thread cut in the end of the brace E and locked therein by set-nuts 1 and 2, substantially as specified.

No. 26,797. Telephony. (*Téléphonie.*)

James W. Bonta, Philadelphia, Penn., U. S., 1st June, 1887; 5 years.

Claim.—1st. The art or method of transmitting vocal or other

sounds telephonically, by causing intermittent or pulsatory currents of a uniform volume or intensity, and of duration corresponding to the phases of the oscillations of the diaphragm. 2nd. The method of transmitting vocal or other sounds telephonically, by causing electrical impulses of constant volume, and of durations corresponding to the elements of the sound, force or waves, substantially as set forth. 3rd. The method of transmitting vocal or other sounds telephonically, by causing electrical impulses which differ in duration with the overtones, and fundamentals of the vocal or other sounds, substantially as set forth.

No. 26,798. Fence. (*Clôture.*)

Cyrus Crabbs, Markham, Ont., 1st June, 1887; 5 years.

Claim.—The boards or rails A connected together by the vertical pieces B, in combination with the slanting stakes D, driven into the ground on either side of the fence and tied together in pairs by the tie-pieces F, substantially as and for the purpose specified.

No. 26,799. Steam Boiler. (*Chaudière à vapeur.*)

Allen Calhoun, Middlebury, Vt., U.S., 1st June, 1887; 5 years.

Claim.—1st. A steam-boiler having the following elements, viz: an outer shell or casing, two water-chambers of a width equal to the distance between the side walls of said casing, and a length considerably less than the distance between the front and rear walls of said casing, said chambers being arranged horizontally one above the other and equidistant from said front and rear walls, a series of vertical water-tubes connecting said chambers, a series of fire-tubes extending longitudinally through each of said chambers from front to rear, and partitions extending from one end of each of said chambers to the wall of said casing below the fire-tubes, and from the other end of each of said chambers to the casing above the fire-tubes, substantially as described. 2nd. In a steam-boiler, the combination of two water-chambers located within an outer shell, and connected together by a series of water-tubes, a series of fire-tubes extending from end to end of each of said chambers, and a series of partitions between the ends of said chambers and the front and rear walls of said casing, whereby the products of combustion are caused to pass in succession along the lower surface of a chamber, and through the fire-tubes of said chamber along the upper surface of one chamber and the lower surface of the other chamber, through the fire-tubes of the upper chamber and along the upper surface of said upper chamber, substantially as described.

No. 26,800. Clod Crusher and Pulverizer.

(*Rouleau brise-motte.*)

David Lubin, Sacramento, Cal., U.S., 1st June, 1887; 5 years.

Claim.—1st. The combination, with a series of spiked wheels, of a series of adjacent crushing-bars between said wheels, said bars being formed of spring metal, and having curved or rounded front surfaces, whereby they yield to permit the passage of an obstruction, substantially as and for the purpose specified. 2nd. In a clod-crusher, the combination, with a main frame, a main shaft and a supplemental frame A projecting from said shaft, of a series of spiked wheels or disks, and a series of adjacent crushing-bars secured to said shaft and supplemental frame, said bars having curved or rounded front ends and a curved or Q-shaped rear end, substantially as described. 3rd. The combination, with a series of rotating spiked wheels or disks, of a series of adjacent crushing devices having a centrally projecting preliminary crushing edge, substantially as herein described. 4th. The combination, with a series of rotating spiked wheels, of an adjacent series of crushing devices having crushing shoes, with a projecting rib or preliminary crushing edge, substantially as described. 5th. The combination, with a series of rotating wheels having flat teeth projecting therefrom, of a series of rearwardly curved crushing-bars pressing upon the ground and crushing the clods between their lower surfaces and the adjacent teeth, substantially as specified. 6th. A main frame, the wheels supporting said frame, and a main shaft having a series of spiked wheels thereon, in combination with a supplemental frame extending rearwardly from said shaft, a series of springs rearwardly curved crushing-bars carried by said frame and means for elevating the said supplemental frame and crushing-bars, substantially as herein de-

scribed. 7th. The combination, with a series of wheels having teeth projecting therefrom, of a corresponding series of crushing devices, and a series of adjustable spring arms adapted to engage the space between said teeth, substantially as herein described and for the purpose set forth. 8th. The combination, with a series of wheels having teeth or projections extending therefrom, of an adjacent series of crushing devices, a laterally adjustable bar mounted in the main frame, and a series of adjustable spring arms extending from said bar and engaging the spaces between the teeth, substantially as and for the purpose described.

No. 26,801. Self-Binding Harvester.

(Moissonneuse-lieuse.)

Alexander Turnbull, London, Ont., 1st June, 1887; 5 years.

Claim.—1st. A sleeve G formed with a feather G¹, in combination with a ratchet F and shaft D₂ for the purposes of conveying motion to the binding mechanism, when said binding mechanism is adjusted to any position required to suit different lengths of grain. 2nd. The feathered sleeve G and ratchet F, in combination with the dog o₆ and chain wheel B₃, for the purpose of conveying motion to said chain-wheel. 3rd. A notched crank o₂, in combination with the compressor-shaft o₁, connecting rod P₂, compressor cam P₁ and lever o₃ for the purpose of engaging the latter with or disengaging it from the dog o₆, which throws the binding mechanism in and out of gear. 4th. A lever o₃, friction roller o₄ and crank o₂ in which a notch o₅ is formed, in combination with a compressor shaft o₁, compressor arm o and compressor cam P₁, substantially as shown and described and for the purpose set forth. 5th. The carrier operating shaft D₁, provided with a double crank I, for the purpose of operating the cutter bar. 6th. A projecting arm or butt packer K attached to and operated by the pitman T₁ which operates the cutter bar, said packer being for the purpose of freeing the elevators and straightening the grain on the binding table while the sheaf is being formed. 7th. A hinged flap L, in combination with the binding table L₂, spring L₁ and stationary bar L₂, for the purpose of freeing the butt packer when the table is adjusted to bind short grain. 8th. The opening between the elevators at the outer end, which opening permits the heads of long grain to be carried up and through the elevators, without being bruised and also prevents the elevators from being choked. 9th. In a twine knitter, a stripper A⁵ having an oblique movement, for the purposes specified. 10th. A stripper formed with an aperture T₁ and lip T₂ for the purpose of holding the cord, substantially as described. 11th. A blade T attached to the stripper A⁵, in combination with a cord or twine guide A⁵ formed with a cutting notch Z for cutting the cord, substantially as described. 12th. A twine or cord guide A₅, the outer face of which is shaped to guide the cord to the knotting hook, substantially as described. 13th. A stripper A⁵, formed with an arm T₁, in combination with a breast plate T₃, formed with a slot W having an oblique angle W₂ which governs the motion of the stripper, substantially as described. 14th. A cord or twine guide A₅, formed with a curved face a₃ to guide the cord to the knotting hook, and with a cutting notch Z to assist in severing the cord, substantially as set forth. 15th. The cam A₄ for operating, the elbow A₃ and stripper A⁵, substantially as set forth. 16th. A wheel D₄, formed with cog segments a₁ and a₂ for operating the knotting hook D₅, and the cord holding disk A₂ respectively, substantially as set forth. 17th. In combination with the bevelled D₆, a pitman D₉, or its substantially equivalent, for the purpose of operating the cord holding disk A₂, substantially as set forth. 18th. A pitman D₉, formed in two parts for the purpose of lengthening or shortening the same, substantially as shown and described and for the purpose specified. 19th. A swinging link D₁₀, in combination with a pitman D₉, for the purpose of holding a dog D₁₂, and operating a ratchet A₁ and cord-holding disk A₂, substantially as described.

No. 26,802. Hitching Gear for Vehicles.

(Appareil de dételage instantané.)

James L. Turnbull, Bellwoods Station, Ont., 1st June, 1887; 5 years.

Claim.—1st. The spring bolts A, designed to secure the traces C, as indicated, in combination with the cords D, arranged substantially as and for the purpose specified. 2nd. The spring bolts A, designed to secure the traces C, as indicated, in combination with the cords D passing around the pulleys E and connected to the cord F, carried through the dash-board G, substantially as and for the purpose specified. 3rd. The grooved brackets F, connected to the shafts I, in combination with the eye-bolts K, to which the breeching-straps H are attached, substantially as and for the purpose specified.

No. 26,803. Self-Acting Car-Coupler.

(Attelage de chars automatique.)

Thomas Turnbull, West Luther, Ont., 1st June, 1887; 5 years.

Claim.—The draught-pin B, located within the draw-head A and actuated by the spring E, in combination with the block F located within the draw-head A and operated by the spring G, substantially as and for the purpose specified.

No. 26,804. Car-Coupling. (Attelage de chars.)

John W. Jackson, North Haverhill, N. H., U. S., 1st June, 1887; 5 years.

Claim.—1st. The combination, with the lifter D having a central bend, and a crank d, of the inclined loop E permitting the lifter to slide back and supporting the same, the slotted fastening plate J and the link B, as set forth. 2nd. The combination, with the coupling-pin C, of the chain H, the segment I, having groove i and weight i, the rock-shaft J and weighted cranks K, K, as set forth.

No. 26,805. Automatic Clothes Washer.

(Laveuse mécanique à linge.)

William H. Perrin and James O. Church, Smith's Falls, Ont., 1st June, 1887; 5 years.

Claim.—An automatic clothes-washer, having the base A, wings J, pipe C and zinc plate d, all substantially as shown and described and for the purpose set forth.

No. 26,806. Device for Detaching Horses from Vehicles. (Appareil pour dételé les chevaux.)

Hezekiah Lathaw and Henry J. Stiefelmeyer, New Hamburg, Ont., 1st June, 1887; 5 years.

Claim.—1st. The combination, with the shafts A, of the whiffletree C provided with levers E, E, at the ends, and having a fish-tail projection to receive the trace, covered ways H having locking slides J engaging with the inner end of the levers, straps L connecting the slides and strap M to be pulled by the driver to disengage the slides simultaneously, whereby the levers will then offer no resistance to the traces, as set forth. 2nd. The combination, with the shafts A, of the plate P provided with barrel Q and hook R, and having a piston T and spring U to retain and release the breeching, as set forth.

No. 26,807. Car Brake. (Frein de char.)

Earl A. Westcott and Edmond R. Bristol, Minneapolis, Minn., U.S., 1st June, 1887; 5 years.

Claim.—1st. The combination, with the air-pipes of an atmospheric brake provided with valves, of a truck having a series of vertically-operating rods hung in guides thereon, the upper end of each rod connected directly with the levers of an air pipe and longitudinal beams secured to the lower ends of said rods, as set forth. 2nd. The combination, with the air-pipes of an atmospheric brake, provided with valves, of a truck, having a series of vertically-operating rods, the upper end of each rod connecting with an air pipe valve, and longitudinal beams convex upon their under sides and secured to the lower end of said rods, as set forth. 3rd. The combination, with the air pipes of an atmospheric brake provided with valves, of a truck having a series of inwardly-projecting guides upon its pedestal brace, a series of rods vertically operative in said guides and connected to the air-pipe valves, and longitudinal beams having their respective ends each secured to a rod, and provided upon their under faces with fender plates, as set forth.

No. 26,808. Harrow and Pulverizer.

(Herse brise-motte.)

Samuel Rothchild, Pendleton, Oregon, U.S., 1st June, 1887; 5 years.

Claim.—1st. The combination, with the diagonal toothed side bars A, of the revolving wheels C, having teeth whose length exceeds that of the teeth of said bars, and arranged and secured at the angle specified between the separable parts or sections of said bars, as shown and described. 2nd. The improved harrow and pulverizer, consisting of the diagonal sectional frame A, having vertical stationary teeth, the series of frames D and revolving wheels C arranged at an angle of 45° to said diagonal frame, and having teeth, whose length exceeds that of said vertical teeth, as shown and described. 3rd. The improved protector for the toothed wheels, the same consisting of a flexible band and a series of hoods attached to its inner side, as shown and described.

No. 26,809. Harrow. (Herse.)

John Evans, Cayuga, Ont., 1st June, 1887; 5 years.

Claim.—1st. The combination, with the bulls 1, of the tooth-holder 3 sleeved thereon, tooth 2 intersecting the bull pipe 8 intervening the bulls and bolt, and nut 10, 11, whereby the tooth will be clamped in the holder by the bull, and the bulls firmly connected by screwing the nut and the tooth be capable of adjustment to any desired height, as set forth. 2nd. The tooth-holder 3, having an opening to receive the bull, sockets 4 in the sides of the opening to partly intersect the bull and receive the tooth bar 5 at one end, and bearing 6, provided with socket 7 surrounding a bolt hole to clamp the holder and tooth to the bull, in the manner set forth.

No. 26,810. Heat Producing Apparatus.

(Appareil pour produire la chaleur.)

George E. Benninghoff and Collin F. Jewell, Kindall Creek, Penn., U.S., 1st June, 1887; 5 years.

Claim.—1st. The combination of the forge or furnace having a combustion chamber, the air and gas supply pipes, the oxygenizers or chambers for mixing the air and gas passed through the air and gas supply pipe, and the conduits extended thence through the forge or furnace wall to the combustion chamber, in a manner to conduct the mixed air and gas into the combustion chamber, substantially as and for the purpose hereinbefore set forth. 2nd. The combination of a forge or furnace, having a combustion chamber, the air and gas supply pipes, the oxygenizers or chambers for mixing the air and gas passed through such pipes, and the conduits extended thence through the furnace wall for conducting currents of mixed air and gas concentrically into the combustion chamber, and distributing the combustion to all parts of or locating the heat of the same in any desired part of the chamber, substantially as specified. 3rd. The combination, with a forge or furnace having a combustion chamber, air and gas supply pipes, oxygenizers and conduits arranged to deliver mixed air and gas horizontally into the combustion chamber, and air and gas supply pipes, oxygenizers and conduits arranged to deliver mixed air and gas horizontally into the combustion chamber, and air and gas supply pipes, oxygenizers and conduits arranged to deliver mixed air and gas concentrically into the combustion chamber, of the conduit connected with the lower air supply pipe, and suitably extended thence through the body of the forge or furnace to the combustion chamber for assisting the blending of the different currents introduced into the combustion chamber through the other conduits, and giving vertical direction to the heat accruing from the combustion of the air and gas in the combustion chamber, substantially as specified.

No. 26,811. Car-Coupler. (*Attelage de chars.*)

John B. Wilson, Marquette, Mich., U.S., 1st June, 1887; 5 years.

Claim.—1st. The combination of a draw-head with a pendulum latch, the latter being supported upon the inner ends of crank arms, the crank handles of which turning in opposite directions balance each other, substantially as described. 2nd. The pendulum latch, having ears upon its upper end, through which the crank arms are secured by pins or keys, in combination with a draw-head, through the side walls of which such crank-arms pass, substantially as specified. 3rd. The pendulum latch, having ears upon its upper end, the space between such ears forming a rest for the coupling pin, and from this point cut away upon an incline, in combination with a draw-head and crank arm, substantially as set forth.

No. 26,812. Combined Anti-Rattler and Thill Bolt Holder. (*Armon arrête-cheville de limonière.*)

John M. Peregrine (co-inventor with Obijah L. Romans), Jamestown, N.Y., U.S., 1st June, 1887; 5 years.

Claim.—1st. As a new article of manufacture, a combined anti-rattler and thill bolt holder, consisting of a fulcrumed spring, and a bolt-holding and tension lever formed with two arms, one to act upon the spring, the other to press against the bolt, the spring being arranged to act upon the thill eye and to react upon the lever, and formed with a cam or curve to hold the lever in position against the bolt, substantially as shown and described. 2nd. The clip-plate E, formed with the fulcrum *cl*, in combination with the spring G and lever F, arranged substantially as and for the purposes set forth. 3rd. The lever F, formed with the arms *f*, *h* at right angles to each other, in combination with the spring G, fulcrumed at *cl* and bent to press against the thill-eye and to be acted upon by the arm *h* of the lever, substantially as and for the purposes set forth. 4th. The spring G, formed with the two opposite extensions *g*, *g1*, and curved at *g2* and fulcrumed at *cl*, in combination with the lever F having arms *f* and *h*, substantially as and for the purposes set forth. 5th. The clip plate E, formed with fulcrum *cl* and stud *a*, in combination with the spring G bent to form extensions *g*, *g1*, and cam curve *g2*, and the lever F pivoted on stud *a* and formed with the arms *f*, *h*, the former for holding the thill-bolt, the latter for putting a tension on the spring G, substantially as and for the purposes set forth.

No. 26,813. Fruit Jar. (*Jarre à fruits.*)

Henry R. Bothwell and Frank T. Tinning, Toronto, Ont., 1st June, 1887; 5 years.

Claim.—In a fruit jar, provided with a movable cover, an air-tight joint formed between the jar and the cover by means of an angular projection formed on the top of the jar, and a corresponding groove formed in the face of the cover, the insertion of a rubber ring between the face of the cover and the top of the jar, and pressure brought to bear upon the top of the cover by means of a clamp drawn upon the rib of the same, substantially as and for the purposes set forth.

No. 26,814. Hay and Grain Loader.*(Monte-foin.)*

William H. Vantassel, Belleville (assignee of James Anderson, Ameliasburgh), Ont., 1st June, 1887; 5 years.

Claim.—1st. The combination, in a hay loader, of the several parts A, B, C, D of a hay rake, for the purposes specified. 2nd. In a hay loader, the combination of the attachment of the rake A, B, C, D, in which the rake teeth C extend over and behind the drum of the loader, as described and substantially as set forth.

No. 26,815. Kettle Handle. (*Anse de bouilloire.*)

Booth and Son, (assignees of George Booth), Toronto, Ont., 1st June, 1887; 5 years.

Claim.—A kettle bail composed of a metal tube bent into an appropriate form, and extending through a handle of wood or other non-conducting material, which is secured in position by metal caps fitted onto either end of the handle and rigidly secured to the metal bail, substantially as specified.

No. 26,816. Lumber Rule. (*Mesure à bois.*)

George Reid, jr., and John B. Reid, (assignees of John M. Clifford), Toronto, Ont., 1st June, 1887; 5 years.

Claim.—A lumber rule having a series of gauges a made in head B, substantially as and for the purpose specified.

No. 26,817. Method of Converting used Steel Rails into Nail Plate at one heat. (*Mode de conversion des vieux rails d'acier en fer à clou d'un seul coup.*)

Thomas Miller and James C. Robertson, Saint John, N.B., 1st June, 1887; 5 years.

Claim.—Such plates can be annealed by any process now in use.

No. 26,818. Screen. (*Ecran.*)

John W. Cheeseworth, and Joseph Ruse, Toronto, Ont., 1st June, 1887; 5 years.

Claim.—The combination with a screen having two or more hinged wings, of mirrors inserted in the panels of the screen, so that the same may be readily adjusted for the purpose of reflecting all parts of a figure into the mirror before which the figure is facing, substantially as and for the purpose specified.

No. 26,819. Sprinkler for applying Paris Green, etc., in liquid form to Potato Vines for the Destruction of Bugs. (*Arrosoir pour distribuer le vert de paris, etc., à l'état liquide sur les arbres de patates pour détruire la chrysome.*)

James H. Manhard, North Augusta, Ont 2nd June, 1887; 5 years.

Claim.—1st. A can A having a side indentation B, inlet D, outlet F and provided with strap connections L, as set forth. 2nd. The combination of the can A, shoulder strap C, hose G and sprinkler H, as set forth.

No. 26,820. Railroad Track Crossing.*(Croisement de voie de chemin de fer.)*

Frederick J. Hoyt, Chicago, Ill., U.S., 2nd June, 1887; 5 years.

Claim.—1st. A rotary track-crossing, provided on its face or faces with a rail, adapted to form a close and continuous connection with the rail of a main or branch track when rotated, substantially as described. 2nd. A rotary track-crossing, provided on its face or faces with a rail placed to form a close and continuous connection with the rail of a main or branch track, in combination with a switch-lever and shafts and gearing for operating said track-crossing, substantially as described.

No. 26,821. Water Purifier and Filter for Steam Boilers. (*Epurateur et filtre pour chaudières à vapeur.*)

John W. Hyatt, Newark, N.J. U.S., 2nd June, 1887; 5 years.

Claim.—1st In a water purifier for steam boilers, the combination: with a pump and filter operated to remove the impurities from the water, of a steam pipe applied to the suction pipe of the pump, and a pressure reducing valve in such steam pipe to reduce the steam pressure to that of the water supply, as and for the purpose set forth. 2nd. In a water purifier for steam boilers, the combination, with a pump and filter, operated to remove the impurities from the water, of the pipe *l* for delivering the boiler fluid to the suction of the pump, and provided with the pressure reducing valve *m* to reduce the pressure of the boiler fluid to that of the water supply, as and for the purpose set forth. 3rd. In a water purifier for steam boilers, the combination, with a feed pump *g*, of a circulating pump *c* of larger capacity, the pipe or passage *f* conducting the feed water from the feed pump to the circulating pump, and a pipe, as *l* or *n*, conducting the boiler fluid or the steam from the boiler to the pipe *f*, as and for the purpose set forth. 4th. The mixer for mingling steam and water consisting in the vessel *p* having inlets for the steam and water, and one of the inlets furnished with a closed wire coil to discharge the fluid within the chamber in thin films, as and for the purpose set forth. 5th. The filter having the bed of granular material C, the outlet strainer pipes E and the washer arm D, arranged below the strainer pipes E and movable around a central pivot, and provided with a water supply to wash the filter bed and with water outlets to discharge the water downward, substantially as set forth. 6th. In a filter, the construction for the outlet strainers consisting in the core KI having external longitudinal channels L, and metallic rings or coils applied over such channels with intermediate spaces for the passage of the water, substantially as set forth. 7th. In a filter, the construction for the washer arm consisting in the perforated tubular sleeve I, the arm D rotated upon the same by the shaft G, and the self-closing valves J inserted in apertures in the lower side of the arm, as and for the purpose set forth.

No. 26,822. Automatic Goods Selling Apparatus. (*Appareil de livraison automatique de marchandises.*)

Charles H. Russell, London, Eng., 2nd June, 1887; 5 years.

Claim.—1st. The combination, with a casing, a money slot and shoot, and a delivery aperture of a balanced money receiver, an escapement anchor pallets and wheel, a rotary drum with compartments for storing articles, and a spring or weight, all constructed and arranged substantially as and for the purposes set forth. 2nd. The combination, with a casing, a money slot and shoot, and a delivery aperture, of a balanced or movable money receiver, an escapement anchor pallets and wheel, a crank or eccentric, sliding slotted delivery device and out-off plate and a storage hopper, all constructed and arranged substantially as and for the purposes set forth. 3rd. In an automatic goods selling apparatus, the combination, with a moving delivery device, such as specified, of clock-work and escapement mechanism controlling same, and adapted to be actuated by the introduced coin, substantially as and for the purposes set forth. 4th. In an automatic goods selling apparatus, such as is set forth, the combination, with a money slot and moving delivery device, of a stop arm serving to actuate a vertical cranked lever, and a pivoted lever carrying a cover plate, all arranged to operate at the times in the manner and for the purposes set forth.

No. 26,823. Fishing Rod. (*Gaule de pêche.*)

Everett Horton, Bristol, Conn., U.S., 2nd June, 1887; 5 years.

Claim.—1st. A spring-tempered metallic tubular fishing-rod, substantially as set forth. 2nd. A spring-tempered tubular metallic tip for a fishing-rod, substantially as set forth. 3rd. A fishing-rod composed of spring tempered tubular metallic sections, constructed to telescope one within the other, in combination with a line passing through them, substantially as set forth. 4th. A fishing-rod consisting of two or more tapering spring-tempered tubular metallic sections, each consisting of a single long piece of metal folded transversely, substantially as set forth.

No. 26,824. Butter Dish Machine.*(Machine à faire les beurriers.)*

Frank M. Earle, Mexico, N.Y., U.S., 2nd June, 1887; 5 years.

Claim.—1st. In a device of the character herein specified, the scoring and feed rollers G, G', the pivoted cutting-plate A₁, the bed-plate adapted to said cutting-plate, and the folding mechanism combined, adapted and arranged to automatically operate, substantially as shown and described. 2nd. In a machine of the character herein specified, the scoring and feed rollers G, G', blank-cutting plate A₁, the bed-plate adapted to said cutting-plate, the folding mechanism, substantially as described, and the receiving receptacle, combined and arranged substantially as shown and described. 3rd. In a box-making machine of the character herein specified, the combination, with the pivoted blank-cutting plate A₁, and the bed-plate adapted thereto, the reciprocating folding plungers, the hinged folders and the receiving receptacles beneath said plungers, substantially as set forth. 4th. The combination of the main plunger p₁, the auxiliary plunger w₃, the hinged folders d₄ and the receptacle B₂, substantially as shown and described. 5th. In a machine of the character herein specified, the combination of the rollers G, G', feed-rollers I, J, the depressible former plate A₁, having cutting-edge a₁, and a₂, the bed-plate adapted to said former-plate p₁ and w₃, folders d₄, and receiving receptacle B₂, substantially as set forth. 6th. The scoring and feeding rollers which score the veneering on the under side thereof, and the former-plate and bed-plate provided with two sets of knives, the first for cutting the division-lines between the sides of the completed dish, and the second for cutting out the blank, in combination with folding mechanism, substantially as set forth. 7th. In a machine for making butter-dishes out of continuous strips of veneering, feeding mechanism, substantially as set forth, which feeds said veneering intermittently, scoring-rollers which score said veneering on the under side thereof, and a rising and falling former plate having two sets of cutting-knives, the set of knives next the scoring-rollers being arranged to cut the division-lines between the sides of the completed dish, and the second set being arranged to cut out the blank, in combination with the bed-plate adapted to said former-plate and the folding mechanism, substantially as set forth. 8th. The bed-plate and the former plate having knives arranged to cut out a blank from veneering previously scored and cut, said bed-plate having an opening beneath the knives over which the blank is cut out, in combination with a plunger-plate which is normally held within the knives of the former-plate, and mechanism substantially as set forth for depressing said plunger-plate, substantially as set forth. 9th. The plungers p₁ and w₃ and the folders d₄, in combination with the chute B₃ beneath said folders into which said plungers enter, said chute having straight sections e₁, e₂, and intermediate inclined folding section e₃, substantially as set forth.

No. 26,825. Process for Conveying Remedies to the Seat of disease.*(Procédé pour communiquer les remèdes au siège de la maladie.)*

Andrew J. Spinner, Indianapolis, Ind., U.S., 2nd June, 1887; 5 years.

Claim.—1st. The method herein described of impregnating the open air with impalpable powder permeated or charged with carbolic acid or other antiseptic remedy, which consists of first, dividing the powder infinitesimally, then liberating it by striking the receptacle slightly in proximity to the mouth or nostrils, whereby it can be inhaled or drawn in the manner set forth. 2nd. The method herein described of imparting antiseptic remedies to the system, which consists in impregnating a finely divided medium with the same, confining said medium in a receptacle of fine fabric, and liberating an impalpable portion of the antiseptic medium by striking the receptacle while in close proximity to the nostrils or mouth during inhalation, substantially as described.

No. 26,826. Portable Switch Table and Car Replacer.*(Plaque d'aiguillière et appareil pour remettre les chars sur la voie portatifs.)*

Arthur Durieu, New Orleans, La., U.S., 2nd June, 1887; 5 years.

Claim.—1st. In a car replacer and switch table, the combination, with a platform having a wing, of a V-shaped rib on the said platform, and a tongue pivoted on the platform and adapted to swing over the wing, substantially as herein shown and described. 2nd. The combination, with a platform having ribs on the upper surface, and a wing provided with side flanges, of a tongue pivoted on the platform and swinging over the wing, substantially as herein shown and described. 3rd. In a car replacer, a platform having a wing extending from its forward edge, parallel ribs on the upper face at or near its longitudinal side edges, and longitudinal flanges on the under face parallel with the upper ribs, and forming a separate rail receiving channel below each rib and in vertical alignment therewith, substantially as set forth. 4th. In a car replacer, a platform adapted to be secured upon and over either rail of a track, and having a wing parallel ribs on its upper side adapted to be brought into vertical alignment with either of the rails of a track, and notches in the platform between the forward ends of the parallel ribs, substantially as shown and described. 5th. A platform provided with a wing, ribs on the upper surface, ribs and flanges on the underside and screws in the said flanges, substantially as herein shown and described. 6th. The combination of the platform A having the plain wing B, parallel ribs E, E' on its upper surface, and parallel rail-receiving flanges on its underside, of the platform A₁ having the flanged wing B₁ M, the V-shaped rib on its upper surface, parallel rail-receiving flange on its lower face, and the horizontally swinging tongue pivoted at the angle of the V-shaped flange, the free end of said tongue being adapted to rest against either flange M, substantially as set forth.

No. 26,827. Apparatus for Varying the Velocity of Mechanism.*(Appareil pour varier la vitesse des machines.)*

William W. Beaumont, Herne Hill, Eng., 2nd June, 1887; 5 years.

Claim.—1st. In apparatus for varying the velocity of rotating mechanism, the cone A, having during the rotation with the spindle S, to which its small end is freely attached, always one part of its outer surface, parallel, or nearly so, to the axis of the spindle S, in combination with means for transmission of power by contact with any part of the said parallel part of the cone A, substantially as described and shown. 2nd. In apparatus for varying the velocity of rotating mechanism, the cone A, having during its rotation with the spindle S, to which its small end is freely attached, always one part of its outer surface parallel, or nearly so, to the axis of the spindle S, in combination with a friction wheel F, and with means for shifting the relative position of cone A and wheel F, substantially as described and shown. 3rd. In apparatus for varying the velocity of rotating mechanism, the cone A at the small end freely connected to and rotating with the spindle S, in combination with the wheel F and tooth wheel E, and the epicyclic gears B, A₁, C and D, substantially as described with reference to Figs. 5 and 6. 4th. In apparatus for varying the velocity of rotating mechanism, the cone A at the small end freely connected to and rotating with the spindle S having an eccentric G, in combination with the wheel F, tooth wheel E and the epicyclic gears B, A₁ and D, and in combination with the means described for shifting the relative position of the cone A and the wheel F, and for braking the latter, substantially as described with reference to Figs. 7, 8, 9 and 10. 5th. In apparatus for varying the velocity of rotating mechanism, the cone A at the small end freely connected to and rotating with the spindle S, in combination with the wheel F, means for shifting the relative position of the cone A and the wheel F, and with the bevel gears, substantially as described with reference to Fig. 11.

No. 26,828. Camp Hammock and Table.*(Hamac et table de camp.)*

Alfred Atkins and Allan R. Ritchie, Montreal, Que., 2nd June, 1887; 5 years.

Claims.—1st. A hammock, formed of slats of wood, or other suitable material suspended by the cords, substantially as described. 2nd. In a hammock, the transverse slats or ribs, with the side netting formed of cords a₁, a₂, b₁, c, c₁, substantially as described. 3rd. The lamp-table formed of slats of wood, or other suitable material, substantially as described. 4th. The compound hammock and table made of wooden slats or ribs, or other material, secured by interlaced webbing and cords, substantially as described.

No. 26,829. Wick Raising Mechanism for Lamps.*(Machine à Monter les mèches des lampes.)*

Wolcott A. Hill, New York, N.Y., U.S., 2nd June, 1887; 5 years.

Claim.—In an Argand burner, the combination of a ring or analogous device for attachment to a wick, of a vertically movable rod, a tongue on the one part and a slot or a loop on the other part, substantially as specified.

No. 26,830. Numbering, Printing, Cutting and Collecting Tickets, Cheques, Labels, or the Like, from a Continuous Web of Paper, Card-board, or the Like, and Apparatus and Mechanism Employed Therefor.*(Numérotage, impression, coupage et collection de billets, mandats, étiquettes, ou autres choses semblables, à même une bande continue de papier, carton, ou autre chose semblable, et appareil et machine pour cet objet.)*

John M. Black, London, Eng., 2nd June, 1887; 5 years.

Claim.—1st. In rotary printing machines, the general construction and arrangement of the improved numbering machine, such as is shown in Figs. 1, 2 and 3, which will print on a continuous running web of paper, cardboard, or the like, numbers of the same denomination with each revolution of the cylinder, which may be varied in quantity and subject matter, and sever such like printed quantities of one denomination from the continuous web, and deliver them, as severed in sheets, one on the other, in consecutive order, preparatory for being cut up into bundles of consecutively numbered tickets, substantially as and for the purpose hereinbefore set forth. 2nd. In numerical printing machines, the disposition, arrangement and actuation of a number of type-numbering heads, each arranged on separate axles and placed around the periphery of a cylinder, which will, with every revolution of such cylinder, print type numbers of a like denomination, in quantities according to the number of heads employed, the consecutive order of change to the type numbers being given with every complete revolution of such cylinder, substantially as shown at Figs. 5, 5a, 8 and 8a, and for the purpose hereinbefore set forth. 3rd. In instruments of numbering heads, designed whilst revolving, for giving their impressions in consecutive order on a running web of paper, cardboard, or the like, the construction of numbering disks having their actuating ratchets outside and combined with lock wheels, substantially as shown at Fig. 4a, and for the purposes hereinbefore set forth. 4th. In a rotary numerical printing machine, designed for printing tickets or the like on a running web, as shown at Figs. 1 and 2, the arrangement of rollers and endless tapes for receiving the lengths of printed consecutively numbered sheets, as they are severed from the continuous web, and placing such lengths one on the other in consecutive order

in a receiving-box, substantially as and for the purpose hereinbefore set forth. 5th. In a rotary numerical printing machine for printing numbers consecutively on a running web of paper, cardboard, or the like, the use of multi-numbering heads, so arranged and actuated that two or more of such numbering heads on one axle will, in conjunction with other similar numbering heads, supported on the periphery of a cylinder, deliver their numbers side by side in consecutive order at equal distances apart, substantially as and for the purpose hereinbefore set forth. 6th. In numbering heads designed for rotary numerical printing machines, the employment of discs, each having eleven faces, ten of which are provided with type numbers from 0 to 9, the remaining face of each disc being left blank, the said discs, when their supporting cylinder is revolving, being caused to deliver their numbers in consecutive order without any prefix of the cypher, substantially as and for the purpose hereinbefore set forth. 7th. In rotary numerical printing machines, designed for printing on a running web of paper, cardboard, or the like, the novel adaptation and combination with such machine, of the cylinder *h*, when employed for printing alphabetical letters, or alphabetical letters, and numbers in series as shown at Figs 6 and 6a, substantially as and for the purpose hereinbefore set forth.

No. 26,831. Tub. (*Cuvette*.)

David Blouin, South Durham, Que., 2nd June, 1887; 5 years.

Reclame.—La combinaison des pièces A, A, du fond B avec la projection D, du cercle C, et des pièces E, E, le tout tel que ci-dessus décrit et pour les fins indiquées.

No. 26,832. Hinge for Cake Griddles.

(*Charnière pour moules à gâteaux.*)

Francis M. Van Etten, Chicago, Ill., U.S., 2nd June, 1887; 5 years.

Claim.—A hinge, with a T-shaped projection, having a groove in the centre of the same, a projection provided with two or more perforated bars, and a notch or groove corresponding to the groove in the T projection and the wire or pin forming the lock or fastening, substantially as described and shown.

No. 26,833. Head Rest. (*Appui-tête*.)

Jesse Smith, Toronto, Ont., 3rd June, 1887; 5 years.

Claim.—1st. A head rest, designed substantially as described, by which the shoulders may be made to support the weight of the head of the party using the said head-rest, substantially as and for the purpose specified. 2nd. The standards A connected together by the cross-piece B and D and fabric C, in combination with the cords F and G, arranged substantially as and for the purpose specified.

No. 26,834. Garment Supporter. (*Bretelles*.)

Reuben H. Sink, Grass Valley, Cal., U.S., 3rd June, 1887; 5 years.

Claim.—As an improved article of manufacture, the herein described garment supporter, comprising the yielding sides *b*, *b*, formed of a single piece of sheet metal, one of the sides having an integral eye at its lower end, and the integral keepers *d*, *e*, near its upper end and on opposite sides, as described, and the other side having the inclined retaining points or teeth *b*₄, formed integral with it and the pins connected at their lower ends by a cross-bar which is swivelled in the eye and having their free ends adapted to enter the keepers, substantially as described for the purpose set forth.

No. 26,835. Running Gear for Road Wagons. (*Train de wagon routier*.)

Cyrus W. Saladee, Cleveland, Ohio, U.S., 3rd June, 1887; 5 years.

Claim.—1st. A flexion spring for road wagons, consisting of two or more plates wherein the "back" or main plate is thinner than the overlying plate or plates, substantially as and for the purpose set forth. 2nd. A duplex spring for side-bar, road wagons, consisting of two similar flexion members, arranged in pairs under each end of the body, the upper plates of each member being extended in a straight line from the elevated centre portion of the spring in opposite directions, to form a support for the body and the outer end of the spring suspended from the side bars on opposite sides, substantially as set forth. 3rd. A flexion spring for road wagons, consisting of a main plate A, suspended from pivotal bearings at each end, and having the top or overlying plates B, C, extended to form a support for the body, substantially as set forth. 4th. In a road wagon, the combination, with the axle duplex springs arranged parallel to and on opposite sides of the same, each rising in the centre and connected at the ends to bearings arranged transversely to and extended from opposite sides of the axle, the upper plates of each spring being extended in opposite directions to form the arms D for the support of the body, substantially as set forth. 5th. In a road wagon, a fifth wheel coupling, consisting of the two plates D, D, centre bearing E₂, in combination with the raised frictional bearings C, C, extended from the outer ends of the plates towards the centre thereof, substantially as and for the purpose set forth.

No. 26,836. Thrashing Machine.

(*Machine à battre*.)

Frank Eves, Massillon, Ohio, U.S., 3rd June, 1887; 5 years.

Claim.—1st. The combination, in a machine of the class described, with means for carrying the straw, of a straw distributor consisting of a shaft arranged diagonally across the line of travel of the straw, and provided with a series of distributing arms, and means for rotating said shaft, as and for the purpose set forth. 2nd. The combination, in a machine of the class described, with the cylinder and concave and straw-carrying platform, of a straw distributor consisting of a revolving shaft arranged diagonally across said platform, and provided with a series of distributing arms, as and for the purpose set forth. 3rd. The combination, in a machine of the class described, with the straw carrier of the straw distributors G, G, each

consisting of a revolving shaft arranged diagonally across the straw carriers and provided with a series of distributing arms, as and for the purpose set forth. 4th. The combination, in a thrashing machine with the platform D, of the straw distributors G, G, arranged diagonally across said platform, and provided with a series of distributing arms, means for moving the platform and means for rotating the distributors, as and for the purpose set forth. 5th. In a grain separator, the platform D sloping from centre towards the sides, and provided with the diagonally placed notched bars D₁, as and for the purpose set forth. 6th. The combination, with the platform D, having projecting rods *d*, *d* in the rear end thereof, and means, as described, for longitudinally and vertically moving the platform, of the shaft H having arms *h* passing between the rods *d*, *d*, and means for rotating shaft H, whereby the straw is taken from the rods *d*, *d*, and carried over the shaft H, substantially as described. 7th. The combination, with the platform D, having rods *d*, *d*, and the shaft H having arms *h*, *h*, said shaft being arranged as described, of the grain board K, the spiral conveyers *l*, *l* and the screen M, said board K and conveyers *l* being located beneath shaft H, substantially as described. 8th. The combination, with the shaft E, having oppositely set cranks E₁, E₂, of the platform D and separator I, each having one end mounted on said cranks, and their opposite ends mounted on revolving cranks of equal throw, as and for the purpose set forth. 9th. The combination, in a machine of the class described, with a shaft having oppositely set cranks, of a straw-carrying platform having one end mounted on two of said cranks, and its other end mounted on revolving cranks of equal throw, and a screen having one end mounted on the opposite crank of said shaft, and its other end mounted on revolving cranks of equal throw, all substantially as described. 10th. The combination of the platform D, having rods *d*, the double crank shaft E, the screw L and the shaft H having arms *h*, as and for the purpose set forth. 11th. In a thrashing machine, the straw belt O consisting of ropes O₁, bars O₂, clasps O₃ and screws O₄, as and for the purpose set forth. 12th. The combination, with the frame A and the forward wheel of a thrashing machine, of the screw Q mounted in said frame with its point directly over the top of said wheel, as and for the purpose set forth. 13th. The screen M, comprising the series of bars, upwardly inclined tapering recesses between them, and the series of cross wires secured by staples to the tops of said bars, as and for the purpose set forth. 14th. The combination, in a machine of the class described, of a vibrating separator having an upward and outward movement and a downward and inward movement, and a stationary return board L, so adapted, that the said separator in its downward and inward movement may move the grain inward to a point at which it may pass over the end of the board to the screen, substantially as set forth. 15th. The combination, with a thrashing cylinder, of a feed board D, having rounded corners *b*₃, substantially as shown and described and for the purpose set forth.

No. 26,837. Gas Stove. (*Poêle à Gaz*.)

John Laxton, Toronto, Ont., 3rd June, 1887; 5 years.

Claim.—1st. An oven B, having a perforated gas pipe located near its top, in combination with the passageways J, arranged to connect the oven B with the oven A, substantially as and for the purpose specified. 2nd. The ovens A and B connected together by the passageways J, in combination with the deflecting plate D located at the top of the oven B in proximity to a perforated gas pipe, substantially as and for the purpose specified. 3rd. The oven B heated by gas jets, as described, and having an air-space L formed around its exterior, in combination with the water pipes M arranged within the space L, substantially as and for the purpose specified. 4th. The oven B heated by gas jets as described, and having an air-space L formed around its exterior in combination with the pipes M and deflecting plates O, substantially as and for the purpose specified. 5th. The oven B heated by gas jets as described, and having an air-space L formed around its exterior, in combination with the water pipes M and perforated gas pipe N arranged within the space L, substantially as and for the purpose specified. 6th. The oven B heated by gas jets as described, and having an air-space L formed around its exterior, in combination with the water pipes M, perforated gas pipe N, and deflecting plates O arranged within the space L, substantially as and for the purpose specified.

No. 26,838. Straight-Way Valve.

(*Soupape oscillante*.)

Edmund Lunkenheimer, Cincinnati, Ohio, U.S., 3rd June, 1887; 5 years.

Claim.—1st. The combination, in a straight-way valve, of a vibrating carrier having a loosely coupled valve applied to its free end, said carrier being adapted to impinge against a wedge or bevelled bearing and, thereby, force said valve to its seat with a positive closing movement, substantially as described. 2nd. The combination, in a straight-way valve, of a vibrating carrier having a loosely coupled adjustable valve applied to its free end, said carrier being adapted to impinge against a wedge or bevelled bearing, and, whereby, force said valve to its seat with a positive closing movement, substantially as described. 3rd. The combination, in a straight-way valve, of pipe connections B, B₁, in line with each other, a rock-shaft parallel with the axis of said connection, and a vibrating carrier secured to said shaft, the free end of said carrier being provided with a pair of valves that close against inclined seats, at the inner ends of said connections, substantially as described. 4th. In a straight-way valve, the main chamber A and removable cap D, in combination with the rock-shaft F, vibrating carrier M, loosely-coupled valve N, bevelled shoulder S and a wedge or inclined projection T, for the purpose described. 5th. The combination, in a straight-way valve, of vibrating carrier M, loosely coupled valve N, and adjusting screw R, for the purpose described. 6th. The combination, in a straight-way valve, of a vibrating carrier having a loosely coupled valve applied to its free end, said carrier being provided with a stop that prevents the open valve coming in contact with the interior of the shell, substantially as described. 7th. The combination, with a valve and its seat, of a rib extending diametrically across and con-

necting opposite sides of the seat, and with its lower edge in the same plane therewith, whereby tilting of the valve is prevented, substantially as described. 8th. A valve shell consisting of the main chamber A provided with pipe connections B, B', in line with each other, a neck C projecting laterally from said chamber, and a tubular portion E located between said chamber and neck and having its axis parallel with the axis of said pipe-connections, these parts A, B, B', C and E being integral, as herein described. 9th. A shell provided with a rib, the bearing surface of which is in the same plane as the seat against which the valve closes, whereby tilting of the latter is prevented, substantially as described.

No. 26,839. Coin Pad for use on Counters, Glass Cases, etc. (*Bourrelet à monnaie pour comptoirs, montres, etc.*)

Flavius J. Allen and William J. Cahoon, New York, N. Y., (assignees of Mark J. Kraus, San Francisco, Cal.), U. S., 3rd June, 1887; 5 years.

Claim.—1st. As a new article of manufacture, a coin pad provided with a series of elastic prongs or points projecting vertically from the surface thereof, substantially as and for the purpose set forth. 2nd. A coin pad, the body of which is made of an elastic or flexible material provided with a series of elastic or flexible prongs or points, projecting vertically from the surface thereof, and made integral with the same, substantially as and for the purpose set forth. 3rd. A flexible or elastic coin pad formed on its upper surface with integral projections and provided with a backing, substantially as and for the purpose set forth.

No. 26,840. Paper Pulp Screen.

(*Tamis à pâte à papier.*)

The Seneca Screen Company, Penn Yan, N. Y., U. S., (assignee of Calvin Russell and Patrick H. Cragin), 3rd June, 1887; 5 years.

Claim.—1st. In combination with the screen, subjacent pulp-vat and rocking pumping bars in said vat, a barrier projecting from the underside of the screen toward the top of the pumping bar, to check the flow of pulp across the top of the pumping bar, as set forth. 2nd. In combination with the screen, subjacent pulp-vat and rocking pumping bar in said vat ribs, on top of the pumping bar, and a barrier projecting from the underside of the screen intermediate the aforesaid ribs, substantially as set forth. 3rd. In combination with the screen and subjacent pulp-vat, the pumping bar pivoted at the centre of its top, substantially as shown and described. 4th. In combination with the screen and subjacent pulp-vat, the pumping bar pivoted at the centre of its top, and stationary bars at the sides of said pumping bar, as shown and set forth. 5th. In combination with the screen and subjacent pulp-vat, the pumping bar pivoted at the centre of the top, stationary bars at opposite sides of said pumping bar, and a barrier between the screen and pumping bar at the centre of the latter, substantially as described. 6th. In combination with the screen and subjacent pulp-vat, the pumping bar having its top inclining from the longitudinal central line toward opposite sides, substantially as described and shown. 7th. In combination with the screen and subjacent pulp-vat, the pumping bar having its top inclining from the longitudinal central line toward opposite sides, and the longitudinal side edges of the top curved upward, substantially described and shown. 8th. In combination with the screen and subjacent pulp-vat, the pumping bar having its top inclining from the longitudinal central line toward opposite sides and ribs projecting from the top of the pumping bar, as shown. 9th. In combination with the screen and subjacent pulp-vat, the pumping bar having its top inclining from the longitudinal central line toward opposite sides, and the longitudinal side edges of the top curved upward, and ribs projecting from the top of the pumping bar, substantially as described and shown. 10th. In combination with the screen and subjacent pulp-vat, the pumping bar pivoted at its top and having the longitudinal side edges of the top curved upward, as set forth and shown. 11th. In combination with the screen and subjacent pulp-vat, the pumping bar pivoted at its top, and having the top inclining from the pivoted line of the bar toward the sides thereof, as set forth. 12th. In combination with the screen and subjacent pulp-vat, the pumping bar pivoted at the centre of its top and having the top inclining from the longitudinal central line toward opposite sides, and the longitudinal side edges of the top curved upward, as set forth and shown. 13th. In combination with the screen and subjacent pulp-vat, the pumping bar pivoted at the centre of its top and the longitudinal side edges of the top curved upward, and ribs projecting from the top of the pumping bar, as described and shown. 14th. In combination with the screen and subjacent pulp-vat, the pumping bar pivoted at the centre of its top, and having its top inclining from the longitudinal central line toward opposite sides of the bar, and ribs projecting from the top of the pumping bar, as shown and set forth. 15th. In combination with the screen and subjacent pulp-vat, the pumping bar pivoted at the centre of its top, and having its top inclining from the longitudinal central line toward opposite sides, and the longitudinal side edges of the top curved upward, and a barrier interposed between the screen and pumping bar along the longitudinal central line of the top of the latter, substantially as shown and set forth. 16th. In combination, with the screen and subjacent pulp-vat, the pumping bar pivoted at the centre of its top, and having the top inclining from the longitudinal central line toward opposite sides of the bar, and the longitudinal side edges of the top of the pumping bar curved upward, a barrier interposed between the screen and pumping bar along the longitudinal central line of the latter, and ribs projecting from the top of the bar, all constructed and combined substantially as described and shown.

No. 26,841. Combined Plug and Cock for Barrels, etc. (*Bondon et robinet combinés pour barils, etc.*)

Charles C. Limirdoll and John H. McMahon, Fort Edward, N. Y., U. S., 3rd June, 1887; 5 years.

Claim.—1st. A plug A, provided with a valve B having a tubular perforated stem, a perforated chamber C holding a spring D pressing the valve B upon its seat and making a tight joint, a sleeve E having milled rim E and screwed end e adapted to couple with the plug A, said sleeve holding rotatively a tube or spout F projecting at the coupling end so as to push the valve B off its seat and form a continuous passage with the valve stem b, substantially as set forth. 2nd. The combination of the plug A, notched flange A', threaded chamber A'', valve seat a'', perforated chamber C, spring D, valve B having perforated tubular stem b, sleeve E, head E', threaded end e, spout or tube F held rotatively in said sleeve, and washer F', substantially as set forth. 3rd. The combination of the plug A, thread a', rim A', notches a', nipple A'', valve seat a'', chamber A'', thread a'', valve B, tubular stem b, perforations b', flaring end b'', cap C, and spring D, substantially as set forth. 4th. The combination of the sleeves E, rim E, nipple e, tube F, collar f, washer F', set-screw F', and groove f', substantially as set forth.

No. 26,842. Steam Trap or apparatus for Separating Water, etc., from Steam, Vapour or Gases. (*Trappe de vapeur ou appareil pour séparer l'eau, etc., des vapeurs et des gaz.*)

Isaac S. McDougall, Irk Vale, Thomas Sugden, Oldham, and James T. McDougall, London, Eng., 3rd June, 1887; 5 years.

Claim.—1st. In apparatus for the purposes described, the combination of a vessel or casing, and a float and weight, or their equivalents, enclosed therein, with an outlet valve, substantially as hereinbefore described. 2nd. In apparatus for the purpose described, the testing rod G, arranged and operated substantially as hereinbefore described. 3rd. The combination, in a steam trap, of a lever mounted on a fulcrum pin a', carrying on its ends a float C and a weight D, and operating a stop valve with inlet and outlet pipes A', A', as described.

No. 26,843. Extracting Gold and other Precious Metals from their Ores, and apparatus therefor. (*Extraction de l'or et autres métaux précieux de leurs minerais et appareil pour cet objet.*)

Max W. Weber, (assignee of Ewald Fischer), London, Eng., 3rd June, 1887; 5 years.

Claim.—1st. The improved method of extracting gold and other precious metals from their ores herein above described, wherein:—Firstly, the ores ground as finely as possible and mixed with from 6 to 8 times their volume of water, with or without an addition of common salt or of another chloride or bromide preparation, or of common salt and permanganate of potass, or of common salt and acid, are placed in a vat, the interior of which is lined with an amalgamated metal, which is electrically connected to a negative electrode, and the bottom of which is covered with a layer of mercury which is electrically connected with the amalgamated metal, the said vat containing a stirring apparatus, the shovels of which consist also of an amalgamated metal which is electrically connected with the negative electrode, so that by the motion of the stirring apparatus the ores and water are continuously maintained in a uniform mixture, and the pure metal is separated on the cathode while on the anode, the corresponding acid or the halogen is set free, and secondly, when all the reduced metal has been taken up by the mercury, the whole mass is discharged into an iron trough, which is provided with a series of horizontal rollers rotating at different speeds, these rollers carrying carbon or metal bars which represent the anodes, while the mercury and the iron trough represent the cathode, so that the fine amalgam particles produced in the vat and still mixed with sand are condensed in the mercury while the tailings which are free from metal are drawn off, substantially as hereinbefore described. 2nd. The herein-described construction of apparatus for extracting precious metal from their ores, consisting of a vat A having a lining of amalgamated plates of copper or other suitable metal, to be connected with the negative electrode of an electrical generator, and having a stirring apparatus a, b to be connected with the positive electrode of the electrical generator, and having a cock c for discharging its contents, such vat operating in combination with an iron trough or vessel B containing revolving wood rollers having copper coils, and carbon or metal rods at their ends, such rollers being electrically connected with the positive electrode of an electrical generator while the trough is connected to the negative electrode.

No. 26,844. Edging Machine.

(*Machine à enlever les flaches.*)

Peter Payette, Pentanguishene, Ont., 4th June, 1887; 5 years.

Claim.—1st. In an edger, the combination of the friction drum E on the shaft C, which has bearings on the frame T, and which is driven by pulleys and belting connected with the mandrel B, and the friction wheel H on the shaft G, which has an eccentric bearing f actuated by the arm F, which is pivotally attached to the lever arm P, and adapted to move the friction wheel H into and out of gear with the friction drum E, and from and against the brake H, substantially as described. 2nd. In an edger, the combination of the guide-bars c and d bolted to the frame T, and the cross-head O, which is pivotally connected to one end of the arm g, the other end of said arm g being pivotally attached to the end of the pivoted lever-arm P, the shifter-arm Q which is rigidly attached to the cross-head, and which contains an oil-case, the end of which clutches the connecting collar

n between the adjustable saw collars r , so as to shift the position of the adjustable saw collars r on the mandrel B when motion is given to the cross-head, substantially as specified. 3rd. The combination of a press roller attached to a frame which is pivoted to the main frame, and the springs S which are bolted to the top of said main frame, the ends thereof being free, the ends of said roller being adapted to rest on said springs near the free ends, substantially as specified. 4th. The combination of the guard X, pivoted to the main frame, and having curved fingers Y which rest between the wheels on the rear press roller R₁, substantially as described and for the purpose specified. 5th. In an edger, the frame T cast in one piece, and having the upper portion T₁ in the form of a circle, at the centre of which the mandrel B has bearings, in combination with the movable bearing-piece N having arms which radiate from the said centre and bolted to the frame, substantially as specified. 6th. In an edger, the extension-piece A, which affords bearings for the friction-drum shaft C, and mandrel B, in combination with the main T of the machine to which said extension-piece is rigidly secured, substantially as described. 7th. The frame T, which affords bearings for shafts which carry the pulleys I, K, K₁, in combination with the straight belt i , which is driven by motion communicated from the friction-wheel shaft G, substantially as specified. 8th. The frame T, which affords bearings for shafts which carry the pulleys I, K, K₁ and L, and the roller L, in combination with the straight belt i which is driven by friction-wheel shaft G, substantially as described and for the purpose specified. 9th. The combination of the mandrel B, the removable bearing-piece N bolted to the main frame, the fixed saw collars s and loose collars t , substantially as described and for the purpose specified.

No. 26,845. Process of Moulding Articles of Fibrous Ware. (*Procédé de moulage des objets de matières fibreuses.*)

Henry Carmichael, Boston, Mass, U.S., 4th June, 1887: 5 years.

Claim.—1st. The improvement in the art of moulding articles of pulp, which consists in thoroughly drying the same in the press in which they are formed by means of a current of air. 2nd. The process of forming hollow ware from pulp, which consists in first subjecting the pulp to pressure between a flexible diaphragm and a perforated mould, and then forcing hot or cold air through the moulded article while in the press, substantially as described. 3rd. The improved apparatus for moulding articles from pulp, which consists of a compressing chamber provided with a perforated mould, and pulp and air connections, and a perforated diaphragm, as and for the purposes described. 4th. In an apparatus for moulding articles of pulp, the combination, with a pulp chamber provided with a pulp port and perforated cover, and a hood connecting with a source of air supply, of a plunger having a perforated mould plate corresponding to the shape of said cover and means for forcibly raising the plunger and expelling the moisture from the pulp, as described. 5th. In combination with a pulp chamber having a plunger, a pulp port, a perforated cover and a hood having a discharge orifice, and connected with a source of air supply, a plate within the hood mounted upon a suitable stem, substantially as described. 6th. As an article of manufacture, the article made of pulped fibre, by the operation of compressing the watery pulp against a perforated mould, and subsequently expelling the moisture from the same while still in the mould by subjecting it to the action of hot or cold compressed air.

No. 26,846. Ice Creeper. (*Crampon à glace.*)

John G. Skinner, Oswego, N.Y., U.S., 4th June, 1887: 5 years.

Claim.—1st. In an ice-creeper, a fastening-plate and an upwardly-bent and forwardly extending spring, both formed from a single blank, in combination with a heel-plate, one end of which is journalled in bearings on the fastening plate and rests under the spring, substantially as described. 2nd. In an ice-creeper, a fastening-plate and an upwardly-bent and forwardly extending spring, both formed from a single blank of the shape shown, the ends of the narrow side strips of the blank being bent into ring-shape to form bearings on the fastening-plate, in combination with a spurred heel-plate, one end of which is journalled in said bearings and rests under the spring, substantially as described.

No. 26,847. Construction of Tunnels, Subways, or Arches. (*Construction de tunnels, voies souterraines ou arches.*)

Charles C. Gillman, Eldora, Iowa, U.S., 4th June, 1887: 5 years.

Claim.—1st. A subway, arch, tunnel, or similar structure, provided with a layer of porous earthenware, coated or saturated with asphalt, substantially as described. 2nd. A subway, tunnel, arch, or similar structure, the inner surface of which consists of, or is lined with porous earthenware coated or saturated with asphalt, substantially as described. 3rd. A subway, tunnel, arch, or similar structure, having an inner surface or lining formed of blocks of porous earthenware, coated or saturated with asphalt, and bonded together with the same material, substantially as described.

No. 26,848. Electric Signalling Apparatus. (*Appareil électrique à signaux.*)

Walter J. Dudley, Everett, Mass., U.S., 4th June, 1887: 5 years.

Claim.—1st. A signal controlling instrument comprising a neutral electro-magnet and actuating armature and retractor therefor, a step by step device actuated by the said armature governing the operation of the signalling instrument, a stop member connected with the said step by step device, and a co-operating stop member, and neutral armature connected therewith, and retractor for the latter armature adjusted to cause the said armature to be attracted by the impulses that move the actuating armature, and to be held by residual magnetism between said impulses in position to engage the stop members, and to be retracted when the magnet is affected by currents of alternating polarity into position to disengage the stop

members, substantially as described. 2nd. The combination of a step by step device, and neutral electro-magnet and actuating armature and retractor therefor, with a stop member carried by the said step by step device, a co-operating stop member and controlling armature therefor held by residual magnetism in position to engage the other member and arrest the step by step device at the union point while the actuating armature is being operated, a signalling instrument operated by currents of alternating polarity and shunt therefor, a circuit controlling device in said shunt operated by the step by step device to open the said shunt at one stop in its movement, a telephone and shunt circuit therefor, and a circuit controlling device in said shunt circuit operated by the step by step device being opened when the said device is arrested at the union point, and also when the shunt of the signalling instrument is opened, substantially as described. 3rd. The combination of the step by step device, and electro-magnet and actuating armature and retractor therefor, with telephonic instrument connected with the circuit of the said magnet, and a shunt for said instruments and armature operated by said magnet controlling the said shunt, which is closed by the said armature at each impulse that operates the step by step actuating armature, substantially as described. 4th. A step by step device provided with a stop member, and with devices controlling the circuit of a telephone and signalling instrument, combined with the telephone supporting switch, and a stop member controlled thereby being placed by the said supporting switch when the telephone is removed therefrom in position to engage the stop member of the step by step device, and arrest the said device in position to place the telephone in circuit, substantially as described.

No. 26,849. Window Curtain and Mosquito Bar Combined. (*Rideau de fenêtre et moustiquaire combinés.*)

Charles Darland, Dryden, Mich., U.S., 4th June, 1887: 5 years.

Claim.—1st. The combination, with double window shades suspended from a common support, of a weighted free mosquito-bar affixed at its upper end to said support and hanging behind curtains, the shades and net forming one device, for the purposes set forth. 2nd. In a curtain-fixture, the weighted mosquito-bar A suspended from slit D, in combination with the window shades B and C, the former attached to said slit D, and the latter to slit E by straps F, each shade being operated independently by cords and pulleys, said cords being secured to the centre screw-ring f on the supporting slats, thence passed through the screw-rings f , being looped around the roller at the lower end of the shade, and finally secured to the supporting-slat of the shade, as described and shown.

No. 26,850. Fifth-Wheel. (*Rond d'avant-train.*)

William W. Grier, Hulton, Penn., U.S., 4th June, 1887: 5 years.

Claim.—1st. In a fifth wheel for vehicles, the combination, with the circle plates, of a brace R R, one arm of which is back of the axle and constitutes the king-bolt, while the other arm extends forward under the axle and is attached to the circle plate, substantially as and for the purposes described. 2nd. In a fifth wheel for vehicles, the combination, with the circle plates, of an U-shaped brace R R, one arm of which is back of the axle and constitutes the king-bolt, and the other arm of which extends to the upper circle plate and nuts T, T, arranged on the upper ends of the arm, substantially as and for the purposes described. 3rd. In a fifth wheel for vehicles, the combination, with the circle plates, of the U-shaped brace R R, and the hanger L arranged on the R back of the axle, substantially as and for the purposes described. 4th. In a fifth wheel for vehicles, the combination, with the circle plates, of the U-shaped brace R R, the hanger L arranged on the arm R back of the axle, and the anti-rattling plug V interposed between the socket of the hanger and the arm, substantially as and for the purposes described. 5th. The combination of a fifth wheel, a king-bolt back of the axle, a reach and a hanger mounted on the king-bolt, said hanger being attached to the reach and forming the sole support for the front end thereof, substantially as and for the purposes described. 6th. The combination, with a fifth wheel, of a king-bolt back of the axle, collars encircling the king-bolt, and a hanger socket L₁ mounted on the king-bolt and fitting around the same inside the said collars, substantially as and for the purposes described. 7th. The combination, with a fifth wheel, of a king-bolt back of the axle, collars encircling the king-bolt, and a hanger socket L₁ mounted on the king-bolt and fitting around the same inside the said collars, and secured to the collar of the upper circle plate so as to be prevented from rotation independently thereof, substantially as and for the purposes described. 8th. The combination, with the king-bolt back of the axle and the circle plates, of a brace extending from the king-bolt to the upper circle plate, and a shoe S fitting around the brace and projecting therefrom under the lower circle plate, substantially as and for the purposes described.

No. 26,851. Lamp Attachment.

(*Disposition aux lampes.*)

Charles Long, Toronto, Ont., 4th June, 1887: 5 years.

Claim.—In a lamp attachment for heating purposes composed of wire, the combination of the rim A, arms B, B, the rods C, C, constructed substantially as and for the purposes set forth.

No. 26,852. Hospital Bedstead Attachment.

(*Disposition aux lits d'hôpitaux.*)

Caroline Daake, Avon, Ill., U.S., 4th June, 1887: 5 years.

Claim.—1st. The combination, with the frame C, of the head sections C₁, C₂ of the sheet, said sections being detachable from the frame and from each other, and having respectively eyes p , p , and stiffening rods p , p , the hooked operating cord M₂, the turn-shaft and the standards for supporting the turn-shaft, whereby said head-sections may be raised singly or together, independently of the frame, as set forth. 2nd. The combination, with a bed, of a frame

C hinged together at the sides and ends, as shown, and provided with hinge locks β and eye-bolts α , α , removably attached sheet B having a foot section and two head sections, the latter adapted to be united or separated, and having respectively eyes p and stiffening rods p_1 , the hooked operating cords and the turn-shaft, whereby the head-sections of the sheet may be lifted singly or together independently of the frame, or by properly locking or unlocking the hinges, the whole sheet either longitudinal half, or the foot-section may be raised in connection with the frame, as set forth. 3rd. The sheet B, composed of sections c , rubber portions s and sections c_1 , c_2 , the latter detachable from the frame, and each other, and having eyes p and stiffening-rods p_1 , combined with the lock-hinged frame C having screw eyes α , the hooked cords m_2 , m_3 , the longitudinally extensible shaft, having a turn-wheel pulley, a ratchet and pawl, the tripods h , h and the vertically extensible standards D, D¹ braced by the said tripods h , h , as set forth.

No. 26,853. Knife Sharpener.

(*Rémouleur de couteaux.*)

Frank J. Reinhold, Detroit, Mich., U.S., 4th June, 1887; 5 years.

Claim.—1st. In a knife sharpener, the combination, with an inclosing case of sharpening rollers mounted therein, one or more of said rollers having a yielding engagement in the case, substantially as described. 2nd. In a knife sharpener, the combination, with a case, of sharpening rollers, having a lateral yielding engagement therewith, and a spring acting upon said rollers to restore them to normal position and cause the rotation of said rolls, substantially as described. 3rd. The combination, with a case, of sharpening rollers provided with elongated bearings and springs acting upon said rollers, the construction being such that when the blade is engaged with the rollers, they may yield to a limited extent, and be restored to normal position when the blade is removed, said rollers being partially rotated by said operation, substantially as described. 4th. The combination, with a case, of sharpening rollers having a yielding engagement therewith, and friction-rolls E, E¹ engaged therewith, substantially as and for the purpose described. 5th. The combination, with a case, of sharpening rollers having a yielding engagement therewith, friction-rolls E, E¹, located adjacent to said sharpening rollers, and springs acting upon said sharpening rollers, substantially as and for the purpose described.

No. 26,854. Manufacture of Trunks, etc., from Chemically Treated Fibre.

(*Fabrication des coffres, etc., de fibres traitées par un procédé chimique.*)

Henry W. Morrow, Wilmington, Del., U.S., 4th June, 1887; 5 years.

Claim.—1st. The mode herein described of making from chemically-treated fibrous material a shell for the body and lid of a trunk or like article, said mode consisting in first making a tube of said material, then applying this tube to a former of the proper shape for the body and lid, then shrinking the tube upon said former, then removing the latter, inserting and securing the end pieces of the trunk and finally severing the shell into body and lid portions, all substantially as specified. 2nd. The mode herein described, of making from chemically-treated fibrous material a trunk or like article, said mode consisting in first making a tube of said material, then shrinking this tube over a former to produce a shell of proper shape for the body and lid, then removing the former and severing the shell, and finally securing said pieces to the body and lid portions of the shell, all substantially as specified. 3rd. The mode described of making from chemically-treated fibrous material a lined shell for a trunk or like article, said mode consisting in first making a tube of said material, and then shrinking said tube over a box which is to form the lining, all substantially as specified. 4th. A trunk body, composed of chemically-treated fibrous material, and having end pieces with flanges along the bottom and sides, and a central portion constituting in one piece the bottom and sides of the body, and having end flanges also extending along the bottom and sides and overlapping the end pieces, all substantially as specified. 5th. A trunk lid of chemically-treated fibrous material, having end pieces with flanges along the top and sides, and a central portion constituting in one piece the top and sides of the lid, and having end flanges also extending along the top and sides and overlapping the end pieces, all substantially as specified.

No. 26,855. Horse Hay Rake.

(*Râteau à cheval.*)

George K. Schauer and Christian A. Herr, Osborn, Ohio, U. S., 4th June, 1887; 5 years.

Claim.—1st. A vehicle rake, having the wheels loosely mounted on the hollow iron axle, the tines secured on the axle, a frame with revolving carrying rollers fixed on one wheel, and a lever pivoted on a fixed piece of the axle, and provided with a cam projection, and operating mechanism whereby said cam is thrown into and out of the path of said rollers, all combined substantially as herein shown and described. 2nd. In a rake, the combination, with an axle or shaft on which tines are secured, of wheels mounted loosely on the ends of the axle, a frame on the hub of one wheel, which frame carries rollers, a disk secured on the axle adjacent to said frame, a lever pivoted on said disk and a spring for pressing the lever from the disk, and operating mechanism for holding said lever against the spring out of the path of said rollers, substantially as herein shown and described. 3rd. In a rake, the combination, with an axle on which tines are secured, of wheels mounted loosely on the ends of the axle, a frame on the hub of one of the wheels, and carrying rollers, a disk on the axle, a lever pivoted on the disk, a spring for pressing the lever from the disk in different positions, substantially as herein shown and described. 4th. In a rake, the combination, with an axle on which tines are secured, of wheels mounted loosely on the axle, the frame E on one wheel, the rollers E² on the frame, the disk F on the axle, the lever J pivoted on the same, a spring for pressing the

lever from the disk, and of the pivoted arm N provided with the lug O, substantially as herein shown and described. 5th. In a rake, the combination, with an axle on which tines are secured, of wheels mounted loosely on said axle, a frame on the hub of one of the wheels, rollers on said frame, a disk fixed on the axle, a lever provided with a cam projection pivoted on the disk, a spring for pressing the lever from the disk, and of a pivoted arm for locking said lever in place, substantially as herein shown and described. 6th. In a rake, the combination, with the axle carrying tines, of wheels mounted loosely on the axle, a frame on one wheel, rollers on the frame, a disk on the axle, the lever J pivoted on the disk and provided with a cam projection, the arm N for locking the lever J in place, and of a crank-shaft on the frame of the rake connected with the arm N, and provided with devices for operating it, substantially as herein shown and described.

No. 26,856. Paper Bag. (*Sac de papier.*)

Kilgour Bros., Toronto, Ont. (assignees of William H. Honiss, Hartford, Conn., U.S.), 4th June, 1887; 5 years.

Claim.—A paper bag, the square bottom of which has the flaps M and O folded down upon the middle quadrangular portion of the diamond L, and in which the two side folds of that diamond lap over each other entirely across that middle quadrangular portion, and in which one of the flaps O and M has the recess cut away from the inner thickness thereof, and which bag has the thumb-lip I made from the paper cut away from another paper bag to form a recess P therein, all substantially as shown and described.

No. 26,857. Flower Pot. (*Pot à fleurs.*)

Sarah L. Hunter and Aaron Bales, Little Rock, Ks., U. S., 4th June, 1887; 5 years.

Claim.—A flower-pot, formed of the outer sheet metal vessel a , having a spout F and apertures f and G near its upper edge, and the inner smaller vessel a' flared outwardly at its lower end, and there secured to the inner surface of the outer vessel and the outward and downward bent flange a_3 around the upper edge of said inner vessel, overlapping and secured to the upper edge of the outer vessel, the lower part of the inner vessel having apertures C communicating with the water space B formed between the said vessels, substantially as set forth.

No. 26,858. Grain Binder. (*Lieuse à grains.*)

The Noxon Bros. Manufacturing Company, Ingersoll, Ont. (assignee of John F. Seiberling, Akron, Ohio, U. S.), 4th June, 1887; 5 years.

Claim.—1st. The combination, with the cam wheel, of the knotted shaft crossing the plane of the knotted-actuating shaft and the face of said wheel, and inclined laterally in relation to and actuated by the latter, and the needle arranged to pass between said knotted-shaft and the cam-wheel, substantially as described. 2nd. The spiral segmental gear on the cam-wheel, in combination with the knotted-shaft, crossing the plane of the cam-wheel shaft and inclined laterally to the face of the cam-wheel, and having its actuating pinion located on one side of said cam-wheel shaft and the knotted on the opposite side thereof, substantially as and for the purpose described. 3rd. The combination, with the cam wheel and the shaft supporting and actuating it, of the knotted-shaft having its actuating-pinion on one end and the knotted-hook on the other, and arranged in close proximity to and crossing the plane of the cam-wheel shaft in laterally-inclined relation to the face of the cam-wheel and the spiral segmental gear on the cam-wheel for actuating said knotted-shaft, substantially as described. 4th. The jointed knotted-shaft, in combination with the vibrating hinged arm or frame E, carrying the swinging end or part of said shaft, a cam for opening the knotted-jaw, and a knife for severing the cord, and mechanism, substantially as described, for vibrating said arm or frame and the hinged part of the knotted-shaft journaled thereon, substantially as described. 5th. The combination of the cam-wheel A₁, the shaft D₁ and tubular shaft or sleeve D₂ mounted and turning on said shaft D₁, the vibrating arm or frame E, knotted B₂ and cord-disc G, and their supporting and actuating devices, substantially as described, whereby said knotted and disc are both vibrated from the same cam. 6th. The rock shaft D₁ and rocking sleeve D₂ mounted thereon, both connected with and adapted to be operated by the same cam, in combination with the cord-holder arm supported by and vibrating on said shaft, the swinging arm carrying the knotted, and the knife for severing the cord, and mechanism, substantially as described, for actuating said cord-holder and knotted-carrying arms. 7th. The combination of the cord-holding disc, its actuating pawl g_2 , the connecting-rod H and the spring H₂ arranged to be disengaged from said pawl, when the latter is raised in operating the disc, and to be brought into contact therewith when the pawl is depressed, substantially as described. 8th. The combination of the jointed knotted-shaft and the hinged arm or frame supporting the swinging end of said shaft, the joint in the shaft and the frame pivot being arranged to coincide, substantially as described. 9th. The swinging cord-holder arm or frame, provided with the fork or arms d_2 and d_3 and the cam on the cam-wheel shaft for actuating the same, in combination with the hinged arm of the knotted-frame, carrying the hinged end of the knotted-shaft knotted, and means, substantially as described, for vibrating said hinged arm of the knotted-frame and knotted.

No. 26,859. Bayonet. (*Baïonnette.*)

Conrad Schills and Lewis Stucker, Canton, Ohio, U. S., 4th June, 1887; 5 years.

Claim.—The combination of the sword or bayonet A, having formed integral therewith, the shank B and the head a , the hilt C provided with the apertures B and D, and the recess c , the lever E pivotally attached to the hilt C, the spring F, the handle or cheek-pieces G and the projection or sight d , substantially as and for the purpose specified.

No. 26,860. Seed Drill. (*Semoir en ligne*).

Edison J. Corser and George W. Kirkpatrick, Macedon, N.Y., U.S., 4th June, 1887; 5 years.

Claim.—1st. The combination, in a seed drill, of a suitable casing and a revolving laterally adjustable distributor, consisting of revolving shell E and feed-wheel F, substantially as described. 2nd. The combination, with the laterally adjustable revolving feed-wheel F, of the shell E arranged to receive motion from the wheel, substantially as described. 3rd. The combination, with the longitudinally adjustable shaft G, of the feed-wheel F secured thereto, and the shell E provided with one or more ribs *n* fitting a corresponding notch or notches in the wheel, substantially as described. 4th. The combination of the longitudinally adjustable shaft G, feed-wheel F, provided with hubs *a*, *a'* and flange *l*, of the shell E arranged to be rotated by the wheel, substantially as described. 5th. The combination, with the laterally adjustable feed-wheel F provided with hubs *a*, *a'* and flange *l*, of the revolving shell E, and the casing B C having suitable inlet and discharge passages for the grain, and a recess within which the shell revolves, substantially as described. 6th. The combination, with the laterally adjustable revolving feed-wheel F, of the revolving shell E and movable partition I, substantially as described. 7th. The combination, with the laterally adjustable revolving feed-wheel F, of the revolving shell E and movable partition I, provided with deflector J, substantially as described. 8th. The combination, with the longitudinally adjustable shaft G, of the feed-wheel F secured thereto, the revolving shell E, and movable partition I connected with the shaft so as to be adjusted therewith, substantially as described. 9th. The combination, with the longitudinally adjustable shaft G, of the feed-wheel F secured thereto, the revolving shell E, movable partition I having one or more arms *c* arranged to engage with groove *z* in order to secure the simultaneous adjustment of the feed-wheel and partition, substantially as described. 10th. The combination, with the revolving shell E provided on its inner surface with a series of ribs *n*, of the laterally adjustable feed-wheel F having a series of notches in its circumference adapted to receive the said ribs, and a series of projections *o* on the inner beveled surface of the flange *l*, substantially as described. 11th. The combination, with the revolving shell E, of the laterally adjustable feed-wheel F and the movable partition I provided with deflection J having groove *z*, substantially as described. 12th. The combination, in a grain-drill, of the revolving shell E, feed-wheel F and longitudinally adjustable shaft G having indicator L and pointer N, substantially as described. 13th. The combination, with the revolving shell E, of the laterally adjustable flanged feed-wheel F arranged within E, of the shell, and adapted to form a throat or grain discharge passage of variable dimensions within the shell by its adjustment to and from the opposing surface of the case, substantially as described. 14th. The combination, with the revolving shell E, of the laterally adjustable feed-wheel F, and movable partition I, provided with plate H, substantially as described.

No. 26,861. Paper Pulp Screen.

(*Tamis à Pâte à papier*).

The Seneca Screen Company (assignee of Calvin Russell and Patrick H. Cragin), Penn Yan, N.Y., U.S., 4th June, 1887; 5 years.

Claim.—1st. In combination with the paper pulp screen, a series of pulp compartments separated from each other by intervening partitions extending to the underside of the screen, and a series of pumping bars or plungers arranged respectively in the said compartments, substantially as set forth. 2nd. The combination, with the vat screen and plungers in the vat, of partitions arranged between said plungers, and provided with indentations on their tops and strips secured to the underside of the screen, and adapted to rest in the said indentation and support the central portion of the screen in the vat, substantially as set forth and shown. 3rd. In combination with the vat and screen, the oscillatory pumping bars A, A provided with the longitudinal rib or ribs *r*, substantially as described and shown. 4th. In combination with the screen C and pumping bars A, A, the vat V provided with ports *p*, the apron L secured to the exterior of the vat below the ports thereof, and extending above the water line of the vat and the crank arms *b*, *b'* extending through the ports and up over the top of the apron and pivoted to the exterior thereof, substantially as described and shown. 5th. The combination, with the vat V, of the pulp screen hinged on said vat, as set forth. 6th. The combination, with the vat V, of a frame removably connected to said vat, and the screen secured to said frame, substantially as described and shown. 7th. The combination, with the vat V, of a frame removably connected to said vat, the screen secured to said frame, and partitions in the vat supporting the central portion of the screen, substantially as shown and set forth. 8th. The pumping bars provided with a trunnion on one end, in combination with the vat provided with openings at said ends of the bars, and covering plates detachably secured in said openings, and provided with bearings for the trunnions of the pumping bars, substantially as described and shown.

No. 26,862. Acoustic or Tone Telegraph.

(*Télégraphe Asique*).

William T. Barnard, Charles Selden, Baltimore, Md., U.S., and François Van Rysselberghe, Brussels, Belgium, 4th June, 1887; 5 years.

Claim.—1st. As an improvement in the art of multiple telegraphy, the method, substantially as hereinbefore described, consisting in producing upon a line superimposed series of impulses, and in analyzing such superimposed series of electrical impulses made audible in a receiver. 2nd. As an improvement in the art of multiple telegraphy, the method substantially as hereinbefore described, consisting in producing upon a line superimposed series of impulses, and in reproducing in a receiver such superimposed series of impulses and separating each series from the other acoustically. 3rd. The combination of a main line over which several series of electrical impulses are transmitted, a receiver responding to all of these impulses simultaneously and analyzers, substantially as described. 4th. The com-

bination of a main line over which several series of electrical impulses are simultaneously transmitted, one or more receivers responding to all of these impulses and analyzers, each corresponding to one of the series of impulses, substantially as described.

No. 26,863. Punching and Shearing Machine. (*Machine à découper et cisailier*.)

George S. Brown, Eureka Springs, Ark. (assignee of Gilbert McDonald, Augusta, Ks.), 4th June, 1887; 15 years.

Claim.—1st. The combination of the plunger D having the friction-roller F, and the friction-roller G journaled above with the wedge H, the pitman L, eccentrics P, shaft M, and lever N, substantially as herein set forth. 2nd. The combination of the shaft M, lever N, and crank Y, with the shear V, upright U, and the pitman Y', substantially as herein set forth. 3rd. The combination of the plunger D, the perforated plate C, and the projecting arm B', with the arm R, pitman S, and lug T upon the lever N, substantially as herein set forth. 4th. The combination of the shaft M, the lever N, the crank Y, and the pitman Y', with the shear-lever V, the eccentrics pitman Y, and the pitman Y', whereby the plunger D and the shear may be operated simultaneously by a single movement of the lever N, substantially as set forth. 5th. The combination of the frame A having the opening B and arm B' and plate C therein, the friction-rollers F and G and plunger D with the wedge H, pitman L, eccentrics P and lever N, substantially as herein set forth. 6th. The combination of the frame A and the lever V having shears W and W', with the pitman Y', crank Y, lever N, lug T, arm R, and the plunger D, substantially as herein set forth. 7th. The combination of the frame A, plunger D, shaft M, lever N, eccentrics P, pitman L, and wedge H, with the pitman Y', lever V, and rollers F and G, substantially as and for the purpose herein set forth and described.

No. 26,864. Car-Coupling. (*Attelage de chars*.)

Isaac N. Gillock and James R. Crump, Horse Cave, Ky., U.S., 4th June, 1887; 5 years.

Claim.—1st. In a car-coupler, the combination of a draw-head having a hook upon its end, and an upwardly-extending projection upon its intermediate portion, a detachable link having its rear end square, a bail secured to the middle of said link, a flat bar secured at its lower end in said bail rectangular bearings upon the end of the car, and a handle upon the upper end of said bar, as described. 2nd. In a car-coupler, the combination of a draw-head having a hook upon its end, and an upwardly-extending projection upon its intermediate portion, a recessed block upon the end of the car, a detachable link having its rear end square, a bail secured to the middle of said link, a flat bar secured to said bail and rectangular bearings upon the end of the car, as described and shown.

No. 26,865. Organ Pedal. (*Pédale d'orgue*.)

James S. Foley, Chicago, Ill., U.S., and Joseph Ruse, Toronto, Ont., 4th June, 1887; 5 years.

Claim.—1st. The mouldings A adjustably connected to the pedal B, in combination with mechanism designed to press the said mouldings A outwardly against the side of the pedal-box, when the pedals are in their normal position, substantially as and for the purpose specified. 2nd. The side-plates C, rigidly secured to the side mouldings A, and laterally adjustably connected to the pedal B, the centre plate D longitudinally adjustably connected to the pedal B, and by the arms E to the plates C, in combination with mechanism designed to press the mouldings A outwardly against the side of the pedal-box, when the pedals are in their normal position, substantially as and for the purpose specified. 3rd. The side-plates C rigidly secured to the side mouldings A and laterally, adjustably connected to the pedal B, the centre plate D longitudinally adjustably connected to the pedal B, and by the arms E to the plates C, in combination with the double crank G journaled in the pedal B, and connected by one of its arms to the plate D, and having its other arm bifurcated and designed to come in contact with the skirting F, substantially as and for the purpose specified. 4th. The mouldings A, adjustably connected to the pedal B and connected to the plate D by the arms E, in combination with the link J pivoted at one end to the frame of the instrument, and connected at its other end to the plate D, substantially as and for the purpose specified. 5th. The mouldings A, adjustably connected to the pedal B by means of the pins *i*, and connected to the plate D by the arms E, in combination with the link J pivoted at one end on the frame of the instrument, and at its other end to the saddle I which is adjustably connected to the plate D, substantially as and for the purpose specified.

No. 26,866. Sharpening Attachment for Tools. (*Appareil à aiguiser les outils*.)

James S. Foley, Chicago, Ill., U.S., and Joseph Ruse, Toronto, Ont., 4th June, 1887; 5 years.

Claim.—1st. The combination, with a plate of casters connected thereto, a tilting shaft carried thereby, and a tool clamp arranged in connection with the shaft, substantially as described. 2nd. The combination, with a plate of casters carried thereby, a tilting shaft supported upon the plate and formed with a slot adapted to receive a tool clamp, said tool clamp and a clamping nut arranged in connection therewith, substantially as described. 3rd. The combination, with a plate of casters adjustably connected thereto, a standard also adjustably connected to the plate, a shaft adjustably connected to the standard, and a tool clamp carried by the shaft, substantially as described. 4th. The combination, with a plate of casters 11, thumb-nuts 12, arranged in connection with the casters, a standard 14, a screw 15, arranged in connection therewith, a shaft 16, having a flattened face 2, and a recess 3, a thumb-screw 18, by which the shaft 16, is connected to the standard 14, a tool clamp 20, having an aperture 4, and a shaft 19, and a nut 21, arranged in connection with the tool clamp, substantially as described.

No. 26,867. Fire-Escape. (*Sauveteur d'incendie.*)

William O'Neil, Toronto, Ont., 5th June, 1887; 5 years.

Claim.—As an improved fire-escape, the straps D connected to the shaft B, and having the bar E attached to them, the hooks M for supporting the said bar, in combination with the cage F attached to the ring G, which is supported by the rollers H resting on the straps D, and the rope K passing through the pulley-block J suspended from the bar E, substantially as and for the purpose specified.

No. 26,868. Spring Coupling for Vehicles.*(Joint de ressort de voiture.)*

Henry W. Pell, Rome, N. Y., U. S., 5th June, 1887; 5 years.

Claim.—1st. The combination of the side spring and cross spring, lapped one across the end portion of the other, the head C projecting beyond the end of the side spring and formed with the shoulder b, abutting against the end of the side spring, and having a lip or lips extending lengthwise the side spring and beyond the lapped portions of the two springs, and a clip tying said lip or lips and lapped portions of the springs together, substantially as set forth and shown. 2nd. The combination, with the side spring and end spring lapped one upon the other at their ends, of the coupling head C projecting from the end of the side spring and formed with lips l, l', extending lengthwise the side spring and embracing the lapped end portions of the two springs, and fastened to the top and bottom of the side spring back of the cross spring, substantially as described and shown. 3rd. The combination, with the side spring and cross spring lapped one upon the other at their ends, of the coupling head C having lips l, l', embracing the lapped portions of the springs, and linings interposed between embraced portions of the springs, substantially as described and shown. 4th. The combination, with the side spring and cross spring lapped one upon the other at their ends, of the coupling head C having lips l, l', embracing the lapped portions of the springs and fastened to the side spring back of the cross spring, and a clip placed astride one of the lips of the coupling head C and fastened to the cross spring, substantially as described and shown.

No. 26,869. Drip Coffee-Pot. (*Percolateur.*)

Ferdinand Ribbeck, New Iberia, La., U. S., 6th June, 1887; 5 years.

Claim.—1st. The combination of a pot having a spout at one side and having a neck at its top, an ear secured to said neck, a coffee receptacle having a strainer and a funnel-shaped flange at one end and a strainer-cap at the other, and a handle secured to said flange and having a lip at its lower end to fit into said ear, substantially as and for the purpose set forth. 2nd. In a drip coffee-pot, the combination of a boiler having a neck at its top, and having a suitable handle, a coffee-receptacle fitting with one end removably upon the neck of the boiler, and having a tapering steam-escape tube passing through it, provided with a valve opening toward the boiler and having strainers at the ends, and a pot having a spout, and having a neck at its top for the reception of one end of the coffee-receptacle, as and for the purpose shown and set forth. 3rd. In a drip coffee-pot, the combination of a conical boiler having a screw-threaded neck at its apex and provided with a handle, a cylindrical coffee-receptacle having a strainer and a funnel-shaped flange at one end, and a strainer-cap screwed upon the other end, a pot having a spout and provided with a cylindrical neck fitting over the coffee-receptacle and formed with a handle, an ear at the side of the neck, a handle secured by one end to the flange of the coffee-receptacle, and having a lip formed at its other end, and a hook secured to said flange, as and for the purpose shown and set forth.

No. 26,870. Air and Gas Mixing Process and Supplying Apparatus. (*Procédé pour mêler et appareil pour distribuer l'air et le gaz.*)

George E. Benningshoff, Kendall, Penn., U. S., 5th June, 1887; 5 years.

Claim.—1st. The within-described method of mixing air and gas and transmitting and distributing the same in a mixed state, and maintaining the mixture in a state adapted to illuminating and heating purposes, such method consisting in simultaneously drawing gas and air through intersecting conduits with a suitable mixing and forcing engine, and forcing and supplying a portion for use through a main beginning at the issue side of the mixing and forcing engine, and extended in a circuitous direction back to the section side of the mixing and forcing engine, and delivering the surplus of the mixed air and gas into the mixing and forcing engine and thereby maintaining a continuous movement of the mixture, substantially as specified for the purpose hereinbefore set forth. 2nd. The combination of a suitable air and gas mixing and forcing engine, a receiving main provided with suitable distributing conduits and extending from the issue side of the mixing and forcing engine back to, and arranged to communicate with the mixing and forcing engine through its suction side, a reservoir connected with the main, an air induction conduit, conduits for admitting gas into the air induction conduit and into the main at the issue side of the mixing and forcing engine, and the conduit connected with the reservoir and arranged to communicate with the main at the suction side of the mixing and forcing engine, substantially as and for the purpose hereinbefore set forth. 3rd. The combination, with a suitable air and gas mixing and forcing engine, a main provided with suitable distributing conduits and a reservoir, and extended in a circuitous direction from the issue side of the mixing and forcing engine back to, and arranged to communicate with, the mixing and forcing engine through its suction side, an air induction conduit and into the main at the issue side of the mixing and forcing engine, of a conduit connected with the reservoir and arranged to communicate with the main at the suction side of the mixing and forcing engine, substantially as and for the purpose hereinbefore set forth. 4th. The combination of a circuitous transmitting main provided with suitable forcing and distributing mechanism, and a direct transmitting main provided with suitable air

and gas mixing and forcing mechanism, substantially as and for the purpose hereinbefore set forth. 5th. The combination, with a direct transmitting main, suitable air and gas mixing and forcing mechanism and conduits extended from, and returned to the direct transmitting main, substantially as and for the purpose hereinbefore set forth.

No. 26,871. Baling Press. (*Presse d'empaquetage.*)

George Ertel, Quincy, Ill., U. S., 5th June, 1887; 5 years.

Claim.—1st. A baling-press comprising a case, a plunger operating therein, top and side feed-doors provided with latch devices and connections from said latch devices adapted for alternate attachment to the plunger, substantially as shown and described, whereby either the top or side feed-door may be unlatched for opening by the movement of the plunger, as set forth. 2nd. A baling-press having its bottom planking or lining made in two sections spaced apart to provide a dust-exit slot, as at E, at the bottom of the feed-opening of the press-case, substantially as described for the purposes set forth. 3rd. In a baling-press, the combination, with the press-case and a top feed-door, as at B, hinged thereto, of a tube G fixed to the case, a spring, as at H, fitted in the tube, and connections from the back end of the spring to the door, substantially as shown and described, whereby the spring will be put in tension by the closing of the door and will automatically open the door when said door is unlatched, as set forth. 4th. In a baling-press, the combination, with the press-case having a top feed-opening and a door B hinged thereat, of rods B₂, G, a tube G₁ into which rod G passes, and a spring, as at H, fitted in the tube between one end of it and a shoulder on the rod G, substantially as herein set forth. 5th. In a baling-press, the combination, with the press-case having a top feed-opening, a door B hinged thereat, a latch, as at F, on the door adapted to engage a catch-plate on the press-case, and a plunger working in the case, of a chain I, lever I₁, and a rod J connected to the lever I and to the plunger, substantially as shown and described. 6th. In a baling-press, the combination, with the press-case having a top feed-opening, a door B hinged thereat, a latch, as at F, on the door adapted to engage a plate on the press-case, and a plunger working in the case, of a chain I, lever I₁, rod J, a plate, as at K, on the plunger, and a stop or nut l on the rod J, substantially as described for the purpose set forth. 7th. In a baling-press, the combination, with the press-case, and a plunger operating therein, of a brake-lever, as at N, hung so as to be adjustable vertically at the top of the press-case and adapted to clamp the plunger automatically about at the limit of the back stroke of the plunger, and a vertically-movable fulcrum pin or shaft, as at P, fitted in the press-case and bearing on the brake-lever and adapted to adjust it bodily to the plunger, substantially as described for the purpose set forth. 8th. In a baling-press, the combination, with the press-case and a plunger operating therein, of a brake-lever N hung at the top of the press-case by a pin or bolt n, and a spring n₁, and adapted to clamp the plunger automatically at the limit of the back-stroke of the plunger, and a vertically-movable fulcrum pin or shaft, as at P, fitted in the press-case and bearing on the lever and adapted to adjust it bodily to the plunger, substantially as herein set forth. 9th. In a baling-press, the combination, with the press-case and a plunger operating therein, of a brake-lever held to the case and provided with an inclined clamp-block N₁, and a correspondingly-inclined block D₁ on the plunger, substantially as herein set forth. 10th. In a baling-press, the combination, with the press-case and a plunger operating therein, of a brake-lever N hung at the top of the case by a pin or bolt n and a spring n₁, a vertically-movable fulcrum pin or shaft, as at P, fitted in the press-case and bearing on lever, and adapted to adjust it bodily to the plunger, and inclined blocks N₁, D₁, on the brake-lever and plunger respectively, substantially as herein set forth. 11th. In a baling-press, the combination, with the press-case and a plunger operating therein, of a brake-lever N hung at the top of the case and provided with inclined and flat clamp-plates N₁, N₂, a vertically-movable fulcrum pin or shaft, as at P, fitted in the press-case and bearing on the lever, and inclined and flat clamp-plates D₁, D₂ fixed to the plunger, substantially as herein set forth. 12th. In a baling-press, the combination, with the press-case, and a plunger operating therein, of a retainer T formed with a pendent lip t and a stop t₁, and pivoted, as at S, at the rear end of a top feed-opening of the press-case, and said case cut away at a₅, to relieve the lip t, and having a stop flange or lip a₄, which the retainer-stop t₁ is adapted to strike, substantially as herein set forth.

No. 26,872. Adjustable Plough Handle.*(Manchurons de charrue mobiles.)*

Silvarius R. Montcalm, McDaniel, Ark., U. S., 5th June, 1887; 5 years.

Claim.—The combination of the plough-handle provided at its inner end with a transverse bolt for pivotally attaching the handle to plough-beams and an additional transverse bolt for securing the handle in an adjusted position, and a plough-beam having an integral bifurcated curve or shovel helve, and an integral rearward extension provided with a perforation for the reception of the bolt, for pivotally attaching the handle, and a series of perforations for adjusting the bolt for securing the handle in an adjusted position, as shown and described.

No. 26,873. Bob Sled. (*Traineau accouplé.*)

Farge G. Mandt, Stoughton, Wis., U. S., 5th June, 1887; 5 years.

Claim.—1st. In a sled, the combination, with the runner of a knee having divergently curved legs formed with upwardly tapering flanges upon their inner edges and having the lower ends of the said flanges extended forming lips bearing against the inner side of the runner, as and for the purpose shown and set forth. 2nd. In a sled, the combination of a knee having a semi-cylindrical bearing formed at its doubled or curved upper end and having flat faces at the side of the bearing, a beam having a corresponding recess and having a metallic facing, and a bail having its ends passing upward through the beam, and having its middle portion fitting into the concave side

of the bearing of the knee, as and for the purpose shown and set forth.

No. 26,874. Churn. (*Baratte.*)

Stephen F. Keirstead, St. John, N.B., 5th June, 1887; 5 years

Claim.—1st. The combination of the creamer and the cream preserver by the coupling at G and E, with the rubber tubing B and the clasp A, substantially as and for the purpose hereinbefore set forth. 2nd. The combination, with the creamer and the cream preserver coupled at G and E, with the rubber tubing B and clasp A, of the hooks H, H, cords J, J, and rings C, C, substantially as and for the purpose hereinbefore set forth.

No. 26,875. Process of Evaporating Sugar Solutions and other Liquids, and Apparatus for Carrying on the same. (*Procédé d'évaporation des solutions saccharines et autres liquides, et appareil pour cet objet.*)

Samuel M. Lillie, Philadelphia, Penn., U.S., 5th June, 1887; 5 years.

Claim.—1st. In an apparatus for evaporating liquids, a series of vertical, or approximately vertical, surfaces, heated by steam or otherwise, means for delivering the liquid to be evaporated upon each surface at or near the top, and means for maintaining a vacuum, more or less perfect, in the spaces in which the surfaces are exposed, substantially as specified. 2nd. The within described apparatus for evaporating liquids, consisting of a battery of vertical tubes, surrounded by a heating chamber, means for delivering the liquid to be evaporated upon the interior surfaces of each tube, near its upper end, means for the escape of the vapors of evaporation from the end of the tubes, and means for maintaining a more or less perfect vacuum in the interiors of the tubes, substantially as specified. 3rd. In an apparatus for the evaporation of liquids, the combination of a battery of vertical tubes extending through a heating chamber E, a chamber G above the heating chamber for receiving the liquid that is to be evaporated, channels leading from the chamber G into the interior of the tubes and adapted to deliver the liquid over the inner surfaces of the same, and means for maintaining a more or less perfect vacuum in the tubes, substantially as specified. 4th. In an apparatus for evaporating liquids, the combination of the heating chamber containing the battery of tubes *b*, chamber G communicating with the interiors of the tubes, as described, chamber P and conduit Y connecting the chamber or well P with a suitable vacuum-inducing apparatus, substantially as described. 5th. In an apparatus for evaporating liquids, the combination of a battery of tubes contained in a heating chamber, means for delivering a liquid upon the interior surfaces of the tubes near their upper ends, well P for receiving the vapors and unevaporated liquid from the lower ends of the tubes, and means for maintaining a more or less perfect vacuum in the well P, substantially as specified. 6th. In an evaporating apparatus, constructed and operating, as set forth, the combination of a battery of tubes *b* contained in a suitable heating chamber, well P, with which the lower ends of the tubes communicate, and into which the unevaporated liquid from the same flows, and a pump or equivalent means for returning liquid from the well P onto the interior surfaces of the tubes, substantially as specified. 7th. In an evaporating apparatus, the combination of the heating chamber E, battery of tubes *b*, dome D communicating with the tubes *b* at their upper extremities, means for maintaining a more or less perfect vacuum in the dome D, means for distributing a liquid over the interior surfaces of the tubes, and well P for receiving the liquid that may flow from the lower ends of the tubes *b*, substantially as specified. 8th. The combination, in an evaporating apparatus, of the chamber E, dome D, well P, tubes *b* extending through chamber E and communicating above with the dome D, and below with the well P, means for delivering a liquid upon the interior surfaces of each tube, near the top, and suitable vacuum apparatus communicating with dome D and with the well P, and adapted to maintain a partial vacuum in both, substantially as specified. 9th. The combination, in an evaporating apparatus, of the heating chamber E, chamber G, dome D, well P, tubes *b* extending through the heating chamber, and *d* communicating above and below respectively with the dome D and well P, suitable channels leading from the chamber G into the interior of each tube, and means for introducing the liquid to be evaporated into the chamber G, substantially as specified. 10th. The combination, in an evaporating apparatus, of the chamber E, dome D, chamber G, well P, tubes *b*, tubes *c* extending from dome D into the upper ends of tubes *b*, and channels in walls of tubes *c*, between G and the interiors of tubes *b*, substantially as specified. 11th. In an evaporating apparatus, constructed substantially as described, the combination, with the chamber G and well P, of a pump M, or other suitable means for returning liquid from the well P into the chamber G, substantially as described. 12th. In an evaporating apparatus, the combination of the heating chamber E, dome D, well P, tubes *b* extending through the heating chamber, and communicating above and below respectively with the dome D and well P, and means for delivering the liquid to be evaporated onto the interior surfaces of the tubes, substantially as specified. 13th. In an evaporating apparatus, the combination of the heating chamber E, dome D, well P, tubes *b* in the heating chamber, and communicating above and below respectively with the dome D and well P, and a pump with proper connection or other suitable means for delivering liquid from the well P upon the interior surfaces of the tubes, substantially as specified.

No. 26,876. Steel Horse Check-Rein and Nose Extender. (*Fausse-Rénes.*)

Thomas J. Quinn and Donald McLellan, Woodstock, Ont., 5th June, 1887; 5 years.

Claim.—The combination of the longer arm or check-rein B, A, and the shorter arm or check piece A, C, adjusted by means of the brace D, E, and its sliding spring, and fastened to the bit by the

spring safety lock in the manner described and substantially as and for the purpose hereinbefore set forth.

No. 26,877. Manufacture of Blood Albumen.

(*Fabrication de l'albumine sanguine.*)

Thorsten Nordenfelt, Westminster, Eng., 5th June, 1887; 5 years.

Claim.—1st. My improvements in the manufacture of blood albumen, consisting in separating by stirring or whisking the fibrine from blood, then adding sugar and a volatile oil, afterwards separating the heavier particles by centrifugal action, and finally evaporating and drying the albumen, substantially as described. 2nd. My improvement in the manufacture of blood albumen, by the addition thereto whilst under process of manufacture of sugar and a volatile oil, or either of them, substantially as described. 3rd. My improvement in the manufacture of blood albumen, consisting in the separation from serum of blood corpuscles by passing the material through a centrifugal machine, substantially as described.

No. 26,878. Electric Conductor.

(*Conducteur d'électricité.*)

Henry F. Campbell, Boston, Mass., U.S., 6th June, 1887; 5 years.

Claim.—1st. An electric stranded conductor, composed of two or more strands, strips, tapes or wires of iron twisted together, as and for the purpose described. 2nd. An electric stranded conductor, composed of two or more strands, strips, tapes, or wires of annealed iron twisted together, as and for the purpose described. 3rd. An electric stranded conductor, composed of two or more strands, strips, tapes, or wires of iron twisted together, and provided with a covering of insulating material, substantially as described. 4th. An electric stranded conductor, composed of two or more independent stranded conductors twisted together, each stranded conductor being composed of two or more strands, strips, tapes or wires of iron twisted together, substantially as described. 5th. A cable, composed of two or more independent stranded conductors grouped together and separated by insulation, each stranded conductor being composed of two or more strands, strips, tapes, or wires of iron twisted together, the said stranded conductors grouped together, being covered with insulation, substantially as described.

No. 26,879. Dental Disk. (*Disc dentaire.*)

Benjamin H. Teague, Aiken, S.C., U.S., 6th June, 1887; 5 years.

Claim.—A dental polishing tool, consisting of a concavo-convex disk of sand or emery, paper, or emery or crocus cloth, coated upon its back with shellac varnish and a solution of sandarac, as and for the purpose described.

No. 26,880. Surgeon's Combined Chair and Table. (*Fauteuil-table de chirurgie.*)

Albert J. Marston, Worcester, Mass., U.S., 6th June, 1887; 5 years.

Claim.—1st. The back frame *e*, bail-brace *i* hinged to the upper end of said frame, frame *f* having one or more supporting shoulders upon the upper side thereof to receive the bottom of said bail-brace *i*, and an adjustable device arranged on one of the legs of frame *f* for holding the bail-brace in said notches, comprising a hinged lever provided with hooks or projections upon the upper side thereof, adapted to engage with and hold the bottom of the brace, also provided with means for forcing said lever towards the holding notches aforesaid, and means whereby it may be forced back therefrom, in combination with frame *g* hinged at the upper end to the upper end of frame *e*, frame *h* hinged to the lower end of frame *g*, and adjustable means connected with the outer end of frame *h*, and the bottom of frame *e* for supporting said outer end of frame *h*, substantially as shown and specified. 2nd. An adjustable device arranged on one of the legs of the back supporting frame *f* for holding the bottom of the bail-brace in the notches formed in the top side of said frame, comprising a hinged lever provided with hooks or projections upon the top side thereof, adapted to engage with and hold said bottom of the bail-brace, means for forcing said lever towards the notches and bail-brace, and means whereby it may be forced back therefrom to release said bail-brace, substantially as shown and specified. 3rd. In a surgeon's combined operating chair and table, the extension frame *g* provided with the projecting rod or bar *γ* upon the under side thereof, fork-shaped at its extremity, also provided with two or more dowels upon its abutting edge, in combination with the frame *g* provided with the openings *γ* in the end and side edges thereof, also with the holding loops *γ*₂, *γ*₃, and the fastening screw and nut *γ*₄, *γ*₅ or their equivalents, whereby said extension frame may be fastened upon the end or one side of frame *g*, substantially as and for the purposes set forth. 4th. In a surgeon's combined operating chair and table, the extension supporting brace *k* hinged at the bottom to the lower end of the back-supporting frame *e*, and provided with the extension bar *κ* fitted to slide longitudinally in the central part of said brace, also provided with the set screw *u* and nut *v* or their equivalents, for fastening the aforesaid rod or bar after adjustment to the body of the brace, in combination with the frames *e*, *f*, *g*, *h*, bail-braces *i*, *j*, and means for fastening the upper end of said brace *k* to the front end of frame *h*, said frames being hinged together, and the bail-braces hinged to the frames *e* and *g* respectively, the latter also being supported and held in notches or shoulders formed in the top surfaces of the frames *e* and *f*, substantially as shown and specified. 5th. Means for fastening the hinged frames *g* *h* to frame *e*, when the several parts are converted into a chair, consisting of the hook *w* hinged to the bottom of frame *g*, or near where the frames *g*, *h* are hinged together, and plate *x* fastened to the cross piece *z* of frame *e*, having a projection above said cross-piece for the hook *w* to engage with, and projecting below the cross-piece to form a stop for the hinged brace *k* to strike against when detached and swung down, in combination with the frames *e*, *f*, *g*, *h*, and bail-braces *i*, *j*, all constructed, arranged and hinged substantially as shown and specified. 6th. The combination of the frame *g*, provided with guiding and holding parts *z*¹, with the slide bars *z*, *z*²,

having suitable foot rests at their outer ends and stops at their inner ends, substantially as shown and described. 7th. A surgeon's combined operating chair and table, comprising, in combination, the top frames *g, h*, hinged together, the long supporting frame *c* hinged at its upper end to the outer end of frame *g*, and provided with one or more bail-brace holding notches upon its upper side, the back supporting frame *f* hinged at one end to frame *e* at about its centre, and provided with one or more bail-brace supporting notches upon its upper side, bail-braces *i, j*, hinged respectively to frames *e* and *g*, the front extension brace *k* hinged to the bottom of long frame *e*, also provided with means for fastening the upper end thereof to the front end of frame *h*, and for fastening its extension part to the body or main part of the braces after adjustment, means for fastening the hinged frames *g, h* to the frame *e*, when the various parts are converted into a chair, adjustable means for holding the bottom of bail-brace *i* in the supporting notches in frame *f*, the adjustable extension frame *y*, provided with means for fastening the same to the end on one side of the frame *g*, and foot-rests *z, z*, provided with means for guiding and controlling the movements thereof in drawing out and pushing back the same from and towards the frame *g*, all constructed and arranged to be adjusted and operated, substantially as shown and specified.

No. 26,881. Ticket Case. (*Boîte à billets.*)

James M. Harper, Peoria, Ill., U.S., 6th June, 1887; 5 years.

Claim.—1st. A ticket-case for continuous-strip tickets, said case consisting of dual sections freely united to revolve about each other and to inclose the ticket-coil, the contiguous walls of said sections being provided with openings therein to allow the strip to pass, and being spaced with respect to each other so that a portion of the strip may be wound between said walls, substantially as described. 2nd. A ticket-case for continuous-strip tickets, said case consisting of dual sections freely united to revolve about each other, and to inclose the ticket-coil, one of said sections having stud or arbor about which the ticket-coil may centre, while the contiguous walls of both of said sections are provided with openings therein to allow the strip to pass, and are spaced with respect to each other so as to receive a portion of the strip between said walls, substantially as described. 3rd. A ticket-case for continuous-strip tickets, said case consisting of two cup-like sections, one of said sections having a stud or arbor, which arbor the other section is detachably united to inclose the coil, said sections being free to revolve about each other while the contiguous walls thereof are suitably slotted to admit the strip to pass, and are also set at such distance apart as to receive a portion of the strip between said walls, substantially as described. 4th. In ticket-cases, the combination, with the cup-like section A having the arbor *a* about which the ticket-coil may centre of the cup-like section B, and screw-fastener *c* resting thereon, the contiguous walls of said sections being interspaced to admit a portion of the ticket-strip between them, and said fastener being received within and bearing against the arbor *a*, whereby said sections are united to revolve freely past each other in either direction, substantially as described. 5th. In ticket-cases, the combination, with the cup-like section A having the raised bead *a* thereon, of the cup-like section B, the wall of which bears against said bead, the sections specified being freely united to revolve about each other while the contiguous walls of the sections are slotted to allow the strip to pass, and are spaced also with respect to each other so as to receive a portion of the strip between said wall, substantially as described. 6th. In ticket-cases, the combination, with the cup-like section A having the arbor *a* and the bead *a* thereon, of the cup-like section B and the screw-fastener *c* to unite said sections together, in manner free to revolve the contiguous walls of said sections, being slotted and also interspaced to admit a portion of the ticket-strip therein, substantially as described. 7th. In ticket-cases, the combination, with the cup-like section A, and with the companion section B having raised boss thereon, of the screw-fastener uniting said section together, and the protective cap covering the head of said fastener and secured to the boss-section, substantially as described. 8th. The combination, with the cup-like section A, of the companion section and the screw-fastener to retain said sections in manner free to revolve about each other, said fastener having an offset or shoulder to bear against said section A, and an enlarged head to loosely retain the companion section in place, substantially as described.

No. 26,882. Drag-Saw Machine.

(*Scièrre à scie traînante.*)

Cornelius W. Wright, Democracy, Ohio, U.S., 6th June, 1887; 5 years.

Claim.—1st. In a portable hand drag-saw machine, the combination, with a frame consisting of the standard A, longitudinal beam B, provided with a U-shaped iron *m* at one end, the plate L secured to said longitudinal beam B and the hinged braces M, of the angular lever D pivoted between the plate L and standard A below said beam, the connecting-rod S and lifting-bar H, the said lifting-bar and connecting-rod slotted at their ends and pivoted by the same pivot-bolt to a saw-handle, substantially as set forth. 2nd. In a portable hand drag-saw machine, the combination, with a frame consisting of the standard A, longitudinal beam B, and plate L, of the hinged braces M attached to said standard and plate, and the U-shaped iron *m* attached to the free end of the said beam, substantially in the manner and for the purpose herein set forth. 3rd. In a portable hand drag-saw machine, the combination, with the standard A having slot *a*, and the beam B having the slot *d* and small standard G, of an adjusting lever K, a thumb-screw *i* in said lever entering said slot *a*, of the standard A and the lifting-bar H, adjustably pivoted to said adjusting-lever K at one end and slotted to receive a saw-handle at the other end, substantially as shown and described and for the purpose herein set forth.

No. 26,883. Privy Seat. (*Siège d'aisance.*)

Charles Kelley, Toronto, and Jacob Ball, Waterloo, Ont., 6th June, 1887; 5 years.

Claim.—1st. A pan D located below the excrement-hole *a*, in com-

bination with mechanism arranged to throw the pan away from the hole upon downward pressure on the seat, substantially as and for the purpose specified. 2nd. The pan A connected to the arm B which is pivoted on one side of the excrement-hole *a*, in combination with the rod I, bell-crank J, and pivoted seat C, arranged substantially as and for the purpose specified. 3rd. The pan A connected to the arm B which is pivoted on one side of the excrement-hole *a*, in combination with the rod I, bell-crank J, and pivoted seat C having a weight K attached to it, substantially as and for the purpose specified. 4th. A seat C pivoted at or near its centre, and provided with an apron *b*, in combination with a bell-crank J, rod I and arm E arranged to carry the pan D, substantially as and for the purpose specified. 5th. The seat C pivoted at or near its centre, and provided with a finger F to act against the cover G, in combination with the pivoted pan D connected to the weighted pivoted seat C, arranged substantially as and for the purpose specified.

No. 26,884. Skeleton Cigar Holder.

(*Porte-cigare pour billard.*)

Murray P. Hough, Chicago, Ill., U.S., 6th June, 1887; 5 years.

Claim.—1st. The holder or receptacle described, consisting of the backing plate A having at its lower edge two projecting skeleton frames B, B to hold a cigar, and at its upper edge two projecting frames C, C to hold matches, substantially as set forth. 2nd. The holder described, consisting of the backing plate A having at its upper edge two projecting frames forming a match receptacle, and at its lower edge two projecting skeleton frames, the parts of which are triangular in cross-section, as and for the purpose set forth.

No. 26,885. Manufacture of Rubber Belting. (*Fabrication des courroies en caoutchouc.*)

Ignace Plamondon and Mallory Palmer, Montreal, Que., 6th June, 1887; 5 years.

Claim.—1st. In a machine for the manufacture of rubber belting, the combination of the folders, mechanism for adjusting the width of opening and equidistance of sides from the centre line, and a downwardly-projecting guide secured to one of the folders and adjusted to the centre line, all as herein described and for the purposes described. 2nd. The combination, with the folders D, D and guide E, of the first roll B with collars B₁ mounted loosely thereon, and means for securing them in place and intermediate rolls C, C, all substantially as described and for the purpose set forth. 3rd. In a machine for the manufacture of rubber belting, the combination, with the folders, of a concave roller driven by power, and a convex roller carried in bearings capable of vertical adjustment, all as and for the purposes described.

No. 26,886. Button and Method of Fastening the Same. (*Bouton et manière de le poser.*)

Richard Jones, Birkenhead, Eng., 6th June, 1887; 5 years.

Claim.—1st. The front part of the button, with cavity spring, tongue, stud and slot, substantially as described and set forth in the drawing. 2nd. The back of the button, consisting of a pin with orifice or slots and head, substantially as described and set forth in the drawing. 3rd. A method of fastening buttons by inserting a slotted pin through the cloth into the front part of the button, and securing the same by a spring tongue, substantially as described. 4th. A button consisting in the pin *s*, provided with the orifice *o*, and in the upper part or front of the button formed by two plates *n, p*, of which the plate *n* is provided with the orifice *d*, and the slit *r*, in combination with the bolt *r*, with knob *k*, and the spring *f*, substantially as described.

No. 26,887. Compound Fabric for Wearing Apparel. (*Tissu composé pour hardes.*)

Albert H. Tuttle, Ionia, Mich., U.S., 6th June, 1887; 5 years.

Claim.—1st. A compound fabric for wearing apparel, composed of sheets or layers of different materials, and an interposed sheet or layer of paper, suitably united or joined together, substantially as described. 2nd. A compound fabric for wearing apparel, composed of sheets of cloth and rubber-tissue, and an interposed sheet of paper, suitably joined together, substantially as described. 3rd. A compound fabric for wearing apparel, composed of five sheets or layers of material, the inner and outer sheets being cloth, the two adjoining sheets, rubber-tissue and the central sheet paper, the whole being cemented together under heat and pressure, substantially as described.

No. 26,888. Measuring Pump.

(*Pompe à compteur.*)

William B. F. Sims, John Loweth, Charles H. Ginkins, Amos Brandenberg, Charles W. Wright, Arthur Dome, William I. Shaffer, Philip E. Lottich and Grant Sims, Corydon, Ind., U.S., 6th June, 1887; 5 years.

Claim.—1st. The combination, with the registering device comprising the dial-faced case inclosing a shaft carrying a pointer, or index, and a pinion geared to a pivoted segment of the pump, piston or head, and the handle connected to said tube and to the registering device, substantially as set forth. 2nd. The combination with the registering device comprising the dial-faced case, inclosing a shaft carrying a pointer or index, and a pinion geared to a pivoted segment of the pump, piston or head, the tube connected to said piston or head, the handle connected to said tube, the connecting-rod attached to the said handle and the arm connected to said connecting-rod and to the shaft or axis of the said segment, substantially as and for the purpose set forth.

No. 26,889. Strength Testing Machine.*(Machine à éprouver la force.)*

Horace Fairbanks and William P. Fairbanks, St Johnsbury, Vt., (assignees of Edwin R. Whitney, Manchester, N. H.), U. S., 6th June, 1887; 5 years.

Claim.—1st. In a therapeutic strength-testing machine, the combination of the following elements: a resisting pull, a battery, an induction coil, one part of which is movable with the pull and connections of secondary coil to handle by which a continuous pull in one direction will cause a constantly increasing induced current to be sent to operator, and the cessation of such pull will diminish and cut off such current. 2nd. In a therapeutic strength testing machine, the combination of a resisting pull, secondary coil connected to same and raised by it primary coil over which secondary coil is drawn, and electrical connections of secondary coil with handle of pull, as and for the purposes set forth. 3rd. The combination of a strength testing machine, induction coil, automatic coin-catching device (arranged to unlock the apparatus so that it can be operated upon when the coin is introduced and indicator showing pounds lifted, and units of electric energy developed, substantially as set forth.

No. 26,890. Neck Yoke. (Volée d'avant.)

Hezekiah Latshaw and Henry J. Stiefelmeyer, New Hamburg, Ont., 6th June, 1887; 5 years.

Claim.—1st. The combination, with the pole A having guard G and neck yoke B, of the straps D connecting curved link plate E and hook F, whereby the neck yoke will sway without rising, as set forth. 2nd. The combination, with the neck yoke B, of the socket tip H having a loop I and hook J and a spring K, as set forth.

No. 26,891. Steam Engine. (Machine à Vapeur.)

Oliver H. Castle, George W. Lutz and Hyam Cohen, Indianapolis, Ind., U.S., 6th June, 1887; 5 years.

Claim.—1st. A steam engine having a trunk piston moving in the bore of its cylinder, and actuated by a rod connected with a crank shaft by a crank inclined at an angle to the line of bearings, such piston provided with ports adapted to be closed and opened by the oscillation and reciprocation of the piston, whereby the outlets and inlets communicate with such ports and admit the steam that drives the engine, substantially as shown and described. 2nd. An engine constructed of a base *b*, forming a crank chamber and oil receptacle into which the crank dips at each revolution, a cylinder *c*, the trunk piston *p* moving in the bore thereof, and connected by the rod *r* with the inclined crank *c* of the crank shaft *c s* journaled in bearings connected with such base, the base and cylinder connected by bolts passing through a flange the cylinder surrounded by a steam jacket *s j*, all combined substantially as described. 3rd. In a steam engine, a crank driving shaft having the center line of its crank wrist set at an angle to the line of bearings, and adapted to conform to the amount of oscillation necessary to be given the piston to allow its ports to be opened and closed as required by its movement substantially as shown and described. 4th. In a steam engine the cylinder *c* having outlet and inlet passages *i, i, i²* and *ex, ex, ex²* for the steam the base *b* having chambers for the lubricant and crank bearings *c, b*, the crank shaft *c s* having crank *c* set at an angle to the axial line of the bearings of the crank shaft the bisected crank boxes *c, b*, the rod *r* and trunk piston *p* having ports *i³, i⁴*, all combined substantially as described. 5th. A steam engine whose base contains space for a lubricant, a crank whose axis is at an angle to that of the driving shaft and of which it forms a part, such crank connected by a rod with a trunk piston having ports which serve as steam inlets when the piston moves in one direction, and as out lets when it moves in the opposite direction, moving in a cylinder having steam and exhaust ports to correspond with those in the piston, the movement of the latter being made oscillatory and reciprocating by the crank connection, all combined substantially as described. 6th. A steam engine whose connection rod is formed in two parts, which at its lower end look over the trunions of the crank box, and at its upper end over those of the cross head forming an universal joint at each end, preventing the piston from binding in the cylinder at any point in the stroke, substantially as described.

No. 26,892. System of Banding for Spinning or Twisting Frames. (Système de Courrois sans fin pour Machines à filer et à Rotordre.)

Thomas Clarke, Richard C. Williams, Truro, N.S., and Oronhyatekha, London, Ont., 6th June, 1887; 5 years.

Claim.—1st. In a spinning or twisting frame, the combination with the spindles and driving roller or drum, of an endless band passed alternately over the drive-drum and around the spindles, as and for the purpose shown and set forth. 2nd. In a spinning or twisting frame, the combination of the spindles and the drive-drum horizontally revolving pulleys placed to the rear of the ends of the drive-drum, and an endless band passed alternately over, the drive-drum and the spindles, and passing from the spindles at the ends of the gang around the end pulleys along the rear side of the frame, as and for the purpose shown and set forth. 3rd. In a spinning or twisting frame, the combination of the spindles, the drive-drum, horizontally revolving pulleys placed in the rear at the ends of the drive-roller, a band passing alternately over the drive-drum or roller and around pulleys upon the spindles, and passing from the spindles at the ends of the gang around the end pulleys along the rear side of the frame, and tension pulleys upon the rear portion of the band having means for forcing them yieldingly against the band, as and for the purpose shown and set forth. 4th. A tension device for spinning and twisting frames, consisting of a drum having central bearings in its heads, a shaft journaled in the bearings and having diverging arms upon its ends, and provided with a ratchet-wheel, a flat helical spring secured to the barrel or drum and to the shaft winding upon the same, a pawl engaging the ratchet wheel and pulleys upon the ends of the

arms of the shaft, as and for the purpose shown and set forth. 5th. In a spinning or twisting frame, the combination of the spindles, the drive-drum, horizontally revolving pulleys placed in the rear at the ends of the drive-drum, a band passing alternately over the drive-drum and around pulleys upon the spindles, and passing from the spindles at the ends of the gang around the end-pulleys along the rear side of the frame, and guide-pulleys having the band passing around their opposite sides, arranged in pairs upon the ends of diverging arms of a shaft having a spring cushioning its turning, as and for the purpose shown and set forth. 6th. In a spinning or twisting frame, the combination of the spindles, the drive-drum composed of sections and having the ends of the sections separated by transverse partitions in the frame, a band passing alternately over the drive-drum and around pulleys upon the spindles, and pulleys secured adjustably upon the partitions and having the band passing around them from the drum, as and for the purpose shown and set forth.

No. 26,893. Reservoir Lamp and System of Lighting. (Lampe à Réservoir et Système d'éclairage.)

The Ross Patent Lighting Company, (assignee of William A. Evans John H. Ross,) Dublin, Ireland, 6th June, 1887; 5 years.

Claim.—1st. The herein described system of illuminating a building with oil, which consists in applying a number of lamps with oil from a common reservoir, substantially as shown and described. 2nd. The herein described system of illuminating a building with oil, which consists in supplying to a number of lamp burners compressed air from a common reservoir, substantially as shown and described, whereby a perfect combustion is obtained and chimneys dispensed with, as set forth. 3rd. The herein described system of illuminating a building with oil, which consists in automatically supplying a number of lamps with oil from a common reservoir, and introducing compressed air to the burners of said lamps also form a common reservoir, substantially as shown and described and for the purposes herein set forth. 4th. The combination, with a lamp provided with a burner and burner cap, and inner tubular casing 23 having an oil chamber 25 and apertures 30 below said chamber, an apertured drip cup 18 and a cone 22 within said tubular casing at the base of the vertical air pipe 32 having a nozzle 28, furnished with a needle valve 29 at its lower end, the tubular connections 13 and 27, the reservoir *l* and compressed air pipe 31, substantially as shown and described and for the purposes set forth. 5th. The combination, with a lamp provided with a burner and burner cap having an outer slotted tubular casing 14, an inner tubular casing 23 provided with an oil chamber 25, apertures 30 below said chamber, and a cone attached at the base and the detachable apertured drip cup 18, of the vertical air pipe 32 provided at its end with valve controlled nozzle 28, the compressed air pipe 31 and reservoir *l*, together with means for connecting the oil chamber 25 with the reservoir and the air pipe 32 with the compressed air pipe 31, substantially as shown and described. 6th. The combination, with a burner, of an apertured tube extending below the same, an outer casing surrounding the burner and tube, a cone in the lower end of said tube, an inspirator at the base of said cone, and a pipe connecting said inspirator with an air forcing device, substantially as shown and described. 7th. The combination, with a burner, of a tube extending below said burner, an oil chamber being formed in said tube, and said tube being apertured below the reservoir, an outer casing for said tube and burner, a cone in the lower end of said tubes, an inspirator at the base of said cone, a pipe connecting said inspirator with an air compressor, and a pipe connecting the oil chamber with an oil reservoir, substantially as shown and described.

No. 26,894. Washing Machine. (Machine à Laver.)

Edward S. Redfern, Sarnia, Ont., 7th June, 1887; 5 years.

Claim.—The combination of the inner tube C having holes K and flaring end G, the outer cylinder A, the plunger rod B provided with a handle, and a plunger D provided with a slot *h* and valve *g* and the handle E, substantially as described and for the purpose specified.

No. 26,895. Wrench. (Clé à écrou.)

John D. Bowman, Altoona, Penn., U.S., 7th June, 1887; 5 years.

Claim.—1st. A wrench for studs or other round metallic bodies, consisting of a sleeve A, A¹ having a serrated eccentric gripping-roller D pivoted in a slot C in one end thereof, and its other end projecting beyond said gripping device, substantially as and for the purpose specified. 2nd. A wrench for studs or other round metallic bodies, consisting of a sleeve A, A¹ having a serrated eccentric roller D pivoted in a slot C formed in one end thereof, and having its other end projecting beyond said gripping device, and adapted to be firmly grasped by a removable actuating wrench or lever, substantially as and for the purposes specified. 3rd. In a wrench, substantially as shown and described, the combination of the sleeve A, A¹ having the V shaped slot *a* and slotted opening C, the serrated eccentric roller D pivoted in said slot, and the sleeve continued above said gripping-roller to form a holding-piece for an actuating-lever, all substantially as specified.

No. 26,896. Medical Compound for the Cure of Whooping Cough, Bronchitis, Colds, Consumption and Diarrhoea. (Composition Médicinale pour la Coqueluche, les Bronchites, le Rhume, la Consommation et la diarrhée.)

Adolphe Derbuin, St. Henri de Montreal, Que., 7th June, 1887; 5 years.

Claim.—The herein described medical compound to be used for the cure of Whooping Cough, Bronchitis, Colds, Consumption and Diarrhoea, consisting of high wines, honey and coal tar in the proportions specified.

No. 26,897. Snow Plough. (*Charrue à Neige.*)

Almeran Roberts, Hanover, Me., U.S., 7th June, 1887; 5 years.

Claim.—1st. In a snow plow, the combination of series of adjustable scrapers arranged to direct the snow toward or away from the center of the road according to their adjustment, a triangular scraper carried behind the series of adjustable scrapers, and a guide runner for determining the direction of the plow, substantially as described. 2nd. In a snow plow, the combination of the guide runner D, the adjustable scrapers C, the scrapers E and the adjustable road-former B, substantially as described. 3rd. In a snow plow, the combination with the adjustable scrapers C₁ and the scrapers E, of the guide runner D provided with the shaft K, the cross bar e supported by the shaft K the windlass shaft a and the chains g, substantially as described. 4th. In a snow plow, the combination of the adjustable scrapers C₁, the scrapers E the road-former B₁₁₁ pivotally connected with the scrapers E, the windlasses a₁₁ and chains e for adjusting the road-former, substantially as described. 5th. The combination, in a snow plow, of the frame formed of the timbers A, A₁ crossing each other at right angles, the timbers B, B₁ secured to the ends of the timbers A, the frame A₁ supported by the timber B, the inverted arch D₁, the runner D, the shaft K attached thereto and provided with the collar K₁, the cross-bar e, the windlass shaft a, chains g, the adjustable scrapers C₁, ratchets a₁, pawls b and the fixed scrapers E substantially as described.

No. 26,898. Oil Cup for Supplying Oil or Grease to Rubbing Surfaces. (*Gôlet à Huile pour Distribuer l'huile ou la Graisse sur les Surfaces Frottantes.*)

Luther B. Bailey, London, Ont., 7th June, 1887; 5 years.

Claim.—1st. A cover C formed with a flange D, or its substantial equivalent on the inside, or on the outside or on both sides of the lubricant reservoir to lock and securely hold the cover in place when properly adjusted, substantially as described. 2nd. In a lubricator or oil-cup, a cover C formed with a flange D, in combination with a lubricant reservoir A formed with a passage B, substantially as described and for the purpose specified. 3rd. In a lubricator or oil cup, a spring F, or its substantial equivalent, for the purpose of tightly compressing the cover C on the sides of the lubricant reservoir A, substantially as described. 4th. A spring F and cover C, in combination with a stud pin E formed with shoulders E₁, and a lubricant reservoir A, substantially as described and for the purpose specified. 5th. In a lubricator or oil cup, a stud pin E or its substantial equivalent formed with shoulders E₂ for the purpose of rigidly binding said stud pin to the body A of a lubricant reservoir, to prevent its displacement when revolving the cover or from any cause whatever, substantially as described. 6th. The body A having a passage B, in combination with cover C formed with flange D, stud pin E formed with shoulders E₁, E₂, spring F and case G, substantially as described and for the purpose specified.

No. 26,899. Hot Air Furnace. (*Calorifère à Air.*)

Thomas McCrossan, Winnipeg, Man., 6th June, 1887; 5 years.

Claim.—The hollow door 12 having draft aperture H at the top, and draft aperture I on the inside, in combination with a furnace having a recessed door way, and an air chamber 7 above the fire box provided with an aperture coinciding with the aperture in the door, as set forth. 2nd. The combination, with the hollow door 12 having an inlet from an upper air chamber, and an outlet into the fire box of the dampers J, K, sliding in grooves at the top of the door, as set forth. 3rd. The combination, with the air chamber 4, of the catch pans d, e, as set forth. 4th. The combination, with the air chamber 7, of the catch pans d, e, as set forth.

No. 26,900. Gate. (*Barrière.*)

Philip S. Bassett, Bassett, W.V., U.S., 7th June, 1887; 5 years.

Claim.—1st. In a sliding gate, a guide-rod or guide-bar for supporting the gate, made in two parts or sections hooked together at their inner ends, and means for supporting said ends at any desired height, so arranged that one of said sections may be lifted or removed when the gate is open so as to be out of the way of a load passing through the gate, the outer ends of the said rods being screw-threaded, and a nut fitting on each of said screw-threaded ends, as and for the purpose shown and set forth. 2nd. In a sliding gate, the combination of a track rod extended across the gate-way and to one side of the same, and having the said extended portion inclined towards the gateway, with a gate having rollers or pulleys travelling upon the said track-rod, as and for the purpose shown and set forth. 3rd. In a sliding gate, the combination of a track-rod extended across the gate aperture, and having a screw-threaded end upon an extension at the side of the gate-aperture, a post having a vertical slot and placed to one side of the gate-aperture, having the screw-threaded end of the track-rod sliding in the slot, a gate travelling with rollers or pulleys upon the track-rod, and a thumb-nut upon the screw-threaded end of the rod for adjusting the said end in the slot of the post, and adjusting the angle of the extended portion of the track-rod, as and for the purpose shown and set forth. 4th. In a sliding gate, the combination of a track-rod secured across the gate-aperture and having an extension to one side of the said aperture, placed at an incline toward the gate-aperture, horizontally journalled pairs of pulleys or sheaves upon the top of the main-post and upon a post to the rear of the main post, posts at the side of the road-way at both sides of the gate, having vertically journalled pulleys or sheaves at their tops, a gate travelling with grooved pulleys or rollers upon the track-rod, and ropes or chains secured to the inner hanger of the gate, and passing in opposite directions over the sheaves upon the rear post, and thereupon over the sheaves upon the main post, and over the pulleys upon the posts at the side of the road-way, as and for the purpose shown and set forth.

No. 26,901. Triplicate Mirror. (*Miroir triple.*)

Peter Wiederer, Stapleton, N.Y., U.S., 7th June, 1887; 5 years.

Claim.—The combination of a main frame having a mirror supported at the back of the frame, said frame having detachable top and bottom pieces, folding side-frames having mirrors and eye-clips at their upper and lower corners, and fixed pintles passing through the top and bottom pieces, and eye-clips into sockets in the side-pieces of the main-frame, substantially as set forth.

No. 26,902. Erasive Guard for Writing Pencils. (*Garde de crayon pour effacer.*)

Walter K. Foster, Stoneham, Mass., U.S., 7th June, 1887; 5 years.

Claim.—1st. As a new or improved article of manufacture, the writing pencil erasive guard, substantially as described, composed of the elastic tube, the erasive prism or part, and the tapering or conical tubular projection, or point arranged and formed in one piece of india-rubber or other suitable elastic erasive material, it being for use upon a pencil for the protection of its point and otherwise, as specified. 2nd. The combination of a writing pencil, and an elastic erasive guard, substantially as described, applied to its body, and pointed portion, and extending a short distance rearward from the latter, as represented. 3rd. The combination of a writing pen and its holder, with the elastic erasive guard as and applied to them, substantially as set forth.

No. 26,903. Vehicle Spring. (*Ressort de voiture.*)

John J. Wolfe, West Millville, Penn., U.S., 7th June, 1887; 5 years.

Claim.—1st. In a vehicle-spring support, the combination, with two pairs of spring-rods formed with straight longitudinal central portions, outwardly-bent portions coiled at their inner ends, and forwardly and rearwardly bent portions secured to the axle and bolster, on a coupling and frame secured to the central straight portions, and having eyes for the outer portions of the outwardly bent portions, as and for the purpose shown and set forth. 2nd. In a vehicle-spring support, the combination of the axles and bolster, two pairs of spring-rods secured at their ends to the rear axle and to the bolster, formed at their middles into straight portions bent outward and coiled at the inner ends of the said bent portions, and bent to project forward and rearward, coupling rods secured at their ends to the vehicle-body, and formed with eyes for the reception of the transverse straight portions of the springs, transverse frame-rods having their ends secured to the vehicle-body and formed with eyes for the straight transverse portions of the springs doubled over the middle portions of the coupling-rods, and having their middles depressed and secured at the inclined ends of the depressed portions to the longitudinal middle portions of the springs, and rods secured with their forward ends to the middle portions or the coupling-rods, and having their rear eyed ends sliding upon the inner ends of the rearwardly projecting portions of the outer pair of springs, as and for the purpose shown and set forth.

No. 26,904. Water Wheel. (*Roue hydraulique.*)

Adolph Patrick, Maskinongé, Que., 7th June, 1887; 5 years.

Réclame.—1o. La combinaison, dans une roue hydraulique dite turbine, des aubes verticales L placées entre le fond K et le cylindre du milieu M, avec l'angle O d'écoulement de bus en haut fixés au cylindre du milieu M et entourés de la parois extérieure N, tel qu'indiqué et décrit et pour les fins mentionnées. 2o. La combinaison, dans un coffre de turbine, de conduits d₁ situés et fixés entre le plancher D et le rebord G, avec les pelles H pivotant entre le plancher et le rebord, et mues par des tiges et, l'anneau I, le collier J, les consoles g₁, le bras h, la crémaillère i, l'engrenage j, et l'arbre k, tel qu'indiqué et décrit et pour les fins mentionnées.

No. 26,905. Heating Apparatus for Railway Cars. (*Calorifère pour chars de chemins de fer.*)

Mann's Boudoir Car Company, (assignee of William D. Mann,) New York, N.Y., U.S., 8th June, 1887; 5 years.

Claim.—1st. A heating apparatus for railway cars consisting of the heater proper, and means in connection therewith for supplying hot water to a system of pipes for warming the car, combined with a fresh water tank, pipes conveying said water to a coil or equivalent device surrounding the fire chamber of the heater, and a service pipe for supplying hot water therefrom to the lavatories or other parts of the car, all substantially as described and shown. 2nd. A hot water apparatus for railway cars, consisting of a stove or heater, a coil surrounding same, a tank for containing fresh water connected with said coil, and a service pipe connected with the coil and tank, and extending through the car so as to be tapped at different points where hot water may be required, substantially as described and shown.

No. 26,906. Stays for Garments such as Corsets, Dresses, etc. (*Buse pour corsets, robes, etc.*)

Enoch C. Bowling and Henry P. Glover, Ypsilanti, Mich., U.S., 8th June, 1887 5 years.

Claim.—1st. The stay herein described comprising the stiffening-blade D, having sheets of gutta-percha tissue lying upon each side thereof and projecting over the ends and edges of said blade, with the covering fabrics having a like projection and adhering thereto, whereby a stitching edge is provided surrounding the stiffening-blade, as and for the purposes set forth. 2nd. A stay comprising a stiffening-blade having a textile fabric covering with interposed impervious coating, the parts adhering together and having the textile fabric stitching edges i, i, substantially as specified.

No. 26,907. Machine for Grinding Planing Machine Knives. (*Machine à rémouler les fers des machines à raboter.*)

William F. Steinhoff, Simcoe, Ont., 8th June, 1887; 5 years.

Claim.—1st. The combination of the double rimmed wheel B, paper friction rollers D, eccentric and arm I, substantially as and for the purpose hereinbefore set forth. 2nd. The combination, with the double rimmed wheel B, pulley D, eccentric C, cord E, arms J, J and K, stops M, quarter circle G, arm and weight H, substantially as and for the purpose hereinbefore set forth.

No. 26,908. Lock Nut. (*Arrête-écrou.*)

Armand Flamache and Emile Picard, Brussels, Belgium, 8th June, 1887; 5 years.

Claim.—1st. The combination of parts forming a nut and its washer, the contiguous surfaces of which are cut in helicoidal inclined planes of inclination exceeding that of the thread of the nut, so as to prevent the latter from becoming unscrewed. 2nd. The improved washer placed under the nut, and having a helicoidal inclined plane corresponding to that of the nut, but arranged so that it can be turned by means of a suitable key for the purpose of releasing the nut. 3rd. In screw-bolt fittings, the nut and washer of which have their contiguous surfaces arranged in helicoidal inclined planes either straight or coned, a radially split washer acting as a clip on the bolt, the lower surface of which may be slightly dished. 4th. The hereinbefore described system of bolts and nuts, having coned contiguous surfaces in place of straight inclined plane surfaces. 5th. The combination of parts consisting of a nut and its washer, the latter having an inclined plane surface of a pitch less than that of the thread of the nut for the purpose of augmenting the grip, as desired. 6th. The replacement of the inclined planes above described and claimed in claim 5, by screw threads.

No. 26,909. Apparatus for Lighting and Heating Railway Cars, etc. (*Appareil d'éclairage et de chauffage des chars de chemin de fer, etc.*)

Reuben H. Plass, New York, N.Y., U.S., 8th June, 1887; 5 years.

Claim.—1st. The means herein described for lighting and heating comprising a carburetor with suitable pipes leading thereto and therefrom, an air or gas forcing or exhausting apparatus connected with said carburetor, the heating apparatus and burners for lighting and also for supplying a gas-fuel or fuel-gas to the heating apparatus connected with pipes leading from the carburetor to supply said burners, and valves in said pipes, all substantially as and operated as set forth. 2nd. The means herein described for lighting and heating comprising the spring-motor, the diaphragm air-pump provided with a meter in its inlet opening, the pressure-regulator and the generator connected to each other and to the air and gas-pipes, substantially as specified. 3rd. The combination, with the nest spring-motor, consisting of springs coiled in separate sleeves and connected to common shafts to operate independently and in unison, of a spring-actuated clutch to retain power on the motor in winding up the springs, the diaphragm air-pump provided with a registering index or meter in its inlet-chamber, the pressure regulator and the generators connected to each other and to the air and gas-pipes, substantially as described. 4th. The means herein described for lighting and heating, comprising a spring-actuated motor, the diaphragm air-pump and the generators provided with air and gas-pipes having cocks, whereby one or both may be used, substantially as described. 5th. The combination of the spring-motor, the diaphragm air-pump, the pressure-regulator, the generators connected to the air and gas-pipes and the commingling-chamber, substantially as described. 6th. The combination, with the nest spring-motor, of the diaphragm air-pump having a meter in its inlet-chamber, the pressure-regulator generators connected to the gas and air pipe, the density-regulator and the commingling-chamber, substantially as described. 7th. The combination, with a car-body of the casing provided with non-conducting packing, of the generators provided with air and gas pipes, and the heating-pipes arranged within the casing and connected with the heating apparatus, substantially as described. 8th. The combination, with the car-body, of the casing provided with non-conducting packing, a coil of pipe in said casing connected with the heating-pipes of the car, and the generators or carburetors located in the casing and having the air and gas pipes and the coupling-pipes, substantially as described. 9th. The combination, in an apparatus for heating and lighting railway cars, of the spring-motor, the diaphragm air-pump, the interchangeable generators, air-pipes leading to the generators, the heating apparatus and pipe and gas-pipes leading from the generators to the heating apparatus, substantially as described. 10th. The combination, in an apparatus for heating and lighting railway-cars, of the spring-motor, the diaphragm air-pump, the generator situated in a casing provided with non-conducting packing, the heating apparatus, gas-pipe leading from the generator to the heating apparatus, and a pipe leading from the heating apparatus and coiled within the casing of the generator, substantially as described. 11th. The combination, in an apparatus for heating and lighting railway cars, of the spring-motor, the diaphragm air-pump, the generator air-pipes connecting the air-pump and generator, the heating apparatus and gas-pipes for conducting the gas to the car and heating apparatus, and provided with a safety-cock whereby the supply of gas is automatically cut off when the car is overturned.

No. 26,910. Traction Engine. (Road Engine.) (*Machine locomotive. Locomotive routière.*)

George T. Glover, Chicago, Ill., U.S., 8th June, 1887; 5 years.

Claim.—1st. In a traction or road engine, the engine-truck carrying an engine and provided with a sprocket which is driven from the engine, in combination with a propelling attachment jointed to or

flexibly connected with the engine truck, and provided with a sprocket which is in connection with the traction wheels, and which stands higher than the sprocket of the engine truck, said two sprockets being connected together by a chain or link belt, substantially as described, whereby when the traction wheels of the propelling attachment are driven through the medium of the chain and sprockets in a direction to advance the engine truck, the traction of said traction wheels shall be increased, substantially in the manner set forth. 2nd. In a traction or road engine, the engine-truck carrying an engine and provided with the sprocket E driven from said engine, in combination with the separate propelling attachment constructed with a pair of traction wheels, horizontal arms *f* extending forward from the axle of said wheel and jointed to the engine-truck and the sprocket *f* mounted between the wheels of the propelling attachment and standing higher than the sprocket E of the engine-truck, substantially as set forth, the two sprockets being connected by a chain belt which inclines downwardly from the upper portion of the sprocket of the propelling attachment to the upper portion of the sprocket of the engine-truck, whereby, when the traction wheels of the propelling attachment are driven through the medium of the chain and sprockets in a direction to advance the engine-truck, the traction of said traction wheels shall be increased proportionally to the weight of the engine-truck, and the opposition thereof to the forward movement of the propelling attachment. 3rd. The engine-truck, provided with an engine, in combination with the traction propelling attachment provided with forwardly-extending arms or side-bars, which extend along the sides of the engine-truck and are pivotally jointed thereto, said propelling attachment being driven from the engine, substantially as described. 4th. The combination, with the engine-truck provided with an engine, of the propelling attachment driven from the engine and jointed to the engine-truck by arms which are also adjustably connected with the engine-truck, whereby the endless chain belt employed to transmit power from a power transmitting mechanism on the engine-truck to the traction wheels of the traction-propelling attachment may be kept taut, substantially as described. 5th. The combination, with the propelling attachment jointed to the engine-truck and driven from an engine on the latter, of means for raising one end portion of the engine-truck and transferring the weight of the same to the propelling attachment, substantially as described. 6th. The combination, with the propelling attachment jointed to the engine-truck, and driven from an engine on the latter, of the steam-actuated piston connected with an end portion of the engine-truck, and operated in a cylinder which is supported from the propelling attachment, substantially as described. 7th. The traction propelling attachment jointed to the engine-truck, and driven from an engine on the latter, combined with a steam-actuated piston, and means whereby the action of said piston shall raise an end portion of the engine-truck, and transfer the weight thereof to the propelling attachment, substantially as described. 8th. The combination, with a propelling attachment jointed to an engine-truck and driven from the engine on the latter, of the steam-actuated piston connected with the engine-truck, and operative in a cylinder which is supported upon the propelling attachment by a jointed connection, substantially as described. 9th. In a traction engine adapted for use, more particularly on ice or snow roads, the steam pipe or pipes disposed to discharge the steam in a manner whereby the road shall receive the water of condensation for purposes of repair, substantially as described. 10th. A traction engine, for the purpose described, provided with one or more steam pipes or pipes arranged to discharge the steam against the propelling traction wheel or wheels, substantially as set forth, and the traction-propelling attachment connected with the engine-truck and driven from the engine, combined with a hood or casing which encloses the traction-propelling wheels and the discharge portion of the steam pipes, for the purposes specified. 11th. A traction engine provided with a hood or casing constituting an open bottom chamber arranged over the road, and one or more steam pipes which discharge in said chamber, substantially as specified. 12th. The combination, with a traction engine for the purpose set forth, of a steering apparatus comprising an endless chain belt supported upon sprockets, means for operating the same, and a jointed connection between said chain belt and the forward pair of wheels or runners, substantially as described. 13th. The combination, with a traction engine, for the purpose described, of a chain belt supported upon sprockets and carrying a socket piece R, in which a tongue or pole connected with the forward wheels or runners is received, substantially as specified. 14th. The engine-truck, carrying an engine and a traction propelling attachment connected with the engine truck and driven from the engine, in combination with a steering attachment applied to the engine truck, substantially as set forth. 15th. The combination, with the engine shaft, of the counter-shaft driven therefrom, a worm sleeve keyed to the counter-shaft to rotate therewith, but to slide thereon, with an end movement, stops for limiting the extent of slide of the worm sleeve, and a gear engaged and driven by the worm sleeve, substantially as described. 16th. The combination, with the traction-propelling attachment jointed to the engine-truck carrying an engine, said propelling attachment being provided with a frame or arms extending back from its axle, whereby a sled may be attached to the propelling attachment in rear of the traction propelling wheels, substantially as described. 17th. In a traction engine, the traction wheels provided with removable teeth, substantially as set forth. 18th. In a traction engine, the traction-wheel provided with removable teeth S, which are concaved to fit the curved perimeter of the traction wheel, as set forth. 19th. The combination, with the traction wheels in a traction engine, adapted for running over snow or ice roads, of the steam pipe or pipes adapted to direct the steam against said traction wheels, so as to heat the same, substantially as described.

No. 26,911. Vent Faucet for Bottles.

(*Bouchon à soupape pour bouteilles.*)

Michael H. Hagarty (assignee of Frank McArdle, Brooklyn, N. Y., U.S., 8th June, 1887; 5 years.

Claim.—1st. The combination, with the cap or casing A, having the lateral discharge opening *d*, of the horizontally reciprocating valve 10 for controlling the same, the valve stem 20 extending outward

through the side of the cap opposite the opening *d*, and the lever *D* fulcrumed on the side of the cap and engaging with the valve stem 20, substantially as described. 2nd. The combination, with the cap or casing *A*, having the lateral discharge and vent openings, of the horizontally reciprocating valves 10, 8 for controlling the same, the valve stems 20, 7, extending outward through the same side of the cap, and the lever *D* fulcrumed on the side of the cap and engaging with the valve stems 20 to open both of the valves, substantially as described. 3rd. The combination, with the cap or casing *A*, having the lateral discharge opening *d*, of the horizontally reciprocating valve 10 for controlling the same, the valve stem 20 extending outward through the side of the cap opposite the opening *d*, the lever *D* fulcrumed on the side of the cap and engaging with the valve stem 20 to open the valve and the spring 17 for closing the valve, substantially as described. 4th. The combination, with the cap or casing *A* having the discharge opening *d* and cylinder *e*, of the valve 10 and valve stem 20 having the piston 13 whereby the valve is balanced, substantially as described. 5th. The combination, with the cap or casing *A*, having the discharge opening *d* and cylinder *e*, of the valve 10, the valve stem 20 having the piston 13, the lever *D* for opening the valve and a spring for closing the same, substantially as described. 6th. The combination, with the cap or casing *A* having the discharge opening *d* and cylinder *e*, of the valve 10 and the valve stem 20, having the piston 12 provided with the cup-shaped packing 15, substantially as described. 7th. The combination, with the cap or casing *A* having the discharge opening *d* and cylinder *e*, of the valve 10, valve stem 20, having the piston 13, cup-shaped packing 15 and sleeve 16, substantially as described. 8th. The combination, with the cap or casing *A*, having the discharge and vent openings *d*, *i*, and cylinder *e*, of the valves 108, springs 17, 6, piston 13 and lever *D*, substantially as described.

No. 26,912. Harrow. (*Herse*.)

Eliza A. Callander (assignee of Austin Callander), Smith's Falls, Ont., 8th June, 1887; 5 years.

Claim.—1st. A harrow clip, consisting of a casing covering mortises, admitting and holding the bulls and tooth, and composed of a main body tapering internally and externally, and of a loose section engaged and held by the tooth and impinging against the bulls, substantially as set forth. 2nd. The combination of the sections *C* and *C*₁ and mortises *a*, *b*, *b*₁, substantially as set forth. 3rd. The combination of the loose section *C*₁, main section *C* and mortise lug *d*, substantially as set forth. 4th. The combination, in a harrow, of the bulls *B*, *B*₁, clips *C* having loose sections *C*₁, teeth *A*, bars *B*₁ and clips *D*, substantially as set forth. 5th. The combination of the clip section *C*, mortise *a* and joined spaces for the mortises *b* and *b*₁, substantially as set forth. 6th. The combination of the section *C*, top *c*, cheek *c*₁ and mortise *a*, substantially as set forth.

No. 26,913. Sewer Ventilator.

(*Ventilateur d'égout*.)

William H. McAndrews and Albert M. Gerstle, Youngstown, Ohio, N.S., 8th June, 1887; 5 years.

Claim.—1st. In a sewer ventilator, the expansion chamber *A* of any suitable form and dimension, with a proper escape pipe from the ventilator for the purpose of receiving condensed sewer gases, and permitting the expansion of the same above the fresh air inlet *D* to create a more rapid escape of the gases through *C*, thereby increasing the inflow and movement of air through *D* into the sewer, substantially as described and for the purpose expressed. 2nd. In sewer ventilators, the fresh air inlet *D* and the gas-escape pipe *C* in a trapless sewer or lateral, substantially as described and for the purpose expressed. 3rd. In a trapless sewer or lateral, the ventilator, consisting of the *A*, the escape pipe *C* and the air inlet *D* forming a gas check, while also introducing the air below the sewer gas, substantially as described and for the purpose expressed.

No. 26,914. Nut Lock. (*Arrête-écrou*.)

Orlando L. Castle, Upper Alton, Ill., Marshall Arnold and Rodney J. Hudson, Lakeport, Cal., U.S., 8th June, 1887; 5 years.

Claim.—A nut holder *A*, provided at each end and on opposite sides of the nuts to be held with a washer *B* and *B*₁ respectively, with one of which it is connected by means of a hinge *H*, and with the other by means of a clutch *H*₁ and hook *h*, substantially as described and for the purposes herein set forth.

No. 26,915. Earth Auger. (*Sonde à tarière*.)

Henry Iwan and Louis Iwan, Streator, Ill., U. S., 10th June, 1887; 5 years.

Claim.—1st. An earth auger, having blades provided with downward and laterally cutting bits, substantially as described. 2nd. An earth auger, having blades provided with downward and laterally cutting chamfered bits, substantially as described. 3rd. An earth auger, having blades provided with downward-cutting chamfered bits, and laterally-cutting chamfered bits, substantially as described. 4th. An earth auger, having chamfered blades provided with downward cutting chamfered bits, and laterally-cutting chamfered slanting bits, substantially as described. 5th. An earth auger, having blades *A*, provided with bits *q* and *p*, substantially as and for the purpose set forth. 6th. An earth auger, having a yoke *r* upon its stem *B*, blades *A* secured upon the yoke and provided with bits *q* and *p*, substantially as and for the purpose set forth. 7th. An earth auger, comprising in combination a stem *B*, provided with a handle *C* and yoke *r*, converging chamfered blades *A* secured to the yoke, and downward-cutting bits *q*, and laterally-cutting slanting bits *p* extending from the lower extremities of the blades, substantially as and for the purpose set forth.

No. 26,916. Baling Press. (*Presse d'emballage*.)

George Ertel, Quincy, Ill., U.S., 10th June, 1887; 5 years.

Claim.—1st. The combination, with the press case and a plunger

fitted therein, of a roller or rollers placed loosely between the plunger and the floor of the case, substantially as described for the purposes set forth. 2nd. The combination, with the press case and a plunger fitted therein and provided with grooves, as *f*, in its lower surface, of a roller or rollers placed loosely in said grooves on the floor of the case, substantially as described for the purpose set forth. 3rd. The combination, with the press case, a plunger, as *D*, fitted therein, and rollers, as *F*, placed loosely between the plunger and the floor of the case, of removable roller retainers, as *f*, fitted in the plunger, substantially as shown and described. 4th. The combination, with the press case, a plunger, as *D*, fitted therein, and having roller ways or guides at its lower surface, of rollers, as *F*, placed loosely between the plunger and the floor of the case, and said plunger provided with openings *d*₃, through which the rollers may be removed, substantially as shown and described. 5th. The combination, with the press case, a plunger, as *D*, fitted therein, and loose rollers, as *F*, placed beneath the plunger, substantially as specified, of a clamp or brake device fitted to the top of the press case, substantially as described, whereby as the plunger overbalances backward on the loose rollers it will be forced by said clamp or brake to the floor of the press case, as and for the purpose set forth. 6th. The combination, with the press case, a plunger, as *D*, fitted therein, and loose rollers as *F*, placed beneath the plunger, substantially as specified, of a clamping device fitted to the top of the press case, and comprising a brake lever *E*, hung to the case, and provided with inclined and flat clamp faces adapted to corresponding plates on the plunger and a pressure regulating fulcrum *E*₁ to said lever, substantially as described for the purposes set forth. 7th. The combination, with the press case, a plunger, as *D*, fitted therein, and loose rollers, as *F*, placed beneath the plunger, substantially as specified, of a resistance bar placed at the rear end of the baling box feed opening, substantially as described, whereby as the plunger approaches the limit of its forward stroke it will, while overbalanced forward on the rollers, be forced by the resistance bar to the floor of the press case to relieve the rollers of excessive pressure, substantially as herein set forth. 8th. The combination, with the press case, a plunger, as *D*, fitted therein, and loose rollers, as *F*, placed beneath the plunger, substantially as specified, of a pivoted folder positioned at the rear end of the baling box feed opening, substantially as shown and described, whereby the folder will force the forwardly overbalanced plunger to the floor of the press case, and will simultaneously fold the material being pressed within the baling box, as and for the purposes set forth. 9th. The combination, with the press case, of a folder *G* pivoted at the rear end of the baling box feed opening, and provided with an outer face *g*₂, which folds the material being baled, and an inner or forward face *g*₁ coating with the press frame or lip thereon to prevent passage of the material between the folder and the press frame, substantially as shown and described. 10th. The combination, with the press case, of a folder *G* pivoted at the rear end of the baling box feed opening, and formed with faces *g*₂, *g*₁, and a lip, *g*₃, at the apex of the angle formed by said faces, substantially shown and described. 11th. The combination, with the press case, of a folder *G* pivoted at the rear end of the baling box feed opening, and formed with faces *g*₂, *g*₁, and a lip, *g*₃, adapted to stop against the press case or a lip thereon, substantially as shown and described. 12th. The combination, with the press case, of a folder *G* pivoted at the rear end of the baling box feed opening, and formed with faces *g*₂, *g*₁, and lips, *g*₄, *g*₃, said lips adapted to stop against the press frame or a lip thereon, substantially as shown and described. 13th. The combination, with the press case, of a folder *G* pivoted at the rear end of the baling box feed opening, and formed with faces *g*₂, *g*₁, and lips, *g*₄, *g*₃, adapted to stop against the press frame or a lip thereon, and springs *I* normally turning the folder downward, substantially as shown and described. 14th. The combination, with the press case, of a folder *G* pivoted at the rear end of the baling box feed opening, and formed with faces *g*₂, *g*₁, and operating substantially as specified, and a wear plate *H*, fitted to the case next the folder, and provided with an inclined face *h*₂, and a lip *h*₃, substantially as described for the purposes set forth. 15th. In a baling press, the combination, with the press case having a feed opening, of a platform provided with an opening to admit the body of the feeder or attendant near the feed opening of the press, substantially as described for the purposes set forth. 16th. The combination, with the press frame, of a feeder platform *N* attached at one edge to the frame next the baling box, and provided with an opening as *O* to admit the body of the attendant, and braces *P* sustaining the platform from the press frame, substantially as shown and described. 17th. A baling press, constructed with side linings of its baling box supported yieldingly or elastically at the rear end of said box, substantially as shown and described. 18th. A baling press constructed with side linings *R*, *R* of its baling box made to yield at the rear end of said box, combined with suitable timber supports or backing and bolts *6*, nuts *7*, and springs *9*, substantially as described. 19th. A baling press constructed with the rear portion of its baling box, formed with two opposite walls supported yieldingly or elastically, and with its other two opposite walls fixed rigidly in positions to reduce the size of the baling box from the feed opening to the extreme rear end of the box, substantially as described for the purposes set forth. 20th. A baling press constructed with a frame, side walls or linings *R*, *R*, held thereto and adapted to yield at their rear ends, backings to said linings, bolts *6*, nuts *7*, and springs *9*, substantially as specified and top and bottom linings *V*, *V*, having forward parts *v*, *v* extending into the baling box and fixed in positions to reduce the depth of the box from its feed opening to its rear end by means of backing timbers *15*, *16*, and nutted bolts *17*, substantially as shown and described. 21st. A baling press constructed with a bale chamber *C* formed by corner timbers *A* and two opposite linings held thereto, and springs fitted to the chamber walls, to cause yielding pressure of the walls on the material being baled, substantially as herein set forth. 22nd. A baling press constructed with a bale chamber *C* formed by corner timbers *A*, and two opposite linings held thereto opposite timbers *19* fitted loosely in the timbers *A*, and springs fitted to the chamber walls to cause yielding pressure of the walls on the material being baled, substantially as herein set forth. 23rd. A baling press constructed with a bale chamber *C* formed by corner timbers *A*, and two opposite linings held thereto, in combination with cross bars or timbers arranged at the linings or walls of the press frame, bolts, as

W, *u*, fitted to said cross bars, and a spring or springs X, substantially as herein set forth. 24th. A baling press constructed with a bale chamber C formed by corner timbers A, and two opposite linings held thereto opposite timbers 19 fitted loosely in the timbers A, cross bars or timbers arranged at the linings or walls of the press frame, bolts, as W, *u*, fitted to said cross bars, and a spring or springs X, substantially as herein set forth. 25th. A baling press constructed with opposite pairs of cross timbers 11, 12, 13, 14, framed to the corner timbers of the press, and the inner faces of the cross timbers dressed off, whereby when linings V, U are secured to them the bale chamber will be enlarged from front to rear, substantially as herein set forth. 26th. A baling press constructed with opposite pairs of frame timbers 10, 11, 12, 13, and 14, those 11 being thickest, and those 10 in front of them made thinner, and those 12, 13, 14, in rear of the 11 being successively thinner toward the rear end of the press, substantially as shown and described, whereby the parts *u*, *v* of the linings U, V fixed to the timbers 10 and 11, and forming side walls to the baling box, will diverge towards the plunger, and the rear parts of the linings fixed to the timbers 11, 12, 13, and 14, will diverge toward the rear end of the bale chamber, substantially as herein set forth.

No. 26,917. Harrow and Cultivator. (Herse-scarificateur)

James G. Bailey, Richmond Hill, Ont., 10th June, 1887; 5 years.

Claim.—1st. A cultivator or harrow frame composed of light metal bars A, having lips *a* formed on their edges, in combination with the cross-block B, fitted between the lips of said bars at their point of intersection, and adapted to make the frame rigid and form a bearing for the bolt which binds the saddle to the frame, as and for the purpose specified. 2nd. A cultivator or harrow frame, composed of bars A, having lips *a* formed on one side thereof, and block B, having lips *b*, between which the upper bar of the frame rests, and adapted to make the frame rigid and form a bearing for the bolt which binds the saddle to the frame, substantially as and for the purpose specified. 3rd. The frame or bar A having lips *a* formed on its edges, in combination with a bevelled block or saddle fitted between the said lips and forming a seat for the tooth E, in combination with the said lips or lugs *c* and the bolt C, substantially as and for the purpose specified. 4th. The frame or bar A, having lips *a* formed on its edges between which the saddle D is placed, in combination with the tooth E fitting between the jaws *d* formed on the saddle D, and the bolt C binding them to the frame, substantially as and for the purpose specified. 5th. The bar or frame A having lips *a* formed on its edges and the cross-block B, in combination with the saddle D, having the bottom shaped to fit between the said lips *a*, the tooth E fitted between the jaws *d* on the saddle D, and rigidly secured by means of the key F, substantially as and for the purpose specified. 6th. The frame A, with lips *a* formed on its edges, and having a cross-block B fitted between the lips on the bars forming said frame at their point of intersection, in combination with the saddle D having the bottom shaped to fit between said lips, together with the tooth E fitted between the jaws *d* on the saddle D, and rigidly secured to the frame by means of the bolt C, substantially as and for the purpose specified. 7th. The frame or bar A, having lips *a* formed on its edges between which the bottom of the saddle D fits, and the cross-block B, in combination with the wedge G, either detachable or solid with the saddle which is bolted to the frame and forms a seat for the tooth E, said tooth being secured in position by the key F, which passes through jaws *d* on said saddle, substantially as and for the purpose specified. 8th. The frame A having lips *a* formed on its edge between which the bottom of the saddle D fits, and the cross-block B fitted between said lips, in combination with the wedge G, either detachable or solid with the saddle D, said saddle forming a seat for the tooth E which is secured in position by the bolt C, substantially as specified. 9th. The frame A having lips formed on one side thereof, and the block B having lips *b* between which the upper bar of the frame rests, the saddle D having the bottom shaped to fit between the said lips *a*, the tooth E fitted between the jaws *d* on the saddle D, and secured in position by the key F, in combination with the wedge G, either detachable or solid with the saddle D, substantially as specified. 10th. The bar or frame A having lips *a* formed on its edges, in combination with the saddle D, having the bottom shaped to fit between the said lips *a*, and the tooth E fitted between the jaws *d* on the saddle D, and rigidly secured by means of the key F, substantially as described.

No. 26,918. Car Mover. (Levier de mise en marche.)

Elouild Duplessis, Lake Weedon, Que., 10th June, 1887; 5 years.

Claim.—1st. In a car mover, the combination of a lever having an inclined toothed end, with a lever pivoted near the said end, and formed into a hook having a serrated inner edge, and a spring held between the said levers, substantially as shown and described. 2nd. In a car mover, the lever A, the teeth C formed on the inclined end B of the said lever A, in combination with the lever E, the hook F formed on the said lever E, and having a serrated inner edge, and the spring G fastened to the one edge of the said lever E, and resting with its free end on one edge of the lever A, substantially as shown and described. 3rd. The herein described car mover, the lever A provided with the teeth C, the lever E pivoted to the end of the lever A and formed with the hook F at one end, and having its other end forked and connected by a cross bar, and a spring secured to the cross bar and resting with its free end against the lever A, as specified.

No. 26,919. Crib and Cradle for Children. (Berçonnelle-Berceau.)

James A. Gade, Stockholm Depot (assignee of Daniel W. Pettis, East Stockholm), N. Y., U.S., 11th June, 1887; 5 years.

Claim.—1st. A cradle or crib comprising a frame, rockers arranged in pairs and pivotally secured to the opposite sides or ends of the frame, and means substantially as described for connecting the pairs of rockers and the rockers of each pair, substantially as set forth. 2nd. In a cradle or crib, the combination of the frame having opposite side rails at its bottom, provided with slots equally distant from their ends, the rockers secured to rocker bars of equal length, and having their upper ends pivoted in said slots, and the bars connecting the opposite rocker bars on each side and connected together near their ends by loose rods or wires, substantially as specified. 3rd. The herein described crib composed of the frame A, having opposite rails at its bottom, provided with the slots *b*1, the rockers B, and rocker bars *b*, having their upper ends pivoted in said slots, the connecting bars C, the eye-bolts D secured to the inner surfaces of said bars, and the stiff wire rods *d*, having their ends hooked or engaged in the eyes of said bolts, all constructed and arranged, substantially as and for the purpose specified.

No. 26,920. Anti-Parasitic Apparatus.

(Appareil insecticide.)

Norris B. Peters and Minnie C. Peters, Troy, N. Y., U.S., 11th June, 1887; 5 years.

Claim.—1st. A water medicating apparatus, consisting of an air-tight vessel having its lower part lined with a non-corrodible substance, a supply-funnel provided with a cock, a cup supported upon a bracket and adapted to contain burning charcoal and sulphur, a glazed peep-hole, a stuffing-box adapted to receive through it an agitator and a draw-off pipe at the bottom of the vessel, substantially as described. 2nd. The combination, with an air-tight tank for the purposes described, having its lower portion lined with wood surrounded by an air-space, a draw-off pipe provided with a cock, a feed-funnel also provided with a cock, a furnace H, a glazed peep-hole and a hand-hole, substantially as described.

No. 26,921. Two-Wheeled Vehicle.

(Voiture à deux roues.)

Charles S. Beebe, Racine, Wis., U.S., 11th June, 1887; 5 years.

Claim.—1st. In a two-wheel vehicle, the springs thereof pivotally secured at their front ends to the cross-bar, and their rear ends loosely connected to the axle, and having a free longitudinal and lateral movement thereon, as set forth. 2nd. In a two-wheel vehicle, the springs thereof pivotally connected at their front ends to the cross-bar, and their rear ends turned up and carried back toward the front of said vehicle, whereby they come over and rest upon the axle, as set forth. 3rd. In a two-wheel vehicle, the springs thereof pivotally connected at their front ends to the cross-bar, and their rear ends turned up and carried back toward the front of said vehicle, whereby they come over and rest upon the axle, in combination with angle-irons secured to the shafts, and adapted to impinge against said rear ends of the springs, as set forth. 4th. In a two-wheel vehicle, the seat-bars thereof supported at the required elevation by angular brace-irons having their ends respectively secured to said bars, and the springs, as set forth. 5th. In a two-wheel vehicle, the seat-bars thereof pivotally connected at their forward ends to the springs, and supported by brace-irons that are rigidly connected to said bar and springs, as set forth. 6th. In a two-wheel vehicle, provided with angular brace-irons designed to connect the springs and seat-bars, whereby the latter are held at the desired elevation, each of said angle-irons having its lower end on the same horizontal plane as the spring to which it may be secured, and the upper end at an acute angle to said plane, as set forth. 7th. In a two-wheel vehicle, an angle-iron adapted to be fitted to a shaft, and provided with a projecting finger designed to come over an adjacent spring, whereby the latter is prevented from vertical displacement, as set forth. 8th. In a two-wheel vehicle, an angle-iron adapted to be fitted to a shaft with its base interposed between the latter, and the axle, and provided with a projecting finger designed to impinge against an adjacent spring, in combination with an angular strap secured to the under face of the shaft, and suitable bolts adapted to pass through the heads of the angle-iron, the shaft and angular strap, whereby the several parts are secured in position with relation to said axle, as set forth.

No. 26,922. Land Plough. (Charrue)

Hugh Johnston, Toronto, Ont., 11th June, 1887; 5 years.

Claim.—The combination of the elevation E1, with the point A, and coulter D, and beam C, and mould-board B, substantially as and for the purpose herein set forth.

No. 26,923. Surgical Instrument for Treating Suppurating Wounds. (Instrument de chirurgie pour le traitement des blessures suppurantes.)

Paul F. Francke, Chemnitz, Germany, 11th June, 1887; 5 years.

Claim.—A depurator or surgical instrument, consisting of a flexible core, made of a spirally-bent wire having an enlarged head and a coating of a medicated composition extending over the core and head, substantially as set forth.

No. 26,924. Manufacture of Plaster or Cement. (Fabrication du plâtre ou du ciment.)

John Tomlinson, Carlisle, Eng., 11th June, 1887; 5 years.

Claim.—A cement consisting of calcined and powdered gypsum, mixed with powdered tinoal, and with or without other ingredients, substantially as described.

No. 26,925. Manufacture of Sulphurous Acid and other Compounds of Sulphur, and Apparatus employed in such Manufacture.
(*Fabrication de l'acide sulphureux et autres compositions de soufre, et appareil pour cet objet.*)

Joseph M. Walton, Glossop, Derby, Eng., 11th June, 1887; 5 years.

Claim.—1st. The improvements in the manufacture of sulphurous acid, or of sulphites or bisulphites, from alkaline basis, consisting in causing the sulphurous acid gas to pass over the surface of the water or alkaline solution in suitable vats or vessels (kept about half full) whilst the said water or solution is maintained in a state of agitation, and is lifted and allowed to fall in a shower through the gas. 2nd. I claim the improved apparatus for such manufacture, consisting of series of vats or vessels provided with revolving agitators for keeping the water or alkaline solution which about half fills such vessels in a state of agitation, and lifting and dropping it, in the form of a shower, whilst the sulphurous acid gas passes through, the vats or vessels above the level of the liquid, substantially as hereinbefore particularly described and illustrated by the drawings annexed. 3rd. I claim in an apparatus for the manufacture of sulphurous acid, agitators *c, c* mounted on vertical axis *d, d*, and the combination therewith of pumps *h, h*, and distributors *k, k* for raising the liquid and distributing it in the form of a shower.

No. 26,926. System of Telephony.

(*Système de téléphonie.*)

William Burnley, North East, Penn., U. S., 11th June, 1887; 5 years.

Claim.—1st. The combination, with a microphonic or battery transmitter, and an inductorium having several secondary coils, of a condenser connected with said coils, the other terminals thereof being connected with the circuit of the telephonic receiver, and the primary coil of said inductorium being included in the transmitter battery circuit, substantially as described. 2nd. The combination of a diaphragm having a fixed electrode, a loose rolling or a sliding electrode co-operating with the diaphragm electrode, and an inclined platform having means, substantially as described, for adjusting or varying its inclination, as and for the purposes set forth. 3rd. The combination of the tilting metal plate or platform 14, and spring tongue 16 having notches 17, with the loose or rolling electrode and the diaphragm carrying a fixed electrode, substantially as described. 4th. In a telephone transmitter, the combination of two parallel electrodes, contacting throughout their length an inclined plane upon which one of said electrodes rests loosely so as to be capable of moving thereon while the other is attached to the diaphragm, and means for adjusting the inclination of said plane, substantially as described. 5th. In a telephone transmitter, the combination, with a ring supporting the diaphragm and having inclined slots 18, of an inclined plane 20 having pivots 19 and provided with lugs 21, substantially as set forth. 6th. In a telephone transmitter, the combination, with the diaphragm having an electrode and the frame or holder, of an inclined plane loose ballasted electrodes and vertical screw for supporting and adjusting the inclined plane, substantially as set forth.

No. 26,927. Manufacture of Wax Matches and Pipe and Cigar Lighters.

(*Fabrication des allumettes de cire et des allumettes de pipes et de cigares.*)

Richard Bell, New Wandsworth, Eng., 11th June, 1887; 5 years.

Claim.—1st. A combined match and fusee, consisting of a length of wax "taper" (composed of fibrous yarns, or strands coated with paraffine, wax, stearine, or equivalent material) provided with a fusee head of inflammable composition, made of chlorate of potash, flour, gum arabic, and amorphous phosphorus in the proportions mentioned, and tipped with a friction igniting composition, as described. 2nd. A combined match and fusee consisting of a length of wax "taper" having a metallic wire extending through it from end to end, and provided with a fusee head of inflammable composition tipped with a friction igniting composition, as described. 3rd. A wax vesta match consisting of a length of wax "taper", tipped with a deflagrating composition, as usual, and provided with one or more longitudinal wires, substantially as and for the purpose specified.

No. 26,928. Car-Coupling. (*Attelage de chars.*)

Charles W. Chisholm, Winnipeg, Man., 11th June, 1887; 5 years.

Claim.—1st. The combination, with a draw-head formed with a link recess and a slot leading thereto, of a coupling-dog mounted within said slot and formed with a shoulder 19 and a projection 20, substantially as described. 2nd. The combination, with a draw-head having a recess 22 and a slot 13, of a coupling-dog pivotally mounted within the slot, and arranged to enter the recess 22, said coupling-dog being provided with a shoulder 19 and a projection 20, substantially as described. 3rd. The combination, with a draw-head formed with a recess 22 and a slot 13, of a coupling-dog 16 mounted upon a pivot-pin or bolt and arranged to enter the recess 22, the coupling-dog being formed with a shoulder 19, a projection 20, a forward inclined face 9 and a projection 25 which extends outward beyond the draw-head, substantially as described. 4th. In a coupling, the combination, with a draw-head, of a coupling-dog pivotally mounted therein, and a cover 26 pivotally connected to the coupling-dog, substantially as described. 5th. In a coupling, the combination, with a draw-head, of a coupling-dog having inclined sides, said coupling-dog being mounted with a slot that is formed in the draw-head, substantially as described.

No. 26,929. Drop Door for Ovens.

(*Porte à bascule pour fourneaux.*)

Lucius L. Culver, St. Louis, Mo., U.S., 11th June, 1887; 5 years.

Claim.—The combination, with a stove having a door D hinged at bottom, of the brace rod G hinged at one extremity beneath said door, the guide-rod H hinged at one extremity to the free extremity of said brace-rod, and the eyes or staples I, secured to the door through which said guide-rod slides, substantially as set forth.

No. 26,930. Paper Box. (*Boîte de papier.*)

Seth H. Smith, Delta, Ohio, U.S., 11th June, 1887; 5 years.

Claim.—1st. A paper box having the ends provided with projecting perforated ears or tongues, and the top flaps having the openings to receive the said ears or tongues for the purpose set forth, substantially as described. 2nd. The paper box having the ears or tongues at its ends, and the top flaps having the openings to receive the said ears or tongues when the said flaps are folded over the top of the box, in combination with the bail having the arms extending through openings made in the ears or tongues, and thereby attach the bail to the box, and also lock the tops thereon, substantially as described. 3rd. The paper box having the tongues or ears at its ends, and the flaps having openings to receive the said ears or tongues when the said flaps are folded over the ends of the box, in combination with the bail to engage or lock with the said ears or tongues and thereby attach the bail to the box and also lock the flaps thereto, as set forth. 4th. A paper box or package made from a single sheet of material to form the sides, ends bottom and top flaps, the latter folding over the exposed edges of the ends B, and the continuous re-enforce strips D applied along such exposed edges of the ends, said re-enforce strips being made from a single piece of metal doubled longitudinally to form clamping sides to clasp the top flaps of the exposed edge of the paper sheet, and tongues (one or more) form d integral with the re-enforce strips which tongues engage the top flaps of the paper package or box, as set forth.

No. 26,931. Electric Motor. (*Moteur électrique.*)

The Baxter Electric Manufacturing and Motor Company (assignee of William Baxter, Jr.), Baltimore, Md., U.S., 13th June, 1887; 5 years.

Claim.—1st. In an electric motor, the combination, with two field magnets inclined toward one another, as described, of a bridge connecting the bases of the magnets and arched toward the magnetic field, as described, and provided with lugs *f* for sustaining the armature, substantially as shown and described. 2nd. In an electric motor, the combination, with two field magnets, inclined toward one another, as described, of the bridge *b* formed with two seats *b* in the same plane to receive the field magnets *a*, and arched in the middle toward the inner ends of the magnets, as and for the purpose set forth. 3rd. In an electric motor, the combination, with two field magnets, inclined toward one another, as described, of a bridge connecting the bases of the magnets, and arched toward the magnetic field, as described, and provided with the lugs *f*, sustaining posts *c* provided with bushings to form bearings for the armature spindle, as and for the purpose set forth. 4th. In an electric motor, the spindle bearing constructed, substantially as shown and described, and consisting in the post *c*, provided with bushing *e*, recess *c* surrounding the same, holes *e* connecting the interior of the bearing with said recess, and a screw plug *c* for replenishing or closing the recess, substantially as herein set forth. 5th. In an electric motor, the construction for the armature consisting in the collar *h* fixed upon the spindle at one end of the armature, the nut *k* fitted to a thread upon the spindle at the opposite end, the barrel *g* of non-conducting material, and the metallic disks *g* and the heads *g* pressed upon the disks by the rotation of the nut *k*, all substantially as herein shown and described. 6th. In an electric motor, the construction for the commutator, consisting in the sections *n* having bevelled ends *n*, secured upon the armature spindle or arbor by a thread formed upon the same, and by countersunk nuts *l* and *l* clamped upon the tapering ends of the sections by turning upon the screw thread, substantially as shown and described. 7th. In an electric motor, the combination with the ring *g* surrounding the brushes, and provided with the metallic linings *r*₃, in electrical connection respectively with the two field magnets of the brushes, provided each with a yielding spring *r*₁ adapted to bear elastically upon one of the linings *r*₃, as and for the purpose set forth. 8th. In an electric motor, the combination, with the ring *g* surrounding the brushes and provided with the metallic linings *r*₃ in electrical connection respectively with the two field magnets, of the brushes provided each with the shorter spring *r*₁ and the longer spring *r*₂, the two springs being adapted to bear elastically against the metallic linings *r*₃, and to form an electrical connection between the field magnets, when the brushes are in their inoperative position, as and for the purpose set forth. 9th. In an electric motor, the combination with the ring *g* surrounding the brushes and provided with the metallic linings *r*₃, in electrical connection respectively with the two field magnets, of the brushes pivoted by holders upon the arm *p*, the spring *s* affixed to the frame and operating to turn the arm and brushes to an imperative position, the springs *t* operating to press the brushes toward the commutator, levers *t* affixed to the brush blocks and projected at the side of the ring *g*, and stops *t*₂ upon such ring to check the levers and move the brushes away from the commutator when the arm is thrown into its inoperative position. 10th. In an electric motor, the combination, with two flat field magnets, having their flat sides inclined toward one another, as described, of a flat bridge connecting the bases of the magnets and arched toward the magnetic field, as and for the purpose set forth.

No. 26,932. Grain and Grass Seeder.

(*Semoir à grain et à graine.*)

George W. Kirkpatrick, Macon, N. Y., U. S., 13th June, 1887; 5 years.

Claim.—1st. In a seeding machine, the independently actuated

reciprocating cords or rods arranged to move in parallel lines, in combination with means for actuating said cords, substantially as described, whereby, where one cord is at or near the end of its throw, the other will be moving at speed, for the purpose, substantially as specified. 2nd. In a seeding machine, the hopper bottom provided with the parallel grooves, and the travelling cords or rods moving therein, in combination with the sector racks secured to and operating beneath the said hopper bottom, substantially as described. 3rd. In a seeding machine, the hopper bottom provided with parallel grooves, the cords or rods travelling therein, the rack plates carrying the said cords or rods, and the sector-racks, in combination with a gear wheel on the main axle of the machine, and the pinion disks and pitmen rods interposed between the said sector racks and gear wheel on the main axle, substantially as described. 4th. In a seeding machine, the combination, with a gear wheel mounted on the main axle, of a pinion gearing therewith mounted in a pivoted frame, disks secured to the shaft of said pinion, and adapted to rotate therewith for imparting motion to the travelling cords or rods in the hopper bottom, substantially in the manner described, and means for throwing said pinion into and out of gear with the gear wheel on the axle, substantially as described. 5th. In a seeding machine, the travelling cords or rods moving in parallel lines, and provided with the rack plates, and the sector-racks engaging and operating said rack plates, in combination with pitmen rods connecting said sector racks with and operating them from disks mounted on a shaft driven from the main axle of the machine, and means for throwing said shaft into and out of driving connection with the main axle, all substantially as described. 6th. In a seed distributor, a hopper having a groove or channel with seed openings leading thereto and therefrom, in combination with a movable cord mounted in said groove and stiffened by wire embodied therein, substantially as described. 7th. In combination, with a hopper having a feed groove and openings, substantially as described, the cord stiffened by wire and actuating devices, substantially as described, engaged by the cord at or near its middle. 8th. The hopper and the two reciprocating feeders therein, in combination with the rack plates, their actuating pinion, the guide rods and the plates holding said guides and sustaining the pinions, substantially as described.

No. 26,933. Process of Preserving Eggs.

(*Procédé de conservation des oeufs.*)

John W. McKee, Stoutland, Mo., U.S., 13th June, 1887; 5 years.

Claim.—The process, herein described, of preserving eggs, which consists in subjecting the same to the fumes of sulphurous acid and bromine, and then immersing the same in a solution of lime salt, cream of tartar, citric acid, nitrate of potash, chlorate of potash, borax, alum and water, substantially as and for the purpose described.

No. 26,934. Scrubbing Brush. (*Brosse à laver*)

Charles F. Chamberlain and George L. Lamb, Goshen, Ind., U.S., 13th June, 1887; 5 years.

Claim.—The combination, with the brush provided with the central securing screw, of the metal strip having lugs at its ends, the thumb nut on the securing screw, the handle and the wire tang seated in the lugs of the metal strip, substantially as specified.

No. 26,935. Washing Machine. (*Machine à laver.*)

James Burdock, Buckingham, Que., 13th June, 1887; 5 years.

Claim.—1st. The combination, with the ends box having grooves or slots to receive the rock shaft of the rubber, of followers E and springs F to depress the rubber, as set forth. 2nd. The handles H, H, in combination with the arms I, I, of the rubber, as set forth.

No. 26,936. Triplicate Mirror: (*Miroir Triple.*)

Peter Wiederer, Stapleton (assignee of Phillip Hufeland, New York) N.Y., U.S., 13th June, 1887; 5 years.

Claim.—1st. A triplicate mirror, having a central mirror and a wing mirror at each side of the same, said wing mirrors being mounted to move or slide toward and from the side edges of the central mirror, in a plane in line with that of the central mirror, and each of said winged mirrors being also mounted to slide toward and from the central mirror in a plane at an angle to that of the central mirror, substantially as shown and described. 2nd. A triplicate mirror, composed of a centre mirror and hinged wing mirrors, the wing mirrors being provided with strips on which said wing mirrors are mounted to slide toward and from the plane of the centre mirror, substantially as shown and described. 3rd. A triplicate mirror, composed of a centre mirror and hinged wing mirrors, the wing mirrors being mounted to slide on strips in the backing or frame of said wing mirrors, said strips being held in the backing or frame of the centre mirror, substantially as shown and described. 4th. A triplicate mirror, composed of a central mirror and two wing mirrors, the wing mirrors being mounted to slide on strips which are hinged to strips mounted to slide in the backing or frame of the centre-mirror, substantially as shown and described. 5th. In a triplicate mirror, the combination, with a central mirror and two wing mirrors, of overlapping strips mounted to slide out of the opposite edges of the central mirror, and strips mounted to slide in the backs of the wing mirrors, which strips on the wing mirrors are hinged to the opposite sliding strips of the central mirror, substantially as shown and described. 6th. In a triplicate mirror, the combination, with a central mirror frame and glass in the same, which central frame has a longitudinal slot or recess in its back, of strips mounted to slide in the recess or slot, and wing mirrors connected to the central mirror by said strips, substantially as shown and described. 7th. In a triplicate mirror, the combination, with central mirror frame and glass, of wing mirror frames, all these frames having longitudinal slots or recesses in their backs, strips mounted to slide in the recesses which strips are hinged to each other, substantially as shown and described. 8th. In a triplicate folding mirror, the combination, with a central mirror frame and two wing mirrors, of sliding strips in the back or

frames of the central and wing mirrors, and stops for preventing the withdrawing of the strips entirely from the slots or recesses in the frames, substantially as shown and described. 9th. In a triplicate mirror, the combination, with a central mirror, of sliding strips on the backing of the same, and of wing mirrors hinged and swivelled on the outer ends of the strips to swing toward and from the central mirror to be capable of adjustment at an angle to the horizontal plane, different from that of the central mirror, substantially as herein shown and described. 10th. A triplicate mirror, consisting of a central mirror, and a wing mirror hinged and swivelled to each end of the central mirror to swing toward and from the face of the central mirror, and to be adjustable at an angle to the horizontal plane different from the angle of the central mirror to the horizontal plane, substantially as shown and described. 11th. A mirror backing or frame, composed of two sheets of material, one having its edge bent over to form a hollow bead, the adjacent or inner faces of said sheets being united throughout, whereby a backing of double thickness is formed, the quadrant and the hollow bead forming a hollow rim for the frame against the inside of which hollow rim the edges of the mirror can rest, substantially as shown and described. 12th. In a mirror frame, the combination, with two sheets, of material united face to face, and a layer of corrugated material between said sheets, substantially as shown and described. 13th. In a mirror frame, the combination, with two sheets united face to face, and hinge strips between the two sheets, substantially as shown and described. 14th. In a mirror frame, the combination of two sheets, having their end edges bent over, which sheets are united face to face, the outer sheet having slots in its bent edges, and of a hinged strip extending through said slots and into the space between the two sheets, substantially as shown and described.

No. 26,937. Combination Lock.

(*Serrure à Combinaison.*)

Heber C. Griffin and Edward H. Sturtevant, Franklin Falls, N.H., U.S., 13th June, 1887; 5 years.

Claim.—1st. In a combination-lock, the fixed shaft or stud and dead tumbler mounted thereon, and toothed gear fixed to said dead-tumbler and pinion and crank for rotating it, combined with a series of disks having pins and a projection, as described, and a series of notched live-tumblers mounted upon the said shaft, and arranged alternately with relation to each other, the notches of the live-tumblers having inclined and perpendicular walls, all substantially as described. 2nd. In a combination lock, the fixed shaft or stud and dead-tumbler thereon having one or more holes *b*₁, a disk mounted loosely upon the shaft, and a fixed pin *c*₁ to enter the holes *b*₁, combined with a toothed gear fixed to said dead-tumbler, and a pinion meshing with the toothed gear and a crank to rotate the pinion, all substantially for the purpose set forth. 3rd. The fixed shaft or stud and notched dead-tumbler thereon, having one or more holes *b*₂ and fixed pin *b*₃, and a disk *c* having a fixed pin *c*₁ and a projection *c*₁, combined with the notched live-tumbler *d* mounted loosely upon the shaft, and having the fixed pin *d*₁ to follow between the projection *c*₁ and the fixed pin *b*₃, all substantially for the purpose set forth. 4th. The fixed shaft or stud and notched tumbler thereon having one or more holes *b*₂, and fixed pin *b*₃, and a disk *c* having the fixed pin *c*₂ and projection *c*, combined with the notched live-tumbler *d* mounted loosely upon the shaft having the fixed pin *d*₂, and one or more holes *d*₃ numbered in reverse order to the holes in the preceding tumbler in which the fixed pin of the succeeding disk enters, all as set forth. 5th. In a combination-lock the shaft or stud and notched dead-tumbler thereon, having one or more holes *b*₂, one or more live-tumblers mounted loosely upon the said shaft, each live-tumbler having one or more holes to correspond with the holes *b*₂, but numbered in reverse order to each other, combined with disks having a projection and fixed pins, as described, located between the said tumblers for interlocking them with each other, and yet permitting them to be moved independently of each other sufficiently that the notched portions of the tumblers may register as the dead tumbler is rotated in opposite directions, substantially as set forth.

No. 26,938. Car-Coupling. (*Attelage de Chars.*)

David Y. Wilson, Gum Tree, Robert L. McLehlan and S. Parke Rutherford, Cochransville, Penn., U.S., 13th June, 1887; 5 years.

Claim.—In an automatic car coupler, draw-heads B, B, opening C, and V-shaped springs secured therein, in combination with links *g, g* having hook-headed ends adapted to grasp a coupling-pin, and pivoted together through an elongated slot whereby the links may be opened and held together when not in use, substantially as set forth.

No. 26,939. Steam and Hot Water Radiator.

(*Calorifère à Vapeur et à Eau.*)

Samuel D. Tompkins and Thomas H. Williams, Jersey City, N.J., U.S., 14th June, 1887; 5 years.

Claim.—1st. A compound sectional radiator having, in combination a primary circulating tube, centrally located as to its next adjoining tubes, an eccentric plug and exterior air tubes joining the sections of vertical tubes at the top, constructed and operating as explained. 2nd. Lock-nut nipple I, provided with shoulder P, in combination with the section of a radiator of which it is the connecting air pipe, constructed and operating together substantially as set forth.

No. 26,940. Machine for Sprinkling Powder on Plants for the Destruction of Insects. (*Machine à Saupoudrer les Plantes pour la Destruction des Insectes.*)

Jacob F. Grobb, Beamsville, Ont., 14th June, 1887; 5 years.

Claim.—The combination of the cup or box with perforated bottom and cover handle spring loop rivets screws and bolts, substantially as and for the purpose hereinbefore set forth.

No. 26,941. Barbed Wire Fencing.*(Clôture en fil de fer Barbelé.)*

Arthur E. Goose, West Bromwich, Eng., 14th June, 1887; 5 years.

Claim.—The improved barb wire fencing, made up from short lengths of wire having sharpened or roughened ends, which are tied, threaded, or twisted into each other to form one continuous strand, substantially as herein set forth.

No. 26,942. Cultivator. (Scarificateur.)

John G. Trump, Richville, Mich., U.S., 14th June, 1887; 5 years.

Claim.—1st. In a cultivator, the arched main axle and the supporting wheels mounted thereon, in combination with the U-shaped main frame extending forward in a plane with the wheel-spindles, and having the standard *b* and the tongue adjustably secured in said standard and to the arch of the axle, substantially as herein described. 2nd. In a cultivator, the main frame, the main axle and the supporting wheels, in combination with the plates or bars *E* having rearwardly extending slotted arms *g*, the drag bars *F*, rods *h*, cross-bars *I*, levers *D* and standard *f*, substantially as herein described. 3rd. In combination with the frame *A*, plates *E* and the two series of drag-bars *F*, the centrally-placed drag-bar attachment consisting of a plate or bar *L*, having the slotted arms *l*, the drag-bars *K*, and the slotted plates *5*, the said drag-bars being secured to both plates *E* and *L*, substantially as herein described. 4th. In a cultivator, the main frame, the axle and the supporting wheels, in combination with the bar *O*, the slotted standards *P*, the levers *D* and *Q*, the rods *8*, bars *I* and the drag-bars *F*, substantially as described. 5th. In a cultivator, the means described for holding the drag bars in their adjusted positions, consisting essentially of the slotted angular standards *P*, having the heels *9* the bent levers *Q* fulcrumed in said standards and the adjustable catches in, substantially as described. 6th. In a cultivator, the combination, with the drag bars, standards and cultivator teeth, of a weed-cutter consisting of the plates *12* secured to the standards, the shank *13*, blade *14* and set screw *15*, substantially as described.

No. 26,943. Watch Case. (Boîte de Montre.)

Charles F. Morrill, Boston, Mass., U.S., 14th June, 1887; 5 years.

Claim.—1st. A watch case centre, composed of an outer shell of a precious metal, and a solid core of a cheaper metal, as set forth. 2nd. A watch case centre, composed of a core or matrix of solid silver, and a covering of gold formed on the outer surface of said core, as set forth. 3rd. A watch case centre composed of a core or matrix of solid silver, and a covering of gold formed on and soldered to the outer surface of said core, as set forth. 4th. A watch case centre composed of a solid core of silver, having no internal annular groove provided with spring receiving recesses *t* in its inner surface, as set forth.

No. 26,944. Traction Engine. (Machine Locomotive.)

Horace Longhurst, Brampton, Ont., 14th June, 1887; 5 years.

Claim.—1st. In a traction engine, a stationary iron frame *A* rigidly fastened to axle brackets *E*, *E*, in combination with iron braces *G*, *G* fastened to frame *A*, *A*, substantially as and for the purpose herein and before set forth. 2nd. In a traction engine, a stationary iron frame *A*, in combination with iron shaft *C*, and boxes or bearings *D*, *D*, supporting shaft and gearing attached thereto, substantially as and for the purpose herein and before set forth. 3rd. In a traction engine, a stationary iron frame *A*, in combination with brackets *L*, *L*, supporting shaft *F* and worm wheel *G* used for operating steering chain, substantially as and for the purpose herein and before set forth.

No. 26,945. Thumb Insertion Machine. (Machine à poser les pouces des gants.)

Anna M. Arnold, (assignee of Satterlee Arnold,) Morristown, N.J., U.S., 14th June, 1887; 5 years.

Claim.—1st. In an apparatus for folding a former, adapted to form or shape the edge of the piece to be folded, combined with means, substantially as described, for turning and for holding and clamping the folded edge. 2nd. In an apparatus for folding a former, substantially as herein described, made in two parts, arranged to be held closed together while forming the edge of the piece to be folded, and to be opened or separated for removal or withdrawal. 3rd. In an apparatus for folding the former, as herein described, having an oval opening registering with a size plate of corresponding oval, and means for turning and clamping the material, substantially as shown. 4th. In an apparatus for folding the former consisting of two handles jointed at one end, and secured to a block pivotally supported on a frame, said handles carrying the former plates which register with a size plate secured to the same frame, substantially as shown. 5th. In an apparatus for folding a former adapted to shape, crease and form the edge to be folded, combined with shovels to crowd the edges of the material so formed over the edge of the former, and means, substantially as explained, to adjust the shovels to conform to varying thicknesses of fabric. 6th. The combination, with a former or apparatus for folding the edges of goods or fabrics, of a removable clamp plate adapted to secure the folded edge in position and transfer the work, substantially as and for the purposes set forth. 7th. The combination, with a folder having a former to shape and define the edge to be folded, of a clamp plate corresponding with the shape of the folder, and arranged to clamp and transfer the prepared piece from the folder to the sewing mechanism to be finally secured, substantially as explained. 8th. The herein described method of uniting pieces of goods or fabrics, the same consisting in, first, securing or clamping the prepared goods or pieces upon a portable but rigid plate, then, transferring the plate to the sewing machine, automatically guiding and feeding the plate and the goods thereon and stitching in the desired lines or curves. 9th. An automatic feeding device

substantially as herein described arranged to receive the detachable clamp plate on which the fabric or pieces are prepared and clamped and to automatically guide and feed the same to or in connection with a sewing machine. 10th. In a machine for sewing, an automatic feeding and guiding device, arranged substantially as described, to automatically feed and guide the prepared pieces of fabric in an oval path, for the purposes set forth. 11th. In a feeding mechanism for guiding and feeding fabrics to be sewed in a curved path, means, substantially as described, for changing from one path or line of sewing to another concentric or parallel with the first, for the objects named. 12th. In a feeding mechanism for guiding and feeding fabrics to be sewed in parallel paths, means, substantially as described, for adjusting or regulating the distance between the parallel lines or paths of sewing. 13th. In a machine for sewing, a feed lever combined with an adjustable fulcrum center, and means for reciprocating said lever, substantially as explained. 14th. The clamp for clamping and securing fabrics or pieces, consisting of a plate for supporting the pieces, fingers or clamp arms supported upon said plate, and cams bearing against the clamp arms and combined therewith to clamp the goods between the fingers and plates, substantially as shown and described. 15th. In combination, with the clamp plate the clamp arms having yielding fingers for pressing the fabric against the plate, substantially as explained. 16th. The clamp plate having a chamfered edge and clamp fingers, combined with said plate and arranged to press the goods or material against the edge, substantially as and for the purposes set forth. 17th. A clamp plate having an opening in the center, and one or more clamping arms arranged around said opening, substantially as shown and described. 18th. The herein described clamp plate made in two parts, viz: a supporting frame and a second plate attached to said frame, the second plate chamfered or beveled to an edge to afford the requisite strength and desired thin edge, for the purpose of admitting the clamped fabric near to the lower surface of the plate, as set forth. 19th. In combination with the clamp plate, the clamping arms pivotally supported upon the plate, and means for pressing the arms of the fingers thereon firmly against the fabric, which means also admit of the arms being turned back out of the way for removing the fabric, as set forth. 20th. The herein described clamp plate adapted to secure and clamp fabrics while being sewed, the same having an opening or edge of the form or curve desired to be stitched, and arranged for supporting the fabric close to the line of stitching as set forth. 21st. A sliding feed lever means for guiding and feeding the lever and a clamp plate adapted to clamp and hold the fabric the parts being held guided and fed by the sliding feed lever substantially as and for the purposes set forth. 22nd. In combination with a sliding feed lever arranged to carry the fabric to be sewed, a feed mechanism for feeding the sliding lever and a guide for guiding said lever substantially as shown and described. 23rd. In combination with a sliding feed lever holding the clamped fabric to be sewed, a feeding device for feeding said lever a guide for guiding said lever and means for changing the guiding from one path or line of sewing to another substantially as shown and described. 24th. A feed shaft moved by a pawl and ratchet, a sliding feed lever operated by the feed shaft and a friction pad applied and arranged to prevent movement of the shaft except as driven by the designed action of the ratchet the parts being combined substantially as and for the purposes set forth. 25th. In a machine for sewing, a pawl ratchet plate or feed a ratchet shaft a sliding feed lever and a friction bracket, combined and arranged to operate substantially as set forth. 26th. In a machine for sewing, a pawl and ratchet, feed in which the ratchet plate is non-circular in form and in which the ratchet teeth are located on longer and shorter radii, substantially as and for the purposes set forth. 27th. In a machine for sewing, the ratchet feed plate having removable pins applied thereto and combined therewith substantially as and for the purposes set forth.

No. 26,946. Harvester Reel. (Râteau de Moissonneuse.)

William Deering, (assignee of John F. Steward), Chicago, Ill., U.S., 14th June, 1887; 5 years.

Claim.—1st. In a reel-sustaining and adjusting mechanism, the reel-sustaining post and the diagonal brace connected thereto, in combination with the standard *G* and its diagonal brace, and the reel-adjusting lever *E* jointed to the reel-bearing and to the standard, and provided with a diagonal brace, whereby the post is enabled to prevent the bagging of the reel and the lever enabled to prevent the swinging of the reel horizontally. 2nd. The horizontal rock-shaft, mounted in bearings on the frame, in combination with the reel-supporting standard, and the braces secured rigidly to the shaft and to each other, substantially as described. 3rd. The reel-sustaining post *B* and its diagonal brace, both hinged to the frame to swing backward and forward, in combination with the vertically-adjustable reel-bearing sustained by the said post, the standard *G* and its brace, both pivoted to the frame in rear of the post and its brace, the horizontal hand-lever *E* sustained by the standard and connected with the reel-shaft, and the brace *E* extending from said lever to the reel-shaft at a distance from the post *B*. 4th. In a harvester, the main standard pivoted to swing forward and backward and the reel supported thereon, in combination with the rear standard *G* also pivoted to swing backward and forward, the notched plate *I*, the locking device *H* mounted on the standard *G* and engaging the plate *I* to hold the standard in position, and a hand-lever *H* jointed to the reel-support and to the locking-slide *H*, as described, whereby the lever is adapted to lock and unlock the standard by which it is carried. 5th. In a reel adjusting mechanism, the pivoted standard *G*, its locking plate *H* and notched plate *I*, in combination with the reel-adjusting lever *E* pivoted to the plate *H*. 7th. In combination of the reel, the rock-shaft *B*, the braced reel-post *B* secured to the said rock-shaft, drum-shaft *A*, bracket *B* secured to the harvester-frame and provided with the bearings for said shaft and said rock-shaft, the gear-wheel *J* journaled on the rock-shaft, the pinion *J* mounted on the shaft *A*, and means, substantially as described, for transmitting motion from the said gear-wheel *J* to the reel, substantially as set forth. 7th. The rock-shaft *B*, the swinging reel-post connected to the rock-shaft, the gear-wheel *J* and pinion *J* rotating on said rock-shaft, the bearing plate *L* secured to the rock-shaft, and the pinion *K* journaled on said

bearing, whereby the said pinions are retained in their proper positions relative to each other and to the reel-post, all combined and arranged substantially as described.

No. 26,947. Harvester Back Board.

(*Dossier de moissonneuse.*)

William Deering, Chicago, Ill., (assignee of Robert H. Dixon, Canton, Ohio, and John F. Steward, Chicago, Ill.), U.S., 14th June, 1887; 5 years.

Claim.—1st. In combination with the harvester platform and the harvester frame, the flag having a horizontal stem or shaft joined to the harvester frame, the joint adapting the stem to fold away from the platform, substantially as set forth. 2nd. In combination with the harvester platform and the harvester frame, the flag having the horizontal stem joined to the harvester frame, the joint being adapted to allow said stem to fold upward from the platform. 3rd. In combination with the harvester platform and the harvester frame, the flag secured to the frame and adjustable back ward and forward over the platform, by means substantially as shown to suit the varying conditions of the grain, and provided with a joint adapting it to allow the horizontal stem to fold away from the platform, substantially as set forth. 4th. The flag having its stem hinged to the harvester frame, and said hinge adapted to allow the stem to fold away from the platform, provided with a stop to limit the folding of the stem toward the platform at the operative position of the flag, substantially as set forth. 5th. The flag having the stem hinged to the harvester frame, and adapted to fold upward and stubbleward, and provided with a stop to limit the folding of such hinge when the flag is overbalanced stubbleward, substantially as set forth. 7th. In combination with the platform and the seat plank, the flag having its stem secured to the seat plank, and jointed at a point grainward therefrom, and provided with the handle D 30 rigid with the stem at a point grainward from the joint, whereby the flag may be operated from the seat and be stopped by the handle coming in contact with the seat frame, substantially as set forth. 8th. In combination, with the harvester platform and the harvester frame, the flag pivoted to the harvester frame and swinging in a vertical plane upward and stubbleward over its pivot, and provided with a stop to arrest it after it is overbalanced stubbleward, and whereby it is automatically retained out of operative position, substantially as set forth.

No. 26,948. Nursery Cooking Attachment Frame for Mechanical Lamps.

(*Disposition aux lampes mécaniques pour chambres d'enfant.*)

Richard M. Wanzer, Hamilton, Ont., (assignee of John Bassemmer, New York, N.Y., U.S.), 14th June, 1887; 5 years.

Claim.—In combination with a mechanical lamp without a chimney, of a cooking frame attachment consisting of the annular ring A, annular plate C, constructed with a flange *a* and opening *b*, the ring and plate united with rods *d*, all arranged and constructed to operate, substantially as and for the purpose specified.

No. 26,949. Hydraulic Press for Coating Wires and Cables with Lead.

(*Presse hydraulique pour couvrir de plomb le fil de fer et les câbles.*)

John Robertson and James Hardie, Brooklyn, N.Y., U.S., 14th June, 1887; 5 years.

Claim.—1st. In a lead-press, the combination, with the lead-cylinder, of a coating-chamber in the walls of which are seated a diametrically opposed die and core-tube, together with a passage or passages leading from said cylinder and opening into said chamber on each side of said die and core-tube, and a bridge or partition intermediate the cylinder and the chamber and in line above the opposed ends of the die and core-tube, as specified. 2nd. In a lead-press, the combination, with the lead-cylinder, of a spherical coating-chamber in the walls of which are seated diametrically opposed to each other the die and core-tube, the bridge or partition between said cylinder and chamber extending in line above the opposed ends of said die and core-tube, together with passages leading from said cylinder to said chamber and opening one or more on each side of said die and core-tube, as and for the purpose specified. 3rd. In a lead-press, the combination, with the lead-cylinder, of a spherical coating-chamber in the walls of which and diametrically opposed are seated the die and core-tube, with the bodies thereof resting wholly in said seats, and the noses thereof only projected into said chamber, together with a bridge intermediate the said cylinder and chamber in line above the ends of said die and core-tubes and passages, one or more leading from said cylinder into said chamber and opening therein on each side of said die and core-tube, as specified. 4th. In a lead-press, the combination, with the lead-cylinder, of a distinct and separate metal block intermediate the cylinder, and the water-ram in which is formed the coating-chamber, together with a bridge intermediate said cylinder and chamber and in line with the die and core-tube seated oppositely in the chamber walls, and passages leading from said cylinder and opening into said chamber on each side of said die and core-tube, as specified. 5th. The metal block D in which is formed the chamber D and having diametrically opposite recesses on bases in which are seated respectively the die E and core-tube E', together with the bridge G and the channels *d* leading from within the circle of the shoulder *d*² to, and opening one or more into said chamber on each side of said die and core-tube, as specified. 6th. In a lead-press, the metal block D intermediate the lead-cylinder, and the water-ram and in which the chamber D is formed, the bridge G and channels *d*, as described, together with the die E and core-tube E', each constituted of the sections *e*² and *e*³ and the collar *e*⁴, as described.

No. 26,950. Metallic Pigeon-Hole Case.

(*Casier métallique.*)

The Schlicht and Field Company, (assignee of John F. Lash), Toronto, Ont., 14th June, 1887; 5 years.

Claim.—1st. The combination, with a plurality of hollow partitions, of a double angle-iron, as D, having cross-section of the form of a greek cross, and binding said partitions together, substantially as specified. 2nd. The combination of the hollow partitions A and the partitions C, provided with flanges *a* upon opposite sides thereof, and engaging the space between the walls of said partition A, substantially as described. 3rd. A series of pigeon-holes composed of the hollow partitions A, partitions B having flanges *a* to engage the space between the walls of the hollow partitions, and intermediate partitions C provided with flanges upon their opposite sides and all detachably connected together, substantially as described. 4th. A series of pigeon-holes composed of metallic partitions A and B detachably connected, in combination with the metallic back-plates E, provided with lugs *d* designed to fit into slots *c* made in the side partitions A, substantially as and for the purpose specified. 5th. A series of pigeon-holes formed of the hollow partitions A having slots *e*, partitions B having flanges *a*, intermediate partitions C, double angle-irons D, and the metallic back-plates E formed with the lugs *d* engaging in the slots *e*, substantially as and for the purpose specified. 6th. A metallic pigeon-hole case, in which all the parts composing the pigeon-holes may be readily built together or taken apart, substantially as and for the purpose specified. 7th. A combination of partitions A and B, flanges *a* joining together two or more pigeon-holes, substantially as shown in drawings.

No. 26,951. Traction or Agricultural Engine. (*Machine locomotive ou d'agriculture.*)

Henry J. F. Rose, High Bluff, Man., 14th June, 1887; 5 years.

Claim.—1st. The combination of the ratchet wheels G on the road wheels H, with the panels I in the eccentric blocks Y on the axle plates N. 2nd. The combination of the vibrating shaft D, the arms E and the rods *e*. 3rd. The combination of the steam cylinder C, with the direct connection to shaft D or to one of the axle plates N. 4th. The combination of the eccentric Y, and rods L for reversing the pawls I. 5th. The combination of the screwed rod *a* working in, the bevel wheel K, and the cross-bars *b*, *b* with the links *c*, *c*, *c*, *c*, substantially as and for the purposes hereinbefore set forth. 6th. The method of propulsion providing means whereby a fixed and stationary point is secured on which to exert the propelling force, the forward or backward continuous movement of the frame and boiler and the intermittent alternate forward (or backward) movement of the axles carrying with them the wheels which are free to revolve in the direction the machine is travelling, substantially as and for the purpose hereinbefore set forth.

No. 26,952. Horse-Shoe Nail Machine.

(*Machine à Clou à Cheval*)

George J. Capewell, Cheshire, Conn., U.S., 15th June, 1887; 5 years.

Claim.—1st. In a machine of the class described, the feed-rolls, roller-dies, the cut-off device located between them, with mechanism for operating the same, and devices for stopping the machine, combined with the slide *e*² located in or near the path of movement of the nail-blank, and means, substantially as described, connecting said slide with the devices for stopping the machine, as and for the purpose described. 2nd. In a machine of the class described, the rotary switch-plate arranged to receive the nail-blanks from the guide-way, and having a plural number of independent cross-wise channels, combined with the mechanism for turning the switch-plate with an intermittent movement, all substantially as described. 3rd. The rotary heading-plate, and devices for giving it an intermittent rotation, each step being an aliquot part of a circle, said devices consisting of a crank-arm on the heading-plate shaft bearing, a spring-pawl or ratchet-wheel, and a detent-wheel fast to said shaft, detent levers, whereby said shaft is firmly held between its rotary movements, the telescoping pitman connecting the crank arm and the driving mechanism, and the hooked arm whereby the pitman is extended, in combination with the within-described bevelling, pointing and heading-dies arranged at intervals in the path of the nail-blanks held in the die-plate, all substantially as described. 4th. The die-plate, having an intermittent rotation and bearing a plural number of dies, each having a nail-holding and head-forming socket, adapted to carry the nail-blank with its ends protruding from the plate, in combination with the bevelling dies, the trimming dies with the scrap-clearer, the reciprocating complimentary heading-die and the push-out device and its described operating mechanism, all substantially as described. 5th. In a machine for making horseshoe nails, the rotary cam *p*, fast to a shaft of the operating mechanism, the bevelling lever *p*¹, with the knuckle *p*², the spring-retracted plunger *q* bearing on its outer end one of the bevelling dies P, and the opposing base supporting the complimentary die P¹ with the annular bevel, in combination with the rotary die-plate adapted to carry the nail-blanks with the ends protruding, and in the pauses between its movements present the nail-blank to the operation of the said bevelling dies, all substantially as described. 6th. In a device for bevelling the ends of horseshoe nails, the bevelling-dies consisting of a flat-faced die having a rotary adjustment on the plunger, and a complimentary die having an annularly bevelled and counter-sunk surface, and having a rotary adjustment on the base, all substantially as described. 7th. In a machine of the within-described class, the heading-plate, having an intermittent rotation, and bearing dies adapted to present the ends of the nail-blanks to the trimming dies, the point trimming dies with the sliding scrap clearing device and the trimmer slide and its described operating mechanism, all substantially as described. 8th. In a machine of the within described class, the butt piece *d*² and a reciprocating heading-die *d*¹, combined with the die-plate *o*, having an intermittent rotation and bearing a sectional heading-die D, with all its sections backed

up against lateral movement by the substance of the plate, and also having a die-socket opening through the die to the front and rear of the plate, all substantially as described. 9th. In combination with the die-plate *o*, having an intermittent rotation, and bearing a plural number of sectional heading-dies *D*, the sliding wedge with bevelled and projecting end, the complimentary heading die *d*¹⁰, the spring-seated plunger *d*¹¹, the butt-piece and the wedge-operating cam *d*¹⁴, all substantially as described. 10th. In a machine of the within-described class, the wire straightening lever bearing, the guide-rolls, the feed-rolls borne in the machine, and the swinging lever of the stop device held in contact with the wire of stock as it is fed into the machine and adapted to swing across its path and stop the machine when the end of the wire is reached, all substantially as described. 11th. In combination with the feed-rolls of the within-described machine, the spring-seated bearing-blocks, and the roll-separating device, consisting of a wedge with its points located between the rolls, and connected to a lever pivoted to the frame of the machine, all substantially as described. 12th. In combination with the feed-rolls of the within-described machine, the rod-straightening lever bearing the guide-rolls on opposite sides of the path of the rod as it is fed into the machine, and the removable clamp device, whereby the said lever is clamped in position for use, all substantially as described. 13th. In combination with the feed rolls of the nail machine, the adjustable gauge *l* located in the path of the nail-rod, the cutters for severing a nail-blank from the rod, the cut-off lever, the wiper that operates the cut-off lever, the cut-off lever latch and the stop device, all substantially as described. 14th. In combination with the cut-off device, having a reciprocating live cutter, the slide-block *2* in the path of the cutter, the connecting-rod *3*, the stop-finger *4* and the rotary rod *L* of the stop mechanism, all substantially as described. 15th. The combination of the guideway leading from pair to pair of roller dies and formed between blocks, the outer one of which is removable, the spring-repressed stop-lever *K*, having one end in contact with the removable block *K*₂, and the other in contact with the stop-finger fast to the rotary stop-rod *L* and the stop-finger, all substantially as described. 16th. In combination with the removable block *K*₂, on the inner side of which a portion of the nail-guideway is formed, the stop-lever, composed of the lever part *k* overlapping the lever part *k*₃, and bearing a turn-button with its edge adapted to engage the outer edge of the lever part *k*₃, the spring *k*₅ and the stop finger fast to the stop-rod *L*, all substantially as described. 17th. In combination with the removable cutter-block *K*₂ of the guideway, the spring-repressed lever *k* and the indicator *J*, automatically displayed by the movement of the lever *k*, when the nail-blanks become clogged in the guide-way, all substantially as described.

No. 26,953. Snow Shovel. (*Pelle à neige.*)

Johb R. McLaren, Jr., Montreal, Que., 15th June, 1887; 5 years.

Claim.—1st. The combination, in a snow shovel, of the blade and the handle bent at its junction therewith, and terminating in a forked end, on which the blade is secured, all as herein set forth. 2nd. The combination of the bent handle *B*, with forked end *b, b*, blade *A* secured thereon, and rib *D* secured to blade and handle, all substantially as described.

No. 26,954. Tobacco Pipe. (*Pipe à fumer.*)

John G. Bruneau, Quebec, Que., 15th June, 1887; 5 years.

Claim.—1st. The combination, with the stem sections *B, C*, of the ferrule *D* having a lateral opening provided with a tube or funnel-shaped orifice *H*, and the bulb *F* removably attached to the ferrule and enclosing the tube, for the purpose set forth. 2nd. The combination of the stem sections *B, C*, provided with projecting tubes *B₁, C₁*, ferrule *D* having a lateral opening provided with a tube or funnel-shaped orifice *H*, and a bulb *F* attached to the ferrule to enclose the tube, as set forth. 2rd. In a tobacco pipe, the combination of the ferrule *D* having a lateral opening provided with a tube or contracted orifice *H*, a bulb *F* attached to the ferrule, and stem sections *B, C* closing the ends of the ferrule, as set forth, whereby nicotine and saliva collected in the bulb cannot return to the stem.

No. 26,955. Faucet. (*Robinet.*)

Seth Beach, Cedar Rapids, Iowa, U.S., 15th June, 1887; 5 years.

Claim.—1st. The shank *B* formed on one end of the faucet, and the lugs *C* projecting outward from the end of the said shank in combination with the jam-nut *E*, screwing on the threaded part *D* of the faucet *A*, substantially as shown and described. 2nd. The tin can *F* having an aperture *G* and the plate *H* covering the said aperture from the inside of the can, in combination with the faucet *A*, provided with the shank *B* having the lugs *C* and the screw-threaded part *D*, substantially as shown and described.

No. 26,956. Cuff Fastener. (*Fermeoir de Poignets.*)

Thomas E. Barrow, Mansfield, Ohio, U. S., 15th June, 1887; 5 years.

Claim.—1st. The combination, with the contiguous spring bars, one or both of which is recessed, as described, of means carried by said bars for securing them to the cuff button, substantially as and for the purpose hereinbefore set forth. 2nd. The combination, with the contiguous spring bars forming recesses for holding, and being adjusted upon the wrist band stud, of a loop for engaging the cuff button, substantially as and for the purpose hereinbefore set forth. 3rd. The combination, with the contiguous spring bars having a series of communicating recesses for engagement with and adjustment upon the wrist-band stud, of a relatively small loop adapted to encircle the shank of the cuff button, and a relatively large loop adapted to be passed over the head of the cuff button shank and over the wrist-band stud, substantially as and for the purpose hereinbefore set forth.

No. 26,957. Wire Drawing Machine. (*Filière à Tirer.*)

Martin F. Roberts, Kilburn, Eng., 15th June, 1887; 5 years.

Claim.—1st. The combination, with the driving shaft, a counter-

shaft driven therefrom, a friction disc mounted on a feather key on said countershaft, and means for adjusting the position of said disc on the shaft, of a second friction disc driven at varying speeds as required by the first-named friction disc, and secured on a shaft upon which a drawing through pulley is also secured, substantially as herein set forth for the purpose specified. 2nd. The combination, with the driving shaft, a countershaft driven therefrom, a friction disc mounted on a feather key on said countershaft, and means for adjusting the position of said disc on the shaft, of a second friction disc driven by the first named friction disc and secured on a shaft geared to a shaft on which is secured a wire drawer's block, substantially as herein set forth for the purposes specified. 3rd. The combination, with a series of countershafts driven at varying speeds as required, from a driving shaft of adjustable frictional gearing for driving at varying speeds a series of shafts, one of which is geared to the shaft which carries the wire drawer's block, and the remaining shafts carry drawing through pulleys, substantially as herein set forth for the purposes specified. 4th. The combination, in a wire drawing machine, with a series of pulleys *C* driven at increasing surface speeds, of friction discs *g* and *h* respectively for altering and adjusting the speed of said pulleys, as required, substantially as herein set forth for the purposes specified. 5th. The combination, in a wire drawing machine, with a block *d*, of friction discs *g* and *h* for altering and adjusting the speed of said block, as required, substantially as herein set forth for the purposes specified. 6th. The combination, with a series of countershafts driven at varying speeds from a driving shaft, and transmitting motion by adjustable frictional gearing to a series of shafts on which are secured the drawing through pulleys, of a trough or lubricant reservoir revolving discs, a channel for collecting and guiding the lubricant onto the wire passing through an open channel secured to the die holder, substantially as herein set forth for the purposes specified. 7th. The combination, with a series of countershafts driven at varying speeds from a driving shaft, and transmitting motion by adjustable frictional gearing to a series of shafts on which are secured the drawing through pulleys, and hinged brackets supporting beneath the lubricant adjustable die holders, of a lubricant trough, provided with a well and a piston or plunger for emptying and filling said trough, constructed and arranged substantially as herein set forth for the purposes specified. 8th. The combination, with a drawing through pulley of a die supported in a self-adjusting die-holder, constructed and arranged substantially as herein set forth for the purposes specified. 9th. The combination, with a trough or reservoir containing lubricant, and a revolving disc for raising said lubricant, of means, such as the channel *m* for collecting and guiding said lubricant on to a channel forming part of the die holder, and through which channel the wire passes, substantially as herein set forth for the purposes specified. 10th. The combination, with a bracket secured adjustably to the frame, of a die-holder suspended by a gimbal device, substantially as herein set forth for the purposes specified. 11th. The combination, with a bracket secured adjustably to the frame, of a die-holder suspended by a ball and socket or universal joint, substantially as herein set forth for the purposes specified. 12th. The combination, with a bracket secured adjustably to the frame of a die-holder formed of spiral springs, and arranged substantially as herein set forth for the purposes specified.

No. 26,958. Time Piece. (*Chronomètre.*)

Joseph Pallweber, Salzburg, Austria, 15th June, 1887; 5 years.

Claim.—1st. In a time-piece, the combination of two minute-dials mounted one above the other on the same arbor, and arranged to rotate independently of each other, one of said dials bearing the unit numerals and the other the tens, the latter dial having slots through which the units are exposed to view with a main train, an escapement comprising the pinions *W* and *W₁* and the spring-actuated pawl-lever *L* controlled from pinion *W*, and controlling the pinion *W₁*, a transmitting-gear to transmit the movements of the pinion *W₁* to the units minute-dial, and transmitting-gear controlled by the escapement for rotating the tens minute-dial, each complete revolution of the ratchet *W₁*, substantially as described for the purpose specified. 2nd. In a time-piece, the combination of two minute-dials mounted one above the other on the same arbor, and arranged to rotate independently of each other, one of said dials bearing the unit numerals, and the other the tens, the latter dial having slots through which the units are exposed to view with a main train, an escapement comprising the pinions *W* and *W₁*, and the spring-actuated pawl-lever *L* controlled from pinion *W*, and controlling the pinion *W₁*, a transmitting-gear to transmit the movements of the pinion *W₁* to the units minute-dial, and transmitting-gear consisting of the wheel *C₁* on the arbor of the pinion *W₁*, and the pinion *C* on the arbor of the minute-dials, substantially as described for the purpose specified. 3rd. In a time-piece, the combination of two superposed hour-dials, one of which bears the hour-unit numerals, and the other two tens numerals and the numerals 22, 23, 24, the latter dial being slotted to expose the numerals on the unit-dial, with a main train and an hour train operating the hour-dials to indicate the hours from 1 to 24 successively, substantially as described. 4th. In a time-piece, the combination of two hour-dials mounted on the same arbor, one of which dials bears the hour-unit numerals, and the other the numerals 12 of the tens, and the numerals 22, 23 and 24, the latter dial being slotted to expose the numerals on the unit-dials with a main-train and an hour-train operating the hour dials to indicate the hours from 1 to 24 successively, substantially as described. 5th. In a time-piece, the combination of two hour-dials mounted on the same arbor and arranged to rotate independently of each other, one of said dials bearing the hour units and the other the numerals 12 of the tens, and the numerals 22, 23 and 24, the latter dial being slotted to expose the units on the unit-dials, with a main-train and an hour-train operating the hour-dials to indicate the hours from 1 to 24 successively, substantially as described. 6th. In a time-piece, the combination of two superposed minute-dials each bearing numerals, one of said dials being slotted to expose the numerals on the other, and two superposed hour-dials each bearing numerals one of said dials being also slotted to expose the numerals on the other with a main-train, a minute-train controlled thereby to operate the minute-dials, and an hour-train controlled by the

minute-train to operate the hour-dials, substantially as described. 7th. In a time-piece, the combination of two superposed hour-dials, one bearing a portion of the hour-unit numerals, and the other bearing the tens numerals, and the remaining portion of the series, the latter dial being slotted to expose the numerals on the dial below with a main-train and an hour-train operating the hour-dials to indicate the full series of hours successively, substantially as described. 8th. The combination of the arbor a_5 , the ratchet-wheel W_2 and the mutilated gear I_2 on said arbor, and a pawl for imparting to the ratchet a step-by-step rotation of the arbor A , the hour-dial H loosely mounted thereon, the pinion i_2 and brake-disk i_1 rigidly connected with the hour-dial H , substantially as described for the purpose specified. 9th. The combination of the arbor a_5 , the ratchet-wheel W_2 , the mutilated gear-wheel i_2 and brake-disk i_1 on said arbor, and a pawl for imparting to the ratchet a step-by-step rotation of the arbor A , hour-dial H brake-disk i_5 , and pinion i_1 , substantially as described for the purpose specified. 10th. The combination with a main-train, the arbor a_2 , its pinion W , and the spring-actuated pawl-lever L having push-pawl l_2 of the arbor a_2 , the wheels W_1 and C thereon, the arbor A , the minute-dial H , loose on arbor A , and the gear-wheel M rigidly connected with the hour-dial H , substantially as and for the purpose specified. 11th. The combination with a main-train, the arbor a_2 , its pinion W , and the spring-actuated pawl-lever L having push-pawl l_2 , of the arbor a_2 , the wheels W_1 and C thereon, the arbor A , its pinion C and the hour-dial H rigidly connected with said arbor A , substantially as and for the purpose specified. 12th. In a time-piece, the combination with two minute-dials on one arbor, and two hour-dials on another arbor, a main-train, a minute-train for operating the minute-dials, a pawl-lever controlled by the main-train and operating the minute-train, an hour-train for operating the hour-dials, and a pawl-lever for operating the hour-train, of setting devices comprising a lever for throwing either of the operating-pawls on the minute and hour-trains out of operation, and gearing for operating said trains independently of each other and of the main-train, substantially as described.

No. 26,959. Hot Water Sectional Boiler.

(*Calorifere à eau.*)

Charles Plaxton, Winnipeg, Man., and John Plaxton, Barrie, Ont., 15th June, 1887; 5 years.

Claim.—1st. A hot water boiler composed of a series of hollow sections A , having horizontally-projecting hollow fingers B formed on each section, which sections are arranged in pairs opposite to each other, so that the fingers of one section shall project between the fingers of the section opposite to it, forming a zig-zag flue C , substantially as and for the purpose specified. 2nd. The combination with a furnace, of a hollow section A , having horizontally-projecting hollow fingers B , with a dividing partition J placed in each finger, an inlet pipe F , and an outlet pipe G , for the purpose of admitting water to circulate through the said hollow sections and fingers, substantially as described. 3rd. A hot water boiler composed of a series of hollow sections A , having horizontally-projecting hollow fingers B , formed on each section, which sections are arranged in pairs opposite to each other, so that the fingers of one section shall project between the fingers of the section opposite to it, forming a zig-zag flue, C , in combination with a slanting partition M , arranged substantially as and for the purpose specified.

No. 26,960. Harrow. (*Herse.*)

Gustavus A. Paddock, Beaver Dam, Wis., U. S., 16th June, 1887; 5 years.

Claim.—1st. The combination of tooth bars D_1 and D_2 , with a tooth-bar C_2 between them, and oscillatory draw-bar H , substantially as described. 2nd. The combination of tooth-bars C and C_1 rigidly connected, and a tooth-bar D working independently between them, substantially as and for the purposes hereinbefore set forth. 3rd. The combination of tooth-bars D and D_1 secured by a cross-piece F , and a tooth-bar C working under said cross-piece, substantially as and for the purposes described. 4th. The combination of frame A , with frame B , each of said frames carrying teeth, and the bars of the two frames alternating, substantially as described. 5th. The combination of a frame A , with a separate overlapping frame B and an oscillating draw-bar H , substantially as and for the purposes hereinbefore set forth. 6th. In a harrow, an oscillating draw-bar H , substantially as and for the purposes hereinbefore set forth.

No. 26,961. Propelling Gear for Vehicles.

(*Appareil de propulsion des voitures.*)

William H. Burkholder, Bracebridge, Ont., 16th June, 1887; 5 years.

Claim.—1st. The jointed bar A journalled at one end on the crank B and pivoted at its other end to the frame C , the vertical rod D connected at its lower end to the joint of the bar A , and at its other end to the bar E which is attached to the shaft F , in combination with the segment gear G , attached to the shaft F and meshing with the segment gear H attached to the shaft I which has attached to it the stirrups J , or their equivalent, substantially as and for the purpose specified.

No. 26,962. Shoe. (*Soulier.*)

William F. Maurer, Harmony, Ind., U. S., 16th June, 1877; 5 years.

Claim.—The combination of the soles of a shoe, a vamp made in one piece of sole-leather secured between said soles and having its ends joined in a seam at one side of the shoe, and an upper made in one piece having a slit in the instep, and having its ends joined in a seam at the opposite side of the shoe to that upon which is the seam in the vamp, the said upper being secured by its lower edge to the upper edge of the vamp.

No. 26,963. Washing Machine.

(*Machine à laver.*)

Robert Hazlitt, Belleville, Ont., 16th June, 1887; 5 years.

Claim.—1st. In a pneumatic washing machine, the spherical diaphragm D provided with conical deflector E and holes H , as and for the purpose hereinbefore stated. 2nd. Tubular handle A , provided with shield B and conical body C having holes G , as and for the purpose hereinbefore set forth. 3rd. The combination, in a pneumatic washer, of diaphragm D , conical deflector E , and water deflector F , as and for the purpose hereinbefore set forth.

No. 26,964. Steam and Electric Connection for Railway Cars. (*Conduit de vapeur et d'électricité pour chars de chemin de fer.*)

Benjamin R. Deacon, Montreal, Que., 16th June, 1887; 5 years.

Claim.—1st. In combination with the heater-pipes of a railway car: the flexible pipes d_2 , stop-cock b_2 , "cylinder-pipe" and "piston-pipe" having arms, as described, for holding the spring-actuated heads f_1 and r_1 in place, in relation to the said "cylinder-pipe" and "piston-pipe" with said spring-actuated heads, the said head r being provided with attachments, as described and shown, for operating the stop-cock b_2 , standard m_1 having head n , slide d having arms m, n , also having washer h and actuating spring i , socket formed (or provided brackets a and spring i_2 , the one railway car so provided and the parts thereof operating and combined with similar parts provided on the car coupled with it, the whole substantially as described for the purposes set forth. 2nd. In combination with the heater-pipes of a railway car, the flexible-pipes d_2 , stop-cocks b_2 , "cylinder-pipe" and "piston-pipe", as described, socket-formed brackets a and springs i_2 , the one railway car provided with these said parts, in combination with another car similarly provided, the whole substantially as described for the purposes set forth. 3rd. The combination of the socket-formed brackets a , pipes d having ball c and stopper a , casing and shell c_4, b_4 provided with cylinder f having bell-mouth g , and provided with pipe e having packing i , and spring-actuated sleeve d_1 , the said pipes d being also provided with arms, as described and shown, for holding spring-actuated heads f_1 provided with insulated electrical circuit wires g_1 with said spring-actuated heads f_1 and said wires g_1 , and with the spring-actuated heads r_1 and r_1 provided with sleeves v_6 and v_7 , links u_1 and stop-cocks b_2 attached to each end of the system of heater-pipes of the car, said car being provided as stated with the parts at both ends of it, in combination with another railway car similarly provided with parts, the whole substantially as described and shown for the purposes set forth. 4th. The combination of a car having a system of heater-pipes extending from one end of it to the other end, and having at each end of the car connected with each end of the said system of heater-pipes, the flexible pipe d_2 , stop-cock b_2 , pipe d , casing c_4 having cylinder f and pipe e having packing i , the pipe d having also ball c , socket-formed bracket a and spring v_2 with another car, similarly provided with the above-mentioned parts at each end, the whole substantially as described for the purposes set forth. 5th. The standards u attached upon an automatically adjusting device, as described, sleeves v , springs b_1 , insulators e_1 , heads i and wires g_1 arranged at the end of a car, as described, in combination with similar parts on the end of another car arranged to agree therewith, the whole substantially as described.

No. 26,965. Metal Shingle. (*Bardeau métallique.*)

Nelson Green, Waterford, Ont., 16th June, 1887; 5 years.

Claim.—A rectangular metal sheet having formed on two of its adjacent edges a single narrow fold on one side of the plate, and having on the remaining two adjacent edges and on the opposite side of the sheet a double or S-shaped fold, formed substantially as and for the purpose specified.

No. 26,966. Window Fastener. (*Arrête-croisée.*)

Reuben Clarke and William F. Munro, Toronto, Ont., 16th June, 1887; 5 years.

Claim.—1st. The combination of the box H having a slot formed therein, the spindle I , the notched quadrant K , the bar L carrying a catch and a pin which enters a slot formed in said quadrant, and having a guide for the enlarged head of the pin O which is actuated by the movement of said quadrant, and the spring N which has bearings on said pin and the slotted end of the bearing piece p , substantially as specified. 2nd. The combination of the box H , the spindle I carrying a thumb-piece, the notched quadrant K , the bar L and the bar M pivotally connected with the said quadrant and adapted to move the catches a and b in opposite directions when actuated by said quadrant in slots formed in said box H , and provided with guides for the head of the pin O which is so formed as to enter the notches in said quadrant as it is caused to rotate, and the spring N having suitable bearings, and adapted to keep the head of the pin pressed into the notches on the quadrant, substantially as described and for the purpose specified. 3rd. In combination with a window frame and sash, a box let into the side of the window frame, and provided with mechanism adapted to move in a slot formed in said box, a catch which is fitted to engage in suitable bearings, provided by a stop-groove formed in the window-sash, substantially as described and specified. 4th. In combination with a window-sash, a stop-groove F rigidly attached to said sash in a recess made therein, as to admit of a catch b engaging therein when actuated by mechanism let into the side of the window-frame and locking the sash, substantially as specified. 5th. In combination with a window-sash, a stop-groove F rigidly attached to said sash in a recess made therein, and having a slot 3 and groove 7 so formed as to admit of a catch b passing into said groove, and engaging at the end thereof when said catch b is actuated by mechanism let into the side of the window-frame, and locking said sash after it has been partially opened, substantially as specified. 6th. In combination with a window-frame and sashes,

the box H with mechanism adapted to operate the catches *a* and *b*, and the stop-grooves E and F which afford suitable bearings for the catches *a* and *b* so as to lock in position the sashes B and C, substantially as described and specified. 7th. The box H let into a window-frame, the spindle I, notched quadrant K, the bar L and the bar M pivotally connected with said quadrant and adapted to move the catches *a* and *b* in opposite directions when actuated by said quadrant, and provided with guides for the head of the pin O which is so formed as to enter the notches in said quadrant as it is raised to rotate, and is held therein by the action of the spring N, in combination with the stop-groove E let into the upper sash, and the stop-groove F let into the lower sash, and having slots 2 and 3 and grooves 7 and 8 which afford suitable bearings on which the stops *a* and *b* may engage when moved into position by the thumb-piece A formed on the end of said spindle I so as to lock the sashes B and C in the required position, substantially as specified. 8th. An adjustable window-fastener formed on the window-frame, and having catches adapted to engage in suitable bearings, formed on the sashes in such a manner that when the window-fastener is set to permit of the sashes being partially opened it is necessary to close the same from the inside before resetting the fastener, when it is desired to throw the sashes up to their full extent and permit them to move free from the catches, substantially as described and specified.

No. 26,967. Pump. (*Pompe*.)

Robert C. Hickok, (assignee of George S. Putnam), Buffalo, N. Y., U.S., 16th June, 1887; 6 years.

Claim.—1st. In a pump, the combination, with a single cylinder A and heads B, B', of the hollow plungers C, C', the plunger proper D attached thereto and consisting of the parts 1, 2, 3 fastened together, having water-ways *m* leading from the lower part of cylinder A into the hollow plunger C above, and openings *n* leading from the hollow plunger C' below into cylinder A above plunger D, the interposed leather packing rings and valves I, I' constructed in connection therewith, and the upper and lower disks E, F having interposed leather packing rings *e* and valves *b, b'*, water opening *a, a'* and glands *g, g'*, *i, i'* in seats *h, h'* in the lower part or disk E, all constructed, arranged and operating substantially as set forth. 2nd. In a single cylinder double-acting pump, the combination, with the plunger C, C', of the disks E, F situated above and below the plunger proper D, as described, and having the loose glands *g, g'* with lugs *i, i'* setting in sockets *h, h'* with interposed rubber packing *k, k'*, and the centering and clearance spaces *c, d* between the glands and lower disk F, all substantially as and for the purpose specified.

No. 26,968. Harvester. (*Moissonneuse*.)

William Deering, (assignee of John F. Steward), Chicago, Ill., U. S., 16th June, 1887; 15 years.

Claim.—1st. In combination with the front and rear sill, and the trusses D and E connecting them on the grain side of the wheel, the segment G secured to the truss D, the rod J strutting the truss E, the cross-bar H and the brace I, united and operating substantially as and for the purpose set forth. 2nd. In combination with the front and rear sills, and the truss connecting them on the grain side of the wheel, the inner segment secured to said truss, and a brace connected to its upper end and extending grainward to a fixed part of the harvester frame, and the drive wheel axle, and the raising and lowering pinions made fast thereon and engaging the segment backs and shrouded on both sides thereof, substantially as set forth. 3rd. In a harvester, a gearing frame composed of two separate parts having the bearings for the primal shaft wholly in one part, and the bearings for the secondary shaft wholly in the other part, and having formed integral with each part a portion of a gearing case, said portions matches to form a continuous cover when the two parts of the frame are joined, substantially as set forth. 4th. A gearing frame and cover having bearings for two shafts at right angles divided, and having the bearing for one of the shafts wholly in one part, and the bearings for the other shaft wholly in the other part, and having its said parts secured together at a plane parallel to one of the shafts, and located between said shaft and the nearest bearing of the other shaft, substantially as set forth. 5th. In a harvesting machine, a gearing frame and cover composed wholly of two separable parts, the bearings for the shaft being wholly in one part, and the bearings for the secondary shaft being wholly in the other part, and means, substantially as described, for adjustably securing said parts together. 6th. In combination, substantially as set forth, the partial gearing frame M having bearings for one shaft, the truss bars and the rear sill B of the harvester frame, and the adjusting screw M₄ set through a flange on the partial frame M against the rear sill for the purpose of adjusting said parts of the frame.

No. 26,969. Bundle Carrier for Grain Harvesters. (*Porte-gerbe pour moissonneuses*.)

William Deering, (assignee of John F. Steward and Burr A. Kennedy), Chicago, Ill., U.S., 16th June, 1887; 15 years.

Claim.—1st. In combination with the harvester frame, the bundle carrier frame comprising four bars, as B, B, B', B', extended rigidly outward from the stubble end of the harvester frame, and the channel iron secured to the outer ends of the said bars and having its lips horizontal, and the intermediate web vertical and the carrier arms journalled in the said horizontal lips, as shown and described. 2nd. In combination with the harvester frame, the bundle carrier frame comprising four bars B, B, B', B' extending rigidly outward from the stubble end of the harvester frame and a bar, as C, secured to the outer end of the bars B, B, B', B' having the lips horizontal and the intermediate web vertical, and the carrier arms journalled on said horizontal lips, and a brace bar, as G, and screwed at its forward end to one of the forward bars B near its outer end, and at the rear end to the rear outer portion of the harvester frame, substantially as set forth. 3rd. In combination with a trussed frame forming the stubble end of the harvester frame, the bundle carrier comprising

four bars B, B, B', B' extended rigidly outward from trussed frame, and a bar, as C, secured to their outer ends, and braces C₂ secured to the trussed frame near the widest part and to the outer ends of the lower bars B, substantially as set forth. 4th. In combination with the bundle carriers arms, formed and adapted to operate substantially as described, the channel iron bar C fixed with its web vertical and its flange horizontal, and having in the upper flange the aperture *c*, and in its lower flange the elongated apertures *c'*, constituting respectively the upper and lower bearings for the carrier arms, as described. 6th. In combination with the carrier arms, having the vertical axial portions D₂, and the horizontal portions D₃, the angular clips I₁ having the apertured wing H₁ and provided with the flexible lugs *k*₂, substantially as set forth.

No. 26,970. Saw Mill Set Work.

(*Déclie de chariot de scierie*.)

Tatum & Bowen, (assignees of Alpheus E. Roe), San Francisco, Cal., U.S., 16th June, 1887; 5 years.

Claim.—1st. In a saw-mill set-works, the ratchet-wheel secured to the head-block screw, the arms B, B' mounted on said screw and extending in opposite directions, the pawls C, C' journalled in said arms upon opposite sides of the ratchet-wheel, and alternately operating said wheel, in combination with the vertical guide-rods, the yoke E moving in said guide-rods, the links D, D' connecting the yoke with the arms B, B', a stop at the other end of the guide-rods having arms of unequal length, as described, and the adjustable block O at the lower end of the guide, substantially as herein described. 2nd. The ratchet-wheel on the head-block screw, the arms B on said screw having the alternately-operating pawls C, C', and a yoke connected with said arms, in combination with an adjustable stop composed of the arms projecting radially unequal distances from a central shaft about which they may be turned, so as to act as a stop for the upward movement of the yoke E, substantially as herein described. 3rd. In combination with the pawls fulcrumed to the lever arms moving about a common centre, with the ratchet-wheel links connecting the arms with a yoke which moves in a vertical guide, as shown, the movable block or step at the lower end of the guide, the cam or eccentric connected with said stop by which it is raised or depressed, and an actuating-lever and segment-rack, substantially as herein described. 4th. The ratchet-wheel secured to the head-block, screw-arms moving about the same common centre, carrying pawls which engage the teeth of the ratchet-wheel, as shown, when the arms are raised or depressed, in combination with the curved lifters H, H' and the slotter lever J, whereby the lifters may be caused to move the pawls and disengage them from the teeth of the ratchet-wheel, substantially as herein described.

No. 26,971. Window Fastener. (*Arrête-croisée*.)

William R. Abrams, Ellensburg, W. T., U. S., 17th June, 1887; 5 years.

Claim.—1st. The combination of the plate A, made wedge-shaped at one end, and having the slotted end piece *a* hinged to the opposite end, the plate *b* bent twice at right angles provided with points *c* and secured to the plate A, and the bar B provided with the screw-threaded stud *e* and wing-nut *f*, and bent at right angles at one end, substantially as described. 2nd. A fastener for upper and lower sashes, comprising a plate having one end wedge-shaped to enter between the lower sash and the frame, a plate hinged to the opposite end of the said plate and penetrating points intermediate of said ends, and a transverse plate clamped to the hinged plate at right angles thereto, and having its inner end bent at right angles to enter between the side rail of the upper sash and the parting strip of the window-frame, substantially as set forth.

No. 26,972. Driving Wheel of Locomotive.

(*Roue conductrice de locomotive*.)

Charles E. Swinerton, New York, N. Y., U. S., 17th June, 1887; 5 years.

Claim.—The driving-wheels of locomotives, having a polygonal form with plane surfaces or faucets upon their peripheries or treads between the angles of the polygonal, substantially as and for the purpose herein specified.

No. 26,973. Sulky Plough. (*Charrue à siège*.)

Horatio Gale, Albion, Mich., U.S., 17th June, 1887; 5 years.

Claim.—1st. The combination, with a sulky plough frame, of a plough beam pivotally secured thereto at one end, and at the opposite end carrying a guide yoke embracing said frame and beam, substantially as and for the purposes specified. 2nd. The combination, in a sulky plough, of a castor wheel provided with a notched segment, with a spring latch adapted to be automatically retracted by the action of the lateral swing of the tongue, substantially as described. 3rd. The combination, with the frame of a sulky plough, of vertically journalled standard carrying upon one end an adjustable pole, the opposite end being secured to a stub axle carrying a traction wheel, substantially as set forth. 4th. In a sulky plough, the combination of a frame A, traction wheels B, I, stub axles C, H, bracket F, vertical standard G, draft iron J, and pole K, the parts being combined and arranged substantially in the manner and for the purposes specified. 5th. The combination of the frame A, plough beam S and yoke V, substantially as and for the purposes described. 6th. In a sulky plough, the combination, of the frame A carrying traction wheels B and I, castor wheel N, notched segment O and spring latch P, substantially as and for the purposes set forth. 7th. The combination, in a sulky plough, of the frame A supported upon traction wheels B and I, with the plough beam S attached as described to the frame plough U attached to said beam link Z, latch lever W, segmental rack T, and yoke V, substantially as and for the purposes described.

No. 26,974. Balanced Rotary Slide Valve and Gear for Steam Engines.
(*Tiroir de vapeur équilibré et distribution par tiroir pour machines à vapeur.*)

James T. Milne, Peterborough, Ont., 17th June, 1887; 5 years.

Claim.—1st. A circular conical slide valve having an admission port *c* opposite recess *c*₁ of equal area, connecting passage *c*₁ and exhaust passage *c*₂, substantially as set forth. 2nd. The combination, with a circular conical valve *C* of the port *c*, balance recess *c*₁ connecting passage *c*, exhaust passage *c*₂. 3rd. The combination, of the cylinder *A*, port *a*, steam passage *a*₁, conical cylindrical valve *B*, steam ports *b*, exhaust ports *b*₁, exhaust passages *a*₂, and valve *C*, substantially as set forth. 4th. The combination, with the valve *C*, of the admission port *c*, passage *c*₁, recess *c*₁, exhaust passage *c*₂ and ports *a*, *b*, *b*₁, substantially as set forth. 5th. In combination with an oscillating cylinder, the circular conical valve *C*, disks *D*, connecting link *E*, substantially as set forth. 6th. In combination, with an oscillating cylinder *A*, and valve box *B*, the valve *C*, disks *D*, connecting link *E*, disk *G*, slide *g* and link *F*, substantially as described. 7th. In combination with an oscillating cylinder *A* and valve box *B*, the valve *C*, disks *D*, link *E*, disk *t*, slide *g*, link *F*, slot *f*, and handle *F*₁, substantially as set forth. 8th. In combination with a double cylinder oscillating engine, having cylinders *A* and valve boxes *B*, the valve *C*, disks *D*, links *E*, disks *G*, slides *g*, links *F*, slots *f*, pivot *f*₁, lugs *f*₂, links *F*₁, and lever *F*₁, substantially as set forth.

No. 26,975. Garden Rake.

(*Râteau de jardinier.*)

Joseph W. Calef, North Easton, Mass., U. S., 17th June, 1887; 5 years.

Claim.—A garden rake having the common teeth *B*, *B*, and two or more flattened teeth *C*, *c*, *c*, as above described and for the purposes set forth.

No. 26,976. End Gate for Waggon.

(*Equignon de tombereau.*)

Morris S. Tyler, Lansing, Mich., U. S., 17th June, 1887; 5 years.

Claim.—1st. An end gate provided with an independently movable section, said section being the lower portion of the end-gate with exception of a small standing portion at one end integral with said gate, section of a small standing portion at one end integral therewith, of the end-gate *C*, and vertical portion *E* formed integral therewith, of the independently movable section *E*, cleat *H* on said vertical portion forming a rabbet *G* and a fastening *J* for securing the section *E* to said portion *F*, substantially as and for the purpose specified.

No. 26,977. Store Service Apparatus.

(*Appareil de service de magasin.*)

Benjamin C. Algie, Ogdensburg, N. Y., U. S., 17th June, 1887; 5 years.

Claim.—1st. The herein-described method of propelling cars of a store service apparatus, which consists in arranging, beneath and substantially parallel with the track wire, a propelling cord extending beneath the same, adapted to propel the car on the track wire by forcibly increasing the distance between the track wire and propelling cord, so as to form a progressive wedge in the immediate rear of the car as it relates to the direction in which said car is to be sent. 2nd. In a store service apparatus, the combination of the track wire, the car having the grooved upper and lower wheels and the propelling cord, arranged substantially as described. 3rd. In a store service apparatus, the combination, with the track wire and the car having the grooved rollers, of the propelling cord arranged substantially parallel to, and beneath the track wire, and detachably secured by forked studs at each of its ends, substantially as described. 4th. In a store service apparatus, the combination, with the track wire, of a hinged bracket provided with a stopping lever, the outer end of said lever being pivotally secured to the outer end of said bracket, and the inner end provided with an upward curve or arch, and a wheel upon said wire adapted to engage with a groove on the lower edge of said lever. 5th. In a store service apparatus, the combination, with the bracket, the track wire, the propelling cord and the car, of a stopping lever hinged near its outer end to an arm of said bracket, and adapted to play in a slot at the inner end of said arm. 6th. In a store service apparatus, the combination, with the bracket, the track wire, and the car, of a stopping lever arched near its inner end, and means, substantially as described, for adjusting the downward pressure of the rear end of said lever. 7th. In a store service apparatus, the combination, with the bracket, the track wire, and the car, of a stopping lever having a flaring mouth, adapted to guide the upper wheel of said car into the groove on the lower edge of said lever. 8th. In a store service apparatus, the combination, with the bracket, the track wire, and the car, of a stopping lever pivoted near the outer end of said bracket, the rear end of which is provided with a series of holes, and its intermediate portion with a curve or arch, and a spring, one end of which is secured to said bracket, and the other end adapted to be engaged in either of said holes. 9th. In a store service apparatus, the combination, with the bracket, the track wire, and a car, adapted to be suspended from and propelled along said track wire, said car having secured thereto a horizontal collar open on one side to receive the neck of the cash or package receptacle, of a receptacle having a circular neck and retaining flange on the outside thereof, adapted to fit the shoulder in the upper portion of said horizontal collar. 10th. In a store service apparatus, the combination, with the track wire, of a bracket consisting of a U-shaped portion from one side of which extend two ends, and from the other a curved arm, the front arm of said U-shaped portion being slotted, an adjustment screw located in the rear arms of, and projecting through said slot in the front arm of the U-shaped portion of said bracket, and a swivel upon the end of said screw. 11th. In a store service apparatus, the combination, with the track wire and the pro-

PELLING cord, of a bracket consisting of a U-shaped portion from one side of which extend two ends, and from the other a curved arm, the front arm of said U-shaped portion being slotted, a spring pulley located in the lower portion of said bracket, and a string attached to said pulley and to the propelling cord.

No. 26,978. Portable Boat. (*Canot portatif.*)

Charles W. King, Kalamazoo, Mich., U. S., 17th June, 1887; 5 years.

Claim.—1st. The combination of the flexible covering having a folded loop in its upper edge, provided with loops to receive the upper ribs therethrough, and the upper ends of the cross-ribs therein, one or more detachable sections of elastic metal longitudinal ribs, the end bows, the upper ends being clamped between the covering and the keel-extensions, the bottom-keel provided with grooves and buttons, or equivalents, and cross-ribs of elastic metal, substantially as set forth. 2nd. The combination of a flexible covering, sections of elastic metal longitudinal ribs detachably placed in the covering, a detachable keel clamping the end-bows of said ribs between its bowed ends and the covering, and V-form elastic cross-ribs detachably attached at their upper end with the covering, and at the base with the keel, substantially as set forth. 3rd. A folding boat, in combination with the oar-support consisting of the bowed bars flaring apart at the base, thence extending upward joining each other, and provided with the oar-sockets and the side braces, all detachably connecting with the boat, substantially as set forth. 4th. A boat capable of being taken apart and folded into a bundle, consisting of a flexible covering having loops in its upper edge for receiving the longitudinal ribs therethrough, and the free ends of the cross-ribs therein, one or more sections of elastic longitudinal ribs detachable in the covering cross bows elastic and detachable and a keel, substantially as set forth. 5th. A boat having a flexible covering, provided with a detachable projection drawn over the base of the boat, substantially as set forth.

No. 26,979. Electric Motor. (*Moteur électrique.*)

James W. Easton, Reading, Penn., U. S., 17th June, 1887; 5 years.

Claim.—In an electric motor, the combination of an armature having polarized and neutral points, field-magnets acting upon the polarized points, which field-magnets have the central portions of their polar projections removed, and are thereby separated a greater or less distance from the neutral points of the armature, substantially as described.

No. 26,980. Hay Fork. (*Fourche à foin.*)

James W. Provan, Oshawa, Ont., 17th June, 1887; 5 years.

Claim.—1st. The combination, with the mechanism for operating the harpoon points of a double-pronged hay-fork, of a jointed lever adapted to fold at right angles to the prongs, substantially as and for the purpose specified. 2nd. A jointed lever connected to a crank-bar journaled on the prongs of the fork, in combination with rods arranged to connect the crank-bar with the harpoon-points of the fork, substantially as and for the purpose specified. 3rd. The combination, with the mechanism for operating the harpoon-points of a hay-fork, of a jointed lever attached to the crank-bar *C*, and adapted to fold at right angles to the length of the prongs, substantially as and for the purpose specified. 4th. The off-set crank-bar *C*, journaled on the prongs *A* and provided with the jointed lever *G*, in combination with the rods *E* and harpoon-points *F*, substantially as and for the purpose specified. 5th. The combination, with the harpoon-points, the prongs, and means for operating said points, of the bracket *H* secured to the cross-bar *B* and the latch *I* pivoted to said bracket and provided with a lever *J*, substantially as and for the purpose specified. 6th. The off-set crank-bar *C*, journaled on the prongs *A* and connected to the harpoon-points *F* by the rods *E*, a tongue *e* formed on the crank-bar *C*, in combination with the latch *I* pivoted at *d* between the sides of the bracket *H*, and connected to the trip-rope *K* by the trip-lever *J*, substantially as and for the purpose specified.

No. 26,981. Engine. (*Machine.*)

Perley Ainsworth, Rochester, N. Y., U. S., 18th June, 1887; 5 years.

Claim.—1st. The casing *B*, constructed of slightly elliptical form, with the greatest diameter in the horizontal line, as described. 2nd. The cylinder *A*, constructed with a slot or passage for the piston, and with cavities to receive friction rollers or balls, as described. 3rd. The shaft carrying the cylinder and eccentric to the exterior casing, with hubs recessed into the heads of the casing, in the manner and for the purpose specified. 4th. The piston composed of the several plates *c*, *c*₁, *c*₂, said plates being arranged in two series side by side with overlapping joints with springs *t*, *t*, whereby the piston is held in constant contact with the heads and periphery of the casing, substantially as shown and described. 5th. The cylindrical valve, constructed with a partition and so arranged, as described, in combination with the casing, as to open and close both the inlet and exhaust parts in starting, reversing, stopping, accelerating, or retarding the motion of the engine, as described. 6th. The combination, with the cylinder and the piston passing through the same, of a series of friction rollers or balls in the cylinder, and an opposite side of the piston, as and for the purpose specified. 7th. The combination of the piston *C*, composed of several plates *c*, *c*₁, *c*₂ and springs *t*, *t*, the series of rollers or balls *m*, *m*, and cylinder *A*, as and for the purpose set forth. 8th. The combination of the piston *C*, composed of several plates *c*, *c*₁, *c*₂ being arranged in two series side by side, with overlapping joints, and springs *t*, *t*, the cylinder *A* and the three-way valve *D*, substantially as shown and described. 9th. The combination of the casing *B*, cylinder *A* and compound piston *C*, composed of plates arranged in two series side by side, with overlapping joints, and the three-way tapering plug valve *G* having an opening *d* at one end communicating with the slot *g* for an exhaust, and having the longitudinal port *e* through which steam is admitted to the engine to propel it in either direction by oscillating the valve, as described.

No. 26,982. Device for Advertising on Wire Fences. (*Appareil pour annoncer sur les Clôtures en fil de fer.*)

Elijah K. Barnsdale, Stratford, Ont., 18th June, 1887; 5 years.

Claim.—In an advertising device, the combination of the fence wire with the pendant strips *g*, *g* secured thereto, and having the horizontal strips attached to their inner ends, upon which are secured the letters or figures, the several parts being united by means of the lap joint, substantially as described.

No. 26,983. Concealed or Flush Hinge.

(*Penure Affurée*)

Alexander M. Cawford, Campbell Hall, N. Y., U.S., 18th June, 1887; 5 years.

Claim.—A hinge consisting of three flat rectangular pieces of the same width and thickness but of different lengths, the ends of one of these pieces being square dove tailed or box-dovetailed into one end of each of the other two pieces, and held in place by and turning upon pins, the largest rectangular piece being set into a case and capable of being drawn outward and pushed inward in the case to a distance regulated by a slot in each side of the case, and a pin fixed in each side of the rectangular piece working in the slot, all substantially as set forth.

No. 26,984. Last. (*Forme de Chaussure.*)

John Donovan, Boston, Mass U.S., 18th June, 1887; 5 years.

Claim.—1st. In a last for stretching boots and shoes, the combination of the following instrumentalities, to wit: two toe-pieces adapted to be inserted in the forepart of the boot or shoe, said toe-pieces being hinged together at their rear ends, a nut loosely journaled on trunnions in the rear portion of said toe-pieces, an auxiliary screw adapted to be revolved in said nut but not to be with drawn therefrom, and provided at its inner or forward end with an adjustable nut or spreader, and at its rear end with a rigidly attached rosette, a main screw fitted to work longitudinally in said auxiliary screw, and provided with a rigidly attached rosette, and a heel piece adapted to be inserted in the heel portion of the boot or shoe, and to receive the end thrust of said main screw, substantially as described. 2nd. In a last for stretching boots or shoes, the toe-pieces A, B hinged together at *x*, and provided with the rocking nut P, in combination with the screw M, provided with the rosette *m*, said screw being adapted to be revolved in said nut but not withdrawn therefrom, and the nut or spreader D having the oval head *d* and adapted to be turned on said screw, substantially as set forth. 3rd. The heel-piece C having the gib or step *k*, in combination with the screw E, provided with the rosette J having the stud *t* journaled in said step, the screw M, nut P, hinged toe-pieces A, B and nut D, substantially as described. 4th. The heel-piece C having the rounded portion *l*, in combination with the auxiliary heel-piece H, substantially as set forth. 5th. The heel-piece C provided with the opening *x*, in combination with the pendulous arm *r* and card T, said arm being suspended from a rod resting in notches *p*, substantially as described. 6th. The improved stretching last herein described, the same consisting of the hinged toe-pieces A, B, the nut P journaled on trunnions *o* in said toe-pieces, the auxiliary screw M adapted to turn in said nut but be withdrawn therefrom, and provided with the rosette *m*, the oval shaped nut or spreader D disposed on the lower end of said screw, the main stretching-screw E provided with the rosette J having the stud *t* and fitted to work in the screw M, the heel-piece C having the gib *k* and opening *x*, and the pendulous arm *r* for carrying the card T, constructed, combined and arranged to operate substantially as set forth.

No. 26,985. Blackboard. (*Tableau Noir*)

Frank Russell, Oswego, N. Y., U.S., 18th June, 1887; 5 years.

Claim.—1st. A blackboard consisting of an endless fabric or band stretched upon rolls mounted upon standards, and a backing mounted upon said standards, and underlying a portion of the fabric, substantially as described. 2nd. A blackboard consisting of an endless fabric or band stretched upon rolls mounted upon standards, and a backing adjustably mounted upon said standards and underlying a portion of the fabric, substantially as described. 3rd. In a blackboard, the combination, with a fabric of slated cloth or other suitable material, of a rigid backing adjustably mounted beneath and giving support to a portion of said fabric, substantially as described. 4th. In a blackboard, the combination, with the standards, of the rolls supported there on the endless band of fabric stretched upon said rolls, the rigid backing F, thumb screws *d* and strip *e*, substantially as described.

No. 26,986. Truck for Moving Houses.

(*Chariot pour Transporter les Maisons.*)

Joseph Goodman, Sr., Frederick A. Goodman and Julius F. Goodman Detroit, Mich., U.S., 18th June, 1887; 5 years.

Claim.—1st. In a truck for moving houses, four trucks independently pivoted to the truck frame, and provided with two independent steering gears, one for the front trucks and one for the rear trucks, substantially as described. 2nd. In a truck for moving houses, the combination of a truck frame mounted on four independently pivoted trucks, of a steering gear for the front trucks, and of a draft attachment in the pivotal center of the front trucks, substantially as described. 3rd. In a truck for moving houses, in combination, a truck frame, four two wheeled trucks pivotally secured to the truck frame independently of each other, and having guide poles, cross-girts carrying rack-bars, carriages supported on said cross-girts and carrying a pinion and steering wheel, and of connection between the guide poles of the trucks and the carriages, substantially as described. 4th. In a truck for moving houses, in combination with a truck frame la-

terally adjustable and mounted on four two-wheeled trucks independently pivoted to said frame of two steering gears for each pair of trucks, each consisting of a rack bar mounted on a cross-girt, a carriage supported on said cross-girt, a pinion mounted on said carriage and carrying a steering wheel and adjustable connections between the carriage and the draft poles of the respective trucks, substantially as described.

No. 26,987. Dynamo Electric Generator.

(*Générateur Dynamo-Electrique.*)

James W. Easton, Reading, Penn., U.S., 18th June, 1887; 5 years.

Claim.—1st. The combination, with two field magnets and their respective armatures, the one organized to deliver currents constant in quantity, and the other to deliver currents of a constant electro-motive force and variable quantity, of a circuit derived from the armature delivering currents of constant quantity, including a portion of the field-magnet coils of the other armature, and a circuit derived from the last named armature including the remaining coils of its field-magnet. 2nd. The combination, substantially as hereinbefore set forth, of two armatures, one delivering currents constant in quantity and of variable electro-motive force, and the other delivering currents of constant electro-motive force, their respective field-magnets magnetizing-coils applied to both of said field-magnets, a circuit derived from the first named armature including all of its own field-magnet coils, and a portion of the field-magnet coils of the other armature including the remainder of its own field-magnet coils. 3rd. The combination of two armatures, their respective field-magnets, a circuit derived from one of said armatures including a portion of the field-magnet coils of the other armature, and circuit derived from the second armature including the remaining portion of said field-magnet coils and all the field-magnet coils of the first named armature.

No. 26,988. Self-exciting Alternate Current Electric Generator. (*Générateur Electrique Self-excitant à Courant Alternatif.*)

James W. Easton, Reading, Penn., U.S., 18th June, 1887; 5 years.

Claim.—1st. In an alternate current electric generator, the combination, with the armature coils, of the field-magnet coils having one terminal permanently connected with one terminal of the armature coils, and a circuit controller connecting the remaining terminal of the field-magnet coils directly with the remaining terminal of the armature coils during the generation of currents of a given polarity, and interrupting said connection during the generation of currents of the opposite polarity and at the same time connecting the terminals of the field-magnet coils directly with each other. 2nd. In an alternate current electric generator, the combination of an armature, two contact rings upon the shaft carrying said armature with which the respective terminals of the armature-coils are connected, contact brushes applied to the respective contact rings, a work circuit connected between said brushes, a circuit controller upon said shaft consisting of two insulated segments respectively connected with said contact rings, a brush making contact with the segments alternately, a connection from said brush with one terminal of the field-magnet coils, and a connection from the other terminal with one of the first named brushes.

No. 26,989. Method of preparing Malted Wheat, Oats and other Cereals (Barley excepted), and of employing them in the Manufacture of Bread and other Food.

(*Mode de preparation du Blé, de l'Avoine et des autres Céréales Maltés (excepté l'Orge) et de les employer pour la fabrication du Pain et autres Aliments.*)

Arthur B. Lester, London, and Albert Meaby, Reading, Eng., 18th June, 1887; 5 years.

Claim.—1st. A special method of preparing from malted wheats, oats, or other cereals (barley excepted) either separately or in combination, a very soluble, nutritious and easily assimilable meal or crushed cereal, containing the entire properties of the grain, such meal being adapted for all culinary purposes requiring very little cooking, and also for bread and biscuit-making and other purposes, as herein described and set forth. 2nd. The use of the aforesaid malted wheat, meal, or flour, with a proportion of ordinary flour in the preparation of bread, biscuits, and for the purposes, when the bran of the wheat is objected to as herein explained and set forth.

No. 26,990. Concrete Tile Moulding Machine.

(*Machine à Mouler les Tuiles en Béton.*)

Joseph Sabin, Mount Bridges, Ont., 20th June, 1887; 5 years.

Claim.—1st. In a moulding machine for making concrete tile, a frame A, in combination with the jacks E, E, substantially as shown and described and for the purpose set forth. 2nd. In a moulding machine for making concrete tile, the frame A, in combination with the jacks E, E and bar F, substantially as shown and described and for the purpose specified. 3rd. In a moulding machine for making concrete tile, the frame B, in combination with the sliding iron G, formed with slots H, H and rivets I, I, or their substantial equivalent substantially as shown and described and for the purpose set forth. 4th. In a moulding machine for making concrete tile, the gauges D, in combination with the frames or cases A, B, substantially as and for the purpose specified. 5th. The frame A, jacks E, E and bar F, in combination with the collars C, C, gauges D, frame B, sliding iron G, formed with slots H, H and rivets I, I, substantially as shown and described and for the purpose specified.

No. 26,991. Convertible Chair.

(*Fauteuil Brist.*)

Charles P. Kenna, Chicago, Ill., U.S., 20th June, 1887; 5 years.

Claim.—1st. In a convertible chair, the combination, with the seat frame, of the front legs pivotally connected therewith near the back, the extensible arms connected with the seat-frame and the rear legs connected with said extensible arms, substantially as described. 2nd. In a convertible chair, the combination, with the seat-frame, of the front legs pivotally connected therewith near the back, the extensible arms connected with the seat-frame in a manner free to slide, the rear legs pivotally connected to the extensible arms and the front legs, substantially as described. 3rd. In a convertible chair, the combination, with the seat frame, of the front legs pivotally connected therewith near the back, the extensible arms arranged to slide lengthwise, the seat frame, the rear legs pivotally connected with the extensible arms, and a swinging extension pivotally sustained with respect to the seat frame, substantially as described. 4th. In a convertible chair, the combination, with the seat-frame provided with rails, the extensible arms arranged to slide upon said rails, the swinging extension pivoted to said arms, the front legs pivoted to the seat frame near its back, the rear legs pivoted to the front legs and to the extensible arms, and provided with a suitable stop or bar for lifting the swinging extension, substantially as described. 5th. In a convertible chair, the combination, with the seat-frame having suitable rear legs, of the front legs pivotally connected with the seat frame, and provided near their lower ends and near their upper ends with sustaining wheels, substantially as described. 6th. In a convertible chair, the combination, with the seat-frame provided with suitable rear legs of the front legs in pivotal connection with the seat-frame, and provided near their lower ends with a set of small wheels and provided at their upper portions with a set of larger wheels and suitable standards for connecting said larger wheels with the legs, substantially as described. 7th. In a convertible chair, the combination, with the seat frame, of the front legs pivotally connected therewith near the back, and provided with two sets of wheels, and the rear legs pivotally connected to the front legs and extending below and behind the axles of the larger wheels to form guards, substantially as described.

No. 26,997. Gas Pressure Regulator.

(*Régulateur de la pression du gaz.*)

William H. Metcalf, New Haven, Conn., U. S., 20th June, 1887; 5 years.

Claim.—The float valve and graduating chain, in combination with a tube in which the interior space gradually diminishes upward, substantially as described.

No. 26,998. Galvanic Battery. (Pile galvanique.)

William P. Kookogey, Brooklyn, N. Y., U. S., 20th June, 1887; 5 years.

Claim.—The herein-described method of producing a battery solution, which consists in dissolving bichromate of potash or bichromate of lime in hot water, adding to the mixture sulphuric acid, then permitting the preparation to cool and stand, during which time the sulphate salt is crystallized and precipitated, then decanting the liquid from the precipitate, the materials being combined in substantially the proportions stated.

No. 26,999. Dish Washer. (Laveuse de vaisselle.)

Charles B. Saunders, Columbia, Mo., U. S., 20th June, 1887; 5 years.

Claim.—1st. In a dish-water, a rotating tray having adjustable racks on radial arms so as to be arranged for different sized plates, the said racks having obliquely disposed, so that the plates while resting therein will be in such a position that when the tray is rotated the water will strike the surface of the plates somewhat at an angle and properly cleanse them, substantially as herein set forth. 2nd. In a dish-water, the rotating tray provided with adjustable racks, and having obliquely-disposed recesses to receive therein the plates, and held in position by outwardly independent adjustable pieces, and an intermediate adjustable rack having obliquely-disposed transverse wires and rubber cushions so as to be gauged for different sized dishes, substantially as herein set forth. 3rd. In a dish-water, the rotating tray provided with radial arms B on the shaft, said arms notched at b, combined with the rectangular metallic frame F, the sides of which are somewhat at an angle, the outer edge recessed and set at an angle to receive the dishes therein, and the clips adapted to engage with the notched radial arms, substantially as described. 4th. In a dish-washer provided with radial arms having located inwardly therefrom an adjustable rectangular rack, and outwardly therefrom a hinged rectangular keeper, an immediately-disposed adjustable frame having obliquely-disposed metallic ribs with rubber tubing thereon, so that the said adjustable frame may act as a guard and keeper for the plates placed therein to prevent them from becoming broken while coming in contact with the side of the tray on being rotated, substantially as herein set forth. 6th. The combination of the axial piece A, the radial arms B and ribs E and the circumferential pieces C forming the frame with the adjustable rack F, the clips H and the rectangular hinged retaining-frame, substantially as herein set forth. 6th. The combination of the axial piece A, the radial arms B, ribs E, the circumferential pieces C forming a frame, the adjustable rack F, the clips H and the rectangular hinged retaining frame, with the intermediate frame a having the obliquely-disposed ribs d protected with rubber tubing e, substantially as herein set forth.

No. 26,992. Tool Handle. (Manche d'outil.)

Joseph W. Calef, North Easton, Mass., U. S., 20th June, 1887; 5 years.

Claim.—A tool-handle formed of a single wire made to form a passage for the arm at B, and twisted at C to give a hold for the hand, these parts B and C being separated by a straight portion A at one end, and another one D at the other, where a tool can be joined to it as above described and for the purposes set forth.

No. 26,993. Pruning Shears.

(*Ciseaux de jardinier.*)

Joseph W. Calef, North Easton, Mass., U. S., 20th June, 1887; 5 years.

Claim.—Double pruning shears H, G, with two cutting edges having shear holders C and E, provided with corresponding hand catches D, D1, and arm ring F, as above described and for the purpose set forth.

No. 26,994. Perpetual Calendar.

(*Calendrier perpétuel.*)

James S. Vine, Chicago, Ill., U.S., 27th June, 1887; 5 years.

Claim.—1st. In a perpetual calendar, a circular revolving tablet having disposed thereon radially two sets of monthly figures, one set being complete on one side or half the tablet, and the other set exactly the same on the other half of the tablet, in combination with the imprint on a stationary cord of the days of the week arranged around one half of the circular tablet, substantially as herein set forth. 2nd. In a perpetual calendar, a circular revolving tablet having disposed thereon radially a double set of monthly figures, one set on each half of the monthly tablet, as shown, in combination with a slitted card for receiving and covering one-half of the circular revolving tablet, substantially as herein set forth. 3rd. In a perpetual calendar, a circular revolving tablet having disposed thereon radially a double set of monthly figures, one set on each half of the tablet, in combination with a slitted card for receiving the circular tablet, said card having disposed around the circular tablet the successive names of the week, substantially as herein set forth.

No. 26,995. Hat Sweat. (Bande de chapeau.)

Franklin E. Randel, New York, N. Y., U.S., 20th June, 1887; 5 years.

Claim.—1st. The sweat leather or band provided with the free ends a1, a2, in combination with the supplemental piece b, secured to the hat at a point where the said ends meet, and the attaching means to fasten the two ends a1, a2 together, as set forth. 2nd. The combination, with a hat, cap or similar article, of the band a secured thereto so as to leave the free ends a1, a2, the supplemental piece b secured to the hat, the hook c, and re-enforce piece e upon end a1, and the holes a3, and re-enforce d secured to end a2, substantially as set forth.

No. 26,996. Gate. (Barrière.)

William F. Shedd, Grand Rapids, Mich., U. S., 20th June, 1887; 5 years.

Claim.—1st. The rods G and H arranged to fit together, provided with thread and nut, in combination with vertical rod F and gate B, substantially as and for the purposes shown. 2nd. The vertical rod F, provided with ring b, in combination with gate post A, gate B, and rods G and H, substantially as and for the purposes shown.

No. 27,000. School Desk and Seat.

(*Pupitre et banc d'école.*)

John C. Dobie, Mosa, Ont., 20th June, 1887; 5 years.

Claim.—1st. An adjustable school-seat consisting of seat B, supported on screws D, D turning in threaded sockets e by means of arms E, and provided with knobs or square-heads projecting through slots b in ends of frame as guides, so as to allow of the seat being raised or lowered, substantially as shown and specified. 2nd. In combination with the above, the front additional piece B1, hinged to rear part B and supported by braces c, c recessed in notches in frame A, substantially as shown and specified. 3rd. An adjustable desk G supported on screws H, H, turning in threaded sockets f, f by means of arms I, I, and provided with knobs or square-heads j projecting through slots c in frame at each end as guides, so as to allow of the desk being raised or lowered, substantially as shown and specified. 4th. In combination with the above, the front additional piece G1 hinged to back part G and supported by brace K recessed in notch in back of frame A, substantially as shown and specified.

No. 27,001. Jar Top Fastener.

(*Fermeture de bocal.*)

The Hemingray Glass Company, (assignee of Robert Hemingray), Covington, Ky., U.S., 20th June, 1887; 5 years.

Claim.—1st. An improved jar top fastener, consisting of a cone-shaped top fitting down upon a gasket or collar, and held in place by a spherical eccentric attached to the body of the jar, substantially as and for the purpose described. 2nd. In a jar top fastener, a spherical eccentric pivoted on a yoke or bale attached to the body of the jar, and fitting into a depression in the top, substantially as and for the purpose described. 3rd. The combination, with a jar, of a bale pivoted in a collar on the jar, and carrying a spherical eccentric arranged to be seated in a depression in the top of the jar, substantially as and for the purpose described. 4th. A conical-shaped jar top having a spherical depression in the apex, in combination with a spherical eccentric fastened to the jar, and arranged to be seated in said depression, substantially as and for the purpose described.

No. 27,002. Process of Cleaning, Repairing and Coating Metal Plates, etc.

(*Procédé de nettoyage, préparation et galvanisation des plaques métalliques, etc.*)

Francis J. Clamer and Joseph G. Hendrickson, Philadelphia, Penn., U.S., 20th June, 1887; 5 years.

Claim.—1st. The herein-described process of treating metal plates or other metal surfaces, consisting in cleansing the same by making them the anode in a cyanide bath through which a galvanic current is passing, then immersing them in a flux, and finally immersing them in a bath of molten metal, substantially as set forth. 2nd. The herein-described process of coating metal plates, or other metal surfaces, consisting in cleansing the same by making them the anode in a cyanide bath through which a galvanic current is passing, then immersing them in a flux, and finally immersing them in a bath consisting of lead or similar metal, sal ammoniac, arsenic, phosphorus and borax, or a similar flux, as set forth.

No. 27,003. Sectional Monument.

(*Monument sectional.*)

August H. Miller, Cleveland, Ohio, U.S., 20th June, 1887; 5 years.

Claim.—1st. A monument built in sections, and provided with a sectional connecting rod having a lock at its respective joints, whereby each section as erected may be tightened, substantially as set forth. 2nd. A sectional monument, each section having a cap-piece provided with a socket in the centre, in combination with a sectional connecting rod and a lock therefor to lock the cap-piece and thereby tighten the section it surmounts, substantially as set forth. 3rd. A sectional monument, each section of which is composed of separate plates, and each plate having notched lugs in which the meeting edge of the adjacent plate is held, in combination with cap-pieces, and a connecting rod to lock the parts together, substantially as set forth. 4th. In a sectional monument, the section plates provided with central openings and slotted lugs on the inside, in combination with panels to cover the openings, and cross-arms to fasten the panels, the vertical arms having a bevelled head at one end and tapered at the other end to enter said slots and lock the panels, substantially as set forth. 5th. In a sectional monument, a base or pedestal having a recess provided with sides converging toward the top thereof, in combination with a block formed with corresponding sides and adapted to be locked in said recess, said block having an opening for attaching the connecting rod, substantially as set forth.

No. 27,004. Two-Wheeled Vehicle.

(*Voiture à deux roues.*)

Henry G. M. Howard, Kalamazoo, Mich., U. S., 20th June, 1887; 5 years.

Claim.—1st. The body of a two-wheeled vehicle provided at the forward end with spiral springs anchored to the thills, and forming the only means of suspending the body, substantially as set forth. 2nd. The combination, with the thills, of a body or seat-bars terminating at the forward end in spiral springs parallel with the cross-bar, and suspended from the thills, the free ends of the springs contracting with the thills preventing them from rolling, substantially as set forth. 3rd. The combination of the body, terminating in spiral springs at the forward end, the thills provided with supports for the springs, and means for limiting the upward swing of the body, substantially as set forth. 4th. The combination of the thills, the body provided with the spiral having the free ends, and the adjusting blocks having the series of notches, substantially as set forth. 5th. The combination of the seat-bars, thills, spiral springs, and the two-part clamps attaching the seat-bars and springs together, substantially as set forth.

No. 27,005. Method of Discovering Short Circuits in Electric Machines.

(*Manière de découvrir les circuits courts dans les machines électriques.*)

James W. Easton, Reading, Penn., U.S., 20th June, 1887; 5 years.

Claim.—1st. The hereinbefore described method of detecting short circuits in electric machines, which consists in establishing an induced current in an independent circuit, by the variations in the magnetism due to the short circuit and in operating a signalling device by such induced current. 2nd. The combination, with a dynamo-electric or other generator, of an induction device applied to a pole of the field-magnet of the same, a closed circuit including such device, and an indicating device included in said closed circuit. 3rd. The combination, with a dynamo-electric or other generator, of a soft-iron core applied to the pole-piece of the same, a coil of insulating wire surrounding said core, a closed circuit including said coil, and a telephonic receiver included in said closed circuit. 4th. The combination, with a dynamo-electric or other generator, of a coil of insulated wire applied to a pole of the field-magnet of the same, at or near the point where the armature leaves the pole-piece, a closed circuit including said coil, and an indicating device included in said circuit, substantially as described. 5th. The combinations, substantially as described, with an electric machine, of an induction device, a circuit-controlling device for the field-magnet circuit, and an electrical device included in the circuit of the induction device for operating said circuit-controlling device to place the terminals of the field-magnet coil in connection with each other, substantially as described.

No. 27,006. Articles Manufactured for Pulp.

(*Objets en Pâte à Papier.*)

Frank B. Howard, Montreal, Que., 20th June, 1887; 5 years.

Claim.—As a new article of manufacture, a pulp-board provided with a pattern, substantially as and for the purposes described.

No. 27,007. Electric Battery.

(*Batterie Electrique.*)

Colin M. Thompson, Brooklyn, (assignee of Orazio Lugo, New York.) N.Y., U.S., 20th June, 1887; 5 years.

Claim.—1st. A galvanic cell in which the negative portion is provid-

ed with a separate substance, by which the elemental matter deposited in the action of the battery is removed, substantially as specified. 2nd. A galvanic cell in which the negative portion is provided with a separate substance, by which the elemental matter deposited in the action of the battery is removed, such substance forming with a portion of the battery. 3rd. An electric battery in which one element is immersed in an acid, and the other in an alkaline solution, one liquid containing a substance which will retard or nearly prevent inter-diffusion of the liquids, substantially as described. 4th. An electric battery in which the positive element is in contact with an alkaline solution, and the negative element with an acid solution, there being an interposed porous medium between the solutions, and the acid solution containing a metallic salt, whereby while the acid acts to keep the negative element free from deposit of objectionable elemental matter, thus obtaining a constant electrical energy or volt-ampere, the salt will prevent or retard the inter-diffusion of the solutions without preventing when the circuit of the battery is closed osmotic action of the gas through the porous medium, substantially as described. 5th. The method of decreasing or increasing the amperic current by changing the relative proportions of the acid and metallic salt around the negative electrode, substantially as described.

No. 27,008. Combined Latch and Lock.

(*Loquet et Serrure Combinés.*)

Charles Sandford, William Feeney, Jr., and James Feeney, Madoc, Ont., 20th June, 1887; 5 years.

Claim.—1st. In a combined latch and lock, the combination, with the case A a A1 of a reversible latch bolt B, neck B1, body B11, wedge tail B111, recesses p11, spindle hub C, cam C1, roller D, stud d, latch E, e, ridges a11, a111, slot a111, locking cam F, notch f11, keyhole k, facing k1, ridges k11 and ledge k111, substantially as set forth. 2nd. The combination, with the lock case A, of the bolt B, neck B1, body B11, shoulder b, perforations b1, recesses b11, wedge tail B111, roller D, stud d and spindle hub and cam C C1, substantially as set forth. 3rd. The combination of the case A, rim a, cam A1, stud d, ridges a11, a111, slot a111, facing k1, ridge k11, ledge k111 and keyhole K, substantially as set forth. 4th. The combination, with a latch bolt B, of the neck B1, body B11, opening b1, recesses b11 and wedge tail B11, substantially as set forth. 5th. In a combined latch and lock, the combination, with a bolt B having neck B1, body B11, shoulder b, opening b1, recesses b11 and tail B111, of the casing A, a hub and cam C, C1, stud d, roller D cam F f11, keyhole k, facing k1, ridge k11 and ledge k111, substantially as set forth. 6th. In a combined latch and lock, the combination with a bolt B having neck B1, body B11, shoulder b, opening b1, recesses b11 and tail B111, of the casing A, a A1, cam C1, stud d, roller D, latch E e and ridges a11 a111, slot a111, substantially as set forth. 7th. In a combined latch and lock, the combination of a casing slidingly supporting in its rim the light front end of a latch bolt, a reversible bolt having an opening admitting the spindle hub and cam, its rear end made heavy and recessed to form a wedge shaped tail supported upon a friction roller, the recesses forming said tail allowing the circular movement of a locking cam or tumbler adapted to be engaged and moved in a circular race formed by concentric ridges around the keyhole by a keybit, and to rest upon a ledge in the case or about between the wedge shape tail the ledge and the race rim, substantially as set forth.

No. 27,009. Machine for Grinding Horse Shoe Calks.

(*Machine à Rémouler les Crampons des Fers à Cheval.*)

Henry East, Daniel C. Priece and Henry R. East, Rochester, N.Y., U.S., 20th June, 1887; 5 years.

Claim.—1st. In a machine for grinding horse-shoe calks, the combination, with the frame of the machine, of an arm projecting therefrom and capable of turning axially a grinding wheel on the outer end of the arm that can be turned to any angle by turning the arm, a pulley on the axis of the grinding wheel, and a band giving motion to the pulley, as set forth. 2nd. In a machine for grinding horse-shoe calks, the combination, with the frame of the machine, of an arm projecting therefrom and capable of turning axially a grinding wheel and pulley at the outer end of the arm, grinding pulleys on the sides of the frame running loosely in inclined studs that allow free sliding movement of the pulley out and in, a large pulley above the side pulleys and a single band passing over the main pulley, thence down and around the side pulleys, and thence around the pulley on the shaft of the grinding wheel, as shown and described and for the purpose specified. 3rd. In a machine for grinding horse-shoe calks, the combination, with the pulley D on the turning shaft B and with the main driving pulley G, of side pulleys E, E resting loosely on studs b, b so as to slide freely out and in, and the single band k passing around said pulleys, whereby as the shaft is turned the pulleys E, E will slide on the studs to compensate for the twist of the pulley D, as set forth.

No. 27,010. Curtain Fixture.

(*Gousset Porte-rideau.*)

Low R. Strang, Sydney Hutchings and Sydney S. Sylvester, Gloucester, Mass., U.S., 20th June, 1887; 5 years.

Claim.—1st. In a certain-fixture of the character described, the combination of a bracket adapted to be attached at its inner end to the stile or rail of the sash, a slide carried by said bracket and adjustable longitudinally thereon, and a bar for supporting the bracket or holder in which the slide, and is journaled, said bar being adjustably mounted in said slide, and adapted to project over a portion of the window casing, substantially as described. 2nd. In a certain fixture of the character described, the bracket C provided with the flange m, the slide D provided with the slot r, flange v, mortise k and screws g, z, and the bar E, provided with the arm b and slots d, combined and arranged to operate substantially as set forth. 3rd. In a certain fixture of the character described, the bar E provided with

the arm *b* having the slots *d* and groove *h*, in combination with the screw *i* and nut *l* for supporting the bracket in which the shade-roll is journaled, substantially as described.

No. 27,011. Valve Attachment for Steam Cylinders. (*Disposition aux Soupapes pour Cylindres de Vapeur.*)

Léandre Boudreau and John J. Gorman, Thibodeaux, La., U.S., 22nd June, 1887; 5 years.

Claim.—1st. An attachment for steam-cylinders, the same consisting of a valve chamber having a valve-seat and a discharge below the same, a spindle having a limited vertical movement in the attachment, a valve on said spindle, and a spring for throwing said valve from its seat the attachment being cut away on one side below the discharge for the removal of sediment, substantially as set forth. 2nd. In an attachment for steam cylinders, a valve-chamber having a valve-seat and discharge below the same, a spindle having a limited vertical movement in said attachment, a valve on said spindle, and a spring located in the lower part of said attachment and adapted to throw the valve away from its seat, said attachment being cut away adjacent to said spring, and a cap or case for embracing the lower portion of the attachment to close or cover the cut-away portion of the same, substantially as set forth.

No. 27,012. Ratchet Wrench.

(*Clé à écrou à rochet.*)

David H. Stewart, (assignee of John W. Day), York Sulphuric Springs Penn., U.S., 22nd June, 1887; 5 years.

Claim.—The combination of the stock, the rotary flat sided head pivoted thereto and carrying the adjustable jaws, said jaws and head having a width not greater than that of the stock, the ratchet-wheel rigidly connected with the rotary head, two pawls pivoted in the stock and engaging the ratchet wheel on opposite sides, and a camming by which either of said pawls may be disengaged from the ratchet-wheel, substantially as shown and described.

No. 27,013. Automatic Car Coupler and Uncoupler. (*Attelage Automatique de Chars.*)

John H. Flett, Galveston, Texas U.S., 22nd June, 1887; 5 years.

Claim.—1st. In a car coupling, the combination, with a slotted draw head, of two jaws pivotally mounted therein and a lever in the slot of the draw head and carrying a block engaging the rear ends of the jaws to hold them closed, substantially as herein shown and described. 2nd. In a car coupling, the combination, with a draw-head, of jaws 13 and 14 mounted upon pivot pins or bolts, the jaw 13 and 14 mounted upon pivot pins or bolts, the jaw 14 being formed with a recess 23, a lever 20 mounted within a slot formed in the draw head, a locking block or dog carried by the lever and a lever operating mechanism, substantially as described. 3rd. In a car coupling, the combination, with a draw head formed with recesses 12, 15, 16 and 17, of coupling jaws pivotally mounted within the recess 12, said jaws being formed with recesses 25, 27 and 28, a plate 40 mounted within the recesses 25, a locking dog mounted in the recess 17 and arranged to enter the recess 15, and a recess formed in the heel of one of the coupling jaws a lever upon which the locking dog is mounted and a spiral spring connected to the lower jaw and to the lever and a lever operating mechanism, substantially as described. 4th. In a car coupling, the combination, with a draw-bar and its head formed substantially as described, of coupling jaws pivotally mounted within the draw head, a lever and a locking dog carried thereby, a plate 40 carried by the jaws, a spring 24 or weight connected to one of the jaws and to the lever, the lever 43 and a chain 44 connecting said levers and operating chains leading from the lever 43 to the top and side of the car, substantially as described. 5th. The combination, in a car coupler, of an uncoupler comprising a weight supported on the car and in connection with the coupler, whereby when the weight is released from the car by the derailing of the car or otherwise, the coupling will be released or its parts disengaged and the cars separated, substantially as set forth. 6th. The combination, with a coupling adapted to hold two cars together, of an uncoupler comprising, a lever pivotally connected to the car, a weight supported on the car and connected to said lever, and a connection between the weight operated lever, and the coupling for operating it to separate the cars upon the dropping of the weight, substantially as described. 7th. The combination, with a movable coupling jaw and the lever for operating the same of an uncoupler comprising a weight supported on the car and connected to said lever, whereby when the weight is released and falls the lever will be moved and the coupling jaw operated, substantially as set forth. 8th. The combination, with a car coupler, of an uncoupling device comprising a bracket having a shallow rounded open recess or socket, a weight having a rounded surface and resting loosely in said recess or socket, and a connection between said weight and the coupling proper, whereby the weight may be readily unseated by derailment of the car and release or disengage the coupling by its fall and thereby separate the car, substantially as set forth.

No. 27,014. Machine for Pearling Barley, Wheat, etc. (*Machine à perler l'orge, le blé, etc.*)

Cyrus O. Webb, Moravia, N.Y., U.S., 22nd June, 1887; 5 years.

Claim.—1st. A machine for pearling barley, wheat, and the like, consisting of a revolving shaft, emery-wheels mounted thereon, a casing exterior to the emery-wheel, and adapted to revolve by friction of the grain between the said wheels and its interior surface, said casing being provided at its discharge end with lifting-arms for the discharge of the grain when the casing revolves, substantially as described.

No. 27,015. Harness. (*Harnais.*)

Frank L. M. Granier, Raymond, Ill., U.S., 22nd June, 1887; 5 years.

Claim.—1st. The combination, with the trace, of the adjustable pad-loop E having a series of smaller loops *c* arranged the upper side thereof, by which the collar or harness-saddle may be adjusted, substantially as described. 2nd. The combination, with a trace, of an adjustable trace attachment consisting of a looped metallic spring-plate C, having a stud or pin *e* on its one side passing through apertures in the trace and plate, and secured by a wire spring C₁ attached to the outer side of said metallic plate, substantially as described. 3rd. The combination, with the trace, of an adjustable metallic spring-plate secured to said trace by means of a loop B, a stud or pin *e* secured to one side of said metallic looped plate, and passing through the trace and the other side of the plate, and a wire spring C₁ secured to the looped plate at one end and engaging the apertured end of the stud or pin at its free end, substantially as described. 4th. A trace attachment adjustable on the trace consisting of a metallic looped plate engaging with each side of the trace having a stud secured at one end passing through the trace and through an aperture in the other end of said plate, a securing-loop B for attaching the metallic plate to the trace, and a wire spring engaging with the apertured end of the adjusting pin or stud, and adapted to release the said attachment entire from connection with the trace and allow it to be adjusted to lengthen or shorten the trace, substantially as described. 5th. A trace comprising an adjusting pad-loop E, provided with a series of smaller loops *c*, and an adjustable spring looped plate C engaging with the end of the trace, whereby the harness-saddle and the trace may be adjusted and regulated for use in connection with horses of varying sizes, substantially as described.

No. 27,016. Harrow Cultivator.

(*Herse-scarificateur.*)

John A. Bunn, Cayuga, Ont., 22nd June, 1887; 5 years.

Claim.—1st. The combination, with the main beam A and tooth J, of tooth-holder D having a socket G at the side to intersect the tooth, and a tapering bolt H provided with a nut I to clamp the tooth and main beam in the tooth-holder, as set forth. 2nd. The tooth-holder D having intersecting sockets E, F and G, and shoulders K, K, as and for the purpose set forth.

No. 27,017. System of Heating Railway Cars. (*Système de chauffage des chars de chemin de fer.*)

Joseph Elder, Peoria, Ill., U.S., 22nd June, 1887; 5 years.

Claim.—1st. In a system for heating railway cars, a car provided with a series of water circulation pipes having terminal couplings and terminal valves by which they may be opened and closed at will, in combination with a steam boiler located at a station and provided below the water line with a discharge pipe having a valve, and a coupling adapted for connection with the car pipe, and a receiving tank also located at the station and provided with a pipe adapted to receive the water discharged from the car, whereby the hot water may be delivered from the boiler into the car pipes, and the cooler water delivered from the latter into the receiving tank. 2nd. In a station apparatus for supplying railway cars with hot water, and at the same time removing the cooled water therefrom, the steam boiler provided with the water delivery pipe having a series of flexible branches, each branch with a coupling and a stop-valve, in combination with the receiving tank having the series of receiving branches, the pipes connecting the boiler and tank, and the pump or similar means for delivering the water from the tank to the boiler, whereby the steam pressure is rendered available to deliver the hot water into, and the cooler water out of, a number of cars at one time, and the return of the partly cooled water to the boiler effected thereafter. 3rd. In combination with a railway car, provided with water circulating pipes, and with valves for closing their ends, a water-supply pipes, a coupling for connecting the same with the car pipe, and devices, substantially as described, whereby the application of the coupling at one end of the car effects the opening of the valve at the other end. 4th. The circulating pipes provided with valves K at opposite ends, in combination with the devices connected to one end of said valves to open the same, and extended to opposite end of the car, and the separable coupling adapted to operate said valve opening devices. 5th. The railway car provided with a water circulating pipe, having the elevated arched portion extending from one side to the other, whereby the lower portion of the pipes are kept constantly full of water. 6th. The railway car having the system of hot water pipes extended beneath its floor, in combination with the registers located over the pipes in alternating positions, as described and shown. 7th. The steam boiler provided with a delivery pipe below the water-line, said pipes provided with a series of branches, each branch having a flexible terminal coupling thereon, and a valve by which it may be opened and closed at will, whereby hot water may be delivered at will forcibly into a number of cars simultaneously, the delivery to each car being effected and controlled independently.

No. 27,018. Manufacture of Phosphorescent Substances. (*Fabrication des substances phosphorescentes.*)

James H. Thorp, New York, N.Y., U.S., 22nd June, 1887; 5 years.

Claim.—1st. The herein-described luminous compound or substance composed of ground marble and pulverized gypsum or Keene's cement as a base, combined with the herein-described dry luminous composition formed of sulphur, borax, alum, rock-salt, pulverized marble and phosphorescent powder mixed together, substantially in the proportions named, and united and solidified by dampening or wetting the same with a chemical solution formed of water, lime and silicate of soda, substantially as and for the purpose set forth. 2nd. The herein-described luminous compound or substance, composed of ground marble and pulverized gypsum or Keene's cement as a base,

combined with the herein-described dry luminous composition formed of sulphur, borax, alum, rock-saft, pulverized marble and phosphorescent powder, substantially in the proportions named, and mixed with a suitable vehicle, substantially as and for the purpose set forth.

No. 27,019. Wrench Attachment.

(Clé à écrou.)

William A. Kelly and Charles H. Hubbell, East Tawsa, Mich., U.S., 22nd June, 1887; 5 years.

Claim.—1st. The movable wedge block B having the small end bifurcated, as shown, to prevent lateral movement when attached to the movable jaw of the wrench, substantially as herein set forth. 2nd. The block B, forked spring C and movable D, all combined substantially as herein set forth.

No. 27,020. Fire-Arrêter for Stove Pipes and Smoke Stacks. (Garde-tincelle pour tuyaux de poêles et cheminées.)

Philip Williams, Huntsville, Ont., 22nd June, 1887; 5 years.

Claim.—1st. The combination of the metal taper pipe A, with its solid cap B and its adjustable cap E, and the holes G. 2nd. The bar D and the threaded rod E. 3rd. The diaphragms C C, all substantially as and for the purpose hereinbefore set forth.

No. 27,021. Manufacture of Artificial Teeth and apparatus employed therefor. (Fabrication des dents artificielles et appareil pour cet objet.)

George H. Jones, London, Eng., 23rd June, 1887; 5 years.

Claim.—1st. A mould consisting of front plate a and back plate b, the front plate being provided with irregularly shaped cavities c having irregular bevells d or their equivalents, and recesses e or their equivalents, and the back plate having studs or pins f, irregular cavities g, and irregular raised bevells h, all substantially as set forth and shown at Fig. 1 and 2. 2nd. Forming artificial teeth with multi-form bevelled edges or sides both on the front and back, substantially as set forth and shown at Fig. 3 and 5. 3rd. Fitting one or more artificial teeth either in a denture or on the gum so that they overlap or interlock and fit in either before or behind each other, or upon or between the natural teeth, all substantially as described and shown at Fig. 3.

No. 27,022. Stocking and Mode of and Means for Knitting the Same. (Bas et mode et moyens de les tricoter.)

Edgar C. Covell and Elisha S. Cram, Laconia, N.H., U.S., 23rd June, 1887; 5 years.

Claim.—1st. The needle-cylinder and needles, the stitch and loop-wheel and its support, and a pattern belt or band adapted to operate on said stitch-wheel support to regulate or control the position of the stitch-wheel with respect to the needles to lengthen or shorten the stitches, the whole arranged, combined and operating as and for the purposes specified. 2nd. The needle-cylinder and needles, the yarn guides, the stitch or loop-wheel constructed to take the yarn from the yarn-guides and feed it under the beard of the needle, and a support for said loop-wheel, a pattern belt or band, a system of levers intermediate of said stitch-wheel support and said pattern belt, the latter being adapted to operate on the levers to gradually regulate or control the position of the stitch with respect to the needle-stitch by stitch and course by course, to lengthen or shorten the stitches, the whole arranged, combined and operating as and for the purposes set forth. 3rd. The combination, with the needles and their cylinder or head, a stitch-wheel, a supporting rod for the same, a spring for normally holding said stitch-wheel, and its supporting-rod pressed toward the needles, a lever engaging one end of the stitch-wheel supporting rod, a sprocket wheel, a pattern chain on said wheel adapted to engage the other end of said lever and draw the stitch-wheel backward from the needles, and means for rotating needle-cylinder or head, and said sprocket wheel, substantially as and for the purposes set forth. 4th. The combination, with the needle-cylinder and needles, of a knocking-over wheel Z, a support therefor, a spring for holding the knocking-over wheel passed yieldingly toward the needles, as set forth. 5th. The combination, with the needle-cylinder and needles, of the stitch-wheel, means substantially as described, for gradually varying the position of the stitch-wheel with respect to the needles, and a knocking-over wheel and its support, and a spring for holding the knocking-over wheel pressed yieldingly toward the needles, as set forth. 6th. The combination, with the needle-cylinder and needles, of a take-up head, a pull-up cord or chain attached to said take-up head, and a weight m attached to said cord or chain, as set forth. 7th. The combination, with the bed or frame, the needle-cylinder and needles of a pull-up cord or chain, a wheel o around which said cord or chain is adapted to pass, said wheel having a rim provided with notches o₁, an arm r pivoted to the frame and provided with a wheel or bowl q, a spring r₁, a pawl s, and link s₁ connecting said arm with said pawl, as set forth. 8th. The combination, with the bed or frame, the needle-cylinder and needles, of a pull-up cord or chain, lever or arm r, pivoted to the bed or frame and provided with roller or wheel q, a spring r₁, and a finger s₁, as set forth. 9th. The combination, with the bed or frame, the needle-cylinder and needles, gear f on the needle-cylinder, the driving-shaft, gearing connecting said gear f with the driving shaft, and shipping mechanism for disconnecting said gear from the driving shaft, of a pull-up cord or chain, a wheel o provided with ratchet notches o₁, arm r, bevel or roller q, pawl s, link s₁, spring r₁, forked rod t, and mechanism intermediate of said rod and said shipping mechanism, as set forth. 10th. The combination, with a pull-up cord or chain, provided with swell loops or links, of a forked sliding rod t provided with a roller or bowl s₂, the needle-cylinder having a gear f, the driving shaft, a gear thereon, shipping

mechanism for connecting the former gear with and disconnecting it from the latter gear, and devices intermediate of said rod t and shipping-mechanism, as set forth. 11th. The combination, with a needle-cylinder and needles, and mechanism for operating the same, a shipping or stop-motion mechanism for stopping the operation of the cylinder, mechanism for operating and controlling the operations of said shipping or stop-motion mechanism, a bracket j located in the rear of the needle-cylinder for supporting said mechanism for operating and controlling the operations of the shipping or stop-motion mechanism, as set forth. 12th. The combination with the needle-cylinder and needles, the stitch-wheel and its support for holding it yieldingly pressed toward the needles, pull-up cord or chain n, bracket j, wheel o, shaft k, wheel kr, chain cr and lever l provided on its lower end with roller or bowl l₂ and connected at its upper end with the stitch-wheel support, as set forth. 13th. A stocking having a round seamless heel and toe and seamless foot and leg portions, the foot portion of the leg being knit with a comparatively short or close stitch, and the calf portion of the leg being knit with a comparatively long or loose stitch, the completed stocking having a single seam N O uniting the edge of the heel portion to the main web, substantially as set forth. 14th. The improvement in the art of knitting and completing a stocking, which consists in picking or running on the needles, a course of stitches, of a round or hemispherical toe-piece taken one or more courses from the edges, knitting the foot portion with a comparatively short or close stitch to the line where the heel is to be joined to the main web, then picking or running on a sufficient number of the needles, a course of stitches of a round or hemispherical heel piece taken one or more courses from one of the edges of said heel piece, then knitting the ankle portion with a comparatively close stitch, and the calf portion with a comparatively loose or long stitch, then cutting across the foot-web just below the line where the heel-piece is joined to the main web, then uniting the lower or forward edge of the heel-piece to the rear edge of the sole part of the foot portion, as set forth. 15th. The art of knitting a tubular fabric of varying diameter on a circular spring-needle knitting machine, which consists in gradually and regularly varying the position of the stitcher loop-wheel with respect to the needle stitch by stitch and course by course as the knitting progresses to vary the length of the stitches and consequently the diameter of the tube, as set forth.

No. 27,023. Machine for Registering Votes. (Machine à enregistrer les votes.)

(Machine à enregistrer les votes.)

Peter E. Jones, Hagerville, Ont., 23rd June, 1887; 5 years.

Claim.—1st. The combination of the lever d with the weight of a ball dropped upon d, substantially as shown and described. 2nd. The combination of the wheels g f actuated the dog f and the pin i which registers each movement upon the dials m and k, as shown and described.

No. 27,024. Machine for Unloading Hay. (Machine à décharger le foin.)

(Machine à décharger le foin.)

James Henderson, Mitchell, Ont., 23rd June, 1887; 5 years.

Claim.—1st. The lock bolt P C D having the projections A, B, notch E and space R, substantially as and for the purpose hereinbefore set forth. 2nd. In combination with the lock bolt P C D, with the projections A, B, notch E and space R of the stop block, bed piece F having the strip M, G, N, substantially as and for the purpose hereinbefore set forth.

No. 27,025. Wheel Rake. (Râteau à cheval.)

Bowden Chapman, Shemogen, N.B., 23rd June, 1887; 5 years.

Claim.—1st. In a horse rake tooth, the arm G, in combination with tooth C and fastened with hook-bolt N, as shown and described for the purpose set forth. 2nd. The axle E, as described, in combination with the arm G and thill coupling K. 3rd. The axle-bolt I, in combination with the arm C having tooth C fitted as shown and described. 5th. A tooth C, bent at right angles at O and fastened to an arm G, and movably fastened by the axle-bolts I, as shown and described. 6th. In a horse rake having arm C and press-bars D, the short teeth R on each side of the rake, as shown and described. 7th. The two-part axle E joined by axle bolts I and controlled by trip-lever B fastened in notches L of support F, all combined as shown and described for the purpose set forth.

No. 27,026. Gas or Vapour Engine. (Machine à gaz ou à vapeur.)

(Machine à gaz ou à vapeur.)

Arthur Rollason, London, Eng., 23rd June, 1887; 5 years.

Claim.—1st. A gas or vapour engine arranged to utilize heat generated by a prior explosion, in order to raise the temperature of a subsequent charge, in the manner hereinbefore described. 2nd. A gas or vapour engine arranged to prevent the loss of heat at or about the moment of the explosion of the charge, in the manner hereinbefore described. 3rd. A three-cycle gas or vapour engine provided with means for maintaining the temperature of the walls of the compression and ignition chamber, substantially as hereinbefore described. 4th. A gas or vapour engine, having a cylinder provided throughout the portion in which the piston works with a water-jacket and having a compression and ignition space provided with means for maintaining the temperature of the walls thereof, the engine being arranged so as to draw in and expel a cooling charge, and then to draw in and compress an explosive charge, the combustion of which is practically complete at the moment of ignition, substantially as hereinbefore described. 5th. A gas or vapour engine having an air space surrounding the compression and ignition chamber, as hereinbefore described. 6th. A gas or vapour engine, arranged so that at the moment of ignition the weaker part of the combustible mixture shall surround the point of ignition and the richer part of such combustible mixture shall be further away from the point of ignition, substantially as hereinbefore described. 7th. The use in a gas or vapour engine, of means such as are hereinbefore described and il-

instated, for securing the intimate mixture and incorporation of the gas or vapour and air, with the object of securing complete combustion and enabling a more dilute charge to be used. 8th. The arrangement of gas or vapour engine hereinbefore described and illustrated by the drawings, by means of which the weaker part of the mixture is caused to surround the firing point at the moment of ignition and the intimate mixture and incorporation of the gas or vapour and air is provided for. 9th. The provision, in combination with an arrangement for permitting the use of a more than ordinarily dilute mixture such as is hereinbefore described, of a separate gas slide in connection with the governor for the variation of the gas or vapour supply as required, so as to admit a more or less diluted mixture to the cylinder, substantially as hereinbefore described. 10th. In a three-cycle gas or vapour engine, the combination with a cylinder provided with a compression chamber having air-space $\alpha 2$ of admission orifice with parallel sides, and a gas admission port and valve so arranged that the effective area of admission is varied throughout the stroke in proportion to the varying velocity of the piston, as and for the purposes set forth. 11th. In a three-cycle gas or vapour engine constructed and arranged on the principles hereinbefore set forth and claimed, the combination with a cylinder, compression chamber having space $\alpha 2$, admission port with parallel sides, and gas admission port and valve adapted to vary the effective area of admission in proportion to the varying velocity of the piston, of a separate gas slide arranged substantially as and for the purposes hereinbefore set forth.

No. 27,027. Electric Fence, etc.

(Clôture électrique, etc.)

David H. Wilson, Chicago, Ill., U.S., 23rd June, 1887; 5 years.

Claim.—1st. In a wire-fence, the combination of a magneto-electric generator, a circuit composed of a wire leading from one pole of the generator, and connected with an electric bell mounted on a switch-board, a switch G G' connected with said bell, a switch B B' leading from the other pole of the generator, or two series of sockets in the switch-board, one series for each switch, and the fence-wires, each of which wires leads to a socket in each series, the circuit being established by said switches and sockets, and short switch-wires crossing said fence wires, substantially as described and for the purpose set forth. 2nd. The combination of two or more fence-wires insulated from the earth, whose ends terminate at an indicator-board with devices by which the fence-wires can be put in an electric circuit, and short switch wire or wires, as S, Sr, etc., connecting the fence-wires together, substantially as and for the purpose set forth. 3rd. The combination of the fence-wires, an indicator to which the ends of the wires are connected, and by which they are insulated from each other, a device for connecting the two ends of the same wire or of different wires in the same electric current, switch-wires connecting the wires together between their ends and gates in the fence forming a continuous connection with the wires when closed, but breaking the circuit when open. 4th. In a fence having insulated wires charged with electricity, and gates therein, and connected with an electric bell and generator, substantially as set forth, of a ground-connection thrown into the circuit by the opening of the gate, substantially as and for the purpose set forth. 5th. In a fence having insulated wires charged with electricity, gates therein which when opened make a ground connection through rods pivoted in projections in the gate posts, and spring formed in the fence-wires for closing in said gates when released, as and for the purposes set forth. 6th. In a fence having insulated wires charged with electricity, and gates therein, rods pivoted to the gate-posts having projections $\alpha 1$ impinging against said gates and springs $\alpha 2$, the said gates when opened bringing said springs in contact with the fence-wires making a ground-connection, as and for the purposes set forth. 7th. The combination of two or more insulated wires charged with electricity, whose ends terminate at an indicator board, with devices by which the charged wires can be put in electric circuit, switch-wires S, Sr, etc., connecting the charged wires together, substantially as set forth, and a railway having a spring-knob T electrically connected to a charged wire, as α , and arranged to be forced down by a wheel passing along the rail, and thus making ground-connection with the said wire, substantially as and for the purpose set forth.

No. 27,028. Horse Shoe. (Fer à cheval.)

The Improved Horse Shoe Company, New York, (assignee of Lyman B. Melius, Copake, N.Y., U.S., 23rd June, 1887; 5 years.

Claim.—1st. The combination, with a horseshoe of a removable calk, the said calk being secured together by an angular lug having substantially parallel sides, and formed in one piece with the calk, and extending into the shoe, and a pin located between the opposing faces of the shoe and calk on one side of lug, and forming a dove-tail joint both with the shoe and the calk, substantially as described. 2nd. The combination, with a horse-shoe of a removable calk, the said shoe and said calk being secured together by an angular inclined lug having substantially parallel sides, and formed in one piece with the calk and extending the shoe, and a pin located between the opposing faces of the shoe and calk and forming a dove-tail joint both with the shoe and the calk, substantially as described.

No. 27,029. Railway Car.

(Char de chemin de fer.)

Azariah B. Harris, Springfield, Mass., (assignee of Gustave Leve, New York, N.Y., U.S., 23rd June, 1887; 5 years.

Claim.—1st. A sleeping-car having a series of recesses 5 in its inner side walls, and a series of bed-lockers hinged to said side walls at one side of said recesses, and shutting over the latter, substantially as set forth. 2nd. The two lockers hinged to the side of the car in vertical positions, and constituting when opened the ends of the sleeping compartment, and the bar 15 pivoted to one of said lockers, and having a hook on its free end engaging with a suitable bolt on the opposite locker, said bar constituting both a brace for holding the lockers firmly in an open position and a curtain-rod, combined and operating substantially as set forth. 3rd. The case 17 secured on the side of

the locker, the catch 16 pivoted in said case and having a suitable spring thereunder, and the rod 15 hung on said locker and having its free end engaging with said catch, all combined as set forth. 4th. The upper bed-frame having wide headed bolts in the ends of the side rails at one end of the frame, the bed-locker having grooves 23 in the inner opposite side thereof, in which the heads of said bolts engage and have a sliding motion and the spring actuated shaft 24 having a winding-drum thereon near each end, and a metallic ribbon for each drum connected to the latter and to the end of said bed-frame, combined and operating substantially as set forth. 5th. The combination, with a swinging-berth cupboard, of a berth-frame made up of side rails and cross-bars and slots, a spring-pulley attached to said cupboard, a ribbon or cord working on said pulley and attached to said berth-frame, and means for holding the latter in a horizontal position, substantially as specified. 6th. The combination, with the bed-lockers 4 of a sleeping-car, of bed-frames therefor supported only by their ends on said lockers consisting of the wooden side rails 19 re-enforced by the longitudinal metal plate 20 secured on the side of each rail, the series of metal cross-slats 21, and longitudinal bars 22 near each end of the frame, and the canvas center 230 secured to the two inner cross-slats 21 of the frame, substantially as set forth. 7th. In combination, the locker 4 having the slots 23 in the sides thereof, the upper bed-frame having one end pivoted to and sliding in engagement with said slots, the lower bed-frame pivoted to the inner opposite sides of the locker between said grooves and the edges of the locker, and swinging into the latter outside of the upper bed-frame, and means, substantially as described, for temporarily securing the upper ends of said frames in the locker, substantially as set forth. 8th. The combination, with the locker 4 and the upper bed-frame, of the case 34 fixed in the side of the locker, and the spring actuated catch 33 pivoted in said case, substantially as set forth. 9th. As means for supporting the bed-locker when it is opened, the leg 9 hinged to the lower end of the latter having therein the central bolt 12 and the screw-coupling 11 on its lower end, combined with the plate 10 secured to the floor of the car, which serves as a step for said bolt and with which said coupling engages, substantially as set forth. 10th. The combination, with the locker 4, of a rail-support adapted to fold up flush with the cupboard face, substantially as and for the purpose set forth. 11th. The bracket-cases 26 secured in the outer side of the locker, and each provided with a pivoted bracket 25 to swing outwardly from and into said case, a spring-actuated stop 31 also pivoted in said case above said bracket, a tongue 28 pivoted in said case behind said bracket and bearing on the rear end of the latter, and a spring 29 acting against said tongue, combined and operating substantially as set forth. 12th. combination, the bracket-case 26, the bracket 25 pivoted in the latter and having the stud 132 and the post and roller 27 thereon, the spring-actuated tongue 28 pivoted in said case back of said bracket, and bearing against said roller and the spring-actuated stop 31 pivoted in said case above said bracket, substantially as set forth. 13th. The bed-lockers of a sleeping car hinged to the side thereof in a vertical position, and constituting the ends of the sleeping-compartment in which bed-frames are supported, one above the other extending between said lockers, a chair or chairs fixed on the floor of the car near said lockers having a back capable of being turned from an upright to a horizontal position on the seat thereof, combined with a screw-threaded post fixed within a cylinder in the floor of the car, and a hollow post attached to the seat-frames of the chair and screwing onto said post in the car-floor, whereby by turning said frame the latter and the chair parts are lowered below the level of the lower one of said bed-frames, substantially as set forth. 14th. As means for forming a sofa or couch in the car or within the sleeping-compartment formed by the lockers 4, two of the chairs 6 each having pivoted arms 39 and posts 40 thereon swinging respectively on the back and on the seat-frames of said chairs, combined with an upholstered platform 48 placed between said two chairs and resting on the seat-frames thereof, substantially as set forth. 15th. A series of bed-lockers hinged to the side of a car and swinging at right angles thereto, to form the ends of a sleeping-compartment, and a bed-frame or frames supported between said lockers combined with a chair or chairs connected to the floor of the car near said lockers, and capable by means substantially as described of being folded and lowered down without being removed from their positions on the floor to permit the said bed frame to be extended from locker to locker over said chairs, substantially as set forth. 16th. The curtain arrangement herein described, consisting of separate curtains α , $\alpha 1$ for upper berth suspended from bar 15, and curtains Y, Y1 for lower berth suspended from side frame 19, substantially as described. 17th. The combination, with curtains X, X1 having loops $\alpha 1$, $\alpha 1$, of curtains Y, Y1 having hooks γ , γ , for the purpose described.

No. 27,030. Harvesting Machine.

(Moissonneuse.)

William Deering, (assignee of Herman N. Kennedy and Burr A. Kennedy), Chicago, Ill., U.S., 23rd June, 1887; 5 years.

Claim.—1st. In combination, with the tubular sills, the trusses forming the connection from front to rear between said sills made of metal clasped around and pinched onto said tubular sills, and bolts passing through the walls of the tubular sill, and through the embracing truss iron at the bend to force the tubular sill into the bend and increase the grasp of the latter on the sill. 2nd. In combination with the tubular sill, the truss iron clasped around the sill and bolted thereto at the bend, the bolts ϵ passed through both branches of the clasping iron inside the embraced sill. 3rd. In combination with the tubular sills, the trusses connecting them comprising the upper and lower bars, and connecting clasps, and having said clasps bolted to the bars, and made wider than the bars through-out the portion which embraces the sills whereby a more secure attachment to the sills is effected. 4th. In combination with the tubular sills, the trusses connecting them formed of the upper and lower bars and the uniting clasps, the upper bars flanged upward and the upright posts bolted to said flanges. 5th. In combination with the front sill, the truss C2 having its upper and lower bars extended forward beyond the clasp to afford attachment for the pole. 9th. In combination with the front sill, the truss C2 comprising the upper and lower bars, and the clasps connecting them and having said bars

extended forward beyond the clasp, the pole pivot-block bolted between the said extended bars, the shoe secured to the inner end of the sill and provided with the lug *b* in line with the block, and the pole pivoted on the block and having a brace extended to the lug. 7th. In combination with the front and rear sills, the trusses connecting them on the grain side of the wheel, and the gearing frame constituting struts for the trusses. 8th. The truss *C* having the inner segment, and the gearing frame as its struts. 9th. In combination with the front and rear sills, and the two inside trusses connecting the sills, the gearing frame made integral and secured rigidly to both trusses and constituting horizontal bracing between the trusses. 10th. In combination with the two inside trusses, the gearing frame made integral and formed as struts for both said trusses and as bracing between them.

No. 27,031. Table. (Table.)

Jacob Moeller and Ernst Sondermann, Manitowoc, Wis., U.S., 23rd June, 1887; 5 years.

Claim.—1st. The combination, in a table, of a suitable top frame and a series of supporting legs secured to said frame, one of said legs being normally shorter than the remaining legs, and adjustable in length, and the remaining legs being non-adjustable and of uniform length, substantially as described. 2nd. The combination, with the supporting frame lap-jointed at its ends, and the removable fastenings for the legs extending through the lap-joints, of the separable top detachably secured to the supporting frame and the bent clips attached to the top, substantially as set forth.

No. 27,032. Cutting Nippers. (Coupe-net.)

James McFarland, (assignee of George L. Donovan, Meriden, Conn., U.S., 23rd June, 1887; 5 years.

Claim.—1st. The herein-described cutting-nippers consisting of the handles *A*, *B*, pivoted together and each constructed with a jaw, the face of said jaws constructed with a cylindrical longitudinal groove *a* extending nearly across the face of the jaw forming a stop at one end, and with a groove *e* below and parallel with the groove *a*, combined with the cutters *D* constructed with a cylindrical rib *h* corresponding to the groove *a*, and with the lip *g* corresponding to the groove *e* and with the cutting edge *f*, substantially as described. 2nd. The combination of the handles *A*, *B* pivoted together, and each constructed with a jaw *C*, said jaws constructed with a cylindrical longitudinal groove *a*, and with an angular groove *e* below and parallel with the groove *a*, and the cutters *D*, each constructed with a cylindrical rib *h* corresponding to the groove *a*, and with the lip *g* corresponding to the grooves *e* and with the cutting edge *f*, substantially as described.

No. 27,033. Apparatus for and Process of Refining Petroleum. (Appareil et procédé pour épurer le pétrole.)

Herman Frasch, London, Ont., 23rd June, 1887; 5 years.

Claim.—1st. The process of purifying petroleum, by passing fine jets of the petroleum vapour through a liquid hydrocarbon filter, substantially as described. 2nd. A perforated diaphragm suspended in a liquid hydrocarbon filter for the purpose of dividing the petroleum vapour into fine jets, substantially as described. 3rd. A perforated diaphragm, in combination, with a liquid hydrocarbon filter, substantially as and for the purpose specified. 4th. The process of purifying petroleum, by passing fine jets of petroleum vapour through a liquid hydrocarbon filter, for the purpose of retaining the portions of petroleum vapour which have not a boiling point higher than the temperature of the fluid, forming the filter, substantially as described. 5th. In the process of purifying petroleum, the preventing of the excessive accumulation of fluid in the chambers by returning the same to the still, by means of an overflow, substantially as described. 6th. In the process of purifying petroleum, the preventing of the excessive accumulation of fluid in the chambers by returning the same to the still from one chamber to the other in the opposite direction of the outgoing vapour, substantially as described. 7th. In the process of purifying petroleum, the suspension of the diaphragm in the hydrocarbon filter in such a manner as to compel the vapour to pass through the orifices formed in said diaphragm, substantially as described. 8th. In the process of purifying petroleum, the suspension of the diaphragm in the hydrocarbon filter in such a manner that if the small orifices in the diaphragms become closed, an outlet is provided for the vapour, to prevent explosion, substantially as described. 9th. In the process of purifying petroleum, the method of improving the quality of the fluid contained in the last chamber, by allowing a portion of the oil liquified in the condensing pipes to flow back into said chamber, substantially as described. 10th. One or more close chambers *A*, openings *B*, caps *C*, and perforated diaphragms *E* formed with flanges *J*, in combination with one or more tubes *F* and *H*, and liquid hydrocarbon filters *D*, substantially as shown and described and for the purpose specified.

No. 27,034. Stove Draught for Arresting the upward Flight of Sparks and Flames, etc., (Garde-étincelle.)

John Ketchabaw, jr., Bayham, Ont., 24th June, 1887; 5 years.

Claim.—The combination of the reservoir *A*, *A*, the spark and flame arrester *B*, the adjustable collars *C*, *C*, the extended cover *D*, and stove *E*, substantially as and for the purpose hereinbefore set forth.

No. 27,035. Type Writing Machine.

(Graphotype.)

Frederick Myers, Bootle, Eng., 24th June, 1887; 5 years.

Claim.—1st. A type-writing machine having the type-carrying levers arranged radially in a base plate or frame, and so placed that

the operator when writing acts or presses direct upon the type-carrying lever without the intervention of any secondary or connecting lever, substantially as described. 2nd. In a type-writing machine, the combination of a spacing lever pivoted radially with the type-carrying levers, a pivoted lever which actuates the paper-carrying roll, and a longitudinal bar placed parallel with the roll and with which the lever engages. 3rd. In a type-writing machine, the combination with type-levers *C* and wire *D* of the spacing lever *M*, pivoted lever *N*, bar *L* and frame *K*, substantially as described. 4th. The use in a type-writing machine, of a type-carrying lever, of the form and shape of *C*, herein shown and described. 5th. In a type-writing machine, the combination, with the frame *A* and snugs *B*, of the wire *D* and the lever *M* pivoted thereon. 6th. In a type-writing machine, the combination, with the lever *M*, of the arm or lever *E*, the cushion *a* and the spring *e*, substantially as and for the purposes described. 7th. In a type-writing machine, the combination, with the type-carrying lever *M*, of the bracket *V* and ink-carrying roller *T*. 8th. In a type-writing machine, the combination, of the bracket *V*, the spindle *U*, the pivoted spindle *t* and the roller *T* forming an inking device, substantially as described. 9th. In a type-writing machine, the combination, with the paper-carrying roll and bracket *H*, of the spring *I*, the pin *i*, the cam or lever *J* and the thumb-lever *J*1, substantially as described. 10th. In a type-writing machine, the combination, with the paper-carrying roll *G*, of the eccentric clips *Q*, *R*, and the bracket *q*, and the movable bracket *v*, substantially as and for the purposes described. 11th. In a type-writing machine, the combination, with the paper-carrying roll *G*, of the ratchet wheel *K*1, the pawl *k*, the bracket *K*, the rod *L*1 and the lever *N*, substantially as and for the purposes described.

No. 27,036. Gas Burner. (Bec à gaz.)

Joseph W. Calef, North Easton, Mass., U.S., 24th June, 1887; 5 years.

Claim.—The heating of gas before it reaches the gas jet by means of a gas burner cap, or thimble *B* (or anything equivalent) made of material capable of easily conducting heat, and also made to slide tight over a common gas burner *A*, the said cap having a top *c* and slot or hole *D* located at a proper distance from the said common gas burner *A*, so as to provide for a heating gas chamber *E* and a partition *G* *H* at will, all as above described and for the purposes set forth.

No. 27,037. Dynamo-Electric Generator.

(Générateur dynamo-électrique.)

James W. Easton, Reading, Penn., U.S., 24th June, 1887; 5 years.

Claim.—1st. The combination, substantially as hereinbefore set forth, with a dynamo-electric generator, of a subsidiary armature secured to the shaft thereof, additional pole-pieces derived from the main field-magnet of the generator and applied to said subsidiary armature, independent field-magnet coils connected with the subsidiary armature coils and applied to said derived poles, and conductors connecting the circuit of the main with the circuit of the subsidiary armature. 2nd. The combination, with a dynamo-electric generator of a subsidiary armature carried upon the shaft thereof, a field-magnet for the same derived from the field-magnet of the main armature, field-magnet coils applied to the subsidiary field-magnet, and conductors leading from the respective terminals of the subsidiary armature coils to the respective terminals of the main field-magnet coils. 3rd. The combination, substantially as hereinbefore set forth, with a revolving shaft, of two armatures secured thereto, two field-magnets for the same, two sets of magnetizing-coils respectively applied to said field-magnets, two systems of translating devices respectively included in the circuits of said armatures and conductors uniting said circuits with each other. 4th. In a dynamo-electric machine, the combination, with a main field-magnet, of a subsidiary field-magnet derived therefrom, and magnetizing conductors serving to regulate the magnetization of said subsidiary field-magnet. 5th. In a dynamo-electric machine, the combination, with a main magnetizing field-magnet, of a subsidiary field-magnet derived therefrom, magnetizing conductors serving to regulate the magnetization of said subsidiary field-magnet, and a secondary armature in said subsidiary field-magnet.

No. 27,038. Mucilage or Liquid Glue Bottle.

(Bouteille à Colle.)

William H. Rodden, Toronto, Ont., 24th June, 1887; 5 years.

Claim.—1st. A bottle or vessel *A* having a top edge *a*, shaped as specified, in combination with a correspondingly shaped cap *B*, as and for the purpose specified. 2nd. A bottle or vessel *A* having the top edge *a*, shaped as specified, and a projecting ledge *b* surrounding the base of the edge *a*, in combination with a cap *B*, shaped to fit the top edge *a* and rest upon the ledge *b*. 3rd. A bottle *A* having an annular groove *f* formed in the inner surface of its neck, in combination with the grip-bar *g*, substantially as and for the purpose specified. 4th. A brush provided with a handle *C* having a screw *d* formed on it, in combination with a conical shaped helical spring *D*, connected at its top end with the screw *d*, and at its bottom or base end to the cap *B*. 5th. A cap *B* fitted on to the top edge *a* of the bottle or vessel *A*, and having an outwardly flaring collar *e* formed around a hole made in the said cap, in combination with the brush handle *C* connected to the cap *B* by means of a conical shaped helical spring *D*, substantially as and for the purpose specified. 6th. A brush handle *C* having a screw *d* formed on it to receive the upper end of the conical shaped helical spring *D*, which connects it as specified to the cap *B*, in combination with a knob or head *h* formed on the top of the handle *C*, substantially as and for the purpose specified.

No. 27,039. Manufacture of Coated Pills and Capsules. (Fabrication des Pilules et Capsules enduites.)

William L. Howie, Eccles, Eng., 24th June, 1887; 5 years.

Claim.—1st. The hereinbefore described methods of manufactur-

ing a sweet coat covering, envelope, or capsule for medicinal agents by the use of saccharine, substantially as set forth. 2nd. The sweet coat covering, envelope, or capsule for medicinal agents, obtained by the addition of saccharine to the materials in common use, substantially as hereinbefore described.

No. 27,040. Process of Manufacturing Covering Material for Purses, Bags, etc. (*Procédé de Fabrication de Matériel à Couvrir les Bourses, les Sacs, etc.*)

Julian Sale, Toronto, Ont., 24th June, 1887; 5 years.

Claim.—1st. The process of manufacturing a covering for purses, bags etc., by gluing to a thin piece of leather a piece of sheet asbestos and subjecting them top pressure, as described. 2nd. The process of manufacturing a covering for purses, bags etc. by attaching to a thin piece of leather by means of some glutinous material a piece of sheet asbestos and subjecting them to pressure, as described. 3rd. The process of manufacturing a covering for purses, bags etc. by attaching to a piece of cloth by means of some glutinous material a sheet of asbestos and subjecting them to pressure, as described. 4th. A new article of manufacture to be used in the coverings of purses, bags etc., consisting of a thin piece of split leather to which is attached by a glutinous material a sheet of asbestos, the whole being pressed together and allowed to dry substantially as described. 5th. A new article of manufacture to be used in the coverings of purses, bags etc., consisting of a sheet of asbestos on which is glued or pasted a thin piece of leather, the edge of which leather projects beyond the edge of the sheet of asbestos without being shaved or beveled off, and adapted to be pasted or glued onto another piece of material so as to form a junction therewith, substantially as specified. 6th. A new article of manufacture to be used in the coverings of purses, bags etc., consisting of a sheet of asbestos on which is glued or pasted a piece of cloth, the edge of which projects beyond the edge of the sheet of asbestos, and adapted to be glued or pasted onto another piece of material so as to form a junction therewith, substantially as specified.

No. 27,041. Machine for Ornamenting Wood and other Material. (*Machine à Orner le bois et autres Matières.*)

Daniel B. Burdett, Minneapolis, Minn., U.S., 24th June, 1887; 5 years.

Claim.—1st. In a machine for ornamenting wood leather, paper, or other material, the combination, with a fixed bed-plate, of devices for feeding parallel with the bed-plate, and a die-roll above the bed plate angularly adjustable thereto in a vertical plane, substantially as described. 2nd. In a machine for ornamenting wood, leather, paper, or other material, the combination, with a horizontal bed-plate and horizontal feeding devices, of a lower die-roll vertically adjustable and an upper die-roll angularly adjustable in relation to said bed plate in a vertical plane, substantially as described. 3rd. In a machine of the class described provided with a bed plate feed and resistance rollers and suitable driving mechanism, a die-roll adjustable with reference to the bed-plate vertically laterally and angularly in the vertical plane, combination with an independent die-roll laterally and vertically adjustable with reference to said bed-plate, and means for giving pressure to said die-rolls, substantially as set forth, whereby a horizontal surface, and a raised head on the same side at an angle to said horizontal surface or a plane surface with beveled edges may be ornamented at the same time. 4th. In a machine of the class described, the combination, with a horizontal bed-plate, of a horizontal feeding roll projecting above the face of said bed-plate, and a die-roll above said feeding-roll said die-roll being laterally adjustable along the said feed roll and angularly adjustable thereto in a vertical plane, substantially as described. 5th. In a machine of the class described, the combination, with a horizontal bed plate, of horizontal feeding rolls projecting above said bed plate, a lower die-roll vertically adjustable relating to said bed-plate, and upper die-rolls adjustable vertically and angularly in reference to said bed-plate and adjustable transversely thereto, substantially as described. 6th. In a machine of the class described, a die roll head provided with a circular convex upper surface, and with journals at right angles to its die-roll, in combination with vertically reciprocating blocks provided with a lower cross-plate having journal boxes for carrying the journals of said die-roll, and provided with an upper cross bar with concave circular under surface fitting over the corresponding convex circular upper surface of the die head, whereby pressure is applied equally to the die-roll regardless of the angle at which it may be set. 7th. In a machine of the class described, a die-roll head, with circular convex upper surface and provided with journals, as described, a vertically reciprocating block with a lower cross-plate having journal boxes, as described, and provided with an upper cross-bar with circular concave under surface, as described, and having pendant side lips inclosing the die-head, and a set screw in one of said lips for fixing said die head, and die roll in any desired angular position, all in combination substantially as described. 8th. In combination for ornamenting wood, leather, paper and similar material, a bed-plate fixed in a main frame, feed and resistance rollers protruding through openings in said plate, means for imparting motion to said feed-rollers, die-rolls above said bed-plate attached to vertically reciprocating blocks, screws for giving pressure to said die-rolls, an under side die-roll working through transverse opening in said bed plate attached to a vertically adjustable block, a screw for giving pressure to said under side die-roll, a resistance roller above and directly over the under-side-die-roll and attached to a vertically adjustable block, and a screw for giving pressure to said roller, all substantially as described, whereby material may be ornamented on both sides at the same time. 9th. In combination, for the purpose set forth, bed-plate D fixed in the main frame feed rollers E, E' protruding through openings in said bed-plate, vertically laterally and angularly adjustable die-rolls Q attached to block M S, as described, screw M' for giving pressure to die-rolls Q laterally and vertically adjustable die roll J attached to block G H as described screw g' for giving pressure to the same under-side die roll T laterally and

vertically adjustable attached to the block R and screw r' for giving pressure to the same all substantially as described whereby both sides of the material and surfaces of the material at angles to the main body of the material may be ornamented simultaneously and diverse designs may be impressed if desired.

No. 27,042. Treating Hides or Skins.

(*Traitement des Peaux.*)

Joseph Townsend, Glasgow, Scotland, 24th June, 1887; 5 years.

Claim.—1st. The combination of processes for treating hides or skins, wherein the hides or skins are first steeped in a solution or mixture of an aluminate of soda or aluminate of potash, secondly unshaired, thirdly steeped in a solution of boracic acid, and afterwards tanned or treated in an ordinary manner, substantially as hereinbefore described. 2nd. The treating of hides or skins with aluminate or silicate of soda or potash, substantially as hereinbefore described. 3rd. The treating of hides or skins with boracic acid either alone or in combination with a salt of alumina, after having treated them an aluminate or silicate, substantially as hereinbefore described. 4th. The treating of hides or skins that have been treated with lime with boracic acid to remove the excess of lime, substantially as hereinbefore described. 5th. In treating hides or skins, the utilization of the washings containing borate of lime in the tanning process, substantially as and for the purpose hereinbefore described.

No. 27,043. Manufacture of Waterproof and Combined Water and Fireproof Paper. (*Fabrication du Papier Imperméable et Imperméable et Incombustible à la fois.*)

William Roberts, Waltham, Mass., (assignee of Louis Baslet, South Orange, N.J.), U.S., 24th June, 1887; 5 years.

Claim.—1st. The composition of water-proofing ingredients for paper, consisting of mineral oil, stearic acid, tallow fences and caustic alkali, substantially as described. 2nd. The improved article of manufacture, consisting of water proof paper having the water proofing composition incorporated with the paper stock, substantially as described.

No. 27,044. Marking and Stamping Apparatus. (*Appareil à marquer et timbrer.*)

The International Postal Supply Company of New York, Brooklyn, (assignee of George W. Hay and Emil Laass, Syracuse, N. Y., U.S., 24th June, 1887; 5 years.

Claim.—1st. In a stamping or marking machine, a letter supporting bed having stamps or markers arranged thereon reversely in relation to each other, said markers being provided with selecting devices actuated by the nail matter, which in turn actuate the respective stamps, whereby the letter treated will be automatically marked in the proper place without regard to the face presented, substantially as set forth. 2nd. An automatic marking or stamping apparatus comprising a bed for supporting the article to be marked, a marking stamp supported opposite said bed, an actuating barrier or selecting feeler arranged to be encountered by the article passing over said bed, and transmitting motion to the marking stamp, substantially as set forth. 3rd. In combination with a letter supporting bed, a marking stamp movably arranged opposite said bed, and held normally out of the path of the passing letter, and barriers or engaging fingers arranged in the path of the letter to encounter the same, and thereby set in motion, the stamp or marker, substantially as described. 4th. In combination with a letter supporting bed, a carrier for moving the letter over the bed, a stamp or marker, and a mechanical engaging finger to engage the moving letter and transmit motion to the stamp or marker, substantially as described. 5th. A letter feed bed having projections arranged on opposite sides of the path of feed of said bed, said projections forming successively bearing beds and supporting surfaces for the back and front of a letter, as set forth. 6th. In combination with a marker, an electro-motor actuating said marker, a supporting bed provided with a way, a movable barrier or feeler arranged in the way and an electric circuit-closer between the barrier and the electro-motor, as set forth. 7th. The combination, in an automatic letter marking apparatus, of a letter supporting bed having a rectilinear way or path for the moving letters, and two supporting surfaces arranged respectively on said bed at right angles to the letter way, and on opposite sides thereof with automatic stamps or markers of the class herein described, yieldingly sustained against said supporting surfaces and opposite thereto, substantially as and for the purposes set forth. 8th. In combination with a carrier or stamping mechanism, an electro-magnetic motor and a rake or feeler adapted to engage the passing letter upon the carrier to make the circuit and throw the stamp or marker into operation, and a spring for breaking the circuit as soon as the rake is released, substantially as specified. 9th. In combination with a carrier and stamp or marker, and an electro-magnetic motor comprising a magnet and armature, a rake or feeler electrically connected with said motor, means substantially as described, for releasing said rake from the article or letter as soon as the stamp has been applied to the article, and a circuit-breaker arranged to operate as soon as the rake has been released, substantially as set forth. 10th. In combination with a marking stamp, a bed for supporting the article to be marked or stamped, mechanism for forcing the stamp toward the bed, an electric battery, electro-magnets, and an armature for actuating the aforesaid mechanism, electric conductors, and a rake or feeler for operating and closing the circuit automatically with the introduction of the article to be marked or stamped under the marking stamp, as specified. 11th. The combination with a bed for supporting the article to be marked or stamped, and a marker or stamp arranged movably opposite said bed, an electric battery, electro-magnets, mechanism as described for transmitting motion from the armature of the magnets to the marker or stamp, and a movable barrier interposed between the bed and the marker or stamp, and an electric circuit switch actuated by said barrier,

substantially as and for the purpose set forth. 12th. In combination with a bed for supporting the article to be marked or stamped, and a marker or stamp arranged movably opposite said bed, an electric battery electro-magnets, mechanism, substantially as described, for transmitting motion from the armature of the magnets to the marker or stamp mechanism, substantially as described, for moving the article to be marked or stamped on its supporting bed, a movable barrier adapted to engage the article moving on the bed, and an electric circuit switch actuated by the movement of the barrier, substantially as set forth. 13th. In combination with the bed, and a letter conveyor over the same, a stamp or marker facing the conveyor mechanism, substantially as described, for operating the stamp held normally dormant, a yielding barrier over the conveyor adapted to engage the passing letter, a switch arranged to set in motion the stamp actuating mechanism automatically with the movement of the barrier, and means substantially as described, for releasing the barrier from the letter. 14th. In combination with the letter-supporting bed, the stamp or marker, the stamp-actuating mechanism, substantially as described, a rake adapted to engage the passing letter and actuating the switch, and bars bearing on the letter and provided with a cam adapted to engage with the moving rake to throw the rake from the letter, as described. 15th. In the within-described marking or stamping machine, the combination of a rake or feeler adapted to engage the letter and a presser-bar bearing on the letter, as and for the purposes set forth. 16th. In the within-described marking or stamping machine, the combination, with a rake or feeler for engaging with the letter of a presser-bar provided with a cam-surface, and a throw-off mechanism consisting of a rod connected with the rake or feeler, and adapted to ride up said cam-surface, substantially as described. 17th. The throw-off mechanism consisting of the combination of the rake B, with the presser-bar *h*, cam *g*, and cross-bar *f*, substantially as and for the purpose specified. 18th. In the combination with the bed A, stamp C, and electric conductor *i*, *j*, the rake B and rod *b* hinged to the rake and moving in guides *c*, *c*, spring *d*, and metal blocks *l*, *l* connected with the electric conductors, substantially as described.

No. 27,045. Brake Beam for Railway Cars.

(*Sommier de frein de chemin de fer.*)

George H. Poor, St. Louis, Mo., and Harry C. Buboup, Chicago, Ill., (assignees of Phillip Hien, Rock Island, Ill.), U. S., 24th June, 1887; 5 years.

Claim.—1st. The combination, with a car and its brake-levers, of a hollow metallic brake-beam provided with brake-heads, substantially as and for the purposes specified. 2nd. The combination, with a hollow metallic brake-beam, of a truss-rod and strut, substantially as and for the purposes specified. 3rd. The combination, with a hollow metallic brake-beam, of a truss-rod and end-caps, substantially as and for the purposes specified. 4th. The combination, with a hollow brake-beam and truss-rod, of a strut having a clamp end for grasping the brake-beam, substantially as and for the purposes specified. 5th. The combination, with a trussed hollow brake-beam, of a strut having a fork adapted to receive the brake-lever, and a clamp end for grasping the brake-beam, substantially as and for the purposes specified. 6th. The combination, with the brake-beam, of a clamp hanger having an eye for the safety-chain, and tapped for the reception of the guard-fingers, substantially as and for the purposes specified. 7th. The combination, with the brake-beam, of a brake-head having a clamp for grasping the beam, substantially as and for the purposes specified. 8th. The combination, with the hollow brake-beam, of a brake-head having a clamp for securing it to the brake-beam, and a pivoted or rocking brake-shoe, substantially as and for the purposes specified.

No. 27,046. Water-Gauge for Steam Boilers.

(*Indicateur d'eau pour chaudières à vapeur.*)

Loudon Campbell, Alexandria, Va., U.S., 25th June, 1887; 5 years.

Claim.—1st. In a water-gauge for steam boilers, the combination, with the water-gauge glass tube A, of the float D, substantially as described. 2nd. In a water-gauge for steam boilers, the combination, with the water-gauge glass tube A, of the float D provided with collars E, substantially as described. 3rd. The combination, with the water-gauge glass tubes A, of the float D provided with collars E, the D being colored or coated with luminous paint to distinguish it from the glass tube, and water contained therein, substantially as described. 4th. The combination, with the water-gauge glass tube A, of the float D provided with collars E, and the springs F having cork buffers *a* placed in opposite ends of the tube A, substantially as described.

No. 27,047. Roller Mill. (*Moulin à rouleaux.*)

Samuel Duff, Steubenville, Ohio, U.S., 36th June, 1887; 5 years.

Claim.—1st. In combination with three or more rolls, a vertically movable platform supported opposite said rolls, means for elevating and lowering the platform, and cam plates for moving the platform to the bite of the upper rolls, whereby the metal under treatment may be received from the lower rolls and raised to and thrust within the bite of the upper rolls, substantially as specified. 2nd. In a device for rolling metal, an elevator supported in front of a set of rolls, the guide-ways for said elevators having segmental plates K and K₁ secured thereto, so as to swing the platform when it is raised away from the central roll, and then move the same to the bite of the upper rolls, so that the bar will be caught and carried from the platform, substantially as described and for the purpose set forth. 3rd. In combination with a set of rolls, a platform mounted in suitable frame in front of said rolls, said platform having recessed sides, and a transverse bar attached thereto for limiting its swinging movement plate K and K₁ adapted to engage with the recessed edges of the platform, and a lever for elevating the same, the parts being organized, substantially as shown and for the purpose set forth.

No. 27,048. Bell Crank. (*Manivelle de cloche.*)

James Saunders, Petrolia, Ont., 25th June, 1887; 5 years.

Claim.—The bell-crank H having its radial arms *a*, *a*, standing at an angle of about seventy degrees to each other, one of the arms *a* being provided with two or more holes *c*, or their equivalents, for making the necessary attachments thereto, in combination with the brace *b*, and shaft *d*, substantially as and for the purposes specified.

No. 27,049. Cash Tally or Adding Machine.

(*Taille à monnaie ou machine à additionner.*)

John C. Fisk, Carlyle, Ill., U.S., 25th June, 1887; 5 years.

Claim.—1st. In a tally or register, the combination, with the registered disks and wheels in contact therewith, of an operating rod or key, a stop, a lever engaged by the stop, a pawl pivoted to the lever, links connecting the lever and key, a second lever having a curved end, a trip-finger connected with the latter lever, and a cam moving with an adjacent disk to actuate the trip and operate the curved lever for operating the pawl-carrying lever independent of the key, whereby the registering on and carrying to the disk of higher denomination may be done simultaneously should more than one key be used at a time. 2nd. In a tally or register, the combination, with a registering disk and an operating wheel, of a key or rod, a lever, a pawl pivoted thereto for actuating the operating-wheel, a lever having a curved end, and links connecting the key with the pawl-carrying lever toggle-joint fashion and limited in their outward movement by the curved lever, whereby the pawl-carrying lever is moved to advance the operating wheel, substantially as set forth. 3rd. In a tally or register, the combination, of the registering disks, an operating wheel, a tubular extension, a ratchet wheel keyed to the outer end of the extension, a lever mounted on the extension between the ratchet wheel and operating wheel, and having a bifurcated or slotted end, a pawl pivoted to the side of the lever and bearing on the ratchet wheel, the operating key passing through the slotted end, and a stop on the key for engaging the end of the lever, substantially as and for the purposes described. 4th. In a tally or register, the combination, of the registering disks, an operating wheel having a tubular extension, a ratchet wheel keyed to the outer end of the extension, an operating lever pivoted on the extension between the ratchet and operating wheel, and provided with a bifurcated end, a pawl pivoted to the side of the lever and bear on the ratchet, a key passing between the bifurcations of the bifurcated end of the lever, a pair of pivoted links connecting the key with the bifurcated end of the pawl and carrying lever, and a slotted lever having a curved end contacting with the pivoted end of the links and limiting their outward movement, substantially as and for the purposes set forth.

No. 27,050. Pneumatic Gun.

(*Fusil pneumatique.*)

Nat. W. Pratt, Brooklyn, N.Y., U.S., 25th June, 1887; 5 years.

Claim.—1st. In a pneumatic gun system, the combination, with a gun barrel and pressure reservoir, of an interposed firing valve capable of delivering predetermined quantities of compressed gaseous fluid from said reservoir into said barrel, said quantities being variable at will, for the purposes described. 2nd. In a pneumatic gun system, the combination of a gun barrel a firing reservoir, and an interposed firing valve capable of delivering compressed gaseous fluid from said reservoir to the said barrel in quantities, variable at will with a secondary or magazine reservoir the same being charged with gaseous fluid at a higher pressure than that of said firing reservoir and having a controllable communication therewith, for the purposes set forth. 3rd. In a pneumatic gun system, the combination, with a gun barrel capable of both vertical and horizontal movement about a fixed centre without severing its means of reservoir connection of a stationary pressure reservoir, and an interposed firing valve capable of delivering compressed gaseous fluid from said reservoir to said barrel in quantities variable, at will, substantially as described. 4th. In a pneumatic gun system, the combination, with a gun barrel capable of both vertical and horizontal movement about a fixed centre without severing its means of reservoir connection, a stationary firing reservoir and an interposed firing valve capable of delivering compressed gaseous fluid from said reservoir to the said barrel in quantities variable at will, of a secondary or magazine reservoir, the same being charged with gaseous fluid at a higher pressure than that of said firing reservoir, and having a controllable communication therewith, for the purposes set forth. 5th. In a pneumatic gun system, the combination of a gun barrel capable of both vertical and horizontal movement about a fixed centre, a stationary pressure reservoir, a reservoir pipe connection (as a ball and socket joint) capable of yielding to the barrel movements aforesaid, and a firing valve the said firing valve interposed between the said firing valve interposed between the said yielding connection, and the reservoir for the purposes set forth. 6th. In a pneumatic gun system, the combination with an automatic firing valve having an actuating pressure chamber, substantially as shown, of an automatic operating mechanism for controlling the charge or discharge of pressure in said chamber, the said mechanism consisting of an exhaust valve controlling both the induction and eduction of said pressure by means of an automatic operating piston connected to said exhaust valve, the said piston being in turn actuated from an independent pressure application actuated by a controlling means (as a cut off valve) a latch mechanism and an adjustable escape valve, all substantially as described. 7th. In a firing valve operating mechanism, the combination, with an exhaust valve, substantially as shown, for controlling the induction and eduction of pressure to or from the actuating pressure chamber, of an automatic firing valve of an independent automatic pressure system for operating said exhaust valve whereby the latter is caused to exhaust pressure by the act of the operator and to replenish pressure by the automatic action of said independent system such action being regulated by the predetermined adjustment of a variable escape valve substantially as described. 8th. In a pneumatic gun system an automatic firing valve the same being capable of the following distinct periods of action first an instanten-

ous wide open movement second a variable predetermined dwell in its open position and third an instantaneous closing movement the said valve having means substantially as described for causing the said periods of action.

No. 27,051. Churn. (*Baratte.*)

Ellis Wayland, Gest, Ky., U.S., 25 June, 1887; 5 years.

Claim.—1st. In a churn, the combination, with the supporting frame, of the power-levers having longitudinal slots in their lower ends, a bolt passed through said slots to secure the levers to the frame, the dasher-shaft journaled in the supporting frame, and intermediate connections between the dasher shaft and power-levers, the said levers being provided at their upper ends with devices for guiding and causing them to move in horizontal lines, substantially as set forth. 2nd. The combination, with the uprights and the horizontal guide-bars secured upon the upper ends of the same, of the power-levers pivotally secured at their lower ends to the opposite sides of one of the uprights and capable of vertical movement on their pivots friction-rollers journaled upon the inner sides of the power-levers and working between the horizontal guide bars, the dasher-shaft journaled in the guide bars and intermediate connections between the dasher-shaft and the and the power-levers, substantially as set forth. 3rd. A churn having the uprights and the guide-bars secured to the upper ends thereof, the roller F pivoted between the guide-bars, the dasher-shaft journaled in vertical bearings in the guide bars between the uprights and having the windlass thereon, the power-levers pivoted on opposite sides of one of the said uprights by a bolt passing through slots in the lower ends of the levers, and the guide-pins on the upper ends of the said levers to operate between the said guide-bars, combined with the power-strap passing through the upper ends of the handles and around the roller F, and firmly secured at the ends to the windlass to alternately rotate it in opposite directions as the handles are moved back and forth, substantially as described for the purpose set forth. 4th. In a churn, the dasher-shaft having studs on its sides, combined with a dasher having a short shaft attached thereto, and provided at the upper end with the sleeve to fit over the lower end of said dasher-shaft, the upper end of said sleeve having notches to receive the studs on the sides of the said shaft, and the pin to pass through aligned openings in the sleeve and dasher-shaft, substantially as described. 5th. The dasher for a churn comprising a blade N, a blade N₁ at right angles thereto, and a cutter O disposed parallel to the peripheral edge of the blade N₁, the lower end of the cutter being secured in the horizontal blade or bar P fastened to the bottom of the blade N; and extending a short distance beyond it on each side, substantially as described. 6th. The dasher of a churn comprising the blades N, N₁ set at right angles to each other one of which is smaller than the other, and is provided with the cutter O parallel to the peripheral edge thereof and passing through the larger blade the lower ends of the said cutter being secured in the projecting ends of the blade N₁, substantially as and for the purpose hereinbefore set forth.

No. 27,052. Car-Coupling. (*Attelage de Chars.*)

Lavega Self, Piedmont, Mo., U.S., 25th June, 1887; 5 years.

Claim.—1st. The combination, with the draw-bar B provided with the chambered head A, of a spring-actuated follower b provided with the beveled head c, the pin C provided with the shoulder e and lug f, and the covering h adapted to retain the lug f and limit the turning of the pin C, substantially as described. 2nd. The combination, with the chambered head A, of the draw-bar B of the pin C, provided with the T shaped head j and the covering k having the transverse notch k₁, substantially as described. 3rd. The combination with the draw bar B having the chambered head A, provided with the aperture a, of the pin C having the shoulder e and T shaped head j, the rod i, the spring actuated follower b, provided with the beveled head c and the covering h having the segmental recess f₁ and the transverse notch k, substantially as described.

No. 27,053. Traction Bar for Locomotives.

(*Barre d'Atelage pour Locomotives.*)

William W. St. John, New York, N.Y., U.S., 25th June, 1887; 5 years.

Claim.—1st. In a traction device for locomotives, the bar C loosely fitted on stirrups D, D, having hook E and gib I actuated by adjustable bolt G, substantially as and for the purpose hereinbefore set forth. 2nd. In a traction device for locomotives, the suspended hook or link E to receive a traction bar C of a tender, substantially as and for the purpose hereinbefore set forth.

No. 27,054. Piston Packing Ring.

(*Segment de Piston.*)

William W. St. John, New York, N.Y., U.S., 25th June, 1887; 5 years.

Claim.—1st. In a piston packing ring, the ring A provided with bevel A₁, as described and for the purpose hereinbefore set forth. 2nd. A piston having a packing ring provided with a bevel A₁, and the base E wider than height B, as described and for the purpose hereinbefore set forth.

No. 27,055. Combined Blanket and Overcoat. (*Couverture-paletot.*)

Albert H. King, Brooklyn, N.Y., U.S., 25th June, 1887; 5 years.

Claim.—1st. As a new article of manufacture, a blanket provided at the center of one of its sides with a hood, which adapts the blanket to be worn as an overcoat, substantially as specified. 2nd. As a new article of manufacture, a blanket provided at the center of one of its sides with a hood, and with straps and buttons for connecting the ends of the hood and the sides of the blanket, substantially as specified. 3rd. The combination of a blanket a, with a hood consisting of

flaps b, b₁, and connected to blanket a at its center but disconnected at its ends so as to leave the ends of the hood free to be folded over each other, substantially as specified. 4th. The combination of blanket a, with a hood consisting of flaps b, b₁, and connected to blanket a by strip c shorter than such flaps, and with buttons and button holes adapted to close the hood and secure it to the face of the of the blanket, substantially as described. 5th. The combination of blanket a, with a hood connected thereto at its center only, and with the fastening devices g, g₁ adapted to join the sides of the blanket and with fastening devices h, h₁ adapted to join the ends of the hood, substantially as described. 6th. The combination of a blanket a, with a hood secured to the center of its longer side, and having disconnected ends and provided with the following fastening devices e, e₁, f, f₁, g, g₁, h, h₁, h₁₁ and i, substantially as and for the purpose described.

No. 27,056. Apparatus for Indicating the force of a Blow on a Coin, etc.

(*Appareil pour Indiquer la force d'un Coup sur une pièce de Monnaie, etc.*)

Percival Everitt, London, Eng., 27th June, 1887; 5 years.

Claim.—1st. The manufacture and use of the new kind of apparatus for indicating the force of a blow, in which on a coin or the like being placed in the apparatus the force of the blow will be indicated or disclosed and registered. 2nd. The combination, with or application to apparatus, such as is herein described, for indicating the force of a blow, of an arrangement whereby a coin is caused to operate an index or indicator, as and for the purpose hereinbefore described and represented in the accompanying drawings. 3rd. The improved apparatuses for indicating the force of a blow, hereinbefore described and represented respectively in figures 1 to 4 and in figure 5 of the accompanying drawings.

No. 27,057. Method of and apparatus for Polishing Warp Threads. (*Mode de Polissage de la Chaîne et appareil pour cet objet.*)

John Burn, Bradford, Eng., 27th June, 1887; 5 years.

Claim.—1st. The arrangement and combination of the apparatus, whereby warp threads of an indefinite length can be polished by a series of revolving brushes, substantially in the manner shown and described. 2nd. The polishing of warp threads of an indefinite length by revolving brushes mounted on each side of the warp threads, substantially as shown and described.

No. 27,058. Button Hole Sewing Machine.

(*Machine à Coudre les Boutonnieres.*)

William Randel, Troy, N.Y., U.S., 27th June, 1887; 5 years.

Claim.—1st. The combination of a button hole sewing machine, that is a machine organized with not only the necessary stitch forming feed take up and tension mechanism, but also including the necessary cloth clamp and means for giving the same an intermittently vibrating and reciprocating movement, and a plain sewing machine, that is a machine organized with the necessary stitch forming feed take up and tension mechanism with connecting means whereby said plain sewing machine is caused to produce button holes under the control of the button-hole sewing machine, substantially as and for the purpose described. 2nd. The combination of a plain sewing machine, with a button hole sewing machine having its feed bar C and transversely reciprocating plate G extending over both machines, and means as described to connect the driving pulleys of said machines, for the purpose set forth. 3rd. The combination of a plain sewing machine, and a button hole sewing machine having its feed bar and transversely reciprocating plate extending over both machines, with means as described for connecting their driving pulleys and connecting rod uniting the handles of their presser-feet substantially as and for the purpose described. 4th. The combination of a plain sewing machine and a button hole sewing machine having its feed bar and transversely reciprocating plate extending over both machines, with means substantially as described whereby the threads of both machines are simultaneously pulled and slackened under the control of a handle, substantially as set forth. 5th. The combination of a plain sewing machine adjustably secured upon a table or platform, and a button hole sewing machine secured upon said table, each machine having pulleys A₅ and A₆, with a counter shaft d₅, its pulleys d₅ and belts d₇ at each end and connecting rods d₉ parallel with said belts, substantially as and for the purpose described.

No. 27,059. Spray Lamp or Burner for Lighting or Heating. (*Lampe ou bec à jet pour l'éclairage ou le chauffage.*)

James B. Hannay, Loch Long, Scotland, 27th June, 1887; 5 years.

Claim.—1st. In combination, the burner cup 10 made with air admission holes round its lower part, the inner shell 11 extending above the air-admission holes, the air superheating or steam superheating coil 12 arranged inside of the cup 10 and between it and the inner shell 9, substantially as herein set forth. 2nd. In combination, the inner oil nozzle 13 having a cylindrical upper end and a cylindrical base with a conical intervening part, and the outer nozzle 14 having internal cylindrical and conical counter parts of the inner nozzle and grooves in the cylindrical parts for the passage of the steam, the said nozzles being relatively adjustable and the inner nozzle projecting slightly through the orifice of the outer nozzle, substantially as herein set forth. 3rd. In combination with cup bottom 21 of a spray lamp or burner, an oil supply branch pipe 16 with a wick or torch 17 projecting into the cup for the purpose of keeping a constant small flame for relighting the flame, substantially as herein set forth. 4th. The main ascension pipe 20 fitted with regulating valves 22, 24 for the oil air or steam in juxtaposition, and made with a separate internal passage connected to the air or steam supply pipe to

the chamber of the valve 24, and to the branch pipe 28 connected to the superheating coil 12, substantially as herein set forth. 5th. The process or mode of working a spray lamp or burner, in which the oil is supplied under a pressure at least equal to that of the compressed air, such pressure being 15 pounds or more per square inch and in which the air is supplied in quantity sufficient or nearly so for the complete combustion of the oil, substantially as herein set forth. 6th. The oil reservoir 34 placed at a lower level than the burner, and having in it a flexible bag 35 to receive steam or water under pressure, substantially as and for the purpose herein set forth.

No. 27,060. Band Saw Mill.

(*Scierie à scie à lame sans fin.*)

James L. Gage, Chicago, Ill., U.S., 27th June, 1887; 5 years.

Claim.—1st. The combination, with the saws L L₁ and their pulleys, of gage frames having guide pulleys arranged one above and the other below the log to move the auxiliary saw L₁ to and from the line of cut of the saw L, as set forth. 2nd. In a band-saw mill, substantially as described, the divided frame X, screw R and spring K arranged as shown, combined with the saws L, L₁, and with pulleys a, a₁ carried on said frame and arranged to bear upon the auxiliary saw L₁ above and below the log, as set forth. 3rd. The combination, with the band saws and their pulleys, of a two part frame X carrying friction rollers, and a screw R which adjust the said parts to throw the smaller band outward, as set forth. 4th. The combination, with the band saws L, L₁ and their pulleys, of the two part frame X, arranged within the saws, the screw R for adjusting the parts J, J₁ of said frame, the C having the guide pulleys a, a₁ pivoted in the part J and the nut H for adjusting the angle of the arm C at will, as set forth.

No. 27,061. Milk Bucket. (*Jatte à lait.*)

Judson D. Perry, Detroit, Mich., U.S., 27th June, 1887; 5 years.

Claim.—1st. The combination, with the bucket having a side inlet pipe, of the strainer having an outlet pipe or tube removably engaging said inlet pipe and of etc., and of smaller diameter than said pipe, and a spring bail encircling said outlet pipe and connected therewith and with the inlet pipe, substantially as described. 2nd. The combination, with the bucket having inlet pipe, of the strainer provided with tube b formed with flange d, the spring bail pivoted to said tube b and the catch f on the inlet pipe, substantially as and for the purpose specified.

No. 27,062. Atomizer. (*Pulvérisateur d'eau.*)

August P. Lighthill, Boston, Mass., U.S., 27th June, 1887; 5 years.

Claim.—1st. In an atomizer constructed as a single and substantially straight stem, the liquid tube being formed below or beyond the air tube, and the jet orifices being constructed at a point between the ends of the said substantially straight stem, whereby the stem comprising the tubes may be inserted and operated in a small vessel neck, and for the purposes set forth. 2nd. In an atomizer or nebulizer, the combination of a liquid holding vessel or receptacle, and cap or stopper to which the inlet or outlet tubes are attached, with the liquid tube and air tube constructed in a substantially straight line with the jet orifices, which are located at a point between the ends of said substantially straight stem, as set forth. 3rd. In an atomizer, the combination, with the vessel or receptacle, of the liquid and air tube arranged with respect to the vessel to cause the atomized fluid to impinge against the sides thereof, and means, substantially as hereinbefore described, for adjusting the jet orifices of the tubes to bring the same nearer to or remove them farther from the side of the vessel whereby the atomized liquid may be broken into a cloud and the lightness or thinness of such cloud or nebulae may be varied as set forth. 4th. In an atomizer, the combination, with the receptacle and its rotary cover, of the liquid and air tubes constructed as a single and substantially straight stem the liquid tube being formed below or beyond the air tube, and the jet orifices being constructed at a point between the ends of said substantially straight stem, said stem being supported eccentrically in and by said rotary cover, and means substantially as hereinbefore described, whereby the cover may be rotated on the receptacle to bring the atomizing point of the tubes nearer to or remove it farther from the side of the vessel, as set forth.

No. 27,063. Bag-holder and Truck.

(*Accroche-sac et Chariot.*)

John Hogarth, Stratford, Ont., 27th June, 1887; 5 years.

Claim.—1st. The combination of the rims B and C, and the weighted fastening D, substantially as and for the purpose hereinbefore set forth. 2nd. The combination, with the castors E, E, of the frame A, substantially as and for the purpose hereinbefore set forth.

No. 27,064. Clevis for attachment to Plough Beams, etc. (*Volée pour Flèches de Charrues, etc.*)

Edward I. Morey, Whitewater, Wis., U.S., 27th June, 1887; 5 years.

Claim.—1st. An improved clevis consisting of two barrels, a U shaped rod having its arms fitting in the barrels, springs surrounding the said arms, and a bolt for securing the clevis to the object upon which it is used, substantially as herein shown and described. 2nd. In a clevis, the combination, with the barrels B having open rear ends and apertured extensions, of the apertured belt D provided with a head having a semi-circular face g, and the key i having a semi-circular head f, substantially as herein shown and described. 3rd. As an improved article of manufacture, a spring-levis formed of the U shaped rod A having arms a reduced in diameter, the spring barrels B adapted to receive the arms a and inclosed by the barrels B, nuts c received in the ends of the arms a, the bolt D inserted in the prolongations of the ends of the barrels, and provided with a head f having a semi-circular face g and the key i provided with the semi-circular head j, substantially as described.

No. 27,065. Hand Truck. (*Camion à Bras.*)

William A. Cameron, (assignee of Daniel S. Wing), New York, N.Y., U.S., 27th June, 1887; 5 years

Claim.—1st. The combination, with the side bars A, A, cross-bars and wheels L, of standards S, spring-hooks U and bolts P, Q connecting said standards, and spring-hooks to the side bars, substantially as set forth. 2nd. The combination, with the side bars A A cross-bars K, K₁ and forward cross-bars K, K₁ and forward cross-bars K₂ depressed between the side bars of the shoes B, B, secured respectively to the side bars, and each formed with a V shaped projection C comprising reverse branches and the cross-bar d₁ connecting the V shaped projections and depressed between the side bars below the plane of the forward depressed cross-bar K₂, substantially as shown described. 3rd. The combination, with the side bars A, A, of a bracket D having cheek pieces p, p projecting in one direction for securing said bracket to the side bars, and cheek pieces p₁, p₁ projecting in the opposite direction, pivot p₂ supported by the cheek pieces p₁, legs N mounted on the pivots p₂, stops M and bearings I, cast or formed integral with the legs N, the axle J mounted in the bearings I and the wheel L, substantially as set forth.

No. 27,066. Horse Hay Rake.

(*Râteau à Cheval.*)

Albert E. Roberts, Norwalk, Ohio, U.S., 27th June, 1887; 5 years.

Claim.—1st. The means for fastening a rake tooth to its head, consisting of the combination with the rake head, of a spring actuated bolt which engages the rake tooth said bolt to play up and down under the action of the spring through an orifice in the rake head, for the purposes set forth. 2nd. The rake tooth support consisting of a tube D inserted through an opening in the rake head, said tube provided with a slot adapted to engage the rake tooth, and in connection therewith an interior bolt F and spring E, substantially as and for the purpose described. 3rd. The means for fastening a rake tooth, consisting of the combination with the rake tooth of a clamp at its upper end a tubular support passing through the rake head, slotted at its lower end for the reception of the rake tooth, and an interior spring adapted to hold the tooth to its work and permit it to yield in passing over an obstruction, substantially as and for the purposes described. 4th. The tube D supporting a rake tooth, said tube slotted at its lower end to receive the tooth adapted upon its interior for the reception of a spring provided with a shoulder to limit its upward movement through the rake head, and with threaded extremities d and nut d₁ for securing it to the rake head, substantially as and for the purposes described.

No. 27,067. Siphon Faucet. (*Siphon.*)

George W. Arper, Oakland, Cal., U.S., 27th June, 1887; 5 years.

Claim.—1st. The siphon described, composed of pipe B with adjusting brace C, the chamber D, passage E, screw-valve F, the wheel G, passage I, and the discharge chamber H for the purpose of attaching to the corner of an oil can and drawing oil, constructed and operating substantially as and for the purpose set forth. 2nd. The faucet described, composed of the chamber D, the passage E, the screw valve F, the wheel G, the passage I and discharge chamber H, in combination with a siphon formed of pipe bent in any direction to operate as a siphon, constructed and operated substantially as and for the purpose set forth.

No. 27,068. Spring Vehicle. (*Voiture à Ressorts.*)

Cornelia P. Hotchkiss, (assignee of Edmund H. Carpenter), Syracuse, N.Y., U.S., 27th June, 1887; 5 years.

Claim.—1st. The combination, with the axle formed with an abruptly downwardly deflected main portion, or horizontal projections from the end portions over the deflected main portion, and provided with shackle eyes at the free ends, and a cross spring having its end portions below the end portions of the axle, and coiled upward between the aforesaid shackle eyes and adjacent portions of the axle, and terminating with eyes connected directly with the shackle eyes on the axle by bolts passing through said parts, substantially as set forth and shown. 2nd. The combination of the axle formed with an abruptly downwardly deflected main portion, plates clipped onto the top of the end portions of said axle, and projecting horizontally over the deflected portion of the axle, and provided with shackle eyes at their free ends, cross-spring having its end portions below the end portions of the axle and coiled upward between the shackle eyes of the aforesaid plates and adjacent portions of the axle, and connected to said shackle eyes, substantially as described and shown.

No. 27,069. Rubber Boot. (*Botte de caoutchouc.*)

James F. Shaw, James Gould and William R. Brown, Jackson, Mich., U.S., 27th June, 1887; 5 years.

Claim.—1st. A boot having an opening at its instep covered by a flap, having an inwardly projecting portion, the said flap and the edge of the inwardly projecting portion being secured to opposite sides of the opening, substantially as herein shown and described. 2nd. The combination, with a boot having an opening in its instep, of a flap secured to one edge of the said opening, and provided with a pocket having its edge secured to the opposite side of the said slit, and means for holding the flap firmly against the leg of the boot to adjust the opening therein, substantially as herein shown and described. 3rd. The combination with a boot having a slit at its instep, of the flap d having the pocket f, and secured to the boot at the edges of the slit, substantially as herein shown and described. 4th. The combination, with a boot having a slit at its instep, of the flap d provided with the pocket f, and the extension g and the fastening i, j, substantially as herein shown and described.

No. 27,070. Vehicle Wheel. (*Roue de voiture.*)

Milvin L. Smith and Henry I. Patten, Batavia, N. Y., U. S., 27th June, 1887; 5 years.

Claim.—1st. The wooden hub A having the spoke-sockets a and the malleable metal collar B surrounding the hub A, and having apertures b over the spoke-sockets, and provided with projections b' at each end of said apertures, in combination with the spokes C having their inner ends inserted in the apertures b and fitting in the sockets a, end recesses c' and having the projections b' compressed or clamped against the spokes C into the recesses c', substantially as shown and described. 2nd. In combination with the spokes, the herein described spoke, clip E having a socket F formed on the outer side by an annular flange extending from the clip, said socket being large enough to receive the felly body or thickness of the end of the spoke, said clip having an aperture f in the bottom of the socket, which aperture is of sufficient size to permit the passage of the tenon on the end of the spoke, said tenon fitting in the socket d of the felly, and spurs e on the clip to be driven into the felly, all arranged and combined as set forth.

No. 27,071. Remedy for Diseases of the Respiratory Organs. (*Remède pour les maladies des organes respiratoires.*)

John H. Harford and William H. Lee, Toronto, Ont., 27th June, 1887; 5 years.

Claim.—1st. As a new article of manufacture, a ball composed of an antiseptic material or remedial compound, an inner envelope of coarse textile fabric closely enveloping such remedy, and an outer textile covering secured closely around the ball but leaving sufficient of the fabric loose to form a handle for the user, substantially as and for the purpose specified. 2nd. The improved medicinal compound herein described, consisting of slippery elm, blue cohosh, white hellebore, liquorice and hydrastis, carbolized and mixed together in substantially the proportions specified. 3rd. The herein described remedy for diseases of the respiratory organs, consisting of a compound of slippery elm, blue cohosh, white hellebore, liquorice, hydrastis and carbolic acid, enclosed in a textile covering through which the said compound is discharged in a fine cloud of particles by striking upon the exterior.

No. 27,072. Safety Appliance for Railway Cars. (*Appareil de sûreté pour chars de chemin de fer.*)

James A. Jamieson, Frank Caverhill and John B. Caverhill, Montreal, 27th June, 1887; 5 years.

Claim.—1st. The combination, with a car-heater, of a chemical fire-extinguisher suspended to the wall of the car at an angle thereto, and a support from the heater, holding extinguisher normally in a vertical position, all as and for the purposes described. 2nd. The combination, with a car-heater, a chemical fire extinguisher normally inactive, and means for simultaneously mingling the acid and alkali and discharging the contents on to the grate of the heater, all as herein set forth. 3rd. The combination of a car-heater, a chemical fire extinguisher, connection of same with grate of heater, and means for automatically opening communication between fire extinguisher and grate when the cylinder of the former is tipped, all as herein set forth. 4th. In a chemical fire extinguisher, the combination of the cylinder charged with an alkaline solution, a bottle containing the acid, means for holding said bottle in place, and a weighted swinging lever carrying seat for such bottle, all as and for the purposes described.

No. 27,073. Heel Protector. (*Protecteur de talon.*)

Andrew E. Hull, New Britain, Conn., U. S., 27th June, 1887; 15 years.

Claim.—1st. The combination, in a boot-heel, composed of successive lifts of a heel-protector extending through the lower lift and into the second lift, said protector being inserted from the upper side of the lower lift and from the lower side of the second lift, substantially as described and for the purpose specified. 2nd. The combination, in a boot-heel, composed of successive lifts, of a heel-protector extending down into the lower lift and up into the second lift, said protector being hollowed on the upper side thereof, whereby the displaced material of the second lift forms a core or stud for resisting the side thrust on said protector and lower lift, substantially as shown and described. 3rd. The improved heel-protector herein described, it consisting of a hollow plug having a horizontal diaphragm or wall across the lower part thereof, substantially as described and for the purpose specified. 4th. The improved heel-protector herein described, it consisting of a hollow plug having a horizontal diaphragm or wall across the lower part thereof, said wall being above the lower edge, substantially as described and for the purpose specified.

No. 27,074. Button. (*Bouton.*)

Perrin Frères, (assignee of Pierre A. Raymond), Grenoble, France, 27th June, 1887; 5 years.

Claim.—1st. The combination, with an eyelet or socket, substantially as described, of a spring-cap supported by a dome and a clamping eyelet or collar, the parts named being clamped together by a doubly-flanged ring or collar 30, substantially as described. 2nd. The combination, with a socket consisting of a cap 50 formed with a flange 51, a doubly-flanged ring 52, a central tubular eyelet 60, and a concavo-convex ring 70, of a spring-stud consisting of the spring-cap, so formed with flanges 3, a dome 21, a collar or eyelet 22, a clamping collar 30, and a concavo-convex ring 41, substantially as described. 3rd. A fastener or button consisting of a dome surrounded by a spring-cap made from a blank 10, the dome and cap being arranged for attachment to the supporting material, in combination with an eyelet or socket, substantially as described. 4th. The combination, with an eyelet or socket, substantially as described, of a spring-cap

supported by a dome, a clamping eyelet or collar, the parts named being clamped together by a doubly-flanged ring or collar 30, and a double clamping ring arranged to be engaged by the clamping eyelet or collar, substantially as described. 5th. The combination, with a cap 50, of a doubly-flanged ring 52, a ring 53, a sleeve 24 adapted to enter the space between one of the flanges of the ring 52 and the ring 53, said sleeve being formed with a flange 25, substantially as described.

No. 27,075. Ditching and Excavating Machine. (*Machine à fossayer et creuser.*)

Henry Carter, Springfield, Ont., 28th June, 1887; 5 years.

Claim.—1st. The combination of the frame B, B¹, B², B³, B⁴, B⁵, B⁶, B⁷, B⁸, B⁹, B¹⁰, B¹¹, B¹², B¹³, B¹⁴, B¹⁵, B¹⁶, B¹⁷, B¹⁸, B¹⁹, B²⁰, B²¹, B²², B²³, B²⁴, B²⁵, B²⁶, B²⁷, B²⁸, B²⁹, B³⁰, B³¹, B³², B³³, B³⁴, B³⁵, B³⁶, B³⁷, B³⁸, B³⁹, B⁴⁰, B⁴¹, B⁴², B⁴³, B⁴⁴, B⁴⁵, B⁴⁶, B⁴⁷, B⁴⁸, B⁴⁹, B⁵⁰, B⁵¹, B⁵², B⁵³, B⁵⁴, B⁵⁵, B⁵⁶, B⁵⁷, B⁵⁸, B⁵⁹, B⁶⁰, B⁶¹, B⁶², B⁶³, B⁶⁴, B⁶⁵, B⁶⁶, B⁶⁷, B⁶⁸, B⁶⁹, B⁷⁰, B⁷¹, B⁷², B⁷³, B⁷⁴, B⁷⁵, B⁷⁶, B⁷⁷, B⁷⁸, B⁷⁹, B⁸⁰, B⁸¹, B⁸², B⁸³, B⁸⁴, B⁸⁵, B⁸⁶, B⁸⁷, B⁸⁸, B⁸⁹, B⁹⁰, B⁹¹, B⁹², B⁹³, B⁹⁴, B⁹⁵, B⁹⁶, B⁹⁷, B⁹⁸, B⁹⁹, B¹⁰⁰, B¹⁰¹, B¹⁰², B¹⁰³, B¹⁰⁴, B¹⁰⁵, B¹⁰⁶, B¹⁰⁷, B¹⁰⁸, B¹⁰⁹, B¹¹⁰, B¹¹¹, B¹¹², B¹¹³, B¹¹⁴, B¹¹⁵, B¹¹⁶, B¹¹⁷, B¹¹⁸, B¹¹⁹, B¹²⁰, B¹²¹, B¹²², B¹²³, B¹²⁴, B¹²⁵, B¹²⁶, B¹²⁷, B¹²⁸, B¹²⁹, B¹³⁰, B¹³¹, B¹³², B¹³³, B¹³⁴, B¹³⁵, B¹³⁶, B¹³⁷, B¹³⁸, B¹³⁹, B¹⁴⁰, B¹⁴¹, B¹⁴², B¹⁴³, B¹⁴⁴, B¹⁴⁵, B¹⁴⁶, B¹⁴⁷, B¹⁴⁸, B¹⁴⁹, B¹⁵⁰, B¹⁵¹, B¹⁵², B¹⁵³, B¹⁵⁴, B¹⁵⁵, B¹⁵⁶, B¹⁵⁷, B¹⁵⁸, B¹⁵⁹, B¹⁶⁰, B¹⁶¹, B¹⁶², B¹⁶³, B¹⁶⁴, B¹⁶⁵, B¹⁶⁶, B¹⁶⁷, B¹⁶⁸, B¹⁶⁹, B¹⁷⁰, B¹⁷¹, B¹⁷², B¹⁷³, B¹⁷⁴, B¹⁷⁵, B¹⁷⁶, B¹⁷⁷, B¹⁷⁸, B¹⁷⁹, B¹⁸⁰, B¹⁸¹, B¹⁸², B¹⁸³, B¹⁸⁴, B¹⁸⁵, B¹⁸⁶, B¹⁸⁷, B¹⁸⁸, B¹⁸⁹, B¹⁹⁰, B¹⁹¹, B¹⁹², B¹⁹³, B¹⁹⁴, B¹⁹⁵, B¹⁹⁶, B¹⁹⁷, B¹⁹⁸, B¹⁹⁹, B²⁰⁰, B²⁰¹, B²⁰², B²⁰³, B²⁰⁴, B²⁰⁵, B²⁰⁶, B²⁰⁷, B²⁰⁸, B²⁰⁹, B²¹⁰, B²¹¹, B²¹², B²¹³, B²¹⁴, B²¹⁵, B²¹⁶, B²¹⁷, B²¹⁸, B²¹⁹, B²²⁰, B²²¹, B²²², B²²³, B²²⁴, B²²⁵, B²²⁶, B²²⁷, B²²⁸, B²²⁹, B²³⁰, B²³¹, B²³², B²³³, B²³⁴, B²³⁵, B²³⁶, B²³⁷, B²³⁸, B²³⁹, B²⁴⁰, B²⁴¹, B²⁴², B²⁴³, B²⁴⁴, B²⁴⁵, B²⁴⁶, B²⁴⁷, B²⁴⁸, B²⁴⁹, B²⁵⁰, B²⁵¹, B²⁵², B²⁵³, B²⁵⁴, B²⁵⁵, B²⁵⁶, B²⁵⁷, B²⁵⁸, B²⁵⁹, B²⁶⁰, B²⁶¹, B²⁶², B²⁶³, B²⁶⁴, B²⁶⁵, B²⁶⁶, B²⁶⁷, B²⁶⁸, B²⁶⁹, B²⁷⁰, B²⁷¹, B²⁷², B²⁷³, B²⁷⁴, B²⁷⁵, B²⁷⁶, B²⁷⁷, B²⁷⁸, B²⁷⁹, B²⁸⁰, B²⁸¹, B²⁸², B²⁸³, B²⁸⁴, B²⁸⁵, B²⁸⁶, B²⁸⁷, B²⁸⁸, B²⁸⁹, B²⁹⁰, B²⁹¹, B²⁹², B²⁹³, B²⁹⁴, B²⁹⁵, B²⁹⁶, B²⁹⁷, B²⁹⁸, B²⁹⁹, B³⁰⁰, B³⁰¹, B³⁰², B³⁰³, B³⁰⁴, B³⁰⁵, B³⁰⁶, B³⁰⁷, B³⁰⁸, B³⁰⁹, B³¹⁰, B³¹¹, B³¹², B³¹³, B³¹⁴, B³¹⁵, B³¹⁶, B³¹⁷, B³¹⁸, B³¹⁹, B³²⁰, B³²¹, B³²², B³²³, B³²⁴, B³²⁵, B³²⁶, B³²⁷, B³²⁸, B³²⁹, B³³⁰, B³³¹, B³³², B³³³, B³³⁴, B³³⁵, B³³⁶, B³³⁷, B³³⁸, B³³⁹, B³⁴⁰, B³⁴¹, B³⁴², B³⁴³, B³⁴⁴, B³⁴⁵, B³⁴⁶, B³⁴⁷, B³⁴⁸, B³⁴⁹, B³⁵⁰, B³⁵¹, B³⁵², B³⁵³, B³⁵⁴, B³⁵⁵, B³⁵⁶, B³⁵⁷, B³⁵⁸, B³⁵⁹, B³⁶⁰, B³⁶¹, B³⁶², B³⁶³, B³⁶⁴, B³⁶⁵, B³⁶⁶, B³⁶⁷, B³⁶⁸, B³⁶⁹, B³⁷⁰, B³⁷¹, B³⁷², B³⁷³, B³⁷⁴, B³⁷⁵, B³⁷⁶, B³⁷⁷, B³⁷⁸, B³⁷⁹, B³⁸⁰, B³⁸¹, B³⁸², B³⁸³, B³⁸⁴, B³⁸⁵, B³⁸⁶, B³⁸⁷, B³⁸⁸, B³⁸⁹, B³⁹⁰, B³⁹¹, B³⁹², B³⁹³, B³⁹⁴, B³⁹⁵, B³⁹⁶, B³⁹⁷, B³⁹⁸, B³⁹⁹, B⁴⁰⁰, B⁴⁰¹, B⁴⁰², B⁴⁰³, B⁴⁰⁴, B⁴⁰⁵, B⁴⁰⁶, B⁴⁰⁷, B⁴⁰⁸, B⁴⁰⁹, B⁴¹⁰, B⁴¹¹, B⁴¹², B⁴¹³, B⁴¹⁴, B⁴¹⁵, B⁴¹⁶, B⁴¹⁷, B⁴¹⁸, B⁴¹⁹, B⁴²⁰, B⁴²¹, B⁴²², B⁴²³, B⁴²⁴, B⁴²⁵, B⁴²⁶, B⁴²⁷, B⁴²⁸, B⁴²⁹, B⁴³⁰, B⁴³¹, B⁴³², B⁴³³, B⁴³⁴, B⁴³⁵, B⁴³⁶, B⁴³⁷, B⁴³⁸, B⁴³⁹, B⁴⁴⁰, B⁴⁴¹, B⁴⁴², B⁴⁴³, B⁴⁴⁴, B⁴⁴⁵, B⁴⁴⁶, B⁴⁴⁷, B⁴⁴⁸, B⁴⁴⁹, B⁴⁵⁰, B⁴⁵¹, B⁴⁵², B⁴⁵³, B⁴⁵⁴, B⁴⁵⁵, B⁴⁵⁶, B⁴⁵⁷, B⁴⁵⁸, B⁴⁵⁹, B⁴⁶⁰, B⁴⁶¹, B⁴⁶², B⁴⁶³, B⁴⁶⁴, B⁴⁶⁵, B⁴⁶⁶, B⁴⁶⁷, B⁴⁶⁸, B⁴⁶⁹, B⁴⁷⁰, B⁴⁷¹, B⁴⁷², B⁴⁷³, B⁴⁷⁴, B⁴⁷⁵, B⁴⁷⁶, B⁴⁷⁷, B⁴⁷⁸, B⁴⁷⁹, B⁴⁸⁰, B⁴⁸¹, B⁴⁸², B⁴⁸³, B⁴⁸⁴, B⁴⁸⁵, B⁴⁸⁶, B⁴⁸⁷, B⁴⁸⁸, B⁴⁸⁹, B⁴⁹⁰, B⁴⁹¹, B⁴⁹², B⁴⁹³, B⁴⁹⁴, B⁴⁹⁵, B⁴⁹⁶, B⁴⁹⁷, B⁴⁹⁸, B⁴⁹⁹, B⁵⁰⁰, B⁵⁰¹, B⁵⁰², B⁵⁰³, B⁵⁰⁴, B⁵⁰⁵, B⁵⁰⁶, B⁵⁰⁷, B⁵⁰⁸, B⁵⁰⁹, B⁵¹⁰, B⁵¹¹, B⁵¹², B⁵¹³, B⁵¹⁴, B⁵¹⁵, B⁵¹⁶, B⁵¹⁷, B⁵¹⁸, B⁵¹⁹, B⁵²⁰, B⁵²¹, B⁵²², B⁵²³, B⁵²⁴, B⁵²⁵, B⁵²⁶, B⁵²⁷, B⁵²⁸, B⁵²⁹, B⁵³⁰, B⁵³¹, B⁵³², B⁵³³, B⁵³⁴, B⁵³⁵, B⁵³⁶, B⁵³⁷, B⁵³⁸, B⁵³⁹, B⁵⁴⁰, B⁵⁴¹, B⁵⁴², B⁵⁴³, B⁵⁴⁴, B⁵⁴⁵, B⁵⁴⁶, B⁵⁴⁷, B⁵⁴⁸, B⁵⁴⁹, B⁵⁵⁰, B⁵⁵¹, B⁵⁵², B⁵⁵³, B⁵⁵⁴, B⁵⁵⁵, B⁵⁵⁶, B⁵⁵⁷, B⁵⁵⁸, B⁵⁵⁹, B⁵⁶⁰, B⁵⁶¹, B⁵⁶², B⁵⁶³, B⁵⁶⁴, B⁵⁶⁵, B⁵⁶⁶, B⁵⁶⁷, B⁵⁶⁸, B⁵⁶⁹, B⁵⁷⁰, B⁵⁷¹, B⁵⁷², B⁵⁷³, B⁵⁷⁴, B⁵⁷⁵, B⁵⁷⁶, B⁵⁷⁷, B⁵⁷⁸, B⁵⁷⁹, B⁵⁸⁰, B⁵⁸¹, B⁵⁸², B⁵⁸³, B⁵⁸⁴, B⁵⁸⁵, B⁵⁸⁶, B⁵⁸⁷, B⁵⁸⁸, B⁵⁸⁹, B⁵⁹⁰, B⁵⁹¹, B⁵⁹², B⁵⁹³, B⁵⁹⁴, B⁵⁹⁵, B⁵⁹⁶, B⁵⁹⁷, B⁵⁹⁸, B⁵⁹⁹, B⁶⁰⁰, B⁶⁰¹, B⁶⁰², B⁶⁰³, B⁶⁰⁴, B⁶⁰⁵, B⁶⁰⁶, B⁶⁰⁷, B⁶⁰⁸, B⁶⁰⁹, B⁶¹⁰, B⁶¹¹, B⁶¹², B⁶¹³, B⁶¹⁴, B⁶¹⁵, B⁶¹⁶, B⁶¹⁷, B⁶¹⁸, B⁶¹⁹, B⁶²⁰, B⁶²¹, B⁶²², B⁶²³, B⁶²⁴, B⁶²⁵, B⁶²⁶, B⁶²⁷, B⁶²⁸, B⁶²⁹, B⁶³⁰, B⁶³¹, B⁶³², B⁶³³, B⁶³⁴, B⁶³⁵, B⁶³⁶, B⁶³⁷, B⁶³⁸, B⁶³⁹, B⁶⁴⁰, B⁶⁴¹, B⁶⁴², B⁶⁴³, B⁶⁴⁴, B⁶⁴⁵, B⁶⁴⁶, B⁶⁴⁷, B⁶⁴⁸, B⁶⁴⁹, B⁶⁵⁰, B⁶⁵¹, B⁶⁵², B⁶⁵³, B⁶⁵⁴, B⁶⁵⁵, B⁶⁵⁶, B⁶⁵⁷, B⁶⁵⁸, B⁶⁵⁹, B⁶⁶⁰, B⁶⁶¹, B⁶⁶², B⁶⁶³, B⁶⁶⁴, B⁶⁶⁵, B⁶⁶⁶, B⁶⁶⁷, B⁶⁶⁸, B⁶⁶⁹, B⁶⁷⁰, B⁶⁷¹, B⁶⁷², B⁶⁷³, B⁶⁷⁴, B⁶⁷⁵, B⁶⁷⁶, B⁶⁷⁷, B⁶⁷⁸, B⁶⁷⁹, B⁶⁸⁰, B⁶⁸¹, B⁶⁸², B⁶⁸³, B⁶⁸⁴, B⁶⁸⁵, B⁶⁸⁶, B⁶⁸⁷, B⁶⁸⁸, B⁶⁸⁹, B⁶⁹⁰, B⁶⁹¹, B⁶⁹², B⁶⁹³, B⁶⁹⁴, B⁶⁹⁵, B⁶⁹⁶, B⁶⁹⁷, B⁶⁹⁸, B⁶⁹⁹, B⁷⁰⁰, B⁷⁰¹, B⁷⁰², B⁷⁰³, B⁷⁰⁴, B⁷⁰⁵, B⁷⁰⁶, B⁷⁰⁷, B⁷⁰⁸, B⁷⁰⁹, B⁷¹⁰, B⁷¹¹, B⁷¹², B⁷¹³, B⁷¹⁴, B⁷¹⁵, B⁷¹⁶, B⁷¹⁷, B⁷¹⁸, B⁷¹⁹, B⁷²⁰, B⁷²¹, B⁷²², B⁷²³, B⁷²⁴, B⁷²⁵, B⁷²⁶, B⁷²⁷, B⁷²⁸, B⁷²⁹, B⁷³⁰, B⁷³¹, B⁷³², B⁷³³, B⁷³⁴, B⁷³⁵, B⁷³⁶, B⁷³⁷, B⁷³⁸, B⁷³⁹, B⁷⁴⁰, B⁷⁴¹, B⁷⁴², B⁷⁴³, B⁷⁴⁴, B⁷⁴⁵, B⁷⁴⁶, B⁷⁴⁷, B⁷⁴⁸, B⁷⁴⁹, B⁷⁵⁰, B⁷⁵¹, B⁷⁵², B⁷⁵³, B⁷⁵⁴, B⁷⁵⁵, B⁷⁵⁶, B⁷⁵⁷, B⁷⁵⁸, B⁷⁵⁹, B⁷⁶⁰, B⁷⁶¹, B⁷⁶², B⁷⁶³, B⁷⁶⁴, B⁷⁶⁵, B⁷⁶⁶, B⁷⁶⁷, B⁷⁶⁸, B⁷⁶⁹, B⁷⁷⁰, B⁷⁷¹, B⁷⁷², B⁷⁷³, B⁷⁷⁴, B⁷⁷⁵, B⁷⁷⁶, B⁷⁷⁷, B⁷⁷⁸, B⁷⁷⁹, B⁷⁸⁰, B⁷⁸¹, B⁷⁸², B⁷⁸³, B⁷⁸⁴, B⁷⁸⁵, B⁷⁸⁶, B⁷⁸⁷, B⁷⁸⁸, B⁷⁸⁹, B⁷⁹⁰, B⁷⁹¹, B⁷⁹², B⁷⁹³, B⁷⁹⁴, B⁷⁹⁵, B⁷⁹⁶, B⁷⁹⁷, B⁷⁹⁸, B⁷⁹⁹, B⁸⁰⁰, B⁸⁰¹, B⁸⁰², B⁸⁰³, B⁸⁰⁴, B⁸⁰⁵, B⁸⁰⁶, B⁸⁰⁷, B⁸⁰⁸, B⁸⁰⁹, B⁸¹⁰, B⁸¹¹, B⁸¹², B⁸¹³, B⁸¹⁴, B⁸¹⁵, B⁸¹⁶, B⁸¹⁷, B⁸¹⁸, B⁸¹⁹, B⁸²⁰, B⁸²¹, B⁸²², B⁸²³, B⁸²⁴, B⁸²⁵, B⁸²⁶, B⁸²⁷, B⁸²⁸, B⁸²⁹, B⁸³⁰, B⁸³¹, B⁸³², B⁸³³, B⁸³⁴, B⁸³⁵, B⁸³⁶, B⁸³⁷, B⁸³⁸, B⁸³⁹, B⁸⁴⁰, B⁸⁴¹, B⁸⁴², B⁸⁴³, B⁸⁴⁴, B⁸⁴⁵, B⁸⁴⁶, B⁸⁴⁷, B⁸⁴⁸, B⁸⁴⁹, B⁸⁵⁰, B⁸⁵¹, B⁸⁵², B⁸⁵³, B⁸⁵⁴, B⁸⁵⁵, B⁸⁵⁶, B⁸⁵⁷, B⁸⁵⁸, B⁸⁵⁹, B⁸⁶⁰, B⁸⁶¹, B⁸⁶², B⁸⁶³, B⁸⁶⁴, B⁸⁶⁵, B⁸⁶⁶, B⁸⁶⁷, B⁸⁶⁸, B⁸⁶⁹, B⁸⁷⁰, B⁸⁷¹, B⁸⁷², B⁸⁷³, B⁸⁷⁴, B⁸⁷⁵, B⁸⁷⁶, B⁸⁷⁷, B⁸⁷⁸, B⁸⁷⁹, B⁸⁸⁰, B⁸⁸¹, B⁸⁸², B⁸⁸³, B⁸⁸⁴, B⁸⁸⁵, B⁸⁸⁶, B⁸⁸⁷, B⁸⁸⁸, B⁸⁸⁹, B⁸⁹⁰, B⁸⁹¹, B⁸⁹², B⁸⁹³, B⁸⁹⁴, B⁸⁹⁵, B⁸⁹⁶, B⁸⁹⁷, B⁸⁹⁸, B⁸⁹⁹, B⁹⁰⁰, B⁹⁰¹, B⁹⁰², B⁹⁰³, B⁹⁰⁴, B⁹⁰⁵, B⁹⁰⁶, B⁹⁰⁷, B⁹⁰⁸, B⁹⁰⁹, B⁹¹⁰, B⁹¹¹, B⁹¹², B⁹¹³, B⁹¹⁴, B⁹¹⁵, B⁹¹⁶, B⁹¹⁷, B⁹¹⁸, B⁹¹⁹, B⁹²⁰, B⁹²¹, B⁹²², B⁹²³, B⁹²⁴, B⁹²⁵, B⁹²⁶, B⁹²⁷, B⁹²⁸, B⁹²⁹, B⁹³⁰, B⁹³¹, B⁹³², B⁹³³, B⁹³⁴, B⁹³⁵, B⁹³⁶, B⁹³⁷, B⁹³⁸, B⁹³⁹, B⁹⁴⁰, B⁹⁴¹, B⁹⁴², B⁹⁴³, B⁹⁴⁴, B⁹⁴⁵, B⁹⁴⁶, B⁹⁴⁷, B⁹⁴⁸, B⁹⁴⁹, B⁹⁵⁰, B⁹⁵¹, B⁹⁵², B⁹⁵³, B⁹⁵⁴, B⁹⁵⁵, B⁹⁵⁶, B⁹⁵⁷, B⁹⁵⁸, B⁹⁵⁹, B⁹⁶⁰, B⁹⁶¹, B⁹⁶², B⁹⁶³, B⁹⁶⁴, B⁹⁶⁵, B⁹⁶⁶, B⁹⁶⁷, B⁹⁶⁸, B⁹⁶⁹, B⁹⁷⁰, B⁹⁷¹, B⁹⁷², B⁹⁷³, B⁹⁷⁴, B⁹⁷⁵, B⁹⁷⁶, B⁹⁷⁷, B⁹⁷⁸, B⁹⁷⁹, B⁹⁸⁰, B⁹⁸¹, B⁹⁸², B⁹⁸³, B⁹⁸⁴, B⁹⁸⁵, B⁹⁸⁶, B⁹⁸⁷, B⁹⁸⁸, B⁹⁸⁹, B⁹⁹⁰, B⁹⁹¹, B⁹⁹², B⁹⁹³, B⁹⁹⁴, B⁹⁹⁵, B⁹⁹⁶, B⁹⁹⁷, B⁹⁹⁸, B⁹⁹⁹, B¹⁰⁰⁰, B¹⁰⁰¹, B¹⁰⁰², B¹⁰⁰³, B¹⁰⁰⁴, B¹⁰⁰⁵, B^{1006</}

shown and described. 4th. In a tire tightener, the bifurcated push block *l* swivelled upon the screw rod *C*, in combination with a clamp adapted to be secured to a spoke of the wheel, substantially as shown and described. 5th. In combination with the rod *C* having the straight toothed ratchet wheel *D* rigidly secured thereto, the lever *H* journalled on said rod *C*, and provided with the spring hand lever *G* connected by a link *i* to the pawls *h* seated in a lug *t* on the lever *H*, the said parts being constructed and arranged to operate substantially as shown and described.

No. 26,078. Desk. (*Pupitre.*)

Tees and Company, (assignee of David Tees, William Tees and John Calder, Montreal, Que., 28th June, 1887; 5 years.

Claim.—1st. In a roller desk, the sliding lid composed of a lower bar and the slats *K*, constructed, arranged and operating as herein set forth. 2nd. In a desk, the combination, with the interior frame or fitting carrying the pigeon holes *F*, of movable sections or nests *G*, constructed and arranged as herein set forth. 3rd. In a desk, the combination, with the frame *A*, writing table and top, of nests or pigeon-holes or groups of same, *G*, *G*, all as herein set forth and for the purposes described. 4th. In a desk, the combination, with a slide or the writing table, of a memorandum tablet let into the upper surface of either, all as herein set forth.

No. 27,079. Counter to Register Shaft Revolutions. (*Compteur pour enregistrer les révolutions des arbres de couche.*)

Strangways and Co. (assignee of Henry Kitson), Toronto, Ont., 28th June, 1887; 5 years.

Claim.—1st. The combination of the main shaft *B* having an eccentric cam *C*, the pivoted lever *F* and the bracket *A*, which affords bearings for the main shaft, and pivoted lever *F*, as well as the spindle for the graduated disk *E*, the pivoted pawl *G* adapted to engage with teeth formed on the periphery of the graduated disc *E* and the spring *h*, substantially as specified. 2nd. The combination of the main shaft *B*, having an eccentric cam *C*, the pivoted lever *F* and the bracket *A* which affords bearings for the main shaft *B*, pivoted lever *F*, clutch-pawl *H* and stud *e* for graduated disc *E*, the pivoted pawl *D* and the pivoted clutch-pawl *H* adapted to engage with teeth formed on the periphery of the graduated disc *E*, and actuated by the spring *h* and the spring *i*, substantially as described and for the purpose specified. 3rd. The combination of the main shaft *B*, having an eccentric cam *C*, the pivoted lever *F* and the adjusting screw *K* adapted to butt against the lower end of the pivoted lever *F*, the bracket *A* which affords bearings for the main shaft *B*, pivoted lever *F*, adjusting screw *K*, clutch-pawl *H* and the stud *e* of graduated disc *E*, the pivoted pawl *G* and the pivoted clutch-pawl *H* adapted to engage with teeth formed on the periphery of the graduated disc *E*, and actuated by the spring *h* and the spring *i*, substantially as described and for the purpose specified. 4th. The combination of the main shaft *B*, having an eccentric cam *C*, the pivoted lever *F*, the adjusting screw *K*, the pivoted clutch-pawl *H*, graduated disc *E*, the spring *h* and the spring *i*, all of which are afforded bearings by the bracket *A*, the cap *M*, having an index *M* and the pivoted pawl *G* adapted to engage with teeth formed on the periphery of the graduated disc *E*, substantially as described and for the purpose specified.

No. 27,080. Mining Machine.

(*Machine de Mine.*)

The Stine Smith Machine Company (assignee of Samuel B. Stine), Osceola Mills, Mich., U.S., 28th June, 1887; 5 years.

Claim.—1st. In a mining machine, the combination of a cutter-bar carrying a series of knives, and rotating in such direction as to cut with an upward movement, and one or more drive-chains travelling backwardly along the floor of the cut made, substantially as and for the purposes set forth. 2nd. In a mining machine, the combination of a chain shaft, driving chains rotating said shaft, a cutter-bar mounted in front of said chain shaft, and power-driving connections directly between said shaft and cutter bar, substantially as and for the purpose set forth. 3rd. In a mining machine, the combination of the cutter-bar, the shaft mounted back of and parallel therewith, and cog-gearing connecting said shafts, substantially as and for the purposes set forth. 4th. In a mining machine, the combination of a cutter-bar carrying a pinion provided with one or more cutters, and a shaft mounted back of and parallel with the cutter-bar, and carrying a pinion having one or more recesses to receive said cutters, substantially as and for the purpose set forth. 5th. The combination of the pinion *k*, carrying the knife *l* on one side of and adapted to cut a kerf for one half the pinion and the knife *m* on the other side of and adapted to cut a kerf for the other side of the pinion, and the pinion *n* having depressions *n* in the course of said knives, substantially as and for the purposes set forth. 5th. The combination of the pinion *k*, carrying the knives *l*, *m*, the pinion *n* having the depressions *n* in the course of the knives and the half-teeth *t*, substantially as and for the purposes set forth. 7th. In a mining machine cog-gearing, having the peripheral faces of its teeth or cogs downwardly inclined form, the centre toward the edges to provide clearance for the cuttings, substantially as set forth. 8th. In a mining machine cog-gearing, having the faces of the teeth and the bases of the depressions between the teeth downwardly inclined or bevelled from the centre toward the outer edges, substantially as and for the purposes set forth.

No. 27,081. Mining Machine.

(*Machine de Mine.*)

The Stine-Smith Machine Company (assignee of Samuel B. Stine and James V. Smith), Osceola Mills, Mich., U. S., 28th June, 1887; 5 years.

Claim.—1st. In mining machines, the combination of the stationary bed having side portions provided with tracks, and the travelling

ing carriage carrying rotary cutting apparatus, and having longitudinal bars fitting within the side portions of the bed, and provided with rollers mounted in slots in said bars and travelling on said tracks, substantially as and for the purposes set forth. 2nd. In mining machines, the combination of the stationary bed, having the side portions *a*, provided with horizontal plates *a3*, carrying rollers *c*, and the travelling carriage carrying rotary cutting apparatus, and having the bars *d* fitting in said side portions *a*, and provided with side bars *d1* extending under said plates *a3* and rollers *c*, substantially as and for the purposes set forth. 3rd. In mining machines the combination of the stationary bed having the side portions *a* provided with the track *a4* and carrying rollers *c*, the travelling carriage carrying rotary cutting apparatus and having longitudinal bars *d* provided with side bars *d1* extending under said rollers *c*, and the rollers *d2* mounted in said bars *d* and travelling on said tracks *a4*, substantially as and for the purposes set forth. 4th. In mining machines, the combination of the stationary bed having the screw-rack *m*, the carriage travelling thereon and carrying rotary cutting apparatus, the longitudinal shaft *i* mounted in the carriage and having the screw *m* meshing in said screw-rack, the screw-gear *i1* on said shaft *i*, the transverse shaft *h* carrying the screw *h3* meshing with said screw-gear *i1*, the power-shaft and connections between the same and the transverse shaft, substantially as and for the purposes set forth. 5th. In mining machines, the combination of the stationary bed having the screw-rack *m*, the carriage travelling thereon and carrying rotary cutting apparatus, the horizontal shaft mounted in the carriage and having the screw *m* meshing in said screw-rack, the screw gears *i1* and *n3* mounted on said shaft *i*, the transverse shafts *h* and *n*, carrying screws *h3* and *n2* meshing with said screw-gears *i1* and *n3* respectively, clutch apparatus, the power shaft and connections between the same and said transverse shafts, substantially as and for the purposes set forth. 6th. In mining machines, the combination of the stationary bed, the carriage travelling thereon and carrying rotary cutting apparatus, said carriage having the engine shaft *g*, feed-shaft *h*, recede shaft *n*, gearing *g4*, *h1*, *n1*, and means for imparting longitudinal motion to said carriage from said feed-shaft and recede shaft respectively, substantially as and for the purposes set forth. 7th. In mining machines, the combination of the travelling carriage carrying the cutter-tool at its forward end, the driving shaft extending beyond the carriage frame and drive chain connections between the driving-shaft and cutting-tool outside of the carriage frame, substantially as and for the purposes set forth. 8th. In mining machines, the combination with the travelling carriage of the drive-shaft, the cutting-tool having a series of cutters, and the combined driving, cutting and cleaning chains mounted on said shaft and tool within and outside of the carriage-frame, substantially as and for the purposes set forth.

No. 27,082. Mute Bar Damper for Upright Pianos. (*Etouffoir de piano droit.*)

Paul Gmehlin, New York, N.Y., U.S., 28th June, 1887; 5 years.

Claim.—1st. The damper bar *B*, combined with the flexible apron *f*, which is adapted to be carried in the path of the hammers of a piano, substantially as herein shown and described. 2nd. The damper bar *B*, carrying flexible apron *f*, combined with the brackets *g* and with the strings and hammers of a piano, substantially as herein shown and described. 3rd. The damper bar *B*, combined with the moulding *d*, having tapering portion *i*, and with the flexible apron *f*, substantially as herein shown and described. 4th. The damper-bar *B*, provided with the flexible aprons *f* and *f2*, which are set in different planes on said bar, as described.

No. 27,083. Art or Process of Telephony.

(*Système de téléphonie.*)

Harman S. Trueman and Amos R. Bliss, Sackville, N. B., 28th June, 1887; 5 years.

Claim.—1st. In a magneto-telephone receiver or transmitter, the combination of the magnets *D*, *D*, and *E*, *E*, etc., one or more on each side of the diaphragm *F*, the diaphragm *F* and coils of fine wire *C*, *C*, etc., substantially as and for the purpose hereinbefore set forth. 2nd. The improvement in form of vibrating diaphragm, shown in Figs. 6 and 7, and already fully described.

No. 27,084. Electric Belt. (*Ceinture électrique.*)

James H. Woodward, Seward, Neb., U.S., 28th June, 1887; 5 years.

Claim.—1st. In a galvanic battery for local application upon the body, the combination of a lining strip having a series of transverse slits, with a number of cups having their inner end inserted through the slits, and having wires secured to their outer ends hooking over the slits and connected with the adjoining cups, as and for the purpose shown and set forth. 2nd. In a galvanic battery for local application upon the body, the combination of a lining-strip having a series of transverse slits, with a number of zinc cups inserted through the slits and copper coils, with the absorbent into the cups, and having their ends secured to the outer end of the adjoining cup, hooking over the edge of the slits, as and for the purpose shown and set forth. 3rd. In galvanic battery for local application upon the body, the combination of the body strips having flaps at its edges and having elastic fastening straps, a lining strip secured to the body strip and having a series of transverse slits, a number of battery cups or cells inserted into the slits and having the wire from one cup secured to the outer end of the adjoining cup, hooking over the edges of the cups and buttons secured at the edges of the wires of the circuit by means of their shanks, and projecting upon the inner sides of the ends of the body strip, as and for the purpose shown and set forth. 4th. In a galvanic battery for local application upon the body, the combination of the positive wire having its end doubled and bent into cross-shape, having a hook at its lower end pointing downward, and having the ends of the lateral branches bent inward to form retaining hooks, with a wire having metallic buttons at its ends, and bent double to form a loop adapted to be inserted between the retaining hooks and to be hooked upon the lower hook, as and for the purpose shown and set forth.

No. 27,085. Safe Guard for Watches.*(Garde de queue de montre.)*

Samuel C. Watts, New York, N.Y., U.S., 28th June, 1887; 5 years.

Claim.—A safe guard for watches, consisting of an elastic button or disk, having an aperture to permit of its passage over the ring of the watch, and its upper surface provided with recesses extending outwardly on opposite sides of said aperture, the under surface being made to taper toward the watch, whereby it is strengthened and adapted to be rigidly secured upon the watch, substantially as and for the purpose set forth.

No. 27,086. Apparatus for Grading the Soles and Uppers of Shoes and taking the Correct Measure of the Foot. *(Appareil pour assortir les semelles et empeignes des souliers et pour prendre la mesure exacte du pied.)*

Abraham S. Adler, Baltimore, Md., U.S., 28th June, 1887; 5 years.

Claim.—1st. In an apparatus for grading leather, the frame A divided into recessed sections, in combination with the screw B having threads of variable pitch, substantially as herein described. 2nd. The frame A, divided into recessed sections, and screw B having threads of variable pitch, in combination with the sliding blocks and screws D, substantially as and for the purpose set forth. 3rd. In a shoe-maker's measure, the sectional bed plate B and the adjustable plates C₁, in combination with the laterally adjustable blocks E₁, E₁₁, provided with a series of spring-actuated pins *d*, substantially as herein described. 4th. The laterally adjustable metallic blocks E₁, E₁₁, having the spring-actuated pins *d*, and the sectional bed plate B, in combination with the laterally adjustable toe plate having spring-actuated pins, substantially as herein described. 5th. The sectional bed plate B, the metallic blocks E₁, E₁₁, and the adjustable toe plate D₁, in combination with the adjustable heel piece *m*, and the adjustable bar G, provided with spring metal plate *g*, all constructed to operate substantially as and for the purpose described. 6th. The sectional bed plate B, metallic blocks E₁, E₁₁, and adjustable toe plate D₁, in combination with the adjustable heel piece *m*, and the adjustable bar G, provided with spring metal plate *g*, all constructed to operate substantially as and for the purpose described. 7th. The adjustable bar G, provided with the spring metal plate *g*, in combination with the graduated flexible scale strap I for measuring the in-step of the foot, substantially as herein described. 8th. The sectional bed plate B and the adjustable blocks E₁, E₁₁, having the slots *f*, in combination with the flexible measuring strap F engaging said slots and graduated plates C₁, substantially as herein specified. 9th. The sectional bed plate B, heel piece *m* and the flexible measuring strap I₁, in combination with bar G, spring metallic plate *g* and flexible measuring strap I, substantially as herein described.

No. 27,087. Machine for Packing Tubs, Casks and Barrels. *(Machine pour fouler les cuvettes, les tonneaux et les barils.)*

Louis Heyligenstaedt, Grissen, Germany, 28th June, 1887; 5 years.

Claim.—1st. In a tub, cask, or barrel shaking machine, the table *d*, in combination with the swinging board *b*, lever *a* acted upon by the cam *c* on shaft *e*, substantially as set forth. 2nd. In a tub, cask, or barrel shaking machine, the swinging board *b*, in combination with table *d*, lever *a* operated by cam *c* on shaft *e*, substantially as set forth. 3rd. In a tub, cask, or barrel shaking machine, the combination of the table *d*, swinging board *b*, lever *a*, cam *c* on shaft *e* receiving its motion through cog-wheels from driving shaft *g*, substantially as set forth.

No. 27,088. Carriage Shaft-Coupling.*(Armon de limonière de voiture.)*

Joseph Hanson, Wallaston, Ont., 28th June, 1887; 5 years.

Claim.—1st. In a shaft and axle coupling, the ball K in the standard C, and arranged to be projected forward, and held partly in the chamber of the standard, and partly in the eye of the shaft, so as to serve as a pivot thereto, substantially as shown and for the purpose set forth. 2nd. In a shaft and axle coupling the plug D extending through the standard C, and having the thick shank portion *i* for holding the ball K forward into the eye of the shaft, and the smaller shank J serving as a guide to the plug, substantially as described and for the purpose set forth. 3rd. In a shaft and axle coupling, the plug D having the thick shank *i* and smaller shank *j*, the pin *e* passing lug *d* and the spring *f* attached to said pin, substantially in the manner described and shown and for the purpose set forth.

No. 27,089. Combined Saw Set, Gauge and Raker Guide. *(Tourne-à-gauche, jauge et guide-ratissette combinés.)*

Maurice Lalonde, Oscoda, Mich., U.S., 28th June, 1887; 5 years.

Claim.—The compound tool herein described, comprising the stock slotted at A D and B, and having the projections as shown, plates C and P, screws E N, *a* and H, and the screw-driver F, substantially as described.

No. 27,090. Combination Padlock.*(Cadenas à combinaison.)*

Lemuel P. Jenks, Boston, Mass., U.S., 28th June, 1887; 5 years.

Claim.—1st. The bar-guard E, in combination with the lock-bars and thin springs, the lock-case and a hasp, all constructed and arranged substantially as shown and described. 2nd. The bar-guard E, in combination with the lock-bars and thin springs, the lock-case and a hasp, and the bar-guard cover F_x projecting from the hasp, all constructed and arranged substantially as shown and described. 3rd. The herein-described key composed of a bent-up plate of elastic sheet metal, having apertures at the point of bending to admit the insertion and withdrawal of the key-rods respectively, in combination with said key-rods of different lengths, all constructed and arranged substantially as shown and described.

No. 27,091. Heat Deflectors for Registers.*(Défecteur de chaleur pour régistres.)*

Henry P. Klein, Chicago, Ill., U.S., 28th June, 1887; 5 years.

Claim.—1st. A heat deflector for registers, in which is combined a deflecting cover provided with means for sustaining it above the register with enclosed driving and distributing fans, substantially as and for the purposes specified. 2nd. In a heat deflector for registers, the combination of the cover A, with the enclosed rotary fans C, E, substantially as and for the purposes specified. 3rd. In a heat deflector for registers, the combination of the cover A, having openings upon one side for the admission of cold air from the room, with an enclosed turbine and distributing fan mounted upon a common shaft, substantially as and for the purposes set forth. 4th. The combination, with a heat deflectors for registers, of driving and heat distributing fans, with a water reservoir having a suitable opening, whereby the vapours therefrom may be distributed with the currents of hot air, substantially as described.

No. 27,092. Double Fly for Weathercocks and Chimney Vanes. *(Feuille double pour girouettes et les capuchons des cheminées.)*

Ludwig W. Scaufuss, Dresden, Saxony, 28th June, 1887; 5 years.

Claim.—In a weather vane and chimney cap, two pairs of fans, each of a different angle, whereby four inclined surfaces are exposed to the varying force of the wind, for the purpose and substantially as described.

**CERTIFICATES OF THE PAYMENT OF FEES FOR FURTHER TERMS HAVE BEEN ATTACHED TO
THE FOLLOWING PATENTS.**

- | | |
|--|--|
| <p>908. J. A. BEAM, 2nd 5 years of No. 14,893, from the 3rd day of June, 1887. Improvements on Thrashing Machines, 2nd June, 1887.</p> <p>909. J. H. MORAN, 2nd 5 years of No. 14,898, from the 3rd day of June, 1887. Improvements on Vehicle Springs 2nd June, 1887.</p> <p>910. G. T. LEWIS, 2nd 5 years of No. 14,899, from the 3rd day of June, 1887. Improvement on Apparatus for Collecting Waste Fumes from Smelting, etc., 2nd June, 1887.</p> <p>911. J. F. ROSS, 3rd 5 years of No. 8,807, from the 32nd day of May, 1887. Improvements in the Construction of Sheet Metal Packages, 2nd June, 1887.</p> <p>912. J. TACKABERRY, 2nd 5 years of No. 15,487, from the 19th day of September, 1887. Improvements on Animal Powers, 6th June, 1887.</p> <p>913. THE TORONTO REAPER AND MOWER CO., (assignees), 3rd 5 years of No. 7,588, from the 25th day of June, 1887. Improvements on a Machine for Oscillating Joints for Machinery, 9th June, 1887.</p> <p>914. W. N. WHITELEY, 2nd 5 years of No. 14,937, from the 10th day of June, 1887. Improvements on Finger Bars and the mode of Attaching Guard Fingers to the same, 9th June, 1887.</p> <p>915. THE TORONTO REAPER AND MOWER CO., (assignees), 2nd 5 years of No. 14,945, from the 12th day of June, 1887. Improvements on Harvesters and Binders, 9th June, 1887.</p> <p>916. THE TORONTO REAPER AND MOWER CO., (assignees), 2nd 5 years of No. 14,970, from the 15th day of June, 1887. Improvements on Harvesters and Binders, 9th June, 1887.</p> <p>917. THE TORONTO REAPER AND MOWER CO., (assignees), 2nd 5 years of No. 15,012, from the 22nd day of June, 1887. Improvements on Grain Packers for Binding Machines, 9th June, 1887.</p> | <p>918. F. B. RICE, 2nd 5 years of No. 14,973, from the 16th day of June, 1887. Improvements on Valve Gear for engines, 10th June, 1887.</p> <p>919. W. H. PATTEN, S. P. YOUNG and C. D. YOUNG, 3rd 5 years of No. 7,626, from the 16th day of July, 1887. Improvements on a Wheel Rake, 10th June, 1887.</p> <p>920. R. T. MARTIN, 2nd 5 years of No. 16,313, from the 19th day of June, 1887. Improvements on Calculators, 13th June, 1887.</p> <p>921. J. E. BOYLE, 2nd 5 years of No. 15,015, from the 24th day of June, 1887. Improvements on Water Closets, 13th June, 1887.</p> <p>922. G. N. SIDNEY, 2nd 5 years of No. 14,998, from the 20th day of June, 1887. Improvements on Ball Traps, 20th June, 1887.</p> <p>923. P. A. LARIVIERE, 2nd 5 years of No. 15,000, from the 20th day of June, 1887. Improvements in Movable Seat for Carriages, etc., 20th June, 1887.</p> <p>924. THE ROYAL ELECTRIC CO., (assignees), 2nd 5 years of No. 15,183, from the 25th day of July, 1887. Improvements in Electric Lamp Mechanism, 30th June, 1887.</p> <p>925. THE ROYAL ELECTRIC CO., (assignees), 2nd 5 years of No. 15,072, from the 8th day of July, 1887. Improvements on Commutators for Dynamo Electric Machines, 30th June, 1887.</p> <p>926. THE ROYAL ELECTRIC CO., (assignees), 2nd 5 years of No. 15,166, from the 24th day of July, 1887. Improvements in Regulations for Electric Currents, 30th June, 1887.</p> <p>927. THE ROYAL ELECTRIC CO., (assignees), 2nd 5 years of No. 15,206, from the 21st day of July, 1887. Improvements in Dynamo Electric Machines, 30th June, 1887.</p> |
|--|--|

THE
CANADIAN PATENT OFFICE RECORD.

ILLUSTRATIONS.

Vol. XV.

JULY, 1887.

No. 7.

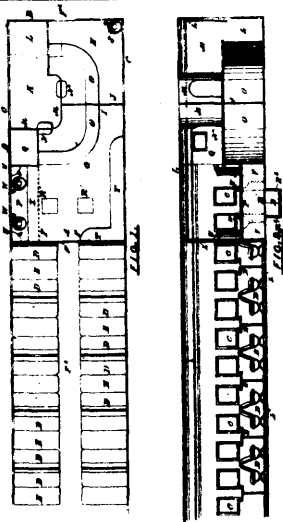

26795 Elliott's Dining Coaches or Cars.

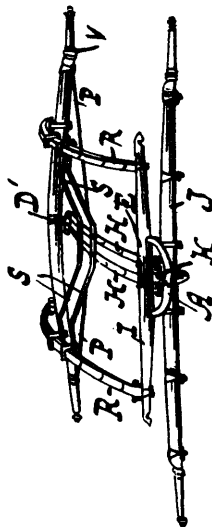

26796 Saladee's Running Gear for Road Waggons.

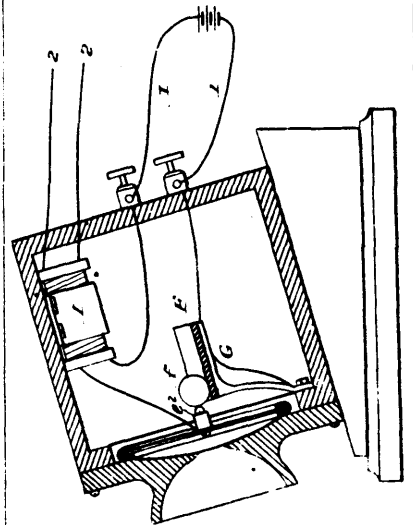

26797 Bonta's Telephony.

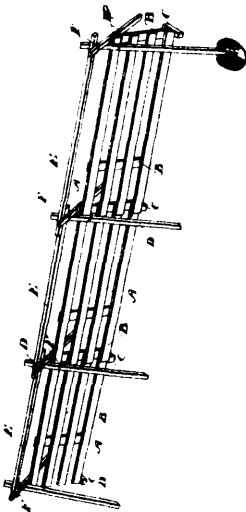

26798 Crabbs' Fence.

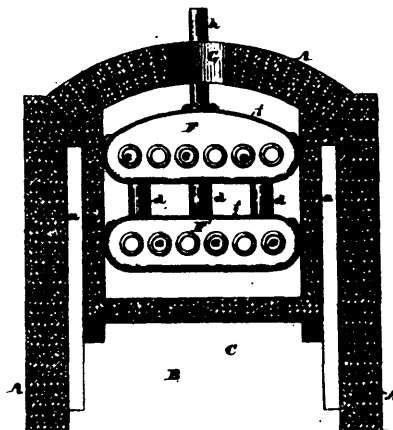

26799 Calhoun's Steam Boiler.

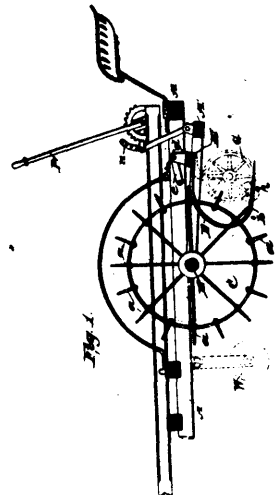

26800 Lubin's Clod Crusher.

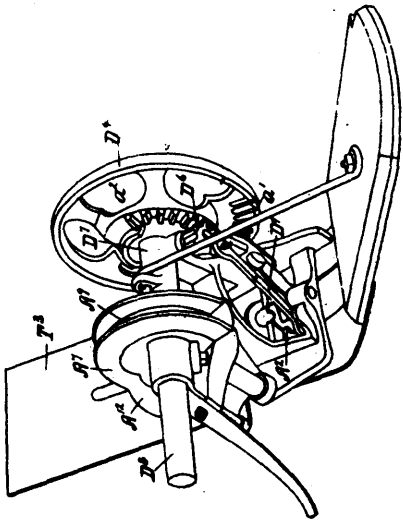

26801 Turnbull's Self-Binding Harvester.

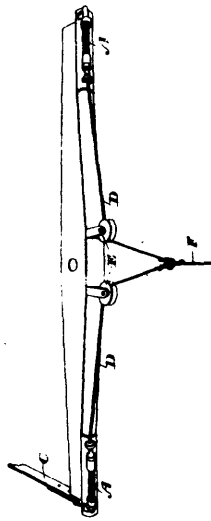

26802 Turnbull's Hitching Gear for Vehicles.

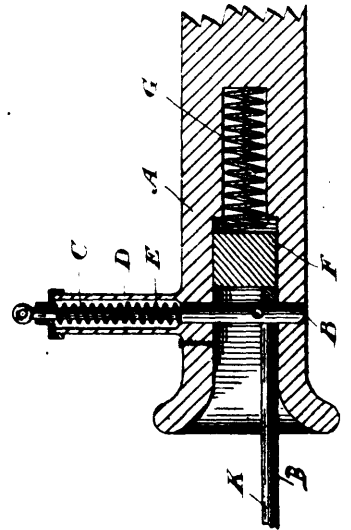

26803 Turnbull's Self-Acting Car Coupler.

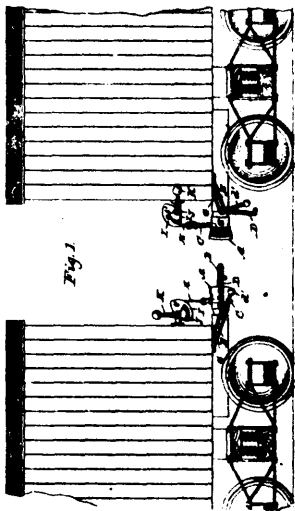

26804 Jackson's Car Coupling.

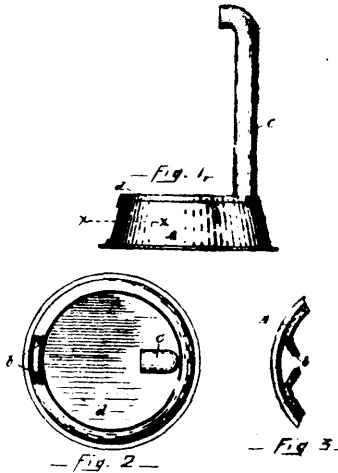

26805 Perrin's Clothes Washer.

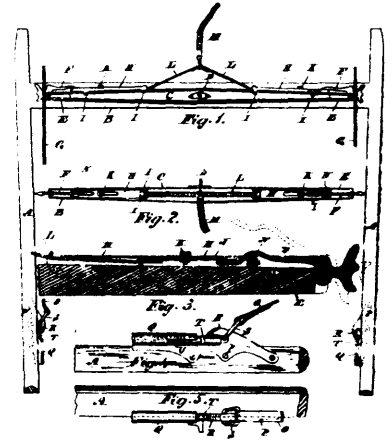

26806 Latashaw's Device for Detaching Horses from Vehicles.

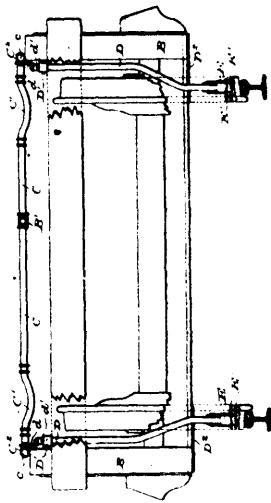

26807 Wescott & Bristol's Car Brake.

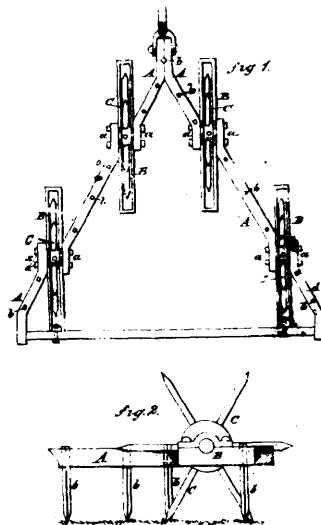

26808 Rothchild's Harrow and Pulverizer.

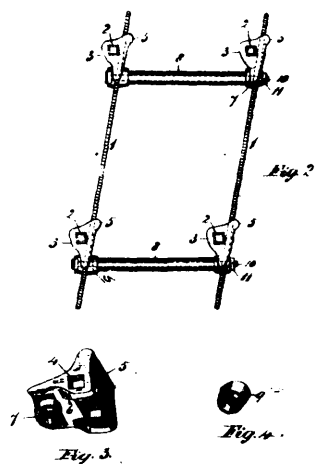

26809 Evans' Harrow.

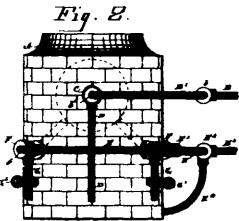
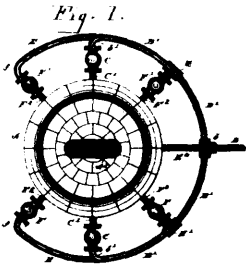

26810 Benninghoff & Jewell's Heat Producing Apparatus.

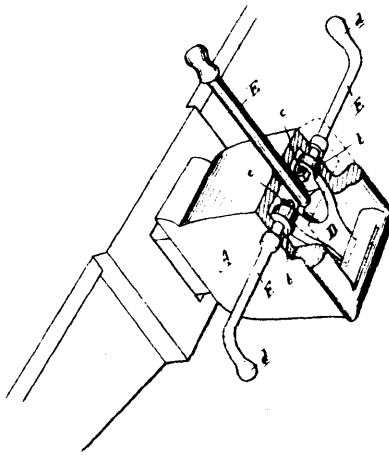

26811 Wilson's Car Coupler.

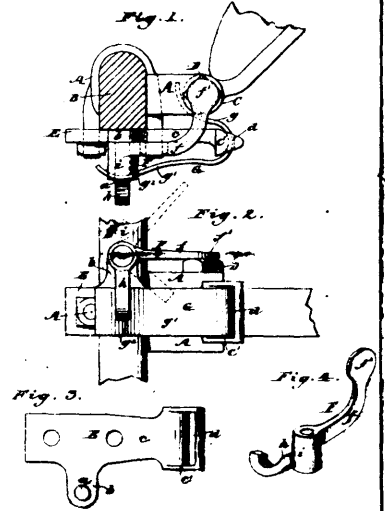

26812 Roman's Anti-Rattler and Thill Bolt Holder.

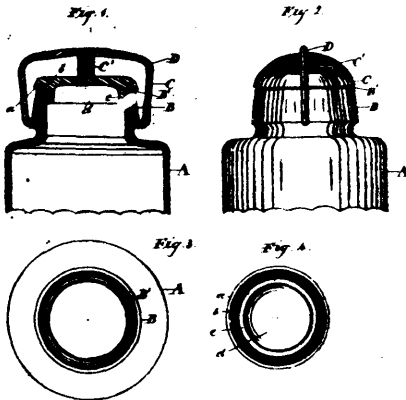

26813 Bothwell's Fruit Jar.

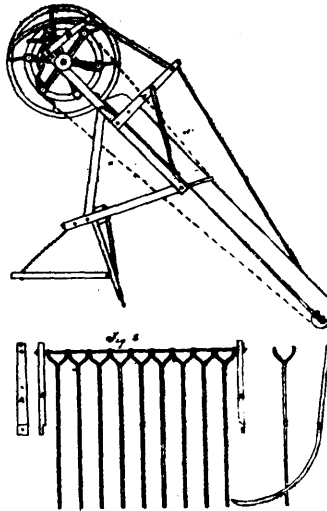

26814 Anderson's Grain Loader.

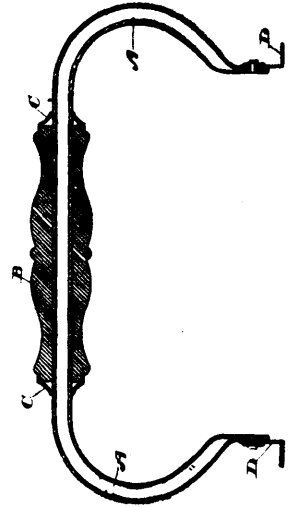

26815 Booth's Kettle Handle.

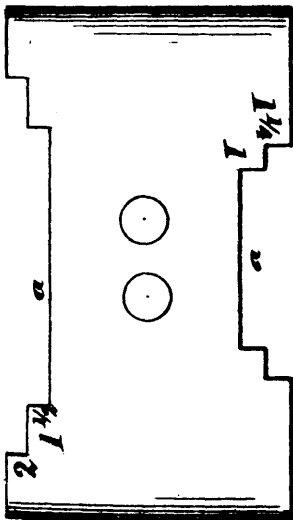

26816 Clifford's Lumber Rule.

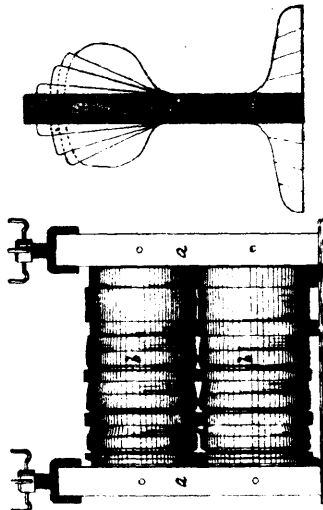

26817 Miller's Method of Converting Used Steel Rails into Nail Plate.



26818 Cheesworth's Screen.

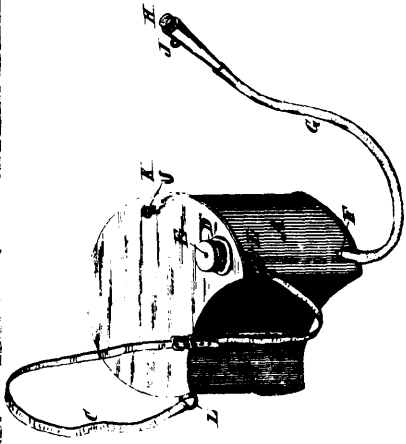

26819 Manhard's Sprinkler for Paris Green.

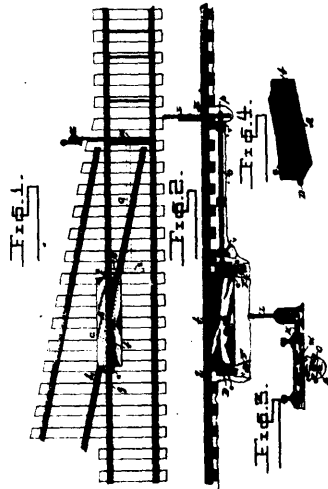

26820 Hoyt's Railway Track Crossing.

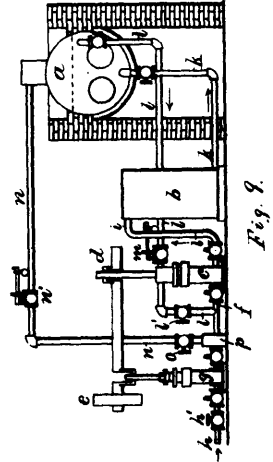

26821 Hyatt's Water Filter for Steam Boilers.

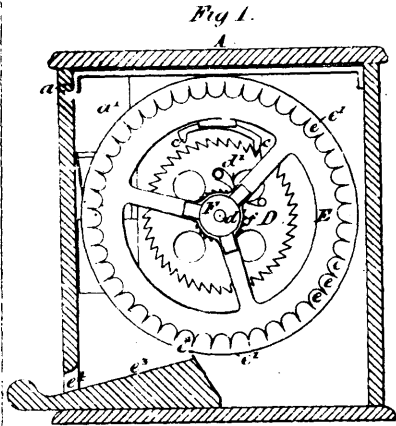

26822 Russell's Automatic Goods Selling Apparatus.

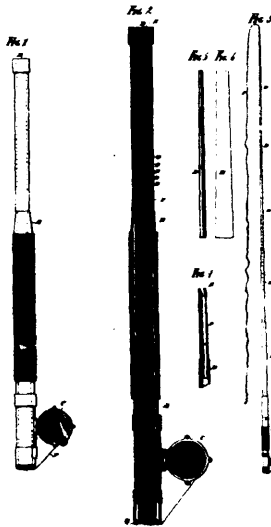

26823 Horton's Fishing Rod.

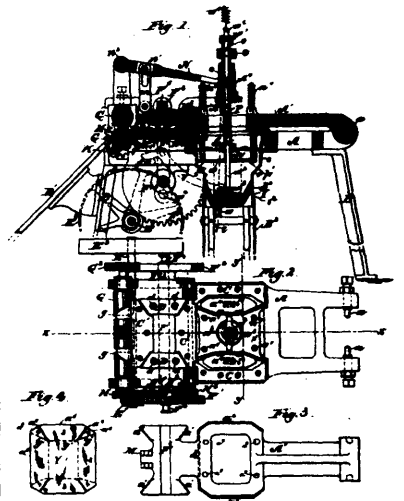

26824 Earle's Butter Dish Machine.



26825 Spinner's Process for Conveying Remedies to the Seat of Disease.

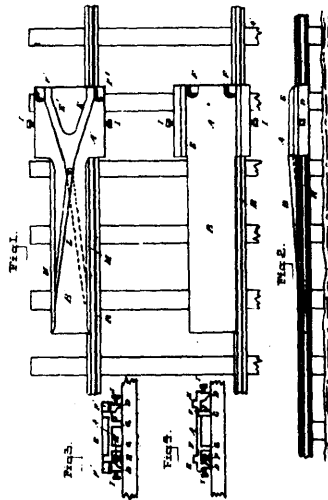

26826 Durieu's Portable Switch Table and Car Replacer.

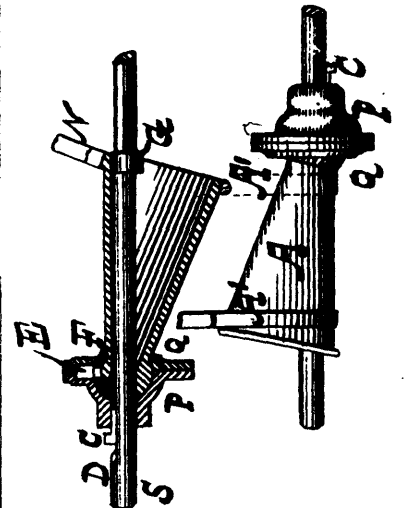

26827 Beaumont's Apparatus for varying the Velocities of Rotating Mechanism.

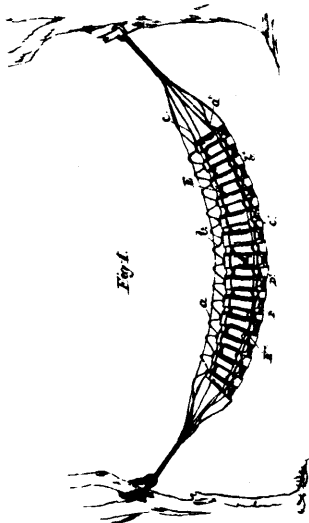

26828 Atkins & Ritchie's Camp Hammock and Table.

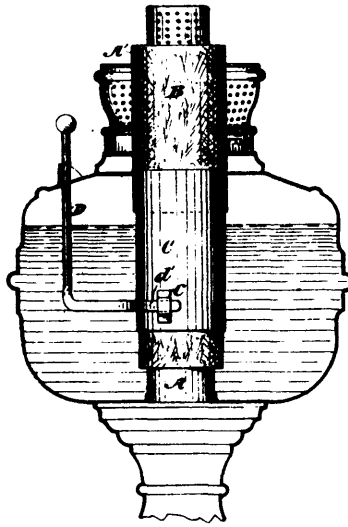

26829 Hull's Wick Raising Mechanism for Lamps.

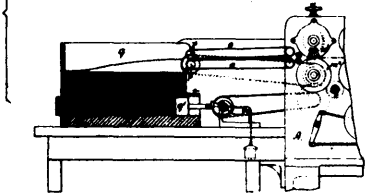
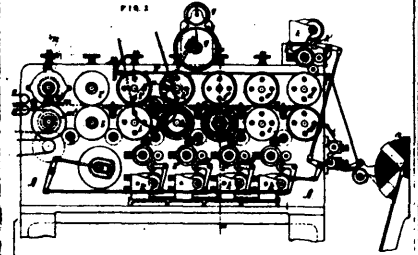

26830 Black's Numbering, Printing, Cutting and Collecting Tickets, Cheques, Labels, etc.

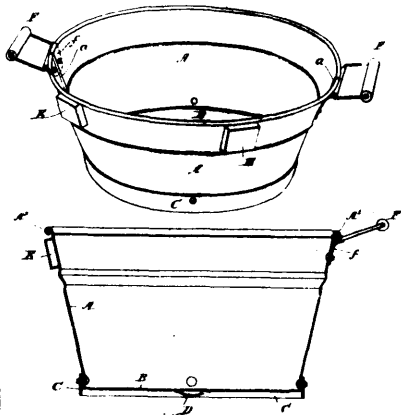

26831 Blouin's Tub.

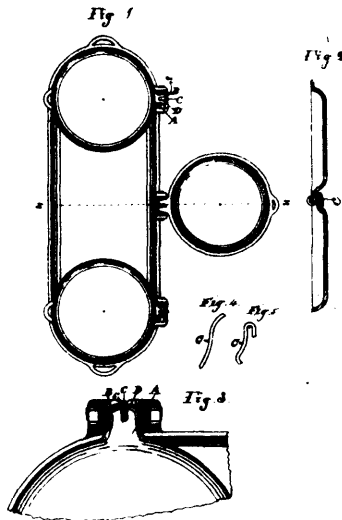

26832 Van Etten's Hinge for Cake Griddles.

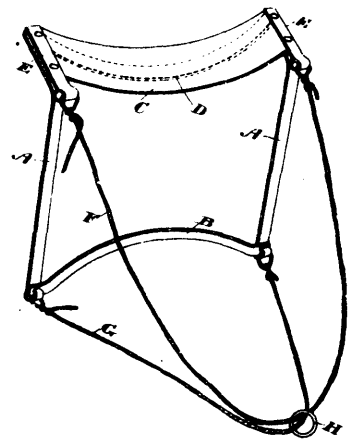

26833 Smith's Head Rest.

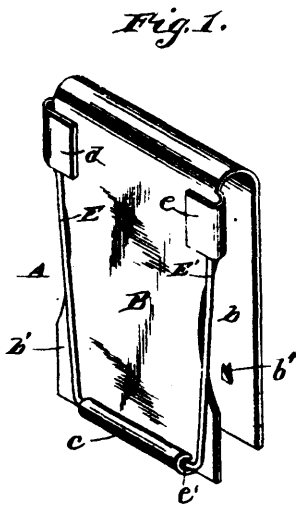

26834 Sink's Garment Supporter.

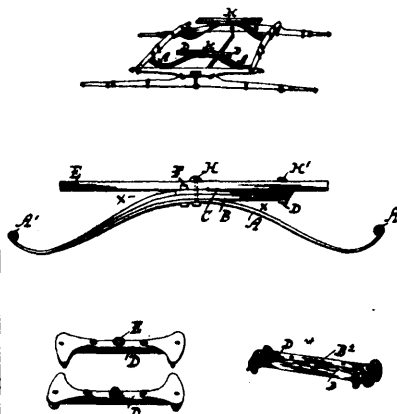

26835 Saladeo's Running Gear of Road Waggon.

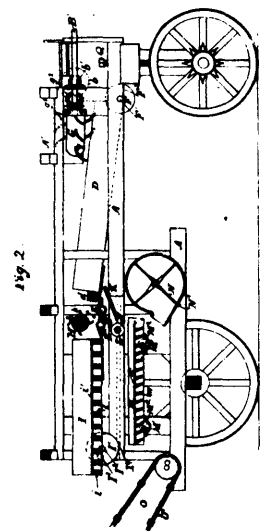

26836 Eves' Thrashing Machine.

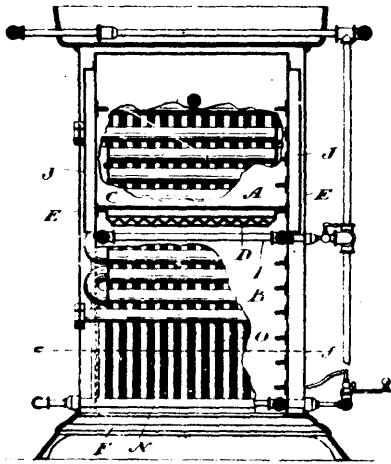

26837 Laxton's Gas Stove.

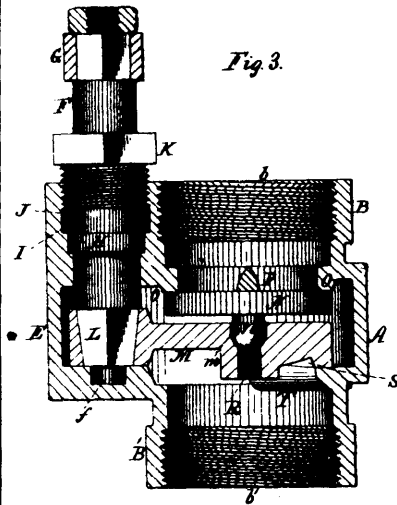

26838 Lunkenheimer's Straight-Way Valve.

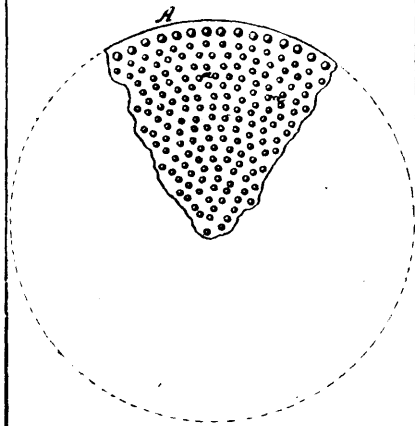

26839 Krans' Coin Pad for Use on Counters, Glass Cases, etc.

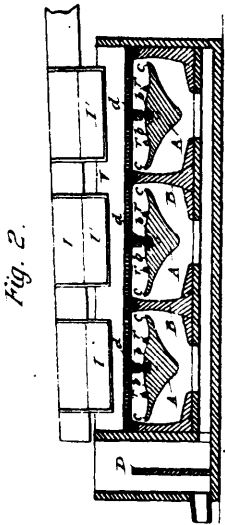

26840 Russell & Cragin's Paper Pulp Screen.

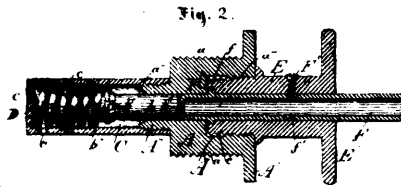

26841 Linindolls' Combined Plug and Cock for Barrels, etc.

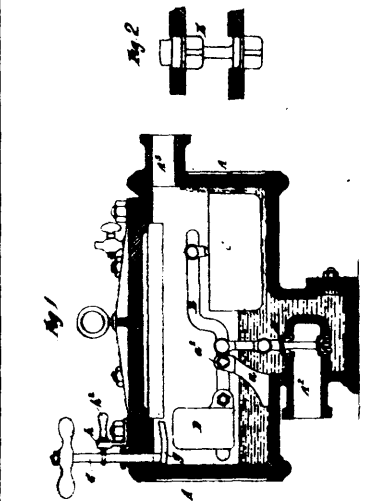
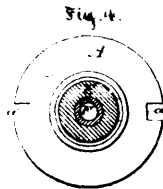

26842 McDougall & Sugden's Steam Trap, etc.

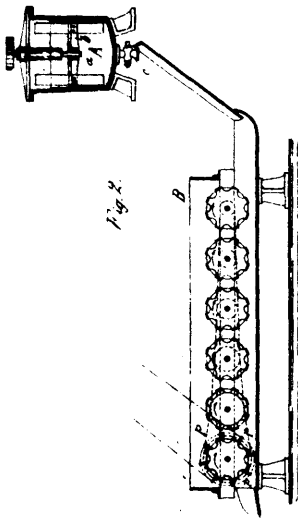

26843 Weber & Fischer's Extracting Gold and other Precious Metals from their Ores, etc.

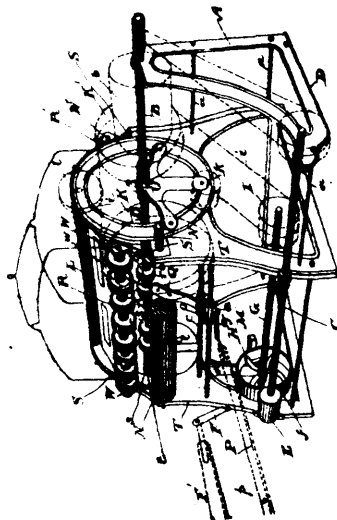

26844 Payette's Edging Machine.

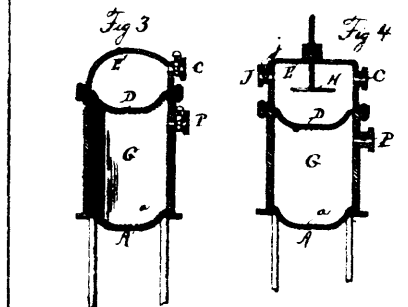
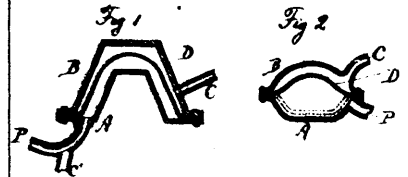

26845 Carmichael's Process of Moulding Articles of Fibrous Ware.

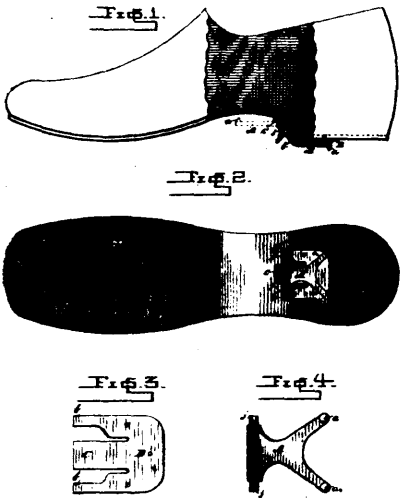

26846 Skinner's Ice Creeper.

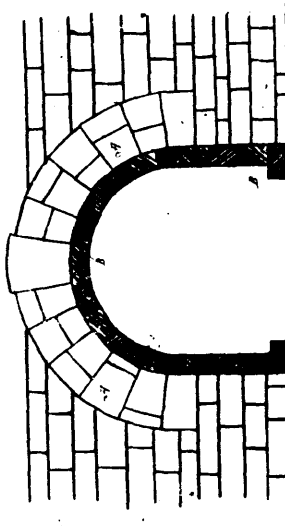

26847 Gilman's Construction of Tunnels, Subways or Arches.

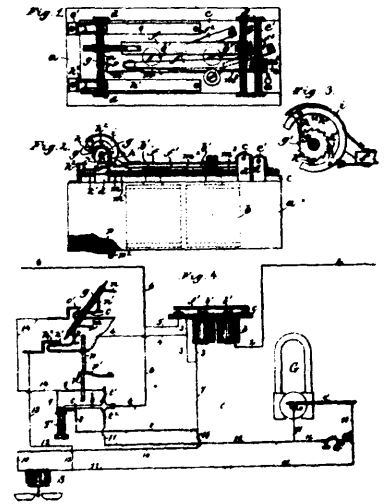

26848 Dudley's Electric Signalling Apparatus.

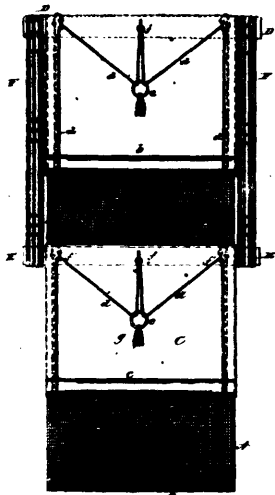

26849 Darland's Window Curtain and Mosquito Bar Combined.

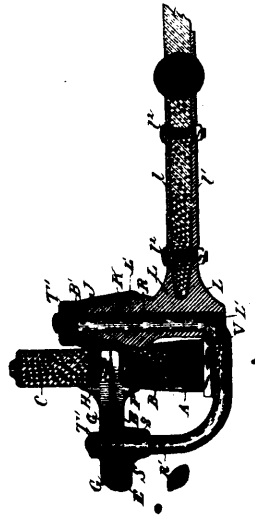

26850 Grier's Fifth Wheel.

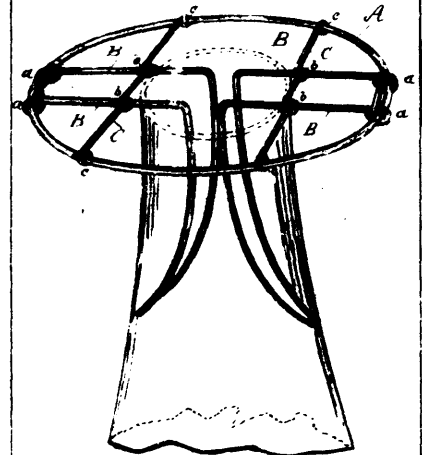

26851 Long's Lamp Attachment.

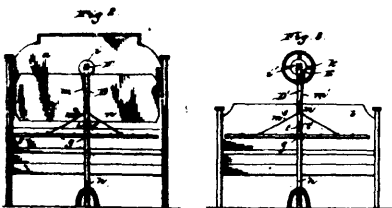
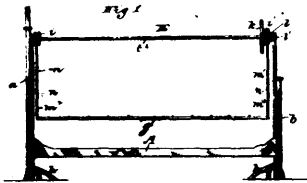

26852 Drake's Hospital Bedstead Attachment.

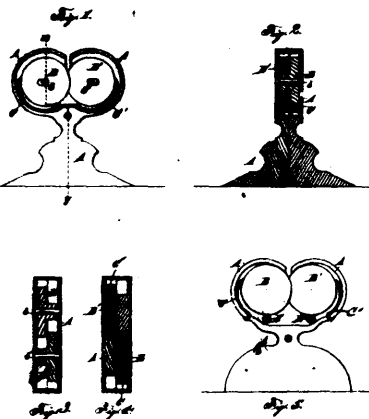

26853 Reinhold's Knife Sharpener.

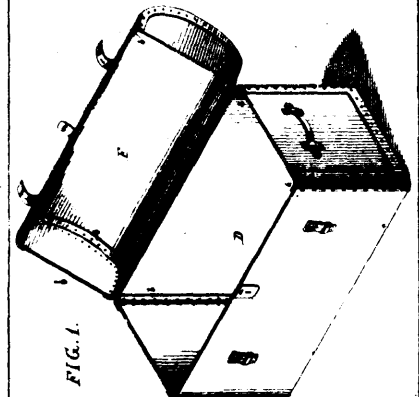

26854 Morrow's Manufacture of Trunks, etc. from Chemically Treated Fibres.

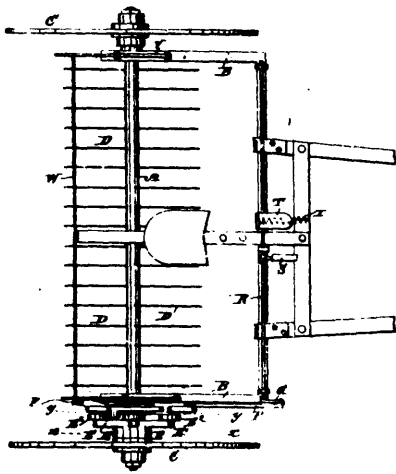

26855 Schauer's Horse Hay Rake.

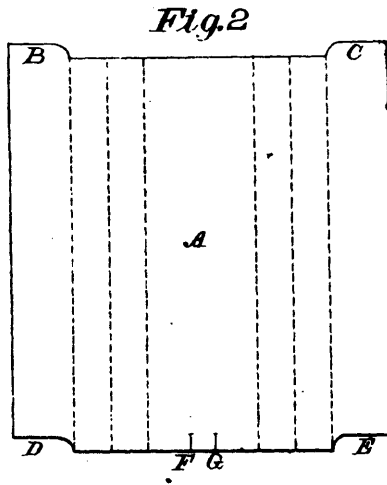

26856 Honiss' Paper Bag.

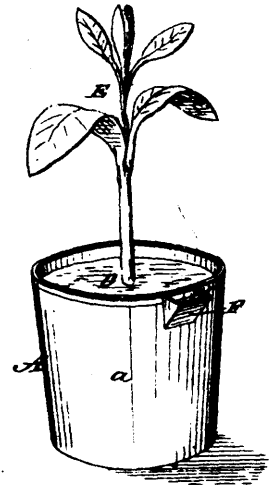

26857 Hunter's Flower Pot.

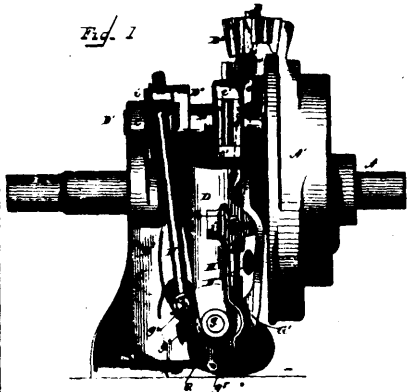

26858 Seiberling's Grain Binder.

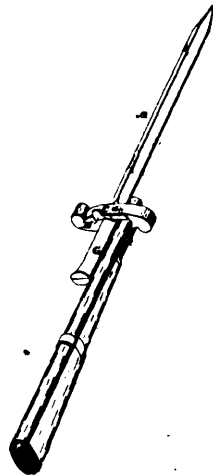

26859 Schillo's Bayonet.

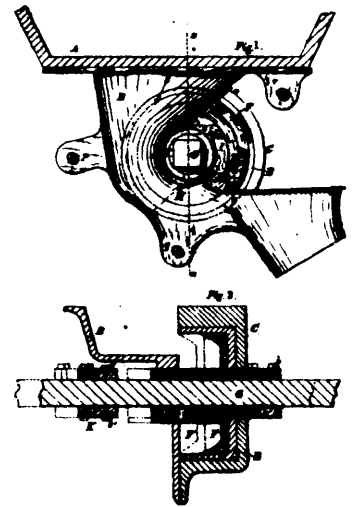

26860 Corser's Seed Drill.

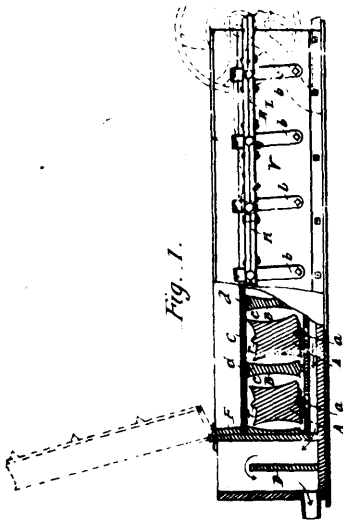

26861 Bussel & Craigin's Paper Pulp Screen.

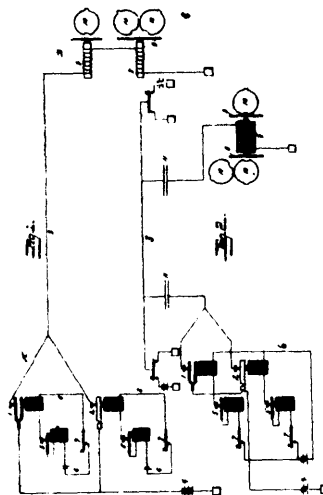

26862 Barnard's Acoustic or Tone Telegraph

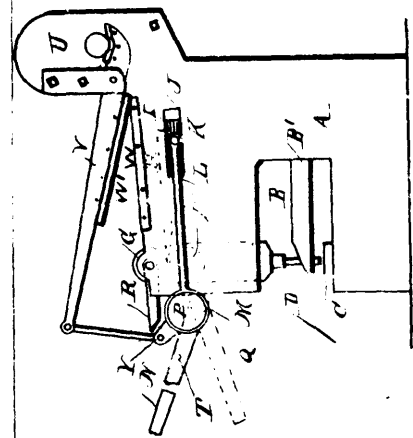

26863 McDonald's Punching and Shearing machine.



26864 Gillock's Car Coupling.

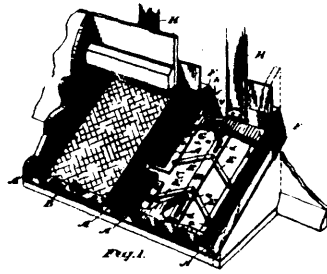

26865 Foley's Organ Pedal.

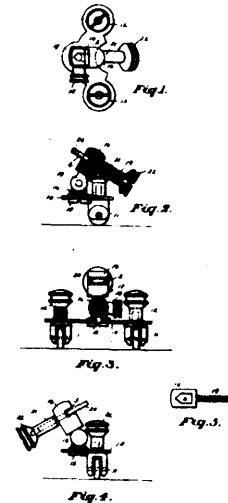

26866 Foley's Sharpening Attachment for Tools.

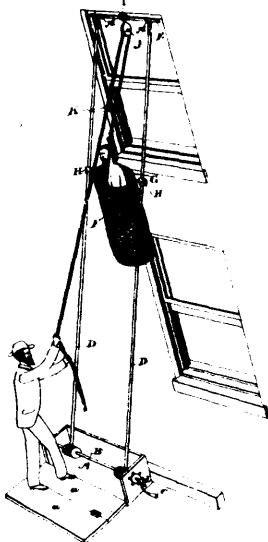

26867 O'Neil's Fire Escape.

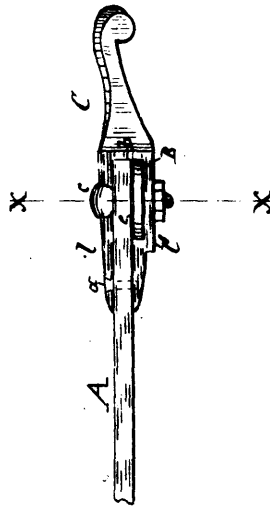

26868 Pell's Spring Coupling for Vehicles.

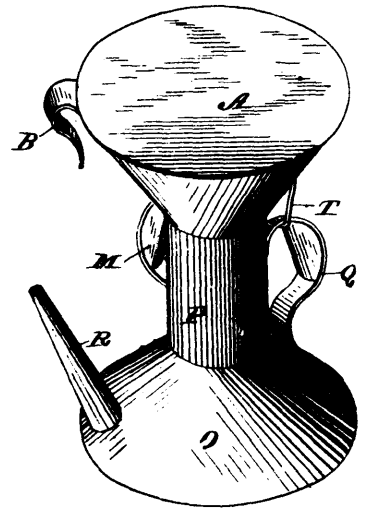

26869 Ribbeck's Drip Coffee Pot.

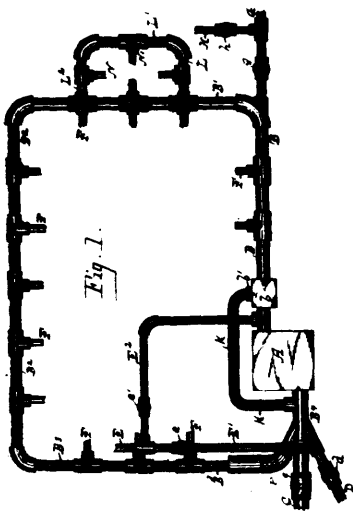

26870 Benninghoff's Air and Gas Mixing Process and Supplying Apparatus.

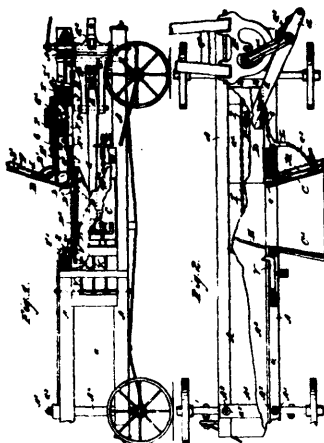

26871 Ertel's Baling Press.

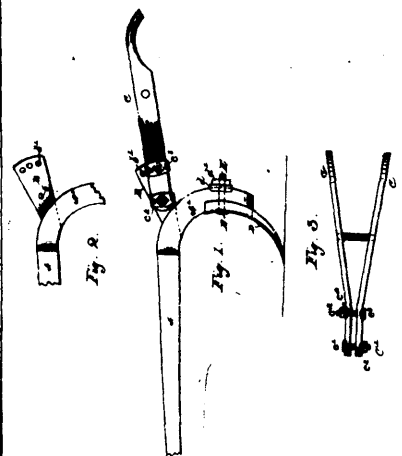

26872 Montcalm's Adjustable Plough Handles.

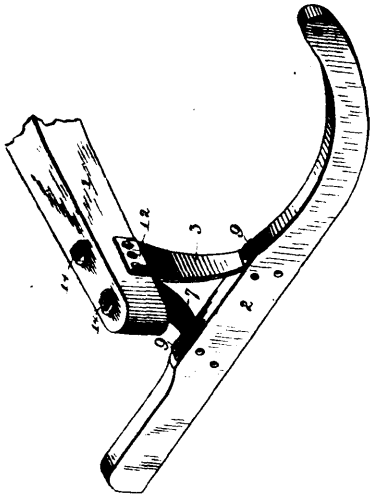

26873 Mandt's Bob Sled.

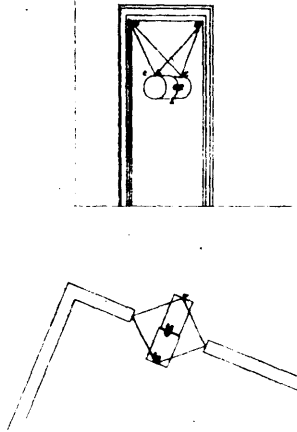

26874 Keirstead's Churn.

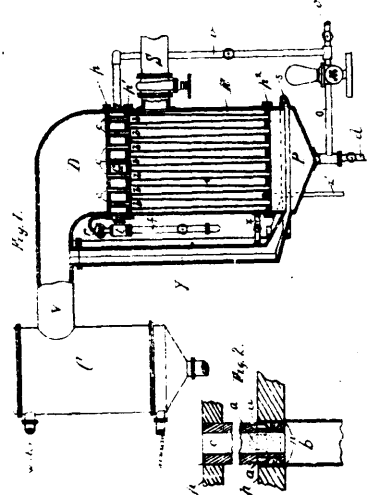

26875 Lillie's Process of Evaporating Sugar Solutions and other Liquids and Apparatus for Carrying on the Same.

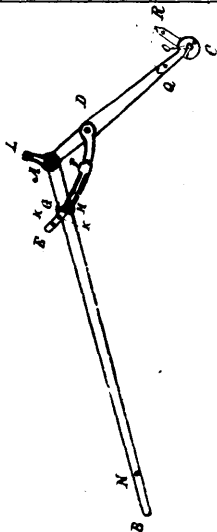

26876 Quinn & McLellan's Steel Horse Check Reins and Nose Extender.



26878 Campbell's Electric Conductor



26879 Teague's Dental Disk.

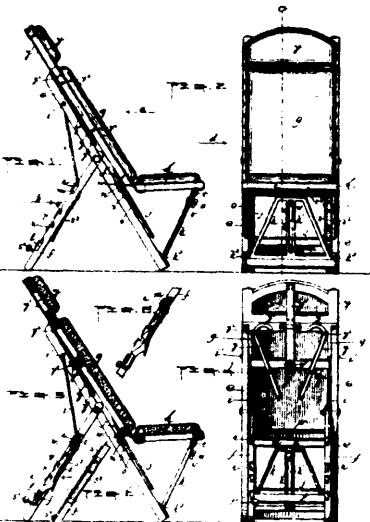

26880 Marston's Surgeon's Combined Chair and Table.

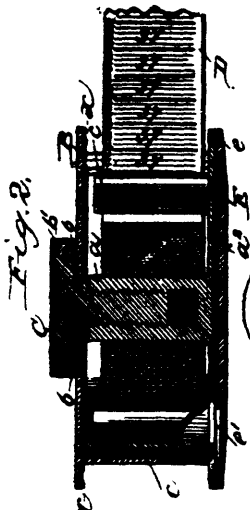

26881 Harper's Ticket Case.

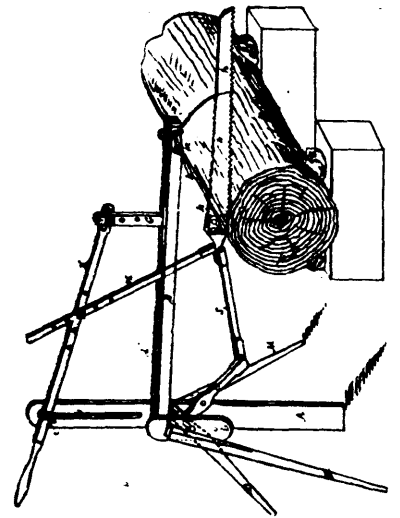

26882 Wright's Drag Saw Machine.

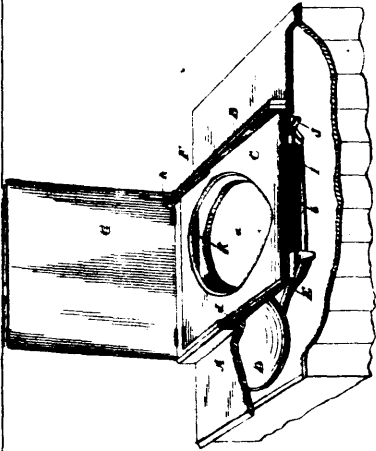

26883 Kelly & Ball's Privy Seat.

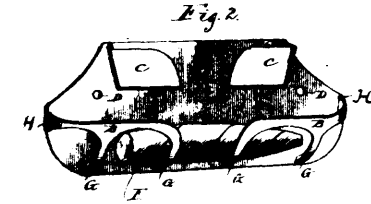
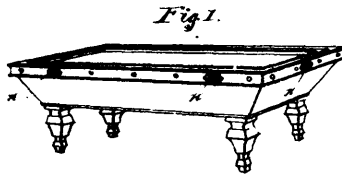

26884 Hough's Skeleton Cigar Holder.

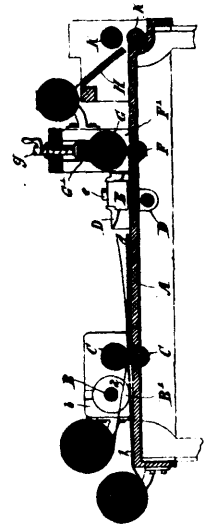

26885 Piamondon & Palmer's Rubber Belting.

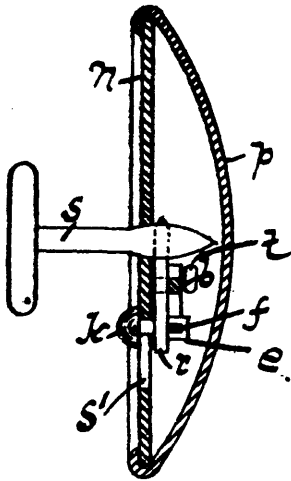

26886 Jones' Button.

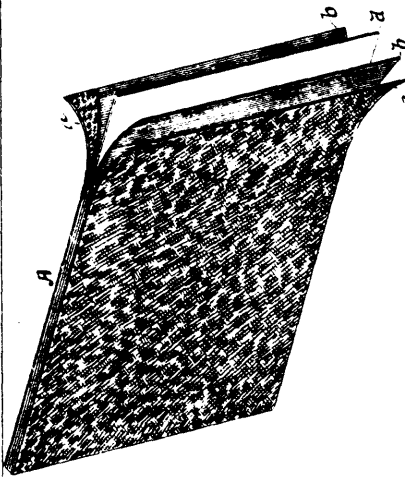

26887 Tuttle's Compound Fabric, etc.

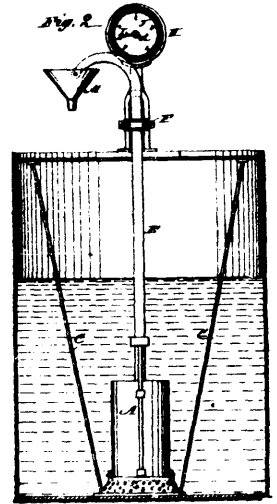

26888 Sims' Measuring Pump.

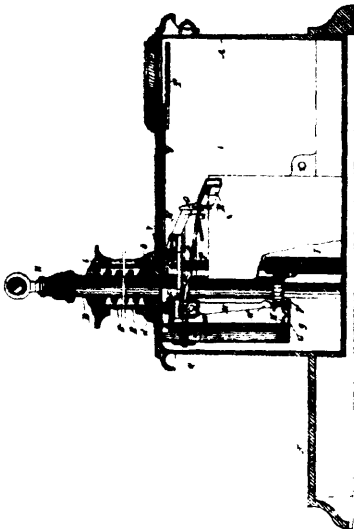

26889 Whitney's Strength Testing Machine.

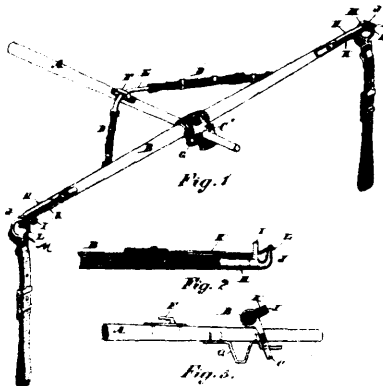

26890 Latsthaw's Neck Yoke.

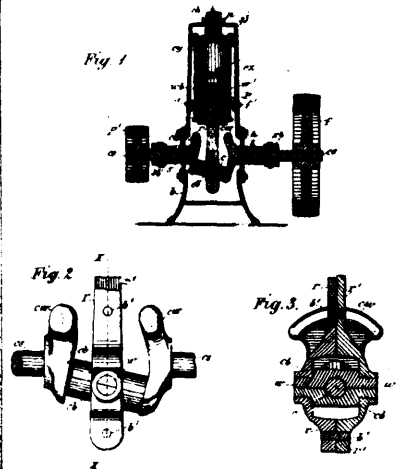

26891 Castle's Steam Engine.

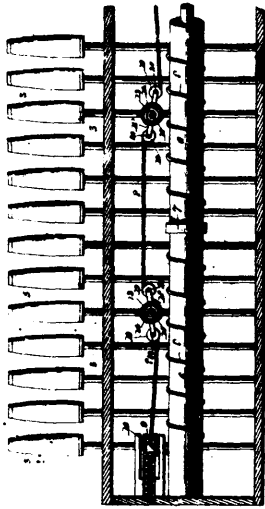

26892 Clark & Williams' system of Banding for Spinning or Twisting Frames.

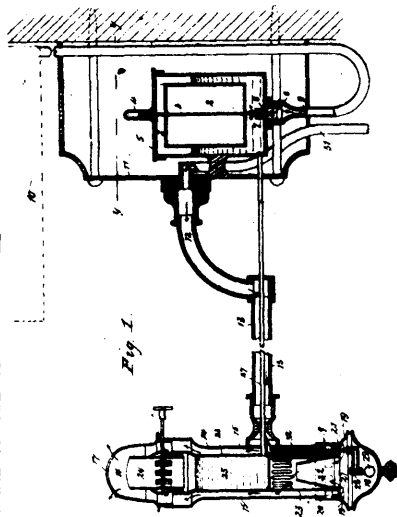

26893 Evans & Ross' Reservoir Lamp.

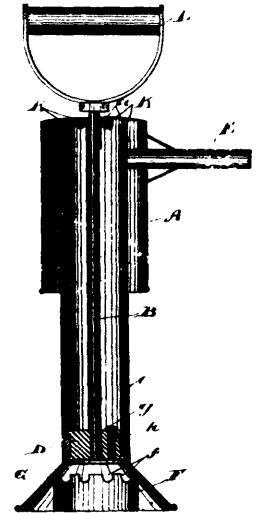

26894 Redfern's Washing Machine.

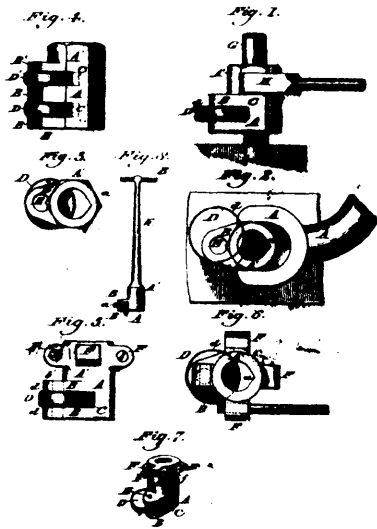

26895 Bowman's Wrench.

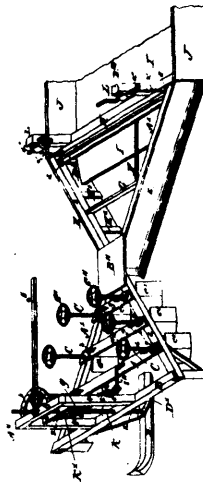

26897 Roberts' Snow Plough.

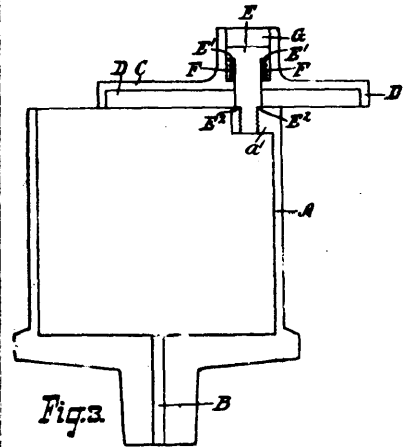

26898 Bailey's Oil Cup.

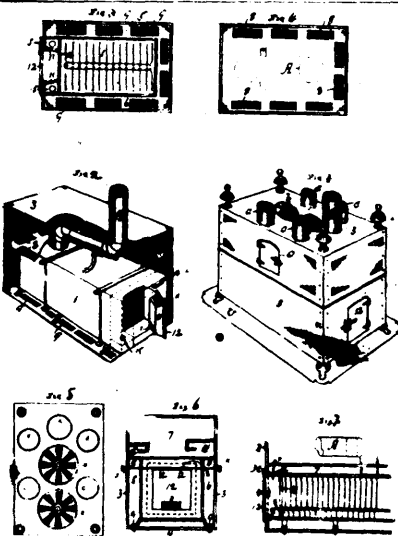

26899 McCrossan's Hot Air Furnace.

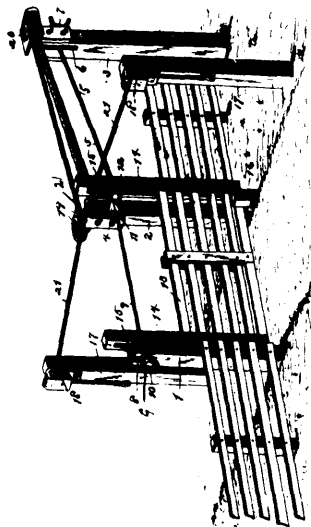

26900 Bassett's Gate.



26901 Wiederer's Triplicate Mirror.

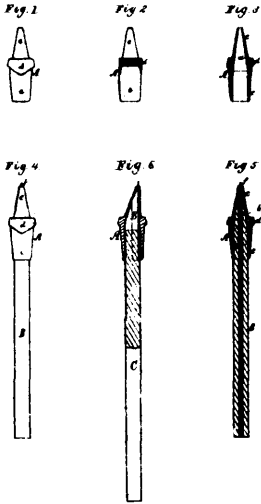

26902 Foster's Erasive Guard for Writing Pencils.

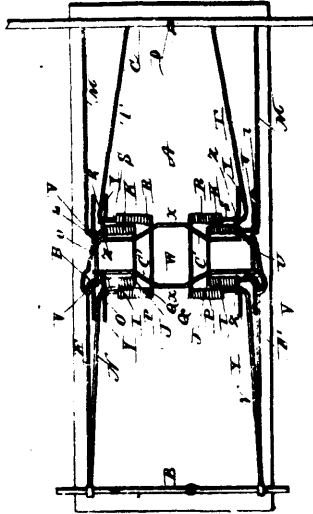

26903 Wolfe's Vehicle Spring.

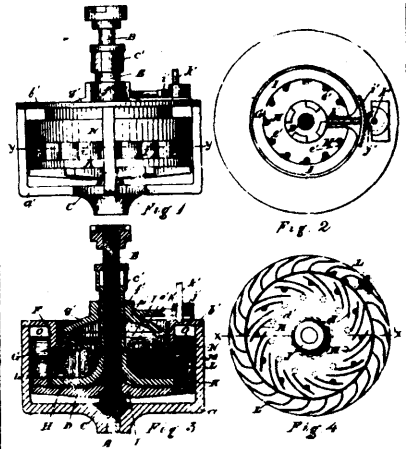

26904 Patrick's Water Wheel.

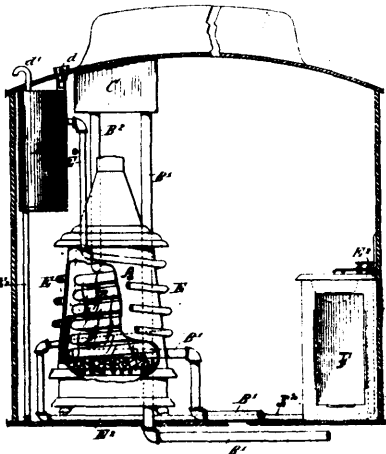

26905 Mann's Heating Apparatus for Railway Cars.

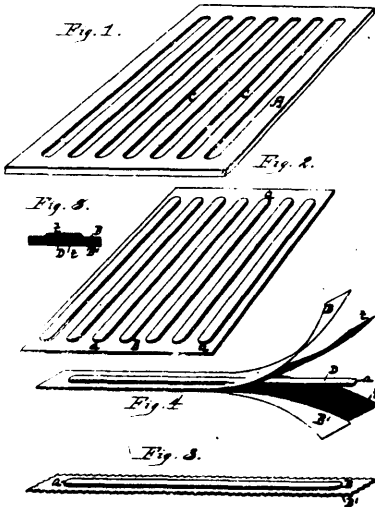

26906 Bowling's Stays for Garments.

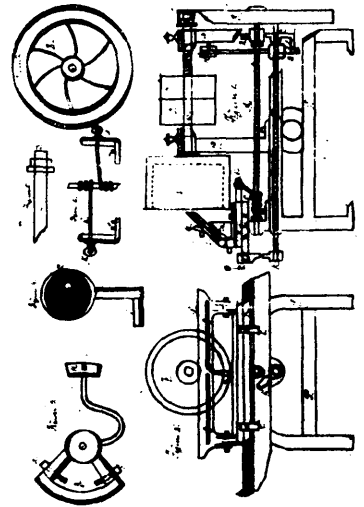

26907 Steinhoff's Machine for Grinding Planing Machine Knives.

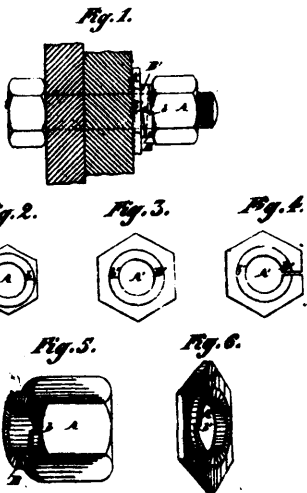

26908 Flamsche & Picard's Nut Lock.

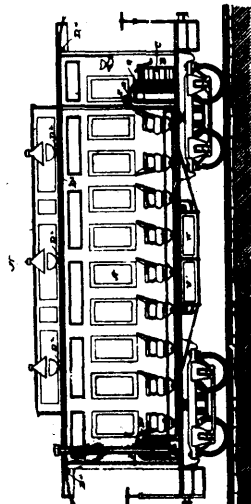

26909 Plass' Apparatus for Lighting and Heating Railway Cars.

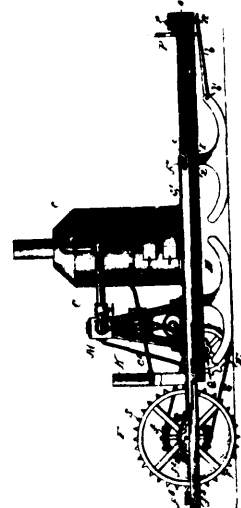

26910 Glover's Traction Road Engine.

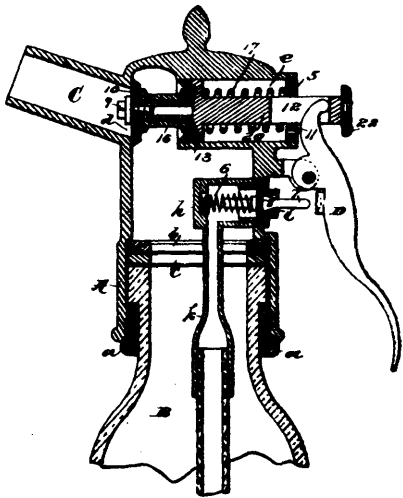

26911 McArdle's Vent Faucet for Bottles.

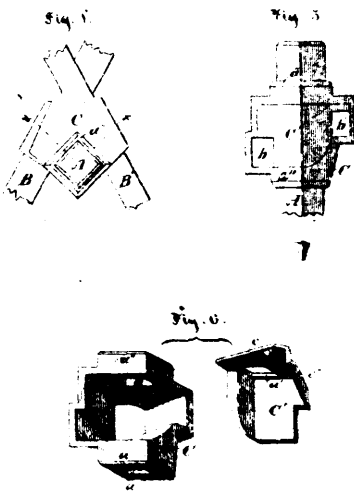

26912 Callander's Harrow.

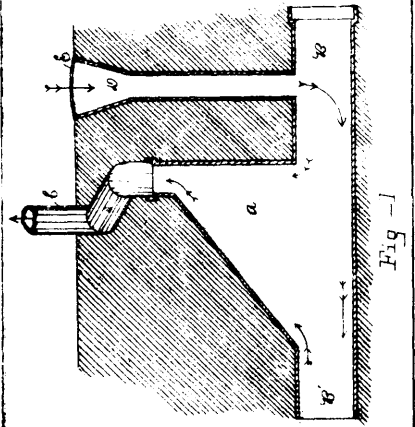

26913 McAndrew's Sewer Ventilator.

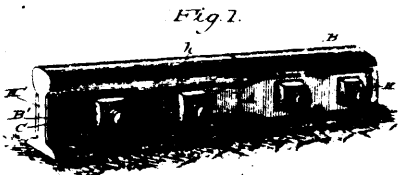

26914 Castle's Nut Lock.

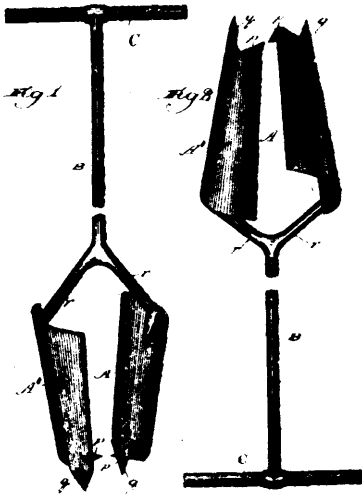

26915 Iwan's Earth Auger.

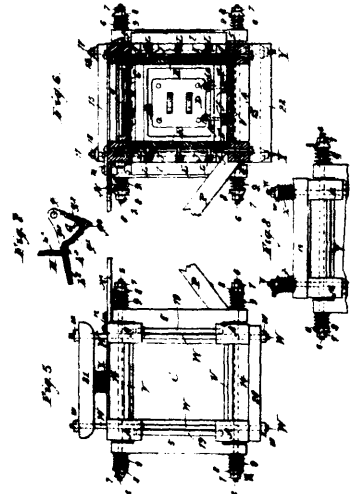

26916 Ertel's Baling Press.

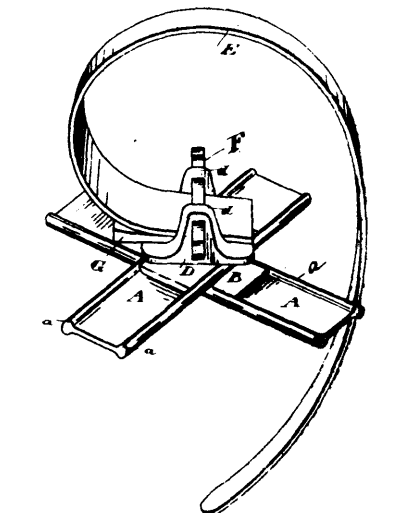

26917 Bailey's Harrow and Cultivator.

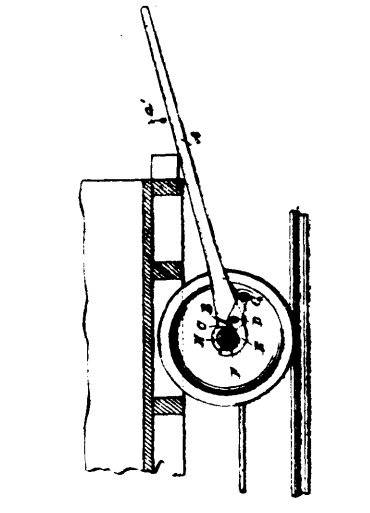

26918 Duplessis' Car Mover.

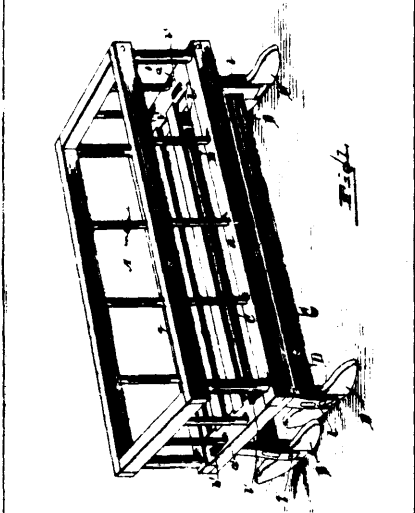

26919 Pettis' Crib and Cradle for Children.

Fig. 1.

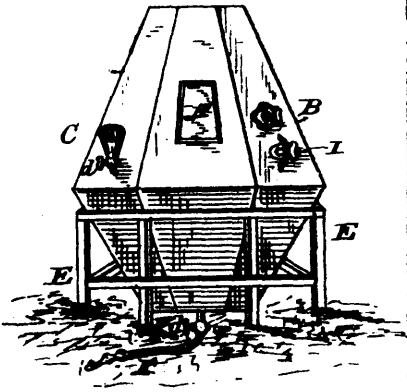

26920 Harker's Anti-Parasitic Apparatus.

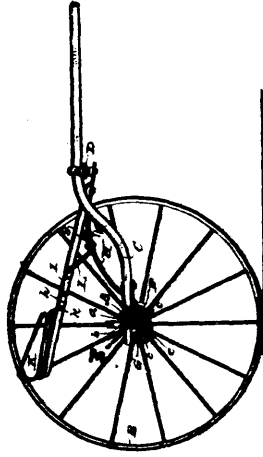

26921 Beebe's Two-Wheeled Vehicle.

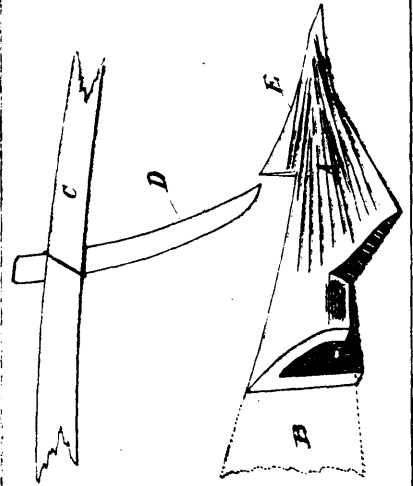

26922 Johnston's Land Plough.

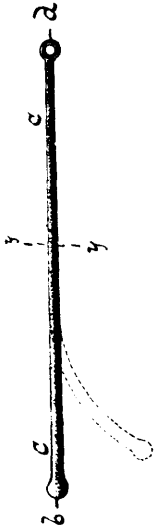

26923 Francke's Surgical Instrument.

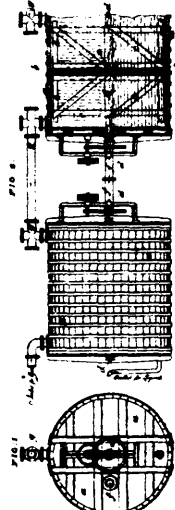

26925 Walton's Manufacture of Acids, etc., and Apparatus therefor

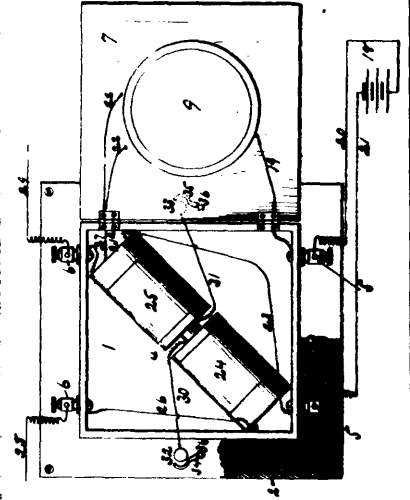

26926 Burnley's System of Telephony.



26927 Bell's Wax Match and Lighter.

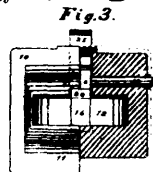
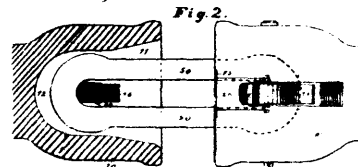
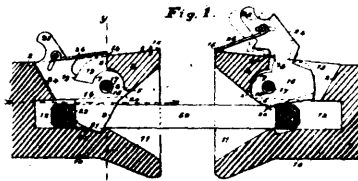

26928 Chisholm's Car Coupling.

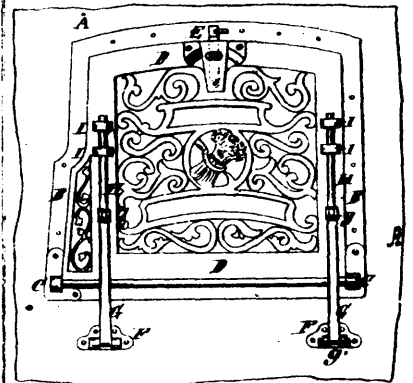

26929 Culver's Drop Door for Ovens.

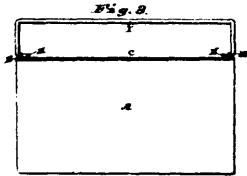
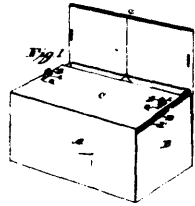

26930 Smith's Paper Box.

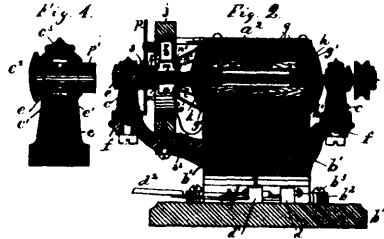
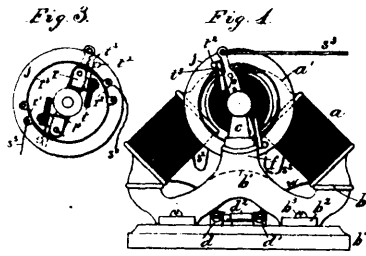

26931 Baxter's Electric Motor.

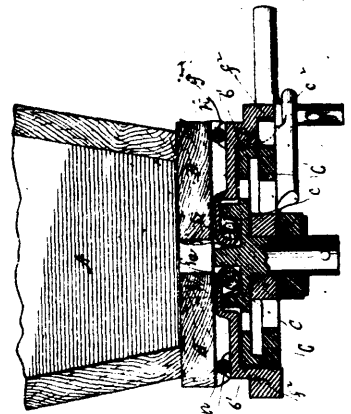

26932 Kirkpatrick's Grain and Grass Seeder.

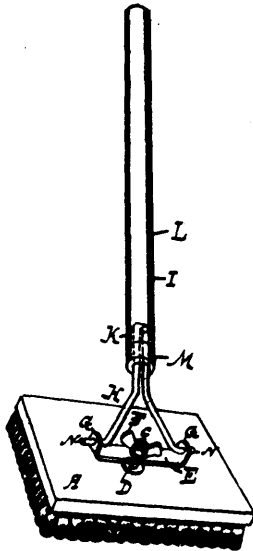

26934 Chamberlain & Lamb's Scrubbing Brush.

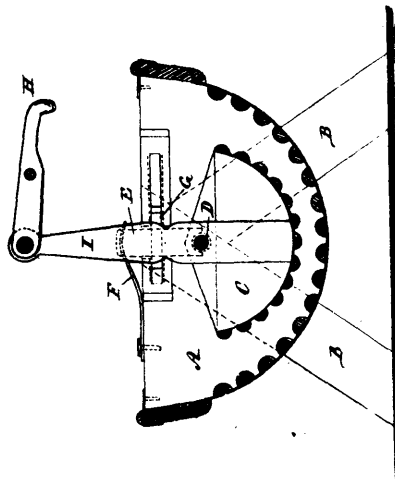

26935 Murdock's Washing Machine.

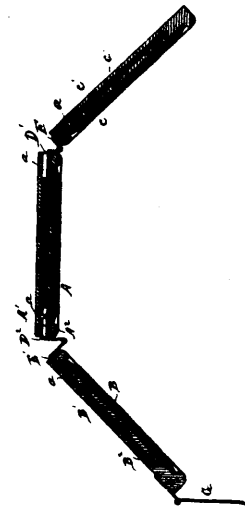

26936 Hufeland's Triplicate Mirror.

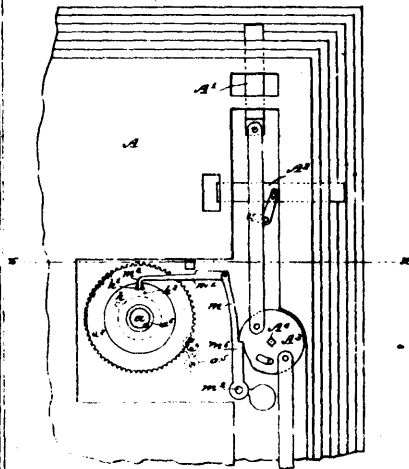

26937 Griffin's Combination Lock.

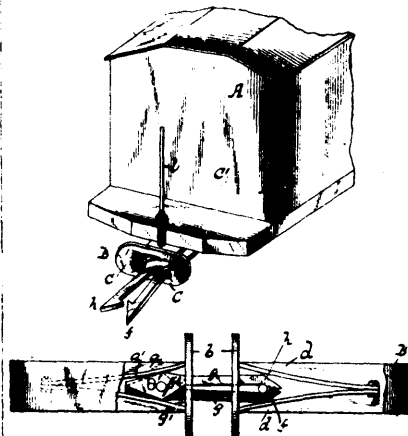

26938 Wilson's Car Coupling.

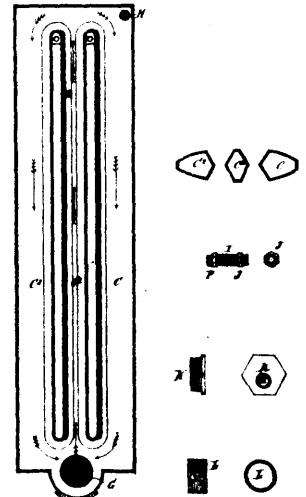

26939 Tomkins & Williams' Steam Radiator.

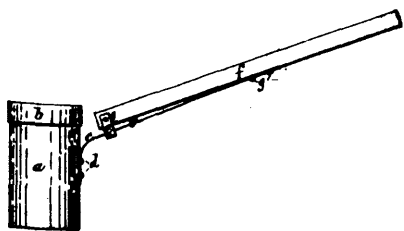

26940 Grobb's Machine for Sprinkling Insect Powder.



26941 Gorse's Barbed Wire Fencing.

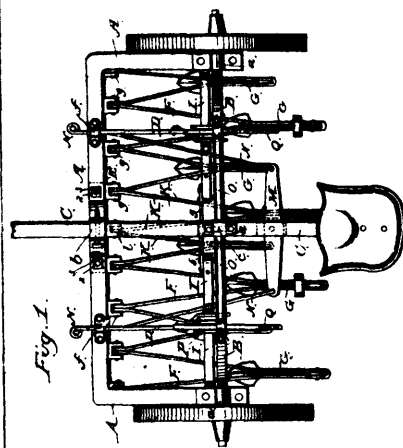
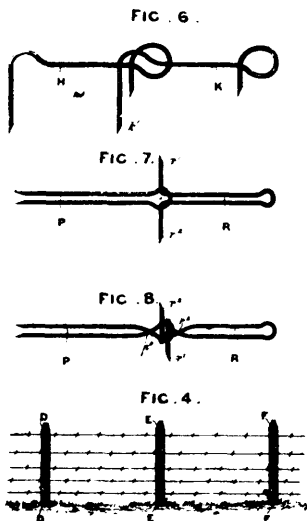

26942 Trump's Cultivator.

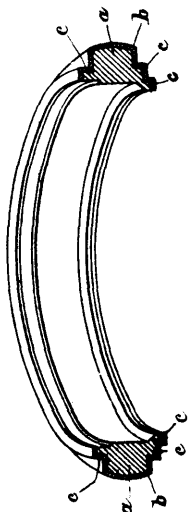
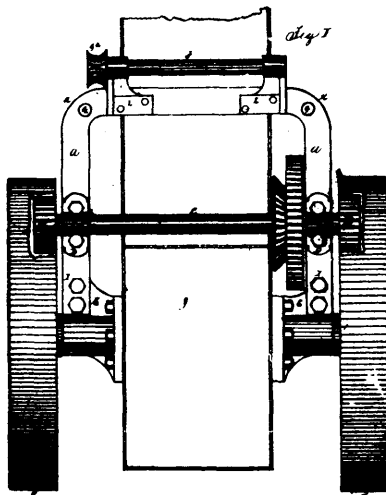
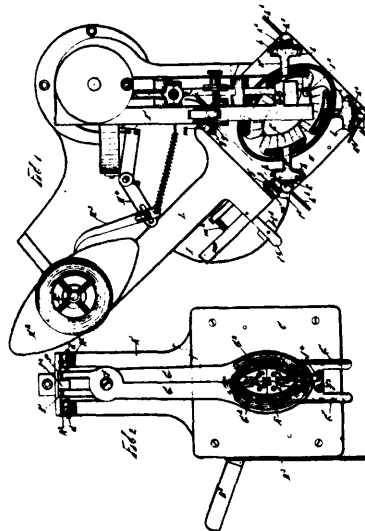

FIG. 1.

26943 Morrill's Watch Case.



26944 Longhurst's Traction Engine.



26945 Arnold's Attachment for Sewing Machines.

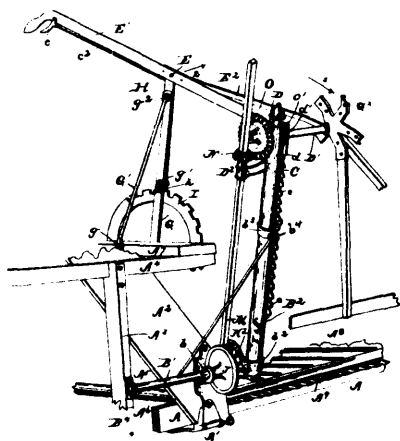

26946 Steward's Harvester Reel.

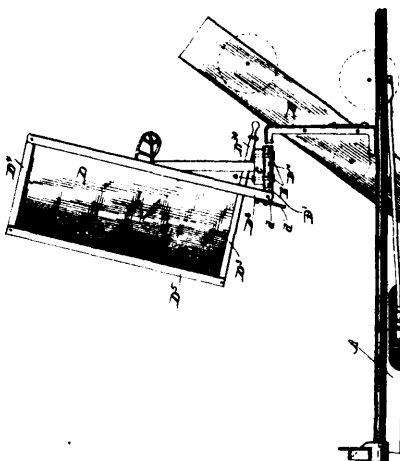

26947 Dixon & Steward's Harvester Back Board.

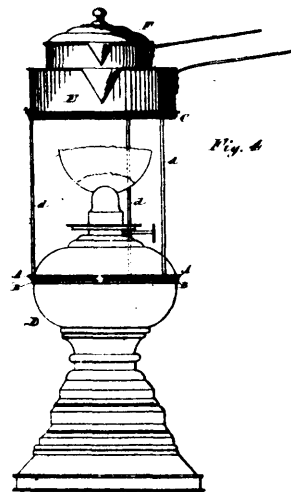

26948 Bassemir's Lamp Frame.

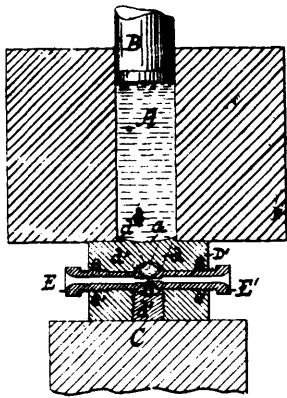

26849 Robertson's Hydraulic Press for Coating Wire, etc., with Lead.

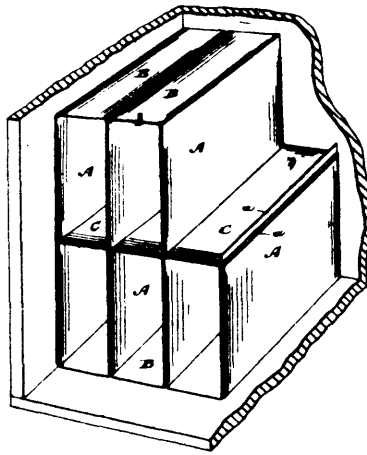

26950 Lash's Metallic Pigeon Hole Case.

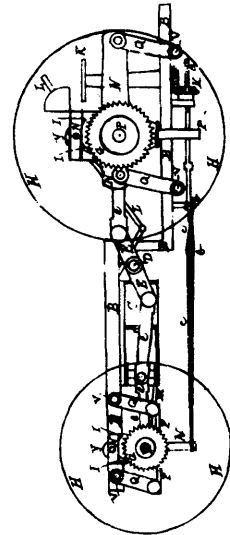

26951 Rose's Traction Engine.

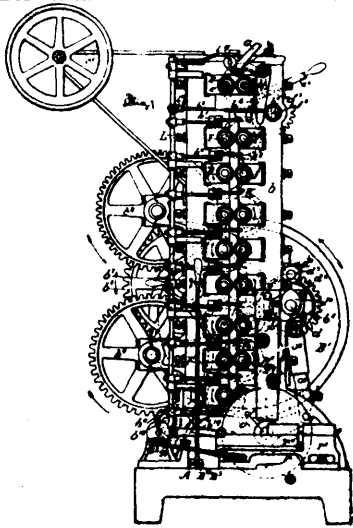

26952 Capewell's Horseshoe Nail Machine.

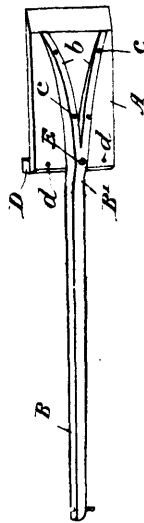

26953 McLaren's Snow Shovel.

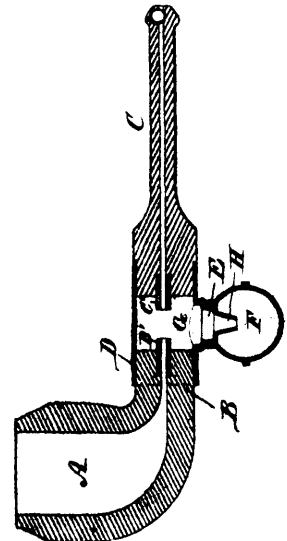

26954 Bruneau's Tobacco Pipe.

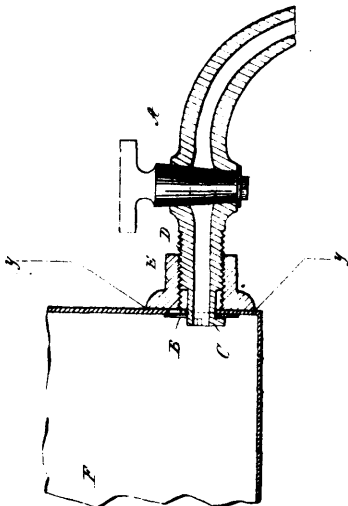

26955 Beach's Faucet.

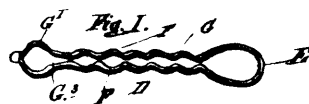

Fig. 2.

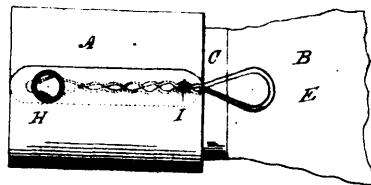
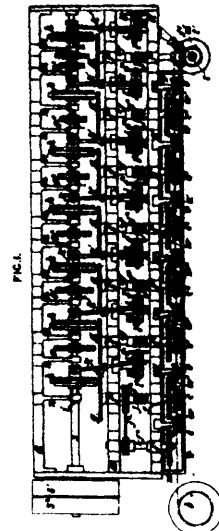

Fig. 4.



26956 Barrow's Cuff Fastener.



26957 Robert's Wire Drawing Machine.

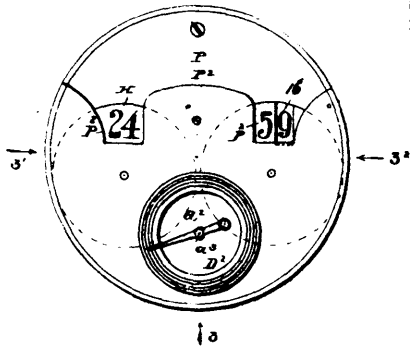

26958 Pallweber's Time Piece.

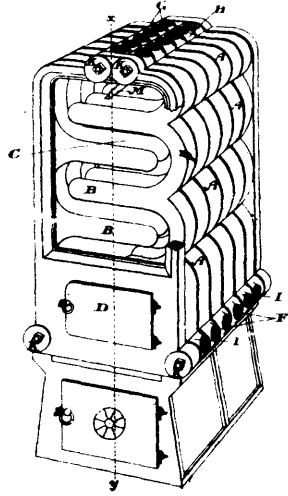

26959 Plaxton's Hot Water Sectional Boiler.

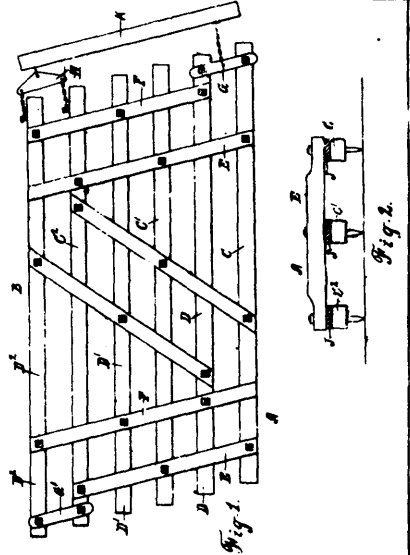

26960 Paddock's Harrow.

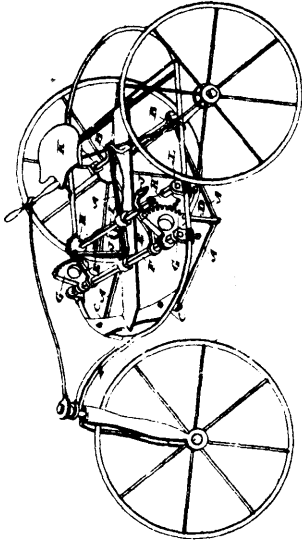

26961 Burkholder's Propelling Gear for Vehicles.

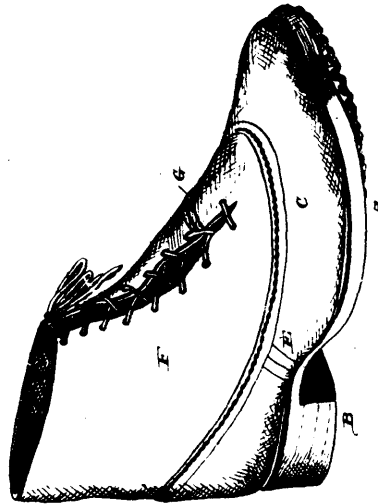

26962 Maurer's Shoe

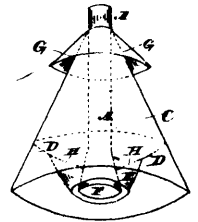
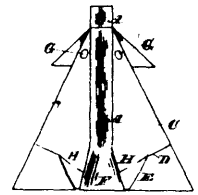

26963 Hazlitt's Washing Machine.

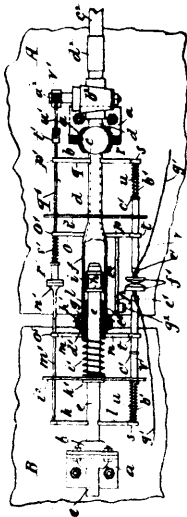

26964 Deacon's Steam and Electric Connections for Cars.

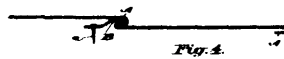
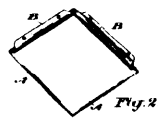
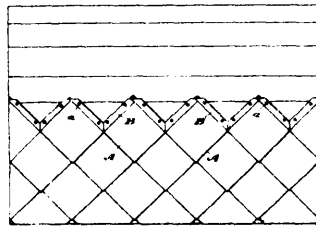

26965 Green's Metal Shingle

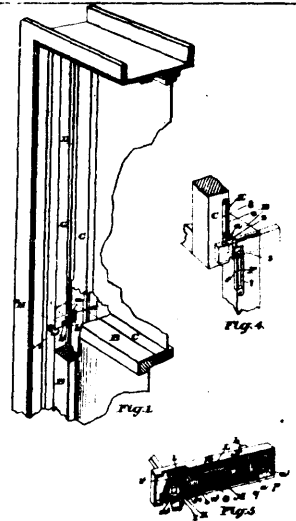

26966 Clarke's Window Fastener

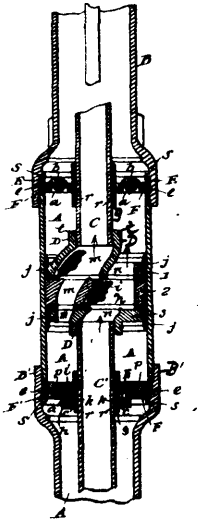

26967 Putnam's Pump.



26968 Steward's Harvester.

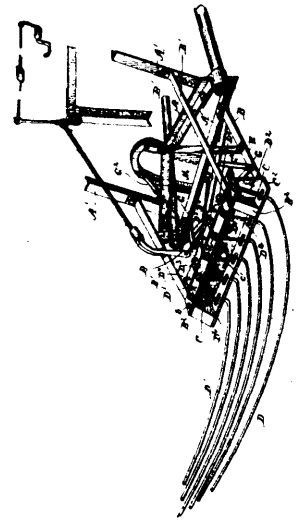

26969 Steward & Kennedy's Bundle Carrier for Harvesters.

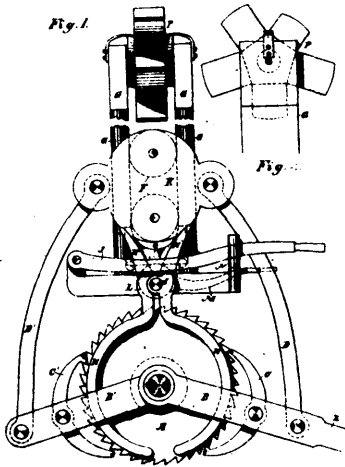

26970 Roe's Saw Mill Set Works.

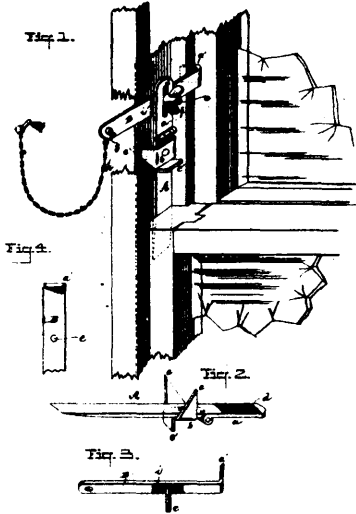

26971 Abrams' Window Fastener.

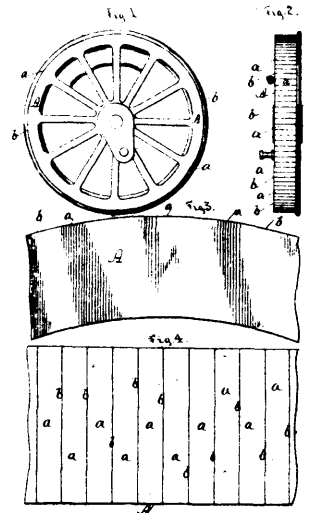

26972 Swinerton's Driving Wheel of Locomotives.

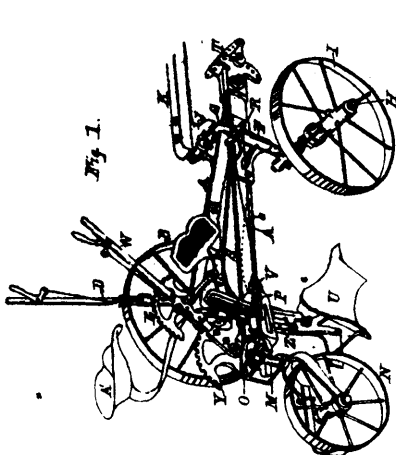

26973 Gale's Sulky Plough.

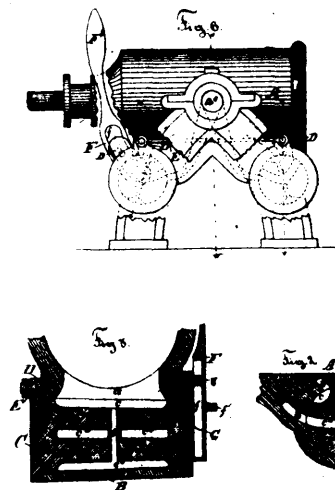

26974 Milne's Slide Valve.

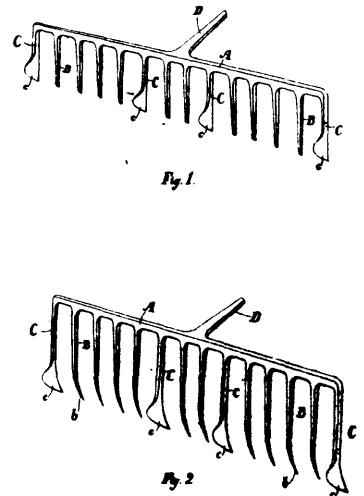

26975 Catef's Garden Rake.

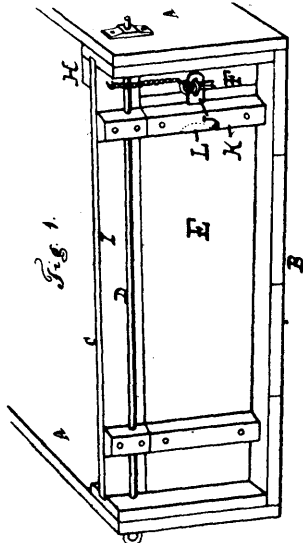

26976 Tyler's End Gate for Waggon.

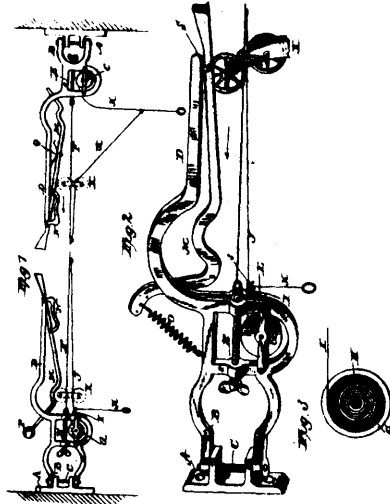

26977 Algie's Store Service Apparatus.

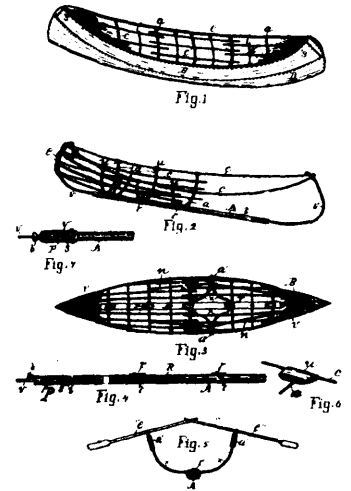

26978 King's Portable Boat.

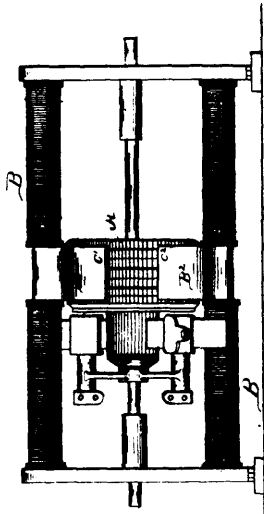

26979 Easton's Electric Motor.

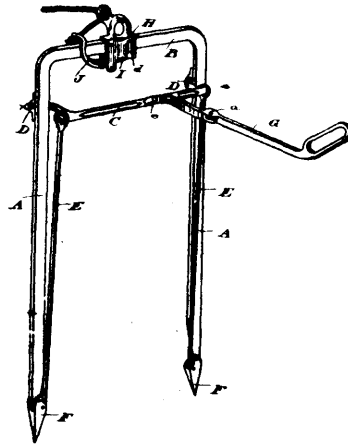

26980 Provan's Hay Fork.

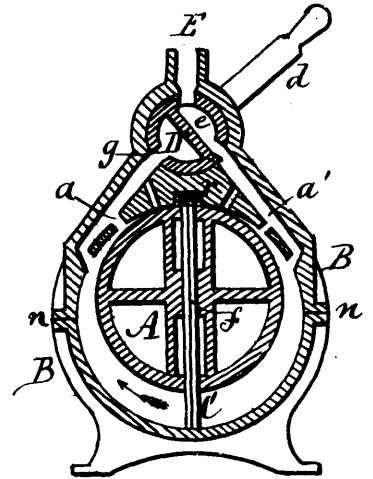

26981 Ainsworth's Engine.

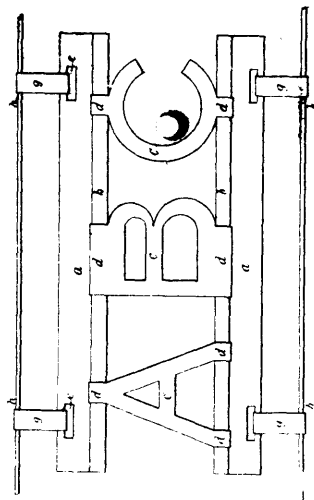

26982 Barnsdale's Device for Advertising on Wire Fences.

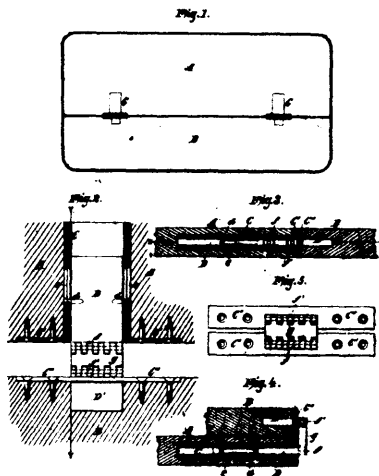

26983 Crawford's Concealed Hinge.

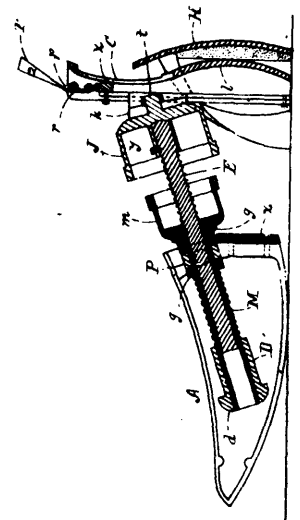

26984 Donovan's Last.

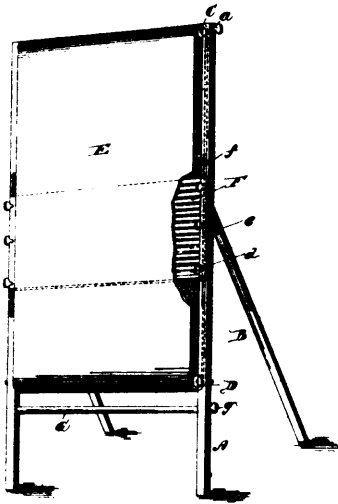

25985 Russell's Blackboard.

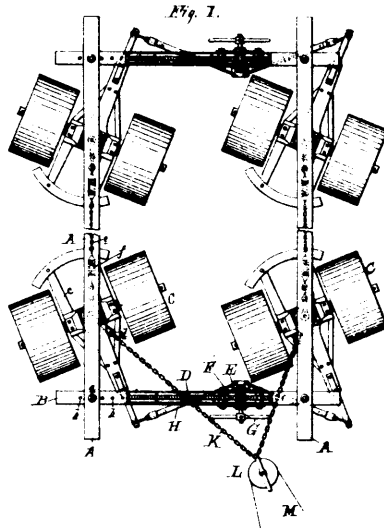

26986 Goodman's Truck for Moving Houses.

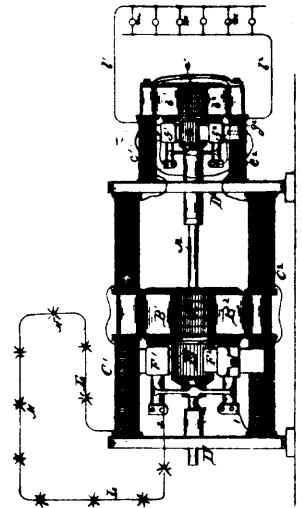

26887 Easton's Dynamo Electric Generator.

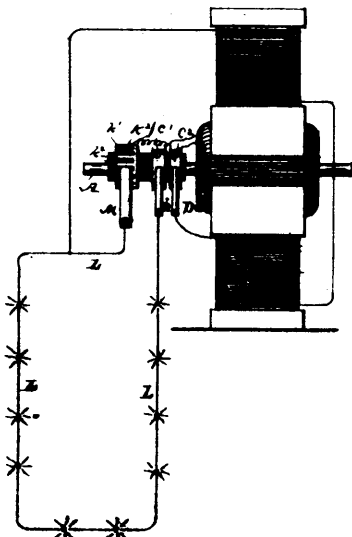

26988 Easton's Electric Generator.

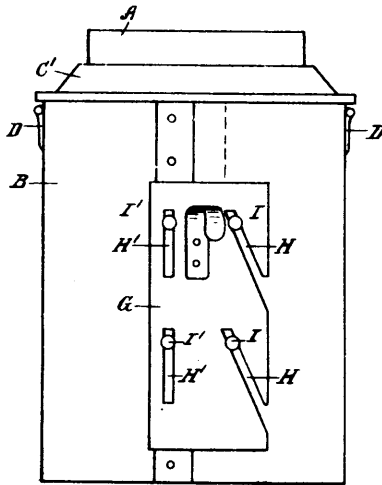
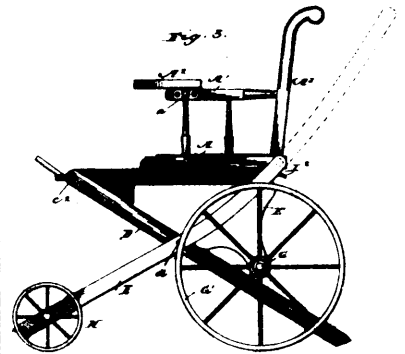
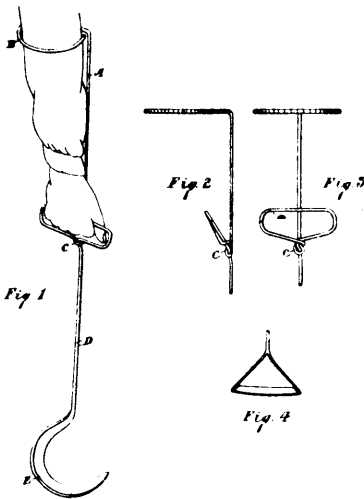

Fig. 1.

26990 Sabin's Concrete Tile Moulding Machine.



26991 Kenna's Convertible Chair.



26992 Calef's Tool Handle.

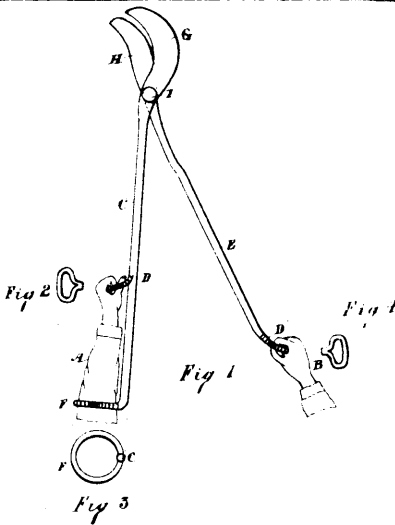

26993 Calef's Pruning Shears.

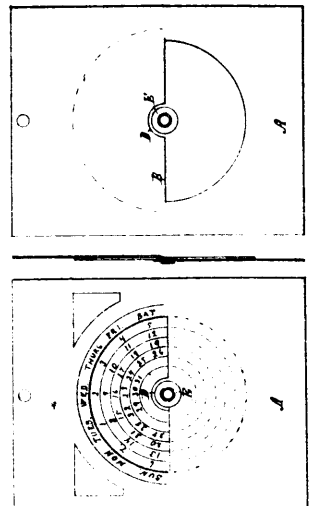

26994 Vine's Perpetual Calendar.

Fig. 1.



26995 Randel's Hat Sweat.

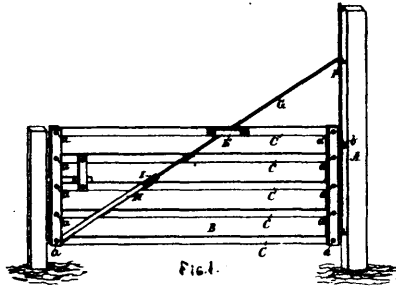

Fig. 1.

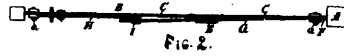
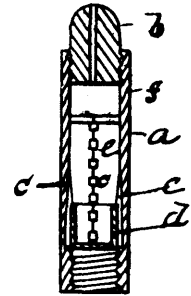

Fig. 2.

26996 Shedd's Gate.



26997 Metcalf's Gas Pressure Regulator.

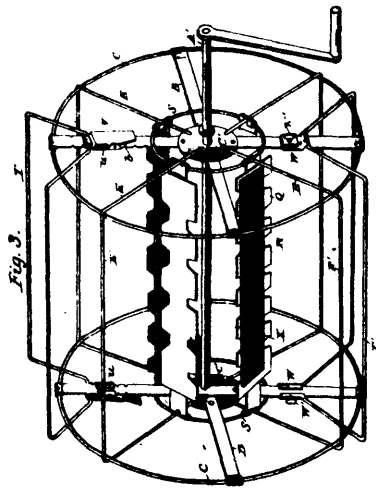
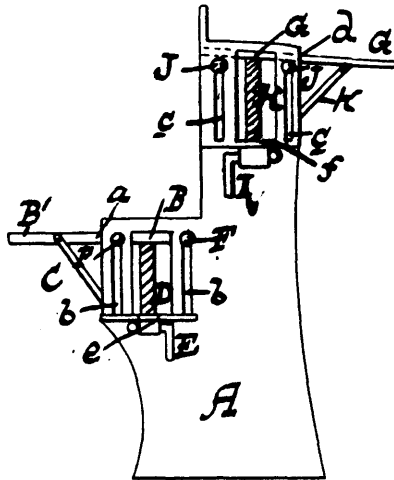

Fig. 3.

26999 Saunders' Dish Washer.



27000 Dohie's School Desk and Seat.

Fig. 1.

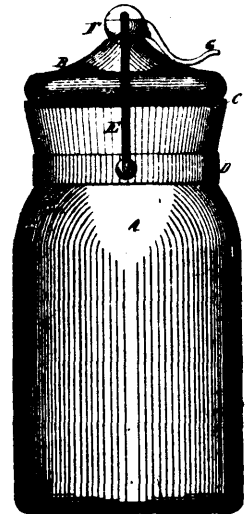

27001 Hemingray's Jar Top Fastener

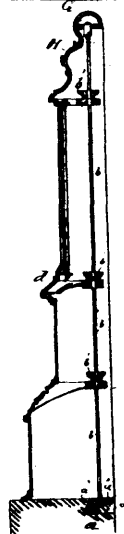

27003 Miller's Sectional Monument.

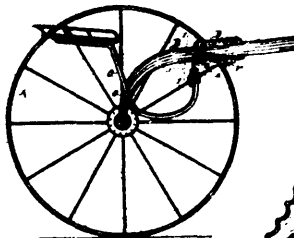

Fig. 1.



Fig. 4.



Fig. 3.

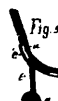

Fig. 5.



Fig. 6.

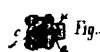
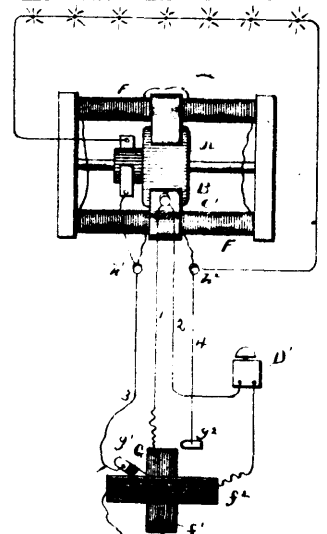
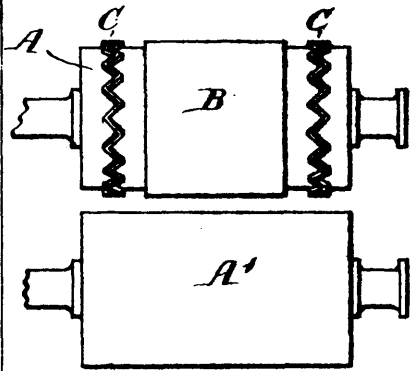

Fig. 2.

27004 Howard's Two-Wheeled Vehicle.



27005 Easton's Method of Discovering Short Circuits in Electrical Machines.



27006 Howard's Articles Manufactured from Pulp.

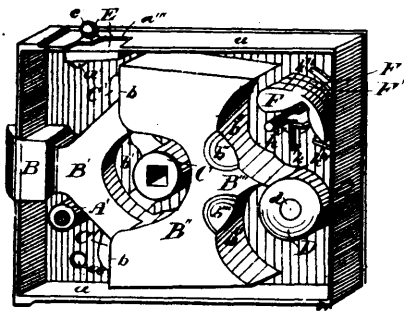

27008 Sanford's Combined Latch and Lock

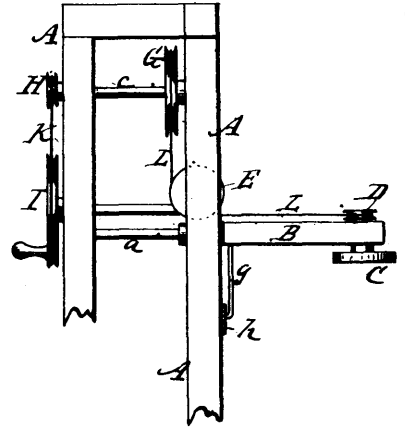

27009 East's Machine for Grinding Horse Shoe Calks.

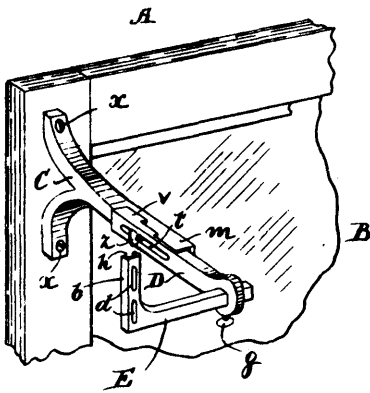

27010 Strang's Curtain Fixture.

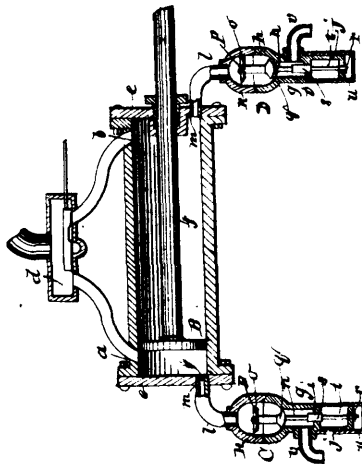

27011 Boudreaux's Valve Attachment for Steam Cylinders.

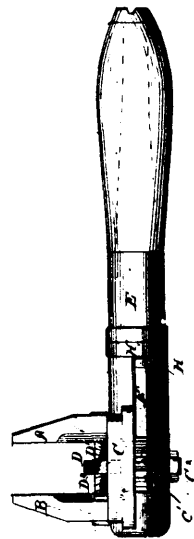

27012 Day's Ratchet Wrench.

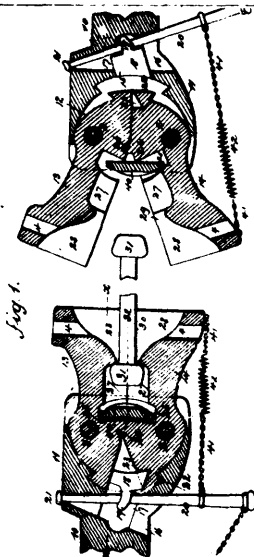

27013 Flett's Car Coupler and Uncoupler.

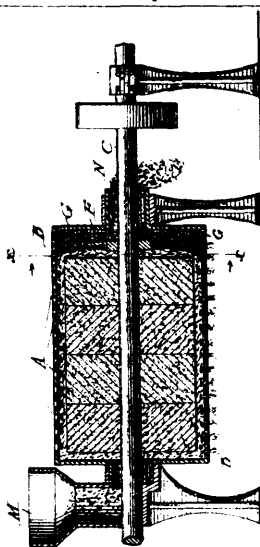

27014 Webb's Machine for Pearling Barley, Wheat, etc.

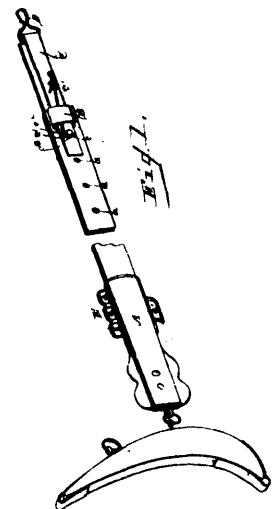

27015 Granler's Harness

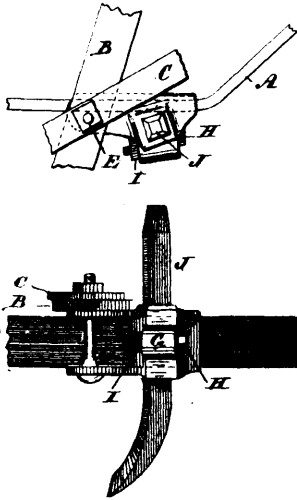

27016 Bunn's Harrow Cultivator

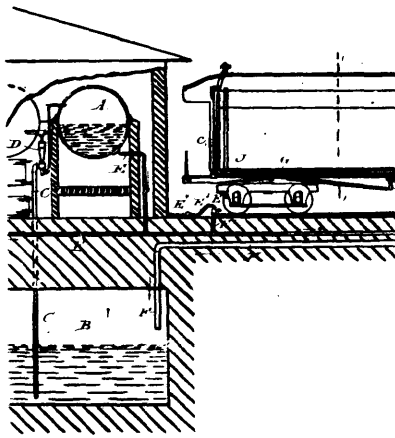

27017 Elder's System of Heating Railway Cars.

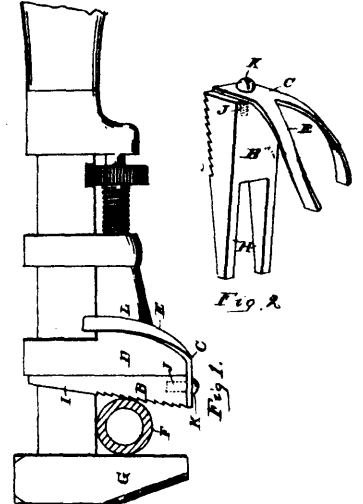

27019 Kelly & Hubbell's Wrench Attachment.

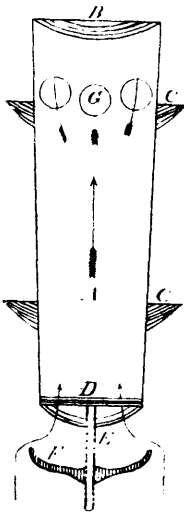

27020 Williams' Fire Arrester

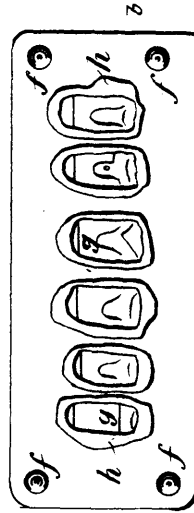

27021 Jones' Apparatus for Manufacturing Artificial Teeth

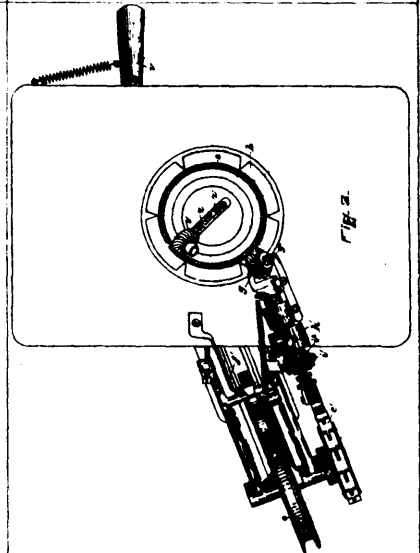

27022 Covell & Cram's Stocking and Means for Knitting.

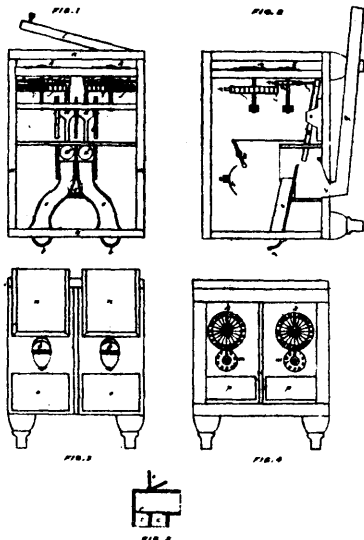

27023. Jones' Machine for Registering Votes.

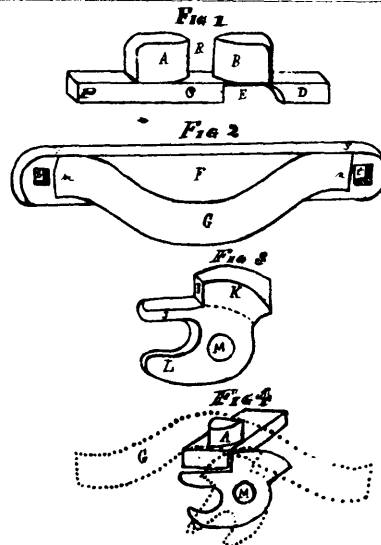

27024 Henderson's Machine for Unloading Hay.

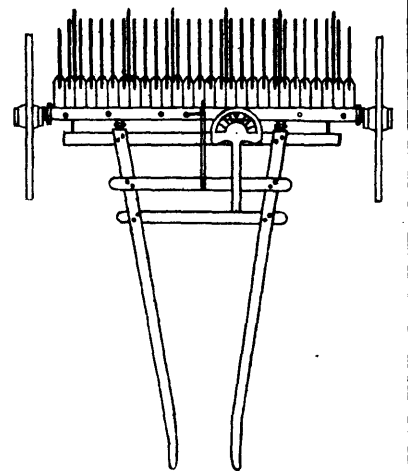

27025 Chapman's Wheel Rake

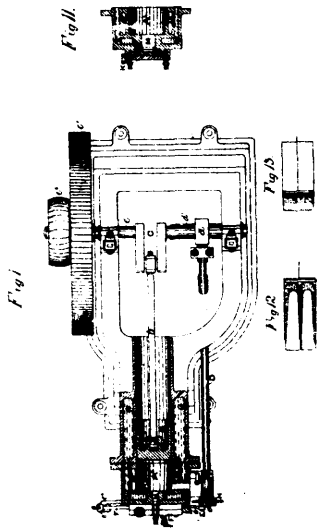

27026 Rollason's Gas or Vapour Engine.

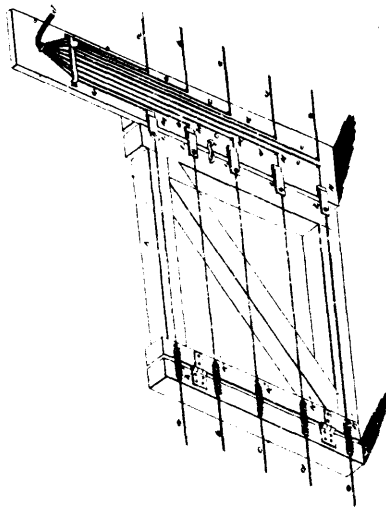

27027 Wilson's Electric Fence.

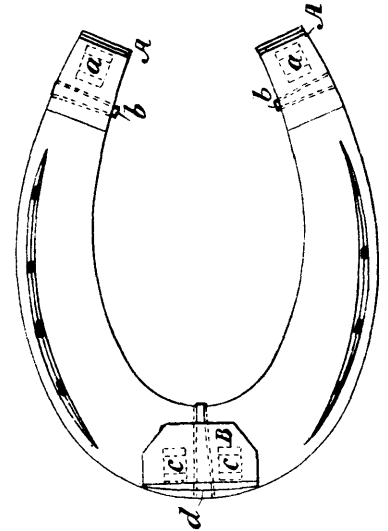

27028 Melius' Horse Shoe.

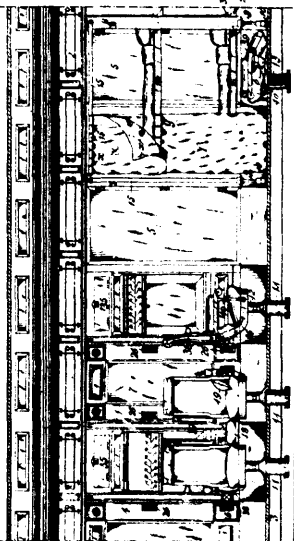

27029 Leve's Railway Car.

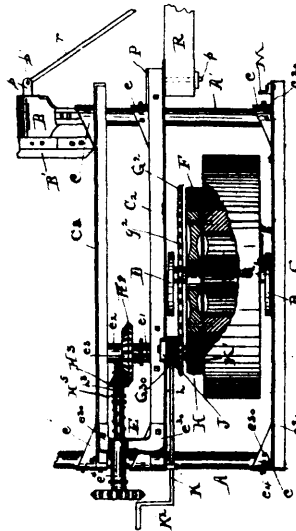

27030 Kennedy's Harvesting Machine.

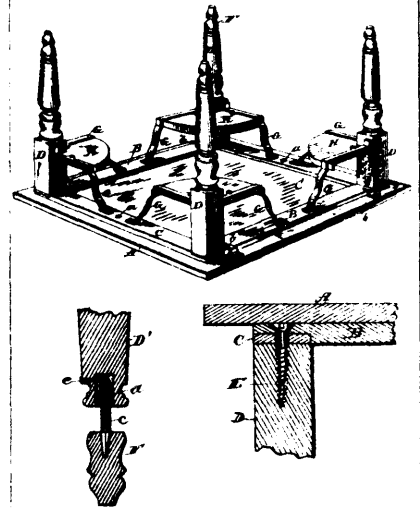

27031 Moeller's Table.

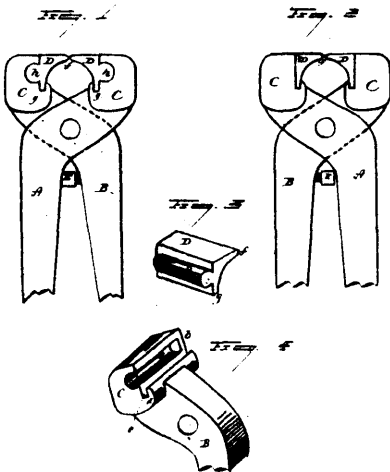

27032 Donovan's Cutting Nippers.

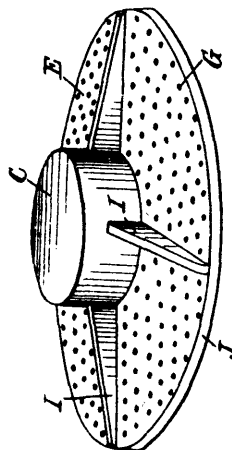

27033 Frasch's Apparatus for Refining Petroleum.

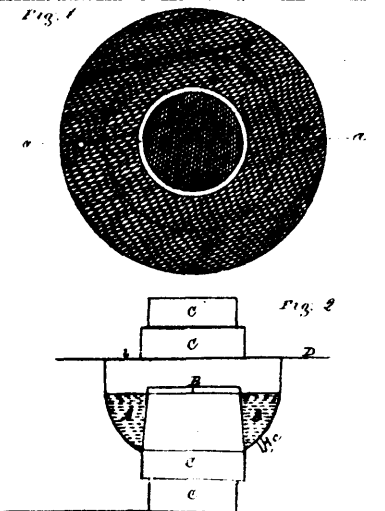

27034 Ketchabaw's Stove Draught.

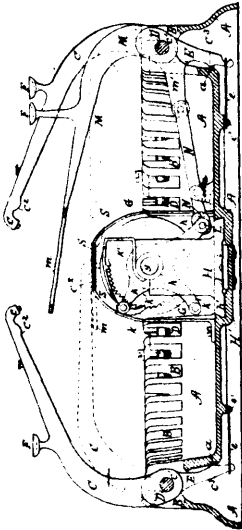

27035 Myer's Type-Writing Machine.

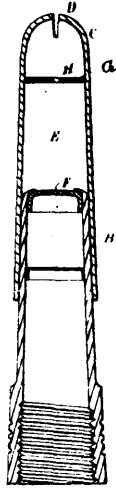
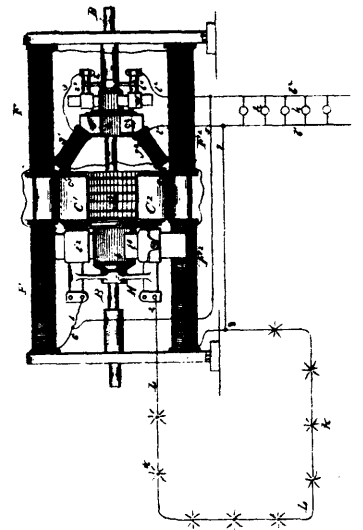
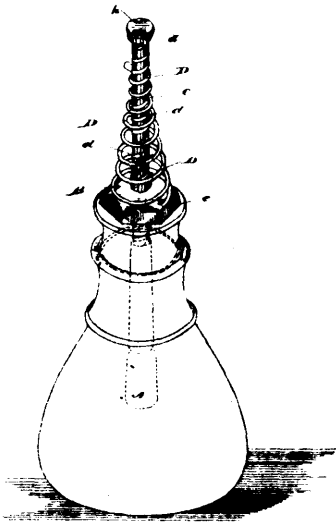

Fig. 2

27036 Calef's Gas Burner.



27037 Easton's Dynamo Electric Machine.



27038 Rodden's Muclage or Glue Bottle.

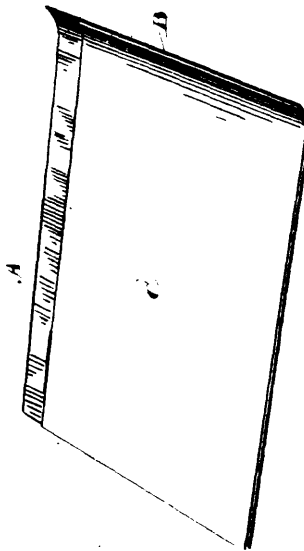

27040 Sale's Process of Manufacturing Paper Covers, etc.

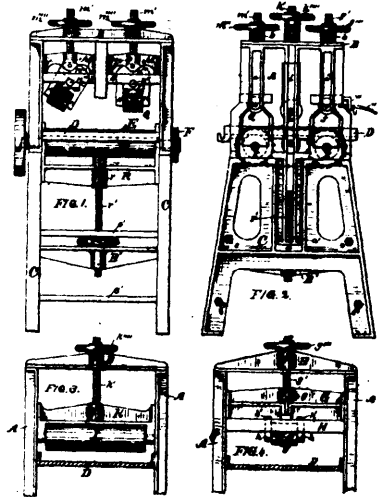

27041 Burdett's Machine for Ornamenting Wood, etc.

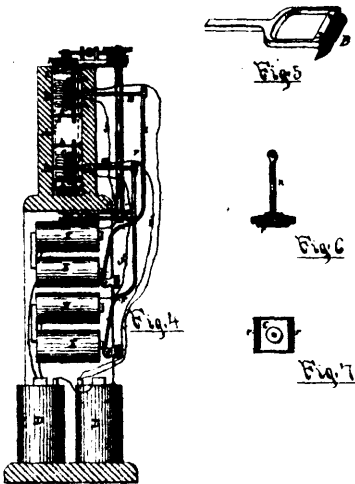

27044 Hay & Laass's Marking and Stamping Apparatus.

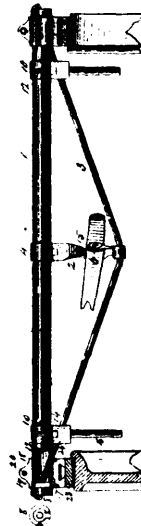

27045 Hien's Brake Beam for Railway Cars.

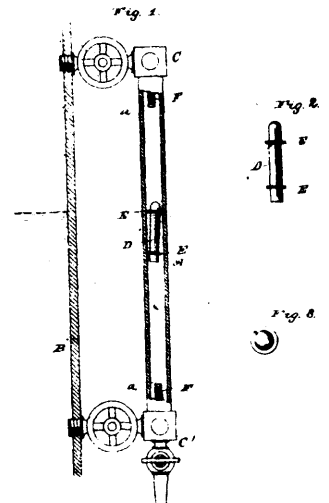

27046 Campbell's Water Gauge for Steam Boilers.

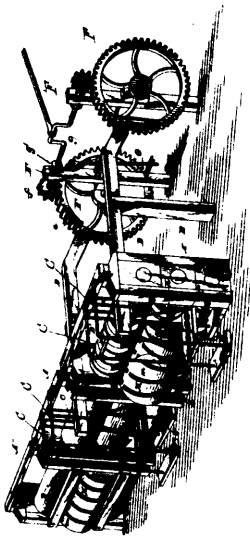

27047 Duff's Roller Mill.

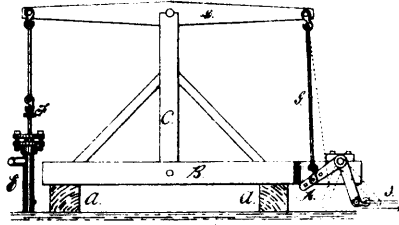

Fig. 1.

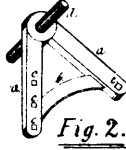
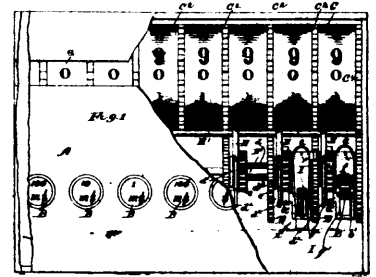
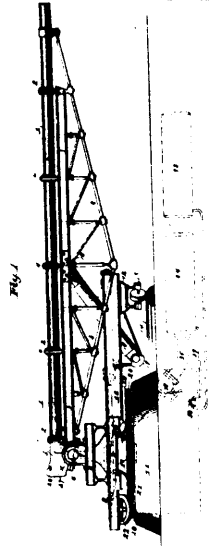

Fig. 2.

27048 Saunders' Bell Crank.



27049 Fisk's Cash Tally or Adding Machine.



27050 Pratt's Pneumatic Gun.

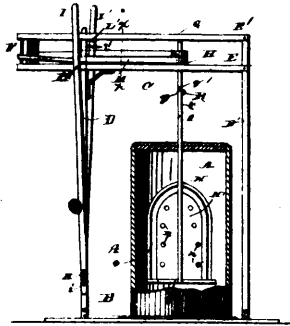

27051 Wayland's Churn.

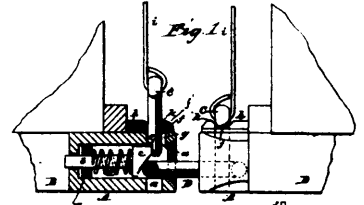

Fig. 1.

Fig. 2.

Fig. 3.

Fig. 4.

27052 Self's Car Coupling.

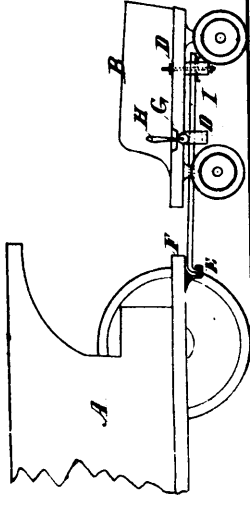

27053 St. John's Traction Bar for Locomotives.

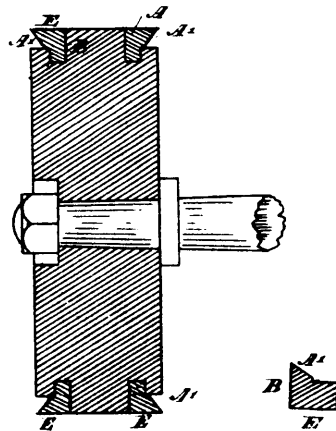

27054 St. John's Piston Packing Ring.

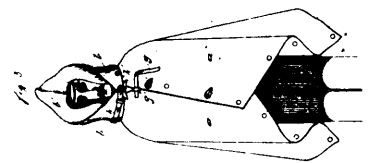

27055 King's Blanket and Overcoat.

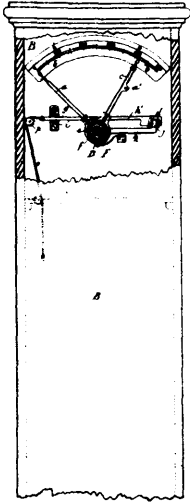

27056 Everitt's Apparatus for Indicating the Force of a Blow on a Coin, etc.

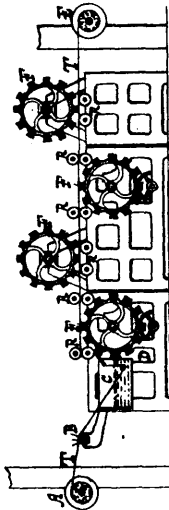

27057 Burns' Apparatus for Polishing Warp Threads.

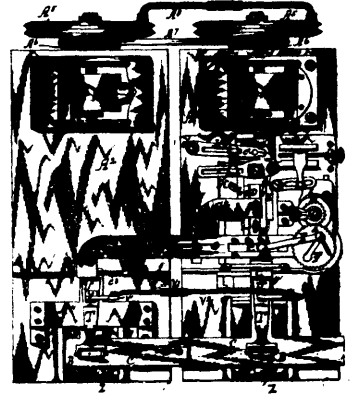

27058 Randel's Button Hole Sewing Machine.

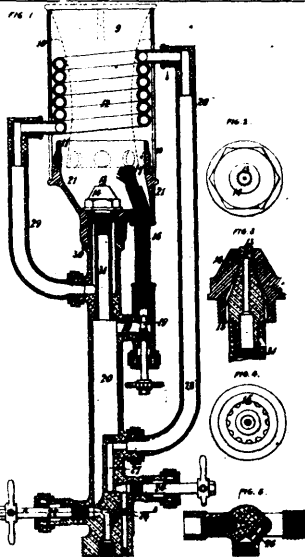

27059 Hannay's Spray Lamp or Burner.

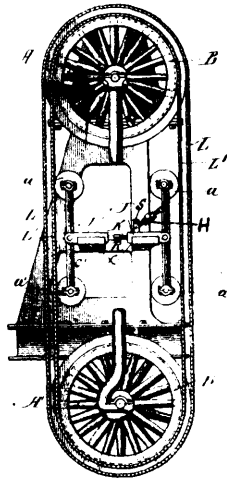

27060 Gage's Band Saw Mill.

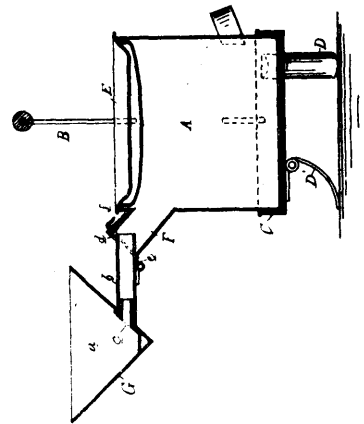

27061 Perry's Milk Bucket.

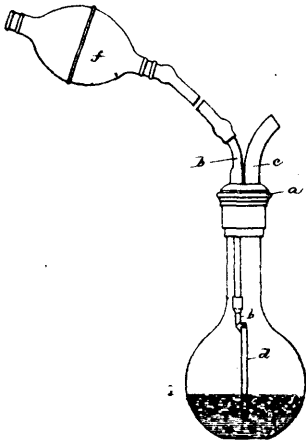
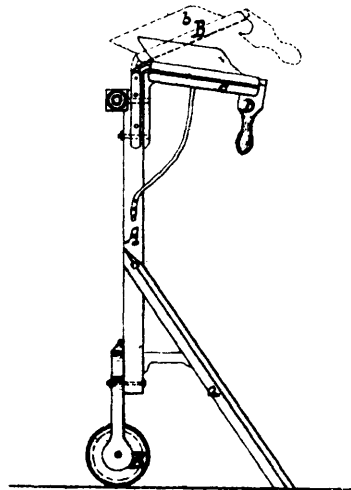
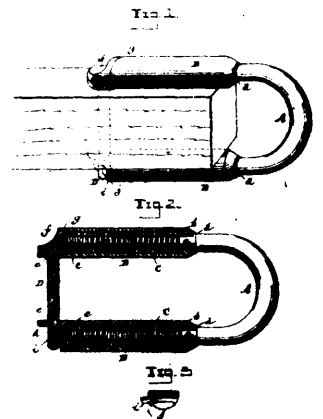

Fig. 1

27062 Lighthill's Atomizer



27063 Hogarth's Bag Holder and Truck.



27064 Morey's Clevis for Attaching to Plough Beams, etc.

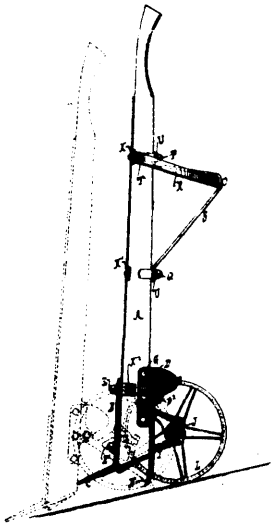

27065 Wing's Hand Truck.

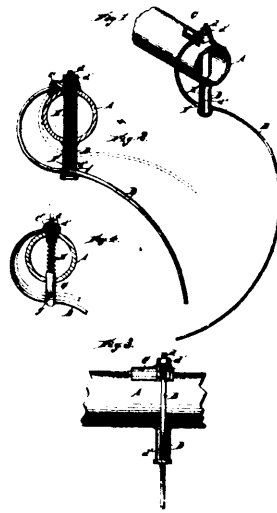

27066 Roberts' Horse Hay Rake.

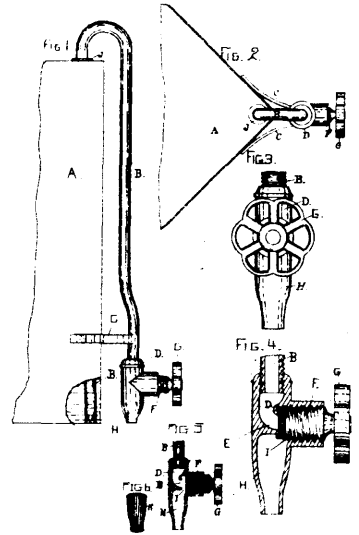

27067 Arper's Siphon

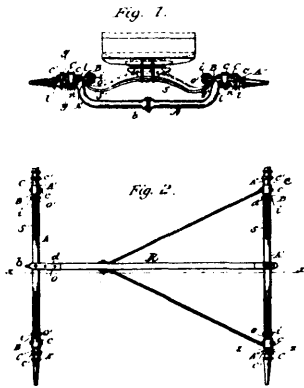

27068 Carpenter's Spring Vehicle.



27069 Shaw's Rubber Boot.

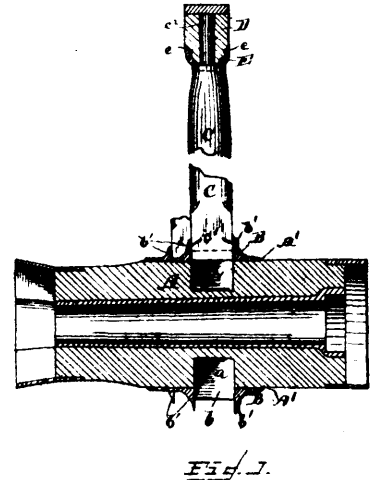

27070 Smith's Vehicle Wheel.



27071 Harford's Remedy for Respiratory Organs

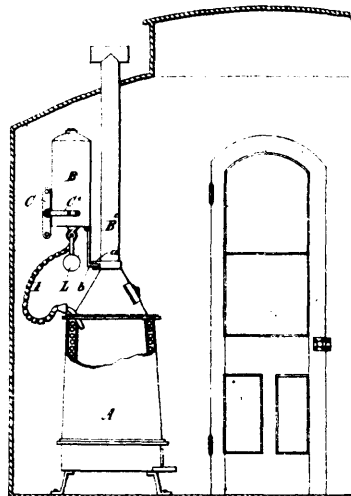

27072 Jamieson's Safety Appliances for Railway Cars.

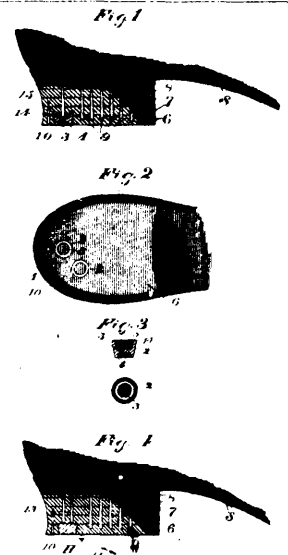

27073 Hull's Heel Protector.

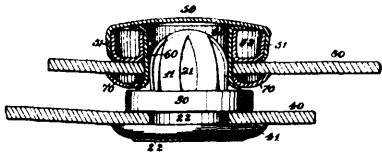

27074 Raymond's Button.

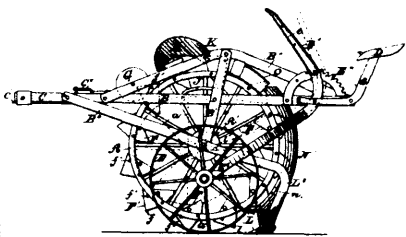
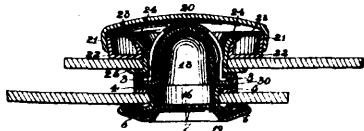

27075 Carter's Ditching and Excavating Machine.

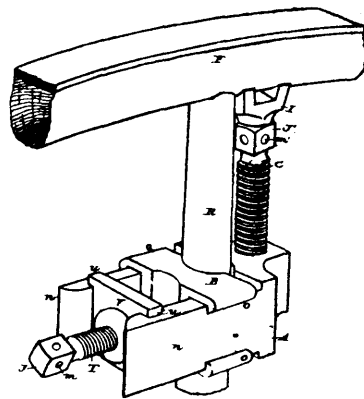
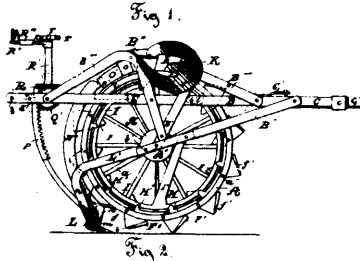

27077 Hammond's Machine for Tightening Wheels.

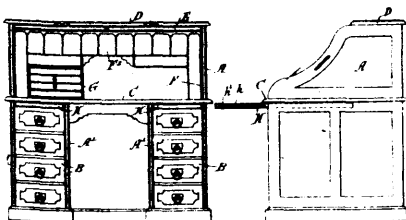

27078 Tees & Calder's Desk.

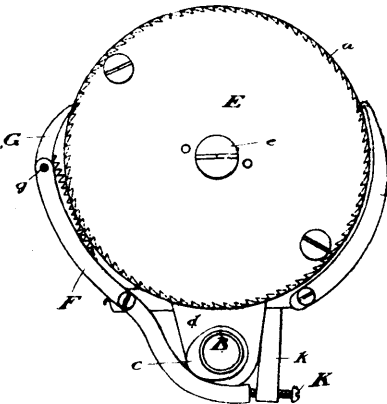
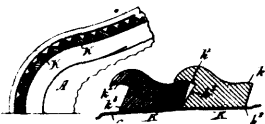

27079 Kitson's Counter to Register Shaft Revolutions.

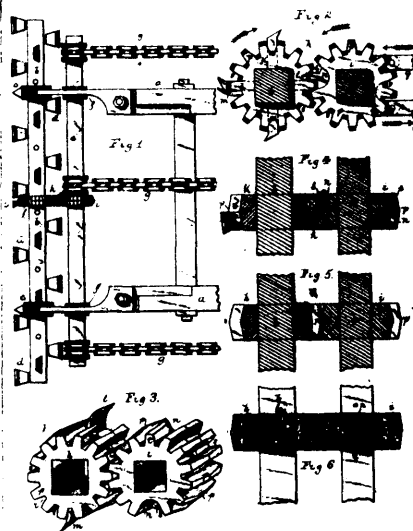

27080 Stine's Mining Machine.

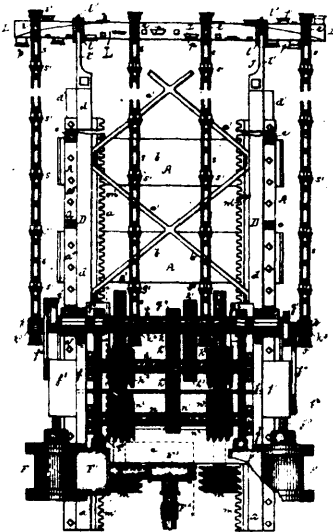

27081 Stine & Smith's mining Machine

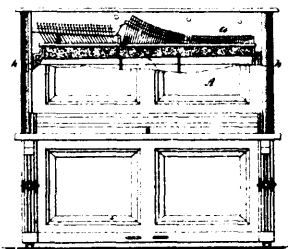

27082 Gmehlin's Mute Bar Damper for Upright Flaros.

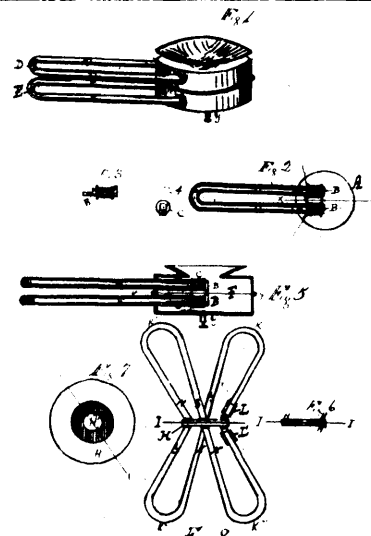
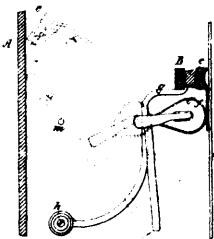

27083 Trueman & Bliss' Art of Telephony.

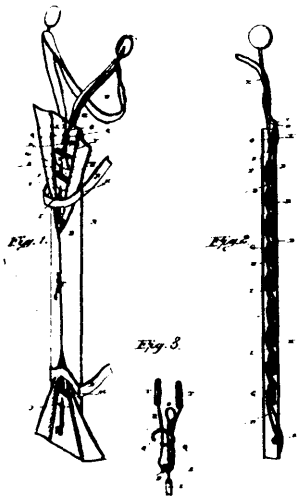

27084 Woodward's Electric Belt.

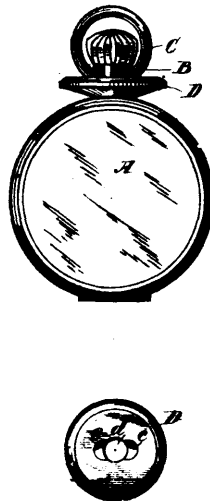

27085 Watts' Safe Guard for Watches.

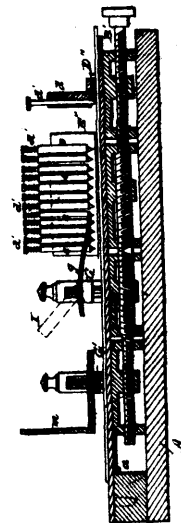

27086 Adler's Apparatus for Grading Shoe Soles and Uppers, etc.

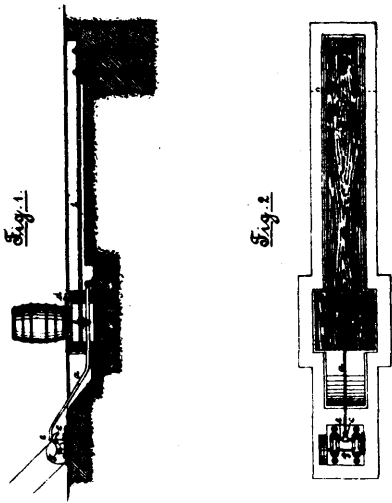

27087 Heylgenstaedt's Machine for Packing Tubs, Casks and Barrels.

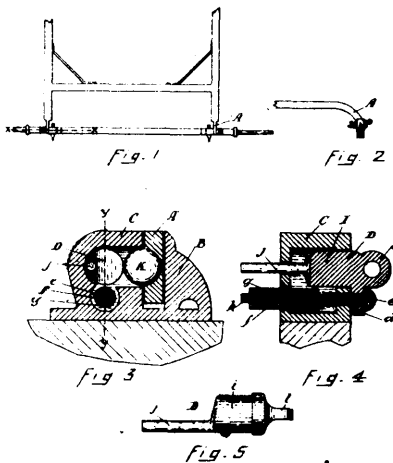

27088 Hanson's Carriage Shaft Coupling.

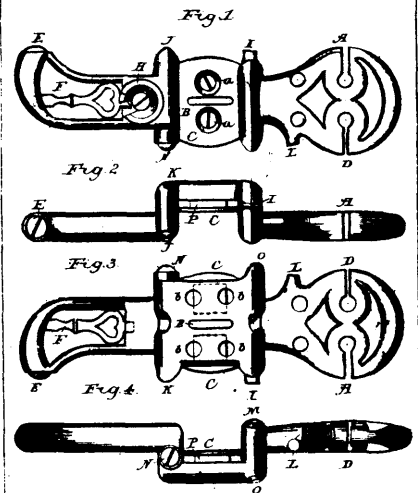

27089 Lalonde's Saw Set, Gauge and Baker Guide.

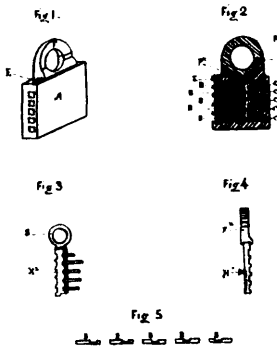

27090 Jenks' Padlock.

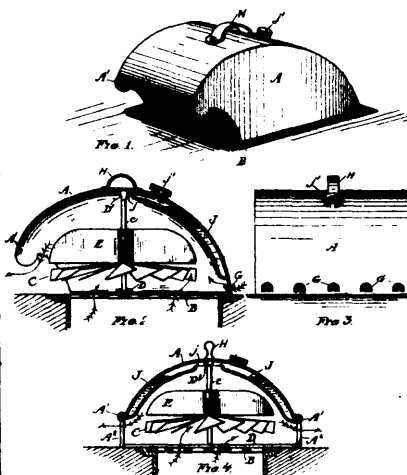

27091 Klein's Heat Deflector for Registers

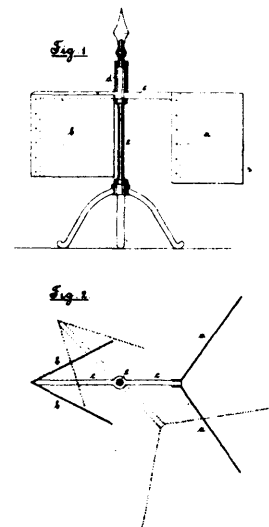

27092 Schaufuss' Double Flys for Weathercocks, etc.