

CANADIAN SOCIETY OF CIVIL ENGINEERS
STANDARD SPECIFICATIONS

FOR

Cast Iron Water Pipe and Special
Castings

With Tables of Dimensions,
Thicknesses and Weights

AS PRESENTED BY A

SPECIAL COMMITTEE

APPOINTED AT THE

Annual Meeting of the Society

HELD IN

OTTAWA, Ont.

January, 1910.

Approved by the Council of the Society, June 11th, 1910

CANADIAN SOCIETY OF CIVIL ENGINEERS
STANDARD SPECIFICATIONS

FOR

Cast Iron Water Pipe and Special
Castings

With Tables of Dimensions,
Thicknesses and Weights

AS PRESENTED BY A

SPECIAL COMMITTEE

APPOINTED AT THE

Annual Meeting of the Society

HELD IN

OTTAWA, Ont.

January, 1910.

Approved by the Council of the Society, June 11th, 1910

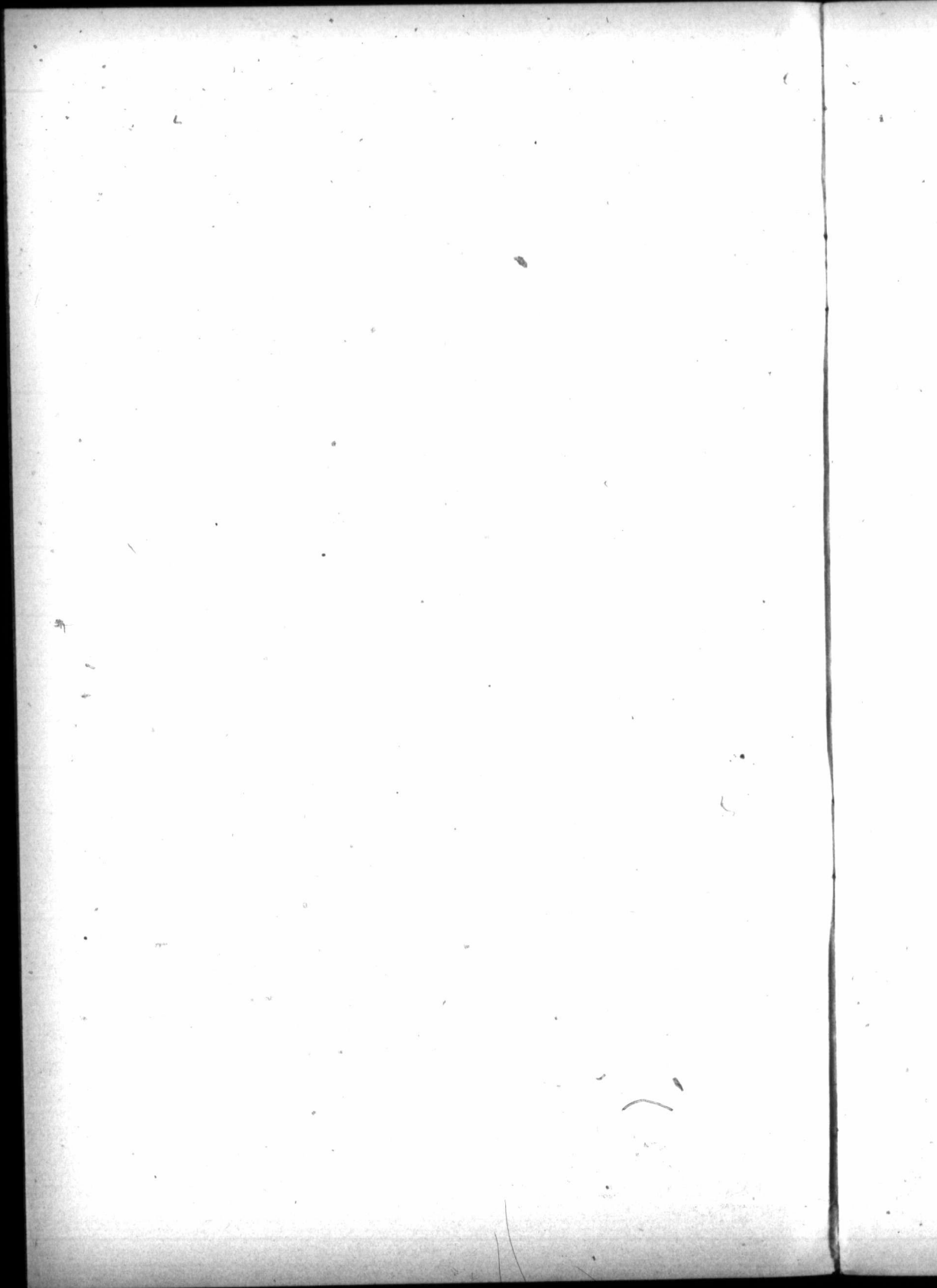

REPORT OF THE COMMITTEE OF THE STANDARDIZATION
OF THE SPECIFICATIONS FOR CAST IRON PIPE
AND SPECIAL CASTINGS.

*To the President and Council of the Canadian Society of Civil
Engineers.*

GENTLEMEN,

Nearly every Canadian engineer at some time or other has had work under his charge on which it was necessary to use cast iron water pipe and, no doubt, he has been confronted with the fact that in Canada we have no recognized standard of cast iron water pipe specifications. The result has been that, in most cases, the engineers, when ordering this class of material, have drawn up their own specifications and plans for the pipe and have then called for tenders from the different foundries. The foundry starts filling the order and then, when the engineer or his inspector visits the plant for the purpose of witnessing the Hydrostatic Test and inspecting the pipe, he finds that the foundry has not recognized the exact dimensions of the pipe in certain respects, such as depth of socket, etc., but has cast the pipe with the patterns they carry in stock. If the engineer himself is on the ground he can easily dispose of the matter in a very few minutes, but if he is represented by an inspector, considerable delay usually follows through correspondence in thrashing the matter out, it usually resulting in the pipes being accepted provided they have stood the Hydrostatic Test. There is no doubt that if a recognized set of specifications, etc., is adopted by this Society, it would be eagerly welcomed by Canadian engineers. The manufacturer would also welcome the same as he then could have his patterns manufactured to cast the adopted sizes and would not be continually bothered by checking up the varied specifications which are submitted to him.

In brief, the engineer would benefit by merely specifying that he wished tenders on so many lengths of a certain size of cast iron pipe as per Canadian Society Civil Engineers' specifications.

The manufacturer would benefit as he would be able to work to definite standards and, in slack times, he could manufacture and stock his pipe which, in turn, would be equally advantageous to the engineer or municipality desiring pipes, as the pipe would then be on hand to ship from stock. As it is at the present time, the manufacturers are very loath to stock up pipe as very often the engineer desires to have certain changes made in the shape. On the other side of the line there are several recognized standards, such as the American Water Works Association, the New England Water Works Association, and the American Society for Testing Materials, but in

Canada we have no such recognized standards, and the result has been that the manufacturers have accumulated a great variety of patterns.

We, your Committee, having carefully considered the question, beg leave to submit the attached specifications and would recommend that they be adopted as the standard for Canada by the Canadian Society of Civil Engineers.

All of which is respectfully submitted.

(Signed)

NEWTON J. KER, Chairman.
T. C. IRVING, Jr.
OWEN W. SMITH.
R. S. LEA.
E. A. JAMES.

June 1st, 1910.

CANADIAN SOCIETY OF CIVIL ENGINEERS STANDARD
SPECIFICATIONS FOR CAST IRON PIPE AND
SPECIAL CASTINGS.

DESCRIPTION OF PIPES.

Section 1. The pipes shall be made with hub and spigot joints, and shall accurately conform to the dimensions given in Tables Nos. 1 and 2. They shall be straight and shall be true circles in section, with their inner and outer surfaces concentric, and shall be of the specified dimensions in outside diameter. They shall be at least 12 feet in length, exclusive of socket.

Pipes with thickness and weight intermediate between the classes in Table No. 2 shall be made of the same outside diameter as the next heavier class. Pipes with thickness and weight less than shown by Table No. 2 shall be made of the same outside diameter as the Class A pipe; and pipes with thickness and weight more than shown by Table No. 2 shall be made of the same outside diameter as the Class D pipe.

All pipes having the same outside diameter shall have the same inside diameter at both ends. The inside diameter of the lighter pipes of each standard outside diameter shall be gradually increased for a distance of about 6 inches from each end of the pipe so as to obtain the required standard thickness and weight for each size and class of pipe.

For pipes of each size from 4-inch to 24-inch inclusive, there shall be two standards of outside diameter, and for pipes from 30-inch to 60-inch inclusive, there shall be four standards of outside diameter, as shown by Table No. 1. The nominal diameters to be cast on pipes above 4-inch.

For pipes 4-inch to 12-inch inclusive, one class of special castings shall be furnished, made from Class D pattern. Those having spigot ends shall have outside diameters of spigot ends midway between the two standards of outside diameter as shown by Table No. 1, and shall be tapered back for a distance of 6 inches.

For pipes from 14-inch to 24-inch inclusive, two classes of special castings shall be furnished; Class B special castings with Classes A and B pipes, and Class D special castings with Classes C and D pipes; the former shall have cast on them the letters "AB" and the latter "CD." For pipes 30-inch to 60-inch inclusive, four classes of special castings shall be furnished, one for each class of pipe, and shall have cast on them the letter of the class to which they belong.

ALLOWABLE VARIATION IN DIAMETER OF PIPES AND SOCKETS.

Section 2. Especial care shall be taken to have the sockets of the required size. The sockets and spigots will be tested by circular gauges, and no pipe will be received which is defective in joint room from any cause. The diameters of the sockets and the outside diameters of the spigot ends of the pipes shall not vary from the standard dimensions by more than .06 of an inch for pipes 16 inches or less in diameter; .08 of an inch for 18-inch, 20-inch and 24-inch pipes; .10 of an inch for 30-inch, 36-inch and 42-inch pipes; .12 of an inch for 48-inch, and .15 of an inch for 54-inch and 60-inch pipes.

ALLOWABLE VARIATION IN THICKNESS.

Section 3. For pipes whose standard thickness is less than 1 inch, the thickness of metal in the body of the pipe shall not be more than .08 of an inch less than the standard thickness, and for pipes whose standard thickness is 1 inch or more, the variation shall not exceed .10 of an inch, except that for spaces not exceeding 8 inches in length in any direction, variations from the standard thickness of .02 of an inch in excess of the allowance above given shall be permitted.

For special castings of standard patterns a variation of 50 per cent. greater than allowed for straight pipes shall be permitted.

DEFECTIVE SPIGOTS MAY BE CUT.

Section 4. Defective Spigot ends on pipes 12 inches or more in diameter may be cut off in a lathe and a half-round wrought-iron band shrunk into a groove cut in the end of the pipe. Not more than 12 per cent. of the total number of accepted pipes of each size shall be cut and banded, and no pipe shall be banded which is less than 11 feet in length, exclusive of the socket.

In case the length of a pipe differs from 12 feet, the standard weight of the pipe given in Table No. 2 shall be modified in accordance therewith.

SPECIAL CASTINGS.

Section 5. All special castings shall be made in accordance with the cuts and the dimensions given in the tables forming a part of these specifications.

The diameters of the sockets and the external diameters of the spigot ends of the special castings shall not vary from the standard dimensions by more than .12 of an inch for castings 16 inches or less in diameter; .15 of an inch for 18-inch, 20-inch and 24-inch; .20 of an inch for 30-inch, 36-inch and 42-inch, and .24 of an inch for 48-inch, 54-inch and 60-inch. These variations apply only to special castings made from standard patterns.

The flanges on all manhole castings and manhole covers shall be faced true and smooth, and drilled to receive bolts of the sizes given in the tables. The manufacturer shall furnish and deliver all bolts for bolting on the manhole covers, the bolts to be of the sizes shown on plans and made of the best quality of mild steel, with hexagonal heads and nuts and sound, well-fitting threads.

MARKING.

Section 6. Every pipe and special casting shall have distinctly cast upon it the initials of the maker's name. When cast especially to order, each pipe larger than 4-inch may also have cast upon it figures showing the year in which it was cast and a number signifying the order in point of time in which it was cast, the figures denoting the year being above and the number below, thus:

1908	1908	1908
1	2	3

etc., also any initials, not exceeding four, which may be required by the purchaser. The letters and figures shall be cast on the outside and shall not be less than 2 inches in length and $\frac{1}{4}$ of an inch in relief for pipes 8 inches in diameter and larger. For smaller sizes of pipes the letters may be 1 inch in length. The weight and the class letter shall be conspicuously painted in white on the inside of each pipe and special casting, after the coating has become hard.

ALLOWABLE PERCENTAGE OF VARIATION IN WEIGHT.

Section 7. No pipe shall be accepted the weight of which shall be less than the standard weight by more than 5 per cent for pipes 16 inches or less in diameter, and 4 per cent for pipes more than 16 inches in diameter, and no excess above the standard weight of more than the given percentage for the several sizes shall be paid for. The total weight to be paid for shall not exceed for each size and class of pipe received the sum of the standard weights of the same number of pieces of the given size and class by more than 2 per cent.

No special casting shall be accepted the weight of which shall be less than the standard weight by more than 10 per cent for pipes 12 inches or less in diameter, and 8 per cent for larger sizes, except that curves, Y pieces and breeches pipe may be 12 per cent below the standard weight, and no excess above the standard weight of more than the above percentages for the several sizes will be paid for. These variations apply only to castings made from the standard patterns.

QUALITY OF IRON.

Section 8. All pipes and special castings shall be made of cast iron of good quality, and of such character as shall make the metal

of the castings strong, tough, and of even grain, and soft enough to satisfactorily admit of drilling and cutting. The metal shall be made without any admixture of cinder iron or other inferior metal, and shall be remelted in a cupola or air furnace.

The contractor shall have the right to make and break three bars from each heat or run of metal, and the test shall be based upon the average results of the three bars. Should the dimensions of the three bars differ from those given below, a proper allowance therefor shall be made in the results of the tests.

TESTS OF MATERIAL.

*Section 9. Specimen bars of the metal used, each being twenty-six inches long by two inches wide and one inch thick, shall be made without charge as often as the engineer may direct, and in default of definite instructions, the contractor shall make and test at least one bar from each heat or run of metal. The bars when placed flatwise upon supports twenty-four inches apart, and loaded in the centre, shall support a load of 1,900 pounds, and show a deflection of not less than .30 of an inch before breaking; or if preferred, tensile bars shall be made which will show a breaking point of not less than 19,000 pounds per square inch.

CASTING OF PIPE.

Section 10. The straight pipes shall be cast in dry sand moulds in a vertical position. Pipes 16 inches or less in diameter shall be cast with the hub end up or down, as specified in the proposals. Pipes 18 inches or more in diameter shall be cast with the hub end down.

The pipes shall not be stripped or taken from the pit while showing colour of heat, but shall be left in the flasks for a sufficient length of time to prevent unequal contraction by subsequent exposure.

QUALITY OF CASTINGS.

Section 11. The pipes and special castings shall be smooth, free from scales, lumps, blisters, sand holes, and defects of every nature which unfit them for the use for which they are intended. No plugging or filling will be allowed.

CLEANING AND INSPECTION.

Section 12. All pipes and special castings shall be thoroughly cleaned and subjected to a careful hammer inspection. No casting shall be coated unless entirely clean and free from rust, and approved in these respects immediately before being dipped, by the engineer.

* Pipe may be made under higher metal tests when desired.
Stock pipe may be made under metal tests as low as 1,800 pounds.

COATING.

Section 13. Every pipe and special casting shall be coated inside and out with coal-tar pitch varnish. The varnish shall be made from coal tar. To this material sufficient oil shall be added to make a smooth coating, tough and tenacious when cold, and not brittle nor with any tendency to scale off.

Each casting shall be heated to a temperature of 300 degrees Fahrenheit immediately before it is dipped, and shall have not less than this temperature at the time it is put in the vat. The ovens in which the pipes are heated shall be so arranged that all portions of the pipe shall be heated to an even temperature. Each casting shall remain in the bath at least five minutes.

The varnish shall be heated to a temperature of 300 degrees Fahrenheit (or less if the engineer shall so order), and shall be maintained at this temperature during the time the casting is immersed.

Fresh pitch and oil shall be added when necessary to keep the mixture at the proper consistency, and the vat shall be emptied of its contents and refilled with fresh pitch when deemed necessary by the engineer. After being coated the pipe shall be carefully drained of the surplus varnish. Any pipe or special casting that is to be recoated shall first be thoroughly scraped and cleaned.

HYDROSTATIC TEST.

Section 14. When the coating has become hard, the straight pipes shall be subjected to a proof by hydrostatic pressure, and, if required by the engineer, they shall also be subjected to a hammer test under this pressure.

The pressure to which the different sizes and classes of pipes shall be subjected are as follows:

	20-Inch Diameter and Larger Pounds per Square Inch	Less than 20-Inch Diameter Pounds per Square Inch
Class A Pipe	150	300
Class B Pipe	200	300
Class C Pipe	250	300
Class D Pipe	300	300

WEIGHING.

Section 15. The pipes and special castings shall be weighed for payment under the supervision of the engineer after the application of the coal-tar pitch varnish. If desired by the engineer, the pipes and special castings shall be weighed after their delivery, and the

weights so ascertained shall be used in the final settlement, provided such weighing is done by a legalized weighmaster. Bids shall be submitted and a final settlement made upon the basis of a ton of 2,000 pounds.

CONTRACTOR TO FURNISH MEN AND MATERIALS.

Section 16. The contractor shall provide all tools, testing machines, materials, and men necessary for the required testing, inspection, and weighing at the foundry of the pipe and special castings; and should the purchaser have no inspector at the works, the contractor shall, if required by the engineer, furnish a sworn statement that all of the tests have been made as specified, this statement to contain the results of the tests upon the test bars.

POWER OF ENGINEER TO INSPECT.

Section 17. The engineer shall be at liberty at all times to inspect the material at the foundry, and the moulding, casting, and coating of the pipes and special castings. The forms, sizes, uniformity, and condition of all pipes and other castings herein referred to shall be subject to his inspection and approval, and he may reject, without proving, any pipe or other casting which, in his opinion, is not in conformity with the specifications or drawings.

INSPECTOR TO REPORT.

Section 18. The inspector at the foundry shall report daily to the foundry office all pipes and special castings rejected, with the causes for rejection.

CASTINGS TO BE DELIVERED SOUND AND PERFECT.

Section 19. All the pipes and other castings must be delivered in all respects sound and conformable to these specifications. The inspection shall not relieve the contractor of any of his obligations in this respect, and any defective pipes or other castings which may have passed the engineer at the works or elsewhere shall be at all times liable to rejection when discovered, until the final completion and adjustment of the contract; provided, however, that the contractor shall not be held liable for pipes or special castings found to be cracked after they have been accepted at the agreed point of delivery. Care shall be taken in handling the pipes not to injure the coating, and no pipes or other material of any kind shall be placed in the pipes during transportation or at any time after they have received the coating.

DEFINITION OF THE WORD "ENGINEER."

Section 20. Wherever the word "engineer" is used herein it shall be understood to refer to the engineer or inspector acting for the purchaser and to his properly authorized agents, limited by the particular duties intrusted to them.

**CANADIAN SOCIETY OF CIVIL ENGINEERS
STANDARD DIMENSIONS OF PIPE**

Table No. 1

Classes A, B, C, D

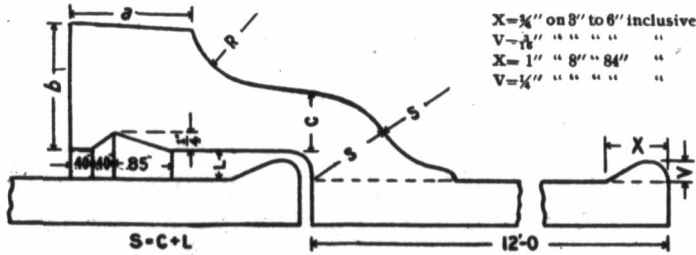

Nominal Diam. Inches	Classes	Actual Outside Diam. Inches	Diam. of Sockets		Depth of Sockets		A	B	C
			Pipe Inches	Special Castings Inches	Pipe Inches	Special Castings Inches			
4	A	4.80	5.60	5.70	3.50	4.00	1.5	1.30	.85
4	B-C-D	5.00	5.90	5.70	3.50	4.00	1.5	1.30	.85
6	A	6.90	7.70	7.80	3.50	4.00	1.5	1.40	.70
6	B-C-D	7.10	7.90	7.80	3.50	4.00	1.5	1.40	.70
8	A-B	9.05	9.85	10.00	4.00	4.00	1.5	1.50	.75
8	C-D	9.90	10.10	10.00	4.00	4.00	1.5	1.50	.75
10	A-B	11.10	11.90	12.10	4.00	4.00	1.5	1.50	.75
10	C-D	11.40	12.20	12.10	4.00	4.00	1.5	1.40	.80
12	A-B	13.20	14.00	14.20	4.00	4.00	1.5	1.60	.80
12	C-D	13.50	14.30	14.20	4.00	4.00	1.5	1.70	.85
14	A-B	15.30	16.10	16.10	4.00	4.00	1.5	1.70	.85
14	C-D	15.65	16.45	16.45	4.00	4.00	1.5	1.80	.90
16	A-B	17.40	18.40	18.40	4.00	4.00	1.75	1.80	.90
16	C-D	17.80	18.80	18.90	4.00	4.00	1.75	1.90	1.00
18	A-B	19.50	20.50	20.50	4.00	4.00	1.75	1.90	.95
18	C-D	19.92	20.92	20.92	4.00	4.00	1.75	2.10	1.05
20	A-B	21.60	22.60	22.60	4.00	4.00	1.75	2.00	1.00
20	C-D	22.08	23.08	23.08	4.00	4.00	1.75	2.30	1.15
24	A-B	25.80	26.80	26.80	4.00	4.00	2.00	2.10	1.05
24	C-D	26.32	27.32	27.32	4.00	4.00	2.00	2.50	1.25
30	A	31.74	32.74	32.74	4.50	4.50	2.00	2.50	1.15
30	B	32.00	33.00	33.00	4.50	4.50	2.00	2.30	1.15
30	C	32.40	33.40	33.40	4.50	4.50	2.00	2.60	1.32
30	D	32.74	33.74	33.74	4.50	4.50	2.00	3.00	1.50
36	A	37.96	38.96	38.96	4.50	4.50	2.00	2.50	1.25
36	B	38.30	39.30	39.30	4.50	4.50	2.00	2.50	1.40
36	C	38.70	39.70	39.70	4.50	4.50	2.00	3.10	1.60
36	D	39.16	40.16	40.16	4.50	4.50	2.00	3.40	1.80
42	A	44.20	45.20	45.20	5.00	5.00	2.00	2.80	1.40
42	B	44.50	45.50	45.50	5.00	5.00	2.00	3.00	1.50
42	C	45.10	46.10	46.10	5.00	5.00	2.00	3.40	1.75
42	D	45.58	46.58	46.58	5.00	5.00	2.00	3.80	1.95
48	A	50.50	51.50	51.50	5.00	5.00	2.00	3.00	1.50
48	B	50.90	51.90	51.90	5.00	5.00	2.00	3.30	1.65
48	C	51.40	52.40	52.40	5.00	5.00	2.00	3.90	1.95
48	D	51.98	52.98	52.98	5.00	5.00	2.00	4.20	2.20
54	A	56.66	57.66	57.66	5.50	5.50	2.25	3.20	1.60
54	B	57.10	58.10	58.10	5.50	5.50	2.25	3.60	1.80
54	C	57.60	58.60	58.60	5.50	5.50	2.25	4.00	2.15
54	D	58.40	59.40	59.40	5.50	5.50	2.25	4.40	2.45
60	A	62.60	63.60	63.60	5.50	5.50	2.25	3.40	1.70
60	B	63.40	64.40	64.40	5.50	5.50	2.25	3.70	1.90
60	C	64.20	65.20	65.20	5.50	5.50	2.25	4.20	2.25
60	D	64.82	65.82	65.82	5.50	5.50	2.25	4.70	2.60
72	A	75.34	76.34	76.34	5.50	5.50	2.25	3.50	1.87
72	B	76.00	77.00	77.00	5.50	5.50	2.25	4.20	2.20
72	C	76.86	77.86	77.86	5.50	5.50	2.25	4.60	2.94
84	A	87.54	88.54	88.54	5.50	5.50	2.50	4.10	2.10
84	B	88.54	89.54	89.54	5.50	5.50	2.50	4.50	2.60

**CANADIAN SOCIETY OF CIVIL ENGINEERS
STANDARD THICKNESS AND WEIGHTS OF CAST IRON PIPE**

Table No. 2 Classes A, B, C, D

Nominal Diameter Inches	CLASS A 100-Feet Head 43 Pounds Pressure			CLASS B 200-Feet Head 86 Pounds Pressure			CLASS C 300-Feet Head 129 Pounds Pressure			CLASS D 400-Feet Head 172 Pounds Pressure			Nominal Diameter Inches
	Thick- ness Inches	Weight per		Thick- ness Inches	Weight per		Thick- ness Inches	Weight per		Thick- ness Inches	Weight per		
		Foot	Length		Foot	Length		Foot	Length		Foot	Length	
4	.42	20.0	210	.45	21.7	260	.48	23.3	280	.52	25.0	300	4
6	.54	27.0	270	.57	29.7	350	.60	32.3	380	.63	35.0	400	6
8	.66	42.0	515	.69	47.5	570	.72	52.1	625	.75	56.8	680	8
10	.80	57.1	685	.83	63.8	765	.86	70.3	850	.89	76.7	920	10
12	.94	72.5	870	.97	82.1	985	1.00	91.7	1100	1.03	100.0	1200	12
14	1.08	92.5	1070	1.11	102.0	1220	1.14	112.5	1350	1.17	123.0	1500	14
16	1.22	108.3	1300	1.25	122.0	1500	1.28	142.8	1700	1.31	153.2	1900	16
18	1.36	129.2	1550	1.39	150.0	1800	1.42	175.0	2100	1.45	191.7	2300	18
20	1.50	150.0	1800	1.53	175.0	2100	1.56	208.3	2500	1.59	229.2	2750	20
24	1.76	204.8	2450	1.79	232.3	2800	1.82	270.0	3200	1.85	306.7	3600	24
30	2.08	291.7	3500	2.11	332.3	4000	2.14	400.0	4500	2.17	466.7	5000	30
36	2.40	391.7	4700	2.43	434.3	5400	2.46	515.0	6000	2.49	585.0	6700	36
42	2.72	512.5	6150	2.75	591.7	7100	2.78	716.7	8000	2.81	826.0	9000	42
48	3.04	666.1	8000	3.07	750.0	9000	3.10	868.3	10000	3.13	1000.0	11000	48
54	3.36	800.0	9500	3.39	923.3	11000	3.42	1141.7	13000	3.45	1341.7	15000	54
60	3.68	916.7	11000	3.71	1104.3	12500	3.74	1341.7	15000	3.77	1563.3	17000	60
66	4.00	1283.4	15400	4.03	1513.8	18000	4.06	1800.0	20500	4.09	2104.3	23000	66
72	4.32	1650.0	19800	4.35	1920.0	22500	4.38	2250.0	25500	4.41	2625.0	29000	72
78	4.64	2016.7	24200	4.67	2323.3	27000	4.70	2700.0	30500	4.73	3100.0	34500	78
84	4.96	2383.4	28600	4.99	2700.0	31500	5.02	3100.0	35500	5.05	3525.0	40000	84

The above weights are per length to lay 12 feet, including standard sockets; proportionate allowance to be made for any variation

**CANADIAN SOCIETY OF CIVIL ENGINEERS
STANDARD DIMENSIONS OF PIPE**

High Pressure Service

Table No. 3

Classes E, F, G, H

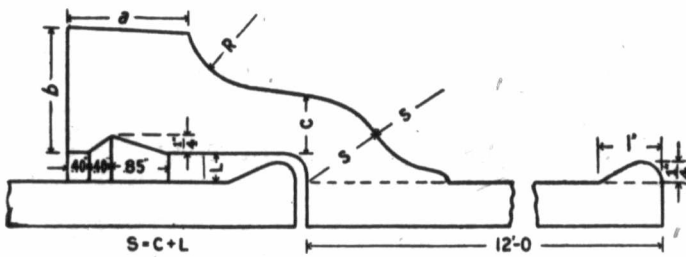

Nominal Diam. Inches	Classes	Actual Outside Diam. Inches	Diam. of Sockets	Depth of Sockets	A	B	C	R	Nominal Diam. Inches
			Pipe and Specials	Pipe and Specials					
6	E-F	7.22	8.02	4.00	1.50	1.75	.75	1.10	6
6	G-H	7.38	8.18	4.00	1.50	1.85	.85	1.10	6
8	F-F	9.42	10.22	4.00	1.50	1.85	.85	1.10	8
8	G-H	9.60	10.40	4.00	1.50	1.95	.95	1.10	8
10	E-F	11.60	12.40	4.50	1.75	1.95	.95	1.10	10
10	G-H	11.84	12.64	4.50	1.75	2.05	1.05	1.10	10
12	E-F	13.78	14.58	4.50	1.75	2.05	1.05	1.10	12
12	G-H	14.08	14.88	4.50	1.75	2.20	1.20	1.10	12
14	E-F	15.98	16.78	4.50	2.00	2.15	1.15	1.10	14
14	G-H	16.32	17.12	4.50	2.00	2.35	1.35	1.10	14
16	E-F	18.16	18.96	4.50	2.00	2.30	1.25	1.15	16
16	G-H	18.54	19.34	4.50	2.00	2.55	1.45	1.15	16
18	E-F	20.34	21.14	4.50	2.25	2.45	1.40	1.15	18
18	G-H	20.78	21.58	4.50	2.25	2.75	1.65	1.15	18
20	E-F	22.54	23.34	4.50	2.25	2.55	1.50	1.15	20
20	G-H	23.02	23.82	4.50	2.25	2.85	1.75	1.20	20
24	E-F	26.90	27.90	5.00	2.25	2.85	1.70	1.20	24
30	E	33.10	34.10	5.00	2.25	3.25	1.80	1.50	30
30	F	33.46	34.46	5.00	2.25	3.50	2.00	1.55	30
36	E	39.60	40.60	5.00	2.25	3.70	2.05	1.70	36
36	F	40.04	41.04	5.00	2.25	4.00	2.30	1.80	36

**CANADIAN SOCIETY OF CIVIL ENGINEERS
STANDARD THICKNESS AND WEIGHTS OF CAST IRON PIPE**

For Fire Lines and Other High Pressure Service

Classes E, F, G, H

Table No. 4

Nominal Inside Diameter Inches	CLASS E 500-Feet Head 217 Pounds Pressure			CLASS F 600-Feet Head 240 Pounds Pressure			CLASS G 700-Feet Head 340 Pounds Pressure			CLASS H 900-Feet Head 347 Pounds Pressure		
	Thick- ness Inches	Weight per		Thick- ness Inches	Weight per		Thick- ness Inches	Weight per		Thick- ness Inches	Weight per	
		Foot	Length		Foot	Length		Foot	Length		Foot	Length
6	.58	41.7	500	.61	43.2	520	.65	47.1	565	.69	49.6	595
8	.66	41.7	740	.71	63.7	790	.75	70.8	850	.80	75.0	900
10	.74	86.3	1035	.80	92.1	1105	.86	100.9	1210	.92	106.7	1290
12	.82	113.8	1365	.89	122.1	1465	.97	135.4	1625	1.04	143.8	1725
14	.90	145.0	1740	.99	157.5	1800	1.07	174.2	2080	1.16	186.7	2240
16	1.09	210.6	2155	1.08	196.4	2240	1.28	247.1	2510	1.37	256.7	2640
18	1.17	257.6	2440	1.27	286.3	2435	1.39	320.8	3205	1.51	344.5	3440
20	1.15	263.0	3155						3850			4135
24	1.31	359.6	4315	1.45	392.9	4715						
30	1.55	621.7	6260	1.72	565.4	7025						
36	1.80	725.0	8700	2.02	820.0	9540						

The above weights are per length to lay 12 feet, including standard sockets; proportionate allowance to be made for any variation.

For HIGH PRESSURE PIPE from 6 inches to 24 inches inclusive, one class of special castings shall be furnished for Classes E and F pipe, and one class of special castings for Classes G and H pipe. For 36-inch and 36-inch pipe, one class of special castings shall be furnished for each class of pipe.

**CANADIAN SOCIETY OF CIVIL ENGINEERS:
STANDARD LUGS**

Number and Weights of Lugs on Outlets of Different Sizes

Table No. 5

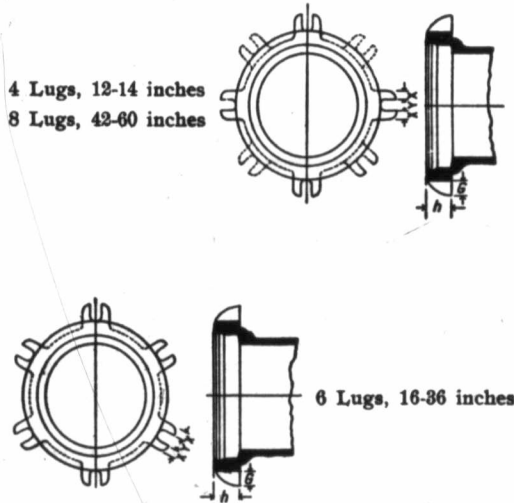

Nominal Diameter Outlet Inches	Number of Pairs of Lugs	Approximate Weight Lugs on One Bell Pounds	Nominal Diameter Outlet Inches	Number of Pairs of Lugs	Approximate Weight Lugs on One Bell Pounds
12	4	32	30	6	80
14	4	32	36	6	80
16	6	56	42	8	111
18	6	56	48	8	114
20	6	56	54	8	134
24	6	56	60	8	137

Two pairs of lugs are placed on the vertical axis of each bell, the others at equal distances around circumference. H is equal depth of bell on all sizes.

G equals 2.50 inches, X equals 1.25 inches, Y equals 1.63 inches for 12 to 24 inches inclusive.

G equals 3.00 inches, X equals 1.50 inches, Y equals 2.00 inches for 30 to 60 inches inclusive.

**CANADIAN SOCIETY OF CIVIL ENGINEERS
STANDARD SPECIAL CASTINGS FOR WATER
Standard Curves, Bell and Spigot, 1/4, 1/8, 1/16**

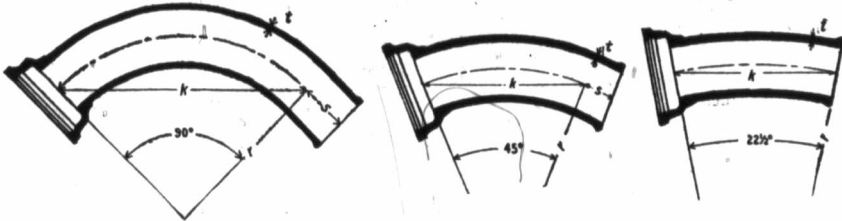

TABLE No. 6

TABLE No. 7

Nominal Diam., In.	Class	1/4 Curves			Approx. Weight Pounds	Nominal Diam., In.	Class	1/8 Curves			Approx. Weight Pounds	1/16 Curves		Approx. Weight Pounds
		t	r	k				t	r	k		r	k	
4	D	.52	16	22.60	82	4	D	.52	24	18.40	66	48	18.70	66
6	D	.55	16	22.60	130	6	D	.55	24	18.40	105	48	18.70	105
8	D	.60	16	22.60	200	8	D	.60	24	18.40	150	48	18.70	150
10	D	.68	16	22.60	278	10	D	.68	24	18.40	202	48	18.70	202
12	D	.75	16	22.60	366	12	D	.75	24	18.40	265	48	18.70	265
14	B	.66	18	25.50	406	14	B	.66	36	27.60	359	72	28.10	312
14	D	.82	18	25.50	504	14	D	.82	36	27.60	442	72	28.10	382
16	B	.70	24	34.00	594	16	B	.70	36	27.60	445	72	28.10	388
16	D	.89	24	34.00	750	16	D	.89	36	27.60	558	72	28.10	484
18	B	.75	24	34.00	710	18	B	.75	36	27.60	583	72	28.10	464
18	D	.96	24	34.00	888	18	D	.96	36	27.60	663	72	28.10	574
20	B	.80	24	34.00	840	20	B	.80	48	36.70	758	96	37.50	676
20	D	1.03	24	34.00	1070	20	D	1.03	48	36.70	964	96	37.50	858
24	B	.89	30	42.40	1290	24	B	.89	60	45.90	1181	120	46.80	1072
24	D	1.16	30	42.40	1656	24	D	1.16	60	45.90	1515	120	46.80	1372
30	A	.88	36	50.90	1814	30	A	.88	60	45.90	1475	120	46.80	1342
30	B	1.03	36	50.90	2082	30	B	1.03	60	45.90	1684	120	46.80	1528
30	C	1.20	36	50.90	2454	30	C	1.20	60	45.90	1983	120	46.80	1800
30	D	1.37	36	50.90	2836	30	D	1.37	60	45.90	2291	120	46.80	2080
36	A	.99	48	67.90	2964	36	A	.99	90	68.90	2472	180	70.20	2472
36	B	1.15	48	67.90	3500	36	B	1.15	90	68.90	2916	180	70.20	2916
36	C	1.36	48	67.90	4120	36	C	1.36	90	68.90	3430	180	70.20	3430
36	D	1.58	48	67.90	4820	36	D	1.58	90	68.90	4012	180	70.20	4012
						42	A	1.10	90	68.90	3286	180	70.20	3286
						42	B	1.28	90	68.90	3778	180	70.20	3778
						42	C	1.54	90	68.90	4600	180	70.20	4600
						42	D	1.78	90	68.90	5360	180	70.20	5360
						48	A	1.26	90	68.90	4230	180	70.20	4230
						48	B	1.42	90	68.90	4820	180	70.20	4820
						48	C	1.71	90	68.90	5796	180	70.20	5796
						48	D	1.96	90	68.90	6750	180	70.20	6750
						54	A	1.35	90	68.90	5180	180	70.20	5180
						54	B	1.55	90	68.90	5990	180	70.20	5990
						54	C	1.90	90	68.90	7330	180	70.20	7330
						54	D	2.23	90	68.90	8620	180	70.20	8620
						60	A	1.39	90	68.90	5990	180	70.20	5990
						60	B	1.67	90	68.90	7130	180	70.20	7130
						60	C	2.00	90	68.90	8590	180	70.20	8590
						60	D	2.38	90	68.90	10240	180	70.20	10240

S=8 inches on sizes 4 and 6 inches. S=6 inches on 1/8 Curves on sizes 4 to 30 inches inclusive.
 S=10 inches on sizes 8 inches. S=8 inches on 1/16 Curves on sizes 4 to 12 inches inclusive.
 S=12 inches on sizes 10 to 36 inches. All weights are approximate.

**CANADIAN SOCIETY OF CIVIL ENGINEERS
STANDARD SPECIAL CASTINGS FOR WATER
Standard Curves, Bell and Spigot—Standard Offsets**

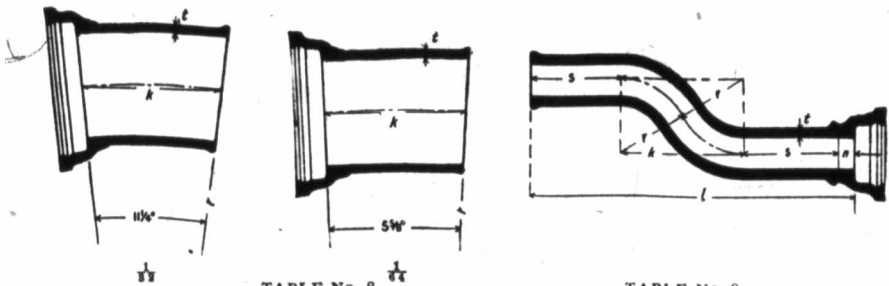

TABLE No. 8

TABLE No. 9

Nominal Diam., in.	Class	Curves			Approx. Weight Pounds	Curves			Nominal Diam., inches	Class	r	l	Approx. Weight Pounds	
		t	r	k		r	k	Approx. Weight Pounds						
4	D	.52	120	23.52	66				4	D	8	35.85	91	
6	D	.55	120	23.52	104				6	D	14	46.25	188	
8	D	.60	120	23.52	150				8	D	15	48.00	280	
10	D	.68	120	23.52	192				10	D	16	49.70	390	
12	D	.75	120	23.52	250				12	D	17	51.45	530	
14	B	.66	180	35.28	364				14	B	18	53.70	555	
14	D	.82	180	35.28	450				14	D	18	53.70	695	
16	B	.70	180	35.28	458				16	B	19	55.40	708	
16	D	.89	180	35.28	570				16	D	19	55.40	900	
18	B	.75	180	35.28	542									
18	D	.96	180	35.28	674									
20	B	.80	240	47.05	808	480	47.10	808						
20	D	1.03	240	47.05	1028	480	47.10	1028						
24	B	.89	240	47.05	1080	480	47.10	1080						
24	D	1.16	240	47.05	1380	480	47.10	1380						
30	A	.88	240	47.05	1350	480	47.10	1350						
30	B	1.03	240	47.05	1540	480	47.10	1540						
30	C	1.20	240	47.05	1810	480	47.10	1810						
30	D	1.37	240	47.05	2090	480	47.10	2090						
36	A	.99	240	47.05	1790	480	47.10	1790						
36	B	1.15	240	47.05	2100	480	47.10	2100						
36	C	1.36	240	47.05	2470	480	47.10	2470						
36	D	1.58	240	47.05	2880	480	47.10	2880						
42	A	1.10	240	47.05	2380	480	47.10	2380						
42	B	1.28	240	47.05	2720	480	47.10	2720	4	D	.52	13.85	10.00	2.00
42	C	1.54	240	47.05	3310	480	47.10	3310	6	D	.55	24.25	10.00	2.00
42	D	1.78	240	47.05	3850	480	47.10	3850	8	D	.60	26.00	10.00	2.00
48	A	1.26	240	47.05	3150	480	47.10	3150	10	D	.68	27.70	10.00	2.00
48	B	1.42	240	47.05	3480	480	47.10	3480	12	D	.75	29.45	10.00	2.00
48	C	1.71	240	47.05	4170	480	47.10	4170	14	B	.66	31.20	10.00	2.50
48	D	1.96	240	47.05	4860	480	47.10	4860	14	D	.82	31.20	10.00	2.50
54	A	1.35	240	47.05	3750	480	47.10	3750	16	B	.70	32.90	10.00	2.50
54	B	1.55	240	47.05	4330	480	47.10	4330	16	D	.89	32.90	10.00	2.50
54	C	1.90	240	47.05	5290	480	47.10	5290						
54	D	2.23	240	47.05	6220	480	47.10	6220						
60	A	1.39	240	47.05	4340	480	47.10	4340						
60	B	1.67	240	47.05	5140	480	47.10	5140						
60	C	2.00	240	47.05	6200	480	47.10	6200						
60	D	2.38	240	47.05	7400	480	47.10	7400						

**CANADIAN SOCIETY OF CIVIL ENGINEERS
STANDARD SPECIAL CASTINGS FOR WATER**

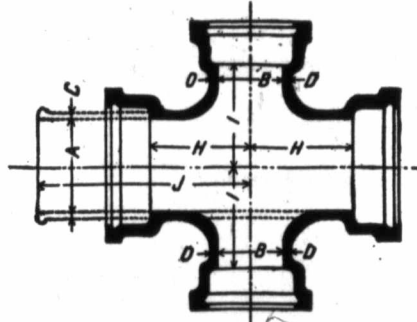

Table No. 10 Standard Branches

Nominal Diam. Inches		Class	Dimensions, Inches			Approximate Weights, Pounds			
A	B		H	J	I	3-Way Branches		4-Way Branches	
						2 Bells	3 Bells	3 Bells	4 Bells
4	3	D	11	23	11	121	120	158	158
4	4	D	11	23	11	125	128	164	166
6	3	D	12	24	12	178	170	207	204
6	4	D	12	24	12	185	188	223	221
6	6	D	12	24	12	203	200	259	257
8	4	D	13	25	13	262	255	301	294
8	6	D	13	25	13	278	270	338	325
8	8	D	13	25	13	301	294	378	372
10	4	D	14	26	14	356	338	395	377
10	6	D	14	26	14	371	352	424	406
10	8	D	14	26	14	389	371	461	448
10	10	D	14	26	14	414	395	511	498
12	4	D	15	27	15	473	445	514	496
12	6	D	15	27	15	496	458	540	512
12	8	D	15	27	15	502	474	573	545
12	10	D	15	27	15	519	491	605	577
12	12	D	15	27	15	540	512	651	628
14	4	B	16	28	16	485	480	585	580
14	4	D	16	28	16	614	588	666	641
14	6	B	16	28	16	500	495	580	555
14	6	D	16	28	16	634	608	730	700
14	8	B	16	28	16	515	510	600	595
14	8	D	16	28	16	662	636	787	761
14	10	B	16	28	16	535	525	635	625
14	10	D	16	28	16	679	653	822	796
14	12	B	16	28	16	560	550	680	670
14	12	D	16	28	16	698	672	860	834
14	14	B	16	28	16	575	569	728	715
14	14	D	16	28	16	750	724	938	968
16	4	B	17	29	17	615	610	675	670

**CANADIAN SOCIETY OF CIVIL ENGINEERS
STANDARD SPECIAL CASTINGS FOR WATER**

Table No. 10—Continued. Standard Branches.

Nominal Diam. Inches		Class	Dimensions, Inches			Approximate Weights, Pounds			
A	B		H	J	I	3-Way Branches		4-Way Branches	
						2 Bells	3 Bells	3 Bells	4 Bells
16	4	D	17	29	17	783	760	864	841
16	6	B	17	29	17	630	625	695	690
16	6	D	17	29	17	802	779	902	879
16	8	B	17	29	17	645	640	730	725
16	8	D	17	29	17	831	808	961	938
16	10	B	17	29	17	660	655	760	755
16	10	D	17	29	17	872	849	1042	1019
16	12	B	17	29	17	685	680	805	800
16	12	D	17	29	17	884	861	1066	1043
16	14	B	17	29	17	695	690	825	820
16	14	D	17	29	17	903	880	1104	1082
16	16	B	17	29	17	729	727	904	901
16	16	D	17	29	17	991	969	1282	1259
18	4	B	18	30	18	755	750	820	815
18	4	D	18	30	18	953	927	1046	1020
18	6	B	18	30	18	765	760	840	835
18	6	D	18	30	18	968	942	1075	1049
18	8	B	18	30	18	780	775	870	865
18	8	D	18	30	18	1000	974	1140	1114
18	10	B	18	30	18	795	790	900	895
18	10	D	18	30	18	1088	1012	1216	1190
18	12	B	18	30	18	815	810	940	935
18	12	D	18	30	18	1075	1049	1290	1264
18	14	B	18	30	18	825	820	955	950
18	14	D	18	30	18	1083	1057	1306	1280
18	16	B	18	30	18	855	850	1020	1015
18	16	D	18	30	18	1108	1082	1356	1330
18	18	B	18	30	18	895	889	1101	1096
18	18	D	18	30	18	1170	1144	1480	1454
20	4	B	19	31	19	923	916	1006	999
20	4	D	19	31	19	1172	1148	1273	1248
20	6	B	19	31	19	930	920	1010	1000
20	6	D	19	31	19	1188	1164	1304	1280
20	8	B	19	31	19	945	935	1035	1025
20	8	D	19	31	19	1212	1188	1352	1328
20	10	B	19	31	19	955	945	1060	1050
20	10	D	19	31	19	1252	1227	1431	1407
20	12	B	19	31	19	975	965	1100	1090
20	12	D	19	31	19	1288	1263	1502	1479
20	14	B	19	31	19	980	970	1110	1100
20	14	D	19	31	19	1342	1318	1613	1588
20	16	B	19	31	19	1010	1000	1170	1160
20	16	D	19	31	19	1347	1323	1622	1597
20	18	B	19	31	19	1085	1025	1225	1215
20	18	D	19	31	19	1365	1341	1658	1634
20	20	B	19	31	19	1077	1070	1314	1307

**CANADIAN SOCIETY OF CIVIL ENGINEERS
STANDARD SPECIAL CASTINGS FOR WATER**

Table No. 10—Continued. Standard Branches

Nominal Diam. Inches		Class	Dimensions, Inches			Approximate Weights, Pounds			
A	B		H	J	I	3-Way Branches		4-Way Branches	
						2 Bells	3 Bells	3 Bells	4 Bells
20	20	D	19	31	19	1463	1488	1852	1828
24	6	B	21	33	21	1809	1289	1425	1405
24	6	D	21	33	21	1670	1637	1809	1775
24	8	B	21	33	21	1823	1808	1453	1433
24	8	D	21	33	21	1697	1664	1863	1830
24	10	B	21	33	21	1841	1821	1489	1469
24	10	D	21	33	21	1732	1699	1933	1900
24	12	B	21	33	21	1862	1842	1582	1511
24	12	D	21	33	21	1768	1735	2005	1972
24	14	B	21	33	21	1402	1381	1609	1589
24	14	D	21	33	21	1810	1777	2088	2055
24	16	B	21	33	21	1448	1423	1694	1673
24	16	D	21	33	21	1858	1825	2185	2151
24	18	B	21	33	21	1460	1440	1727	1706
24	18	D	21	33	21	1885	1852	2238	2205
24	20	B	21	33	21	1474	1454	1756	1736
24	20	D	21	33	21	2025	1991	2518	2484
24	24	B	21	33	21	1528	1503	1854	1834
24	24	D	21	33	21	2146	2113	2727	2694
30	6	A	18	25	24	1272	1300	1407	1434
30	6	B	13	25	24	1433	1417	1580	1563
30	6	C	13	25	24	1693	1673	1870	1850
30	6	D	18	25	24	1984	1920	2113	2099
30	8	A	14	26	24	1318	1346	1453	1481
30	8	B	14	26	24	1482	1466	1624	1609
30	8	C	14	26	24	1765	1745	1953	1934
30	8	D	14	26	24	2004	1990	2182	2168
30	10	A	15	27	24	1369	1396	1512	1540
30	10	B	15	27	24	1538	1521	1685	1668
30	10	C	15	27	24	1857	1837	2075	2056
30	10	D	15	27	24	2108	2094	2319	2306
30	12	A	15	27	24	1395	1420	1555	1580
30	12	B	15	27	24	1555	1540	1715	1700
30	12	C	15	27	24	1911	1891	2184	2164
30	12	D	15	27	24	2154	2140	2411	2398
30	14	A	18	30	26	1547	1575	1787	1764
30	14	B	18	30	26	1805	1789	2085	2069
30	14	C	18	30	26	2159	2140	2497	2477
30	14	D	18	30	26	2567	2553	3026	3013
30	16	A	19	31	26	1648	1675	1805	1832
30	16	B	19	31	26	1899	1883	2200	2184
30	16	C	19	31	26	2272	2253	2662	2642
30	16	D	19	31	26	2692	2678	3206	3192
30	18	A	20	34	26	1757	1741	2024	2007
30	18	B	20	34	26	2044	1976	2387	2318

**CANADIAN SOCIETY OF CIVIL ENGINEERS
STANDARD SPECIAL CASTINGS FOR WATER**

Table No. 10—Continued. Standard Branches

Nominal Diam. Inches		Class	Dimensions, Inches			Approximate Weights, Pounds			
A	B		H	J	I	3-Way Branches		4-Way Branches	
						2 Bells	3 Bells	3 Bells	4 Bells
30	18	C	20	34	26	2484	2353	2862	2781
30	18	D	20	34	26	2805	2791	3361	3348
30	20	A	21	36	26	1857	1818	2157	2118
30	20	B	21	36	26	2182	2088	2584	2490
30	20	C	21	36	26	2667	2555	3237	3126
30	20	D	21	36	26	3041	2921	3657	3598
30	24	A	23	38	26	1079	1940	2312	2274
30	24	B	23	38	26	2318	2219	2742	2648
30	24	C	23	38	26	2847	2736	3474	3362
30	24	D	23	38	26	3290	3170	4014	3895
30	30	A	26	43	26	2212	2129	2602	2520
30	30	B	26	43	26	2599	2453	3106	2960
30	30	C	26	43	26	3310	3137	4110	3937
30	30	D	26	43	26	3850	3660	4799	4609
36	8	A	14	26	27	1751	1777	1938	1963
36	8	B	14	26	27	2055	2073	2268	2287
36	8	C	14	26	27	2421	2433	2679	2691
36	8	D	14	26	27	2780	2780	3038	3039
36	10	A	15	27	27	1810	1835	1996	2021
36	10	B	15	27	27	2128	2147	2345	2364
36	10	C	15	27	27	2534	2546	2822	2834
36	10	D	15	27	27	2903	2902	3188	3188
36	12	A	16	28	27	1884	1909	2084	2109
36	12	B	16	28	27	2219	2288	2458	2477
36	12	C	16	28	27	2644	2656	2962	2973
36	12	D	16	28	27	3032	3033	3349	3350
36	14	A	18	30	29	2039	2065	2279	2304
36	14	B	18	30	29	2415	2433	2709	2728
36	14	C	18	30	29	2872	2883	3251	3263
36	14	D	18	30	29	3470	3470	4033	4033
36	16	A	19	31	29	2135	2160	2410	2436
36	16	B	19	31	29	2521	2540	2853	2872
36	16	C	19	31	29	3003	3014	3431	3442
36	16	D	19	31	29	3618	3617	4231	4230
36	18	A	20	34	29	2279	2246	2581	2548
36	18	B	20	34	29	2701	2650	3073	3022
36	18	C	20	34	29	3206	3136	3673	3604
36	18	D	20	34	29	3852	3755	4506	4409
36	20	A	21	36	29	2409	2346	2752	2689
36	20	B	21	36	29	2885	2800	3336	3251
36	20	C	21	36	29	3537	3426	4212	4101
36	20	D	21	36	29	4050	3905	4757	4612
36	24	A	23	38	29	2451	2513	2844	2907
36	24	B	23	38	29	3099	3014	3624	3539
36	24	C	23	38	29	3806	3695	4585	4474

**CANADIAN SOCIETY OF CIVIL ENGINEERS
STANDARD SPECIAL CASTINGS FOR WATER**

Table No. 10—Continued. Standard Branches

Nominal Diam. Inches		Class	Dimensions, Inches			Approximate Weights, Pounds			
A	B		H	J	I	3-Way Branches		4-Way Branches	
						2 Bells	3 Bells	3 Bells	4 Bells
36	24	D	23	33	29	4511	4366	5307	5161
36	30	A	26	43	29	2830	2708	3242	3120
36	30	B	26	43	29	3594	3438	4335	4179
36	30	C	26	43	29	4248	4055	5140	4947
36	30	D	26	43	29	5160	4918	6192	5950
36	36	A	29	46	29	3067	2946	3539	3418
36	36	B	29	46	29	4046	3891	4956	4800
36	36	C	29	46	29	4788	4595	5867	5673
36	36	D	29	46	29	5810	5567	7099	6857
42	12	A	16	28	30	2507	2577	3467	3537
42	12	B	16	28	30	2670	2889	3131	3170
42	12	C	16	28	30	3478	3507	3830	3860
42	12	D	16	28	30	3971	3989	4307	4325
42	14	A	18	30	32	2671	2739	2942	3010
42	14	B	18	30	32	3075	3114	3400	3440
42	14	C	18	30	32	3747	3776	4147	4177
42	14	D	18	30	32	4590	4609	5288	5306
42	16	A	19	31	32	2778	2846	3080	3148
42	16	B	19	31	32	3196	3235	3552	3592
42	16	C	19	31	32	3891	3920	4325	4354
42	16	D	19	31	32	4754	4772	5487	5506
42	18	A	20	34	32	2950	2941	3268	3258
42	18	B	20	34	32	3407	3357	3794	3744
42	18	C	20	34	32	4393	4312	5108	5028
42	18	D	20	34	32	5049	4939	5819	5709
42	20	A	21	36	32	3104	3056	3459	3411
42	20	B	21	36	32	3582	3486	4009	3913
42	20	C	21	36	32	4615	4479	5387	5251
42	20	D	21	36	32	5297	5123	6122	5943
42	24	A	23	33	32	3314	3266	3724	3676
42	24	B	23	33	32	3852	3756	4370	4274
42	24	C	23	33	32	4965	4829	5866	5730
42	24	D	23	33	32	5709	5535	6579	6405
42	30	A	26	43	32	3679	3553	4144	4018
41	30	B	26	43	32	4554	4370	5416	5230
42	30	C	26	43	32	5649	5402	6675	6428
43	30	D	26	43	32	6561	6258	7729	7426
42	36	A	29	46	32	4076	3950	4705	4579
42	36	B	29	46	32	4903	4718	5845	5659
42	36	C	29	46	32	6150	5904	7261	7015
42	36	D	29	46	32	7187	6884	8512	8209
42	42	A	32	49	32	4393	4267	5109	4983
42	42	B	32	49	32	5533	5348	6641	6455
42	42	C	32	49	32	7001	6755	8392	8146
42	42	D	32	49	32	8158	7855	9803	9500

CANADIAN SOCIETY OF CIVIL ENGINEERS
STANDARD SPECIAL CASTINGS FOR WATER
 Table No. 10—Continued. Standard Branches

Nominal Diam. Inches		Class	Dimensions, Inches			Approximate Weights, Pounds			
A	B		H	J	I	3-Way Branches		4-Way Branches	
						2 Bells	3 Bells	3 Bells	4 Bells
48	12	A	17	29	33	3266	3319	3653	3707
48	12	B	17	29	33	3752	3804	4107	4160
48	12	C	17	29	33	4510	4576	4940	5007
48	12	D	17	29	33	5564	5624	6376	6436
48	14	A	18	30	35	3422	3476	3762	3815
48	14	B	18	30	35	4178	4226	4886	4889
48	14	C	18	30	35	4965	5030	5712	5778
48	14	D	18	30	35	5754	5815	6596	6656
48	16	A	19	31	35	3565	3619	3947	4001
48	16	B	19	31	35	4046	4098	4466	4519
48	16	C	19	31	35	5055	5121	5755	5821
48	16	D	19	31	35	5967	6028	6860	6921
48	18	A	20	34	35	3775	3729	4166	4120
48	18	B	20	34	35	4287	4225	4718	4655
48	18	C	20	34	35	5479	5407	6328	6256
48	18	D	20	34	35	6828	6227	7259	7158
48	20	A	21	36	35	3956	3860	4378	4282
48	20	B	21	36	35	4500	4380	4973	4853
48	20	C	21	36	35	5745	5604	6652	6511
48	20	D	21	36	35	6607	6425	7574	7392
48	24	A	23	38	35	4221	4125	4706	4609
48	24	B	23	38	35	5028	4908	5798	5678
48	24	C	23	38	35	6193	6052	7272	7131
48	24	D	23	38	35	7064	6882	7994	7812
48	30	A	26	43	35	4748	4553	5361	5166
48	30	B	26	43	35	5685	5451	6653	6418
48	30	C	26	43	35	7042	6762	8265	7985
48	30	D	26	43	35	8051	7708	9303	8960
48	36	A	29	46	35	5150	4953	5859	5662
48	36	B	29	46	35	6322	6088	7382	7148
48	36	C	29	46	35	7603	7323	8915	8635
48	36	D	29	46	35	8830	8487	10336	9993
48	42	A	32	49	35	5503	5307	6266	6069
48	42	B	32	49	35	6821	6587	7973	7739
48	42	C	32	49	35	8278	7999	9750	9470
48	42	D	32	49	35	9644	9301	11367	11024
48	48	A	35	52	35	6043	5846	7043	6846
48	48	B	35	52	35	7659	7424	9076	8841
48	48	C	35	52	35	9229	8950	11006	10726
48	48	D	35	52	35				

**CANADIAN SOCIETY OF CIVIL ENGINEERS
STANDARD SPECIAL CASTINGS FOR WATER**

Standard Y Branches, Type 1

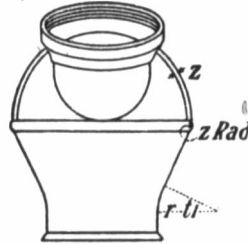
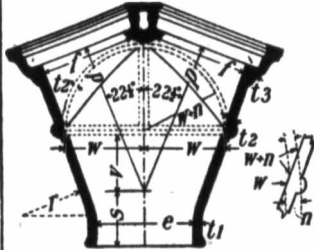

Table No. 11

Nominal Diam., Inch.		Class	s	p	v	w	n	r	Thickness, Inches			Approx. Weight Pounds
e	f								t ₁	t ₂	t ₃	
12	12	D	16.0	21.50	8.00	9.79	1.17	30	.75	1.08	.75	687
14	14	B	16.0	24.00	9.0	11.30	1.08	30	.66	.99	.66	738
14	14	D	16.0	24.00	9.0	11.30	1.32	30	.82	1.22	.82	894
16	16	B	17.0	27.50	10.50	13.00	1.12	30	.70	1.03	.70	942
16	16	D	17.0	27.50	10.50	13.00	1.39	30	.89	1.29	.89	1278
18	18	B	18.0	30.00	12.0	14.70	1.17	30	.75	1.08	.75	1286
18	18	D	18.0	30.00	12.0	14.70	1.46	30	.96	1.36	.96	1607
20	20	B	18.0	34.00	13.50	16.40	1.26	30	.80	1.16	.80	1635
20	20	D	18.0	34.00	13.50	16.40	1.67	30	1.03	1.46	1.03	2296
24	20	B	12.00	34.00	13.50	16.40	1.26	30	.89	1.16	.80	1683
24	20	D	12.00	34.00	13.50	16.40	1.67	30	1.16	1.46	1.03	2393
24	24	B	18.00	38.00	15.25	19.30	1.36	30	.89	1.26	.89	2300
24	24	D	18.00	38.00	15.25	19.30	1.76	30	1.16	1.63	1.16	2967
30	24	A	12.00	38.00	15.25	19.30	1.36	30	.88	1.26	.89	2171
30	24	B	12.00	38.00	15.25	19.30	1.36	30	1.03	1.26	.89	2217
30	24	C	12.00	38.00	15.25	19.30	1.76	30	1.20	1.63	1.16	2717
30	24	D	12.00	38.00	15.25	19.30	1.76	30	1.37	1.83	1.16	2811
30	30	A	18.00	48.00	18.00	23.70	1.22	30	.89	1.22	.88	3153
30	30	B	18.00	48.00	18.00	23.70	1.69	30	1.03	1.47	1.03	3687
30	30	C	18.00	48.00	18.00	23.70	1.88	30	1.20	1.74	1.20	4296
30	30	D	18.00	48.00	18.00	23.70	2.17	30	1.37	2.01	1.37	4941
36	30	A	10.00	48.00	18.00	23.70	1.32	30	.99	1.22	.88	3343
36	30	B	10.00	48.00	18.00	23.70	1.69	30	1.15	1.47	1.03	3874
36	30	C	10.00	48.00	18.00	23.70	1.88	30	1.36	1.74	1.20	4486
36	30	D	10.00	48.00	18.00	23.70	2.17	30	1.56	2.01	1.37	5189
36	36	A	18.00	56.00	21.00	28.20	1.50	24	.99	1.39	.99	4949
36	36	B	18.00	56.00	21.00	28.20	1.79	24	1.15	1.66	1.15	5358
36	36	C	18.00	56.00	21.00	28.20	2.13	24	1.36	1.98	1.36	6804
36	36	D	18.00	56.00	21.00	28.20	2.48	24	1.56	2.31	1.56	8082
42	30	A	6.00	48.00	18.00	23.70	1.32	30	1.10	1.22	.88	3366
42	30	B	6.00	48.00	18.00	23.70	1.69	30	1.28	1.47	1.03	3890
42	30	C	6.00	48.00	18.00	23.70	1.88	30	1.54	1.74	1.20	4543
42	30	D	6.00	48.00	18.00	23.70	2.17	30	1.78	2.01	1.37	5241
42	36	A	10.00	56.00	21.00	28.20	1.50	24	1.10	1.39	.99	4904
42	36	B	10.00	56.00	21.00	28.20	1.79	24	1.28	1.66	1.15	5789
42	36	C	10.00	56.00	21.00	28.20	2.13	24	1.54	1.98	1.36	6761
42	36	D	10.00	56.00	21.00	28.20	2.48	24	1.78	2.31	1.58	8025
42	42	A	18.00	66.00	25.00	33.10	1.72	24	1.10	1.60	1.10	7394
42	42	B	18.00	66.00	25.00	33.10	2.05	24	1.28	1.90	1.28	8417
42	42	C	18.00	66.00	25.00	33.10	2.46	24	1.54	2.28	1.54	10377
42	42	D	18.00	66.00	25.00	33.10	2.85	24	1.78	2.64	1.78	12072
48	36	A	2.00	56.00	21.00	28.20	1.50	24	1.28	1.39	.99	4727
48	36	B	2.00	56.00	21.00	28.20	1.79	24	1.42	1.66	1.15	5584
48	36	C	2.00	56.00	21.00	28.20	2.13	24	1.71	1.98	1.36	6494
48	36	D	2.00	56.00	21.00	28.20	2.48	24	1.96	2.31	1.56	7731
48	42	A	10.00	66.00	25.00	33.10	1.72	24	1.26	1.60	1.10	7345
48	42	B	10.00	66.00	25.00	33.10	2.05	24	1.42	1.90	1.28	8338
48	42	C	10.00	66.00	25.00	33.10	2.46	24	1.71	2.28	1.54	10249
48	42	D	10.00	66.00	25.00	33.10	2.85	24	1.96	2.64	1.78	11924
48	48	A	18.00	76.00	28.00	37.60	1.99	24	1.26	1.86	1.26	10200
48	48	B	18.00	76.00	28.00	37.60	2.32	24	1.42	2.15	1.42	12132
48	48	C	18.00	76.00	28.00	37.60	2.78	24	1.71	2.57	1.71	14716
48	48	D	18.00	76.00	28.00	37.60	3.20	24	1.96	2.95	1.96	16966

**CANADIAN SOCIETY OF CIVIL ENGINEERS
STANDARD SPECIAL CASTINGS FOR WATER**

Y Branches, Type 2

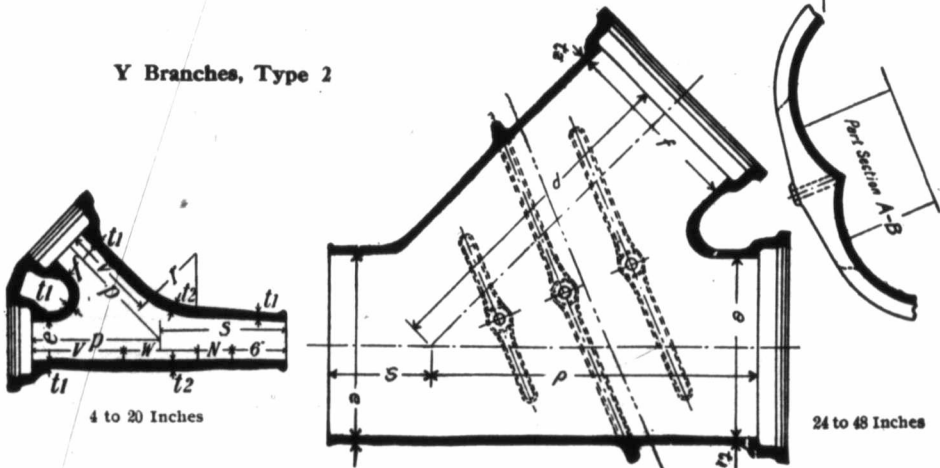
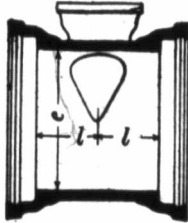

Table No. 12

Nominal Diam., Inch.		Class	s	p	v	w	n	r	Thickness Inches		Approx. Weight Pounds
e	f								t ₁	t ₂	
4	4	D	11.50	10.50	7.18	6.64	2.18	6	.52	.64	103
6	6	D	13.00	13.00	9.27	7.46	3.27	6	.55	.87	181
8	8	D	14.00	16.00	11.85	8.30	3.85	6	.60	.72	291
10	10	D	15.50	18.50	13.94	9.12	4.91	6	.68	.83	434
12	12	D	18.50	21.50	16.54	9.92	4.54	6	.75	.93	632
14	14	B	16.00	24.00	18.62	10.76	4.62	6	.66	.84	690
14	14	D	16.00	24.00	18.62	10.76	4.62	6	.82	1.00	985
16	16	B	17.50	31.00	25.20	11.60	5.70	6	.70	1.03	967
16	16	D	17.50	31.00	25.20	11.60	5.70	6	.89	1.29	1413
18	18	B	18.00	34.00	28.00	12.00	6.00	6	.78	1.12	1358
18	18	D	18.00	34.00	28.00	12.00	6.00	6	.96	1.44	1737
20	20	B	18.75	37.00	30.75	12.50	6.50	6	.80	1.20	1725
20	20	D	18.75	37.00	30.75	12.50	6.50	6	1.03	1.50	2199
24	20	B	18.75	40.00	6	.89	.80	2203
24	20	D	18.75	40.00	6	1.16	1.03	3087
24	24	B	19.75	42.00	6	.89	.89	2600
24	24	D	19.75	42.00	6	1.16	1.16	3599
30	24	A	17.00	49.50	6	.88	.89	3178
30	24	B	17.00	49.50	6	1.03	.89	3874
30	30	A	22.75	52.30	6	.88	.88	3519
30	30	B	22.75	52.50	6	1.03	3.03	4360
36	30	A	19.75	56.00	6	.99	.88	4338
36	30	B	19.75	56.00	6	1.13	1.03	4425
36	36	A	24.00	60.00	6	.99	.99	4951
36	36	B	24.00	60.00	6	1.13	1.15	6509
42	30	A	16.75	63.00	6	1.10	.88	5343
42	30	B	16.75	63.00	6	1.28	1.03	6782
42	36	A	21.00	66.00	6	1.10	.99	6446
42	36	B	21.00	66.00	6	1.28	1.15	7893
42	42	A	25.25	69.00	6	1.10	1.10	7591
42	42	B	25.25	69.00	6	1.28	1.28	9193
48	36	A	18.00	71.00	6	1.26	.99	7550
48	36	B	18.00	71.00	6	1.42	1.15	9500
48	42	A	22.25	74.00	6	1.26	1.10	9116
48	42	B	22.25	74.00	6	1.42	1.28	10987
48	48	A	26.50	77.00	6	1.26	1.26	10599
48	48	B	26.50	77.00	6	1.42	1.42	12554

**CANADIAN SOCIETY OF CIVIL ENGINEERS
STANDARD SPECIAL CASTINGS FOR WATER**



Standard
Blow-off Branches

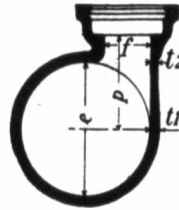

Table No. 13

Nominal Diameter Inches	e	f	Class	l	p	Thickness Inches		Approx. Weight Pounds	Nominal Diameter Inches	e	f	Class	l	p	Thickness Inches		Approx. Weight Pounds
						t ₁	t ₂								t ₁	t ₂	
8	4	D	12	7	.60	.52	227	36	12	A	13	23	.99	.75	1702		
10	4	D	12	8	.68	.52	286	36	12	B	13	23	1.15	.75	1972		
10	6	D	12	8	.68	.55	300	36	12	C	13	23	1.36	.75	2285		
12	4	D	12	10	.75	.52	365	36	12	D	13	23	1.58	.75	2627		
12	6	D	12	10	.75	.55	379	42	12	A	15	26	1.10	.75	2432		
14	4	B	12	11	.66	.52	400	42	12	B	15	26	1.28	.75	2728		
14	4	D	12	11	.82	.52	471	42	12	C	15	26	1.54	.75	3271		
14	6	B	12	11	.66	.55	415	42	12	D	15	26	1.78	.75	3768		
14	6	D	12	11	.82	.55	486	42	16	A	15	26	1.10	.70	2489		
16	4	B	12	12	.70	.52	497	42	16	B	15	26	1.28	.70	2786		
16	4	D	12	12	.89	.52	597	42	16	C	15	26	1.54	.89	3365		
16	6	B	12	12	.70	.55	513	42	16	D	15	26	1.78	.89	3862		
16	6	D	12	12	.89	.55	618	48	13	A	17	30	1.26	.75	3274		
18	4	B	12	13	.75	.52	586	48	12	B	17	30	1.42	.75	3699		
18	4	D	12	13	.96	.52	704	48	12	C	17	30	1.71	.75	4417		
18	6	B	12	13	.75	.55	608	48	12	D	17	30	1.96	.75	5107		
18	6	D	12	13	.96	.55	720	48	16	A	17	30	1.26	.70	3337		
20	4	B	12	14	.80	.52	687	48	16	B	17	30	1.42	.70	3762		
20	4	D	12	14	1.03	.52	850	48	16	C	17	30	1.71	.89	4523		
20	6	B	12	14	.80	.55	705	48	16	D	17	30	1.96	.89	5214		
20	6	D	12	14	1.03	.55	867	54	12	A	19	33	1.35	.75	4287		
24	6	B	12	16	.89	.55	916	54	12	B	19	33	1.55	.75	4945		
24	6	D	12	16	1.16	.55	1149	54	12	C	19	33	1.90	.75	5981		
24	8	B	12	16	.89	.60	985	54	12	D	19	33	2.23	.75	7002		
24	8	D	12	16	1.16	.60	1170	54	16	A	19	33	1.35	.70	4355		
30	8	A	13	20	.88	.60	1269	54	16	B	19	33	1.55	.70	5013		
30	8	B	13	20	1.03	.60	1382	54	16	C	19	33	1.90	.89	6096		
30	8	C	13	20	1.20	.60	1616	54	16	D	19	33	2.23	.89	7126		
30	8	D	13	20	1.37	.60	1867	60	12	A	21	36	1.39	.75	5263		
30	12	A	13	20	.88	.75	1315	60	12	B	21	36	1.67	.75	6159		
30	12	B	13	20	1.03	.75	1426	60	12	C	21	36	2.00	.75	7418		
30	12	C	13	20	1.20	.75	1658	60	12	D	21	36	2.38	.75	8798		
30	12	D	13	20	1.37	.75	1913	60	16	A	21	36	1.39	.70	5386		
36	8	A	13	23	.99	.60	1653	60	16	B	21	36	1.67	.70	6233		
36	8	B	13	23	1.15	.60	1922	60	16	C	21	36	2.00	.89	7542		
36	8	C	13	23	1.36	.60	2234	60	16	D	21	36	2.38	.89	8927		
36	8	D	13	23	1.58	.60	2576										

**CANADIAN SOCIETY OF CIVIL ENGINEERS
STANDARD SPECIAL CASTINGS FOR WATER**

**Standard
Blow-off Branches
with Manhole**

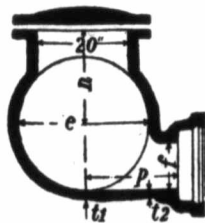
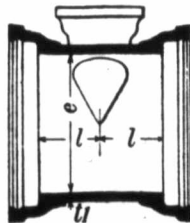

Table No. 14

Approximate Weight of Cap,
290 Pounds

Nom'l Diam. Inches	Class		l	p	n	Thickness Inches		Approximate Weight, Lbs.	Nom'l Diam. Inches	Class		l	p	n	Thickness Inches		Approximate Weight, Lbs.
	e	f				t ₁	t ₂			e	f				t ₁	t ₂	
30	8	A	17	20	21	.88	.60	1628	48	12	A	17	30	30	1.26	.75	3391
30	8	B	17	20	21	1.03	.60	1758	48	12	B	17	30	30	1.42	.75	3803
30	8	C	17	20	21	1.20	.60	2018	48	12	C	17	30	30	1.71	.75	4497
30	8	D	17	20	21	1.37	.60	2290	48	12	D	17	30	30	1.98	.75	5167
30	12	A	17	30	21	.88	.75	1672	48	16	A	17	30	30	1.28	.70	3454
30	12	B	17	30	21	1.03	.75	1803	48	16	B	17	30	30	1.49	.70	3866
30	12	C	17	30	21	1.20	.75	2057	48	16	C	17	30	30	1.71	.89	4504
30	12	D	17	30	21	1.37	.75	2335	48	16	D	17	30	30	1.96	.89	5274
36	8	A	17	23	24	.99	.60	2045	54	12	A	19	33	33	1.55	.75	4390
36	8	B	17	23	24	1.15	.60	2261	54	12	B	19	33	33	1.55	.75	5032
36	8	C	17	23	24	1.36	.60	2690	54	12	C	19	33	33	1.90	.75	6039
36	8	D	17	23	24	1.58	.60	3071	54	12	D	19	33	33	2.23	.75	7033
36	12	A	17	33	24	.99	.75	2094	54	16	A	19	33	33	1.35	.70	4458
36	12	B	17	33	24	1.15	.75	2395	54	16	B	19	33	33	1.55	.70	5100
36	12	C	17	33	24	1.36	.75	2741	54	16	C	19	33	33	1.90	.89	6154
36	12	D	17	33	24	1.58	.75	3122	54	16	D	19	33	33	2.23	.89	7157
42	12	A	17	26	27	1.10	.75	2726	60	12	A	21	36	36	1.39	.75	5357
42	12	B	17	26	27	1.28	.75	3033	60	12	B	21	36	36	1.67	.75	6290
42	12	C	17	26	27	1.54	.75	3595	60	12	C	21	36	36	2.00	.75	7462
42	12	D	17	26	27	1.78	.75	4109	60	12	D	21	36	36	2.38	.75	8910
42	16	A	17	26	27	1.10	.70	2783	60	16	A	21	36	36	1.39	.70	5429
42	16	B	17	26	27	1.28	.70	3090	60	16	B	21	36	36	1.67	.70	6304
42	16	C	17	26	27	1.54	.89	3689	60	16	C	21	36	36	2.00	.89	7387
42	16	D	17	26	27	1.78	.89	4203	60	16	D	21	36	36	2.38	.89	8929

STANDARD MANHOLE PIPE

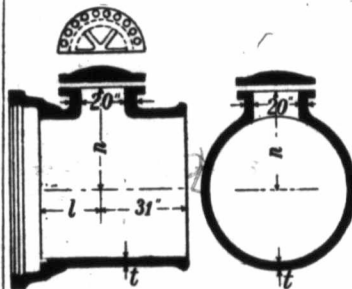

Table No. 15

Nom'l Diam. Inches	Class	n	t	Weight Pounds	Nom'l Diam. Inches	Class	n	t	Weight Pounds
30	A	21	.88	1536	48	A	30	1.26	3194
30	B	21	1.03	1711	48	B	30	1.42	3610
30	C	21	1.20	1973	48	C	30	1.71	4292
30	D	21	1.37	2245	48	D	30	1.96	4958
36	A	24	.99	1953	54	A	33	1.35	4006
36	B	24	1.15	2260	54	B	33	1.55	4598
36	C	24	1.36	2614	54	C	33	1.90	5578
36	D	24	1.58	3012	54	D	33	2.23	6522
42	A	27	1.10	2835	60	A	36	1.39	4750
42	B	27	1.28	2869	60	B	36	1.67	5606
42	C	27	1.54	3446	60	C	36	2.00	6720
42	D	27	1.78	3971	60	D	36	2.38	7959

Standard Manhole Pipe
Approximate Weight of Cap, 290 Pounds

l—17 inches on 30 inches to 48 inches; 19 inches on 54 inches; 21 inches on 60 inches diameter.

**CANADIAN SOCIETY OF CIVIL ENGINEERS
STANDARD SPECIAL CASTINGS FOR WATER
Standard Reducers and Increases, Type No. 1.**

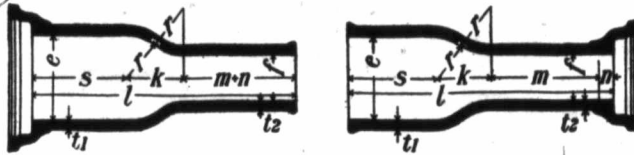

Table No. 16

Diam. Inches		k	m	r	Thickness, Inches		Weights, Pounds	
e	f				t ₁	t ₂	Large End Bell	Small End Bell
6	4	3.30	14.70	3	.55	.52	99	88
8	4	5.30	12.70	4	.60	.52	131	108
8	6	3.90	14.10	4	.60	.55	149	138
10	4	7.10	10.90	5	.68	.52	164	132
10	6	6.00	12.00	5	.68	.55	181	160
10	8	4.40	18.60	5	.68	.60	205	195
12	6	7.90	10.10	6	.75	.55	225	191
12	8	6.60	11.40	6	.75	.60	246	224
12	10	4.80	18.20	6	.75	.68	271	260

Class D. 6x4 inches to 12x10 inches. On all sizes n=2 inches.
On all sizes l=30 inches and s=10 inches.

STANDARD REDUCERS AND INCREASES

Type No. 2

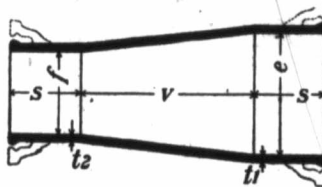

6x4 inches to
60x54 inches

Table No. 17

Nominal Diam. Inches		v	Thickness, Inches		Class	Weights, Pounds		
e	f		t ₁	t ₂		Spigot Ends	Large End Bell	Small End Bell
6	4	18	.55	.52	D	82	104	97
8	4	18	.60	.52	D	104	132	119
8	6	18	.60	.55	D	121	150	143
10	4	18	.68	.52	D	131	162	146
10	6	18	.68	.55	D	150	180	169
10	8	18	.68	.60	D	170	201	198
12	4	18	.75	.52	D	163	201	179
12	6	18	.75	.55	D	181	218	202
12	8	18	.75	.60	D	202	240	231
12	10	18	.75	.68	D	229	267	261
14	6	20	.66	.55	B	194	249	216
14	6	20	.82	.55	D	234	288	256
14	8	20	.66	.60	B	220	275	248
14	8	20	.82	.60	D	260	314	288

On all sizes s=8 inches

**CANADIAN SOCIETY OF CIVIL ENGINEERS
STANDARD SPECIAL CASTINGS FOR WATER**

Standard Reducers and Increases, Type No. 2

Table No. 17—Continued

Nominal Diam. Inches		v	Thickness, Inches		Class	Weights, Pounds		
e	f		t ₁	t ₂		Spigot Ends	Large End Bell	Small End Bell
14	10	20	.66	.68	B	250	305	279
14	10	20	.82	.68	D	290	344	320
14	12	20	.66	.75	B	284	339	321
14	12	20	.82	.75	D	324	378	360
16	6	20	.70	.55	B	226	300	248
16	6	20	.89	.55	D	278	355	300
16	8	20	.70	.60	B	252	326	280
16	8	20	.89	.60	D	304	381	332
16	10	20	.70	.68	B	282	356	312
16	10	20	.89	.68	D	334	410	364
16	12	20	.70	.75	B	317	391	353
16	12	20	.89	.75	D	368	445	405
16	14	20	.70	.66	B	315	389	370
16	14	20	.89	.82	D	407	484	461
18	8	20	.75	.60	B	287	374	315
18	8	20	.96	.60	D	345	438	373
18	10	20	.75	.68	B	317	404	347
18	10	20	.96	.68	D	375	468	405
18	12	20	.75	.75	B	352	438	388
18	12	20	.96	.75	D	410	502	446
18	14	20	.75	.66	B	350	437	406
18	14	20	.96	.82	D	448	541	502
18	16	20	.75	.70	B	383	469	457
18	16	20	.96	.89	D	492	585	569
20	10	26	.80	.68	B	414	516	445
20	10	26	1.03	.68	D	499	615	529
20	12	26	.80	.75	B	455	556	491
20	12	26	1.03	.75	D	539	656	576
20	14	26	.80	.66	B	453	554	508
20	14	26	1.03	.82	D	583	700	638
20	16	26	.80	.70	B	490	592	564
20	16	26	1.03	.89	D	635	751	711
20	18	26	.80	.75	B	531	633	617
20	18	26	1.03	.96	D	683	800	776
24	14	26	.89	.66	B	552	680	607
24	14	26	1.16	.82	D	710	866	764
24	16	26	.89	.70	B	589	717	663
24	16	26	1.16	.89	D	762	917	838
24	18	26	.89	.75	B	630	758	717
24	18	26	1.16	.96	D	810	965	901
24	20	26	.89	.80	B	675	803	776
24	20	26	1.16	1.03	D	871	1027	987
30	18	26	.88	.75	A	710	903	796
30	18	26	1.03	.75	B	791	969	878
30	18	26	1.20	.96	C	956	1166	1048
30	18	26	1.37	.96	D	1054	1305	1146
30	20	26	.88	.80	A	754	947	856

On all sizes s = 8 inches

**CANADIAN SOCIETY OF CIVIL ENGINEERS
STANDARD SPECIAL CASTINGS FOR WATER
Standard Reducers and Increasers, Type No. 2**

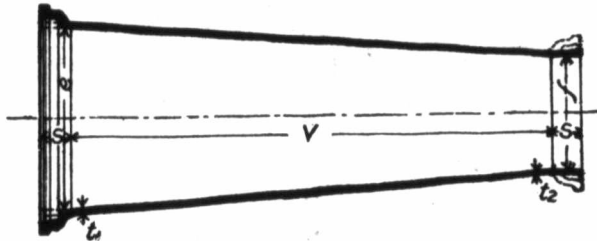

Long Increaser. 48 to 80 inches x 182 inches v

Table No. 17—Continued

Nominal Diam. Inches		v	Thickness, Inches		Class	Weights, Pounds		
e	f		t ₁	t ₂		Spigot Ends	Large End Bell	Small End Bell
30	20	26	1.03	.80	B	886	1014	987
30	20	26	1.20	1.03	C	1018	1227	1134
30	20	26	1.37	1.03	D	1115	1366	1232
30	20	66	.88	.80	A	1468	1661	1569
30	20	66	1.03	.80	B	1626	1804	1728
30	20	66	1.20	1.03	C	1981	2190	2098
30	20	66	1.37	1.03	D	2172	2423	2289
30	24	26	.88	.89	A	854	1047	981
30	24	26	1.03	.89	B	935	1113	1063
30	24	26	1.20	1.16	C	1144	1354	1300
30	24	26	1.37	1.16	D	1242	1493	1398
30	24	66	.88	.89	A	1661	1921	1869
30	24	66	1.03	.89	B	1820	1998	1946
30	24	66	1.20	1.16	C	2228	2438	2384
30	24	66	1.37	1.16	D	2419	2670	2575
36	20	32	.99	.80	A	1039	1286	1141
36	20	32	1.15	.80	B	1170	1450	1272
36	20	32	1.36	1.03	C	1417	1739	1534
36	20	32	1.58	1.03	D	1589	1951	1705
36	20	66	.99	.80	A	1771	2018	1872
36	20	66	1.15	.80	B	1994	2274	2095
36	20	66	1.36	1.03	C	2416	2738	2533
36	20	66	1.58	1.03	D	2710	3072	2827
36	24	32	.99	.89	A	1153	1339	1280
36	24	32	1.15	.89	B	1283	1564	1411
36	24	32	1.36	1.16	C	1562	1884	1718
36	24	32	1.58	1.16	D	1734	2096	1890
36	24	66	.99	.89	A	1964	2211	2091
36	24	66	1.15	.89	B	2188	2468	2314
36	24	66	1.36	1.16	C	2664	2985	2820
36	24	66	1.58	1.16	D	2957	3319	3113
36	30	32	.99	.88	A	1243	1490	1436
36	30	32	1.15	1.03	B	1467	1747	1645
36	30	32	1.36	1.20	C	1730	2051	1939
36	30	32	1.58	1.37	D	2013	2375	2264

On all sizes s=8 inches.

**CANADIAN SOCIETY OF CIVIL ENGINEERS
STANDARD SPECIAL CASTINGS FOR WATER
Standard Reducers and Increases, Type No. 2**

Table No. 17—Continued

Nominal Diam., Inches			Thickness, Inches		Class	Weights, Pounds		
e	f	v	t ₁	t ₂		Spigot Ends	Large End Bell	Small End Bell
36	30	66	.99	.89	A	2119	2866	2312
36	30	66	1.15	1.03	B	2502	2783	2680
36	30	66	1.36	1.20	C	2950	3271	3159
36	30	66	1.58	1.37	D	3434	3796	3684
42	20	32	1.10	.80	A	1262	1602	1364
42	20	32	1.28	.80	B	1413	1768	1515
42	20	32	1.54	1.03	C	1753	2168	1869
42	20	32	1.78	1.03	D	1975	2445	2092
42	20	66	1.10	.80	A	2152	2491	2254
42	20	66	1.28	.80	B	2410	2764	2511
42	20	66	1.54	1.03	C	2989	3405	3106
42	20	66	1.78	1.03	D	3369	3839	3486
42	24	32	1.10	.89	A	1876	1715	1504
42	24	32	1.28	.89	B	1527	1881	1654
42	24	32	1.54	1.16	C	1898	2313	2053
42	24	32	1.78	1.16	D	2120	2590	2276
42	24	66	1.10	.89	A	2346	2685	2472
42	24	66	1.28	.89	B	2608	2958	2780
42	24	66	1.54	1.16	C	3237	3652	3392
42	24	66	1.78	1.16	D	3616	4096	3772
42	30	32	1.10	.88	A	1467	1806	1660
42	30	32	1.28	1.03	B	1711	2065	1889
42	30	32	1.54	1.20	C	2065	2480	2275
42	30	32	1.78	1.37	D	2399	2869	2650
42	30	66	1.10	.88	A	2500	2830	2693
42	30	66	1.28	1.03	B	2917	3271	3095
42	30	66	1.54	1.20	C	3523	3938	3732
42	30	66	1.78	1.37	D	4093	4563	4344
42	36	32	1.10	.99	A	1645	1984	1891
42	36	32	1.28	1.15	B	1926	2281	2297
42	36	32	1.54	1.36	C	2320	2735	2642
42	36	32	1.78	1.58	D	2714	3184	3076
42	36	66	1.10	.99	A	2803	3143	3050
42	36	66	1.28	1.15	B	3285	3639	3565
42	36	66	1.54	1.36	C	3958	4373	4279
42	36	66	1.78	1.58	D	4631	5101	4993
48	30	66	1.26	.88	A	2975	3381	3168
48	30	66	1.42	1.03	B	3428	3883	3606
48	30	66	1.71	1.20	C	4092	4641	4801
48	30	66	1.96	1.37	D	4762	5388	5013
48	30	132	1.26	.88	A	5363	5769	5556
48	30	132	1.42	1.03	B	6180	6635	6359
48	30	132	1.71	1.20	C	7379	7928	7588
48	30	132	1.96	1.37	D	8588	9214	8839
48	36	66	1.26	.90	A	3278	3684	3525
48	36	66	1.42	1.15	B	3796	4252	4077
48	36	66	1.71	1.36	C	4527	5076	4849

On all sizes s—8 inches.

CANADIAN SOCIETY OF CIVIL ENGINEERS
STANDARD SPECIAL CASTINGS FOR WATER
Standard Reducers and Increases, Type No. 2
Table No. 17—Continued

Nominal Diam. Inches		v	Thickness, Inches		Class	Weights, Pounds		
e	f		t ₁	t ₂		Spigot Ends	Large End Bell	Small End Bell
48	36	66	1.96	1.58	D	5300	5925	5662
48	36	132	1.26	.99	A	5909	6316	6156
48	36	132	1.42	1.15	B	6844	7299	7125
48	36	132	1.71	1.36	C	8164	8713	8485
48	36	132	1.96	1.58	D	9558	10184	9920
48	42	66	1.26	1.10	A	3659	4066	3996
48	42	66	1.42	1.28	B	4212	4667	4564
48	42	66	1.71	1.54	C	5100	5649	5516
48	42	66	1.96	1.78	D	5959	6585	6429
48	42	132	1.26	1.10	A	6597	7008	6936
48	42	132	1.42	1.28	B	7594	8049	7948
48	42	132	1.71	1.54	C	9197	9746	9612
48	42	132	1.96	1.78	D	10747	11878	11217
54	36	66	1.35	.99	A	3722	4228	3969
54	36	66	1.55	1.15	B	4330	4925	4610
54	36	66	1.90	1.36	C	5259	5953	5580
54	36	66	2.23	1.58	D	6181	6995	6543
54	36	132	1.35	.99	A	6710	7216	6957
54	36	132	1.55	1.15	B	7806	8401	8087
54	36	132	1.90	1.36	C	9484	10178	9805
54	36	132	2.23	1.58	D	11148	11962	11510
54	42	66	1.35	1.10	A	4103	4609	4442
54	42	66	1.55	1.28	B	4745	5340	5100
54	42	66	1.90	1.54	C	5832	6526	6247
54	42	66	2.23	1.78	D	6841	7655	7310
54	42	132	1.35	1.10	A	7398	7993	7737
54	42	132	1.55	1.28	B	8556	9151	8910
54	42	132	1.90	1.54	C	10517	11211	10932
54	42	132	2.23	1.78	D	12338	13152	12807
54	48	66	1.35	1.26	A	4578	5083	4984
54	48	66	1.55	1.42	B	5256	5851	5711
54	48	66	1.90	1.71	C	6401	7095	6959
54	48	66	2.23	1.96	D	7512	8326	8137
54	48	132	1.35	1.26	A	8253	8759	8609
54	48	132	1.55	1.42	B	9478	10073	9933
54	48	132	1.90	1.71	C	11544	12239	12093
54	48	132	2.23	1.96	D	13550	14364	14175
60	36	66	1.39	.99	A	4096	4711	4342
60	36	66	1.67	1.15	B	4906	5576	5186
60	36	66	2.00	1.36	C	5867	6692	6189
60	36	66	2.38	1.58	D	6960	7934	7322
60	36	132	1.39	.99	A	7384	7999	7631
60	36	132	1.67	1.15	B	8846	9516	9126
60	36	132	2.00	1.36	C	10581	11405	10902
60	36	132	2.38	1.58	D	12554	13527	12916
60	42	66	1.39	1.10	A	4477	5092	4816
60	42	66	1.67	1.28	B	5321	5991	5676

On all sizes s=8 inches.

**CANADIAN SOCIETY OF CIVIL ENGINEERS
STANDARD SPECIAL CASTINGS FOR WATER**

Standard Reducers and Increases, Type No. 2

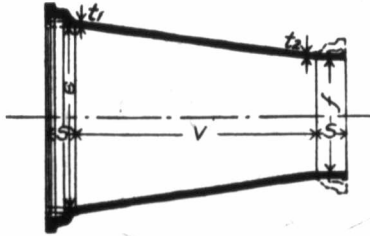

Short Increaser, 48 to 80 x 66 inches v

Table No. 17—Continued

Nominal Diam. Inches		v	Thickness, Inches		Class	Weights, Pounds		
e	f		t ₁	t ₂		Spigot Ends	Large End Bell	Small End Bell
60	42	66	2.00	1.54	C	6440	7264	6855
60	42	66	2.38	1.78	D	7619	8593	8089
60	42	132	1.39	1.10	A	8072	8687	8411
60	42	132	1.67	1.28	B	9595	10265	9956
60	42	132	2.00	1.54	C	11614	12439	12030
60	42	132	2.38	1.78	D	13743	14716	14213
60	48	66	1.39	1.26	A	4957	5572	5363
60	48	66	1.67	1.42	B	5832	6502	6237
60	48	66	2.00	1.71	C	7006	7830	7555
60	48	66	2.38	1.96	D	8285	9259	8910
60	48	132	1.39	1.26	A	8938	9552	9344
60	48	132	1.67	1.42	B	10517	11187	10972
60	48	132	2.00	1.71	C	12634	13453	13133
60	48	132	2.38	1.96	D	14943	15917	15568
60	54	66	1.39	1.35	A	5404	6019	5910
60	54	66	1.67	1.55	B	6348	7018	6961
60	54	66	2.00	1.90	C	7750	8574	8444
60	54	66	2.38	2.23	D	9178	10152	9992
60	54	132	1.39	1.35	A	9745	10860	10251
60	54	132	1.67	1.55	B	11462	12132	12075
60	54	132	2.00	1.90	C	13979	14803	14673
60	54	132	2.38	2.23	D	16557	17530	17371

On all sizes s=8 inches.

**CANADIAN SOCIETY OF CIVIL ENGINEERS
STANDARD SPECIAL CASTINGS FOR WATER**

Standard Sleeves

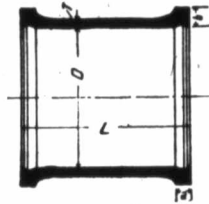

For dimensions a and b see Table No. 1

Table No. 18

Nom'l Diam. Inches	Class	D	L	T	Approx. Weight Pounds	Nom'l Diam. Inches	Class	D	L	T	Approx. Weight Pounds
4	D	5.80	10	.65	47	36	B	39.40	15	1.40	948
4	D	5.80	15	.65	61	36	C	39.80	15	1.60	1077
6	D	7.90	10	.70	68	36	D	40.20	15	1.80	1217
6	D	7.90	15	.70	87	36	A	39.00	24	1.25	1202
8	D	10.10	12	.75	104	36	B	39.40	24	1.40	1362
8	D	10.10	15	.75	119	36	C	39.80	24	1.60	1568
10	D	12.20	12	.80	123	36	D	40.20	24	1.80	1772
10	D	12.20	18	.80	176	42	A	45.80	15	1.40	1097
12	D	14.80	14	.85	174	42	B	45.60	15	1.50	1184
12	D	14.80	18	.85	223	42	C	46.20	15	1.75	1881
14	B	16.20	15	.85	220	42	D	46.70	15	1.95	1561
14	B	16.20	18	.85	249	42	A	45.80	24	1.40	1577
14	D	16.50	15	.90	240	42	B	45.60	24	1.50	1702
14	D	16.50	18	.90	280	42	C	46.20	24	1.75	1997
16	B	18.50	15	.90	274	42	D	46.70	24	1.95	2262
16	B	18.50	24	.90	391	48	A	51.60	15	1.50	1337
16	D	18.90	15	1.00	305	48	B	51.90	15	1.65	1481
16	D	18.90	24	1.00	443	48	C	52.50	15	1.95	1752
18	B	20.60	15	.95	321	48	D	53.10	15	2.20	1986
18	B	20.60	24	.95	462	48	A	51.60	24	1.50	1922
18	D	21.00	15	1.05	360	48	B	51.90	24	1.65	2129
18	D	21.00	24	1.05	518	48	C	52.50	24	1.95	2532
20	B	22.70	15	1.00	374	48	D	53.10	24	2.20	2379
20	B	22.70	24	1.00	532	54	A	57.70	15	1.60	1612
20	D	23.10	15	1.15	440	54	B	58.20	15	1.80	1835
20	D	23.10	24	1.15	625	54	C	58.90	15	2.15	2156
24	B	26.90	15	1.05	477	54	D	59.50	15	2.45	2450
24	B	26.90	24	1.05	680	54	A	57.70	24	1.60	2316
24	D	27.40	15	1.25	533	54	B	58.20	24	1.80	2634
24	D	27.40	24	1.25	821	54	C	58.90	24	2.15	3126
30	A	32.80	15	1.15	648	54	D	59.50	24	2.45	3571
30	B	33.10	15	1.15	652	60	A	63.90	15	1.70	1906
30	C	33.50	15	1.32	760	60	B	64.50	15	1.90	2127
30	D	33.80	15	1.50	876	60	C	65.30	15	2.25	2491
30	A	32.80	24	1.15	943	60	D	65.90	15	2.60	2895
30	B	33.10	24	1.15	949	60	A	63.90	24	1.70	2731
30	C	33.50	24	1.32	1088	60	B	64.50	24	1.90	3058
30	D	33.80	24	1.50	1262	60	C	65.30	24	2.25	3601
36	A	39.00	15	1.25	833	60	D	65.90	24	2.60	4231

**CANADIAN SOCIETY OF CIVIL ENGINEERS
STANDARD SPECIAL CASTINGS FOR WATER**

Standard Caps. Table No. 19

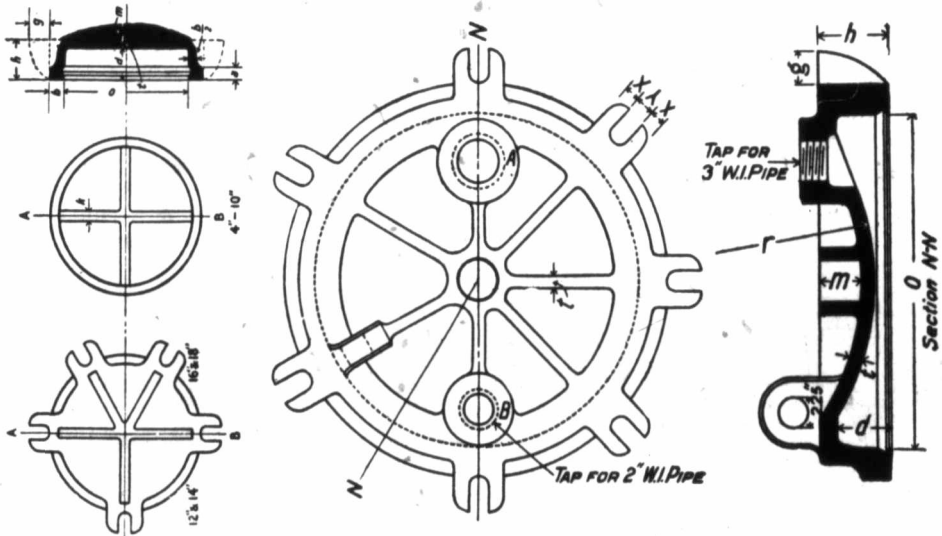

Bosses A and B cast on only when so ordered

Nominal Diam. Inches	Class	d	o	l	t	m	k	r	Approx. Weight Pounds
4	D	4.00	5.7060	26
6	D	4.00	7.8065	40
8	D	4.00	10.0675	59
10	D	4.00	12.1075	1.50	.75	16.20	81
12	D	4.00	14.2075	1.75	.75	18.70	104
14	B	4.00	16.1090	1.90	.75	22.40	140
14	D	4.00	16.4590	1.90	.75	22.40	149
16	B	4.00	18.40	...	1.00	2.00	.75	27.00	188
16	D	4.00	19.80	...	1.00	2.00	.75	27.00	196
18	B	4.00	20.50	...	1.00	2.00	1.00	32.00	226
18	D	4.00	20.92	...	1.00	2.00	1.00	32.90	242
20	B	4.00	22.60	...	1.00	3.00	1.00	18.20	278
20	D	4.00	23.06	...	1.00	3.00	1.00	18.20	308
24	B	4.00	26.80	2.50	1.05	3.50	1.00	23.50	392
24	D	4.00	27.32	2.50	1.05	3.50	1.00	23.60	442
30	A	4.50	32.74	2.62	1.15	3.50	1.15	34.80	589
30	B	4.50	33.00	2.62	1.15	3.50	1.15	34.80	596
30	C	4.50	33.40	2.62	1.15	3.50	1.15	34.80	647
30	D	4.50	33.74	2.62	1.15	3.50	1.15	34.90	704
36	A	4.60	38.96	3.12	1.25	4.00	1.25	44.00	840
36	B	4.60	39.30	3.12	1.30	3.95	1.25	44.00	918
36	C	4.60	39.70	3.12	1.35	3.90	1.25	44.00	996
36	D	4.60	40.18	3.12	1.40	3.85	1.25	44.00	1084
42	A	5.00	45.20	3.37	1.40	4.00	1.40	63.50	1300
42	B	5.00	45.50	3.37	1.50	3.90	1.40	63.50	1388
42	C	5.00	46.10	3.37	1.60	3.80	1.40	63.50	1539
42	D	5.00	46.58	3.37	1.70	3.70	1.40	63.50	1679
48	A	5.00	51.50	3.62	1.70	4.00	1.50	76.50	1772
48	B	5.00	51.80	3.62	1.80	3.90	1.50	76.50	1948
48	C	5.00	52.40	3.62	2.00	3.70	1.50	76.50	2144
48	D	5.00	52.98	3.62	2.10	3.60	1.50	76.50	2341
54	A	5.50	57.96	3.87	1.90	4.50	1.50	82.00	2399
54	B	5.50	58.10	3.87	2.00	4.40	1.50	82.00	2519
54	C	5.50	58.80	3.87	2.10	4.30	1.50	82.00	2770
54	D	5.50	59.40	3.87	2.20	4.20	1.50	82.00	3009
60	A	5.50	63.80	4.12	2.00	4.50	1.50	99.00	2868
60	B	5.50	64.40	4.12	2.10	4.40	1.50	99.00	3082
60	C	5.50	65.20	4.12	2.20	4.30	1.50	99.00	3388
60	D	5.50	65.82	4.12	2.30	4.20	1.50	99.00	3687

**CANADIAN SOCIETY OF CIVIL ENGINEERS
STANDARD SPECIAL CASTINGS FOR WATER**

Standard Plugs

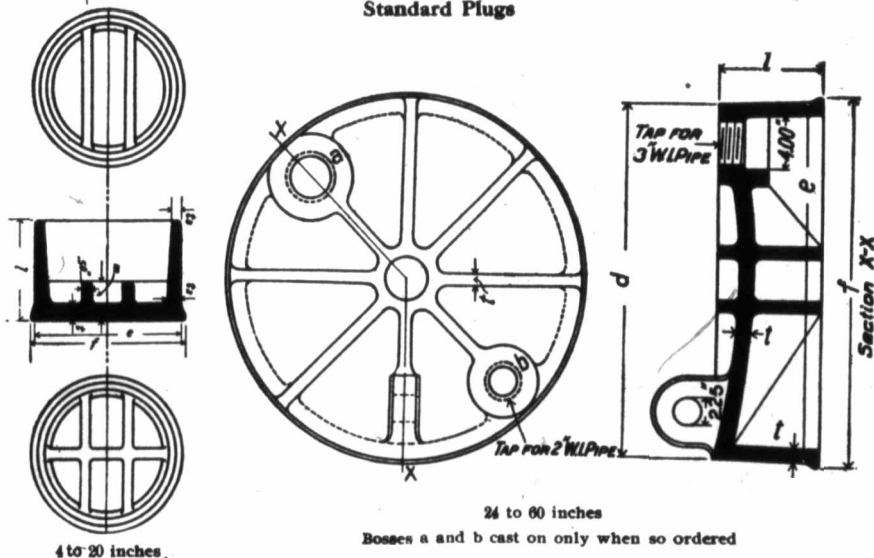

24 to 60 inches

Bosses a and b cast on only when so ordered

Table No. 20

Nominal Diam. Inches	Class	e	f	d	l	m	Thickness, Inches			Number of Ribs	Approx. Weight Pounds
							t ₁	t ₂	t ₃		
4	D	4.90	5.28	5.5050	.40	.20	..	8
6	D	7.00	7.38	5.5060	.40	.20	..	14
8	D	9.15	9.65	5.50	2.0	.60	.40	.20	2	24
10	D	11.20	11.70	6.00	2.0	.70	.50	.20	2	38
12	D	13.30	13.80	6.00	2.0	.75	.50	.20	2	60
14	B	15.30	15.80	6.00	2.0	.70	.50	.20	2	63
14	D	15.65	16.15	6.00	2.0	.75	.50	.20	2	65
16	B	17.40	17.90	6.50	2.0	.70	.50	.30	3	90
16	D	17.80	18.30	6.50	2.0	.80	.60	.30	3	96
18	B	19.60	20.00	6.50	2.50	.75	.60	.30	3	111
18	D	19.92	20.42	6.50	2.50	.85	.60	.30	3	121
20	B	21.60	22.10	6.50	2.75	.85	.60	.30	3	151
20	D	22.08	22.58	6.50	2.75	1.00	.60	.30	3	156
24	B	25.92	26.30	25.68	8.089	4	375
24	D	26.44	26.82	26.20	8.0	1.16	4	472
30	A	31.86	32.24	31.62	8.088	4	451
30	B	32.12	32.50	31.88	8.0	1.03	4	556
30	C	32.52	32.90	32.28	8.0	1.20	4	641
30	D	32.96	33.24	32.62	8.0	1.37	4	723
36	A	38.08	38.46	37.84	8.099	4	682
36	B	38.42	38.80	38.18	8.0	1.15	4	796
36	C	38.82	39.20	38.58	8.0	1.36	4	914
36	D	39.28	39.66	39.04	8.0	1.68	4	1050
42	A	44.32	44.70	44.08	9.0	1.10	4	991
42	B	44.62	45.00	44.38	9.0	1.28	4	1136
42	C	45.22	45.60	44.98	9.0	1.54	4	1252
42	D	45.70	46.08	45.46	9.0	1.78	4	1551
48	A	50.62	51.00	50.38	9.0	1.26	4	1349
48	B	50.92	51.30	50.68	9.0	1.42	4	1508
48	C	51.52	51.90	51.28	9.0	1.71	4	1900
48	D	52.10	52.48	51.86	9.0	1.96	4	2047
54	A	56.78	57.16	56.54	9.0	1.35	4	1697
54	B	57.22	57.60	56.98	9.0	1.55	4	1945
54	C	57.92	58.30	57.68	9.0	1.90	4	2356
54	D	58.52	58.90	58.28	9.0	2.23	4	2732
60	A	62.92	63.30	62.68	9.0	1.39	4	2045
60	B	63.52	63.90	62.88	9.0	1.67	4	2434
60	C	64.32	64.70	64.08	9.0	2.00	4	2904
60	D	64.94	65.32	64.70	9.0	2.38	4	3397