

# The CANADIAN THRESHERMAN AND FARMER

WINNIPEG CANADA  
MAY  
NINETEEN SIXTEEN

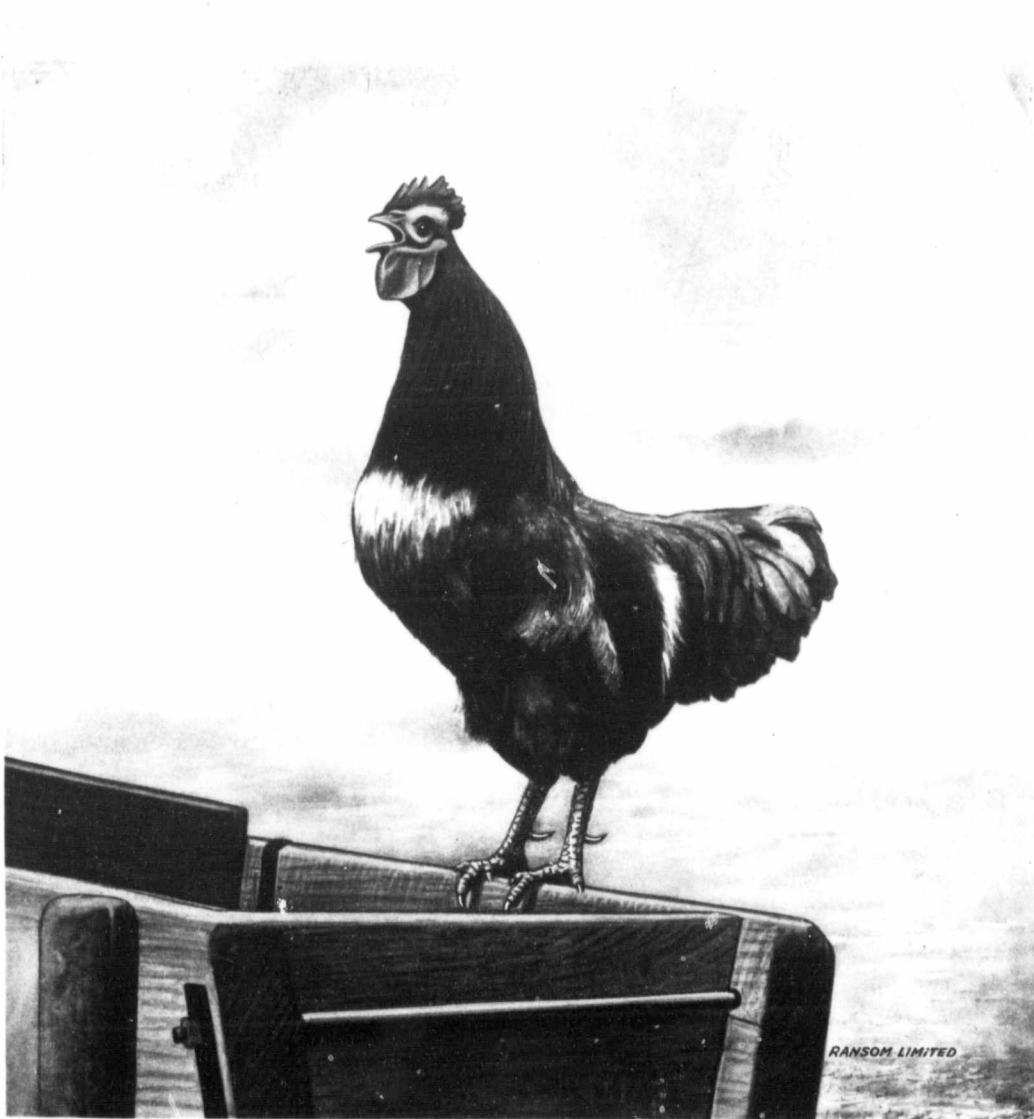

*Published Monthly by E. H. HEATH CO. LIMITED — Our Fourteenth Year*

# CASE Feeders Pay for Them- selves as Time & Labor Savers

The thresherman that wants the *very best* feeder for his work will be interested in a Case feeder. It offers you a feeder that is found today on the machines of hundreds of threshermen. Its success as a time, labor and money saver has been *proved*.

These are not mere *claims* but *actual facts* based on testimonials received from Case users in the big threshing territories of U. S. and Canada. A user from Texas recently wrote us: "We certainly are well pleased with our Case feeder. It places the bundles to the cylinder in a perfect manner without slugging. It is a great labor saving device." Another says of his Case feeder: "I have run threshing machinery for 15 years and have used \_\_\_\_\_, \_\_\_\_\_, and \_\_\_\_\_ feeders, but will say the Case feeder is the best feeder I have ever seen. I have today bought a Case in preference to all other makes."

## CASE

### Fits Any Case Machine

Case feeders are built with the same care and foresight as are all other Case products. They have been built especially for Case machines and thus they fit Case machines perfectly. The thresherman that wants to cut labor and time costs will find a Case feeder a worthy addition to his outfit.

Here are a few details of construction: The crankshaft is protected by the straw governor shoes which prevent winding of straw in any kind or condition of grain. In Case feeders the cutter bars have serrated section knives and require no sharpening. These are far more effective than rotary band cutters.

The retarder has three speeds which may be regulated to suit the condition of the straw.

### Easily & Quickly Attached

The carrier is self supporting and can be folded in half a minute with one hand.

The bearings on the crankshaft and on the swinging hangers are of maplewood boxes, boiled in oil. Improved babbitted boxes have been provided for the hopper bottom shaft.

But there are many more features that cannot be given in this limited space. Throughout the feeder we have used the utmost care in design and construction to make it the most efficient on the market. If you are interested in a feeder that will help swell your income get in touch with our nearest branch house. They will furnish full details.

J. I. CASE THRESHING MACHINE CO., Inc. 759 Liberty St. RACINE, WISCONSIN

Canadian Branches: Winnipeg, Regina, Calgary, Toronto and Saskatoon



# What Qualities Do You Look For in a Threshing Machine?

The threshing machine that you are sure saves the grain is the one that puts the money in the thresherman's pocket.

Case threshers have behind them the most remarkable records as grain savers. This fact is evidenced by the thousands of letters received from Case users from every state in the Union—the Canadian Provinces, South America, Europe and the Phillipines. This proof of Case supremacy is due to the many time and money saving qualities found in Case machines.

Here are some reasons that prove our claims. The straw rack on Case threshing machines has a large separating area. Its motion is scientifically and practically figured out for thumping or beating the grain out of the straw. Also, bear in mind, please, that the straw rack in a Case machine is made in only one piece; another instance of Case simplicity.

# CASE

## Threshes all Kinds of Seeds

Then, too, there is the large cylinder which every Case thresherman appreciates. With its concave and extensive grate surfaces it threshes all kind of grains and seeds perfectly. The cylinder has an enormous capacity. Threshermen have told us of cases where the bundles were actually dripping with water and the large Case cylinder did the job beyond all expectations. Weather conditions won't keep a Case machine from working. It is designed to give service.

On Case machines you will be surprised how few belts and pulleys are used. You will notice the absence of complicating parts. Adjustments for handling different kinds of seeds can be quickly made. All working parts are in full view of the operator. Just as an instance take the lubrication of a Case machine.

By means of steel compression cups for hard oil and

## Many More Features

large cylinder oil cups, which are raised above the pulleys, all parts can be lubricated while the machine is in full motion. In fact, all bearings and working parts are easy to get at.

Built entirely of steel the Case is a safeguard against the fires that play havoc with the wooden machine. The loss of a machine in the busy season is not in the cost of the machine entirely. A greater loss is in a crippled earning power when the season is busiest. Then time means money. Case machines insure absolute protection against this danger. No other machine has so many features. No other machine has so many records. Case sells 3 machines to 1 of any other make. What better proof of Case supremacy?

Limited space does not permit of all the details. Get our catalog brimful of interesting information to farmers and threshermen. It gives all the facts. Your name on a post card brings it postpaid.

**J. I. CASE THRESHING MACHINE CO., Inc. 759 Liberty St. RACINE, WISCONSIN**

Canadian Branches: Winnipeg, Toronto, Calgary, Regina and Saskatoon.

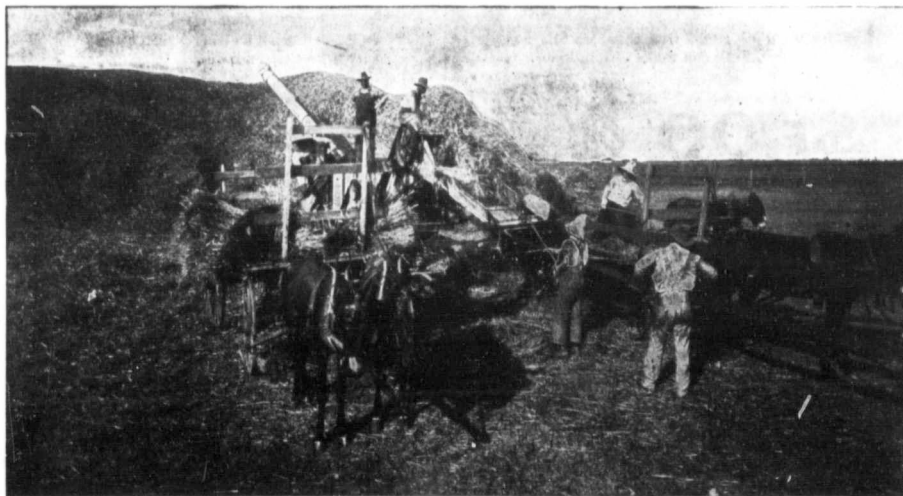

# REO

## Have You Ridden in the New Reo Six?

**IF YOU HAVEN'T** we think it is not too much to say you have yet to taste the real joys of motoring.

**AND WHEN YOU HAVE** ridden in this big luxurious equipage—the latest and in some respects, greatest product of Reo experience—you will understand why this car enjoys such a vogue—is so tremendously popular this season.

**REO SIX WAS PROCLAIMED** the "fashion plate for 1916" by designers generally from the moment its graceful lines were seen.

**AND DOUBTLESS YOU'VE OBSERVED** the influence this Sheer Line Reo has exerted on the design of seven passenger cars generally.

**BUT YOU MUST SEE IT**—must ride in and finally drive it yourself to fully appreciate what a magnificent car and what wonderful value it is at its price.

**AND THE CLOSER YOU STUDY** the details—the more carefully you enquire into every point of design, of construction, of quality of materials, of equipment and finish—the greater will be your admiration and the deeper your wonderment that it is possible to produce such a car for such a price.

**FOR YOU MUST KNOW** that this Reo Six is made as only the Reo Folk can make automobiles.

**IT IS REAL INSIDE AND OUT**—the Reo Folk do not use substitutes. Real leather in the upholstery and real hair.

**BUT THAT STATEMENT** is scarcely necessary. For you know the Reo Folk and you know Reo ideals. You know that Reo reputation is built on the most solid of foundations—a good product honestly made and honestly sold and honestly backed up afterward.

**AND THERE'S "QUANTITY" TOO**, if you like to put it that way. This is a big, full-size seven passenger car. Seats seven full grown adults comfortably—luxuriously.

**WHEELBASE IS 126 INCHES.** But that is increased—or rather the riding qualities are—to much more than it would otherwise amount by the Reo cantilever springs. They enhance the riding qualities of a car immeasurably—especially a big car like this New Reo Six.

**IF YOU APPRECIATE** the shortage there is going to be. If you want a Reo. And if you get us your order now—tomorrow—you will be one of the "lucky ones."

**BUT DON'T DELAY**—there won't be enough—never have been enough—Reos to go 'round.

Duty Paid **\$1700**  
*fab. Factory Leasing, Mich. U.S.A.*



(136-A)

REO MOTOR CAR COMPANY Lansing Mich.

Jus  
me  
ful,  
mol  
right  
  
Her  
Con  
31st  
Fari  
test  
deni  
first  
nun  
Nort  
mob  
Ligh  
Spee  
liver  
  
A  
  
w  
be  
su  
ge  
\$5  
we  
in  
Th  
mu  
en  
  
yo  
an  
to  
sul  
yes  
ent  
  
2  
pap  
mo  
ker  
Eve  
sub  
will

# This Handsome Car Free!

THE CHANCE  
OF A  
LIFETIME

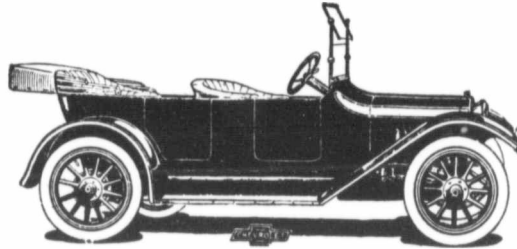

SEND IN YOUR  
ESTIMATES  
TO-DAY

Any Reader of The Canadian Thresherman and Farmer has a chance to win this

## 1916 CHEVROLET CAR

Just as sure as you are reading this announcement, you can be the possessor of this beautiful, powerful, speedy and comfortable automobile. All you have got to do is to get started right away in

### Our Fourth Wheat Estimating Contest

Here are the particulars:—

Commencing April 1st, 1916, and ending July 31st, 1916, the Canadian Thresherman and Farmer will carry on a Wheat Estimating Contest, open to everyone in Canada except residents of Winnipeg, and are giving away to the first person who estimates nearest to the number of Whole Kernels in 3¼ lbs. of No. 1 Northern Wheat, this \$725 Chevrolet automobile, all complete with Electric Starter and Lights, Mohair Top, Windshield, Ameter, Speedometer, Tools, etc. This car will be delivered to the winner F.O.B. Winnipeg.

### Read This Carefully

This is the fourth time we have put on a Wheat Estimating Contest, and the same general rules that have governed our former contests apply to the contest this year.

The wheat is a fair, clean sample of No. 1 Northern procured from the Dominion Government Grain Inspector's office, Winnipeg. The wheat and bottle were taken to the Dominion Weights' and Measures' office and exactly 3¼ lbs. of wheat weighed out and poured into the bottle, which was immediately sealed up in the presence of two witnesses. The bottle was then photographed and deposited with the Union Trust Company, Winnipeg, and will remain in their vaults until the contest closes, July 31st, 1916, when it will be taken out and counted by a board of three judges, none of whom are in any way connected with the Canadian Thresherman and Farmer.

Everyone who sends in a year's subscription for the Canadian Thresherman and Farmer, either new or renewal, is entitled to estimates

as explained below. These estimates may be credited in whatever way desired, and you may send in as many estimates as you wish. Remember, every additional estimate increases your chance to win the automobile. Estimate early and increase your chance of winning, for it is the first one that estimates nearest to the number of whole kernels that wins the car.

### Previous Contests

In the winter of 1908 we ran a contest as to the number of kernels there were in 15 lbs. of No. 1 Northern Wheat. When the contest closed it was found that there were 257,885 kernels in the bottle. In 1909 the number of kernels in 9 lbs. and 7-16 ozs. was 143,272, while in 1910 the number of kernels in 12 lbs. of No. 1 Northern Wheat was 197,543. With these facts to work upon you should be able to form an estimate as to the number of kernels in the bottle this year. Or better still, get some No. 1 Northern wheat yourself and count it out and form your estimate from that.

### A Good Plan

The number of estimates to which you are entitled may easily be increased by getting additional subscriptions. For instance, if you get five of your friends to send in \$5.00 in one envelope, each one would receive five estimates (or 25 in all) and a year's subscription. These five subscriptions, however, must come to us altogether in one envelope.

Do not delay. Start making up your list to-day because you have an equal chance with anyone else to win the car. Send in your own subscription for two, three or more years and get your neighbors to enter the contest also.

Neither the publishers of this paper, nor anyone else, know any more about the correct number of kernels in the jar than you do. Everyone has a chance to win. All subscriptions and estimates sent in will be acknowledged by letter.

### Estimates will be accepted as follows:

- 1 year's subscription at \$1.00 gives you 3 estimates.
- 2 years' subscription at \$1.50 gives you 7 estimates.
- 3 years' subscription at \$2.00 gives you 11 estimates.
- 4 years' subscription at \$2.50 gives you 15 estimates.
- 5 years' subscription at \$3.00 gives you 19 estimates.
- 6 years' subscription at \$3.50 gives you 23 estimates.
- 7 years' subscription at \$4.00 gives you 27 estimates.
- 8 years' subscription at \$4.50 gives you 31 estimates.
- 9 years' subscription at \$5.00 gives you 35 estimates.
- 10 years' subscription at \$5.50 gives you 40 estimates.

NOTE:—By taking out a subscription for more than one year you reap the benefit of a lower rate in addition to increasing your chance of winning the car by receiving more estimates. Subscribers who have already renewed their subscriptions may also enter the contest—their subscriptions being extended from the date they are due to expire

CONTEST CLOSES JULY 31st, 1916

Address all communications to

**E. H. Heath Co., Ltd.**  
Winnipeg Canada

E. H. Heath Co. Limited, Winnipeg.

Please find enclosed \$.....for.....years' subscription for the Canadian Thresherman and Farmer to be sent to

Name .....

Address .....Prov. ....

My estimates as to the number of whole kernels in 3¼ lbs. No. 1

Northern Wheat are:.....

If more space is required for names and estimates, use a blank sheet and attach securely to this coupon.



This is a photograph of the actual bottle of wheat after it had been weighed and sealed. The cut shows it considerably reduced in size.



THE PREMIER COMPANY  
THE PREMIER GOODS

WINNER OF GOLD MEDAL  
AT WINNIPEG

MADE IN CANADA

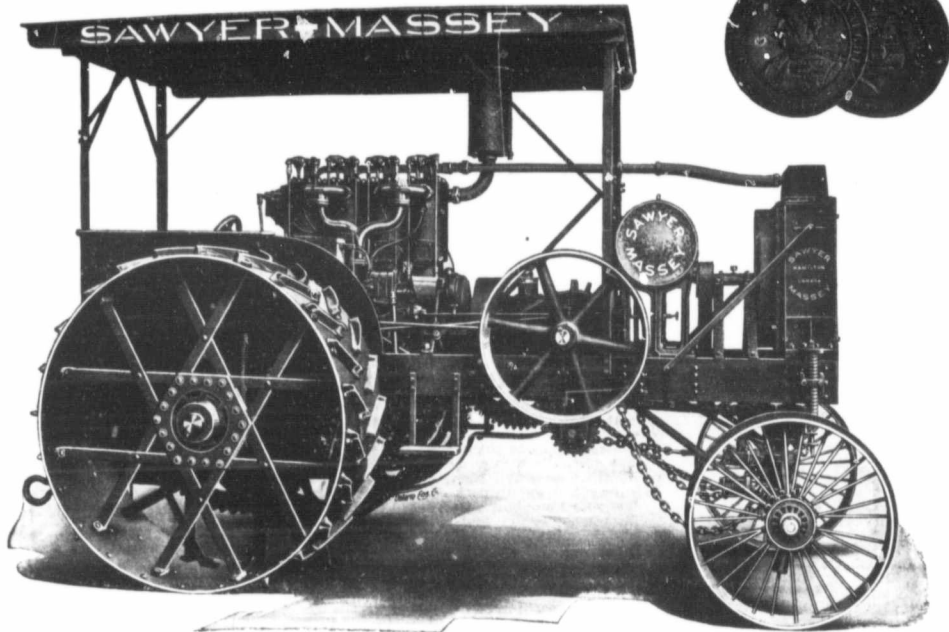

## THE POWER FOR ALL USES

During the last few years the Gas Tractor has made wonderful strides in popularity with the Canadian farmer.

And why shouldn't it? Gasoline drives his pump, his feed-cutter, his sawmill and his other small machines. It drives the automobile in which he goes to town in a fraction of the time it used to take. In every paper he reads, the news from the war is full of the part taken by the automobile and trucks, all gasoline driven.

The Gas Tractor for plowing, threshing and other heavy power used on the farm is naturally the next step after the small stationary engine and the automobile. A new and comparatively unknown machine a few years ago, its utility and superiority are now proven to everyone who has kept in touch with the power demonstrations, or better still, has had actual experience of his own with one of these machines. They are long past the experimental stage; they are now tried and proven the best.

The Sawyer-Massey Company has done its part in perfecting the Gas Tractor—in fact it has been a leader. The Sawyer-Massey "Gold Medal" Tractor is known in every part of the Dominion. Its reputation is everywhere the best, not only the cheapest form of power but the most dependable, cleanest and most satisfactory.

In planning to buy a machine this year, look around for the owner of a Sawyer-Massey "27-50" and ask him how he likes it. Write for our big Gas Tractor Catalogue and learn for yourself the particulars

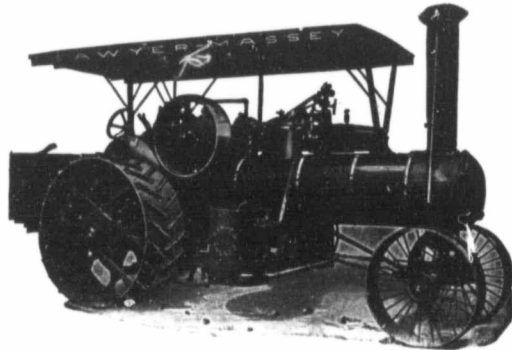

## SAWYER-MASSEY COMPANY, Limited

*Builders of Steam and Gas Tractors, Threshers and Road-making Machinery*

Head Office and Factory **HAMILTON, CANADA**  
Branch Offices and Warehouses: **WINNIPEG, Manitoba; REGINA, Saskatchewan;**  
**CALGARY, Alberta; Agency, BUENOS AIRES, Argentina**

# SAWYER-MASSEY

Ma

□

S  
E  
  
I  
gas  
size  
in  
ten  
way  
have  
rece  
pan  
  
W  
ter  
tw  
an

Get a  
better  
of gr  
stops  
impos  
We h  
Canv  
both i  
Madis  
gasoli  
Flue  
Wash

T

*The Maytag-Ruth  
Produces Results  
mechanically im-  
possible to any  
other Self-Feeder.*

# RUTH

The Self-Feeder with an Established Reputation

*The Self-Feeder  
Without a Single  
Fault, and with  
no Wear-Out to it.*

*It never Slugs a Cylinder---Never  
Clogs---Never Bends or Breaks  
a Tooth---Lasts Practically  
a Life Time.*

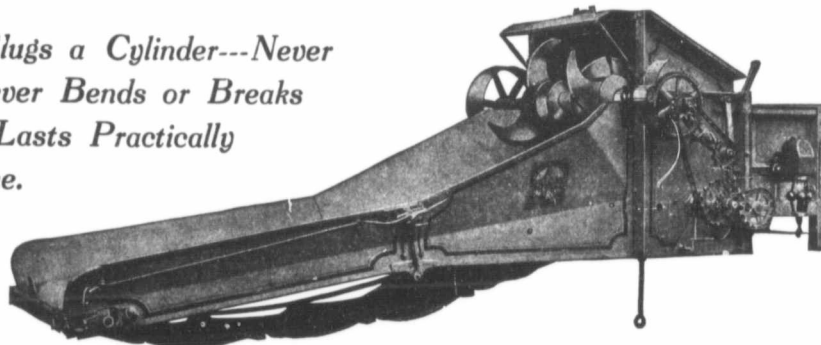

## Maytag-Ruth SELF-FEEDER

*The Fastest, Cleanest, Best and Most Economical Feeder in the World*

### STRONGEST GUARANTEE EVER GIVEN WITH ANY SELF-FEEDER

Such faith have we in the Maytag Ruth Feeder that we guarantee every Maytag Ruth Feeder to feed any make or size of separator to its full capacity, with any kind of grain in any condition whatsoever bound, loose, straight, tangled, stack burned, wet or dry, piled on the carrier any way you please—without slugging the separator cylinder or loosening a spike, and do a faster, cleaner and better job of feeding than any feeder manufactured by any other company in the world.

We mean this guarantee to the full extent of our reputation, gained after twenty years of fair and square dealing and big value giving.

The Maytag Ruth *stands up* under your work—under the heaviest work. Buy a Maytag Ruth with absolute confidence that it will save grain for you—that it will save money for you—that it will save time for you. There are no delays over mechanical troubles. **THE MAYTAG RUTH CANNOT SHAKE ITSELF TO PIECES**—it prolongs the life of your entire outfit indefinitely.

The Maytag Ruth feeds perfectly. Every band is cut and every bundle is thoroughly loosened up and pulled apart before it can pass to the separator cylinder. The grain is fed to the separator high on the threshing cylinder with no opportunity for it to lodge in front of the cylinder.

### Write Us for Big Colored Circular

Get all of the facts—the full description and illustration of each part. You will then see how and why the Maytag does more and better work—how it accurately regulates the flow of the grain, the throat may be contracted or expanded so that the right amount of grain is always fed—how the retarder and feeding cylinder are controlled by the Pickering Governor that operates a trip lever that stops the raddle until the feeding cylinder has disposed of the grain, maintaining an even flow of grain constantly, rendering clogging impossible at any and all times.

We handle everything that a Thresherman uses except Separators and Traction Engines. All kinds of Oils and Greases—Rubber and Canvas Endless Drive Belts—Canvas-covered, Plain and Solid Rubber Suction Hose—Suction and Discharge Hose—Lace, Leather, both in the hide and cut, put up in one-pound boxes—Canvas and Rubber Belting in any length needed—Pulley Lagging—Full line of Madison-Kipp Lubricators and Oil Pumps—Tank Pumps—Gasoline Pumps and Hose for same (this pump is used for pumping oil or gasoline)—Headlights for Traction Engines—Belt Guides—Morris Improved Beading Tool—Barth Lifting Jacks—Adjustable Inside Flue Cutters—Flue Cleaners—Spark Arrestors—Cylinder Wrenches—The Best Power Washing Machine in the World—The Best Hand Washer Ever Made.

*Do not put off writing for Ruth Feeder Information*

**The Maytag Company, Ltd., WINNIPEG,  
MAN.**

# HOW THE WORLD IS FED

**U**NDER normal conditions there is a wealth of interest in the feeding of a great population of human beings. At the present moment the subject opens up a field for contemplation that has no parallel or precedent in human history.

As we write, two great empires numbering roughly a hundred million souls are being threatened with starvation. For several generations, with the exception of one or two scraps "in the Balkans," the central powers have lived at peace with all the world. The high seas were as free to them as the air currents are to the feathered creatures; every mart and stronghold of the world was open to them and the courtesies of life were punctiliously tendered them at every port of entry.

These friendly tokens were not simulated. They were sincere, spontaneous, and handed out with a generosity and trustfulness that knew no qualification. But the war dogs of the central powers slipped their collars, and soon all hell was loosened. A few degenerates of the Prussian oligarchy and of the ill-fated Hapsburg crew are the instigators of the whole mischief but the people of the central empires have to bear the brunt of all that it means in sacrifice.

Meanwhile that worst of all war's horrors (famine) is beginning to raise its head. Storm, stratagem, blockade have been brought into play, and the avenues of supply that these beleaguered millions have hitherto depended

upon are being relentlessly sealed off by impassable barriers. All this has had the effect of dislocating and revolutionizing the whole economy of the world's food supply. It is therefore a matter of the deepest concern that we should

take an inventory of the world's market basket, see what effect war has had on the world's food supply in the past, what effect it is having to-day and if possible make some forecast as to its effect upon the future of our own part in that food supply.

For much of the data that will follow, as well as the very striking illustrations we are indebted to an exhaustive article by William Joseph Showalter, under the above caption in a recent issue of the National Geographic Magazine. Mr. Showalter points out that if we go back one hundred years, we will find that France was facing almost the same problem that Germany and Austria-Hungary are facing to-day. England's warships blockaded the French ports then just as the British fleet is blockading Germany's to-day, and over-sea foodstuffs had little chance to find their way into France.

How far this went, and how great an effect it had on conditions in Napoleon's empire, is revealed by the fact that sugar sold for two dollars a pound. And that the world is not sugar-hungry to-day is due to the steps taken by Napoleon to overcome the effect of the blockade on sugar. Years before, some Prussian scientists had been trying to get sugar from the beet, and under the patronage of the King of Prussia, succeeded in their task.

Napoleon borrowed their ideas, set up beet-sugar factories around Lille and gave to the sugar-beet industry that impetus which has resulted in its development to a

point where it yields half of the world's supply of sugar.

### War and Canned Goods

The Little Corporal saw himself seriously embarrassed in the matter of food supplies for his army. He wanted something for his men



Sowing Rice Broadcast: Siam

besides things that were dried or smoked — a desire that was enhanced by his knowledge that millions of dollars in valuable but perishable foods were wasted because of the lack of adequate means of preserving them.

He therefore offered a prize of twelve thousand francs to any one who would devise a practicable method of preserving such foodstuffs. Such a method was quickly evolved, and out of it has grown the world's canning industry—one of the important steps that civilization has taken in the direction of insuring mankind against famine. It is not impracticable that the present war will bring to mankind new methods in the feeding of the race that will prove as important as those brought out by the Napoleonic wars. It has been announced lately that the Germans have devised a new synthetic method of producing protein. It is said that they feed yeast with a combination of sugar and nitrogen from the air, and thus secure that most important of all of the elements that enter into the world's diet—protein. Examples of protein are the whites of eggs, the muscles of meats, the casein of milk, the gluten of flour, and the nitrogenous fats.

It may also happen that as a result of the war will come the utilization of other plant products than those now entering into direct use as human food. There are approximately half a million species of plants in the world, and yet only a few thousand of them are used at all for food, while only a few hundred of these are used to any important extent. Some of the plants which we now grow are expensive food-producers, some produce food that is difficult to

digest, and some give a small yield per acre.

### Developing New Foods

We are constantly developing new foods. It is only little more than half a century since the tomato was a curiosity of the

South, known as the "love apple," and used to scare the slaves who thought it poisonous. Corn came to us from the Indians, and has become one of the leading cereal crops of the world. It is less than a century ago that the lima bean came to us from South America, and the potato was unknown to civilization before the white man went to Peru and Colombia. To-day representatives of all of the leading nations are scouring the remote places of the earth for crops which promise to increase the world's total yield of food, as well as its per-acre production.

### Fruits and Vegetables Have Been Wonderfully Improved

Not only is mankind gradually increasing the possible acreage for the growing of foodstuffs—and statistics indicate that only the most fertile of the world's potential food-producing acreage is under cultivation today—but the crops themselves are being constantly improved and their natural per-acre yield increased.

### What of the Future?

Many men are inclined to sound a pessimistic note as to the adequacy of the world's food supply for future generations, and, like Malthus a hundred years ago, are inclined to predict that the day has at last come when the human race must cease to expand its numbers, or else face inevitable hunger. And when we consider how many mouths there are in this world to feed, and how much food



Bringing in the Potato Crop: Near Nairobi, East Africa

wealth of the richest nations pay the twenty-six cents per day per of living \$6,000,000,

average probably of provisions allowed. Even the jail gets Russian the Aust pounds a Still a of the size lem is to individual worth of it world

Exp consum basket in weigh to east measur of its p the ave uses tw day, th amount tons. I cars, ea car an around terial.

The average probably of provisions allowed. Even the jail gets Russian the Aust pounds a Still a of the size lem is to individual worth of it world





it takes to satisfy them, little room is there to wonder at this note of pessimism.

The earth's population to-day reaches a grand total of about 1,700,000,000 souls. If they were all set down at a banquet it would require sixteen tables reaching around the globe to seat them. For every ounce of food they ate, the dinner-giver would have to provide 53,000 tons of provisions, and if the dinner were no more than a democratic dollar-a-plate affair it would cost, in the aggregate, as much as it costs to run the United States government a year and a half.

Expressed in terms of annual consumption, the world's market basket is one that defies portrayal in weight and size. One is forced to cast around for new units of measurement to give a proper idea of its proportions. Assuming that the average inhabitant of the earth uses two pounds of provisions a day, the total for the year would amount to a billion and a quarter tons. It would require a string of cars, carrying thirty tons to the car and reaching eight times around the earth, to haul this material.

The Average Ration

The fact, however, is that the average inhabitant of the earth probably uses more than 2 pounds of provisions a day. The steerage passengers on English ships are allowed 2 1/2 pounds each a day. Even the prisoner in the average jail gets more than 2 pounds; the Russian conscript 4 pounds; and the Austrian common soldier 2 1/2 pounds a day.

Still another way to get an idea of the size of the world's food problem is to assume that the average individual consumes ten cents' worth of food daily. On this basis it would require the entire national

world's annual market-basket expense.

Starvation Still Remote

But when one considers the possibilities of future food production, it is difficult to have much faith in the prophecies of pessimism of these twentieth-century Malthus.

For instance, in the United States we have 935,000,000 acres of arable land, only 400,000,000 of which are under cultivation. Yet, with less than half of our available land utilized, the United States produces one-sixth of the world's wheat, four-ninths of its corn, one-fourth of its oats, one-eighth of its cattle, one-third of its hogs, and one-twelfth of its sheep.

Even with the land now under cultivation, if we produced as much wheat per acre as England and Germany, we could supply the world with two-thirds of its flour. If we produced as much corn to the acres as they do, we could double the world's supply of that product.

To-day the United States has a total cereal crop of 5,000,000,000 bushels. Were all of our arable land under cultivation and producing only according to our present standard, which is less than half as high as that of western Europe we could add enough cereals to take care of an additional population the size of that of Europe.

Little Room for Pessimism

When one has lived on land, which, at the end of the American Civil War, did not produce more than eight bushels of wheat and twenty bushels of corn to the acre, and has seen this land produce as high as forty-five bushels of wheat and a hundred bushels of corn, it is difficult to take any other than an optimistic view of the possibilities of American agriculture.

producing possibilities such as few other countries possess, has a wheat yield of only ten bushels to the acre.

When the day comes, as come it certainly will, that Russia produces as much per acre as Germany and England, and when the untold millions of acres of undeveloped land are opened up and

River valley, were producing millions of bunches of bananas, where but a few years before had existed the same sort of jungle as that at Quirigua.

New Products Available

Not only are there vast millions of acres of potentially rich agricultural lands still awaiting development, and not only is it cer-



Low-Priced Fish for High-Priced Beef—Frozen Halibut

settled, as they are destined to be, alone she can supply the world's present needs in cereals except rice and corn.

Tropical Possibilities

Nor is that all. Any one who has travelled through the tropics, studying the production of food-stuffs there at first hand, cannot fail to understand that vast potential food sources still lie untouched. The wonderful discoveries of Ross and Reed and their coadjutors, of the methods of preventing malaria and yellow fever, followed by the mastery of the secrets of the Bubonic plague and beriberi, and the application of these lessons in Cuba, at Panama, and elsewhere in the tropical world, have made it possible for civilized man to open up gardens of plenty of which he never before dreamed.

Untold millions of acres of densest jungles are, so far as man is concerned, nothing more than lands of infinite richness wasting their sweetness upon the desert air of unutilized opportunities.

Not long ago the writer of this article visited the ruins of Quirigua, in Guatemala. The United Fruit Company had set apart several hundred acres as a reservation for the protection of the ruins. The jungle forest of the reservation, bordering the banana clearings, towered like a green wall a hundred feet high, and the undergrowth was so dense that no man could penetrate it save by cutting his way through with a hatchet.

There he saw the contrast between the past and the future of the tropical world. The banana plantations, stretching for miles and miles up and down the Motaga

tain that the production per acre of those lands now under cultivation will be vastly increased, but new products are an inevitable prospect of the future.

When one travels in tropical countries he finds that banana flour makes an excellent substitute for wheat flour; and if the day ever comes when the wheat and the rye and the barley crops do not yield sufficient bread, there are hundreds of millions of acres of potential banana land which will produce many-fold as much banana flour to the acre as we are able to get to-day of wheat flour from our wheat lands.

One might go on at length showing the wonderful possibilities of agriculture that lie in the future. Even if there should be no other developments than those which, by experience alone, we are able to forecast, there is no question but that the prospect of the world's starvation is to all practical purposes as remote as it was in the days of the pessimistic Malthus.

But just as the forecasts of Malthus failed to consider the possibilities of the age of agricultural machinery, the age of commercial fertilizer, and the age of preventive medicine as applied to live stock, so it is probable that the prophets who predict a hungry world in the not-distant future are failing to reckon with the possibilities of further extension and improvement of agricultural conditions.

Continued in June issue.

FOR DINNER

Little Fred—I'm awfully hungry. I didn't get half enough dinner. Little Susie—What did you have for dinner? Little Fred—Why, we had company.

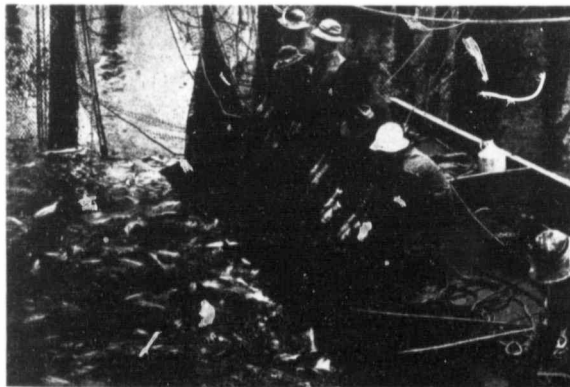

A Profitable Haul From a Source That Has no Limit

wealth of the United States, the richest nation of all history, to pay the world's food bill for twenty-six months. For every cent per day per capita that the cost of living increases, more than 80,000,000,000 is added to the

Not only are there infinite possibilities yet untouched in our own country, but also in most of the other countries of the earth as well. For instance, Russia, that land for which nature has done so much, endowing it with food

y, '16  
3333  
3333  
all yield  
ods  
veloping  
the more  
nce the  
of the  
pple,"  
s who  
came  
id has  
cereals  
s than  
a bean  
merica.  
wn to  
e man  
all of  
uring  
th for  
crease  
od, as  
Been  
ually  
e for  
—and  
the  
ntial  
nder  
crops  
antly  
per-  
bund  
ade-  
pply  
like  
are  
has  
race  
ers.  
how  
this  
food

THE CANADIAN THRESHERMAN AND FARMER

CANADA'S LEADING AGRICULTURAL MAGAZINE

E. H. HEATH, PRESIDENT

E. W. HAMILTON, MANAGING DIRECTOR

F. C. BRAY, TREASURER

PUBLISHED MONTHLY BY



E. H. HEATH COMPANY, Limited, WINNIPEG, CANADA



J. D. DUTHIE, EDITOR

U.S. Representative—JAS. A. SUCHANAN 1313 MARQUETTE BLDG. CHICAGO, ILL.

(MEMBER WESTERN CANADA PRESS ASSOCIATION)

AUTHORIZED BY THE POSTMASTER GENERAL, OTTAWA, CANADA, FOR TRANSMISSION AS SECOND CLASS MATTER

May

1916

OUR RETURNING SOLDIERS

OUR GUARANTEE

No advertisement is allowed in our Columns until we are satisfied that the advertiser is absolutely reliable and that any subscriber can safely do business with him. If any subscriber is defrauded R. H. Heath Co., Ltd., will make good the loss resulting therefrom. If the event takes place within 30 days of date advertisement appeared, and complaint is made to us in writing with proofs, not later than ten days after its occurring, and provided, also, the subscriber in writing to the advertiser, stated that his advertisement was seen in "The Canadian Thresherman and Farmer." Be careful when writing an advertiser to say that you saw the advertisement in "The Canadian Thresherman and Farmer."

HOW long this war will last or how suddenly it will collapse no one can divine. Not even the best informed of the nine thousand odd full blown "field marshals" of our city can forecast the future so much as to one day's operations. But to those of us who are compelled or have chosen to "abide by the stuff" and let our office mates and the sons of our next-door-neighbor do the fighting, there are certain duties that we cannot neglect and there are services we can render to the state which are second in importance only to those of the brave men who are making it their sole business to get at the throat of the

FIRE.

At the most awkward time such a disaster could have happened, a large portion of our May issue was burned in the fire which occurred in the Stovel Block, Winnipeg, on the night of May 1st. Thirty-two complete pages, together with a large number of oddments went up in smoke or into the melting pot. This fact will explain the lateness of our appearance as well as possible errors and omissions which we had no means of checking.

We beg the indulgence of our readers and advertisers under the circumstances. But for the extreme courtesy of all of our local contemporaries in helping us to certain copy which could not be reproduced or replaced at short notice, we would have been in a worse plight. To these we send a grateful message and beg to assure our friends that we will be on deck to time with next and following issues.

E. H. HEATH CO., LTD.

coming home in dribblets now, but by and by they will arrive in whole battalions and in quicker succession than they were sent away. The historians all agree that one of the most remarkable features of that fine citizen army of the Commonwealth was the wonderful way in which,

having done its part in the great liberation war of that day, it peacefully, naturally and quickly returned to the old employments of civil life.

"No man swore or got drunk, but every man paid his twelvecence in the shilling." What a fine testimony to a nation's fighting manhood! Let us smug, sanctimonious, stay-at-homes see to it that as the boys come home the beds are well aired; that there are no cold shoulders or stiff necks; that "the glad hand" is not a clammy one when it is held out to welcome them back. We sent them away with the solemn assurance that the care of their beloved ones in their absence would be our unremitting concern, and that their own interests would take precedence of all "birds of passage" on their return to the old circle of boon companionship or busi-

SUBSCRIPTION RATES

Postage prepaid, Canada and Great Britain, \$1.00 Per Year. Single copies 15 cents. Postage prepaid, United States and Foreign Countries, \$1.50 Per Year.

Failing to receive paper, you should notify the office at once, when mistakes, if any, will be corrected immediately. All Subscriptions must be paid for in advance and no subscription will be accepted for a shorter period than six months.

Advertising copy in order to secure good position should be in our hands not later than the 15th of the month preceding date of issue.

Advertising rates furnished on application.

enemy. These have to do with the re-absorption into civil life of what are left of those 300,000 gallant fellows who have given up every other employment to handle the rifle and machine gun.

Mere words fail to express the pride we feel in that splendid army of our sons and brothers and old playground chums who are now singing in the trenches their part in the grand anthem of Liberation, dying, many of them every day, with the song of victory on their lips. Those wonderful platoons of Canada's new citizen soldiers who marched through the streets of Winnipeg on "Decoration Sunday" called up a picture of those 80,000 grim Ironsides "that farmer fellow Cromwell" led through the streets of London on one other memorable May-day—"the best army the world has ever known, soldiers whose back no enemy had ever seen," said Lord Wolseley.

The end is in sight but in the blur of the battle smoke we yet fail to judge the distance between us and the goal. But however far off it may be there will come a day when the bugle call to "Cease firing" will shatter the nerves of some people quite as effectively as did the declaration of war. Already, maimed and limping comrades are returning to us, having done their bit and are no longer fit to return to their place in the ranks of the effectives. They are

ness associations.

Our character is at stake in the way we handle these men. Apart from our moral obligations, there is a big problem on the economic side of this subject which every one has something to do with, and its solution need not be postponed until peace has been declared. One thing must never be overlooked; not one of these brave men must be disappointed in a single promise that was made him before he left. Our battle-scarred soldiers have to take precedence of all else in the matter of employment—conditional only on their good behaviour. But no man of dissipated habits shall presume on this. Here is where much real heart-ache is likely to find its seat. Broadly the returned soldier has nothing to apprehend as to the constancy of his compatriots—if he is but true to himself. There is a solid job and a world of kindness awaiting every "sober chiel" who went out to fight for Canada's national existence.

# The kind of a Guarantee to get with your Tractor

Form 7-NORTHERN-25M-11-15

## ORDER FOR MACHINERY

Dated March 20 1916

ADVANCE-RUMELY THRESHER COMPANY, Inc., having its Head Office at LaPorte, Indiana, herein called the Vendor, hereby requested by the undersigned, herein called the Purchaser, to deliver to the Purchaser at the place of shipment, on or about the 3rd day of April, 1916, (or as soon thereafter as it can do so), and ship the same to Wagner, R. R. Station, Mont. State of Mont.

the following machinery with usual fixtures and extras hereby now agreed to be purchased from Vendor, upon which the Purchaser agrees to pay all freight and charges from Factory via Billings to Wagner.

said machinery to be kept in \_\_\_\_\_ Township, \_\_\_\_\_ County State of Mont.

**ENGINE**  
ONE \_\_\_\_\_ H. P. \_\_\_\_\_ CYLINDER \_\_\_\_\_ BURNER \_\_\_\_\_ Threshing—Flaw—General Purpose \_\_\_\_\_ TRACTION ENGINE \_\_\_\_\_

**SEPR**  
ONE \_\_\_\_\_ SEPARATOR \_\_\_\_\_ INCH \_\_\_\_\_ INCH REAR \_\_\_\_\_ To be Driven by a \_\_\_\_\_ H. P. Engine \_\_\_\_\_ Having a \_\_\_\_\_ Fly Wheel, running \_\_\_\_\_ Rev. per Minute \_\_\_\_\_

**STACHER**  
ONE \_\_\_\_\_ STACHER FOR \_\_\_\_\_ Hopper-Separator-Huller \_\_\_\_\_ If Wind or Sattley \_\_\_\_\_ If \_\_\_\_\_ that the price, if on time, is \$ \_\_\_\_\_ to be settled for \_\_\_\_\_ rate equal notes \_\_\_\_\_ If cash, \$ \_\_\_\_\_

**TRACTOR**  
ONE Oil Pull RATED 15 TRACTIVE H. P. 30 \_\_\_\_\_ WEIGHER WITH \_\_\_\_\_ ATT'M'T \_\_\_\_\_

**MISC.**  
ALSO FURNISH \_\_\_\_\_ with \_\_\_\_\_

**Written Guarantee or Word of Mouth Promises?**

Every Oil Pull order carries this printed guarantee. Insist that the order for the tractor you buy carries the same guarantee in writing.

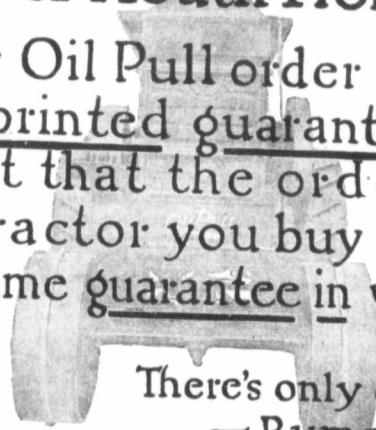

There's only one Oil Pull  
— Rumely Laporte

Accepted at LaPorte, Ind., this Third day of April 1916

ADVANCE-RUMELY THRESHER COMPANY, Inc.  
By M.C.A.

MY POST OFFICE IS	R. R. NO.	STATE	TOWNSHIP	COUNTY	SIGN BELOW
<u>Wagner</u>		<u>Mont</u>		<u>Phillips</u>	All parties to this order and agent must sign it.
				<u>Steve Holman</u>	(Seal)
					(Seal)
					(Seal)

# PRACTICAL TALKS TO THRESHERMEN

**LESSON CXII.**

**F**ROM the discussion presented in the last lesson it is clearly evident that side draft in plowing can only be eliminated when the tractor is designed to pull a definite number of plows. If it is made for only two plows it must of necessity be very narrow—too narrow, in fact, to be practical. It is not until four plows are used that a tractor of standard road width can be employed.

There are other factors that enter into tractor design that are frequently overlooked and these are the effect of wheel base and distribution of weight. Referring back to Figure 247 in the last lesson, it is shown that the force at the front wheels tending to pull them around amounts to 150 pounds. This is figured on a wheel base of one hundred inches. But if, instead of one hundred inches, we decide upon a wheel base of eighty-four inches one of the lever arms is thereby shortened and the force at the front axle tending to deflect the wheels out of their course is increased to 188 pounds. It is therefore clearly evident that as we shorten the wheel base we increase the evils of side draft.

The requirements of small fields and old land cultivation generally demand tractors of short wheel base in order to make short turns on the head lands and around obstacles. The requirements of nimbleness and working efficiency make the short wheel base a necessity. In consequence of this requirement, it is vitally necessary to distribute the weight between the front and rear axles in such a manner that there shall be enough weight on the front wheels to successfully resist the side draft.

In order to discover the effect of both side draft and distribution of weight, let us investigate the requirements of a light weight, four wheel tractor having the following dimensions and designed to haul two plows:

Wheel base .....	84 inches
Total Width .....	54 inches
Height of drivers .....	60 inches
Weight .....	3,500 pounds

We shall first compute the maximum probable side draft and then determine the distribution of weight.

Allowing four inches between the edge of the furrow and the furrow drive wheel, we find the

center of traction is thirty-one inches from the furrow. The center line of draft of the plows is nineteen inches from the furrow. The difference of twelve inches is the length of the lever arm which tends to pull the front wheels toward the right. Assuming that the maximum draft of the plows is 1,400 pounds, and knowing that the wheel base is eighty-four inches, we have:  $1400 \times 12 = 84 \times F$ .

Solving this equation we find that the force F which may act on the front axle to swerve it from its course is 200 pounds. On the

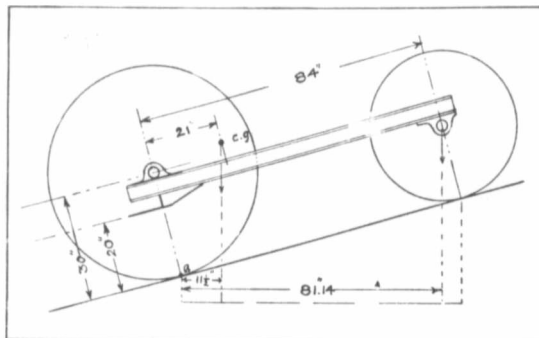

average it will probably amount to about 140 pounds. If the wheel base were ninety-six inches these figures would be reduced to 175 and  $112\frac{1}{2}$  respectively, thus proving that the longer the wheel base the smaller will be the value of the deflecting force on the front wheels.

Since there is a constant tendency for the front wheels to turn out of their course, it follows that the total weight of the machine must be so distributed that there will always be a greater weight on

the front wheels than the value of the deflecting force.

Figure 1 represents a skeleton view of the tractor under consideration. The point of draft is taken ten inches below the rear axle or twenty inches above the pivot point A. In making the necessary computations all we do is to take the sum of the moments about the point A. For convenience we will first assume that the entire weight of the machine is centered at some point called the center of gravity, c, g, in the figure. The distance x from

the rear axle to c, g, is unknown but can easily be found for the condition of balance. There are only two forces to consider, the weight of machine, 4,000 pounds, acting downward through the center of gravity, and the resistance of the load. The lever arm through which the load acts is twenty inches and that through which the weight of the machine acts about a we have:  $1,400 \times 20$  acts is to be found.

Taking the sum of the movements  $= 4,000 \times F$ . Whence  $F = 7$  inches.

That is, on perfectly level ground, it would be necessary to put the center of weight seven inches ahead of the rear axle to prevent the machine from tipping over backwards. But even if this were done there would be no weight on the front wheels and it would be impossible to steer the machine because of the side draft. Not only that but if the tractor pulled up a grade the center of gravity would shift farther back toward the rear axle and unless the load were greatly reduced it would tip over backwards. In the old steam tractor days it was thought necessary, in order to obtain traction, to put all the weight possible on the drivers and some machines had the center of gravity so far back that when they came to a hill they had to back up. With the plowing tractor, no one would tolerate a machine that is not stable under all conditions, that is why it is necessary to be so careful in the distribution of weight.

In light weight tractors it is customary to so distribute the weight that when the machine is standing still on level ground one-quarter of the total weight will rest on the front wheels. In the case of the tractor we are considering, there would be 1,000 pounds on the front wheels and 3,000 on the rear wheels. To obtain this condition the center of gravity, or point at which the machine would balance if set on a knife edge, will be twenty-one inches ahead of the rear axle; or one-quarter of the distance between the axles. With this distribution of the weight let us investigate and see how this is modified by the load.

We are now assuming that there is the equivalent of 1,000 pounds concentrated on the front axle. The lever arm through which this force acts about the pivot point a is eighty-four inches. The load of 1,400 pounds acts through a lever arm of twenty inches. The moment of the 1,000 pound weight about a is 84,000 and the moment of the 1,400 pound load about a is 28,000. One acts in one direction and the other in the opposite direction. The effect is to take a portion of the weight off the front wheels. Since the lifting up moment is just one-third of the moment that holds the front wheels down, it follows that the effect of the load

## Manitoba Thresherman

This space in a future issue will contain an

# ANNOUNCEMENT

that will be of vital importance to you. The announcement will undoubtedly appear in the June issue of this magazine, but in any case, be sure and watch for it.

## Stidolph and Nellerroe

SPECIAL AGENTS

Employers Liability Assurance Co.

220 Curry Block

Winnipeg, Manitoba

Continued on page 22

Y  
m

Beca  
quali  
on tr  
fore  
quali  
Tract  
in the  
a mo  
long  
stock  
force  
A larg  
it con  
magne  
gasolin  
tracto

Y  
your o  
man-T  
It cost

The

Minne

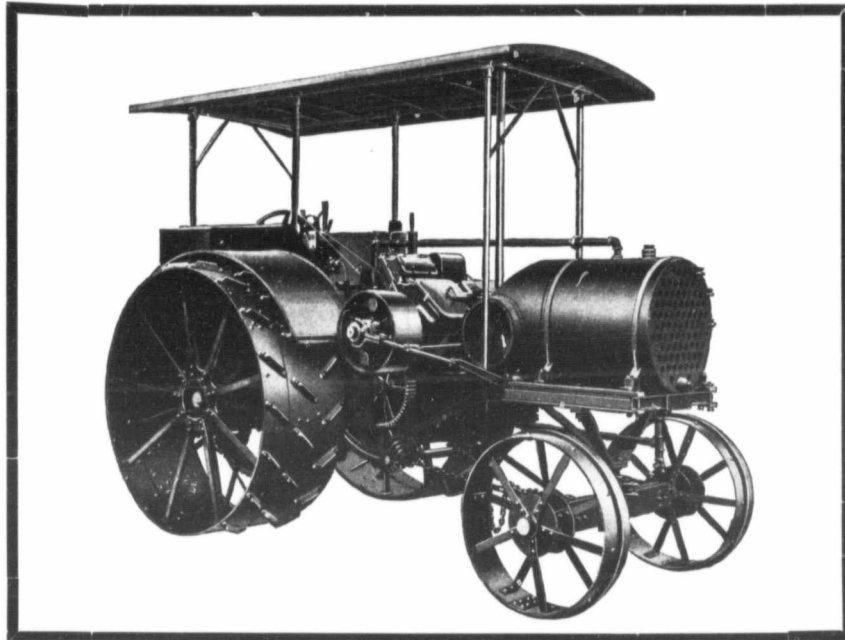

**You Hear the Name "AULTMAN-TAYLOR"**  
**mentioned whenever reference is made to Tractors**  
**WHY?**

Because Aultman-Taylor Tractors are tractors extraordinary—the standard by which all other tractors are judged. Their good qualities, and they have many, have earned for them a prominence in the tractor world that is the envy of all—but one not posted on tractor construction might ask the reason for this pre-eminence—this overwhelming supremacy. It's easily explained, but before going further, get this firmly fixed in your mind: Aultman-Taylor Tractors are quality tractors—built in a factory where quality, rather than quantity production prevails. Then take up the details of construction, one by one. All Aultman-Taylor Tractors are equipped with big, four cylinder, valve-in-the-head motors—the last word in tractor motor development. The valves in the heads insure the utmost power from every unit of fuel expended; quick, economical, responsive power every minute, and a more accessible motor was never built. Wide faced, straight spur gear transmission protects you against big repair bills and long delays. The locomotive truss frame is a marvel of strength, made of heavy steel bars. These heavy steel bars afford ample stock for receiving the bolts. No shearing of bolts—no broken-down frames. A very strong, light and flexible frame. Multiple force feed oil pumps take care of lubrication in great style. Each bearing, cylinder and gear is properly lubricated at all times. A large closed radiator cools the engine in the hottest weather, and every provision is made for drainage. And when it comes to control—nothing like an Aultman-Taylor—most any boy can operate it. One lever does it all. A Bosch magneto and batteries take care of the ignition in excellent shape. All A. & T. tractors are equipped for using gasoline, kerosene and distillate. Large, wide drivers enable A. & T. Tractors to pass over soft ground, where many other tractors would mire. Numerous other features of the utmost importance are to be found in Aultman-Taylor Tractors.

You want to know more about the most popular line of tractors on the market. For your own sake, sit down to-day and WRITE FOR CATALOG. It tells you how Aultman-Taylor Tractors are built from start to finish. Write us to-day for full information. It costs you nothing to get this information.

**The Aultman & Taylor Machinery Company**

**Lock Box No. 64, Mansfield, Ohio**

**BRANCHES:**

**Minneapolis, Minn. ; Great Falls, Mont. ; Regina, Sask. ; Calgary, Alta., Canada**

**TRACTOR COUPON**

(64)

I am interested in your Gasoline-Kerosene Tractors and desire information on size herein checked:

18-36     25-50     30-60

NAME .....

ADDRESS .....

.....

ound,  
 at the  
 nches  
 event  
 over  
 were  
 ht on  
 ld be  
 chine  
 Not  
 ulled  
 avity  
 ward  
 load  
 ld tip  
 steam  
 eces-  
 tion.  
 le on  
 hines  
 o far  
 a  
 With  
 ould  
 not  
 at is  
 care-  
 ght.  
 it is  
 the  
 ne is  
 one-  
 will  
 the  
 con-  
 1,000  
 and  
 ob-  
 r of  
 ma-  
 on a  
 -one  
 ; or  
 be-  
 dis-  
 s in-  
 is is  
 that  
 .000  
 ront  
 ough  
 the  
 hes  
 acts  
 enty  
 ,000  
 ,000  
 ,400  
 One  
 ther  
 The  
 the  
 eels  
 just  
 that  
 t, it  
 load

### Lightning Protection on the Farm

With References and Quotations from Prominent Authorities  
By W. E. Clark

THE enormous loss due to the destruction of buildings by fire and lightning each year is occasioning much comment, and strenuous efforts are being put forth to minimize this loss. It is estimated that the fire and lightning loss in the United States and Canada for the past year is \$254,000,000 which means an average

shoulders cuts down individual liabilities for large amounts, does not in any way alter the situation. Every individual in Canada loses \$3.50 per year on account of fire and lightning losses, whereas in Europe the per capita loss is only 48c; there they make every effort to prevent the fire, on this continent we try to extinguish it;

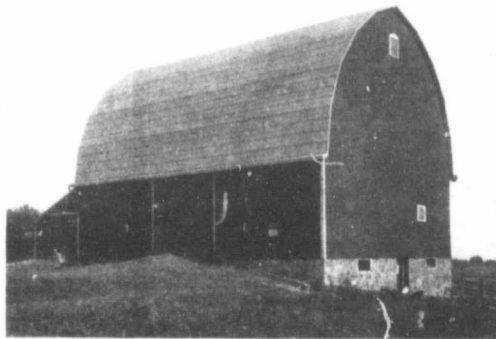

loss of \$700,000 every day. In Canada alone the loss is \$26,000,000 annually.

In the cities restrictions are being adopted making it impossible to build the easily combustible structure which has flourished in the past; in all modern cities fire districts are laid out, and combustible structures are forbidden within the limits of these districts. In addition, outside these business districts, the tendency is to discourage by Legislation the building of residences or any other structures unless same are largely protected against fire from outside influences.

there they figure that a fire is an absolute loss of money, here we consider it an exchange of our property for ready money. This, in general is the situation as pertaining to cities, towns and villages. It is indeed serious, and worthy of the best efforts of the Dominion and Provincial Governments to minimize the loss.

Attention is called to a much more serious phase of the matter, viz, unprotected condition of farm buildings as compared with those in the city where fire protection and fire extinguishing are receiving increasing consideration. The average building is an easy prey



There is a tendency to regard a fire loss lightly, due to the fact that insurance minimizes the individual loss. As a matter of fact every dollars' worth of property burned up is irretrievably and for ever lost, and is a burden on the community at large just the same as a tax.

The fact that banding together and thus reducing the risk by transferring it to other and distant

to the flames, once they are started. It is almost impossible for the farmer to arrange for capable fire fighting facilities so that he must look to prevention rather than means of extinguishing the fire. Fire once started in a farm building, either a residence or an out-building rapidly gains headway and before the meagre fire-fighting facilities can be put in operation, has gone beyond the

# WHITE ROSE Motor Gasoline

Develops more power with less carbon than any other. Ask us for prices on this and on

- LILY WHITE ENGINE KEROSENE
- NATIONAL CARBONLESS MOTOR OIL
- BLACK BEAUTY AXLE GREASE
- NATIONAL TRACTOR DISTILLATE
- NATIONAL HARVESTER OIL
- NATIONAL GAS ENGINE OIL, Etc.

MADE IN CANADA AND FOR SALE BY

## CANADIAN OIL COMPANIES LIMITED

WINNIPEG BRANDON PORTAGE LA PRAIRIE  
REGINA WEYBURN MOOSE JAW SASKATOON  
CALGARY EDMONTON GLEICHEN CAMROSE  
ETC.



## JOHN DEERE

### The Spreader That Works Right

Will work longer, easier and cost you less

A few of the reasons why:

- 1st. No clutches to give trouble.
- 2nd. No chains to break or get out of line.
- 3rd. Simple, only half the parts used on other spreaders.
- 4th. Convenient, low down.
- 5th. High wheels, light draft.

The only spreader with the Beater on the Axle—Compare with others and see the difference.

GET OUR FREE BOOK, TELLS YOU ALL ABOUT IT ?

## John Deere Plow Company Ltd.

Winnipeg Regina Saskatoon Calgary

M  
poir  
guis  
wate  
eral  
of f  
divic  
fire,  
aver  
sons  
impc  
fight  
It  
the f  
ered  
  
siding  
from  
shuld  
one.  
comia  
metal  
this re  
vance  
U.S. w  
more c  
loss is  
than C  
The  
rapidly  
decreas  
Canada  
in the  
there ar  
damage  
forest fi  
damage  
causes i  
use of r  
ings, an  
by build  
metal sl  
artistic  
durable.  
The l  
fire may  
extent b  
regard t  
even the  
liable to  
tive effe  
one, prov  
not prote  
In con  
farmer w  
lightning  
while lig  
metal rc  
gives bet  
ning bes  
against fi  
gine, etc.  
wooden r  
on.  
Lightni  
property  
anyone ha  
country,  
with its a  
of lightni  
regret a  
diture for  
from the e

point where it can be extinguished. As a rule the supply of water is very limited and is generally quite distant from the point of fire, and in addition the individuals capable of fighting the fire, are limited, comprising on an average not more than two persons. This makes it all the more important that the farmer should fight his fires before they occur.

It is unnecessary to dilate on the fact that a farm building covered with metal roofing and metal



siding is protected against fire from outside influences; this fact should be self evident to everyone. The Canadian farmer is becoming more in the habit of using metal coverings every year and in this respect is considerably in advance of his fellow farmers in the U.S. where wooden buildings are more common and where the fire loss is consequently even larger than Canada.

The danger from forest fires is rapidly diminishing as the forests decrease, but in many sections of Canada and during long dry spells in the summer and fall months there are still vast possibilities of damage from flying embers due to forest fires. All liability to loss or damage from this and many other causes is entirely nullified by the use of metal coverings on buildings, and in the case of residences by building brick walls and using metal shingles, which makes an artistic and pleasing combination, durable, economical and fireproof.

The loss to farm buildings by fire may be controlled to a large extent by exercising care, but in regard to the loss from lightning even the most careful family is as liable to suffer from the destructive effects as the most careless one, providing their buildings are not protected against lightning.

In considering this subject the farmer will usually have in mind lightning rods as a protection, and while lightning rods have a value, metal roofing properly applied gives better protection from lightning besides added protection against fire, sparks from the engine, etc., which might burn a wooden roof with a lightning rod on.

Lightning not only destroys property but destroys life; and anyone having experienced, in the country, a heavy thunder storm with its accompanying discharges of lightning would certainly not regret a slight additional expenditure for the sake of immunity from the effects of lightning. The

# \$ Earn Money \$ BY SAVING IT

## Babbitt Metal

the very best to reline your worn bearings. Two days' pay for hired man saved every time you buy 25 lbs. of our

**HARRIS HEAVY PRESSURE BABBITT**

for all kinds farm machinery.

**Regular 50c lb.  
Special 30c lb.**

Cash with order, C.O.B. Winnipeg.

**Only 4 tons left and going fast. Cannot be long.**

A ways give when ordering name of pump, depth of well, distance to draw water.

Adjust to fit any pump; warranted two years. Order now and have water in abundance always with ease.

**You're losing if not using the Patent Pump Governor**

See It Lift

Your Money Back if not exactly as represented.

	Man.	Sask.	Alta.
Regular - - -	\$2.50	\$2.75	\$3.00
<b>Special - - -</b>	<b>\$1.95</b>	<b>\$2.10</b>	<b>\$2.25</b>

A few hundred to clear at this Extra Special Price now; but never again.

Send cash with order. We deliver at these prices free to nearest post office.

## "Hercules" Foot Scraper

MADE IN WINNIPEG

Clean Floors in 1,000,000 Homes and Business Houses

Do you know that this scraper will save more money in one week than what it costs you? It removes the mud as efficiently as the snow, and has a Heel Plate which is very effective.

**Price \$1.00**

Delivered to the nearest R.R. Station or Post Office in Manitoba, Sask. or Alberta.

## The Western Steel and Iron Co. Limited

AUTHORIZED CAPITAL \$300,000. Established 1906

**WINNIPEG Manufacturers CANADA**

feeling of terror usually engendered in the minds of the family, conscious of their helpless and unprotected condition, is more conducive to a high state of nervousness with its accompanying physical break-down than almost any other cause. As the spring comes on, this subject recurs more frequently and in the hot summer days, with their heavy thunderstorms, lightning becomes a very constant source of dread and trouble.



Very careful observation has finally established a fairly good understanding as to the operations of electricity and the methods of minimizing the effects of same; lightning is a discharge of a large amount of electricity in a very short space of time, and whatever medium conducts it from the clouds to the earth suffers in the transmission, unless the medium is a first class conductor of electricity, and of sufficient size to take care of the full volume of the discharge. Trees, poles and buildings, on account of their height generally act as conductors. In the case of buildings, an electrical discharge is generally accompanied by fire, and a severe fire in the midst of a thunderstorm brings to

Continued on page 59

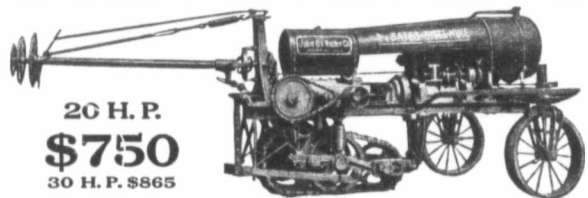

## WHY The Bates Steel Mule Instead of a "Tractor"

- One Man Does the Plowing** He sits right on the three plows, away from the heat of the engine, where he can watch both plows and "Mule" without turning his head.
- One Man Does the Discing** He pulls a double disc with a two section harrow behind at a good speed without packing the ground.
- One Man Does the Drilling** He sits on his grain drill where he can watch both drill and "Mule". He pulls two sections of harrows behind the drill.
- One Man Cultivates Corn, Cotton, Potatoes, etc.** He sits on a two row cultivator and does an even, thorough, quick job. The "Mule" guides easily, turns short and does not pack the soil.
- One Man Does the Harvesting** He sits on the Binder where he can watch both Binder and "Mule" move through the heaviest grain at a fast, steady gait. "The Crawler" makes a path for the Binder Wheel when going through mud.
- Belt Work** He can pull large Ensilage Cutters, Medium Sized Threshers, etc.

**This Gets The Footing**

Spring Mounted "Crawler"

**Can You Afford to be without one?**

One Man Harvests 40 Acres a Day

One Man Cultivates 31 Acres a Day

For Full Details and Guarantee write—  
**FRED. M. WARNER**  
NORTHWESTERN DISTRIBUTOR  
**407 N.P. AVE. FARGO, N.D., U.S.A.**  
DEALERS—Some good territory open. Get our selling plan.

The Art of Blacksmithing  
As applied to the trade

ARTICLE No. 3  
Forges and Tools

Brick Forge

A forge is an open fireplace or hearth, with forced draft, arranged for heating iron, steel and other materials. A serviceable form of brick forge is shown below.

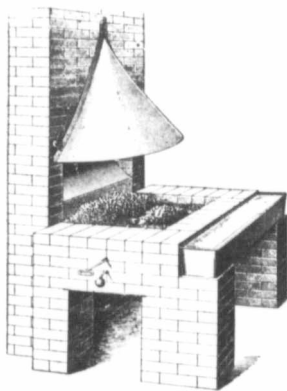

Fig. 1

The hearth is usually rectangular in shape and 26 or 28 inches in height. For ordinary work the front may be from 2½ to 3 feet long and the side from 3 to 4 feet long. An iron water trough, 6 to 8 inches wide, is often fastened along the side. The brickwork is usually built with a space in the top for the fire and fuel. The depth of this space varies greatly, according to the work and the ideas of the workman, but it is usually from 4 to 8 inches. The bottom consists either of brickwork or an iron plate supported on bars.

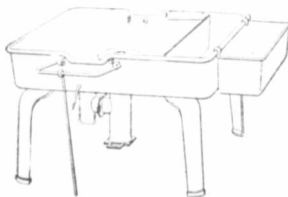

Fig. 2

The forge is usually provided with a hood to catch the smoke and lead it into the stack or chimney. The cut shows a sheet iron conical hood attached to the chimney, but the hood may be square and is sometimes built of brick, where there is plenty of

room in the smith shop, and the blast is supplied by hand power, the brick forge is the type most frequently used. The advantages

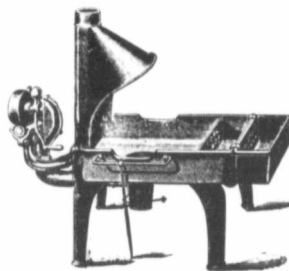

Fig. 2A

claimed for it are that it is little affected by the moisture of the atmosphere, costs less for repairs than the iron forge and the form of the hearth may be quickly and easily changed to suit the requirements of the various classes of work.

Iron Forge

The iron forge is made with a cast iron bowl supported on legs. The tuyere iron is fastened in the bottom of the bowl and the air blast is supplied either from a stationary blower or bellows or from a small blower secured to the forge.

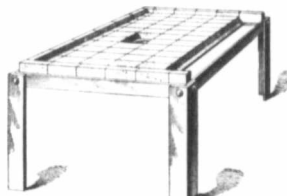

Fig. 3

The blower may be driven by a crank, a tread or a lever working with a ratchet. The following cuts show an iron forge which is suitable for either stationary or portable use.

It has no hood to obstruct the handling of the work. The blast is supplied from a blast pipe or from a small portable blower mounted on a separate stand. This forge shown in cut is equipped with stand or rest for tongs or long piece of work and may be folded out of workman's way, also a water and coal trough, it also shows top of tuyere, the valve for the blast pipe and the cinder valve at bottom of the tuyere iron.

Combination Forge

Sometimes a combination brick and iron forge is made by supporting a frame of 2 inch or 3 inch angle iron about 3½ or 4 feet by 6 feet on angle iron legs as shown in following cut:

The bottom is formed of ½x2 inch iron strips supporting a layer of common red brick. The tuyere iron is attached to two of the ½ inch iron strips and the bottom of the hearth is covered with clay or cinders.

Portable Forges

Portable forges are those that may be moved about easily. They are of various designs and construction in order to meet the requirements of different class of

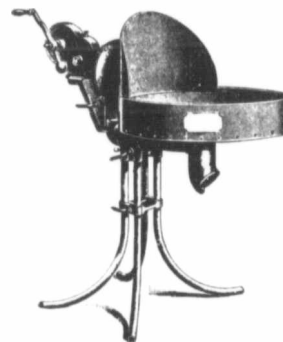

Fig. 4

work might have to be done by blacksmiths, others by machinists, bridge builders, boilermakers, etc.

The one shown in the cut or one similar, is a desirable forge for the farm, it has many advantages over a stationary forge and the two principal ones are that you can always take the forge to where the work is to be done when it is impossible to bring the work to the forge, which is a big consideration on the farm. The usual design of these portable forges are as follows. It has a cast iron bowl usually supported on legs made of gas pipe. The blast is supplied from a small rotary fan secured beneath or at the side of the bowl and operated by hand. The bowl, fan and tuyere all contained within its self.

Forge Tuyere

The bottom of the forge has a suitable opening cut in it which is fitted a tuyere iron, sometimes called an air chamber or a wind

box for the purpose of admitting air under the fire. The bottom of the tuyere iron has an opening about the same size as the opening.

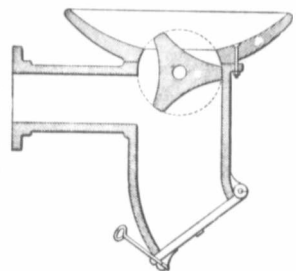

Fig. 5

cut in the bottom of the forge. This opening is closed by a valve of thin iron by means of a handle.

The above cut is shown in section of one form of tuyere iron, commonly used. It has an opening in onside and one in its top. The side opening is connected with a pipe through which air is supplied to the fire. The top opening is usually capped with a nozzle and fitted with a valve. This valve is made so that it will admit air to the fire and permit the cinders to drop into the bottom of the tuyere iron, between heats or when the blast is shut off, the cinders are dropped from the tuyere iron into a cinder pit by opening the valve which is hinged and operated by the rod. The nozzle with the valve at the top of the tuyere iron is called the tuyere.

The valve is controlled by a handle from the side of the forge. For power forges a separate valve controls the amount of opening for the air supply. The top of the tuyere is usually so placed that it comes 3 or 4 inches below the level of the top of the forge and from 12 to 15 inches in front of the chimney of a stationary forge. The bottom of the fire space is occasionally filled with clay hollowed into a cup shape around tuyere. In doing this, care must be taken to work or temper the clay to a proper consistency, for the stiffer it is the less it will shrink and crack. Strong brine is often used to moisten the clay as it keeps the bed from burning out too quickly. The space above the tuyere is also sometimes packed with cinders to the level

Continued on page 18



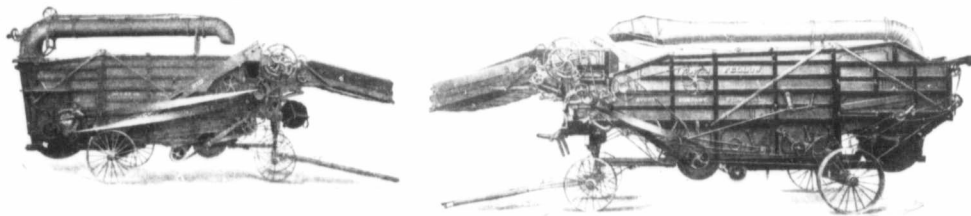

## YOU MUST HAVE A GOOD RIG TO SATISFY YOUR CUSTOMERS THIS YEAR

The high price of grain will make your customers more than usually anxious to save their grain and to thresh it quick without delays this year.

You can meet every demand made with an Avery Separator.

There's no possible question about the ability of an Avery to save the grain with such grain saving records behind it as an average saving of 99.9-10 per cent. in 27 canvas field tests.

There's no possible question about the ability of an Avery to stand up on the job when we use such good materials that we can guarantee Avery cylinder teeth for life against such breakage.

Just think of all these features in an Avery that

help you to do the kind of work that makes more profits for you—rubber feeder web that saves wasting the loose grain, tool steel cylinder teeth that save stops, I X L grain saving device that tears up the bunches and makes the grain drop through, special shoe that does better cleaning, belt tighteners that prevent stops for loose belts, cone pulley belt guide that saves wearing out drive belts—these and many other features are regular equipment on Avery Separators.

And you can get an Avery in any size you want, 19x30 or 22x36 inch "Yellow Kid," or 28x46, 32x54, 36x60, 42x64 or 42x70 inch "Yellow Fellow"—a size to fit every size run.

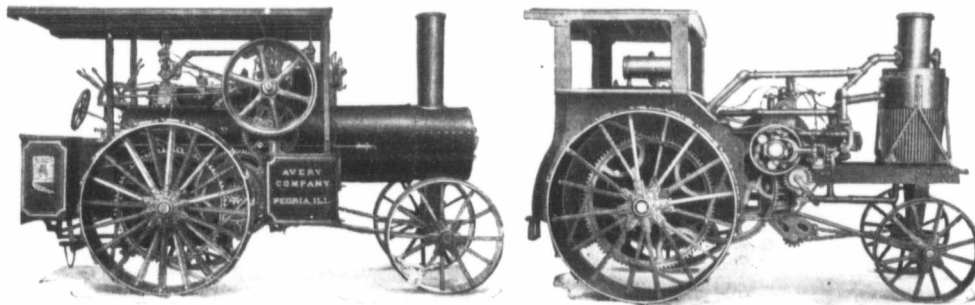

## STEAM, GAS OR OIL POWER

If you want steam power we have either a 16, 20 or 25 H.P. Steam Engine for you. If you want gas or oil power you can select any one of 5 sizes: 8-16, 12-25, 18-36, 25-50 or 40-80 H.P.

Avery steam engines have special high pressure reinforced boilers with improved heaters, rocker

grates, automatic couplers and automatic fire doors. Avery gas and oil tractors have special opposed motors that are built to stand up under heavy belt or traction work and deliver steady uniform power for belt work.

We have been told many times this year that the 1916 Avery catalog is the most interesting and complete catalog ever issued. Write for a free copy and learn all about Threshing, Tractor Farming and Road Making with Avery Machinery.

**EVERY COMPANY** Canadian Avery Co. Ltd.  
675 IOWA ST., PEORIA, ILL. Western Canadian Distributors WINNIPEG REGINA

# EVERY

# Make Hay While the Sun Shines

If you can, but if the shines are few and far between, you will have need of the most improved Hay-Making Implements, and here they are.

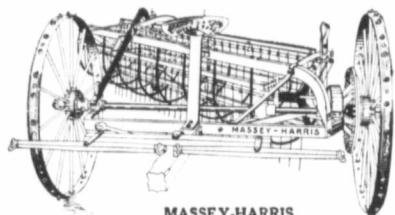

MASSEY-HARRIS SIDE-RAKE AND TEDDER.

Quickly changed from one to the other, and satisfies the most exacting in either capacity. Made almost entirely of Steel. Gearing is strong and simple—fast speed for tedding, and slow reverse motion for raking. Angle of Teeth adjusted by a convenient Lever.

**MASSEY-HARRIS CO., Limited.**  
 Head Offices—Toronto, Canada.  
 — Branches at —  
 Montreal, Moncton, Winnipeg, Regina, Saskatoon, Swift Current, Calgary, Yorkton, Edmonton.  
 — Agencies Everywhere —

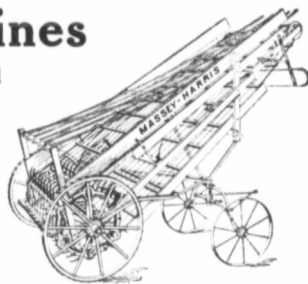

MASSEY-HARRIS HAY LOADER

Simple in construction—will not get out of order. Yields automatically to any obstruction or unusual volume of hay. Places the hay well forward on the load. Its motion is steady and constant. Furnished with or without Forecarriage.

**They Save Many a Crop which would otherwise be Damaged by Rain or Exposure**

of the tuyere. Suitable space is provided in the forge bottom for the free movement of the handles, sometimes by encasing them in pieces of wrought iron pipe.

The above cut shows another common style of tuyere iron which is of cheaper and simpler construction than that shown first. The dish shaped nozzle has a circular hole in the bottom below which is the valve. By turning different the rod the valve is brought into different positions, these increasing or diminishing the opening.

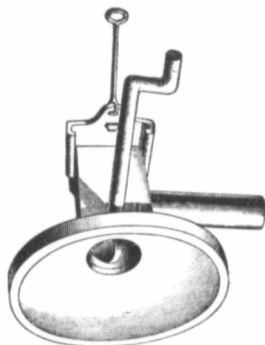

Fig. 6

The blast enters through the pipe at the side. The tube is closed at the lower end by the shutter. When cinders have collected the shutter is opened by means of the rod and the cinders dropped out.

### Production of Blast

The bellows. The air blast is produced either by means of a rotary fan or blower or by a bellows.

The bellows as shown above consists of two parts. These are separated by a partition and the air from the lower half is forced

through the valve in the centre board into the upper chamber where it is stored for use. The bellows is hung from the centre

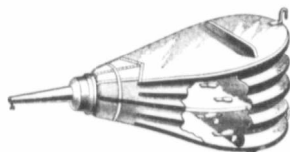

Fig. 7

board by pins and as the lower board is drawn up the air in the lower part is forced through the valves into the upper chamber inflating it and raising the top board. As the bottom board descends the valve in the centre board closes and the valve in the bottom board opens and allows the air to flow in and fill the space below the centre board. By placing a weight on the top board the air pressure in the upper part is increased. The top board should be held up when the bellows is idle, for any great length of time to keep the leather stretched to prevent it from cracking. This may be done by fastening the hook shown in a chain suspended from the ceiling. With this care the bellows will last much longer, for if the upper part is always folded together when not in use, the leather will soon crack and the upper will be spoiled while the lower half is still in good condition. The operating chain or rod is attached to the hook shown on lower part of bellows and the air from the upper part discharges through the tube or nozzle. The leather of the bellows should be oiled two or three times a year with Neats-foot oil or harness oil to preserve it. It should always be oiled before cold weather sets in

so as to make it pliable during the winter.

Rotary blower or fan. The rotary blower or centrifugal fan has

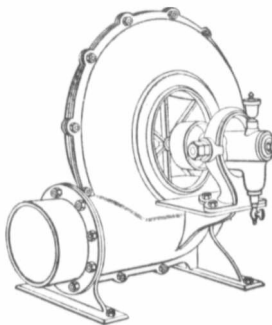

Fig. 8

a number of blades set nearly radially on the shaft and placed within a cylindrical iron casing with inlet holes concentric with the shaft on each side and an outlet opening into the delivery pipe at the periphery of the casing.

The shaft is driven by a belt passing over the periphery in the above cut, but in hand rotary blower this is accomplished by a series of straight and worm gears. The centrifugal force caused by the rapid rotation of the blades, throws the air outwards, that is, away from the centre. The air close to the shaft rushes through the opening at the centre to fill this space and so a constant blast is maintained.

For small forges hand driven rotary fans are very frequently used. There are a number of styles on the market driven by cranks either through trains of gears or through belts. These portable hand blowers however, are used more in small smith shops than in blacksmith shops connected with manufacturing plants.

One of their principal advantages is that they take up less room than the bellows and are in many cases capable of producing a much greater blast pressure.

## Liquidator's Sale

### COMPARE THESE PRICES

They are less than manufacturers' cost. The goods are perfect in every way and there is no better machinery made today for supplying power on the farm.

#### OHIO ENGINES

15 H.P. Standard (new)	\$328.75	12 H.P. Standard stationary (new)	\$414.15
12 H.P. Standard (new)	206.50	10 H.P. Farm Engine, hopper cooled (new)	256.35
11 H.P. Special Hopper cooled (new)	189.00	8 H.P. Farm Engine, hopper cooled (new)	197.90
12 H.P. Standard (rebuilt)	200.00	6 H.P. Farm Engine, hopper cooled (new)	148.70
8 H.P. Standard (rebuilt)	175.00	2½ H.P. Farm Engine, hopper cooled (new)	55.00

#### TRACTORS, STEAM

35 H.P. double cylinder (rebuilt)	\$2,500
25 H.P. Northwest (rebuilt)	1,000

CASH PRICES except in case of Tractors and Portables for which, reasonable terms will be considered at increased prices.

**R. S. Ewing, Assignee, 200 Union Trust Bldg WINNIPEG**

M  
 I  
 so c  
 eit  
 ash  
 fan  
 fro  
 ing  
 mot  
 mot  
 I  
 forg  
 fire  
 the  
 the  
 in t  
 hood  
 it an  
 chim  
 the r  
 provi  
 whiel  
 whiel  
 quite  
 The  
 cated  
 sible,  
 avoid  
 becau  
 loss in  
 air thr  
 ing al  
 any pi  
 curves,  
 ber of  
 from o  
 be tak  
 branch  
 rectly,  
 be run  
 more t  
 near th  
 loss of  
 ensur  
 tuyere.  
 The  
 blowers  
 proper s  
 pipes.  
 D  
 Some  
 into the  
 not run  
 mixture  
 explode  
 the fan  
 bellows  
 ispartien  
 pipe is o

**Sw**  
**The Gi**  
 For feed  
 closer, 8  
 any soft,  
 and in ad  
 conditions  
 Sow from  
 broadcast  
 Particular  
 tested, 25  
 12 lbs., \$  
 50 1  
 100  
 By Exp.  
**Wm. G**  
 of Can  
 Dept. 217

A good hand blower should be so constructed that it can run in either direction without drawing ashes back into it. Power driven fans may be operated by a belt from a pulley on the line of shafting by a belting from an electric motor or by direct connected motor.

**Hoods and Chimneys**

In the case of a single stationary forge like that shown as a brick forge, the gas and smoke from the fire are usually drawn up through the hood by the natural draft of the chimney where the forge stands in the centre of the room. The hood is sometimes suspended over it and connected with a sheet iron chimney going straight up through the roof. If these chimneys are provided with some form of top which will insure a draft no matter which way the wind blows they are quite efficient.

**Blast Pipes**

The fan or blower should be located as close to the forge as possible, and care should be taken to avoid unnecessary bend in the pipe because there will be considerable loss in the pressure when forcing air through a long pipe or one having abrupt bends. The bends in any pipe should be made in easy curves, in case where a large number of forges are supplied with air from one fan or blower care must be taken to proportion the various branches of the pipe system correctly. The fan or blower must be run at a speed that will give more than four ounces pressure near the fan in order to allow for loss of pressure in the pipe and ensure the proper pressure at the tuyere.

The manufacturers of fans and blowers furnish tables giving the proper size and proportion of blast pipes.

**Danger of Explosion**

Some times coal gas works back into the blast pipe when the fan is not running as at noon, forming a mixture of gas and air that may explode and burst the pipe when the fan is started or injure the bellows as the case may be. This is particularly the case if the blast pipe is overhead. The dangers of

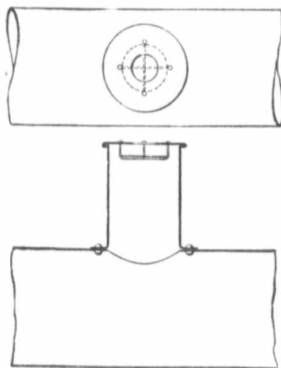

Fig. 9

explosion may be prevented by having one or more valves in the top of the pipe as shown in the above cut, to allow the gas to escape.

The valve is made of thin sheet iron and is held up by the blast when the fan is running, but drops on cross wires and permits the gas to escape when the fan is not running. A top view of this valve is also shown in the above cut and is three inches or more in diameter.

**A BRAVE YOUNG RANKER**



VICTOR BRAY

It is very refreshing to turn from the smartly uniformed young "unattached" of the sidewalk to the rank and file, the real fighting boys of the Dominion as they march along with squared shoulders and stiffened lip to their day's training for the battle front.

Young Victor Bray, erstwhile student of St. John's College, Winnipeg, and youngest son of F. E. Bray (Lake of the Woods Milling Co.), 628 Broadway, did not engage the "influence" of any of his own or the family friends to procure him a commission. No, he "took the shilling" like a true sport, and as a representative democrat, in keeping with the whole traditions of his forbears he went into the ranks of the 184th Battalion.



**HARD WALL PLASTER  
SEWER PIPE CEMENT  
PLASTER PARIS LIME  
FIRE BLOCK MORTAR  
FIRE CLAY COLORS  
AND ALL OTHER BUILDING SUPPLIES**

**Thos. Jackson & Sons, Colony St., WINNIPEG**

**Provincial Exhibition**

**BRANDON, MANITOBA  
July 17th to 22nd, 1916**

**Manufacturers are Invited to Exhibit**

Those who have patronized this Big Fair, have demonstrated that it pays. It is here the Manufacturer meets the farmers and buyers.

**The Provincial Exhibition of Manitoba**

We inaugurate the first Light Tract Plowing Demonstration in Canada. Not a Competition, simply a practical demonstration on land close to Fair Grounds.

Outside Display Space Free—Nominal charge for inside space—Ample inside space for automobiles.

Write for Prize Lists. Entries close July 8th. Make application for display space early.

**A. C. McPHAIL,**  
President.

**W. I. SMALE,**  
Secretary and Manager.

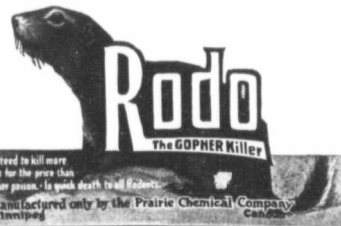

**Resolution Passed at "RODO" Convention**

Rodo adopted by unanimous vote as the most reliable gopher poison. It was further resolved that every farmer must use Rodo during Rodo Roundup Days — June 1 to 10.

Rodo can be purchased from your druggist, or if unobtainable, the manufacturer will send it post paid on receipt of price—25c, 50c or \$1.00 sizes, manufactured by

**PRAIRIE CHEMICAL CO.**

**ANTON MICKELSON, Manager**

**304 Keewayden Bldg., Winnipeg, Man.**

For better, for worse, he will now do exactly what he is ordered to do and bravely set his teeth to any task assigned him. He is proud to call the humblest man in that grand army of Canadian boys his comrade in arms, and like a true soldier will wear every stripe or decoration that it may be his good fortune to receive.

With some 30 fellow students of St. John's, Victor (now in his eighteenth year) donned the King's uniform to fight in the great war of liberation. We are happy to reproduce his photograph

and to say that we are proud of him inasmuch as he is a native-born citizen of Winnipeg, and that he is the young brother of our old college chum, Frank C. Bray, with whom we are now associated in the rising fortunes of the Canadian Thresherman and Farmer.

**A Feminine Device**

"I thought the Christmas expense was over, but it isn't."

"How now?"

"My wife has exchanged a lace handkerchief and six hundred dollars additional for a fur coat."

**Sweet Clover  
The Great Weed Destroyer**

For feeding purposes, better than red clover. Similar to alfalfa. Thrives in any soil. Grows on our famous Seed and Percheron Farm in Saskatchewan and is adapted to Western Canadian conditions.

Sow from now until July 1st; drill or broadcast fourteen pounds per acre. Particulars free. Prices on high tested, guaranteed, pure seed:

12 lbs., \$3.75; 35 lbs., \$7.75;  
50 lbs., \$14.00  
100 lbs., \$28.00  
By Express or Freight

**Wm. Galloway Co.**  
of Canada Limited  
Dept. 217 WINNIPEG



# An Industry That Relies Entirely Upon Grain Raising

It was a source of pleasure to hear that our friends the Hart Grain Weigher Company of Peoria, Illinois, were making arrangements to market more of their lines in Western Canada this year.

All of the Canadian threshermen are familiar with the Hart

thresher trade with the Langdon Feeder. This feeder was, as has been the case with so many feeders, first brought to light in the southwest. After having been tried in more or less of a local way in that territory for a couple of seasons, the feeder was manufactured more extensively and sold in gradually increasing territory until its sale had spread from the Atlantic to the Pacific and from the northern to the southern boundary of the United States.

The season of 1915 was one of probably the most trying conditions in the memory of the users of threshing machines. In the extensive territory in which the Hart Grain Weigher Company were selling their attachments, practically every condition under which threshing might needs be done was encountered in the one season of 1915. From threshing in the longest, driest, most brittle grain to the handling of rank grown tangled, roted straw the feeder closed the season with a perfect score.

village of importance in the three prairie provinces. The Hart Weigher Company are so well acquainted with the conditions in Western Canada that they can be relied upon to take care of the trade by having stocks of repairs where they can be obtained quickly.

A little about this company and the goods which they manufacture may be of interest to our readers.

This company was founded in 1889 by Stacy B. Hart. It has manufactured Baggers and Automatic Registers, or what are known as Grain Weighers in the States, since that date. This company is the largest manufacturer of this class of machinery in the world. Practically every threshing machine in the United States and Canada is equipped with a machine of their manufacture.

Mr. Hart, the founder of this company, died January 30th, 1913. He was a character familiar to all of the older branch managers of the thresher companies.

Under the guidance of these men, with their years of experience, and the aid of splendid factory equipment and scores of specialists in the line, it is of little wonder that a feeder has been produced that is in keeping with the reputation of the company.

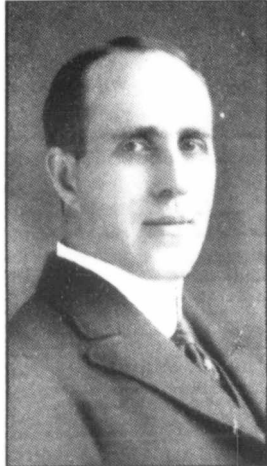

W. B. WYLDE, President and Treasurer, Hart Grain Weigher Co.

Grain Weigher Company. For years they have supplied them all of their Baggers and Automatic Registers. The name "Perfection Bagger" is a household word with the Canadian threshermen. But not so many were familiar with the fact that this old established company were large manufacturers of band cutters and self feeders.

For a number of years the Hart Grain Weigher Company has been manufacturing and supplying the



Portion of the Plant of the Hart Grain Weigher Co., Peoria, Ill.—A Number of Additions Since the Photo Reproduced Was Taken

A few of the three feeders have been sold each year in Western Canada. The officers of the Hart Grain Weigher Company believed that there should be a larger market for this feeder in Canada. For some time their vice-president and general superintendent, A. J. Hartley, and sales manager, H. A. Coffman, have been travelling through Canada studying conditions. So well impressed were they with the future market for their feeder in this territory that they have made arrangements with the Cushman Motor Works of Canada, Limited, of Winnipeg, to represent them in Western Canada.

They are making arrangements to carry stocks of feeders and repairs for these in the principal machinery centers in the West. There will be an agency representing the Langdon Feeder in every town and

The present officers of the company are as well known to the fraternity of to-day.

Mr. W. B. Wylde, the president and treasurer of the company, was the original manufacturer of the Washington Weigher made at Washington, Iowa. He joined the Hart Grain Weigher Company in 1899.

Mr. A. J. Hartley, vice-president and general superintendent, was the head of the C. J. Hartley Company of Decatur, Illinois, the manufacturer of the Hartley Automatic Register and Bagger. Mr. Hartley joined the Hart Grain Weigher Company's organization in 1913.

Mr. H. A. Coffman, sales manager of this company, was in the retail and wholesale implement business in central Illinois until his connection with the Hart Grain Weigher Company in 1910.



H. A. COFFMAN, Sales Manager, Hart Grain Weigher Co.

The Langdon feeder embodies a principle in advance of the common practice. Not only is the feed of the grain to the separator regulated according to the speed of the engine and the volume of the grain, but also according to the condition of the grain. This feeder really governs according to the resistance which the grain offers to the threshing cylinder. While the feeder might be covered so as to only start and stop at a given speed and to always allow an even thickness of grain to go into the cylinder, still conditions are sometimes such that mixed in the same load are bundles of grain of greatly varying conditions, the bundle of grain of equal volume with another may, on account of its tough, tangled or matted condition, offer very much more resistance to the cylinder than one that is dry and straight.

The result is that when such a bundle as this reaches the cylinder it is very liable to cause what is known as the slugging of the cylinder or the checking of the power. The manufacturers of the Langdon Feeder claim that they have overcome this difficulty, and that they can always positively guarantee a feed to a separator all that the separator can handle and without the checking of the speed of the cylinder and the balance of the outfit.



A. J. HARTLEY, Vice-President and General Supt., Hart Grain Weigher Co.

No Feed. band revol. rear ance, lockir bundl With sible spikes enable for s better is oth the Li LAN T necess of a s yet lig or swi end m

TI but thi or any additio ASK FI

CUS

The H. pany, in Feeder al full line and Bagge are so fan grain ha manufactr riers whic A separat devices ca a great d and teams sible. A going to be lens in C son, no do be greatly i their line.

# PREPAREDNESS — THE PROGRAM

*It is up to you Mr. Thresherman to prepare to take care of your crops with less men and to take care of them at the proper time. Every last possible kernel of grain is needed and must be saved*

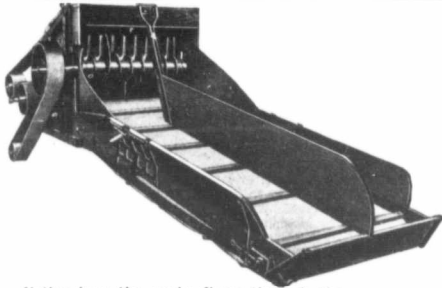

Notice how the grain flows through the Feeder to the cylinder. After passing the band knives it must pass between the rapidly revolving rear knives and the slowly revolving retarder. When for any reason the rear knives meet more than ordinary resistance, the retarder is forced downward, locking the conveyor and retarder till the bundle is thoroughly separated and divided. With this Automatic Governing it is impossible to slug the cylinder, break or bend spikes or concaves. Any device that will enable you to keep your cylinder and separator speed uniform will enable you to do a better job of separating and cleaning than is otherwise possible. This is exactly what the Langdon does.

## LANGDON WING FEEDER

This machine will prove to be a big labor and time saver for you in any kind of threshing. It is a necessity in stack threshing and a big money saver in shock threshing. The Hart-Langdon consists of a self-feeder, the main body of which is the same as the famous Langdon Ideal, but with a strong yet light weight set of wings, built into and made a part of it. The wings may be raised and lowered or swung about as desired. They are provided with a hinged joint at the center so that the outer end may be folded over for moving or entering a barn.

### HART-BROWN WING CARRIER

The Hart-Brown Wing Carrier does the same work as the Hart-Langdon Wing Feeder, but this machine consists of only a set of wings which may be used in connection with any feeder or any separator, old or new. The Hart-Brown is for those who have a good self-feeder and wish the additional advantage of the wings.

ASK FOR CATALOG

HART GRAIN WEIGHER CO., Peoria, Illinois, U.S.A., Manufacturers  
 CUSHMAN MOTOR WORKS OF CANADA, LTD., Winnipeg, Man., Distributors

Why not let the Langdon Automatic Governors work for you?

### AN AUTOMATIC SPEED GOVERNOR AN AUTOMATIC VOLUME GOVERNOR AN AUTOMATIC CONDITION GOVERNOR

all working in unison to feed your separator to full capacity all the time, yet governing against slugging or overloading the cylinder. The Langdon Automatic Volume and Condition Governors operate independent of the speed governor. This means they govern without affecting the speed of your separator or engine. It is the one Feeder that governs against and prevents overcharges of wet, tangled or stack-burnt grain reaching the cylinder, without cutting down the feeder's capacity for handling dry, straight grain.

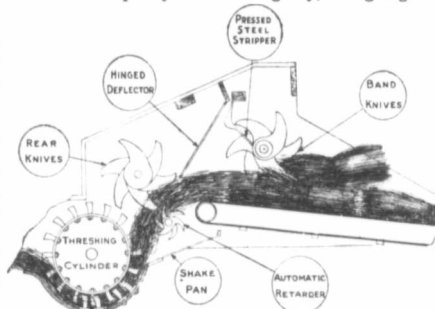

The Langdon is a clean feeding device. The hinged deflectors absolutely close the opening between the hand knives and the rear knives, so there is no possibility of grain throwing out through the feeder. The vibrating Shake Pan fills up the opening between end of conveyor and the cylinder, catches all litter and delivers it to the cylinder—no time wasted in the clean-up. Figure up what this saving alone will mean to you.

You can use the Langdon on your separator, no matter what kind it is. You can handle any kind of grain, bound, loose, wet, dry, tough or tangled. The Langdon means more threshing, better threshing, more grain saved, less wear and tear on the separator and engine.

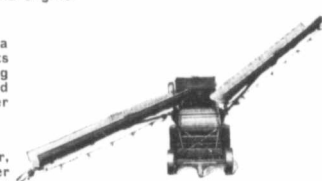

HERE IS YOUR OPPORTUNITY—GRASP IT

The Hart Grain Weigher Company, in addition to the Langdon Feeder above mentioned and the full line of Automatic Registers and Baggers—with which the trade are so familiar, make many other grain handling devices. They manufacture a line of Wing Carriers which are great labor savers. A separator equipped with these devices can do the threshing with a great deal less number of men and teams than is otherwise possible. As labor conditions are going to be one of the trying problems in Canada this harvest season, no doubt the threshermen will be greatly interested in this part of their line.

They are also manufacturers of a full line of grain handling elevators, both portable and stationary. These elevators are a great help in the handling of the grain after it has been threshed, as with them the grain can be loaded into granaries, bins or cars without the aid of scooping. The Hart Grain Weigher Company is ideally located for the manufacture of machinery. Their large plant, only a part of which is shown in the cut on other page, is located on the Illinois River—part of the great waterway project of the lake to the Gulf Route—and on the tracks of railroads whose lines lead to all the points of the

American continent. Their facilities for loading and unloading material are unequalled. A visitor to their plant is surprised at the tremendous quantities of threshing attachments which are being shipped from this plant each day, and it is hard for them to realize that so many of these could be used each year. Their main factory building, consisting of six floors, all filled with modern and special machinery, represents an enormous investment. Every die and jig and labor saving device that it is possible to obtain has been utilized to manufacture their products in the

most modern and economical way. This whole plant is equipped with an automatic sprinkler system which reduces the dangers of fire to the absolute minimum. This company has profited by their experience of some years ago when their modern plant was completely levelled by a disastrous fire. Recently very large additions have been made to the already large plant. A large warehouse is just now being completed. The foundry also has been greatly enlarged, but little of the foundry and some of the additions mentioned show in the cut on opposite page.

5 H.P.  
Crushing Outfit  
Complete  
\$163.00

# Complete Crushing Outfits

7 H.P.  
Crushing Outfit  
Complete  
\$223.00

## 5 H.P. ENGINE

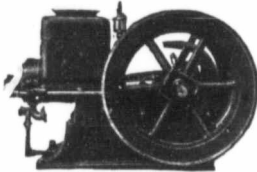

**\$130.00**

## STOVER GRINDERS

6 in. only  
**\$26.00**



**LOW DOWN WELL BUILT**  
Crushes every kind of seed.  
Fine or coarse plates.

## GRINDER PLATES

7 inch, per pair.....\$1.60  
8 inch, per pair.....\$1.65  
10 inch, per pair.....\$2.00  
12 inch, per pair.....\$2.25

## The Engine You Really Need

**7 H.P. Price \$185.00** Equipped with self-starting Webster Magneto  
This Engine will use less fuel than any engine of the same rating, and is guaranteed to develop more horse power than any engine of the same or nearly the same rating.  
**BETTER ENGINES ARE NOT MADE**

## GUARANTEED PLOW SHARES

Prices subject to change without notice. If money is sent in good faith goods will be shipped.  
12 in. Shares, each, \$1.80 14 in. Shares, each, \$2.00 16 in. Shares, each, \$2.25  
13 in. Shares, each, \$2.00 15 in. Shares, each, \$2.25 18 in. Shares, each, \$2.60  
Give number and letters stamped on a share—and name of plow—we do the rest.



**Channel Steel Harrows**  
A very popular high grade harrow at a very low price.



60 tooth, 3 section, 9 ft. ....\$13.50  
100 tooth, 5 section, 15 ft. ....\$17.50  
120 tooth, 6 section, 18 ft. ....\$21.50

**\$1.80**

**Saw Blades**  
From \$5.50 up

**Harrow Teeth**  
Guaranteed Quality, 5c

**WE HANDLE**—Cordwood Saw Frames, \$15.00; Power Straw Cutters, \$35.00; Wheel Barrows, Pulpers, Pump Jacks, \$5.50 and \$7.50; Dry Cells, 35c each.

# THE CANADIAN STOVER GASOLINE ENGINE CO. Ltd.

BRANDON, Man.

## Celebrated Eclipse Plow

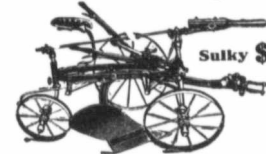

**Sulky \$45.00**

1915 Prize Winner at Plowing Matches.  
12 inch Gang, \$65.00 14 inch Gang, \$67.00

## STOVER POWER WASHING MACHINE \$22.00

Our complete Power Washing Outfit, consisting of 1 1/2 H.P. Engine, Washing Machine and Belt. Complete at \$60.50.

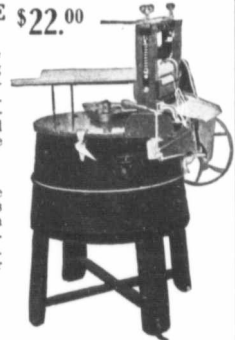

All gears are covered. Has safety release on wringer. Reversible Wringer. Pure Rubber Rolls.

**CLEAN YOUR GRAIN WITH CANADIAN STOVER \$38. 50**  
1 1/2 H.P. ENGINE

Practical Talks to Threshermen  
Continued from page 12  
behind the tractor is to reduce the weight on the front wheels one-third or 333 1-3 pounds.

This leaves an effective weight of 666 2-3 pounds on the front wheels to hold them to the ground and resist the 200 pounds of side draft. On level ground this is evidently sufficient and the usual assumption of setting the center of gravity at one-quarter of the wheel base ahead of the rear axle seems justified provided the point of hitch for the load is not taken higher than twenty inches above the pivot point a. If it is taken higher it is evident that the lift would be correspondingly increased. For example, if the hitch were exactly behind the rear axle and thirty inches above the point a, the lift would amount to 500 pounds or one-half the weight on the front wheels.

Let us now investigate the problem and see what would happen if we attempted to pull the same load up a fifteen per cent grade. This is about as steep a grade as a tractor can operate on. The pulling power of the tractor would be considerably reduced on such a grade but for the purpose of this discussion we shall assume that it is just the same as on level ground. In order to see what will

happen it will be necessary to tilt the machine and find new lengths of lever arms, Figure 2. It will be observed first that the center of gravity has approached the rear axle and instead of being at a distance of twenty-one inches it is now 11 1/2 inches. Likewise, instead of the load on the front wheels acting through a lever arm of eighty-four inches this has been reduced to 81.14 inches. The effect of these changes will now be considered.

A reference to the figure shows that the center of gravity has shifted toward the rear until it is only 11 1/2 inches ahead of the rear axle; likewise the force of gravity acting through the front axle has reduced the length of its lever arm from 84 inches to 81.14 inches. Since the center of gravity has moved toward the rear it follows that a greater proportion of the total weight of the machine rests on the point a.

The weights will be in the same proportion as the distances 11 1/2 and 84.14. The weight resting on the front axle will therefore be:

$$11.5 \times 4,000 = 564 \text{ pounds.}$$

Using this weight and the corrected distances and taking moments about a we have:  $564 \times 81.14 = 45,762.96$  inch pounds the moment acting downward to the right of a.

$1,400 \times 20 = 28,000$  inch pounds, the moment on the left. The difference amounts to  $17,762.96$  inch pounds, which divided by 81.14 gives a quotient of 219 pounds as the effective weight for holding down the front end of the machine. This would probably be sufficient but it is very little more than the amount of the maximum side draft and any less weight would make it necessary to shift the center of gravity farther forward.

### Slipping Belt Often Means Load is Too Heavy

The slipping belt is a great annoyance, but it is not always remedied by tightening the belt. Ordinarily, if the proper-sized

belts and pulleys are used and properly put in, there should be little or no slipping at all. Often the slipping of a belt is due to the overload carried by it. There is economy in using wider belts than is the usual practice. Many a three-inch belt is made to do the work of a four-inch belt, much to the annoyance of the operator and the ruin of the belt.

However, when an immediate remedy is needed, a small quantity of powdered whiting, sprinkled on the inside of the belt, is very good and is the least harmful of any similar application.

The use of beeswax, rubbed on the inside of the belt or on the pulley, is a very good remedy in cases of emergency.

Many people use powdered resin on a slipping belt but this is bad practice because it soon dries the leather and causes it to crack.—W. E. Edmondson, Colorado Agricultural College.

If you are forced to put a bell on one of the cows, do not make the highly-strung nervous cow carry it and submit to its constant clanging. Such a cow usually pays the best of any in the herd, and a bell will not increase her profits.

**YOUR NEIGHBOR** would like to see this copy of the Canadian Thresherman and Farmer. He wants to get in on our big Wheat Estimating Contest. Increase your own estimates and your chances of winning the Chevrolet Car by getting him to subscribe.

Ma  
Som  
oli  
In  
tions  
ey in  
prod  
made  
Ga  
the a  
water  
ried  
ture  
with  
tain  
a ful  
gasol  
the su  
up an  
line p  
in a  
waits  
duces  
violent  
In t  
as fast  
line a  
of the  
case th  
and mi  
to form  
upon ig  
One  
tirely  
32 cubi  
ed mat  
gasolin  
air, no  
sult. A  
air will  
of gasol  
the gra  
parts by  
line, an  
place if  
parts of  
parts.  
positive  
6 per ce  
of gasol  
ditions,  
an explo  
Gove  
1  
Some of  
Cause  
The go  
ine does  
trouble,  
trouble is  
There  
ors in co  
engines,  
governor,  
error. I  
principle  
balls are  
action acc  
weights a  
trifugal fo  
the higher  
throw  
weights n  
shaft or m  
Springs h  
that the ee  
be too gre  
of the engi

**Some Hazards in Handling Gasoline—When it is Dangerous and When it is Not**

In connection with investigations regarding safety and efficiency in the use of petroleum and its products, the bureau of mines has made numerous tests of gasoline.

Gasoline vapor mingles with the air in the same manner that water vapor does, the amount carried depending upon the temperature of the air and the readiness with which the vapor can be obtained. If one takes the cover off a full pail of tightly enclosed gasoline and applies a match to the surface, the gasoline will flare up and burn as long as the gasoline lasts. On the other hand, if one puts a few drops of gasoline in a small tightly enclosed pail, waits a few minutes and then produces a flame or electric spark, a violent explosion will likely result.

In the first case the vapor burns as fast as it comes from the gasoline and mixes with the oxygen of the air, whereas in the second case the oil vaporizes in the pail and mixes uniformly with the air to form an explosive mixture and upon ignition, explodes.

One gallon of gasoline when entirely vaporized produces about 32 cubic feet of vapor. If a lighted match could be applied to pure gasoline vapor in the absence of air, no fire or explosion would result. At ordinary temperatures air will hold from 5 to 28 per cent of gasoline vapor, depending upon the grade of gasoline. In 100 parts by volume of air and gasoline, an explosion would not take place if there were more than 6 parts of gasoline, or less than 1.4 parts. In other words, the explosive range is between 1.4 and 6 per cent of vapor. One gallon of gasoline can, under ideal conditions, render 2,100 cubic feet of an explosive mixture.

**Governor Must be Right if Engine's Efficient**

*Some of the Things Which Will Cause a Governor to Fail to Do Its Work*

The governor of a gasoline engine does not usually give much trouble, yet when it does, the trouble is usually serious.

There are two types of governors in common use on gasoline engines, viz., the hit-and-miss governor, and the throttling governor. Both act on the same principle in so far as weights or balls are used to regulate the action according to speed. These weights are thrown out by centrifugal force when set in motion, the higher the speed the greater the throw of the weights. The weights may be on a separate shaft or mounted in the fly wheel. Springs hold the weights in so that the centrifugal action will not be too great. Hence, the speed of the engine may be regulated by

changing the tension of these springs.

The hit-and-miss type of governor regulates the engine by holding the exhaust valve open when the engine is running slightly over speed. As the weights are thrown out, the governor sleeve moves so as to press a detent arm toward the exhaust valve rod which then engages in a notch or detent on the exhaust valve rod, holding it open until the speed of the engine has gone down to normal.

The throttling governor works in very much the same way, but the movement of the sleeve is transferred through a lever to the throttle, thus partially shutting off or throttling the mixture as it enters the engine.

In either type of governor, if the weights, sleeve and arm are not working properly, irregularity in the action of the engine will result. Sometimes we find a spring has been lost and the weight is wired in place. This partially or completely destroys the action of the governor. The fly wheel may have slipped on the shaft, causing the arm to cease to act on the detent. Then the engine will run away. The same effect may be produced by accidental bending of the arm. Of course, the opposite effect may be produced by either of these troubles, causing the engine to run too slow or to refuse to run. An engine is balanced to run at a certain speed, hence should not be made to run much above or much below this speed.

**Alberta Grown Timothy Seed Makes a Hit**

Six cars of the best timothy seed that has been on the Toronto market for years recently arrived from the province of Alberta. Practically all this seed is bold and plump in berry, bright in color and remarkably free from impurities. Some of it, unfortunately, was considerably hulled, due to over-ripeness before being cut and to standing too long in stook before being threshed. Farmers in the prairie provinces, who have land that is naturally too rich and too moist to mature cereal grains, would do well to take up the production of timothy seed on an extensive scale. Six cars of timothy seed is a very small part of the requirements of the Toronto market. The duty on timothy seed imported from the United States amounts to seventeen and a half per cent. If the prairie provinces will produce from five hundred to six hundred cars of timothy seed per year, this will go far towards curtailing the importing into Canada of seed now grown in the Mississippi valley on land valued from \$75 to \$150 per acre.

**MINNEAPOLIS**

**A  
C  
H  
I  
N  
E  
R  
Y**

**A  
T  
I  
S  
F  
I  
E  
S**

**Steam Engines**

are well and favorably known in all grain growing sections of the United States and Canada.

Boilers are extra large, full water bottom type and very free steamers. Economical in consumption of fuel and water—easy to operate and durable.

**1916 Catalog** shows exclusive features that will be interesting to particular threshermen.

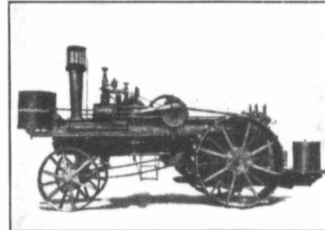

**Single Cylinders**

In Sizes

- 16, 18,
- 20, 22,
- 25, 28,
- 34 H. P.

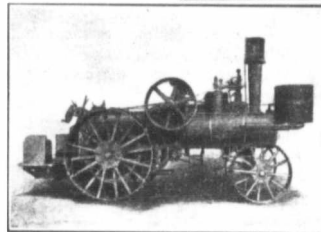

**MINNEAPOLIS**

**M  
O  
D  
E  
R  
N**

**S  
E  
P  
A  
R  
A  
T  
O  
R  
S**

**Separators**

are popular because they are satisfactory to thresherman and farmer alike — close savers, good cleaners.

**Run Steady and Ever Ready —**

**Our Customers Are Our Referencences.**

Booklets filled with testimonials from your own section of country mailed free.

Ask for "Satisfaction"

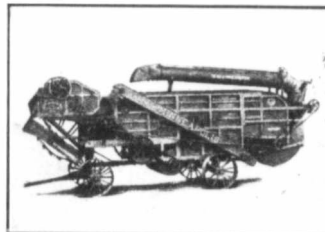

- Tool Steel Teeth**
- Self Oiling Cylinder Boxes**
- Double Chaffer**
- Low Down Elevator**
- Light Running and Strictly Up-to-Date**

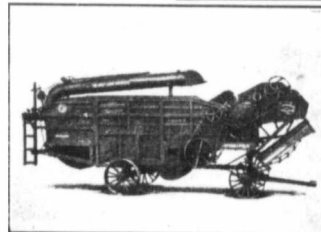

**The Minneapolis Threshing Machine Co.**  
Builders of "The Great Minneapolis Line."  
WEST MINNEAPOLIS (Hopkins P.O.) MINNESOTA, U.S.A.,  
Branches: WINNIPEG, REGINA

# Does the Light Gas Tractor Solve the Farm Power Problem

By  
A. C. CAMPBELL

**B**Y the light tractor we mean the small machines designed to pull 2 or 3 plows and rated at from 8-16 horse power to 10-20 horse power. A few years ago we thought that the large gas tractor of 60 or 80 brake horse power was the solution to our power problems. There was a great demand for these big strong machines, and the bigger they were the better they were liked. If one farmer got a tractor which could pull 8 plows, his neighbor wanted one to pull 10 plows. Much money was invested in these power giants weighing from 25,000 lbs. to 30,000 lbs. and many good farmers lost all they had as a result of failure to make these extremely big tractors profitable.

After a time there was a lull in the gas tractor business. 1913 and 1914 were quiet years, but now we see large numbers of farmers purchasing and preparing to purchase the new light tractors and we ask ourselves the question above.

The writer has watched the development of the gas tractor since it was first introduced, and it has been part of his business to keep himself well posted on the various types of tractors produced.

One thing which strikes us at first glance when we size up the average small tractor is its extreme lightness per plow pulled. We have to-day tractors being offered for sale, weighing from about 3,500 lbs. to 5,000 lbs., for which the makers claim ability to pull 2 to 4 plows, according to soil and other conditions. To pull a 3-furrow plow with horses under average conditions, we require at the very least 6 horses and they would have to be good ones. If we used 6 horses weighing 1,400 lbs. each we would have 8,400 lbs. of horse flesh.

It is our opinion that there has never been a tractor wheel or substitute for a wheel designed, which equals the tractive efficiency of a horse's feet and legs, yet we are asked to believe that 4,000 lbs. of tractor will exert as great a drawbar pull as 8,400 lbs. of horse flesh. We do not consider this possible except where conditions of footing are ideal.

Those of us who followed the records of the many engines, which competed in the Winnipeg motor contests, learned, among other things, much about design and construction. We learned that an efficient tractor must

weigh around 2,000 lbs. per plow pulled and must carry 75 per cent to 80 per cent of this weight on the drive wheels. This would go to show that a 3-plow tractor should weigh at least 6,000 lbs. A powerful motor is of no use on a tractor unless the tractor is of sufficient weight to hold the drive wheels down to their work and thereby permit of the power being delivered at the drawbar.

The great variety of design in light tractors is in itself fairly good proof that the problem is not yet solved and that the light tractor is still very much of an experiment. Until the designs are somewhat standardized, as is the case with the larger machines, we must look upon these light tractors with suspicion.

In looking over the illustrations accompanying the article



How is this for "Power Economy?" Four men and four horses to an 8ft. Seeder!

on light tractors, which appeared in *The Thresherman* of last September, the writer has observed that of the many tractors represented, only about 27 per cent are built by well-known tractor builders, and of these 27 per cent, half can hardly be classed as small tractors. This shows that "mushroom" firms with practically no reputations, are the principle builders and vendors of light tractors.

Until recently most of the well-known builders kept strictly out of the light tractor business and only came into it finally when they realized that the farmers were going to buy light tractors in spite of them and that they would lose considerable business if they did not build light tractors. Even to-day many of the old firms refuse to build and sell these light tractors, which fact is in itself significant.

Manufacturers sometimes have to build what the people want, rather than what they, the manufacturers, believe to be right.

The automobile business to-day plainly illustrates this point. We see a growing demand for 6, 8, 12

and even 16-cylinder motors and as a result a growing supply of them. These machines are built because the people want them rather than because the designers believe in them. Look at the racing cars of to-day, most of them 4-cylinder machines, showing that this type of motor is still believed to be the best.

Light tractors are built and sold because the farmers want them and not because engineers and designers really have faith in them. As already mentioned, we find a great variety of design in light tractors, yet, in looking over the medium sized and large tractors we find them all practically the same in some respects at least. The types of motors are many, yet the method of mounting and transmitting the power to the drawbar is fairly

well standardized. We find these machines equipped with 4 wheels, 2 drive wheels behind and 2 front wheels, and they all have differential gears, etc.

Another type of design in light tractors, yet, in looking over the medium sized and large tractors we find them all practically the same in some respects at least. The types of motors are many, yet the method of mounting and transmitting the power to the drawbar is fairly

ers have tried to overcome the tendency of this type to crowd away from the driver side by providing a dog clutch to drive from the other rear wheel when desired, but just the instant they drive from both wheels the centre of draft of the engine is moved to a point somewhere between the two drivers, and again they have side draft. When using the dog clutch they also have a 2-wheel drive without a differential gear, which is a joke.

Another type of 1-wheel drive has the drive wheel at the centre rear of the tractor and 2 wheels in front. This would look better were it not for the fact that with this type of truck we must place the motor in front of the drive wheel, which of course throws much of the weight on the front wheels. A number of light tractor builders aggravate this trouble by using opposed motors, whereas we should have 75 per cent to 80 per cent of the total weight of a tractor over the drive wheels to get tractive efficiency.

We could take up many other types but our idea is simply this. If it has been found necessary to equip large and medium-sized tractors with 4 wheels (two of which are drivers), differential gears, etc., it is just as necessary on the light tractor. If the larger tractors should weigh 2,000 lbs. per plow pulled, and have 75 per cent to 80 per cent of this weight on the drivers, the same rules should hold good in building light tractors. If these and other rules were followed, a good small tractor weighing about 6,000 lbs. could be produced but the price would be prohibitive when compared with the price of the cheaply constructed light tractors now on the market.

Threshing is a problem which presents itself to the light tractor owner or prospective owner. He wants to know what size of separator equipped with blower, feeder and weigher the tractor will drive, and our experience is small for the 8-16 or 10-20 tractor possibly an 18-inch cylinder. Are we going to come to using this size of machine? We think not.

There is no doubt in the writer's mind as to the growing demand for light tractors and a lot of money will be invested in them this year, but we are afraid that a larger percentage of the machines will prove to be unsatisfactory and will find resting places in the fence corners.

Continued on page 26





RUMELY

GAAR-SCOTT

ADVANCE

# As to Your Threshing Outfit This Year

ONE of the good things about Advance-Rumely threshing machinery is that you have three standard lines to choose from, Rumely, Advance and Gaar-Scott—there's a type and size to meet your own particular requirements.

Best of all, you can rely on any one of these three lines—not just because we say so, but because you threshermen yourselves have proved their dependability by years of actual field work under all conditions.

Profits from threshing are made only with machines that stand up to the work and don't eat up the dollars in lost time and continual repairing.

You'll find that threshermen who own Rumely, Advance or Gaar-Scott outfits

are the ones who please their customers and are asked to "come again next year." Why? Because they deliver 100% on the job in fast, clean work—they put the grain in the sack instead of the stack, and there's no loss of time and money in breakdowns and delays.

Again we say, it's not only our word you have for it—the proof is in the facts, and actual experiences of threshermen in all parts of the country.

Back of Rumely, Advance and Gaar-Scott engines and separators is a combined experience of over seventy-five years in the successful manufacture of threshing machinery. If threshing outfits could be made better you'd get them in Rumely, Advance and Gaar-Scott.

You can be absolutely sure that any one of these three lines will "deliver the goods" and you can count on Advance-Rumely service at all times.

To start with, write our nearest branch for catalogs which completely describe the construction and operation of these three lines.

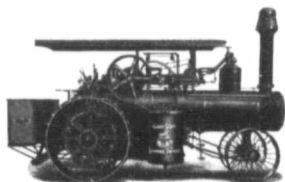

Gaar-Scott 25-H P Engine

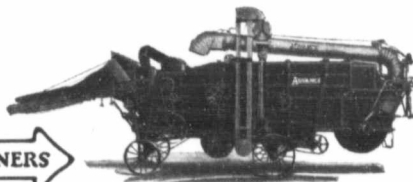

Advance Separator



## ADVANCE-RUMELY THRESHER CO.

(Incorporated)

La Porte

Indiana

### ADVANCE-RUMELY BRANCHES:

Aberdeen, S. D.  
Battle Creek, Mich.  
Billings, Mont.

Dallas, Texas.  
Des Moines, Iowa  
Fargo, N. D.

Kansas City, Mo.  
Lincoln, Nebr.  
Madison, Wis.

Nashville, Tenn.  
New Orleans, La.  
Peoria, Ill.

San Francisco, Cal.  
Spokane, Wash.  
Wichita, Kans.

Columbus, Ohio

Indianapolis, Ind.

Minneapolis, Minn.

Portland, Ore.

Calgary, Alta.

Saskatoon, Sask.

Regina, Sask.

Winnipeg, Man.

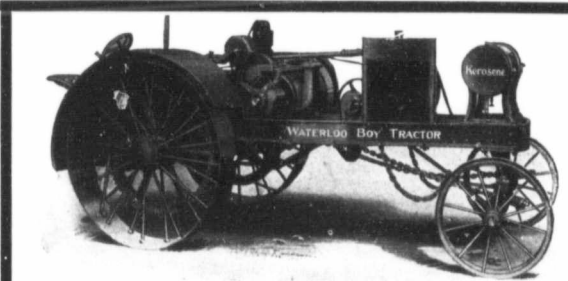

Weight only 4,800 lbs.  
 Brake Test, 21 h.p.; Draw Bar, 12 h.p.  
 It is a Kerosene Tractor, built especially to operate on the heavier fuel.  
 It has Twin Cylinders, cast on block.  
 Ignition — High Tension Dual Magneto, with Automatic Spark Advance.  
 It has a Cooling System of the most approved type.

When plowing, is Self-Steering, and will turn in a 25-ft. radius.  
 Easy to operate—Economical on fuel.  
 All working parts are very accessible and easily kept in perfect adjustment.  
 Transmission—Sliding Gear, with Shifts for one speed forward and one reverse.

Gasoline at the end of January, 1916, was 31½¢ per gallon. The price of gas is soaring all the time. It is highly probable that it will touch the 50¢ per gallon mark before the end of the year, and at a time when you will want it most. When you buy a tractor you need to figure out the cost of operation. Fuel should be one of the chief determining factors. The initial cost of the tractor itself is but a minor consideration. With the positive advance of gasoline, farmers will naturally turn to a low-grade oil as a substitute. The Waterloo Boy One-Man Tractor, which is especially constructed to operate on low-grade oil, will give gallon for gallon equal and even greater efficiency at a consequent lower cost per acre. It should not be overlooked that **The Waterloo Boy is a Kerosene One-Man Tractor, and we guarantee it to fulfill every requirement we claim for it.**

The Waterloo Boy will pull a light engine gang with three 14-inch plows in stubble any depth you wish. It will pull two 14-inch plows in any prairie breaking. On your summer fallow it will handle a disc with barrows behind at from 2½ to 3 miles per hour. It will drive a 24-46 thresher with all attachments at a capacity of 700 bushels of wheat to 1,400 bushels of oats per day. The Waterloo Boy performs this work with efficiency, economy and durability. All in all, it is Special Value. Under the circumstances it will pay you to obtain full information, price, etc. Mailed free. Write us today. We are hand-ling Gas Engines, Grain Grinders, Cordwood and Pole Saws, Electric Lighting Machinery, Hand and Power Washing Machines, Grain Elevators, Pump Jacks, Small Threshing Machinery, Betting and Threshers' Supplies. Live Dealers wanted in Territory Where We are Not Represented.

**THE GASOLINE ENGINE AND SUPPLY CO. LIMITED,**

**104 Princess Street, WINNIPEG**

## GASOLINE IS GOING UP!

That is why you should be interested in

# The "Waterloo Boy"

## Kerosene One-Man Tractor

*The Manufacturers' Guarantee Fully Protects You*

The Gasoline Engine and Supply Co.,  
 Winnipeg, Man.

Noremac, Sask., Jan. 4, 1916.

Dear Sirs:—In reply to your enquiry as to my experience with the Waterloo Boy Tractor, I wish to say that I unloaded the machine at Kindersley and drove it home 30 miles. I then broke about sixty acres of very heavy land. You may judge for yourself when I say we always use 5 horses on one 14-inch plow. I pulled 2 14-inch plows at a depth of 4½ inches, which would mean a good ten-horse load, using four and a half gallons of kerosene per acre and barely a quart of Standard Gas Engine oil per day. I then disc'd the land, made two trips to Kindersley. In one case I hauled 310 bushels of wheat on three wagons and one empty oil tank behind, returning with three wagons loaded with lumber and oil tank containing 450 gallons of kerosene, using large plow, making an average speed of three miles per hour.

After threshing my grain, I hauled it with two grain tanks up several steep hills to the elevator. In all, my roadwork would amount to about 250 miles.

I never had an expert, not even to start the engine. After looking at the connecting rod bearings, I took a thin piece of brass out and the other would not stand taking up at all. I never touched the main bearings and never had to tighten up a nut on the frame since I got it.

I have now enlisted to go to the front, and found no difficulty in disposing of my tractor for \$900.00, and can thoroughly recommend it to any person intending to buy.

Yours very truly, (signed) JAMES H. CRUBB.

As you wish, it will pull two 14-inch plows in any prairie breaking. On your summer fallow it will handle a disc with barrows behind at from 2½ to 3 miles per hour. It will drive a 24-46 thresher with all attachments at a capacity of 700 bushels of wheat to 1,400 bushels of oats per day. The Waterloo Boy performs this work with efficiency, economy and durability. All in all, it is Special Value. Under the circumstances it will pay you to obtain full information, price, etc. Mailed free. Write us today. We are hand-ling Gas Engines, Grain Grinders, Cordwood and Pole Saws, Electric Lighting Machinery, Hand and Power Washing Machines, Grain Elevators, Pump Jacks, Small Threshing Machinery, Betting and Threshers' Supplies. Live Dealers wanted in Territory Where We are Not Represented.

Continued from page 24

A light tractor used to displace portable and stationary engines of, say, 12 or 15 horse power, will no doubt be all right but as a plowing and threshing proposition it does not appear to be practicable.

The big tractor had its day and now the light tractor will have its day, which we believe will be even shorter than that of the big tractor, and finally will get an engine, a happy medium, which will fill the bill.

In arriving at a decision as to what size of tractor would be most suitable for all conditions, the writer has assumed that plowing and threshing would be its principle uses. Experience shows us that a 28-inch cylinder is as small as is satisfactory under present conditions. To drive this machine in all kinds of grain under any conditions, we require at least 30 brake horse power.

We therefore say that the ideal general purpose tractor will be an engine of 15 drawbar horse power and 30 brake horse power, capable of driving a 28-inch cylinder thresher or hauling four or five 14-inch stubble plows, and weighing in the neighborhood of 10,000 or 12,000 lbs.

An engine like this will go a long way towards solving our power problems and will finally displace both the very large tractor and the very small one.

Go at your work each day as though it were your first day in a new job and you had to make good.

### Why Some Dry Cells Use Up Quickly

E. R. Wiggins

The greatest cause of trouble found for cells running down quickly during the operation of the engines is with contact coming too early on make-and-break engines, and with jump spark the contact being for a longer period than is necessary. On make-and-break engines the practice is to have the point of contact occur from sixty to ninety degrees in advance of the point of ignition. That is to say, the crank pin is in a position sixty to ninety degrees ahead of where the crank pin is when the spark occurs on the cylinder. By contact is meant the position of ignitor when the points first touch each other. The reason for having the point of contact at least sixty degrees in advance is this: Electric current is almost instantaneous in its travel, but not quite so, and it does take some time for the current to build up and flow steadily and have the condition which is analogous to momentum. To illustrate, when a water faucet is opened and closed suddenly, the water hammer or knock in the pipe is not as great as it is when the faucet is opened, and the water allowed to run for a time and then suddenly closed. Then, also, the period of time that it takes the crank pin to travel through an arc of sixty degrees is very small. To illustrate, take the case of a 4½ in. x 7 in. engine running at a speed of 400 revolutions per minute. This means a speed of 6.6 revolutions per second, and calculation shows

that it takes 1-208 of a second for the crank pin to travel sixty degrees, which is not very long when a person stops to think of it. But this is good engine practice, and really gives the best results.

Suppose, however, contact comes and occurs through a period of one hundred and thirty degrees or even more, the circuit will then be closed through twice as long a period and the life of the cells will be shortened somewhat in the same proportion. The point of contact then is of great importance and the adjustment on this should be carefully looked after. One company's standard on this is to have what is called "ninety degrees contact." Contact occurs when the crank is in a position straight down, on horizontal engines, and as the point of ignition is from fifteen to thirty degrees in advance of the crank and dead center a contact of at least sixty degrees is always maintained. The position of contact is regulated not by moving the cam gear a tooth or two, but by moving the igniter trip along the exhaust push rod or with some engines by moving forward the igniter trip disc. The tendency is for the point of contact to become later and later as the engine grows older and the trip wears.

With the jump spark engine contact must not come too early because if such were the case the engine would stop because of too early ignition. The trouble with the jump spark engine contact is that due to mal-adjustment or wear. The part pressing against



# GASOLINE

We are refiners and Manufacturers of Gasoline, Coal Oil, Distillate, and all Petroleum Products

Let us quote you on any quantity from a can to tank car

# OILS

**Continental Oil Co. Ltd.**  
 WINNIPEG

Branches: Brandon Regina Saskatoon Swift Current Calgary Lethbridge

the disc to close the circuit, may remain in this position after the charge in the cylinder has been fired, and thus the cells will be depleted more than is necessary. With a jump spark engine it is best to use as few cells as will do the work. Connect just enough cells together to get a good buzz on the coil, more cells are really unnecessary.

The writer believes that more trouble with cells using up too fast

comes contact An ex of this the con tion. I agemer not left opened idle.

Direct A S P annual e in the bushels which States, seed in States fr 15,000,0 amount, brought and is e time. The price of United S in Canad the avail countries charges. by the er least the

# International No. 2 Cultivator

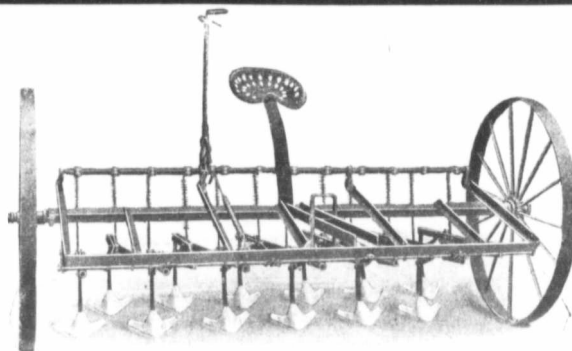

**T**HIS most useful and profitable implement—the International No. 2 cultivator—will do good work on your farm. It serves the double purpose of cultivating your soil and thoroughly ridding the ground of weeds. For forming a mulch of dirt to conserve moisture, for keeping down obnoxious weeds, for summer fallowing, you could not own a more economical implement.

The main frame of the INTERNATIONAL NO. 2 is of angle steel, more than strong enough to keep the teeth at their work in all conditions of ground. The teeth follow the unevenness of ground, being independent of each other. They cannot twist out of position and strong springs protect them. One easy-working lever and rock shaft controls the cultivator. Note the steel wheels and axles—only the International has them.

Either spring or stiff teeth are furnished. At little added cost you can have both sets, giving you a splendid outfit for all-round use. The stiff teeth cut the whole surface of the ground. They are excellent in getting rid of thistles and woody-stalk weeds. The spring teeth points are reversible, giving double wear. The cultivator can be equipped with grain and grass seeding boxes.

See the agent who sells the International No. 2. Write the nearest branch house for catalogue.

## International Harvester Company of Canada, Ltd.

### BRANCH HOUSES:

At Brandon, Calgary, Edmonton, Estevan, Hamilton, Lethbridge, London, Montreal, N. Battleford, Ottawa, Quebec, Regina, Saskatoon, St. John, Winnipeg, Yorkton

comes from too long a period of contact than from any other cause. An expert sent out on troubles of this kind should look first to the compact and then to the insulation. Short circuit and poor management, in seeing that cells are not left dry and the switch not opened when the engine stands idle.

### Flax for Grain

By J. H. CRISDALE,

Director Dominion Experimental Farms

**A**S a crop likely to be quite as profitable as wheat this year may be mentioned flax. The annual consumption of flaxseed is in the neighborhood of 30,000,000 bushels on this continent, of which all but about 2,000,000 bushels is used in the United States. The combined crops of seed in Canada and the United States fall usually 12,000,000 or 15,000,000 bushels short of this amount. This extra seed is brought normally from Argentina and is coming in at the present time.

The factors controlling the price of this commodity in the United States and consequently in Canada at the present time are the available supply in accessible countries and transportation charges. The supply as furnished by the crop of 1915 is short at least the usual amount as men-

tioned above, and the high cost of ocean transportation at present (about 70 cents per bushel from Buenos Ayres to New York), has had the natural effect of raising the price of every bushel of seed on this continent, so that now, instead of 70 to 80 cents per bushel, as was the price at Winnipeg in 1912, \$2.20 to \$2.25 per bushel is being paid at the same point.

The soil and moisture requirements for a good crop of flax are so nearly the same as for a good crop of wheat that the average farmer this year is likely to sow to wheat any land that under somewhat different circumstances might have been sown to flax. Flax must have a goodly amount of moisture either in the soil (as in summerfallow), or as rain in June and July to insure anything of a crop worth while. Further, it must be sown on fairly clean land and it must be sown early enough to allow it to ripen before fall frosts, but not so early as to run any risks from spring frosts once it has thrust its first tiny leaves above the ground. This means sowing anywhere from May 15 to June 1 in Saskatchewan and northern Manitoba, from May 10 to June 10 in southern Manitoba, and from May 10 to June 3 or 4 in southern Alberta.

Where wheat seeding has pro-

gressed rather slowly it will often be advisable to sow the last few acres intended for wheat to flax. The cash returns per acre from the two crops are likely to be practically equal this year and will probably be about the same as they were last year. For this reason it is well worth trying the flax and running no risk with late wheat, which is usually a poor crop at best.

A few points in connection with the production of a crop of flax are therefore worth considering at this time.

**Seed**—The seed, as available at the elevator or at the farmer's granary is very often badly polluted with weed seeds. Seed in this condition should not be sown under any circumstances. Cleaning the seed is difficult, but only clean seed should be sown and that on clean land. A limited area

of well prepared land sown with clean seed will be more profitable than a large area of badly prepared land on which dirty seed is used.

**Seed-bed**—Well prepared land means:—

- (a) A good summerfallow.
- (b) First year stubble after summerfallow properly burned, well cultivated, sown and then harrowed.
- (c) Other stubble land burned if possible, well ploughed, then packed, harrowed and seeded, and then packed again, or rolled and harrowed.

This latter preparation may give a good crop if fair rains come, but will most certainly give a poor crop if the season is dry, not because of the special preparation mentioned, but because of the scarcity of moisture in the soil on account of the crop

## Breakages <sup>Welded</sup> by **Oxy-Acetylene**

impart a strength to the machine greater than it ever possessed, while the job is the most finished bit of work ever attained in repairing a fracture.

### WE ARE THE PIONEERS OF THE PROCESS

ARE EXPERTS IN EVERY DETAIL OF OXY-ACETYLENE

If anything breaks or is worn out on your threshing machine or traction engine, have it welded by the Oxy-Acetylene process.

**YOUR BLACKSMITH OR REPAIR EXPERT CAN DO THIS WORK FOR YOU**  
See him now about your broken castings. If he has not a welding plant write us, giving his name, and we will supply him with full particulars. It will save you time and money.

**L'Air Liquide Society,** 328 William Avenue, WINNIPEG, Man.

Largest Manufacturers of Oxygen and Welding Plants.

grown in past years, particularly in 1915.

For the new settler or the man with new breaking done before May 25 or 26, flax offers an opportunity for money-making this year on this land as it is not possible with any other crop.

Breaking about 3 inches deep, discing as soon as broken, so as to fill all openings or spaces between the furrows, and to conserve any available moisture as well as make a solid seed-bed, will be such a preparation as gives a fair chance of a fair crop of flax if good seed is carefully sown before the first of June. Sow seed at the rate of 30 to 40 lbs. per acre. Sow only clean seed and if clean seed is important on old land it is doubly important here, since the whole future of the field may be ruined by putting on dirty seed at this time.

**Conclusion**

Prices for flax are likely to be good this coming fall, so where conditions are favorable, or where circumstances suggest flax it will quite likely be wise to grow this crop, being careful always to sow only good seed on a thoroughly prepared seed-bed, under the conditions and at the time above specified.

**Crop Production on Stubble Land in 1916**

By J. H. GRISDALE,

Director Dominion Experimental Farms

The outlook for a bumper crop in 1916 is not as good as we, as Canadians, would like. Unfortunately, also, the scarcity of farm labor in these provinces is likely to quite seriously limit the amount of work to be done on the land in the short time from frost-out permits till "seeding-time past" ends the rush.

However, there is another side to the matter. In the first place, prices for all grains and forage crops are practically certain to be high next fall. And to this the certainty that as a Dominion, as a part of the British Empire and as a nation at war, we do very certainly need every last bushel of grain and every ton of produce of every kind our farms can produce this year, 1916. With the double incentive of material benefit to the individual and patriotic service to the nation we should supply, every farmer of us, make every possible effort to achieve this double end. It is wonderful what early and persistent effort on well-planned lines will do toward getting a large area of land properly under crop in the four to six weeks that seed-time on the prairie usually lasts.

May I offer a few suggestions

1. *Get the seed ready.* Sow a pure variety if possible. Clean it thoroughly. Sow no weed seeds.

Sow no light kernels this year. Light grain means weak, slow growth, fan it to a finish. Make preparations to treat for smut.

2. *Get the horses and harness into good shape.* Ill-fed horses and poorly-kept harness are a bad combination with which to begin work. Feed the one and mend and oil the other now if not already done, as should be the case.

3. *Have all machines in good shape.* Have a few spare parts on hand. Half a day's hold-up at seed-time may quite possibly mean a hundred dollars' at harvest. Is it worth while running the risk if a little forethought will prevent the same?

4. *Get the seed sown on the summer-fallow as soon as the land is fit* but do not wait for the summer-fallow if stubble is ready first.

5. *Seeding the stubble land is,* however, the operation needing the most thought this spring. Let us consider it.

Before beginning this article, we took the precaution to communicate with our officers, Angus Mackay, Esq., the General Superintendent of Western Farms, the Superintendents at the Experimental Farms at Brandon and Morden in Manitoba; at Indian Head, Rosthern and Scott in Saskatchewan, and at Lethbridge and Lacombe in Alberta. The suggestions offered are really an epitome of the recommendations of these men for the districts served by these farms respectively. These recommendations are based on actual conditions at the end of February, 1916, in these same districts centred round the points mentioned.

(a) *Handling Stubble Land of First Chop After Summerfallow*

The stubble on such land is usually heavy and burns readily. In many parts it was left unusually heavy last fall and so will burn unusually well this spring. Fire about noon time, the first warm day in April after the surface of the soil is dry and when a strong steady wind is blowing. Spare no pains to insure a good burn even if prospects do look good. Cultivate at once about 2 inches deep, then sow the wheat and harrow afterwards. Lose no time here, if the area burned over is very large, it would pay to first harrow right after the burn in order to conserve moisture, then cultivate seed and harrow again.

Sow about 1½ bushels per acre in the eastern part of Saskatchewan, but only about 1¼ bushels per acre in the western part, reducing the quantity by about ¼ bushel per acre in either case on light soils or if the land is particularly dry.

These suggestions as to treatment of stubble land of the first crop after summerfallow hold good this year throughout the prairie provinces.

**Western Canada Fairs Association**

D. T. ELDERKIN, Regina, PRESIDENT.

W. J. STARK, Edmonton, SECRETARY.

**\$150,000.00**

**IN PRIZES AND PURSES**

**Circuit for 1916 Exhibitions:**

		Manager
Calgary	June 29 to July 5	E. L. Richardson
Red Deer	July 6 to 8	G. H. Lindsay
Edmonton	July 10 to 15	W. J. Stark
Brandon	July 17 to 22	W. I. Smale
Regina	July 24 to 29	D. T. Elderkin
Saskatoon	July 31 to August 5	C. D. Fisher
North Battleford	August 7 to 9	F. Wright
Prince Albert	August 10 to 12	W. O. McDougall

Write the Managers for prize lists, entry forms and other information. Race programmes will be supplied by the Secretary, W. J. Stark, Edmonton.

**YOU** can save real dollars every day you use the tractor, by burning kerosene as a fuel in the place of gasoline.

If kerosene has not given you perfect success in the past, write to your tractor manufacturer for suggestions---and be sure you get the clean-burning, powerful, uniform SILVER STAR KEROSENE or ROYALITE COAL OIL, the standard tractor fuels of many years. Our tank stations, located throughout the West, will supply them and save you money.

**THE IMPERIAL OIL COMPANY**

Limited

BRANCHES THROUGHOUT CANADA

**We are Waiting**

For your estimate on the number of kernels in 3¼ pounds of No. 1 Northern Wheat. You take no chance whatever. The Magazine is worth considerably more than what you pay for it, and the \$725.00 Chevrolet Car---well, "nuff said."

(b)  
A  
sum  
year  
certs  
crop  
usua  
this  
a rel  
merf.  
this  
burne  
ing st  
ing 4  
wrap  
about  
them  
open  
drops  
stubble  
If  
impos  
thoron

**M  
T**  
Fal  
AT LA  
NO  
Th  
WINN

# The Farmer's "Right Hand"

A farmer's Right Hand is the most valuable implement on the farm. But the hand can only do one thing at a time, and it gets tired. Think of having a right hand that never gets tired and is as powerful as 20 right hands, and when it is busy, leaves the owner free to use both his hands at other work. If a farmer has to Pump Water for house and for cattle, Grind Feed, turn the Cream Separator, turn the Churn or the Washing Machine, and if he has to Saw Wood according to the good old buck-saw fashion, what time does he have for fixing up fences, painting, shingling and the endless amount of repairing that is necessary on buildings and implements? Such a farmer is a drudge of the worst kind, unless he has a CHAPMAN Engine and the necessary labor-saving equipment to make life worth living. We not only sell the Chapman Engine but we handle the highest class Pumps of all kinds, Grinders, Silo Fillers, Well Drills and Saw Frames. Our equipment saves so much time it pays for itself the first year.

## Chapman Engine

### THE FARMER'S RIGHT HAND.

Made in 2 h.p., 5 h.p., 7 h.p., 10 h.p. sizes. Solid and simple, containing the fewest parts, the most direct action and the most substantial construction. Developing more than rated h.p., 250 to 400 r.p.m., extremely light on gasoline, with fly ball governor to regulate speed and non-leakable fuel tank, and sufficient weight to make it absolutely steady. The Chapman Engine is so good that others try to imitate it, but our best points are covered by patents, and they can only be found exclusively in the Chapman Engine. Write for full particulars of size, weight, speed, power, prices, etc.

fuel, cylinders kept at right temperature for perfect volatilization, straight line valve motion, and non-leakable fuel tank, and sufficient weight to make it absolutely steady. The Chapman Engine is so good that others try to imitate it, but our best points are covered by patents, and they can only be found exclusively in the Chapman Engine. Write for full particulars of size, weight, speed, power, prices, etc.

CATALOG FREE—WRITE FOR IT.

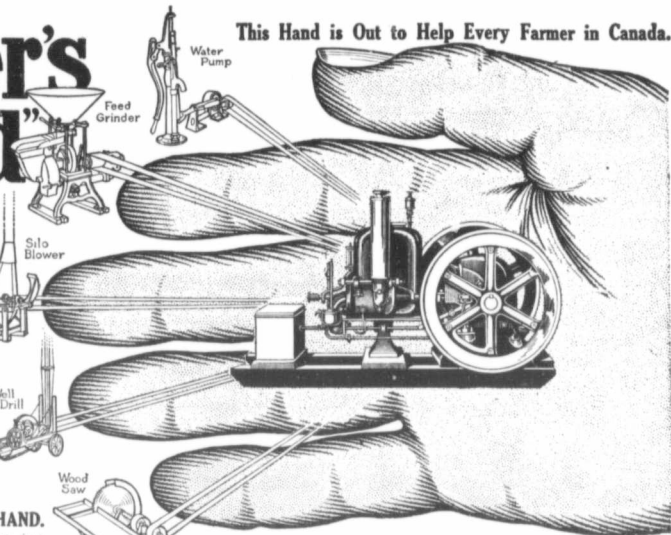

This Hand is Out to Help Every Farmer in Canada.

YOU can dispense with your hired man when you have an Engine with Grinder, Saw, Silo Filler, etc. You will save the cost of your entire outfit the first year. If you will tell us how many head of cattle you have, we can tell you what size grinder, what size silo and blower, what size pump and engine to get. There's no economy in buying an engine too small and there is no advantage in buying one too big. Tell us all about your engine needs and let us advise you.

## Ontario Wind Engine & Pump Co. Limited

73 ATLANTIC AVE., TORONTO

Branches: Montreal, Winnipeg, Regina, Calgary.

### (b) Handling the Stubble Land of the Second Crop after Summerfallow

As a rule, such land should be summerfallowed each year. This year, however, it is just possible a certain proportion of it should be cropped, since there was an unusually large area of crop sown on this kind of stubble last year and a relatively small area under summerfallow. If it is to be cropped this year, the stubble should be burned if at all possible, scattering straw freely over the field, using gasoline torches made by wrapping old sacking round sticks about 4 feet long, then dipping them into gasoline carried in an open pail and shaking burning drops of gasoline on the straw and stubble.

If stubble is so light as to be impossible to burn, then cultivate thoroughly, harrow right after cul-

tivating to bring the stubble on top, then seed. Sow quantities of wheat somewhat less than on first year stubble mentioned above. It is, however, practically never advisable to sow wheat on second year stubble; oats or barley being likely to give much better results. Sow oats on the land first ready and barley on the later land.

If shoe drills are used, ploughing instead of cultivating is practically a necessity to prevent dragging of stubble, etc. Ploughing is also indicated if land is at all grassy or very weedy. Pack or roll and then harrow right after ploughing in every case.

### (c) Handling the Stubble Land the Third Year after Summerfallow

Such land should never be sown to grain but should be summerfallowed without fail.

As a rule, one third of the cropping area in Saskatchewan and Alberta should be in summerfallow each year, and this year should be no exception. Even should an early season make it appear that in spite of little fall preparation it will be possible to get practically all the land under crop this year, such should not be the plan.

The plan should be rather to get, say, two-thirds into crop with preparation and seeding well done and then prepare to summerfallow the other third. The probabilities are that such a policy will give by far the best results throughout Saskatchewan and southern Alberta, even this year,

and very certainly the prospects for 1917 will be tremendously improved thereby. In northern Alberta and in Manitoba, however, it is quite possible that a considerably larger proportion of the land might be cropped profitably in 1916, if time for fair preparation permits.

Even here, however, and more particularly in southern Manitoba, such land should be cropped only after ploughing. Plough, disc, and seed the same day if possible, or at worst leave but a very short time after ploughing. A shallow furrow will sometimes prove better than a deep one, but it is usually safer to go 5 inches or 6 inches down.

### The Summerfallow Area in 1916

As already indicated, the summerfallowing of a goodly acreage each year is an important matter.

Such treatment is a practical guarantee, an insurance of a crop for the succeeding year, no matter what the weather that year, as many who suffered in 1914 in southwestern Saskatchewan and southern Alberta will admit. Here is an example of what it means. The writer in the course of a rather extended trip through the district mentioned came across quite a number of farmers with crops and in every case on summerfallow. One case was most striking. A farmer near a certain small town had a crop of 22 bushels per acre, while not a nearby neighbor harvested a bushel. He was the only man who had summerfallowed any land in 1913 and the 1913 summerfallow was his 22 bushels per acre field in 1914.

Moral—Don't neglect to do some summerfallowing each year.

## MONEY TO LOAN

### Improved Farm Property

AT LOWEST CURRENT RATES. NO DELAYS. APPLY TO

The Great-West Life Assurance Co.

WINNIPEG MANITOBA

## Peerless Poultry Fencing

A real fence, not netting. Strongly made and closely spaced, a complete barrier against animals of any kind. Keeps the small chicks confined. They can't get through. Does all and more than is required of a poultry fence.

The heavy, hard steel top and bottom wires with intermediate laterals will hold a carelessly backed wagon or unruly animal and immediately spring back into shape.

The wires are held together at each intersection by the Peerless Lock.

Send for Catalogue and address of nearest agent. We make a complete line of farm and ornamental fencing. We now have agents nearly everywhere, but will appoint others in all unassigned territory. Write for catalogue today.

THE BANWELL-HOXIE WIRE FENCE CO., LTD.  
WINNIPEG, MAN.  
HAMILTON, ONT.

## A Few Pointers on Tractor Design

(By One Who Has Suffered)  
H. BUCKNER HIGGINS

Far it be from me to pose as a gas engine expert, or consulting engineer or anything of the sort, but I have spent several years working with internal combustion motors of various kinds from seven cylinder rotating monstrosities for aeroplanes to four cylinder 60-horse power tractors. I have designed, built, operated, repaired and fervently cursed several different types, and have, as a matter of course, accumulated several ideas about their designs, construction and general get up, a few of which I append herewith.

In my humble opinion, the first, foremost and primary object to be borne in mind when designing a tractor is accessibility. Many designers disagree with me in this, as any operator or repair man knows, but I believe that I could convince them if I could put them through some of my experience.

Take, for instance, crankshaft bearings. The engines with which I am most familiar are of the four cylinder, vertical type, and admittedly among the best on the market. Yet observe all the trouble necessary for the simple operation of taking up crankpin bearings, about the most frequent job on the motor. First, one has to crawl under the machine on his knees (generally in a cactus patch at that) and drain out three or four gallons of oil. Then take the oil pans off, crawl out again, turn the motor over where you want it, crawl underneath, remember that you left your pliers on the platform, crawl out and get them, also get a socket wrench, monkey wrench, some rags or waste (if you're lucky, otherwise you wipe your mitts on your overalls) crawl underneath again, wrestle a while with four

kinked up cotter pins and lose three of them, loosen four nuts that were tightened by a giant of some sort, pull the bearing cap off and, in so doing, spread the shims over the surrounding landscape, gather up said shims and try to wipe the sand off them with a still dirtier gunny sack—same dose for the bearing cap sort shims out and take out one, put the rest in place and the cap back and screw up the nuts as tight as you can. Then you discover that the slot in the nut is just past the hole in the bolt, and you have to turn it around to the next one. This you finally accomplish, after the atmosphere in your vicinity has acquired a rich, sulphurous odor. You then crawl out and rustle up some baling wire to replace the lost cotter pins and crawl back again and attempt to tie it tightly in place, in which you seldom succeed. Of course, the hot oil and water from the engine dripping down your neck makes things go a little smoother, but these are largely counteracted by a raw wind which is whistling around.

You then throw all the tools outside and crawl outside yourself with a sigh of relief. If you took out a thin shim, you then discover that the bearing is still loose, if a thick one, she's so tight you can't crank her.

If she's too tight, there's only one thing to do—do it over again—however, if she's just a little loose you say: "Aw, h—. She'll run till another one gets loose and then I'll take them both up." Then you get down and put the oil pans on, trying not to leave out any more of the gasket than you can help, pour in the oil, put back the side plates and get ready to go.



Officer, to new recruit, wishing to identify his regiment: "Who are you?"  
Private Macdonald: "Fine, thank ye, an' hoo's yersel'?"

MENTION THIS PAPER

## A. STANLEY JONES, North Battleford SASK.

### THE ORIGINAL SMALL THRESHING MACHINE

- 28-in. Separator, alone, with all fittings, as shown, freight paid Manitoba and Saskatchewan. CASH \$317.00
- 24-in. Separator, alone, with all fittings, as shown, freight paid Manitoba and Saskatchewan. CASH \$284.00
- Complete Outfit, consisting of 8 h.p. Engine and 28-in. Separator, with all fittings, including main belt and truck, with 16-ft. reach, delivered anywhere in Manitoba or Saskatchewan, carriage prepaid, for CASH \$670.50

Write for Time Terms and Fully Illustrated Catalog

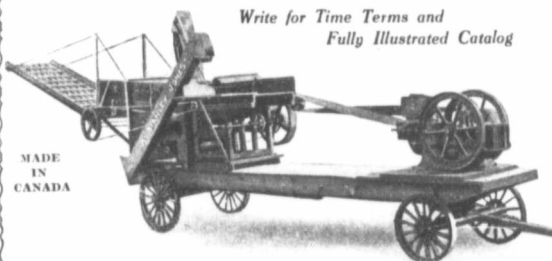

MADE IN CANADA

AS SOLD TO

- NORMAN M. ROSS, Esq., Government Experimental Farms, Indian Head.
- PAUL GERLACH, Esq., Dundurn, Sask., winner of the World's prize, 1913.
- JOHN ILLINGWORTH, Esq., Rosetiff, Sask., who came within three-quarters of a point of Mr. Seager Wheeler of the World's prize in 1914.

- W. S. SIMPSON, Esq., Pambrun, Sask., winner of World's prizes for Flax; winner of 1st and Diploma, Spokane; 1st Provincial Fair, Regina; 1st Swift Current; 1st Dry Farming Class, Denver, U.S.A.; 2nd Open to Irrigated and Non-Irrigated Farms, Denver, Colorado; 3rd Provincial Seed Fair, Saskatoon. Just as it came from A. Stanley Jones Small Thresher.

AND HUNDREDS MORE. SEE CATALOG

Write for fully illustrated catalog with details and also a copy of the report of the Government Expert, as published in the tenth report of the Department of Agriculture, telling you about these machines.

## Steam or Gas Tractors

Equipped with

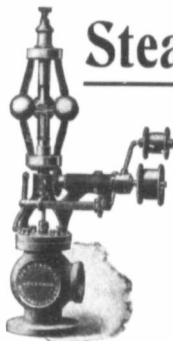

### PICKERING "THE GOVERNOR WITHOUT JOINTS"

give greatest efficiency

FITTED TO EVERY BUILD OF ENGINE

Patent Ball Ranger Speed Changer Supplied on all Genuine Pickering Governors.

Will increase speed 50% or more.



### THE PICKERING GOVERNOR CO.

PORTLAND

CONN, U.S.A.



### BEST ANTI-FRICTION BABBITTS ON THE MARKET

With forty years experience in manufacturing alloys for all classes of machinery, the HOYT METAL CO. has evolved two alloys which are unsurpassed by anything of the kind now in use.

HOYT'S NICKEL GENUINE Babbitt is especially designed for heavy duty gas tractors.

HOYT'S FROST KING Babbitt is especially designed for threshers, separators and stationary engines of all classes.

If your dealer does not carry these metals in stock, send your order direct to us. In order to insure prompt delivery, send postal money order.

Nickel Genuine 28 lbs. box 75c per lb. 30 lb. box 70c per lb. 60 lb. box 65c per lb.

Frost King 40c per lb. 35c per lb. 30c per lb.

Delivered to your nearest express or post office station.

### Hoyt Metal Co.

Eastern Ave. and Lewis St. TORONTO

FACTORIES—London, Eng.; Toronto, New York and St. Louis.

Y  
sadd  
An  
gods  
have  
First  
small  
about  
ers a  
which  
a ton  
cast i  
with  
some  
ing a  
or pre  
do in a  
And  
the g  
aren't  
them.  
The b  
seldom  
that w  
crank-c  
them,  
limited  
the nut  
Ther  
the shi  
and tal  
and tig  
and pu  
while e  
times t  
her tail,  
item of  
cast iron  
same tin  
nuts tha

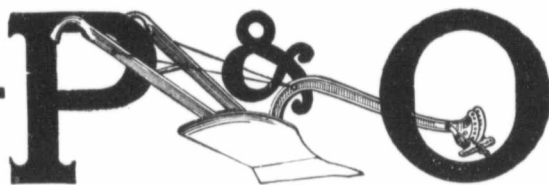

## Why Experienced Plowmen Prefer the Little Genius

**Power Lift  
On All Three  
Wheels**

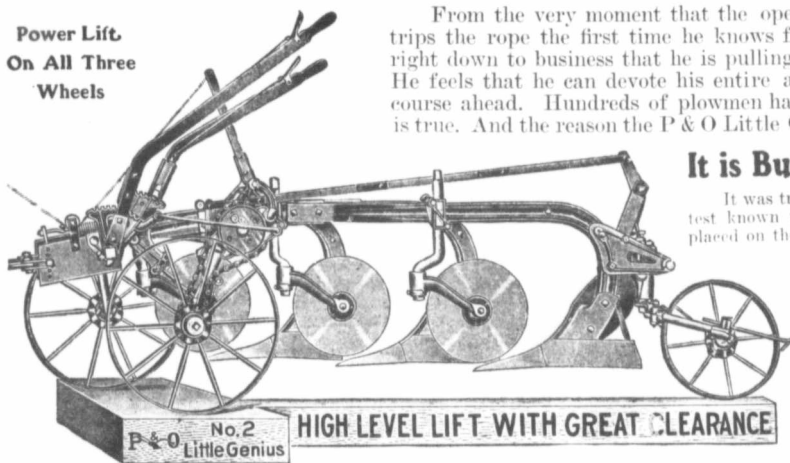

**HIGH LEVEL LIFT WITH GREAT CLEARANCE**

Made By PARLIN & ORENDORFF CO., Canton, Il, U.S.A.

From the very moment that the operator of the P & O Little Genius trips the rope the first time he knows from the manner in which it gets right down to business that he is pulling a plow that he can depend upon. He feels that he can devote his entire attention to his engine and the course ahead. Hundreds of plowmen have testified, voluntarily, that this is true. And the reason the P & O Little Genius makes good is that

### It is Built for the Field Test.

It was tried out repeatedly—submitted to every test known to experienced experts—before it was placed on the market. It was designed not only to do 100% efficient work, but to do it with a minimum of attention on the part of the operator. Bright paint and smooth sales arguments never kept a plow out of the fence corner. It is the ability to stand up, day in and day out, to hard work under varying conditions, that makes the P & O Little Genius popular with plowmen. Write now for circular and testimonials.

**International Harvester Company of Canada, Limited,** Sales Agents For Canada  
WINNIPEG ESTEVAN BRANDON CALGARY REGINA SASKATOON EDMONTON YORKTON LETHBRIDGE NORTH BATTLEFORD

Yes, it's a sad tale, mates, but saddest of all, it's largely true.

And the main bearings — Ye gods! Thank heaven you don't have to take them up very often. First you have to take off the small oil pans and then remove about forty-seven nuts and washers and then the main oil pan, which you swear weighs at least a ton. Of course it has to be of cast iron, one-half inch thick, to withstand the terrific strain of some 4 or 5 gallons of oil splashing around inside it. Aluminum or pressed steel would never, never do in a place like this.

And those bearings. As a rule the gear-end and center ones aren't so bad, as you can get at them, but, oh, you flywheel end! The bolts will turn and it's very seldom that you have a wrench that will go down between the crank-case and flywheel and hold them, to say nothing of the very limited turning are available on the nuts.

Then, after you have taken out the shims and put the caps back and taken a four handed wrench and tightened up those big nuts and put the pins in, and meanwhile crawled in and out a dozen times to see if you can still twist her tail, then comes the nice little item of trying to hold that awful cast iron pan in place and at the same time screw up a couple of nuts that don't want to start. By

the time everything is finished and ready to run you know that you have done something, even if you haven't accomplished a great deal.

Now, this tale of woe would be worse than useless if the above conditions could not be improved without sacrificing strength, durability or any other good quality; but somehow I can't persuade myself that such is the case.

To return to crankshaft bearings; in the first place, they could and should be larger, so as not to require such frequent adjustment.

There are plenty of other heavy-duty motors, both marine and stationary, that work under rather trying conditions, but you don't hear of them taking several hours a week to keep their crankpin bearings in shape.

Even frequent adjustments would be much more bearable if one could simply remove a side plate, reach in with an S wrench and do the job without so much preliminary work. In many of the best marine motors the crank-cases are built up of A frames, to which are clamped light sheet metal covers. These covers are oil tight, but easily removable, and when taken off leave ample room to use a wrench on every nut in the motor. This type of crankcase, when properly braced, has proved to be fully as rigid as the box type; although I suppose

it is slightly more expensive to build.

But give a motor this kind of a foundation and design the rest of it in accordance, so that a man doesn't have to remove half the accessories to get at the valves, as on some I have seen, or other like stunts, and it is my humble belief that it would be hard indeed to persuade a man who owned one to have anything else.

I know from experience that this sort of thing makes the poor devil at the drafting table smoke more cigarettes than are good for him, and maybe lose a little sleep if he takes his job seriously, but he only has to wrestle with it once, whereas the man in the field has the same engines for a steady diet during several seasons.

However, I realize that this is a somewhat radical thing to ask for all at once, but there are several minor details that could be mightily improved without great expense.

Take that little matter of cover plates, oil pans, etc., which have been the cause of many unseemly words and mashed fingers. I can see no reason whatever why these should be so heavy. If a piston and rod get loose they will make about as big a hole in a thick place as a thin one, and so far as I can see there are no other excessive strains on them.

While the dies for stamping

these out of steel would be somewhat expensive, still the lower cost of production in fair sized quantities should more than offset this in the end, and to an experienced man the light weight of these parts would be a strong talking point. Or, if the output is rather small, they could be cast of aluminum in much thinner sections than are now used.

Now consider the connecting rods. If the lower ends were of the hinge type, with the bolts toward the open side of the crank-case and slotted shims used, adjustment would be a matter of a few minutes only.

Before I close, I would call attention to another phase of the accessibility argument. It would add much to the life of the motor in most cases. If a job involves considerable work, especially of such a grimy variety, the average man won't do it any oftener than he thinks he positively has to. As a result, many engines are running with loose connecting rods, which would be kept in much better shape if a few minutes would do it, and other things being equal the bearing would last much longer in the latter case.

There are several other points which I would like to discuss if, perchance this should slip past the editor. In the meantime let's all boost for "accessibility," first, last and all the time.

## The Carburetor and Fuel Problem

**A** YEAR ago the carburetor problem was comparatively simple. Gasoline was cheap and plentiful even if the grade was lower than seven or eight years ago. There did not seem any immediate prospect of either scarcity or of higher prices and the carburetor of kerosene or heavier oils received little or no attention except from research workers. Now conditions are reversed. Gasoline has risen in price and is still rising. Again, there is need of a good kerosene carburetor and, in fact, such a carburetor must soon be forthcoming if the gas engine business is to continue at its present volume. That suitable low grade gasoline or kerosene carburetors are not only possible but that they will soon appear is the general belief of those in a position to know. Let us look into some of the requirements and possibilities of such carburetors.

To anyone who has followed the descriptions of the various carburetors described during the past few months it must seem that there are endless varieties, and this would seem to indicate that there is a general lack of appreciation of the fundamental principles of carburetion. One can not help but feel that this is true to a considerable extent, otherwise there would be greater uniformity. Another thing that has hindered development has been the changing from time to time of gasoline grades. No sooner is a carburetor developed that will handle a certain grade satisfactorily than another and lower grade makes its appearance.

Lastly, the new processes of making gasoline have made their appearance though as yet the Rittman process has not come into extended use. No one appears to know what the future fuel will be, whether it will be all a low grade gasoline, partly gasoline and partly kerosene or something different. It would seem that if a true gasoline can be made and that practically all the crude can be so transformed, the product of the refineries will be enough kerosene to supply the demand for illuminating purposes while the remainder will all be transformed into gasoline. Obviously that is what will eventually happen when the refiners have had time enough to adapt themselves to the changed conditions. When that time arrives there probably will not be a very wide spread in price between kerosene and gasoline, and gasoline may very likely be sold at a lower price than it is quoted now.

The great trouble is we are living in uncertainty. No one knows just what will happen next. It is this uncertainty perhaps as much as lack of knowledge that has retarded carburetor development along right lines.

Just at present there is a demand for a truly efficient kerosene carburetor but if kerosene should be manufactured in smaller quantities on account of the development of gasoline methods of production they would not be of value for very long.

The efforts that have been made to use kerosene have always appeared very crude and very faulty. Carburetors similar to those used for gasoline have always been employed, great changes of fuel pass into the cylinders and then when the motor gets too hot, water is thrown in to cool it down. The use of water is in itself an acknowledgment that the carburetor does not do its work and that the fuel is not in condition to burn; for the water serves no particularly useful purpose in itself. It is not a fuel and it does not make fuel burn any better. All it does is to absorb heat and carry it away. Now it is heat that makes any engine run and here we have a condition where the engine is unable to utilize all of the heat and so it is wasted. And yet pound for pound, kerosene does not contain appreciably more heat than gasoline. Also, and this is significant, in engines of high compression type water does not have to be used. We are thus led to the inevitable conclusion that the carburetion is faulty and it is. The fact of the matter is kerosene is hardly carburetted at all. It is merely broken up into a number of pieces and dumped into the cylinder where it burns slowly and partially and leaves a nasty sooty mess. If the right quantity were fed into the cylinder, and it were in a condition to burn completely there would not be too much heat and the engine would run cool. The whole trouble is that the carburetors do not carburet. We know kerosene will burn and burn completely when conditions are right; for example a kerosene lamp performs all right, then why not an engine?

The whole trouble is that kerosene does not vaporize readily, and it does not pulverize as easily as gasoline. It requires heat to vaporize any liquid and some requires more heat than others. High test gasoline requires very little and ether still less. Kerosene, on the other hand, requires a great deal.

**KILL-EM-QUICK—The Time-Tried Gopher Poison**



## Still Raising Gophers?

Every farmer who lets gophers live is robbing himself. Are you still raising 'em? Why don't you kill 'em? It's easy! Safe! Quick! Use

### Kill-Em-Quick Gopher Poison

Kills 'em all at one time. Its odor attracts gophers, they hunt for it. **It's instant death!** Easy to use; simply stir into moistened cuts or ground feed. **Safe**, no danger in preparing, spreads no weed seed. **Guaranteed** to kill 'em all for 1 cent an acre or less. **Money back** if it fails. Guaranty printed on every package. 3 sizes, 50c, 75c, \$1.25; enough for 40, 80 and 160 acres.

Get genuine Kill-Em-Quick, the time-tested gopher poison from your druggist. If he can't supply you we send direct upon receipt of price. Don't let gophers ruin your crop again. Send for FREE Gopher Book.

### Kill-Em-Quick Co., Ltd.

Successors to Mickelson-Shapiro Co.

Dept. C

Winnipeg, Canada

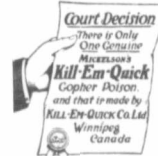

# SOW FLAX

## This Spring!

In a recent article advising Western Farmers to grow flax, J. H. Griddale, B. Agr., Director Dominion Experimental Farm, says:

"Where wheat seeding has progressed rather slowly, it will often be advisable to sow the last few acres intended for wheat to flax instead. . . . For the new settler or the man with new breaking done before May 25 or 26 flax offers an opportunity for money-making this year such as is not possible with any other crop."

The average yield of flaxseed in Western Canada exceeds 12 bushels per acre. The average price for months past has been around \$2 per bushel. Figure it out for yourself!

Flax does best when sown late in May, and well even when put in during the first week in June. This gives a chance, after it is too late to sow more wheat, to break new land, put any low, wet spots into good condition, and get a considerable extra acreage into flax.

On new breaking the flax roots rot the old sod, loosen up the soil, and leave it in splendid condition for wheat. Flax has the good effect of summer-fallowing, and at the same time produces a profitable crop—which no other grain will do.

Get every extra acre you possibly can into shape and SOW FLAX—

# IT PAYS!

Ga  
enoug  
any t  
comp  
ther,  
will i  
gets  
vapor  
sene  
Even  
some  
walls  
which  
vapori  
ly. O  
to do  
ough  
around  
heat m  
the su  
through  
made t  
gas reac  
The  
that the  
motor v  
ly woul  
tent bec  
kerosene  
be a c  
heat wi  
ature an  
not qua  
gas to e  
tric effi  
much ex  
pose.  
volume c  
be heate  
Fahrenh



# Every Foot Spells "Quality"

The greatest threshing successes of 1915 were made by outfits run with our *quality* belting—the "LION" (rubber) brand and the "YELLOW FELLOW" Endless Thresher Belt. They are still proving their absolute reliability in disposing of the big acreage that lay in the stook throughout the winter. It is not possible to procure at any price belting equipment that will give better results in any endurance test or such immunity from slippage.

GET EITHER THE



## LION BRAND

RUBBER BELT

OR THE

## Yellow Fellow

ENDLESS THRESHER BELT



You can get them from any thresher company doing business in Canada. They cost a little more than other fabrics that are a big risk from the day they are used in any power transmission, but we guarantee our goods against all disappointments from slippage or breaking. They are the "guards" that will never betray their trust under any pressure—at threshing or at any time.

### Gutta Percha and Rubber Limited, NOT IN ANY TRUST OR COMBINE

Winnipeg, Fort William, Regina, Saskatoon and Calgary

Gasoline and ether can absorb enough heat from air at almost any temperature to vaporize, not completely, it is true, in cold weather, but enough so that part of it will ignite and after the engine gets hot the remainder will be vaporized in the cylinder. Kerosene is much more refractory. Even if a portion does vaporize some of it will condense on the walls of the manifold. And that which goes into the cylinder vaporizes slowly and burns slowly. Obviously the necessary thing to do is to pulverize it very thoroughly so that heat can get around every particle. Then the heat must be supplied not only to the surface of the mass but all through, and provision must be made to prevent cooling until the gas reaches the cylinder.

The objection might be raised that the volumetric efficiency of the motor would suffer and it probably would, but to only a slight extent because the latent heat of kerosene is high and there would be a considerable absorption of heat without any rise in temperature and it is rise in temperature, not quantity of heat, that causes gas to expand and reduce volumetric efficiency. But there isn't as much expansion as one might suppose. For example, if a given volume of air, say a cylinder full, be heated from seventy degrees Fahrenheit to one hundred and

seventy, its expansion at the same pressure will only amount to a little over eighteen per cent. If now this air is called upon to yield up its heat in evaporating gasoline or kerosene its temperature will be reduced because the latent heat of these fuels is relatively high, being about one hundred thermal units per pound.

Air, on the other hand, has a low specific heat so that a pound of air even at high temperature contains relatively a small quantity of heat. When the fuel is evaporated this heat is absorbed by the fuel and the temperature of the mass is lowered. Thus it will be seen that even though the mass of air is heated through a considerable range it will be cooled when it gives up its heat to transform the liquid fuel into a gas. This then compensates to a great extent for the loss of volumetric efficiency. Even though there were a loss as high as ten per cent it would be a small price to pay for the ability to use kerosene in your motor.

The ten per cent would be merely a reduction of power below the maximum output of the motor. It would not be a loss in motor efficiency but merely a lack in power.

Of one thing we can rest reasonably certain and that is if it is necessary to equip engines to burn kerosene, or benzol or alcohol a

way will be found to accomplish the task. The time may even come when coal will be transformed into gas and this gas be compressed at high pressure and carried in tanks and supplied to the motors as needed. In fact, experiments have been carried out along these lines that gave promise of ultimate success. There is no reason why anyone should feel alarmed at the fuel situation. This generation of men will never see the time when it will not be possible to obtain motor fuels at prices that are not prohibitive.

## Heaves CURED

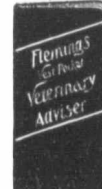

—by removing the cause—and cured to stay cured—if boxes of Fleming's Tonic Heave Remedy fail to effect a cure of any case, old or new, we will refund the full amount paid.  
Per Box, \$1.50; 3 for \$2.50.  
Mailed on receipt of Price.

Scratches Disappeared  
Gentlemen—I gave a course of your Tonic Powders, which has put a horse and his mate in fine shape, and a touch of scratches has quite disappeared.  
Geo. A. Miles, Orville, Ala.

Full information to Fleming's Vest Pocket Veterinary Adviser

Write us for a Free Copy  
**FLEMING BROS., Chemists**  
63 Church St. - Toronto, Ont.

## MASTER MECHANIC

UNION MADE

## OVERALLS

*Cut Full and Roomy*

MADE IN WINNIPEG BY  
**WESTERN KING MANUFACTURING COMPANY LIMITED**

AS I sit in front of my desk on this winter eve with the mercury fooling around down in the basement of the thermometer the idea of preparing for spring work sounds like a joke, but the good brother who fools around out in the machine shed with a wrench and hammer these winter days, tightening up loose nuts, cleaning out oil holes, looking things over with a view to ascertaining where new parts are needed, and in general getting things in readiness for the spring campaign, will find himself right up in the front row when the noses are counted: the while his more indolent neighbor who has neglected to attend to these things will be doddering along and complaining that "everything seems to bother this spring."

As an aid to preparedness, there is nothing that will help more than a good work shop and a liberal assortment of tools. The writer has what is probably one of the most complete outfits of tools to be found on any farm in his state, and notwithstanding the rather stiff price paid for them, they are one of the best investments he ever made. The cost was not noticed so much as they were bought a few at a time as the need for them was felt, the first ones being purchased nearly twenty years ago. A good many farmers say they can do nothing with tools, but that is "all bosh." Any one with ordinary intelligence ought to be able to make a boat for a wagon tongue, put in a new single-tree, fit a tongue to the hay-rake or sharpen a set of harrow teeth. Not one of these jobs requires costly tools or any skill to speak of and the ability to make all such simple repairs will save one much money in the course of a year. One can now buy wood stock, such as single- and double-trees, tongues, wagon bolsters, in fact, anything a farmer will ever need in that line all dressed ready to bore the holes and put in the bolts. Putting in a new wagon bolster is simply a matter of boring a few holes and bolting it fast. One can use the malleable stakes and it makes a good, solid job.

One would not expect a farmer to undertake to rebore a cylinder for a gas engine or make an arbor

## Preparedness on the Farm

By R. RINKER

for a circular saw. Such a job requires very expensive tools and the man who possesses the skill for that kind of work is not commonly found working on the farm. The tools that a farmer can and should own can be bought for less than a hundred dollars. It would be the sheerest folly to buy the fancy ones. Good, plain, honest ones that are made for hard, everyday work are the ones to buy and it is not necessary to have a great variety although one must take care to have the sizes that he will most need, in taps and dies; the sizes from one-fourth to three-fourths will meet the requirements of all farmers who own only the ordinary farm machines. Perhaps one of the most annoying things that happens most frequently on the farm is the breakage of a bolt; having the taps and dies, one can drive in to the shop, cut off a rod of suitable size, cut threads on each end, screw on nuts and be back in the field in a few minutes. It would be impossible to carry on hand all sizes of bolts, but as has been shown one can have all sizes at a moment's notice. If one has fairly tough iron or steel, an eye bolt can be made just as easily, but it would be better, of course, to bend the eye with the iron hot. The actual cash outlay for simple repairs like the above is little, but if one is far from town the time saved will soon buy a set of taps and dies and several other tools. To go along with the tap and die

set one will need several sizes of drills. The sizes must be about right or the taps will be likely to break, a tap not being a very husky tool at best. Perhaps ninety per cent of the holes a farmer will have to drill will be less than half an inch in size and, as the whole set from one-sixteenth to half an inch can be bought for less than four dollars, it is best to buy them all. Since the sizes advance by sixty-fourths of an inch it will be easy to select just the right size for the tap one wants to use.

To illustrate what may be done in the farm shop, the writer will set down a few of his own experiences; just a few days ago while hauling manure, the feed chain parted as a result of a stretched link, wrapping around the feed sprocket. It soon formed a coil big enough to force the apron up against the cylinder and two of the three cylinder heads broke as a consequence. But was it necessary to go to town and order new parts, and wait several weeks for them to come? Not at all. The spreader was hauled up close to the shop door, a fire was kindled in the forge and some angles were made out of an old tire, holes drilled in the angle pieces and in the web of the old heads, the parts riveted solidly together, the bars bolted back in place and the whole thing was done at an expense of a few cents for iron and rivets and half a day's work. One of my neighbors had a similar accident at about the same time but it cost

him just ten dollars plus the time lost in bringing it to the writer's shop.

While threshing last summer, a knife bar in the feeder broke. We drove to the shop, selected some strap iron of suitable size, drilled holes and riveted the parts to the bar and lost not over an hour and a half of time. I charged the thresher fifty cents for the work, he saved several dollars and we saved enough ourselves to make it well worth while to have the tools. Threshers all say this is a good place to have a breakdown, but few of them are lucky enough to be here when breakdowns occur.

Another neighbor had an old disc that was in good order except that the cast iron bearings were worn out and he could not get new ones. He brought it to the writer and an examination revealed the fact that wood bearings could be made and fitted without much trouble. Thus the disc was given a new lease of life and the owner expressed himself as being highly pleased with the job.

Another job that saved me some money was the fitting of a grate in the kitchen stove. There has been kicking around the place for a number of years an old stove grate that was in excellent condition. A comparison of it with the burnt out grate showed that fitting it would be a comparatively easy matter, all that was necessary being the grinding off of the shanks at the end about an eighth of an inch. It will be seen from these illustrations that one can save money in dozens of ways; one thing suggests another. This is, I think, about the first time that a grate out of one make out of one stove has been fitted to a stove of a totally different make. Hereafter, the writer intends to throw nothing away.

A few years ago a corn sheller was brought in that at first sight looked hopeless. The main gear was broken in a number of places and both level runners were broken in the web. The gear was mended by cutting out thin plates and riveting them to the spokes and the rim, there being enough of a web to make this possible. The level runners  
Continued on page 32



"Some" Onion Crop—From the Sunny Slope of an Alberta Farm.  
(Courtesy of the G. T. P. Ry. Co.)

### WHEN IS A GOOD OIL NOT GOOD?

**WHEN** it's used in the wrong place. You cannot expect a heavy oil designed for use on a low-speed, high-power tractor to lubricate efficiently the finely adapted bearings of a high-speed, low-power tractor.

For every part of every machine there is one right oil—and it's worth money to you to find it.

The Imperial Oil Company makes a large number of farm lubricants—each one exactly suited for its particular purpose.

#### STANDARD GAS ENGINE OIL

Recommended by leading builders for all types of internal combustion engines, whether tractor or stationary, gasoline or kerosene. It keeps its body at high temperature, is practically free from carbon, and is absolutely uniform in quality.

#### PRAIRIE HARVESTER OIL

An excellent all-round lubricant for exposed bearings of harvesters and other farm machinery. Stays on the bearings; will not gum or corrode.

#### CAPITOL CYLINDER OIL

The most effective and economical lubricant for steam engine cylinders; proven superior in practical competition with other cylinder oils.

#### ELDORADO CASTOR OIL

A high-grade, thick-bodied oil for lubricating the loose bearings of farm machinery, sawmills and factory shafting.

#### THRESHER HARD OIL

Keeps the cool bearing *cool*. Does not depend on heat or friction to cause it to lubricate.

**STEEL BARRELS**—All our oils can be obtained in 28-gallon and 45-gallon steel barrels. These barrels save their cost by eliminating leakage. You use every drop you pay for. Clean and convenient.

If your lubricating problem gives you trouble, let us help you. Tell us the machine, the make, the part—and we will gladly give you the benefit of our experience in selecting the proper lubricant.

#### THE IMPERIAL OIL COMPANY

Limited

BRANCHES IN ALL CITIES

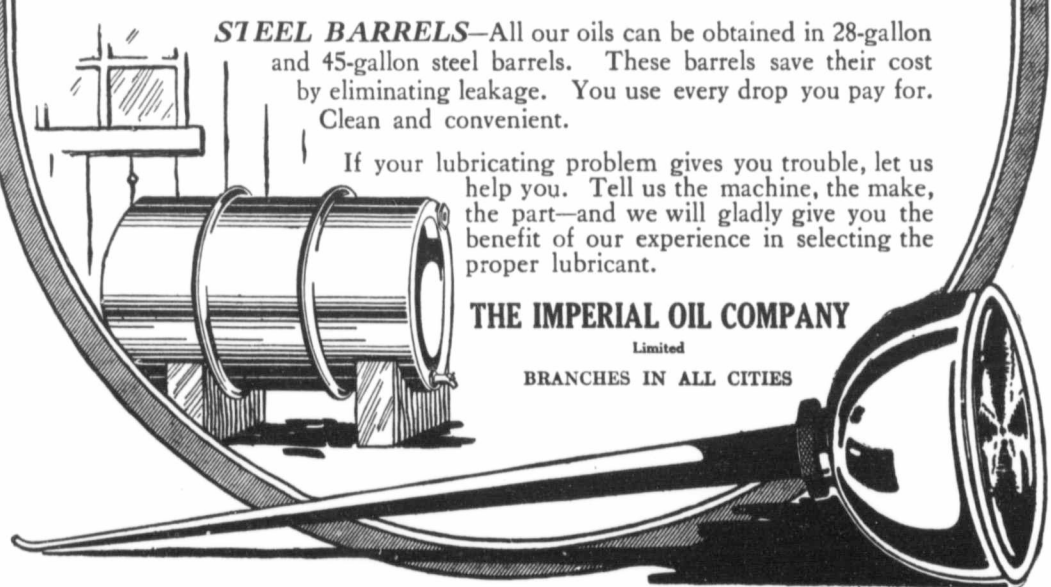

LAST season you will remember the weather man did not seem disposed to give the farmer a chance to beat him. The great war was to blame, so every one said, and it looks as if the same excuse might obtain this year. We ought to be prepared.

How many horses have you fed during the winter? Have you figured up the bill? How many hours per day have you used these horses during the winter? All perfectly good questions for the business farmer. This is the time to answer them. You are probably thinking that it is about time to get the horses in off the stock field and give them just a little better care before the spring work starts. If they don't get fat now, ten chances to one they won't have a chance to again this year. Most of us have pride enough to want to begin the spring work right. Pulling a plow, a disk or a drill is no snap under the most favorable conditions.

Weather is just one of the things over which we have no control and is up to us to get the crop in between showers. We might have one of those dry springs when it is almost impossible to pull the plow through the dry hard soil. At best the time for spring work is short and it is always difficult to get the crop in even under the best conditions. May be Dick or Jock will get the distemper or Maud may be going to have a cold. Then we are short of power. What is there to be done about it? Buy more horses which according to the U. S. Department of Agriculture, cost eighty dollars per year to maintain on the average farm? The chances are that you will find some way to get along with what you have, thinking that, by the time the summer work is on, all the horses will be ready for work, but summer's work soon turns into fall work and before you know it your horses are skinny and run down. Well, power is the problem, how can it be solved?

Keeping a set of farm accounts has been a mighty fine thing for the man who wants to use these figures to show that farming is a business, that it must be conducted on a business basis, not by

## Farming—a Power Problem

By FRANK M. WHITE

"guess and by gosh." The difference between what it costs to do a job and what you get for the work done represents either a profit or a loss. How can the same acreage be made to show greater net returns is the question in a nutshell. If there is a leak, where is it?

Scarcity and high cost of farm labor demand a study of our farm factory management. In a bulletin, No. 125, published by the University of Missouri, some very good figures have been worked out on the cost of manufacturing farm products. In order that the manufacturer may make money and beat the other fellow he must beat him on the cost of production as well as on the quality of the product. Man and horse labor play a very important part in the cost of production, so much so that some means of cutting down on these two items is very important. It is rather difficult to compare the hours required for a horse to put in on producing an acre of corn with that of mechanical power, for the horse is not a mechanical unit and we can not definitely say how many heat units of fuel he requires or the repair charges or the amount of depreciation. However, it is safe to make the statement that if one man can handle more power and do his work effectively as before, the power hours of field work can be reduced considerably. A study of man and horse required may help to solve the problem.

The data given in bulletin No. 125 shows that the horse is not a very busy machine, only working on an average of 3.57 hours per day throughout the year. January, February and March are very light months and he is only called upon to work 1.8 hours; while during May, June and July there are only 5.2 hours work per day to be done. The average cost per hour is 7.19 cents. Even for the days of the year when you would

expect the horse to be busy there isn't an awful lot of time required. Now, if the horse is in poor condition working these few hours, what would he be if you worked him on an average of ten hours per day? The horse as a machine is expensive.

By investigating some of the items of our factory cost, it may be that some of the operations may be reduced in number of power hours required. A study of the horse hours required per acre for disking, plowing, harrowing, planting corn, cultivating corn, in fact, all field operations indicates that 26.9 per cent of the total cost of producing corn is charged to horse labor; 18.8 per cent of the cost of producing wheat is horse labor; 12.3 per cent of the cost of producing oats, 13.5 per cent of the cost of growing clover, and 18.8 per cent of the cost of raising cow peas is for horse labor. This item for horse labor is more than any other item in all cases except for clover. For this crop man labor is greater. The average cost of man and horse for growing corn, oats, clover, cow peas, soy beans, is twenty-six per cent and eighteen per cent respectively. The cost of seed, rental of ground, and taxes certainly cannot be reduced. If anything, they will increase in the future so that labor is the only item that can be cut. The farm tractor seems to offer the solution of the problem, for one man can handle larger units of power just as easily and work ten or more hours per day if necessary.

I do not believe that the manufacturer is trying to sell something worthless and attempting to talk the farmer into buying an article that he doesn't want, as was the case with old time lightning rod agents. We have found out that it is impossible to get along without more power. The windmill is disappearing and the small gas engine has taken its

place. We have been educated to the fact that it is cheaper to let the gas engine work while we rest or go about the chores. So the tractor has come in to let the horse rest during the hot weather, not necessarily as a substitute but as a supplement to the horse. Now the practical man realizes the need of this tireless power, not alone to take care of what is so often spoken of as the peak load but to take care of work as an everyday farm work horse.

What is a practical farm tractor? The question can best be answered by naming some of the jobs that a horse is expected to do. The horse is a very flexible machine and can do field work requiring a great deal of power and will travel at the rate of one and one-half to two miles per hour, or for road hauling maintain a speed of two to three miles per hour, or for light road work maintain a speed of four to five miles per hour. He plows corn, drills small grain, plants corn, draws the smoothing harrow, hauls manure, and pulls the harvester. These jobs all require small units of power, and most all farm operations requiring power demand small units. Some of the other jobs which a horse cannot do are sawing wood, filling silos, baling hay, shelling corn, running the threshing machine, and these also require a small amount of power. So it seems to me that the tractor must be designed as a small power machine, a machine which will under any circumstances pull at least two plows, three or possibly four under good plowing conditions. It should also be light enough to get around and do the light hauling, disking, drilling, etc., which a horse does effectively. You must be able to use it effectively to deliver belt power. There are tractors so poorly designed for belt work that you would never try them but once.

A tractor to be an all around horse must be nimble and must be one that the farmer would rather use than go out to the barn and harness a team. When the tractor is preferred over the horse then we can say that the tractor is truly a universal farm power. It

Continued on page 47



Saving Thousands of Dollars in draft-horse flesh

# For Nearly 3/4 of a Century DOMINANT PROGRESS

*Has made the Red River Special the Threshing Machine of the age*

Since 1848 the Nichols & Shepard Company has been interested in one line of endeavor only—the making of machinery for threshing grain. They started their career with a revolutionary improvement in the threshing process that put them in the lead—continued inventiveness of the same bold character has kept them at the front.

## What has been accomplished?

*By beating out the grain*, a principle that has never been abandoned since originated by this Company, and applied to their famous vibrator Threshing Machine, more separation, better separation, faster separation, cheaper separation, are all combined in one machine. Owning or using a *Red River Special* rig, you can do more than you can do with any other known make of threshing machine, and it is so written as a part of your purchasing contract.

*What do you expect to get when you select another kind?*

## The Red River Special

*It Saves the Farmers' Thresh Bill*

You ought to read your own neighbor's opinion of a good job of threshing. You'll find it in the Home Edition of the Red River Special paper. Write for a copy and post up. The Big Catalog will be sent also if you ask for it.

**NICHOLS & SHEPARD CO.**

*(In Continuous Business Since 1848)*

Builders Exclusively of

**THRESHING MACHINERY**

Red River Special Threshers, Feeders, Wind Stackers, Steam and Oil-Gas Traction Engines

**BATTLE CREEK, MICH.**

BRANCH HOUSES (With Full Stock of Repairs) At

WINNIPEG, MANITOBA

REGINA, SASKATCHEWAN

H. P. NORTON COMPANY, CALGARY, ALBERTA

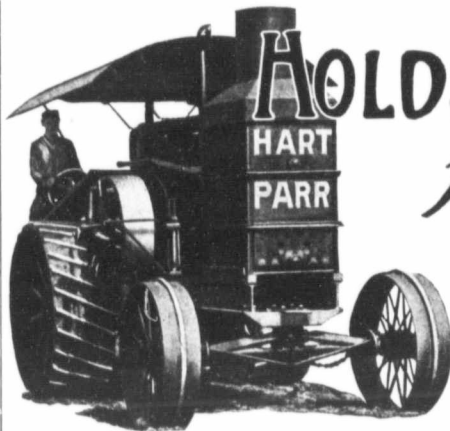

# Holds World's Record for ENDURANCE

OVER 90 PER CENT OF  
THE FIRST YEARS OUTPUT  
MARKETED 14 YEARS AGO  
STILL IN SUCCESSFUL  
OPERATION TODAY

## That Scale Shows Two Methods of Solving The Farm Labor Problem

50c  
48c  
45c

Gasoline is going up. Therefore, gasoline power is out of the question. Kerosene is cheap. Hart-Parr Tractors have always burned kerosene. Get just as much power on it. Use no more gallons of it. One man operates a Hart-Parr Tractor—and with Old Reliable you do the work of many teams and many hired hands in a fraction of the time and at a minimum of the expense.

### Overcoming Great Shortage of Labor

Canada is facing a great shortage of labor at time when the Mother Country is calling to her children of the New World to grow a greater abundance of food stuffs. Canada has rallied nobly and loyally to the colors—her sons have written her fame and heroism on a hundred bloody battlefields of Europe. History will ring with the stirring deeds of Canadians.

But Canada must rally to the harvest—her reapers must cut full swaths—her threshers must save every kernel—for every kernel is a nugget of gold this year. The war is a war of exhaustion. A million bushels may turn the tide. Stranger things than this have happened in history. Will you be prepared?

**Hart-Parr Company will help you be prepared to win the harvest.**



## A Money Maker Separator Will Save Your Grain

The only separator that is double leather belted, double eccentric driven and has a ratchet driven wind stacker fan. It is built by one of the oldest separator manufacturers in the world and is all that its name implies. A Money Maker for the farmer because it puts the grain in the sack instead of in the stack.—A Money Maker for the thresherman because it runs easier and steadier—costs least to run—threshes faster and cleaner.

This separator in connection with a Hart-Parr Tractor makes the best combination outfit on the market. Ask us to tell you about the five tooth track in the fifteen bar cylinder; the undershot fan with the wind and blast boards; the conjunction of two section racks; two section grain pan and double reciprocating racks; the spring mounting on the rear axle; the hexagon taper shank seated steel teeth. The eccentrics alone provide over 77 square inches of bearing surface as against only 25 in the crank shaft type, and make it much easier to take up lost motion on the parts they drive. They eliminate undue vibration. The grain pan is built in two pieces with no chance to warp or sag. The arched roof deck sheds water like a duck's back. You do not have to crawl inside the machine to oil or adjust it. All adjustments and oiling are done from the outside of the Money Maker. There are more distinguishing features of merit on this separator than on any other. And the price—it's remarkably low despite the many superiorities of the machine.

We have a hand-somely illustrated two-color booklet that will give you full information. It will pay you to write to-day. When writing ask us to send you our two-color feature circular in Old Reliable.

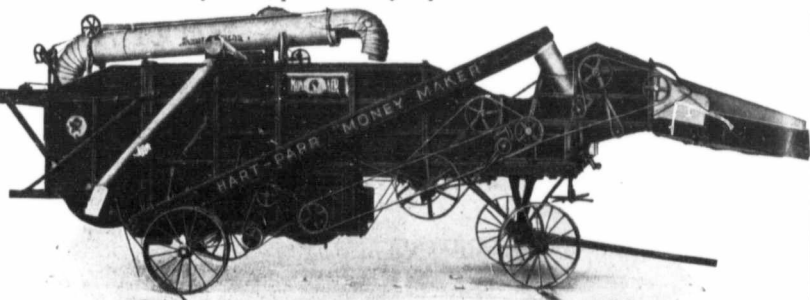



.....  
 Write for Free  
 Booklets  
 .....  
 Get the Whole  
 Story  
 .....

.....  
 Write for Latest  
 Information  
 .....  
 Get the Whole  
 Story  
 .....

C. W. HART, Founder of the Oil and Gas Tractor Industry—Greatest Living Authority on Tractors—Designer of Hart-Parr Tractors.

You will admit that a tractor fills the bill—that it takes care of the great labor shortage. Then what kind of a tractor will it be?

**YOU WANT**

A TRACTOR that burns kerosene—that saves hundreds of dollars on your fuel bills. *It's written in the contract that Hart-Parr tractors burn kerosene. See that it is written in yours.*

A TRACTOR that is oil cooled—that saves the expense and delays in filling your radiators four times a day in hot weather and draining them whenever the tractor is idle in cold weather.

A TRACTOR with single lever control and brake on belt and traction—a tractor with only four gears used in straight-away motion—a tractor where you do not shift a single gear—a tractor with valve in head motor and extra large bearings.

A TRACTOR that is accessible—such a one that you can lift a hinge cover and remove a piston if necessary, in ten minutes time—can take up a main bearing from the outside—a tractor with ground, instead of packed joints—a tractor with great reserve power and light weight—a tractor with wave form lugs on drivers, having 31% greater bearing surface and that do not injuriously pack the soil.

A TRACTOR that has been tested longer than any other tractor built—that has been improved for 14 years—a tractor backed by the oldest builders and a great service organization—a tractor that will never be thrown in the scrap pile orphanage.

**It's Old Reliable—The "Oil Powerful"**

Such a tractor is the ideal for the Canadian farmer. That kind of a tractor is Old Reliable. Its average life is 10 years—average repairs less than 3%.—It's ready for the battle to win the harvest against the great shortage of help. A postal brings full information.

**Must be "Made of Sterner Stuff"**

Not so with the pony tractor that has so called attachments to burn kerosene. Attachments are excuses—makeshifts. A kerosene motor must be especially designed and built. It cannot be made in a day. "Country Gentleman" says:

"A great many of these little fellows were under powered, even for their weight at the start. Some of them still are. The great need for surplus power was not fully understood. How could it have been otherwise when the rush products that were flung on the market had practically no testing out."

"Motor World" says:

". . . . In Iowa a large majority of farmers claim they cannot burn kerosene successfully . . . that using kerosene means more than a change in the carburetor."

The tractors that will meet the critical conditions in Canada to-day must be "made of sterner stuff."

There are six sizes of Hart-Parr Tractors—all burn kerosene. Old Reliable leads. It pulls eight plows in stubble, five 8-foot binders and drives a 40-inch separator fully equipped.

**HART-PARR CO.**

PORTAGE LA PRAIRIE, MAN. CAN. - REGINA, SASK. CAN.  
 SASKATOON, SASK. CAN. HOME OFFICE, CHARLES CITY IOWA U.S.A.



### Some Problems in Growing Pure Seed

By JOHN BRACKEN,

Professor of Field Husbandry, University of Saskatchewan, Saskatoon.

"Good seed" like many other expressions that have slipped into our agricultural vocabulary, is a term that, through over-use, has lost much of its definite meaning to most of us. In a general way we all appreciate "good seed." It has become popular to talk about it and to recommend its use, but it is a term that has been spoken of too lightly; it has been written about so freely that it has become hackneyed; it is an expression that is on all our lips, yet many it has no specific meaning.

"Good seed" is nothing more nor less than seed.

1. That will grow.
2. That will grow vigorously.
3. That is free from noxious weeds and other impurities.
4. That is free from disease.
5. That is from a suitable variety, and
6. That is well bred.

It may possess other "fancy" points, but these are fundamental. They include the only really important things we desire in the seed we sow. The standard for seed is not the standard for the market. The sample that meets one standard may also meet the other, and this is often the case, but it need not necessarily be so.

Aside from the ordinary problems connected with the growing of crops, the other problems face the man who would produce good seed for his own use, and an additional one faces him who would produce good seed as a business enterprise.

#### Get a Right Start

The first problem is to get a right start. This is a very important step, yet it is the simplest of the three. No one in this audience will have difficulty in choosing seed that will meet the first four of the requirements mentioned. The germination test and a careful examination for impurities and diseases is all that is necessary generally to accurately size up a sample under these heads. Only the presence of loose smut in cereals and wild in flax cannot with accuracy be determined in this way. The evidence of the producer must be accepted or an examination of the growing crop made in order to satisfy oneself more positively regarding these points.

In choosing the variety two

sources of information may and generally should be drawn upon (1) the nearest experimental farm where the varieties are tested out side by side, and (2) one's own experience and that of his neighbors. None but standard varieties should be used. The characteristics of those are quite well known to-day. The experimental farms are paid to test the relative merits of old and new sorts. We should not only expect them to do this work, but we should require that they do it so well that we need have no hesitation in accepting their conclusions. This may mean for the new varieties the instituting of outside co-operative tests in addition to those carried on at the experimental farms. All the information one needs concerning our present standard sorts is now known and is available.

A suitable "variety" is not enough. All registered Clydesdales are not necessarily well bred, but all these are good Clydesdales. Neither is all Marquis, nor all Red Fife well bred. A considerable quantity of the seed of these crops now being used contains a mixture of other varieties. Much of the Marquis first distributed is now found to contain many non-typical forms a large number of which have come from Marquis itself. The new strains of this variety are "pure," that is nearly all plants come true to the Marquis type.

All our old varieties are continually being improved by the elimination of the less fit and the selection and propagation of the most fit, and also by the more intricate and slower process of artificial crossing followed by selection. This work with our commonly grown field crops is being done chiefly by the experiment stations, although all of the C.S.G.A. members are making mass selections and few are following the plant row or pedigree system. None to my knowledge are doing crossing work. But whether a strain is produced by the experiment station or a private individual it should seldom or never be chosen until reliable data concerning its behaviour as compared with standard sorts is available. The seed grower should have well bred seed and

## THE FATTEST THING

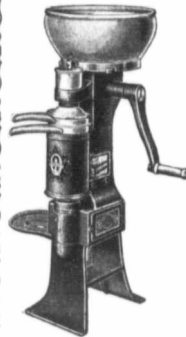

in farming profits is the butterfat fund. You can build up a bigger bank account from MILK ESSENCE than from any other main line or side line in mixed farming. But it must be the real milk—ESSENCE—the concentrated substance of the best the cow can make. You can't get it by ordinary machinery, far less by hand skimming but you can get it by separating with a

## "MAGNET" Cream Separator

In point of service it is the cheapest separator made.

### THE MAGNET

#### The Clean SKIMMER

is not the lowest priced machine made but it is the best value in any Cream Separator known. Quality, Character and the highest possible efficiency is first guaranteed by the severest tests, then a modest profit to the manufacturer is added over bare cost of material and construction.

The "Magnet" is made in Canada by Canadian engineers who have first of all gained their experience on Canadian dairy farms in all essentials to a separating machine that fits in perfectly and economically to every requirement. The result is the "Magnet"—a separator that more than fulfills the last promise made in its name.

We will easily prove what we say by showing you the "Magnet" in your own dairy. The design and construction of the machine is what has compelled us to double the output of our factory this year.

## The Petrie Mfg. Co. Ltd.

Head Office and Factory: Hamilton, ONT.

WINNIPEG, CALGARY, REGINA, VANCOUVER, MONTREAL, ST. JOHN, EDMONTON, LETHBRIDGE

## "Cant-Sag" Gates Cost Less For FREE Last 5 Times as Long CATALOG

We'll save you big money on your farm gates. Our catalog quotes such astonishingly low prices on CANT-SAG GATES and GATE STEELS that you simply can't afford to build another clumsy, all wood gate. Our PRICES are less than what others charge for short-lived steel, wire and gas gates.

### 30 Days' Free Trial—5 Year Guarantee

We give 30 days' free trial and a signed 5 year guarantee. Send for our big Free Gate Catalog at once—see why CANT-SAG GATES outsell and outlast all others. When you get this book you can either select complete CANT-SAG GATES, ready to hang, any height, any length—painted or unpainted or if you prefer you can order just the GATE STEELS (which includes everything but the boards). With these you can build your own gates in 30 minutes and save big money.

Send for FREE Gate Catalog Today

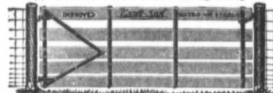

**Note These Special Features**  
Each board double bolted between 4 pairs of ANGLE STEEL uprights and 4 TRIANGULAR TRUSS BRACES. Patent reinforced SELF-LOCKING HINGE. Gate swings easily both ways—always hangs square and plumb. Elevating at the bottom, (fringed at side) allows quick removal of gate. Write for Free Catalog. RADFORD-WRIGHT CO., Ltd., Winnipeg, Man.

## DONALD MORRISON & CO.

ESTABLISHED 1904

GRAIN COMMISSION  
GRAIN EXCHANGE  
WINNIPEG

WE handle Wheat, Oats, Flax and Barley on Commission, obtaining best possible grades and prices. Our work is prompt, accurate and reliable. Let us handle YOUR shipments this season. Daily or weekly market letter on application.

References: Bank of Toronto, Northern Crown Bank and Commercial Agencies.

Dr. Thomas' Eclectic Oil  
Relieves all Pain in Man or Beast  
25 Cent Bottles at all Dealers



Pat: "A"



the latest highly recommended strains of his favorite sort should be made accessible to him.

**Keep Going Right**

Having made a right start, the second problem—and this is the most persistent and demands the exercise of the greatest patience and ability—is to keep going right. Most of us sooner or later experience serious difficulty in keeping our seed "pure." Weeds and other classes of crops and other varieties get into the sample. Most other problems pale into insignificance beside this. The maintenance of purity is the constant bugbear of the seed grower.

The question of clean seed involves the whole question of crop production—the crop management practices followed, the tillage of the land, the rotation, the system of farming, and the neighbors and their system as well as the kind of fanning mill and the frequency of its use. It is too big a question to be answered here. We can only point out some of the pitfalls that others have discovered.

Admixtures must be prevented. These occur in many ways—volunteer plants from a previous crop visible seeds in the manure of horses and other stock, occasionally by soil drifting, the co-operatively owned or neighborhood threshing machine, the neighbors stock, the granary, the fanning mill.

To indicate this is to suggest the means of prevention. Every single cause of admixture can be easily controlled. Yet when all of these and more besides must be contended against at the same time it becomes a much easier matter to tell how than to meet and overcome the difficulties presented.

Weeds must be controlled. Some of us have only to prevent weeds, but most have to control the thousandfold we did not pre-

vent. We get weeds by sowing dirty seed (usually secured from the government or from our neighbors), by drifting soil (also from the neighbor's farm), the threshing machine and wandering stock, neither of which is ours. But we got the weeds and they are with us yet. We must control them if we are to grow good seed.

We have been depending too much upon the fanning mill and more thorough tillage and perhaps a seed plot and some hand picking to withstand these pests. With none but these practices to help us we have been playing a losing game. The weeds are gaining on us. The cost of growing crops is increasing. We have fought a good fight, but we are losing ground.

Our yields are decreasing—showing it is true. The cost of production increases with the increase in weeds. If we did not get rich before, we shall not do so in the future if we follow the old methods. Our sins and the sins of our predecessors are being visited upon us.

The way out is not clear, yet we are not without some light to guide us. The use of a suitable crop rotation is the most efficient method of combatting annual and biennial weeds. Live stock will aid in controlling many more. When crop rotation and live stock control weeds they do so at no cost to the farmer. They lower the cost of production. In fact live stock may change one item of cost—viz., weeds, to an item of profit.

In our opinion we shall control the present situation when we adapt our system of farming to meet the conditions that have caused and are now causing low yields and poor quality in our crops. That adaptation will include a rotation of crops which will aid in controlling weeds and drifting soil, in lessening the cost

Clean Skimming  
Easy Turning  
Easy Washing  
Small Repair Cost  
Best Cream Quality  
World's Highest Awards



## DE LAVAL

### Stands On Its Record

**F**OR nearly forty years the De Laval Cream Separator has led in the cream separator field. It was the pioneer in 1878. It had a long start and has always held its lead. It has always led in every step of cream separator development and popularity, and more De Laval are in use today than all other makes combined.

It has always been recognized as the closest skimming cream separator. That's the main reason why 98% of the world's creameries use it to the exclusion of all others.

Because of its cleaner skimming, ease of operation and wonderful durability, every De Laval user is a "booster" and the better its work is known in a neighborhood the more popular it becomes.

The better quality of cream it produces is attested by the fact that De Laval produced cream and butter have scored highest at every annual contest of the National Buttermakers' Association for twenty-four years and in every great representative contest for over thirty years. Last but not least, the De Laval was awarded the Grand Prize at the San Francisco Exposition in 1915 as at every other great exposition since its invention.

The creamerymen's choice can't be far wrong. The world's greatest dairymen and mechanical experts who act as judges at the great expositions can be depended upon to recognize real merit, and the fact that the De Laval is the choice of the majority of all cream separator buyers must mean a good deal to you. In your purchase of a cream separator can you afford to ignore these considerations?

Let the De Laval start saving cream for you right now. See the nearest De Laval agent at once, or if you do not know him write us direct for any desired information.

**GRAND PRIZE**  
Highest Possible Award  
PANAMA-PACIFIC EXPOSITION

**DE LAVAL DAIRY SUPPLY CO., Ltd.**  
MONTREAL PETERBORO WINNIPEG VANCOUVER  
50,000 BRANCHES AND LOCAL AGENCIES THE WORLD OVER



**DOING HIS OWN COMMISSARIAT**  
Pat: "Are these cakes to-day's, miss?—because yesterday's weren't."



26 babies poisoned in 11 states; fortunately some recovered.

## Save the Babies

### TANGLEFOOT

Catch the disease carrying fly that strays into your home with safe, efficient, non-poisonous **TANGLEFOOT**; not arsenic poison in an open saucer set within reach of the baby, or a can from which a poisoned wick protrudes, sweetened to attract both flies and babies.

Flies kill many babies, and fly poison more than all other poisons combined—

—But in homes where careful mothers have protected their babies from such risks by using only **TANGLEFOOT**, both dangers are avoided.

The Journal of the Michigan State Medical Society reports 26 cases of arsenical poisoning from fly destroyers in 1915 in only 11 states; in 1914 there were 46 cases in 14 states.

It states editorially:

"Symptoms of arsenical poisoning are very similar to those of cholera infantum; undoubtedly a number of cases of cholera infantum were really cases of arsenical poisoning, but death, if occurring, was attributed to cholera infantum.

"We repeat, arsenical fly destroying devices are dangerous and should be abolished. Health officials should become aroused to prevent further loss of life from their source. Our Michigan Legislature, this last session, passed a law regulating the sale of poisonous fly papers."

Made in Canada by **THE O. & W. THUM CO.**, Walkerville, Ont.  
American Address: Grand Rapids, Mich. (65)

of production and in building up a more permanent agriculture. It will necessarily include live stock to make use of the forage crops that must be grown, and to lessen the amount and thereby the cost of the tillage necessary to control weeds.

It would seem that the rotation should include a grass or grass-legume crop to aid in the control of annual and biennial weeds and an intertilled crop to help fight perennial weeds. What these crops are to be and the sequence they will follow, you and your experiment stations must work out. Corn, alfalfa, Western rye grass, timothy, winter rye, beardless barley, and possibly red clover, together with the cereals now commonly grown seem at present to offer the greatest promise.

Such a change on all the farms in Manitoba will require an initial outlay of enormous capital for fencing, buildings and stock. We shall have to make the greater part of this money ourselves. Our problem then will be solved but slowly. Nevertheless it will be solved. It is largely a rotation, a farm management and an economic problem. The purely agronomic or crop and soil phases of it are the least difficult to answer.

**The Good Seed Market**

The third problem in growing good seed does not affect the man who grows only enough for himself, but very seriously affects the one who is making seed growing his business; and incidentally it affects the state either favorably or adversely according as the best seed reaches the sower or is sold for purposes other than reproduction.

Good seed will sell (1) if it is better than other crop growers are using, and (2) if farmers generally are convinced that it is better. We must first demonstrate that our seed is really improved and then we must take such steps as will let growers know the truth about it.

The field grain competition is the best place to demonstrate our goods. The seed grain fair is another but much less valuable place. A sample of undesirable seed can be cleaned and prepared to win a prize, when it may yet be unworthy. A field does not lend itself to manipulation in this way. Publicity may be obtained at the agricultural fair and the provincial show. The report of the seed inspector is an evidence of what you have. The district representative and the local public officials should be shown what we are doing, or at least kept informed of our results.

A good demonstration is the best advertisement. Co-operative advertising made possible by forming seed centres is good. Private advertising is sometimes advisable. The winning of prizes

for fields or for grain is the most effective means of finding a market.

A list of the growers of good seed, together with field reports on the character of their work should be made every year and kept accessible to purchasers. If we can produce a supply of good seed year after year and keep it up, a provincial association such as this, with the co-operation of the Canadian Association, should be of material assistance to us in disposing of our stock at a reasonable price, providing our output is not inferior to the representations made concerning it.

**Preparedness on the Farm**

Continued from page 34

presented more of a problem as there was not room between them and the picker wheel for plates to be riveted on. It was finally solved by drilling half inch holes through the web right in the cracks, tapping them and screwing in plugs tightly, which were then cut off and headed over so that they were flush with the surface. At last accounts the owner was still using the machine.

Every machine on my own farm has been fitted with hard oilers wherever they can be used, the plow, cultivator, disc harrow, binder, etc. Some machines that were not working satisfactorily have been practically remodeled. Three machines there are in almost constant use were made complete in my own shop; a garden cultivator that was worthless was made over entirely and is now quite satisfactory and a garden drill is being made that will be a big improvement over the one bought a few years ago.

It is impossible in the space at my disposal to give more than a suggestion of what may be done in the farm shop; hardly any two jobs of repairing are alike. In addition to the repairs, many small and some quite large articles have been manufactured complete. The list includes a two horse cultivator, a harrow attachment for a sulky plow, gambrel hooks for beeves and hogs, wire stretchers, odd bolts of all sizes, stud bolts, picket pins, pipe nipples, gate hinges, ironing boards, fly traps, saw arbors, shafts for various machines, desks, book racks, tables, chairs, etc., etc. It will be observed that the list is a varied one. With the exception of the saw arbor and the machinery shafts, none of the work required costly tools or any very high degree of skill.

In addition to the shop work, all the carpenter and mason work on the farm has been done for many years by the writer. One of the first jobs to be tackled after taking over the management of the farm was the dismantling and re-

**STEAM and GAS ENGINE Short Courses**

Manitoba Agricultural College June 13 to July 31st, 1916

The object of these courses is to enable farmers to become competent engine operators. Besides engine instruction and practice, the course will include belt lacing, babbitting, making and fitting keys for pulleys, soldering, blacksmithing, etc.

As only a limited number can be accommodated, those desiring to take the course should apply in good time and have applications accepted before coming in.

WRITE FOR DESCRIPTIVE CIRCULAR THE PRESIDENT, MANITOBA AGRICULTURAL COLLEGE WINNIPEG



**Money Savers for Farmers**

**Seven short appeals to "horse sense"**

ANY man can make money by judicious saving. "A penny saved is a penny earned." Think it over. There are certain things you ought to have for farm maintenance. But don't buy the wrong thing at any price or the right thing at the wrong price. Perhaps right now you are in need of a timber preservative, a lice or fly killer, a durable paint for metal and exposed wood surfaces, a satisfactory cement for quick everyday repairs, a ready roofing that is wear-proof, easy to lay and cheap.

We can fit you out perfectly in these things. The Barrett Money Savers have no superiors. Just glance over the products shown below:

ARE you getting all you should from your live stock? Perhaps they are being pestered by insects—flies, lice, vermin. They must be kept clean. Spray your cows and horses with Creonoid. Keep them from insect annoyance. And your hogs will be better if the rubbing posts and wall pails are Creonoided. A boon in the poultry house—better hens—more eggs. Creonoid comes in cans of 1, 5 or 10 gallons or in half barrels and barrels. And it's the most economical you can buy. Follow directions carefully.



DO your implements rust? If so, they are decreasing in value. Coat your implements and iron work with Everjet Elastic Paint. You know that carbon paint is best for such purposes. Well, Everjet is the best carbon paint made. Never cracks or peels. Wears like iron. Has a large covering capacity and is extremely economical. Has no equal as a roof paint.



YOU will be glad for the day when you meet Everlastic Roofing. Just the thing for all farm buildings. The best "Rubber Roofing" at the price. And the price is low. No excuse for a leak in your roof with Everlastic at your service. It is tough, durable and easy to lay.

**EVERLASTIC ROOFING**

CARBONOL is a household wonder. It cleans, heals, disinfects, purifies. If you cut your hand, apply Carbonol in weakened solution. If your live stock get bruised, Carbonol will fix them up. If your house, barn or poultry house needs disinfecting, there is nothing like Carbonol. And it is wonderfully effective as a destroyer of vermin. Carbonol belongs on every farm in Canada.

HERE is a ready roofing that needs no painting or other attention to keep it watertight. Amatite Roofing has a mineral surface that laughs at wind and weather. Very attractive because of its bright sparkling appearance. Wherever you have steep roofs, you need Amatite. Amatite is made in rolls of 110 square feet with galvanized nails and cement in center. Try it!

HERE is a product you should never be without—Barrett's Grade One Creosote Oil. It is the most effective wood preservative on the market. Actual tests have proved that it penetrates deeper and lasts longer than any similar product. A good fence post will last 20 years if painted with Barrett's Grade One Creosote Oil. Use Grade One Creosote Oil and add to the life of all your exposed woodwork.

HERE is the way to make everyday repairs quickly, permanently and cheaply—use Elastigum, the adhesive, elastic and waterproof cement. Whenever you have gutters to join or reline, leaks or joints to seal, cornices to stuff, greenhouse glasses to put in or chimney flashings to renew, Elastigum will be your unailing friend. Cheap, easy to use and always on the job.



Send for illustrated booklet describing Barrett Money Savers in detail. Address nearest office. For sale by good dealers everywhere.

THE PATERSON MANUFACTURING COMPANY, LIMITED  
MONTREAL TORONTO WINNIPEG VANCOUVER  
THE CARRITTE - PATERSON MANUFACTURING CO., LIMITED  
ST. JOHN, N. B. HALIFAX, N. S. SYDNEY, N. S.

build was fort hied the grou it w hand was being there be de I t I say per e ment. effort some re I ma keepi know more, whose in his is pro fence, and la portan things as thro Who ster, he the far age, but mighty Would brought heart? since b good p along, s opened t more too to time seemed s became room wa additions nearly se There a 3-horse shop tool which gri shells cor screw-cut wheel, a l disc shurd hundres



"Hold 'em

building of a large barn. As it was a structure thirty-four by forty-four feet and thirty-five feet high, and the barn as rebuilt was the same dimensions on the ground and twenty-five feet high it will be seen that the ability to handle tools effected a saving that was not to be despised, the work being done in the winter when there was but little else that could be done.

I think I am conservative when I say that my tools pay twenty per cent dividends on the investment. In addition to the saving effected it is a source of considerable pride to be able to point to some building or a piece of furniture and say, "That is something I made myself." As a means of keeping the boys on the farm I know of nothing that will help more, it being an unusual boy whose fingers do not at some time in his life itch to handle tools; it is good training, it teaches patience, care and thoughtfulness, and lastly, perhaps, the most important of all, it teaches one to put things where they belong as soon as through using them.

When the writer was a youngster, he vowed that he would leave the farm as soon as he became of age, but he is still on the farm and mighty glad, indeed, to be there. Would you care to know what has brought about the change of heart? I have been buying tools since boyhood but never had a good place to keep them, but along, about 1904, the way was opened up, a good shop was built, more tools were bought from time to time until the building which seemed ample at first for all time, became so crowded that more room was imperative. With the additions, the shop now covers nearly seven hundred square feet.

There are two gasoline engines, a 3-horse power which runs the shop tools and a 6-horse power which grinds feed, saws wood and shells corn. The shop contains a screw-cutting lathe, an emery wheel, a blacksmith's drill, and a disc sharpening machine, besides hundreds of small hand tools and

an almost endless array of such things as bolts, screws, rivets, nails, bar iron, and other articles too numerous to enumerate.

As I remember it, when a boy, grinding feed was about the worst chore that ever bobbed up; now-a-days, all we have to do is to shovel the grain into a hopper that holds a wagon load, start the engine, pull out the slide and sit down while the engine does everything but keep the ground grain back from the spout of the elevator. If "Dad" had had such an outfit when my brother and I were boys he would have found it necessary to tie us up to keep us from grinding everything on the place.

The pole saw is probably the greatest labor saving device on the farm. (The saw frame is homemade, of course.) With its aid old piles of sticks, fence posts and dead trees are quickly worked up into stove wood, a pile of wood is made ready for the good wife the farm. The saw frame is better by a hundred per cent.

A farmer simply cannot afford to be without tools and at least one gasoline engine. Come and see me and let me prove it.

A strong will, a patient temper, and sound commonsense, when united in the same individual, are as good as a fortune to their possessor. Barring untoward accidents, the man endowed with these qualities who starts on his career with a determination to reach a desirable position is certain to reach it.

Anything that can't be multiplied or added to so that it equals a stair-step to progress you'd better let alone.

I've heard men criticize the way the Government was running things when their wives made the family living.

A rolling stone is all right if you can only make it roll up hill.

Consider the lilies of the field—the strongest thing they drink is dew.



"Hold 'em for another minute, Bill, an' we'll have milk for the whole squad."



**"My ALPHA is the most reliable worker and best helper on my farm"**

**ANY farmer who is using an Alpha will tell you that this engine is a great help to him and that he can absolutely rely on it. The Alpha is a steady, powerful engine that will do a great number of big and little jobs on your farm that now cost you too much in time and labor. You can make your work easier, get it done quicker and save money by using an Alpha.**

The Alpha is a smooth running, powerful engine that has proved its value to thousands of farmers in all parts of Canada. It is a reliable engine. You can always depend upon its being in good working order when you want to use it. There are no complicated parts to get out of order and cause time-wasting delays and expensive repairs. Ask Alpha Engine users. What they tell you will be proof of Alpha superiority.

The Alpha starts and runs on a simple magneto. You get a hot, fat spark at all times. You are never troubled with weak batteries. You can use kerosene or gasoline for fuel. The fuel consumption and speed of the engine are accurately controlled by a reliable, sensitive governor. This governor acts the instant there is the slightest variation in the load. Therefore, the engine runs steadily at all times and there is no waste of fuel. The Alpha is not affected by cold weather.

There are many other reasons why Alpha Engine users get the greatest engine value for their money. Every feature of the Alpha is completely illustrated and described in our large engine catalogue. Ask for a copy and read it carefully.

Alpha engines are made in eleven sizes—2 to 28 H. P. —each furnished in stationary, semi-portable or portable style with hopper or tank cooled cylinder.

**DE LAVAL DAIRY SUPPLY CO., Ltd.**

LARGEST MANUFACTURERS OF DAIRY SUPPLIES IN CANADA.  
Sole Distributors in Canada of the famous De Laval Cream Separators.  
Manufacturers of Ideal Green Feed Silos. Catalogues of any of our lines mailed upon request.

MONTREAL   PETERBORO   WINNIPEG   VANCOUVER

## UNION BANK

OF CANADA

**Open a Housekeeping Account and pay your Bills by Cheque**

There is a decided advantage in depositing your housekeeping money in the Union Bank of Canada, and issuing Cheques for your expenditures. You avoid the risk of keeping a considerable sum in your home or carrying it when shopping, and each cheque, when cashed, becomes a receipt.



Head Office, Winnipeg  
Total Assets over \$90,000,000  
Deposits over \$72,000,000

Over 315 Branches in Canada.  
Over 40 Branches in Manitoba.  
Over 90 Branches in Saskatchewan.  
Over 50 Branches in Alberta.  
Over 20 Branches in British Columbia.

**Family Group Photos a Specialty**

—AT—

**STEELE & CO., Ltd.**

MAIN ST. and BANNERMAN AVE.      WINNIPEG

# Handling Stubble Land

The Big Problem before Saskatchewan Farmers this Spring  
By JOHN BRACKEN, Professor of Field Husbandry,  
Saskatchewan University.

Five and a quarter million acres of stubble land in Saskatchewan have not yet been plowed for the 1916 crop. Over three and a half million acres have not even been disced.

With this large amount of work on hand and the spring season opening up later than in the average year, it is manifestly impossible to plow all this land, or even to give it thorough tillage of any other kind. Yet upon the solution of this question depends very largely the yields of the 1916 crop.

A summary of the conclusions arrived at as a result of hundreds of tillage tests on stubble land at Saskatoon is reported in a circular published by the Department of Field Husbandry of the University. This circular which contains many valuable suggestions relating to this question may be had by applying to the College of Agriculture at Saskatoon or to the Department of Agriculture at Regina.

The following are a few of the conclusions that relate particularly to the spring preparation of stubble land and that are therefore important at this time:

1. All stubble land that contains creeping rooted grasses in any quantity should either be plowed before seeding or left to be fallowed.

In this connection it is pointed out that wheat and grass cannot do well together and that plowing is necessary to control of grass. In one test the plowing of grassy land produced thirteen bushels more oats and four bushels more wheat than discing. If any stubble is to be sown without tillage it should be that portion that is free from creeping rooted grasses.

2. The best depth to plow in the spring is the depth at which the best work can be done.

In some years shallow plowing and in others plowing at a medium depth proved best. It was generally true that plowing to the depth at which the best work could be done gave the largest return.

3. If wheat is to be seeded on spring plowing, the latter should be done as soon as possible after the land is dry enough to plow.

Oats, barley and flax may be seeded on later plowing, but even these will do best on relatively early plowing. The chief objections to spring plowing arise from those who have not power to get it done in good time, and have therefore to sow later thus reaping the ill effects of late maturity.

4. All plowed land should be thoroughly harrowed and well firmed down at the earliest opportunity after plowing.

Most of the moisture in the furrow slice can be conserved by harrowing, and the moisture in the subsoil can be made available to plant roots by firming the furrow slice against the subsoil. Immediate harrowing after plowing increased the yield of wheat one bushel and fifty-seven pounds, while packing deep plowing increased the yield two bushels and six pounds and packing shallow plowing increased the yield forty pounds per acre.

5. The sooner the seed can be put in after the land has been plowed and surface cultivated the better the germination will be.

6. The rate of seeding should be rather less than is used on fallow and should be determined by the amount of moisture in the soil. The greater the moisture supply



MUCH TO BE THANKFUL FOR

Visitor: "I think it's just wonderful to see you cheery with all those horrid wounds on your head."  
Wounded Optimist: "Oh well, miss, it's a very cheerin' thing to wake up of a mornin' an' find that you've still got a 'ead to 'ave wounds on!"



On every outing—

# KODAK

Let pictures taken add to the delights of country life. Every day in the open, every picnic party is made merrier if you Kodak—and afterwards comes the pleasure in the pictures themselves, and picture taking is less expensive than you think.

Illustrated catalogue of Kodaks and Brownies, free at your dealer's, or by mail

CANADIAN KODAK CO., LIMITED,

606 KING STREET, W., TORONTO

## Let the "Judson" Handy-Boy

Pump Water for your Stock. Saves time, saves labor.

Start up this Pumping Outfit and it will keep right on furnishing barrels of pure water for the stock while you leave it and go about your other work. You don't have to touch the pump handles. (Prices do not include pump). This illustration represents the "JUDSON" Handy-Boy, 1 1/2 h.p. with self-starting Magneto, and our No. 2 double geared all iron Pump Jack with belt already lined complete and ready to work. Shipping weight, 450 lbs. Price \$53.50. Price of outfit with batteries, \$53.50. Wire Fencing that you can feel safe about. Stock Tanks of steel, as well as other labor-saving equipments and farm supplies in our general Catalog. Send for a copy today.

Sellers of High Grade Farm Supplies direct to the farmer

C. S. Judson Co. Ltd.

WINNIPEG, Canada



## GREAT INVENTION

**GASOLINE** produced at less than 9c. a gal. Two tablespoonfuls of Gaso-Tonic for 5 gal. Half measure for Ford Autos. Equally good for gasoline and kerosene engines. Will increase your horse power; also increase mileage 25% on the average. Guaranteed. Trial \$3.00. Agent's outfit \$6.00. Agents wanted everywhere.

Address—

F. S. EXCHANGE, LTD., Neville, Sask.

and the seed sl ver-a. seed ver to brin early, bi conditio yields.

7. Favorabl and disc success.

By meant, and a so

8. In stubble, weeds, a lake, but cultivatic proven in permaner water an

This largest ne soil at Sa three yea two crop wasteful c constitute organic m

9. Wi quass on l thorough with disc to conseri and prepar

10. Di long stubb the surface feres with spring.

Under t should citi depth, or If time is present, the out tillage.

11. In plowed sti practice exc been thoro and year 1 from perc weeds and condition.

12. Har of small wee This will done in dr weeds are sn the ground.

13. The three years ods of tillin baton are a Grassy st acre, 7 bus. Clean stul 12 bus.

Normal s rated with d bus, 56 lbs. Normal st spring and v bus, 30 lbs. Normal sti spring and w bus, 54 lbs. Normal sti

and the later the date, the more seed should be used and vice versa. In case it is necessary to seed very late more seed will help to bring the crop to maturity early, but thick seeding under dry conditions often results in lower yields.

7. *Unplowed land may under favorable conditions be burned and disced with prospect of fair success.*

By favorable conditions is meant long stubble, no grass and a soil that does not bake.

8. *In the presence of long stubble, little grass, few biennial weeds, and a soil that does not bake, burning followed by surface cultivation is a practice that has proven immediately profitable but permanently wasteful of organic matter and nitrogen.*

This method has given the largest net returns on a new rich soil at Saskatoon when used in a three year rotation—fallow and two crops—but it is extremely wasteful of the two most valuable constituents of western soils—organic matter and nitrogen.

9. *With short stubble and no grass on land that does not bake thorough surface cultivation with disc and harrows will help to conserve moisture, kill weeds and prepare a seed bed.*

10. *Discing fields that carry a long stubble creates a nuisance on the surface of the field which interferes with proper seeding in the spring.*

Under this condition the land should either be plowed a fair depth, or burned and cultivated. If time is lacking and no grass is present, the land may be sown without tillage.

11. *In general seeding on unplowed stubble is never good practice except on fields that have been thoroughly fallowed the second year previous and are free from perennial and biennial weeds and are in good physical condition.*

12. *Harrow the growing crop if small weeds get a start.*

This will do the most good if done in dry weather when the weeds are small—just nicely out of the ground.

13. *The average yields for three years from different methods of tilling stubble land at Saskatoon are as follows:*

Grassy stubble, untilled, per acre, 7 bus. 11 lbs.

Clean stubble, untilled, per acre, 12 bus.

Normal stubble, surface cultivated with discs and harrows, 15 bus. 56 lbs.

Normal stubble, plowed deep in spring and well worked down, 16 bus. 3: lbs.

Normal stubble, plowed deep in spring and well worked down, 17 bus. 54 lbs.

Normal stubble, plowed deep in

There are many good reasons why the use of

## Dunlop Thresher Belting

is quite general throughout every threshing community.

Threshermen are beginning to realize that Rubber Belting surpasses any other kind of Belting for the work they have to do, and That Dunlop Thresher Belting embodies all the good qualities of an Ideal Rubber Belt.

Dunlop Thresher Belting is made

**By Expert Workmen  
In a Uniform Way  
From the Best Materials**

Wherein lies the secret of

**Service, Quality and Satisfaction**

Ask our nearest Branch for a sample of the Belt.

**Dunlop Tire & Rubber Goods Co., Limited**  
Head Office and Factories: Toronto  
BRANCHES:—Victoria, Vancouver, Edmonton, Calgary, Saskatoon, Regina, Winnipeg, London, Hamilton, Toronto, Ottawa, Montreal, St. John, N.B., Halifax.

fall, and well worked down, 18 bus. 4 lbs.

Normal stubble, plowed shallow in spring and well worked down, 18 bus. 21 lbs.

Normal stubble, plowed shallow early in fall and well worked down, 19 bus. 15 lbs.

14. *In case the spring season opens up very late in some sections, early classes of grain should be used, and without these the early varieties may be found to be best for this year.*

Barley ripens in fewer days than oats, and oats in fewer days than wheat. In each class there are early varieties. The six-rowed barleys are earlier than the two-rowed. The beardless and hullless earlier, though less valuable except for forage, than the six-rowed. "Dauboney," "Sixty-day" and similar varieties are our earliest but least productive oats. "Gold Rain" is the heaviest yielding medium early oat we have. "Victory and Banner" are later

but heavier yielders. "Prelude" is a very early but low producing wheat. "Pioneer" is not so early, but a heavier producer. "Marquis" is later than either, but a heavier yielder. "Red Fife" is later than all of those mentioned, and equal in yield to Marquis.

#### A Late Start

Aunt—"Why, Tommy, when I was your age a lie never passed my lips."

Tommy—"When did you begin, Auntie?"

**GET THE GOPHER**

(Campaign inaugurated by Manitoba Agricultural College).

Last year gophers were bad. The winter snow has protected them and they may be worse this year, and in the newly settled parts of the province and in the lighter soils they may at any time become an epidemic as they have in North Dakota where there are hundreds per acre.

It has been estimated that it costs over ten cents to board a gopher on your farm without reckoning the amount he destroys and the nuisance of the gopher hole, and where gophers are common, there are usually more than twenty-five of them to the acre which would amount to four thousand on a quarter section, destroying and storing away \$400.00 worth of grain, and they can be poisoned for \$1.00.

Why board gophers on your farm when they can be so easily killed? The Department of Agriculture is waging a war on the gopher this year and the Biology Department of the Manitoba Agricultural College is supplying the ammunition. The motto is "Get the gopher." Gopher posters are being sent throughout the province picturing and calling attention to the gopher trouble and the various means of getting rid of it. The farmers are urged to try every means, poison, shoot and trap, but the simplest of these means is the poison method which works early and late and at a trivial expense.

Although strychnine has advanced to \$2.00 an ounce, making it a more expensive poison to prepare than usual, the Biology Department have made arrangements for the distribution of a non-strychnine poison at a price much cheaper than a strychnine poison can be prepared. The district representatives at Roblin, Neepawa, Morden and Killarney will co-operate in the distribution of the poison, giving enough to treat eighty acres for fifty cents, and will distribute free samples of enough to treat forty acres to anyone in doubt as to the deadliness of the poison.

The Biology Department also has a field man on the job who will go to any outlying district to distribute the poison and to assist the farmers in properly applying it, and also investigate the results as the new Manitoba Game Protection Act requires that "All gopher poison must be put in the holes" (section 28), and this is where it should be put anyway. The only reason for putting it elsewhere is that the doubters may see the dead gophers lying outside the holes.

The Department is anxious that

there should be concerted action all over the province in getting the gopher just now. The earlier the easier, and the better for just now most of our wild birds have not arrived and therefore not so likely to be poisoned, and the gophers are hungry now and will eat anything, and every pair killed before breeding is as good as twenty or thirty killed in August. Let us get the gopher this year and save some municipalities \$100,000.00 and save the province from the danger of an epidemic of gophers.

In many parts of the province rabbits are reported to have done great damage this winter. The poison that gets the gopher will get the rabbit too if placed on chopped cabbage, turnips, carrots, or any vegetable of which the rabbit is fond.

**Some Spring Suggestions**

By Prof. S. A. Bedford, Chairman Weeds Commissioner for Manitoba

**Disking versus Plowing**—Owing to the small amount of plowing done last fall, there will be great inducement to put in a portion of this spring's crop with the disk. While the disc is a useful implement for the cutting up of rough, soddy land, it was never intended to replace the plow. A disc will level and pulverize the sod, but will not cut out and destroy such perennial weeds as thistles, couch grass, etc., and if grain is disced in, these weeds come up in the crop and crowd it out, greatly reducing the yield of grain and leaving the land very weedy.

**Winter Annuals**—Many of our noxious weeds belong to the class known as "winter annuals." If any of this class of weeds start to grow late in the fall, they remain alive under the snow all winter, make rapid growth in the spring and produce seed during early summer. The following are among our most common winter annual weeds: Blue Bur or Stickseed, Stink Weed, Peppergrass, Shepherd's Purse, Hare's Ear Mustard, False Flax, Ball Mustard; Tumbling Mustard and Worm Seed Mustard. If in spring any of these varieties of weeds are found growing on the summer fallow or other parts of the farm, the land should either be plowed or cultivated before the grain is sown. This warning is given because so many farmers mistake these weeds for true annuals, and, thinking that the winter has killed them, do not cultivate the land before spring seeding, with the result that these weeds, having a start of the grain, choke it out and greatly reduce the yield.

**Weeding Growing Crop**—Where the young growing grain is badly infested with such annual



Assets over \$2,500,000

Losses Paid Nearly \$40,000,000

**He's a Wise Farmer**

—who takes out a hail insurance policy. It takes a hail storm a very short time to ruin your crop—wipe out your profits, and plunge you into debt, unless you have protection in a strong company like ours

**"He Made Sure of the Money From His Crop"**

Let folks say that about you "after the storm." It is not good business to take a chance—better be safe than sorry. It is important that you select a company who have a record for fair and square dealings. During our 83 years of business we have paid out nearly 40 million dollars to policy holders who are enthusiastic about our prompt service. Let us tell you more.

Write to-day for full particulars or see our Local Agent

**British America Assurance Company**  
HAIL DEPT.  
WINNIPEG



**100,000 Farms run on his Schedule**

Put your early rising problems in Big Ben's hands—just tell him what time in the morning you want to get things stirring around your place.

dred thousand of them live on farms.

See Big Ben today at your dealer's. 7 inches tall, handsome, built to last for years. Rings two ways—once for five straight minutes, or at half-minute intervals for ten minutes, unless you shut him off. Price \$2.50 in the States, \$3.00 in Canada.

He's calling time and keeping time now for five million families—more than a hun-

If your dealer hasn't him, send a money order to his makers and he'll come direct by parcel post, all charges prepaid.

**Western Clock Co.**  
La Salle, Ill., U.S.A. Makers of Westclox

Twelve Months of this Magazine for One Dollar

we ds  
Weed,  
mustar  
stroyed  
rows o  
done v  
ground,  
quite si  
two len  
the har  
day len  
not allo  
the imp  
the grai

Fari

looks as  
come to  
the aver  
to crank  
ing the  
into tow.

Figure  
in man  
mean m  
statistics  
tor. In  
quoted c  
the amou  
the cost  
with hor  
true, but  
only thi  
farmers  
mechanic  
gressive l  
"What w  
ation on  
crops, rai  
duce mor  
ter care c  
part of o  
ehinery; i  
ter machi  
lieve that  
the power  
who has  
has use fo  
plowing o  
present pe  
sold, who  
ing, in fai  
and who c  
power.

When y  
chase fro  
some reput  
dnet, likely  
for years t  
the time th  
repairs, t  
wellbuilt  
take a forty  
turn aroun  
an experim  
low do the

New Mont

The Man  
Agriculture  
monthly bul  
ers of this  
be known  
Farmers' Li

weeds as lamb quarters, Pig Weed, Stink Weed or any of the mustards, either may be largely destroyed by the use of light harrows or weeders. This must be done when the grain is above ground, and while the weeds are quite small, i.e., while still in the two leaf stage of growth. Run the harrow or weeder on a warm day lengthwise of the drill. Do not allow the rubbish to choke up the implement, or it will drag out the grain.

**Farming a Power Problem**

(Contd. from p. 36)

looks as if such a thing might come to pass, much the same as the average farmer would prefer to crank up the auto to harnessing the driving horse for a run into town.

Figures, they say, don't lie, but in many instances they don't mean much, and this is true of statistics on the use of the tractor. In all the figures commonly quoted on the cost of a tractor, the amounts are much lower than the cost of doing the same job with horses. It is undoubtedly true, but the figures are not the only thing to consider. Most farmers are not educated along mechanical lines. As one progressive business farmer puts it, "What we need is not more education on how to grow better crops, raise better cows and produce more milk, but to take better care of the most expensive part of our equipment, our machinery; in other words, be better machinery farmers." So I believe that the right tractor solves the power problem for the man who has "machinery sense," who has use for a tractor aside from plowing only, so that part of his present power-equipment can be sold, who has land not too rolling, in fairly well arranged fields, and who can make use of belt power.

When you decide to buy, purchase from a concern having some reputation back of its product, likely to be "in the game" for years to come. Think about the time that it will take to obtain repairs. Consider only a strong well-built machine that will not take a forty acre field in which to turn around. Lastly, don't buy an experiment; let the other fellow do the experimenting.

**New Monthly Bulletin Service**

The Manitoba Department of Agriculture is establishing a free monthly bulletin service for farmers of this province, the series to be known as the "Manitoba Farmers' Library."

# Production and Thrift

"TO win the war with the decisiveness which will ensure lasting peace, the Empire will require to put forth its full collective power in men and in money. From this viewpoint it is our true policy to augment our financial strength by multiplying our productive exertions and by exercising rigid economy, which reduces to the minimum all expenditures upon luxuries and non-essentials. Only in this way shall we be able to make good the loss caused by the withdrawal of so many of our workers from industrial activities, repair the wastage of the war, and find the funds for its continuance. It cannot be too frequently or too earnestly impressed upon our people that the heaviest burdens of the conflict still lie before us, and that industry and thrift are, for those who remain at home, supreme patriotic duties upon whose faithful fulfilment our success, and consequently our national safety, may ultimately depend."—  
*SIR THOMAS WHITE, Minister of Finance.*

**PRODUCE MORE, SAVE MORE.  
MAKE LABOUR EFFICIENT.  
SAVE MATERIALS FROM WASTE.  
SPEND MONEY WISELY.**

**LET US PRODUCE AND SAVE—**

The war is now turning on a contest of all forces and resources—men, munitions, food, money. The call to all is to produce more and more. It may be necessary to work harder. The place of those who enlist must be taken by those at home, men and women, old and young. The more we produce the more we can save. Produce more on the farms and in the gardens. Save more and help to win the war.

**LET US NOT WASTE OUR LABOUR—**

In this war-time all labour should be directly productive or should be assisting in production. Make it as efficient as possible. If your labour is on something that can be postponed, put it off till after the war and make your labour tell now. Making war is the first business of all Canadians. Efficiency in labour is as important as efficiency in fighting.

**LET US NOT WASTE MATERIALS—**

Begin at home. The larger portion of salaries and wages is spent on the home—food, fuel, light, clothing. Are any of these things being wasted? \$20.00 a year saved from waste in every home in Canada will more than pay the interest on a war debt of \$500,000,000.

**LET US SPEND OUR MONEY WISELY—**

Are you spending your money to the best advantage? What do you think of extravagance in war time? Tens of thousands of Canadians are daily risking their lives for us at home. Is it not our duty to be careful and economical? Canadian dollars are an important part of the war equipment. Make them tell. Have a War Savings Account. Buy a War Bond.

**THE GOVERNMENT OF CANADA**

3

THE DEPARTMENT OF AGRICULTURE

THE DEPARTMENT OF FINANCE

The first bulletin of the series which is now ready for mailing, is written by S. C. Lee, M.A., Professor of Physics of Manitoba Agricultural College. The title of the bulletin is "Lightning Control." In this bulletin Prof Lee discusses the whole subject of rodding buildings to prevent lightning devastation. The bulletin is illustrated by exceedingly interesting original photographs, showing the way in which rats, enclosed in model buildings, were used to demonstrate the effects of rodding, the rats being killed in every case where no rods were used, and being unharmed in every case where the current turned on was not carried away by protectors.

Any farmer in Manitoba wishing the series of bulletins can have it supplied to him free by writing the Publications Branch, Department of Agriculture, Winnipeg, asking to be supplied with bulletins.

## Feed Grinders and Pump Jacks

*Sacrificed at Less than Maker's Cost*

Owing to the financial collapse of one of the oldest farm machinery houses in Canada, I am compelled to make an instantaneous conversion of these perfect goods into cash. NOTE THE PRICES—You cannot match them.

FEED GRINDERS		PUMP JACKS
6 in. Grinder, iron base	\$25.00	\$7.00 and \$10.00. Write for specifications and for any farm machinery you want. We can save you money not only on advertised goods but in every description of farm power machinery, separators, etc.
7 in. Grinder, iron base	32.50	
8 in. Grinder, iron base	43.40	
10 in. Grinder, iron base	54.00	

THESE ARE DISTINCTLY CASH PRICES

**R. S. Ewing, Assignee, WINNIPEG** 200 Union Trust Bldg.

If you are growing your own dairy cows, keep in mind that a half-starved, poorly grown heifer calf will never develop into a profitable cow.

Tack five minutes to the work of your day and go over the calves with comb and brush. It will be the best investment of time you can make.

## An Open Letter on Tractor Experience

Editor Canadian Thresherman and Farmer, Winnipeg, Man.

Dear Sir,—While in Winnipeg during bonspiel week I promised you some figures on plowing. I have not been able to submit them until now, so here they are.

In the spring of 1912 we purchased a 36-60 Gas Tractor to operate a Jno. Deere 8-bottom gang in the district north of Brock, Sask. I was up there for nearly a month during June and July that summer, and as I was around the outfit most of the time I had a good opportunity to get detailed information as to the cost of plowing which was what I was after.

At that time they were plowing from 18 to 22 acres per day, sharpening 8 shares per day and the figures are based on that. We figured the life of the engine to be breaking, 5,000 acres, or 1,000 acres per year for 5 years. After 4 seasons' experience this reckoning has proved to be not far astray as the engine has done about 3,000 acres of work, and its best days as a tractor are over.

Now I have no doubt you will question some of these figures, at least the tractor manufacturers would, as they say their engines will plow at a cost of from 30 to 75 cents per acre.

But taking them item by item you can't get past them. That land was so hard and dry that 4 sharp shares were put on—one on each double bottom twice daily to hold the plow in the ground, and sharpening shares daily soon wears them out, and it took 4 gallons of fuel per acre to pull along. These figures are facts right from the scene of action, and you can't dispute them. The wages, \$13.00 for 3 men and team and board are not out of the way, as the highest charge is for engineer, and if you save money on an engineer you pay it out ten times over in repair bills. The \$1.34 per acre for interest and depreciation is an item that I have never seen figured into the cost of plowing. Yet if a man puts from \$4,000 to \$5,000 into a plowing outfit and at the end of 5 years has used it up, it stands to reason that the interest his money might have been drawing should be added to the in-

*\*We are favored with this letter, written by Mr. H. Clendenning, than whom the Canadian Thresherman and Farmer has not a more sincere and valued friend. The Clendenning Brothers are among Manitoba's most intelligent and successful farmers, and on this account and for every other reason we can think of, their experience with the tractor as described in this letter is worthy the most careful thought of manufacturer and farmer alike.—Ed.*

vestment and charged up against the 5,000 acres.

The repair bill may seem high to you, but I think in most cases it is altogether too low, and only expert operation could keep it down to that figure. However no matter how expert the operator may be, he can't stop the wear on his gears, the shearing strains on the rivets in the frame and drivers, the wear on his friction and resultant band wheel trouble, pump wear and trouble and a score of other things too numerous to mention; and any repair list will give you a little insight into the cost of replacing any of these parts. Besides, after about 2 or 3 or 4 years of use a large percentage of gas tractors break a crank case or crank shaft, or some part of the engine that practically wrecks it for the time.

I know your next argument will be that after the land is broken up it will cost less to plow it, as it will work so much easier. And I will come right back by telling you that as soon as you put your engine on stubble you wear your gears about 4 times as fast and the draw bar H.P. is decreased considerably by the softer footing for the drivers. And then, again, the heavy drivers pack the land so that it is only by cross plowing every other year that the land can be kept level and in the best condition for growth.

The tractor business has proved disastrous, both to the manufacturers and the farmers who invested in them. Of course there are exceptions, but by far the larger number of farmers would have been far better off if they had never seen them. The tractor has had a great big part in the development of the West, but the grain men are the only ones who have made any money out of them.

The tide of public opinion is now surveying in favor of the small tractor, but any man who will stop and figure, will find out they are even a worse proposition than the larger ones, as a man can get very little more out of them than he can out of 4 or 6 horses.

The tractor has a place on every farm, but it's place is to help the horse, not to supplant him. Tractors are a necessity for threshing, and if a farmer gets behind with his plowing, but if the weather in summer-fallowing time is very hot let him put in his tractor and help the horses out, but if he can do his work with horses they will do it cheaper than the tractor can.

**Does five times the work of other poisons**

# SUREDETH

**the new scientific gopher poison absolutely exterminates.**

**Our \$1.00 package—the only size we put up—contains 25,000 doses and will cover as much ground as \$5.00 worth of any other gopher poison made.**

**"SUREDETH," the new poison—prepared in a new way, in a new form—costs less, does better and surer work and KILLS GOPHERS. Positively guaranteed.**

**"SUREDETH" can be used in gardens and pastures with perfect safety to stock and domestic and wild fowl.**

To be had from your druggist, or write us for trial package—\$1.00—and FULL instructions. Circular full describing SUREDETH, mailed on request.

**EMPIRE CHEMICAL COMPANY LIMITED**  
Dept. D SASKATOON, SASK.

**YOUR TRACTOR WILL NOT QUIT**

no matter how much work you require of it—if it is properly lubricated. For your tractor you want

## Polarine

FRICITION REDUCING MOTOR OIL

the oil that works well in any temperature—and leaves no waste to harm the engine.

Polarine oils and greases will lubricate properly every running part. Twenty-four hours becomes your tractor's working day. Polarine flows freely at zero—stands up under most intensive cylinder heat.

Buy it direct from our stations in steel barrels and save money.



Buy Gasoline and lubricants under the Premier "Red Ball" sign

**THE IMPERIAL OIL COMPANY**  
Limited  
BRANCHES THROUGHOUT CANADA

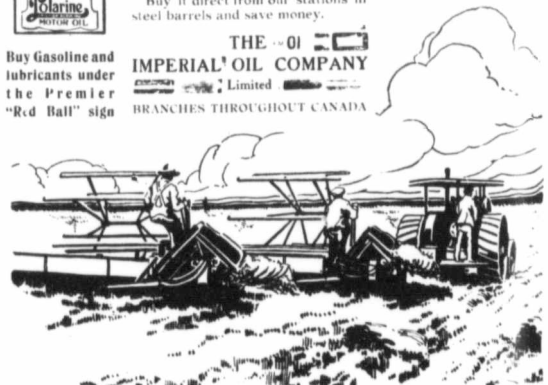

Depreci  
1,000  
Interest  
for 5  
5,000  
ment  
Interest  
depre  
Inter  
Interest  
pump  
station  
and it

Figures  
Kerosene  
19 cen  
Hauling  
per ac  
Standard  
for 20  
Axe gre  
oil, etc  
Sharpen  
repairs

Figures  
Cook and  
acre  
Engine op  
Plow oper  
1

1st 1,000  
2nd 1,000  
3rd 1,000  
4th 1,000  
5th 1,000  
To  
Per acre fo  
Total cost  
Saskatch  
You  
H

From the  
W  
Canadian

Gentlen  
year just  
ing operat  
should lik  
couragem  
I do not  
any other  
Empire w  
farmers e  
food, and  
character,  
iness of W

The Em  
to do two  
send food,  
nobly to th  
one who i  
in our agri  
if we wi  
to meet th  
Empire as  
produce.

I am very  
wailing con  
this spring,  
land ready  
of the inabil  
as much lan  
Also, many  
are wearing  
their servie  
only thirty  
ing period.  
The Depa



work  
ons

work  
ons

work  
ons

it is

and

perly  
omes  
ely at  
heat.

<b>Cost of Engine \$3,600</b>	
Depreciation on Engine, figured at 1,000 acres per year for 5 years	\$.75
Interest on investment at 8 p. c. for 5 years \$1,440 for plowing 3,000 acres, interest on investment for 1 acre would be	.29
Interest on plow investment and depreciation per acre (\$81,000 interest and investment)	.20
Interest on carboose, wagons, tanks, pumps, etc., interest on depreciation per acre (\$500 interest and investment)	.10
<b>Total</b>	<b>1.34</b>
<i>Figures based on day's work as 20 acres</i>	
Kerosene, 4 gallons per acre at 19 cents	.76
Hauling kerosene (14 gallon) per acre	.04
Standard gas engine oil 4 gallons for 20 acres at 50 cents, per acre	.10
Axle grease, gear grease, machine oil, etc., per acre	.08
Sharpening shares and plow repairs per acre	.23
<b>Total</b>	<b>1.21</b>
<b>Wages and Board</b>	
<i>Figured at 20 acres as day's work</i>	
Cook and chore boy and team per acre	.20
Engine operator, per acre	.30
Plow operator, per acre	.15
<b>Total</b>	<b>.65</b>
<b>Repair Bill</b>	
1st 1,000 acres	200.00
2nd 1,000 acres	300.00
3rd 1,000 acres	400.00
4th 1,000 acres	500.00
5th 1,000 acres	600.00
<b>Total</b>	<b>2,000.00</b>
Per acre for 5,000 acres	.40
Total cost per acre for breaking in Saskatchewan	3.60

Yours truly,  
H. Clendenning,  
for Clendenning Bros.

**From the Minister of Agriculture**

Winnipeg, Manitoba,  
April 10th, 1916.

Canadian Thresherman & Farmer,  
Winnipeg, Manitoba.

Gentlemen,—At this time of year just when the season's farming operations are commencing, I should like to say a word of encouragement to Manitoba farmers.

I do not believe that there is any other portion of the British Empire where, man for man, the farmers can produce as much food, and food of so essential a character, as in the prairie provinces of Western Canada.

The Empire is calling upon us to do two things—send men and send food. Canada is responding nobly to the call for men, but, as one who is intensely interested in our agriculture, I am wondering if we will, during 1916, be able to meet the expectations of the Empire as to the food we shall produce.

I am very well aware of the prevailing conditions on our farms this spring. We have very little land ready for seeding, because of the inability of farmers to plow as much land as possible last fall. Also, many of our best young men are wearing khaki, and at most their services are available for only thirty days during the seeding period.

The Department of Agriculture

and Immigration is doing everything it possibly can to relieve the farm labor situation. Working in harmony with the Dominion Government, we have been trying to secure as many farm laborers as possible in the United States. Up till the present moment the results have been disappointing, as the demand for experienced farm laborers seems to be very great south of the line. We hope, however, to have a larger response later in the season. In order that the soldiers who will be released for thirty days furlough may at once have places to go to, blank application forms have been sent all over the province, and these may now be had from the secretary of any local branch of the Manitoba Grain Growers' Association, any railway station agent, or from the Manitoba Immigration and Colonization Office, 430 Main St., Winnipeg.

This Department will have other announcements to make later in regard to the labor situation, but in the meantime I wish to urge every farmer in Manitoba to take heart and seize the opportunity. Last year we had a big "Patriotism and Production" campaign, and production was stimulated as never before. In my humble opinion, all the reasons for a vigorous farming programme that made their appeal one year ago are multiplied many times this season, although rather less is being said about it.

I want to see every Manitoba farmer reach 100 per cent efficiency in his farming operations this year. I know well enough that some men are asking very high wages, and I do not wish to appear to be encouraging in unduly high rates, but I would rather see every man at work in Manitoba even if the wages were a little too high, than to know that we had some idle land and idle men, simply because there was a little difference between the farmer and the man as to what the latter should be paid.

I give the farmers of Manitoba credit for knowing how to farm well; yet nobody must satisfy himself this year with a good wheat-seeding. I am glad to thing that our Marquis and other rapid ripening varieties of wheat will permit of rather later sowing than with Red Fife; but after all the wheat is sown I hope to see a very heavy sowing of oats, barley, flax and fodder crops. These crops are going to count heavily, in this year's operations, and not only the Empire at large, but Canada herself, will be able to use all our surplus of many of these crops.

In addition, I feel that we should seek as never before to increase the number of good live stock on our farms. I past years far too many heifer calves have

Dominion Cannery Co., Limited  
Bow Park, Bradford, Ont.

Robt. Hanna, Brunner Ont.

Nicholas Roth  
Shakespeare Ont.

Burley Miller  
Port Rowan Ont.

Wm Reid, Princeton Ont.

**Ask these Men if they ever saw better Barns**

FARMERS can now buy better barns than they ever saw before—Steel Truss barns of iron and steel. They can put them up in days with a few helpers, where it used to take weeks and months—and a big gang. They can get rid of the old clumsy wooden frame that filled the inside space with beams and timbers. They can forget half their worries, because Steel Truss Barns are fire-proof, lightning-proof, and weather-proof.

This puts barn building on a modern basis. And we leave it to the men who have built on this plan, to say how it carries out all our claims.

But here is the best part of this big new idea. The Steel Truss barn—the barn you would gladly pay a big price to own—costs less than perishable wood.



**Steel Truss Barns**  
(Patented in Canada and the United States)

These barns are built complete in our factories. We send you a whole barn. There is nothing for you to provide, because we ship everything complete—Steel Trusses, corrugated iron covering, and all the lumber, and there's not a piece of wood in the whole job that one man cannot handle. The Steel Trusses come ready to put in place. Doors are fitted with all the hardware, and are ready to hang. Bird-proof track is supplied. Windows are of metal and wired-glass, and are built into the sheets of corrugated iron. They are as easy to put in place as any other sheet of iron.

To land a barn on your farm in such shape as this is going to save you many a dollar in labor, and an endless amount of time and trouble. And, remember, no wood shows anywhere on this barn. Once a Steel Truss Barn is built, there is no cost for repairs—no paint bills, no rotting sills or shingles. Figure that saving when you think about your new barn.

Eight factories are ready to send you one of these barns any size you want—and the very day your order reaches us. We know that men will want to know a lot about this great new barn idea, and we are ready to answer questions and send out full information explaining the whole thing clearly. Do not hesitate to write us about it. Tear out the coupon and mail it to-day.

**The Metal Shingle & Siding**  
COMPANY OF MANITOBA, LIMITED  
Winnipeg, Manitoba  
HEAD OFFICE - PRESTON, ONT.  
Associated with: A. B. ORMSBY & Co., Limited (Preston & Co., Limited) (Saskatoon) Consolidated Factories at: Toronto, Montreal, Regina, Calgary, Winnipeg, Edmonton

**COUPON**  
To The Metal Shingle & Siding Co., Ltd.  
WINNIPEG - MAN.  
Send me full information about Steel Truss Barns advertised in The Canadian Thresherman and Farmer

**Also Practical Barn Framers and Builders Wanted as Agents**

been slaughtered for veal, and ewe lambs have been butchered. At present the live stock supply of Europe is being depleted, and if we in Canada are wise we will seek now to build up our herds and flocks, because there should be a great demand for breeding animals of many kinds for years to come.

I have never been very much addicted to giving advice, but I feel that a word ought to be added about economy. The farmer has the best right of anyone to a goodly measure of luxury, but just at this time we should all practice every reasonable economy. I would rather see those who have money to spare investing it in the next Dominion war issue than in things that are not necessary. This is a time for strenuous work, wisely applied, economy of means and that form of patriotism in soil and the efficiency of our agricultural effort can so happily be blended.

Yours truly,

V. Winkler,

Minister of Agriculture and Immigration.

**Trees Increase Crops**

Trees will actually increase the yields of crops. This was determined by an investigation in Minnesota, Iowa, Nebraska, and Kansas. It was found that one-fifth of the farm could be in trees without reducing the yield. That is, trees in protecting the crops increased the crops enough to make up for the space occupied by the trees. From this it is plain that the resulting trees would not cost anything except the cost of the planting and care. This same thing has been found to be the case in Europe. As a result the general plan there is to have one-third of the land area in trees. And the reason is that this is the

way that the greatest returns are secured.

If one-fifth of the area in Minnesota, Iowa, Kansas and North Dakota can be in trees without reducing the yield of the crops, perhaps even a greater proportion of the land in Western Canada could be in trees without reducing the yields.

The planting of trees would do much to make our western prairies less inhospitable and more home-like. The trees would also reduce the effects of winds and especially of hot winds. The spreading of every weed seed would be lessened. The light soil not blow and the snow would quietly settle where it fell.

**Turn Waste to Profit**

From Dairy Division, Ottawa

Recently a proprietor of a large modern business in a thriving city was heard to remark "my twelve months' trade shows, after allowing myself a low weekly income, not one cent of profit, on all the capital, risk and worry." He distinguishes closely between income and profit for the year.

Does the average dairyman consider his farm business in the same light, each department of its many activities, grain, poultry, lumber, pork, hay, milk! Further does he distinguish between income and profit when dealing with the herd? If (and much depends on that "if") each cow

makes a good profit he is indeed well off. Even if each cow is responsible for a good income, things are not too bad. If some of your cows waste good feed because they are not possessed of ability to make milk economically, find it out; turn waste to profit. Make the cows keep you, that is their job; you need profit on the feed, profit to pay for your investment of capital; risk and worry, the same as any merchant. A letter to the Dairy Commissioner, Ottawa, will bring you free of charge milk record forms, either daily or three days per month, feed records, and a herd record book. When you note down total production and closely estimate cost of feed by occasional weigh-

ings, you arrive at individual profit. Make each cow pay a good profit.

The Jew pedlar rapped timidly at the kitchen door. Mrs. Kelly, angry at being interrupted in her washing, flung open the door and glowered at him.

"Did you wish to see me?" she demanded, in threatening tones.

The pedlar backed off the steps. "Well, if I did," he assured her, with an apologetic grin, "I got my wish, dank you."

Every day which we omit, obscures some truth which we should have known.

—Ruskin.

**The Cockshutt Scrub Breaker**

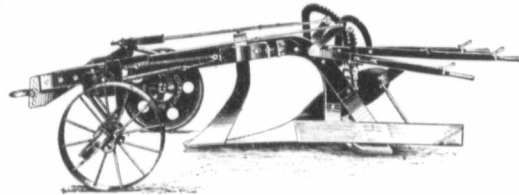

For use with Tractors to clear your scrub land. A giant for strength. It tackles the heaviest scrub that high power tractors can work in. It gets results in one season that might easily take three. Turns a furrow 24 inches wide.

**It Cuts Out the Man=Power=Waste in Clearing Land**

One of the most thankless and most expensive jobs the Western farmer tackles is the clearing of scrub land. Here's where the Cockshutt Engine Scrub Breaker comes in with its powerful work that buries saplings, scrub, small stumps, etc., as though they were straw.

It's an all-steel extra heavy plow, with extra clearance between furrow wheel and share to allow trash to pass. The beams are carefully forged and strongly braced against pulling strain. No handles are used—powerful, easily operated levers, equipped with helper springs, control its operation. Heavy steel coulter is exceptionally strong and rigid, and provision is made for hitching one plow behind the other.

It cuts the cost of clearing land away down---it's more than ever useful where labor is getting scarce. Send to-day for new folder on ENGINE SCRUB BREAKERS, ENGINE DISC or ENGINE MOLDBOARD PLOWS.

**Cockshutt Plow Co. Limited**

WINNIPEG REGINA CALGARY SASKATOON

**Cast Iron Breakages Welded**

We can save you many dollars—not to speak of loss of time and endless vexation—if you will send us all your metal breakages. We can do any repair job that can be welded by the Oxy-Acetylene process in Cast Iron, Steel, Bronze, Malleable Iron, Cast Steel, Copper, Aluminum.

WE OWN AND OPERATE THE

**Oldest and Largest Oxy-Acetylene Welding Plant in the West**

Do not hesitate to send us your Broken Cylinders, Cylinder Heads, Connecting Rods, Crank Shafts, Engine Beds, Bull Pinions, etc. We will return them as good as new, and stronger, where mended, at a great saving. We do not attempt to repair certain castings on which a saving cannot be effected. Send your inquiry now. Do not wait until spring before you have your work done. We will be pleased to give you figures on any work before sending to us.

ENTRUST US WITH YOUR WORK—SATISFACTION POSITIVELY GUARANTEED. ALL INQUIRIES PROMPTLY AND CHEERFULLY ANSWERED BY MAIL.

**Manitoba Welding and Mfg. Co.**

58 Princess Street WINNIPEG (Established in 1911)



**IS YOUR WAGON LOPSIDED?**

Have worn axles made the wheels all out of gear? You could have prevented that condition—and you can still help it with

**MICA AXLE GREASE**

The mica does it. It fills the worn spots of the axle. Won't gum. Kills friction.

At Dealers Everywhere

The Imperial Oil Company Limited

BRANCHES IN ALL CITIES

# Get All Your Hay Profit

ONCE more it is time to prepare for haying. Are your mowers, rakes, side delivery rakes and hay loaders in good condition, ready to get in the whole crop and make money for you in the hay fields? If not, what does your equipment need to make it ready — repairs or new machine?

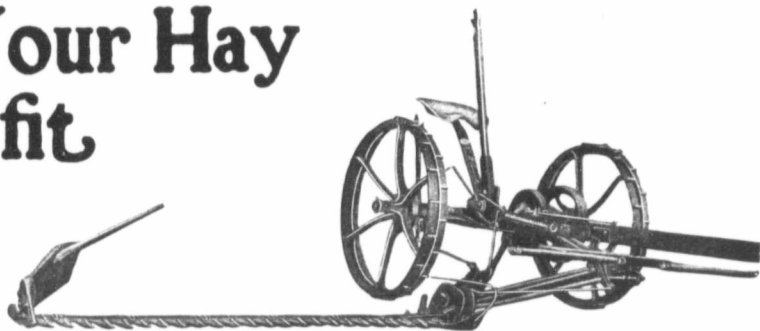

Get your repair order in early and specify genuine DEERING OR McCORMICK repairs for your DEERING OR McCORMICK machines. These repairs are exactly the same as new pieces, made of the same material, from the same pattern. Use them if you want your machines to work like new.

If you need new machines, see the DEERING OR McCORMICK local agent before you buy. You know these names and their reputation. Step in and see the mowers that cut clean in all kinds of fields and crops. Ask the agent to show you the new all steel side delivery rakes and the all steel hay loaders that go with the DEERING and the McCORMICK line.

DEERING and McCORMICK machines, this year, are better than ever before. Don't buy until you have seen them, or have received full information from us. Write us at the nearest branch house.

## International Harvester Company of Canada, Ltd.

### BRANCH HOUSES:

At Brandon, Calgary, Edmonton, Estevan, Hamilton, Lethbridge, London, Montreal, N. Battleford, Ottawa, Quebec, Regina, Saskatoon, St. John, Winnipeg, Yorkton

DEAR Billy:  
Yes, we took your advice and purchased a machine last month. It is a dandy, runs with a nice soft musical hum and takes us down to the village and back in one half-hour, just two hours less than old Frank and Dorothy needed for the same trip. You remember how I was prejudiced against the motors last year, Billy? They used to drive up behind me with those snarly horns which sort of swear at you between their teeth and seem to say, "Get out of the way, you lobster." I hated those horns. We have one of the same kind on our car. It's a mighty efficient horn.

I never used to envy the motorists that ran down past our farm. Their women folks never looked comfortable in the back seat, the wind blowing their mouths full of hair as they gazed down the road with their eyes blinking and their jaws set. Ma says she likes it; however she misses the horse hairs on her Sunday suit when we go down to the meeting house and it doesn't take her all day to dust off her skirt. Yes, Ma likes the car and expects to learn to drive it herself.

You know, Billy, I have been using our old plow team for family driving long enough. Many a time on Sunday I have hitched them to the survey after a hard

## Uncle Abe Buys An Automobile

(A letter from Uncle "Abe" to "Billy," telling him of the Experience with the New Automobile)  
By R. G. KIRKBY

week of work in the field and I have driven them down to the village church feeling so ashamed of myself I knew I ought to have walked or stayed at home because Frank and Dorothy had earned a big holiday, but some way we wanted to get there and the horses had to stand for it. Well, the crops were pretty good this year, wheat ran ten bushels to the acre more than I expected and Ma sug-

gested that we buy a nice little driving horse and a new buggy. We figured out the whole deal, horse two hundred dollars, buggy one hundred dollars, and then began thinking about a new harness. I had never figured on owning an automobile as long as I lived, they seemed like a luxury, and you know that Ma and I have dreaded luxuries like the devil and poison. After losing two nights' sleep

thinking about it, we decided to buy a little car. It has only eaten about three dollars' worth of gasoline since I began keeping track last week and it has been doing a lot of business without any currying or hay-pitching to be loitering was either morning or night.

Why, yesterday I laid back the top and folded it according to directions and then we had a nice big back seat like a delivery wagon. I just loaded up those three chicken crates with the old hen, that we had been keeping two weeks too long for want of time to haul them to town, and in half an hour after catching them with the hen crook, they were down to the express office and by next week there will be a nice little check from the commission man down to the city.

Last week the binder broke while we were busy in the field, our hired man was a bit careless, but I cranked up and drove down to the blacksmith shop and in less than two hours we were using that binder again, it was a fine day, too, and we can't afford losing much time when good weather happens to come around for a brief spell.

You know, Billy, business is business, and the auto is paying its way on this farm. Sometimes I used to get sick of business and wish I was down to the city where



Tommy (trying to get a light): "Confound it! These blinkin' French matches 'll be the death o' me!"

the folks spend their hard earned money for experience and get them. Well, I wished that way before the auto came. Now we have brought the old city right down by the front steps. One turn around the drive from the carriage shed. Ma, she jumps in beside me on the front seat, just a nice bit of fresh air from over the clover fields and we are slipping along the city streets ready to stop along the way and visit with our friends. After the visit we crank up and get home in plenty of time to take a good eight hours in bed before the morning chores.

They held a farmers' meeting over to John Adams' three days after I bought the car. Ma said, "Stay at home, you don't know enough about running the thing." I said, "No, I will squeeze one pedal with my foot and if it don't work I'll try another." Then she was killed sure but I was just fooling her. The blamed machine works right or it stalls dead in the road so you either steer and keep moving or you get fussed and stop. Perfectly safe either way you do it. Well, I picked up Lem Williams and Joe Hamilton and we drove over to the meeting. Lem had been pretty sore ever since I beat him for supervisor but he warmed up in the back seat of that car and said he guessed I was doing pretty well and he would support me when re-election time came 'round. The little car certainly helped fix things up right with Lem. A good cigar used to be my favorite method of loosening up an enemy but the little car now gives them a lift along the road occasionally and beats a stick of tobacco for making folks feel good.

They say automobiles are an expense with gas going up and tires bursting down but the little bus is helping me to earn more money on the farm, at least, it's keeping me on the job earning as much as I used to, and I was getting ready to leave the place. If I'd left I never would have earned a red cent any other place; a farmer can't get onto the ropes in the city after he gets my age.

I always used to worry about a gasoline engine. I didn't know why they went when they went and never knew why they stopped when they stopped. I have been studying the instruction book every day during the last three weeks and I find that the makers of the bus knew enough to put it together right so I haven't altered it any. They advise oiling so I oil and every grease cup gets stuffed full whenever we get ready to go. When our little car backs out of the old red carriage shed, she is greased to slip along nicely and she slips. We haven't had any

# RENNIES SEEDS

**EVERYTHING NEW  
FRESH—PURE  
RELIABLE**

*Ask your dealer or write*  
**RENNIE'S — WINNIPEG**

ALSO AT  
**TORONTO MONTREAL VANCOUVER**

**TICKETS EVERYWHERE  
EAST OR WEST ~ NORTH OR SOUTH**

*Canadian Northern Railway System*  
**OTTAWA, TORONTO, WINNIPEG & VANCOUVER**

*Electric Lighted Trains—Observation Cars in Mountains*  
**Via: JASPER PARK AND MOUNT ROBSON**  
HIGHEST PEAK IN CANADIAN ROCKIES

WRITE: **ROBERT CREELMAN—GENERAL PASSENGER AGENT, WINNIPEG.**

## COAST TO COAST

trouble yet and she runs smoother every day.

Billy, my boy, your old uncle don't blame you for going to the city; he used to want to go himself, that is, up to three weeks ago. We used to feel isolated sometimes, Ma and I, especially in the evening when the church bells rang faintly across the marsh over beyond Aker's woods and the old horses were too fagged to make it a decent act to hitch them up. And then I was tired, too, on those nights and it was no small job to take all of that trouble even for the meeting, especially after finishing a full day in the field and looking forward to the next day which seemed bigger and longer. Now we crank up the little car and then we go and soon we get there and when we are ready to come home, we come, and the whole event isn't any more trouble than visiting your neighbor a couple of miles down the avenue in the city.

You know, Billy, that I used to fairly cuss these city fellows who came rambling across the country in their cars, looking so fresh and sort of aristocratic, but I have decided that they are just like Ma and me, out for a airing and trying to forget some of the pesky

troubles that arise every day that a man really tries to make something of himself and his business. I forgive the blond haired fellow that killed my pig last year and will forget about the old speckled rooster which was all messed up one Sunday afternoon down the road along the pear orchard.

Billy, the car has made a new man of me, it seems like something alive and it minds better than any old horse we ever had on the place. We are getting out and seeing the world now, Billy. It is a much better place than we thought it was; just our township has a lot of good things that I never dreamed of and we have visited friends that I had nearly forgotten. Come and see us during your vacation this year. The old horses will not bore you, and all ready for the twist of the crank the little car will be waiting at the station ready to slide along with that friendly hum which will carry us out to Ma and the old place again.

As ever, Uncle Abe.

The good dairy farmer is never out of a job and that's a thing that thousands of people in the city would be mighty glad to boast of.

### Learn to Write

Short Stories and Photo-plays at home in spare hours. Our Courses are thorough and practical. You earn while you learn. We market your product. Ours is an all Canadian School. Our instructors are Canadian authors well known to you. Write for our Preliminary Test Examination—or, better still, send us something you have written, for free criticism.

**The Arts & Letters School**  
1 East Adelaide Street  
**TORONTO, Ontario**

**HER NEW PUMP IS A MYERS**



The housewife can perform her daily tasks with one-half the effort, if she has modern labor saving conveniences. A MYERS HOUSE PUMP will bring water to the kitchen and save her many steps. These pumps operate easier than others on account of the PATENTED COG GEAR HEAD. Send your name on a postal and ask for circular showing Myers House Pumps in actual colors.  
**F. E. Myers, Bro. Ashland, Ohio**  
Ashland Pump and Hay Tool Works

W  
a sk  
very  
the  
heav  
geth  
our  
stone  
jobs  
posit  
rocki  
out c  
vibra  
gover  
terfer  
speed  
the s  
the m  
explos  
irregu  
come  
frame  
to it.  
een in  
gine si  
in dia  
three j  
in leng  
fastene  
fourths  
inches  
spacing  
behind  
skids.  
then b  
with o  
runners  
ends.  
through  
ners to  
which t  
from pl  
ward o  
ence th  
running  
is somev  
The f  
in the  
been and  
difficult  
line engi  
If the cy  
are cleane  
very little  
it is bett  
formation  
possible.  
covered t  
drops of  
tion char  
was runn  
ment in  
engine at  
examinati  
most of  
peared. V  
was that  
bining wi  
formed a v  
burned, an  
carbon wa  
the same ti  
power of th  
There is

## Gasoline Engine Helps

By W. H. UNDERWOOD

We find the available power of a skidded gasoline engine can be very much increased by bolting the engine skid securely to heavier runners well framed together. Until recently one of our engines has been set on a stoneboat in using it for different jobs in different places. In this position it always bothered about rocking, jumping and working out of line with the belt. This vibration of the engine jarred the governor latch loose and thus interfered with the uniformity of speed. It likewise interrupted the steady flow of gasoline into the mixer, and in consequence the explosions were intermittent and irregular in strength. To overcome these difficulties we built a framework and bolted the engine to it. We took two logs eighteen inches longer than the engine skids and about eight inches in diameter and into these joined three pieces of 4x4 about 3½ feet in length. These cross ties were fastened to the runners by three-fourths inch wood screws seven inches long, and at a proper spacing to fit just in front of or behind the cross ties on the engine skids. The engine skids were then bolted to the 4x4 pieces with one-half inch bolts. The runners were rounded at both ends. Two-inch slots were cut through each end of both runners to admit a log chain with which the engine can be drawn from place to place, either forward or backward. The difference this device makes in the running and power of the engine is somewhat surprising.

The formation of carbon within the combustion chamber has been and still is one of the greatest difficulties with which the gasoline engine operator has to contend. If the cylinder and valve passages are cleaned out at regular intervals, very little time is actually lost, but it is better to try to prevent the formation of the carbon as much as possible. Not long since we discovered that by squirting a few drops of water into the combustion chamber while the engine was running a marked improvement in the performance of the engine at once took place, and on examination it was found that most of the carbon has disappeared. What actually happened was that the water-vapor combining with the hot carbon—formed a water gas, which readily burned, and in this way the excess carbon was consumed, adding at the same time a little more to the power of the engine.

There is no doubt that with

the lower grades of gasoline the use of water when properly applied, is beneficial to the running and power of the engine, but in the first place the operator should see to it that the gasoline becomes properly vaporized before reaching the cylinder by allowing a sufficient quantity of warm air to carry with it just enough fuel to make a proper explosive mixture, as in this lies the secret of complete combustion, carbon being that part of the fuel which has not become vaporized.

Extreme care should be taken in the selection of a good lubricating oil, as the ideal oil must have the correct lubricating body to enable it to withstand a high temperature without losing its lubricating qualities. Any oil that will not do this will cause a deposit of carbon and increase friction losses.

Sometimes a cylinder gets rather badly scored with a broken piston ring or a piece of grit, and as reboring is a somewhat lengthy and expensive job, powdered graphite mixed with the lubricating oil, in the proportion of one tablespoonful of graphite to one gallon of oil and used in the ordinary way, will soon fill up all the grooves and irregularities in the metal and place a smooth frictionless veneer over the entire surface of the cylinder, thereby increasing compression and incidentally the power of the engine. Powdered graphite when mixed with oil and grease is also a valuable aid in lubricating chains and gears.

When replacing the cylinder gear some operators have considerable trouble in preventing the asbestos packing from blowing out, and as this packing must be made both water and gas tight, it sometimes requires several attempts and a good deal of patience before a successful joint is made. The trouble is caused by adjacent faces becoming warped, either through undue heating of the cylinder or a lack of uniformity in the casting, which sets up internal stresses and is entirely beyond the control of the operator. One of the best packings to use in a case of this kind is made from very soft, thin sheet copper in conjunction with the ordinary wire reinforced, woven asbestos packing. The asbestos packing is carefully cut to fit in the ordinary way, but the copper ring must be cut so as to project about a fourth of an inch on the outside as well as on the inside of the asbestos gasket. These projecting edges are then carefully turned up and

## Safety First

Should be your guide in buying a tractor regardless of the size required.

Minneapolis Tractors are built, from the raw material up, in our own large modern equipped plant, in our own painstaking way and backed by the Minneapolis Reputation for building.

### Honest Machinery at Honest Prices

Thousands of customers testify to the goodness of Minneapolis Service and the satisfactory results obtained by using Minneapolis Machinery.

### Price Last

Our prices are consistent when Good Service—Dependable Machinery and Reliability is considered.

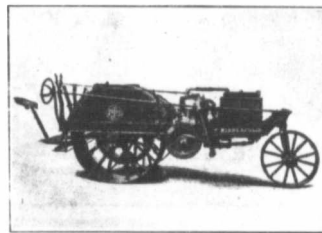

15 H. P. 4 Cylinder—Vertical

Cylinders 4½ x 7  
Motor Speed 750 R.P.M.  
Two Speeds Forward  
Drivers 56 inches High  
Length over all 14 ft.  
Width over all 6 ft  
Approximate weight  
5600 lbs.

Cylinders 5½ x 7  
Motor Speed 650 R.P.M.  
Two Speeds Forward  
Drivers 62 inches High  
Length over all 13 ft.  
11 inches  
Width over all 8 ft.  
Approximate weight  
12000 lbs.

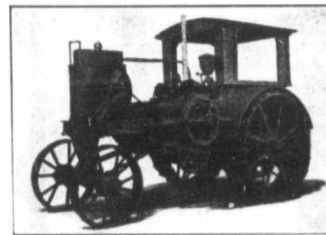

20 H. P. 4 Cylinder—Horizontal

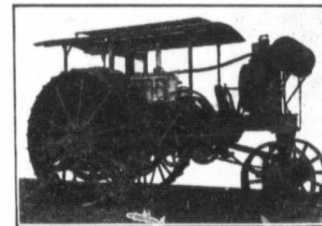

25 H. P. 4 Cylinder—Vertical

Cylinders 6 x 8  
Motor Speed 550 R.P.M.  
Road Speed 2½ miles per hour  
Drivers 85 inches High  
All Steel Gears  
Approximate weight  
17000 lbs.

Cylinders 7½ x 9  
Motor Speed 500 R.P.M.  
Two Speeds Forward  
Drivers 85 inches High  
Length over all 17 ft. 2 in.  
Width overall 9 ft.  
Approximate weight  
22500 lbs.

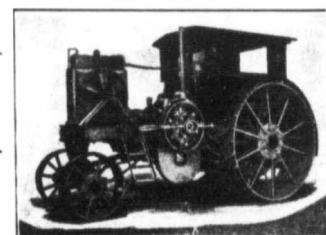

40 H. P. 4 Cylinder—Horizontal

### Automatic Power Lift Plows suitable for any tractor

CATALOG AND "SATISFACTION" BOOKLETS FREE. ADDRESS

**The Minneapolis Threshing Machine Co.**  
"THE GREAT MINNEAPOLIS LINE"  
HOPKINS (West Minneapolis) MINNESOTA, U.S.A.  
Branches: ; WINNIPEG; ; REGINA;

ite

lays

and you  
lect.  
ool.  
dian

Test  
still,  
ave

hool

ario

MP

IS

CGG

Incor  
TERS  
er to  
stap.  
stems  
COG

d ask  
house

Ohio

over both inner and outer edges of the asbestos packing, and when completed, placed in position.

One should see that all the nuts are screwed up tightly, and after the engine is started and begins to warm up go over every nut again, so as to make sure that they are set as snugly as possible. It is important that this gasket should be carefully marked when removing the cylinder head at any time, so that it can be replaced in the correct position without any trouble. The sheet copper used must be soft and handled as little as possible, as handling has a tendency to harden and stiffen it. This makes an indestructible gasket, which cannot be blown out. I know of a number of cases where it has been successfully used as a last resort.

There are a large variety of switches at present on the market, but the knife type seems to be invariably used on all stationary engines, it being simple and efficient. The hinge should be tightened up when necessary, and the jaw fits snugly to the blade. The terminals, or screws, must fit tight, as the current cannot pass along the circuit unless there is close contact at these points. No matter what kind of switch is on the engine, it is important to see that it is screwed down tight and that all electrical joints are kept both clean and tight at all times.

Every one who has had much experience in using a gasoline engine knows that it gives the best results when heated up to the point at which water boils. We like to keep the cylinders of our engines as hot as possible. This heat is necessary to completely vaporize the fuel and to obtain all the energy from it. In hopper-cooled engines the water is kept at the boiling point, but where a rotary pump is used to circulate the water the engine is usually kept cooler than it ought to be. In this case, if there is no stop valve in the suction pipe, it will certainly pay to have one put in so as to restrict the quantity of water flowing through the cylinder jacket and thereby raise the temperature.

An engine which refuses to run is the most wrath-provoking, satanic contrivance ever thrust upon long suffering man, and the difference in price between good and passable will look exceedingly small to the owner after an hour's vain turning of the fly wheel. An hour's search and three minutes "fixing" is a gasoline engine proverb. So if the engine refuses to start when everything seems normal, there is a cause which will be found much sooner by a cool headed, reasoning search than by "flying to pieces" and abusing gasoline engines in general. An observant engine owner soon

# Pull Stumps The Easy, Practical Way

Clear your land the KIRSTIN way—the quick, easy, sensible, economical way—the way that has proven practical under all conditions. One man handles and operates

the KIRSTIN—NO HORSES REQUIRED. And yet it is easier for a man to use the KIRSTIN—it is LESS and EASIER WORK than with any other Puller or by any other method. The improved double leverage KIRSTIN, the new short lever model, stands the extreme tests of the very hardest stump pulling. The KIRSTIN's wonderful compound leverage principle makes any man master of the tough stumps anywhere. In addition to its practically unlimited power, the KIRSTIN

With a KIRSTIN you can easily pull stumps 1-1/2 inches in diameter, keep your hands busy dragging them away



## Changes Speed While Pulling a Stump

No other stump puller at any price contains a similar device. With other machines you keep pulling at the same rate of speed even after the stump has broken loose and the hard pull is over. This is a big waste of time that the KIRSTIN Multiple Speed-Changing feature entirely overcomes.

The Quick-Detachable connections also mean a big saving of time. Furthermore, with the KIRSTIN you can

## Clear Over An Acre From One Anchor

No time lost in having to re-set machine for every stump—no unwinding cables from a heavy drum—no driving round and round—no wasted time or effort at all. Just a steady, easy, back-and-forth movement of the KIRSTIN lever brings stumps out quick and easy. Small trees, hedges, brush, etc., can be pulled in bunches. The KIRSTIN gives you unlimited power. It also has surplus strength in every part—and the right speed for every need. If you have any stumps on your farm

## You Need a KIRSTIN

Why the KIRSTIN? Because the KIRSTIN is the simplest, most practical, most efficient land clearing device ever invented. Lowest first cost—lowest in cost of operation. It weighs much less than any other, is a great deal stronger, and is covered by

## The KIRSTIN Iron-Clad Guarantee

You cannot afford to start to clear your land before you get the KIRSTIN Catalogue. This will be sent you FREE and contains facts about the KIRSTIN Puller, the KIRSTIN Service Bureau and other invaluable land clearing information. We'll also send you ABSOLUTE PROOF that the KIRSTIN is and does all we claim. Try a KIRSTIN on your land—prove its value to yourself. Write today—your first order.

Agents Wanted.

**A. J. KIRSTIN CANADIAN CO.**  
6101 Dennis Street SAULT STE. MARIE, Ont.  
MADE IN CANADA

**CHEW STAG TOBACCO**  
*"Ever-lasting by Good"*

knows the individuality of his engine. All its clicks and whirrs become part of a well ordered chorus, so a new noise is at once detected and remedied. If, before this state of grace and familiarity is reached, the engine stalls, make sure that there is gasoline in the tank and that it is being well supplied to the mixer or carburetor.

The most likely ailment, however, is a poor spark. The battery tester should be used to determine whether these are run down. Whether battery or magneto ignition is used, a set of fresh batteries should be kept as an insurance against stoppage. If a balky magneto is the trouble, about all that can be done is to clean the brushes and commutator and make sure the binding posts are all right. If the trouble is electrical, it may be necessary to employ the services of an expert. Sometimes a friction driven magneto fails to run, due to slippage

on an oily fly wheel. The obvious cure is a clean rag and sandpaper. An examination of the igniter may show that the points fail to come together, or, with a jump spark, that the spark is poorly insulated. After all, with proper current and plugs or igniter in good condition, the engine may still be a stand-patter, so it must now be observed whether or not the charge leaks past the piston with a hissing noise. If so, the piston must be pulled and the snap rings cleaned and made to move freely in their grooves.

There are still several possible reasons for the stalling, for instance, failure of the valves to seat properly. Rotate the fly wheel by hand and if there is little compression listen for the air through the exhaust valve. If it blows through the air inlet pipe, the air valve needs attention. A loose spring will cause the exhaust valve to lift on the intake stroke, thereby destroying suction through

the carburetor and in consequence stalling the engine for lack of gasoline.

The oft repeated statement that any unskilled man can handle a gasoline engine is a fable. He may have a certain routine of actions that will make the engine run, but intelligence and observation are needful for continual success.

A teacher asked her class in spelling to state the difference between the words "results" and "consequences." A bright girl replied:

"Results are what you expect, and consequences are what you get."

Three-year-old Willie, while eating his dinner, was asked if he would have some pudding. "I don't care for any now," said he; "wait until my next appetite."

M 6  
C  
I  
C  
a  
b  
t  
N  
C  
ti  
S  
Boiler  
Car  
Every  
the thres  
tain dai  
men thro  
dian prov  
where the  
Boiler Co  
scale in th  
Hereto:  
able to gi  
factory ir  
fact that  
contain e  
they remo  
or less in  
boiler shel  
The Uni  
of Sagane  
been plain  
several ye  
The Mexi  
This produ  
about 86 p  
found after  
periments  
has a tend  
cracks in th  
down old  
character ar

# CUSHMAN Light Weight ENGINES

4 to 20  
H.P.

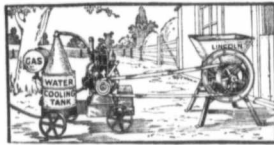

4 to 20  
H.P.

## For All Farm Work

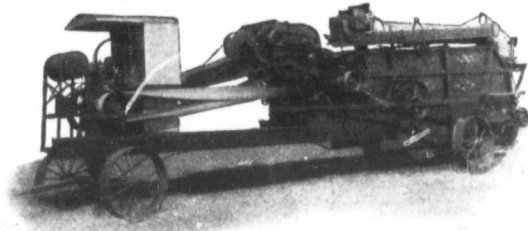

### CUSHMAN COMBINATION THRESHER

8 h.p. with Straw Carrier and Hand Feed. 20 h.p. with Wind Stacker and Self Feed.  
15 h.p. with Wind Stacker and Hand Food. Equipped with the famous Cushman 2-Cylinder Engines.

Cushman 4-Cycle Engines are built to run without trouble and to do things no other engines will do. They represent a great advantage over ordinary stationary engines, in vertical balanced design, material and workmanship. Highly efficient because of light weight, higher speed, reduced friction and lower operating cost.

Cushman Engines are the lightest weight farm engines in the world, yet they are even more steady running, quiet and dependable than most heavy engines, because of Throttle Governor, perfect balance and almost no friction nor vibration.

Direct water circulating pump, preventing overheating, even on all-day run. May be run at any speed desired; speed changed while running. Enclosed Crank Case, gears running in bath of oil. Equipped with Schebler Carburetor and Friction Clutch Pulley. Mounted on Truck or Skid as preferred.

Because of very steady speed, the Cushman makes the best power for Cream Separators or Milking Machine, or for electric lighting outfits.

### 4 H.P. SAVES A TEAM ON THE BINDER

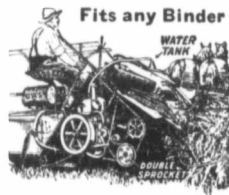

Fits any Binder

The 4 h.p. Cushman is the one practical Binder Engine. Its light weight and steady power permit it to be attached to rear of Binder.

With a Cushman you can cut from 8 to 10 acres more and with less horses. If in heavy or tangled grain, and the sickle chokes, all you need do is to stop the team; the engine clear the sickle. Binder runs the same, whether horses go fast or slow or stop. Binder will wear several years longer, as it is not jerked faster and slower by the horses. Attachments furnished for any binder.

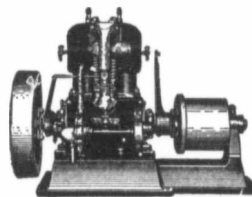

8 H.P. WEIGHS 320 LBS.

Double cylinders mean not only double power, but steadier power. Each cylinder is same bore and stroke as in 4-H.P. Throttle governed and equipped with Schebler Carburetor and Friction Clutch Pulley. A splendid powerful engine for heavier work than 4 H.P. can handle, such as heavy grinding, small threshers, etc., or for any power from 3 to 9 H.P.

Talk with your Dealer about the CUSHMAN LINE or write for FREE CATALOG

## CUSHMAN MOTOR WORKS OF CANADA 286 Princess Street Winnipeg, Man.

Builders of Light Weight Engines for Farm and Binder use. Distributors of Reliable Power Driven Machines, such as Fanning Mills, Grinders, Saws, Cream Separators, Power Washing Machines, etc. Also Bars Door Hangers and Mountaineer Neck Yoke Centres.

### Boiler Compound for Western Canadian Threshermen

Every fall, at the beginning of the threshing season our mails contain daily letters from threshermen throughout the Western Canadian provinces who desire to know where they can obtain a reliable Boiler Compound that will prevent scale in their thresher boilers.

Heretofore we have not been able to give them any really satisfactory information owing to the fact that most Boiler Compounds contain chemicals which, while they remove the scale, have a more or less injurious effect upon the boiler shell and the tubes.

The United States Graphite Co. of Saginaw, Mich., have however been placing upon the market for several years what is known as The Mexican Boiler Graphite. This product is graphitic carbon of about 86 per cent pure. It was found after numerous tests and experiments that graphitic carbon has a tendency to penetrate the cracks in the scale, and thus break down old scale regardless of its character and thickness. Circula-

ting with the water this boiler graphite works into and through the minute opening in the scale and deposits itself on to the inner surfaces of tubes and shell between the metal and the scale with the result that the latter will no longer adhere tenaciously, and may be removed with comparative ease. After a boiler has once been cleaned of its accumulation of old scale, the continuous use of the graphite in the correct quantity will prevent the subsequent formation of that hard scale so difficult to remove since it will form in and with the scale matter and keep same in such loose condition as to permit of its being easily taken out when the boiler is cleaned.

The graphite is introduced as follows: Immediately after cleaning the boiler throw into it about two pounds of the graphite mixed in a pail of warm water, then introduce daily or every other day according to the condition and size of the boiler, from half to a pound. This daily introduction can be made by mixing the graphite in one-half pail of warm water

and draw the mixture into the boiler by means of the injector or by any other method that will insure its getting into the boiler. It should be carefully born in mind that there is graphite and graphite. Some forms of graphite would not do at all. In fact they would be a source of considerable danger. Sometimes graphite of apparently high purity is found to carry a considerable percentage of anthracite coal, coke or other forms of carbon, all of which for that reason are difficult to detect. Such so-called graphites as these instead of loosening the scale actually aid in its formation. Mexican Boiler Graphite however, after years of use has shown that it will remove the scale and by forming a very thin coating over the boiler and tubes will prevent the formation of thresher scale. We can recommend this product to the threshermen of Western Canada. We base our recommendation upon what has been done elsewhere. It has been used very successfully in North Dakota, where the water conditions are

very much the same as they are in the Canadian West. This Mexican Boiler Graphite will be supplied to the threshermen of Western Canada by the Maytag Company, Limited, Winnipeg, to whom all correspondence should be addressed.

### Gopher Problem in the West

Several methods of fighting this pest have been tried, but gophers are rapidly increasing year by year and in dry years the damage caused by them is enormous. The old methods of poisoning have apparently failed to solve the gopher problem. A new method, called SUREDEATH is now offered to the farmers by a chemist who as a boy on a Manitoba farm was elected to take care of the gopher problem when the little rodents were so thick that it was a question who would get the most of the crop, the gopher or the farmer.

For a whole summer the boy fought gophers by every means in his power and came to know a

great deal about the habits of the pest, and its likes and dislikes. He soon found out that the natural and favorite food of the gopher is roots and grasses, that he cuts down the growing grain not for food but for the moisture in the straw, and that gophers never destroyed the crop near sloughs or wet places.

After twelve years on the farm, the gopher student entered the drug business and started experimenting with different poisons, in the light of the experience gleaned on the farm, and was fortunate enough to be associated with one of Western Canada's foremost manufacturing chemists, and now Professor of Pharmacy in a Western University.

The new poison, SURE-DEATH is very powerful, but tasteless, and contains the odors of grasses and roots, at the same time gratifying the animal's craving for moisture.

**BIG BARGAINS IN FARM MACHINERY**

We are pleased to call the attention of our readers to the several announcements of a liquidation sale by Mr. R. S. Ewing in the pages of this issue. Mr. Ewing is the assignee in liquidation of the estate of one of the oldest and most respected farm machinery towns in Western Canada. Nothing more than the stress of war conditions, coming, on top of what was already a period of comparative stagnation has forced this house out of business.

We know the goods advertised, and so does every farmer in the West who has had any interest in buying farm power equipment and implements. They are certainly of the very highest class of machinery made for the farm and in every respect we know the sale at knock-down prices to be a genuine one, and not, as it so often happens, an opportunity to gather together a doubtful job lot into an auction sale room. We feel sure that in any dealings with Mr. Ewing, our readers will find perfect satisfaction and no doubt reap considerable benefit.

**Course of Gas Engineering**

One of the most popular types of short course instruction given by Manitoba Agricultural College is that in steam and gas engineering. The ninth annual short course on these subjects is announced for the latter half of June, the course commencing June 13th and ending July 1st. The College reports that a considerable amount of interest in this year's course is showing itself, and those who have any thought of attending or who are in any way interested in farm engine work should write at once to the College of Winnipeg and secure a copy of the free prospectus outlining the course.

**Course on Better Farming on Wheels**

Starting on Monday 15th June, the Saskatchewan Department of Agriculture, making use of the staff of its University, will commence a five weeks itinerary with the sole purpose of inculcating the principle of better farming and demonstrating by practical illustrations what "better farming" means and what it has already accomplished in increased quality and quantity of agricultural products.



HON. W. R. MOTHERWELL, Minister of Agriculture, Saskatchewan

The Canadian Northern Railway are providing the rolling stock and equipment which will be of the most complete, comfortable and in certain respects luxurious character that has ever been fitted out for anything of the kind. The following will give some idea of the scale on which this fine educational programme has been projected:—

**One Refrigerator Car.**

For ice and supplies.

**Stock Cars**

Two automobile cars, with doors at both ends if possible, for stock and feed, to be fitted up with stalls etc., at Saskatoon under the direction of the college official. Two flat cars, 40 feet long with canopies.

**One Lecture car for Boys and Girls**

A first class coach—large size—two seats removed on each side of aisle at one end and five seats on each side of aisle removed at other end. Back removed from all seats.

**One Lantern Lecture Car**

A first class coach—large size—two seats removed at one end and replaced by 10' platform for lecturer, backs removed from six seats on each side of aisles the end next platform.

**One Poultry Lecture Car**

A first class car, seats removed as in boys and girls car, but platform provided at end where two seats are removed.

**One Field Husbandry Lecture Car**

One first class car—largest size—two seats removed on each side of aisle at one end and platform installed.

**The Feeder that has Brains**

**The Famous Trouble Eliminator**

The feeder that knows more than ignorant or "smart aleck" pitchers, and corrects their errors by delivering the grain to the separator end first in a constant and uniform value, thus insuring well threshed, well separated and well cleaned grain at a much faster rate than is possible with a machine fed by the ordinary feeder that is controlled by the whims of the pitchers. Send for a catalogue of the **Fool-Proof, Trouble-Proof Feeder.** Fill out and mail coupon.

NAME .....

P.O. ....

Dept. "A."

**The Garden City Feeder Co., Limited**

Regina, Sask. or Brandon, Man.

**A Killing Bargain**

The following MUST be converted into Cash within the next few days and I am therefore offering them at LESS than manufacturer's cost.

PORTABLE ENGINES	
22 H.P. single cylinder, portable, Geisler (new)	\$800.00
22 H.P. single cylinder, portable, Geisler (rebuild)	600.00
20 H.P. single cylinder, portable, Geisler (rebuild)	500.00

Also have a couple of 20 to 22 H.P. portables which will rebuild and sell at about \$350.00 each.

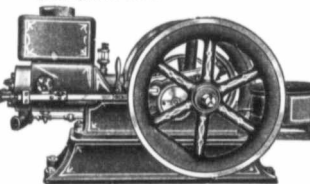

1 1/2 H.P. water cooled (new)	\$ 40.00
1 3/4 H.P. water cooled (new)	51.00
2 1/4 H.P. water cooled (new)	61.00
3 H.P. water cooled (new)	81.00
4 H.P. water cooled (new)	122.00
6 H.P. water cooled (new)	198.00

FOR CASH ONLY

**R. S. Ewing**  
ASSIGNEE  
200 Union Trust Building  
WINNIPEG

SHIP YOUR  
**FURS AND HIDES**  
TO **McMILLAN FUR & WOOL CO.**  
WINNIPEG, MANITOBA  
Write for Circular

Everybody goes vacationing in the summertime now-a-days—housekeepers and homemakers: women young and old. Why not spend your holidays this year touring around in an automobile? You can win a splendid car FREE by entering our **Wheat Estimating Contest** now. Turn to page 5 for particulars.

Ma  
One  
A  
Five  
floor  
10" h  
Fir  
seats  
side  
on ea  
other  
along  
to the  
One  
One  
remov  
Also  
The  
gramm  
the itin  
Insp  
Live  
Field  
No. 2).  
or Bu  
(Car No.  
Inspec  
bulletins  
A  
Inspect  
2.30.  
A. M. SHAW  
Husbandry  
Live sto  
(Car No. 5  
Building  
(Car No. 4  
Inspectio  
bulletins ar



**One Household Science Lecture Car**

A first class car. Large size. Five seats removed on each side of aisle in centre of car and entire floor space covered with a platform 10" high.

**One Nursery Car**

First or second class car. All seats removed, except one on each side of aisle at one end and five on each side of the aisle at the other end. A sand box 3' by 12' along one side and coming close up to the seats.

**One Mechanical Exhibits Car**

One large baggage car—heater removed.

Also sleeper, diner and crew car. The following is a daily programme to be followed each day of the itinerary.—

**Men's Programme Morning Meeting**

Inspection of Train.  
Live Stock Lectures (outside).  
Field Husbandry Lectures (Car No. 2).

**Women's Programme Morning Meeting**

Inspection of Train.  
Lecture on Dairying (Outside).  
Lecture on Household Science (Car No. 6).



JOHN BRACKEN B.S.A., Prof. of Field Husbandry (Saskatchewan University)

Lecture on Poultry (Car 5).  
Inspection of train, obtaining bulletins, and asking questions.  
Inspection of train, 2 p.m. to 2.30.  
Lecture on Dairying (Outside).

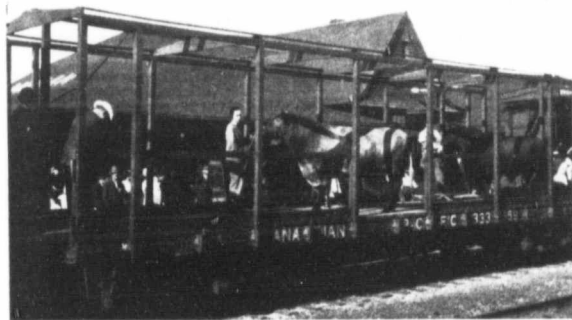

Representative Bulls Used for Demonstration Purposes

or Building Construction etc., (Car No. 3).  
Inspection of train; obtaining bulletins and asking questions.

**Afternoon Meeting**

Inspection of Train, 2 p.m. to 2.30.



A. M. SHAW, B.S.A., Prof. of Animal Husbandry (Saskatchewan University)

Live stock Lectures (Outside). (Car No. 2).  
Building Construction etc., (Car No. 4).  
Inspection of train; obtaining bulletins and asking questions.

**Afternoon Meeting**

Lecture on Household Science, (Car No. 6).  
or Lecture on Poultry, (Car No. 5).

**Boys' and Girls' Programme Morning Meeting**

Inspection of train; obtaining bulletins and asking questions.  
Inspection of train, especially cars Nos. 2, 5 and 6.  
Lecture on Dairying (Outside).  
Illustrated Lectures in Lantern car No. 3.  
Lecture in Boy's and Girl's car No. 1.  
Inspection of mechanical exhibits car No. 4.  
Inspection of train, obtaining bulletins and asking questions.

**Afternoon Meeting**

Inspection of train, especially cars Nos. 2, 5 and 6.  
Lecture on Dairying (Outside).  
Illustrated Lectures in Lantern car No. 3.  
Lecture in Boy's and Girl's car No. 1.  
Inspection of mechanical exhibits car No. 4.  
Inspection of train, obtaining bulletins and asking questions.

**THE NEWMAN CO LIMITED**  
WINNIPEG CANADA

**"DEFIANCE"**  
THE RIGHT  
**Steam Cylinder OIL**

INCREASES THE EFFICIENCY OF YOUR MACHINERY

Adapted for either high or low pressure cylinders. Order in ½ barrels (25 gallons), or barrels (42 gallons) and get the benefit of price—

½ Barrel - - No. 13P602 - - Price \$12.00  
Barrel - - No. 13P603 - - Price \$18.00

Send for our catalogue containing oils and greases for all purposes. It has many other lines of interest to the farmer and thresherman.

Address: Dept. "P."

**PRODUCTION** is largely the work of Nature. **THRIFT** is handling economically what Nature produces. Therefore 1916 conditions demand that you investigate the merits of the

Stewart Sheaf Loader

\* \* \*

**T**HERE are approximately 25,000 threshing outfits in Western Canada. If five men were saved to each outfit (which is the saving effected by the "Stewart" Loader) it would mean that 125,000 fewer men would be required to thresh the 1916 crop.

\* \* \*

We could not supply anywhere near 25,000 Sheaf Loaders for the 1916 trade; in fact we will only build a few, owing to the shortage in materials. It is therefore up to you to get your order in EARLY if you want to be able to meet the labor situation to the best advantage. Write us now while there is time to go into the matter carefully.

The Stewart Sheaf Loader Co. Ltd.

WINNIPEG

The Animal Husbandry Section will be in charge of Professor A. M. Shaw, assisted by Professor N. H. J. Tisdale and P. F. Bredt acting Live Stock Commissioner and other authorities on live stock matters.

The live stock to be carried on the train will include representatives of dairy, beef and dual purpose cattle.—One Clydesdale stallion.—representatives of Yorkshire Berkshire and Tamworth hogs—some range ewes with their progeny of the first and second crossing sired by pure bred rams.

**Field Husbandry Section**

Topics which will be dealt with by the Field Husbandry Lecturer will include:

Forage crops in Saskatchewan. The choice and management of farm crops.

Tillage in relation to crop production.

The control of noxious weeds.

Practices that promote early maturity in grains.

These talks will be illustrated by means of colored charts, photographs and samples of the crops and weeds to be discussed.

Section, on the following subjects:—Farm Layouts, Building Construction, the Use of Concrete on the Farm, Water Supply and other utilities as desired by the audience; also lectures by Professor Smith on Farm Machinery. The Draft

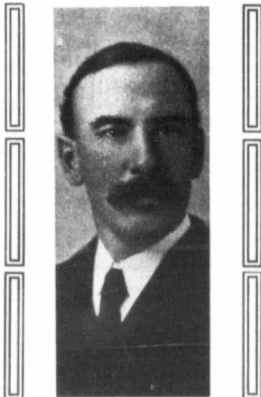

A. R. GREIG, B.Sc., Prof. of Agricultural Engineering (Saskatchewan University)

of Implements, Horse-Power, Ploughing Matches or other features of interest to the farmer.

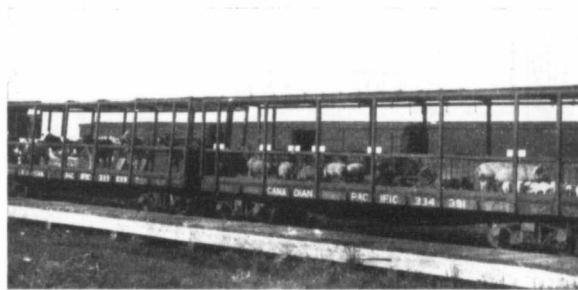

GENERAL STOCK DEMONSTRATION EQUIPMENT

Professor John Bracken will be in charge of the Field Husbandry section. Professor Bracken first represented the Dominion Seed Branch in Manitoba and left that work to accept the position of Superintendent of farms and Institutes for Saskatchewan, later being transferred to the College of Agriculture on its organization.

Hon. W. R. Motherwell, Minister of Agriculture for Saskatchewan, will, it is expected, be with the train throughout its itinerary and will lecture twice daily on subjects such as Forage Crops, Noxious weeds, etc. Mr. Motherwell's knowledge of agriculture and ability as a public speaker are recognised throughout Western Canada.

J. G. Rayner, B.S.A., District Representative of the Saskatchewan Department of Agriculture at North Battleford, H. Saville, B.S.A., and L. E. Kirk, assistants in Field Husbandry will also take part in the programme of the Field Husbandry Section.

**Mechanical Exhibits Section**

Professor A. R. Greig, will be in charge of Mechanical Exhibits

In the Mechanical Exhibits car will be sectional models of farm buildings, a sectional model of steam engine and also of a gasoline engine, a small working model of a pneumatic water supply system, and one portion of the car will be arranged showing complete equipment of a dairy. There will be a line shaft in this car and various machines will be operated. This car will also contain an electric light equipment suitable for a farm; this will be used in lighting the dark car that is being used for lantern slide work and also the mechanical exhibits car.

**Poultry Section**

In charge of Professor R. K. Baker, B. A. In the Poultry Department of the Saskatchewan College of Agriculture, consisting of working models of poultry houses, and appliances for hatching, brooding, rearing, caponising, fattening, killing and marketing poultry; charts and illustrations of the anatomy of the fowl and of standard types and breeds of poultry; sample egg cases, boxes and cartons, egg candling devices, eggs

(Continued on page 70)



**SAVE MONEY**

BY KEEPING THE SCALE OUT OF YOUR BOILER

**U. S. G. CO.'S Mexican Boiler Graphite**

"The Guaranteed Scale Remedy"

is positively guaranteed to soften old hard scale of long standing, so that it may be easily removed, and to prevent further hard formation.

It does this by MECHANICAL—not chemical—action, working equally well in ANY water and under all conditions, making it ideally suited for traction boilers which draw water from different sources every few days. It is far superior to chemicals or chemically-acting compounds, because the former attack and weaken the metal while Mexican Graphite acts on scale only and cannot injure the boiler in any way, shape or form.

The cost is so slight—ONLY A FEW CENTS A DAY—and the saving in fuel and repairs so great in comparison, that no traction operator can well afford to be without it.

**USE THE ONLY GENUINE U. S. G. CO.'S Mexican Boiler Graphite**

Manufactured by The United States Graphite Co., Saginaw, Mich.

**MONEY REFUNDED IF IT DOES NOT PROVE ENTIRELY SATISFACTORY,** and refund will be made without question, upon request.

The U.S.G. Co.'s MEXICAN BOILER GRAPHITE is put up in 50 pound kegs especially for the traction engine, which is sufficient for an average season's run. Write for booklet on "The Care of Traction Engines," to the MAYTAG CO., LIMITED, WINNIPEG, CANADA, who have a large stock on hand at all times and are prepared to fill orders promptly.

(Copyrighted 1916 by the United States Graphite Co.)

**Our Big Free Catalog**

is Bigger and Better than ever. You should have a copy of this wonderful book. It's yours **Free** for the asking. Everything in Furniture, Stoves, Wire, Vehicles, Harness, Washers, Hardware, and practically everything for the home. Get your copy to-day, a postcard will bring it.

**GET YOUR NEW BUGGY EARLY**

Here's the very best in an Auto Seat Buggy. We have but every improvement possible into this Buggy, making it equal to any \$100.00 vehicle offered elsewhere. The wheels are screwed and bolted between each spoke; the gear is our time-tried double reach full iron-rod; the piano body is large and roomy, securely braced and has patent leather dash. The seat is upholstered with genuine leather, extra large and roomy full spring and has high automobile back. Throughout we have given every detail the minutest attention. Painting is the acme of perfection. Don't hesitate to order this buggy on approval. Money returned and all charges if not satisfactory. Price at Winnipeg



**\$69** Complete with Shafts at Winnipeg

EVERY BUGGY WE SELL IS GUARANTEED FOR TWO YEARS

**69.00**



**\$1.50**

Postpaid without Handle. Handle 15c extra

**EXCELLO VACUUM WASHER**

ORDER One on 30 Days' Trial Money Refunded if Not Satisfactory

Washes Tub of Clothes in 3 Minutes.

**Every Housekeeper Deserves One**

The difference between the cost of an Excello Vacuum Washer and other washing machines would buy a new dress and the Excello will do all and more than any washing machine built. Washes, rinses and blues. The only perfect Vacuum Washer made. We ship this to you on 30 days' trial—if unsatisfactory return at our expense. It is shipped by parcel post and our price of \$1.50 is delivered at your station. The Vacuum Washer will last a lifetime and you will be surprised at the amount of work it will turn out. Order is return subject to our 30 days' free trial offer. No. 763. Vacuum Washer post-paid ..... \$1.50

**The FARMERS' SUPPLY Co. 173 Bannatyne Ave. WINNIPEG**

light a dition. In vi metal when ically the ro these u conduct and dri into the ation of well to the u iron "gr ing then

It is es pipe be not allow thus bre path ov may disc

You v that the is anothe Fire Pre cognize t or "Meta protection lightning.

A quot the Mutu ean, Oxf after the Fire Insur

"Every country, year, could wood shin roof, and duce their the entire We will d point out that his int stitution of roof over v

It will b is from a M to their in truth, and t as much as cost of the on the tota

The ordi not difficult ning. A connected ample prote from lightni stop the co inches of should be a path from t into the gro

The vital tion are twc manently mc to secure a between the earth conduc

The point that building and properly ground sho to, or conne

**Lightning Protection on the Farm**

Continued from page 15

light about the most helpless condition of humanity.

In view of the above the use of metal shingles or metal roofing when put together, makes practically a solid sheet of metal over the roof. In connection with these use metal eave troughs and conductor pipes or down spouts and drive the galvanized iron pipe into the ground near the termination of the conductor pipe. It is well to fasten the conductor pipe to the upper end of the galvanized iron "ground" by soldering or wiring them tightly together.

It is essential that the conductor pipe be properly maintained and not allowed to become unjointed, thus breaking up the continuous path over which the lightning may discharge into the ground.

You will note from the above that the Fire Underwriters, which is another name for the National Fire Protective Association, recognize the value of the all-metal or "Metal Clad" buildings as a protection against the effects of lightning.

A quotation from a report of the Mutual Fire Prevention Bureau, Oxford, Michigan, looking after the interest of the Mutual Fire Insurance Companies:

"Every elevator or mill in the country, even if only built this year, could afford to tear off their wood shingle roof and buy metal roof, and siding and thereby reduce their rate enough to pay for the entire charge in a few years. We will do everything we can to point out to the property owner that his interests demand the substitution of iron cladding and iron roof over wood construction."

It will be noted that the above is from a Mutual Bureau and it is to their interest to speak the truth, and to cut down the losses as much as possible because the cost of the insurance depends upon the total loss.

The ordinary farm building is not difficult to protect from lightning. A metallic roof properly connected to the earth affords ample protection to the buildings from lightning. It will not do to stop the conductor within a few inches of the ground. There should be an unbroken metallic path from the ridge of the roof into the ground.

The vital points of the connection are two: first, to reach permanently moist earth and second, to secure a perfect metallic joint between the down spout and the earth conductor.

The point to be emphasized is that buildings covered with metal and properly connected to the ground should not be attached to, or connected with buildings

# Production and Thrift

"CANADA from her abundance can help supply the Empire's needs, and this must be a comforting thought for those upon whom the heavy burden of directing the Empire's affairs has been laid. Gain or no gain the course before the farmers of Canada is as clear as it was last year—they must produce abundantly in order to meet the demands that may be made, and I believe this to be especially true in regard to live stock, the world's supply of which must be particularly affected in this vast struggle. Stress and strain may yet be in store for us all before this tragic conflict is over, but not one of us doubts the issue, and Canadians will do their duty in the highest sense of that great word."—HON. MARTIN BURRELL, Minister of Agriculture.

"MODERN war is made by resources, by money, by foodstuffs, as well as by men and by munitions. While war is our first business, it is the imperative duty of every man in Canada to produce all that he can, to work doubly hard while our soldiers are in the trenches, in order that the resources of the country may not only be conserved, but increased, for the great struggle that lies before us. 'Work and Save' is a good motto for War-time."—SIR THOMAS WHITE, Minister of Finance.

## THE CALL OF EMPIRE COMES AGAIN IN 1916

TO CANADIAN FARMERS, DAIRYMEN, FRUIT GROWERS, GARDENERS

### WHAT IS NEEDED? THESE IN PARTICULAR—

WHEAT, OATS, HAY,  
BEEF, PORK, BACON,  
CHEESE, EGGS, BUTTER, POULTRY,

CANNED FRUITS, FRUIT JAMS,  
SUGAR, HONEY, WOOL, FLAX FIBRE,  
BEANS, PEAS, DRIED VEGETABLES

*We must feed ourselves, feed our soldiers, and help feed the Allies. The need is greater in 1916 than it was in 1915. The difficulties are greater, the task is heavier, the need is more urgent, the call to patriotism is louder—therefore be thrifty and produce to the limit.*

"THE AGRICULTURAL WAR BOOK FOR 1916" is now in the press. To be had from The Publications Branch, Department of Agriculture, Ottawa.

THE GOVERNMENT OF CANADA

2

THE DEPARTMENT OF AGRICULTURE

THE DEPARTMENT OF FINANCE

not protected, otherwise the unprotected building may be struck by lightning and be set afire, and of course the flames will communicate to the contents of the other building. It is important that all connected buildings be similarly protected.

Every insurance company will give a reduction in rates for metal clad properly grounded buildings and this reduction will eventually more than pay for the slight additional cost of the metal covering in the first instance.

It is also well to note that all the authorities unite in stating that the sheet metal should be heavily and thoroughly protected by galvanized coating in order to be an efficient conductor as well as making it proof against corrosion.

With the above facts in mind there is no reason why every farmer should not protect his buildings and stock by the use of metal coverings, whenever a roof

## FORCED TO SELL

The underrated Gasoline Tractors and "Gelsar" Separators (new and rebuilt) must be converted into cash. They are part of the stock of one of the oldest and most respected farm machinery houses in Western Canada, NOW IN LIQUIDATION and will be sacrificed at less than manufacturer's cost.

GASOLINE TRACTORS		GADE ENGINE	
45 H.P. 4 cylinder Tractor (rebuilt).....	\$1,700	6 H.P. air cooled (rebuilt).....	\$115.00
45 H.P. 4 cylinder Tractor (new).....	2,200	BADGER ENGINE	
GELSAR SEPARATORS		14 H.P. Standard stationary (rebuilt).....	
AA Sep., 40x60, complete.....	\$1,000.00	\$150.00	
A Sep., 36x56, complete (new).....	1,064.29	There is Nothing Like These Goods	
C Sep., 30x46 no blower (new).....	597.55	Anywhere at Anywhere Near	
D Sep., 27x59, complete (rebuilt).....	600.00	THE PRICE	
E Sep., 24x32 Straw Car (new).....	351.12		

CASH ONLY—except in case of Tractors and Portables for which reasonable terms will be considered at increased prices.

**R. S. Ewing, Assignee, WINNIPEG** 200 Union Trust Bldg.

has to be replaced or new buildings erected; thus removing the fire menace, as prevention is better than cure, when adequate fire protection is not available.

**QUITE DIFFERENT**  
"I understand your brother is studying with the intention of becoming a veterinary surgeon," said the visitor.  
"Well, he isn't," answered 5-year-old Edna. "He's going to be a horse doctor."

# A Woman's Talk



# To Women

By Lillian Beynon Thomas

## CHILDHOOD

*"Backward, turn backward, O Time, in thy flight,  
Make me a child again, just for to-night."*

"It is a good thing we cannot see ahead," a man said to a group of friends. "Yes, indeed it is," agreed a young girl. "I do not know about that," it was the middle-aged woman who spoke. "I think I would have been happier as a child, if I had known that things would be so much better for when I grew up."

"I don't want time to turn back for me," the business woman said. "I do not believe that childhood is the happiest time. It certainly isn't for many of us. I hate to think of my childhood."

"So do I," said the mother. She pulled her child a little closer. "But it is going to be the happiest time for my kiddies, if I can manage it."

"Children suffer so much from the cruelty of parents," the man with the hair whitening about his temples said. "I remember with anguish yet, some of the tragedies in my young life."

"So do I," said the fat man with a chuckle that was not mirthful. "I will never forget my first suit with long trousers. I had looked forward to that suit with longing and pride. The suit went



The Nations Meet

the time came was all right, but it was spoiled by the fact that my parents bought me a hat with ribbons down the back to wear with it. I protested, and pointed out that other boys were not wearing such hats, but it was no use. They knew it all, and I suffered the most awful social torture while that hat lasted. It was cruel."

"I often think children suffer more than grown people." It was the girl with her hair piled high, who made this remark. She had been a child only a short year or so ago. "It was my—" she caught her breath and added, "but what is the use of thinking about those old days. We are all grown up and having a lovely time. Maybe we would not enjoy life so much now, if we had not suffered."

"I don't want to be a child again, but I had a lovely time." It was the hostess who was speaking. "I like to think of the time when I was at home, before I had any responsibility."

"Yes, and I had a good time. I like to think of it." It was the bachelor who was speaking. "And if I ever have any kids they are going to have the time of their lives when they are with dad."

"Huh!" It was the mother of nine who grunted. "The children of bachelors and old maids are always perfect. Tell me if you think you could raise nine children, each as different from the other as possible, and not make some mistakes. I apologized to my little girl the other day when I thought I had made a mistake by punishing her. She was real motherly and told me not to mind for she was pretty sure that in my place she would have done the same thing."

"Your children are all right if they

will talk to you like that," said the business woman. "But not all mothers are like you. I have thought of starting a campaign for the rights of children. I would like to thrash every grown up person who brings the blush of shame to



Playmates on the Prairie

the cheeks of a child because of childish mistakes. I would like to punish every grown person who refuses to listen to the child's side of the story. I would to—"

"Hush! The children are coming."

## War Widows

A question that is exciting great interest at the present time, is the Salvation Army scheme to take five thousand war widows and their children to the British colonies. The plan of the Army is to take these women and their children to the small towns, find a home for each family, preferably in a house with someone else. The children will thus have an opportunity to go to school, and the mother can leave the small children with whoever lives in the house while she goes out working.

These widows will each have a small pension, and it is the belief of the Army officials that she can earn enough money charring to supplement this income, to such an extent that she and her family can live until the children are old enough to work.

This scheme depends on a number of things. The first thing is a home. Those who know our small towns and villages know that there are very few double houses in the West, and very few houses large enough for two families. But if such a thing can be found, there will be the problem of getting a family that will be willing to share their house with the widow and her children, and caring for the children while the widow is out working.

There may be such families, but they are very scarce. Then, while some people might be willing to give the widow a home now, when everyone is feeling anxious to be patriotic, there will be a time, when that feeling has grown a little cold, and the daily friction of trying to manage with two families in the house will be the most important thing in the world. When that time comes, which it is sure to do, unless the widow has a house of her own, the widow will find herself homeless.

The Salvation Army undertakes to supervise these widows' affairs for four years.

The facts of the case are, that the Salvation Army has not the money to provide for these women for that time, and if the women are for any reason unable to care for their families, the care of them will fall on someone else. The Army is going to try and interest a committee of citizens of the villages where the women are placed, whose business it will be to look after the interests of the widow and her family. There may be many good people who will be willing to undertake such a responsibility, and the widow may be a strong woman who can make her way, and the women of the village may

be glad of her help, and the farmers may be glad to get her children to pick potatoes or do chores, and those of us who live in Canada may conceivably be benefited.

But what of the widow and her children. She is a woman who has given her husband for his country and theirs, and in return, she is not to have any of that country, nor are his children to have any of the country for which their father gave his life. They are to have the privilege of coming to a new country, with an extreme climate, where living is high, and conditions are not such as they understand. They are to have the privilege when they come of doing the dirty, hard char-work of the country. They are to have the privilege of doing the hardest work for the least pay, of any work that is done. They are to be compensated for their suffering by having to bear an unjust portion of the cost of the war.

It seems to me that those women of us, who have an understanding of conditions of life in the West and of life in the Old Land, should put up a strong protest again our own sex bearing such an unjust burden. War costs, but we should all bear the cost, and not ask weak and helpless mothers to shoulder the responsibility of the government. We have shouted to our men to go and fight for their country. Women have been very quick to send letter and white feathers to those they thought should enlist. Let them be just as quick to demand for the widow and children of those who have gone and made the supreme sacrifice, that they be given a home and enough on which to raise their families respectably.

Surely the wives of our soldiers deserve some consideration, and if ever they needed their friends, and familiar surroundings, it is when they have had to look at the vacant chair and realize that never again would they hear the loved voice, never again would the childish voices echo to the call "Daddy." It is at such a time that a mother needs all her friends around her and all the loving sympathy that only those known through years of association can give.

There may be war widows who will wish to bring their families to Canada, that their children may have more chance than they could ever have in the Old Land. If these widows wish to come, not



The First Prairie Cradle

one woman in Canada, but would be glad to give them all the help possible. But let the government give them enough to live on, so that when they come, they can care for their children as they should be cared for. Let them be given every chance to bring their families up properly,

instead of bringing them out here to be hewers of wood and drawers of water for Canadians.

## Widows' Pensions, and the War Widows

Some time ago, I mentioned on this page that Manitoba was the first province to pass an act granting pensions to widows. The idea of this act is to provide enough money to enable a widow with children to keep a home for those children, and stay in that home, and care for the children. All social workers will tell you that it has been found that children of widows who must go out to work, contribute largely to the delinquent class. The mother is out working and so cannot care for the children, and they run wild, and get into trouble.

The women of Manitoba were very proud to get this advanced legislation through. It seemed to them a step in the right direction. It means a recognition by the state of the value of children. We have always heard of that value, but before the state paid more for the production of hogs than for the children. It has seemed to us that any legislation for the purpose of preventing delinquency and crime is an advance. Now the problem is, if these war widows are brought out here, why should they not be given grants just the same as our own widows?



Born in a Wigwam

In fact it seems to me they will have to be given the same grants, after they have lived in the province the stipulated time, or else, we will have to legislate against the widows of soldiers. This would not be fair. Then what are we going to do?

This matter of war widows looks simple, to those who do not know conditions of life in this province. To those of us who do, it looks like a serious matter, and to those who believe that the whole cost of the war should be borne by us all and not chiefly by the widows, it seems criminal.

## Women and the Schools

At the present time there is a great deal of talk about methods of education. People are beginning to realize that our present system is very far from perfect. That fact being once realized everyone at all interested in the problem of education, is busy thinking of the possible and advisable improvements. In the general revolution that is going on, there will doubtless be many false, and even injurious theories advanced, and methods tried. The object of the more thorough educationists will be to advance slowly but surely. The trouble will be that some will be too conservative to advance at all. But with the popular demand so insistent, as at the present time, some advance will be made whether educationists will or no.

The object of those who can see both the need of a change and the danger of going ahead too fast, should be to make at once as thorough a study of the whole matter as possible, and experiment, and experiment and again experiment, and

Continued on page 71

# -top class -bottom price

This car is the result of a definite purpose to supply a definite need with definite finality.

It is built for the man whose purse cannot afford a big expensive car—

For the man whose pride cannot afford an unsightly, little, uncomfortable car—

And it is a very definite success.

Beauty is not necessarily a matter of size.

Neither does size altogether control comfort.

But skill, experience and facilities are required to build a small, beautiful, comfortable, economical car.

In a word, this car required Overland organization.

And here is the small, light car—complete to the last detail.

Its performance is on a par with its beauty, comfort and completeness.

And its price—\$850—is far below any former price for any completely equipped automobile—regardless of appearance or comfort considerations.

A glance at the car impresses you immediately with its beauty and finish.

As you look it over and read its specifications, you realize its absolute completeness.

But you must ride in it to appreciate its comfort.

You must drive it to get the thrill its performance will give you.

You can own one of these cars.

But act promptly—for no car was ever in such demand.

In spite of record productions and advancing prices, there is a shortage of cars.

The demand naturally centers on top class at bottom price—this small light car.

And no other car at anywhere near its price can compare with this one for beauty, performance, comfort, completeness and economy.

Get in touch with the Overland dealer—now.

Catalog on request—please address Dept. 662.

**Willys-Overland, Limited**  
Head Office and Works, West Toronto, Ont.

# Overland

TRADE MARK REG.

# \$850

## Roadster \$825

Model 75 - f.o.b. Toronto.

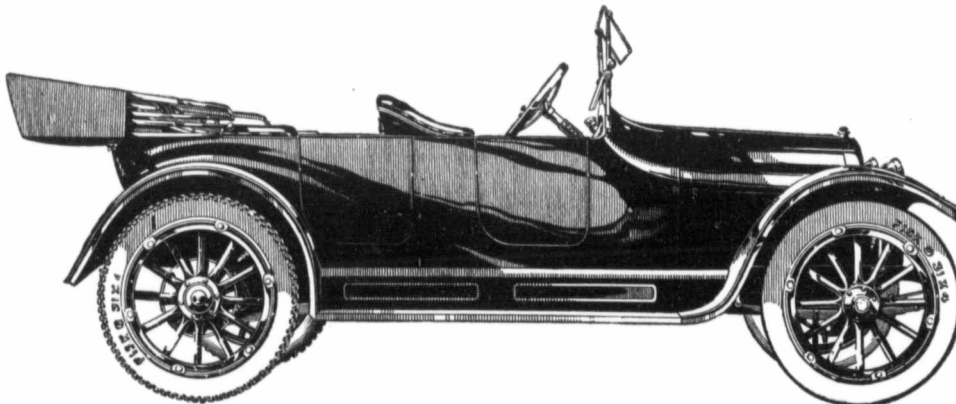

ay, '16  
nas  
t here to be  
rs of water  
the War  
ned on this  
e first pro-  
pensions to  
t is to pro-  
le a widow  
e for those  
home, and  
cial workers  
found that  
t go out to  
the delin-  
out working  
ildren, and  
rouble.  
were very  
legislation  
a step in  
a recom-  
of children.  
value, but  
or the pro-  
children. It  
islation for  
delinquency  
v the prob-  
re brought  
t be given  
in widows?  
  
ll have to  
fter they  
stipulated  
legislate  
rs. This  
t are we  
as simple.  
illions of  
f us who  
7, and to  
e cost of  
and not  
criminal.  
Is  
a great  
lucation.  
that our  
perfect.  
everyone  
f educa-  
tion and  
general  
ere will  
n injur-  
methods  
orough  
slowly  
at some  
nce at  
and so  
y, some  
action-  
e both  
oper of  
o make  
whole  
at. It  
t, and

# OUR YOUNG CONDUCTED BY Cousin Doris. FOLK

## Girls' Cosy Corner

### MOTHER

By Ralph M. Thompson.

Lord, should there ever come a day,  
And such may come to any one,  
When tempted from the right to stray,  
When prompted with the wrong to stray,  
Will me the courage to secede,  
The backbone to refuse to err;  
The might of mind in every deed,  
To think of her—to think of her!

Master, if there should come a year,  
Amid the turmoil and the strife,  
When disinclined to persevere  
For the exalted things of life,  
Grant me the fortitude to stand,  
Above all else, for character;  
The strength of heart, on sea or land,  
To think of her—to think of her!

God, should there ever come a time,  
When in the fight I hope to win,  
My spirit would, from ways sublime,  
Turn at the siren-song of sin,  
Give me the manhood to defy  
The fiercest fury hell may stir;  
The zeal of soul, until I die,  
To think of her—to think of Her!

### My New Year Resolutions.

I see in the farmer's Canadian Thresherman that you are offering a prize for the best essay on New Year resolutions. Allow me to try.

For some time I have been reading one chapter of the Bible every night, and on Sunday I read five chapters. At the New Year I made a resolution that I would continue reading this portion all the time until I had the Bible read right through.

We made a resolution at school to do a kind deed each day. We were always to do one kind deed every day, and as many more as we liked. I am trying my very best each day to do all the kind deeds I can. I have done one each day and some days I have done more. Of course, every day almost I have done some bad things that I know I should not have done, and now I am truly sorry, and I hope God will forgive me for doing them. I hope there are some others who have made this resolution, because I think it is a very good one.

To be kind to animals and not cruel to them is another resolution. To have power over animals is a great thing, but the only real power is that which is gained through kindness.

Now, I think these are all my New Year resolutions, and I hope many of the others will have the same ones, and our influence will spread. I really and truly do want to keep these resolutions.—Yours sincerely,

Marjorie Rankin (aged 10),  
Box 327, Deloraine, Man.

## Our Boy Scouts

**SELF-EDUCATION IN SCOUTING**  
Concentration in Education Can Only Be Obtained When the Work to Be Done Is Suited to the Tastes and Abilities of the Learner.

The natural instinct of the infant is to develop itself by exercises which we call "Play." It has an inherent desire to accomplish; the young child wants to do things and to overcome difficulties to its own satisfaction.

Dr. Montessori has proved that by encouraging a child in its natural desires, instead of instructing it in what you think it ought to do, you can educate it on a much more solid and far-reaching basis. It is only tradition and custom that ordain that education should be a labor, and that as such it is good training for the child in discipline and application.

One of the original objects of Scouting for boys was to break through this tradition and to show that, by giving attractive pursuits to the young,



A Brave Scout

Patrol Leader Melbourne Crawford, of the 9th Winnipeg Troop, saved the life of Scout V. Spitzer, of the 16th Winnipeg Troop, who was in danger of drowning in the Assiniboine river, on Friday, the 25th June, 1915. His action was a very meritorious one, and the manner in which he discharged his duty speaks well for the training he had received.

He was presented with the Gilt Medal of Merit by Sir Douglas Cameron, Lieut.-Governor, in the Walker theatre on Thursday evening, the 6th of April, at 8.45.

one could lead them to develop for themselves the essentials of character, health, and handiness.

Dr. McMunn, in his recent work, "A Path to Freedom in School," has stated the traditional method thus:

"Some lunatic, having evolved the idea 600 years ago that boys must do their work precisely in the same way as adults, we have made that our idea of education ever since, with a so-called discipline which is that of hand-cuffs and fetters, not of will."

It is maintained by many interested in education that concentration on the part of the child is most essential to its successful education, but it is most difficult to obtain in school.

I don't know what happens in school, but I know that it is most easy to get concentration outside the school if you only give a child its own task to do in its own way.

The thing is to study a child and see what interests it. Look at a youngster making sand castles on the beach, how he will go at it hour after hour until he overcomes his difficulties, and builds up his castle to his satisfaction. He concentrates the whole of his thought and

the whole of his physical energy upon it. If you adapt such whole-hearted keenness to educational ends, there is no difficulty in obtaining the concentration desired.

This is exactly what happens in the Scout movement—on a step higher than the castles in the sand—but the success in results is entirely the outcome of the study of the child, and of utilizing his bent—whatever it may be—for his own development.

Does the school teacher get his certificate for knowledge of the child, or for knowledge of three "R's"?

The main step to success is to develop, not to repress, the child's character, and at the same time, above all, not to nurse him. He wants to be doing things, therefore, encourage him to do them in the right direction, and let him do them in his own way. Let him make his mistakes; it is by these that he learns experience.

Education must be positive—not negative—active, not passive. For example, the Scout law in each of its details says: "A Scout does"—this, that or the other.

Authorities have come along to improve the Scout law, and not recognising the active side of it, have changed it to the reverse—a series of "don'ts." "Don't," of course is the distinguishing feature and motto of the old-fashioned system of repression, and it is a red rag to a boy. It is a challenge to him to do wrong. Sought knowledge lasts, unsought does not. McMunn shows that children will seek knowledge all day and every day, will seek any knowledge you ask them to, if you let them seek it actively and in their own way.

Every boy is different in ability, temperament, and mind, and yet we try to teach them all in a heap the same things. One will come out top of his class because a subject happens to suit him, but he does not necessarily afterwards come out at the top in life.

We have been criticised in the Scout movement for offering such a large number of badges for proficiency in so many different lines. The object of this was, not that each boy should try to win all these badges, but to try and meet the enormous variety of character among the boys, and to give each one his chance by selecting his own subject. We do not perpetuate the school system, whereby the lucky boy who happens to be brilliant in one of the "r's" comes out top, and disheartens other boys whose abilities may be equally as good but unfortunately not in one of the subjects which come under the school curriculum. The aim of the proficiency badge is to encourage self education on the part of the boy in a subject which interests him.

### THE ATTITUDE OF SCOUTING TO CADET TRAINING

**Gloomy Forebodings Are Expressed That If Cadet Training Becomes General Scouting Will Go Under—I Don't See It Myself.**

The military value of cadet training in a country where you already have a standing army is not sufficient to guarantee a big outlay of taxpayers' money, and without funds it cannot be applied to much effect among the poorer classes—though an excellent occupation for well-to-do boys.

From the educational point of view its value is not considered by the authorities to be sufficiently great to justify its being introduced into the already overcrowded time-table of the schools.

So there are obstacles to be overcome before it can be generally introduced. Then its ultimate aim is so entirely different, and so partial as compared with that of scouting, that I do not see that the two movements can seriously disturb or interfere with each other. Quite the contrary—they can be mutually helpful in doing good for the country.

A Scout Commissioner in writing to me has touched on some further points of the case. He admits that if and when education committees grant the time, funds, and accommodation to cadets, Scout troops will be materially handicapped, but at the same time his experience shows that where real scouting is practised it is so much more permanently attractive and congenial to boys than cadet work that there is no fear of our losing boys. One of my Scouts last week summarised the situation: "They are taking our slackers—good luck to 'em." It is the inefficient troops that will suffer, and even if the movement had a temporary set-back in numbers it will I believe be a healthy competition and will tend to increase our real efficiency. I may say that in this district I anticipate as a matter of fact a substantial increase in our membership this year. We have established friendly relations with the cadets here, and are inviting their responsible officer to join our local association. Our Scouts' Defence Corps boys have undertaken to instruct the cadets in signalling—at the request of their officer.

A Scout recently wrote to ask me if he ought to join the cadets which his schoolmaster was raising in the school. I have replied that he would do well to be a cadet provided he did not leave the Scouts to do it. In Australia, New Zealand, and Canada it is quite possible for a boy to be both a cadet and a Scout.

Cadet training is very much like that of the Scouts' Defence Corps; it teaches a fellow to drill and manoeuvre so that if he goes into the army later on he will know something about the work and will not come to do it as a raw recruit.

But it does not teach him to turn his hand to every kind of useful job, to use his wits and to do the right thing at the right moment as Scouting does. It does not make him so useful all round that the government makes use of his services as it does with scouts for coast



Desperate Scout: "Please Sir, do you happen to have such a thing as a precept about you?"

Ma  
Se  
go  
grc  
Sor  
MU  
on  
Fiel  
Lon  
Nor  
Vell  
Rap  
Swe  
Man  
Frie  
Sigs  
Gard  
Bron  
West  
Time  
Alfai  
Clove  
Annu  
Annu  
Hovee  
Carm  
Drier  
Kilne  
Mortg  
Wree  
White  
Table  
Six W  
Honey  
Caragi  
12  
2-  
3-  
Lilac,  
15;  
3.4  
YOU  
Manito  
2-3  
Ontaric  
Cotton  
Elm 2-3  
Rusian  
3-5  
Rusian  
5-7  
We H:  
50,000  
255,000  
6,000 O  
55,000 I  
115,000  
70,000 E  
5,000 Cr  
stock of  
plants, et  
We gro  
For mor  
Fruits, s  
We l  
\$5.00 per  
and other  
PATMO  
Name  
Addr  
Pr  
watching, pol  
at the War  
recruiting off  
but here v  
officers are  
I could get  
company—the  
who have not  
thing, or who  
cadets—for v  
drilled by me  
and all they  
learned again b  
diets. We w  
trusted to m  
to please it m  
to any job and  
—as the Scout  
THE  
A Scoutmast  
of his chief a  
into the preser  
You can ne

# PATMORE'S RELIABLE NORTHERN-GROWN Seeds, Trees, Shrubs and Fruits

Seed time, the season when we lay the foundation of a good crop or a poor one, is close at hand. Good crops can be best assured only by using good seed. **PATMORE RELIABLE SEEDS** are selected from long years of experience, proving which varieties are the best and most profitable to grow here in the West. Reliable Flower and Vegetable Seeds, Grasses, Fodders, Farm Seeds and Seed Potatoes, of all the best hardy varieties.

**FODDER AND FIELD SEEDS**

Sorghum, a valuable fodder grass	Per 100	\$12.00
Millets, Common, Siberian, Hungarian or Japanese	.....	6.00
Field Peas	.....	2.25
Longfellow Corn	.....	2.50
North Dakota Dent Corn	.....	2.50
Yellow Dent Corn	.....	2.25
Rape Seed, per lb.	.....	.12
Swede Turnip, per lb.	.....	.30
Mangel, per lb.	.....	.30
Field Carrot, per lb.	.....	1.00
Sugar Beet, per lb.	.....	.30
Garden Peas, best varieties, per lb.	.....	.15

**GRASSES AND CLOVERS**

Brome, No. 1	.....	\$14.00
No. 2	.....	12.00
Western Rye, No. 1	.....	12.00
No. 2	.....	10.00
Timothy	.....	12.00
Alfalfa	.....	28.00
Clovers, Red	.....	28.00
Alsike	.....	24.00
Annual Rye	.....	12.00
Annual Crimson Clover	.....	14.00

We Grow and Offer For Sale 15 of the Most Productive of Garden Peas.

**SPECIAL OFFER—25 lbs. for \$2.00**  
Choice Garden Peas, best varieties: Telegraph, Fortyfold, Earliest, Stratagem and others.

**COLLECTION No. 1**  
Contains 22 varieties of our Reliable Vegetable Seeds in packets and ounces, 2½ lbs. of seed for \$1.25 prepaid.

**COLLECTION No. 2**  
12 packets of Reliable Flower Seeds for 25c. prepaid.

**FARMER'S COLLECTION No. 3**  
Contains 1 lb. Mangel, 1 lb. Sugar Beet, 1 lb. Swede, ¼ lb. Carrot, ¼ lb. Kale and 4 lbs. Rape—8 lbs. seed for \$2.50 prepaid.

In our Catalogue we offer 60 of the Choicest Varieties of Spencer's Sweet Peas.

**SEED POTATOES**  
Are likely to be very scarce

Bovee, per bushel	.....	\$2.00
Carman No. 3, per bushel	.....	1.50
Drier's Standards, per bushel	.....	1.50
Kidney, per bushel	.....	1.50
Mortgage Lifter, per bushel	.....	1.50
Wes. McGregor, per bushel	.....	1.50
White Sunrise, per bushel	.....	2.00
Table Talk, per bushel	.....	2.00
Six Weeks, per bushel	.....	2.00
Honeyeye, per bushel	.....	2.00

**SHRUBS FOR HEDGES**

Caragana, 6-10 inch seedlings	.....	\$ 1.00
12-15 inch seedlings	.....	3.00
2-2½ feet	.....	5.00
3-4 feet, selected	.....	15.00
Lilac, 12-18 inch	.....	5.00
1½-2½ feet	.....	10.00
3-4 feet	.....	15.00

**YOUNG TREES FOR LATE PLANTING**

Manitoba Maple Seedlings	.....	\$ 1.00
2-3 feet trees	.....	5.00
Ontario Soft Maple, 3-4 feet	.....	10.00
Cottonwood Seedlings	.....	1.00
2-3 feet	.....	5.00
Elm, 3-5 feet	.....	10.00
Russian Laurel Willow, 2-3 feet	.....	5.00
3-5 feet	.....	10.00
Russian Golden Willow, 1-3 feet	.....	3.00
5-7 feet	.....	10.00

We Have Growing in Our Nursery and Offer for Sale this Spring:

- 500,000 Caraganas, 1 to 4 feet high.
- 255,000 Native Maple, 1 to 10 feet high.
- 6,000 Ontario Maple, 2 to 6 feet high.
- 50,000 Lilac, 1 to 5 feet high.
- 115,000 Russian Golden Willow in all sizes.
- 70,000 Russian Laurel in all sizes.
- 5,000 Crab Apple and Plum Trees and a large stock of all hardy fruits, ornamental shrubs, plants, etc.



Lilac Hedge in Bloom. Photo taken Brandon, Man. These are needed for the comfort and health of the Western prairie home—the old-fashioned but ever popular Herbaceous Plants.

For more than 30 years we have been growing and selling Hardy Trees, Shrubs and Fruits, and all over Western Canada you will find homes made beautiful by the use of **Patmore's Hardy Trees and Shrubs**

We have this spring in good supply and quality, suitable for shipping any time during May, **RUSSIAN GOLDEN WILLOW**, 1-2 ft., \$3.00 per 100; 3-4 ft., \$5.00 per 100; 7-8 ft., \$10.00 per 100; **RUSSIAN LAUREL WILLOW**, 2-4 ft., \$5.00 per 100. **GROWING PLANTS:** Sweet William, Pansy, Campanula, Peony, Iris, and other herbaceous plants which live through our winters, \$6.00 per 1,000 photos of Western growth, and compiled with the experience of 30 years in this Western country. Write for it to-day.

**PATMORE NURSERY CO., LTD., BRANDON, MAN. C.T.**

Please send me your Illustrated Free Catalogue.

Name .....

Address .....

Province .....

**THE PATMORE NURSERY CO., LTD.**

BRANDON SASKATOON  
Man. Sask.

The Oldest Horticultural Establishment in the West

ESTABLISHED 1883

watching, police duties for orderly work at the War office, Admiralty, hospitals, recruiting offices, etc.

But here where I am, at the front, officers are always saying to me: "I wish I could get more old Scouts into my company—they are worth ten of those who have not been trained to do anything, or who have been drilled only as cadets—for very often cadets have been drilled by men who were not good at it, and all they have learnt has to be unlearned again before they make good soldiers. We want fellows who can be trusted to do their duty, however unpleasant it may be, to turn their hand to any job and keep smiling all the time—as the Scouts do."

**THE POWER OF GOD**

A Scoutmaster once told me that one of his chief aims was "to bring boys into the presence of God."

You can never bring boys into the

presence of God because they are in that presence always.

That is one of the things to remember in considering religion for boys.

Our scouting is "Scouting for Boys," and when we are talking about the directly religious side of our work, we must remember that it is religion for boys that we are speaking about, and not the religion of elder people, which they so often think boys ought to have.

It is almost too old a saying, "a boy is essentially a religious being," but it is well to remember that true religion is something that comes out of the boy's own heart.

We can, however, help boys to realise the presence of God. There is nature study, for example, and the revelation of God through human beings, and the power to resist sin. Every boy knows he has some power of this kind, but he may not realise it is the power of God.

Help your boys to realize the need of God, that He is absolutely necessary for the carrying on of their troop. Take the Scout promise and the Scout law as the absolute basis of the Scout movement. Hold these up as the highest ideal to your Scouts, and let them realise their importance. Then you will find that the boys understand the need of the presence and the help of God. They will, in fact, gradually begin to understand the Christ ideal.

When you try to climb the highest mountain you need a rope to help you, and, as Scouts, when you are trying to climb to the highest ideals, we must have the help of God. The boys will understand that. If you have your court of honor and speak frankly on the Scout laws, the demand for the highest and strongest help will come from the boys themselves.

The "Scouts' Own" must be the result of the boys' religion and their desire for

help. You must not have one to force religion on the boys.

There is a great battlefield of sin in which our boys must take part, and you will find boys who are ready to take their part in this battle, and who will go down on their knees to ask for help and to thank God because their troop is doing well.

In the great war with Germany I am certain we are going to win. I cannot tell you why I am certain, but we all feel it, and perhaps the reason is that we are all determined to endure to the end.

We believe that our nation has a reserve of strength that will enable us to get up again and again, no matter how often we may be knocked down. It is just the same with Scouts, and the power of God. When our Scouts seem down, or our troops seem down, we have always this wonderful power to lift them and us up again.

# OUR WOMEN FOLK

CONDUCTED BY  
PEARL RICHMOND HAMILTON

**THE LITTLE COMMONER**

By Daniel M. Henderson  
 'Tis not through great orations,  
 Or by reading history,  
 That I catch the fullest meaning  
 Of the word Democracy.  
 For I've a baby daughter,  
 And I've marked well how she greets  
 The servants and the tradesmen  
 And the strangers whom she meets.

While she upon her family  
 A wealth of smiles bestows,  
 To Norah in the kitchen  
 As warm a greeting goes;  
 And the wee one's gay advances  
 And her gurgles of pure joy  
 Are the same to ragamuffins  
 As to well-dressed girl and boy.

Her spirit is contagious—  
 It has spread about the place;  
 It warms the coldest glances,  
 And melts the frostiest face;  
 And I move among my fellows  
 In a cheerier, kinder mood,  
 Since the loving little lassie  
 Came to teach me Brotherhood.

**THE FRIENDLY KIND**

By Mary Carolyn Davies  
 If you are of the friendly kind—  
 On this it all depends—  
 You're really very apt to find  
 The world brimful of friends!

**NOTICE**

Mrs. Dumbrell, of Headingly, has asked me to inform our readers that so many requests came in for flower seeds that her supply of flower seeds was exhausted before the end of three weeks, after the magazine article was published. In that time she answered over three hundred requests and she said letters were coming in so fast that it would take a wholesale house to answer the requests. I am glad the article was so popular. It proves that our women are very much interested in gardening, and I wish our readers would write to our department on any phase of gardening. We want your experience for our readers. If enough letters of experience are sent in we might have a corner in our department on gardening.

**Home Economics**

**PILOT MOUND**

The H.E.S. of Pilot Mound has given up its usual program and substituted Red Cross work instead during the past twelve months. It was felt by the whole society that addresses, etc., were entirely out of place at a time when deeds, and not words, would tell the most. With a society of 75 keen-to-work members, the main problem has been to provide work enough to satisfy every one. At a meeting when a Red Cross program was unanimously agreed to every one was of the opinion that it would be a mistake to sew in sections. That would be to destroy the community feeling which the H.E.S. has taken four years to build up. Some one hit upon the brilliant idea of collecting and taking to the hall ten or twelve sewing machines at the beginning of the week in which the H.E.S. meeting falls. Pilot Mound is fortunate in possessing a fine hall, built by the C.O.F. order. The well lighted, airy meeting hall on the ground floor is scarcely more useful than the well built basement below, where long tables, cookstoves, cutlery and china make it a simple matter to arrange basket dinners, suppers and other

social events. In this hall for the past twelve months Red Cross sewing has been done for five consecutive days each month. During this time of sewing some members cut out, while others sew. On the H.E.S. day, the Saturday, there is always a crowded meeting. To this are brought contributions of socks and hospital garments, made by workers in districts who are too far away to come to town oftener than once a month. These small outposts of the H.E.S. are fulfilling the main object of the institution, viz., the reaching out to the far-off spots where more than anywhere else, the women need the inspiration such as is given by our great sisterhood. The convener of this Red Cross work must be a woman above the average. She must have abounding energy, business ability, and a thorough knowledge of cutting out. She must have, more than all else, tact. Give such a woman a good, energetic committee to help cut out and ship the finished garments, and it is marvellous what can be accomplished. During the February (1916) sewing week, the attendance was so large that it was decided to have some quilts ready to quilt at the March meeting. A committee was asked to collect patches and to get them pieced. In March and April 16 quilts were completed. Some were sold by private sale; the rest by auction, the whole realizing \$62.50 for the Red Cross.

Some one, perhaps, will ask, "How much does the Red Cross work cost the H.E.S.?" It costs the H.E.S. nothing. Some months as much as \$50.00 worth of stuff is cut up, but the Red Cross Society secretary, the station agent, foots all the bills. He gets Red Cross subscriptions from the town and district to the figure of \$100.00 a month, and some times more. This comes to him partly direct and partly through the local war relief

association, which exists to collect monthly subscriptions from the men. The women of Pilot Mound and district are not asked to collect patriotic subscriptions—the men do that, and by their generosity provide the material for the women to make up. This is only as it should be. The monthly subscription also does away with the need of Red Cross 10 cent teas, by which plan one is induced to eat an extra meal in war time, when one should be eating less, for the good of the Empire, and for the sake of one's own health.

For two years the H.E.S. has kept a rest room open for the convenience of the district. The rent is paid by the town council, and the country council (Louise) pays \$30.00 a year. Another \$50.00 besides is needed, and has so far been provided by small individual subscriptions, and an annual baking sale. An interesting discussion on rest rooms at the H.E.S. convention brought it home to most that eventually this rest room scheme must be financially backed by municipal grants entirely. The voluntary system has been tried and found wanting. The half-and-half method is wanting too, and not so successful as the public financial scheme. This may be universally adopted in the future, when all municipal councils are convinced that rest rooms are a civic necessity. In the meantime it is for the H.E.S. to prove this and to keep rest rooms going, until the time when municipal councils are less involved in war relief.

Another feather in the Pilot Mound community cap is the Boys' and Girls' Club, which would never have been undertaken without the whole-souled support of the H.E.S. In 1915 the Club, with 93 members, held a most successful club in October. The expenses, which worked out at \$1.00 per member, were rigidly kept down, and were met by small grants from the school districts.

Five dollars per eight members was asked from each school district, and the balance was supplied by the government grant. This year (1916) the membership promised to be so great that a central trustees committee has been formed to back the club work, and to see that sufficient money is forthcoming to meet the increased expense. This committee of representatives from ten school districts took its origin at a trustees' association meeting in February, 1916, at which the club work formed a very prominent feature. At this convention there was a record attendance. The H.E.S. managed a basket dinner and supper in the basement. Husbands and wives, trustees and teachers, sat down to excellent meals, and adjourned afterwards to the meeting, where excellent discussions followed the items on the program. The fine community spirit and the good will prevailing were noted with approval by the visiting speakers. The greatest result of this most successful convention has been the unifying of the widely-separated school districts—the bond of union being the H.E.S. and the Boys' and Girls' Club. This trustees' committee has since met and voted enough money to provide prizes for the Club fair, and to pay the expenses of a short course of manual training in July.

At the February H.E.S. convention at the M.A.C., one listened in wonder and amazement to the account of the magnificent work done by the H.E.S. The representatives of the Pilot Mound society returned home, more conscious than ever that their own community was especially fortunate in the possession of public-spirited men, who do their part nobly, as men, and with whom it is an ever increasing joy to co-operate, as the H.E.S. has ever done since the day it was organized.

**MIAMI**

A short course week in millinery and two demonstrations in cooking were given in Miami rest room beginning Monday, the 20th. The two demonstrations in cooking by Miss Crawford of the M.A.C. proved very helpful and were very successful, there being 58 ladies in attendance at the two sessions. Miss Crawford gave a helpful talk at each demonstration which the women very much appreciated. Too much cannot be said of the capable manner in which Miss Crawford holds the attention of the women. It was unanimously carried that we secure for our society one week of cooking demonstrations by Miss Crawford preferably the last week in October. The short course in millinery by Mrs. Graham and her assistant, Miss Astley, was splendid. The sessions were as follows: Monday afternoon, 20th, 23 women at work. Tuesday morning 21, afternoon 30. Wednesday morning 24, afternoon 36. Thursday morning 26, afternoon 38, evening 33. Friday forenoon 15. Making nine sessions in all. I cannot express in words the satisfaction of the women for the work done by Mrs. Graham. There were 37 hats finished in the room during this course, with several shapes given out, while some secured trimmings and many had instructions for doing over hats. The time was far too short as we could easily have had as many more at work. There visited the room during the week including those who made hats over one hundred women. One afternoon could have been given to flower cutting as over 20 ladies wished to attend and special requests were made for instructions in making bows, but owing to the necessity of having to finish the hats it was not possible to accomplish this. Mrs. Graham and Miss Astley left on the 11:45 train Friday forenoon for Winnipeg.



**YOU can buy a Dingwall Diamond Ring with absolute confidence in its fine quality.**

Our fullest guarantee as to its fineness of color—a pure white—freedom from flaws, and perfect cutting goes with each ring we sell, and backing the guarantee is our reputation for straightforward merchandising gained in 33 years' business in Winnipeg and the West.

The rings illustrated are our special \$75.00 line in 3 different style settings; others from \$10.00 up are fully shown in our catalogue.

SEND FOR A COPY OF OUR ILLUSTRATED CATALOGUE NOW. IT WILL BE SENT FREE OF CHARGE.

**D. R. DINGWALL**

JEWELLERS AND LIMITED DIAMOND MERCHANTS WINNIPEG MANITOBA

The H.E.S. v interest in the conv gates, A Charles, a discuss for both. The se ported si had been A tea hel ing of Mi which wa materials After a closel, w. Anthem.

The A H.E.S. w: hall. The "Large v Furnishin given on and much to the rel: kitchens i: divided. ported tw March, w socks, 22 four hot w pillows, fo linen, one of linen i in \$31.50, the Rest I the usual n to buy ma

Mrs. Ar gave a mo Hankurst' the she l This was k and I think had this op ing this gift

Mrs. Ar good work cent Home nipeg, and a little by This month eggs.

After the by quotatio tea was serv

Dear Mr meeting of held in the b church, with Price, in the usual b interesting pu ing by Miss A Change and I a piano solo much apprec Mrs. Price the conventic February, af Home" was d and all nec They decided date for said in the Methc good program vocal and inst short address chosen for lun evening was ing "God Sav letion was tal Cross society, saying that th At Home eve Deloraine.

The April H.E.S. was c Presiding. Th National Anth ing were read Mrs. Price s have a Strang being that the pointed: Mrs Steelsman, M Perry and Mrs then favored the which was muc the subject "Preparation o Cultivation a Whole." "Ra papers were gi man, Mrs. Geor lu and Mrs. J.



**MANITOU**

The March meeting of the Manitou H.E.S. was largely attended and very interesting one. Very full reports of the convention were given by our delegates. Mrs. Seymour and Mrs. Mac Charles. All the members took part in a discussion as to labor saving devices for both town and country homes.

The secretary for Red Cross work reported sixty pairs of socks, all hand knit, had been sent from our society this month. A tea held in the curling rink on the evening of March 25th had brought in \$22.35, which was used to buy wool and other materials for Red Cross work.

After a very dainty tea, the meeting closed, with the singing of the National Anthem.

The April meeting of the Manitou H.E.S. was held as usual in the Orange hall. The paper for the day was on "Large versus Small Kitchens, Kitchen Furnishings, etc." A splendid paper was given on this subject by Mrs. Atkinson, and much discussion followed; opinions as to the relative merits of large and small kitchens seemed to be pretty evenly divided. The Red Cross secretary reported two shipments of goods during March, which consisted of 43 pairs of socks, 22 surgical shirts, one day shirt, four hot water bottle covers, 12 comfort pillows, four night shirts, one roll of linen, one roll of cotton and eight rolls of linen mouth wipes. Mrs. Tait gave in \$31.50, the proceeds of a tea held in the Rest Room, and this, together with the usual monthly collection, will be used to buy materials for Red Cross work.

Mrs. Armstrong, our president, then gave a most interesting account of Mrs. Pankhurst's recent lecture in Winnipeg, which she had the pleasure of attending. This was keenly enjoyed by all present, and I think every one of us wished we had had this opportunity of seeing and hearing this gifted lady from England.

Mrs. Armstrong also described the good work being done by the Convalescent Home for returned soldiers in Winnipeg, and our society decided to help a little by sending a monthly donation. This month we sent a crate of new laid eggs.

After the roll call, which was answered by quotations from Burns, a delightful tea was served by the committee in charge.

**DELORAINE**

Dear Mrs. Hamilton—The March meeting of the Deloraine H.E.S. was held in the basement of the Presbyterian church, with the vice-president, Mrs. Price, in the chair. After the opening, and the usual business transacted, a very interesting program was given. A reading by Miss Auston entitled "Mrs. Brown's Change and Rest," by Mrs. McClung, and a piano solo by Miss Cowan, were both much appreciated.

Mrs. Price then gave a full report of the convention held in Winnipeg during February, after which the annual "At Home" was discussed, committees formed and all necessary arrangements made. They decided upon March 17th as the date for said At Home, which was held in the Methodist church basement. A good program was arranged, composed of vocal and instrumental music, and a few short addresses, after which partners were chosen for lunch, when a very enjoyable evening was brought to a close by singing "God Save the King." A good collection was taken at the door for the Red Cross society. All were unanimous in saying that this was the most enjoyable At Home ever held by the H.E.S. of Deloraine.

The April meeting of the Deloraine H.E.S. was held in the basement of the Presbyterian church, Mrs. R. J. Price presiding. The meeting opened with the National Anthem. Minutes of last meeting were read and approved.

Mrs. Price suggested that this society have a Strangers' Committee, the result being that the following ladies were appointed: Mrs. S. B. Perry, Mrs. Jas. Steedsman, Mrs. Fisher, Mrs. C. W. Perry and Mrs. McKinnon. Mrs. Owen then favored the meeting with a violin solo which was much appreciated. Gardening was the subject taken up, divided as follows: "Preparation of the Ground," "Sowing and Cultivation," "Fern Gardening as a Whole," "Raising of Flowers." These papers were given by Mrs. W. Steedsman, Mrs. George Perry, Mrs. W. Franklyn and Mrs. John Morrison.

Costs a little more than the "other kind" of flour, but worth it in the quantity and quality of bread you bake with—

**PURITY FLOUR**  
More Bread and Better Bread  
WESTERN CANADA FLOUR MILLS CO., LIMITED  
Millers to the People

31

Mrs. Terryberry then gave a talk on "Spraying, and the Control of the Cutworm, etc.," after which Mrs. Fisher gave a paper on gardening in general. These papers led to some discussion.

Mrs. Beveridge and Mrs. A. Benton invited the ladies to remain for a cup of tea, proceeds of which amounted to \$4.75. A vote of thanks was tendered all who helped with the program, also the ladies who served tea.

Rather would she pray to God He would keep her baby good; Be he weak, or poor, or sad, May he flee from all that's bad! Nothing else can make us glad But to tread the narrow way, Toiling slowly day by day, Lest we miss the path of right, Keeping heaven in our sight.

This shall be her prayer for you: "May He keep you good and true! May His angels ever spread Shelt'ring wings around your head! Angels, ever near to guide, Lead you onward to His side, Through your earth-life ever on, Till the crown of life be won."

—Diana Legge.

U. S. Children's Bureau. To teach mothers of the community how to care for their babies and to establish permanent work for their welfare is a most important movement. Every real woman loves babies, as does every real man.

Alfred Vanderbilt's last sentence on the Lusitania was: "Let's save the kiddies!" God bless the babies—every one! Let us do all in our power to make them healthy and happy.

**A MOTHER'S VISION**

The following taken from the editorial page of The Woman's Magazine may be an inspiration to some mother who is discouraged: There is no wisdom like a mother's wisdom.

It is not schoolhouse learning. Neither the spoken word nor the written line has been her teacher. Christ and His apostles got their immortal wisdom out of their own hearts.

The philosophers whose teachings have come down from century to century touched the fundamental truths of life because they studied mankind. The greatest wisdom in all the world was learned before books were known.

And so it is with mothers. Many a mother at a cook-stove has told her daughter a wise truth that has started the girl right in life.

The light of heaven falls into the hearts of praying mothers.

The best that is in our lives has been planted there by a mother. Her hopes and her faith have been an inspiration and a reproach.

When you find a man who has made good you can be pretty sure he knew the guidance of a mother's hand. It may have been an old-maid aunt or a grandmother or an older sister who brought him up, but some woman gave him that unselfish affection that is born of conscience and classed as mother-love.

Dr. Eliot told me, in his eighty-third year, that one of his chief ambitions had been to crown his life-work with the history of his mother. The beauty and strength of her character were the biggest influences in his long and noble life.

**The joy of service**

The two most famous surgeons in America, Dr. Charles and Dr. Will Mayo, had an old-fashioned mother who taught her children the simple virtues and the joy of service. At eighty-nine she told me she had brought up her children to believe in service.

"If one just says: 'I'm going to be useful until I drop,' it helps a lot," she told me, in explaining how she adjusted her life to blindness when it came upon her

**Mother's Corner**

**MOTHER'S WISH**

Baby, with the eyes of blue,  
What shall mother wish for you?  
Shall she wish your dimpled feet  
E'er to tread a path so sweet;  
None but loving words to hear,  
With your rosy little ear,  
Health to tinge your dainty cheek,  
Riches you need never seek?  
Shall she wish all this for you,  
Baby, with the eyes of blue?

**A NATIONAL BABY WEEK**

A national Baby Week, from March 4th to March 11th, had for its object a nation-wide baby welfare campaign in the United States. This movement was initiated by the General Federation of Women's Clubs, in co-operation with the



"Lor, Mrs. Green, you ain't looking yourself at all this morning. Whatever do be the matter with you?"

"There, Mrs. Budd, you know the trouble we've allus 'ad with our George, an' now ah've a postcard this mornin' sayin' as 'ow he's got t' V.C., and me an' 'is father teetotalers all our lives!"

was asked  
he balance  
ent grant.  
ship prom-  
al trustees  
back the  
ent money  
increased  
representa-  
s took its  
club meet-  
it feature.  
a record  
naged a  
the base-  
astes and  
nt meals,  
the meet-  
s followed  
The fine  
will pre-  
al by the  
result of  
has been  
separated  
ion being  
nd Girls  
has since  
to pay  
to pay  
f manual

ention at  
nder and  
e magni-  
S. The  
and serious  
than  
city was  
ession of  
eir part  
it is an  
, as the  
y day it

ery and  
re given  
g Mon-  
strations  
of the  
ere very  
attend-  
ford  
stration  
eiated.  
capable  
1 holds  
It was  
ure for  
on-stra-  
ly the  
course  
nd her  
l. The  
after-  
uesday  
uesday  
uesday  
ng 23.  
essions  
Is the  
work  
ere 27  
g this  
out, many  
The  
easily  
There  
clud-  
h-un-  
have  
er 29  
al res-  
in-  
osity  
not  
Gra-  
11.45

in her youth. In summing up her philosophy she said, "Life is just a day's work."

One of her maxims was this thought of Emerson's: "Though you live in the heart of a forest, if you have something the world wants, it will cut a path to your door." That motto, embroidered with her own hands, hangs in the office of her famous sons. It was made for their father and is probably the answer to the question so often asked: Why do the Mayos stay in Rochester?

John Purroy Mitchel, the young reform mayor of New York, began to learn wisdom at his mother's knee when he was in kilts. One of her teachings was: "If you want to be respected, you must respect others; you must consider the rights of others, their property, their opinions, and most of all, their religions."

**When Christy Mathewson Learned Fair Play**

Christy Mathewson, the most beloved sportsman in the country, had a mother who taught him to "play fair."

"Honesty is the biggest thing in life," she told Christy, "and to tell the truth is the first part of honesty."

"There's something in life worth more than money," she taught her children. "oney can cost too much. A home is to live in. It's for your children and their friends. Any boy or girl who has friends who can't be brought home, has begun to pile up trouble."

"When you don't really have to come home and bring your friends there—there's something wrong with you or your home. Better find out what's wrong, and make it right."

Here are a few of my mother's old sayings:

"No bed is soft unless a clean conscience is on the pillow."

"Live so that each night you can look into your mirror unashamed."

"Musical education should begin in the cradle," says Dr. Frank Damrosch. "The baby should hear soft, melodious, correct singing every day. If the parent cannot supply this, so much to the detriment for both parent and child. For it cannot be too often repeated that the songs of a nation's children play a leading part in moulding that nation's mind and spirit."

Little pitchers have far larger ears than many of us realize. Dr. Wm. Hanna Thomson, an eminent student of the human brain, says that parents often underestimate a young child's ability to understand words; and then, some months afterwards are surprised to discover that he knows so much. "If words once begin to reach through the ear, the mind springs forward to its limitless nimbleness of thought, and especially of feeling. It is the ear, not the eye, which moves the heart."

**AMUSEMENT FOR CHILDREN**

When children are recovering from an illness it is difficult to provide amusement for them—yet it is an important factor just at this time to keep them light hearted and at the same time conserve the slowly gaining strength. Then,

**22-inch Switch  
\$1.98 Special**

**Switches  
Hair Goods**

Ladies, send us your combings. We make them up into switches at 50c per ounce.

We will add new hair as desired to combings at from \$2.00 upwards.

*Satisfaction Guaranteed*

**Elite Hairdressing  
Parlors**

207 Enderton Building,  
WINNIPEG

# SIMPLICITY in SHOPPING

**WITH an EATON Catalogue in hand, sitting in the quiet of your home with no crowds to worry you, no one continually at your elbow urging you to buy—this is the ideal way of shopping.**

Displayed for selection you have a most extensive range of different classes of finest quality merchandise — the immense stocks of a big city store.

You can see at a glance through the pages, goods that take hours of shop-to-shop searching to disclose, and in a final choice—with everything so accurately described and illustrated — have complete assurance that your purchase will entirely fill the need.

This simplified manner of solving shopping problems and assurance in buying, are factors that so closely link customer to the EATON Service—that make repeat orders the consequence of a trial order.

It will interest and profit you materially to have an EATON Catalogue in possession, and your name with address on a postcard, requesting our latest issue, will place you on the EATON Mailing List of satisfied buyers.

**THE T. EATON CO. LIMITED**  
WINNIPEG CANADA

too, well children have a habit of saying: "Mother, I don't know what to do."

Here are a few suggestions:

There is that magazine of last season's fashions, many of them colored; with a pair of blunt scissors the inherited tendency to cut out paper dolls can be indulged. Any creature, however, with as little backbone as the members of the Fashion Plate family, is "Not much fun to play with." Perform the simple operation of pasting a strip of paste board from tip to toe, another across the shoulder blades and the debutante slouch has completely vanished.

To lend variety and afford many hours of amusement, buy a dozen sheets of colored paper, both crepe and smooth, for the making of new dresses.

But of all the dolls, old-fashioned Miss Rag is the most comforting in time of trouble, for beside being soft and cuddly she is quite impervious to pin pricks. Our little modiste, armed with a paper of safety-pins and a box of ribbons and silks, of which there is an unending supply in the piece trunk, drapes and fits her patient customer in most original styles.

My little girl enjoys dressing clothes pins. I buy several sheets of crepe paper in different shades and with a bottle of paste she designs pretty styles.

Landscape gardening is another fascination to children.

The plot for the site is a tray with a wide brim set upon the bed table. First rob the sand-box of a panful of sand, with which to cover the bottom of the tray, then supply the little gardener with

pebbles for paths. A rock garden of small stones can be made in one corner, while bits of evergreen, ferns, and if possible, early spring flowers are grouped into a charming garden. With mother as assistant gardener, summer-houses may be cut out of paper and a bridge or garden seat fashioned from cardboard. When through for the day the assistant gardener removes the entire country place and sets it in the closet until again called for.

The desire to "make something for father," can be gratified with ease, and the thankfulness with which the gift is accepted at the day's end will brighten the hours which are hardest to bear. Give the child a deep cardboard box and bits of left-over wall-papers, and cut out the flowers and figures. Paste these on the sides and cover and present to father, who will obviously use it for anything from shoes to shirts. In the same manner may a discarded lamp-shade frame be decorated, first pasting a foundation of new wrapping paper. The more fantastic and silhouetted are the figures the greater will be the child's delight, when by the low lamp-light mother tells the good-night story.

Home-made linen scrap books are excellent. A child enjoys buttonhole-stitching the edges of the pages with colored worsteds, and added amusement will be found in severing the heads from their proper figures and pasting them on others.

When sympathetic friends ask, "Is there any way that I can help?" The quick-witted mother will reply, "There

surely is, if you will be so kind. Please join the entertainment committee, and supply us with some common clay or colored worsteds; even lemonade straws which may be purchased from the soda water man will be most acceptable."

This diversified list may astonish but will scarcely tax the financial resources of mother's friend.

The cool, pliable clay will feel pleasant in summer 's the fingers as they mould a dog, cat or rabbit for the country place. The tiniest invalid can form a bird's nest and eggs, the latter being tinted with water-colors. Flowers are easily made by forming petals, coloring them, then molding one by one about the stem. To keep the unused clay soft, place in a covered crock.

Lemonade straws are indispensable for making dining-room sets. They are used for the legs of tables and chairs and for backs of chairs and sideboard. Soft new paper is cut for the table top. Cut the straws the desired length, then pass one through each corner and stick a pin in the straw for the top to rest upon.

Colored worsteds are used upon a variety of medical charts. If the child is too young or has not learned to crochet take the end of the ball, make a loop and even baby fingers can pass the worsted through loop after loop ad infinitum.

The first day start with a very dull color and each day that progress is made in the patient's recovery, a lighter shade should be used until the day of days arrives, when the doctor pronounces the patient sufficiently well to take the day

M  
niri  
is fi  
N  
spot  
Who  
about  
is w  
for i  
ping  
color  
war  
white  
great  
are  
carge  
board  
that  
luxur  
soon  
count  
after  
boun  
ishly  
hold l  
A  
most  
kind  
When  
can b  
fire-pl  
family  
windo  
wines  
and hi  
Is t  
ience  
time l  
when  
to be  
Here  
made c  
chase  
quantit  
it. Ha  
the chi  
ward f  
dose, al  
the bag  
One c  
to the  
the pre  
sleep n  
for the  
has recel  
a fairy  
window  
little "J  
lotter o  
the child  
to hasten  
where av  
FA3  
The pe  
mothers  
ters, to sh  
confidence  
wise coun  
lems. Bu  
blant an  
him ment  
From e  
would see  
fitted to l  
help her d  
tions she  
mother car  
in the worl  
men talk  
the shop  
the man's  
in the worl  
to distingui  
the weak  
petent fro  
But how  
daughter's  
her interest  
she is a tir  
manhood  
to come to  
her sorrow  
dences and  
learn to be  
It takes a  
to win and  
harsh critic  
rections are  
fluency-gain  
While sugge  
given will be  
ism is not ar  
If a girl r  
boon compan  
that she can  
that concerns

airing and this apparently endless chain is finished with a dash of white.

Now we will sail away to the land of sport in the newly built newspaper boat. What tales of adventure can be woven about this ship? Only part of this fleet is weighted with the news of the world, for some of the ships are built of wrapping paper and decorated gaily in crayon colors. Neither are all of these men o' war, for some carry the one product upon which there is no duty—rice. Cake is in great demand also candies and cookies are insisted upon as being legitimate cargoes by our canny little trader. The board of commerce, however has decreed that only rice shall be bartered and the luxuries of the culinary department are soon forgotten in the fascination of counting with miserly correctness grain after grain as it passes into the boat bound for an unfriendly country, or lavishly pouring a slippery mass into the hold bound for a starving nation.

A gift of construction blocks will be most welcome, and the cheap wooden kind will serve its temporary purpose. When the day of recovery is at hand they can be formed into a house, set in the fire-place, and with the Fashion Plate family leaning frantically from every window the convalescent youngster can witness with many a thrill a complete and harrowing conflagration.

Is there a mother who has not experienced at least a slight dread of the nap-time hour and of that trying moment when the loathsome oil or bitter pill has to be administered?

Here is a remedy, the "Sunshine Bag," made of bright yellow cheese cloth. Purchase at the five-and-ten-cent-store a quantity of tiny toys with which to fill it. Have medicine and bag brought to the child at the same time, and as a reward for a speedy dispatch of the hated dose, allow the eager hand to steal into the bag and draw forth a surprise.

One of these prizes may also be offered to the child who has rested quietly for the prescribed time. But for the fast-asleep nap there is still a greater treat for the imagination; when the baby mind has reached the shores of Far Away Land, a fairy steals through the slightly open window and with gentle fingers tucks a little "Joy Toy" beneath pillow, comforter or spread. Each day thereafter the child gladly embarks on Sleepy Boat to hasten the return to Wide-Awake Land, where awaits him the hidden treasure.

Father's Corner

FATHER AS A CONFIDANT

By Estella M. Place.

The periodicals teem with advice to mothers to live close to their daughters, to share their interests, to win their confidence, so that they can give to them wise counsel when they meet life's problems. But what of the father as a confidant and counselor? We never hear him mentioned.

From experience and observation it would seem that the father is peculiarly fitted to be the daughter's counselor to help her decide the most important questions she has to meet—fitted as the mother can never hope to be. He is out in the world and he knows life. He hears men talk as man to man in the office, the shop and on the street. He gets the man's point of view as no woman in the world and he knows life. He hears to distinguish the dross from the gold, the weak from the strong, the incompetent from the promising.

But how is the father to win his daughter's confidence? He must make her interests his interests from the time she is a tiny tot until she reaches womanhood. Encourage her from babyhood to come to him with her joys and with her sorrows. Encourage little confidence and secrets. In fact he must learn to be a good all round pal.

It takes an unlimited amount of tact to win and hold a child's confidence. A harsh criticism when mistakes or indiscretions are confided may undo an influence gained by years of patient effort. While suggestion kindly and skillfully given will be gladly received. Antagonism is not aroused but confidence is won.

If a girl reaches young womanhood a boon companion of her father, feeling that she can go to him with every thing that concerns her, no matter how trivial,

and find a sympathetic listener she is indeed well fortified to meet the many perplexities that will come to her.

Among these perplexities there is one that calls for wiser counsel than her relations to the opposite sex. Her father knows men. He can see danger where neither the daughter nor the mother can recognize it. He knows that many men that want to lead clean, pure lives are tempted unwittingly by girls with no thought of wrong. By suggestion he can lead her to avoid even the appearance of evil. He knows that evil minded men take undue liberties with evil intent. He also knows that the friendship between a pure minded girl and a high minded man is one of life's choicest pleasures.

The evil minded man will not take liberties with the girl that confides in her father. The unsophisticated mother often attributes such actions to love or infatuation whereas the father knows that the true man treats the woman he loves with the utmost consideration. The father may lack sentiment but he usually has a full quota of common sense in such matters.

I am not belittling the beauty of a mutual understanding and affection between mother and daughter but I do contend that it is usually the father that is the safe and sane adviser. And the father has the daughter's welfare as much at heart as has the mother although he is too often treated as only the bread winner. When he is content to assume this role and shut himself out

THIS STOVE PAYS FOR ITSELF IN SAVINGS

For economy, if for no other reason, you need a New Perfection Oil Cookstove. From five to ten cents per day is its fuel cost for the average family—cheaper than coal, wood or gas.

The New Perfection brings all the comfort and efficiency of gas. Instant heat. Perfect regulation for any cooking. No smoke or smell. No overheated kitchens. No fires to build, no wood to chop, no ashes, no dirt.

Made in all sizes including the cabinet models with the fireless cooking oven.

For sale at moderate prices at hardware, furniture and department stores everywhere.

Royalite Coal Oil is Best for All Uses.

THE IMPERIAL OIL COMPANY Limited

BRANCHES IN ALL CITIES



RM

of the recesses of his daughter's life he is depriving her of a protection that he can give as can no other.

Now this magazine is going to have a Father's Corner and I trust our readers will contribute material for it

WHEN FATHER COMES AND GOES

By Florence N. Munn.

There is never a time when we have no opportunity to stand by father. Even in the ordinary routine of life when there seems no special call for demonstration in any way—when father comes and goes in the home life without visible evidence of any change from the beaten track, paying the bills and providing the necessities and comforts to which we have been accustomed there is always a chance to make our presence felt.

He, too, perhaps, has come to consider it a matter of course that all these things are to be provided by his hand—in fact, he loves to do it—and looks for no assurance of gratitude or appreciation. Nevertheless, this condition is not without opportunity to stand by him in a way that counts. Do you think, my girls, he never feels weary and disheartened with the routine of work and business, even at its best and most prosperous stage? But it compensates for all the difficulties and irritations of the day, to come home to a daughter who appreciates. It cheers him unspeakably that she has remembered his favorite dish and has prepared it with her own hands, without suggestion from him—that she even bears

in mind his preference for certain colors, as to her dress. "Father likes me best in white," said a young girl, and those hearing the words and seeing the look which accompanied them could but feel that she was a "father's girl" in a wider sense than the mere matter of dress indicated.

We may not always know of these special times of father's need, for usually there is nothing about his appearance to indicate disturbance. The only safe way is for us to have the "stand-by" spirit—the constant attitude of love and watch care. The quick glance of gladness at his coming—the cheery welcome—the "I'm ready for you, daddy," as the door opens all these attentions may mean more than we think, and help to lift a load.

Pathephones

Pathe and Diamond Double Discs No need to change—convenient records. At last! All gramophones can play without needles.

If you want Real Music own a Pathe- phone \$20.00 up



The Pathe Sapphire never wears out Pathe Discs 75c up

Absolutely Free FITS INSTANTLY ANY GRAMOPHONE. Sapphire Reproducer given absolutely free. Write for particulars and catalogues. New shipment of records just received. THE CANADIAN PHONOGRAPH AND SAPPHIRE DISC CO. 505 Builders' Exchange Bldg. Winnipeg, Man.

# An Open Letter

Hon. W. R. Motherwell on Fallacies of "Production and Thrift" Campaign

To the Editor,  
The Canadian Thresherman and Farmer,  
Sir,—The writer has been asked so frequently by the agricultural and general press for an opinion on the agricultural merits or demerits of the Federal government's Production and Thrift campaign as it deals with crop and tillage for the spring of 1916, that I have concluded to address a letter to the press commenting on this very important subject.

A widely circulated advertisement issued in connection with this campaign contains the following paragraph: **Stubble Land of Second Crop After Fallow.**

"Usually this land should be summer-fallowed, but this year much of it must be in crop. Burn stubble, if possible. This may be helped by scattering straw freely over the field. Wrap old sacking about the end of a four-foot stick, dip in gasoline, set on fire and shake on straw and stubble. Carry gasoline in open pail. If stubble is too light to burn, then cultivate, harrow and seed a little lighter than above. Oats and barley will do better than wheat. If shoe drills are used, plow instead of cultivating. Plow, pack or roll, then harrow if land is grassy or weedy. In the drier sections at least one-third of cropping land should be summerfallowed every year."

When the advice of the Federal Department of Agriculture and Finance through their "Thrift and Production" advertisement first appeared, I was thunderstruck by the extraordinarily fallacious nature of it. My first hope was that no one would heed it anyhow. On further reflection, however, when it

occurred to me that some of us in the West are all too prone to careless farming when left to our own inclinations, and that possibly this tendency would become worse if advised in that direction by so naturally accepted an authority as the Dominion Department of Agriculture, I felt it was someone's duty to dissent.

My personal respect for the Dominion Minister of Agriculture, the Hon. Martin Burrell, made the performance of such a duty by myself very unattractive, and indeed quite delicate, as I would be subject to being misunderstood due to the fact that many cannot conceive of such criticism being made from other than political considerations.

When my opinion was asked, however, I concluded the time had arrived for some one to speak out and vigorously protest against the agricultural heresy that is being industriously promulgated by the Federal Department of Agriculture and Finance under the very laudable pretext of "Thrift and Production" during war time. Before entering into the merits or demerits of the advice given in the advertising of the present "Thrift-Production" campaign, by the very unusual means of practising what is "bad and worse" farming, from which most thinking, progressive farmers have been endeavoring to get away, permit me to make some general reference to the well intended "Production and Patriotism" campaign directed from Ottawa which was launched last year. By that campaign we were all invoked to produce by increased acreage. We were at war, the world was at war, therefore production and more production was a prime necessity. And to this general conclusion no one could take reasonable exception. But how is this to be accomplished? "By sowing every acre possible in 1915" so we were told repeatedly. Were not the struggling millions in stricken Europe relying on Canada for bread? Therefore for the sake of the Empire, for the sake of humanity, sow and sow more, and more, and keep on sowing as a patriotic duty, as the last acre might turn the trick.

Now, Mr. Editor, it is good to feel that a young country like ours fills so important a part in the great world upheaval that is now in progress. It is comforting and gratifying to think that we are, in a large part, carrying a staggering, hungry world on our young but sturdy shoulders. We have permitted ourselves to be jollied into thinking that at least our own Empire, if not our Allies, are relying on us for their daily bread. I take it that this pleasant sort of a daydream is not very harmful in itself, but when this mistaken and even presumptive attitude is made the foundation for an urgent patriotic appeal for us to keep on producing by equally misleading and presumptive methods set forth in the Federal advertisements you have referred to, it is time for some one to try at

least to point to saner and more reliable methods.

The "Patriotism and Production" campaign like the present "Production and Thrift" campaign, was based upon the alleged need of our agricultural products to feed the Empire. Our financial needs were barely mentioned as a reason for sowing every available acre. But how many hungry mouths would there be in the other parts of the Empire if Canada had failed last year to produce a single bushel of wheat for export? How many people of the allied nations would miss a meal if Canadian wheat could not be bought? What is our present status as a wheat producing country?

Canada produced in 1915 less than one-tenth of the wheat of the world. Russia produced a billion bushels, more than one-fourth of the world's crop and although this was not available to any of the outside wheat-eating nations, owing to the closing of the Dardanelles, the only effect the withholding of this immense crop had was to stiffen prices, but no one went hungry because of the fact that the Russian wheat was shut in. The United States crop of 1915, consisting of practically another billion bushels, representing a quarter of the world's production—was so damaged by weather conditions that approximately 250 million bushels of it was rendered unfit for human food and was used as stock food. This 250 million bushels of damaged American wheat was nearly as much as the entire exportable surplus of Canada last year, and yet its loss as bread producing food merely stiffened the world prices a little more, but again no one went hungry as a result.

We are justifiably proud of our agricultural achievements and we have full confidence that some day our country will produce, in common with the United States and Russia, a billion bushels of wheat in a single season. But we cannot of course expect to do it now with our present population and marketing facilities.

In the face of the above figures and facts, why longer delude ourselves into thinking that the Allies or even our own armies are dependent on Canada for bread? As a matter of fact, if Canada did not grow one bushel of wheat for export in 1916, it would scarcely be missed in the world's general supply. With Russia shut out of the market, our hard wheat would be missed true, but only because of its quality and not because of its quantity in the general aggregate with such a large world acreage under wheat as we have at present.

Yes, by all means, we require full production, but mainly for financial reasons. But our fullest capacity can only be obtained by farming better and not by farming more. The average man is already spread over too many acres for best results. A full crop from both field and flock will keep the wheels of commerce going, will maintain our credit and enable us to finance the war, will keep our railways and labor busy, will improve municipal and governmental revenues, will liquidate some more of our tiresome debts, will maintain our grip of things and keep the pot boiling generally, but a full crop is required far more for the sake of this part of the Empire, than it is needed for supplying

Continued on page 70



Boy: "Golly, Misier, what bait are ye usin'?"



## Baking Powder

### Scores out FAILURE On Baking Day

—Reliable results always follow the blending of this brand with Western flour.

You will like this recipe:

#### QUAKER MUFFINS

- 2 3/4 cup rolled oats
- 1 1/2 cups flour
- 4 level teaspoons Gold Standard Baking Powder
- 1/2 teaspoon salt
- 1 cup scalded milk
- 1 egg
- 2 tablespoons melted butter
- 3 tablespoons sugar

Turn scalded milk on rolled oats, let stand five minutes; add sugar, salt and melted butter; sift in flour and baking powder; mix thoroughly, and add egg well beaten.

This is only one recipe in our big 110-page Cook Book. Free on request.



Pound Tins

25c.

At Your Grocer's

The Gold Standard Mfg. Co. WINNIPEG

28

### Man's ingenuity is again revealed in

## ADAMS' TUTTI FRUTTI GUM

The former method of hand-wrapping in vogue for thirty-five years has given place to special machine-wrapping which encloses each separate stick in wax-paper and tinfoil. The outer package wrapper is a valuable coupon worth saving for Regimental or College Shield. You can get Tutti Frutti in any of five mellow flavors.

ORIGINATORS

Adams & Sons Co

### RIDER AGENTS WANTED

In every locality to ride and exhibit a 1916 Hyslop Bicycle (same latest improvements).

**10 DAYS' FREE TRIAL**

Every Hyslop Bicycle is sold with the understanding that if owner is not satisfied after using bicycle 10 days he may return it for a full refund of purchase price.

**DO NOT BUY a Bicycle, Tricycle or Sporting Goods until you examine and test Hyslop's and compare with the best.**

**TWO CENTS** send us a postal, and we will mail Free, postpaid, Hyslop's Art Folder showing our complete line of Bicycles, Tricycles, and Sporting Goods. Do not wait. Write today.

Write today.

**HYSLOP BROTHERS, Limited**

Dept. 21 Toronto, Ontario

not wait. Write today.

Dept. 21 Toronto, Ontario

Dept. 21 Toronto, Ontario



# Chiropractic

## WHAT IS IT?

Dr. H. J. MUNRO

### It Means Perfect Health . . . Through Perfect Nerve Action

"If you should have ailments consult a Chiropractor and let him put your Spinal Column in agreement with your nervous economy, so you can be a good automatic engine:" *Elbert Hubbard*

**CHIROPRACTIC** in its underlying principle of perfect health through a perfect backbone, is far from being a new or untried branch of Natural Science brought directly to bear on the restoration of a physically defective system to perfect health. It has been anticipated in many different ways. So long as a hundred years ago some German doctors discovered that in almost every disease there was a fault in the alignment of the various portions of the backbone. These single bones are called vertebrae, and there are thirty-three of them—twenty-six of which are movable—and they altogether make up the spinal column. The single bones, or vertebrae, are ring-like and placed on top of one another. Now these thirty-three ring-shaped vertebrae, with their many little peculiar elevations and depressions, form the wall or tube which encloses the great conduit or passage-way of nerves. Taking them altogether, these nerves make up the spinal cord, and from this cord, which is a direct continuation of the brain, the individual nerve fibres emerge on each side of the various rings or vertebrae of the entire backbone, and carry their life-giving and health-maintaining energy to all the vital organs, muscles and bones.

Now, having clearly in mind the architecture of this spinal column for a moment, it will be seen how easily one or the other of these movable vertebrae can "slip" a little one way or another,

and how liable to injury most of these thirty-one pairs of spinal nerves must be as they pass between these movable bones of the spinal column. And this is precisely what happens in hundreds and thousands of people every day.

**CHIROPRACTORS** call these slips "Subluxations." These subluxations may occur through jars, wrenches, strain, improper poise, drafts, colds, mental excitement, depression, inherited weakness, overstretching of the muscular bands or ligaments and muscular contractions resulting from infectious diseases and poisonings, and from a hundred and one incidental and accidental causes.

When the nerves are pinched or pressed upon, the nerve current must become restricted, and disease is the result. Pains about the head, face, eyes, neck, back or limbs; diseases of the stomach, heart, lungs, liver, kidneys, bowels or special organs of sex; paralysis, catarrh, rheumatism, gall stones, neuralgia, lumbago, asthma, goitre, lowered vitality, irritability, insomnia; all these and many other ailments have yielded to Chiropractic adjustment when everything else has failed, and all simply because the nerve pressure was relieved. Many surgical operations can be avoided by Chiropractic adjustment, and the old-time methods of drug treatment are becoming more and more a thing of the past.

My Profession is based on an Exact Science, not Guess Work, nor is it necessary to Change Your Religious Beliefs to have Perfect Health through Chiropractic.



**NURSE MOWBRAY**—a lady of great experience in the treatment of all manner of ailments, was herself a sufferer for 16 years from Gall Stones. During that period she endured almost continual pain with very severe recurring attacks particularly during the last two or three years of her sickness. After six weeks under the simplest Chiropractic adjustment she obtained perfect freedom from this terrible malady. **THE CANADIAN THRESHERMAN AND FARMER** has taken the opportunity for its own protection to personally interview a number of Dr. Munro's cases and can vouch in unqualified terms for the remarkable success he has achieved in these particular instances. Dr. Munro's position towards the patient is **NEVER A DOUBTFUL ONE**. His consultations are **FREE**. If he does not believe he can succeed, he will not undertake the case. If he does proceed and is perfectly successful, his charges are what the poorest patient can have no difficulty in meeting. If he does not completely satisfy the patient—he will have done no harm and **THERE WILL BE NOTHING TO PAY**.

The following are several of the most prominent diseases the cause of which can be removed by Chiropractic adjustment:—

- |                  |              |                           |                     |                 |                   |
|------------------|--------------|---------------------------|---------------------|-----------------|-------------------|
| Abscesses        | Cancers      | Epilepsy                  | Headache            | Kidney Diseases | Pneumonia         |
| Anaemia          | Catarrh      | Eruptions                 | Heart Disease       | Lung and Liver  | Rheumatism        |
| Appendicitis     | Constipation | Eye Trouble               | Hemorrhoids         | Trouble         | Sciatica          |
| Asthma           | Convulsions  | Female Diseases           | Indigestion         | Lumbago         | Spinal Meningitis |
| Bladder Trouble  | Deafness     | Fevers (Typhoid included) | Infantile Paralysis | Nervousness     | St. Vitus Dance   |
| Bronchitis       | Diabetes     | Gall Stones               | Insanity            | Neuralgia       | Tumors            |
| Bright's Disease | Diarrhoea    | Goitre                    | Insomnia            | Paralysis       | Vertigo           |
| Biliousness      | Diphtheria   |                           | Jaundice            | Pleurisy        |                   |

**A CHIROPRACTOR** secures his education in much the same way as any practitioner. The training is complete in every detail.

**I AM** a graduate of the **NATIONAL SCHOOL OF CHIROPRACTIC** which is a guarantee of efficiency—a basis for absolute confidence.

**THE** patients I have helped are the best recommendation of my ability to aid you even after medical practitioners have given up your case as hopeless.

If you are living at a distance—write me the briefest details of your trouble. If you can conveniently call, so much the better. **THERE IS NO CHARGE FOR A TALK WITH ME. YOUR HEALTH IS SURELY WORTH A FEW MINUTES' CONSULTATION. HUNDREDS OF GRATEFUL PATIENTS WOULD BE GLAD TO TELL YOU WHAT I HAVE DONE FOR THEM.**

**Dr. H. J. MUNRO 31 Steele Block Winnipeg, Man.**  
Phone Main 234

**AN OPEN LETTER**

Continued from page 68

any other particular country with bread, even in times like these. In the face of these facts then what regrettable folly it is for the Federal Government, under the plea of patriotic food necessities, to advise the Western farmer to sow his land three seasons in succession without plowing? True, certain portions of Saskatchewan had practiced for many years and to advantage, the sowing of burned fallow stubble land. But this is only in limited areas and is being gradually discontinued owing to the consequent introduction and entrenchment of such perennial weeds as Canada thistles, sow thistles, quack grass and other perennial pests. But to be advised to sow three successive crops without plowing or distinction as to soils, previous tillage districts or even provinces, is little short of madness, especially at a time when we should all do our best and not our worst. That such erroneous advice should come from so eminent a source is extremely regrettable on account of the fact that thousands of men who are farming in Western Canada have had only limited experience of the conditions peculiar to agriculture in the prairie provinces and are naturally liable to accept such advice as reliable. For the sake of such I protest. Men with longer experience will readily see the fallacy of such misleading advice.

The best informed Saskatchewan farmers will put into wheat this spring what can be put in properly and in time. As the spring is little late, a certain additional element of chance will have to be taken in the later districts, but there will be no disposition to go on blindly sowing wheat after the date when experience in each particular district has proven it to be unwise to do so.

Nor will they sow to wheat or anything else third crop stubble or even much second crop stubble after coxing

**THE "LEADER" LINE OF Ornamental Fence**

Made of Heavy Galvanized Steel Wire in many strong and handsome designs, suitable for lawns, driveways, etc. Moderate in price and guaranteed to give perfect satisfaction.

We also manufacture a full line of Walk and Drive Gates, fitted to match any design of fence selected.

Write for Catalogue and full particulars

**The Manitoba Anchor Wire Fence Co., Limited**  
Makers of the "Leader Lock" Farm Fences  
Cor. Henry Ave. and Beacon St. - Winnipeg, Man.

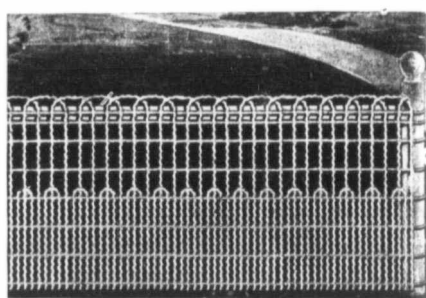

Style "H"—Chicken-proof Wire Fence

it to burn with a top dressing of gasoline as advised in the first advertisement of the "Thrift and Production" campaign, but they will shallow plow such land and if too late for wheat they will sow with coarse grains as the district and the particular farm or the farmer's inclination may suggest. After the sowing of all commercial grains has been completed, say June 1, indications point to the likelihood of a still further acreage being spring plowed and sowed with oats for sheep feed, should it not ripen fully, or for commercial use, should the fall be open like last year and maturity ensue.

Doubtless also in the flax growing areas, especially in Western Saskatchewan, where the fall frosts are usually later, this profitable crop will be more extensively sowed than last year, notwithstanding its predisposition to be weedy, using spring plowed stubble rather than spring breaking up till the first week of June. Farmers who have been following a three-year rotation—two crops and then fallow—and this is the general practice on the open plains, follow the advice of the Federal Government this year and sow a third crop on stubble, they will not only run the chance of reaping mighty scantily, but after putting all their land in crop they will have no land left to summerfallow for next year's crop and next year with its requirements will likely come around. Our fallow system must under no consideration be departed from, even though the advice comes from the wise men of the east, as this is the only known and well-proven method whereby the fullest production can be secured and maintained.

I do not know what evil genius has prompted the Departments of Finance and Agriculture at Ottawa to hand out to Western farmers such ill-timed and illogical advice; but let us hope that comparatively few will be misled by it. Certain it is it did not emanate from such worthy agricultural war horses as Prof. Bedford and our own Angus MacKay, nor from any Western provincial agricultural college or other provincial authority.

So much for the "Production" campaign. Now just a word about "Thrift." There has just come to this office a large poster bearing the name of Sir George Foster, Minister of Trade and Commerce, advising us to save up our old rags. Possibly the Honorable Minister of Trade and Commerce has had a sort of intuitive premonition that if we follow the advice of his well-intentioned colleagues, the Ministers of Agriculture and Finance, we shall ere long have little else but rags to save, hence the suggestive and somewhat ominous advice—"Save your rags."

The writer regrets the necessity of speaking thus plainly, but when the blind undertakes to lead the blind in matters agricultural in this province, it is time for some one to speak out and warn the unsuspecting and inexperienced settler lest he also tumble into the ditch. —Yours very truly,

W. R. MOTHERWELL  
Regina, Sask., April 20, 1916.

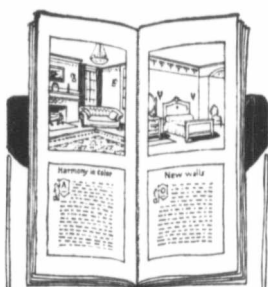

**Going to Decorate?**

If you are going to "do" the dining-room or the bedroom, or even the kitchen, this spring, you need this book. It illustrates in photogravure, in colors, rooms done with Alabastine. It contains suggestions and ideas for color schemes, and it shows how you can do the work yourself.

**Alabastine Artistic Wall Tints**

A copy of "Homes Healthful and Beautiful" costs but 15c. (coin or stamps), but if it saves you from making even one mistake—and there is nothing easier to make than mistakes in color—will it not pay for itself a hundred times over? Then send for it now and study it before you start housecleaning.

THE ALABASTINE COMPANY LIMITED  
66 Willow Street Paris, Ontario

**A DAILY DELIGHT**  
IN THE COLD WEATHER.  
It isn't the cost of a furnace that counts, it's the satisfaction you get in heating your home comfortably and economically.

**HECLA WARM AIR FURNACE**  
heats any house thoroughly and saves one ton of coal in every seven used

Write for our booklet "Comfort & Health"

**CLARE BROS. WESTERN LTD. WINNIPEG, MAN.**

Tear off COUPON CLARE BROS. WESTERN LTD. DEPT. WINNIPEG, MAN. Please send me Illustrated Booklet COMFORT and HEALTH Name \_\_\_\_\_ Address \_\_\_\_\_

**Course of Better Farming**  
Continued from page 58

graded for shipment, or preserved for use in winter. The time will be devoted to short talks on various poultry topics and to demonstrations of candling and the commercial grading of eggs.

**Household Science Section**

Mrs. Raymond Archibald of Saskatoon who will be in charge of the Household Science Car was formerly Miss Jean McPhee, one of the first graduates from Macdonald Institute, Guelph, Ontario. She will give practical demonstrations and lectures on Cookery in the Household Science Car, in which she will be assisted by Miss Asther Thompson, who was last year's Gold Medallist of Manitoba College. Mrs. Sarah Dracox of Paynton and Mrs. Peter Yemem of Theodore it is expected will lecture along other lines of vital interest to the women.

**Boys' and Girls' Section**

Professor Fred W. Bates, B.Sc., Director of School Agriculture for northern Saskatchewan with headquarters at Saskatoon will be in charge of this section. Lectures illustrated by lantern slides will be given on such topics as Birds and

Insects Native to Saskatchewan; Noxious Weeds of Saskatchewan, etc. The boys' and girls' car will have many interesting exhibits. The lecturers will include Mrs. W. W. Tomson, Regina, who was in charge of this department the train last year; J. G. Rayner, B.S.A. North Battleford, W. W. Tomson, B.S.A., Acting Weeds and Seed Commissioner for Saskatchewan.

**Nursery Car**

A car prepared for the entertainment of small children was a feature of the train last year and will be continued this year. A wonderful sand pile, a collection of brightly painted toys, and a very entertaining slide are features that will help to make the time pass pleasantly while the parents attend the lectures in different parts of the train.

Miss J. Gillespie and Mrs. L. E. Kirk who were in charge of this section of the train last year have consented to assist again this year.

We regret space is not available for many interesting details furnished us in addition to the foregoing particulars. The itinerary starts at Langham and Borden on Monday 12th June and finishes at Alasko on July 14th.

M  
I w  
much  
of the  
cently  
that v  
in pa  
of fau  
fault  
looked  
this h  
found  
fathers  
to sta  
make a  
and vo  
ing vo  
studies  
fert.  
While  
ter I r  
criticiz  
ter the  
me expt  
for the;  
sons an  
did men  
ism has  
then of  
remarks  
who ma  
reason I  
This wa  
to create  
letters t  
I have be  
I feel  
ing is ne  
age of o  
A yom  
of ambli  
a few mo  
to run i  
"When f  
right. He  
Just love  
most of  
from mor  
it any lo  
I asked  
more than  
She rep  
nurse. Fr  
everything  
I felt th  
of vitality  
she would  
asked: "If  
pital work  
The expi  
mediately  
talked for  
she went h  
consent of  
to take he  
the other h  
as she liked  
to her hom  
for a while  
me rap. Si  
attack on th  
so hurt an  
little soul y  
When she d  
as if I were  
face was full  
of fault find  
passion wink  
I explained i  
arms and sh  
of self-contr  
shrieked: "N  
the kind. Sh  
she slammed t  
week the gi  
and where is  
The followi  
recently appe  
My own de  
the homesom  
was always s  
taught me to  
Bible to me.  
There was  
the sunshine  
wedding. Oh,  
daddy-to-nigh  
hundreds of  
world, and we  
It's always th  
the fathers, an  
too. I am so  
What shall I  
"How is you  
de Henry?"  
"Well, I dur  
slow. I do wis  
thin."—Puck.

FATHER'S CORNER

I wonder if we neglect "Father" too much. "Mother" seems to come in for all of the praise. One correspondent recently wrote this department saying that women air their domestic difficulties in papers; blaming men for all kinds of faults; but you never find men finding fault with their wives in the press. I looked over many papers after receiving this letter and in the correspondence found so much fault finding with the fathers of families that I determined to start a Fathers' Corner. You cannot make a house white by painting it black, and you cannot throw mud without soiling your fingers. The successful artist studies perfect models—not the imperfect.

While in a group of women this winter I made the remark that we were criticizing men too much to-day and after the meeting several women came to me expressing gratitude for the remark, for they said they had husbands and sons and fathers that were noble splendid men and much of the recent criticism has made them resent it. Since then other women have made similar remarks. Just because there are men who may not be fair is not sufficient reason for bitter attacks on all men. This wave of criticism has a tendency to create "manhaters." I have received letters this winter from women who have been so influenced against all men.

I feel that old-fashioned home-making is needed as much to-day as in the age of our mothers.

A young seventeen-year-old girl full of ambition and adventure came to me a few months ago. She was determined to run away from home. She said: "When father is home everything is all right. He is such a good fellow and I just love him, but he is on the road most of the time and mother scolds from morning till night. I can't stand it any longer."

I asked her what she wanted to be more than anything else in this world. She replied: "I would like to be a nurse. From a child I have bandaged everything I could find."

I felt that with her unusual amount of vitality and general appearance that she would make a good nurse. So I asked: "If I try to get you into a hospital would you consider it?"

The expression of her face was immediately transfigured into joy. So we talked for a while on the matter and she went home happy. I finally got the consent of a children's hospital matron to take her as she was too young for the other hospital and she was pleased as she liked children. Then when I went for a while as the mother did not hear me rap. She was commanding a fierce attack on the family in general, in tones so sharp and loud that I am sure each little soul was pierced to the heart. When she did come to the door I felt as if I were facing a female demon. Her face was furrowed with the habitual lines of fault finding. Eyes fierce with mad passion winked fast with disapproval as I explained my mission. Nerves in her arms and shoulders twitched from lack of self-control. When I had finished she shrieked: "No! she can do nothing of the kind. She's got to mind me!" And she slammed the door in my face. The next week the girl ran away from home—and where is she to-day?

The following letter from another girl recently appeared in a paper:

"My own dear daddy died, and I am the lonestomest woman to-night. For he was always so kind and good to me. He taught me to pray, and he read the Bible to me.

There was no day but mother killed the shunshine in the home — slamming scolding. Oh, how I want to see my daddy to-night! Mr. Editor, there are hundreds of patient daddies in this world, and we don't love them enough. It's always the mothers eulogized, never the fathers, and they need to be praised, too. I am so lonesome without mine. What shall I do to find peace?"

"How is your wife this morning, Uncle Henry?"

"Well, I dunno. She's fallin' dretful slow. I do wish she'd git well, or somethin'."—Puck.

# A range you can easily control



It is wonderfully simple and easy to regulate both your cooking and the expenditure of fuel,—money. And easy to manage, means easy to economize, you know.

All the Kootenay controls are on the outside. For instance, how infinitely easier to control the damper from the front of the stove—the Kootenay way—

than to bend over the hot top to reach it! Surprising how quickly one gets almost complete control of every bit of heat, making it do your bidding. You keep an eye on the thermometer, and the smokepipe fuel saver, handy dampers, and on the oven that loses no heat; all work together for splendid cooking at least expense.

You want to know about the sensible ideas for saving time, the fine bakings you can do with a small amount of fuel, and the way the range withstands the wear and tear that wrecks ordinary ranges; its aluminized flues mean long life to the range because the coated steel linings are rust-proof; asbestos joints prevent leakage of air at joints.

## McClary's Kootenay Range

The new booklet, just off the press, tells everything in an interesting way. Tear out the coupon and send it to the factory. Before you forget, and certainly before you buy a range, get your copy.

### McClary's

London Toronto Montreal Winnipeg  
Vancouver St. John Hamilton Calgary  
Saskatoon Edmonton

871

Tear off this Coupon

Kindly send me a copy of your booklet about the Kootenay Range.

Name.....

Address.....

A WOMAN'S TALK TO WOMEN

(Continued from page 60.)

would seem that the little red school house is doomed. It must go, and possibly the one teacher, for all subjects, and possibly, the stiff rows of desks, and the dry arithmetics, and the readers, first, second, third and fourth.

In this change there is one thing needed and badly needed, and that is the woman's viewpoint. Our whole educational system has been built on the viewpoint of one sex. This, despite the fact that the Creator made it necessary for every child to have two parents, a father and a mother. So far in our march toward civilization we have always found that the closer we keep to nature, the more near we are to the truth.

In order to have the viewpoint of the women expressed in our education, it will be necessary to have women on our school boards, and more than that; it

will be necessary for the women, the mothers and the friends of the children, to take an intelligent and kindly interest in the schools. I have said before that when I was a teacher, I never had a parent visit the school unless to criticize. A parent, bobbing over the hill, meant trouble, and most teachers in country schools can tell you the same. And many a teacher could tell you that a sympathetic visit from the parents, with a heart to heart talk about the needs of their children, would help the teacher and the pupils, and the parents. The teachers do not pretend to be infallible or if they do, it is because they are afraid. Parents should not expect the teacher to be perfect and wait with traps to catch him or her. I remember one school in which I taught, a bright young man had a few catch words in spelling, that he used to spring on the teacher when there was a crowd around. Now take my word for it, there are many clever people who

make mistakes in spelling. Yes, we all make mistakes in something. If we didn't, we would be much too valuable to spend our time teaching school, at forty, or fifty, or sixty, or even one hundred per month.

Prisoners in Germany

We are all very much interested in any account of the boys who have been taken prisoners. The best account that I have heard was that of Sergeant Wells, who brought the official moving pictures of the Canadian troops. You may have read an account of him, but I did not see in the paper the account of his time as a prisoner.

He confessed quite frankly that the first time he was under fire he was too frightened to move. But like everything else, one gets accustomed to it. He was taken prisoner after he had been shot many times. He said that the German doctor told him he could not live, but a

ay, '16



ited Man.

T n's your

E

TD MAN MAN LTH

chewan; tehewian, car will exhibits. Mrs. W. was in the train B.S.A. Tomson. id Seed hewian.

tertains a fea- and will wonder- bright- v enter- hat will s pleas- end the of the

s. I. E. of this ar have is year. railable its fur- fore inary- den on shes it



**The Happy Baby**

The air of perfect happiness and contentment of babies brought up on Savory & Moore's Food is constantly a subject of remark. This is simply because it is so easily digested, so nourishing and satisfying, in fact an ideal food for babies in every way.

Get a tin of Savory & Moore's Food to-day from your Stores, and note how eagerly baby will take it, and what marked improvement and steady progress will follow its use.

**MOTHER'S GUIDE FREE**

Savory & Moore's little Book "The Baby," is full of useful and reliable information on Infant Management. It is just what a young mother requires, and will prove invaluable in the home. A Free Copy may be obtained on application to Savory & Moore, P.O. Box 1601, Montreal.



**The Correct Thing**



**Beautiful Silk and Gretone Shades**

We have a beautiful line of dainty designs and beautiful color creations with or without High - Class Pedestals.

Ready for use All sizes at prices to suit every purse. We have small lamps with 10-inch shades complete from \$3.50 in any finish.

Send us your order. Write for our illustrated booklet with prices and make your selection.

**TORONTO SILK SHADE CO., 370 Victoria St.**  
Manufacturers of Candle, Lamp and Electric Light Shades  
**TORONTO**

**BETTER BABIES**



Worth its weight in Gold

Every Young Mother and Expertist Mother that has her Baby's welfare at heart, should have a copy of DR. TWEDDELL'S Young Mother's Guide. It tells all about Baby, its care, needs, and diet, and how to keep Baby well and strong.

DR. TWEDDELL is considered one of the foremost Child Specialists of today. His advice to Young Mothers given in this little Guide is well worth many times the price asked for it. For Baby's sake, WRITE TO-DAY FOR A COPY. Simply enclose a one dollar bill in an envelope, giving name and address, and mail same at our risk, with the understanding that if you are not well satisfied with this valuable little Guide you can return it at once and we will refund your money. Don't delay. Do it now. Not sold at stores. Just address NIGHTINGALE & THE ASSOCIATION, Dept. P., 300 Eglie Bldg., TORONTO, ONT.

**BOOK ON Dog Diseases and how to feed**  
**H. CLAY GLOVER, V.S.**  
118 West 31st St., N. Y.

Mailed free to address by the author.

Belgian nurse who was caring for him, told him that she would pray for him, and he must pray for himself, and she was sure the good God would spare his life. She knelt beside his bed, and holding a cross, prayed for him, and who can say that her prayers did not help him.

He was finally taken into Germany, minus an arm, and with a plate in his side, but alive and getting better. He said that he knew there was no chance of being exchanged, for that luxury is kept for officers and those who go insane. He could not be an officer, so he decided to pretend to be insane. He did so, and all day went around pretending to ride a horse. He was finally put in with a number of insane Russians, and then, with "mentally deficient" written on his clothes, was sent back to England. He said it was easier to persuade the German doctors that he was insane, than it was to make the English doctors believe that he was not.

But what I wanted to say was that he begged all those who could do so, to send food to the prisoners in Germany. He said the food given prisoners there is not of a kind that they like; in fact it is very distasteful to them, and one can scarcely imagine the joy of the poor privates when they get a parcel from home. The German guards get just the same food as the prisoners and they are hungry, too. Often the prisoners give their guards a bit from the home parcels, they look so longingly at the good things to eat.

Sergeant Wells said that the parcels sent are delivered to the prisoners, so there need be no fear on that score. He urged that instead of sending so much to the men in the trenches, where they have good fare, more should be sent to the poor fellows who are prisoners and must remain so until the war is over.

What a lot of needs there are these days. We cannot hope to do all that should be done, but folks' hearts are very big, and wonderful things are being accomplished. It seems that those who are doing the most can still do more. The prairie is wide, with great stretches of land and sky, and big are the hearts that are building it into a nation.

**DID YOU GET YOUR FREE COPY OF THE GOLD STANDARD COOK BOOK?**

Now that spring is really here and summer just ahead, the Ladies of Winnipeg and the West are looking up their recipes for easily made hot weather dishes. Many house wives have been using the same old desserts and puddings and jellies and cakes month after month simply because the old recipes hold good and forgetting that many new ones are just as good.

The pure products manufactured by The Gold Standard Manufacturing Co., Winnipeg, are commanding a great deal of attention and giving splendid satisfaction and those who have not tried them have a treat in store for themselves and their families.

The Gold Standard people publish a beautiful, illustrated cook book containing 110 pages. Its 19 chapters contain 268 recipes for the making of Bread, Biscuits, and Rolls, Muffins and Gems, Griddle Cakes and Waffles, Cookies, Doughnuts, Cakes, Pies and Fritters, Puddings, Pudding Sauces, "Just a Minute" Puddings, Quickly Prepared Desserts, Frozen Desserts, Miscellaneous Recipes, Sandwiches and Salad, Cheese, Vegetables, Game, Fowl, etc., Eggs, Fish and Soups.

Besides these are Helpful Hints (3 full pages) letters of appreciation and a complete list of the Gold Standard Products.

Taking this Cook Book from cover to cover, it is a splendid work and one which should be on every pantry shelf. It is free for the asking. Better write for one now while you have it in mind. Just address: The Gold Standard Manufacturing Co., Winnipeg, Canada.

**WOMEN AND THRIFT**

Upon the women of the land will rest the greatest burden of success in the campaign for thrift that has been inaugurated. As heads of the household they are the chancellors of domestic exchequers. It is for them to bear in mind that expenditure upon articles that are not actually needed is not alone lessening their own resources but also depriving the country of something that might be more profitably applied.



**The Autocrat of the Breakfast Table**

of the Tea Table, and, in thousands of homes, of the Dinner-Table, too, is

**BLUE RIBBON TEA**

And why?

Because Blue Ribbon Tea is a delightful beverage—healthful—mildly stimulating—pure as the Western breezes—and almost as cheap.

Drink Blue Ribbon Tea for your health's sake. Buy it for your pocket's sake.

And note the new package—a perfect protection against the enemies of good tea—dust and moisture.

**A money-back guarantee goes with each packet. Ask your Grocer**

**The "Florence Kitchen"**

Makes the happy family. McClary's Florence Blue Flame Oil Stoves simplify your cooking. Easy to use, clean, safe, economical, and reliable—an ornament to any kitchen.

**McClary's FLORENCE OIL COOK STOVES**

No hot summer kitchens. The Florence is ALWAYS ready with AS MUCH heat as you want, right WHERE you want it—in the cooking, and NOT out in the room. Costs less than a cent an hour per burner.

You can keep one—or four—burners at an intensely hot flame, or merely simmering. To regulate the heat, you simply turn the lever according to the dial.

There are no wicks to trim, nor valves to leak. The oil supply is automatically constant. All Florence stoves and ovens are fully guaranteed.

Ask your dealer to show you the Florence. If he cannot supply it write to our nearest branch.

London Toronto Winnipeg Vancouver St. John, N. B. Montreal Hamilton Calgary Edmonton Saskatoon 825

**The Report for 1915**

of The Great-West Life Assurance Company is now in print and will be mailed to any interested person on request.

It records a year of remarkable success—success founded upon twenty-three years of remarkable

**Results to Policyholders**

Over \$119,000,000 of Insurance is now held in force

by

**The Great-West Life Assurance Co.**

HEAD OFFICE - - WINNIPEG

The 1 victims are alv. suspicio

CA We Zinc, Rags, Boots Thon JUNI Print

WOO If you and m Hides, FR.

PAI Write for FETE FRED. B. GER 36-37 Can

William E. KNOWLI BARR Imperial Canada Western Office MOOSE

\$120,0 Space time may INTERNATIONAL B





The man who speaks his positive convictions is worth a regiment of men who are always proclaiming their doubts and suspicions.

**CASH FOR TRASH**

We buy Old Brass, Copper, Zinc, Lead, Auto Tires, Bones, Rags, Tailors' Clippings, Rubber Boots and Shoes, Hides and Furs

Write for Quotations  
**Thompson Commission Co.**  
JUNK HIDES FURS  
Corner Princess & Alexander WINNIPEG

**WOOL FURS HIDES**

If you want quickest returns and most money for your Furs, Hides, Wool, etc. ship them to

**FRANK MASSIN**  
BRANDON, Man.

Write for Prices and Shipping Tags

**PATENTS TRADE MARKS AND DESIGNS**

Write for booklet, circulars, terms, etc.  
**FETHERSTONHAUGH & CO.**  
Solicitors for  
FRED. B. FETHERSTONHAUGH, K. C. M. E.  
GERALD S. ROXBURGH, K. A. S. C.  
36-37 Canada Life Bldg. WINNIPEG

William E. Knowles J. Franklin Hare  
A. Benson, B.A.

**KNOWLES, HARE & BENSON**  
BARRISTERS, SOLICITORS, ETC.  
Solicitors for  
Imperial Bank of Canada  
Canadian Mortgage Association  
Western Canada Mortgage Company  
Offices: Walter Scott Building  
Suite 409  
MOOSE JAW, SASK., CANADA

**\$120.00 SURE**

Congenial work at home among church people. Man or woman. 60 days or less. No experience required.

INTERNATIONAL BIBLE PRESS, Spadina Avenue, TORONTO

The majority of men will agree that so far as the household is concerned their women are pretty thrifty. But stinginess, parcimoniousness, or miserliness is not thrift. The thrifty woman combines with a natural aptitude for economy the wisdom of selection and utilization. She knows when to save and when to spend. She knows what is necessary and what can be done without and she makes the best use of everything. Neither does she do all things herself. When help is at hand she utilizes it with discretion.

The great aid to thrift is thoughtfulness. In fact without that element thrift is utterly out of the question. The thrifty woman, too, not only exercises wisdom herself but sees that her children do the same thing not by indulging them but by delegating to them sundry offices of which they are capable, by making them self-reliant.

But the woman cannot do all these things by herself. She must enjoy the support, countenance and influence of her menkind. The greatest enemy to thrift is the promiscuous doling out of the money. It is not to boys and girls a sign of good nature; it is death to the recipient. It poisons their disposition and sows seeds of weeds that can never be eradicated.

For that sort of thing women are but little responsible, but where their efforts shine is in allowing nothing to go to waste, in making use of everything, and in exercising ingenuity in food, dress, household labour and the bringing up of children.

An incentive to the accomplishment of these thrifts is a reflection upon the times, upon the needs and experience of their male relatives at the front, and upon the fact that every ounce saved is a contribution to the welfare of the country and perhaps to winning the war.

**ON READING THE PAPERS**

"There are many people who jeer at the infallibility of the Pope, but find it quite easy to believe in the infallibility of the newspaper," says the New Statesman.

"Not that they are willing to take the word of any paper at random. Just as there have been occasions in history when men have had to make up their minds between a choice of Popes and among a mixture of rival Roman emperors, so the average man takes his stand by some one paper, and regards the rest as no better than literature. He may choose the Times, or the Daily News, or the Skibberen Eagle. Whichever of them he gives his faith to, he will before long find himself bound to it as though it were his religion or his belief in the Bank of England.

"He thinks of the editor as one who lays down the law after having been in conference with the Almighty. He accepts each paragraph in the remotest-corner of the paper as though it bore the signature of Moses. He would regard a peep at the editor's chair, even when it is empty, as an exciting experience; so great a man as Emerson seems to have felt some of this worshipping's curiosity when he was shown over the Times office. He regards the editor as one from whose brain the journal springs forth each morning perfect and fully-armed. That is why it hurts him, till he groans, when he finds his paper apologizing for some blunder or exaggeration. His faith is a faith in verbal inspiration, and, if this goes, he feels the ground sliding from under his feet.

"What alarms the imagination is the thought of all those millions of readers who have an indigestible mayonnaise of contents served up to them with their breakfasts every day in the papers. They receive a thousand shallow impressions, but scarcely any knowledge. Their reading is a fumbling among mysteries, a reinforcement of a few pet prejudices, an acceptance of the gospel for the moment.

"Even so, however, it is legitimate to cheer ourselves with the reflection that the level of the intelligence of ordinary citizens is rising, whatever may be true in regard to politicians and journalists. But even intelligence does not prevent men from inclining to believe what they see in print. The mesmerism of the printed word subdues workmen and Cabinet Ministers alike."

The Virtue of the Natural Leaf is perfectly preserved in the sealed

**"SALADA"**

packet. Young tender leaves only, grown with utmost care and with flavour as the prime object, are used to produce the famous Salada blends.



In scrubbing floors  
**Old Dutch**

makes the brush go a lot easier



**SILKSTONE your Walls and Ceilings**

Sanitary walls and ceilings, tastefully soft in finish and without gloss, are no longer an expensive luxury. Choose a permanent coating that can be washed with pure soap and water. Twenty-five handsome shades of

**SILKSTONE Flat Wall Colours**

make possible any decorative scheme desired. A beautiful, lasting background in keeping with any furniture. The *Silkstone* agent will tell you all about it.

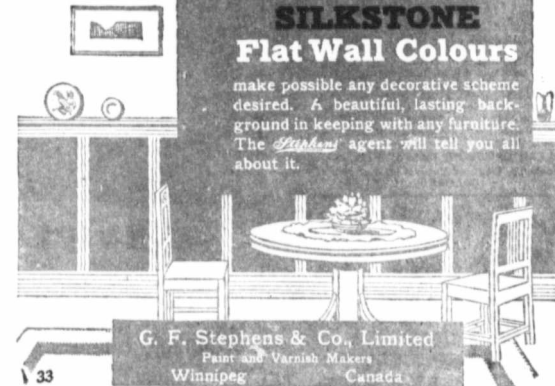

G. F. Stephens & Co., Limited  
Paint and Varnish Makers  
Winnipeg Canada

33

Twelve Months of this Magazine for \$1.00

**STOVEL COMPANY**  
LIMITED  
The High Class . . .  
**Engravers**  
WINNIPEG PHONE G 1609



**SYNOPSIS OF CANADIAN NORTHWEST LAND REGULATIONS.**

**THE** sole head of a family, or any male over 18 years old, may homestead a quarter-section of available Dominion land in Manitoba, Saskatchewan or Alberta. Applicant must appear in person at the Dominion Lands Agency or Sub-Agency for the District. Entry by proxy may be made at any Dominion Lands Agency (but not Sub-Agency), on certain conditions.

**Duties**—Six months residence upon and cultivation of the land in each of three years. A homesteader may live within nine miles of his homestead on a farm of at least 80 acres, on certain conditions. A habitable house is required except where residence is performed in the vicinity.

In certain districts a homesteader in good standing may pre-empt a quarter-section alongside his homestead. Price \$3.00 per acre.

**Duties**—Six months residence in each of three years after earning homestead patent; also 80 acres extra cultivation. Free-emption patent may be obtained as soon as homestead patent, on certain conditions.

A settler who has exhausted his homestead right may take a purchased homestead in certain districts. Price \$3.00 per acre. **Duties**—Must reside six months in each of three years, cultivate 80 acres and erect a house worth \$300.

The area of cultivation is subject to reduction in case of rough, scrubby or stony land. Live stock may be substituted for cultivation under certain conditions.

W. W. CORY, C.M.G.,  
Deputy of the Minister of the Interior.  
N.B.—Unauthorized publication of this advertisement will not be paid for.—64388.

**Well Drills**  
For Drilling  
**WELLS or BLAST-HOLES**  
Built to stand up under heavy work. Most economical and rapid drills made. Styles and sizes for all purposes, with or without power.  
Write for Circular  
**WILLIAMS BROS.**  
428 West State Street, Ithaca, N.Y.

**Get a Farm of Your Own**  
**TAKE 20 YEARS TO PAY**  
The land will support you and pay for itself. An immense area of the most fertile land in Western Canada for sale at low prices and easy terms, ranging from \$11 to \$30 for farm lands with ample rainfall—irrigated lands from \$35. Terms—One-twentieth down, balance within twenty years. In irrigation districts, loan for farm buildings, etc., up to \$2,000, also repayable in twenty years—interest only 6 per cent. Privilege of paying in full at any time. Here is your opportunity to increase your farm holdings by getting adjoining land, or secure your friends as neighbors. For literature and particulars apply to  
**ALLAN CAMERON, General Supt. of Lands,**  
Desk 17, Dept. of Natural Resources, C.P.R.,  
**CALGARY, ALTA.**

**HAWK BICYCLES**  
An up-to-date High Grade Bicycle fitted with Roller Chain, New Repairs or Accessories—Coaster Brake and Hubs, Detachable Tyre, high grade equipment, including Mudguards, Pump, a Tool \$22.50  
Send for **FREE 1911 Catalogue,** 60 pages of Bicycles, Sundries and Repair Material. You can buy your supplies from us at Wholesale Prices.  
**T. W. BOYD & SON,**  
27 Notre Dame St. West, Montreal.



Conducted for the benefit of Dealers, Threshermen and Farmers who have anything to sell or exchange. Five cents a word for each insertion.

**FOR SALE.**  
Second hand rebuilt machinery at our Winnipeg Branch, consisting of:  
Steam engines of all sizes, both traction and portable:  
Gas and oil engines, also  
Second hand rebuilt separators.

If you are looking for second hand machinery, it will pay you to get in touch with us. We can save you money. Our machinery is rebuilt in our own shops by competent workmen. We have a bargain for you. For particulars, address:  
**J. I. CASE THRESHING MACHINE CO.,**  
Princess and James Streets,  
Winnipeg, Manitoba.

**FARMS WANTED**—We have direct buyers. Don't pay commissions. Write describing property, naming lowest price. We help buyers locate desirable property. Free. American Investment Association, 15 Palace Bldg., Minneapolis, Minn.

**WANTED**—Good threshing outfit for my \$1,500 equity in St. Charles Winnipeg lots. G. S. Gudmundson, Framnes, Man.

**O.A.C. No. 72 OATS**—The great new oats introduced by Ontario Agricultural College. The greatest oats for yield and quality ever introduced into the West. We have the genuine article grown from registered. Price 75c per bushel. Eureka Pedigreed Seed Farm, Melita, Man.

**FOR SALE**—Automobile, 35 H.P. Russell Roadster, in excellent condition. Newly painted and overhauled. Complete with top wind shield, speedometer and two extra tires. Price \$300.00 cash. F.O.B. Winnipeg. Address H. Box 3164, Winnipeg, Canada.

**IMMORTALITY CERTAIN**—Swedenborg's great work on "Heaven and Hell" and the life after death, over 400 pages. Only 25c, postpaid. W. N. Law, 486-G, Euclid Ave., Toronto, Ont.

**A GENUINE SNAP**—FOR SALE OR EXCHANGE—1 Reeves 25 h.p. cross compound engine, rocker grates and extension wheels, in good repair; 1 Reeves 40 h.p. separator blower, feeder, high bagger. This outfit can be seen at Indian Head, Sask. For price apply to F. E. Campkin (agent), Indian Head, Sask.

**FOR SALE**—30-60 Aultman-Taylor (Gasoline Kerosene Engine and Guide; Eight Bottom Drive Plow; 30-60 Avery Separator. Two Tanks; run two seasons. Terms to reliable parties. Paul Edwards, Shaunavon, Sask.

**WANTED**—Information regarding good farm or unimproved land for sale. R. G. List, Minneapolis, Minn.

**GASOLINE ENGINE** with plows, also 2 1/2 and 3 1/2 in. Advance Separators in good condition, discs, binder and other implements for sale. Easy terms. "Y," this paper.

**ONE 6-FURROW 14in. Cockshutt Engine** (gang, with stubble bottoms in good shape). J. C. Logan, Carnduff, Sask.

**FOR SALE, 20 H.P. portable international Gasoline Engine**, in good condition; only been run 60 days; cheap. Apply Richard Airey, Foreman P.O., Alberta.

**ENGINEER** having 6 year's experience with both gas and steam tractors wants position for the coming season; hold 100 h.p. Sask. steam certificate and gas engine certificate from the Man. Agricul. College. Do my own repairing. Can give best of references. Prefer 4 cyl. tractor (case or Rumely Oil Pull or any make of steam engine. Apply early, stating wages, make and size of engine, to E. K. Siemens, Arcola, Sask. Box 246.

**GASOLINE TRACTOR**. Five year's experience, first class references. Open for engagement. Give full particulars. Claude R. Green, Perth, N.B. Vic. Co.

**WANTED FOUR BOTTOM ENGINE GANG**. Must be in first class condition and equipped with breaker bottoms. Be sure and state price. Address H. F., 304 Lilac Street, Winnipeg.

**WILL EXCHANGE, 100 Acres Mixed Farming Land** for Separator, about 20 in. cylinder; must be complete and in good running order. Sykes, Russell, Man.

**FOR SALE**—1 30-60 Hart-Par Engine, 1 30-60 Sawyer-Massey Separator. Set of Emerson Engine Disc Plows, 14 Discs, 2 Sets Emerson Engine Disc Harrows, 1 Cuddy Steering Device, 1 Stewart Stook Loader. All in first class working order. Three thousand dollars cash takes the lot. A. Tuxford, Tuxford, Sask.

**FOR SALE**—"Big Felt" 30-60 Gas Tractor in good running condition. Address R. P.O. Box 3164.

**WANTED**—To hear from owner of good threshing machine for sale. Send description and price. R. G. List, Minneapolis, Minn.

**FOR SALE**—110 H. Case Steam Tractor, 40-62 Steel Separator, 10-Furrow Cockshutt Gang, Stubble and Breaker Bottoms; three 2 1/2 in. Derré Jumbo Breakers; bargain. Candy & Co., Edmonton, Alta.

**WANTED**—To hear from owner of farm or fruit ranch for sale. O. O. Mattson, Minneapolis, Minn.

**SAVE MONEY** BY SENDING YOUR  
BROKEN OR CRACKED CYLINDERS, CRANK CASES, GEAR WHEELS, GEAR HOUSINGS or MACHINE PARTS to  
**Hub Welding Company**  
253 Sherbrooke Street Winnipeg  
LOWEST PRICES CONSISTENT WITH BEST WORKMANSHIP

**WINNIPEG (MADE IN THE WEST) STEEL SHINGLES**  
GALVANIZED OR PAINTED  
Houses, Barns and other Farm Buildings need protection against Fire and Lightning. Metal Roofs are the most permanent and economical protection you can get.  
**WINNIPEG SHINGLES**  
Made in the West to suit Western conditions, have proved their worth in service, and are guaranteed equal to the best and better than most.  
WRITE FOR FREE INFORMATION AND PRICES  
**Winnipeg Ceiling and Roofing Company, Limited**  
P.O. Box 3006 C.T.I. WINNIPEG, Man.

**Strite Variable Speed Governor**  
Is the best by every test for running cream separators, washing machines, flax-mills, or any light machinery.  
More cream separators driven by Strite Governor Pulleys than all others combined. THERE'S A REASON—ASK US.  
**STRITE GOVERNOR PULLEY CO. 8. BRD ST., MINNEAPOLIS**

**Pace, Harrison, Limited**  
Winnipeg  
**INSURANCE**  
LIVE STOCK  
Fire  
Accident  
Sickness  
Automobile  
Plate Glass  
Liability  
Bonds  
Tornado  
**WRITE FOR AGENCY**  
**Pace, Harrison, Limited**  
General Agents, Winnipeg

**The "Challenge"**  
WATERPROOF all-linen COLLAR  
THE CHOICE OF PARTICULAR MEN  
SPRAY-SPYLLISH—ECONOMICAL  
NO LAUNDRY BILLS TO PAY  
AT YOUR DEALER'S, OR DIRECT, 25c  
100-100-100  
THE ABBINGTON CO. LTD.  
OF CANADA, LTD.  
TORONTO  
MADE IN CANADA

**Good For Man And Beast**  
Kendall's Spavin Cure has now been refined for human use. Its penetrating power quickly relieves swellings, sprains, bruises, and all forms of lameness. It is just what you need around the house. Write for many letters from users to prove its effectiveness.  
Beach of Kempstons have used your Spavin Cure for years and find it a wonderful liniment.

**Kendall's Spavin Cure**  
—has been used by horsemen, veterinarians and farmers for over 30 years. Its worth has been proved for spavin, splint, curb, ringbone and the many other hurts that come to horses. Read this letter from James P. Wilson, Kingsland, Sask.:  
"I have used your Spavin Cure time and again with good results for swelling of rheumatism, both in man and beast, and found it very satisfactory."  
Get Kendall's Spavin Cure at any drugstore. For horses, 4-oz. bottle, 60c. For humans, 3-oz. bottle, 60c. Refined formula 60c.—60c. 25c.  
"Treatment on the Horse free from druggists." Write to  
**Dr. B. J. KENDALL CO.**  
Emsburg Falls, W. U.S.A.

Ford R  
Ford T  
Ford Co  
Ford Se  
Ford Tc  
f. o

Governor

it by every...  
cream separa...  
g machines, la...  
or any light

nam separate...  
write Governor...  
an all other...  
THERE'S A...  
ASK US.

ST., MINNEAPOLIS

son,

E

ICV  
mited  
niipeg



Allied  
Beach of  
Kemptville,  
Ontario  
have used  
Kendall's  
vinyl floor  
coats and  
a wonder-  
ment."

's  
re

by home-  
use and  
35 years,  
a proved,  
ery, ring-  
ay other  
times.  
James P.  
K...  
vin Cure  
suits for  
who man  
nd found  
stators,  
ennial A  
Cure at  
nights &  
rks \$1.  
4 for \$1.  
formak  
e \$2.50.  
e on the  
re frak  
ur

DALL GA  
U.S.A.

# Canadian Ford Car Parts Reduced \$147 Per Car Since War Began

It is well known that the war has increased the price of practically all raw materials.

And, although all but \$16.88 worth of material that goes into the construction of the Ford car is bought right here in Canada, a high import duty adds its burden to that material that must be bought in the United States.

But in spite of increased duty and increased cost, the prices of parts that go to make up a complete Ford car have been decreased \$147 since war began.

This reduction was made for two reasons. First, because under normal conditions, increased quantity production would have made these lessened prices possible. Second, under abnormal conditions brought about by the war, the executives of this company felt it their duty as loyal British subjects to absorb these taxes of war into their manufacturing costs.

This reduction in price of parts is of first importance as a reduction in the cost of service to Ford owners. Prices of Ford spare parts have always been exceptionally low as compared to prices of parts for other cars, and under war time conditions the Ford company might have withheld, with seeming justice, any reduction in the price of parts in times such as these.

But the Ford Canadian executives had enough confidence in the progress of the Dominion and of the Empire to feel that the future prosperity of the country was sufficiently assured to warrant making these reductions.

This is improving a service already unrivalled in its efficiency. Ford, the Universal Car, can as well be named the Car of Universal Service.

Thus the Ford Company has left dollars in the pockets of Ford owners which it might have acquired were it not for its policy of the best service at the lowest cost. Even the finest piece of mechanism, often through abuse or neglect, sometimes requires attention. The remarkable economy of this Ford service is known to motorists all over the world.

In every community of any size in the Dominion there is a Ford dealer who carries a complete stock of parts and whose establishment is in itself a well equipped service station. A Ford owner, no matter where he drives his

car, is never far distant from a Ford service station that is ready to give prompt and efficient service in any emergency that may arise.

Moreover, Ford parts, as is the Ford car itself, are standardized and will fit in place in any Ford car to the thousandth part of an inch.

And every Ford dealer, because of this standardization of parts over a number of years, has an expert knowledge of the construction and repair of the Ford car. There is absolutely no guesswork in this Universal Service to Ford Owners.

Backing up the service afforded by over five hundred Ford dealers are the nine Ford branches located in the nine leading Canadian cities from St. John to Vancouver.

In four of these Canadian cities new branch buildings have been constructed since the war began and are themselves as large as many automobile factories. They are so completely equipped as to be able to build a Ford car complete. The buildings alone for these four new branches were erected at a cost of over a million dollars.

This immense expenditure is another indication of the attitude of absolute confidence in Canadian prosperity that has always been shown by the Canadian Ford executives and that has not been altered in the slightest degree by any war conditions.

At the same time that reductions in the price of Ford car parts were made there was also made a reduction in the price of the complete car. Twice—on August 1st, 1914 and August 1st, 1915, the price of the Ford car was reduced by \$60—a total reduction of \$120 in the price of the car since the start of the war.

This reduction is made on an estimated production of a definite number of cars for the coming year. Forty thousand Canadian Ford cars must be built and sold by August 1st, 1916 in order to warrant this last reduction of \$60 in price.

And here is another most emphatic expression of confidence in Canada. The Ford Canadian executives are basing everything on the continued and increasing prosperity of the Dominion.

And their judgment is being fully justified.

## Ford Motor Company of Canada, Limited, Ford, Ontario

Ford Runabout	-\$480
Ford Touring	530
Ford Coupelet	730
Ford Sedan	890
Ford Town Car	780

f. o. b. Ford, Ontario



All cars completely equipped, including electric headlights. Equipment does not include speedometer.

4-B

# CASE

## Steam Engines Famous the World Over

The high prices of gasoline has turned the attention of farmers and threshermen back to the good old line of Case Steam Engines. Right now there are thousands of Case engines in actual operation. Ask the man who owns a Case steam engine—that's the strongest proof—we'll warrant you'll find a contented customer. Case engines have "made good" on proofs not promises.

Some gas tractors are practical successes, Case gas tractors are numbered among these few. But in certain localities and for certain kinds of work we have maintained that steam is and always will be the most satisfactory power. Hence we have continued to refine and improve Case steam engines until today they are without equals—their records in almost every civilized country prove this fact.

### Features worthy of our attention

1. Simplicity: As illustrated by the fact that we build the single engine type only.
2. Stability: As shown by the fact that our boilers are built so well that they meet the law requirements of practically every country in the world. This means that anyone can use his Case steam engine anywhere.
3. Economy: Case steam engines have won in every contest for fuel and water in which they have been entered.
4. Accessibility: All working parts are in full view of the operator.
5. Power: Case steam engines develop more power per pound of weight than any other.

Case steam engines are built in sizes of 30 - 40 - 50 - 65 - 75 - 80 and 110 horsepower.

Limited space does not permit of explaining them all in detail. If you want all the facts, if you are interested in knowing how carefully Case engines are constructed, if you want to compare Case with other makes, send for our 1916 Catalog. It is brim full of the information you are seeking. A postcard brings it.

J. I. CASE T. M. CO., Inc. 765 Liberty St. Racine, Wisconsin

