

Technical and Bibliographic Notes / Notes techniques et bibliographiques

The Institute has attempted to obtain the best original copy available for filming. Features of this copy which may be bibliographically unique, which may alter any of the images in the reproduction, or which may significantly change the usual method of filming, are checked below.

L'Institut a microfilmé le meilleur exemplaire qu'il lui a été possible de se procurer. Les détails de cet exemplaire qui sont peut-être uniques du point de vue bibliographique, qui peuvent modifier une image reproduite, ou qui peuvent exiger une modification dans la méthode normale de filmage sont indiqués ci-dessous.

Coloured covers/
Couverture de couleur

Coloured pages/
Pages de couleur

Covers damaged/
Couverture endommagée

Pages damaged/
Pages endommagées

Covers restored and/or laminated/
Couverture restaurée et/ou pelliculée

Pages restored and/or laminated/
Pages restaurées et/ou pelliculées

Cover title missing/
Le titre de couverture manque

Pages discoloured, stained or foxed/
Pages décolorées, tachetées ou piquées

Coloured maps/
Cartes géographiques en couleur

Pages detached/
Pages détachées

Coloured ink (i.e. other than blue or black)/
Encre de couleur (i.e. autre que bleue ou noire)

Showthrough/
Transparence

Coloured plates and/or illustrations/
Planches et/ou illustrations en couleur

Quality of print varies/
Qualité inégale de l'impression

Bound with other material/
Relié avec d'autres documents

Continuous pagination/
Pagination continue

Tight binding may cause shadows or distortion along interior margin/
La reliure serrée peut causer de l'ombre ou de la distorsion le long de la marge intérieure

Includes index(es)/
Comprend un (des) index

Title on header taken from:/
Le titre de l'en-tête provient:

Blank leaves added during restoration may appear within the text. Whenever possible, these have been omitted from filming/
Il se peut que certaines pages blanches ajoutées lors d'une restauration apparaissent dans le texte, mais, lorsque cela était possible, ces pages n'ont pas été filmées.

Title page of issue/
Page de titre de la livraison

Caption of issue/
Titre de départ de la livraison

Masthead/
Générique (périodiques) de la livraison

Additional comments:/
Commentaires supplémentaires:

This item is filmed at the reduction ratio checked below/
Ce document est filmé au taux de réduction indiqué ci-dessous.

10X	12X	14X	16X	18X	20X	22X	24X	26X	28X	30X	32X
<input type="checkbox"/>	<input type="checkbox"/>	<input type="checkbox"/>	<input type="checkbox"/>	<input type="checkbox"/>	<input type="checkbox"/>	<input type="checkbox"/>	<input type="checkbox"/>	<input type="checkbox"/>	<input type="checkbox"/>	<input type="checkbox"/>	<input checked="" type="checkbox"/>

THE CANADA LUMBERMAN

VOLUME XVI.
NUMBER 8.

TORONTO, ONT., AUGUST, 1895

TERMS, \$1.00 PER YEAR
Single Copies, 10 Cents.

THE ORIGIN OF THE WORD "LUMBER."

THE word lumber, says the Timberman, which has an essentially American origin as applied to manufactures of timber, was first used in Boston in an official way in 1663. It is a most comprehensive word, and other countries have no expression for it that covers the ground so completely. In Great Britain, for instance, each item of lumber has its name, as with us; but, if they were speaking of manufactures of wood as a whole, about the only term which they have that covers the case is "wood-goods," which is an awkward expression at best. The word lumber was coined in Boston. A recent writer in the Boston Journal states that the word has not had full justice accorded to it. From 1630 for nearly one hundred years Boston was the chief lumber market of the world, and that industry was one of the principal foundations of Boston's wealth. Other Boston staples were fish and leather, but in magnitude of transactions lumber was in the lead. The site of the old state house, known as Market Place, was formerly a lumber yard. The men of Boston got to calling sawn timber lumber because the ships that brought that article of commerce to Boston used to lumber up the wharves and streets with their product. In 1663 the police regulations of Boston provided that the wharves and all streets "that butted upon the water" must be kept free from all "lumber and other goods." Boston lumber carried in Boston ships went to all parts of the world and laid the foundation for Boston wealth. It is said that the first cargo returned by the Pilgrim Fathers to England was a cargo of pipe staves, and for the reason that Europe could not produce as good an article, it was a profitable venture, netting the shippers five hundred pounds. In that industry the Puritans were satisfied that all Europe could not rival them. The term lumber included masts, staves, clapboards, shingles, boards, planks and timber. Although Boston is still a large lumber market and has continued so through all these years, it did not long maintain its supremacy in this country, being early overshadowed by New York and many other markets, and now all of these are inferior to the great city of the West, Chicago.

ANCIENT WOOD HOUSE IN JAPAN.

JAPAN possesses what is probably the oldest wooden structure in the world. It contains the art treasures of the Mikado and is situated in Nara, which for some years was the imperial residence. The building is oblong in shape and is built of triangular logs of wood. It rests on piles. The wood used is of native growth and shows extraordinary lasting power, considering the trying climate which it has had to endure for over 1,200 years. A peculiar feature about the logs of which the building is constructed is that, in the parts most exposed to the weather, the logs are thinner by several inches than in those in a more sheltered position, the wood having gradually worn away. The treasures which the storehouse contains are of great antiquity and have been seen by Europeans during only the last three years. They consist of rare and beautiful fabrics of Persian, Indian, Chinese and Turkish manufacture and ancient articles from all parts of the world. Among the objects of interest is the earliest known specimen of Japanese printing. Even to-day many of the words are easily decipherable. The treasures have remained undisturbed in the same building for 1,200 years, and despite the troublous times through which it has been in existence, it has never been injured or disturbed. Many of the treasures are still packed up in the storehouse chamber underground, where they have lain for hundreds of years, and when they are brought to view some new light may be thrown upon the early history of the country.

THE LATE SENATOR KENNEDY F. BURNS.

IN the death of Senator K. F. Burns, of Bathurst, N. B., a few weeks since, the lumber trade has lost one, who, for many years, had been prominent in its ranks.

Mr. Burns was a native of Ireland, having been born at Thomaston, County of Tipperary, Jan. 8th, 1842. He came to New Brunswick when a boy and his education was obtained in Halifax, N. S., and St. John, N. B. In 1857 he became a resident of Chatham and in 1861 settled in Bathurst. In 1878 he formed a business partnership with the Hon. Samuel Adams, and his brother Mr. P. J. Burns, the new firm going extensively into lumber, and erecting a fine saw mill at the mouth of the Nepisiguit river, opposite the town of Bathurst.

On the retirement of Mr. Adams the business was carried on under the name of K. F. Burns & Co., until May, 1890, when it became merged in the St. Lawrence Lumber Co., Ltd., with mills at Bersimis, Que., Bathurst and Caracquet, N.B., and offices in London and Liverpool, Eng. Considerable English capital was invested in the business, and apparently a profitable trade was done for some years. Within the present year, however, the



THE LATE SENATOR KENNEDY F. BURNS.

company became financially embarrassed and at the present time it is in course of liquidation, Mr. Burns having been one of the liquidators.

Mr. Burns was a public spirited man, having represented Gloucester in the House of Assembly for several years. In 1882 he became a member of the Dominion House, as representative for Gloucester. Later on he was appointed Senator by the Dominion Government.

Personally the deceased possessed in a generous measure the elements that give success and popularity in life, and in his death a blank is created in the business and social walks of the Maritime Provinces.

SHIPPING LUMBER.

IN loading lumber, especially timber, upon flat railroad cars, says the Tradesman, some provision must be made for holding the top end of the stakes firmly in position so that they may not bulge outward or break off owing to pressure of the lumber as it shifts about in going up or down grades or round curves. Some shippers nail pieces of board across from stake to stake. This method is not accepted by some railroads, as it is claimed that the nails may break off. Other shippers put sapling poles across and spike the poles to stakes. This method is open to the same objection as the first. Still another way is to put telegraph wire across from stake to stake; half a dozen strands of wire thus strung across forms a very stout and handy method of tying the sticks together, especially as a twister can be inserted in the middle of the car between the strands of wire,

and the stakes drawn into the required positions. The great trouble with this method is that the wire is rather expensive. Some enterprising shipper has been sending me timber with a combination of the wire and sapling methods. He puts in sapling stakes, places a sap pole across from stake to stake, notches the ends of both stake and pole and then wires them together with a few short pieces of No. 8 wire. Very little wire is used and the job is as strong as where the all-wire connection is made.

THE SEASON FOR CUTTING TIMBER.

THAT there is a right season for felling timber, and that the value of timber for building purposes largely depends on this season being chosen, are generally admitted facts; yet the practice of different people and districts, says the Carpenter and Builder, is found to vary most essentially. Thus, while the time for cutting timber for building is largely fixed in Germany in the months of November, December and January; in the Alpine districts of Switzerland and Austria the best and most durable timber for building is considered to be that which is felled in the summer. The reason of this is that the wood of coniferous trees—fir, pine, etc.—contains least moisture in May and June, and as the felled timber is left on the ground till the following winter, it becomes well dried before it is taken away. However this may be with the coniferous trees of the mountainous districts, it is certain that the trees in the plains require different treatment. The question has been subjected to a series of tests in Germany, and the result is sufficiently conclusive. In one case the experiment was with four beams of equal length, breadth and thickness, sawn and shaped in the same fashion, cut from trees of the same kind growing close to one another, and kept on the same dry spot, the only difference between them being that they were cut in four different months. The timber felled in December was the strongest of all; that cut in January was 12 per cent. inferior to it in point of strength or of power of bearing pressure; that cut in February was 20 per cent., and that cut in March 38 per cent. weaker than the December timber. In another experiment entire pine trees were buried in a moist damp soil; one sort had been felled in December, the other in February. It was found that the latter had turned rotten in eight years, while the former was sixteen years before it decayed. A similar experience with deal planks showed that those sawn from trees felled in March decayed in two years, while planks from December timber last six years.

SAWING PATTERN LUMBER.

BETTER patterns, says a writer in an exchange, can be made if the lumber be sawed with a rift or quartered saw, as frequently termed. It may be something new for the pattern maker to use "quartered pine," but the patterns he makes of that lumber will stay in place much better than when sawed off the log in the usual manner. An old pattern maker of my acquaintance, whenever he is called upon to make a particularly nice pattern, always splits out his pattern stock with an axe, taking a log of sufficient length to make the desired pieces. He splits this log carefully in the middle, then splits each half into quarters, and bews out from these quarters the required shapes to make his patterns. Quarter sawing comes very near to the effects secured by the hand axe pattern maker alluded to above. The foundry worker has long been aware that quartered oak stays in place much better than cant sawed oak, which means sawing off one side of a log, then beginning over and sawing the other side.

Moffatt & Co., of Renfrew, Ont., are building a large addition to their wood-working establishment.

BY THE WAY.

THE British Columbia Board of Trade has made the suggestion that a system of grading to standard specifications should be followed by the lumbermen of that province. This much has been learned by lumbermen in different sections of the Dominion, and elsewhere, that trade is very much facilitated the nearer its members can get to a good system of grading and inspection. In fact, it is a difficult matter to do business with foreign countries, or distant parts of one's own country, if some system of inspection has not been adopted; and some of the difficulties that lumbermen in Ontario have to encounter is through want, especially in pine, of a uniform system of grading. With export trade on the Pacific Coast growing into large figures, and wide in its extent, the suggestion of the Board of Trade would strike us as practicable and desirable. As indicating the volume of lumber trade in British Columbia the following estimate may be quoted: 524,573 acres leased to millowners are estimated to contain at least 20,000 feet of timber per acre. During 1894 13,730,764 feet were taken from these leased lands, which, together with the timber taken from crown lands, timber limits and private property, make the total of timber cut during that year 67,499,277 feet. The exports during the same period were 46,290,000 feet, or about two-thirds of the whole.

x x x x

WHERE there is no force in the objection made against paper manufactured from wood-pulp when used simply for newspaper and current magazine publishing, because it possesses no durable qualities, there is much force in the charge when book publishing is considered. The newspaper or magazine is of to-day. Within the covers of the best books on our library shelves are supposed to be preserved the thoughts of the ages, and if it is to be shown that books made from wood-pulp paper would in a few years crumble to pieces and pass out of existence, it means a blotting-out of the literature of the ages. Tests have been made to prove the falsity of these objections. The first book made of ground wood paper has recently been placed in the Berlin testing office for examination. It is said to be in good condition. As it was printed in 1852, very nearly half a century ago, the argument that wood paper has no durable qualities appears to be seriously shaken. With the wood-pulp business growing apace lumbermen have a vital interest in the lasting success of the business. The fact here stated is one in favor of wood-pulp and wood pulp lumber. En passant, it may be remarked that British Columbia is asserting its position as a district suited for the building of wood-pulp mills, the spruce of that country, it is claimed, being an excellent wood for this purpose.

THE ONLY TEST OF MERIT.

THAT the people are quick to appreciate a good thing when they see it is abundantly shown by the phenomenal record of the Toronto Industrial Exhibition. The Fair which begins on the 2nd of September next is the seventeenth of the series. It has grown steadily in popularity and yearly attracts increasing numbers, which is the best possible proof of its superior excellence. This season the display will be more complete and varied than ever. The number of entries is unusually large in all departments. Already every foot of space in the building is taken up through additions, and re-arrangements have been made to accommodate the increased number of exhibitors. Great improvements have been made in the accommodations provided and all arrangements for public convenience are as nearly perfect as possible. An attractive and diversified programme of entertainments is offered. All railways will give low rates and special excursions will be run from many points, presenting an opportunity of which all should avail themselves.

PUBLICATIONS.

IN its particular line it would be hard to find a journal that so completely meets the bill as The Ladies' Home Journal, of Philadelphia. The editor, Mr. Edward W. Bok, has obtained much fame for the success that has reached his journal, the circulation now climbing up to something like a million. Mr. Bok is possessed of that important faculty in an editor of judging what is best liked by his readers, and knowing where to lay his hands on such matter. The current issue of The Ladies' Home Journal is one of the best that has been issued.

PRINCIPLES OF MANAGEMENT.

BUSINESS principles are like other principles—rules with exceptions. If a business man is able to manage his affairs in a way that does not show evident inconsistency in acts or views, he must be considered a man of principles, even if the rules he tries to enforce in his life have many exceptions.

Without principles, no system; without system, poor management. This is a truth inside and outside a saw-mill plant. One of the principles that seem to be of the greatest importance in the management of a concern where many different men are employed, is what might be called the tracing principle, the method by which the manager at any time, and on any occasion, is enabled to find the responsible author of an act, whether the act be of advantage or disadvantage to his business.

If a car-load of lumber is not properly loaded, the inspector is responsible; if a stack of lumber is destroyed by careless stacking, the yard foreman is responsible; if ten per cent. of the daily output from a saw-mill is miss-cuts, the saw-mill foreman is responsible. But the tracing system does not stop here; it will investigate the matter farther, if the system is more than superficial. The inspector will know who placed the lumber in the car, the yard foreman who stacked the pile and the saw-mill foreman who made the miss-cuts. Of course this circumstance does not relieve the bosses from their responsibility, but it gives them the means to prevent such damage in the future, if they keep their eyes open; and just because they had the opportunity to apply the tracing principle themselves, they are inexcusable for the loss their carelessness has caused their employer.

Especially in a saw-mill, the irresponsible machinery is too often blamed for mishaps that ought to be traced back to some responsible person. If a box runs hot, and the mill has to stop for 15 minutes, causing 20 or more men to stand idle, nobody is blamed but the box; if a saw runs off and bursts all to pieces, nobody is blamed but the saw or the wheel; if a belt breaks, it was only the belt that broke. But when the manager knows that the conditions of the box, the well and the belt only represent the work and degree of care of some responsible individual, he will soon find the cause and this individual, and by holding him responsible in every instance, he can prevent the bad luck a hundred times easier than he can fix up the broken material. The material is all right, it is always the man who is wrong.

Let us try the principle on the yard. The inspector is shipping a car-load of saps; he finds the greater part of them black and mouldy, partly because they have been stacked with rotten strips, while the sap side has been turned upwards, and the boards have been laid too close together; partly because the air course is too narrow and the foundation too low on the damp ground, or through a poor roof of mill culls the rain has been pouring down upon the upper courses, leaving them wet for months. It takes the inspector all day to load his car, as two-thirds of the saps have lost in value, even to the limit of shipping culls, and there is consequently hardly any profit on the lumber. The manager commences his investigation: he goes to the yard foreman, who is responsible for the good condition of his stock, and he, who has, or at least ought to have, his yard divided up among his stackers, immediately knows who built the stack, and by gross carelessness caused a loss to the concern. The cause of the evil will be removed, and the cut thereafter will show some bright saps.

And now let us look inside the saw-mill. A large percentage of the daily output shows up as miss-cuts. What causes them, or rather who makes them? The sawyers blame the filers, and they duly return the compliment; the case is laid before the foreman, who suggests some fault in the machinery, and finally acquits the culprits by giving mysterious hints in regard to the carriage track or set blocks; of course nobody is to blame but the machinery. The manager applies his tracing principle; a careful examination proves that the machinery is not at fault, and to find out who is, he gives the off-bearer at the one saw a piece of crayon and orders him to mark every board coming from this saw; at the same time the roll grader is ordered to lay out all the miss-cuts in separate piles of marked and unmarked boards. By quitting-time it is easily seen which saw

made the miss-cuts. As the sawyer is still blaming the filer, he is himself transferred to the other saw, and if his saw still keeps on making miss-cuts to an unreasonable extent, he is to blame; if not, probably the filer on his side is to be blamed, which can be found by transferring him and watching the result. In this way the tracing principle is applied, until the cause of making miss-cuts is found out, and probably removed by somebody's resignation.

If the examination of the machinery has brought out the result that it was really out of order by not being in line, or similar serious causes, the foreman may be to blame himself, either for his ignorance of the fact or for not using his knowledge to his employer's advantage--if he really had a chance.

The tracing principle is not only a handy method, but it is absolutely necessary in the management of a saw-mill plant, and if there ever was a rule without exceptions, at least practically, it ought to be this: The machinery is all right, it is always some individual who is wrong.—O. C. Molbeck in *Hardwood*.

A NEW ABRASIVE.

SOMETHING new is offered to metal-workers and others in the shape of an abrasive called "krushite." This consists of minute chilled cast metal shot, varying in size from powder to clover-seed size, which is chilled to intense hardness without becoming brittle, a fact proved by striking it on an anvil, when the latter will be indented. It is claimed to be superior to sand, emery or corundum for stone-cutting, polishing and similar work, the action between the blocks and saw-blade or "rubber" being a crushing one, and the balls do not lose their spherical shape. The wear and tear on the rubber is considerably lessened, and the power required is reduced one-half. Krushite is especially adapted for sawing blocks of granite, for the sand-blast and a substitute for diamond drills in boring. One ton of krushite is said to be equal to three tons of the sharpest sand.

PERSONAL.

The Hon. J. K. Ward, the well known lumberman of Montreal, is at present with his family on a visit to Europe.

Mr. William Margach, Crown Timber Agent for the Rainy River district, is at present on a short visit to Scotland.

Mr. John I. Davidson, of the firm of Davidson & Hay, the well-known lumbermen and wholesale grocers, is likely to receive the appointment of Senator.

Miss Clara C. Tait daughter of Mr. Andrew Tait, lumber merchant of Orillia, Ont., was recently married to Mr. W. Carrs, of the firm of W. Carrs & Co.

The death is announced at London, Ont., of Mr. William Willis, who for upwards of fifty years has been engaged in the lumber business in that city. He was 78 years of age, his father being one of the pioneers of this country.

TRADE NOTES.

The E. R. Burns Saw Co. have issued an illustrated catalogue and price list of their special silver steel and cast steel saws, and other goods manufactured by them. The book also contains many useful hints for saw mill men.

The attention of lumbermen is called to the advertisement of H. P. Eckardt & Co. This firm is making a specialty of furnishing supplies for camps and is in a very favorable position to enable them to do this class of business right.

The machinery business carried on for many years at Toronto and Montreal by Mr. A. R. Williams has been transferred to the A. R. Williams Machinery Supply Co., with which has been incorporated the Machinery Supply Co., of Brantford.

The Magnolia Metal Co. of New York and Chicago advise us that their business during the month of May has been the largest during the past two years, and that they have abundant evidence of a general revival in business. As their business is largely with mills and manufacturers in all parts of the country, this is one of the best indications of the improvement which has been so long looked for.

Attention is directed to the advertisement appearing in this number of Mr. Thos. Pink, of Pembroke. Mr. Pink is the manufacturer of a patent saw mill carriage cant hook, with which he has supplied some of the most prominent lumbering firms throughout the Dominion from the Atlantic to the Pacific. Mr. Pink has been in business at Pembroke for 30 years past, during which time he has built up extensive business in his particular line of manufacture.

THE BAND SAW.

A BAND saw will saw probably four times as fast as a jig saw, and it works quite as smoothly, requiring no blower to keep the sawdust away. The jig saw has the great point in its favor that it is able to do inside work, so if possible have both a jig and a band saw, but if only one can be used take the band saw every time.

On pattern work, to saw a place having no connection with the outside, simply saw boldly in on a straight line until the inner design is reached, then saw around it, and draw the work away from the saw by means of the cut first made. Now glue in a thin piece of wood the width of the saw kerf, and when the pattern is finished it will not show if black shellac is used.

It is possible, (although not always convenient,) to do anything by means of a band saw that is commonly done on a circular saw, except rabbeting and dadoing pieces that are over a foot or 15 inches in length, so if it were not possible to have more than one saw for ordinary machine pattern work, the band saw would be the last to be parted with, because it covers the widest range of usefulness.

I am the champion of the band saw, for it is a noble tool when properly treated, but if not the results are poor enough, for no machine tool will realize its capabilities without proper attention. A band saw should be kept sharp, with enough set to prevent its binding on a curve, and no straggling, ragged teeth, which are worse than dull ones. It is also necessary to have the saw properly secured between guides to insure precision.

The breakages are caused oftener than any other way by crowding stock against a dull saw, or by suddenly wrenching it sidewise. Very frequently a saw about to break will give a warning thump every time the weak tooth passes through the work. When this sound becomes too pronounced, it is better to stop the machine and remove the saw, breaking it by hand before using. A saw that thumps generally has the weak spot where the joint was brazed. No one can predict, as a general thing, when a break will occur; the unexpected often happens, and sometimes when the machine is started up the blade will snap before the workman even touches it with the stock, and also sometimes when the shipper rod is shifted to stop the saw, the blade will break before the workman reaches his bench. This is apt to happen when a saw has been used for a long time.

An even tension of the blade is an important point. Some saws are provided with an index to register this, while others are not, and the workman turns the hand wheel which tightens the blade by guess, and the saw is at the mercy of the man's muscle, probably never being strained to exactly the same tension to successive times. Anyone not acquainted with band saws when entering the pattern room and looking at one, is almost sure to ask, "Do they ever break?" and when being answered in the affirmative, the next thing is, "Do they hurt anybody?" the idea in their minds seeming to be that they would wind around one like a python in case of a breakage. This idea is erroneous. There is not one chance in one hundred of being hurt, but it is a decidedly startling sensation the instant the snap comes, and it makes one jump.

I have seen many saws break, but was never even scratched save once, and then only slightly, on the fingers. When the snap comes, it instantly releases all tension and also any onward motion of the saw, the ends simply throwing themselves outwards and seldom scratching one. If the wheels are not rightly adjusted the blade will not keep its proper position as it revolves, and I have known a saw to fly off the rim a number of times when in motion without breaking. Once one came off in this manner and encircled the workmen as it dropped. This is a rare instance, and the man was, above all things, little expecting to be lassoed by a band saw.

The knack of folding saw blades is hard to catch, even when watching one do it, if it is done quickly. If done slowly, and one watches carefully enough to remember each motion, it can be acquired quite easily. Whether a person who has never witnessed it can accomplish it from any description of mind, is a question I will not try to answer.

Grasp the saw in both hands at about arm's length, standing where there is plenty of room, and having the

blade resting on the floor about a foot and a half from the feet. Now take one step backwards, at the same time bringing the arms together until the hands are about a foot apart. The saw is now divided into four curves, which we will call A, B, C, and D. Curve A points downwards, in front of the body, and C also in the same direction, resting on the floor. B points upward, and is governed by the right hand, and D exactly the same, only governed by the left hand. Now try to do three things at once; bring the hands together, so that curve B will cross curve D above it, and curve D take the same relative position in the opposite direction beneath it, while curve A is folded under them both. Now drop the whole affair directly over curve C, which rests upon the floor, and the saw is folded into three circles, ready to hang up. This is the common number of folds used, and they should not be increased unless for the purpose of getting the saw into a small compass for shipping purposes.

A saw can be brought into a very small compass, namely, nine circles, by taking it folded as just described, and considering it now as an entire saw, next folding it again, following the same movements on a reduced scale. This is quite difficult to do.

A better way to increase the folds above three circles is to hold the folded saw in the left hand, and with the right pull the blade out into one large loop, still retaining the folds in the left hand, and proceed as at first, only, of course, it is on a reduced scale, and throw the circles in the left hand in together with the others at the instant the saw is dropped.

A person can fold a blade just as small as he wishes by following these same movements over again for a few times.

The ends of the saw for brazing must lie upon each other, similar to the lap in an endless belt, and should each be filed back for the distance of two teeth, and then the saw placed in the brazing clamps. Do not have any two adjacent *half* teeth, as we might express it, come together pointing in different directions as to the set, but before filing the joint, take one end of the saw in each hand and place them by each other the length of two teeth, and notice if the bend in each tooth in the joint comes properly. If not, break or cut off one tooth from one of the ends, and then the trouble will be remedied.

Brazing clamps are furnished with band saws, and simply serve to hold the saw in position while being fastened. After giving the final turn with the thumb screws, be sure that the under edge of the saw is exactly in line where the joint come, and then proceed with the brazing. This can be done by using thin sheet brass, silver solder, or coin silver, and probably with other substances also, and acid or bora can be used in connection with them, together with hot blacksmith's tongs or a brazing lamp. For material I would advise silver solder and powdered borax, or if silver solder is not convenient to procure take a 10-cent piece and pound it out flat on an anvil flint it is quite thin, say, $1\frac{1}{4}$ inches in diameter or more. Now take a piece of the silver about the size of the lap, and moisten it, together with the halves of the joint; cover the solder with powdered borax, and the joint also, both inside and out, and place the solder carefully between the overlapping ends of the saw. The moisture makes the borax stick nicely. Next apply heat.

If tongs are used, they should have thick ends or jaws and should be brought to rather more than a red heat, that is, bordering on a white, and the joint should be nipped by them for a moment, until the solder flows freely, and then be carefully removed so as not to open the laps. Next sprinkle water over the brazed part, so that the joint will not be too soft. A little practice in this is needful, for if too much water is dashed on when the joint is still red hot it will make it so hard that there will be trouble in filing, but if this should happen it is very easy to hold the saw over a flame and draw the temper.

A good brazing lamp is much neater to use than tongs, and will save a journey to the blacksmith's forge to do the neatening, and also the carrying of saw and clamp as well. In whatever manner the saw is brazed, the heat ought to be concentrated just as much as possible on the

joint, so as to prevent its spreading, for heating the saw will not do it any good. If a joint is nicely made the saw should break in any other place just as readily when the time comes.

After the soldering or brazing just described, the joint must be filed and the excess of solder removed, and be sure that the blade at this point is no thicker than at any other. I consider a band saw about as easy a saw as I know of to file, and at the same time about as tedious. The teeth should be filed straight across, both on back and front, and the front should be slightly angling or hooking, so that the saw can take hold of the work to the best advantage. Machine filers and setters are coming to the front, and a really good one is an actual necessity, in a shop employing many men, simply in the time saved, but for the benefit of those who prefer to do it in the old way, I can say that I doubt if the actual results are much better than by careful hand work.—John M. Richardson, in American Machinist.

VINES DO NOT ALWAYS KILL TREES.

POPULARLY and erroneously it is believed that vines always kill the trees to which they attach themselves, but investigation shows that the belief is not confirmed by facts. The only cases of injury to the trunks of trees are when woody vines twine around the trunks. When vines travel perpendicularly in the same direction with the trunk, they may be a benefit rather than an injury. Nature has to make special provision in each tree for getting rid of useless bark, and the roots of vines like English ivy all help nature to get rid of this useless dead bark, and the shade which the leaves of the English ivy afford is a direct benefit to the living bark. These remarks apply to all vines that grow perpendicularly up tree trunks. When these vines reach the tops of the trees and spread over the branchlets, shading and in any way interfering with the healthy development of the tree foliage, then they are injurious. The English ivy seldom does this, but the American ivy, the Virginia creeper, or *Ampelopsis Virginica*, will often grow so vigorous as entirely to crowd out the leaves of the tree on which it grows. The grape vine will also do this, and so will many other climbers. It is only when they reach this mature state that vines injure trees.

AUSTRALIA AND CANADA.

WILL THEY EXCHANGE THEIR TIMBERS?

M R. J. E. ROUNDING, of Sydney, New South Wales, in a letter on the possibilities of commercial development between Canada and Australia, has this to say:—"In timber, as in most other products of the soil, nature has given Australia an article exactly the antipodes of the Canadian product. As the latter has vast forests of the finest soft woods, so has Australia immense supplies of hardwood unequalled in the world. By a mutual reciprocal arrangement the one could be exchanged for the other and mutual benefit ensue. Our hardwood has been proved to be the best known for paving purposes, and should be the means of solving a very vexed problem of Canadian municipalities, viz., that of the best paving material. Already the City Council of Vancouver has decided, upon my recommendation and offer, to lay down Australian hardwood blocks on the street leading to and from the Canadian Pacific railway station and wharves, probably the place where there is the most traffic in that city. For veneering purposes and furniture making our hardwoods are unequalled."

GROWING PINES.

M ANY students of trees assert that, when an oak forest is cut down, pines spring up, and that oak follows pine, and so forth, but this never really occurs except where the two kinds are not far from each other. In localities where but one kind exists, that kind succeeds itself. An intelligent Nevada observer notes that, where the pine timber was cut away 20 years or so ago, fine young pine trees, apparently about fifteen years old, now cover the same area. They grow so slowly when young, she says, that few observe them, but after a few years they grow rapidly. It is about the sixth or seventh year before they start on the rapid growth.

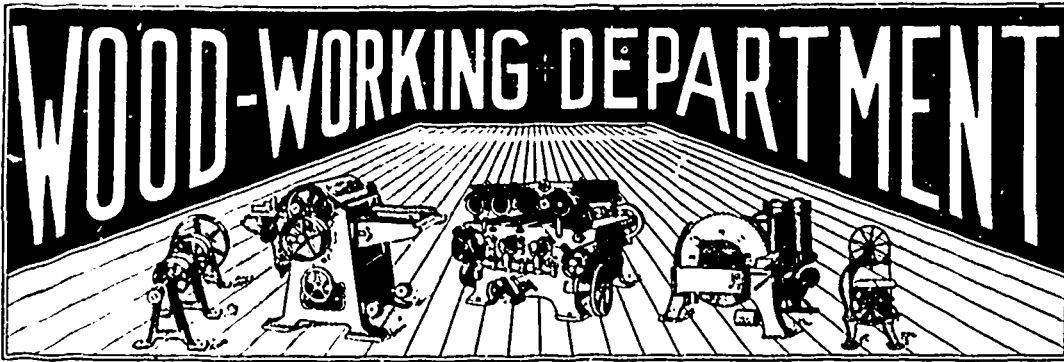

TRADE IN WOOD-WORKING LINES.

A STUDY of the figures contained in the report of the Department of Trade and Commerce, for the fiscal year ended June 30th, 1894, now published, furnishes some suggestive thoughts as to the possibilities of extending Canadian trade in wood-working lines.

The export trade in doors, sashes and blinds during the past five years has grown at a satisfactory rate, the business for 1894 being more than double that of 1890. The figures are as follows. 1894, \$158,196; 1893, \$130,349; 1892, \$123,144; 1891, \$86,450; 1890, \$60,474. Let this increase continue in the same proportion for another five years, or why not at a greater ratio, and the trade will have assumed a very considerable size.

The difficult matter in building up an export trade is to obtain entry into foreign markets, but having done this then time will establish the merits of the goods imported. Furthermore, it takes some years for manufacturers to ascertain just what class of goods particular localities require, and this now done, the business in doors, sashes and blinds of Canadian manufacture ought to grow apace. It is unnecessary to remark that no goods in these lines are imported into Canada, showing that the home goods are of a class that meet fully the requirements of our people, even those who may be deemed specially fastidious in their tastes, or who consider it the proper thing to look abroad for what is wanted.

If reference is made to the trade in mouldings it will be learned that the exports in this direction have since 1891 grown largely. The figures are. 1894, \$36,558; 1893, \$23,164; 1892, \$7,083; 1891, \$5,153. There was imported during 1891, mouldings to the value of \$31,745. The question may be asked. Why the necessity for imports, reaching almost the size of exports?

Figures bearing upon the manufacture of furniture are not so favorable. In 1894 Canadian furniture was exported to the extent of \$144,702, whilst there were imported goods to the value of \$276,909, on which a duty of \$93,104.11 was paid. It is a complaint among furniture dealers that for the finer classes of stock they are compelled to look to the United States. There hardly seems to be any reason for this. The raw material is here in abundance, and as a matter of fact Canadian lumber is shipped to the United States and comes back to us in the shape of furniture. Factories can easily equip themselves with the best in machinery, and there is a wide enough field for goods so generally in demand as furniture to encourage the manufacture of the finest class of stock.

NEW UNITED STATES PATENTS.

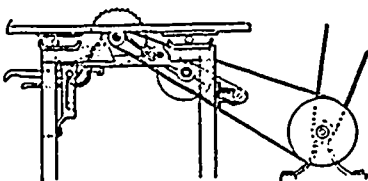

CIRCULAR SAWING MACHINE.

Patentee: Henry L. Beach, Montrose, Pa.; Filed Jan. 30, 1895; serial No. 536,687; dated April 16, 1895.

Claim.—1. In circular sawing machines, the combination, with a revoluble frame having arbors adapted to receive saws, of a support for said revoluble frame, adjustable in vertical planes, and a driving belt passing over revoluble frame to a pulley on one of the arbors, and receiving the revoluble frame centrally between its folds, said belt having its tension automatically adjusted

with relation to the kind of work to be performed, by the adjustment in vertical planes of the support for the revoluble frame. 2. The combination, with a frame revoluble about a certain axis, and carrying at each end an arbor adapted to receive a saw, of a frame pivotally secured and having the revoluble frame mounted within it whereby the cutting plane of the saws carried by the revoluble frame is adjustable in vertical planes by the movement of the supporting frame, a driving belt receiving the revoluble frame between its folds, and adapted to drive a pulley on one of the arbors of said frame, and means for locking the revoluble frame and pivoted frame in their adjusted positions. 3. The combination, with a revoluble frame carrying arbors adapted to receive saws, of a frame pivoted at one end and having its opposite end free, said frame supporting the revoluble frame and its adjuncts; a spring arm carried by the pivoted frame, having a means for engaging and locking the revoluble frame in position, means for locking the pivoted frame and means for operating the saws.

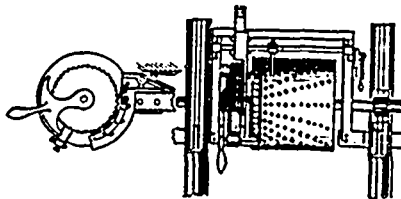

AUTOMATIC RECRDING SAW-MILL SET-WORKS.

Patentee: Algernon S. Pettigrew, St. Louis, Mo., filed Aug. 6, 1894; serial No. 519,522; patented in Canada Sept. 1, 1894, No. 46,918; dated April 23, 1895.

Claim. In a device of the class described, the combination of a segmental lever, a series of pawls each mounted on said lever on the same pin or bolt, another series of pawls mounted all on another pin or bolt and carried by the same lever, a separate series of pawls mounted on a stationary pin or bolt, a suitable reversing spring, a segmental pawl trip provided with an outwardly projecting flange and handle, said outwardly projecting flange adapted to engage upon the rear ends of the stationary and moving pawls, thereby disengaging the points of the pawls from the ratchet-wheel and allowing the wheel to reverse its motion.



ATTACHABLE SAW-TOOTH.

Patentee: James E. Emerson, Beaver Falls, Pa., assignor of one-half to E. C. Atkins & Company, Indianapolis, Ind.; filed Sept. 17, 1894; serial No. 523,275. Dated May 28, 1895.

Claim.—1. An attachable saw-tooth whose entire thickness is in excess of the thickness of the body of a saw and provided with a groove in the back of the tooth and with flanges fitting the sides of a permanent tooth of a saw. 2. An attachable saw-tooth whose entire thickness is in excess of the thickness of the body of the saw and provided with flanges fitting the sides of a plain permanent tooth, in combination with suitable means for securing the tooth to a saw. 3. An attachable saw-tooth whose entire thickness is in excess of the thickness of the body of a saw and provided with a groove in its back equal in width to the thickness of the saw and

with flanges fitting the sides of a plain permanent tooth of a saw, in combination with an attachable throat-piece whose entire thickness is in excess of the thickness of the saw and provided with flanges to engage the sides of the saw.

NEW ENGLISH PATENTS.

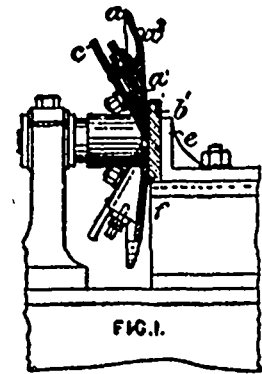

RELATING TO ROTARY CUTTER.

The following patent has been granted to J. Wheel- don, Stockport, Cheshire. It relates to a rotary cutter for wood-planing machines, consisting of a disc *a*, Fig. 1, on which two or more plane irons *c* are mounted with their cutting edges projecting sufficiently from the face of the disc. In the case illustrated, the face of the disc has two bevels *a'* and *a''* with different inclinations. The rough cut is made by the iron on the bevel *a'*, and the finishing or smoothing cut by the iron on the bevel *a''*, which extends to near the centre of the disc. To secure uniform thickness, the wood *b* is fed between the disc and an adjustable guide *e* bolted to the table *f*. In a modification, separate narrow irons are fixed on the bevel *a'*. The rotary cutter may be driven by a lathe or in the usual manner, by manual or motive power.

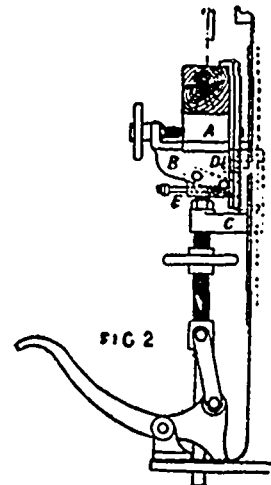

MORTISING MACHINE.

Patentee: Nicholas, D., Laurel Villa, Stroud Road, Gloucester.

Relates to an attachment to enable the table of a mortising machine to be canted to any required angle. The table *a*, Fig. 2, on which the wood is carried, is mounted on a bracket *B*, on which it can slide for horizontal adjustment. The bracket *B* is pivoted at *D* to the side *C*, and the bracket with the table can be tilted at different angles and held in position by a spring peg *E* which is inserted into one of the several holes in the framework. The slide *C* can be raised or lowered by a pedal connected as shown.

DRIVING BELTS.

BELTS for driving woodworking machinery should by preference be made of leather, except when used out of doors, or where likely to be wetted, when the use of vulcanized india rubber or india rubber cloth is advantageous. Belts are sometimes made of cotton, and we have recently seen one made of paper, which after twelve months' wear appeared in capital order. It was of American manufacture. Leather, from its strength, pliability, and durability, is especially to be recommended for narrow belts, or those running at short centres and high velocities. In calculating the transmission of

speed allowance must be made for "slip." The strength of the best ox-hide belts used for belting has been calculated at about 3.086 lbs. per square inch of section. This is reduced at a riveted joint to 1.747 lb., and to .960 lb. at a laced joint. One third of these figures may be given as a safe working tension.

As driving belts necessarily vary considerably, the following table, in pounds per inch width of safe working tension, may be of use:—

Thickness of Belt.	Working Tension.	Thickness of Belt.	Working Tension.
in.	lb.	in.	lb.
3/16	60	1/2	160
7/32	70	9/16	180
1/4	80	5/8	200
5/16	100	11/16	220
3/8	120	3/4	240
7/16	140		

For driving woodworking machinery belts should be used about one-third wider than is found necessary in machines running at a slow speed; they should be of uniform thickness, and kept as pliable as possible. After repeated experiments, we can recommend that driving belts should be run with their outside or smooth surface to the pulley, which is directly contrary to the practice now usually pursued, it being the custom to run the rough or flesh side of the belt on the pulley. It will be found that if a belt is evenly made, and smooth on its face, it bears equally over the whole face of the pulley, and not at certain points, as in the rough surface of the flesh side of the leather. With the smooth surfaces of the belt and pulley coming together the air is almost entirely excluded, and the "grip" or driving power of the belt is thus considerably increased.

Twisted belts should be avoided as much as possible; but if it is found necessary to connect by belt shafts that are not parallel, care must be taken that the belt is always in the plane of rotation of the pulley to which it is approaching, without regard to the retiring side, which may be deviated from that plane without affecting the belt. If this rule is borne in mind, little trouble by belts running off the pulleys will be experienced. When belts are required of greater width than 9 in., a double belt is preferable to a single one, and will run truer. As regards joining belts, many still pursue the old plan of lacing; we have found the double T belt fasteners expeditious and economical, especially for narrow belts, where the tensile strength is not great.

Very considerable trouble is often experienced in saw-mills in keeping the bearings and loose pulleys of the higher speeded machines in order, the friction and strain being in some cases excessive. They should, in the first place, be made of certain proportions; but no hard-and-fast rule can be laid down, owing to the varying and special conditions under which they are employed, and practical experience can be the only guide. Very great care should be taken in fitting them accurately to their various spindles, and when the strains are very great, they should be made of phosphor bronze.

Should the bearings "fire" or "seize," they should be removed and the faces let closer together, the whole of the abrasions being removed by a scraper; the bearings should then be accurately re-bedded on the spindle by means of red lead. The spindles should run easily without being loose, and should run at a dead level. All bearings should be guarded from dust as much as possible, and efficient means secured for their lubrication. Where the bearings are large and the pressure on them considerable, sulphur, black lead, or plumbago, reduced to a fine powder, and mixed with oil or tallow, retains the lubricating qualities of the unguent, and reduces the friction considerably. Soapstone is also highly spoken of as a lubricant for high-speeded spindles when reduced to a fine powder, and all gritty particles removed, and the powder mixed with unguents.

"Footstep" bearings, or those on which the lower ends of a vertical spindle rests, should have both lateral and vertical adjustments, and a recess for oil having direct communication with the bearing surface should be formed in the pedestal in which the bearing is fitted. Should a bearing "seize," pour cold water on it till thoroughly cool. If conical bearings are used care must be taken that the spindles are allowed no end play.

With machines having a reciprocating motion, such as saw frames, steam mortising machines, etc., it is of the utmost importance that firm and substantial foundations are provided, or, owing to the excess of vibration, the quality of the work turned out will be damaged. With machines working on the rotary principle, little difficulty is experienced, as most of the vibration is absorbed by the framing, assuming it to be well proportioned and the working parts truly balanced and fitted. To reduce the depth and lessen the cost of foundations, saw or swing frames should be connected to the crank shaft by two rods, one on either side of the frame. The reciprocating parts should be counter-balanced, and the crank shaft arranged as near the base of the machine as possible. The vibration is also considerably lessened by the introduction of a sheet of lead or a thin piece of hard wood between the base of the machine and crank shaft plummer blocks and the masonry.—Carpenter and Builder.

PATENT HORIZONTAL SAWING MACHINE.

WE give herewith a rough sketch, taken from a model, and a few particulars concerning a Patent Horizontal Sawing Machine of English manufacture. The objects the inventors have in view are the reduction of space required for the machine, and a higher speed than can at present be attained by the ordinary horizontal.

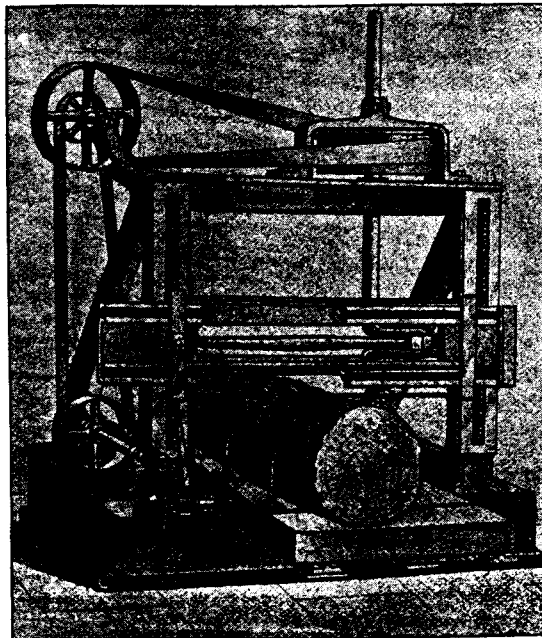

PATENT HORIZONTAL SAWING MACHINE.

They state that the crank, being vertical, requires no balancing, and therefore vibration is reduced to a minimum. The slide of the machine is on an improved principle, the frame for carrying the saws being driven by a bell crank working vertically between the standards and the slide. The crank shaft is driven from a counter-shaft, which is fixed to the machine. The same shaft works the feed, and thus makes the machine self-contained. The pulley on the crank shaft has an extra long boss, which works in a pedestal fixed to the top of the machine, the crank shaft sliding up and down a long fixed key in the pulley. The table is worked on the same principle as the ordinary horizontal—a variable feed, and has a quick forward and return motion. The slide is raised by power, and everything is brought within easy reach of the operator. The machine will take up no more room than the length of the slide.

NEW CANADIAN PATENTS.

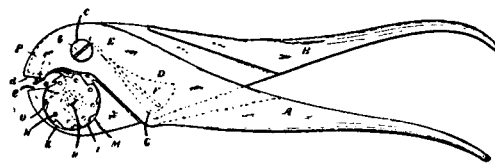

SAW SET.

Patentee: Mrs. Lydia Moyer, assignee of Samuel S^r Moyer and Alvin W. Moyer, all of Berlin, Ont., 13th May, 1895; 6 years.

Claim.—1st. A saw set, comprised of levers A and B, lever B having a cavity D, with a spring F secured therein, a disc K with a series of holes L, niches M and

cavities O in niches, said disc secured to lever B by a thumb screw H, a steel pin P secured in jaw d of lever A, substantially and for the purpose set forth. 2nd. In combination with levers A and B, disc K, thumb nuts and spring F, substantially as described.

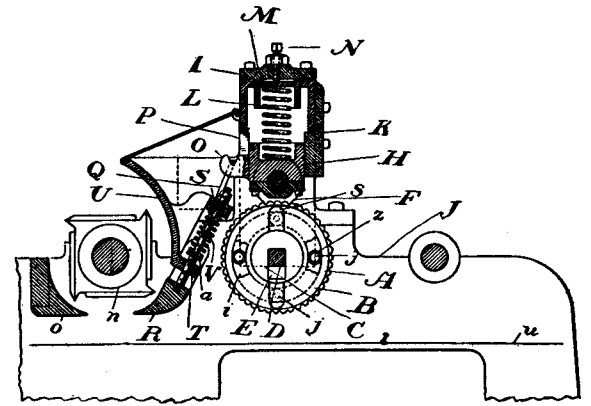

SECTIONAL FEED ROLLER AND PRESSURE BAR FOR PLANERS.

Patentee: MacGregor, Gourlay & Co., assignees of Thomas Cumming Robertson, and James McElroy, all of Galt, Ont., 21st, May, 1895; 6 years.

This is a patent in which there is a feed roller comprising a series of sections capable of rotating freely on sleeves carried by a fixed shaft and adapted to move vertically thereon; in combination with a pressure bar constructed in sections suitably supported and each connected with a corresponding section of the feed roller so as to move simultaneously therewith. In a feed roller is found the combination of the following elements: A series of feed roller section having grooves formed in each end thereof, a series of sleeves supporting said sections, a fixed shaft on which the said sleeves are vertically movable, a series of rings located between the sections of the rollers, a pair of studs connected to one side of the rings diametrically opposite to one another, a pair of studs connected to the opposite side of the rings at point intermediate of the other pair, the said studs entering the grooves in the ends of the adjoining feed roller sections and means for imparting motion to at least one section of the roller. In connection with the feed roller are also embodied other features that will give practical value to the invention. In a planer, a pressure bar comprising a series of shoes or independent sections sliding on lugs formed on a stationary bar in combination with adjustable springs suitably arranged to impart a downward pressure to the said shoes or sections, and spring pressure rollers suitably carried in vertically movable bearings and having hooks formed on the back of their bearings with which the said pivoted links engage, substantially as and for the purposes specified.

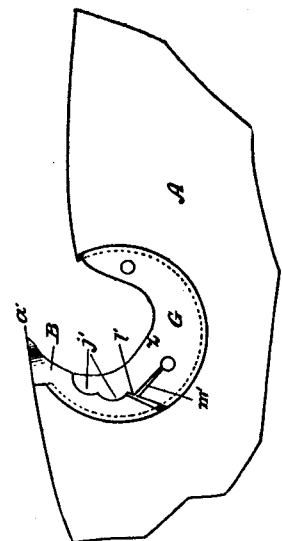

REMOVABLE SAW TEETH.

Patentee: Philius Bertrand, St. John, N. B., 20th May, 1895; 6 years.

Claim.—A removable saw tooth composed of two parts, namely, the bit or cutting part B, having formed in it the two circular recesses e', and point f' and the key part G, having the two circular projections j', holes h' and i' shoulder l', and slit m', all substantially as here-in shown and described.

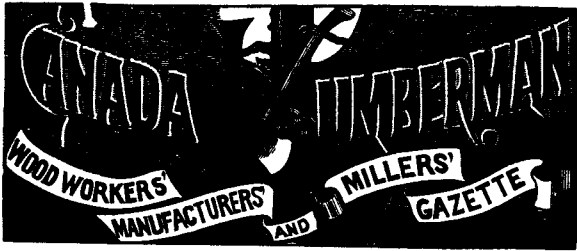

PUBLISHED ON THE FIRST OF EACH MONTH

—BY—

C. H. MORTIMER

CONFEDERATION LIFE BUILDING, TORONTO

BRANCH OFFICE:

NEW YORK LIFE INSURANCE BUILDING, MONTREAL

TERMS OF SUBSCRIPTION:

One Copy One Year, in advance \$1.00
 One Copy Six Months, in advance 50
 Foreign Subscriptions, \$1.50 a Year

ADVERTISING RATES FURNISHED ON APPLICATION

THE CANADA LUMBERMAN is published in the interests of the lumber trade and of allied industries throughout the Dominion, being the only representative in Canada of this foremost branch of the commerce of this country. It aims at giving full and timely information on all subjects touching these interests, discussing these topics editorially and inviting free discussion by others.

Special pains are taken to secure the latest and most trustworthy market quotations from various points throughout the world, so as to afford to the trade in Canada information on which it can rely in its operations.

Special correspondents in localities of importance present an accurate report not only of prices and the condition of the market, but also of other matters specially interesting to our readers. But correspondence is not only welcome, but is invited from all who have any information to communicate or subjects to discuss relating to the trade or in any way affecting it. Even when we may not be able to agree with the writers we will give them a fair opportunity for free discussion as the best means of eliciting the truth. Any items of interest are particularly requested, for even if not of great importance individually they contribute to a fund of information from which general results are obtained.

Advertisers will receive careful attention and liberal treatment. We need not point out that for many the CANADA LUMBERMAN, with its special class of readers, is not only an exceptionally good medium for securing publicity, but is indispensable for those who would bring themselves before the notice of that class. Special attention is directed to "WANTED" and "FOR SALE" advertisements, which will be inserted in a conspicuous position at the uniform price of 15 cents per line for each insertion. Announcements of this character will be subject to a discount of 25 per cent. if ordered for four successive issues or longer.

Subscribers will find the small amount they pay for the CANADA LUMBERMAN quite insignificant as compared with its value to them. There is not an individual in the trade, or specially interested in it, who should not be on our list, thus obtaining the present benefit and aiding and encouraging us to render it even more complete.

THE FUTURE OF PINE VALUES.

THE question of low prices of pine lumber is being discussed by lumbermen and in the lumber press. The apparent paradox presents itself, that with the growing scarcity of pine forests the prices of pine lumber continue low, with little tendency to stiffen. It is pointed out that whilst there was a period in the history of this continent when its pine forests assumed great proportions, yet these possessed comparatively little commercial value. Then there came the time when the country was opened out, railways were built, communities were established, and large cities grew apace. Building operations, under these conditions, became active, and pine, more than any other lumber, entered into consumption.

The value of white pine commenced to make itself apparent to shrewd observers. It was learned that no other timber filled the place that it did, and was so useful for many and various purposes. The demand grew. Capitalists saw a good investment in standing pine timber. Competition for possession of these lands was soon made manifest. As has been remarked by another, there is no value in stumpage unless a certain demand has been created for the lumber. This value had been created and stumpage values advanced rapidly, until within the past year or two, in our own country, these have reached a figure that makes it absolutely necessary that a reasonable price be obtained for the felled tree, if the capital invested is to be made pay a fair margin.

Here the question is raised, whether lumbermen who have paid high prices for the standing timber of to-day, will not experience difficulty in realizing nearly the same profit as had come to those who were owners of limits in the earlier days. Can the fortunes of the older lumbermen of this country be repeated? Some believe so. It is contended that white pine has become, and is becoming, scarce enough to give it a premium among the woods of the continent. The position seems safe, that in better grades of pine generous prices will prevail. In the older, and also the newer pine districts, the point has

been reached, however, where the felled trees will not cut in any large part to first grades of lumber. With a preponderance of common stock on the market prices in these grades are likely to depreciate.

To the extent that lumbermen who have bought standing timber at high prices must hold this to secure a paying price, will consumers be forced to look around for substitutes, costing them less money, and this is being done in the present day. Yellow pine is made a substitute for white pine to no small extent, where price is a consideration. Duluth lumber is coming on to the market, and as a new district, anxious to secure trade, the inducement of lower prices is being held out.

Other causes will enter into the conditions that will influence the price of pine. It is being remarked, that with an improving taste, and desire for better things, and better times will help largely in this direction, maple of second and third quality is being used now-a-days for flooring, where pine had been used before. Iron and steel are entering into building operations in an increased manner of late years, and any large growth in this direction will have its influence on the consumption of lumber. Substitutes in other directions, it may be expected, will take the place of lumber, and all these causes will go in a general way to regulate the price.

And so, after allowing for what has been said as regards pine stumpage and kindred considerations, it is, as a contemporary has remarked, "The prices of lumber will be determined by less occult causes, the importance of the supply in relation to the amount of the demand, the competition among different varieties of wood and among purchasers of wood under consideration, the effects of agitation and co-operation, of values, and a hundred other causes, which are only indirectly related to any such alleged cause as that advanced."

INTERPRETING THE LUMBER TARIFF.

THAT our readers may have a clear understanding of the ruling given by the United States Board of General Appraisers, touching the question of dressed lumber, we print the exact wording of the decision:

The merchandise consists of dressed boards on one side, with the edges planed or jointed and tongued and grooved. It was assessed for duty as a manufacture of lumber at 25 per cent. under Section 3, Act 1894, and is claimed to be exempt from duty as dressed lumber under paragraph 676.

From the evidence in the case it appears that the trade distinction of dressed lumber is lumber that is planed or surfaced on one or both sides, and brought to an even thickness. When it is further advanced in manufacture, by having the edges planed or jointed, it is no longer known as dressed lumber, but sheathing, casing, or by other names descriptive of the uses for which it has been prepared. When it has been subjected to the further processes of tonguing and grooving or beading, it is known as flooring, sheathing, ceilings, etc.

We find that the merchandise had been advanced beyond the condition of dressed lumber, and that it is a manufacture of wood. It is provided for under paragraph 181. The protest is overruled.

[Signed]

{ WILBUR F. LUNT,
THAD. S. SHARRETS.
J. B. WILKINSON, JR.

The question was raised by the exacting of 25 per cent. duty ad valorem on a shipment of lumber entered at the customs at Ogdensburg, N. Y. The lumber was planed on both sides, jointed, matched and beaded, and was classified by the customs officer as out of the free lumber list, and on the dutiable list.

No good will be accomplished by viewing this question other than in a liberal and equitable light. It is natural, perhaps, that a certain section of the lumber trade of the United States should hail the Appraisers' decision with delight, and in the current lumber journals letters are published from various lumber concerns and lumber districts, commending this decision. But this does not settle the matter, and the final settlement, we presume, will be through the United States Circuit Court, as was the case with the red cedar of British Columbia, judgment in which case is published in another column.

There are points in the decision of the Circuit Court re. red cedar that throw light on the present question of dressed lumber. There it is stated: "It was clearly the intent of Congress to exempt from duty all the cheaper grades of wood when rough, unmanufactured or partially manufactured, and to levy duty only upon the boards, etc., of the finer and more expensive woods used in cabinet work. This was the broad scheme of the Act of 1894." A measure like that of the Wilson

tariff can only be interpreted and made workable when taken in the broad and liberal spirit suggested by the words of the Circuit Court judgment.

The clauses of the Wilson tariff referring to lumber do not stand alone as the wording of the Act itself shows. They are dependent upon parallel clauses in the Canadian tariff, and to quote the Minister of Finance, when amending the lumber tariff, so as to meet the changed interpretation given of dressed lumber by the United States Appraisers, "In the preparation of the tariff last year the Canadian government had had the idea of reciprocity in respect to all articles on which this could be done and more especially in regard to lumber. For many years all had agreed that if it were possible to have reciprocity in lumber it was advisable to have it." This view is clearly endorsed by the Circuit Court, in their decision in the red cedar case in these words: "Again, it is apparent from the Act (par. 693) and similar provisions in the Canadian Act in the same year (section 13, par. 739, of customs tariff Canada), as well as from contemporaneous history, that the legislation of 1894 on this subject was entered into on both sides in a spirit of reciprocity. Neither country was to impose duty upon the coarser woods imported from the other."

The lumber press of the United States, when the tariff became law, so understood, and interpreted, the Act in the manner here stated, and it has only come in this case, as with red cedar, for a customs officer at a border point to call the Act into question. Judge Daniels, who was one of the most vigorous opponents of the Wilson tariff and especially watched the lumber clauses as they were passing through Congress, said, after the bill had become law: "When the bill was in conference I endeavored to get them to put an ad valorem duty on planed, matched, grooved and tongued lumber, but they did not pay the slightest heed to the arguments showing the necessity of such duty in order to protect our lumber manufacturers from the inroads that will be made upon them by the Canadian people."

Thus, of the intent of the law, there would seem to have been at the time of its making, no doubt whatever. The nice question raised now is, what constitutes dressed lumber? Or, in other words, where does dressed or finished lumber end, and manufactured lumber begin? The decision of the Board of General Appraisers states that "dressed lumber is lumber that is planed or surfaced on one or both sides and brought to an even thickness. When it is further advanced in manufacture, by having the edges planed or jointed, it is no longer known as dressed lumber, but as sheathing, casing, or by other names descriptive of the uses for which it has been prepared." Against this interpretation let us take the answer of Mr. G. W. Hotchkiss, of Chicago, the veteran lumberman and writer. In answer to a query of the Northwestern Lumberman, "What is dressed lumber," and what should be understood by "manufactures of wood," referring specially to the decision of the customs department of Ogdensburg, classifying flooring, etc., as manufactures of wood, he says that the legends and customs of the trade would not sanction such a decision. "If we go back," says Mr. Hotchkiss, "to the introduction of the planing machine, we shall find that the term 'dressed lumber' was applied to every variety of its product, whether the simple surfacing or tonguing and grooving, and this continued to be the universal nomenclature down to the days when the retailer of this city (practically the first to do it) introduced the various divisions and subdivisions in quality or grade into which his stock has since been divided, necessitating in the case of dressing, various terms to signify the character and extent of the dressing. Although flooring, ceiling, etc., are now ready for use in the main, they have yet to go through the manipulations of the carpenter, must be sawed to square end, and fitted to the place they are to occupy in the work, and cannot be called 'wholly manufactured' until thus fitted. From the earliest history of the trade the designation 'dressed lumber' has been applied, and the terms S 1 S, S 2 S, are but mere technical descriptions of the extent of the dressing. I remember that under the reciprocity treaty with Canada, 1855-1865, some of our customs officials for a time made claim that while 'saw-jointed' shingles were admitted free, 'knife-jointed' shingles were dutiable. Proper representation to the head of the department secured an

abrogation of this claim, as the shingle was no more a manufacture of lumber when trimmed with a knife than when trimmed with a saw, and was ready for immediate use in either case. Would a tongued and grooved (not surfaced) plank be "manufacture of wood" subject to duty as "dressed" lumber? I think not, and yet I have handled large quantities of it which was for the use intended just as much as a manufactured product as if it had been surfaced. The ordinary meaning of "dressed" lumber as defined by customs, includes flooring, ceiling and wainscoting as well as facing, which is but one degree of dressing, while others are carried a degree or two further. A manufacture of wood would be a finished product either in whole or in knock down, requiring no further manipulation in the way of fitting except the final finish of paint or varnish." Mr. Hotchkiss winds up his argument with the remark that if the term "dressed" had been defined by the authorities of the law to be confined to "surfacing," it is probable that the simple term would have been used; but in the use of the term "dressed" they but conform to the custom which has prevailed in the lumber trade from time immemorial. The present is the first time in an experience dating from 1847 that Mr. Hotchkiss says he ever heard it claimed that "flooring and the like was not properly classed as "dressed," rather than as a manufacture of lumber.

Manufacturers in Canada, who, like J. W. Howry & Sons, and others, have equipped their mills with special plants for dressing and finishing lumber, have reason to protest against the Appraisers' decision on the ground of vested interests, as well as from an intelligent and generally accepted interpretation of the law itself, as is pointed out in our remarks above. The very fact that the Messrs. Howry, a Michigan concern, should have made heavy investments in planing mill equipment in Canada, is good evidence of what was intended by the Wilson tariff. It is not easy to conceive that, as shrewd men of business, they would have made such an investment, had they not reason to believe that the tariff meant just exactly what Mr. Hotchkiss has stated it must mean. And so it is with others.

The hope is, as the Minister of Finance has stated, that in introducing a retaliatory clause into the Canadian tariff, it will be the means of promoting a friendly consideration of the case and a friendly settlement.

TRADE WITH FRANCE.

WITH the commercial treaty affecting the relations between Canada and France in respect of their customs and tariff now fully ratified, the Chambre de Commerce, of Montreal, is doing excellent work, in specially examining into the possibilities of development in all lines of trade between these countries.

Where France has been a fair customer for Canadian lumber, she has yet purchased under the old tariff, but a small percentage of her annual consumption. The exports of wood and manufactures of wood from this country to France in 1894 were as follows: Spruce and other deals, \$84,122; deal ends, \$6,902; planks and boards, \$14,168; lumber, \$2,279; square timber, \$7,318, and other miscellaneous manufactures of wood, \$2,893, or a grand total of \$117,682. The report on the Chambre de Commerce, giving in detail the importations of lumber to France in 1892, show that these amounted to \$40,000,000, and of these \$33,000,000 are represented in what is termed common timber, as distinct from cabinet woods, the class of timber that Canada is well able to supply.

From what source does France receive her lumber supplies at present? The question is answered in the report before us in these words. "As for instance the Scandinavian states, especially Sweden, heads the list with 50 per cent. of the whole, supplies with Russia nearly the totality of the imports of the English channel. Canada figures also with its paltry quantity. The same Sweden and Norway with Russia via the Black Sea supplies the ports of the Mediterranean, but this time in company with Austria, Hungary, Italy and the United States. Bordeaux and the ports of the Atlantic are supplied nearly exclusively by the hands of the last named country. Germany, a part of Austria, and Switzerland enter by land of the east frontier and supply the balance of the needs of the market in this district and in portions of the centre."

In the past there have been difficulties in the way of a large trade in lumber between France and Canada. The methods of doing business there are different to other countries, and especially Great Britain, with whose ways Canadian lumbermen are intimate. But this is simply a case of adopting methods suited to the country. The terms of the treaty place Canadian lumbermen on a perfectly equal footing with those of other countries. "It guarantees, to quote from the report of the Chambre de Commerce, "a reduction varying from \$1.25 to \$1.95 per 1,000 feet, B. M., and if by the efforts of interested parties direct and regular communication by steamer between the two countries can be secured, it would be ridiculously foolish not to profit by the circumstance, and abandon cheerfully, on account of a few difficulties that might be encountered at first, a vast and rich field of exploitation on the only ground of these being foreign competition."

We have on a previous occasion referred to the opinion expressed by Mr. J. B. Snowball, of Chatham, N. B., who said in his lumber report at the first of the year: "Twelve cargoes were shipped from this port to France during the past season, all to Marseilles, in the face of the disadvantage we are under as regards the import duty; but now that Canada is about to enjoy the favored nation clause under the recently ratified treaty a large revival of our exports to that country is looked for." And the Brooklyn Eagle of the 2nd Jan., 1895, alluding to the sale to an American syndicate of 860,000 acres of timber limits in Nova Scotia, said: "Agencies will be continued by the company in England, and new ones will be opened in the United States and in France and in South America."

The new treaty not only applies to France, but also to its colonies, and there is reason to believe that a good trade may be done with these also.

SOME LUMBER FIGURES.

IF we take the statistics of the lumber trade of Canada, as shown in the last report of the department of Trade and Commerce, it will be found that the exports of lumber for the fiscal year, ending June 30th, 1894, fall short of those of the year previous by rather more than \$1,000,000, though showing an increase over 1891 and 1892, but again behind 1890. The figures are: 1890, \$28,102,267; 1891, \$26,812,765; 1892, \$24,666,900; 1893, \$28,841,081; 1894, \$27,780,352.

Where this lumber has gone, in what quantities and ways, is an interesting question. The export of logs show up in large figures, and almost entirely of pine. Pine logs exported amounted to \$2,459,354, where those of spruce were \$107,282, and all others \$106,824. The United States, practically, were our only customers for logs, and as showing how these exports have grown from year to year, the following figures are suggestive. Total exports of logs in 1894, \$2,750,270; 1893, \$1,508,513; 1892, \$1,112,687; 1891, \$722,845, and 1890, \$681,265. How far it is wisdom on the part of Canada to ship her lumber in logs in such quantities is a question on which opinion divides. In his last annual address before the shareholders of the Merchants' Bank, Mr. Geo. Hague expressed the view that this large exportation of logs was an unwise policy.

The United States, happily, who were large customers for logs were still better customers for planks and boards, turned out of the saw mills of Canada, and it is a question whether exports in such quantities would have gone to that country, without the freedom in exportation of sawn lumber that has followed, and is a condition of, a free export of logs. The total exports of planks and boards for 1894, were \$7,964,970, against \$9,904,901 for the previous year; \$8,353,055 in 1892, \$8,963,434 in 1891 and \$2,104,577 in 1890. Of these the United States purchased in 1894, \$6,577,440; 1893, \$8,571,525; 1892, \$7,359,356; 1891, \$7,966,134 and 1890 \$6,977,697.

Coming to treat of another class of wood goods, to use the English term for lumber, it is learned that for pine and spruce deals the United Kingdom is an excellent customer. The exports of pine deals to Great Britain in 1894 were \$2,766,065; 1893, \$3,113,120; 1892, \$2,405,010; 1891, \$2,903,178; 1890, \$3,719,487. The exports of spruce deals far exceed those of pine, being as follows. 1894, \$4,925,640; 1893, \$4,255,006; 1892, \$3,710,627;

1891, \$4,402,446, and in 1890, which was the best of these five years, \$5,110,239.

The lumber of Canada finds a market, to a greater or lesser extent, in almost all parts of the world. The exports in planks and boards for 1894, to West Indies were \$184,480. Newfoundland took \$70,350 worth of planks and boards, \$88,500 in lumber, and some small purchases in other manufactures of wood, and the S. W. Indies \$172,073. The Argentine Republic, Australia, Africa, Germany, France, Spain, Portugal, Norway and Sweden, Belgium, Holland, Japan, Madeira, and other lands have all some acquaintance with Canadian lumber.

EDITORIAL NOTES.

THE semi weekly bathing of logs is something new in the history of lumbering, but this is being done on the Ontonagon river where the Diamond Match Co. cut last winter over 100,000,000 feet of timber, because of forest fires, which left the timber subject to the worms. These logs were put in the streams and what could be driven were sent down. About 80,000,000 feet were hung up. The water was very low in some places, and the only way to cover the logs was by the scheme devised for bathing. Though expensive, it will be better than losing the logs altogether.

THE theory, generally accepted as based upon scientific principles, that forests or the lack of forests, determine the amount of rainfall in a given area, is called into question by a contemporary in the light of the drought that has been experienced everywhere in the past two or three months. The untenable character of the contention is shown by a reference to the fact that the drought-scorched area has included many states that are heavily timbered. The existence of the forests in these cases has not helped conditions any more than where it was simply broad prairie, and the conclusion is that "the man who says that forest denudation is the cause of drought is yet up a tree." Alongside of statements of this kind may be read the story of the work of the Society of the Friends of Trees, an organization having its home in France, and whose special purpose is to promote re-forestation for the purpose of regulating the matter of rainfall and preventing drought, and other injury that it is alleged comes to a country where the work of the denudation of its forests is indulged in. It not unfrequently happens that the beliefs, that seem the most fixed with individuals, are completely knocked out at times by the matter-of-fact experience of the day.

IT is reported, that in Duluth, lately, lumber dealers threatened to boycott any builder or architect who should specify Washington fir in any public buildings. The purpose, doubtless, was to make it necessary that home timber should be used. Where it can be shown that for certain well defined reasons it is unwise to import foreign woods to be used in public buildings, the lumber trade owe a duty to themselves and their district to point out these drawbacks and bring all reasonable force to bear preventing their use. But let reason in all cases prevail. The boycott is a measure wanting in courage. It may be said, it is the coward's weapon, whether used by workmen, manufacturers, or any one else. In fact, so far as lumber is concerned, it is almost impossible to talk of excluding any particular class of lumber from any particular district or country. No article of merchandise is so thoroughly cosmopolitan in its character as lumber, and the trade is becoming more so every year. Washington fir, or what is known in this country as the Douglas fir of British Columbia, is especially suited for certain work, and the world over, those who want the best lumber for shipbuilding, and in other cases where great strength and endurance is required, will be obliged to secure Douglas fir. In the Transactions of American Civil Engineers is published the following tests of woods. White pine broke at 3,872 pounds, all same sizes. Norway pine broke at 4,008 pounds, all same sizes. Douglas fir broke at 6,214 pounds, all same sizes. In other words Douglas fir was shown to be by a large percentage stronger than the strongest woods. This wood is becoming well known lately in its uses for bridges and other public undertakings. Some unusually large pieces have been sent east to Montreal to be used for dredger work there.

NEW BRUNSWICK LETTER.

[Regular correspondence CANADA LUMBERMAN.]

RATHER more than midway into the year lumbermen are congratulating themselves on the splendid business that has been done this season compared with other years. The opening of the United States markets has helped to swell the volume of trade into important figures, and it has been usually of a profitable character. The Consular's figures of trade between St. John and the United States for the year ending June 30th show as follows: First quarter, \$261,950.01; second quarter, \$335,197.16; third quarter, \$109,658.73; fourth quarter, \$696,735.23, or a total of \$1,493,541.13. It will be seen that the shipments of the last three months cover nearly half of the shipments for the year. What this growth means will be recognized when it is stated that shipments from St. John for the year ending June 30th, 1894, were only \$319,322.69. British trade has, of course, been regulated by conditions in the United Kingdom, and these have not been of the most satisfactory character, and yet a good trade has been done, and represents a fair margin of profit.

The Hamilton mill at Straight Shore is rapidly nearing completion.

An addition has been made to their saw mill at Spruce Lake by Hanson & Miller.

Lumber exports from Parrsboro, N. S., for the month of June were \$189,116.

G. G. and W. C. King are making extensive repairs to their saw-mill at Summerhill, N. B.

The saw-mill of H. A. McPhee at Henry Lake is represented as being particularly well equipped and doing a splendid business.

The mills of W. C. Purves and A. Cushing & Co., which were destroyed by fire will be rebuilt, the city council granting aid to the former by wiping out the last year's taxes, and in the case of the latter will extend the water service to the site of this company.

St. JOHN, N. B., July 24, 1895.

BRITISH COLUMBIA LETTER.

[Regular correspondence CANADA LUMBERMAN.]

SEVERAL circumstances, though varied in character, have created interest in lumber affairs on the Pacific Coast within the past month. One of these has been of a decidedly depressing nature, namely, the destruction by fire of the Brunette saw mills, at Sapperton, near New Westminster, and already noted in the columns of your weekly edition. The Brunette mills occupied a large place in the lumber concerns of British Columbia, and perhaps at no time in their history was business in a more prosperous and progressive state than this season. The fire broke out in the dry kiln and spread with alarming rapidity, it not being long before the entire mill was destroyed. Mr. Wilson, manager of the company, estimates the loss at fully \$75,000 over the insurance, which will have to be borne by the stockholders. The financial position of the company is excellent, as all the stock issued is fully paid up. The liabilities, outside of the company's liabilities to the stockholders, are not large, and everything will be fully paid. The fact that for some time past the company have had orders booked more than a month ahead of the output, and cargo after cargo has been refused, will indicate how unfortunate the disaster is, and at what an unfortunate time it has overtaken the company. At this writing I am not able to say whether or not the company will rebuild. The stockholders, to a large extent, consist of prominent Ottawa lumbermen and others in Ontario and Quebec.

J. C. Anderson intends building a saw-mill at San Juan, Vancouver Island.

The settlement of the red cedar difficulty, placing this lumber on the free list, is an item of decided congratulation among the lumbermen of British Columbia. There can be little doubt but that large shipments of this lumber will from this out go into the United States.

A shipment of lumber that left here within the month for Shanghai, included an unusually large number of heavy sticks. The dimensions of the largest are as follows: 4 spars, 24x24 inches square and 100 ft. long; 4 pieces, 24x24 inches, 90 to 102 ft. long; 6 pieces, 25x20 inches, 90 to 100 ft. long; 12 pieces, 18x8, and 17 pieces, 16x16 inches, 80 to 100 ft. long.

After much waiting the lumbermen of British Columbia have finally got together and decided on an increase in the price of lumber of from \$2 to \$3 a thousand feet. Though the volume of trade on the Coast has kept up well for some time past, this encouraging feature has been offset by the low price at which much of the lumber in the past has been sold. The hope is that an advanced price has now come to stay.

Mr. K. H. Alexander, manager of the Hastings mills, who has lately returned from an extended trip in Great Britain and other foreign markets, is hopeful that Douglas fir will eventu-

ally find a large and profitable sale in the foreign markets. This pine for some time has been known on the English market as Oregon pine, but this is a matter that Mr. Alexander and others are having righted, and we shall in the near future learn of Douglas fir as one of the woods, I anticipate, well known in the United Kingdom. The low price of pitch pine in Great Britain has been a barrier to the introduction of Douglas fir in the past, but time also will overcome this difficulty. Mr. Alexander reports that upon the continent he found Douglas fir giving good satisfaction, and when on the Clyde he saw a cargo of lumber from the Hastings mill, that seemed to give particular satisfaction to English lumbermen.

NEW WESTMINSTER, B. C., July 23, 1895.

MICHIGAN LETTER.

[Regular correspondence CANADA LUMBERMAN.]

LUMBERMEN in this district, viewing the matter from a purely personal standpoint, express themselves as pleased with the recent decision of the Board of General Appraisers in excluding matched lumber from the free list. Questioned as to the real interpretation of the Act, and what was meant by its promoters, many will be frank in saying that the Wilson tariff was intended generally to cover the classes of manufactured lumber now disputed.

Lumber business generally is quiet, but the disposition is to charge it to the midsummer holiday season.

A large raft of cedar containing 12,000 telegraph poles, 25,000 cedar ties and 50,000 posts was rafted down the Detroit River to Delray a week ago for the Cleveland Cedar Co.

Extensive timber fires have been prevalent in different parts of the State and a good deal of damage done. One result is quite sure to follow, and that is that the price of hay and coarse grains for lumber camps next year will be high.

A statement is made by lumbermen here that logging on the Canadian side of Lake Huron costs 25 per cent. more than on this side and as a consequence jobbers who took contracts based on cost of logging on this side will come out at the short end.

SAGINAW, Mich., July 26, 1895.

SOMETHING ABOUT INJECTORS.

HINTS ABOUT THEM FOR ENGINEERS AND FIREMEN.

IN some instances it may be found impossible to adjust the injector for the work required, as it may have been especially for a far different pressure than that at which you wish to work it, for the higher the steam pressure used the smaller in proportion must the steam tube opening be, and no injector can be made which will fit all conditions equally well, regardless of advertisements to that effect.

Suppose our injector acts as we have stated before, we immediately know that it is not the fault of the injector, for if it was it would not start at all, unless in rare cases there may be a tube loose, and after the injector has started this may move and alter the relation between the water and the steam supply.

If our injector does not receive steam from the same pipe, the engine does, and the boiler is not forced to such an extent that it lifts the water badly we may neglect the wet steam cause and look for others. First of all, we will make sure that our water supply is not interrupted by some unknown cause, for this would cause a deficiency of water and the steam would show at the overflow, making the injector break. This water deficiency may be caused by the water valve having a loose disk, which may move on the steam enough to alter the opening for water, and this is a fruitful cause of trouble many times both in steam and water pipes.

Or it may be that a pump in the neighborhood is taking the water at intervals, and at times the lessening of water may be enough to cause a "break" in the injector's working. Other causes which give trouble may be given briefly:

In many instances the pipes leading to the injector are long and small and often filled with rust and other deposits, and while the injector will start all right it breaks just as soon as it has used the amount of water that is in the pipe, for this acts as a reservoir, supplying water enough for a start, but being soon exhausted.

In a case of this kind it will not do to blame the injector after being sure that there is nothing loose about it, for if it will start it will run until worn out, unless stopped by some outside cause and this cause must be looked for.

In cases where small injectors are used on large pipes

confusion often arises as follows. The injector will start all right, and after a very short period of operation will suddenly break and we wonder why. In case that have come under my notice this has been caused by there not being an opening into the boiler, the check being either stuck or the stop valve shut. The injector starts well enough, but after it gets the large pipes filled and the pressure rises to the limit of the injector, then a break. A long pipe between injector and boiler, even if not so large, will have the same effect.

Great difficulty will sometimes be experienced in starting an injector, and one of the most common causes for this is a leaky check valve, allowing hot water from the boiler to come back into the injector and boil the water, or prevent it from condensing the required amount of steam. This can be readily found by care, carefully noticing whether any hot water shows at the overflow when the steam supply is shut off; this will indicate a leaky check valve unless the steam valve leaks, and a little care will soon determine which is the leaky valve.

The checks that give the most trouble are what are termed straight way, or swinging checks, which, while very good for some work, are not as good for injector work as the old-fashioned plain check. The reason is this: The passage of water through them wears the side of the seat farthest from the hinge and in a very short time the check is not tight, and this little leakage back from the boiler makes it hard to start the injector. And if a very slight obstruction becomes lodged near the hinge, the opening at the outer end of the swinging valve is much greater and the leakage is considerable. This is not said to injure any maker of swinging checks, but merely to give my own experience in this class of work.

When you have your doubts as to the quantity of water that can be supplied to the injector, just measure the flow by letting it run into a measure of known quantity and note the time taken to fill the measure. If we have a two-gallon pail and the water from the supply pipe of the injector will fill it in five seconds, we know that as there are sixty seconds to the minute the pail will be filled twelve times per minute, which is twenty-four gallons a minute or 24x60 equals 1,440 gallons per hour.

In many cases the injector is made useless by the manner in which the piping is put up, and the writer has found cases where the injector refused to work, in which the supply of water had been cut down to less than half by the man who did the piping screwing all the pipes so far into the valves and elbows as to almost close the openings. This is particularly apt to be the case in the valves and checks, as the brass of which they are made gives so much more than iron fittings that the men do not stop until the pipe refuses to turn with the same force that they apply to iron pipe fittings. A little judgment helps wonderfully in a case of this kind. It is sometimes necessary or convenient to pipe the injector to the same supply and delivery pipes as used by the pump, although it should never be done where both are to be used at the same time, as the pulsating action of pump is very apt to take the water from the injector momentarily and cause it to break.

Where this is done there should be valves so that the pump connections can be shut tightly from the injector and vice versa, particularly in the case of a lifting injector. One instance of this kind was brought to my notice aboard of a little yacht which was being hurriedly fitted for a southern winter cruise, and in which the injector would start nicely and work for a minute perhaps, and then break or fly off, as some call it. The first thought was that there was a piece of wood or waste floating in the water tank in the bow of the boat, and that the action of the water drew it over the pipe and shut off the water supply, as often happens in cases of open tanks. This was not correct, however, as investigation showed that the men who had piped the injector had connected the water supply to the same pipe that supplied the wash basins in the cabins, and whenever the faucets in the cabins were open or leaked the air was drawn into the pipe and into the injector, and caused the break. By piping the two water supplies separately the trouble was remedied and the boat was ready for her trip in tropical climates.—The Tradesman.

RED CEDAR FREE.

JUDGMENT OF THE UNITED STATES CIRCUIT COURT IN FAVOR OF
BRITISH COLUMBIA CEDAR.

THE history of the red cedar trouble of British Columbia will be remembered by readers of the CANADA LUMBERMAN. Some months ago a shipment of red cedar lumber from British Columbia to a United States port was taxed at 25 per cent. ad valorem, being included among the list of cabinet cedars, chargeable with a 25 per cent. duty. Largely through the efforts of Mr. J. G. Scott, manager of the Pacific Coast Lumber Co., of New Westminster, the case was laid before the Board of United States General Appraisers at New York. The matter was very fully entered into, a report in detail appearing in these columns at the time. The decision of the Appraisers was against the contention of the British Columbia lumbermen that red cedar was a soft wood and should not be classified as a cabinet wood. The matter, however, was not allowed to remain here, but was appealed by Mr. Scott and associates to the United States Circuit Court. Judgment has just been given out by the Court, and reverses the decision of the Board of General Appraisers. The importance of the decision to British Columbia lumber interests is apparent to everyone, as there is undoubtedly a profitable market for British Columbia red cedar in various parts of the United States, and shipments to that country have only awaited this decision.

The judgment is clear and decisive, and based, not alone on law, but on a very commonsense view of the situation. We here give the judgment of the Court in full:

UNITED STATES CIRCUIT COURT, }
Northern District of New York. }

In re F. W. Myers & Co.

This is an appeal by the importers for a decision of the Board of the United States General Appraisers overruling a protest against the decision of the Collector at Plattsburgh, N. Y., subjecting to duty certain importations of lumber popularly known as Red Cedar.

Stephen G. Clarke for the importers.
W. F. Mackey, Asst. U. S. Attorney, for the collector.

Coxe J.
The collector classified the merchandise in question under paragraph 181 of the Act of August 28, 1894, which is as follows:

"House or cabinet furniture, of wood, wholly or partly finished manufactures of wood, or of which wood is the component material of chief value, not specially provided for in this Act, twenty-five per centum ad valorem."

The importers protested, insisting that it should have been admitted free of duty under paragraph 676 of the same Act, which is as follows:

"Sawed boards, plank, deals and other lumber, rough or dressed, except boards, plank, deals and other lumber of cedar, lignum vitae, lancewood, ebony, box, granadilla, mahogany, rosewood, satinwood, and all other cabinet woods."

The Board found that the imported lumber is from the wood of a tree known botanically as "Thuya Gigantæ," and that it is popularly known as "red cedar," or "canoe cedar." It is soft, light, but slightly fragrant. It does not take a polish. It is not of the class of woods known as cabinet woods. The other woods mentioned in the exception are hard, expensive cabinet woods used in fine finishing work. If the exception to paragraph 676 refers to cabinet woods, and only to cabinet woods, it is manifest that the importation, not being cabinet wood, is not within the exception.

The Board were inclined to sustain the protest upon this ground, but reached a different conclusion after construing the paragraph in the light of paragraph 219 of the Act of Oct. 1, 1890, the argument being that because in the prior Act the word "Cedar" included rough lumber such as railroad ties and telegraph poles, a similar meaning must be given to the paragraph in hand, and that it cannot be restricted to that species of cedar used as a cabinet wood.

The clause in question is certainly ambiguous, and although much may be said in favor of the view taken by the Board, it is thought that the construction contended for by the importers is supported by more cogent and persistent reasoning.

In arriving at the legislative intent it is not altogether safe to rely for guidance upon the Act of 1890, it being common knowledge that its object was very different from that of the present Act. An examination of the former Act will show that practically the entire wood schedule has been transferred to the free list in the present Act.

It seems clear that it was the intent of Congress to exempt from duty all the cheaper grades of woods, when rough, unmanufactured or partially manufactured, and to levy duty only upon the boards, etc., of the finer and more expensive woods used in cabinet work.

This was the broad scheme of the Act of 1894. The construction of the Board ignores this intent and levies a higher duty upon cedar boards than the Act of 1890, and this, too, when similar boards of spruce and pine, used for the same purpose, are admitted free. It discriminates against the boards of one particular soft-wood tree without the suggestion of a motive for such legislation. When boards used for sidings, etc., are free, what possible reason could Congress have had for singling out and laying duty upon these boards when sawed from one particular variety of tree? It is as difficult to find a

plausible motive as if Congress had discriminated against the boards cut from coniferous trees. Again, two pieces of wood are cut from the same tree; the one pays twenty-five per cent. duty, the other enters free; one—a shingle—is used to protect the roof, the other the side of a dwelling-house. The construction of the importers makes such a result impossible, gives force to every part of the paragraph and is in harmony with the general purpose of the law.

It is proved without dispute that all the other varieties mentioned in the exception are cabinet woods—the products of foreign countries—and the Board finds that the cedar known as "Cedrela Odorata," which is imported from the tropics, is a cabinet wood of the mahogany family, and is capable of taking a high polish. It is a very significant fact that this Cedrela, besides being a cabinet wood, is the only wood in the United States which is known as "cedar" pure and simple. All the other varieties have some qualifying term placed before them, such as white cedar, Spanish cedar, red cedar, etc. Finding cedar thus associated with eight well-known cabinet woods, the rule of ejusdem generis requires that the word should be construed as applying to that variety of cedar which is a cabinet wood. So construed the exception applies to hard, expensive, foreign cabinet woods, and to these alone.

That this is the true reading of the paragraph is made still more apparent by the use of the word "other." When the law-makers at the end of the paragraph refer to "all other cabinet woods," it is not clear that they supposed all the preceding varieties were cabinet woods and that they did not intend to include in this enumeration a wood that is no more a cabinet wood than is white pine or hemlock?

Again, it is apparent from the Act (par. 683) and similar provisions in the Canadian Act of the same year (sec. 13, par. 739 of the Customs Tariff, Canada) as well as from contemporaneous history, that the legislation of 1894 on this subject was entered into on both sides in a spirit of reciprocity. Neither country was to impose duty upon the coarser woods imported from the other. The construction of the board is at variance with this obvious intention.

The importers' contention is further strengthened by the construction placed upon a similar provision in the Act of 1883 by the Treasury Department. It was held "that the provision for wood, namely, cedar, lignum vitae, lancewood, ebony, box, granadilla, mahogany, rosewood, satinwood, and all other cabinet woods, unmanufactured, is construed as exempting from duty only such cedar as is fitted or intended for use as cabinet wood." It will be noted that the paragraph quoted is not so explicit as the paragraph in controversy, in that it omits the word "other." It was said at the argument that this construction of the Treasury was acted upon for many years.

In conclusion, it is thought that the decision of the Board is based upon a strict construction, which leaves out of view the real intent and purpose of the law. To say the least, the construction which makes the word "cedar" include all the varieties of soft, coarse wood known by that name, is a doubtful one. In such cases the doubt should be resolved in favor of the importer, "as duties are never imposed on the citizen upon vague or doubtful interpretations." (Hartranft v. Weigmann, 121 U. S. 609, 616.)

The construction asked for by the importer makes the paragraph consistent in all its parts, is in harmony with the general purpose of the Act and with the principles of international fair dealing.

The decision of the Board is reversed.

SOME SAWING HINTS.

A GOOD many little things turn up in the course of turning logs into merchantable lumber which, if they could be formulated into a set of rules, would help the young sawyer or the newly-fledged lumberman out of a large variety of perplexing situations, says the Wood-Worker.

When a log comes on the carriage, it is often a puzzle to tell just which side to begin sawing on first. I have had a good many years' experience in saw mills, with almost every kind of timber that is made into lumber, and I believe a man can be a mill foreman or pull the lever all his life and be as quick-witted as you please, and still find things to learn about handling logs clear up to the time the whistle blows for him to quit for the judgment day.

There are a good many things about turning a log so as to get the most good stock out of it, that cannot be done by rule, and that the wisest sawyer cannot tell to another. There are things that have to be learned of every log; for, as Harry B. Wetzell often said, "Nature never had two trees, or even two logs, exactly alike." This rule is at least so nearly correct that "the exceptions only prove the rule." A sawyer may work ten or even eleven hours and not have two logs alike come on the deck.

This is especially true of hardwood logs, which vary in characteristics in an aggravating manner. But there are some things that can assume the proportions of exact rules. For instance, a sawyer asks how to place for a first slab, a log, surface clear with the exception of a single defect. The answer is, slab the log with the defect exactly in the center of the width of the cut; then slab the opposite side and turn the log with the defect exactly on top, perpendicularly to the heart; then saw up to a well-boxed heart, if it is a kind of timber fit for

squares or dimension; then turn clear over and saw up the same on the opposite side; turn down with best edge of cant to saw; cut up to square; then set out full size of square and rip it off; turn remainder of cant perpendicular with defect on top as in first place, and finish with the latter in one cut, or most two.

This will necessitate a little extra turning and a little more time in sawing the log, but when through all the lumber will be clear of everything but sap, except the one or two narrow pieces containing the one defect. If no square or dimension is wanted, then saw up to the defect on the one side and turn clear over and saw upon the other, letting the edger do the rest; every inch of clear stock in the log can be edged out with no waste and the very minimum of lumber not clear.

I have seen sawyers put such a log as this on, and after slabbing all around, turn the side with the one defect square to the saw and slash away to the last cut, making one-half the boards with perhaps a rotten knot right in the center, requiring them to be ripped twice to get out the good lumber, and so getting but little more than one-half the wide boards that could have been made by the directions I have given. And these sawyers were called good ones, too, and their bosses were wondering at the small per cent. of clear and wide lumber their logs turned out.

Butt logs with much taper should have the top end set out so as to slab parallel to the outside, and not to the center or heart of the log. Such a log is generally wind-shaken. The shake is conical, largest next the stump, hence by sawing parallel to the outside of the log, and by sawing round it, turning as soon as the shake is reached, all the clear lumber can be gotten out and all the shake be left in the tapering square in the center, which is seldom worth anything but firewood or to go to the refuse burner. In any event, sawn in this way the stock will be straight-grained, which it cannot be if cut parallel to the heart.

Some sawyers fail to catch their point and set the tops out to bring the center or heart in line with the saw, and if by the time the log is slabbed to the face the full length, all the clear stock from the butt end will have gone into chips, or out in an enormous slab; and after that every full-length board will be shaky at the butt end, requiring them all to be trimmed or graded as culls, and all if trimmed shorter than standard length or made into mere clips—and the boss would curse the logs instead of the sawyer.

Crooked logs are often puzzles to the best of sawyers. Many take a log with a straight bow, and put it on the carriage with the rounding side up, or exactly down. The latter is a dangerous thing to do, and many a good saw has been spoiled by it. Others place such a log on the one side with the back of the bow to the saw, and make a lot of clips or short lumber while getting a slab the full length. There is only one better way to do, and that is to place the bow at an angle of 45 degrees to the carriage, and after slabbing one side, turn clear over and finish. This will give more wide lumber than any other way from such a log. Try it once and see.

Hearts in all logs are more or less a source of trouble, but much less in pine or other soft woods, except hemlock, than in nearly all the hardwoods. In the latter they are nearly always an uncertain quantity. In sawing hardwoods it is a safe rule to make a large allowance for waste on account of them. It is a weakness of the sawyers and edgermen not to allow enough for them. This accounts for a large percentage of culls in the cutting of many species of timber, such as oak, cherry, birch, soft elm, and maple, gum, cottonwood, basswood, ash, rock elm, hickory and even poplar might come within the category. In oak and some other woods it is productive of better financial results to make sure of a good square of timber with a well boxed heart in the center, than to try to saw up too close and then edge the heart butt. In the latter case the quality of the boards is risked and the square is often not worth shipping.

A final excellent rule to always keep in view is, that a large daily cut is not of nearly so much importance as well sawed lumber, with the highest possible percentage of good grades.



WHERE there is talk about dull times in the lumber business, the report comes from Duluth that every mill there is sawing at a lively rate, and the total output for the district will be about 100,000,000 ft. in excess of any previous year. It looks like a conundrum how facts of this kind are to be squared with the general talk of quiet business. If trade is slow now, and there is more lumber on the piling grounds than it seems possible to move, what will be the condition of affairs when the new cut is upon the market? I talked the other day with Mr. Joseph Oliver, Alderman Oliver, if you please, of Donogh & Oliver, who had returned only a few days from a trip through the Eastern States. He could only tell the story, that everyone is telling, of business being dull. No one wanted to buy, and no one seemed sure just what the future was likely to bring. He said that so far as his firm was concerned, they were buying hardly anything just now, and, as Mr. Donogh added, at no time since they were in business, had they so large a stock of lumber on hand at this season of the year. I enquired what was the effect of such conditions on prices. "Nominally," said Mr. Donogh, "there is no change. Prices are considered to rule firm, but when it is a case of being actually ready to buy, it is a different matter, and it is easy to understand this with our own mill men, as well as those in the States, carrying stocks in some cases of two and three years, and the new cut about ready to put on the piling grounds." Where a place is to be found for this lumber seems hard to say, and what it means in the way of interest for mill men to carry two or three years stock is easily seen. The lumber business appears to be changing in many ways, and lumbermen are disposed to do a good deal of thinking these days, without saying much. It is not possible for new districts like Duluth to increase their output to the extent of 100,000,000 feet, and everyone else keep up a fair average, and lumber not be forced to move in some manner. But, as Mr. Oliver said, in his good-natured and hearty way, it will come all right some of these days, and for his part he was rather growing grey, losing flesh, or wanting sleep.

* * * *

It is to be expected that one would find Canadian lumbermen discussing the recent decision of the Board of General Appraisers of the United States, in drawing a somewhat sharp line as to what constitutes dressed and finished lumber. As regards the action of the Minister of Finance, in passing a retaliatory measure before the House prorogued a fortnight ago, I find that this is generally conceded to have been a wise step. The lumber tariff was framed on a reciprocal plan, and so long as the United States draws the distinction that the Appraisers have made in dressed lumber, it would be unwise for Canada to simply let the matter remain there, and allow American lumbermen to export matched and grooved lumber to this country without any duty charged. Where this matter is of interest to the Canadian trade is not in what business has already been done, but the possible development of the future. So far as I am able to learn there has been no large amount of matched lumber exported to the United States, as yet. It is a fine question, what actually constitutes manufactured lumber. To quote Mr. Meaney, of Robert Thomson & Co.: "The log when sawed into rough lumber has passed through a manufactured stage. Plane it on one side and it is a little further manufactured, but yet it is simply manufactured lumber. Who is to say that because grooved or tongued, as well as planed, that a customs officer shall step in and take it from the free list and put it under the duty list. My understanding of manufactured lumber is when it has been made into sashes, doors, blinds, etc." There is another feature of this question, I find lumbermen speaking plainly of, and that is that these customs difficulties occur through

the ruling of a customs officer and not because of objection at headquarters. The law ought to be made so clear, that it could not be left to one who cannot have any technical training to decide what it means. There will be no end of trouble with our tariffs if, as in the case of the British Columbia red cedar and the present Ogdensburg difficulty, customs officers everywhere can constantly call some point into question. Then, and it seems to me clear that the makers of the law never intended that the Ogdensburg distinction should be made, where Canada will doubtless export a certain measure of grooved and tongued lumber to the United States, on the other hand United States manufacturers are sending in this class of lumber to our own country. A not unprofitable customer at the present time is the people of Manitoba and the Northwest territories, who import no little manufactured lumber of this class from the western states.

* * * *

WITHIN the past month Mr. Campbell, of the Muskoka Mill and Lumber Co., has returned from a visit of some weeks in the Maritime provinces. Finding pleasure, as everyone does who visits this section of the Dominion, especially in the summer months, he yet went east on business. His firm own considerable tracts of spruce lands in New Brunswick, and their expectations and hopes of that class of lumbering become stronger the more they know of the country. I cannot think of any line of trade more interesting to study than lumber, and especially to Canadians. The developments in wood manufacture and the uses to which woods are being put are so many and constantly widening that the person who has an interest in this work finds much that is suggestive and attractive. It is hard to say what will be the final outcome of the spruce trade in this country, so rapidly is the business growing, and especially the wood pulp side of the business. Mr. Campbell found the lumber business in good shape in New Brunswick, the season being an unusually busy one. The volume of trade will run largely in excess of that of former seasons. I asked him if any great difficulty was being experienced by loggers through drought in that province, and his reply was that logging there, compared with like work in Ontario, was a simple and easy matter. The country was not broken up into small streams, such as are met in Ontario, and consequently a dry spell does not tie up logs as it will here.

* * * *

How easily an individual circumstance will change the entire trend of trade is clear to every observant man. Take any section of country. Take the province of Ontario, and go over the history of its towns. See here and there a town which at one time was in flourishing condition, the centre of manufactures and everything booming. Fire or financial disaster has removed the leading manufacture of the town, or inducement has been held out by some other municipalities and a change of site is decided on. The town quickly collapses and soon becomes known as one of the dead places of the country. I shall not mention names of places, or I would get some of my editorial brethren of the local press after me with a long stick, or rather sharp pen, but they are known to everyone. What havoc the railroad has created in this way. Planting its workshops and running its extensions into certain towns everything progressed. Then in the most callous manner these shops have been removed, and the stopping point has been shifted further along the line and the town goes down. We see a good deal of this kind of thing in the lumber trade. Every little while a wail comes up from some of our northern towns that they are being ruined because saw mills are closed down, and the blame is often thrown on the tariff, or made chargeable to the unwise action of some public man. These whilom lumber towns are just in the same box as the manufacturing towns I have been speaking of, and the charge wants to be made to the constant change that is a feature of commercial life and which it is sometimes hard to analyze. There are towns where the saw mills were once the life of the community, that are dead to-day because they are too far away from the logs. In the early days of lumbering they were beside the forests, but as lumbermen have cut into the interior they have gradually and certainly got away from them. I have thought of another illustration

in this line in the manufacture of box stuff, caused by the Standard Oil Co. giving its trade this year to North Carolina pine. This trade amounted to the consumption of 150,000,000 feet annually; a change to southern pine was a hard thrust for white pine, but the box trade will survive it. These changes may hit each one of us hard sometimes, but the business man needs to view such questions broadly, and have resources enough to shape his business and get on to other lines of trade and methods.

* * * *

A DIRECT injury that may come to lumbermen by a continuous dry season, such as has been experienced this year, in almost all parts of the country, is the "hanging up" of large numbers of logs through want of water in the streams and rivers. Or again, the greater disaster will come from forest fires, and it is to be regretted that neither in Canada nor in the lumber districts of the United States, has there been entire freedom from loss in this way this season, though this has not been as severe as in some other years. The drawbacks of the present drought, however, will not end here with lumbermen. In a short time they will commence to make preparations for the work in the woods, some of the Ottawa firms already sending advance gangs on to start the work of another season. Hay will be wanted for the horses, and it will be found scarce and high in price because of the drought. Other coarse grains and feed that are a necessary part of the supply of every lumber camp will be found almost equally scarce and in this way the cost of logging another season will be to some extent increased.

* * * *

IT is a very sure index of an improvement in lumber conditions that a strong desire exists among lumbermen in all branches to advance prices. It has been made plain, we think, in another column, that so far as the owners of standing timber are concerned, they must clear on the whole, a better average of prices than has obtained for the past two or three years, if any profit is to come out of their transactions. Manufacturers in wood-working lines have been doing business almost for the fun of the thing, and that they are now thinking of the lines of putting an advance on the manufactured products is hopeful. They must do this, if interest, and less profit, is to come from the capital invested. In Canada the stand taken by British Columbia lumbermen within the month ought to be inspiring. There was need for the change, but it called for courage all the same, to advance Pacific Coast lumber from \$2 to \$3, a thousand. Spruce men in the Maritime Province acted earlier than those in British Columbia, and though it looks just now as if the prices of some months ago would not hold continuously, still a brave fight is being made to adhere to the schedule of prices already fixed. It is going to be an interesting question how far shingle manufacturers will be able to fall in line with other lumber manufacturers in securing an advance in prices. Relatively, the shingle trade, whether in white pine, spruce, or red cedar, has been more demoralized of recent years than any other branch of lumbering. With all that the term means the shingle trade has gone to the dogs. Prices of white pine shingles in Ontario will be helped by the reduction that has taken place this year in the manufacture. Not a few mills that have, in some cases, made a leading feature of shingles, as well as those with whom it has been an incidental part of the trade, are this year making no shingles at all, and others are curtailing the output considerably. This would seem to be the wisest course that could be pursued to bring conditions back to a normal position. The truth is that with white pine shingles, always a leading article, and the prodigal manner in which lumbermen both in British Columbia and in the Washington territory have entered into the manufacture of shingles, has meant that the production of recent years, even if times had been good, far exceeded the possible demand. Who will, for a number of years, and indeed for all time, go out of the business? It would pay red cedar manufacturers to form a combine, buy up the percentage of the shingle mills of the country, stop the wheel-running, and turn the buildings into some other uses. Like other heroic measures, though, perhaps, distasteful, these would be successful and prove a healing and curing remedy.

THE NEWS.

F. Chant will erect a shingle mill at Chantry, Ont.
 -J. Hodgson is erecting a saw mill at South Finch, Ont.
 -Wm. Smyth will erect a saw and shingle mill at Bensford, Ont.
 -A saw mill is being erected at Vernon, Ont., by W. J. Moses.
 -W. C. Edwards & Co. propose rebuilding the old saw mill at Vernon, Ont.
 -Prout's lumber mill at Oil Springs, Ont., recently destroyed by fire, is being rebuilt.
 -Mr. Kendrew, of Pond Mills, Ont., has rebuilt his saw mill which was recently burned.
 -R. H. and James Klock have commenced operations at Lindsay's saw mill, at Aylmer, Que.
 -The site of Mr. J. R. Booth's large mill at the Chaudiere, which was burnt a year ago, has been converted into a loading platform.
 -The Assiniboine Lumber Co., of Brandon, Man., commenced operating their mill early in July, their drive of logs having arrived.
 -For stealing lumber from T. A. Burrow's lumber yard at Winnipeg, Man., a resident was recently sentenced to fifteen days in the Provincial jail.
 -Owing to continued dry weather, Kelly Bros. and other mill owners in the vicinity of Amherst, N. S., have closed down their mills for want of logs.
 -The LeBlanc Manufacturing Co., of West Pubnico, N. B., are applying for incorporation, to manufacture doors, sashes, moulings, etc. The capital stock is placed at \$3,000.
 -R. McMaster, of Tremont, N. S., is overhauling the McMaster mills at that place, which consist of a saw mill, including shingle and stave machines, threshing and grist mills, etc.
 -James Hamilton & Sons, of Glen Huron, Ont., were heavy losers recently by floods, their lumber sheds and contents, with piles of lumber, wood and staves being washed down the river.
 -D. E. Sprague has secured the contract to supply the lumber required in the erection of the Northern Elevator Company's new elevator to be built at Winnipeg. The amount is over 500,000 feet.
 The Ontario Government will hold an examination of candidates for licenses as saw-log cutters at Huntsville, Ont., on Wednesday, the 7th of August. This will be the last examination held this season.
 The largest pile of sawdust in the world is said to be at Cheboygan, Mich., in the center of the city. It is nearly 800 feet long, about 600 in width, from 20 to 60 feet in height, and contains about 30,000,000 cubic feet.

-R. A. Mackenzie's timber limit in the Beaver Hills, Edmonton district, N. W. T., was burned recently by a bush fire.
 -The Union Furniture Co., of Wingham, Ont., are about to commence the erection of a new brick factory on the old site.
 -On 25th May last Mr. Malcolm McKinnon, of South Falls, Muskoka, cut 76,000 shingles in 10 3/4 hours (stoppages included). This astonishing cut was made in Mr. Geo. Kiety's mill on a Gravenhurst Boss machine with a saw made by the E. R. Burns Saw Co. of Toronto.
 Thos. Scott, of March, is reported to have commenced suit against the W. C. Edwards Company, of Ottawa, to recover \$15,000 damages for the death of his son, which he claims to have been due to lack of provisions in the camp. The charge is denied by the foreman of the camp.
 -Mr. Dery is putting up a new steam saw mill at St. Late, Que., while that of Messrs. Rosseau & Vallee, at Notre Dame des Anges, is nearing completion. The mill of H. Price is also well supplied with logs, and great activity is reported in saw mill business along the route of the Quebec and Lake St. John Railway.
 -McLachlin Bros., of Azarior, Ont., recently filled an order for twenty white pine saw logs for Messrs. Skillings, Whitney & Barnes, of Ogdensburg, which are to be shipped to New York and from thence consigned to the Sultan of Turkey. The logs are very fine ones, splendid samples of the products of our Canadian forests.
 -Prince Albert, Sask., has three saw mills. Of these the local paper says: Sanderson's saw mill in the west end, and Shannon's mill in the east end are running full time at present. The Moore & Macdowell Company are having trouble with their drive of logs, but expect to begin sawing operations at an early date. All these mills are preparing exhibits of Saskatchewan lumber for the Regina exhibition.
 -On May 29th the warping tug "Alligator," owned by the Hardy Lumber Co., Alpena, Mich., was wrecked while ascending the Persia rapids, on the French river. Angus McEachen, one of four men on board, was carried over the rapids and lost his life in the whirlpool below. The "Alligator" has been replaced by the "Victoria," both tugs being manufactured by Messrs. West & Peachy, of Simcoe, Ont.
 The Gillies Brothers Company, of Braeside, Ont., have commenced an action against the New York Central & Hudson River R. R. Company to recover \$1,133.08 damages for the loss of lumber, consisting of five car-loads which was destroyed by fire at Morristown, May 22, 1891. The plaintiffs allege that the fires were due to sparks from the R. W. & O. locomotives. The case will be placed on the calendar of the November circuit in Watertown.
 -The new machinery in Mr. Peters' large saw mill at Parry Sound, Ont., was put to work recently, and is reported as running satisfactorily. The mill has been completely remodelled,

and is now one of the finest on the Georgian Bay. It has two band saws built by the Waterous Manufacturing Co., and a fine gang saw from the William Hamilton Co., of Peterboro, besides the usual number of edgers, trimmers, lath mill, etc., as well as many new features. The mill and yards are also furnished throughout with electric light and will be run day and night.

CASUALTIES.

-Win. Newell, of Parry Sound, lost a finger of his right hand in Peters' saw mill a fortnight ago.
 -A youth named O'Leary was drowned while working on Gilmour's drive about 28 miles from Dorset, Ont.
 -Samuel Forman had the first and second fingers of his left hand taken off recently at Phillips' stave mill at Chatham, Ont.
 -Hugh Cameron, an employee of the Pembroke Lumber Co., was killed by lightning while working on a boom about a mile from Pembroke, Ont.
 -A young man named Archie Stewart, of Horton, Ont., was drowned at the foot of Palmer Rapids while engaged on a log drive for Mr. John Ferguson, M. P.
 -A young man named Grosseau, in the employ of W. C. Edwards, of Ottawa, was caught in the machinery of the saw mill and had his arm torn off in pieces. It is thought he cannot recover.
 -A sad accident occurred at Ross Bros.' mill at Buckingham, Que., on the 11th ultimo, by which Baptiste Lascelle lost his life. He was working at the edger when a board flew, striking him over the heart and causing almost instant death.
 -The 16-year old son of Denis Logan, of Carleton Place, Ont., had his foot caught in the endless chain which operates the sawdust carriage in a large saw mill at that place. The leg was drawn over the cog-wheel, terribly lacerating the foot and leg, which had to be amputated.
 -A workman named Henry Martin met a horrible death in William Hornburg's saw mill at Forestville, Ont., on the 5th of July. In taking a board off the ways it was caught on the saw, and threw him upon it. A great chunk was cut from his side, and the saw mangled the leg on one side and cut off the other near the ankle.
 -About two weeks ago, Judd Buckman, fireman in a large saw mill at Severn Bridge, Ont., had the misfortune to lose part of his thumb and forefinger of his left hand by coming in contact with a saw. A few years ago Mr. Buckman lost all the fingers of his right hand in a mill at Gravenhurst, and much sympathy is expressed for him.
 -By the bursting of a piston of the steam log roller in Wm. Peters' saw mill at Parry Harbor, Ont., on the 18th July, Charles Jefferson, a blacksmith, lost his life, while Joseph Bovaier, an engineer, and Alex. Adair and W. H. Dearborn were severely cut about the head and face. The accident occurred while heating the piston rod in the blacksmith's forge.

Lumbermen's Supplies

We are making a Specialty of Lumbermen's Supplies, and are offering, with other goods, a good Japan Tea, fine draw and make, at 12 1/2 cents. Get a sample of this splendid Tea suitable for the Camp.

H. P. Eckardt & Co.

WHOLESALE GROCERS - TORONTO.

CAMP SUPPLIES

Being extensive operators in the lumber business, as well as Wholesale Grocers, we are exceptionally well qualified to fill orders for Lumbermen's Supplies.

MAIL ORDERS GIVEN PROMPT ATTENTION.

DAVIDSON & HAY

Wholesale Grocers TORONTO

Every Lumberman wants it 35 cents buys it

Scribner's Lumber and Log Book

SAVES TIME SAVES MISTAKES SAVES MONEY

BRIMFUL OF EVERY-DAY, PRACTICAL INFORMATION Address: THE CANADA LUMBERMAN, Toronto

... STEARNS BROTHERS ...

Patent Rossing Machine

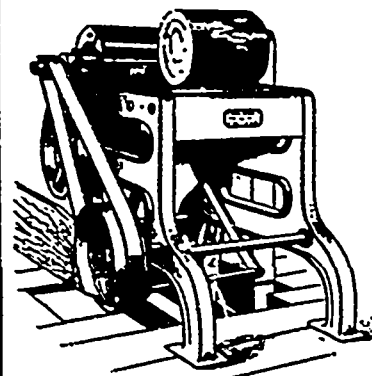

Why you should use this Rosser.
 It will do double the work of any other.
 It is the only machine made that will peel Cedar Shingle Blocks.
 It will peel dirty blocks without taking the edge off the knives as they cut from the clean bark or block out.
 It is a self-feeder, and very easy to operate.
 It requires less power than a face wheel.
 All iron and steel, very simple and durable.
 It will ross knotty and uneven timber without waste.
 It occupies about the same space as an ordinary planer.
 You can have a chance to try a machine before buying it.

... MANUFACTURED BY ...

EASTMAN LUMBER CO. EASTMAN, QUE.

ROSEWOOD FROM INDIA.

ROSEWOOD from South America still holds the British market. One writer says in a British journal that Indian rosewood ought to displace the South American. Among other things he says: The natives of India have long recognized the valuable qualities of the blackwood or rosewood of the southern district of our great dependency, and its utility for furniture has been demonstrated at various exhibitions in London during the last few years. It is largely employed for carving purposes, some of the most elaborate work being done in this rosewood. It is closely allied to the "sisso," and the tree grows to an immense size in the Annamally forest. Specimens are frequently found forty to fifty feet in girth, and it is found in other parts of India and Burmah. The wood is close-grained, strong, flexible, fibrous and durable, and generally of a deep purple color. This is sometimes mottled with greenish-black veins, which fade to a dark brown or black. When sawed, it emits an agreeable odor. Admitting a high polish, its use for the best class of furniture is apparent when considered with other qualities.

The logs, some of which, imported to London in 1878, sold for \$68 per ton, are sent from India from 9 to 16 feet long and from 20 to 34 inches in diameter, and are in a very sound condition. The wood does not warp when cut into boards, and when treated with oil, a common circumstance in India, it becomes almost black. These qualities have resulted in its employment by the Madras government for the construction of gun-carriages, for which purpose it has long been used in Bombay. Cabinet-makers hold it in high repute, and its suitability for the interior fittings of ship cabins, railway carriages and the like should lead to its early extended use in this country. The wood is said to be equal to Bahia or Rio rosewood, and taking into account its cheapness and superior widths, as well as its soundness, a great desideratum in converting, there can not be any doubt, at half the price of the other rosewoods, the wood from India must eventually supplant the ordinary kinds. Already our French neighbors, with their usual keenness to adopt new woods, are very large consumers, notwithstanding the national prejudice against wood supplied from the colonies of Great Britain.

A FEW STEAM PUMP CALCULATION*

WANTED—A steam pump to deliver 1,000 gallons per minute. Strokes per minute, 40; length of stroke, two feet; steam pressure, 80 pounds; head to pump against, 100 feet; allowance for loss, 20 per cent. A loss of 20 per cent. necessitates calculations for 1,000 gallons + 20 per cent., or 1,200 gallons per minute. This divided by 7.48 gives 160.4 cubic feet of water per minute. Dividing 160.4 by 40 we have 4.01 cubic feet per stroke, and call it 4, omitting the decimal. Dividing again by the length of the stroke (in feet) we get 4 ÷ 2 = 2 square feet as the area of the pump cylinder, or about 19½ inches for diameter; a pretty large diameter for the stroke, but necessary to meet the requirements, although it would be better to lengthen the stroke to three feet. The head of 100 feet (.434 pounds per foot, but calling it .5, makes an allowance for friction) gives us fifty pounds pressure per sq. inch of piston, and the piston area equals 2 + 144 = 288 square inches, 288 ÷ 50 = 14.400 pounds total pressure on the piston to be overcome by steam pressure on the steam piston. Dividing the total load by the steam pressure we have 14,400 ÷ 80 = 180 square inches for the steam piston plus 20 per cent. loss in the steam cylinder, etc.—15.25 + 3.05 = 18.3 inches as steam cylinder diameter. The conditions here given are a little unusual, the head being low for the pressure used, and the stroke short for the diameter; also the small number of strokes per minute, but the method of calculating is clearly shown and can be done for any selected case. In the case of suction or lifting pumps simply add the lift to the head forced against and use this as a total head, making an allowance for possible leaks in the suction pipe.

LUMBERING ON THE ST. MAURICE RIVER.

AN official of the Lake St. John, Que., railway says: "There are not a dozen people in Quebec or Montreal, who have any conception of the lumbering operations being carried on this year on the St. Maurice river. You will be astonished in fact, when I tell you that the volume of business is almost as extensive as on the Ottawa. One firm alone, and at one point, employ 1,100 men and 600 horses, and the supplies for this little army mostly come from the city of Montreal. Where our

bridge crosses the river a pulp mill has been erected at a cost of one million dollars. Both in the mill and in the woods the number of men employed must run up to very near a thousand. As a matter of fact, no one can form any estimate as to the magnitude of the several industries along the river St. Maurice without being on the spot."

The Ottawa Saw Manufacturing Company is putting in machinery for the manufacture of hand saws.

THOMAS PINK
 MANUFACTURER
 OF
 LUMBERING
 TOOLS

SKIDDING TONGS
 CANT HOOK
 GAFF
 SOCKET
 CANT HOOK CLASP

PEMBROKE, ONT.
 OTTAWA ENG CO

ROBIN, SADLER & HAWORTH

MANUFACTURERS OF

OAK TANNED LEATHER BELTING

MONTREAL AND TORONTO

Pumps
 & HYDRAULIC
 MACHINERY

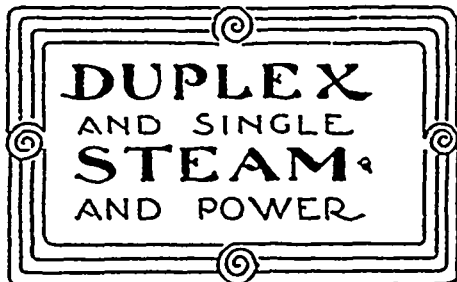

THE NORTHEY MFG. CO., Ltd.
 TORONTO

THE LAURIE ENGINE CO. - MONTREAL
 SOLE AGENTS FOR PROVINCE OF QUEBEC.

J. V. MAITLAND—H. RIXON

J. G. AINSIE—W. STODAR

MAITLAND, RIXON & CO.

OWEN SOUND, ONT.

Saw Millers and Lumber Dealers

All kinds of Building Material kept in stock

WE MAKE A ... SPECIALTY OF **LONG BILL STUFF IN ROCK ELM, PINE, CEDAR AND HEMLOCK**
Quotations furnished on application

GALT MACHINE KNIFE WORKS



MACHINE KNIVES
OF EVERY DESCRIPTION FOR
Planing, Moulding and Stave Cutting
—Send for Price List—

PETER HAY, GALT, ONT.

THE DOMINION LEATHER BOARD COMPANY

— MONTREAL —
MANUFACTURERS OF

Friction Pulley Board

.. AND ..

ROOFING, SHEATHING AND FLOORING FELTS

Please mention the CANADA LUMBERMAN when corresponding with Advertisers.

THE ROYAL ELECTRIC COMPANY

MONTREAL, QUE.

Western Office: TORONTO, ONT.

Cable and Telegraph Address, "Roylelectric."

MANUFACTURERS OF

Electrical Machinery and Apparatus

... FOR ...

LIGHT and POWER

SPECIAL ATTENTION GIVEN TO

LONG DISTANCE TRANSMISSION OF ELECTRICITY
FOR LIGHT AND POWER

ALSO FOR

ELECTRIC PLANTS FOR MILLS

Distant water powers utilized and Mills lighted and operated safely.
CORRESPONDENCE SOLICITED.

WHY BAND SAWS BREAK

SIXTEEN

REASONS,

AND HOW TO

AVOID THEM



Being instructions to filers on the care of large band saw blades used in the manufacture of lumber.

A book filled with valuable information on the care of band saws. Giving the reasons for breaking; analyzing each reason; giving instructions to dispense with the causes as laid down in each reason; and full details on filing and brazing. The proper styles of hammers to use are illustrated and described, and views of blades showing the blows of the different styles of hammers form an important part of the illustrations. Improper and unequal tension are then treated, and the manner of properly setting irregular teeth is described. In connection with the treatise is a history of the invention, manufacture and use of the saw from its origin to the present time. The work in whole makes an accumulation of information such as has never before been published.

The book is printed on fine paper, good clear type, and is handsomely and substantially bound in cloth. It will be sent to any address on receipt of the price, **ONE DOLLAR.**

Address— CANADA LUMBERMAN, Toronto, Ont.

SHURLY & DIETRICH

— GALT, ONT. —

MANUFACTURERS OF

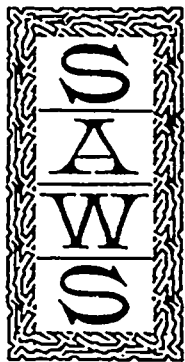

THE ONLY SAW MANUFACTURERS IN THE WORLD WHO EXPORT SAWS IN LARGE QUANTITIES TO THE UNITED STATES

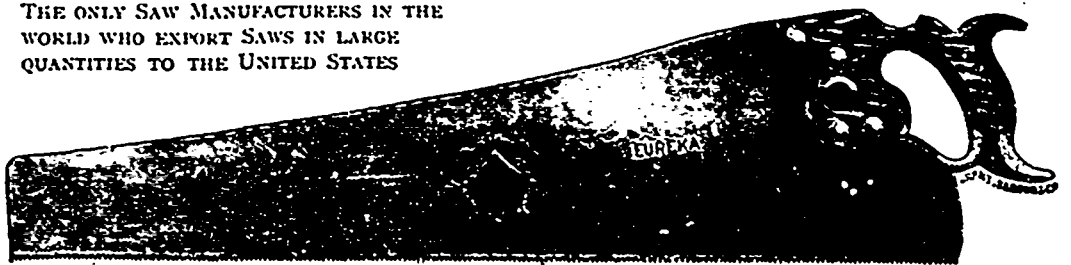

SOLE PROPRIETORS OF THE SECRET CHEMICAL PROCESS OF TEMPERING: : Our Silver Steel Saws are Unequaled

OAK TANNED BELTING

TORONTO
20 FRONT ST EAST
TELEPHONE 475

THE J.C.M^cLAREN BELTING CO MONTREAL

Haines & Company LUMBER DEALERS

ESTABLISHED 1861.
Office and Yards, foot of Erie St. Buffalo, N. Y.
Within 7 minutes' walk of principal hotels and depots.

CALCUTT'S Boiler Improvement

Any person using a Steam Boiler can save 50 per cent. of their fuel and get 50 per cent. more power out of their boiler by having

CALCUTT'S WATER-TUBE IMPROVEMENT

attached. The expense is only a trifle compared to the saving derived. Send for Circular, Box 55, Peterborough, Ont.

Peterborough Steam
Boiler Company

ARE YOU LOOKING FOR A CHANGE IN LOCATION?

If you are not satisfied with your present site, or if you are not doing quite as well as you would like to, why not consider the advantages of a location on the Illinois Central R. R. or the Vandalia & Mississippi Valley R. R. ? These roads run through South Dakota, Minnesota, Iowa, Wisconsin, Illinois, Indiana, Kentucky, Tennessee, Mississippi and Louisiana, and possess

FINE SITES FOR NEW MILLS
BEST OF FREIGHT FACILITIES

CLOSE PROXIMITY TO

COAL FIELDS AND DISTRIBUTING CENTERS

AND

INTELLIGENT HELP OF ALL KINDS
MANY KINDS OF RAW MATERIAL

For full information write to the undersigned for a copy of the pamphlet entitled

100 Cities and Towns **WANTING INDUSTRIES**

This will give you the population, city and county debt, death rate, assessed valuation of property, tax rate, annual shipments, raw materials, industries desired, etc.

To sound industries, which will bear investigation, substantial inducements will be given by many of the places on the lines of the Illinois Central R. R. which is the only road under one management running through from the North-Western States to the Gulf of Mexico. GEO. C. POWER Industrial Commissioner I.C.R.R. Co., 505 Central Station, Chicago.

RAILS FOR TRAMWAYS

NEW AND SECOND-HAND STEEL AND iron rails for tramways and logging lines, from 12 lbs. per yard and upwards; estimates given for complete outfit.

JOHN J. GARTSHORE,
49 Front St. West, Toronto.

LUMBER TRUCK WHEELS

The Montreal Car Wheel Co.

... MANUFACTURERS OF ...

Charcoal Iron Gilted

RAILROAD WHEELS

OFFICES:

NEW YORK LIFE INSURANCE BUILDING, MONTREAL

WORKS: LACHINE, QUEBEC

We make a specialty of Wheels suitable for the requirements of Lumbermen and Street Car Service, and can supply them Hored, Finished and Balanced.

CORRESPONDENCE
SOLICITED

THE PARMENGER

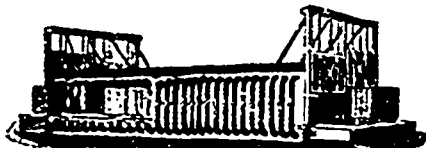

PATENT DRY KILN.

The Latest, the Cheapest and Best

FOR DRYING

LUMBER, STAVES, HEADING, ETC.

Write for Particulars to

J. S. PARMENTER,

Box 512, Woodstock, Ont.

MCEACHREN'S IMPROVED SYSTEM OF KILN DRYING. PATENTED.



COST of erecting, running and maintaining the lowest and results the highest of any dry kiln and drying system in the market. Green Elm, Ash, Whitewood, &c., for furniture dried in six days; only exhaust steam 10 hours per day used.

NO CHECKING, WARPING OR CASE-HARDENING.

THE MCEACHREN HEATING & VENTILATING CO. Galt, Ont.

THE CHATHAM GIANT LOG TRUCK

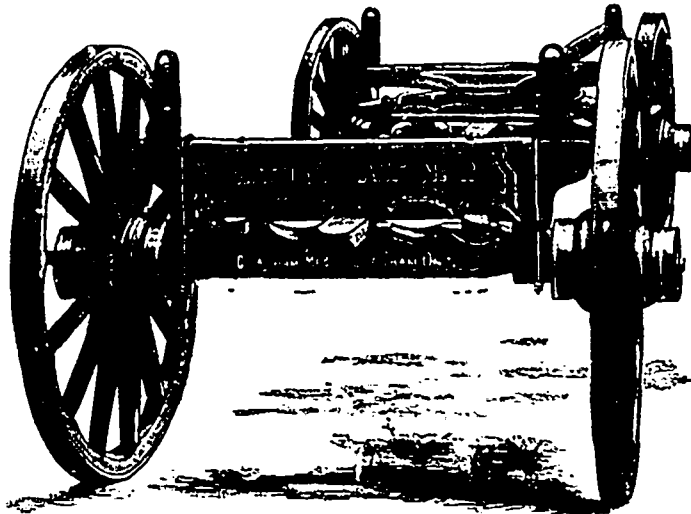

It must be self-evident that our GIANT ARM LOG TRUCKS, of which the above is a faithful illustration, is the best log truck made; but if conclusive evidence of this is wanted we refer to every mill man and lumberman in the county of Essex, Ont., where millions upon millions of Elm logs are gotten out every year on them, and where these trucks sell readily, while those of other makes remain unsold at \$5 to \$10 less.

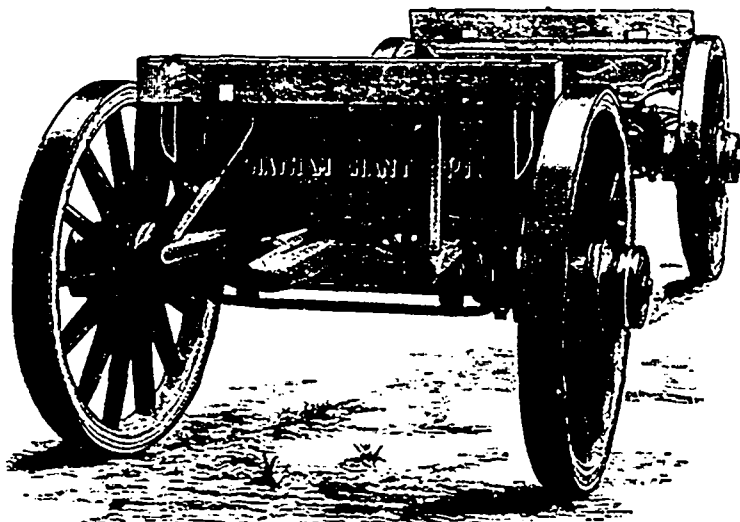

THE CHATHAM GIANT LOG AND LUMBER TRUCK

As seen above it is a Lumber Truck, but it is quickly converted into a Log Truck by bunks which are grooved at the ends to receive the stakes and slip down between them, and are perforated for side or lug poles. We build these trucks in all sizes from 2 1/2 to 4 inch Malleable Giant Arms. Farmers all over are extensively adopting the lighter sizes as general purpose wagons.

In reference to above trucks we would call the attention of the reader to the accompanying illustration of VANALLEN'S PATENT GIANT ARM with which they are equipped.

It will be seen that the hind bolster and sand-board are formed to rest upon the flat top of this arm, and being securely clipped to the axles forms a complete and solid truss and render the axles unbreakable and inflexible.

Our Malleable Giant Arm farm and teaming Wagons have no equals on this continent, of which the judges on vehicles at the World's Fair, Chicago, gave us an unqualified certificate in the shape of a GOLD MEDAL AND DIPLOMA.

CORRESPONDENCE SOLICITED

The Chatham Mfg. Co., Ltd.
CHATHAM, ONT.

LUMBERMEN AND MILL MEN!

WHO WANT
THE BEST

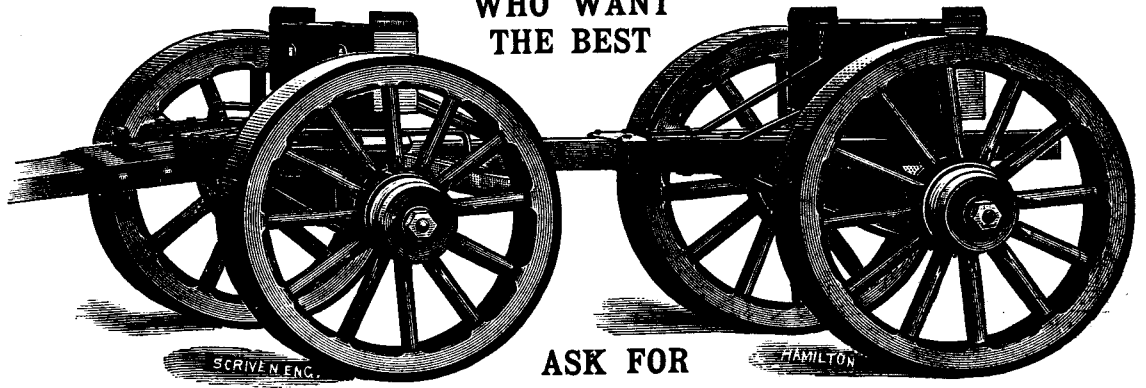

ASK FOR

Bain's Heavy Log Trucks

Furnished with Steel or Cast Skeins, 3 1/4, 4, or 4 1/2 arms. Any width tire. Are well built of thoroughly seasoned timber, heavily ironed and well finished. Built of any capacity required. Are **STRONG, DURABLE, and LIGHT** running. A trial order will be most convincing. Satisfaction guaranteed. Write us for further information. Address all orders or inquiries to

BAIN BROS. MFG. CO., Brantford, Ont.

BEST MAIN DRIVE. REGISTERED TRADE MARK. GUARANTEED.

Sole Canadian Agents: WATERLOO, BRANTFORD, CANADA. Prices Reduced.

THE CANADIAN PHOTO ENGRAVING BUREAU

TELEPHONE 2156

170 ADELAIDE ST. W. TORONTO

COPPER-WOOD ENGRAVINGS

FOR ALL KINDS OF ILLUSTRATIONS

GELIAS & BRO

ALL KINDS TIMBER & LUMBER

POUGH DRESSEL

BUFFALO, N.Y.

... THE ...

FLINT & PERE MARQUETTE RAILROAD

FROM Port Huron and Detroit

Is the Short Line to SAGINAW AND BAY CITY

(Centres of the vast lumber interests of Michigan)

MT. PLEASANT, CLARE, REED CITY
BALDWIN, LUDINGTON, MANISTEE
AND MILWAUKEE, WIS.

The last-named place reached by the Company's line of steamships across Lake Michigan.

The line thus formed is a short and direct route from

MONTREAL TORONTO

and all Canadian Territory

To ST. PAUL, DULUTH and Pacific Coast Points.

This road traverses a section of Michigan with unrivalled advantages to settlers. Cheap lands, thriving villages and towns, well watered with streams in all directions: a market for every product of Forest and Field.

The policy of the "F. & P. M." is known to all travellers and settlers.

A. PATRIARCHE, Traffic Manager.

GENERAL OFFICES: SAGINAW, MICH.

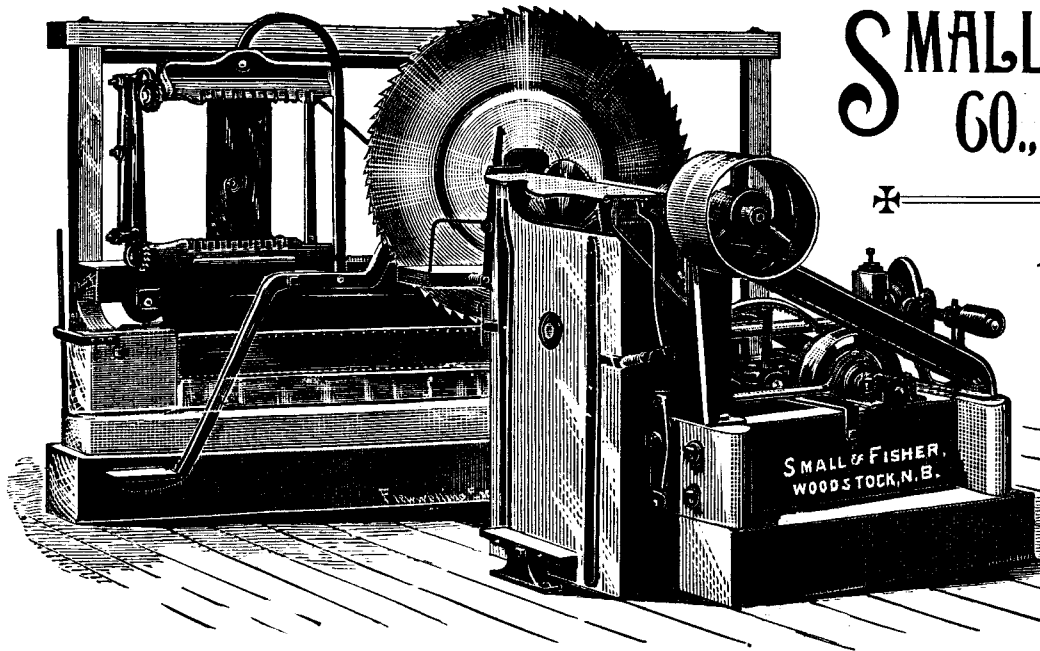

SMALL & FISHER CO., Ltd.

Woodstock, N. B.

Patent Shingle Machine

P. PAYETTE'S . . .

PATENT FRICTIONAL FEED DOUBLE EDGER

In four sizes

WITH FULL IMPROVEMENTS

MANUFACTURERS OF Saw Mill Machinery

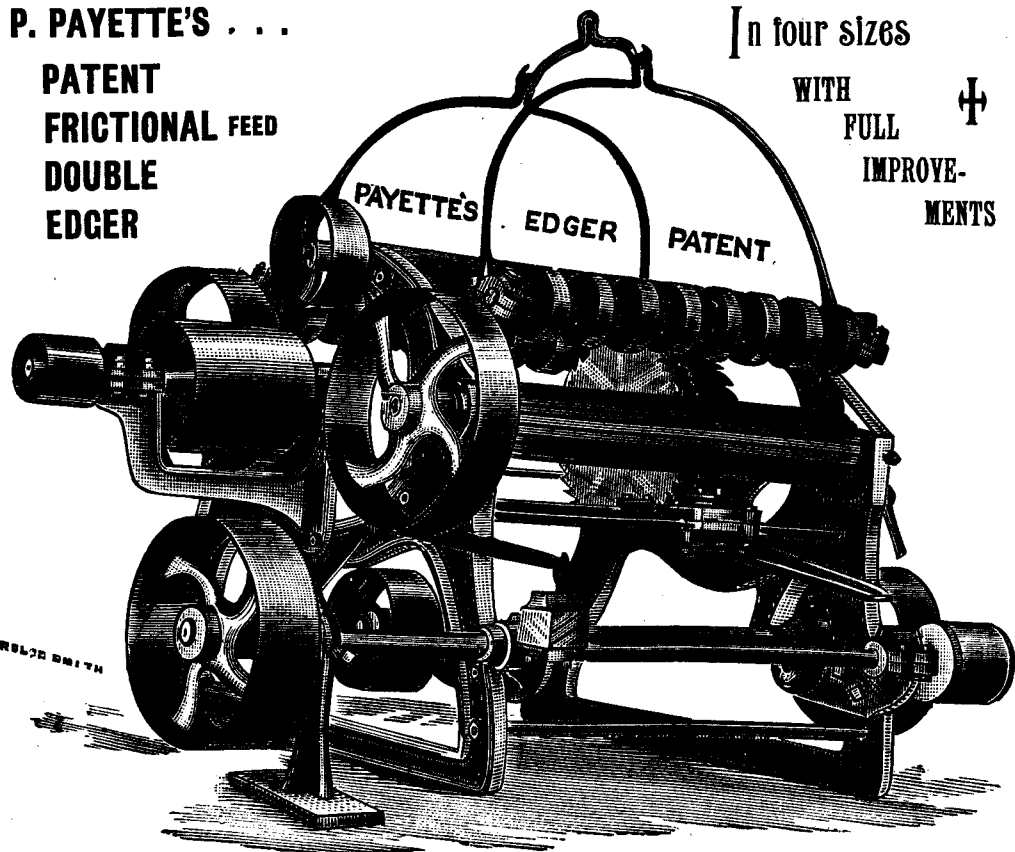

- Circular Saw Rigs, Light and Heavy Wood or Iron Frames.
- Rope and Chain Feed for Saw Carriages.
- Live Rollers, Wood or Iron.
- Log Canners, Light and Heavy.
- Double Edgers, Friction and Direct Feed.
- Head Blocks, Light and Heavy.
- Mill Dogs, Saw Guides.
- Trimmer, Log and Carrier Chains.
- Set Works, Top Saws.
- Brass and Iron Fittings.
- Saw Swage for Circular, Gang or Band.
- Swing Saws, Trimmers.
- Butting Tables.
- Boilers and Boiler Fittings.
- Shafting, Boxing, Pulleys, Hangers.
- Paper Frictions, Wood and Iron.
- Brass and Iron Castings of all kinds.
- Machinery for Lath Mill.
- " Shingle Mill.
- " Gang Mill.
- " Re-sawing.
- " Jack-Ladder.
- " Drag Saw.
- " Engines, Stationary and Marine.
- " Pumps.
- " Making Matches.
- Cant Hook Handles.

Terms and Prices on application.
P. Payette & Co.
Penetanguishene, Ont.

Dodge Patent Specialties

Dodge Wood Split Belt Pulleys
 Dodge Split Friction Clutch and Cut-off Coupling
 Dodge System of Rope Transmission of Power
 Dodge Rope Dressing for preserving Transmission Ropes

1895 CATALOGUE MAILED ON APPLICATION.

DODGE WOOD SPLIT PULLEY CO.

OFFICE, 68 KING ST. WEST
TORONTO

Canada Atlantic Railway

OTTAWA, ARNPRIOR AND PARRY SOUND RAILWAY

— OPERATING THE —

Ottawa and New York Lumber Line - Ottawa and Boston Lumber Line - Canada Atlantic Fast Freight Line

(Operating over the Grand Trunk, Central Vermont, and Boston and Maine Railways.)

—: SHORTEST AND QUICKEST ROUTE :—

... FROM AND TO ...

OTTAWA	ARNPRIOR	HAWKESBURY
TORONTO	MONTREAL	BURLINGTON
BUFFALO	QUEBEC	BOSTON
DETROIT	HALIFAX	NEW YORK
TONAWANDA	PORTLAND	ALBANY, &C.

AND ALL POINTS IN CANADA AND THE UNITED STATES.



R. A. CARTER
Contracting Agent, 115 Board Trade
MONTREAL

JOHN SMITH
Ontario Agent, Board Trade
TORONTO

CAPT. J. H. WILLIAMS
15 Lumber District, Albany, N. Y.

G. J. SMITH
General Freight Agent, Ottawa

P. S.—The opening of the Ottawa, Arnprior and Parry Sound Railway, Ottawa to the Georgian Bay, offers to the manufacturer and purchaser a new district not heretofore reached by any other line.

Dauntless Shingle and Heading Machine

∴ **WILL** make more Shingles per day than any self-acting machine with vertical saw in existence, and more Shingles from the same quantity of timber.

THE FRAME

... Is of Iron throughout, very heavy and rigid, strongly bolted and braced.

THE CARRIAGE

... Is very light and strong, made of forged Cast Steel Plate, running on steel ways or tracks. Will take in a block 18 inches wide and 19 inches long, adjustable for 16-inch or 18-inch shingles.

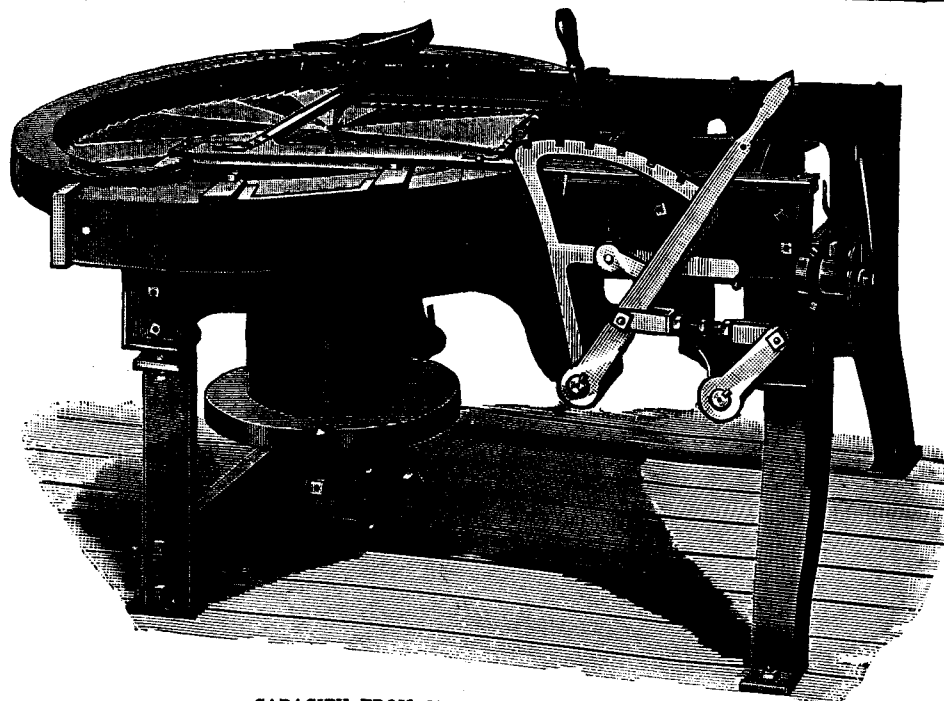

—CAPACITY FROM 25,000 TO 50,000 PER DAY—

[COPY.]

HASTINGS, Dec. 3, 1894.
F. J. DRAKE, Esq., Belleville.

Dear Sir,—We have waited two years before giving you our idea of your machinery. This we did to thoroughly test it, and can now say we know what it can do.

Your Saw Mill is equal, or nearly equal, to any we have seen of much heavier make, and far in advance of any light rig in the market. The capacity per day is fully up to your guarantee, 40 M per day. We have tested with eight men.

The Shingle Mill cannot be beaten for any kind of timber. Ours being in a manner a custom mill, we have good, bad and indifferent timber, but for all it does the work satisfactorily.

You may use this in any way you please, or refer to us at any time.

Yours truly,
(Sgd.) W. J. & H. W. FOWLDS.

(F. J. DRAKE)

PATENTEE AND ... MANUFACTURER OF SAW, SHINGLE AND LATH MACHINERY
BELLEVILLE, ONT.