

**CIHM
Microfiche
Series
(Monographs)**

**ICMH
Collection de
microfiches
(monographies)**



Canadian Institute for Historical Microreproductions / Institut canadien de microreproductions historiques

© 1995

Technical and Bibliographic Notes / Notes technique et bibliographiques

The Institute has attempted to obtain the best original copy available for filming. Features of this copy which may be bibliographically unique, which may alter any of the images in the reproduction, or which may significantly change the usual method of filming are checked below.

- Coloured covers / Couverture de couleur
- Covers damaged / Couverture endommagée
- Covers restored and/or laminated / Couverture restaurée et/ou pelliculée
- Cover title missing / Le titre de couverture manque
- Coloured maps / Cartes géographiques en couleur
- Coloured ink (i.e. other than blue or black) / Encre de couleur (i.e. autre que bleue ou noire)
- Coloured plates and/or illustrations / Planches et/ou illustrations en couleur
- Bound with other material / Relié avec d'autres documents
- Only edition available / Seule édition disponible
- Tight binding may cause shadows or distortion along interior margin / Le reliure serrée peut causer de l'ombre ou de la distorsion le long de la marge intérieure.
- Blank leaves added during restorations may appear within the text. Whenever possible, these have been omitted from filming / Il se peut que certaines pages blanches ajoutées lors d'une restauration apparaissent dans le texte, mais, lorsque cela était possible, ces pages n'ont pas été filmées.
- Additional comments / Commentaires supplémentaires:

L'Institut a microfilmé le meilleur exemplaire qu'il lui a été possible de se procurer. Les détails de cet exemplaire qui sont peut-être uniques du point de vue bibliographique, qui peuvent modifier une image reproduite, ou qui peuvent exiger une modifications dans la méthode normale de filmage sont indiqués ci-dessous.

- Coloured pages / Pages de couleur
- Pages damaged / Pages endommagées
- Pages restored and/or laminated / Pages restaurées et/ou pelliculées
- Pages discoloured, stained or foxed / Pages décolorées, tachetées ou piquées
- Pages detached / Pages détachées
- Showthrough / Transparence
- Quality of print varies / Qualité inégale de l'impression
- Includes supplementary material / Comprend du matériel supplémentaire
- Pages wholly or partially obscured by errete slips, tissues, etc., have been retilmed to ensure the best possible image / Les pages totalement ou partiellement obscurcies par un feullet d'errate, une pelure, etc., ont été filmées à nouveau de façon à obtenir le meilleure image possible.
- Opposing pages with varying colouretton or discolourations ere filmed twice to ensure the best possible image / Les pages s'opposant ayant des coloretions variables ou des décolorations sont filmées deux fois afin d'obtenir la meilleur image possible.

This item is filmed at the reduction ratio checked below /
Ce document est filmé au taux de réduction indiqué ci-dessous.

	10X		14X		18X		22X		26X		30X
	12X		16X		20X		24X		28X		32X

The copy filmed here has been reproduced thanks to the generosity of:

National Library of Canada

The images appearing here are the best quality possible considering the condition and legibility of the original copy and in keeping with the filming contract specifications.

Original copies in printed paper covers are filmed beginning with the front cover and ending on the last page with a printed or illustrated impression, or the back cover when appropriate. All other original copies are filmed beginning on the first page with a printed or illustrated impression, and ending on the last page with a printed or illustrated impression.

The last recorded frame on each microfiche sheet contains the symbol \rightarrow (meaning "CONTINUED"), or the symbol ∇ (meaning "END"), whichever applies.

Maps, plates, charts, etc., may be filmed at different reduction ratios. Those too large to be entirely included in one exposure are filmed beginning in the upper left hand corner, left to right and top to bottom, as many frames as required. The following diagrams illustrate the method:

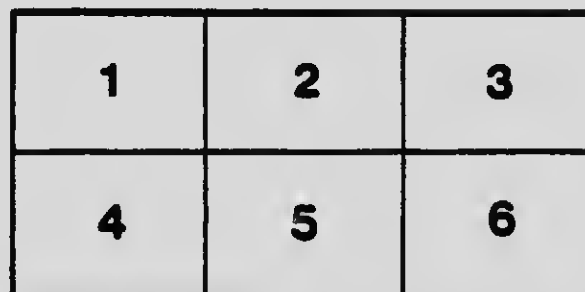
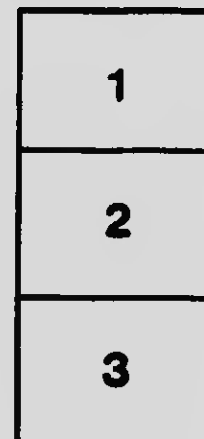
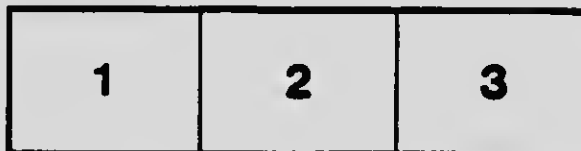

L'exemplaire filmé fut reproduit grâce à la générosité de:

Bibliothèque nationale du Canada

Les images suivantes ont été reproduites avec le plus grand soin, compte tenu de la condition et de la netteté de l'exemplaire filmé, et en conformité avec les conditions du contrat de filmage.

Les exemplaires originaux dont la couverture en papier est imprimée sont filmés en commençant par le premier plat et en terminant soit par la dernière page qui comporte une empreinte d'impression ou d'illustration, soit par le second plat, selon le cas. Tous les autres exemplaires originaux sont filmés en commençant par la première page qui comporte une empreinte d'impression ou d'illustration et en terminant par la dernière page qui comporte une telle empreinte.

Un des symboles suivants apparaît sur la dernière image de chaque microfiche, selon le cas: le symbole \rightarrow signifie "A SUIVRE", le symbole ∇ signifie "FIN".

Les cartes, planches, tableaux, etc., peuvent être filmés à des taux de réduction différents. Lorsque le document est trop grand pour être reproduit en un seul cliché, il est filmé à partir de l'angle supérieur gauche, de gauche à droite, et de haut en bas, en prenant le nombre d'images nécessaire. Les diagrammes suivants illustrent la méthode.

MICROCOPY RESOLUTION TEST CHART

(ANSI and ISO TEST CHART No. 2)

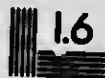
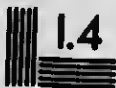
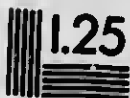

APPLIED IMAGE Inc

1653 East Main Street
Rochester, New York
(716) 482 - 0300 - Ph
(716) 288 - 5989 - Fax

USA

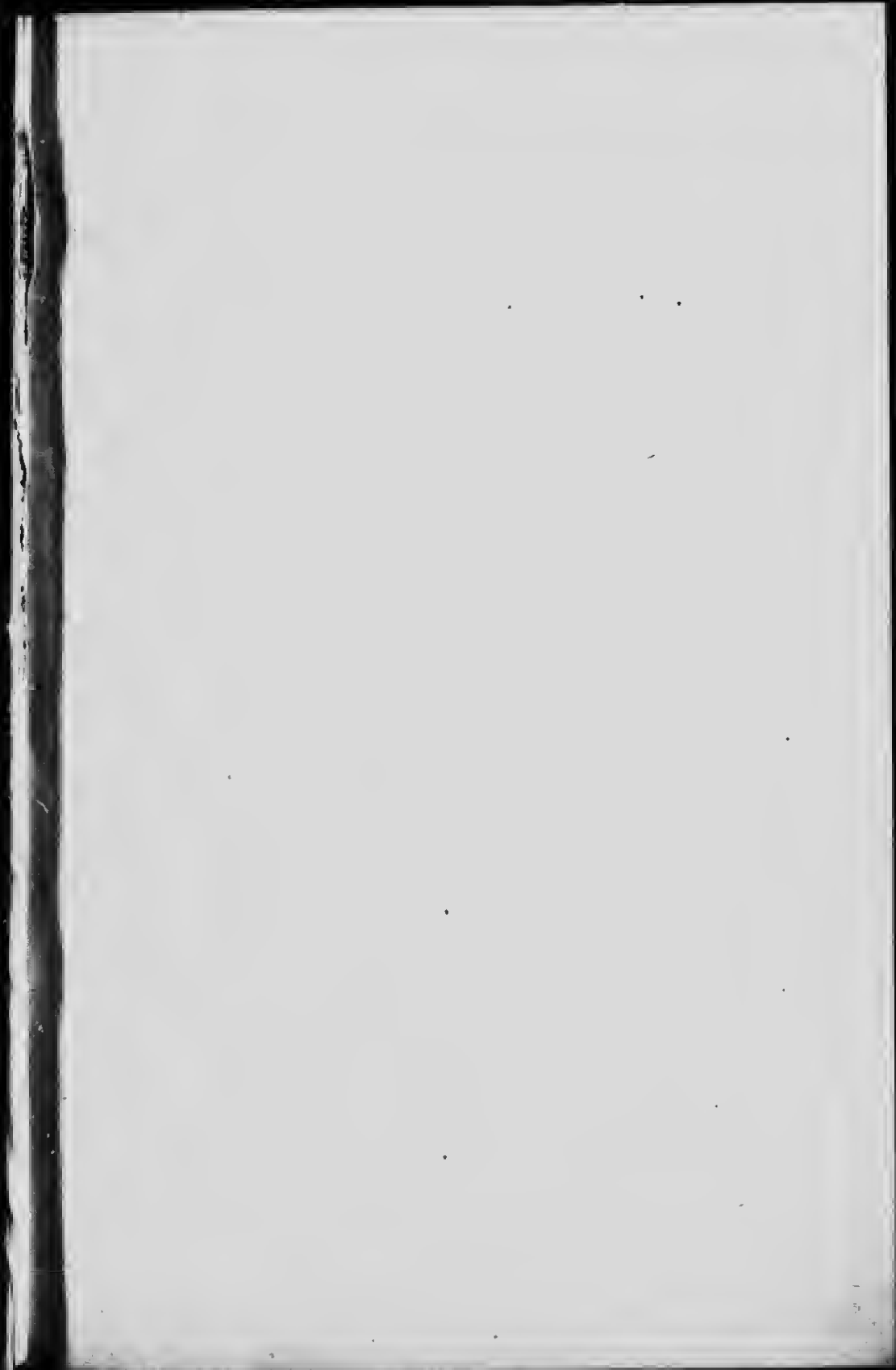

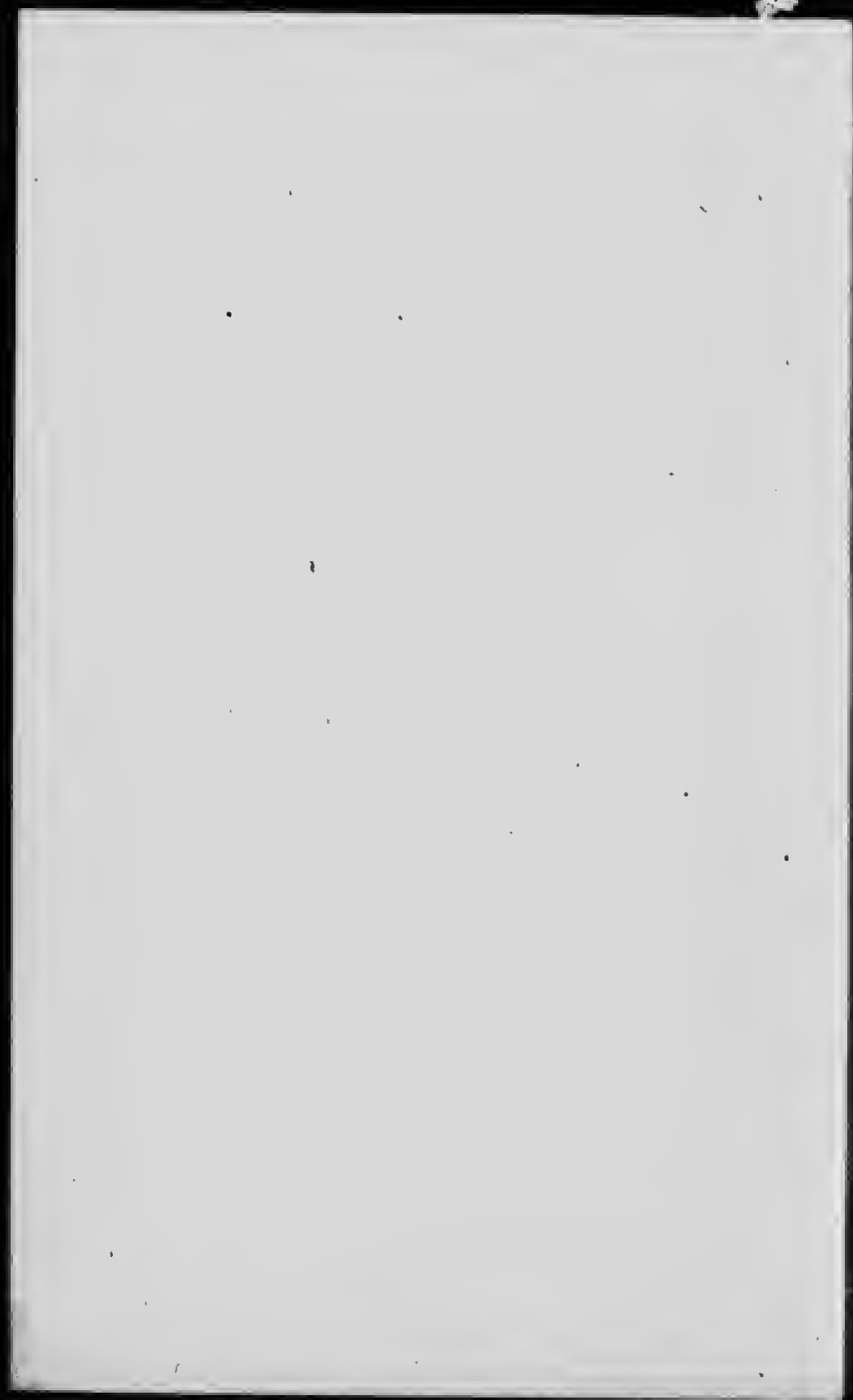

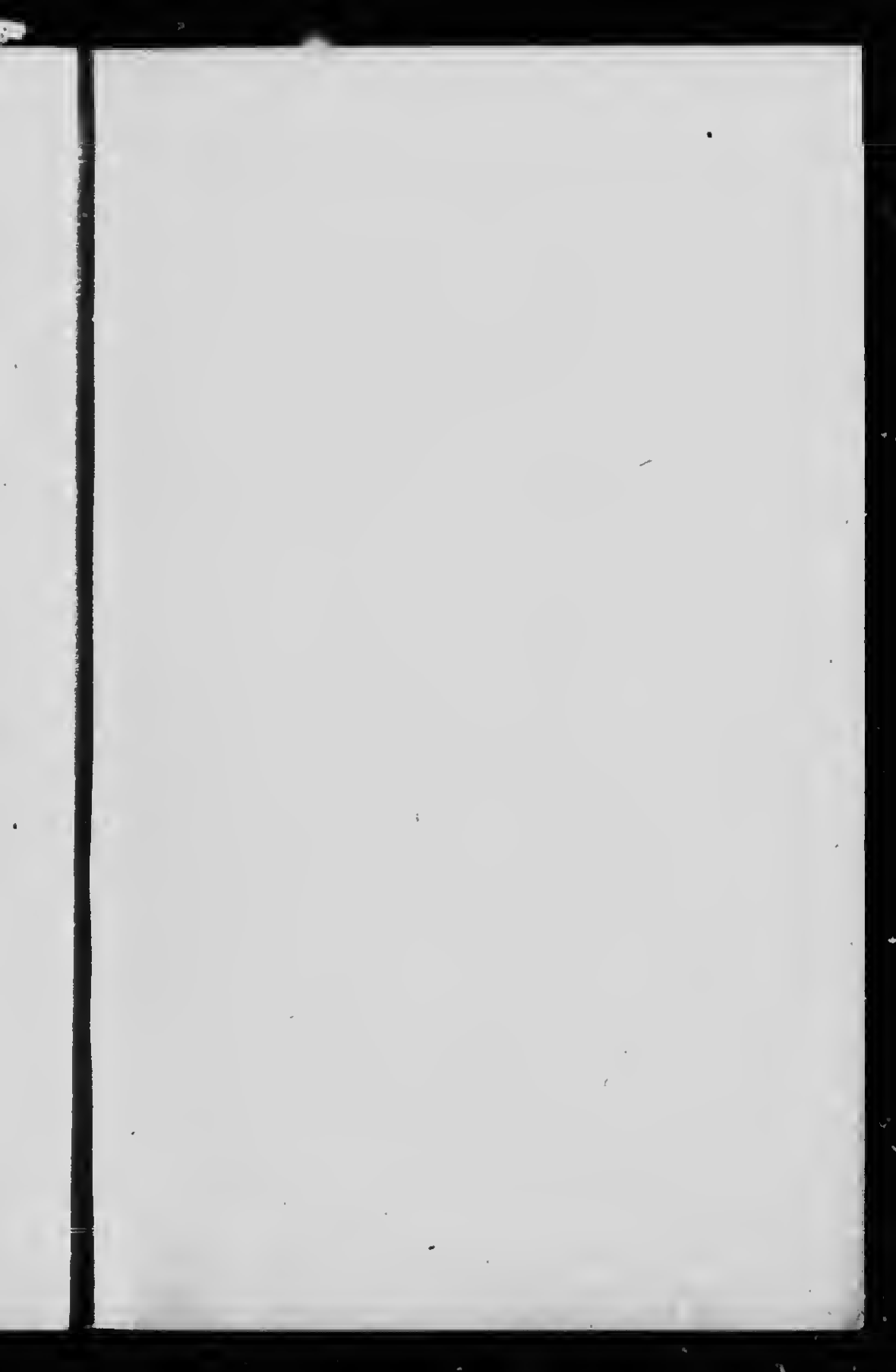



A Household Management pupil in uniform

ONTARIO
TEACHERS' MANUALS

HOUSEHOLD MANAGEMENT



AUTHORIZED BY THE MINISTER OF EDUCATION

TORONTO
THE COPP, CLARK COMPANY, LIMITED

TX167

H6

COPYRIGHT, CANADA, 1916, BY
THE MINISTER OF EDUCATION FOR ONTARIO

CONTENTS

	PAGE
COURSE OF STUDY—DETAILS	1
CHAPTER I	
Introduction	5
Correlation with Other School Subjects	7
Rooms	9
Equipment	12
Tables, seats, racks, sinks, class cupboard, stoves, black-boards, illustrative material, book-case, utensils	23
Equipment for Twenty-four Pupils	23
Class table, sink and walls, general cupboard equipment, kitchen linen, cleaning cupboard, laundry equipment, dining-room equipment, miscellaneous	28
Equipment for Ordinary Class-rooms	28
Equipment, Packing-box	30
For Class	31
Individual Equipment for Six Pupils	32
CHAPTER II	
Suggestions for Class Management	33
Teachers' Preparation	33
Number in Class	33
Uniforms, etc.	33
Discipline	34
Division of Periods	35
Assignment of Work	36
Supplies	37
Practice Work at Home	37
Suggestions, General	38
Suggestions for Schools with Limited or no Equipment	39
CHAPTER III. FORM III: JUNIOR GRADE	
Correlations	42
Arithmetic, geography, nature study, hygiene, physical training, composition, spelling, manual training, art, sewing	45
CHAPTER IV. FORM III: SENIOR GRADE	
Scope of Household Management	46
Equipment, Uniform, etc., Survey of	47
Equipment, Use of	48

CHAPTER IV. FORM III: SENIOR GRADE—Continued	PAGE
Cleaning, Development of a Lesson on	
Meaning of Cleaning	49
Methods of Cleaning	49
Common Household Cleansing Agents	50
Black-board Outline	51
Dish Washing	52
Table Cleaning	53
Sink Cleaning	54
Dusting	54
Measures and Recipes	
Measures	55
Equivalent Measures and Weights, Table of	58
Measuring, Plan of Lesson on	58
Time limit, preparation, development, practical work to apply measuring, serving, note-taking, housekeeping, recipe for cocoa	62
Recipes	62
 CHAPTER V. FORM III: SENIOR GRADE (Continued)	
Cookery	
Meaning of Cooking	64
Reasons for Cooking Food	64
Kinds of Heat Used	64
Different Ways of Applying Dry Heat	64
Different Ways of Applying Moist Heat	64
Thermometer, Lesson on	65
Boiling Carrots, Plan of Lesson on	68
Aim, time limit, preparation for practical work; practical work; development of the ideas of boiling as a method of cooking; serving, housekeeping, recipe in detail....	70
Simmering Apples, Plan of Lesson on	70
Introduction, discussion of recipe, practical work, development of ideas of simmering; serving, housekeeping, recipe (individual)	72
Methods of Cooking: Details	73
Boiling	73
Simmering	74
Steaming	74
Steeping	75
Toasting	76
Broiling	76
Pan-broiling	77
Sautéing	78
Baking	78
Frying	79

CONTENTS

vii

CHAPTER V. FOAM III: SENIOR GRADE— <i>Continued</i>	PAGE
Left-overs, Suggestions for the Use of	82
Bread, cake, meat, fish, eggs, cheese, vegetables, canned fruit	84
Beverages	84
Meaning of Beverages	84
Kinds of Beverages	85
Tea, coffee, cocoa, chocolate	86
Table Setting	87
Table Manners	90
CHAPTER VI. FORM IV: JUNIOR GRADE	
Kitchen Fire, The	92
Requirements	93
Heat, oxygen, fuels	96
Kitchen Stove, The	96
Fireless Cooker, The	99
Principles of Fireless Cooker	100
Reasons for Use of Fireless Cooker	100
Ways of Using Fireless Cooker	100
Home-made Fireless Cooker, A	101
CHAPTER VII. FOAM IV: JUNIOR GRADE (Continued)	
Food, Study of	103
Uses of Food	103
Necessary Substances in Food	105
Sources of Food	106
Common Foods, Study of	106
Milk	107
Eggs	110
Vegetable Food, Study of	114
Comparative food value of different parts of plants	119
Green vegetables, root vegetables and tubers, ripe seeds (peas, beans, and lentils)	120
Vegetables, General Rules for Cooking	122
Fruit, General Rules for Cooking	123
Fresh Fruit	123
Dried Fruit	123
Starch, Use of, to Thicken Liquids	124
Flour, Use of, to Thicken Liquids	125
Cream of Vegetable Soups	126
Principles of Cream Soups	126
Seeds, Outline of Lesson on Cooking	127
Cereals	127
Legumes: Peas, Beans, Lentils	128
Nuts	128

CHAPTER VII. FOAM IV: JUNIOR GRADE—Continued		PAGE
Salads		129
Ingredients of Salads		129
Food Value of Salads		129
Preparation of Ingredients		130
Dressings for Salads		130
Mineral Food, Study of		131
Summary of Sources of Mineral Foods		133
Diet		133
Reference Table of Food Constituents		134
Water, mineral matter, protein, sugar, starch, fat		134
Preparing and Serving Meals: Rules		135
CHAPTER VIII. FOAM IV: JUNIOR GRADE (Continued)		
House, Care of the		138
Bed-room, Directions for Cars of		138
Sweeping, Directions for		139
Dusting, Directions for		140
Metals, Care and Cleaning of		140
Iron or steel, tin, granite and enamel ware, aluminum, zinc, galvanized iron, copper or brass, silver, recipe for silver polish		144
CHAPTER IX. FOAM IV: JUNIOR GRADE (Continued)		
Laundry Work		145
White Cotton and Linen Cloths, Lesson on Washing		145
Materials—water, alkalies, soap, soap sub- stitutes or adjuncts, bleaching, starch		149
Preparation for Washing		150
Process of Washing		151
Removal of Stains		152
Woolens, Outline of Lessons on Washing		153
Experiments with Cloth Made of Wood Fibre		154
Points in Washing Woolens		155
Steps in Washing Woolens		155
CHAPTER X. FOAM IV: SENIOR GRADE		
Foods		157
Food, Preservation of		158
Bacteria		158
Canning		160
Jams and Preserves		163
Jelly		164
Pickling		165

CONTENTS

ix

	CHAPTER XI. FOAM IV: SENIOR GRADE (Continued)	PAGE
129	Cookery	166
129	Flour, Outline of Lesson on	166
129	Sources of flour, kinds of flour made from	
130	wheat, composition of white flour, kinds of	
130	wheat flour, tests for bread flour	167
131	Flour Mixtures, Outline of Series of Lessons on ..	168
183	Meaning of flour mixtures, kinds of flour	
133	mixtures, methods of mixing flour mix-	
134	tures, framework of flour mixtures, light-	
136	ening agents used in flour mixtures	169
	Experiments	170
	Baking-powder	170
	Cake making	171
	Classes of cake, directions for making cake,	
	rules for mixing cake, directions for baking	
38	cake	173
38	Recipe for Basic Cake	174
39	Variations of Recipe for Basic Cake	174
40	Spice cake, nut cake, fruit cake, chocolate	
40	cake	174
	Recipe for Basic Biscuits	175
44	Variations of Recipe for Basic Biscuits	175
	Sweet biscuit, fruit biscuit, scones, fruit	
	scones, short cake for fruit, dumplings for	
	stew, steamed fruit pudding	175
45	Bread Making	176
	Yeast, Outline of Lessons on	177
45	Bread Making, Practical	179
	Ingredients of plain bread, amount of in-	
49	redients for one small loaf, process in	
50	making bread	180
51	Breads, Fancy	180
52	Bread-mixer, The	182
53	Pastry	183
54	Pastry, outline of lesson on—ingredients...	184
56	Notes on flour, fat, water; lightening	
56	agents used in pastry; kinds of pastry;	
	amount of ingredients for plain pastry	
	for one pie	184
7	 CHAPTER XII. FOAM IV: SENIOR GRADE (Continued)	
8	Meat	186
0	Name of Meat	187
3	Parts of Meat	188
4	Composition of Fat	188
5	Composition of Bone	188
	Composition of Muscle	190

CHAPTER XII. FOAM IV: SENIOR GRADE—Continued		PAGE
Meat Experiments		191
Selection of Meat		192
Care of Meat		193
General Ways of Preparing Meat		193
Notes on Tough Meat		193
Digestibility of Meat		195
General Rules for Cooking Meat		198
Baking, broiling, boiling, stewing, beef juice.		199
Fish		
Points of Difference Between Fish and Ordinary Meat		199
Kinds of Fish		200
Selection of Fish		200
Cooking of Fish		200
Gelatine		200
Source		201
Commercial Forms		201
Properties		201
Steps in Dissolving		201
Value in Diet		202
Ways of Using		202
Frozen Dishes		203
Vaine		203
Kinds		203
Water ice, frappé, sherbet, ice cream, plain ice cream, mousse		203
Practical Work		204
Freezing, packing, moulding		204
Planning of Meals		205
CHAPTER XIII. FORM IV: SENIOR GRADE (Continued)		
Infant Feeding		208
Modified Milk, Recipe for		209
Pasteurizing Milk, Directions for		209
Bottles, Care of		210
Food, Care of		210
Feeding, Schedule for		211
CHAPTER XIV. FOAM IV: SENIOR GRADE (Continued)		
Household Sanitation		212
Means of Bacteria Entering the Body		212
Common Disease-producing Bacteria		213
Methods of Sanitation		214
Disposal of Waste in Villages and Rural Districts		215
Methods of Disinfecting		215

CONTENTS

xi

CHAPTER XIV. FORM IV: SENIOR GRADE—Continued

	PAGE
Home Nursing	216
Sick Room, The	216
Location, furniture, ventilation, care	216
Disinfecting, Methods of	218
Patient, The	218
Care of the bed, and diet	218
Poultices	221
Fomentations	222

BIBLIOGRAPHY

Home, The	223
Science and Sanitation	223
Food and Dietetics	223
Cooking and Serving	224
Laundry Work	224
Home Nursing	225
Economice	225
Magazinee	225

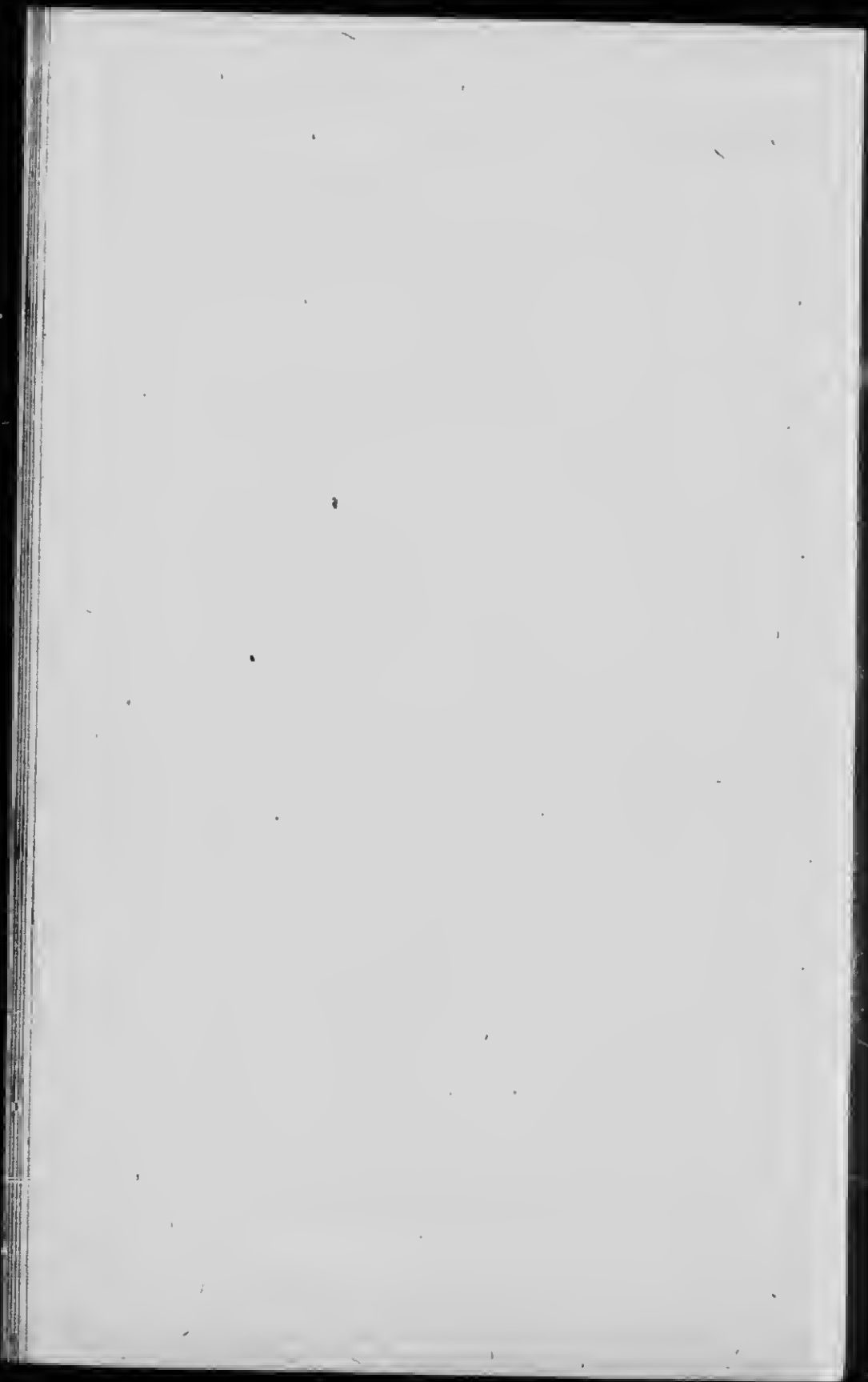

**PUBLIC AND SEPARATE SCHOOL
COURSE OF STUDY**

DETAILS

FORM III: JUNIOR GRADE

BILLS OF HOUSEHOLD SUPPLIES:

Furniture, bed and table linen, material for clothing
Fuel, meat, milk, groceries
Weekly or monthly expenses of an average household
Comparison of home and store cost of cooked food,
such as cake, bread, meat, canned fruit.

SOURCES OF HOUSEHOLD MATERIALS:

Fuel
Timber for building, and furniture
Cotton, linen, woollen, paper, china
Common groceries, such as salt, sugar, spices, tea,
coffee, cocoa, cheese, butter, cereals
Cleansing agents, such as coal-oil, gasolene, turpen-
tine, whiting, bathbrick, soap.

MANUFACTURE OF HOUSEHOLD MATERIALS:

Cotton, linen, woollens, paper
Salt, sugar, tea, coffee, cocoa, cheese, butter, cereals.

KITCHEN AND EQUIPMENT:

Arrangement of a convenient kitchen
Necessary utensils.

HOUSEHOLD MANAGEMENT

FORM III: SENIOR GRADE

CLEANING:

- Elementary principles of cleaning
- Practice in cleaning dishes, tables, sinks, towels.

COOKERY:

- Table of cooking measurements
- A recipe (parts, steps in following)
- Reasons for cooking food; kinds of heat used; methods of cooking
- Practice in making simple dishes of one main ingredient.

SERVING:

- Setting the table
- Table service and manners.

FORM IV: JUNIOR GRADE

THE KITCHEN FIRE:

- Requirements of a fire
- Comparative merits of fuels
- Construction and care of a practical stove.

STUDY OF FOODS:

- Uses of food to the body
- Necessary elements in food
- Composition of the common foods, excepting meat and fish.

COOKERY:

- Practice lessons in preparing and cooking the common foods, (milk, eggs, meat, fish, fruit, vegetables)
- Cooking and serving a simple breakfast and a luncheon.

CARE OF THE HOUSE:

- Review of methods of cleaning taken in Form III
- Cleaning and care of household metals
- Sweeping and dusting
- Care of a bed-room.

LAUNDRY WORK:

- Necessary materials and the action of each
- Process in washing white clothes.

NOTE.—These subjects are intended to be taught simply (not technically). In schools where there is no laundry equipment, the order of work may be developed in class and the practice carried on at home.

FORM IV: SENIOR GRADE

PRESERVATION OF FOOD:

- Causes of decay, principles and methods of preservation
- Practice in canning.

COOKERY:

- Practice lessons to review cooking common foods
- Flour (kinds, composition of white flour); flour mixtures (kinds, methods of mixing, lightening agents)
- Practice in making bread and cake
- Practice in cooking meat
- Cooking and serving a simple home dinner at a fixed cost.

FOODS:

- Composition of meat and fish
- Planning meals so as to obtain a broad balance of food elements.

INFANT FEEDING:

- Proper food; pasteurizing milk
- Care of bottles and food
- Schedule for feeding.

HOUSEHOLD SANITATION:

- Disposal of waste
- Principles and methods of sterilizing and disinfecting.

HOME NURSING:

Two simple lessons to include the following:

1. The sick-room (location, size, ventilation, care)
2. Care of patient's bed, and diet
3. Making of mustard and other simple poultices.

NOTE.—Where no equipment has been provided, a large doll and doll's bed will serve.

LAUNDRY WORK:

Washing of woollens (the processes).

HOUSEHOLD MANAGEMENT

CHAPTER I

INTRODUCTION

UNTIL a comparatively recent period, education was regarded mainly as a means of training the intellect, but this conception of education is now considered incomplete and inadequate. Our ideas of the purpose of schools are becoming broader, and we have decided that not only the mental nature, but all the child's activities and interests, should be given direction by means of the training given in our schools. We believe also that these activities and interests can be used to advantage in assisting the mental development.

Household Management aims to educate in this way, by directing the mind to ideas connected with the home and by training the muscles to perform household duties.

Though deemed essentially practical, this subject will, if rightly presented, give a mental training similar to other subjects of the Course of Study. It should do more. While a pupil is made familiar with the duties of home life and with the materials and appliances used in the home, she will be unavoidably led to think of the work of the larger world and to realize her relation to it. When such knowledge comes, and a girl begins to feel that some part of the world's work depends on her, true character-building will begin.

The purpose of this Manual is to assist teachers in presenting Household Management to public and separate school classes in such a way as to attain these ends. It is hoped that it will be especially useful to those teachers whose training in the subject has been limited.

An attempt has been made to explain the work of Form III Senior, and of the Junior and Senior divisions of Form IV. The topics of Form II Junior are not discussed, as the work of this Form is intended to be taught as information lessons, for which general methods will suffice. In the other Forms mentioned, the topics of lessons are outlined in detail, but the method of presentation is not given except in typical cases. Both outline and method are intended to be merely suggestive and to leave opportunity for the teacher's originality.

In cases where topics seem incompletely outlined, it is due to the fact that they are treated in other school subjects or postponed until the pupils reach a more advanced stage of mental development.

The order of lessons is optional, also the amount of work each should include, unless this is specially stated.

Many lessons are suitable for rural schools, which have no equipment except what the ingenuity of the teacher may provide. In such schools, the teacher may perform the practical work, while the class observes.

Throughout the lessons, there is the difficulty of presenting scientific facts to immature minds in a way that will be simple and clear. The use of technical language would often assist the expression, and this is apt to be unconsciously employed, but there is danger of such forms of speech not being intelligible to the pupils; the teacher

should therefore choose her words carefully. Technical terms may be taught, but this is not advised in Junior classes, unless really necessary. If the facts are intelligently related to the experiences of the pupils, that is all that is desired.

Temperatures, as indicated by Fahrenheit thermometers, have always been given, as this scale is best known in the home.

Since this Manual is designed for teachers, few recipes have been furnished. The books of reference which are appended will supply these and additional information on the subject.

CORRELATION WITH OTHER SCHOOL SUBJECTS

One of the benefits of placing Household Management in a Course of Study is that it relates the knowledge gained in school to the home life.

The Household Management teacher has great opportunity for this correlation. She should be more than a teacher of household duties. She should lead the pupils to see the importance and necessity of mastering the other school subjects. Wherever interest in these subjects has already been established, this interest will form a basis for development in many Household Management lessons.

Then, too, the teachers of other subjects should, as far as possible, work with the Household Management teacher in relating their instruction to the operations and requirements in the home. If the teachers co-operate in planning their lessons, the pupils will receive a deeper impression of the facts learned in each subject and will have an increased interest in the work, through seeing how one branch of knowledge is related to another.

The following will show how some of the subjects are related to the class work of Household Management:

Arithmetic.—This subject is used in household accounts, in measurements, in the division of recipes, and in computing the cost of foods prepared for the table.

Reading.—The pupils should be asked to read aloud the recipes and their notes and should be required to do this distinctly and accurately.

Spelling, Writing, Language Work.—In writing recipes and notes, in stories of household topics, and in written answers, the teacher should insist on neat writing, correct spelling, and good English.

Geography.—The study of materials for food, clothing, and house furnishings brings before the mind our commercial relations with foreign countries and the occupations of their inhabitants. It also suggests consideration of climate and soils.

History.—The evolution of furniture and utensils, of methods of housekeeping, and of preparing and serving food, brings out historical facts.

Elementary Science.—Throughout the Course, this subject is the foundation of much of the instruction given, as it explains the principles underlying household industries. Soap-making, bread-making, preservation of food, and the processes of cooking and cleaning are examples of this.

Some knowledge of elementary science is also necessary to an understanding of the construction and practical working of the kitchen stove, the fireless cooker, the cream separator, and many household appliances. Its principles determine the methods of heating, lighting, and ventilating.

Physiology and Hygiene.—The study of food and the planning and preparation of meals should include a knowledge of the body and its requirements. The sanitary

care of the house and its premises is directly related to hygiene.

Nature Study.—Animals and plants furnish us with most of our food, and familiarity with these is necessary to the housekeeper. A knowledge of the structure of animals is essential in studying the cuts of meat; the structure of plants and the functions of their different parts give a key to the value of vegetable food.

Physical Training.—The class should be carefully trained throughout in correct muscular movements. The position of the body should be closely watched in working and in sitting, and the classes should enter and leave the room in systematic order.

Manual Training.—The practical part of housekeeping demands constant use of the hands. The teacher should be watchful of awkward handling of materials and utensils and be careful to correct it. She should require deft, natural movements until they become habits.

Art.—Ideas of colour and design should be applied in choosing wall-papers, carpets, dishes, furniture, and clothing. The pupils might be asked to make original coloured designs for these household articles.

ROOMS

It is most desirable to have Household Management include all home operations and, to make this possible, more than one room should be provided. Many school boards, however, in introducing the work, find that one room is all that can be afforded. Where this is the case, it is necessary that this room be equipped as a kitchen, though it must be used for other purposes as well. It will serve also for table-setting and serving, for simple laundry work, for lessons in home-nursing, and for sewing.



A Household Management class at work

This kitchen should be large and airy, so that the class can work comfortably and conveniently. A room having greater length than width admits of the best arrangement.

On account of the odours that arise from cooking and other domestic operations, the kitchen should be on the top floor and should have more adequate means of ventilation than ordinary class-rooms. A north exposure makes it cooler in summer.



Opposite end of Household Management class-room, showing the black-board and class cupboard

EQUIPMENT

In planning an equipment, one must be guided by the conditions to be met. It is difficult to be definite in details, but certain general principles should be observed.

The entire equipment should be suited to the needs of the pupils, and it should also be one which it is desirable and possible for them to have in their own homes.



A Household Management class-room, showing tables, sinks, and stoves

The walls and floor should be washable, and they, as well as the furniture, should have plain, smooth surfaces which do not catch dust and are easily cleaned.

The sinks, stoves, tables, and cupboards should be placed so as to save steps.

TABLES

Where economy is necessary, movable tables may be used, but the fixed ones are to be preferred. The latter



Section of a table designed for two pupils

may be placed in the form of a hollow square or an oval, with openings from opposite sides to give convenient access to a centre table, which can be used for supplies or as a dining table.

Drawers and cupboards to hold the necessary utensils and supplies should be provided in the tables for each pupil. Provision may also be made under the table top

for desk boards, which may be pulled out when notes are written, in order to allow the pupils to sit comfortably in front of the cupboards. The table top should be of hard wood or some non-absorbent material, jointed in narrow strips in order to prevent warping. Part of this must be protected by a metal or glass strip on which to set the individual stoves or hot dishes.



Contents of a table cupboard equipped for two pupils

A working drawing and design of the tables used in the Normal Schools may be obtained from the Department of Education, Toronto.

SEATS

The seats may be swing seats, stools, or chairs. The swing seats are noiseless and easily put out of the way, but are uncomfortable and unsteady, so that the pupils are inclined to prop themselves by placing their elbows on the table. The stools and chairs are noisy and occupy a great

EQUIPMENT: DRAWERS

15

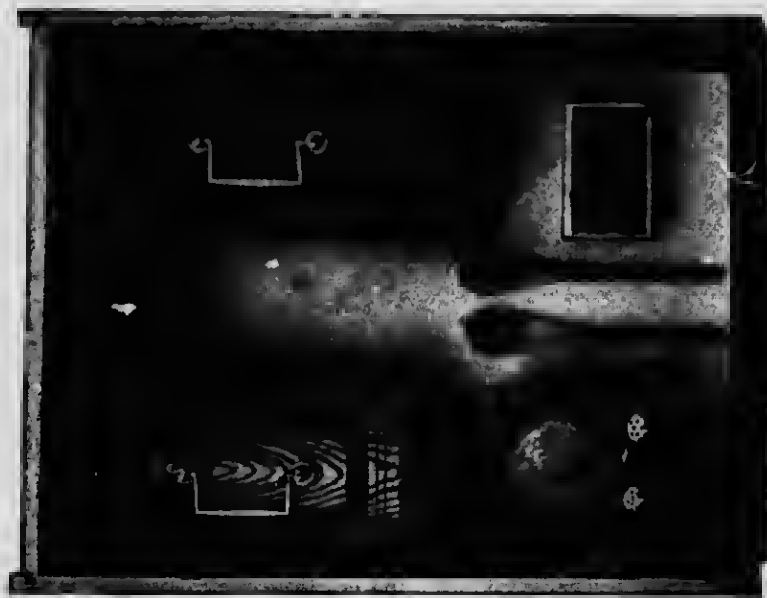

Contents of an individual supply drawer



Contents of an individual utensil drawer

deal of room, but the latter are restful and conducive to the correct position of the pupils, the importance of which cannot be over-estimated. The former are inexpensive, if made with a plain, wooden top. Both should admit of being pushed under the table, and for this reason the chairs should have folding backs. The legs should be tipped with rubber in order to minimize the noise.



A class towel rack

RACKS

Towel racks should be placed near the sinks and, if possible, should allow space for hanging the towels without folding. In some tables a towel rack may be attached to one of the sides.

SINKS

A sink at each corner of the room saves much time and inconveniences in the work. Each of these should be provided with hot and cold water. They may be made of porcelain or of enameled iron.



A class gas range, showing high ovens

CLASS CUPBOARD

A large class cupboard in two sections, having glass doors in the upper part to show the class china and glass, should be placed where it will be most convenient and add to the attractiveness of the room. This cupboard will hold the dinner set and extra dishes and utensils, as well as the linen and some staple food supplies. A refrigerator is desirable for such foods as butter, eggs, meat, etc.



A class cupboard

STOVES

The stoves provided will depend on the fuel that is available in the neighbourhood. Wood is still in use in some rural sections, while coal is the ordinary fuel in small towns and villages. Where either of these fuels is commonly used, there should be two ranges. One should

Individual table stoves



(a) a gas stove

(b) an electric stove



(c) a blue-flame kerosene stove (d) an ordinary kerosene stove

be for coal or wood, to teach the use of the home fuel, and the other an oil, gas, or electric stove, to demonstrate the time and labour saved the housekeeper by the use of one of these. If possible, the stoves should have high ovens, to obviate the necessity of stooping. A section of glass in

the oven door is a great convenience, as it allows the contents of the oven to be easily watched.

For individual work small table stoves are required. These may be supplied with oil, alcohol, gas, or electricity, as may be most readily obtained. These stoves may be arranged so that they can be swung from the table when not in use. In this way more room is provided for work, and the table is more easily cleaned. The tops of the stoves should be wide and flat, so that cooking dishes will not easily upset.

A fireless cooker, though not really necessary, is most helpful. Where funds are lacking, one may be made by the pupils at small expense. A barrel, wooden box, or large pail may be filled with hay or excelsior, and small, covered, granite pails may be used to contain the food.

BLACK-BOARDS

The black-boards should be of slate or glass, and as large as the size of the room allows. The windows and doors should be so placed that there will be unbroken stretches of wall for this purpose. Part of the black-board should be provided with a sliding board which, when required, can be drawn to conceal what is written. A separate black-board for current prices of common food materials is an excellent idea. The responsibility of keeping these prices correct should be given to the pupils.

ILLUSTRATIVE MATERIAL

A cabinet, or display case, for illustrative material, is of great educational value and, to the pupils, is one of the most attractive features of the room. The following list of specimens is suggestive for this:

1. Standard china, such as Crown Derby, Wedgwood, Limoges, Dresden, Boleek. etc.
2. Standard carpet, such as Axminster, Wilton, Brussels, Tapestry
3. Woods used for furniture and building



A display cabinet—canned fruit

4. Food materials in various stages of preparation, such as sugar, spices, cereals, tea, coffee, cocoa
5. Fruit canned by the pupils
6. Designs for wall-paper, linoleum, dishes, etc., made by the pupils.

3 H.M.

Other illustrative material in the form of charts showing the comparative values of the common foods, or illustrating cuts of meat or different kinds of vegetables and fish, will be found to aid greatly in making the teaching effective. There are few of these to be obtained, but home-made ones may be prepared from cuts in bulletins and magazines. Pictures illustrating the production and manufacture of food may also be mounted and used.

BOOK-CASE

Book shelves should be provided, where a small library of books bearing on the various phases of the subject may be kept, together with the Government Bulletins and some well-chosen periodicals and magazines. These may be selected from the *Catalogue of Books* which has been prepared by the Department of Education.

UTENSILS

In regard to the selection of small articles required, such as dishes and utensils of various kinds, the greatest care should be exercised. This part of the equipment can be exactly duplicated by the pupils in their homes, and in this way may be of educational value to the community. The cooking and serving dishes should combine quality, utility, and beauty.

It is not economy to buy cheap utensils. As far as possible, they should be chosen with smooth, curved surfaces, as seams and angles allow lodging places for food and make the cleaning difficult.

Everything should be of good quality, the latest of its kind that has been approved, and, at the same time, have a shape and colour that is artistic.

It is wise to buy from stock which can be duplicated if breakages occur, so that the equipment may be kept uniform. For individual work the utensils should not be too large.

Coloured granite ware is best for most of the cooking dishes. Where tin is necessary, it should be of a good quality. Crockery is desirable for some bowls, jars, and serving dishes. Spoons and serving forks should be of Nevada silver, and knives of the best steel with well-made wooden handles.

The cost of this part of the equipment and the number of articles purchased must of course depend on the funds available. The following list is intended to give what is really desirable in a specially equipped room, at prices which are a fair average.

**EQUIPMENT
FOR TWENTY-FOUR PUPILS**

I. CLASS TABLE

1. UTENSIL DRAWER:

24 plates, enamel, 9 inch	\$0.70
14 " white crockery, 7 inch80
24 bowls white crockery, 7 inch	3.60
24 " " " 5½ inch	1.20
24 enamel bowls, 6 inch	2.40
24 popover cups	1.80
24 bakera, crockery (oval)	1.20
24 platters, " (small)	1.50
24 sieves (wire bowl)	1.80
24 spoons, wooden	1.92
24 spatulas, wire handle	7.20
24 knives, paring	2.00
24 forks, Nevada silver	2.50

HOUSEHOLD MANAGEMENT

24 spoons, table, Nevada silver	\$2.50
48 spoons, tea, " "	1.20
24 cups, measuring, tin	2.40

2. SUPPLY DRAWER:

12 boxes (for flour), tin	10.00
12 " (for sugar), "	7.50
12 cheese jars (for salt)68
24 bakery, glass	2.40
24 bread tins	4.32
24 biscuit cutters72
13 safety match-box holders	1.62

3. SUPPLY CUPBOARD:

12 double boilers	5.76
24 stew pans, tin cover, wooden knob	4.56
24 frying-pans	1.20
24 saucepans	2.16
12 knife-boards	1.80
12 meat boards	3.00
6 scrub basins	1.50
12 dish pans	6.00
12 rinsing pans	3.00
12 draining pans	3.00
6 tea-kettles	3.00
12 scrub-brushes	2.00
12 vegetable brushes30
12 soap dishes75
12 garbage crocks96
24 asbestos mats	1.10

II. SINK AND WALLS

1 garbage pail, galvanized iron	1.00
1 waste-paper basket, willow (large)75
1 soap dish11
1 brush, hand03
1 brush, scrub17
2 basins, hand, enamel40

EQUIPMENT

25

2 basins, scrub, enamel50
1 dieb pan70
1 crock for wasbing soda30
2 towel racke	1.50
1 clock	5.50
12 tablete for housekeeping rulee70

III. GENERAL CUPBOARD EQUIPMENT

2 kettlee, granite	1.50
1 tea-kettle, granite85
1 eaucepan28
1 eaucepan35
5 covere, tin25
1 pie pan10
1 coffee-pot32
6 eaucepane, 1 qt. size, white enamel	1.08
1 double boiler59
6 covere, tin30
1 soup ladle, enamel09
2 pudding disbee, white enamel40
12 etrainere and maebere	1.80
1 kneading pan85
3 eteamere67
10 gratee	1.00
2 vegetable baskete30
6 potato maebere48
4 muffin pans60
24 patty-pane20
12 Dover egg beatere	1.20
1 spice box50
1 japanned tray25
24 wire toasters	2.40
1 egg epade15
1 ecale	3.10
1 freezer	3.00
1 cast-iron frying-pan40
1 dripping pan25
2 roasting pans60

HOUSEHOLD MANAGEMENT

1 quart measure, granite60
1 pint measure, "45
1 funnel, tin05
4 baking sheets 7" x 17"92
6 " " 10" x 10"	1.08
24 cups and saucers	1.30
24 tumblers	1.50
6 platters36
6 plates34
6 pitchers, 1½ pt.	1.00
3 brown bowls, 2 qt.75
2 brown bowls25
nest of mixing bowls	1.00
6 glass measuring cups60
6 glass lemon reamers60
6 tea-pots (pint)	1.50
1 covered crock25
1 doz. 1 qt. fruit jars65
1 " 2 qt. " "75
1 " 1 pt. " "55
1 meat chopper	3.10
1 bread knife25
1 bread board25
2 knives, French85
2 spoons, granite21
1 fork, large wooden handle15
2 can openers20
1 corkscrew25
1 bunch skewers15
1 brush, pastry05
1 knife sharpener25
3 graters, nutmeg09
1 box toothpicks05
1 pad tissue paper05
3 scissors	1.25
1 doz. jelly glasses35
1 cream and sugar30

EQUIPMENT

27

.60	24 rolling-pins	3.00
.45	1 butter spade15
.05	1 file and catch65
.92	3 doz. test-tubes90
1.08	1 " thermometers (Dairy)	2.50
1.30	2 lamp chimneys30
1.50	1 bell40

.36

.34

1.00

.75

.25

.00

.60

.60

.50

.25

.65

.75

.55

.10

.25

.25

.85

.21

.15

.20

.25

.15

.05

.25

.09

.05

.05

.25

.35

.30

IV. KITCHEN LINEN

36 yards	towelling (3 doz. dish towels).....	5.40
16 "	" " (4 doz. wash cloths)	2.40
13 "	check towelling (3 doz. dish cloths)...	1.60
6 "	towelling75
6 "	" (6 meat cloths)60
1½ "	flannelette (oven cloths)23
12 "	cheesecloth60
1½ "	denim (stove apron)27
2 "	flannelette (for polishing silver)20
	chamois25

V. CLEANING CUPBOARD

1	stove apron27
1	stove brush25
1	dauber10
3	whisk brooms45
1	dust-pan20
1	pair stove mitts30
1	broom45

VI. LAUNDRY EQUIPMENT

14	pony washboards	1.75
6	doz. clothes-pins10
1	clothes-line25

HOUSEHOLD MANAGEMENT

VII. DINING-ROOM EQUIPMENT

1. China and Glass:

1 flower vase25
1 dinner set, Limoges china	15.50
1 doz. water glasses80
1 glass fruit set	1.50

2. Silver and Steel:

2 doz. teaspoons	4.20
1 " dessert spoons	4.00
1 " tablespoons	1.15
1 " dessert knives	4.50
1 " dessert forks	4.50
1 " dinner knives	4.50
1 " dinner forks	4.50
1 carving set	2.00
1 butter pick20

3. Linen, etc.:

1 silence cloth	1.50
1 4 yd. table-cloth	5.40
1 doz. napkins	2.75
1 centre-piece40
2 doilies50
2 tray cloths	1.00

VIII. MISCELLANEOUS

1 "First Aid" cabinet	10.00
1 fire blanket	2.00

EQUIPMENT FOR ORDINARY CLASS-ROOMS

In some schools it is impossible to set aside a special room for Household Management work, and the ordinary class-room is all that is available. In such cases the equipment must be a movable one, and gas stoves and plumb-

ing are impossible. Table tops may be placed on trestles or laid across the ordinary desks, and oil or alcohol lamps must be used. These and the necessary utensils may be kept in a cupboard in the room.

With certain restrictions, the Department of Education assists in equipping special rooms in villages and rural districts and also in maintaining instruction in this subject.

The classes in these schools are usually smaller, so that



Modified equipment for rural schools

an outfit suitable for individual work with a class of twelve will generally suffice. The following, suggested by the Macdonald Institute, Guelph, is a good basis and may be modified as desired:

12 bowls, brown	\$0.85	12 case knives	1.25
12 bread tins95	12 paring knives	1.25
12 tea cups and saucers		1.25	12 plates85
12 tin measuring cups		1.25	12 saucepans	1.68
12 egg beaters30	12 tablespoons50
12 forks40	24 teaspoons40

HOUSEHOLD MANAGEMENT

12 wooden spoons60	4 brushes20
12 stew pans	2.40	2 stove mitts50
12 strainers65	4 asbestos mats20
2 trays80	1 corkscrew25
1 bowl, yellow25	4 egg beaters60
1 " "35	4 wash basins92
1 " "45	3 draining pans69
3 scissors	1.50	4 dish pans	2.00
5 trestle tables	20.55	6 hrollers48
6 frying-pans90	3 cake tins35
3 tea strainers15	4 graters40
3 match-box stands..	.24	3 strainers75
1 emery knife20	24 patty pans20
3 soap dishes25	2 tin dippers40
12 pepper shakers ...	1.50	2 fibre pails70
12 salt shakers	1.50	1 colander35
1 bell50	1 pail, enamel70
4 lemon reamers40	1 pan, enamel18
6 stoves, kerosene...	6.00	3 tea-kettles	2.70
12 plates, dinner	1.25	1 saucepan30
6 plates, soup60	1 saucepan25
4 jugs60	1 saucepan23
1 jug45	1 saucepan30
1 butcher knife30	1 double boiler85
1 French knife60	1 kettle, covered60
2 spatulas80	*1 stove to burn coal	
6 teaspoons10	or wood	30.00
3 tablespoons13		
		Total	\$100.05

*The above may be replaced by a twenty-dollar wood stove or a ten-dollar, two burner, coal-oil stove.

PACKING-BOX EQUIPMENT

When even the expense of the modified equipment is too great, the ingenuity of the teacher and the pupils may be used to provide a "packing-box" equipment suitable for six pupils. The outlay for this will vary according to

what is provided, but it can in no case be large. The following equipment used by the Department of Domestic Science, Teachers' College, Columbia University, will be suggestive:



Packing-box equipment

FOR CLASS

3 bread boards	\$0.15	6 muffin tins12
1 rolling-pin05	2 layer-cake tins10
3 baking-powder can tops, for cookie cutters	3 dish pans45
1 flour sifter10	3 rinsing pans30
1 large frying-pan....	.25	1 strainer05
1 double boiler50	6 china plates30
1 quart kettle25	3 mixing bowls30
1 tea-kettle50	6 sauce dishes15
1 broiler20	6 cups and saucers ..	.30
1 garbage can25	1 coffee-pot25
2 pitchers25	1 tea-pot10
2 apple corers10	3 bread pans15
1 chopping knife10	6 quart jars30
1 chopping bowl05	3 wooden pails with covers30
		6 dish towels48

HOUSEHOLD MANAGEMENT

3 dish cloths15	1 bread knife25
3 hand towels15	1 corkscrew10
1 broom30		
1 dust-pan08	Total	\$8.02
1 scrubbing-brush10	1 packing-box table..	1.00
1 scrubbing pail20	1 packing-box cup-	
1 Dover egg beater..	.09	board50
1 pepper shaker05		
1 salt shaker05	Large blue-flame oil	
1 baking dish10	stove	\$10.00

INDIVIDUAL EQUIPMENT FOR SIX PUPILS

1 white bowl, 1 qt... \$0.07	1 tablespoon03
1 measuring cup	2 teaspoons05
1 granite plate		
1 saucepan	Total60
1 tir. cover		
1 steel fork	1 oil stove75
1 steel knife	1 asbestos mat05

.25
.10
8.02
1.00
50
0.00
03
05
60
75
95

CHAPTER II

SUGGESTIONS FOR CLASS MANAGEMENT

TEACHERS' PREPARATION

IN NO subject is careful planning of the details of the lesson more important than in Household Management. The definite length of the period allowed in the school programme for this work makes economy of time absolutely necessary. The cooking processes cannot be hurried, and unless there is in the teacher's mind a well-arranged plan for the use of the time, a part of the lesson is apt to be hastily and carelessly done. Then, too, in the limited space of one room, a number of people cannot work without confusion unless there is system.

The pupils enjoy a well-regulated lesson and their co-operation is gained, while, through the poor results of a lesson indifferently planned, they lose self-confidence and the sense of responsibility.

NUMBER IN THE CLASS

As a Household Management class is one that calls for individual supervision, the number should not exceed twenty-four, and a smaller class ensures more thorough supervision on the part of the teacher. Neatness, thoroughness, and accuracy are important factors in the work of each lesson, and the number of pupils should not be so large that a lack of these will pass unnoticed.

UNIFORMS, ETC.

The uniform consists of a large, plain, white apron with a bib large enough to protect the dress, a pair of sleevelets, a holder, a small towel for personal use, and a

white muslin cap to confine the hair. (See Frontispiece.) Each pupil will also require a note-book and pencil for class, and a note-book to be used at home for re-copying the class work in ink. These books should be neatly written and kept for reference, and should be regularly examined and marked by the teacher for correction by the pupils.

The pupils should be encouraged to be clean and neat in appearance. They should be expected to have tidy hair, clean hands and nails, and neat uniforms. It is a good plan for each pupil to have two sets of uniforms, so that when one is in the wash the other will be ready to use. It may be wise to make a rule that the pupils without uniforms will not be allowed to work, but such a rule must be judiciously enforced, as in some cases it might result in much loss of time. There should be lockers or other proper provision provided at the school for keeping each uniform separately. Pasteboard boxes may be used for this purpose, when no such provision is made.

DISCIPLINE

The pupils should be trained to enter and leave the room in the same order as in their other classes. Each pupil should have a definite working place and should not be allowed to "visit" others during the class.

While at work, it is wise to allow the pupils as much freedom in talking and movement as possible, so as to portray the home life. They should be taught, however, that when their conduct interferes with the order of the room or the comforts and rights of others, they must suppress their inclinations. During the time of teaching there must be perfect quiet and attention. Marks are sometimes given to secure punctuality and good work,

but the best way to have both is to try to make each member of the class interested and happy in her work.

DIVISION OF THE PERIODS

The time given to a practical lesson is usually one and a half hours. This must include both the theoretical and the practical work. In dividing the period, it is difficult to say how much time should be given to each of these, but, broadly speaking, the theoretical part may occupy one third of the time. The time for dish washing and cleaning will be included in the time allowance for practical work. These duties should require less time as the class advances in the work.

Notes should be copied at the most convenient time, usually while the food is cooking. Sitting to write notes will afford an opportunity for resting after any practical work. If printed cards are used, much of the note-taking is obviated. A sample card is given below.

HOUSEHOLD MANAGEMENT

JUNIOR FOURTH CARD

VEGETABLE WATER SAUCE

- | | | |
|-----------------|--------|-------------------------|
| 1 c. veg. water | pepper | 2 tbsp. butter |
| 2 thsp. flour | | $\frac{1}{2}$ tsp. salt |

1. Put the vegetable water over a gentle heat.
2. Mix the flour with a little cold water until smooth and thick as cream.
3. When the vegetable water is steaming hot, gradually stir the flour paste into it and keep stirring until it thickens and boils.
4. Add the butter, salt, and pepper.
5. Pour the sauce over the hot vegetable.

ASSIGNMENT OF WORK

For practical work there are two plans in general use—individual and group work. In individual work, each pupil performs all the processes, handling small quantities of material. In group work, the pupils work in groups on one dish, each sharing the duties.

By the first method, the pupil has no chance to deal with quantities large enough for family purposes, and the small amount does not give adequate practice in manipulation, though it does give individual responsibility in every detail. By the second method, normal quantities are used, but a pupil never has entire responsibility throughout the processes.

The cost of supplies is often accountable for group work, but lack of utensils or oven room may make it a necessity. In some lessons, individual work with normal quantities may be obtained by allowing the pupils to bring the main ingredients from home; for example, fruit for a canning lesson. The finished product is then the property of the pupil who has made it.

The cleaning which always follows the use of the equipment is preferably done in groups. For instance, if there are groups of fours, number one can, during a lesson, wash all dishes used by the four, number two can wipe the dishes, number three can clean the table used by the group, and number four can clean the sink. During the next lesson number two is dish washer, and number three dish wiper, and so on, until, in four lessons, each pupil has had practice in four kinds of household work and has also been given an idea of the inter-dependence of family life and interests. The same numbers should be kept during the term, as this affords an easy way of definitely designating the pupils for certain duties.

SUPPLIES

The supplies for a lesson may be put on a centre table, or smaller amounts may be placed on the working tables in front of the groups. If the class is large, the latter plan is better, especially where measurements are necessary, as it saves time and confusion. Standard food supplies, such as salt, pepper, sugar, and flour may be kept in a drawer of the work-table of each pupil. (See page 15.)

Every member of the class should be familiar with the contents of the class pantry, cupboards, and drawers, so that she can get or put away utensils and materials without the help of the teacher.

If breakages occur through carelessness, the utensils should be replaced at the expense of the offender. This is not only a deserved punishment, but it always ensures a full equipment.

PRACTICE WORK AT HOME

As a lesson in Household Management comes but once a week, much is gained by having the work reviewed by practice at home. To encourage this, in some schools a "practice sheet" is posted, on which the work done by each pupil, between lessons, is recorded. There is a danger of the younger pupils attempting work that is too difficult, which will end in poor results and discouragement. To avoid this, with pupils in the Third Form, it may be wise to limit their practice in cookery to a review of the work done in class.

The home practice work may be taken at the beginning of a lesson or during the time the food is cooking. It may be quickly ascertained by the pupils rising in order and stating simply the name of the duty they have done or the dish they have made unless they have had poor results,

when the nature of these should be told. If there have been failures, the pupils should, if possible, give reasons for these and suggest means of avoiding them in future.

GENERAL SUGGESTIONS

1. The teacher should endeavour to plan lessons which will be definitely related to the home lives of the pupils. What is useful for one class may not be useful for another. The connection between the lessons and the home should be very real. It is also important to have a sequence in the lessons.
2. Great care should be exercised in criticising any of the home methods that are suggested by the pupils. A girl's faith in her mother should not be lessened.
3. The work should be taken up in a very simple manner; scientific presentation should be left for the high school.
4. Economy should be emphasized in all home duties; time, labour, and money should be used to give the best possible returns. Wholesome substitutes for expensive foods and attractive preparation and serving of left-over foods should be encouraged.
5. Too much vigilance cannot be exercised during the first year of practical work, when habits are being formed. It is much easier to form habits than to break away from them.
6. While nothing less than the best work should be accepted from the pupils, it requires much discernment to know when fault should be found, in order to avoid saying or doing anything that would discourage them.
7. As Household Management is a manual subject, the teacher is advised, as far as possible, not to spend time

in talking about the work, but to have the class spend their time in doing the work.

**SUGGESTIONS FOR SCHOOLS WITH LIMITED,
OR NO EQUIPMENT**

In schools where the ordinary class-room must be used for all subjects, there are unusual difficulties in teaching Household Management. For such schools, two modified equipments are outlined.

Since such class-rooms require special arrangement for practical lessons in this subject, it would be well to take this work in the afternoon, so that part of the noon hour may be taken for preparation. Pupils who have earned the right to responsibility may be appointed in turn to assist in this duty.

In rural schools, the afternoon recess might be taken from 2.15 to 2.30 and, during this time, tables, stoves, and supplies may be placed, so as to be ready for the lesson to follow in the remaining hour and a half.

For pupils who are not in the Household Management class, definite work should be planned. They may occupy themselves with manual training, sewing, art work, map-drawing, composition, etc. In summer, school gardening may be done.

Since the end of the week, in many schools, is chosen for a break in the usual routine, Friday afternoon seems a suitable time for Household Management lessons.

Under such limited conditions, it will be necessary to group the larger pupils into one class for practical work, and it may be necessary for the pupils to take turns in working. In some cases, the teacher must demonstrate what the class may practise at home.

It will be impossible, in such schools, to cover the prescribed work. From the topics suggested in the Course of Study each teacher may arrange a programme by selecting what is most useful to the pupils and what is possible in the school.

Even in schools which have no equipment, much of the theory of Household Management can be taught and some experiments may be performed. On Friday afternoons a regular period may be devoted to this subject, when the ingenious teacher will find ways and means of teaching many useful lessons,

The following will be suggestive as suitable for lessons under such conditions:

1. Any of the lessons prescribed in the Course of Study for Form III, Junior.
2. Measuring.—Table of measures used in cookery, methods of measuring, equivalent measures and weights of standard foods.
3. Cleaning.—Principles, methods, agents.
4. Water.—Uses in the home, appearance under heat, highest temperature, ways of using cooking water.
5. Cooking.—Reasons for cooking, kinds of heat used, common methods of conducting heat to food, comparison of methods of cooking as to time required and effect of heat on food.

NOTE:—An alcohol stove, saucepan, and thermometer are necessary for this lesson.

6. The kitchen fire.—Experiments to show necessities of a fire, construction of a practical cooking stove.
7. Food.—Uses, kinds, common sources.

8. Preservation of food.—Cause of decay, methods of preservation, application of methods to well-known foods.
 9. Yeast.—Description, necessary conditions, sources, use.
- NOTE.—A few test-tubes and a saucepan are necessary for this lesson.
10. The table.—Laying a table, serving at table, table manners.
 11. Care of a bed-room.—Making the bed, ventilating, sweeping, and dusting the room.
 12. Sanitation.—Necessity for sanitation, household methods.
 13. Laundry work.—Necessary materials, processes.
 14. Home-nursing.—The ideal sick-room, care of the patient's bed, and diet.

CHAPTER III

FORM III: JUNIOR GRADE

THE PUPILS of Form III, Junior, are generally too small to use the tables and stoves provided for the other classes and too young to be intrusted with fires, hot water, etc.; but they may be taught the simpler facts of Household Management by the special teacher of the subject, or by the regular teacher in correlation with the other subjects. In either case a special room is not necessary.

If the latter plan be adopted, the following correlations are suggested:

CORRELATIONS

Arithmetic.—1. Bills of household supplies, such as furniture, fuel, meat, groceries, bed and table linen, material for clothing. This will teach the current prices as well as the usual quantities purchased.

2. Making out the daily, weekly, or monthly supply and cost of any one item of food, being given the number in the family and the amount used by each per day.

Example: One loaf costs 6c. and cuts into 18 slices, Find the cost of bread for two days for a family of six, if each person uses $1\frac{1}{2}$ slices at one meal.

3. Making out the total weekly or monthly expenses of a household, given the items of meat, groceries, fuel, gas, etc. This brings up the question of the cost of living.

4. Making out the total cost of a cake, a loaf of bread, a jar of fruit, or a number of sandwiches, given the cost

of the main materials and fuel used. Compare the home cost with the cost at a store. This may be used to teach economy.

Geography.—1. The sources of our water supply.

2. The geographical sources of our ordinary household materials, their shipping centres, the routes by which they reach us, and the means of transportation.

Examples: Fuels, common minerals used in building and furnishing; timber for floors and furniture; manufactured goods, such as cotton, linen, carpets, china; domestic and foreign fruits; common groceries, such as salt, sugar, tea, coffee, cocoa, spices, rice, cereals, and flour.

3. The preparation of our common household commodities.

Examples: Cotton, linen, china, paper, sugar, tea, coffee, cereals, flour.

4. The household products that are exported.

Nature Study.—1. The parts of plants used as food.

2. The natural sources of our common foods, such as cornstarch, flour, breakfast cereals, tea, coffee, cocoa, sugar, salt, cheese, butter.

3. The sources of common household substances, such as coal-oil, gasolene, paraffin, turpentine, washing soda, whiting, bathbrick, soap.

4. The forms of water, as ice, steam.

5. The composition and impurities of the air.

6. The ordinary woods used in house building and furnishing.

Hygiene.—The necessity for the following:

1. Fresh air in the home at all times—in living rooms and sleeping rooms
2. Good food and plenty of sleep
3. Cleanliness of the body
4. Cleanliness in preparing food
5. Cleanliness in the home and surroundings.

Physical Training.—1. The value of exercise gained by performing household duties.

2. The importance of correct positions in performing home duties, such as dish washing, sewing, etc.
3. The value of conveniences to save steps.

Composition.—Topics selected from household materials and activities.

Examples: Food materials, cleansing agents, planning a convenient kitchen or bath-room, sweeping day, baking day, arrangement of a kitchen cupboard or clothes closet, etc.

Spelling.—Names of household articles and duties as follows:

Furniture of a special room, such as kitchen or sitting-room, kitchen utensils, contents of a kitchen cupboard, dishes and food used at a particular meal, etc.

Manual Training.—Construction of household furnishings and utensils for a doll's house from raffia, paper, and plasticine.

Art.—Designing and colouring carpets, curtains, wall-papers, book covers, dishes, tiles, ribbons, and dress materials.

Sewing.—Making the uniform for Household Management work.

If the Household Management teacher takes the work with this class, she should follow the outline of work given in the Course of Study. This outline will make the pupils familiar with the common household materials as to their sources, preparation, and cost, and when, in the next class, they deal with these materials, they will do so with more interest and intelligence. It will also draw attention to the importance of economy in time and energy. The convenience of a kitchen and the use of proper utensils to facilitate labour will impress this fact.

The lessons should be taught simply as information lessons and should be of the same length as the other studies—from thirty to forty minutes. If the usual hour and a half period be set aside for this class, the remainder of the time may be devoted to sewing.

CHAPTER IV

FORM III: SENIOR GRADE

LESSON I

SCOPE OF HOUSEHOLD MANAOEMENT

IN INTRODUCING the practical side of Household Management to a class, it is an advantage to let them have a general idea of what the subject includes. They will then work with more intelligence and usually with more interest. Then, too, the prevalent idea that the subject means only cooking will be corrected from the first.

Throughout the introduction, the teacher should not forget that she is dealing with immature minds and that the ideas must be very simply expressed. She might ask what the pupils expect to learn in this class, have them name other subjects they study in school, and in each case lead up to the *one* thing of which a particular subject treats; for example, arithmetic treats of *numbers*; geography, of the *world*; history, of *past events*. She should lead the class to see that the one thing of which Household Management treats is the *home*; and that the two great requirements for a home are the *house*, and the people who live in it, or the *occupants*.

To get the details relating to each of these two divisions, let the pupils imagine they are boarding in some locality where they decide to make a home for themselves. The first thing to be done is to choose a building lot. Then they must decide upon the kind of house they want and the plan of the house. After the house is built, it must be furnished. When the house is ready, it must be cleaned

and kept clean. As soon as the family move in, new considerations arise—they must have food, which must be bought, prepared, and served; each member of the family must be clothed and educated; they must receive proper care when sick. Only a few minutes should be spent on this introductory talk.

While the class is naturally led to think of and name these details, they should be written on the black-board in the order of development, somewhat as follows:

1. Household Management teaches us about the *home*.
2. A home includes two main ideas:
 - (1) A house, (2) a family.
3. In connection with a *house* we must consider:
 - (1) The lot, (2) the plan, (3) the furnishing, (4) the cleaning.
4. In connection with a *family* we must consider:
 - (1) Food (buying, cooking, serving), (2) clothing (buying, sewing, mending), (3) education, (4) home nursing.

Tell the pupils that a housekeeper should be informed on all of these points, but little girls can expect to study only a few of them, such as questions of food, clothing, and cleaning.

SURVEY OF EQUIPMENT, UNIFORM, ETC.

Equipment.—Most of the time of the first lesson should be used in making the pupils acquainted with their surroundings and individual necessities, so that they will be ready for work the next day.

Give each member of the class a definite working place, and let her examine the contents of the cupboard

and drawers which belong to her place. Explain that the particular places which the pupils are given will be kept throughout the year, and that, while they have the privilege of using and enjoying them, they are responsible for their cleanliness and order.

Point out the remainder of the equipment—hot and cold water-taps, towel racks, class cupboard with its contents, refrigerator, large and individual stoves.

Teach each pupil how to light her stove and regulate its heat.

Uniforms, etc.—Tell the pupils that you have shown them what has been provided for them, but you want them also to provide some things for themselves. It will be necessary for them to bring a large, plain, white apron, having a bib large enough to protect the dress; a pair of sleevelets; a holder; a small towel for personal use; and a white muslin cap to confine the hair while working. They will also need a note-book and pencil for class, and a note-book to be used at home for re-copying the class work in ink. The latter book is to be very neatly written and kept for reference after it has been examined by the teacher.

LESSON II

USE OF EQUIPMENT

The little girls who make up the classes are not so far removed from their "playhouse" days that a survey of the dishes, stoves, and tables will not give them an eager desire to begin using them. This desire should be gratified, but as the use always necessitates the cleaning as well, it may be advisable at first to make use of the equipment only for the purpose of showing proper methods of cleaning.

A short lesson on cleaning may be given in a few minutes, and the rest of the period spent in putting it into practice. The teacher may proceed somewhat as follows in the development of a lesson on cleaning:

DEVELOPMENT OF A LESSON ON CLEANING

MEANING OF CLEANING

Take two dishes—plates or saucers—exactly alike. Have one clean and the other soiled with butter or some well-known substance. Ask the class the difference between them. One is clean and one dirty. What substance is on one that hinders your saying it is clean? Butter. What else could be on it? Jam. What else? Dust. What else? Gravy. Now instead of telling the name of the particular substance in each case, let us try to find one name that will apply to all of the substances which, as you say, make the dish dirty. Let us give these substances a name which will show that they do not belong to the plate. We may call each of them a foreign substance. And if I take the substance off the plate what am I doing to the plate? Cleaning it. Then what is cleaning? Cleaning is removing a foreign substance.

METHODS OF CLEANING

1. *Scraping or rubbing away the foreign substance:*

What would you use to remove the butter from the plate? A piece of paper or a knife. What are you doing with the knife or paper? Scraping or rubbing off the foreign substance. Then how was it removed? It was removed by scraping or rubbing.

Suppose some one has sharpened a pencil and let the pieces fall on the floor, what would you take to remove the foreign substance from the floor? A broom. What

would you say you are doing with the broom? Sweeping. How does the movement of the broom over the floor compare with the movement of the knife over the plate? It is similar. What would you take to remove the dust from the window-sill? A duster. What would you say you are doing? Dusting. How does the movement of the duster compare with the movement of the knife and the broom? It is similar. In all of these cases of dish, floor, and sill, how did we remove the foreign substance? We scraped or rubbed it off. Name one way of removing a foreign substance. Scraping or rubbing it away.

2. *Dissolving the foreign substance and then scraping it away:*

Show a much soiled towel and ask what is usually done to clean it. It is washed. Ask the pupils to tell just what they mean by that. The towel is put in water and soap used on it. What effect will the soap and water have on the foreign substance? They will soften or dissolve it. Then what must be done next? The towel must be rubbed on a board or with the hands. What effect has this operation on the foreign substance? It scrapes or rubs the foreign substance away. Then we have another way of cleaning: By first dissolving the foreign substance, and then scraping or rubbing it away.

A number of well-known cleaning operations may then be given, and the pupils asked in each case to decide the method used—such as, whisking a coat, scrubbing a table, cleaning the teeth, or washing dishes.

COMMON HOUSEHOLD CLEANSING AGENTS

Next, get lists of the common cleansing agents found in an ordinary home, and arrange them in order of coarseness.

BLACK-BOARD OUTLINE

The black-board scheme, as the lesson develops, will appear as follows:

1. *Meaning of Cleaning:*

Cleaning is removing any foreign substance.

2. *Methods of Cleaning:*

- (1) Scraping or rubbing away the foreign substance.
- (2) Dissolving the foreign substance and then scraping or rubbing it away.

3. *Household cleansing agents used in the first method:*

- | | |
|---------------|-----------------|
| (1) Duster | (6) Whiting |
| (2) Brush | (7) Bathbrick |
| (3) Broom | (8) Coarse salt |
| (4) Washboard | (9) Sand |
| (5) Knife | (10) Ashes. |

4. *Household cleansing agents used in the second method:*

- | | |
|---------------|------------------|
| (1) Water | (7) Washing soda |
| (2) Hot water | (8) Coal-oil |
| (3) Sosp | (9) Gasolene |
| (4) Lux | (10) Acids |
| (5) Ammonia | (11) Lye. |
| (6) Borax | |

5. *Combination cleansing agents:*

- (1) Bon Ami, (2) Dutch Cleanser, (3) Sapolio.

When the class have these ideas, they are ready to put them into practice, and the remainder of the lesson should be spent in practical work.

If the pupils have soiled no dishes, it may be wise to drill them first in table washing or towel washing, so as to get them ready for the next lesson when tables and towels will be used.

LESSONS III, IV, ETC.

Gradually, in connection with the making of simple dishes, the pupils should be taught special methods of dish washing, sink cleaning, and dusting. Each day as they are appointed to different duties in cleaning, these methods should be strictly followed until they become well known.

While they are still new to the class, it will be a great help to have outlines of the kinds of cleaning which are necessary in every lesson posted conveniently in different parts of the room for reference.

These outlines may be as follows:

DISH WASHING

Preparation for washing:

1. Put away the food.
2. Scrape and pile the dishes.
3. Put the dishes that need it to soak.
4. Place soap, pans, brushes, and towels.
5. Put water in the pans.

(1) Fill the dish pan about half full of warm water, then soap it.

(2) Fill the rinsing pan nearly full of hot water.

Order of washing:

- | | |
|-------------|----------------------------|
| 1. Glass | 5. Granite ware |
| 2. Silver | 6. Tins |
| 3. China | 7. Pots |
| 4. Crockery | 8. Steel knives and forks. |

Finishing after washing:

1. Soap a dish cloth and wash the sides and bottom of the dish pan, before emptying it.
2. Empty the dish pan, rinse at the sink, and half fill with clear, warm water, to rinse the towels.
3. Wash the towels in the rinsing pan, rinse them in the dish pan, shake them straight, fold, and hang.
4. Soap the dish cloth, wash the inside of the rinsing pan, empty, rinse, and wipe with the dish cloth.
5. Wash and wipe the soap dish.
6. Empty the dish pan and wipe with the dish cloth.
7. Pile the pans, place the brushes and soap, and set away.
8. Fold the dish cloth and hang it to dry.

TABLE CLEANING (CLASS WORK)

1. If necessary, scrape or brush off the table stoves.
2. Get a scrub cloth, a wash-basin of warm water, and a scrub-brush.
3. Wash the part of the table used by your group, doing the part not occupied by the dish washing first; then get the dish washers to move along, so that you can finish it, proceeding as follows:
 - (1) Wet the table all over.
 - (2) Rub the soap cake over it.
 - (3) Scrub with the wet brush with the grain of the wood.
 - (4) Rinse the soap off with the clear water.
 - (5) Wipe with the cloth wrung dry.
4. Get clear water. Rinse the brush and put it away. Rinse the scrub cloth and wring it dry.
5. Take the basin and cloth to the sink. Empty, rinse the basin, and dry it with the cloth. Rinse the cloth under the tap and wring it dry.

6. Fold and hang the cloth to dry. Bring back a dry cloth and thoroughly dry the aluminium strip.
7. Put away the dry cloth and basin.

SINK CLEANING

1. Let the other housekeepers get the water they need.
2. Get a sink pan, a scrub cloth, and a brush. Put warm water in the pan.
3. Scrub the drain board if there be one, as follows:
 - (1) Wet the board all over.
 - (2) Rub the soap cake over it.
 - (3) Scrub with a wet brush with the grain of wood.
 - (4) Rinse the soap off with clear water.
 - (5) Wipe with the cloth wrung dry.
4. Wash the nickel part of the sink (tap and stand) with soap. Wipe with the cloth wrung dry.
5. Wash the outside of the basin of the sink.
6. When the other housekeepers have emptied their water, wash the inside of the sink basin and wipe with the cloth wrung dry.
7. Wash the scrub cloth and pan, rinse the brush, and put all away.
8. Polish the nickel with a dry duster.

DUSTING

1. Get a cheesecloth duster.
2. Dust the chairs and put them in place.
3. Dust the table legs and drawer handles.
4. Dust the cupboard and refrigerator.
5. Dust the wood-work, window-sills, ledges, etc.
6. Wash the duster and hang it up to dry.

MEASURES AND RECIPES

Another preliminary part of the work will be teaching the pupils to measure and follow a recipe.

MEASURES

The measures used in kitchen work are teaspoon, tablespoon, pint, quart, and gallon, of which a table should be developed as follows:

3 teaspoonfuls (tsp.)1	tablespoonful (tbsp.)
16 tbsp.1	cup
2 cups1	pint (pt.)
2 pt.1	quart (qt.)
4 qt.1	gallon (gal.)

In connection with this table the following points should be brought out:

1. That all measurements are made level.
2. That in measuring liquids, the measure should be set on a level surface.
3. That to halve the contents of a spoon, the division should be made lengthwise.
4. That to quarter the contents of a spoon, the half should be divided crosswise.
5. That in measuring flour, it should not be shaken down to level it.
6. That in using one measure for both dry and liquid ingredients, the dry should be measured first.
7. That in measuring a cupful of dry ingredients, the cup should be filled by using a spoon or scoop.



(a) Dividing the contents of a spoon



(b) Dividing a spoonful in halves

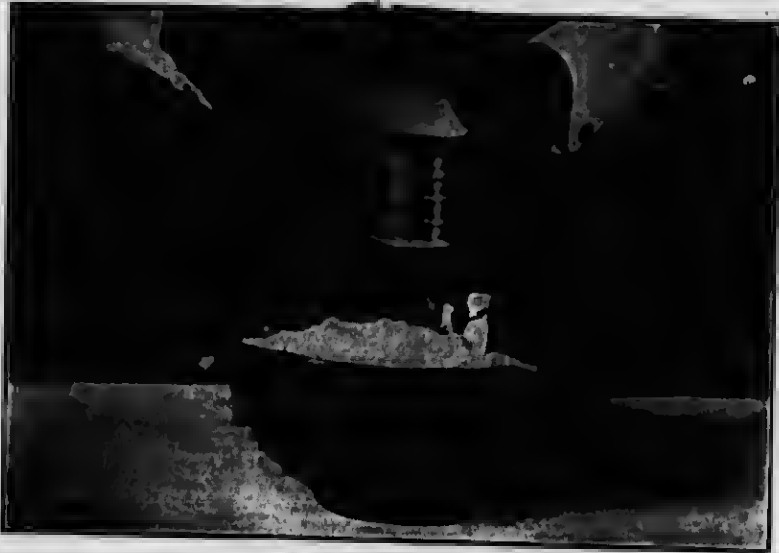

(c) Filling a cup



(d) Levelling a cupful

TABLE OF EQUIVALENT MEASURES AND WEIGHTS

A table of equivalent measures and weights of some staple foods will also be useful and may be given to the class:

2 cups butter (packed solidly).....	1 pound
2 c. granulated sugar	1 "
2 c. rice	(about) 1 "
2 c. finely chopped meat	1 "
2½ c. brown sugar	1 "
2½ c. powdered sugar	1 "
2½ c. oatmeal	1 "
2½ c. cornmeal	1 "
4 c. white flour	1 "

PLAN OF LESSON ON MEASURING

TIME LIMIT

One and one-half hours to be divided approximately as follows—one-half hour for teaching the theory, one-half hour for the practical application of the theory, and one-half hour for housekeeping (washing of dishes, tables, sinks, etc., and putting the kitchen in order).

PREPARATION

1. Place a set of measures at hand.
2. Place a large bowl of flour on the teacher's table.
3. Place flour and sugar in the boxes of the supply drawers.
4. Place cans of cocoa and jugs of milk on the centre table.

DEVELOPMENT

1. Introduction.—What do we take for a guide when cooking? How can we be sure that we use the exact

quantities the recipes require? Name some measures that you have learned in arithmetic. In this lesson we are going to learn the measures we require in cooking, also the proper ways of using them.

2. Names of measures.—Show and name the measures, beginning at the smallest: teaspoon, tablespoon, cup, pint, quart, gallon. As the measures are named, place them on the table in order of size.
3. Methods of using measures.—Ask two or three pupils, in turn, to measure a teaspoonful of flour from the bowl on the teacher's table. They will not agree in their measurements, and the necessity for levelling will be shown. What can we use for levelling measures? How can we level liquids?

If we need less than a spoonful, how can we measure it? Which part of the spoon is deeper? How shall we divide the spoonful to make both halves equal? How must we divide a spoonful into quarters? Into eighths? Examine and explain the divisions of the cup. To use one measure for both liquid and dry ingredients, which should be measured first? (As these points are obtained, they should be written on the black-board.)

4. Table of measures.—In the tables of measures which you have learned, you state the number of times one measure is contained in the next higher. We shall form a table of the measures learned to-day. By measuring flour from their boxes, let each pupil find how many teaspoonfuls fill a tablespoon. How many tablespoonfuls fill a cup, a half cup, a quarter of a cup. They will state the remainder of the table from memory. Write the table on the black-board and teach the abbreviations.

NOTE.—After the lesson on measuring is developed, the class should be given individual work which will put these ideas into practice. A simple recipe may be dictated by the teacher, step by step. Cocoa makes a good recipe for this lesson, as it affords practice in measuring liquids as well as dry ingredients, both powdered and granular. If each girl makes half a cupful of cocoa, it will give practice in dividing the contents of a spoon.

PRACTICAL WORK TO APPLY MEASURING

Have each pupil make half a cupful of cocoa by carrying out each step as it is dictated by the teacher, as follows:

1. Numbers one put two cups of water in the tea kettle; numbers two light a fire and put the water to boil; numbers three get cocoa from the centre table; numbers four get milk.
2. Set out sugar boxes and open them.
3. Each take a small saucepan, a measuring eup, a teaspoon, a paring-knife, and a small eup.
4. Measure half a teaspoonful of sugar into the saucepan.
5. Measure half a teaspoonful of cocoa into the saucepan.
6. Mix the sugar and cocoa by shaking the saucepan.
7. Measure half of a third of a eupful of boiling water and stir it into the sugar and cocoa.
8. Set the mixture over a gentle fire and stir until it bubbles. Cook for three minutes.
9. Measure half of a third of a eupful of milk.
10. Stir the milk into the mixture and heat it until it is steaming hot, but do not boil it.
11. Serve the cocoa in the small eups.
12. Turn out the fires and put the saucepans to soak.

SERVING

Each pupil puts her table in order by moving all cooking utensils to the metal part of the table and wiping off any soiled spots on the wooden part; she then sits to drink the cocoa she has made.

NOTE-TAKING.

Notes are copied from the black-board in pencil in the ordinary class note-books. The desk boards under the table tops are pulled out for this purpose. In this lesson the notes consist of:

1. Table of measures, with abbreviations
2. Points in measuring
3. Recipe for cocoa (if there are recipe cards, these should be distributed).

HOUSEKEEPING

This will be done in groups of fours, according to their previous lessons in cleaning. If necessary, some special cleaning, as dish washing or sink cleaning, may be taught at this point of the lesson:

1. Number one will wash dishes for her group.
2. Number two will wipe dishes for her group.
3. Number three will clean the entire table belonging to her group.
4. Number four will do work outside of her group as appointed, such as dusting, cleaning a sink or the centre table.

RECIPE FOR COCOA

1 tsp. sugar $\frac{1}{2}$ c. boiling water
1 tsp. cocoa $\frac{1}{2}$ c. milk.

1. Mix the sugar and cocoa in a saucepan.
2. Stir the boiling water into the mixture, then set it over a gentle heat.
3. Keep stirring until the mixture bubbles, then boil gently for about three minutes.
4. Stir in the milk and heat it until it steams, but do not boil it.
5. Serve the cocoa hot or ice-cold.

RECIPES

In connection with a recipe, the pupils should be taught to look for three parts:

1. The name
2. The list and amount of ingredients
3. The method.

In carrying out a recipe, they should, from the first, be taught to work in the following systematic order:

1. To attend to the fire if necessary
2. To collect the necessary utensils
3. To collect the necessary ingredients
4. To obey the method.

For this lesson, some simple recipe which will review measuring should be clearly written on the black-board—the recipe for apple sauce or cranberry sauce would be suitable. While the pupils are learning obedience in following a recipe, it is better to keep them together in carrying out their work. The method should be written in definite, numbered steps, which may be checked off as each step is accomplished.

When the class has had instruction in cleaning, measuring, and recipes, they are ready for a series of lessons involving the use of simple recipes which will put into practice the ideas they have learned. For this practice, such recipes as the following are suggested:

Boiled potatoes, mashed potatoes; boiled parsnips; boiled celery; boiled carrots, asparagus, green peas; cranberry sauce; rhubarb sauce; preparing and combining ingredients for salads (fruit salad, potato salad, cabbage and nut salad, Waldorf salad)—the dressing being supplied; stuffed eggs; sandwiches.

The carrying out of these lessons will develop in the pupils accuracy and obedience, and make them familiar with the use and care of their utensils, as well as give opportunity for the cleaning of these and other parts of the equipment.

During these first lessons, careful supervision should be given each pupil, so that only correct habits may be formed in regard to neatness, thoroughness, quietness, and natural use of muscles.

The pupils should be encouraged to begin a book of recipes to contain neatly written copies of all they have used in school. The Art teacher might correlate the work here by assisting them to design a suitable cover for this book.

CHAPTER V

FORM III: SENIOR GRADE (Continued)

COOKERY

LESSON I

AFTER a number of practice lessons have developed in the pupils a certain ability and self-confidence in working, formal cookery may be introduced, and the following ideas should be brought out:

1. The meaning of cooking:
Cooking is the application of sufficient heat to make a change in the food.
2. Reasons for cooking food:
 - (1) To make some food digestible.
 - (2) To change flavours and make some food more appetizing.
 - (3) To preserve food.
 - (4) To kill harmful germs in food.
3. Kinds of heat used:
 - (1) Dry heat—heat, only, is conveyed to the food.
 - (2) Moist heat—heat and moisture are conveyed to the food.
4. Different ways of applying *dry heat*:
Toasting, broiling, pan-broiling, sautéing, frying, baking.
5. Different ways of applying *moist heat*:
Boiling, simmering, steaming, steeping.

NOTE.—If the class cannot name these methods, the teacher may name and write them with only a word of comment regarding each, or they may not be given until the methods are studied.

As the moist heat methods are simpler and better known, they should be studied first. The class should be led to see that some liquid must be used to supply the moisture and should account for the common use of water for this purpose. Experiments should then be performed in heating water, and its appearance and temperature should be noted.

NOTE.—A preliminary lesson on the use of the thermometer may be necessary to show how to read it, and to develop the idea that it is an instrument for measuring heat. This may be taught in the regular class work, previous to the Household Management lesson.

LESSON ON THE THERMOMETER

1. Development of the idea of "measuring":

What would you use to measure the length of the table? A foot measure. What to measure the water in a tub? A pint, quart, or gallon measure. What to measure the amount of gas burned? A gas-meter.

2. Development of the name "thermometer":

What do we call the instrument

For measuring gas? A gas-meter

For measuring electricity? An electrometer

For measuring speed of a motor? A speedometer
(speed-meter)

For measuring the distance a bicycle travels? A
cyclometer (cycle-meter).

In each case what does "meter" mean? It means an instrument for measuring. What name may I give to an instrument for measuring heat? You may call it a heat-meter.

Tell the pupils that, in science, many Greek words are used, and that you will put a Greek word in place of the English word "heat", namely "thermos", as in thermos bottle. What will the name become? Thermos-meter, or *thermometer*.

3. Practice in using thermometers :

The unit of measurement (*degree*) should be given, and the scale taught from the black-board. Thermometers may then be given to the class to examine and use.

Saucepans having white inner surfaces are best to use for the experiments, as changes made by the heat are more plainly seen.

Observations of water under heat :

- (1) At a temperature of about 100 degrees, very small bubbles form at the bottom and sides of the dish and rise slowly to the surface of the water. These bubbles are a film of water containing the air that was in solution, which, when expanded, rises to the top of the water.
- (2) At a temperature of about 180 degrees, a few larger bubbles form at the bottom of the dish and rise slowly to the surface of the water, making a slight movement in it. In these bubbles air is replaced by steam which is formed from the water by the heat.
- (3) At a temperature of 212 degrees, a great number of large bubbles form and rise quickly to the surface, making much movement in the water. The water is then said to boil.
- (4) The water will take no higher temperature than 212 degrees.

- (5) After water once boils, it requires little heat to keep it at this point, therefore the heat may be reduced.
- (6) An increase of heat increases the number, size, and rate of the bubbles and the volume of steam, but makes the liquid no hotter.

Application of these observations:

- (1) If food be cooked in a liquid at its greatest heat, where many bubbles are making much movement in it, the process is called *boiling*.
- (2) If cooked in a liquid heated to 180-200, where there is scarcely any movement in the liquid, the process is called *simmering*.
- (3) If cooked in the steam rising from a boiling liquid, the process is called *steaming*.
- (4) If boiling liquid be poured over food and no further heat applied, the process is called *steeping*.

LESSONS II, III, IV, ETC.

Practice should then be given in each of the moist heat methods of cooking. The common foods, such as vegetables, fruit, eggs, and milk should be used for this purpose.

After the class has carried out a method for the first time, they should be led to consider the order of work required for it. The necessary steps should be arranged to form a set of rules for reference. The effects of the method in each case should also be noted.

When the moist heat methods are well known, the dry heat methods should be taught and practised. The outlines on pages 73-81 will suggest the development under each method.

HOUSEHOLD MANAGEMENT

PLAN OF LESSON ON BOILING CARROTS

AIM

To apply the principles of boiling, as taught in a previous lesson, to the cooking of food.

TIME LIMIT

One and one-half hours to be used approximately as follows: twenty-five minutes for preparation for practical work and the first part of the practical work, twenty-five minutes for the development of ideas of boiling as a method of cooking, fifteen minutes for the serving of food, twenty-five minutes for housekeeping.

PREPARATION FOR PRACTICAL WORK

1. Review.—Question the pupils as follows: What kind of heat is used in cooking food by boiling? At what temperature is the food cooked by this method? Name the kinds of boiling. How much hotter is rapid boiling? How is water made to boil rapidly? When is rapid boiling useful?
2. Discussion of recipe.—Have the recipe written on the black-board and read by one of the pupils, while the others follow the reading carefully.
 - (1) Have the class decide:
 - (a) When the fires should be lighted
 - (b) The dishes required for the work
 - (c) The kind of boiling to use.
 - (2) Demonstrate the scrubbing, scraping, and dicing of a carrot, also the draining of a food cooked in liquid.

- (3) State the quantity of ingredients each will use.
- (4) Caution the pupils as to accuracy, neatness, and quietness while working.

PRACTICAL WORK

Have each pupil prepare the food according to the recipe and put it on to cook within a certain time. While the class works, carefully observe each pupil and give individual help to those who require it.

DEVELOPMENT OF THE IDEAS OF BOILING
AS A METHOD OF COOKING

This will be done while the carrots are cooking. The ideas brought out from review and the class work, by questioning, will be those which are given on boiling under the methods of cooking.

1. Definition of boiling
2. Kinds of boiling
3. Uses of rapid boiling
4. Rules for boiling
5. Effects of boiling.

As these ideas are obtained from the class, they should be written by the teacher on the black-board and by the pupils in their note-books.

SERVING

The pupils will drain, season, and serve the food. Each girl will set one place on the wooden part of the table and serve herself. While the food is being eaten, the table manners of each girl should be observed, and, if necessary, corrected in a tactful manner.

HOUSEKEEPING

The work of putting the kitchen in order may be done in groups of twos or fours.

RECIPE: BOILED CARROTS

Carrots	Salt and pepper
Boiling water	Butter.

1. Scrub, scrape, and rinse the carrots.
2. Cut them into pieces by dicing them.
3. Put the pieces in a saucepan, set over the fire, and pour in boiling water until the food is covered.
4. Cook the carrots until the pieces are soft at the centre when pierced with a fork.
5. Drain off the liquid, then season the food with salt, pepper, and butter.
6. Serve in a hot vegetable dish.

PLAN OF LESSON ON SIMMERING: APPLES

INTRODUCTION

1. Review:
 - (1) Appearance and temperature of a boiling liquid.
 - (2) Appearance and temperature of a simmering liquid.
2. State the difficulty of keeping a liquid at simmering temperature; show the double boiler and explain its use for this purpose.
3. Compare boiling and simmering as to length of time required and difficulty.
4. Tell the pupils they are going to study simmering by making Coddled Apples.

DISCUSSION OF RECIPE

1. Read recipe.
2. Question regarding:
 - (1) Kind of heat used
 - (2) Whether to prepare apples or syrup first, and why
 - (3) Management in measuring so as to use only one cup
 - (4) Why one quantity of syrup is sufficient for so many apples.
3. Decide on the dishes required for the work.

PRACTICAL WORK

Assign work in groups of twos—numbers one and three prepare syrup; numbers two and four prepare apples; all attend to the cooking.

DEVELOPMENT OF IDEAS OF SIMMERING

(To be dealt with while food is cooking)

1. Definition.—Obtain this by comparing simmering with boiling.
2. Effects:
 - (1) Compare a raw and simmered apple to get the idea of "soft and tender".
 - (2) Tell the pupils simmering temperature will not harden and toughen meat and eggs as much as boiling does.
 - (3) Lying longer in the liquid to cook dissolves out more of the food substance.
 - (4) Less water going off as vapour does not carry away as much flavour.
 - (5) Less motion in the liquid does not break up the food.

SERVING

When the apples are tender, let each girl serve herself with what she has cooked. While the fruit is being eaten, direct attention to the flavour of apple in the syrup.

HOUSEKEEPING

Assign the work which is necessary to put the kitchen in order, and allow the pupils to carry it out in groups of twos or fours.

RECIPE (INDIVIDUAL) : CODDLED APPLES

1 apple
 $\frac{1}{2}$ c. sugar
 $\frac{1}{2}$ c. water.

1. Put the sugar and water in the inside part of a double boiler, set over the fire, and boil gently for about five minutes.
2. Wash and pare the apple, cut it into halves, and remove the core.
3. Put the prepared fruit into the syrup, cover the dish closely, and set in the under part of the double boiler.
4. Simmer the pieces of apple until tender, turning them occasionally.
5. Lift the fruit carefully into a serving dish, then pour the syrup over it.
6. Serve hot or cold.

NOTE.—One cup of sugar will make sufficient syrup for six or seven apples.

METHODS OF COOKING: DETAILS

BOILING

1. Definition:

Boiling is a method of cooking in which the heat reaches the food through a boiling liquid.

2. Kinds of boiling:

- (1) Gentle boiling—temperature of 212 degrees.
- (2) Rapid boiling—temperature of 212 degrees.

3. Uses of rapid boiling:

- (1) To make much steam
- (2) To break up food
- (3) To keep small particles of food in motion.

4. Rules for boiling:

- (1) Put the food in a cooking dish, set over the heat, and pour in the boiling liquid to cover the food well.
- (2) Regulate the heat to the kind of boiling required.
- (3) Keep the food boiling during the entire cooking.
- (4) Continue the cooking until the food is tender at the centre when it is tested, or for the time required by the recipe.
- (5) When the food is cooked, lift it from the liquid or drain the liquid from the food.

5. Effects of boiling:

- (1) It makes some food soft and tender—fruit, vegetables.
- (2) It makes some food hard and tough—eggs, etc.
- (3) It breaks up food.
- (4) It dissolves out some of the food substance.
- (5) It causes some loss of flavour (in the steam).
- (6) It kills germs.



MICROCOPY RESOLUTION TEST CHART

(ANSI and ISO TEST CHART No. 2)

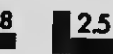
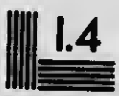
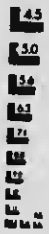
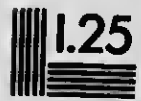

APPLIED IMAGE Inc

1653 East Main Street
Rochester, New York 14609 USA
(716) 482 - 0300 - Phone
(716) 288 - 5989 - Fax

SIMMERING

1. Definition:

Simmering is a method of cooking in a liquid at a temperature of about 180 degrees.

2. Rules for simmering:

- (1) Use a double boiler to keep the temperature correct.
- (2) Put the food in liquid in the top dish, and proceed as in boiling.

3. Effects of simmering:

- (1) It makes some foods soft and tender—fruit and vegetables.
- (2) It does not make the protein of animal food (milk, eggs, and meat) hard as boiling does.
- (3) It dissolves out a good deal of the food substance into the cooking liquid.
- (4) It causes very little loss of flavour.
- (5) It does not break up the food.

STEAMING

1. Definition:

Steaming is a method of cooking in the steam from boiling liquid.

2. Rules for steaming:

- (1) Have the water boiling rapidly in the under part of the steamer.
- (2) Put the food in the upper part, cover closely, and place over the lower part.
- (3) Keep the water boiling rapidly during the entire cooking.

- (4) If extra water be needed, only boiling water should be added, as quickly and as gently as possible.
- (5) Continue the cooking according to the time required by the recipe, or test as in boiling, if the food permits.

3. Effects of steaming:

- (1) It makes vegetable food tender.
- (2) It makes the protein of animal food harder than simmering, but not so hard as boiling does.
- (3) It does not break up the food.
- (4) It does not dissolve out the food substance.
- (5) It causes little loss of flavour if closely covered.

STEERING

1. Definition:

Steering is a method of cooking, by pouring boiling water over food, and letting it stand in a moderately warm place.

2. Rules for steering:

- (1) Heat the steering dish.
- (2) Use water freshly boiled.
- (3) Put the food in the hot dish, pour water over, cover closely, and set in a warm place.
- (4) Let the food remain in the liquid until you have extracted what is desired.
- (5) Strain off the liquid and use as required.

3. Effects of steering:

- (1) To heat and soften the food.
- (2) To extract the flavour and, sometimes, the substance of the food.

TOASTING

1. Definition :

Toasting is a method of cooking in which the heat reaches the food directly from the fire. It is used mainly for bread.

2. Rules for toasting :

- (1) Have a clear, hot fire.
- (2) Cut bread in slices from one third to one half an inch thick.
- (3) Hold the food at some distance from the fire, in a gentle heat at first, to dry and heat the surfaces. This drying may be done in the oven.
- (4) Then hold the dried, hot surfaces in a strong heat, to brown and crisp them.
- (5) Serve so that the surfaces will not become steamed from the moisture still contained in the slices. Put the toast in a toast-rack or stack it on a hot plate. Buttered toast may be piled.

3. Effects of toasting :

- (1) To heat and dry the surface of the food.
- (2) To brown and crisp the surface.
- (3) To change the flavour.
- (4) To change the starch of the surface into a brown substance, which is a form of sugar, and more digestible than starch.

BROILING

1. Definition :

Broiling is a method of cooking in which the heat reaches the food directly. It is used mainly for meat and fish in slices or thin portions.

2. Rules for broiling:

- (1) Have a clear, hot fire.
- (2) Grease the broiler and trim the food.
- (3) Lay the food in the broiler compactly.
- (4) Hold the broiler in a very strong heat to seal the tubes of the food which hold the juices, and turn frequently.
- (5) When the surface is seared, hold in a gentler heat to cook the food to the centre, and turn occasionally while doing this.
- (6) Time the cooking to the thickness of the food—
one inch of thickness cooks rare in eight minutes.
- (7) Serve at once on a hot dish, and spread with butter, salt, and pepper.

3. Effects of broiling:

- (1) To sear the surface.
- (2) To cook to the centre while browning the surface.
- (3) To change the flavour and develop a very delicious one in the browned surface.
- (4) To make the browned surface hard to digest.

PAN-BROILING**1. Definition:**

Pan-broiling is an imitation of broiling and is a method of cooking on a hissing-hot, metal surface.

2. Rules for pan-broiling:

- (1) Have a hot fire.
- (2) Heat the pan or metal surface until it hisses when touched with water.
- (3) Lay the food in compactly, and turn constantly until the entire surface is seared.

- (4) Place the pan in a gentle heat and cook the food to the centre, turning occasionally.
 - (5) Time the cooking to the thickness of the food— one inch cooks rare in ten minutes.
 - (6) Serve at once, as in broiling.
3. Effects of pan-broiling:
The same as in broiling.

SAUTÉING

1. Definition:
Sautéing is a method of cooking in which the heat reaches the food through a smoking-hot, greased surface.
2. Rules for sautéing:
 - (1) Heat the pan enough to melt the fat.
 - (2) Put in just enough fat to keep the food from sticking, and let it run over the surface of the pan, and get smoking hot.
 - (3) Put in the food and let it brown on one side, then turn it and brown the other side.
 - (4) Serve on a hot dish.
3. Effects of sautéing:
 - (1) To sear the surface of the food.
 - (2) To brown the surface and develop a delicious flavour, while cooking to the centre.
 - (3) To make the surface slightly fat-soaked with fat which has been very highly heated.
 - (4) To make the surface indigestible.

BAKING

1. Definition:
Baking is a method of cooking in which the heat is brought to the food through the confined heat of an oven.

2. Kinds of ovens

- (1) Slow.
- (2) Moderate—white paper browns in ten minutes.
- (3) Hot—white paper browns in five minutes.
- (4) Very hot—white paper browns in one minute.

3. Rules for baking:

- (1) Heat the oven according to the recipe.
- (2) Put the food in the oven, usually on the lower shelf, to get an under heat first, then toward the last of the cooking, set it on the top shelf to brown.
- (3) Watch carefully during the baking, but in opening the oven door, be gentle and quick.
- (4) If the oven gets too hot, set a pan of cold water in it, or leave the door slightly open. If browning too quickly, cover the surface with brown paper.
- (5) Cook the food according to the time required by the recipe, or until it is done, as shown by some test.

FRYING

1. Definition:

Frying is a method of cooking in which the heat is brought to the food by immersing it in smoking-hot fat.

2. Temperature for frying:

- (1) For cooked foods which have only to brown and warm through—about 400 degrees.
- (2) For raw foods which have to cook—about 350 degrees.

3. Rules for frying:

- (1) Use a deep iron, steel, or granite kettle, which will hold the heat.
- (2) Put in sufficient fat to cover the food well, but never fill the kettle more than two-thirds full.
- (3) Heat the fat to the desired temperature.
- (4) Have the food as dry as possible and not very cold.
- (5) When the fat begins to give off a small quantity of *white* vapour, test it for the required heat, as follows:
 - (a) For raw food, put in a small square of bread, and allow it sixty seconds to brown.
 - (b) For cooked food, allow a square of bread forty seconds to brown.
- (6) Put the food carefully into the hot fat, and only an amount which will not cool it too much.
- (7) When the food is nicely browned, lift it from the fat with an open spoon or lifter and drain over the pot until it stops dripping.
- (8) Lay the food on crumpled brown paper or blotting paper, to absorb any fat still clinging to the surface.
- (9) Strain the fat through cheesecloth and set it away to cool.

4. Effects of frying:

- (1) To sear the surface and prevent it from absorbing fat.
- (2) To cook or heat the food to the centre.
- (3) To brown the surface of the food and make it crisp.

- (4) To develop a delicious flavour in the browned surface.
- (5) To make the browned surface indigestible, because it has absorbed highly-heated fat.

NOTE.—As frying requires the fat used to be at a very high temperature, it is dangerous to let young children take the responsibility in this method of cooking. For this reason, it may be wise to defer lessons on frying until the Fourth Form, or even later.

For practice in the methods of cooking, the following is suggestive :

- Boiling.**—Cooking of any vegetable or fruit in season or rice, macaroni, eggs, coffee
- Simmering.**—Dried fruit, such as prunes, peaches, apricots, apples; strong-smelling vegetables, such as cabbage, onions; porridge; stew
- Steaming.**—Potatoes, cauliflower, apples, peaches, cup-puddings, dumplings, fish
- Steeping.**—Tea, coffee, lemon rind for sauce
- Toasting.**—Bread, rolls
- Broiling.**—Steak, fish
- Pan-broiling.**—Steak
- Sautéing.**—Sliced potatoes, potato cakes, hash cakes, griddle-cakes (teacher prepares the batter)
- Baking.**—Apples, bananas, potatoes, scalloped potatoes, scalloped tomatoes, cheese crackers, drop biscuits, beef-loaf
- Frying.**—Potatoes, cod-fish balls, doughnuts (teacher prepares the dough).

The lessons which give practice in the methods of cooking will also afford excellent drills in *measuring, manipulation, and cleaning*. Throughout all these, the weak points of individual members of the class should receive careful attention. In the case of typical defects, much time may be saved by calling the attention of the class to these, instead of correcting them individually.

After the pupils have considered and practised the methods of cooking, they should be able to prepare any simple dish of one main ingredient, for which recipes should be given. If these cannot be used at school, they may be of service in the homes of the pupils.

Economy should be emphasized by suggesting simple ways of using left-overs, and definite recipes should be written for these. Fancy cooking should be discouraged. The teacher should aim to show how the necessary common foods may be prepared in a nutritious and attractive manner.

In this first year of practical work, *the main point is the formation of correct habits of work*. Cleanliness, neatness, and accuracy should be insisted on in every lesson, and deftness should be encouraged.

SUGGESTIONS FOR THE USE OF LEFT-OVERS

BREAD

1. Toast for garnishing stews and hash
2. Croutons for soup
3. Bread crumbs to use for croquettes and scalloped dishes, or for stuffing meat and fish
4. Pudding (chocolate bread pudding, cabinet pudding, plain bread pudding, brown betty)
5. Pancakes.

CAKE

1. Pudding (steamed until just re-heated and served with a sauce)
2. Pudding (baked in a custard mixture)
3. Trifle.

MEAT

1. Meat pie or potato and meat pie
2. Meat loaf
3. Stew with dumplings
4. Hash
5. Scalloped meat
6. Croquettes
7. Meat moulded in gelatine
8. Salad (light meats only)
9. Sandwiches.

FISH

1. Scalloped fish
2. Salad.

EGGS

1. Stuffed eggs
2. Hard-boiled for salad
3. Garnish for salad
4. Sandwiches.

CHEESE

1. Cheese crackers
2. Cheese straws
3. Cheese cream toast
4. Cheese omelet
5. Cheese salad
6. Welsh rarebit
7. Macaroni and cheese
8. Sandwiches.

VEGETABLES

1. Scalloped vegetable
2. Cream of vegetable soup (water in which vegetable is cooked should be kept for this)
3. Sautéd vegetables
4. Salad.

CANNED FRUIT

1. Cup pudding or roly poly
2. Steamed or baked batter pudding
3. Pudding sauce (strain juice and thicken)
4. Trifle
5. Fruit salad
6. Gelatino mould.

BEVERAGES

After the moist heat methods of cooking are learned, a special lesson on beverages may be taken, if the teacher thinks it desirable. If the subject be not taken as a whole, each beverage may be taught incidentally, when a recipe requiring little time is useful. The following will suggest an outline of facts for a formal lesson :

MEANING OF BEVERAGES

A beverage is a liquid suitable for drinking. Water is the natural beverage; other beverages are water with ingredients added to supply food, flavour, stimulant, or colour. Since water is tasteless in itself and also an excellent solvent, it is especially useful in making beverages.

KINDS OF BEVERAGES

1. Refreshing.—Pure cold water, all cold fruit drinks
2. Stimulating.—All hot drinks, tea, coffee, beef-tea, alcoholic drinks
3. Nutritious.—Milk, cocon, chocolate, oat meal and barley water, tea and coffee with sugar and cream.

NOTE.—As tea, coffee, and cocoa are ordinary household beverages, they should be specially studied. Their sources and manufacture will have been learned in Form III Junior, but their use as beverages may now be discussed and practised. It is desirable that the pupils be led to reason out correct methods of cooking each.

TEA

1. Description.—The leaves contain, beside a stimulant and flavour, an undesirable substance known as tannin, which is injurious to the delicate lining of the stomach. If the tea be properly made, the tannin is not extracted.
2. Method of cooking.—Steep the tea from three to five minutes, then separate the leaves from the liquid (suggest ways of doing this). Boiling is not a correct method to use for making tea, as it extracts the tannin and causes loss of flavour in the steam.

NOTE.—Because of the stimulant, young people should not drink tea or coffee.

COFFEE

1. Description.—The beans, or seeds, of coffee also contain tannin as well as a stimulant and flavour. This beverage is more expensive than tea, since a much

larger amount must be used for one cup of liquid. After the beans are broken by grinding, the air causes the flavour to deteriorate, so that the house-keeper should grind the beans as required, or buy in small quantities and keep in tightly covered cans.

2. Method of cooking.—Coffee may be cooked in different ways, according to the size of the pieces into which the roasted beans are broken. These pieces are much harder than the leaves of tea, hence coffee may be given a higher temperature and a longer time in cooking than tea. Small pieces of beans are apt to float in the liquid, making it cloudy; this may be overcome by the use of egg-white or by careful handling.

Coarsely ground coffee must be boiled gently. Finely ground coffee may be boiled gently or steeped. Very finely ground, or powdered coffee should be steeped or filtered with boiling water.

COCOA

1. Description.—This contains a stimulant, but differs from tea and coffee in being nutritious. It makes a desirable drink for children.
2. Method of cooking.—Cocoa contains starch and should be simmered or gently boiled.

CHOCOLATE

This substance is the same as cocoa, except that it contains a much larger amount of fat.

TABLE SETTING

The serving of food is incidentally a necessary part of nearly every lesson in cookery, as the pupils usually eat what they prepare. In regular class work the bare work table is used, and each pupil prepares a place for herself only. The dishes soiled during the lesson should be placed on the section covered with metal or glass at the back of the table, and the front, or wooden part, cleared to be used as a dining table. The teacher should insist on this part being clean and neatly arranged. The few dishes used should be the most suitable selected from the individual equipments, and they should be as carefully placed as for a meal. From the very first, the pupils should be trained to habits of neatness in setting the table, and in serving the food; and, what is most important, they should be trained to eat in a refined manner. Lack of time is sometimes given as an excuse for neglecting this training in the usual cookery lessons; but if the teacher insists upon neatness in work and good table manners, the pupils will soon learn to comply without loss of time.

Laying a table may be formally taught at any stage of the work of Form III, but it is most suitable after the class is capable of preparing the food for a simple home meal. The topics of the lesson may be presented as follows:

PREPARATION

1. See that the dining-room is well aired and in order.
2. See that the linen is clean and carefully laundered.
3. See that the glass, silver, and steel are polished.
4. Decide on the number to be served.

ARRANGEMENT

1. Place a silence cloth of felt, woollen, or thick cotton:
 - (1) To prevent the dishes from making a noise
 - (2) To give the table a better appearance
 - (3) To preserve the table top.
2. Lay the cloth, placing the centre of the cloth in the centre of the table and spreading it smoothly, having its folds parallel with the edges of the table.
3. Arrange a centre-piece, using a vase or basket of flowers, a small plant or a dish of fruit.
4. Put a plate at each person's place and lay the cutlery and silver beside it about one inch from the edge of the table, in the order of use, those used first on the outside, or farthest from the plate. At dinner these plates are usually placed before the one who serves.
 - (1) Place the knives at the right side, with the sharp edges toward the plate.
 - (2) Place the forks at the left side, with the tines up.
 - (3) Place the soup spoons at the right of the knife, bowl up.
 - (4) Place the dessert spoons in front of the plates, the handle to the right, the bowl up.
 - (5) Place the dessert forks with the other forks, or in front of the plates with the dessert spoons.
5. Place the water glasses at the end of the knife blades, top up.
6. Place the bread and butter plates at the left of the forks. (These are not necessary at dinner.)
7. Place the napkins at the left, neatly folded; discourage fancy folding.



Table laid for a home dinner

8. Place the salt and pepper so that they are convenient to every one.
9. Place the dishes that are to be served at table directly in front of the one who is to serve them.
10. Place the carving set in front of the host, and the tablespoons as on page 89, or where food is to be served.
11. Place a chair for each person.

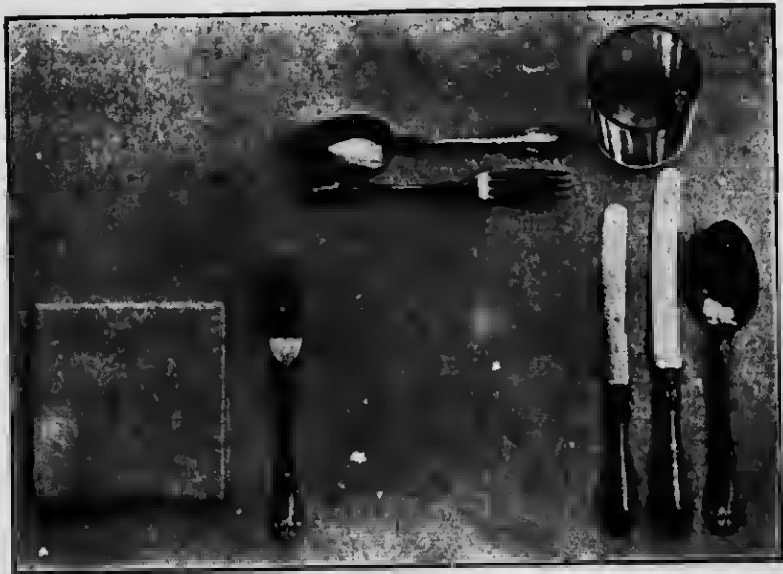

Individual section of table laid for dinner

TABLE MANNERS

In Form III, the children are too young to serve at table, so the lesson on Preparing and Serving Meals, page 136, has been reserved for the work of Form IV, Junior Grade. The class should, however, be carefully trained in table manners from the first. In their usual class work this will be incidentally taught. A regular lesson should include the following:

RULES FOR CORRECT TABLE MANNERS

These are based upon the accepted customs of well-bred people, and have in view the convenience and comfort of all who are at the table.

They may be stated as follows :

1. Stand behind the seat assigned you.
2. Wait until the hostess is seated, before taking a seat.
3. Sit naturally erect, without any support from the elbows, placing the feet on the floor.
4. Do not begin to eat until others are served.
5. Eat and drink quietly, taking small mouthfuls; keep the mouth closed while eating.
6. Do not drink with food in the mouth.
7. Do not talk with food in the mouth.
8. Use a fork preferably, whenever it will serve the purpose; and never put a knife into the mouth.
9. Take soup from the side of the spoon.
10. Wipe the mouth before drinking from a glass.
11. Be attentive to the needs of others.
12. If it be necessary to leave the table, ask the hostess to excuse you.
13. If a guest for one meal only, leave the napkin unfolded beside the plate.
14. Never use a toothpick at the table, or in any company.
15. Wait for the hostess to rise, then stand, and replace the chair in position.

CHAPTER VI

FORM IV: JUNIOR GRADE

THE KITCHEN

AT THE beginning of the year's work in Form IV, several lessons should be spent in reviewing the methods of cooking and cleaning taught in the previous year. This may be done by reviewing former recipes and by using new ones which require a knowledge of these methods. As the pupils work, they should be closely observed, and, without the teacher giving undue assistance, their weak points should be carefully strengthened. The length of time spent on the review will vary according to the ability of the class. This can be plainly judged by their habits of work. The new recipes given them should be such as they are likely to use at home, so as to encourage home practice. These recipes will also enlarge their collection in their special recipe books. Some of the following may be useful: creamed potatoes, potato omelet, stuffed potatoes, stuffed onions, corn oysters, baked tomatoes, spaghetti with tomato sauce, macaroni and cheese, scalloped apples, plain rice pudding, ginger pudding, sago pudding, tapioca cream.

THE KITCHEN FIRE

Up to this time the pupils have been allowed to manage their individual table stoves or a gas range. They should now be taught to understand and to use an ordinary coal or wood range. Two lessons will be necessary for this purpose. After each lesson has been taught, the remainder

of the period should be spent in some kind of practical work which can be accomplished in the time. Some cookery which requires only a few minutes may be reviewed, such as tea, cocoa, coffee, toast, bacon, apple sauce; drawers and cupboards may be cleaned; silver and steel may be polished; designs for wall-paper, dishes, curtains, and dress materials may be drawn; household accounts may be computed; sewing may be finished.

LESSON I

REQUIREMENTS OF A KITCHEN FIRE

In introducing a lesson on the kitchen fire, ask the pupils to imagine that they have built a new house, which the workmen have just vacated. Before they can move in it must be cleaned. What kind of water is best for cleaning? Hot water. What is necessary to provide hot water? A fire.

Find out from the pupils and then write on the black-board what is necessary for a fire. What is the first requisite? Something to burn. What do we call such a substance? *Fuel*. Where shall we put the fuel? In a *stove*. Why is a stove necessary? To confine the fire.

Using a candle as fuel and a lamp chimney as a stove, light the candle and place it in the chimney. It burns only a short time and then dies out. Why? Because the oxygen of the air in the chimney is all exhausted. Then what is another requisite for a fire? *Oxygen*.

Imagine the room to be a stove and the chairs, books, tables, etc., to be fuel. The air in the room also contains much oxygen, so that in this room we have three requisites for a fire. It is very fortunate for us that something else is needed. We shall try to find out what it is.

Watch while I hold these strips of paper over this lighted gas stove high enough to be out of reach of the flame. What happened to them? They burst into a flame. What did the paper that I held receive that it did not get when it was lying on the table? Heat. We shall try a match in the same way, also some thin shavings. They also burn when they receive heat from the fire. Then what is another requisite for a fire? *Heat*. Name all of the requisites for a kitchen fire. *Fuel, stove, oxygen, and heat.*

NOTE.—Just here it is a good thing to impress the care that is necessary in regard to gasoline, coal-oil, benzine, etc., or any substance that burns at a low temperature. Bring out the fact very clearly that it is the heat that makes fuel burn, that a flame is not necessary.

HEAT

Experiments to show on what the amount of heat required depends:

1. Heat together two strips of paper of the same size but of different thicknesses and observe which burns first.
2. Heat together a strip of very thin paper and a match which is much thicker than the paper, and observe which burns first.
3. Rub a match vigorously on some surface and observe the result.

Conclusions.—1. The amount of heat required to make fuel burn depends on:

- (1) The thickness of the fuel.
 - (2) The substance composing the fuel.
2. Some substances burn at a very low temperature.

NOTE.—This will explain the order of laying the fuel for a fire and the use of a match in lighting it.

OXYGEN

Experiments to show the means of obtaining oxygen :

1. Light a candle, set the lamp chimney over it and observe the result.
2. Raise the chimney by supporting it on two small pieces of wood. Note the result.
3. Cover the raised chimney with a piece of cardboard. Note the result.

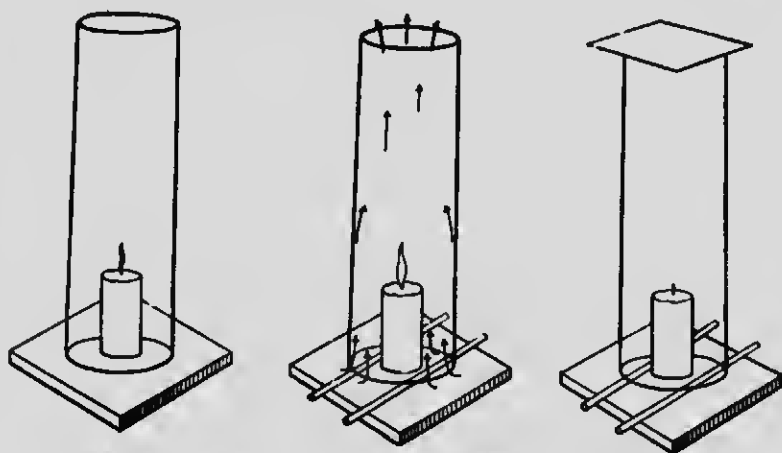

Experiments to show the necessity for oxygen

Conclusions.—1. A fresh supply of oxygen is constantly required.

2. Two openings are required to ensure a constant supply of oxygen, one below the fuel and one above it.
3. Oxygen is obtained from the surrounding air.
4. The passage of air through these openings creates a draught.

It will be necessary next to lead the class to see that the supply of oxygen can be controlled:

1. By the relation of the openings:
 - (1) Openings directly opposite each other cause a rapid circulation of air or a "direct draught".
 - (2) Indirect openings cause a slower circulation of air or an "indirect draught".
2. By a cross current of air which tends to check the draught.

FUELS

A discussion of the fuels may next be taken. With pupils of Form IV it will not be wise to go into too many details regarding these. Besides the classification of the commonest ones, they may be compared from the stand-points of cost, and of the time and labour required in their use.

Classes of Fuels:

Liquid—coal-oil, gasoline, alcohol

Solid—coal (coke), wood (charcoal)

Gaseous—natural gas, coal gas.

NOTE.—Electricity is a means of producing heat, but cannot be called a fuel.

THE KITCHEN STOVE

LESSON II

In developing the construction of a practical coal or wood range, it is a good idea to use the black-board and make a rough drawing to illustrate the details, as they are

given by the pupils. These details should be evolved from the knowledge gained in the preceding lessons, and the drawing should not be an illustration of any particular stove.

After the best practical stove, according to the pupils' ideas, has been thought out and represented on the black-board, they should examine and criticise the school range and the stoves at home. They are then ready to be given the responsibility of managing any ordinary range.

The following are the necessary details to be considered regarding a kitchen stove:

Material.—(1) Iron, (2) steel

Shape.—Rectangular.

Compartments.—(1) Fire-box, (2) ash-box, (3) oven, (4) passage for hot air, (5) other compartments if desired, such as water tank, warming closet, etc.

Dampers.—(1) Front damper—below the fuel, to control the entrance of oxygen to the fuel. (2) Oven damper—above the fuel at the entrance to the pipe, to control the heat for the oven, and also to control the draught. (3) Check damper—at the front of the stove above the fuel, to admit a cross current of air to check the draught.

Management of the stove.—(1) Lighting the fire, (2) heating the oven, (3) arranging for over night, (4) cleaning and care.

NOTE.—Openings below the level of the fire increase the draught, and those above the level check it.

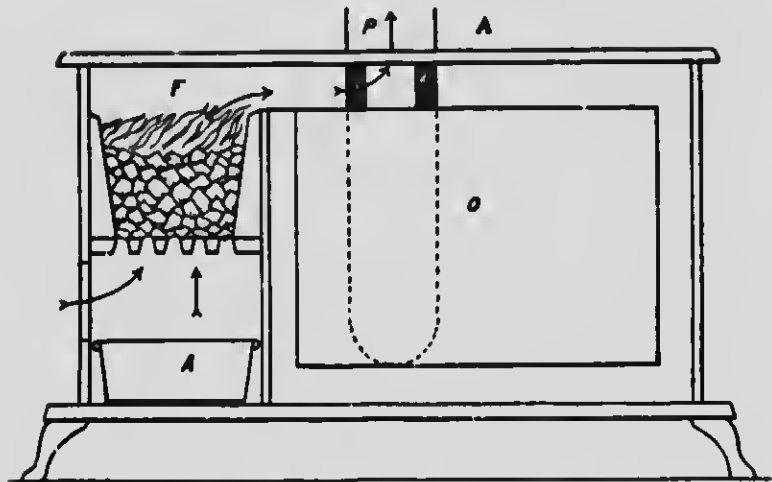

A kitchen coal or wood range, showing, (a) oven damper open

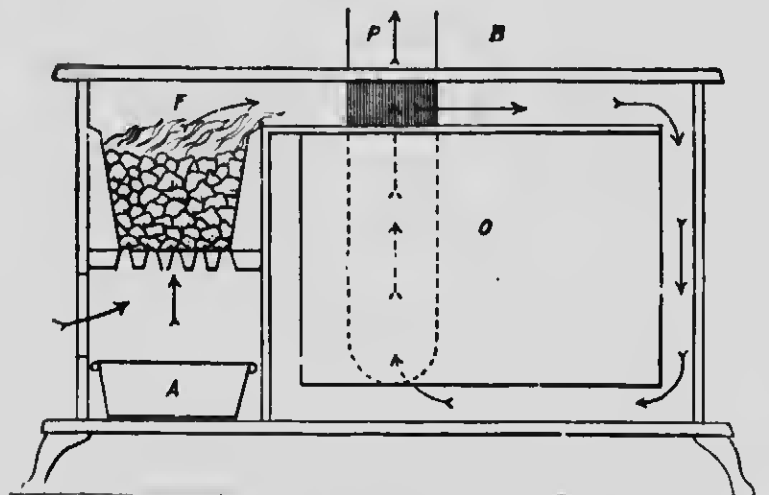

A kitchen coal or wood range, showing, (b) oven damper closed

THE FIRELESS COOKER

Throughout the training given in Household Management, the teacher should emphasize the value of labour-saving devices and aids in the home. How to economize time and energy should be a prominent feature of every practical lesson. If time permit, a lesson may be taken to consider specially such aids as are readily procurable, together with their average cost. In this lesson the fireless cooker is considered.



A fireless cooker

The principles of the fireless cooker are based on a knowledge of the laws governing the conduction and radiation of heat. For this reason, an elementary science lesson relating to these laws should precede this lesson. Such a science lesson is part of the regular grade work of Form IV, so if a specialist teaches the Household Management of that grade, she and the regular teacher should arrange to co-ordinate their lessons.

PRINCIPLES OF THE FIRELESS COOKER

1. It furnishes no heat, but conserves the heat which is in the food when it is put into the cooker.
2. It conserves the heat in the food, by surrounding it with substances which are poor conductors of heat.
3. Extra heat may be given the food, after it is put in the cooker, by placing heated stone plates above and below the dish that contains the food. The stone used for this purpose must be a good absorbent of heat.

REASONS FOR THE USE OF THE FIRELESS COOKER

1. It saves fuel and is therefore economical.
2. It saves time, because it requires no watching.
3. It conserves the flavour of the food.
4. It obviates all danger of burning the food.
5. It does not heat the room.

WAYS OF USING THE FIRELESS COOKER

1. Food cooked in liquid:

In all cookers where stone plates are not used, only such foods as are cooked in liquids can be prepared. Examples of foods cooked in this way are, meat soup, beef-tea, meat stews, vegetables, fruit, porridge, cereal, puddings, etc.

The prepared food is put into one of the food receptacles belonging to the cooker and is placed over a fire, until it has boiled for a few minutes. The cover is then tightly adjusted, and the dish quickly locked in the cooker, to conserve the heat that the food and liquid have absorbed.

2. Food cooked in dry heat by the use of stone plates:

In this method the food is cold when it is placed in the cooker, and all the heat is supplied by stone plates

placed above and below the utensil containing the food. These plates are heated for about twenty minutes over a fire, before they are used in the cooker.

Examples of food cooked in this way are, roasts of meat; baked fruit, such as apples; baked vegetables, such as potatoes or beans; cakes, such as plain cake or fruit cake; quick bread, such as corn-bread and biscuits.

3. Food cooked in liquid, aided by the heat of one stone plate:

In cases where the original heat absorbed by the food is not sufficient to complete the cooking as desired, a heated stone plate may be placed in the cooker below the utensil containing the hot food. The stone may be necessary for one of the following reasons—

- (1) Because the amount of food put into the cooker is too small to contain much heat. It is always better to have the food nearly fill the dish.
- (2) Because the time required is so long that the heat of the food and liquid becomes exhausted before the cooking is completed.
- (3) Because it is desirable to finish the cooking in less time.

A HOME-MADE FIRELESS COOKER

Use a large wooden box or a small trunk with a close-fitting cover. Make it as air-tight as possible by pasting thick paper all over the inside.

Pack it level with clean sawdust or excelsior (the latter preferably), until just enough height is left to set in a covered granite pail, which is to be used for holding the

food. Place the pail in the centre, so that its top edge is just about half an inch below the top of the box. Then pack in more excelsior very tightly around the pail, until level with it. This will shape the "nest" for the pail.



A home-made fireless cooker

Make a thick cushion, or mat, of excelsior to fit in the space between the level of the excelsior and the inside of the cover. Cover the cushion with cheesecloth or denim to keep it intact.

NOTE.—Only food cooked in a liquid can be prepared in a home-made cooker.

CHAPTER VII

FORM IV: JUNIOR GRADE (Continued)

STUDY OF FOOD

THE PUPILS have been working with some of the well-known foods in all of their recipes and should have a fair knowledge of how to prepare them in simple ways for the table. It is now time for them to learn what these foods contain for the use of their bodies. Much of this part of the work can be taught in rooms without special equipment. An earnest teacher, with a few articles from home, can make the study interesting and valuable.

A series of lessons will be necessary for this purpose. The amount of work to be taken at one time is suggested, but this should be judged by the teacher. As in other lessons on theory, the remaining time of the lesson period should be used in practical work. Suggestions for such practical work are given under the lesson on "The Kitchen Fire", page 92.

Practice lessons, to give variety and sustain interest, should be interspersed between these lessons as desired.

LESSON I

USES OF FOOD

The lesson may be introduced by asking the class to think in what way the body of a healthy baby, who is fed regularly, will have changed at the end of six months. It will be larger; it will have more flesh, more bone, more hair, etc. We want to get a name that will apply to any

part of the body. No matter which part we examine through a microscope we find the same fine and beautiful texture, and to this we give a name similar to that given to fine, thin paper. We call it *tissue*—hair tissue, bone tissue, flesh tissue.

What has food done to the baby's tissues? It has enlarged its tissues; the child has grown larger. To the enlargement, or growth, of the tissues, we may apply the term, *build*, suggested by the building of a house. Then what may we say food does for the tissues of the body? We may say that *food builds the tissues of the body*.

Think of some persons who have taken food every day, and yet as long as you have known them they have not increased in size. What has food done for their tissues? The class must be told that the tissues of our bodies wear out through use, and that food has furnished the material to replace the worn-out parts. What do we say we are doing to clothes when we replace the worn parts? We are mending or repairing them. What does food do for our worn-out tissues? *Food repairs the tissues of the body*.

Do not think any more about the tissues of the body. Suppose you had not been able to get any food for several days. In what way would you be different from what you are now? You would not be as strong. Food gives strength or energy by being burned inside the body. There is a fire burning in our bodies all the time we are alive, the fuel being food. What do we require from the fire in our homes? We require heat. The fires in our bodies give us heat also. Any fire gives off both heat and energy. State another use of food to the body. *Food produces heat and energy in the body*.

But food does more for the body; it contains substances to keep our bodies in order. Suppose the clock gets

out of order and does not keep good time, what does the watchmaker do to it? He regulates it. That is what certain kinds of food do for us. What then is another use of food? *Food regulates the body.*

Name the uses of food to the body.

1. It builds the tissues.
2. It repairs the tissues.
3. It produces heat and energy.
4. It regulates the body.

How then can we judge if a substance be a food? By deciding that it performs one of these duties in the body.

LESSON II

NECESSARY SUBSTANCES IN FOOD

The names of the substances in food which supply the material for the different uses of the body should be taken next.

1. *For building and repairing.*—(1) Mineral matter—used largely in hard tissues. (2) Nitrogenous matter, or protein—used largely for flesh. (3) Water—used in all tissues.
2. *For fuel.*—Carbonaceous matter (starch, sugar, fat).
3. *For regulating.*—Mineral matter, water.

NOTE.—The teacher should call attention to the fact that few foods contain all these substances, some have nearly all, some have only one, some two or more. In order to get all, we must eat a variety of foods. The class is now ready to consider the well-known foods, in order to find out which of these necessary substances each food contains, and to obtain a general idea of their comparative food values.

SOURCES OF FOOD

All nature supplies us with food. The three great divisions of nature are animal, vegetable, and mineral, and from each we obtain food, though most largely from the animal and vegetable kingdoms.

Animal food is some part of an animal's body or some product of an animal: examples—meat or fish, milk, eggs.

Vegetable food is some part of a plant: examples—vegetables, fruit, seeds.

Mineral food is some constituent of the earth's crust used as food. This mineral food is obtained by drinking water which in coursing through the earth has absorbed certain minerals, by eating plants which have absorbed the minerals from the soil, or by eating animal food which was built from plant food.

This preliminary survey of the sources of all our food gives the pupils a basis for classifying the foods with which they are familiar. They may be given exercises in doing this, and will not only find them interesting, but most useful as nature study.

STUDY OF THE COMMON FOODS

In beginning the analysis of the common foods, it must be remembered that the pupils have no knowledge of chemistry, and that what is found in each food must be discovered through the senses (seeing, smelling, tasting, feeling), or through a process of reasoning.

The pupils should also feel quite sure of what they are setting out to do; they are going to examine some particular, well-known food, to find which of the necessary

food substances it contains. The food substances for which they are looking are water, mineral matter, nitrogenous matter, and carbonaceous matter (sugar, starch, fat).

It is better to provide each pupil with a sample of the food to be studied, but where conditions make this difficult, the one used by the teacher will suffice.

STUDY OF MILK

LESSON I

COMPOSITION

Milk is the best food to examine first, because it contains all the food elements except starch and because these can be easily found.

The pupils may each be asked to bring a half cup of milk from home. It may be allowed to stand in glasses while other work is taken.

When ready for the lesson, ask the pupils to look at the contents of the glass, and they will observe a difference of colour where the cream has risen. Nature itself has divided the milk into two parts. Pour off the top part and feel it. It feels greasy. Butter is made from this part. We have found *fat*—a carbonaceous food.

Move the milk around in the glass and let the pupils see that it is a liquid. Tell them that all liquid in a natural food is mostly water. We have, therefore, another food substance—*water*, a builder and regulator.

Let the pupils compare a glass of water with a glass of skimmed milk, and they see that something is dissolved in the water of the milk, giving it the white colour. Show

them a glass of sour milk, where the white substance is separate from the water. Get the names curd and whey. Tell them how the cheesemaker separates sweet milk into curd and whey. If advisable, let them do it, but in any case show them some sweet milk separated by rennet. Examine the sweet whey. It tastes sweet, denoting the presence of *sugar*—another carbonaceous food.

Notice the greenish-yellow colour. Recall this same colour in water in which potatoes, cabbage, or other vegetables have been cooked. Tell the pupils that this colour is given by *mineral matter* being dissolved in the water.

There is still the curd of milk to examine. The use of the senses does not allow us to definitely decide what food substance the curd is. Tell the pupils it is protein, or find the name by a process of reasoning, thus: Recall the fact that babies live for several months on milk alone and during that time build all tissues of the body. Milk, therefore, must contain all tissue-building substances. Review the food substances which are necessary to build all body tissues—mineral matter, protein, and water. We have found the mineral matter and water in milk, but not the protein. Since curd is the only remaining part of milk, it must be largely protein.

Tell the pupils that the scum which comes on the top of milk, when it is boiled, is another kind of protein of which there is a small amount in solution in milk.

Lead the pupils to see that if starch were present, it would be in a raw form, and in this form is indigestible.

LESSON II

FOOD VALUE

The analysis of milk gives a key to the food value of milk and each of its by-products (cream, butter, buttermilk, sour milk, skim milk, curd, whey, cheese, junket). These may now be briefly discussed as to composition, food value, and cost.

CARE

Milk readily absorbs odours, bacteria, etc., and should be kept in covered, sterilized dishes in a pure, cool atmosphere.

EFFECT OF HEAT

Experiments should be made to show the effect of simmering and boiling temperatures. To save time, a different experiment may be given to each pupil, and the results reported.

1. Simmer sweet milk and note the flavour.
2. Boil sweet milk and note the flavour.
3. Simmer the curd of milk. Examine its texture.
4. Boil the curd of milk. Examine its texture and compare it with the simmered curd.
5. Boil skim milk and note the scum.
6. Simmer skim milk and note the absence of scum.

NOTE.—From the above experiments deduce the effect of heat on protein.

Practice lessons may now be given in preparing simple dishes in which milk is the main ingredient, or, at least, recipes may be given for these to be made at home. The following would be suitable: cream sauce, cream soups, custard, junket, cottage cheese, albuminized milk.

STUDY OF EGGS

LESSON I

PARTS

- (1) Shell, (2) thick membrane, (3) white, (4) thin membrane, (5) yolk.

These parts are easily seen. Attention should be called to the pores in the shell, and it should be explained that these allow the entrance of bacteria which spoil the egg. Any means of closing these pores helps to preserve the egg.

METHODS OF PRESERVING

Cover the holes in the shell as follows:

1. Pack in salt, bran, sawdust, brine, or water-glass.
2. Coat the shells with fat or wax.
3. Wrap the eggs in paper.

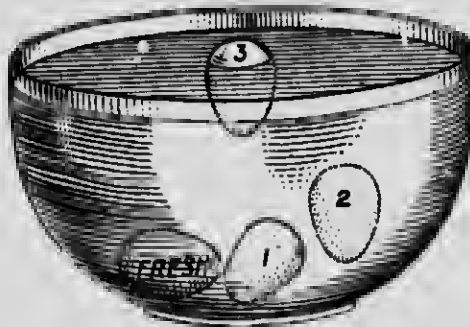

Testing eggs by floating:
(1) slightly stale, (2) stale, (3) very stale

TESTS

1. In the shell:

After an egg is laid, the liquid which it contains begins to evaporate through the pores of the shell and, as this continues, a noticeable space is left inside.

- (1) Shake the egg, holding it near the ear. If the contents rattle, it is somewhat stale.
 - (2) Drop the egg in cold water. If it sinks, it is fresh.
 - (3) Hold the egg between your eye and the light. If clear, it is fresh.
 - (4) A rough appearance of the shell denotes freshness.
2. Out of the shell:

White—this should be clear and cling to the yolk.

Yolk—this should round up like a ball.

CARE

1. If eggs are to be used in the near future, they should be washed and put in a pure, cool atmosphere. The lower shelf of the refrigerator is best, as odours rise, and eggs readily absorb these.

2. If eggs are to be preserved, they should not be washed unless their condition compels it, as washing removes the natural covering of the pores. They should be stored in a clean, cool place, and packed as soon as possible.

LESSON II

COMPOSITION

It is wiser to develop the food substances in an egg by reasoning, rather than by examining the different parts. The shell is not used for food, so it is the contents that should be studied. The class should be guided in the following sequence of thought:

1. An egg is designed by nature to become a chicken, so it must contain all of the substances necessary to build a chicken.

2. A chicken is an animal, and all animal bodies are made of the same substances. These we have seen to be mineral matter, protein, and water.
3. An egg therefore contains these three substances.
4. An egg must also contain three weeks' food for the chicken, therefore must have fuel food as well. This fuel food is found in the yolk, in the form of fat.
5. The yolk therefore contains water, mineral matter, protein, and fat.
6. The white contains water, mineral matter, and protein.

EFFECT OF HEAT ON EGGS

The following experiments will show the effect on both yolk and white of the usual methods of applying heat to eggs:

1. Boil an egg for three minutes and note the effect.
2. Boil an egg for twenty minutes and note the effect.
3. Put an egg in boiling water, remove from the fire, and let it stand covered from eight to ten minutes.
4. Fry an egg and note the effect.

NOTE.—The eggs may be put to boil and simmer at the beginning of the lesson, and pupils designated to take them from the heat at proper times. The eggs will then be ready to examine when required.

CONCLUSIONS

1. Boiling an egg for three minutes does not allow time for the heat to reach the yolk. The white is hard and tough just next the shell, but soft and liquid as it approaches the yolk.

2. Boiling an egg for twenty minutes hardens and toughens the white, so that it all becomes hard to dissolve or digest. It also gives the heat time to reach the centre and hardens the yolk, but does not toughen it or make it hard to dissolve or digest.
3. Allowing the egg to stand in the hot water coagulates the white to a jelly-like consistency without toughening it; it also cooks the yolk.

LESSONS III, IV, ETC.

USES OF EGGS

To give practice in preparing eggs and to show their special uses the following dishes would be suitable:

1. White:

- For food—poached eggs on toast, simmered eggs
- For cohesive (sticky) property—potato balls, fish balls
- For clearing liquids—coffee
- For holding air—foamy omelet
- For decoration—hard-boiled eggs cut in fancy shapes for garnishing, meringue on lemon pudding, etc.

2. Yolk:

- For food—egg-nog, scrambled eggs
- For thickening liquids—custard, salad dressing, lemon pudding
- For colouring foods—tapioca cream
- For decoration—hard boiled and grated over salads.

STUDY OF VEGETABLE FOOD

Before beginning this part of the work, it would be most helpful if the class had one or two nature study lessons on the structure and organs of plants. With the pupils in possession of some knowledge thus acquired, the Household Management teacher has only to lead up to ideas of the preparation and value of these parts as food. These ideas should, as far as possible, follow in such a natural order that the pupils may even anticipate the sequence.

The outline may be as follows:

LESSON I

SOURCE

All vegetable food is obtained from plants; it is some part of a plant used as food.

PARTS OF PLANTS USED AS FOOD

1. Root—carrot, radish
2. Tuber—potato, artichoke
3. Bulb—onion
4. Stem—rhubarb, asparagus
5. Leaf—spinach, cabbage
6. Flower—cauliflower
7. Fruit—apple, orange
8. Seed—(1) Of trees (nuts)—beechnut, almond
(2) Of grasses (cereals)—wheat, corn, rice
(3) Of vines (legumes)—peas, beans, lentils.

In asking for examples of the different parts, there will be more interest and value if the questions correlate other

subjects, for instance: For what fruit is Canada noted? What fruit does she import? Name a nut the squirrels gather.

LESSON II

COMPOSITION OF ANY PART OF A PLANT

From the foregoing, the pupils may infer that there are eight different foods to study. They should be led to see that in reality there is only one, as all parts of plants are, generally speaking, the same in structure. Referring to the animal body, they will know that a bone from the foot is of much the same structure as one from the face; that a piece of flesh from the leg is the same as a piece from any other part of the body. In the same way, if we study one part of a plant, it will be a type of all parts. In general the structure is as follows:

1. A framework, in cellular form, made of a substance called *cellulose*.
2. Material filling the cells:
 - (1) A juice in the cells of all parts of plants except seeds
 - (2) A solid in the cells of seeds.

To show the framework, some vegetable food having a white colour should be chosen, such as potato, parsnip, or apple.

It must be explained that all plants are made of a framework of numerous cells, something like a honey-comb. The cells in plants are of many different shapes, according to the plant, or the part of the plant, in which they are found. They are usually so small that they cannot be distinguished without a microscope; but occasion-

ally they are large enough to be seen without one. Pass sections of orange or lemon, where the cells are visible. Make a drawing on the black-board of the cellular formation of a potato. Lead the class to understand that, in every case, the cell walls must be broken to get out the cell contents. To illustrate this, they may use potatoes, and break the cell walls by grating the potatoes. After they have broken up the framework, the cell contents

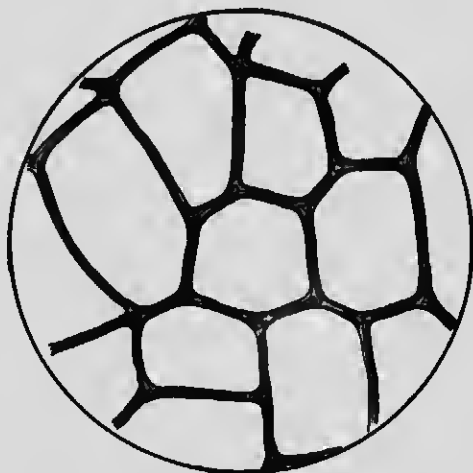

Cellular structure of a potato

should be strained through cheesecloth into a glass. They have now two parts to examine—cell walls and cell contents.

Wash the framework to free it of any cell juice and study it first. Give its name, and note its colour and texture. Compare the framework of potatoes, strawberries, lettuce, trees, etc. Tell the class that in some cases part of the cellulose is so fibrous that it is used to make thread, cloth, or twine; for instance, *flax* and *hemp*.

Cellulose is most difficult to dissolve, so that practically little of it is digested. It serves a mechanical purpose in the digestive tract by helping to fill the organs and dilute the real food. If fibrous, it acts as an irritant and overcomes sluggishness of the intestines known as constipation. The outer coats of cereals are an example of coarse cellulose, as used in brown bread and some kinds of porridge.

Examine next the juice which was contained in the cells of the potato. The liquid shows much water; the colour indicates mineral matter in solution; the odour suggests a flavour; the white sediment is starch.

COMPOSITION OF POTATO JUICE

Water, mineral matter, flavouring matter, starch.

Draw attention to the fact that the potato is the part of the plant which acts as a storehouse. In such parts, starch is always found as the stored form of sugar; but, in parts which are not storehouses, sugar will be found in its stead. In rare cases both are found, as in the parsnip.

NOTE.—This is a good time to impress the fact that plants are the source of starch for manufacturing purposes. In England, potatoes are largely used; in Canada, corn. It will be interesting to state that the early settlers obtained their starch for laundry purposes at home from potatoes, by chopping or grinding them.

The insolubility of starch in cold liquids may be effectively reviewed at this part of the lesson. The starch has been lying in the water of the potato cells for several months, yet has not dissolved. Let two or three of the class gradually heat the potato juice with its starch sediment, stirring all the time to distribute the sediment evenly.

They will find that a little less than boiling temperature dissolves the starch. This will show them that heat is necessary for the solution of starch, and a heat much greater than that in the body, hence raw starch is indigestible. Recall the milk lesson and the uselessness of starch as a component of milk, unless the milk be cooked.

Squeeze the juice from a sour apple or lemon, and note the taste. Explain that all fruit juices contain more or less acid. The effects of this acid in the body are similar to those of mineral matter.

Protein is also found in plant juices; but in such small quantities that it may be disregarded as a source of food supply.

GENERAL COMPOSITION OF PLANT JUICE

Water; mineral matter; flavouring matter; starch or sugar, or both; acid (in fruit juice).

LESSON III

COMPOSITION OF SOLID MATERIAL IN CELLS OF SEEDS

This part of the lesson may be developed as follows:

1. Seeds contain the building material for new plants, as well as their food for a short time.
2. Plants and animals require much the same material to build and feed them.
3. Animals require water, mineral matter, protein, sugar, starch, and fat.
4. Plants require the same; but the seed being a storehouse part of the plant, it will not have sugar, and water has to be supplied when the new plant is to be formed.

5. Seeds contain, therefore, mineral matter, protein, starch, and fat.

NOTE 1.—Seeds will grow in water until their stored food is used: they must then be planted in soil, to get further nourishment.

NOTE 2.—The two fuel foods, starch and fat, are not found together in abundance in seeds; one or the other will be much in excess. For instance, in walnuts there is a great deal of fat, while in peas and beans there is scarcely a trace of fat, but the starch is abundant.

COMPARATIVE FOOD VALUE OF DIFFERENT PARTS OF PLANTS

Only a very general idea of this should be attempted. The food value of any part of a plant can be roughly estimated by considering the office of that particular part in plant structure. Nature study will assist in this. The root collects the food to send it to the parts above; the stem is a hallway through which the food is carried in a more diluted form. The leaves serve the purpose of lungs and will not contain much food, though they naturally have a good deal of flavour; parsley, sage, and tea are examples of this. The fruit is a house to protect the seeds, and is made most attractive and delicious, so that animals will be tempted to eat this part, and thus assist in the dispersal of the seeds. The fruit has comparatively little food value as building material. The seed contains the stored material to build new plants, and therefore is the most nutritive part of all. It is the only part of the plant which contains an appreciable supply of building food, that is, which can take the place of eggs or meat in the diet. Baked beans are sometimes called "nuggets of nourishment" or "the poor man's beef".

LESSON IV

After discussing the food value of the different parts in this broad way, the pupils may be asked to consider the plant foods used in their diet and to compare their nutritive value.

The facts concerning these may be summed up as follows:

1. Green vegetables:

These generally contain much water, hardly any protein or fat, and a small amount of sugar. They are valuable mainly for their mineral matter and cellulose.

2. Root vegetables and tubers:

These are more nutritious than green vegetables, because they contain much more sugar and starch.

3. Ripe seeds (cereals, legumes, and nuts):

These are highly nutritious, because of the large amount of protein and building mineral matter they contain, and also the amount of fuel food.

DRIED VEGETABLES AND FRUIT

It is important that the value of these be pointed out. Dried foods contain all of the constituents of fresh food excepting water and a little flavour lost in evaporation, yet they are often much cheaper. Attention should be directed to the best means of restoring the water and, if necessary, of giving an additional flavour by the use of cloves, cinnamon, etc.

Canning is a better means of preserving food for export or for use when out of season, but where the expense prohibits this method, drying is a good substitute. In districts where fruit and vegetables cannot be grown or in seasons when they cannot be obtained fresh, the dried forms are cheap and have excellent food value.

THE COOKING OF VEGETABLE FOOD

As vegetable food is eaten both raw and cooked, the pupils should be asked to decide when cooking is necessary and what they wish it to accomplish.

There are only two substances in vegetable food which will require cooking, and these are:

1. Cellulose, if it be hard or tough
2. Starch, if it be present.

The pupils have found in their experiment with the potato water, that starch cooks quickly, hence the time of cooking will depend altogether on the texture of the cellulose. When the cellulose is softened at the centre, the last part which the heat reaches, the vegetable or fruit will be cooked.

If the food is cooked in water by boiling or simmering, much of the substance will pass into the cooking water. As the cell walls become softened, they allow the cell contents to partially pass out and the cooking water to pass in to fill the space. If the food is long in cooking, the water may have more value than the vegetable, and it should not be thrown away. It may be used in two ways—as a basis for a sauce or a soup.

GENERAL RULES FOR COOKING VEGETABLES

NOTE.—As the principles in the general rules have been taught, these rules may be dictated to the class.

PREPARATION

1. Wash, pare, peel, or scrape the vegetable, and cut it into convenient sizes.
2. Unless green vegetables are freshly gathered, soak them in cold water for an hour before cooking.
3. Soak dried vegetables at least twelve hours.

COOKING

1. Put all vegetables on to cook in boiling water, except dried vegetables, which should be put on in cold water.
2. Strong-smelling vegetables should be cooked at simmering point, the others may boil gently.
3. For vegetables that grow above ground (including onions), salt the water (one tsp. to a quart).
4. For underground vegetables, do not salt the water.

VEGETABLE RECIPE

Prepare and cook the vegetables until tender, according to the rules given above. Drain off and measure the vegetable water. For each $\frac{1}{2}$ cup of vegetable, take $\frac{1}{4}$ cup of the water and make into a sauce. Re-heat the vegetable in the sauce and serve in a hot dish.

NOTE 1.—For potatoes and tomatoes do not follow this recipe.

NOTE 2.—The sauce is made by thickening each cup of vegetable water with two tablespoonfuls of flour, and seasoning as desired with salt, pepper, and butter.

NOTE 3.—Another method of saving and using the valuable vegetable water is to make it into a soup.

GENERAL RULES FOR COOKING FRUIT

FRESH FRUIT

1. Stewed.—Put the prepared fruit in a saucepan with enough water to keep it from burning. Cover closely, and stew until tender, stirring often. Add the sugar and let the mixture boil a minute more.
2. Cooked in syrup.—Make a syrup of one part sugar to two or three parts water. Put the prepared fruit in the hot syrup, cover closely, and simmer until tender.

DRIED FRUIT

Wash the fruit thoroughly. Cover with cold water and soak twenty-four hours. Put on to cook in the same water in which it has soaked. Add spices if desired. Cover closely and simmer until tender. Add the sugar and simmer ten minutes longer. Take out the fruit, and, if necessary, boil down the syrup, then pour it over the fruit.

LESSONS V, VI, ETC.

While studying vegetable food, practice will be given in nearly every lesson in the preparation and cooking of vegetables or fruit, but after the completion of this series of lessons, these foods should be prepared and cooked with more intelligence and interest. For this reason, there may be, at the last, one general practical lesson devoted to vegetables and fruit, to review and impress the facts that have been taught. As potatoes, on account of their large amount of starch, require special care, an extra lesson may be given to this vegetable.

In the lesson on potatoes the attention of the class should be directed to the following:

POINTS IN COOKING POTATOES

1. Be sure to soften the cellulose thoroughly.
2. After the potatoes are cooked, get rid of all possible moisture, that they may be white and mealy.
 - (1) If potatoes are cooked in water, drain them thoroughly, remove the cover, and shake over the heat to dry out the starch.
 - (2) If potatoes are baked, break the skins and allow the moisture to escape as steam.
3. When serving mashed potatoes, pile them lightly without smoothing.

USE OF STARCH TO THICKEN LIQUIDS

A lesson on the use of starch for thickening purposes should be given before lessons on the making of a sauce or a soup from the water in which vegetables have been cooked. The necessity of separating the starch grains should be shown by experiments.

EXPERIMENTS IN USING STARCH FOR THICKENING (Any powdered starch may be used)

1. Boil $\frac{1}{4}$ cup of water in a small saucepan. While boiling, stir into it $\frac{1}{2}$ tsp. of cornstarch and let it boil one minute. Observe the result. Break open a lump and examine it.
2. Mix 1 tsp. of cornstarch with 2 tsp. of cold water, and stir into $\frac{1}{4}$ cup of boiling water. Note the result.
3. Mix 1 tsp. of cornstarch with 2 tsp. of sugar and stir into $\frac{1}{4}$ cup of boiling water. Note the result.

4. Mix 1 tsp. of cornstarch with 2 tsp. of melted fat in a small saucepan and stir into it $\frac{1}{4}$ cup of boiling water. Note the result.

CONCLUSIONS BASED ON THE FOREGOING EXPERIMENTS

1. Starch granules must be separated before being used to thicken a liquid:
 - (1) By adding a double quantity of cold liquid
 - (2) By adding a double quantity of sugar
 - (3) By adding a double quantity of melted fat.
2. The liquid which is being thickened must be constantly stirred, to distribute evenly the starch grains until they are cooked.

BASIC RECIPE FOR LIQUIDS THICKENED WITH FLOUR.

	Milk	Flour	Butter
Thin cream sauce	1 cup	1 tbsp.	1 tbsp.
Thick cream sauce . . .	1 cup	2 tbsp.	2 tbsp.

NOTE.—Use thick cream sauce to pour over a food. Use thin cream sauce when solid food substance is mixed with the sauce.

VARIATIONS OF BASIC RECIPE

1. Tomato sauce.—Use strained tomato juice instead of milk.
2. Vegetable sauce.—Use vegetable water in place of the milk.
3. Cheese sauce.—Use $\frac{1}{3}$ to $\frac{1}{2}$ cup of *grated* cheese in 1 cup of thick cream sauce.

CREAM OF VEGETABLE SOUPS

At least one practice lesson should be given on the making of these soups. The value of the vegetable water should be impressed upon the pupils, and it may be pointed out that these soups are an excellent way of using the cooking water and any left-over vegetable.

The difference between tomatoes and other vegetables should be noted. Tomatoes are a fruit and, as such, contain an acid. The acid would curdle milk and must be neutralized by the use of soda, before milk can be added.



Utensils used for cream soups

PRINCIPLES OF CREAM SOUPS

1. The liquid may be all milk, part vegetable water and milk, or all vegetable water.
2. The amount of flour used for thickening depends on the vegetable. Starchy vegetables need only $\frac{1}{2}$ tbsp. to one cup of liquid; non-starchy vegetables need 1 tbsp. to a cup.
3. The ingredients are combined as follows:
 - (1) The liquid is heated and thickened with flour.
 - (2) The seasonings of butter, salt, and pepper are added.

- (3) The vegetable pulp is added in any desired quantity, usually about two tbsp. to one cup of liquid.

A special recipe should be given for cream of tomato soup, so that the proportion of soda may be correct.

NOTE.—If flavours of onion, bay-leaf, parsley, etc., are desired, these should be cooked with the vegetables, so as to be extracted in the vegetable water.

OUTLINE OF LESSONS ON COOKING SEEDS

CEREALS: WHEAT, OATS, CORN, RICE, RYE, BARLEY

1. Forms in which used:

- (1) Whole or cracked grains—rice, cracked wheat, coarse oatmeal, etc.
- (2) Granular—corn meal, cream of wheat, fine oatmeal, etc.
- (3) Rolled or flaked grains—wheat, oats, corn, rice, etc.
- (4) Powdered—wheat flour, rice flour, etc.

2. Cooking cereals for breakfast:

For 1 cup of water use $\frac{1}{4}$ tsp. of salt and the following cereal—

Whole or cracked— $\frac{1}{4}$ cup of cereal

Granular—3 tbsp. of cereal

Rolled or flaked— $\frac{1}{2}$ cup of cereal.

Put salt and water in the inner part of a double boiler, and set directly over the fire. When steaming hot, gradually stir in the dry cereal, and keep stirring until the starch has thickened and boiled. Stir carefully, so as not to break the flakes of rolled cereals. Then set the inner

dish inside the outer part of the double boiler, in which there should be boiling water, and cook from two to four hours.

NOTE 1.—Rice has very tender cellulose and cooks in $\frac{3}{4}$ hr.

NOTE 2.—Rolled or flaked cereals have been steamed an hour or more to soften them for rolling, so require less cooking.

NOTE 3.—Cereals may be cooked for breakfast the day before, but *should not be stirred while being re-heated.*

LEGUMES: PEAS, BEANS, LENTILS

1. Forms in which used:

- (1) Ripe seeds
- (2) Meals—pea meal, etc.

2. Cooking of dried legumes:

- (1) Soak in cold, soft water for twelve hours or more, and then drain and rinse. Hard water may be softened by boiling, or by the addition of soda ($\frac{1}{8}$ tsp. of soda to 1 pt. of water).
- (2) Cook by *simmering* in softened water until they are soft.
- (3) After simmering, the beans may be baked.

NUTS

Forms in which used:

1. Whole or broken nuts—used as dessert or in cakes, salads, etc.
2. Butters—ground and mixed with other ingredients to make a paste.
3. Meals—ground and used to thicken soups.

SALADS

The series of lessons on vegetable foods being finished, it is a good time to take a salad lesson. All salads were originally made from fresh young plants or salad greens, and though any food material is now used for the purpose, the subject seems to follow naturally the lessons on plant food.

The pupils should derive unusual pleasure from this work. The dishes made are most attractive and appetizing, besides affording an opportunity for each member of the class to display individual artistic skill. None of the principles are new, so that the lesson will be really a review.

The outline of notes for the class will be:

INGREDIENTS OF SALADS

1. Salad plants *proper*, such as lettuce, water-cress, celery, cabbage
2. Cooked vegetables, such as peas, beans, asparagus, carrots, beets
3. Meat—cold, of any kind
4. Fish—cold, of any kind
5. Eggs—hard-boiled
6. Fruit
7. Combinations of the above in great variety.

FOOD VALUES OF SALADS

This depends on the ingredients. If salad greens only are used, the food value is mainly the mineral matter, but the dish will be refreshing and appetizing, and the oil, butter, or egg used in the dressing adds nutriment.

Salads are prepared with little trouble and with no expense for fuel.

PREPARATION OF SALAD INGREDIENTS

1. Have everything cold before combining.
2. Freshen the greens in cold water until crisp.
3. Meat, fish, and solid ingredients should be seasoned some time before using, so that they may absorb the flavours of the seasoning.
4. In most cases do not combine the ingredients with the dressing until just before serving.
 - (1) Salad greens.—Wash thoroughly, and put in cold water until crisp, drain on a towel, wrap in a damp cloth, and put in a cool place. Cabbage and lettuce may be finely shredded.
 - (2) Fruit and cooked vegetables.—Cut into cubes or suitable pieces. Chill and mix with the dressing, to absorb it.
 - (3) Meats.—Remove the fat, skin, and gristle. Cut in cubes and chill.
 - (4) Fish.—Remove the bones, flake, chill, and pour dressing over; but do not mix.

DRESSINGS FOR SALADS

1. Cooked salad dressing:

2 tbsp. sugar	$\frac{1}{4}$ cup vinegar
$\frac{1}{2}$ tsp. mustard	2 eggs
$\frac{1}{2}$ tsp. salt	2 tbsp. butter.

- (1) Mix the first four ingredients in a saucepan and heat until dissolved.
- (2) Beat the eggs very light in a round-bottomed bowl, using a Dover egg beater.
- (3) Beat the vinegar mixture into the eggs.

- (4) Set the bowl, with its contents, over a dish of boiling water, then beat slowly and constantly until the mixture is thickened.
 - (5) Lift the bowl from the heat *at once*.
 - (6) Beat in the butter and set away to cool.
 - (7) If desired, a half cup of whipped or plain cream may be added just before the dressing is used.
2. Uncooked salad dressing:

$\frac{1}{4}$ tsp. salt	4 tbsp. olive oil
$\frac{1}{8}$ tsp. pepper	2 tbsp. vinegar.

- (1) Stir the salt and pepper into the oil.
- (2) Add the vinegar slowly and stir vigorously until well blended and slightly thickened.
- (3) Serve with any salad made of salad greens.

STUDY OF MINERAL FOOD

As the study of mineral food involves a knowledge of chemistry, little more can be done in Junior classes than to teach that certain mineral compounds are required for the body, to point out their two main uses, and to lead the pupils to know the foods which generally supply these.

Their attention should be directed to the fact that all mineral matter is found, in the first place, in the earth's crust, but that, with the exception of salt, animals cannot use it in that form. Plants can use it, and they absorb it from the soil; then we eat the plants, and in that way obtain the mineral substance, or we may obtain it by eating the animals which have eaten the plants. Water also, in making its way through the earth, may dissolve certain minerals and, by drinking the water, we obtain these.

It will not be necessary to teach the names of the minerals which our food must supply, as most of these will mean nothing to the pupils. They might be asked to name one or two which are very familiar; for instance, the lime in bone and the iron in blood. They may be told that there are a few others which they will learn when they study chemistry in the high school.

The pupils have already learned that mineral matter serves two main functions in the body: that is, *building* and *regulating*, and it is a good plan to classify the well-known foods under these two headings. With a little guidance the pupils can do most of this for themselves. They know that milk serves all building purposes in a child's body, and must, therefore, contain mineral matter. Eggs build animal bodies, and must contain this substance also. Meat is the animal body that has been built, therefore meat has this substance; but we shall find in the meat lessons that there is no mineral matter in fat and that the cook cannot dissolve it out of bone, therefore muscle or lean meat must be eaten to obtain it. Seeds, too, contain building material for new plants; therefore, the building mineral matter must be stored in their cells. Hard water is known by the lime it contains, therefore this, if drunk, assists in the formation of bone.

The class must be told that the mineral in the juices of plants is mainly for regulating purposes; that is, to keep our bodies in order, or as we say, healthy. When they get out of order, we usually go to a doctor to be regulated or made well. The medicine which he prescribes often contains some mineral in solution, perhaps iron. The mineral matter which is in the juices of plants, being a more natural form than the mineral matter in the medicine, is more easily made use of in the bodily

processes. This is one reason why people should eat plenty of vegetables and fruit.

Many springs also furnish water with large quantities of mineral matter in solution, which is used mainly for medicinal purposes. The pupils may know some places where we find such springs, and these should be mentioned, such as Preston Springs, Banff, and Mount Clemens, which have become health resorts through the presence of these waters. When the springs are in a distant country and their waters are known to contain a certain mineral which our bodies need, the water is bottled and shipped to us, and may be obtained from a druggist. Hunyadi Janos, Apenta, Vichy, and Apollinaris are well-known medicinal waters shipped from European springs.

SUMMARY OF SOURCES OF MINERAL FOODS

1. Building mineral matter.—Milk, eggs, lean meat, seeds, hard water
2. Regulating mineral matter.—Fruit, vegetables, mineral waters, salt.

NOTE.—This classification will be most useful to the pupils in preparing well-balanced meals in their diet lessons.

DIET

After studying in this elementary way the composition of the animal and vegetable foods, the pupils will be ready for simple lessons on diet. The class may now be said to have a working knowledge of the well-known foods, and they should be given a chance to use this knowledge, by combining and serving these foods for simple meals.

REFERENCE TABLES OF FOOD CONSTITUENTS

It will be helpful in this work, to guide the pupils in making out a reference table of the food constituents. This will give lists of food in which each constituent predominates, as follows:

1. Water:

Beverages (water, milk, tea, coffee, cocoa), fruit, vegetables.

2. Mineral matter:

(1) For building—milk, eggs (yolk and white), lean meat or fish, seeds, hard water

(2) For regulating—fruit, vegetables, mineral waters.

3. Protein:

Milk (curd), eggs (yolk and white), lean meat or fish, seeds.

4. Sugar:

Fruit (juice), non-starchy vegetables (juice), milk (whey), commercial sugar.

5. Starch:

Parts of plants which serve as storehouses:

Tubers—potatoes, artichokes

Roots—parsnip, tapioca, arrowroot

Stem—sago

Seeds—cereals, legumes, some nuts (peanuts, chestnuts).

6. Fat:

Milk (cream), egg-yolk, meat or fish (fat), fruit, as the olive (oil), most nuts (walnut, butternut, pecan, peanut, etc.).

REFERENCE TABLE OF FOOD CONSTITUENTS 135

Besides the necessary substances in food, the pupils must be told that there are other points for the housekeeper to consider when preparing the meals, namely:

1. The amount of each food substance required daily.
2. Special requirements of individuals according to: (1) age, (2) occupation, (3) climate, (4) season.

Under 1, above, it may be explained, that when a meal is prepared which gives the body a correct proportion of each food substance, it is said to be well balanced. From numerous experiments the "Dietary Standard" for one day for a grown person has been calculated to be:

Water—about 5 pints, two of which are taken in solid food

Mineral matter—1 ounce

Protein—3 to $4\frac{1}{2}$ ounces

Fat—2 ounces

Sugar and starch (together)—14 to 18 ounces.

Although the pupils cannot be expected to follow this table accurately, from lack of sufficient knowledge, it will be of some assistance to them in choosing a combination of food for the home meals.

Under 2, above, some of the variations of food are obvious, but some must be taught. Children require simple, nourishing food, which will contain plenty of protein and mineral matter for tissue building as well as much fuel food. Their diet should be varied and abundant.

In old age the diet should also be simple, because of the lack of vigour in the digestive organs, but the amount of building material should be decreased. The food of

old people should contain proportionately more carbonaceous material.

Brain workers require less food than those engaged in active muscular work, and it should be less stimulating and less bulky. Their diet should be in a form that is easily digested.

With the foregoing general ideas in mind, the pupils may be asked to prepare menus for simple home meals. These should be assigned as home work, so that plenty of time can be given to their consideration, and then they may be brought to the class for criticism. The best of these should be chosen for actual practice in school work.

NOTE.—It is intended that this part of the work shall be presented in a very rudimentary way. The teacher should feel satisfied if she succeeds in implanting ideas of the importance of these food considerations, so that the pupils will be ready for more specific instruction to be gained in higher schools or from their own reading. Cheap bulletins on *Human Nutrition*, published by Cornell University, will be excellent reading on this subject.

PREPARING AND SERVING MEALS

Before the pupils are given a meal to prepare and serve, table setting should be reviewed, and the rules of table service taught as follows:

RULES FOR SERVING

1. The hostess serves the soup, salad, dessert, tea, and coffee; the host serves the meat and fish.
2. Vegetables and side dishes may be served by some one at the table or passed by the waitress.
3. Dishes are served at the left of each person, commencing with the chief guest.

4. Guests are served first; ladies before gentlemen.
5. In each course, remove the dishes containing the food before removing the soiled plates.
6. When one course is finished, take the tray in the left hand, stand on the left side of the person, and remove the individual soiled dishes with the right hand, never piling them.
7. Before dessert is served, if necessary, remove the crumbs from the cloth with a brush, crumb knife, or napkin.
8. Tea or coffee may be poured at table or served from a side table by the waitress.

NOTE.—Extra cutlery and napkins should be conveniently placed on a side table, in case of accident.

Where the class consists of twelve or more pupils, it must be divided for the preparation and serving of a meal. Each section should prepare and serve a meal for the others, until all have had experience. As breakfast and luncheon are the simpler meals, they should be taken first in the order of lessons. The duties of the cooking and serving should be definitely settled, and each girl given entire responsibility for a certain part of the work.

Those who are served should represent a family. Members should be chosen to act as father, mother, lady guest, gentleman guest, and children of varying ages, so that the duties and serving of each may be typified.

CHAPTER VIII

FORM IV: JUNIOR GRADE (Continued)

CARE OF THE HOUSE

THE PUPILS of Form IV Junior should be urged to take entire care of their own bed-rooms. The Household Management teacher can do much to encourage them in this. She may include such work as part of the week's practice.

The order of work should be discussed and planned by the pupils, the teacher guiding the class by her questioning. In lessons of this kind, the main work of the teacher is to ascertain what the pupil knows and to systematize her knowledge.

A typewritten sheet of directions may be given each pupil to hang in her room, and may serve as an incentive to her to perform the duties outlined.

DIRECTIONS FOR THE DAILY CARE OF A BED-ROOM

1. Open the window, if it has been closed during dressing.
2. Throw the bed-clothing over the foot of the bed, using a chair to hold it from the floor, or place it over two chairs near the window.
3. Put night clothing to air.
4. Put away any other clothing in drawers and closet.
5. Tidy and dust the top of the dressing-table.
6. Make the bed, after it has been aired at least half an hour.

Once a week the following work should be added:

1. The blankets and comforter should be hung outside to air.
2. The mattress should be turned, and fresh bed-linen placed on the bed.
3. The room should be thoroughly swept and dusted.

After the pupils have had training in the care of their bed-rooms, this experience, together with their lessons in cleaning, should enable them to keep any of the other rooms in the house in good order.

It should be pointed out that, in these days of sanitary building and furnishing, there is no necessity for the semi-annual "housecleaning" of former times. Each week the house can be thoroughly gone over, with the exception of laundering curtains and washing wood-work, and these duties might be taken in turn, a room at a time every week, so that the work will not accumulate.

The class should be taught to consider the economy of time and energy and encouraged to provide themselves with all the latest aids they can afford.

The cleaning methods which are necessary for this work and which have not been formally taught, should now be definitely outlined. These are the weekly sweeping, weekly dusting, and cleaning special met

DIRECTIONS FOR WEEKLY SWEEPING

1. Dust and put away all small articles.
2. Lift the small rugs, sweep them on both sides, out-of-doors if possible, and leave them to air. Rugs too large to take out should be brushed and folded over to allow of sweeping the under side and wiping the floor beneath.

3. Cover the furniture with dust sheets.
4. Shut the doors and open a window.
5. Begin at the side of the room farthest from the door and sweep toward the centre; sweep from the other side toward the centre; gather the dust in a dust-pan and empty it into the garbage pail or fire.
6. Put away the broom and dust-pan.
7. Leave the room shut up for a few minutes, in order to allow the dust to settle.
8. Use a "dustless" mop to dust the floor.

DIRECTIONS FOR WEEKLY DUSTING

1. Use a soft cotton or cheesecloth duster very slightly dampened.
2. Roll up the covers that are over the furniture and carry them outside, in order to shake off the dust.
3. Wipe the dust from the furniture, pictures, window-sills, ledges, doors, and baseboard, being careful not to scatter it in the air.
4. Change the duster when necessary.
5. Replace the small articles.
6. Wash and dry the dusters.

CARE AND CLEANING OF METALS

IRON OR STEEL

Utensils made of these are heavy, but strong and durable, and hold the heat well.

1. Care:

They must be kept dry and smooth. Moisture causes rust, roughens the surfaces of the

utensils, and makes them more difficult to clean. If they are not to be used for some time, the surfaces should be greased or coated with paraffin.

2. Cleaning:

- (1) Wash in hot soap-suds, rinse in hot water, and dry thoroughly.
- (2) If food is burned on, scour with some gritty material or boil in a solution of washing soda, rinse in hot water, and dry thoroughly.

TIN

Utensils made of this are light and inexpensive; they are good conductors of heat, but they are also good radiators and lose heat quickly.

1. Care:

As tinware is steel or iron coated with liquid tin, the grades vary according to the "base-metal" used and the thickness of the coating. Utensils made of this metal must be carefully kept from scratches, since deep scratches expose the base-metal and allow the formation of rust.

2. Cleaning:

- (1) Wash in hot soap-suds, rinse, and dry thoroughly.
- (2) If food is burned on, boil in a weak solution of washing soda, rinse in hot water, and dry thoroughly.

NOTE.—Whiting may be used to brighten the tin, but scouring is not recommended, as it wears off the coating.

GRANITE AND ENAMEL WARE

Utensils made of this are attractive, not heavy, and they do not tarnish or rust.

1. Care:

These wares are made by coating steel or sheet-iron with a specially prepared glassy substance called enamel or glaze. Two or three coats are applied. The durability depends on the ingredients used in the glaze and on the number of coats applied.

Such utensils should be heated gradually, scraped carefully, and handled without knocking, to avoid "chipping".

2. Cleaning:

(1) Wash in hot soap-suds.

(2) If stained, use some scouring powder; wash and dry.

(3) If food is burned on, boil in a solution of washing soda and then scour; wash and dry.

ALUMINIUM

Utensils made of this are very light in weight and, as they have no crevices, are easily cleaned. They are also good conductors of heat.

1. Care:

This metal warps under a high temperature, and should, therefore, be used with care. Do not turn the gas on full, or, if used over wood or coal fires, be sure to leave the stove lid on. Some foods injure the metal, if they are allowed to remain in it very long.

2. Cleaning:

- (1) Wash in hot water, with mild soap. Alkalies should not be used, as they darken the surface.
- (2) If food is burned on, the dish should be soaked in water and then scoured with bath-brick or emery powder.
- (3) Whiting may be used to brighten it.

ZINC

This is not used for utensils, but for table tops and for placing under stoves, etc.

Cleaning:

- (1) Use hot water and mild soap. Alkalies and acids affect zinc and should be used with care.
- (2) If stained, rub with coal-oil or a paste made of coal-oil and soda, and then wash in hot water.

GALVANIZED IRON

This is used for garbage pails, ash pans, stove pipes, etc. It is made by dipping sheet-iron into melted zinc.

Cleaning:

The same as for zinc.

COPPER OR BRASS

Utensils made of these are heavy but durable and are good conductors of heat. They are dangerous, if not properly cleaned.

Cleaning:

- (1) Wash in hot water, using a little washing soda to remove any grease, rinse well, and dry.
- (2) If stained or tarnished, scour with salt and vinegar, then rinse thoroughly, and dry.

SILVER

This is used for spoons, knives, forks, and serving dishes, but never for cooking utensils, on account of its cost. It is the best conductor of heat among the house metals.

Cleaning:

- (1) Wash in hot soap-suds.
- (2) If stained or tarnished, use whiting or silver polish, wash, and dry.

RECIPE FOR SILVER POLISH

2 tbsp. borax
1 cup boiling water
 $\frac{1}{2}$ cup alcohol
whiting.

1. Dissolve the borax in the water.
2. When cold, add the alcohol and enough whiting to make a thin cream.
3. Bottle, and shake when used.

NOTE.—The care and cleaning of the metals out of which ordinary utensils are made, such as granite ware, tin, and steel, may be taught incidentally as the utensils are used.

CHAPTER IX

FORM IV: JUNIOR GRADE (Continued)

LAUNDRY WORK

THIS work is but a continuation of the lessons on cleaning. It is the process of removing foreign matter from cotton, linen, woollen, or silk fabrics by the use of water and additional cleansing agents. It also includes the finishing of these materials by the use of blueing, starch, and heated irons, to restore as far as possible their original appearance.

The principles of laundry work have been taught in the washing of dish cloths and towels, and now these principles have only to be extended to white cotton and linen clothes of any kind.

The pupils may be asked to bring soiled articles of white linen or cotton from home for use at school in exemplifying the necessary processes. In schools which lack an equipment, these processes may be discussed in class and then practised at home. The teacher should choose from the following outline what is most suitable to the class:

OUTLINE OF LESSONS ON THE WASHING OF WHITE COTTON AND LINEN CLOTHES

LESSON I

MATERIALS

1. Water:

(1) Use:

- (a) To soften and dissolve certain foreign substances in the clothes.

- (b) To carry away all the foreign matter that has been dissolved or rubbed out of the clothes.

(2) Kinds:

- (a) *Hard water*
(b) *Soft water*

For laundry purposes, the water should be soft. The quality known as hardness, which some water has, is due to the lime which it has dissolved in making its way through the earth.

Water is said to be temporarily or permanently hard according to the kind of lime it has in solution. Temporarily hard water may be softened by boiling; the lime will be deposited, as may be seen in the "furring" of tea-kettles. Boiling has no effect in softening permanently hard water, so a substance known as an *alkali* is used for this purpose.

(3) Methods of softening water by alkalies.—For each gallon of water use one of the following:

- (a) One tablespoonful of borax or ammonia dissolved in one cup of water.
(b) Two tablespoonfuls of a solution made by dissolving one pound of washing soda in one quart of boiling water.
(c) One fourth tablespoonful of lye dissolved in one cup of water.

2. Alkalies (borax, ammonia, washing soda, lye):

(1) Use:

- (a) To soften hard water
- (b) To assist in dissolving greasy substances.

(2) Kinds:

- (a) *Borax*.—This alkali is one of the mildest, and for this reason is less harmful to the clothing. It is useful when an alkali is required to soften water for coloured clothes or woollens. It also has a tendency to keep white clothes a good colour.
- (b) *Ammonia*.—This also is a mild alkali, but is apt to "yellow" white materials. As it is very volatile, it should not be used unless the washing can be done quickly.
- (c) *Washing soda*.—This is a cheap substance and stronger than borax or ammonia. It should be made into a solution before it is used, for fear of too great strength.
- (d) *Lye, or caustic soda*.—This alkali is very strong and should be employed with great care. It must not be used except in weak solutions, otherwise it would entirely dissolve fabrics. It is not advisable for home laundry work.

3. Soap:

(1) Use.—To act on greasy matter.

Soap-suds penetrate fabrics more completely than water alone, and when the soap comes in contact with fatty material, it *emulsifies* it, that is, very finely divides it into minute particles, so that it can be easily removed. If a soap is used that

contains free alkali, this substance unites with the greasy impurities to form new soap which has cleansing value.

- (2) Kinds.—(a) Neutral, (b) medium, (c) strong. All soap is a compound of an alkali and fat, and according as one or the other of these substances predominates, the kind of soap is determined.

When just enough alkali is used to completely *saponify* the amount of fat, the product is called a neutral, or mild, soap. When an excess of alkali is present, the soap is termed medium or strong, according to the amount of free alkali it contains.

A mild soap should be used when free alkali would be injurious, as in washing woollens or fabrics that have delicate colours.

4. Soap substitutes, or adjuncts:

- (1) Use.—To act alone or with soap in exerting a solvent action on greasy impurities, so that the cleansing process may be facilitated.

(2) Kinds:

- (a) *Alkalies*.—These must be used in excess of the amount needed for softening the water.
- (b) *Harmless solvents, such as turpentine, paraffin, coal-oil, gasolene*.—The clothing must be well rinsed to get rid of any odour.

(c) *Washing powders*.—These are prepared mixtures of soap and some other solvent of greasy matter.

5. Blueing:

(1) Use.—To make clothes which have a yellow tinge appear whiter in colour.

(2) Kinds.—There are several kinds on the market, but the names of these will be of no value to the class.

NOTE.—Sufficient blueing should be used to make the blueing water a pale sky-blue colour when a little of it is lifted in the hand.

6. Starch:

(1) Use:

(a) To stiffen fabrics and thus improve their appearance.

(b) To give fabrics a glazed surface, so that they will shed dust and other impurities.

(2) Kinds.—(a) Cold starch, (b) boiled starch.

Raw starch does not give as durable a finish as cooked starch, but it does give greater stiffness. A fabric will take up more starch in the raw form, and the heat of the iron cooks the starch, thus producing the stiffness. The "body", or stiffness, produced by cooked starch is usually preferable, though on account of its preparation, it is not so convenient to use.

(3) Recipes for starch—

(a) Cold Starch

- 2 tbsp. laundry starch
- $\frac{1}{2}$ tsp. borax
- 2 cups cold water.

Dissolve the borax in a little boiling water. Add the cold water gradually to the starch and mix thoroughly. Add the dissolved borax and stir well before using.

(b) Boiled Starch

- 2 tbsp. starch $\frac{1}{2}$ tsp. lard, butter, or paraffin
- 4 tbsp. cold water 1 qt. boiling water.

Mix the starch with the cold water until free from lumps. Add the lard, then gradually stir in the boiling water, and keep stirring until thickened. Cook fifteen minutes and use hot.

NOTE.—Borax in starch gives greater gloss and increases the stiffness. It also gives more lasting stiffness. Lard, butter, or wax is used to give a smoother finish and to prevent the starch from sticking to the iron.

LESSON II

PREPARATION FOR WASHING WHITE LINEN
OR COTTON CLOTHES

1. Sort the clothes:
 - (1) Table linen and clean towels
 - (2) Bed and body linen
 - (3) Handkerchiefs
 - (4) Soiled towels and cloths.
2. Mend the clothes.
3. Remove stains.
4. Look after necessary materials.

PROCESS OF WASHING WHITE LINEN
OR COTTON CLOTHES*Steps**Method*

1. Soaking:

Wet the clothes; rub the soiled parts with soap and roll each article separately; pack in a tub, placing the clothing most soiled at the bottom; cover with warm soapy water and soak from one hour to over night.

The soaking softens and loosens the fibres of fabrics, so that the foreign matter in them can be more easily separated. It also dissolves the soluble impurities in the fabrics.

2. Rubbing:

Wring the clothes out of the soaking water, and place them in a tub of clean warm water or soap-suds; rub the soiled parts first on one side and then on the other, using the knuckles, a washboard, or a washing-machine. When each piece is clean, wring it tightly.

The rubbing scrapes or rubs out the foreign matter which has been loosened by the soaking.

3. Rinsing:

Shake out each piece and put it into a tub of clear water; rub, and move about in the water to get rid of any soiled water that the clothes may contain; wring tightly.

4. Boiling:

Shake out each piece and place it in a boiler of cold water with or without soap; bring to boiling heat, and boil briskly for twenty minutes.

The boiling kills any germs and assists in whitening the clothes.

5. Rinsing:

Lift the clothes from the boiling water by means of a clothes stick and place them in a tub of clear, cold water; proceed as in the first rinsing.

6. Blueing:

Open out each piece and place one or two at a time in a tub of blueing water for just a moment; wring tightly, and shake out each piece.

The blueing tends to counteract any yellow tinge in the clothes, making them appear whiter.

7. Starching:

Dip one piece at a time into the starch mixture until well saturated; then wring.

Only certain articles or parts of articles will require this part of the process, to give them body or stiffness and, it may be, glossiness.

8. Hanging:

Shake out each piece thoroughly; fasten to a clothes-line or hang on a rack to allow the moisture to evaporate. This should be out-of-doors in the sunlight if possible.

REMOVAL OF STAINS

Foreign matter which is difficult or impossible to remove by the ordinary washing process is called a *stain*. Such matter is not dissolved by the usual cleansing agents used in laundry work, such as water and soap, but requires some special solvent to act on it. The choice of the agent to be used will depend on the nature of the foreign matter to be removed. In some cases it is difficult to find

an agent which will not act also on the colour of the fabric; in other cases to find one which does not injure the fibre of the goods.

The pupils should be asked to give instances from their own experience where special solvents were used to remove stains, and be required to make a list of these. If necessary, the teacher should supplement this list with the names of other agents and the methods of using them.

OUTLINE OF LESSONS ON THE WASHING OF WOOLLENS

The washing of woollen materials is part of the Course for the work of the Senior Grade of Form IV, but, for the sake of convenience, the laundry lessons of both Grades of Form IV are outlined in one section of this Manual.

Before allowing the class any practice in this branch of laundry work, it will be necessary for the teacher to make certain principles very clear:

1. That wool is an animal product. As such it tends to be shrunken and hardened by (1) heat, (2) alkalies.
2. That the surface of each wool fibre woven into woollen materials is seen under the microscope to be covered with notches, or scales. If these notches in any way become entangled, the material is thereby drawn up, or "shrunken".
3. That these notches may be entangled by:
 - (1) Wetting the woollen material and then rubbing or twisting it. When the fibres are wet, they expand somewhat and the projecting scales, or notches, are loosened. If the material is rubbed at this time, the notched edges interlock.

- (2) The use of strong soaps or alkalis. These act chemically on the fibres and soften and expand them, causing the notched edges to become so prominent that they catch in one another.

NOTE.—The structure of woollen fibres may be sketched on the black-board and compared with those of cotton and linen.

To impress the foregoing principles, a few experiments will be found most useful.

EXPERIMENTS WITH CLOTH MADE OF WOOL FIBRE

1. Boil a piece of new woollen cloth for five minutes. Dry, and compare with an original piece.
2. Saturate a piece of new woollen cloth with a strong solution of washing soda. Dry, and compare with an original piece.
3. Wash a piece of new woollen cloth in each of the following ways:
 - (1) By rubbing soap directly on the cloth and then sousing the goods in the water.
 - (2) By using a soap solution instead of the soap, as in (1).
 - (3) By rubbing on a wash-board.

In each case dry the cloth and compare with an original piece.

After the results of the experiments have been discussed, the pupils may formulate a series of "points" to be observed in the washing of woollen fabrics.

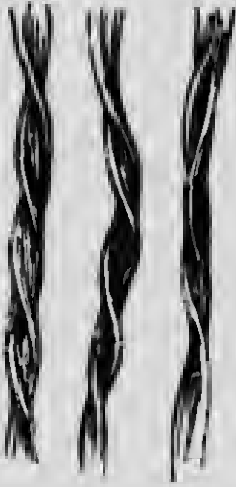

Cotton fibres magnified

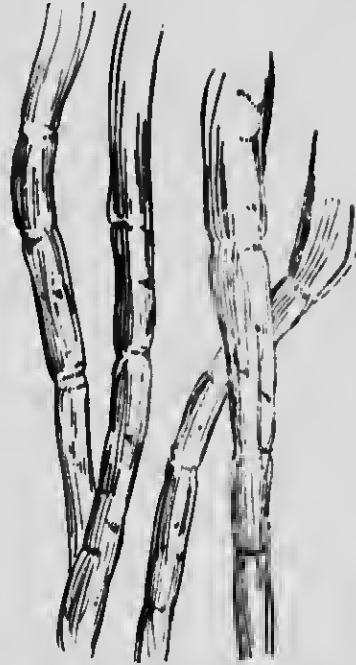

Linen fibres magnified

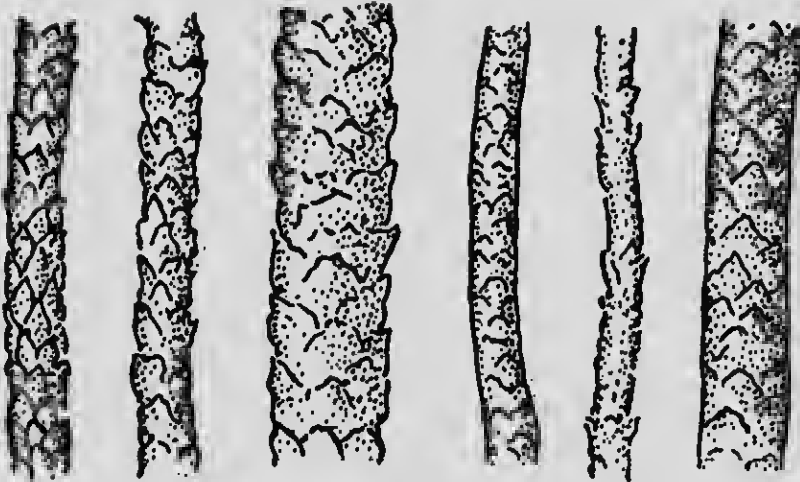

Woollen fibres magnified

POINTS IN WASHING WOOLLENS

1. Use lukewarm, soft water.
2. Do not use strong soaps or alkalis.
3. Do not rub soap directly on the woollen material, but use soap solutions.
4. Do not rub or twist woollen cloth when it is wet.
5. Do not boil to sterilize.
6. Do not dry in extreme heat.

STEPS IN WASHING WOOLLEN MATERIALS

1. Shake or brush the clothing to free it from dust.
2. Put it into lukewarm, soapy water to soak for a few minutes.
3. Wash on both sides by squeezing and sousing in the water.
4. Rinse in clear, lukewarm water; use several waters, if necessary, to remove the soap.
5. Pass through a loosely set wringer or squeeze the water out by hand.
6. Shake, in order to raise the woolly fibres.
7. Dry in a moderate temperature, in a wind, if possible.

CHAPTER X

FORM IV: SENIOR GRADE

FOODS

THE Senior Fourth class is the preparatory class for entrance into the high school, and for many girls it is the final school year. For this reason the Course of this year should cover as many of the remaining household operations as possible.

The training of the previous years should have formed good habits of work and have given experience in ordinary cleaning, and in the cooking and serving of the simple food materials. Through this training the pupils should also have been impressed with the value of food, and should have learned the sources of food and of all well-known household materials.

The training of this last year, while continuing the Junior work, should also emphasize the household processes that require greater mental development to understand and greater practical skill to carry out. It is the border year between the public school and the high school, and must necessarily anticipate the elementary science of the latter. In this year more responsibility should be given to the pupils and more originality should be expected of them. Where they have hitherto followed recipes and been given rules, they should now follow principles and deduce rules.

Of the several topics outlined in the Course for Form IV Senior, it is advisable to start with the preservation of food. Fruit and vegetables are most plentiful when the

school year opens, and September is the most opportune month to preserve these for winter use. Facts concerning food preservation may have been taken incidentally in previous lessons, but now the subject should be systematically taught, so that canning, preserving, and pickling may be intelligently practised.

PRESERVATION OF FOOD

CAUSE OF DECAY

The lesson may be introduced by referring to the unusual attention given to fruit at the time of ripening. The economical housekeeper takes certain foods when they are most plentiful and preserves them for use when they are not in season. Some foods require special care to keep them from decaying. The decay is caused by the action of microscopic plants called "bacteria", which get into the food.

BACTERIA

It is difficult for any one to get a correct conception of bacteria; especially is it so for children. The teacher should be most careful not to attempt to give the class unimportant details, but the few necessary facts should be made very clear and real. The following points should be impressed:

1. Bacteria are plants. (This fact should be kept clearly in mind.)
2. They are microscopic in size and hence the more difficult to deal with.
3. They are found everywhere that there is life—in the air, in water, in the soil.

4. They multiply very rapidly under favourable conditions.
5. Some bacteria are useful to the housekeeper; many kinds are her enemies.
6. Some of these enemies get into food and, growing there, cause a change in it—then we say the food is spoiled.

CONDITIONS OF BACTERIAL GROWTH

All plants have the same requirements. Any well-known plant may be put before the class to help them to think of these. They must be told that microscopic plants differ from other plants in one respect; they do not need light. Hence bacterial requirements are as follows: (1) water, (2) food, (3) air (oxygen), (4) heat.

The class should be led to see that if any one of these conditions is removed, the remaining ones are insufficient for the plant's activity.

MEANS OF OVERCOMING BACTERIA

To the housekeeper, preserving food means overcoming bacteria. There are only two ways of doing this, either of which may be chosen:

1. Kill the bacteria in the food and exclude others.
2. Subject the food to conditions which are unfavourable for bacterial growth.

In the first way, extreme heat is used to kill the bacteria in the food, and then while hot, the food is sealed to keep out other bacteria: Example, canning.

In the second way, conditions are made unfavourable to the bacteria in the food, as follows:

1. The bacteria are deprived of water; the food is dried.
2. The bacteria are deprived of sufficient heat to be active; cold storage is used.
3. Large quantities of certain substances which are detrimental to the growth of bacteria are put into the food, and the bacteria become inactive. Examples: salt, sugar, spices, vinegar, smoke, or certain chemicals.

When the lesson is finished, the class is ready to practise the principles it involves. The lessons on the special preservation of fruit may follow at once.



Utensils used in canning

CANNING

As canning is the method of preservation most commonly used, practice should be given in this method. In rural schools with a limited equipment, it may be that only one jar can be prepared. In other schools, it may be impossible to provide each pupil with material for work, on account of the expense. In the latter case, the materials

may all be brought from home, or each pupil may bring her own jar and fruit, and the school supply the sugar.

Instruction on the care of jars and the preparation of fruit and syrup must precede the practical work.

CARE OF JARS

1. See that the jars are air-tight; partly fill the jar with water; place rubbers, covers, and rims; screw tightly, and invert. If any water oozes out, the jar is not air-tight. Often an extra rubber will correct the trouble.
2. Wash the jars thoroughly with the aid of a small brush.
3. Sterilize the jars in every part; dip them in boiling water, or place them on a rest (folded paper or wooden slats) in a kettle, to prevent the jars from touching the bottom. Fill and surround them with tepid water, then place them over heat until the water boils. Keep them in the boiling water until ready to fill with fruit. Dip the rubber bands in boiling water, but do not allow them to remain in it. Use new rubbers each season.
4. When filling the jars, place them on a folded cloth wrung out of warm water, then seal, and invert until cool.

PREPARATION OF FRUIT

Use fresh, sound fruit, not too ripe.

1. Berries.—Pick over, wash in a strainer, and hull.
2. Currants, gooseberries.—Pick over, wash, remove ends and stems.
3. Cherries.—Pick over, wash, remove stones and stems.
4. Plums.—Pick over, wash, remove stems, and prick three or four times with a silver fork, in order to prevent the steam bursting the skin.

5. Pears, apples.—Pick over, wash, pare, and, to prevent discoloration, keep in cold water until used.
6. Peaches.—Pick over, plunge into boiling water a few seconds (using a wire basket), then into cold water; peel; drop into cold water to prevent discoloration.

SYRUP FOR CANNING

Use about 1 cup of water for each pint can.

No. 1 Syrup.—Equal parts of sugar and water, or 1 cup of water and 1 cup of sugar.

No. 2 Syrup.— $1\frac{1}{2}$ cups of water and 1 cup of sugar.

1. Use No. 1 syrup for watery fruits and acid fruits.
2. Use No. 2 syrup for pears, peaches, sweet plums, sweet cherries, etc.

METHODS OF CANNING

1. Fruit cooked in a steamer:

Fill the sterilized jars with prepared fruit, with or without syrup. Place the covers, but do not fasten them down. Stand the jars in a steamer over cold water. Cover the steamer and heat to the boiling point. Steam at least fifteen minutes, or until the fruit is tender. Remove from the steamer, fill to overflowing with boiling syrup, and seal at once. Invert.

2. Fruit cooked in a boiler:

Put a false bottom in the boiler, to prevent the jars from being broken. Fill the jars with fruit, and add syrup if desired. Cover and place the jars in the boiler without touching one another. Pour in tepid water to within an inch of the top of the jars and bring gradually to boiling heat. Cook and finish as directed in 1, above.

3. Fruit cooked in an oven:

Fill sterilized, hot jars with prepared raw fruit and cover with hot syrup. Place the jars in a moderate oven, in a baking dish containing about an inch or two of hot water. Cook and finish as in 1, above.

4. Fruit cooked in a kettle:

Make a syrup in a fairly deep kettle. Put the prepared fruit into it and cook gently until tender. When the fruit is cooked, lift carefully into hot, sterilized jars, and fill to overflowing with boiling syrup. Seal at once and invert.

NOTE.—By Methods 1, 2, and 3 the fruit is kept more perfect in shape and loses less flavour than by Method 4. Methods 2 and 4 are best to choose for class practice.

After the lesson in Canning, it may not be wise to take the school time for further practice in the preservation of fruit. When such is the case, the theory of jam and jelly making may be discussed in class for home practice. The notes of these lessons may appear as follows:

JAMS AND PRESERVES**POINTS IN MAKING JAM**

1. In this method sugar is the preservative, therefore the amount used must be large.
2. The quantity of sugar used is from three quarters to one pound of sugar to each pound of fruit. Little or no water is used.
3. The natural shape and appearance of the fruit is not kept.
4. The flavour of the fruit is not so natural, on account of the excessive sweetness.
5. The jar need not be sealed, but merely covered.

JELLY

COMPOSITION OF JELLY

1. Jelly is made from certain fruit juices and sugar.
2. The fruit juice must contain a certain amount of *pectin*, or jelling principle, and also a certain amount of acid.

PARTS OF FRUIT CONTAINING MOST PECTIN

(1) Skin, (2) core, (3) pits and seeds.



Utensils used in making jelly

FRUITS CONTAINING MOST PECTIN

1. Currants
2. Crab-apples, apples
3. Quinces
4. Cranberries, blackberries, raspberries
5. Grapes, if rather green.

METHOD OF MAKING JELLY

1. Cut up the prepared fruit if necessary, and add barely enough water for cooking.
2. Set over the heat and simmer gently until the cellulose is very soft.
3. Turn into a jelly-bag, and drain for a number of hours or over night, in order to get rid of the cellulose.
4. Measure the drained juice and take the same quantity of sugar.
5. Heat the sugar in the oven.
6. Boil the juice gently and steadily for twenty minutes, skimming when required.
7. Add the hot sugar and boil very gently from three to five minutes, or until the mixture will jelly when tested.
8. Empty at once into hot glasses and set to cool.
9. When cold and firm, cover and set in a cool, dark place.

METHODS OF COVERING JAM OR JELLY

1. Melt paraffin and pour a layer on each glass, cover with a tin cover or paper pasted with egg-white.
2. Cut clean, white paper to fit the glass, and lay on the jelly when it is firm and cold. Place the cover or paper as in 1, above.

PICKLING

Where the teacher finds it desirable, a lesson should now be given on pickling, with or without class practice. At least one or two good recipes may be given for home use.

There are no new principles to teach. The use of vinegar, salt, and spices as preservatives should be reviewed.

CHAPTER XI

FORM IV: SENIOR GRADE (Continued)

COOKERY

THE FIRST work in cookery, for this Form, should consist of practice lessons, which will test the ability of the class in cooking the simple animal and vegetable foods. The recipes used for these should be such as to attract the interest of the pupils, and each may be a combination of several food materials. Cream soups, custards, scalloped dishes, and shepherd's pie, would be useful for this purpose.

It is desirable that this test shall be made in as few lessons as possible, because nearly all the time in cookery for this year will be required for the new work, namely, a series of lessons on flour mixtures.

OUTLINE OF LESSON ON FLOUR

Flour is a food substance ground into a powder.

1. Sources of flour:

- (1) Certain cereals—wheat, rye, barley, buckwheat, rice
- (2) Potatoes.

2. Kinds of flour made from wheat:

- (1) Graham flour—the entire wheat seed is ground.
- (2) Whole wheat flour—the first outer coat of cellulose with its valuable mineral contents is removed before the seed is ground.

- (3) White flour—only the central white part of the seed is ground.

NOTE.—The pupils should be given specimens of fall wheat to examine, so as to compare the outer coat of cellulose with the central white part of the grain.

3. Composition of white flour:

- (1) Starch—a fine, granular, white substance
- (2) Gluten—a sticky, yellowish, elastic substance (a protein food).

To find the substances in white flour, each pupil should mix half a cup of bread flour with enough cold water to make a dough. She must then be taught to knead it. This knowledge will be of use later in the bread lessons. After it is thoroughly kneaded until it is smooth and well blended, the dough should be washed in several waters. The first washing water should be poured into a glass and allowed to settle, to show the starch. After all the starch is washed away, the gluten will remain.

The gluten may then be put into a greased pan and baked, to demonstrate that it admits of distention, and also to show that it may be stiffened permanently by heat into any distended shape. The baked gluten should be reserved to be used as a specimen in succeeding lessons.

4. Kinds of wheat flour:

- (1) Bread flour—contains much gluten.
- (2) Pastry flour—contains little gluten.

NOTE.—Macaroni is a paste made from wheat flour which contains much gluten.

5. Tests for bread flour:

- (1) The colour is a deeper cream than pastry flour, on account of the larger amount of gluten which it contains.



MICROCOPY RESOLUTION TEST CHART

(ANSI and ISO TEST CHART No. 2)

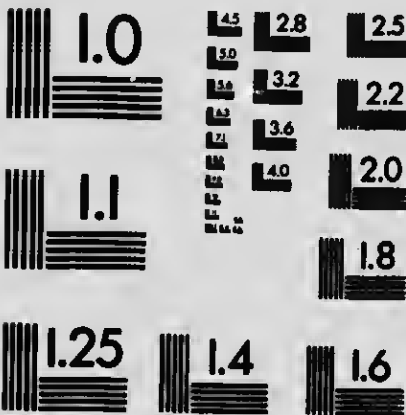

APPLIED IMAGE Inc

1653 East Main Street
Rochester, New York 14609 USA
(716) 482 - 0300 - Phone
(716) 288 - 5969 - Fax

- (2) When squeezed, it will not hold the impress of the hand.
- (3) When the flour is made into a dough and washed, about one fourth of the original quantity remains as gluten.

OUTLINE OF SERIES OF LESSONS ON FLOUR MIXTURES

LESSON I

1. Meaning of flour mixtures:

A lightened mixture of flour and liquid, with or without other ingredients, is called a flour mixture.

2. Kinds of flour mixtures:

- (1) Batters.—(a) Pour batters—pancakes, popovers
(b) Drop batters—cake
- (2) Doughs.—(a) Soft dough—cookies, baking-powder biscuits, doughnuts
(b) Stiff dough—pastry.

3. Methods of mixing flour mixtures:

- (1) Stirring.—A roundabout movement which simply mixes the ingredients.
- (2) Beating.—An upright, circular movement, which incorporates air into the ingredients while being mixed.
- (3) Folding.—A slow, careful beating, which blends the ingredients without loss of the air they contain.
- (4) Kneading.—A movement of the hands to blend the ingredients and also to incorporate air.
- (5) Cutting.—A hacking movement of a knife to mix fat through flour.

4. Framework of flour mixtures:

- (1) Gluten
- (2) Gluten and egg-white.

To show the framework, the gluten baked in the flour lessons should be used. It should be pointed out as the skeleton of the mixture which upholds the entire structure and on which the other ingredients depend. To have light mixtures, this framework must admit of being expanded and also of being stiffened permanently into the stretched shape. Since egg-white has both of these necessary qualities, it may be used for a framework either alone or in combination with gluten.

It should also be observed that a mixture of ingredients light in weight does not prevent the framework from rising as much as heavy ones do.

The pupils will see that the framework of a mixture must increase in size in order to make the mixture light, but it must be made very clear that, while heat stiffens any framework, it will not distend it. Some other agency is required for this.

5. Lightening agents used in flour mixtures:

- (1) Air.—Incorporated by beating, kneading, and sifting.
- (2) Steam.—Incorporated in the form of a liquid which, when heated, changes to steam.
- (3) Carbonic acid gas.—Formed in the mixture by the chemical union of soda with some acid. Examples: soda and sour milk; soda, cream of tartar and water; soda and molasses.

The lightening agents, air and steam, may be taught from the samples of baked gluten. Experiments will show how to produce the carbonic acid gas.

Experiments:

1. Put into a thick glass $\frac{1}{2}$ tsp. of soda and $\frac{1}{4}$ tsp. of cream of tartar. Mix, and note the result. Stir in $\frac{1}{2}$ cup of cold water, and note the result.
2. In No. 1, use hot water in place of cold, and note the result.
3. Put $\frac{1}{4}$ cup of sour milk in a glass. Stir into the milk $\frac{1}{4}$ tsp. of soda, and note the result.
4. Put 1 tbsp. of molasses in a glass. Stir into the molasses a pinch of soda, and note the result.

Baking-powder:

It may now be explained that, for the sake of convenience, soda and cream of tartar may be obtained already mixed, in accurate proportions of two parts of acid to one of the soda. This mixture is known as baking-powder. As very little moisture is necessary to start the action of the powder, a little cornstarch is added to it to keep it dry. For the same reason, it should always be kept tightly covered.

Soda is made from common salt and is cheap, but the source of cream of tartar makes it expensive, so that good baking-powder cannot be low priced. If such be advertised, it is usually adulterated.

As soon as the foregoing principles of flour mixtures are understood, they should be put into practice. The lessons on cake, bread, and pastry should follow in the order named, with as much practical work in connection with each as the time will allow.

CAKE MAKING

LESSONS II AND III

1. Classes of cake:

- (1) Cakes without butter.—These mixtures contain no heavy ingredients and have little weight depending on the framework. They are lightened by air and steam only. Examples: sponge cake, angel cake.
- (2) Cakes with butter.—These are mixtures having ingredients of greater weight; and the three lightening agents—air, steam, and carbonic acid gas are used to raise them. Examples: pound cake, chocolate cake, nut cake, etc.

NOTE.—Practice should be given in making at least one of each kind of cake, to demonstrate the method of mixing employed.

2. General directions for making cake:

- (1) Attend to the fire, so as to have the oven at a proper heat.
- (2) Grease the pans thoroughly; greased paper may be used to line the bottom of the tin, but, in the case of fruit cake, the whole tin should be lined.
- (3) Have everything ready, so that the mixing may be quickly done.
- (4) Use pastry flour.
- (5) Use fine granulated sugar to ensure its being dissolved.
- (6) Blend the ingredients thoroughly, and at the same time incorporate as large an amount of air as possible.

- (7) Fill the pan about two-thirds full, pushing the mixture well to the corners and sides, so as to leave a depression in the centre.
- (8) Attend carefully to the baking.

3. General rules for mixing cake:

(1) Cake without butter—

- (a) Separate the yolks and whites of the eggs.
- (b) Beat the yolks until thick and lemon-coloured.
- (c) Add sugar to the yolks gradually and continue beating; add the flavouring.
- (d) Beat the whites until stiff and dry, then *fold* them into the first mixture.
- (e) Gradually sift and fold in the flour until well mixed.

(2) Cake with butter—

- (a) Cream the butter by working it with a wooden spoon.
- (b) Add the sugar gradually by stirring it in.
- (c) Beat the eggs until light, and add to the first mixture. (The eggs may be separated and the whites added later.)
- (d) Add the liquid and heat until the sugar is thoroughly dissolved.
- (e) Mix the flour and baking-powder in a sifter and gradually sift and beat it into the mixture until it is thoroughly blended.
(Liquid and flour may be added alternately.)
- (f) Fold in the stiffly beaten whites, if the eggs have been separated.

- (g) If fruit, peel, nuts, etc., are used, they should be floured out of the quantity allowed for the cake and added last.

4. General directions for baking cake:

(1) Small, thin cakes should be baked in a hot oven.
Examples: cookies, layer cake.

(2) All loaf cakes require a moderate oven.

(3) In baking cakes, divide the time stated in the recipe into quarters as follows:

First quarter—mixture should begin to rise.

Second quarter—mixture should continue rising.

Third quarter—mixture should begin to brown and to stiffen into shape.

Fourth quarter—mixture should finish browning and stiffening and shrink slightly from the sides of the pan.

(4) Mixture is cooked when a slight pressure leaves no dent, or when a small skewer or fine knitting-needle put into the centre comes out clean and dry.

To the inexperienced minds of the girls in the Fourth Form, to whom the study of flour mixtures is new, the number and variety of these seems very large. All cook books give an almost endless collection of recipes for cakes, cookies, muffins, etc., and to the pupils each of these seems an entirely new mixture. In reality, many of them are but slight variations of the same type. A certain mixture of materials is used for a foundation, and numerous varieties are made from this by addition, subtraction, or substitution of ingredients. The original mixture is called

a *basic recipe*. Instead of teaching isolated mixtures, it will be found an excellent idea to give the class the basic ingredients for a recipe and encourage them to suggest variations, either original or from memory.

Typical basic recipes for cake and biscuits are given below :

BASIC RECIPE FOR CAKE

$\frac{1}{4}$ cup butter	$1\frac{1}{2}$ cup flour
$\frac{1}{4}$ cup sugar	$\frac{1}{4}$ tsp. salt
2 eggs	2 tsp. baking-powder
$\frac{1}{2}$ cup milk	$\frac{1}{2}$ tsp. vanilla.

VARIATIONS OF BASIC RECIPE FOR CAKE

1. Spice cake :

To the basic recipe add 1 tbsp. of spice. Sift in the spice with the flour.

2. Nut cake :

Add $\frac{1}{2}$ cup of chopped nuts. Increase the baking-powder by one third. Put a little of the flour on the nuts and beat them in at the last.

3. Fruit cake :

Add $\frac{1}{4}$ cup of currants, raisins, figs, or dates, or a mixture of all. Increase the baking-powder by one third. Flour the fruit and add it last.

4. Chocolate cake :

Add $\frac{1}{2}$ cup grated chocolate. Increase the milk by 2 tbsp. Heat the chocolate in the milk just enough to dissolve it. Cool the mixture and use in place of milk.

BASIC RECIPE FOR BISCUITS, ETC.

2 cups flour
½ tsp. salt
4 tsp. baking-powder
2 tbsp. fat (butter, lard, or dripping)
About ¾ cup milk.

VARIATIONS OF BASIC RECIPE FOR BISCUITS

1. Sweet biscuit:
Add 2 tbsp. of sugar after the fat is added.
2. Fruit biscuit:
Add 2 tbsp. of sugar and ½ cup of fruit, (currants, raisins, peel, or a mixture of all) after the fat is added.
3. Scones:
Add 2 tbsp. of sugar, and use one egg and only ½ cup of milk. Beat the egg until light, add to milk, and use this for liquid. Form into round cakes about eight inches in diameter, and cut into quarters.
4. Fruit scones:
Add ½ cup of fruit to the scone recipe.
5. Short cake for fruit:
Same as scones, but double the amount of fat.
6. Dumplings for stews:
Use the basic recipe, leaving out the fat.
7. Steamed fruit pudding:
Use the basic recipe to make the dough that incases the fruit.

BREAD MAKING

In beginning the bread lessons, it will be found that there are no new principles to teach. It will, however, be necessary to explain the new means of producing gas which is used in this particular mixture, namely, yeast.

From their lessons on the "Preservation of Food" and "Canning", the pupils are already acquainted with one class of microscopic plants. The little plants, in that case, were a source of great inconvenience to the housekeeper. Yeast may be introduced as another family of one-celled plants, but one which is most useful. Under good conditions these tiny plants will produce a large amount of carbon dioxide gas, provided they are given sufficient time. If, however, the gas be required quickly, soda and acid must be used. For this reason, plain flour mixtures, in which the carbon dioxide is quickly made, are called quick breads, to distinguish them from breads in which yeast is used. Examples of these are baking-powder biscuits, gems, corn-bread, etc.

The use of yeast is the simplest and cheapest way of obtaining carbonic acid gas, and mixtures so made remain moist longer than those in which baking-powder is used.

Throughout the introductory lesson, this fact must be kept prominently before the class, that yeast is a plant and, as such, requires plant conditions. The necessary conditions will be known from the lesson on "Bacteria", so that they have only to be reviewed. The pupils may be told that although they cannot see the plants, they can very plainly see the bubbles of gas which the plants give off when the latter are made active under favourable conditions.

LESSON I

OUTLINE OF LESSONS ON YEAST

1. Description of yeast:

Yeast is a one-celled plant which can be seen only with a microscope. Under good conditions it becomes very active and multiplies rapidly by a process called *budding*. It is used by the housekeeper for the carbonic acid gas it gives off.



Yeast plants magnified

2. Conditions necessary for the activity of yeast:

- (1) Oxygen
- (2) Water
- (3) Food.—This must be sugar, or starch which it will change into sugar. Potato starch is more easily used by yeast than flour starch. It uses also some nitrogenous food and mineral matter.
- (4) Heat.—The yeast plant thrives in a heat of about the same temperature as our bodies. A little extra heat will only make it grow faster; but excessive heat will kill it.

Freezing will not kill the plant, though cold makes yeast inactive.

3. Sources of yeast:

Yeast was first found as *wild yeast* in the air, but now it may be obtained at grocery stores, in three forms:

- (1) Liquid yeast.—The plants are put into a starchy liquid. This will keep only a few days, as the starch sours.
- (2) Dry yeast.—The plants are put into a starchy paste and the mixture is dried. This form will keep for months, because it is perfectly dry but, for the same reason, it takes the plants a long time to become active when used.
- (3) Compressed yeast.—The plants are put into cakes of a starchy mixture and left moist. They will keep only a few days. Good compressed yeast is a pale fawn colour, smells sweet, breaks clean, and crumbles easily.

4. Experiments with yeast:

Make a *yeast garden* by using the plants obtained at the grocery store as follows:

Take half a cup of lukewarm water to give the plants moisture, a teaspoonful of sugar for immediate food, and the same of wheat starch (flour) for a reserve food. Beat the mixture to infold oxygen, and then put in one-quarter cake of yeast plants.

Divide the mixture among a number of test-tubes, so that each group of four pupils has three.

- (1) Place one test-tube in warm water and heat to boiling.
- (2) Place one test-tube in water which feels warm to the hand.

- (3) Place one test-tube in cracked ice and freeze the mixture. Afterwards thaw, and place the same test-tube in lukewarm water.

Observe the results, and compare the amount of gas formed under the different conditions.

LESSON II

PRACTICAL BREAD-MAKING

Ingredients of plain bread:

1. Liquid.—(1) It wets the mixture and causes the ingredients to adhere.
(2) It furnishes steam for a lightening agent.
(3) It allows the gluten to become sticky and elastic.
(4) It furnishes moisture for yeast plants.
2. Yeast.—It gives off carbonic acid gas, which lightens the mixture.
3. Salt. — (1) It gives a flavour.
(2) It retards the growth of the yeast plant.
4. Flour.—(1) It thickens the mixture.
(2) It supplies food for the yeast plant.
(3) It supplies gluten for a framework for the mixture.

Amount of ingredients for one small loaf:

Liquid—1 eup or $\frac{1}{2}$ pt.

Salt— $\frac{1}{2}$ tsp.

Flour—About three times the amount of liquid

Yeast—Amount depends on the time given the bread to rise, as follows:

12 hr. to rise	5 hr. to rise	3 hr. to rise
$\frac{1}{4}$ yeast cake	$\frac{1}{2}$ yeast cake	1 yeast cake

NOTE.—One cake of compressed yeast contains about the same number of yeast plants as one cake of dry yeast or one cup of liquid yeast.

Process in making bread:

- (1) Mixing (stirring, beating, and kneading).—
 - (a) This mixes the ingredients.
 - (b) It incorporates air to aid the yeast plant and to act as a lightening agent.
 - (c) It makes the gluten elastic.
- (2) First rising.—This allows the yeast plants conditions and time to produce carbonic acid gas, until the dough is distended to twice its original size.
- (3) Moulding.—(a) This distributes the gas evenly throughout the loaf.
(b) It shapes the loaf.
- (4) Second rising.—This again allows the yeast plants time to produce gas which will distend the dough to twice its size.
- (5) Baking.—(a) The heat of the oven expands the air and gas in the dough, which causes the gluten framework to distend.
(b) The water changes to steam, which becomes another agent in distending the gluten.

- (c) The starch on the outside of the loaf becomes brown in the dry heat of the oven, while the inside starch is made soluble in the moist heat of the mixture.
- (d) The gluten stiffens into the distended shape.
- (e) The yeast plants are killed.

In this lesson, after deciding on the necessary ingredients, the pupils may be told the amount of each to use for their class work. They should then measure and mix these ingredients and set the dough away for the first rising. While the bread is rising, the kitchen may be put in order and the other steps of the process reasoned out and written.

Other school work must be taken then, until the dough has fully risen, when the process may be completed. After each stage of the process has been carried out, the notes on it may be written.

With the foregoing principles of bread-making in mind, the class should be able to make any bread mixture. Each pupil should have entire responsibility for the process of making one small loaf of plain bread. About half a cup of liquid, mixed with the other necessary ingredients, makes a good-sized loaf for practice. Smaller loaves than this give little chance for manipulation.

In Household Management centres, where the pupils come from other schools for the lesson period only, the process will have to be divided into two lessons. The first lesson may include the first two stages—mixing and first rising—each pupil using small quantities, say for one eighth of a loaf of the ordinary size. At the end of the lesson, they may carry their dough home for completion,

or it may be used by another class which is ready for the later steps of the process.

The second lesson will include the last three steps—moulding, second rising, and baking—and it will be necessary for the teacher to have dough prepared for the moulding stage when the class arrives.

LESSON III

FANCY BREADS

These mixtures are but variations of plain bread. The extra ingredients, such as milk, eggs, butter, spices, sugar, currants, raisins, peel, etc., are added at the most convenient stage of the process.¹

NOTE.—If there is not time to have one fancy bread, such as Parker House rolls or currant bread, made in school, recipes for these may be discussed in class and the work done at home.

THE BREAD-MIXER

1. This utensil mixes and beats the bread by means of a large beater turned with a handle, thus avoiding the use of the hands for this purpose.
2. It does this work with less energy and in a much shorter time than if the hands were used.
3. It can be used only for the first two steps of bread-making, namely, *mixing* and *first rising*.
4. The ingredients must all be put in at once; hence, they must be accurately measured.
5. The amount of ingredients may be learned by calculation from previous bread-making done in the old way, or by using the book of recipes accompanying each mixer.

NOTE.—There are several good kinds of bread-mixers which may be bought in three sizes. Small size makes 1 to 2 loaves and costs \$1.35 (about). Medium size makes 2 to 6 loaves and costs \$2.00 (about). Large size makes 4 to 10 loaves and costs \$2.50 (about).

PASTRY.

Pastry is one of the simplest flour mixtures, and one that has the lowest food value. The intimate blending of butter or lard with the flour envelopes the starch grains with fat, and makes the mixture difficult to digest. The same thing occurs in frying food and in buttering hot toast; so the idea is not a new one to the class.

In introducing the lesson on pastry, this principle of digestion should be reviewed, and it should be made plain that delicate pudding and seasonable fruits are a much better form of dessert.

There are no new principles to teach, but some old ones to impress. The object of the housekeeper should be to make a mixture that is light and one that will fall to pieces easily. To ensure the latter, anything that would toughen the gluten must be avoided.

From the bread lesson, the pupils have learned that working the water into the gluten or much handling of flour after it is wet, makes a mixture firm and tough. In pastry there must be enough gluten to stick the ingredients together, but its elastic quality is undesirable. For the latter reason also, a small amount of water is used.

In the cake mixtures, it was found that the use of fat in the "butter cakes" made the framework tender and easily broken, so in pastry the same means may be employed. Fat of some kind is mixed with the flour to act on the gluten and destroy its toughness.

Air and steam are the only lightening agents commonly used in pastry. Since cold air occupies less room than warm air and admits of more expansion, it is desirable that the mixture be kept very cold. The low temperature also prevents the fat melting; hence, the necessity for the use of cold utensils and materials throughout the process.

OUTLINE OF LESSON ON PASTRY

1. Ingredients:

- (1) Flour, (2) salt, (3) fat, (4) water.

2. Notes on flour:

- (1) Use only pastry flour, which will have a small amount of gluten.
- (2) After the flour is wet, handle the mixture as little as possible, to avoid working the water into the gluten and making it tough.

3. Notes on fat:

- (1) Fat is used to destroy the elasticity of the gluten, so that it will not be tough when cooked.
- (2) Butter, lard, or dripping may be used.
- (3) Lard makes more tender pastry than butter.
- (4) Butter gives the best flavour.
- (5) Half butter and half lard makes a good mixture.
- (6) Layers of fat may be put in between layers of pastry, to separate it into flakes.
- (7) If two fats are used, the softer is cut into the flour, and the harder one laid on the paste and folded in.

4. Notes on water :

- (1) Use the water as cold as possible.
- (2) Use the least amount of water necessary to make the ingredients adhere.

5. Lightening agents used in pastry :

- (1) Air.—(a) This should be as cold as possible.
(b) The air may be folded in, between ' layers of pastry.
- (2) Steam.

6. Kinds of pastry :

- (1) Plain pastry.—In this, one quarter to one third as much fat as flour is used, and it is all " cut in ".
- (2) Flaky pastry.—In this, the same amount of fat is used as in plain pastry, but half of it is " laid on " and folded in.
- (3) Puff pastry.—In this, one half as much fat as flour, up to equal parts of each is used ; one quarter of the fat is cut in, and the remainder is laid on and folded in.

7. Amount of ingredients for plain pastry for one pie :

$1\frac{1}{2}$ eup pastry flour ; $\frac{1}{4}$ tsp. salt ; $\frac{1}{2}$ eup fat (lard and butter) ; ice water.

CHAPTER XII

FORM IV: SENIOR GRADE (Continued)

MEAT

AS MEAT is rather a complex food the teaching of which involves a good many lessons, and as it does not lend itself as well as other foods to the making of dishes useful in practice work, it seems wise to defer the study of it until the Senior Form is reached; the ability and home needs of the pupils should decide this. The season of the year should also be considered. It is wiser to take meat lessons in cold weather because it is then more pleasant to handle and easier to keep. The latter consideration is important in some rural districts, where shops are not convenient.

More preparation is needed for the first meat lesson than for most foods. Some days before, thin bones such as leg or wing bones of fowl, or rib bones of lamb should be soaked in diluted hydrochloric or nitric acid (one part acid to ten of water), to dissolve the mineral substance which gives the bone its rigidity.

Any time before the lesson, a large solid bone of an old animal, such as a knee or hip joint of beef, should be burned for hours to get rid of the connective tissue which holds the mineral substance in shape. This should be carefully done, in order to retain the shape of the bone and to show the porous formation of the mineral substance. If the bone is not blackened by the fire, its white colour will also indicate the lime of which it is formed.

On the day of the lesson it will be necessary to have a piece of meat showing the three parts—fat, bone, and muscle. A lower cut of the round of beef has all these parts, and the muscle is sufficiently tough to show its connective tissue plainly. For the study of fat, a piece of suet is best, as it can be easily picked apart to show its formation.

In examining fat meat and lean meat it is essential that, at least, every two pupils have a piece, as close scrutiny is necessary. One or two samples of bone will suffice for the class.

No definite amount of work can be laid down for any one lesson. The interest and ability of the class must be the guide. In rural schools, the time of each lesson must be comparatively short, though no Household Management teacher should spend more than forty minutes on purely theoretical work without a change of some kind.

The following is an outline of the facts to be considered in this particular study:

LESSON I

1. Names of meat:

- (1) Beef, from the ox or cow. The best meat comes from an animal about four years old.
- (2) Veal, from the calf. It should be at least six weeks old.
- (3) Mutton, from the sheep. Spring lamb is from six to eight weeks old; yearling is one year old.
- (4) Pork, from the pig.
- (5) Fowl, poultry—chicken, turkey, duck, goose.
- (6) Game, wild animals—deer, wild duck, partridge, etc.

2. Parts of meat:

(1) Fat.—(a) Inside fat, around the internal organs, usually called kidney fat, or suet.

(b) Outside fat, next the skin, called caul fat.

(2) Bone, (3) muscle, or lean meat.

3. Composition of fat:

(1) Connective tissue, (2) true fat, (3) water.

Fat should be the first part studied, because it is the simplest tissue and the parts are most plainly seen. Pick the specimen apart, and the tissue that holds it together is found. Its name is easily developed from its use.

The water may be shown by heating pieces of fat in a small saucepan and, when it becomes hot, covering the dish with a cold plate. Remove the plate before it gets heated, and moisture will be condensed on its surface. The presence of water in fat may also be reasoned out by remembering that water enters into the composition of all body tissues.

4. Composition of bone:

(1) Mineral matter (lime), (2) connective tissue, (3) water.

Neither the mineral substance nor the connective tissue in bone can be seen until either one or the other is eliminated.

Strike the fresh bone with a steel knife, and it shows the quality of hardness. Bones are built from food, and the only food substance that is so hard is mineral matter. Show the burned bone, with only the mineral matter left, and let each pupil examine it. Its formation indicates

the spaces which the part burned out of it occupied. Let it fall or crush part of it in the fingers, to show how easily it is broken. Such bones would be no use as a framework to support the body. The bones of very old persons get too much like this, and we are afraid to have such people fall. The burned bone needs something to hold it together—a connective tissue. Such a tissue was in the spaces before the bone was burned.

Show the bone after it has been prepared in an acid solution, with only the connective tissue left. Explain how it was prepared. Bend it to show its pliability. To be of use in the body it needs some substance to make it hard and rigid—the mineral matter which was dissolved out.

NOTE.—This is an excellent time to show the necessity for bone-building mineral in the diet of babies and young children. If they do not get this mineral substance during the growth period, they cannot have hard, rigid bones, and their bodies are apt to become misshapen—bow legs, curved spines, etc. This substance is also necessary for hard, sound teeth.

Draw attention to the fact that the mineral matter in milk and eggs is in solution, and therefore ready to be used by the body. Mineral matter is not in solution in bone, and cannot be dissolved by the digestive process, therefore it is practically of no use as food.

Compare the connective tissue of bone with that of fat, and let the pupils account for the difference in thickness. Lead them to see that connective tissue can be dissolved in hot water, and in this way may be extracted from the mineral part of bone. The housekeeper may do this herself, or she may buy it already extracted, as gelatine.

5. Composition of muscle:

- (1) Connective tissue
- (2) Red part, made up of microscopic tubes holding a red juice. The juice contains:
 - (a) Water
 - (b) Red colour
 - (c) Flavour
 - (d) Muscle albumen—a protein substance similar to egg-white
 - (e) Mineral matter.

It should be made clear that the walls of such tiny tubes can never be thick enough to be tough. Attention

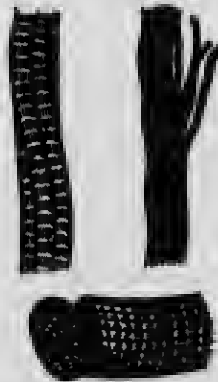

Muscle fibres highly magnified

Bundle of fibres. Tubes of one fibre. Proper carving of fibres—across the grain.

should be called to the real cause of toughness—the thick connective tissue.

NOTE.—Very small pieces of meat will serve for specimens. Tough meat is better, because it shows the connective tissue more plainly. When the muscle is being examined, it should be carefully scraped with a knife, until a layer of connective tissue is laid bare. The red part that is scraped off should be explained, and a drawing should be made to illustrate it.

Minced lean beef should be soaked in a little cold water for at least twenty minutes, to extract the muscle juice for examination. The juice should be strained through a cheesecloth and poured into a glass. It shows nothing but water and a red colour.

In order to find the other substances, pour part of the juice into a small saucepan and heat it gradually until it boils gently. The red colour will disappear, and the albumen which is dissolved in the juice will coagulate and become plainly visible. The pupils will recall that egg-white was affected in the same way by heat, and may be told that this coagulated substance is similar to egg-white, and is called muscle albumen. The odour given off by heating suggests that the flavour is also in the muscle juice, hence the importance of conserving this juice in the cooking process.

Strain the boiled juice to get rid of the coagulated albumen and then examine the liquid that is left. Its colour plainly denotes mineral matter in solution.

LESSON II

6. Meat experiments:

If time permit, the following experiments may be taken. The facts which these experiments prove may, however, be developed in a much shorter time by questioning:

- (1) Cut lean meat into small pieces, cover them with cold water and let them stand. Note the colour of the water.
- (2) Cover a piece of lean meat with boiling water and let it stand. Note the colour of the water.
- (3) Sprinkle a piece of meat with salt. What happens?

- (4) Wrap a piece of meat for a few minutes in ordinary brown wrapping-paper. What happens?
- (5) Simmer a small piece of very tough meat for about an hour and then examine the connective tissue.
- (6) Boil or bake a small piece of very tough meat and then examine the connective tissue.

7. Selection of meat :

- (1) All flesh should be uniform in colour, of a fine grain, and firm and springy to the touch.
- (2) Beef should be bright red in colour, well mottled, and surrounded with fat.
- (3) Mutton should be a dull red, and its fat white, hard, and flaky.
- (4) Lamb is lighter in colour than mutton, and the bone is redder.
- (5) Veal has pinkish-coloured flesh and white fat. Very pale veal is not good.
- (6) Pork should have firm flesh of a pale red colour. The skin should be white and clear, the fat white.
- (7) Poultry:
 - (a) Chickens.—Young chickens have thin, sharp nails; smooth legs; soft, thin skin; and soft cartilage at the end of the breast-bone. Long hairs denote age.
 - (b) Turkeys.—These should be plump, have smooth, dark legs, and soft cartilage.
 - (c) Geese.—These should be plump and have many pin feathers; they should also have pliable bills and soft feet.

8. Care of meat:

- (1) Remove the meat from the wrapping paper as soon as it arrives, to prevent the loss of juices. The butcher should use waxed paper next to the meat.
- (2) Wipe the meat all over with a damp cloth, but do not put it into water.
- (3) Place the meat on an earthen or enamel dish, and set it in a cool place until required.
- (4) Frozen meat should be thawed in a warm room before being cooked.

LESSON III

9. General ways of preparing meat:

- (1) Extracting certain substances.—(a) Soup—substances extracted in water from lean meat, bone, and fat.
 - (b) Beef-tea—substances extracted in water from lean meat.
 - (c) Bouillon—substances extracted in water from lean meat and flavoured with vegetable.
 - (d) Beef juice—juices extracted from lean meat by heat only, or by pressure.
- (2) Retaining all substances.—Roasts, boiling pieces, steaks, chops, cutlets.
- (3) Retaining part and extracting part.—Stews.

10. Notes on tough meat:

- (1) The toughness of meat depends on the thickness of the connective tissue holding the muscle tubes together.

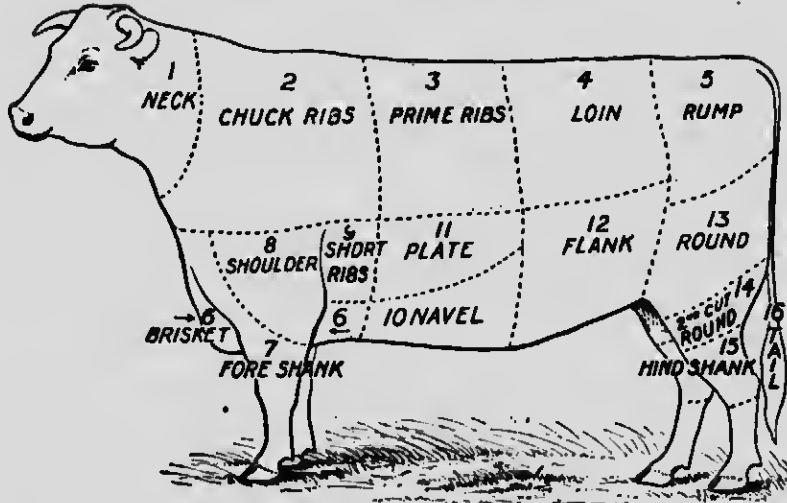

Cuts of beef

1. Neck, stews and soup. 2. Chuck ribs, cheaper roasts. 3. Prime ribs, very good roasts. 4. Loin, best steaks or roasts (sirloin, tenderloin, porterhouse). 5. Rump, roasts and steak. 6. Brisket, stews or corned beef. 7. Fore shank, soup. 8. Shoulder, stews or pot-roasts. 9. Short ribs, stews or cheap roasts. 10. Navel, corned beef. 11. Plate, stews or corned beef. 12. Flank, stews or corned beef. 13. Round, steaks. 14. 2nd cut round, stews and soup. 15. Hind shank, stews and soup. 16. Tail, soup.

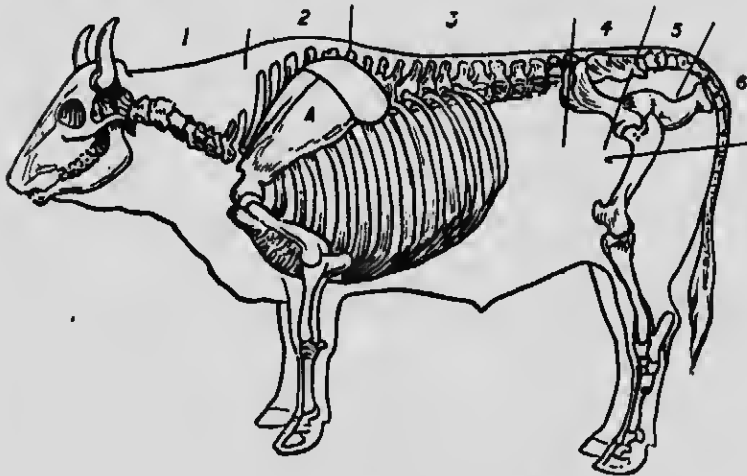

Bony structure

- (2) The connective tissue is made thick and tough by two causes.—
 - (a) Age—in old animals the connective tissue has grown thick.
 - (b) Exercise—in certain parts of the body, where muscles are much used, these muscles must be more firmly bound together, as in the neck and legs, etc.
- (3) Dry heat will harden connective tissue, making it more difficult to cut and chew; therefore tough cuts should not be cooked in dry heat.
- (4) Moist heat will soften and finally dissolve connective tissue, making it easy to cut and chew; therefore tough cuts should be cooked in moist heat.
- (5) Tough meat is more abundant in an animal's body, and is, therefore, cheaper than tender meat.
- (6) Tough meat has richer juices than tender meat and should be used for soup, broth, and beef-tea.

11. Digestibility of meat:

- (1) The less muscle juice is coagulated by heat, the more easily it is digested.
- (2) Because of their close texture, the liver, kidney, and heart of animals are more difficult to digest.
- (3) Mutton and lamb, because of their shorter fibres, are more easily digested than beef.
- (4) Veal is difficult to digest, owing to its stringy fibres.

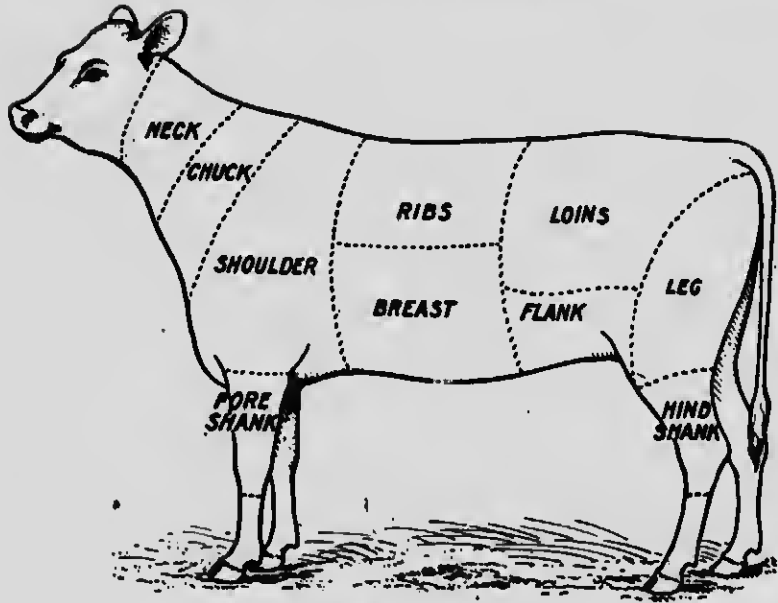

Cuts of veal

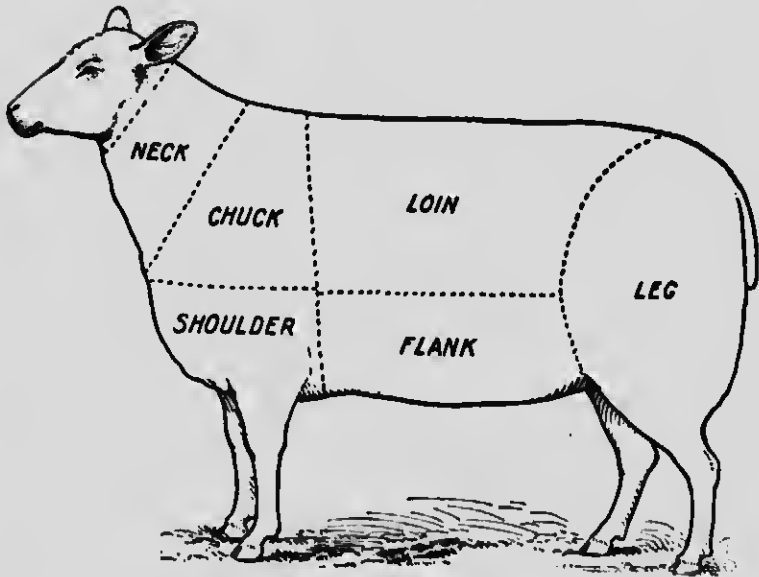

Cuts of lamb

- (5) Pork has a large amount of fat intermingled with its fibres, and is, therefore, difficult to digest.
- (6) Chicken and turkey are easily digested, but goose and duck are indigestible, because of the fat through the muscle fibres.
- (7) Game is easy of digestion.

The practical work, besides the experiments, in connection with the meat lessons, should consist of at least three preparations of this food: (1) the cooking of tender meat, (2) the cooking of tough meat, (3) the making of soup.

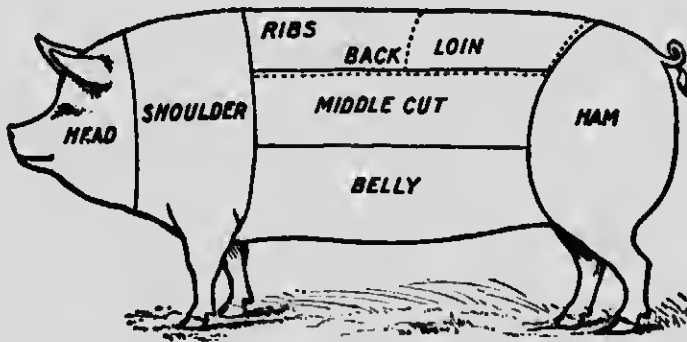

Cuts of pork

The object of each preparation should be made plain, so that the pupils may fully understand what they are trying to accomplish.

1. Object in cooking tender meat:

- (1) To change the flavour and appearance.
- (2) To seal the tubes to keep in the juices.
- (3) To cook the meat without densely coagulating the protein of the muscle juice, so as to keep it digestible.

2. Object in cooking tough meat:
 - (1) To change the flavour and appearance.
 - (2) To soften and partially dissolve the connective tissue, making it easy to cut.
 - (3) To avoid making the muscle juice indigestible.
3. Object in making soup:
 - (1) To extract the connective tissue from the bone.
 - (2) To extract the muscle juice from the tubes.

GENERAL RULES FOR COOKING MEAT

1. Baking:

Place the meat in a very hot oven with pieces of the fat or some dripping in the pan. Baste every ten minutes. Keep the oven very hot for a small roast. For a large roast, check the fire after the first fifteen minutes. Bake fifteen minutes to each pound.

2. Broiling:

(1) Over the coals.—Put the meat between the hot greased wires of a broiler. Place over a very hot, clear fire. Turn the broiler every ten seconds. Beef one inch thick cooks rare in eight minutes.

(2) Pan Broiling.—Heat a frying-pan smoking hot. Lay the meat in flat; turn constantly until seared, then frequently, as in broiling, but do not pierce the muscle part with a fork. Beef one inch thick cooks rare in ten minutes.

3. Boiling:

Cover the meat with boiling water. Boil five minutes. Then simmer until done. Tender meat takes twenty minutes to the pound; tough meat takes from three to five hours.

4. Stewing:

Cut the meat in pieces of a suitable size. Cover with cold water. Bring gradually to the simmering point and simmer until tender, usually three or four hours. Keep the pot closely covered.

5. Beef juice:

Take one pound of steak from the top of the round. Wipe the steak, remove all fat, and cut the lean meat in small pieces. Place in canning jar, and cover; place on a rest in the kettle and surround with cold water. Allow the water to heat slowly, care being taken not to have it reach a higher temperature than 130 degrees. Let stand two hours; strain and press the meat to obtain all the juices. Salt to taste.

NOTE.—These rules may be dictated to the class, as all of the principles which they involve have been previously discussed.

FISH

Since fish is the flesh of sea animals, there will be little new to learn concerning it.

Main points of difference between this flesh and ordinary meat are:

1. Fish is less stimulating and nourishing than meat, as it contains more water and less protein than an equal quantity of lean meat.
2. Oysters, and the class called white-fish, are more easily digested than meat, hence they should be chosen for invalids or those having weak digestions.

Kinds of fish :

1. White-fish.—The fat is stored mostly in the liver, making the flesh easy to digest. Examples: cod, halibut, haddock, white-fish.
2. Oily fish.—The fat is distributed throughout the flesh, making it more difficult to digest. Examples: salmon, herring, mackerel.
3. Shell-fish.—Because of their close fibres, these are difficult to digest, with the exception of oysters. Examples: clams, scallops, and oysters.
4. Crustaceous.—The flesh is tough and hard to digest. Examples: lobsters, crabs.

Selection of fish :

Fresh fish may be recognized by the following:

1. The eyes should be full and bright.
2. The flesh should be firm and elastic.
3. The gills should be bright red.
4. There should be no unpleasant odour.

Cooking of fish :

Fish may be cooked in any way similar to meat. As the flesh of fish contains food substances which are very easily dissolved in water, boiling is not a good method of cooking to choose for this food. Steaming, baking, and frying are more suitable.

GELATINE

A lesson on gelatine naturally follows the lessons on meat and fish. The study of bone and the making of soup have explained the source of this substance, and only a few additional facts are necessary.

The gelatine practice dishes are sure to prove attractive to the class, and the common use of this food in sickness, and in salads and desserts, makes it important that its food value be understood.

1. Source of gelatine:

Gelatine is obtained from the bones, cartilage, and skin of animals. It is the connective tissue dissolved out of these parts.

The housekeeper may obtain it for herself or she may buy it already extracted; both are equally good.

2. Commercial forms:

- (1) Sheet gelatine
- (2) Shredded gelatine
- (3) Granulated gelatine.

3. Properties of gelatine:

- (1) It softens in cold water, but will not dissolve.
- (2) It dissolves in hot water.
- (3) It jellies when cold, if the solution be sufficiently strong.
- (4) Good gelatine has little taste, colour, or odour, and no sediment when dissolved.

4. Steps in dissolving gelatine:

- (1) Put a small amount of cold water or any cold liquid on gelatine, and let it stand until the liquid is absorbed.
- (2) Add a boiling liquid and stir thoroughly until dissolved.

5. Value in the diet:

- (1) Gelatine is a nitrogenous substance, but cannot of itself build tissues, as most protein foods do. When eaten, it will save the tissues already making up the body, hence is called a *protein-sparer*.
- (2) It is very easily digested, and for this reason it gives a pleasant variety to the diet of an invalid.
- (3) It makes an attractive dessert at the end of a substantial meal, without adding much nutriment.

6. Ways of using gelatine:

- (1) It may assist in making soup.
- (2) Any liquid may be used to dissolve this substance to make a plain jelly. Examples: coffee jelly, tomato jelly, wine jelly.
- (3) Plain jelly may be varied as follows:
Allow the plain jelly mixture to cool until it is as thick as cream, and then beat in whipped egg-white, or fruit, or chopped vegetables, and set away until firm. Examples: snow pudding, orange charlotte, vegetable salad.
- (4) Strain off the juice from a can of fruit, heat it, and use it for dissolving the gelatine. When almost set, add the fruit, and set away to become firm.

FROZEN DISHES

A lesson on frozen dishes may be taken at any time, but it seems specially opportune after the gelatine lesson. It may be impossible to make these dishes in school, but the facts of the lesson may be discussed and recipes furnished, after which a Form IV pupil should find no difficulty in carrying out these recipes at home.

Elementary science should be correlated, to explain the use of salt in the freezing process.

VALUE OF FROZEN DISHES

1. They are cooling, refreshing, and nourishing when properly taken; they are not good as a final course at a meal, as cold mixtures reduce the temperature of the stomach and thus retard digestion.
2. They are appetizing in appearance and flavour.
3. They are economical as regards cost of ingredients, fuel, time, and energy.

KINDS OF FROZEN DISHES

1. Water ice.—Fruit juice diluted with water, sweetened and frozen; stirred about every five minutes while freezing.
2. Frappé.—Water ice frozen to the consistency of mush; in freezing, equal parts of ice and salt are used to make the mixture granular.
3. Sherbet.—Water ice to which is added a small quantity of dissolved gelatine or beaten egg-white; stirred constantly while freezing.
4. Ice cream.—Thin cream, sweetened, flavoured, and frozen; stirred constantly while freezing.

5. Plain ice cream.—Same as ice cream with custard added.
6. Mousse.—Thick cream, beaten until stiff, sweetened, flavoured, placed in a mould, packed in ice and salt (two parts ice to one part salt), and allowed to stand three hours. A small quantity of dissolved gelatine may be added to the mixture.

PRACTICAL WORK

1. Freezing:

- (1) Scald the can and dasher and cool just before using.
- (2) See that all parts of the freezer are properly adjusted.
- (3) Empty the mixture into the can; never fill the can more than three-quarters full, to allow for expansion when freezing.
- (4) Prepare ice by chipping finely or by crushing in a canvas bag by means of a mallet.
- (5) Allow three measures of ice to one of coarse rock salt and pack this mixture solidly around the can.
- (6) Turn the crank slowly and steadily until the mixture begins to freeze, then turn more rapidly until frozen.
- (7) Add more ice and salt as needed, but do not draw off the salt water except to keep it from getting inside the can.

2. Packing:

- (1) When the mixture is frozen, draw off the water, remove the dasher, and pack the contents of the can down solidly with a spoon.
- (2) Replace the cover, using a cork for the opening, then repack in ice and salt (four parts ice to one part salt).
- (3) Cover with newspapers, blanket, or carpet, and let it stand for at least one hour before serving.

3. Moulding:

- (1) Wet the mould and pack the frozen mixture in solidly.
- (2) Place the cover on the mould and bind strips of greased cotton or waxed paper around all the crevices.
- (3) Imbed the mould in ice and salt (four parts ice to one part salt).
- (4) Wrap a cloth wrung from hot water around the mould for an instant, before removing the mixture.

PLANNING AND PREPARATION OF MEALS

The food work of the previous Forms, from constant reference and use, should be so well known that it may be reviewed in one lesson, under the following heads:

1. Uses of food
2. Necessary substances in food
3. Composition of the common foods—milk, eggs, meat, vegetables, fruit, seeds
4. General sources of each food substance.

After the review, the class may be asked to prepare menus for one day's meals, keeping in mind the following:

1. Daily balance of food substances
2. Appetizing appearance and flavour of the food
3. Economy of time, labour, and money in providing the food.

The preparation of menus may be continued, even while other work is being studied, until the teacher feels satisfied with the ability of the class to prepare menus intelligently.

The planning of menus should, if time permit, be extended to actual practice in preparing and serving the meals called for by some of the menus. In this Form there should be a limit set to the number of people served and the cost of the food.

Since breakfast and luncheon were prepared in the Junior Form, a dinner should be taken in this. The entire responsibility of the meal should be given to the pupils, each being appointed to perform definite duties. The teacher may advise while the class is planning the work, but not assist while it is being carried out.

Each member of the class may be asked to prepare a menu to suit the special conditions which have been made as to number and cost. These may be planned at home and brought to the teacher for criticism. At the first lesson, three or four of the best may be written on the black-board for comparison and choice.

When the selection is made, members of the class should be chosen for the following duties: (1) marketing, (2) preparation of food, (3) laying the table, (4) serving, (5) representing members of the family to eat the meal.

NOTE.—To prevent any suspicion of favouritism, the duties may be written on slips of paper and the pupils allowed to draw these.

At the second lesson the meal will be prepared, served, and eaten. In schools lacking an equipment, the meal may be planned and selected in the same way as above, but the entire responsibility of carrying it out must rest on one pupil, as it will be necessary for each to prepare and serve it in her own home.

CHAPTER XIII

FORM IV: SENIOR GRADE (Continued)

INFANT FEEDING

THIS subject is more suitable for older students than for those attending the public and separate schools, but, because of its importance and the fact that many girls never go beyond the Entrance class, it is deemed wise to present, to the pupils of Form IV, the main facts relating to the feeding of infants. Each teacher must however use her judgment in the choice of these facts for her class and in the method of presenting them. The instruction given may include the following ideas:

The natural food of an infant is its mother's milk, and too much stress cannot be placed on the necessity of nursing by the mother.

Even if the mother has but a small supply, the baby should not be weaned; the supply should be supplemented by modified milk. In the rare cases where a mother cannot nurse her baby, a physician should prescribe the food. In such a case the best substitute is cow's milk.

If cow's milk be used, it will have to be changed or "modified" to make it as far as possible like mother's milk. Cow's milk differs in the following respects: It has (1) less water and therefore more solids; (2) a larger proportion of protein and mineral compounds; (3) less sugar; (4) a different combination of fats.

Cow's milk cannot be made like mother's milk, but it is better food for a little baby if cream, milk sugar, and barley water, are added in certain proportions, varying according to the age of the child.

RECIPE FOR MODIFIED MILK

Milk	7 ounces
Milk sugar	$\frac{1}{2}$ ounce
Cream (18%)	1 ounce, if ordinary milk be used or $\frac{1}{4}$ ounce if Jersey milk be used.
Barley water	Dilute with barley water to make 20 ounces for the first two or three weeks, then reduce to 16 ounces up to about three months of age. The volume may then be reduced to 14 ounces, and at five or six months to 12 ounces.

Mixed milk, and not one cow's milk, should be used, for the reason that a better average of milk is secured from several cows than from one. The supply should be fresh and clean. To make sure of the latter, scrupulous care should be given to the cleanliness of the cows' bodies and stables, the utensils, and the clothing and hands of the milkers. If there is any doubt of the cleanliness, the milk should be pasteurized. This pasteurization greatly reduces the bacterial life in the milk by a temperature which does not change its composition and digestibility, as is the case in sterilizing it.

DIRECTIONS FOR PASTEURIZING MILK

Sterilize bottles as for canning. Nearly fill the bottles with milk and cork them with absorbent cotton which has been sterilized (by being baked a delicate brown). Place the bottles on a rest in a deep kettle and surround them with cold water as high as the milk. Heat the water gradually to 155 degrees Fahrenheit, or until tiny bubbles show in the milk next the glass. Remove the kettle and contents to where the temperature of the milk will remain

the same for half an hour. Then cool the milk quickly by putting the bottles first in lukewarm water and then in cold water. Keep in a cool place and do not remove the cotton until ready to use. Pasteurized milk should not be kept more than a couple of days.

The utmost care and cleanliness should be observed in preparing the infant's food. All utensils which come in contact with the food should be sterilized each time they are used. Bottles with rubber tubes should *never* be used, as they cannot be thoroughly cleaned. The bottle should be plain and graduated without a neck, and the nipple should admit of being turned inside out.

CARE OF BOTTLES

After the nursing, the bottles should at once be rinsed with cold water. Later, the bottles and nipples should be carefully washed in hot, soapy water, then rinsed in clear, hot water. They should then be sterilized by boiling in water for twenty minutes, after which they may be placed in borie acid solution (1 tsp. to 1 qt. water), or the bottles may be emptied and plugged with sterilized absorbent cotton until again required.

CARE OF FOOD

It saves much time to make sufficient food to last for twenty-four hours. This may be put into a large bottle, or what is better, into the several nursing bottles, and each plugged with sterilized absorbent cotton. After cooling, the bottles should be put on the ice or in some cool place until required. Where there is no refrigerator, an ice-box made on the principle of the home-made fireless cooker will

do excellent service. When the food is to be used, it should be warmed slightly above body heat by placing the bottle in warm water.

The following table is taken from *The Care and Feeding of Children* by L. Emmet Holt, M.D., of New York.

SCHEDULE FOR FEEDING A HEALTHY CHILD
DURING THE FIRST YEAR

Age	Interval between meals by day	Night feedings (6 p.m. to 6 a.m.)	Number of feedings in 24 hours	Quantity for one feeding	Quantity for 24 hours
	Hours			Ounces	Ounces
2nd to 7th day	3	2	7	1 -2	7-14
2nd and 3rd weeks.	3	2	7	2 -3½	14-24
4th to 6th week	3	2	7	3 -4	21-28
7th week to 3 mos.	3	2	7	3½-5	25-35
3 to 5 months	3	1	6	4½-6	27-36
5 to 7 months	3	1	6	5½-6½	33-39
7 to 12 months	4	..	5	7 -8½	35-43

CHAPTER XIV

FORM IV: SENIOR GRADE (Continued)

HOUSEHOLD SANITATION

As the principles of sanitation are based on a knowledge of bacteria, the facts concerning these microscopic plants, which were taught in the lesson on the "Preservation of Food", have only to be reviewed and extended.

The following topics should be quickly reviewed:

1. Description of bacteria
2. Occurrence of bacteria
3. Favourable conditions for bacteria
4. Multiplication of bacteria
5. Useful bacteria
6. Harmful bacteria.

It is with the harmful bacteria that our lesson on sanitation deals. The pupils already know that some kinds belonging to this class cause the decay of food, and now they are ready to be told that other harmful kinds of microscopic plants gain entrance to our bodies and cause disease. Concerning these, the following outline of facts should be taken:

1. MEANS OF BACTERIA ENTERING THE BODY

- (1) Through the respiratory organs
- (2) Through the digestive tract
- (3) Through the broken skin.

2. COMMON DISEASE-PRODUCING BACTERIA

- (1) Those entering the respiratory organs.—Mumps, scarlet fever, whooping-cough, diphtheria, measles, pneumonia
- (2) Those entering the digestive tract.—Typhoid, cholera, tuberculosis
- (3) Those coming through cuts, etc.—Skin diseases like ringworm, blood poisoning, lockjaw (tetanus).

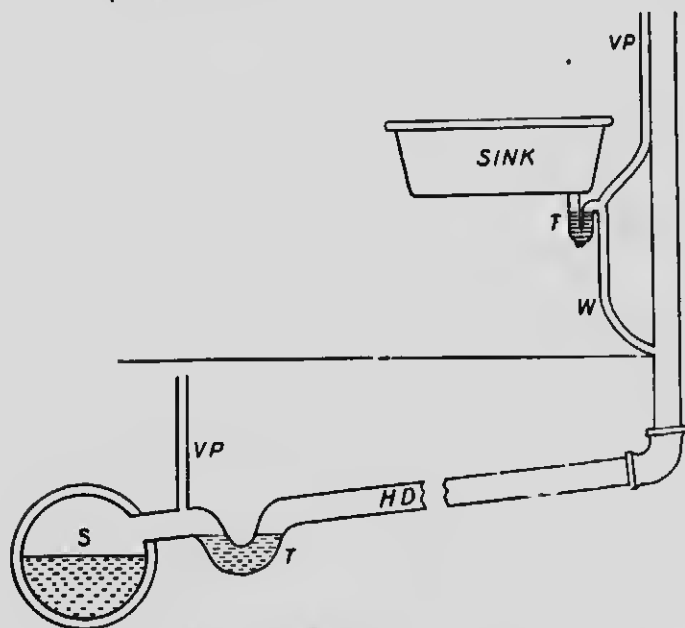

Sink and sewer connection

T—Trap. W—Waste pipe. H.D.—House drain. S.—Sewer.

If housekeepers do not exercise care, these disease-producing bacteria may enter the home, and finding there all the conditions which they require, they will multiply, and become a menace to the family.

3. METHODS OF SANITATION

Since bacteria are too small to be seen, it is very hard to deal with them. The housekeeper has the following ways of protecting the household:

- (1) By having all drain pipes trapped:
- (2) By keeping the house free from lodging places for bacteria:
 - (a) Keep the house clean and free of dust.
 - (b) Wash garbage pails and sinks daily and scald them and drain pipes at least once a week.
 - (c) Keep the refrigerators, cupboards, and receptacles for food clean, and allow no spoiled food to remain in them.
 - (d) Wash and sterilize the soiled clothing once a week.
 - (e) Keep the cellar well aired and clean; allow no decaying material to remain in it.
 - (f) Keep the door-yards clean; allow no scraps of food, cleaning water, or sweepings to be thrown near the house.
- (3) By keeping the supply of food from disease-producing bacteria:
 - (a) Use screens to keep out flies, which transfer bacteria from their bodies to food.
 - (b) Wash fresh fruit and vegetables before using.
 - (c) Boil for twenty minutes water of doubtful purity.
- (4) By keeping the bodies of the family strong and healthy, so that if bacteria gain an entrance they will be resisted and overcome:

- (a) Provide well-balanced, nutritious food.
- (b) Supply suitable clothing to protect the body.
- (c) See that there is an abundant supply of fresh air, night and day.

4. DISPOSAL OF WASTE IN VILLAGES AND RURAL DISTRICTS

- (1) Burn all combustible material.
- (2) Bury tins, broken dishes, etc.
- (3) Feed refuse food to animals or empty it into a pit dug for the purpose, and cover with a layer of earth from time to time.
- (4) Throw slop water at a distance from the house and well, and plant stalky growths like sunflowers, which absorb the waste.

5. METHODS OF DISINFECTING

Where bacterial disease is known to exist, the utmost care should be taken to subject everything that has come in contact with the patient to a process which will kill the disease-producing plants. Only two ways of doing this are known:

- (1) Subject the bacteria to extreme heat which will kill them—
 - (a) Burn everything that can be burned.
 - (b) Boil bed and body linen.
 - (c) Scald dishes.
 - (d) Scald or bake utensils.
- (2) Use chemicals to destroy the germs—
 - (a) Use chemical solutions to wash surfaces, materials, or utensils.

- (b) Seal the rooms and burn chemicals to produce vapours which will destroy bacteria.

NOTE.—Directions for the use of chemicals are given under the lesson on "Home Nursing".

HOME NURSING

This part of the work does not require a special equipment, though it is an advantage to have one. An ingenious teacher, with the co-operation of her pupils, will invent plans for providing whatever is necessary for demonstration. Pupils living near the school can supply many of the needed materials.

A doll and doll's bed may be used to teach bed making and the changing of bed-clothing while the patient is in bed. The doll may also be used to illustrate the method of giving a patient a bath in bed and of changing the body clothing, if such information is desired.

In some cases, a manual training pupil might construct the bed, and the sewing class the mattress, bed-clothing, and doll's underwear. If this were the property of the school, the girls could take turns in making the bed every day and in laundering the clothing at home once a week.

It is desirable that the instruction in home nursing be given in two lessons. These may be outlined as follows:

LESSON I

THE SICK ROOM

1. Location.—The room should be on the sunny side of the house and be as large and airy as possible. The top floor is quieter, but necessitates many steps.

2. Furniture.—All furniture should admit of easy cleaning. Small rugs are better than a carpet, as they can be easily removed for cleaning. In infectious diseases, only bare necessities should be kept in the room.

The bed should be single and placed so as to be accessible from both sides. It should be high enough to prevent the nurse stooping. The bed-clothing should be of light weight and washable.

A bedside table should be provided, also a couch for the nurse. A screen will be found useful to prevent draughts and to shade the light.

3. Ventilation.—A thermometer should be used, and the temperature kept at 65 degrees to 68 degrees, or, in special diseases, according to the doctor's orders.

An abundant supply of fresh air should be provided day and night. To secure this, there must be two openings, one to admit pure, fresh air, and the other to let out the impure air. These openings are preferably on opposite sides of the room and at different heights. If there is only one window, it should be made to open at both top and bottom. In extreme cases, an adjoining room may be aired and, after the fresh air is warm, it may be admitted to the sick room.

4. Care.—The room should be kept very clean and neat. All cleaning should be quietly done, so as not to annoy or disturb the patient. The floor, wood-work, and furniture should be dusted with a damp cloth.

Flowers should be removed at night and should have fresh water daily.

No food or medicine should be left in the room. Soiled dishes or clothing should be removed as soon as possible and, in cases of infectious diseases, placed in water, containing a disinfectant.

All excreta should be taken away immediately and, if necessary, disinfected before being emptied.

METHOD OF DISINFECTING

1. Dishes or clothing.—(1) Make a solution using one part of carbolic acid to twenty parts of water (six teaspoonfuls to a pint of water) and let it stand for half an hour. Soak the articles in this for two hours. (2) Use formalin according to directions. (3) Use bichloride tablets according to directions. (This turns clothes yellow.)

NOTE.—These solutions must be renewed every twenty-four hours, if exposed to the air.

2. Excreta.—Cover the excreta with one of the above solutions and allow it to stand for half an hour before emptying.

LESSON II

THE PATIENT

1. Care of the bed.—The bed of a sick person should be kept specially clean and fresh. The linen should be changed every day, or oftener if soiled. Where the supply of linen is limited, or where there is pressure of work, a good airing and sunning may occasionally take the place of laundering.

In making the bed, it should be kept in mind that the under sheet requires unusual tucking in at

the head, to prevent its slipping down and becoming wrinkled. The upper sheet should receive extra attention at the foot, as it is apt to pull up.

When changing the sheets with the patient in bed, work as deftly and quietly as possible. Have the clean sheets warmed and the room comfortably heated. Begin with the under sheet as follows:

- (1) To change the under sheet.—Turn the patient over on the side away from you and fold the soiled sheet in flat folds close to the body. Lay the clean sheet on the side of the bed near you, tuck it in, and fold half of it against the roll of soiled sheet, so that both can be slipped under the body at once. Turn the patient back to the opposite side, on the clean sheet, pull out the soiled sheet, and tuck the clean one smoothly in place.
- (2) To change the upper sheet.—Loosen all the clothes at the foot of the bed. Spread a clean sheet and blanket, wrong side up, on top of the other bedclothes. Pin the clean clothes at the head of the bed or get the patient to hold them. Gradually slip down and draw out the soiled sheet and blanket. Tuck all in place.

2. Care of the diet.—Recovery from sickness in many cases depends more upon the right kind of food than on medicine. The importance of proper diet should have been impressed on the minds of the pupils by their lessons on food, in the Junior Grade of Form IV. They may now be shown that, in sickness, the

responsibility of the choice of food is transferred from the patient to the doctor or nurse. Hence it is most important that a person acting as nurse should be trained in food values and proper methods of cooking. She should also be capable of exercising daintiness and artistic skill in serving, so that the appearance of the food may tempt the patient to eat it.



Invalid's tray

It should not be necessary to review the comparative values of the well-known foods or the best methods of applying heat to make and keep these foods digestible; it may be taken for granted that the class remembers these facts. The time may be more profitably used in naming and discussing special dishes which are included in invalid cookery. Recipes may be given for any of these which the pupils desire or the teacher chooses, and one or two of the dishes which require very little time to make, may be prepared.

For the sake of convenience, diets for the sick may be classified as *Milk*, *Liquid*, *Light*, and *Full*. These terms are an easy way of indicating a certain range of foods.

Milk Diet.—Milk, butter-milk, koumyss, kephyr.

NOTE.—Lime-water may be given with sweet milk, one part to three of milk.

Liquid Diet.—Milk diet, beef juice or beef-tea, broths, gruels, and sometimes jelly.

Light Diet.—Soup, white meat of fowl, white fish, oysters, soft-cooked eggs, custard, milk puddings, fruit, gelatine jellies.

Full Diet.—Any food that is not particularly hard to digest.

NOTE.—Plenty of water should be given in all diets.

POULTICES

A poultice is used to reduce inflammation and should be as large as the affected part.

The kinds in ordinary use are:

1. Mustard poultice, used as a counter irritant.
2. Linseed, bread, or potato poultice, used to soothe.

Directions for a mustard poultice:

1. For a very strong poultice, mix pure mustard to a paste with warm water; spread on a piece of cheesecloth or muslin, leaving a margin of an inch; fold over the margin, and cover with thicker cotton or paper.

2. For milder poultices use flour to reduce the mustard as follows:

- (1) 1 part flour to 1 part mustard
- (2) 2 parts flour to 1 part mustard
- (3) 3 parts flour to 1 part mustard.

Directions for linseed, bread, or potato poultices:

Use boiling water to mix the above to the consistency of thick porridge, and spread as in the mustard poultice, excepting that the layer of poultice is made much thicker, in order to retain the moisture and heat.

FOMENTATIONS

These are much the same in their effects as poultices, but are sometimes more convenient.

Directions for fomentations:

Spread a towel over a large basin, place a flannel in the towel and pour boiling hot water over it. Fold the towel over the flannel, gather the dry ends of the towel in either hand, and wring. Carry to the patient, shake out the flannel, and apply.

BIBLIOGRAPHY

THE FOLLOWING books are recommended for reference, the more useful being marked with an asterisk:

THE HOME

- Furnishing of a Modest Home. Daniels, \$1.00. Atkinson, Mentzner & Co., New York.
- Home Decoration. Priestman, \$1.50. Whitcomb & Barrows, Boston.
- *Care of a House. Clark, \$1.50. The Macmillan Company of Canada, Ltd., Toronto.

SCIENCE AND SANITATION

- *Elementary Household Chemistry. Snell, \$1.25. The Macmillan Company of Canada, Ltd., Toronto.
- Chemistry of Cooking and Cleaning. Richards and Elliott, \$1.00. Whitcomb & Barrows, Boston.
- Fuels of the Household. White, 75c. Whiteomh & Barrows, Boston.
- *Story of Germ Life. Conn, 35c. Whitcomb & Barrows, Boston.
- *Household Foes. Ravenhill, 75c. McClelland, Goodchild & Stewart, Ltd., Toronto.
- *The Source, Chemistry, and Use of Food Products. Bailey, \$1.75. Blakiston, Son & Co., Philadelphia.

FOOD AND DIETETICS

- *Food Products. Sherman, \$2.00. The Macmillan Company of Canada, Ltd., Toronto.
- Food Materials and their Adulterations. Richards, \$1.00. Whitcomb & Barrows, Boston.

- *Food and Dietetics. Hutchison, \$3.00. Wm. Wood & Co., 51 Fifth Avenue, New York, N.Y.
- Principles of Human Nutrition. Jordan, \$1.75. The Macmillan Company of Canada, Ltd., Toronto.
- *Care and Feeding of Children. Dr. Emmet Holt, 75c. D. Appleton, N.Y. (McAinsh, Toronto)
- Care of the Baby. Dr. J. P. C. Griffith, \$1.50. W. B. Saunders & Co., Philadelphia.
- A Little Talk about the Baby. Helen MacMurchy, M.D. Free. The Provincial Board of Health, Toronto.
- Farmers' Bulletins. 5c each. Department of Agriculture, Washington, U.S.A.

COOKING AND SERVING

- *Boston Cooking School Cook Book. Farmer, \$2.00. McClelland, Goodchild & Stewart, Ltd., Toronto.
- *Diet in Disease. Pattee, \$1.00. Whitcomb & Barrows, Boston.
- Elements of the Theory and Practice of Cookery. Williams & Fisher. The Macmillan Co. of Canada, Ltd., Toronto.
- *Girls' Home Manual. Annie B. Juniper. British Columbia Government, Victoria, B.C.
- Practical Cooking and Serving. Hill, \$1.50. McClelland, Goodchild & Stewart, Ltd., Toronto.

LAUNDRY WORK

- The Art and Practice of Laundry Work.. Rankin, 1s. 6d. Blackie & Son, Limited, London, England.
- The Expert Cleaner. Seaman, 75c. McClelland, Goodchild & Stewart, Ltd., Toronto.
- *Bulletins on "The Laundry". 5c each. Department of Home Economics, Cornell University, Ithaca, N.Y.

HOME NURSING

- Emergencies. Gulick, 40c. Ginn & Company, New York.
- *Home Nursing. Harrison, \$1.00. The Macmillan Co. of Canada, Ltd, Toronto.
- Hints and Helps for Home Nursing and Hygiene. Cosgrave, 40c. St. John Ambulance Assn., Toronto.

ECONOMICS

- Home Problems from a New Standpoint. Hunt, \$1.00. Whitcomb & Barrows, Boston.
- *Household Management. Terrill. American School of Home Economics, Chicago, Ill.
- *The New Housekeeping. Frederick, \$1.00. Musson Book Co., Toronto.

MAGAZINES

- Good Housekeeping Magazine. \$2.00 per year. 119 West Fortieth St., New York.
- *The Journal of Home Economics. \$3.00 per year. 525 West 120th St., New York.

