

Technical and Bibliographic Notes / Notes techniques et bibliographiques

The Institute has attempted to obtain the best original copy available for filming. Features of this copy which may be bibliographically unique, which may alter any of the images in the reproduction, or which may significantly change the usual method of filming, are checked below.

L'Institut a microfilmé le meilleur exemplaire qu'il lui a été possible de se procurer. Les détails de cet exemplaire qui sont peut-être uniques du point de vue bibliographique, qui peuvent modifier une image reproduite, ou qui peuvent exiger une modification dans la méthode normale de filmage sont indiqués ci-dessous.

- Coloured covers/  
Couverture de couleur
- Covers damaged/  
Couverture endommagée
- Covers restored and/or laminated/  
Couverture restaurée et/ou pelliculée
- Cover title missing/  
Le titre de couverture manque
- Coloured maps/  
Cartes géographiques en couleur
- Coloured ink (i.e. other than blue or black)/  
Encre de couleur (i.e. autre que bleue ou noire)
- Coloured plates and/or illustrations/  
Planches et/ou illustrations en couleur
- Bound with other material/  
Relié avec d'autres documents
- Tight binding may cause shadows or distortion along interior margin/  
La reliure serrée peut causer de l'ombre ou de la distorsion le long de la marge intérieure
- Blank leaves added during restoration may appear within the text. Whenever possible, these have been omitted from filming/  
Il se peut que certaines pages blanches ajoutées lors d'une restauration apparaissent dans le texte, mais, lorsque cela était possible, ces pages n'ont pas été filmées.
- Additional comments:/  
Commentaires supplémentaires:

- Coloured pages/  
Pages de couleur
- Pages damaged/  
Pages endommagées
- Pages restored and/or laminated/  
Pages restaurées et/ou pelliculées
- Pages discoloured, stained or foxed/  
Pages décolorées, tachetées ou piquées
- Pages detached/  
Pages détachées
- Showthrough/  
Transparence
- Quality of print varies/  
Qualité inégale de l'impression
- Continuous pagination/  
Pagination continue
- Includes index(es)/  
Comprend un (des) index

Title on header taken from:/  
Le titre de l'en-tête provient:

- Title page of issue/  
Page de titre de la livraison
- Caption of issue/  
Titre de départ de la livraison
- Masthead/  
Générique (périodiques) de la livraison

This item is filmed at the reduction ratio checked below/  
Ce document est filmé au taux de réduction indiqué ci-dessous.

10X	12X	14X	16X	18X	20X	22X	24X	26X	28X	30X	32X
										✓	

19th YEAR OF PUBLICATION.

32/623  
17

# THE CANADIAN MINING REVIEW

Established 1882

AN ILLUSTRATED MONTHLY JOURNAL OF INFORMATION FOR MINE MANAGERS AND MINING ENGINEERS.

---

THE OLDEST AND ONLY OFFICIAL MINING PUBLICATION IN THE  
DOMINION OF CANADA.

---

EDITED AND PUBLISHED BY

B. T. A. BELL,

Secretary of The Canadian Mining Institute,  
Secretary of The General Mining Association of Quebec,  
Secretary of The Ontario Mining Protective Association,  
Hon. Secretary of The Mining Society of Nova Scotia.  
Secretary, Canadian Mica Miners' Association.

---

1900.

---

VOLUME XIX.

---

EDITORIAL OFFICES:  
SLATER BUILDING, OTTAWA, CANADA.

# INDEX TO VOLUME XIX.

	PAGE.		PAGE.
Acadia Coal Co. ....	34-38-120	Fuel Question, The. ....	239
Acetylene Industry, Present Condition of. ....	148	Gob Fires. ....	24
Amalgamated Copper Plates and Electrolysis. ....	121	Locomotives, Use and Abuse of. ....	17
American Institute of Mining Engineers, Canadian Meeting. ....	160-193	Mining Practice. ....	244
Anglo-Canadian Gold Estates, Ltd. ....	257	Notes. ....	67-135-153-170-214-243-267
Artic Slope Hydraulic. ....	279	Nova Scotia's Non-Caking Coals. ....	108-117
<b>ASBESTOS:</b>		Nova Scotia, 1899. ....	34-35
Exports of from Canada. ....	121	Shaft Sinking under Difficulties. ....	122
Mining at Thetford, Que. ....	194	Spontaneous Ignition of in Ships. ....	245
Mining in Quebec. ....	180-194	St. Lawrence Deliveries, 1900. ....	268
United States Output of. ....	5	Wedge for Coal Getting, A New. ....	208
Asbestos and Asbestic, Ltd. ....	24-235	Winding from Great Depths. ....	182
Atlas Arsenic Mining Co. ....	107-142	Columbia and Kootenay Mine (B.C.). ....	23
Atlin Gold District (B.C.). ....	69-88	Company Notes. ....	59-96-257-279
Bad Mine (Ont.). ....	99	Company Report, A Model. ....	239
Bag Bay Gold District (Ont.). ....	36	Compressor, Largest in Canada. ....	53
Bedford Iron Mine (Ont.). ....	140	Concentration by Oil. ....	267
Bell Island Iron Mines (Newfoundland). ....	205-264	Concentration, Present Tendencies in. ....	264
Bell's Asbestos Co., Ltd. ....	120	Consolidated Cariboo Hydraulic. ....	59-147-188-256
Belleville Prov. Assay Office. ....	46-143	<b>COPPER:</b>	
Blast Furnaces in America. ....	238	In 1899. ....	123
Blue Archibald. ....	167	In Steel. ....	24
Blue Bell (Rossland) Mine, Ltd. ....	265	Mining in British Columbia. ....	127
Blue Nose Gold Mining Co. ....	144	Mining in Ontario. ....	46-213
Boerth Gold Mine (Ont.). ....	142	Cordova Exploration Co., Ltd. ....	106-142
Boring Appliance, A. ....	122	Corundum Deposits of Ontario. ....	87-143
Bosun Mines, Limited. ....	58-120	Costs, Mining. ....	111
<b>BRITISH COLUMBIA:</b>		Crow's Nest Pass Coal Co. ....	56
Atlin Gold District. ....	69-88	Cumbe: land Ry. and Coal Co. ....	35-121
Bridge River Gold District. ....	192	Cyanide Solutions, Selective Action of. ....	44
Boundary District. ....	8-185	Detaching Hook, A New. ....	270
Coal Trade of in 1899. ....	35	Diamond Gold Claim (Ont.). ....	142
Copper Mining. ....	127	Diamonds in Ontario. ....	86
Gold Dredging in. ....	181	Dominion Coal Co. ....	34-121-139-195-198-245-246
Lardeau District. ....	23-58 97-119-237-278	Dominion Copper Mining Co. ....	280
Mining Progress of in 1899. ....	55-127-151	Dominion Iron and Steel Co. ....	194-197-206-245
Nelson District. ....	8	Dominion Mining and Developing Agency, Ltd. ....	25
Rossland District. ....	7 22-131-137-179-237-278	Dredging for Gold in B.C. ....	181
British Columbia Bullion Extraction Co., Ltd. ....	131	Dredging for Gold, Notes on. ....	226-227
British Columbia Copper Co. ....	256	Dufferin Iron Mine (Ont.). ....	140
Boundary Creek District (B.C.). ....	8-185	Electric Blasting Cartridge. ....	208
Bounties on Minerals (Dominion). ....	35	Electro Chemistry and Electro Metallurgy. ....	76
Bridge River Gold District (B.C.). ....	192	Electro Magnet in Boring. ....	122
Brookfield Mining Co. ....	142	Electricity in Cyaniding. ....	32
Bruce Copper Mines of Ontario, Ltd. ....	106	Evening Star Claim (B.C.). ....	22-180-279
Budden, H. A., the late. ....	45	Explosives, Careless Handling of. ....	46
Bullion No. II Claim (Ont.). ....	7	Explosives, A Manual on. ....	245
Bully Boy Gold Claim (Ont.). ....	41	<b>FAN, A Combined Exhaust and Blast</b> ....	108-118
Calabogie Iron Mine (Ont.). ....	140	Forty-Third Mining and Milling Co. ....	280
California Gold Mine (B.C.). ....	122	Fowler, S. S. (Portrait). ....	103
Canada Coals and Ry. Co. ....	35	Foxton Mica Mine. ....	140
Canada Corundum Co. ....	256	Frasch Copper Nickel Process. ....	245
Canada Iron Furnace Co. ....	161-213-272	Frontenac District (Ont.). ....	184
Canada Petroleum Co., Ltd. ....	111	Fuel Question, The. ....	239
Canadian Copper Co. ....	129-257	<b>Gas, Oil Fields (Que.).</b> ....	111
Canadian Gold Fields, Ltd. ....	97-107-142-160	General Mining Association, Ltd. ....	34
Canadian Mining Institute. ....	5-36-54-85-150-263	Geological Survey of Canada. ....	5
Canadian Pacific Smelting Works. ....	56	Giant Mine (B.C.). ....	22
Canadian Peat Fuel Co. ....	3	Gibson, Mr. T. W. ....	112
Canals and our Metallurgical Industry. ....	62	Glen Almond Mica and Mining Co. ....	235
Cape Breton Coal Co. ....	35	Golden Star Mining and Exploration Co. ....	31-264
Cape Breton, Coal Mining in. ....	118	Golden Twins, Ltd. ....	172
Cape Breton, The Prosperity of. ....	187	Gold Estates Co. ....	58
Carbonaceous System of Eastern Canada. ....	152	<b>GOLD MINING AND MILLING</b>	
Cast-Iron, Methods of Testing. ....	201	Amalgam Plates and Electrolysis. ....	121
Centre Star Mine (B.C.). ....	23-179-278-259	British Columbia, 1899. ....	127
Chlorination at Mount Morgan. ....	2	Centrifugal Sluicing. ....	224
Chromite Shipments, 1899. ....	5	Chlorination at Mount Morgan. ....	3
Civil Engineers' Bill. ....	55	Concentration, Present Tendencies in. ....	265
Clergue, F. H., His Work for Ontario. ....	6	Concentration of Sulphides. ....	4
<b>COAL MINING AND TRADE:</b>		Cyanide Solutions, Selective Action of. ....	44
Arrested Rust and Decay. ....	129	Deep Level Shafts on the Rand. ....	201
British Columbia. ....	35-127	Dredging in British Columbia. ....	180
Cape Breton. ....	118-187	Dredging, Notes on. ....	226-227
Carbonaceous System of Eastern Canada. ....	152	Eastern Ontario. ....	142
Colliery Consumption. ....	30	Economy in Mill Design. ....	245
Colliery Returns. ....	34	Electricity in Cyaniding. ....	32
Colliery Surface Arrangements 155-175-218-247		Gold in Tailings. ....	11-21
Fan, A Combined Exhaust and Blast. ....	108-118	Gravel Benches of the Klondyke. ....	53-89
Gravels of the Yukon. ....	130	Jackson Mines. ....	149
Jigging, Developments in. ....	190	Jigging, Some New Developments in. ....	190
Nova Scotia. ....	201-255	Josie Mines (B.C.). ....	22
Riffle Washers, Some Points on. ....	43	Jumbo Claim (B.C.). ....	180
Roasting Furnaces. ....	4	King, James, The late. ....	125
Royalty (Yukon). ....	1-91	Klondike, Old Valley Gravels of. ....	52
Sampling in Mill Work. ....	63-107	Knob Hill Mine (B.C.). ....	234
Silver Plating Amalgam Plates. ....	9	Kootenay Mining Co., Ltd. ....	169-183
Slimes Treatment. ....	32	Lake of the Woods District. ....	23-41-57-98-119-146-278
Spoon and Grab Dredges. ....	227	Lardeau District (B.C.). ....	23-58-97-119-184-227-278
Wilfley Table Practice. ....	189	Lead Mining in British Columbia. ....	127
Gold Panner Claim. ....	41-58	Leckie, Lieut. J. Edwards. ....	45
Gould Lake Mica Mine (Ont.). ....	140	Le Roi Mining. ....	22-36-172-256-279
Granite Gold Mines, Ltd. ....	120-191	Le Roi No. II. ....	179-278
Granby Con. Mining and Smelting Co. ....	114-234	Le Roi No. III. ....	179
Grant Mica Mine. ....	140	Le Roi No. IV. ....	179
Graphite Mining in Ontario. ....	142	Libbey, Wilbur L. ....	103
Great Western Mines, Ltd. ....	278	Licensing Mine Foremen. ....	31
Guffey-Jennings Gold Mining Co. ....	237	Licensing Mining Engineers. ....	32
Hall Mines, Ltd. ....	25-56	Liquid Air as an Explosive. ....	214
Hendy Two Stamp Mill. ....	280	Liquid Oxygen as an Explosive. ....	57
Heinze v. Angus and Shaughnessey. ....	58	London and B. C. Gold Fields, Ltd. ....	119
Helen Hematite Mine. ....	6	Machine Drills, Stopping with. ....	37-105
Homestake Mine (B.C.). ....	278	Mattawin Iron Co. ....	6
H. W. McNeill Co., Ltd. ....	35	Metasomatic Process in Fissure Veins. ....	245
Imperial Gold Mine (Ont.). ....	23	<b>MICA:</b>	
Intercolonial Coal Co. ....	34-121-199	Eastern Ontario. ....	140
Investors, Hints to. ....	105	Lievre District. ....	235
<b>IRON AND STEEL:</b>		Ottawa County. ....	4
Bell Island Deposits. ....	782-64	Quebec. ....	4-144-235
Blast Furnaces in United States. ....	237	United States. ....	4
Bounties. ....	35		
Canadian Pig Iron Output. ....	212		
Cape Breton. ....	194-197-206-245		
Cast Iron, Testing. ....	201		
Exports from Canada. ....	122		
Fort William Furnace, Proposed. ....	6		
Helen Hematite Mine. ....	6		
Midland Furnace. ....	161		
Mining in British Columbia. ....	127		
Mining in Eastern Ontario. ....	140-258		
Nova Scotia. ....	168-240		
Ontario Mining Fund Payments. ....	44		
Ontario Output. ....	44		
Ores of Hudson's Bay. ....	88		
Plant at Sault Ste. Marie. ....	6-85		
I. X. L. Claim (B.C.). ....	22-180-279		

# INDEX—Continued.

	PAGE.		PAGE.		PAGE.
Midland No. 1 Furnace.....	272	Diamonds.....	87	Safety Appliances in Mines.....	229-250-270
Mikado Gold Mining Co. 7 44-57-99.112-120-215-278		Eastern District of.....	140	Sampling in Mill Work.....	63-107
Mine Accounts.....	12	Frontenac District.....	184	Sampling Mine.....	125
Mine Examinations.....	104	Gold Output of.....	44	Scientific and Industrial Development.....	147
Mineral Exhibit at Paris.....	217	Iron Furnace at Midland.....	161	Semet-Solvey Coke Ovens.....	153
Mine Sampling.....	125	Iron Mining Fund.....	44	Seymour Iron Mine (Ont.).....	140
Mining as an Investment.....	268	Iron Mining in.....	85-258-273	Shaft Sinking under Difficulties.....	122
Mining Errors, A Possible Remedy for.....	173	Iron Output of.....	44	Shareholders, Advice to.....	281
Mining Investments, Reckless.....	2	Lake of the Woods District.....		Silver Bounty.....	35
Mining Machinery, Canadian Trade in.....	105	Mineral Statistics.....	23-37-41-57-98 119-146-278	Silver Mining in British Columbia.....	27
Mining Society of Nova Scotia.....	19-116	Mining in.....	57	Silver Plating Amalgam Plates.....	9
Minnesota Silver Co.....	280	Mining Law.....	49-61-87-101-102-109	Slimes, The Treatment of.....	33
Miocene Gravel Mining Co.....	161	Natural Gas in.....	70-88	Slocan District (B.C.).....	8-185
Molly Gibson Mining Co.....	60-234	Nickel Agitation.....	3-65-92-109-188	Sluicing, Centrifugal.....	214
Mond Nickel Co.....	256	Nickel Output.....	4	Smelting in British Columbia.....	58
Montreal-Boston Copper Co.....	256	Nickel Refining in.....	7	Spitzee Claim (B.C.).....	278
Montreal-London Gold and Silver Dev. Co. 163-256		Notes.....	6-44-106	Standard Copper Company.....	234
McDonald's Bonanza.....	191	Parry Sound District.....	266	Standard Pyritic Smelting Co.....	235
McMillan, N.....	103	Talc Mining.....	7-106-142	St. Charles Iron Mine (Ont.).....	140
Natural Gas in Ontario.....	70-89	Zinc Output of.....	44	St. Eugene Con. Mining Co.....	184-280
Nelson District (B.C.).....	8	Ontario Mining Co.....	3	Stopping with Machine Drills.....	37-105
Newfoundland Colonization and Mining Co.....	60	Ophir Litigation.....	3-267	Sultana Mine (Ont.).....	11-146-278
Newfoundland Iron Mining.....	73-264	Ottawa Gold Mining and Milling Co.....	257	Talc Mining in Ontario.....	7-106-142
<b>NICKEL:</b>		Pacific Coal Co.....	280	Technical Schools.....	112
Clergue's Refining Process for.....	6	Paris Mineral Exhibit from Canada.....	210	Timbering.....	241
Deposits of New Caledonia.....	210-246	Parry Sound District (Ont.).....	266	Treasure Gold Claim (Ont.).....	41-99
Export Duty Agitation.....	33-65-92-109-188	Payne Con. M. and Dev. Co.....	112-256-280	Triggs Mine (Ont.).....	23-41-58-146
Frasch Process.....	188-245	Phosphate Market.....	19	Trojan Gold Claim (Ont.).....	41
Ontario Production.....	4-7-191	Platinum Production in B.C.....	27	Typhoid in Mining Camps.....	112
Refining in Ontario.....	7	Press (Canadian) and Mining.....	106	Van Anda Gold and Copper Co.....	121
Resources of the World.....	210	Prospector, The.....	269	Vancouver and B.C. Gen. Exp. Co.....	24
Nickel Plate Mine (B.C.).....	23	Provincial Mining Bureaus and Geol. Survey.....	165	Vein Geology, Recent Advances in Science of.....	189
Nino Gold Claim (Ont.).....	57	Pumps, Mine.....	51	Velvet Mines, Ltd.....	120-151-180-192-278
Northern Exploration Co. of B.C.....	120	Pyrites Mining in Quebec.....	288	Vermilion Mining Co.....	107
North Star Mining Co.....	143	<b>QUEBEC:</b>		Virginia Gold Claim (Ont.).....	23
Number One Mine (B.C.).....	23	Asbestos.....	5-121-183-194	Wabana Iron Mine (Newfoundland).....	78
<b>NOVA SCOTIA:</b>		Chromite.....	5	Wallbridge Iron Mine (Ont.).....	140
Cape Breton, Prosperity of.....	188	Mica.....	4-144-235	War Eagle Con. M. and Dev. Co.....	27-148-179-278
Coal Mining in.....	34-35-119-197	Mining in.....	57	Waverly Gold Mine (N.S.).....	203
Coal Trade of.....	34-35	Oil Fields.....	116	Wellington Iron Mine (Ont.).....	140
Gold Mining in.....	141-201-255	Pyrites.....	208	Wendigo Gold Claim (Ont.).....	57-146
Iron Ores of.....	168-240	Quebec Central Ry. Mineral Shipments.....	5	West Kootenay District (B.C.).....	51-87
Iron and Steel Works at Sydney.....	207	Rand, Addison, The late.....	44	Wilbur Iron Mines (Ont.).....	140
Metalliferous Mines Act.....	19	Reco Silver Mine (B.C.).....	280	Wilfley Table Practice.....	189
Mining Notes.....	236-255	Richardson Gold Mine (Ont.).....	107	Winding from Great Depths.....	182
Non-Caking Coals of.....	108-117	Richardson Gold Mining Co. (N.S.).....	107-120-237	Wire Rope, Its Uses, Abuses and Care.....	177
Progress of Mining in.....	56	Rifle Washers, Some Points on.....	43	Wire Rope, The Testing of.....	201
Richardson Gold Mine.....	108	Roasting Furnaces for Gold Mines.....	4	Ymir Gold Mines, Ltd.....	59-113-256
Nova Scotia Steel Co.....	199-255	Robertsville Iron Mine (Ont.).....	140	Yukon Gold Fields, Ltd.....	120-191
Old Ironsides Mine (B.C.).....	234	Rock Lake Copper Mining Co.....	256	Yukon Gold Output.....	55-121
Old Valley Gravels of the Klondike.....	53	Romance of Middle Ages, A.....	5	Yukon, Old Valley Gravels of.....	53-89-130
<b>ONTARIO:</b>		Rossland Bonanza Co.....	278	Yukon Royalty.....	1-91
Copper Output of.....	46	Rossland District (B.C.).....	7-22-137-179-237-278	Zenith Zinc Mine.....	46
Corundum Deposits.....	87	Rossland Low Grade Ores, Treatment of.....	131	Zinc Production, Ontario.....	44
		Rossland Proprietary and Mining Co.....	265	Zinc Refining at Hamilton.....	7
		Safer Mining Methods.....	43		

# The CANADIAN MINING REVIEW

Established 1882

Vol. XIX—No. I.

OTTAWA, JANUARY 31st, 1899.

Vol. XIX—No. I.

# RAND

MINING MACHINERY . . . . .  
DUPLEX AIR COMPRESSORS . .  
STRAIGHT LINE COMPRESSORS  
ROCK DRILLS . . . . .

## Canadian Rand Drill Company

MONTREAL.

ALL KINDS OF  
**RUBBER GOODS for MINING PURPOSES**  
MANUFACTURED BY  
\* THE CUTTA PERCHA AND RUBBER MFG. CO. OF TORONTO, \*  
— LIMITED —  
OFFICES 61 & 63 FRONT ST. WEST TORONTO. FACTORIES AT PARKDALE.  
Steam & Air Hose, Rubber Bumpers and Springs, Fire Hose, Pulley Covering, Rubber Clothing & Boots

# INGERSOLL-SERGEANT

For . . . .

Tunnels, Mines  
and Quarries.

# ROCK DRILLS

STRAIGHT LINE, DUPLEX AND COMPOUND

# AIR COMPRESSORS

Stone Channelling Machines, Coal Mining Machines, and Complete  
Plants of Mining Tunnelling and Quarrying Machinery.

\*\*\*\*\*  
**JAMES COOPER MAN'F'G CO. Limited**

299 ST. JAMES STREET, MONTREAL.

BRANCH OFFICES: ROSSLAND, B.C. RAT PORTAGE, ONT HALIFAX, N.S.

# FRIED. KRUPP GRUSONWERK

Magdeburg-Buckau (Germany)

## MINING MACHINERY

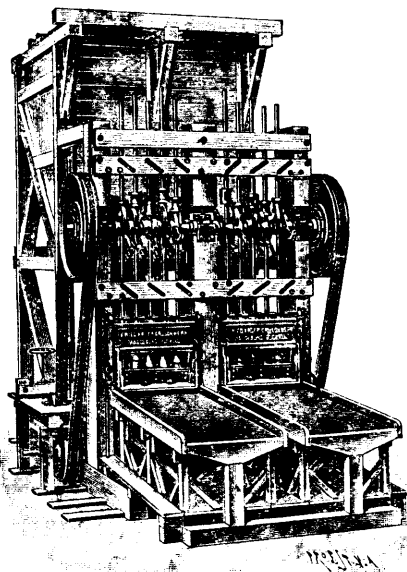

### ORE CRUSHING :

Stone Breakers of specially strong construction, Roller Mills, Chilian Mills.

### BALL MILLS

for dry and wet crushing, more than 1,800 at work.

### STAMP BATTERIES

Shoes and Dies of Krupp's Special Steel.

### AMALGAMATION :

Amalgamation Tables and Pans, Larslo's Gold Amalgamators, Settlers, etc.

### SEPARATION and CONCENTRATION :

Separators, Exhaustors, Hydraulic Classifiers, Percussion Tables, Jiggers, Rotating Round Tables.

### LEACHING PLANT.

## Complete Gold Ore Dressing Plant

- a. For treating by the Wet Method with Stamp Batteries, Amalgamation and Concentration.
- b. For Dry Crushing by Ball Mills Dust Extraction, and Leaching.

## COAL WASHING PLANT

Large Testing Station for Crushing and Dressing Ores at the Works.

Agents :

For Canada : JAS. W. PYKE & Co., 35 St. Francois Xaxier Street, MONTREAL.

For the United States : THOS. PROSSER & SON, 15 Gold Street, NEW YORK.

For Mexico : PABLO BERGNER, Apartado 549, MEXICO.

For South Africa : UNITED ENGINEERING CO., Ltd., P.O. Box 1082, JOHANNESBURG, S.A.R.

# WIRE ROPE

GEO. CRADOCK & CO.

WAKEFIELD, ENGLAND.

Original Manufacturers and Introducers of Lang's Patent.

WINN & HOLLAND - - Montreal

Sole Agents for Canada.

# THE WM. HAMILTON MANUFACTURING CO. Limited

ENGINEERS AND BUILDERS

## MODERN MINING AND MILLING MACHINERY . . . .

## GYRATING VANNER

SHAKES LIKE A PAN.

SEND FOR SPECIAL CIRCULAR.

CONTRACTORS FOR THE DESIGN  
AND CONSTRUCTION OF COMPLETE  
STAMP MILLS, CONCENTRATION,  
CHLORINATION, CYANIDE and  
SMELTER EQUIPMENTS.

Department D.

Peterborough, Ont.

OR

Vancouver, B.C.

# Nova Scotia Steel Co. Ltd.

MANUFACTURERS OF

Hammered and Rolled Steel for Mining Purposes.

Pit Rails, Tee Rails, Edge Rails, Fish Plates, Bevelled Steel Screen Bars, Forged Steel Stamper Shoes and Dies, Blued Machinery Steel  $\frac{3}{8}$ ' to  $3\frac{1}{4}$ " Diameter, Steel Tub Axles Cut to Length, Crow Bar Steel, Wedge Steel, Hammer Steel, Pick Steel, Draw Bar Steel, Forgings of all kinds, Bright Compressed Shafting  $\frac{3}{8}$ ' to 5" true to  $\frac{1}{16}$  part of One Inch.

A FULL STOCK OF MILD FLAT, RIVET-ROUND and ANGLE STEELS ALWAYS ON HAND. SPECIAL ATTENTION PAID TO MINERS' REQUIREMENTS. CORRESPONDENCE SOLICITED.

Works and Office: NEW GLASGOW, N. S.

THOS. FIRTH & SONS, Ltd., Sheffield,  
Tool Steel and Rock Drill Steel  
ALWAYS CARRIED IN STOCK.



SHOES AND DIES.

THOMAS FIRTH & SONS DRILL STEEL  
SHEFFIELD, ENGLAND.

CAMS, TAPPETS, BOSSES, ROLL  
SHELLS, CRUSHER PLATES.

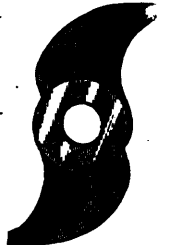

H. W. DeCOURTENAY & CO.

476 ST. PAUL STREET

Agents for Canada.

MONTREAL.



Adamantine Shoes and Dies and Chrome Cast Steel.

THE CANADA PATENT SELF-LOCKING CAM.

TAPPETS, BOSSES, ROLL SHELL and CRUSHER PLATES.

Also Rolled Parts for Huntington and other Mills.

These castings are extensively used in all the Mining States and Territories throughout the World. Guaranteed to prove better and cheaper than any others. Orders solicited subject to above conditions. When ordering send sketch with exact dimensions. Send for Illustrated Catalogue to

CHROME STEEL WORKS,  
BROOKLYN, N.Y., U.S.A.

KENT AVENUE, KEAP  
AND HOOPER STREETS.

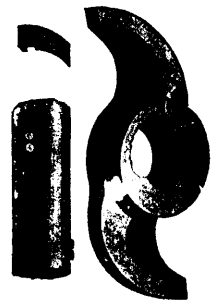

Canada Cam.

C. P. HAUGHIAN, President. F. E. CANDA, Vice-President. C. J. CANDA, Vice-President. F. MORA CANDA, Secretary. T. I. JONES, Treasurer.

## SHOES and DIES

of Superior quality and at prices 20 to 30% lower than any other maker.

FURNISHED BY

ARTHUR KOPPEL,  
66 Broad St., N.Y. City.

WRITE FOR PARTICULARS.

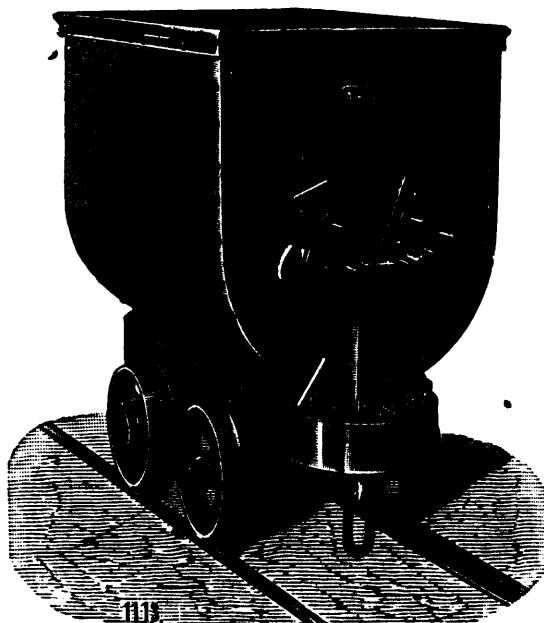

## MINING CARS of every description

PORTABLE RAILWAYS,

Rolling Stock, Railway Outfits for Mines of every description.

Export Work a specialty.

ARTHUR KOPPEL,  
66 Broad St., N.Y. City.

SEND FOR CATALOGUE AND ESTIMATES.

---

# BULLOCK DIAMOND DRILLS

If you are interested in Prospecting send for our

Diamond Drill Catalogue, No. 33.

# BULLOCK MINE VENTILATORS

For further information send for our Catalogue, No. 35.

# BULLOCK HOISTING MACHINERY

Hoisting and Haulage Plants, Portable Hoists

WE CAN FILL ANY REQUIREMENT

# BULLOCK MINING MACHINERY

Ore Cars, Skips, Cages, Cable, &c., &c.

---

...WRITE FOR WHAT YOU WANT...

---

# M. C. BULLOCK MFG. CO.

1177 W. LAKE ST.

CHICAGO, U. S. A.



# Bennett's PATENT Blasting Fuse



FOR  
FIRING EXPLOSIVE CHARGES  
USED IN  
MINES, QUARRIES, COLLIERIES &c  
ADOPTED BY  
THE LEADING CONTRACTORS  
IN EXCAVATING WORKS FOR  
RAILWAYS, DOCKS, CANALS, &c.  
IN ALL PARTS OF THE  
WORLD.



Sole Manufacturers,  
**WM. BENNETT, SONS & CO.**  
ROSKEAR FUSE WORKS,  
CAMBORNE, CORNWALL.

**AGENTS IN CANADA:**

**Ontario Powder Works** - - - **Kingston, Ont.**

**REPRESENTATIVE IN BRITISH COLUMBIA:**

**Mr. Rowland Machin, Hume Hotel,** - - **Nelson, B.C.**

# DIAMOND DRILLS FOR PROSPECTING MINERAL LANDS

Most Accurate and Most Economical Prospecting Drill Made.

The Government of the Province of Ontario purchased in August, 1894, a Sullivan Diamond Drill, Capacity 1500 ft.

The Government of the Province of New Brunswick in February, 1897, purchased a duplicate of the Ontario Drill.

Drills of all capacities, operated by hand or horse power, steam, compressed air or electricity, for sale by

**SULLIVAN MACHINERY COMPANY,**

54 North Clinton Street,

CHICAGO, ILL.

CONTRACTORS FOR PROSPECTING MINERAL LANDS WITH THE DIAMOND DRILL.

# STEEL

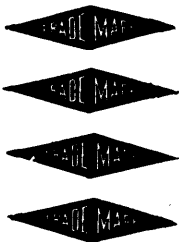

## "Black Diamond" Steel

FOR MINING DRILLS AND  
ALL OTHER PURPOSES

IF YOUR DEALER DOES NOT CARRY IT, WRITE

**PARK STEEL COMPANY**

377 ST. PAUL ST., MONTREAL, QUE.

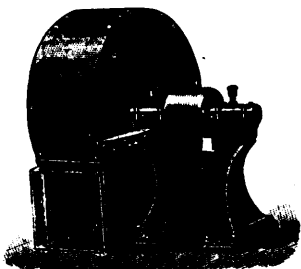

Steel Plate Exhauster for  
Removal of Refuse, Foul Air, etc.

VENTILATING  
EXHAUST and  
PRESSURE . . .

# BLOWERS

WRITE FOR PRICES AND PARTICULARS.

**McEACHREN HEATING AND VENTILATING CO.**

Galt, Ont., Canada.

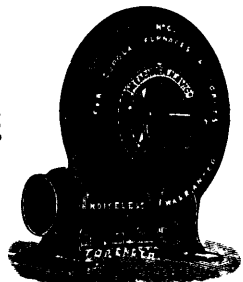

Steel Pressure Blower for  
blowing Cupola and Forge Fires

Established—  
Sheffield, 1776.  
Syracuse, N.Y., 1876.

# Sanderson's Steel

For Drills,  
Tools, Dies, &c.

**A. C. LESLIE CO., Canadian Agents,**

515 Board of Trade, Montreal.

FULL ASSORTMENT OF SELF-HARDENING

AND OTHER GRADES KEPT IN STOCK. . .

## Electric Blasting Apparatus.

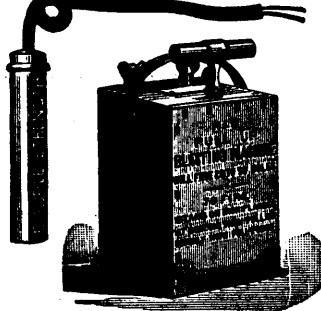

MANUFACTURED  
ONLY BY

Adapted for Firing all kinds of Explosives used in Blasting.

Victor Electric Platinum Fuses.

Superior to all others for exploding any make of dynamite or blasting powder. Each Fuse folded separately and packed in neat paper boxes of 50 each. All tested and warranted. Single and double strength with any length of wires.

Blasting Machines.

The strongest and most powerful machines ever made for Electric Blasting. They are especially adapted for submarine blasting, large railroad quarrying, and mining works.

Victor Blasting Machine.

Fires 5 to 8 holes; weighs 15 lbs., adapted for prospecting, etc.

Insulated Wires and Tapes,

Blasting Caps, Fuse, Etc.



SEND FOR  
CATALOGUE

**JAMES MACBETH & CO., 128 Maiden Lane, New York, U.S.A.**

# MILL AND MINING MACHINERY

Shafting, Pulleys, Gearing, Hangers, Boilers, Engines, Steam Pumps, Chilled Car Wheels and Car Castings. Brass and Iron Castings of Every Description. Light and Heavy Forgings.

**ALEX. FLECK, - Vulcan Iron Works, - OTTAWA.**

# RICE LEWIS & SON, Limited

ARTHUR B. LEE, President.

TORONTO

A. BURDETT LEE, Vice-Pres. and Treas.

Picks, Shovels

Dynamite

Fuse

Wire Rope and Cables

Powder

Bar Iron

Chain

Detonators

Steel

DRILL STEEL in long and short lengths.

HARDWARE, STEAM AND COMPRESSED AIR HOSE,  
VALVES, PIPE, FITTINGS, ETC.

# THE BUCYRUS COMPANY

DESIGNERS AND BUILDERS OF

Dredges, Steam Shovels, Excavating Machinery, Steam, Electric and Locomotive Cranes. Centrifugal Pumps, with Simple, Compound or Triple Expansion Engines. Pile Drivers, Wrecking Cars, Placer Mining Machines, South Milwaukee, Wisconsin.

Iron and Steel Structures for Collieries,  
Metal Mines and Smelting Works. . . .

Steel Bridges for Railways and Highways. Steel Piers and Trestles. Steel Water Towers and Tanks. Steel Roofs, Girders, Beams, Columns, for Buildings.

A LARGE STOCK OF

ROLLED STEEL BEAMS, JOISTS, GIRDERS, CHANNELS, ANGLES, TEES, Z BARS AND PLATES

ALWAYS ON HAND, IN LENGTHS TO THIRTY-FIVE FEET

Tables, giving Sizes and Strength of Rolled Beams, on application.

Post Office Address,

MONTREAL.

**Dominion Bridge Co., Ltd.,**

Montreal and  
Lachine Locks, P. Q.

# JEFFREY

Coal Mining Machinery and  
Coal Handling Machinery



CHAIN COAL CUTTERS.

UP-TO-DATE  
MINE EQUIPMENTS.

MINES EXAMINED.  
ESTIMATES FURNISHED.

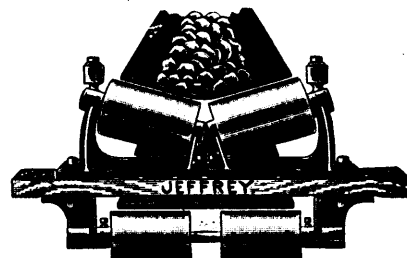

**CENTURY BELT CONVEYORS**  
FOR HANDLING  
COAL, ASHES, SAND, GRAVEL, ORES,  
STONES, Etc. Etc.

New York  
41 Dey St.

**The Jeffrey Mfg. Co.**

**COLUMBUS, OHIO,**  
U. S. A.

# GATES IRON WORKS

The Gates Gyratory Rock and Ore Breaker, a cut of which is presented, is the most perfect machine of its kind that mechanical science has been able to produce. Its crushing product is cubiform, its capacity is greater than that of any similar machine, and it is operated at less cost.



We have manufactured Mining Machinery longer than any other house in business. Our machines are used in every mining district in the world. Our sales during the current year have been unparalleled, the increase in business being greater than in any other year of our existence.

WE MANUFACTURE ROCK CRUSHING, ORE CRUSHING, MINING AND CEMENT MACHINERY.

GATES IRON WORKS, Department 5, 650 ELSTON AVENUE, CHICAGO, ILL.

For  
Miners  
Pit Sinkers

## DYNAMITE AND EXPLOSIVES

For  
Quarrymen  
Contractors

... Manufacturers and Dealers in ...

### ELECTRIC BLASTING APPARATUS, FUSE, CAPS, &c.

DAN'L SMITH  
C. A. MACPHERSON  
Proprietors.

### ONTARIO POWDER WORKS

176 ONTARIO STREET

Kingston, Ont.

MACHINERY DEPOT.

## A. R. WILLIAMS & CO.

Write for Quotations on Mining and Quarrying Machinery, Engines, Boilers, Pumps, Ore Breakers and Machinery Supplies of all Kinds—Immense Stock.

345-347 St. JAMES STREET, MONTREAL, QUE.

## School of Practical Science, Toronto

ESTABLISHED 1878.

AFFILIATED TO THE UNIVERSITY OF TORONTO.

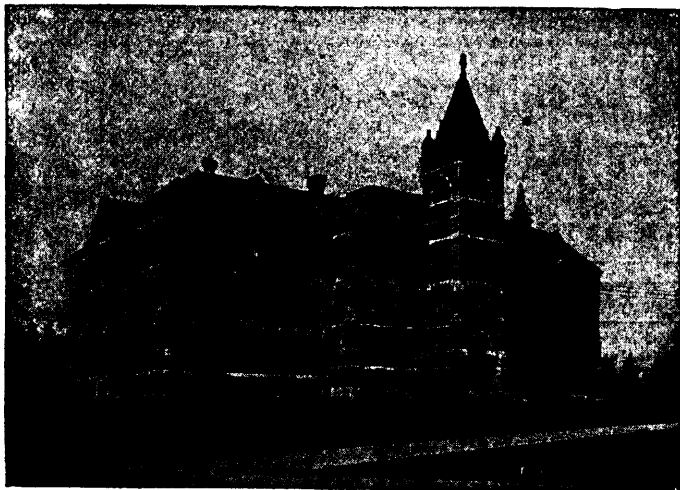

This School is equipped and supported entirely by the Province of Ontario and gives instruction in the following departments:

- 1—CIVIL ENGINEERING
- 2—MINING ENGINEERING
- 3—MECHANICAL & ELECTRICAL ENGINEERING
- 4—ARCHITECTURE
- 5—ANALYTICAL AND APPLIED CHEMISTRY

Special Attention is directed to the Facilities possessed by the School for giving Instruction in Mining Engineering. Practical Instruction is given in Drawing and Surveying, and in the following Laboratories:

- |            |                |              |
|------------|----------------|--------------|
| 1—CHEMICAL | 3—MILLING      | 6—ELECTRICAL |
| 2—ASSAYING | 4—STEAM        | 7—TESTING    |
|            | 5—METROLOGICAL |              |

The School also has good collections of Minerals, Rocks and Fossils. Special Students will be received as well as those taking regular courses.

FOR FULL INFORMATION SEE CALENDAR.

L. B. STEWART, Secretary.

# Electric Blasting Apparatus.

ADAPTED FOR FIRING ALL KINDS OF EXPLOSIVES USED IN BLASTING.

## Victor Electric Platinum Fuses.

Superior to all others for exploding any make of dynamite or blasting powder. Each fuse folded separately and packed in neat paper boxes of 50 each. All tested and warranted. Single and double strength with any length of wires.

**INSULATED WIRES AND TAPES.  
BLASTING CAPS, FUSE, ETC.**

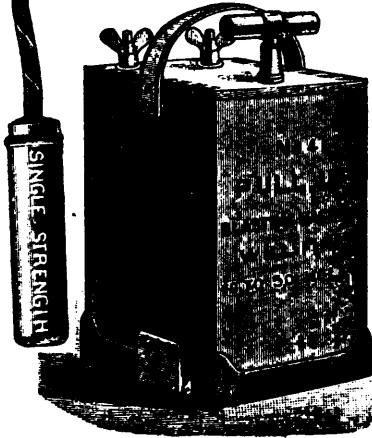

Price, \$30.

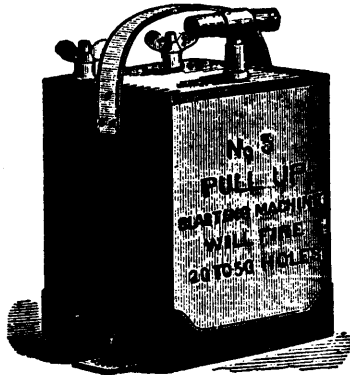

Price, \$25.

## Blasting Machines.

The strongest and most powerful machines ever made for electric blasting. They are especially adapted for submarine blasting, large railroad quarrying, and mining works.

### VICTOR BLASTING MACHINE.

Fires 5 to 8 holes. Weighs 15 lbs. Adapted for Prospecting, etc.



Price, \$25.



CONNECTING WIRE.  
Price, 40c. per lb.

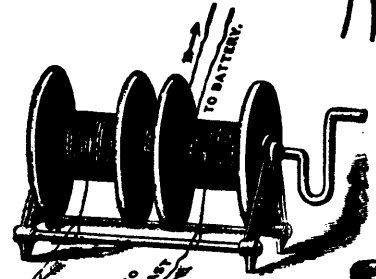
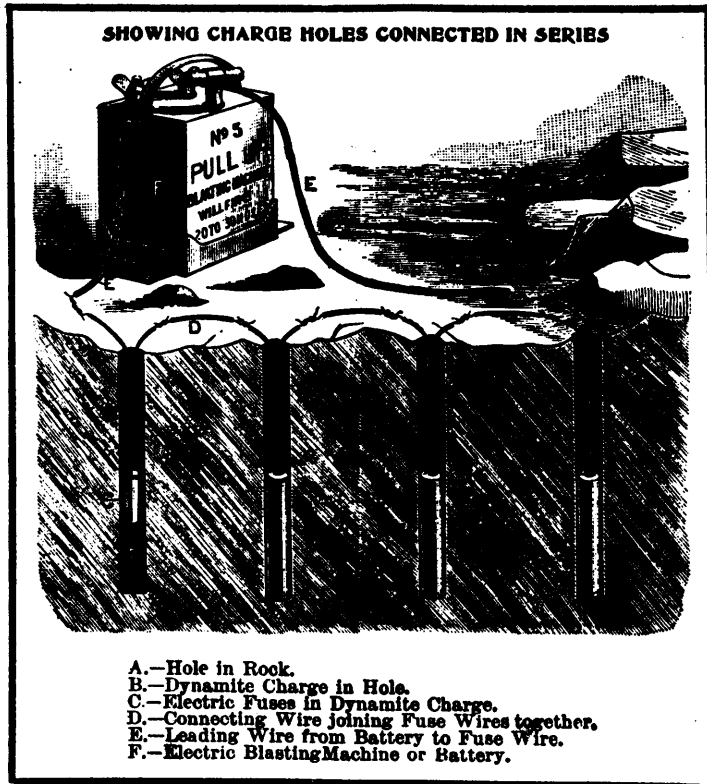

VICTOR LEADING WIRE REEL.  
Price, \$4.

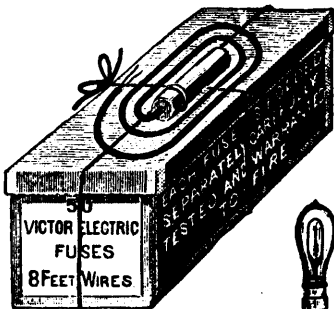

50 Fuses in each box.

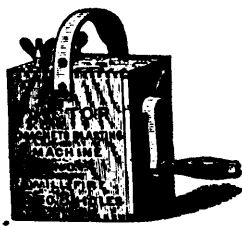

Price, \$15.



BATTERY TESTING LAMP. Price, \$3.50.

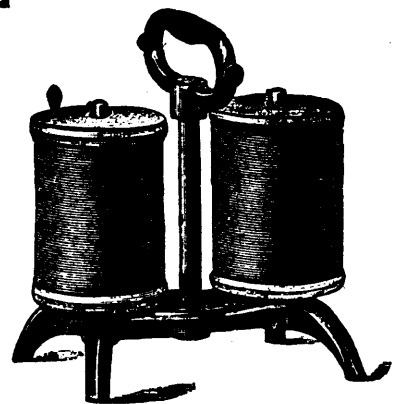

CONNECTING WIRE HOLDER.  
Price, \$2.

MANUFACTURED ONLY BY

## JAMES MACBETH & CO., 128 Maiden Lane, New York, U. S. A.

For Sale by Dynamite Manufacturers, Agents and Dealers, everywhere. Special Discount on Export Orders.  
Catalogue mailed free on application.

# CANADIAN GENERAL ELECTRIC COMPANY, Ltd.

Head Office: 65 FRONT ST. WEST, TORONTO, ONT.

### BRANCH OFFICES AND WAREHOUSES

1802 Notre Dame St.	- - -	MONTREAL	}	Main Street	- - - - -	WINNIPEG
138 Hollis Street	- - -	HALIFAX		Granville Street	- - - - -	VANCOUVER

NELSON, B.C.

FACTORIES: PETERBOROUGH, ONT.

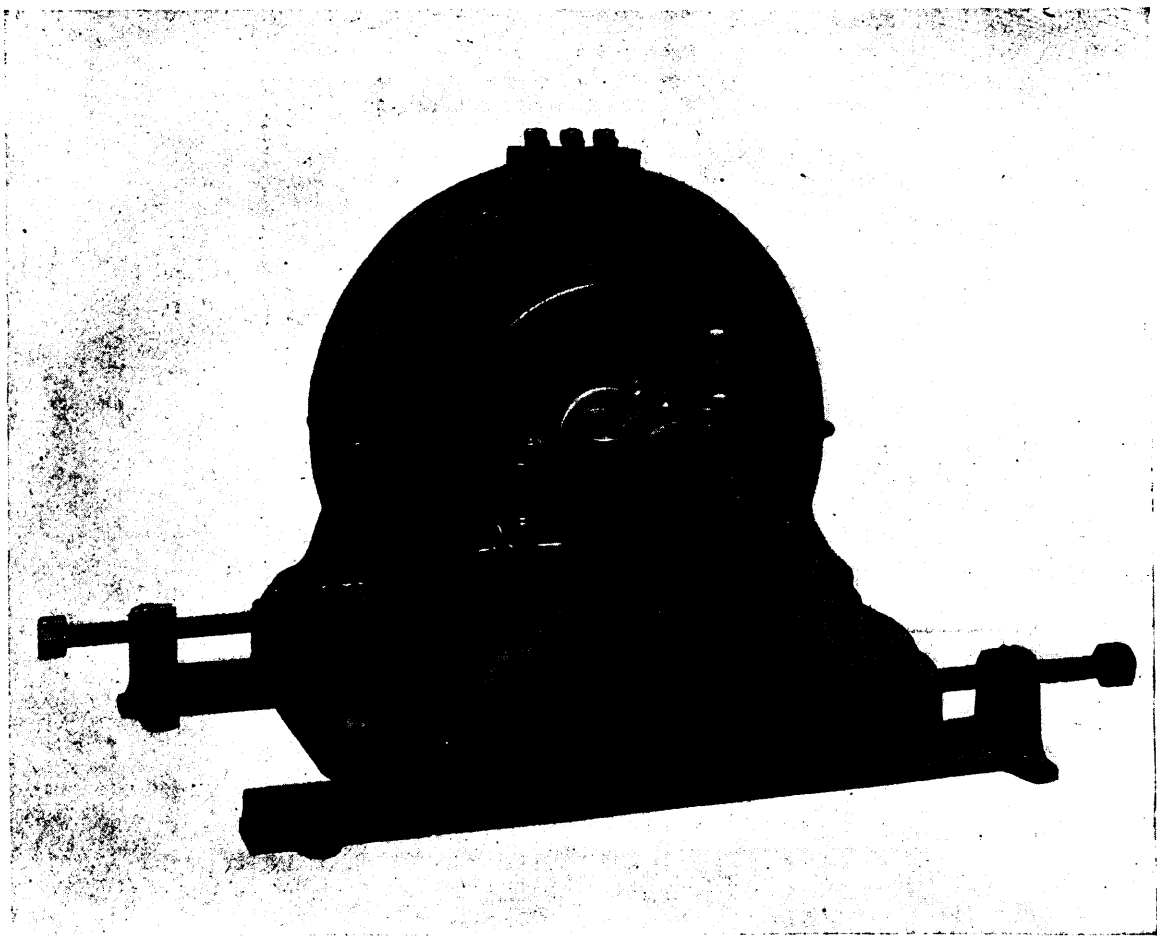

10 H.P. INDUCTION MOTOR.

## INDUCTION MOTORS

SPECIALLY ADAPTED FOR DRIVING

PUMPS,  
 COMPRESSORS,  
 HOISTS,

VENTILATORS,  
 STAMPS,  
 COAL CUTTERS, Etc.

Send for Illustrated Catalogues of Electric Mining Apparatus.

# MINE EQUIPMENT



COMPLETE PLANTS FOR THE EXCAVATION AND TREATMENT OF

## ROCK, COAL and ORE

WE MAKE A SPECIALTY OF

Rotary and Side Dumping Ore Cars with McGaskill Wheels and Boxes

Gages and all Hoisting Appliances . . . . .

Self Dumping Ore Buckets and Skips, Water Buckets . . . . .

## HOISTING, WINDING and HAULAGE ENGINES

OF LOCOMOTIVE LINK MOTION AND FRICTION TYPES.

<b>INGERSOLL-SERGEANT . . .</b>
<b>PISTON INLET AIR COMPRESSORS</b>
<b>ROCK DRILLS, COAL CUTTERS</b>

STAMP MILL MACHINERY.

ORE AND ROCK CRUSHING PLANTS.

Complete Estimates furnished on application to Main Office or Branch Offices.

# JAMES COOPER MAN'F'G CO. Limited

MONTREAL.

BRANCH OFFICES: 116 Hollis St., Halifax, N.S. Hilliard Opera House Block, Rat Portage, Ont. P.O. Building, Rossland, B.C.

## OLD SYDNEY COAL.

.....

S. CUNARD & CO., Halifax, N. S.

Shipping, Commission and Coal Merchants, Agents for  
Allan, Cunard, White Star, American, Red Star, Hill,  
Atlantic Transport, Compagnie Generale Trans-  
Atlantique Lines of Steamers; also

**General Mining Association, Ltd.**

**COLLIERY, SYDNEY MINES, C. B.**

Liverpool, Glasgow, French and Austrian Underwriters.

CONSULAR AGENCY OF FRANCE.

BUNKERING STEAMERS ATTENDED TO WITH DESPATCH

## SPRINGHILL COAL.

**THE CUMBERLAND RAILWAY & COAL COMPANY**

Are prepared to deliver this well known Steam  
Coal at all points on the lines of G.T.R.,  
C. P. R. and I. C. Railways.

**HEAD OFFICE: 107 ST. JAMES STREET, MONTREAL.**

Address: P. O. BOX 396.

## Drummond Coal.

**THE INTERCOLONIAL COAL MINING CO. LIMITED.**

CHARLES FERGIE, Vice-Pres. and Manager.  
WM. J. NELSON, Secretary-Treasurer.

**Drummond Colliery, Westville, Nova Scotia.**

CHAS. FERGIE, M.E., Manager.

MINERS AND SHIPPERS OF

**BITUMINOUS COAL AND COKE**

At Picton Harbour and Intercolonial Ry.

HEAD OFFICE: MONTREAL.

# DOMINION COAL COMPANY

OWNERS OF THE

Victoria, International,  
Dominion, Bridgeport,  
Gowrie, Caledonia,  
and Reserve Collieries,

OFFERS FOR SALE

**STEAM, GAS and DOMESTIC**

OF HIGHEST **COALS** QUALITIES

Carefully prepared for Market by Improved Appliances, either  
F.O.B. or Delivered.

*It is also prepared to enter into Contracts with  
Consumers covering a term of years.*

*Its facilities for supplying Bunker Coal with  
promptness is unequalled.*

APPLICATION FOR PRICES, ETC., TO BE MADE TO

**J. S. McLENNAN, Treasurer,**  
95 MILK ST., BOSTON, MASS

HIRAM DONKIN, Resident Manager, Glace Bay, Cape Breton.  
M. R. MORROW, - - - - - 50 Bedford Row, Halifax.  
KINGMAN & CO., - - - Custom House Square, Montreal.

HARVEY & OUTERBRIDGE, Produce Exchange Building, New  
York, Sole Agents for New York and for Export



# CALEDONIAN IRON WORKS

JOHN McDOUGALL, - MONTREAL, OUE.

## BOILERS

TANKS AND  
WROUGHT IRON  
WORKS . . . . .

HYDRAULIC AND MILL MACHINERY

GEARS, PULLEYS, HANGERS

IRON CASTINGS OF EVERY DESCRIPTION

GENERAL AGENTS  
IN CANADA FOR

## WORTHINGTON PUMPS

Meters, Etc., Rife Hydraulic Engines and The New York  
Filter Manufacturing Company.

## ENGINES      BOILERS      MINING MACHINERY

CORLISS HIGH SPEED AND MARINE ENGINES  
STATIONARY, LOCOMOTIVE AND MARINE BOILERS

ALL KINDS TANK WORK.      ICE AND REFRIGERATING MACHINERY.

Shafting, Pulleys, Hangers, Iron and Brass Castings, Etc.

## John Inglis & Sons, Toronto

Send for  
our  
Prices.

## RAILS

NEW AND SECOND HAND

For Railways and Tramways

JOHN J. GARTSHORE, 83 Front Street West

Opposite Queen's Hotel

TORONTO, ONT.

## MINING EQUIPMENT, Etc.

## A. LESCHEN & SONS ROPE CO.

MANUFACTURERS OF ALL KINDS OF



PATENT FLATTENED  
STRAND WIRE ROPE.

## Round Strand Rope

Also

Aerial  
Wire  
Rope

## TRAMWAYS

FOR TRANSPORTATION OF ORE, TIMBER, &c.

Main Office : 920-922 North Main Street, ST. LOUIS, MO.

Branch Office : 47-49 South Canal Street, CHICAGO, ILL.

# KING BROTHERS

15 BELLS LANE, QUEBEC.

## Lumber, Asbestos, Chromic Iron.

Mills at River Ouelle, Lyster, Kingsburg, Pabos, Cedar Hall.  
Asbestos,—Crude, Fibreized and Paper Stock Hampden  
Mine, Thetford.  
Chromic Iron Mine,—Black Lake.

## REDDAWAY'S PATENT

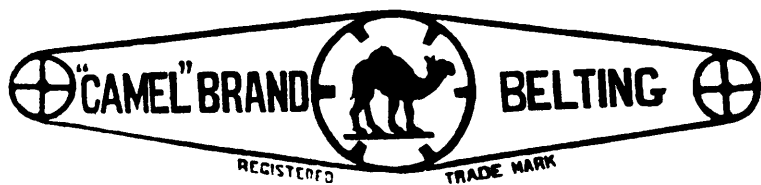

Specially Adapted for Heavy Drives in Damp or  
Exposed Places, in Mines, Saw Mills,  
Paper and Pulp Mills, Etc.

CHEAPER, LIGHTER, MORE PLIABLE and  
MORE DURABLE THAN DOUBLE LEATHER

W. A. FLEMING & CO., SOLE AGENTS  
FOR CANADA.

27 St. Francois Xavier Street, Montreal  
Victoria Chambers, Ottawa.

# WATER WHEELS

SAMSON and  
CASCADE

ADAPTED TO ALL HEADS FROM

3 Feet to 2000 Feet.

Specially designed and adapted to  
MINING, IRRIGATING AND ELECTRIC

Power purposes. Securing a high guaranteed percentage  
and great steadiness of motion, under variable loads. An  
unequaled concentration of power and an unprecedented  
high velocity. Their quickly operating balanced gates,  
affords prompt and fine regulation by governor. Satisfac-  
tion guaranteed where others fail. Write for pamphlet  
of either wheel, stating your Head pressure and your wants.

JAMES LEFFEL & CO., Springfield, Ohio, U. S. A.



## SADLER & HAWORTH

MANUFACTURERS OF

OAK TANNED  
LEATHER BELTING...

MONTREAL and  
TORONTO.

# THE ROYAL ELECTRIC CO.

MONTREAL  
TORONTO

MANUFACTURERS  
OF

## HIGH CLASS

## ELECTRICAL

## APPARATUS

... FOR ...

## LIGHT HEAT POWER

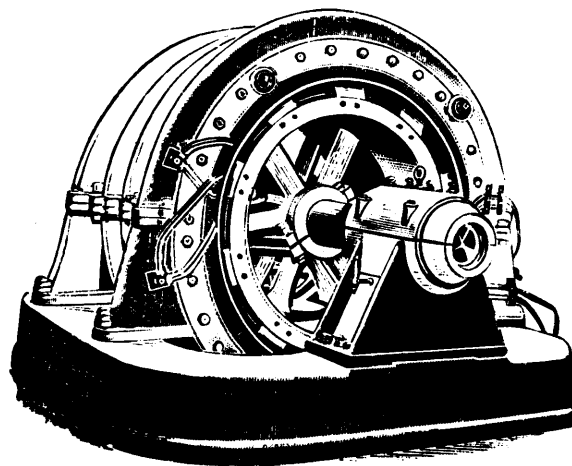

1000 K.W.S.K.C. Two-phase Direct Connected Generator  
Installed for CATARACT POWER CO., Hamilton.

COAST AGENTS:

GEO. C. HINTON & CO.  
VICTORIA. VANCOUVER.

**JOSHUA HENDY MACHINE WORKS**

Nos. 38 to 44 Fremont Street,

SAN FRANCISCO, CAL.

**QUARTZ, HYDRAULIC MINING AND SAWMILL MACHINERY**

MINING, MILLING, HOISTING AND PUMPING PLANTS,  
 BOILERS, ENGINES AND PUMPS OF EVERY DESCRIPTION.  
 AIR COMPRESSORS AND ROCK DRILLS,  
 TRIPLE DISCHARGE TWO STAMP MILLS.  
 SPECIALTIES OF PROSPECTING PLANTS.

HYDRAULIC GRAVEL ELEVATORS, WATER LIFTERS, DOUBLE JOINTED BALL  
 BEARING AND SINGLE JOINTED GIANTS, HYDRAULIC DERRICKS,  
 RESERVOIR GATES, WATER GATES, WATER WHEELS,  
 RIVETED HYDRAULIC PIPE.

ORE CRUSHERS, ORE FEEDERS AND CONCENTRATORS,  
 ORE BUCKETS, MINING CARS AND GENERAL MINING SUPPLIES.  
 "DAVIS" HORSE POWER HOISTING WHIMS.

PLANS, SPECIFICATIONS and ESTIMATES FURNISHED.

Catalogues on Application.

For  
 Miners  
 Pit Sinkers

**DYNAMITE AND EXPLOSIVES**

For  
 Quarrymen  
 Contractors

... Manufacturers and Dealers in ...

**ELECTRIC BLASTING APPARATUS, FUSE, CAPS, &c.**

DAN'L SMITH,  
 C. A. MACPHERSON,  
 Proprietors.

**ONTARIO POWDER WORKS**

176 ONTARIO STREET

Kingston, Ont.

**The DOMINION RADIATOR CO. Limited**

DEALERS

IN THE MOST COMPLETE LINE OF

**Steamfitters' Specialties**

Stafford Steam and Hot Water  
 Radiators

Steam Traps, Separators

Wrought Iron Pipe

Cast and Malleable Fittings

Also Galvanized Pipe and Fittings

Brass and Iron Body Valves, Etc.

Boilers for Steam and Water.

HEAD OFFICE AND WORKS:

340 to 376 Dufferin Street

TORONTO, ONT.

**John E. Hardman, S.B.**

CONSULTING  
MINING ENGINEER,  
Room 2,  
Windsor Hotel. **Montreal, Que.**

20 Years' Experience in the Mining and Reduction of Gold, Silver, Lead and Copper.  
13 Years as a Specialist in Gold Mining and Milling.

**ERNST A. SJÖSTEDT, M.E.**

Metallurgical Engineer and Assayer.

Graduate School of Mines, Stockholm.  
Twenty-one years experience as Chemist and Manager of Iron and Steel Works.

Assaying of ores, metals, fuels and furnace products.  
Consultation re furnace charges and cupola mixtures.  
Designing and constn. of roasting kilns and gas producers, etc.  
Reports on mines and processes.

210 or 214 St. James St., MONTREAL.  
Cable and Telegraph address:—"Sjostedt, Montreal."

MONTREAL TESTING LABORATORY.

**MILTON L. HERSEY, M.A.Sc. (McGill)**

CONSULTING CHEMIST OF THE  
CANADIAN PACIFIC RAILWAY COMPANY.

16 ST. SACRAMENT ST., MONTREAL.

**ASSAYS OF ORES**

ANALYSES of all materials made with greatest accuracy.  
SAMPLES BY MAIL—1 cent per 4 ozs.; limit 24 ozs.  
INSTRUCTION IN ASSAYING, Etc., to Prospectors and others.

MINERAL PROPERTIES EXAMINED.

**J. T. DONALD,**

Assayer and Mining Geologist,

112 St. Francois-Xavier St., MONTREAL.

Analyses and Assays of Ores, Fuels, Furnace Products, Waters, etc. Mines and Mining Properties examined and valued.

**F. H. MASON**

Fellow of the Chemical Society, London.  
Late Chemist and Assayer to the Newbery  
Vautin Patents Gold Extraction Co., Limited.

Consulting Metallurgist and Chemist  
Analytical Chemist and Assayer

Chemical and Metallurgical Processes investigated.  
Metallurgical Plants designed.

Specialty—Refractory Ores, Concentrates & Tailings

LABORATORY, QUEEN BUILDING,  
Halifax, N.S.

**J. W. EVANS**

CIVIL AND MINING ENGINEER  
AND ASSAYER.

SUBURRY, ONTARIO, CANADA

Mining properties and mines examined and reported on.  
Assays and analyses made of ores, minerals and metals.

Specialty—NICKEL.

**A. H. HOLDICH**

REVELSTOKE, B.C.

ANALYTICAL CHEMIST AND ASSAYER.

FROM ROYAL SCHOOL OF MINES,  
LONDON.

Seven years at Morfa Works, Swansea; seventeen years Chief Chemist to Wigan Coal and Iron Company, England, is now prepared to undertake every description of Analyses or Assays.

**WM. HAMILTON MERRITT, F.G.S.**

Associate Royal School of Mines, &c.

Mining Engineer and Metallurgist

Will report on Mines and Mineral Properties.

ADDRESS:

15 TORONTO ST., TORONTO, ONT.

**F. HILLE,**

MINING ENGINEER

Mines and Mineral Lands examined and reported on. Plans and Estimates on Concentrating Mills after the Krupp-Bilharz system.

PORT ARTHUR, ONT. CANADA.

**E. E. BURLINGAME & CO.,  
ASSAY OFFICE AND CHEMICAL  
LABORATORY**

Established in Colorado, 1866. Samples by mail or express will receive prompt and careful attention  
Gold & Silver Bullion Refined, Melted and Assayed  
OR PURCHASED.  
Concentration Tests—100 lbs. or car load lots.  
Write for terms.  
1736-1738 Lawrence St., Denver, Colo.

**J. BURLEY SMITH**

Civil and Mining Engineer.

30 YEARS EXPERIENCE.

RAT PORTAGE - ONTARIO

Undertakes the Prospecting of  
Mines and Mineral Lands . . .

Diamond Drill Borings made by contract for all minerals (earthy and metalliferous), Artesian Wells and Oil Springs, also Deep Soundings for Harbors, Rivers, Canals, Tunnels and bridge Foundations.

Quarry Sites and Clay Fields tested.  
Plans and Sections made showing result of Borings—Gold Drifts tested to Ledge by the new Pneumatic and Hydraulic Tube System and the yield ascertained—Flumes, Ditches, Monitors and Placer Mining Plant generally designed and constructed.

Properties Examined and Reported on and Assays made.

**JOHN McAREE, B. A. Sc.,**

Graduate School of Practical Science,  
Toronto University.

MINING ENGINEER AND ASSAYER.

Ontario and Dominion Land Surveyor.  
Surveys, Reports, Prospecting, Development.  
Three years experience in the Rainy River District

RAT PORTAGE, ONT.

**DIVIDEND PAYING**

*Mining Stocks and  
Other Investments.*

ALL REPRESENTATIONS GUARANTEED.

J. M. HARRIS, SANDON.

**J. H. Chewett, B.A. Sc.**

(Honor Graduate in Applied Science, Toronto University)

Assoc. Mem. Can. Soc. C.E.

Mining Engineer

Consultation. Reports. Development.

87 YORK ST., ROSSIN BLOCK, TORONTO.

J. B. TYRRELL, M.A., F.G.S.

T. D. GREEN, C.E., D.L.S.

**Tyrrell & Green,**

MINING AND CIVIL ENGINEERS

DOMINION LAND SURVEYORS.

Mining Properties Examined valued and reported upon. Surveys made. Money Invested, Etc.

12 Harper Street.  
In rear of Klondike Hotel. **DAWSON, Y.T.**

JOHN B. HOBSON,  
Min. Eng. and Metallurgist.

L. F. WARNER, JR.  
Hydraulic and Min. Eng.

**HOBSON & WARNER**

Mining Engineers.

Twenty Years Practical Experience in California

Will examine and report on mining properties  
in Canada and the United States.

The Equipment and Opening of Deep Gravel  
Drift, Hydraulic and Gold Quartz  
Mines a Specialty.

QUESNELLE FORKS, BRITISH COLUMBIA.

Agents for the Joshua Hendy Machine Works,  
Hydraulic and Mining Machinery, and the Well's  
Lights, for use in Hydraulic Mines.

REPRESENTED AT VANCOUVER BY

**J. M. BROWNING.**

Corner Granville and George Streets,  
Vancouver, British Columbia.

RONALD HARRIS,  
C. & M.E.

J. EDWARDS LECKIE,  
B.Sc. C. & M.E.

**HARRIS & LECKIE**

MINING  
ENGINEERS

Box 79 **GREENWOOD, B.C.**

**HOWARD WEST**

(Associate of Royal School of Mines, London)

Mining Engineer, Analytical Chemist and Assayer

THREE YEARS IN THE KOOTENAY.

Properties Examined and Reported on for intending  
Purchasers.

BELLVUE AVE., NEW DENVER, B.C.

A B C CODE.

**A. W. STEVENSON**

CHARTERED  
ACCOUNTANT

MINING AND INVESTMENT BROKER.

BANK OF TORONTO  
CHAMBERS

...MONTREAL

# HENRY BATH & SON,

London, Liverpool and Swansea,  
**BROKERS.**

All Description of  
Metals, Mattes, Etc.  
Warehouses, Liverpool and Swansea.  
Warrants Issued under their Special Act of  
Parliament.

## NITRATE OF SODA.

Cable Address: - BATHOTA, LONDON.

# R. T. Hopper & Co.

SUCCESSORS TO IRWIN, HOPPER AND CO.  
ESTABLISHED 1878.

## Miners and Shippers of Minerals, &c.

58 Canada Life Building, Montreal, Can.

Asbestos, Crude and Manufactured, Mica,  
Plumbago, Soapstone, Etc.

# MICA BUYERS

## EUGENE MUNSELL & Co.

218 WATER STREET  
NEW YORK.

Canadian Branch:

332 WELLINGTON ST. OTTAWA, ONT.

ZINC  
LEAD  
SILVER  
IRON  
COPPER  
Etc.

# ORES

MATTE  
DROSS  
ASHES  
SKIMMINGS  
DUST  
Etc.

Sellers of above are specially requested to  
communicate with

## L. Le PERSONNE & CO.

99 Cannon St. London, E.C. (ALSO IN ANTWERP.)  
Telegraphic Address: "LEPERSONNE, LONDON."  
Telephone No. 5,144, Bank.

## MINERAL and METAL BROKERS.

Contracts Negotiated. Selling and Buying Agencies  
undertaken. Consignments Received, Weighed,  
Sampled, Assayed, and Advances made.

Orders executed and Buying Agencies undertaken for  
Colonial Firms of good standing for  
Machinery, Tools, Steel for Miners' Drills.

## IRON & STEEL RAILS, JOISTS, BARS, RODS, PLATES, SHEETS, HOOPS, WIRE, NAILS. BOLTS AND NUTS.

Galvanised Sheets and Hoops, Tin Plates, Zinc  
Sheets and Discs, Spelter, White Lead.

## WINDOW AND PLATE GLASS.

Sole Agents for the Sale of STEEL JOISTS, RAILS,  
BILLETS from the Micheville Steel Works Co.  
CAST IRON PIPES and CASTINGS from the  
Aubrives and Villerupt Metallurgic Co.

Sole Agents for FIRE ARMS from Messrs. AUGUSTE  
FRANCOTTE & CO.

Established 1810. Contractors to the British  
and other Governments.

Patentees and Manufacturers of the "Martini-Francotte"  
Detachable Rifle Action, fitted with "Francotte"  
"Indicators," showing when the rifle is ready for  
firing and also when a loaded cartridge is in the  
chamber. This action can be easily removed without  
the aid of a tool, giving greater facility to clean the  
barrel, etc. than in the ordinary Martini-Henry rifles

## LICENSES TO PROSPECT

or work Minerals on any of their Lands and Reserva-  
tions covering nearly a quarter of a million acres in  
Eastern Ontario, and principally within the belts con-  
taining Iron, Phosphate, Gold, Galena, Plumbago,  
Mica, Marble, Building Stone, and other valuable  
minerals, are issued by

## The Canada Company

For list of lands and terms apply to the Company's  
Mining Inspector and Agent

ANDREW BELL, C.E., D.L.S., Etc.,  
ALMONTE, ONT.

## OLDEST EXPERTS IN

Molybdenite,  
Scheelite,  
Wolframite,  
Chrome Ore,  
Nickel Ore,  
Cobalt Ore,  
Cerium, and  
all Ores  
and Minerals

Talc,  
Mica,  
Barytes,  
Graphite,  
Blende,  
Corundum,  
Fluorspar,  
Feldspar.

LARGEST BUYERS. BEST FIGURES.  
ADVANCES ON SHIPMENTS.  
CORRESPONDENCE SOLICITED.

CARLES—Blackwell, Liverpool, ABC Code, Moreing  
& Neal, Mining and General Code, Liebers  
Code and Mullers Code.  
ESTABLISHED 1869.

# NICKEL...

BEST QUALITY FOR ANODES

GERMAN SILVER AND NICKEL STEEL.

## The CANADIAN COPPER CO.

12 Wade Building

CLEVELAND, OHIO, U.S.A.

Cable Address: "CUNICKLE."

Use Lieber's or London 4th Edition  
A B C Code.

# BAKER & CO. PLATINUM REFINERS.

Material of all kinds containing Gold,  
Silver or Platinum either refined  
or purchased.

Manufacturers of Platinum Apparatus  
of all kinds for Laboratory and  
Chemical purposes.

NEWARK, N.J.

New York Office: 121 LIBERTY STREET.

Send for Pamphlet—PLATINUM—containing  
notes of interest to miners and prospectors

## LABORATORY OF

The Ottawa Gold Milling and Mining Co.  
KEEWATIN, ONT.

## Sampling, Assaying and Analysis

OF ORES, MATTES and  
MINERAL PRODUCTS

In lots from hand samples to one thousand tons.  
Any size—laboratory working tests or mill runs  
—any process.

High Accuracy Determinations a Specialty

# LEDOUX & Co.

99 JOHN ST., NEW YORK.

## Sample and Assay Ores and Metals.

Independent Ore  
Sampling Works  
at the Port of  
New York. Only  
two such on the  
Atlantic seaboard

We are not Dealers or Refiners, but Receive  
Consignments, Weigh, Sample and Assay them,  
selling to highest bidders, obtaining advances when  
desired, and the buyers of two continents pay the  
highest market price, in New York Funds, cash  
against our certificates.

MINES EXAMINED AND SAMPLED.  
ALSO ANALYZE EVERYTHING.

## ORFORD COPPER CO.

ROBERT M. THOMPSON, President.  
99 JOHN ST., NEW YORK.

## Copper and Nickel Smelters

WORKS AT CONSTABLE'S HOOK, N. J.  
Opp. New Brighton, Staten Island.

Copper Ore, Mattes, or Bullion Purchased. Advances  
made on Consignments for Refining and Sale.

Specialty made of Silver-bearing Ores and Mattes—  
Copper Ingots, Wire Bars and Cakes—Ferro-Nickel  
and Ferro-Nickel Oxides for use in preparing Nickel  
Steel for Armour Plates.

NICKEL AND NICKEL OXIDES.

# BALBACH Smelting and Refining COMPANY

EDWARD BALBACH, Jr. - - - President  
J. LANGELOTH, - - - Vice-President

NEWARK, NEW JERSEY.

Smelters and Refiners of Gold, Silver,  
Lead and Copper Ores.

Bullion and Argentiferous Copper Matte  
received on Consignment or Purchase.

Smelting and Refining Works:  
Electrolytic Copper Works:

NEWARK, N.J.

Buena Fe Sampling Works:

Agency, SABINAS COAHULLA.

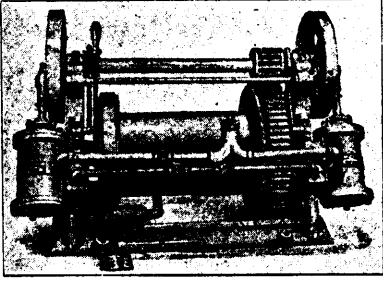

**DOUBLE 5 X 5 HOISTING ENGINE**  
For Steam or Compressed Air.

## THIS TYPE LEADS . . . . .

Specially designed for light surface hoisting and for underground work in stopes and winzes. Some of the Western Mines now using them are as follows:—

- B. C. GOLD FIELDS, Rossland, B.C.
- BLACK DIAMOND MINE, Ainsworth, B.C.
- WEST KOOTENAY POWER & LIGHT CO., Nelson, B.C.
- IRON MASK GOLD MINING CO., Rossland, B.C.
- LE ROI MINING & SMELTING CO., Rossland, B.C.
- CENTRE STAR MINING & SMELTING CO., Rossland, B.C.
- ATHABASCA GOLD MINING CO., Nelson, B.C.
- DUNCAN MINES, Nelson, B.C.
- GREEN MOUNTAIN CONSOLIDATED MINING CO., Rossland, B.C.
- IRONSIDES MINING CO., Greenwood, B.C.
- KING SOLOMON MINE, Greenwood, B.C.
- RUTH MINES, Nelson, B.C.
- MCLEAN BROS., Brooklyn, B.C.

This type of Engine is carried in stock, for immediate shipment, at Rossland Warehouse Eastern customers promptly supplied from the Factory.

## The Jenckes Machine Co.

Write for  
Catalogues  
and  
Prices.

27 LANSDOWNE ST.

SHERBROOKE, QUE.

Branch Offices  
in the  
Principal  
Cities.

## M. BEATTY & SONS,

Welland, Ontario.

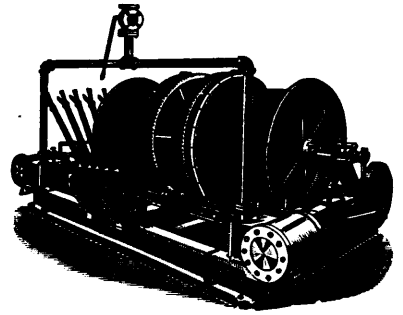

MANUFACTURERS OF

Dredges, Ditchers, Derricks and Steam Shovels for Dredging, Dykeing, Ditching, GOLD MINING, Etc., of various Styles and Sizes to Suit any Work.

MINE HOISTS, HOISTING ENGINES, HORSE POWER HOISTERS, SUSPENSION CABLEWAYS, STONE DERRICKS, GANG STONE SAWS. Submarine Rock Drilling Machinery.

Centrifugal Pumps for Drainage Works, Pumping Sand, Gold Mining, Contractor's Use, &c.

WIRE ROPE AT MARKET PRICES.

AGENTS:

**E. LEONARD & SONS**

MONTREAL, QUE.

ST. JOHN, N.B.

**B. GREENING WIRE CO.**  
(LIMITED)  
WIRE MANUFACTURERS  
& METAL PERFORATORS  
**HAMILTON  
& MONTREAL.**

## Wire Screens

FOR EVERY CLASS OF MATERIAL.

Perforated metal of Steel, Copper, Brass, Zinc, for all purposes. Special attention given to

**MINERS' REQUIREMENTS.**

# Pumps

& HYDRAULIC MACHINERY

STOCK SIZES ALWAYS ON HAND.

Drawings and Estimates Promptly Furnished.

**THE NORTHEY CO. Ltd., Toronto, Ont.**

18th YEAR OF PUBLICATION.

# The CANADIAN MINING REVIEW

Established 1882

THE OLDEST AND ONLY OFFICIAL MINING AND ENGINEERING JOURNAL PUBLISHED IN THE DOMINION OF CANADA.

B. T. A. BELL, Editor and Proprietor.  
Secretary, Canadian Mining Institute, etc.

Published Monthly.

OFFICES {Slater Building, Ottawa;  
Windsor Hotel, Montreal.

VOL. XIX., No. 1.

JANUARY, 1900.

VOL. XIX., No. 1.

## The Yukon Royalty.

In a recent issue we published the petition of the representatives of the British and Canadian companies interested in mines in the Yukon District, asking for a reduction in the royalty on the output of gold.

This high royalty of ten per cent. on the gross output of each claim, together with the very heavy penalties to which the mine, as much as the individual mine owner, becomes liable in case of non-payment, is certainly one of the chief reasons why so little foreign capital has been invested in the Klondike gold fields.

The most reliable and conservative reports that have so far reached us, based on returns from the mint and the banks, place the total output of gold from the Klondike for this year at a value of from 16 to 17 millions of dollars, and it is possible that it may exceed this amount by two or three millions. The reports currently published in the press, based on telegraphic returns from the Commissioner of the Yukon Territory, state that the royalty collected up to the first of November last is about \$730,000, which would represent an output of \$7,300,000 plus \$5,000 on every claim from which gold to that amount has been taken, amounting probably to \$2,000,000 more, giving a total output from which royalty has been collected of \$9,300,000, and leaving \$7,000,000 more on which no royalty has been paid.

To make even this very imperfect collection a large number of officials were employed. Many of the Mounted Police, both officers and men, who had been doing service along the trail from Dawson to the Coast were ordered to Dawson before the ice went out of the Yukon River in the spring, and were distributed along the gold-bearing creeks, both to act as detectives and to enforce the payment of the royalty. They doubtless did their work faithfully, as the Mounted Police always do it, but in spite of their utmost endeavours they did not succeed in collecting royalty on much more, if indeed they collected it on any more, than half the gold mined during the season. In view of the fact that royalty had not been collected on half the gold mined in 1898, the Government no doubt did its utmost, and must have gone to large expense, to collect the royalty this year, but the result cannot be other than thoroughly disappointing. It will, indeed, be hardly possible for the Government to collect royalty from a larger percentage of the output that it collected this year, without greatly increasing the number of men employed in the collecting, and therefore greatly increasing the expense. Then as the area over which mining operations are carried on becomes more and more extensive, the task

of watching the mines, even in the imperfect manner in which they are watched at present, would become greater and greater, until a large proportion of the royalty would be used up in the collecting of it, so that the miners would be groaning under a very excessive tax, which the country would be deriving but little benefit from it. This tax law has thus been fully tried for the past two years and has been found unworkable, and each year it will prove more expensive in collection, and consequently less effective in raising a revenue.

It is true that each miner is obliged to make a sworn statement of the output of his mine, and no one can say that the penalties for making false returns are not sufficiently heavy, involving as they do, not only the loss of all rights to prospect a mine again in Canada, but also the forfeiture then or at any subsequent time of the claim for which the false return was made.

Of course the true returns from most of the mines can never be known, as usually very few persons are present at the clean-ups, and the sluices and rockers are cleaned up far too often for a Government official to be present each time. But if the correct outputs could be proved, and the penalties for making false returns were imposed, what would be the result? Very many of the most skilful miners and prospectors would be driven out of the country, as doubtless many of these men have made false returns, for their lives of hardship and endurance in the wilderness has not cultivated in them any great respect for the tax-gatherer. These men have made the Klondike country what it is today, and without them, or men like them, the rest of that great northern land must remain a useless wilderness. Besides driving out of that mining country many of its most valuable inhabitants a great number of rich claims would be forfeited to the Crown. Many of these have changed hands in good faith, and are now owned by men who have committed no offence whatever. In many cases the man who had violated the law would be out of its reach, while the innocent man within its reach would suffer.

If this penalty could be and were enforced there would be very general consternation among the mine owners, property values would fall, and no one would think for a moment of investing capital in properties that had been worked, or even prospected, at all, for he would have no certain guarantee that the mine might not be confiscated by the Government at any time. The penalties are therefore such as no civilized Government, having the interest of the people governed at heart, could possibly inflict. Still the Government has power by law to exact these penalties, and the very fact that it has such power renders the title to any mine in the country imperfect and insecure.

That a ten per cent. royalty on the gross product of the mine,



added to the other heavy charges and expenses in that northern country, is in most cases an excessive tax, very few who have visited the Klondike District will deny. A few of the richest claims have paid it, and have still yielded large profits to the owners. But the pioneers in any successful enterprises often get large returns on their ventures, and considering the difficulties to be encountered, the prizes gained in the Klondike have been neither very numerous nor inordinately large. Let them be as large as they may be the country will gain from them both directly and indirectly. Directly, by establishing a centre of population and civilization in a new and remote portion of the Dominion, a population which will be both politically and commercially in touch with the older parts of the country, and by its very existence will render the country richer and stronger. It will also form a centre from which a population can spread out in all directions and gradually people these parts of the Yukon and possibly also the McKenzie district which are capable of supporting permanent settlements. Indirectly, the rich prizes act as incentives to others to explore the unknown parts of Canada, and search for and find its hidden mineral wealth. Thus, hundreds of thousands of square miles may be explored, and rich discoveries may be made, in regions which, if left to the few exploring parties sent out by the Government, might remain unknown for centuries. While extending the knowledge of the mineral resources of the country these prospectors are expending their capital in the country, whereas explorations made by the Government cost the country large sums of money. So, when rich discoveries are made, they draw population into the country far more effectively than any Government Immigration bureau, and without the expense of that organization. Instead, therefore, of attempting to tax these fortunate prospectors as much as they are able to stand, they should be shown every possible consideration.

We have seen that it has been found impossible to collect the ten per cent. royalty under the present law, that the penalties for evading the law would cause disaster to the country if they were imposed, that none but a few of the richest claims can afford to pay the royalty, and that these rich claims are the just rewards of the owners, and the greatest incentive to the opening up of more new country. As at present collected it presses very unequally on the various classes of people, for as its payments largely depends on the affidavit of the miner himself, it is collected fully from the honest man, while the dishonest man escapes.

The tax is all the more oppressively felt when the gold is taken to a local bank and the owner is charged three per cent. for having it assayed, and two per cent. more for a draft on any point in the south and east where he may wish to transmit money in the course of business. All these heavy charges, amounting to fifteen per cent., the miner escapes who quietly takes his gold out to the mint in Seattle or San Francisco and spends it altogether outside of the country.

It is possibly true that a revenue must be raised from the gold mined in that country, though it should be remembered that those who live there pay their share of the customs and excise duties of the country. In that case it would seem clear that the gold itself should be held liable for the royalty, and not the mines or the mine owners. In making the gold itself liable for the royalty the Government might proceed in one of two ways, either of which would yield an assured revenue on the total output of the mines. One way would be to place an export duty on all the gold mined in the Klondike, and as all the gold must be sent either up or down the Yukon River, on which customs-houses have already been established, the duty could be collected with very little additional difficulty and expense. The other way would be for the Government to establish an assay office in Dawson at which all gold would be assayed and the royalty collected, or

if anyone wished to export his own gold he could do so after it had been presented at the assay office, the royalty deducted, the gold-seal sealed with the official seal, and a royalty certificate granted. Either of these methods would effect alike, and a very much smaller tax would raise a revenue quite equal to that now raised by the abominable 10 p.c. royalty.

### Reckless Mining Investments.

A direct result of the widespread activity in all branches of business during the past year has been to increase investments in mining properties, and Canada has enjoyed her fair share of the improved conditions. Many new prospects have been opened up, companies have been formed, and mills erected. Such activity has not been witnessed in a decade, and there has never been a better opportunity presented for establishing a permanently productive gold mining industry. In the face of this it may seem ungracious to play the part of a pessimistic critic, but one fact stands out so prominently that attention must be called to it, lest we fail to profit as we should by the present boom. There is nothing more hurtful to the growth of legitimate mining operations than the reckless investments made during a period of inflated prices. These occur as a sort of side issue in connection with the larger commercial movement of the time, and are subject to the vicissitudes of trade and of the stock market. So far as iron and copper are concerned this close relationship is inevitable but the production of gold should not be influenced by the status of ordinary industrial enterprise. The demand for gold is universal and practically unsatiable. Investments in gold mines should be attractive at all times, and but for foolish ventures the growth of this branch of mining would be continuous.

There is a large portion of central Canada, lying mostly in Ontario, which can never hope to support any considerable population unless its mines become productive. The whole Dominion is interested in this result, for the existence of a thousand miles of unproductive territory midway between the east and the west means that the lines of communication through it are charged with expenses which must be wholly borne by the population on either side, and this is a permanent disability of a rather serious sort. Throughout this region are occurrences of gold and copper, which have constituted the basis for many mining companies, most of which in the past have come to grief, and the question arises whether the new crop of companies has been sown with wiser judgment than in the past. In so far as these new enterprises are frankly engaged in development work, we have nothing but praise and encouragement to offer. Development, thorough, patient, prudent development, is needed above all things. But we have only censure for those who blossom out with crisp stock and brilliant prospectuses as full-fledged mining companies, in advance of proper preliminary safeguards in the form of exhaustive development work. When the public is invited to subscribe to the stock of a corporation there should be some visible and intrinsically valuable basis for it. The so-called "industrials" rest upon a less secure foundation than a mine should. The demand for the product is known and the cost of production can be calculated. The volume of business and the profits obtainable depend upon the ability and energy of the management. If unsatisfactory, the management can be changed with possibly beneficial results. But a mine either exists or it does not. If the ore is not there no reform in the office personnel can save the investor's money.

Manifestly then there should be ore in sight sufficient to warrant the proposed expenditure for realizing upon it, before a company could legitimately claim to be more than a development concern. The dis-



tion is real and important, and considering that mining ventures are habitually thrust upon an unsuspecting public by promoters who either intend to swindle their victims, or else are so ignorant of mining that they do not realize the absurdity of their claims, it would seem proper in the interests of all that laws should be enacted prohibiting the issuance of mining stock, except for development purposes, when there was not ore in sight sufficient to cover the initial investment for property, plant, and equipment. The result would probably be to turn most of our mining corporations into development companies, but this would be a distinct gain. If men wish to take chances, let them do so, but with a full knowledge of the risk. Legitimate mining is not risky. The element of uncertainty is less than in any other form of enterprise.

A properly developed mine should have ore reserves sufficient to constitute a basis for operations for years ahead. It should at least have enough in sight so that the company may "come out even." And let it be understood that "ore in sight," means ore of which three sides are visible, so that accurate measurements of quantity and estimates of value may be made.

In this sense the developed gold mines of Ontario may be counted on the fingers of one's hand. In view of this, and the reckless speculation in so-called mining shares, the need of protective legislation is plain. It would be a step forward in the development of a permanent and profitable mining industry.

#### The Ophir Decision.

We understand that an appeal has been lodged on behalf of the Ontario Mining Company from the decision of the Chancellor of Ontario, an account of which was given in our last issue. While the result of the appeal will, under the facts found by the trial judge, only affect the parties to the litigation, yet it is clear that the principles set forth by Sir John Boyd as having been decided by the Imperial Privy Council, are of great importance to those interested in the mining industry, especially in that part of western Ontario, which was formerly known as the disputed territory.

The decision does not deal with the Indian Reserves set apart before Confederation. The patents of lands contained in such Reserves are to be issued by the Dominion Government, but it remains an open question as to whether the Dominion Government have authority to deal with the precious metals even in Reserves set apart before Confederation. The decision in the case of the Ontario Mining Company proceeds upon the fact found, that there was no acquiescence by Ontario in the selection of Sultana Island as part of an Indian Reserve, and therefore, the ultimate decision in this case will not decide the disputed points as to lands undoubtedly included in the various Indian Reserves set apart in the disputed territory.

It was claimed on behalf of the Ontario Mining Company that the precious metals in such Reserves had been promised to the Indians by the Dominion Government, and that the Dominion must keep faith with the Indians. On the other hand, the title to such precious metals was granted to the Provinces by the British North America Act.

From the standpoint of the mining industry the importance of certainty in such matters is extremely great. The amount of capital required for mining in Canada is so large, that if there is any dispute as to title nothing can possibly be done. It is said that some of the important mineral deposits in North-west Ontario are contained within the boundaries of the portions of territory set apart by the Dominion Government for Indian Reserves.

These questions as to the general Reserves remain open, and in the present condition of affairs a person buying or dealing with mining

property, has to be certain at his own peril, that the mine is not contained within the limits of land assigned to the Indians by the Dominion Government, if the Province has concurred in the selection.

All these matters should either by concurrent legislation or by the two Governments be speedily arranged, so that the mineral resources of Western Ontario may be developed without any difficulty from uncertainty of title.

From the the standpoint of the miner, it is important that all patents should be issued by one undoubted authority, and that in order to ascertain his title a miner should not be obliged to solve legal riddles about the proper construction of the British North America Act.

## EN PASSANT.

The peat industry in Ontario is promising to assume important proportions, as a result of the energetic efforts of the Canadian Peat Fuel Company of Toronto. Plants have been established at Perth, Brockville, Picton, Galt, Kirkfield, Beaverton, Barrie, and Stratford, using the Dickson briquetting machine, controlled by the Canadian Peat Fuel Company. Considerable difficulty has been experienced in properly drying the peat before compression, and this has led to some discouragement on the part of the companies which have been experimenting on the production of this fuel. At Kirkfield a drying plant on the Cumner system, using revolving cylindrical dryers, will soon be in operation. This is something of an innovation, as it has usually been considered that the effort to expel the moisture from so highly absorbent a material as peat would involve important losses of volatile combustible matter. One sample of Ontario compressed peat gave on analysis:—

Moisture.....	12.00	per cent.
Volatile combustible .....	58.20	"
Fixed carbon .....	26.00	"
Ash .....	3.80	"
	<u>100.00</u>	

An estimate of the heating power of this fuel, based on the method proposed by William Thompson (Proc. 7th Conv. Can. Elect. Assoc.) gives 7,201 calories. This is a surprising result, even when it is considered that no allowance has been made for heat rendered latent by the moisture of the peat. The calorific power of the ordinary air dried peat in Europe, as there prepared, is about 3,000 calories. The Ontario Bureau of Mines is preparing a special report on the peat industry, which will be particularly valuable and interesting at this time. The companies now operating are said to be able to sell all they can produce at from \$3.50 to \$4.50 per ton, according to their distance from the lake markets for coal.

Recent advances in the chlorination of gold ores are bringing this process up to such an unexpected efficiency, that in many places it is becoming a strong competitor of the cyanide process, not only on the side of high extraction, in which it is apt to excel, but in point of large capacity also. One of the most startling developments of chlorination on a large scale is reported from the Mount Morgan mine in Australia. The oxidized ores are roasted in continuous revolving calciners. The pyritic ores are roasted in a modification of the old German shelf furnace, designed by Mr. G. A. Richard, General Manager of the Mount Morgan property. These carry about 15 per cent. of sulphides, and are said to be difficult to roast "dead." Crushing is done in ball mills, thus avoiding too large a percentage of fines, producing a more uniform product than could be obtained from the stamp mill. After roasting and cooling, the ores are conveyed automatically to the treatment vats, which are of large size, 4 feet

deep, and oblong in shape, being made of concrete and cement. The filter bed consists of gravel and sand, no cloth filter between this bottom and the overlying ore being used. The chlorine is generated in the ordinary way with manganese dioxide, sulphuric acid, and salt, but the chlorine is absorbed in water contained in large, cement lined, covered tanks. This solution of chlorine water is then conveyed through earthenware pipes to the ore tanks, where it is applied in a manner similar to that with cyanide solutions. The auriferous solution from these vats is passed through charcoal precipitating filters. This system is said to yield more economical results than cyaniding. It will be noted that no neutralization of chlorine in the solutions is necessitated by the method of precipitation employed, but this advantage might easily be offset by losses in charcoal ash, unless downward combustion of the charcoal were adopted.

In Colorado, where the chlorination process has been brought to a high state of perfection by Mr. John E. Rothwell, the free chlorine in the leach liquors is neutralized by ferrous sulphate, instead of by  $\text{SO}_2$  as formerly done, about 75 pounds of the sulphate being added to 30 tons of the solution. The ferrous sulphate is obtained as a by-product from the generation of the hydrogen sulphide which is there used as the precipitant for the gold.

The gold slimes are collected, filter-pressed, and roasted, after which they are melted in graphite crucibles with a flux consisting of borax 60 parts, bicarbonate of soda 30 parts, and silica 10 parts, about 1 part by weight of flux being used with 2 parts of the roasted slimes. The resultant slags are remelted with litharge and a reducing agent, yielding a base lead bullion, and the slags from this final melt are then shipped to the smelter. The ashes from the furnace are also shipped to the smelter, as is usual where smelting works are available within reasonable distances.

The losses of gold in the ashes of melting furnaces are so important that oil burners are coming into vogue, being economical from every point of view.

In the design of roasting furnaces for the treatment of the gold slimes from either the cyanide or chlorination processes, too great care can not be taken to prevent losses in the fumes and dust carried off from the roasting chamber. The vents from these chambers should never lead directly into the flues from the firebox, but should connect with suitable cooling chambers, which may be constructed underneath the hearth of the furnace, or better still built entirely outside of this structure, with a flue opening into the main furnace flue farther on. A series of baffle-walls in the cooling chamber will do fair work in checking the escape of the gold, but a more effective device is a series of sheet iron plates, about No. 14 Birmingham gauge, suspended vertically not more than  $\frac{1}{8}$ th of an inch apart, completely filling the flue through which the fumes must pass. Two sets of these, placed so as to break joints with each other, each set being 2 feet long, and their longer axes parallel with the longer axis of the flue, will effectually preclude loss of any dust. In a chamber one foot square and four feet long, containing these baffles, there are presented to the gases 472 square feet of frictional surface.

One of the simplest devices for the concentration of sulphides from the pulp issuing from a stamp mill is the canvas floor, which has been growing in favor steadily since its introduction in a number of California gold mills a few years ago. It is there employed as a final treatment after concentration on Frue vanners, being an improvement upon the old blanket sluices formerly used. The introduction of such highly perfected concentrators as the Bartlett and Wilfley tables renders such treatment less necessary, but even with these there is

often a considerable loss of fine sulphide if the pyrite in the ore has a tendency to produce slimes. The canvas floor consists of a platform inclined from  $1\frac{1}{2}$  to  $4\frac{1}{2}$  in. per foot, according to the character of the material to be treated, 75 feet long, covered with No. 7 duck, the floor thus covered being divided into long parallel sections by narrow wooden strips tacked on 20 in. apart. Six such sections will take the pulp from 5 stamps. The launder bearing the tailings from the concentrator delivers these into a V shaped feed-box running along the head of the canvas floor, the pulp issuing through two 1 in. holes bored opposite each section. The flow is regulated by wooden plugs. Just above these feed-holes is fastened a fresh water feed trough, from which the requisite amount of water is added to carry off the quartz grains, leaving the pyrite adhering to the canvas. By varying the inclination of the floor, and the amount of fresh water fed, a very delicate adjustment may be obtained. A launder at the lower end of the floor carries the tailings to a second canvas floor, similar in all respects to the first. At the end of a half hour the pulp feed is shut off from the first section, the clear water being permitted to flow until only the sulphides remain. Then a sheet-iron tray is placed across the tailings launder to carry the sulphides from this section over to the concentrates launder, when the attendant, usually a boy, sweeps the concentrates down with a broom. The pulp is now admitted again to this section, and the second section is cleaned in like manner, thus proceeding in rotation. One boy can attend to a floor of 12 sections, taking the pulp from 10 stamps. Classification of the pulp will give very clean work, the closer the classification the better. The old-fashioned inlet-discharge classifier, which can be made by any carpenter, will serve excellently, and when once adjusted will require no attention. In the canvas plants in California the launder from the vanners discharges the pulp into the center of the feed trough, from which point it flows both ways, the velocity of the current serving to carry the finer particles to the outer sections of the floor, while the coarser material finds its way to the central sections. In this manner a rude sort of classification is effected, which is better than none.

The quantity of mica exported from the mines in Ottawa County, Que., was 1,011,443 lbs. estimated by the Customs at \$156,195. As considerable quantities go outwards in small bulk for which no declaration is required, the value exceeded this amount. These returns are the highest in the history of mica mining in this district. No returns of the production in Ontario have been received, but we quite expect they also will show a considerable increase over previous years.

The mica output of the United States shows considerable improvement. The sheet mica increased from 82,676 lbs. in 1897 to 129,520 lbs., a gain of 56.66 per cent. in 1898. The value increased, though not in the same proportion as the product. It rose from \$80,774 in 1897 to \$103,534, or 28.18 per cent. In addition there were sold 3,999 tons of scrap mica for use in the manufacture of lubricants, wall papers, boiler coverings, &c., valued at \$27,564, as compared with 740 tons in 1897, valued at \$14,452.

Some interesting facts concerning the nickel production of Ontario are presented in an official note on the mining and treatment of nickel ores in the Province of Ontario, by Mr. Archibald Blue, and issued by the Ontario Government this month. Mr. Blue says:

"Much progress has been made in the methods of treating the copper-nickel ores of Sudbury since the first smelting works were established there. None of the processes at that time in use were exactly suited for our ores, and many costly experiments had to be made before economic results were reached upon a commercial scale.

It is probable that improvements will continue, and that larger economies will be effected; but in the present state of the industry there is no reason to doubt that the outlook is hopeful. The oldest establishment (organized under a charter granted by the Federal Parliament in 1886) has five furnaces in blast, smelting an aggregate of 400 to 500 tons of ore daily, and the whole of its matte product is being shipped to refineries out of the country for extraction of the nickel and copper. Two other establishments are completing plants for treating large bodies of ore by new processes, and are hopeful of winning other valuable contents of the ore besides the nickel and copper. One of these processes aims at recovering the sulphur and iron and producing ferro-nickel direct; and the other aims at recovering the precious metal, small percentages of which the ores are known to carry. A wealthy English capitalist and scientist, who has spent several years in perfecting a new method of extraction, has recently acquired from private owners a number of locations which he is developing, and it is understood that he will erect smelting works next year. It may therefore be assumed with confidence that the industry has passed the stages of development and experiment."

In the seven years 1892-1898 the quantity of ore smelted and reduced to matte in the Sudbury district was 591,852 tons, and the estimated metallic contents were 29,705,000 lb. nickel and 34,570,500 lb. copper. At the selling price of matte at the furnaces, which is in form in which it is exported to the refineries, the total value of the nickel product for the seven years was \$3,294,060, and of copper \$1,302,805, or a total of \$4,596,865.

The bulky volume just issued by the Geological and Natural History Survey of Canada, again bears testimony, if any were needed, to the great value and utility of this important, and sometimes overlooked, branch of the public service. The new issue which covers the investigations of Dr. Dawson's staff during the year 1897, contains something over 1,000 pages, and is accompanied by eight maps. The Director calls attention to the fact that 5,843 separate publications of the Survey were sold during that period—a number nearly twice as great as that for 1896, and very much in excess of that in any previous year. These sales are in addition to the large number of reports and maps gratuitously supplied to public institutions and exchanges and often include publications issued many years ago. One of these days we hope to see this valuable institution properly housed. The present building besides being wholly inadequate to the requirements of its very fine collections, is far from being safe. A Government grant for a building more in harmony with the extensive operations of the Survey should no longer be delayed.

The shipments of minerals over the Quebec Central Railway during last year were:—

Asbestos.....	13,898,111 tons.
Chromite.....	1,980,780 "
Granite.....	483 "
Flagstone.....	1,326,888 "
Brick.....	7,931,610 "
Lime.....	8,066,978 "

All Canadian mining men should make a note of the meetings of the Canadian Mining Institute which are to be held in Montreal on the 7th, 8th and 9th March next. A very fine programme has been arranged. A single fare rate has been given on all Canadian railways. The members will hold their annual dinner at the Windsor on Friday evening, the 9th March.

The production of asbestos in the United States still continues to be insignificant, being wholly confined to California and Georgia. The value of the production in 1898 was \$10,300, and in 1897 \$6,450. Canada exported to the United States from its Quebec mines asbestos to the value of \$268,264 in 1897, and in 1898, \$300,533. During 1899 the output from the mines of the Eastern Townships was about 14,000 tons. No figures have been received from Danville.

In answer to representations made on behalf of the Canadian Mining Institute, the Hon. Mr. Tourgeau, Commissioner of Colonization and Mines for the Province of Quebec, has stated that the exemption from taxation on mineral property in that Province, which expires in July next, will be extended for another period of ten years.

A Committee of the Federal Government has been appointed to consider the demands being made in certain quarters to impose an export duty on nickel, with the object of forcing the refining of this metal in Ontario. Notwithstanding the great pressure being brought to bear upon the Government, it is extremely unlikely that any such short sighted legislation will be approved by the Administration.

Messrs. E. R. Faribault, A. P. Low, and C. P. Willimott, have been appointed by Dr. Dawson to take charge of the Mineral Exhibit being sent to Paris. The collection, particularly that from the west, is a very fine one, and embraces 1,500 exhibits.

Owing to pressure upon our space this month our annual review of the Coal trade is held over until next issue.

### A Romance of the Middle Ages.

(From the *Critic*.)

I.	IV.
It was in the Middle Ages, It was somewhere near Peru, Someone found a silver sixpence In a field—this tale is true! Which to somebody he mentioned Who was going out to dine; In a week it had expanded From a sixpence to a <i>mine</i> .	Then the public they invited, With a lot of tender soap, To come and see that sixpence Through a monster microscope! And the capital was stated At a hundred thousand pounds, Into five pound shares divided— How refreshing all this sounds!
II.	V.
Then a company promoter, And surveyors by the score, With eminent financiers, Came and landed on that shore. Then they spent a month prospecting With a magnifying glass, Building up with many chuckles Quite a cheery little farce.	Then the public rushed to buy them, Till a five pound share cost eight, And a lot of people murmured That <i>they</i> always were too late. Thus this company was floated In a month or two they say; But the capital it floated In a very different way.
III.	VI.
They returned to Merrie England, And they nursed their little scheme, Till they brought out a prospectus, Which was quite a poet's dream! For it told of wealth enormous Lying buried in the ground, And which only wanted raising, Having been already found.	For the finder of the sixpence, Well, of course <i>he</i> took a third, The promoter took another, Then the lawyers—'twas absurd— The surveyors and financiers Took as much as it would yield, Thus leaving the investors With the sixpence and the field.
VII.	
This was in the Middle Ages! You'll remember that, I trust, When the world was very wicked, And man's morals apt to rust; Now, of course, it couldn't happen, Men are good and true and kind, And I've not the faintest notion What has brought it to my mind.	

## ONTARIO NOTE AND COMMENT.

There is one man in Ontario who has faith in her resources, and who is proving his faith by his works. His name is Francis Hector Clergue, and his address is Sault Ste. Marie. Mr. Clergue and the company composed of Philadelphia capitalists, of which he is manager, claim to have a capital of twenty millions, which they are anxious to invest in industrial enterprises in this Province. They began several years ago by acquiring control of the Canadian half of the immense water power formed by the descent of the St. Mary River from Lake Superior. The development of this power was an undertaking commenced by the town of Sault Ste. Marie, but the task was too heavy for the municipality's meagre finances, and was relinquished with a sigh of relief to the new company on its own terms.

The first utilization of the water power was in a large ground-pulp mill, for which the canal on the Canadian side formed an ideal site. To supply their mill with pulp wood, the company procured a concession of spruce territory from the Ontario Government on favorable terms, and have now in course of construction an equally large mill for the manufacture of sulphite pulp alongside their old one. A railway from Sault Ste. Marie to Dalton Station on the main line of the C. P. R. is another of the company's projects, one object of which is to open up the large spruce forests which are believed to exist in the little known country lying between Sault Ste. Marie and the C. P. R. The ultimate destination of the railway is James Bay.

Not the least interesting, nor the least bold, of the enterprises in which Mr. Clergue and his associates have embarked, are those which are connected with the mining industry. Experiments with a new process for the treatment of nickel ore are said to have demonstrated its effectiveness and its ability to save not only the nickel contents of the ore, but also the iron and sulphur, which in the current methods are got rid of as waste. Ferro-nickel and nickel steel can be produced, it is claimed, direct from the nickeliferous pyrrhotite, the only other ingredient which it is necessary to add being iron ore, in order to maintain the iron and nickel in due proportions. The sulphur will be used in the production of sulphuric acid, of which large quantities will be required in the sulphite pulp mill. Apparently the only constituent in the ore which will find its way to the slag heap is the rock matter. The estimated cost of the reduction works and refinery is about a million dollars. Nickel and copper ores will be purchased from other producers, but the company will mainly rely upon their own deposits in the township of Creighton, where the ore is high in nickel and low in copper.

The company's chemical works for the production of sulphuric acid will, it is believed, involve a cost of half a million dollars, and a large plant for the manufacture of bleaching powder, caustic soda and alkali products from salt, costing a million and a half, constitutes another item on this pretty extensive programme.

The chief feature, however, is a great steel mill, which is to be devoted principally to the manufacture of nickel steel rails. By the new process the cost of nickel steel will be reduced to a figure which will make it available for rails. This figure is put at something like \$30 per ton, and as a nickel steel rail will surpass in wearing qualities the ordinary steel rail as much if not more than the steel rail surpassed the iron one, the demand for nickel steel rails at an equality of price is expected to be enormous. Indeed, the prospect which \$30 per ton nickel steel rails will open up to railway managers and financiers is too attractive to seem a thing of this earth. Yet Mr. Clergue not only

asserts that this bright vision can be realized, but that he will realize it himself at Sault Ste. Marie, Ont., in a very short time, and he is investing his own and his company's money in proof that he believes what he says. The apparent impossibility of the achievement will be seen when it is remembered that the nickel steel armour plate for the new United States battleships is costing about \$400 per ton.

It is not necessary, or even advisable, to become too enthusiastic over so great an advance as nickel steel at \$30 per ton would imply, until the article is placed on the market, where incredulous eyes may see it, and doubting hands may handle it, but it is evident that if Mr. Clergue's anticipations are realized, the field for the employment of nickel steel will be immensely widened, and that for all purposes in which toughness and strength are requisite, it will be freely substituted for ordinary steel. What such a state of things would mean for the nickel industry of Ontario may be conceived. Mr. Clergue adds that he has made contracts for the delivery of ferro-nickel in large quantities to Krupp of Germany.

An abundant supply of good iron ore is essential for the production of steel upon a large scale. This the Clergue interests have apparently secured in the Helen brown hematite mine, near Lake Wawa in the Michipicoton district, where large bodies of good ore have been shown to exist. Diamond drill borings on the property are in progress, and it is said have already proven the presence of some 4,000,000 tons of ore, with development work still going on. A railway some nine miles in length is now being built from Gros Cap Harbor to the iron mine, and indeed, is nearly finished, the work having been greatly aided by the present open winter. About 500,000 tons of ore will, it is said, come out on the opening of navigation in the spring. The quantity of iron ore raised in the whole of Ontario during 1899, probably, did not much exceed one-twentieth part of this output. Other locations in proximity to the Helen mine, owned by A. C. Ely, of Cincinnati, are also said to contain large bodies of ore.

Recent explorations north of Batchawana Bay and on Hunter's Island, have brought to light several deposits of iron ore which may be valuable some day, but which for want of transport facilities cannot at present be made use of. A by-law to bonus an iron blast furnace at Fort William to the extent of \$50,000, was submitted to the ratepayers of that town on 1st January. An overwhelming majority carried the by-law, and also one for granting \$25,000 in aid of a copper smelter and refinery. The furnace and refinery are to be erected by the Mattawin Iron Company, in which James Hammond of Fort William, Folger Bros. of Kingston, and Mackenzie, Mann & Co., are interested. The iron ore for the furnace will be brought out by the Ontario & Rainy River Railway, now being constructed, from properties on the Mattawin and Atikokan ranges, and the copper ore from Round Lake, near Lake Shebandowan. These deposits are owned by the above named parties.

The Government diamond drill has been engaged by the Mattawin Iron Company to explore some of its iron ore bodies near Finmark Station on the C. P. R.

We have in preparation an illustrated supplement of the gold mines of Western Ontario, including a large projection of the Bag Bay District, specially prepared prepared for THE REVIEW by Mr. Theo. Briedenbach, manager of the Sirdar mine. This plan will show the mines and locations in that very promising section.

Two fatal accidents, both in gold mines, within the last few weeks, serve as a reminder of the risks which the miner has to face in his

calling. R. Burnett and C. Mitchell were mucking on the fourth level of the Golden Star mine, when a mass of loosened ore descended upon Burnett and killed him outright. Mitchell escaped serious injury. At the Sultana the accidental explosion of a considerable quantity of dynamite in the sixth level, caused the fall of large quantities of rock from the sides and roofs of the workings. Some fell on Ole Olson and Charles Tunstan, and instantly killed them both. Timbers in the main shaft were badly shattered, the floor of the shaft house was blown up, and other damage was done by the concussion. Accounts differ as to the quantity of dynamite exploded, some placing it at 250 lbs. and some at 100 lbs. Why so much of the explosive was required in the mine at one time is far from clear.

There are large deposits of talc in Ontario, and a mine of this material has been opened at Madoc by Mr. J. E. Harrison, who ships it to Newark, New Jersey. The quality of the talc is pronounced by the consignees to be first-class, and there is a good demand for it. Mr. Harrison expects to ship about five carloads per month during the winter, and to largely increase his output when spring opens and shipments may be made by boat from Belleville.

The new Commissioner of Crown Lands, Hon. E. J. Davis, and Mr. A. Blue, Director of Mines, visited Sudbury about the middle of January to get the opinion of the mining community there on the mining laws generally, and in particular on the new policy of the Government in seeking to compel the refining of nickel and copper in the Province. The views of the Sudbury people as expressed at a public meeting were decidedly adverse to the new departure, and resolutions were carried in favor of rescinding it and of returning to the main features of the mining law as it was previous to the changes of 1891. The abolition of royalties, a reduction in the amount of development work required, lower prices for mineral lands and larger grants for roads and railways, embodied the Sudbury view. Major R. G. Leckie, of the Canada Mining and Metallurgical Company, occupied the chair at a banquet subsequently given to Messrs. Davis and Blue. As a result of representations made during his visit to Sudbury, Commissioner Davis has agreed to establish a local mining office there for the convenience of prospectors and others having business with the Department.

The output of the Mikado mine for December was 691 ounces of gold from 848 (long) tons of ore crushed, and 273 ounces of bullion from 509 tons of tailings treated by the cyanide process. The total value, estimating the smelted gold at \$16.22, and the cyanide product at \$6.13 per ounce, was \$12,881.51. The yield for November was about \$1,000 less.

The zinc refinery at Hamilton is well under way, and it is thought that it will be ready to treat ore about April next. The Hoeffner Refining Company, which is composed mainly of Hamilton men, are the proprietors, and will use the Hoeffner process of refining zinc invented by Dr. Hoeffner, the metallurgist of the company. Ores will be available from the Zenith mine, near Rosport, north of Lake Superior, and also, from the Grand Calumet mine, Quebec. The company are also arranging for the erection of works for the refining of copper-nickel ore and the manufacture of nickel steel. If their present plans are carried out, the works will be on an extensive scale and will include blast furnaces and rolling mills as well as a refining plant. They will have a length of nearly a mile, and will require 22 miles of railway. English, German and American capital is interested. If these projects take tangible and successful form, Hamilton will have earned one more title to its soubriquet "the Ambitious City."

### In the Kootenay, B.C., District.

No. 1.

(By our Travelling Correspondent.)

The rich sands of Wild Horse Creek, running into Kootenay River on the south side of where Fort Steele now stands, attracted in 1863 the attention of a fur hunter who brought the news to Colville of finding coarse gold on that creek. An immense rush of prospectors and miners at once took place, and by May, 1864, four hundred miners had distributed themselves along its bars and canyons, for whose accommodation the Provincial Government constructed a rough trail. This wild highway of the mountains wound along the edge of a vast basin touching the tumbling waters of Trail Creek, and followed its noisy channel to the mining camp. Prospects were obtained there of \$1.00 to the pan, and 25c. to the shovel; nuggets were found in the gravel worth from \$2.50 to \$78.00, and ordinary claims were paying \$20.00 to \$30.00 a day per man. The excitement grew, and in August of 1864, Hudson's Bay Factor McKay reported 5,000 miners in the district. Within five years \$20,000,000 in gold dust and nuggets were taken out, after which the yield becoming exhausted the gold hunters scattered afar, and the trail became overgrown with the rank vegetation of that moist climate. But mining did not die with the decline of placer digging.

#### ROSSLAND CAMP.

Some twenty-five years later the experienced eye of one of a party of prospectors wandering over the old trail caught sight of a large ledge of mineral-bearing rock crossing this trail. Supplies were running short, and one of the party started for the nearest settlement, whilst the remaining one, picking his way through dense undergrowth, reached a point on Red Mountain where forest fires had bared its rough sides, and there discovered the bold iron cropping of numerous strong veins where he located, in the vicinity of what is now the city of Rossland, five claims now rated at a valuation in the aggregate of upwards of \$15,000,000. These prospectors, however, being poor, sold their claims for a trifle, and it was not till 1895 that the mines, opened on these claims, assumed an international reputation, and known as the Le Roi, War Eagle, Centre Star, Idaho and Virginia. For six years after the discovery of the iron-capped ledges on Red Mountain, the purchasers worked on under many difficulties, and the district was scarcely known to the outside world. But with the finding of a marvellously rich ore chute and another of pyrites, dividends were declared, and poor men suddenly became rich, and the world made a rush for the snow-capped peaks where such wealth was reported. In the winter of 1896-7 the primeval log-house settlement grew into an ambitious city, lots were sold at fabulous prices, utopian claims were recorded, and mining companies were floated with impossible capitalizations, shafts being sunk in barren granite where no mineral existed. Then followed the usual financial crash as the result of wild speculation, and Rossland trembled in the balance for its existence. Some of its residents, however, with a faith that was sublime, stood by the camp in the face of discouragement, and little by little confidence was restored. With the advent of 1898 dividends again began to be paid, shipments of ore assumed large proportions, and Rossland again developed, going steadily ahead until it has now reached unprecedented prosperity, and possesses a population of nearly 8,000 souls, and the comforts of many an older eastern city. The costly experience of 1896-7 showed that hap-hazard ignorant driving of tunnels and shafts could not compete with companies controlling large capital and employing only trained specialists—the only means of ensuring final success. The amount of heavy mining machinery in use there is unriv-

alled in the province, and power is derived from an electric plant on the Kootenay river, thirty-five miles distant. Transmitted with but little loss of energy, it is utilized in driving the air compressors that run the entire plant of the larger mines, and affords light where needed. The production of the five mines in 1898 reached 116,697 tons valued at \$2,801,758, assaying, besides iron and copper, from \$12 to \$20 of gold per ton, and it is asserted the yield for 1899 will more than maintain the record of the past.

#### NELSON DISTRICT.

Toad Mountain, nine miles south of Nelson, a rapidly growing city, is another of the wealth-yielding finds of a prospecting party searching for gold, who, meeting with indifferent success, resolved to abandon their search. Whilst looking for their horse, which had strayed to the top of a mountain when the warm Chinook winds had cut away the snow, one of the party stumbled across the outcrop of an ore remarkable for its brilliant rick peacock coloring. Through some technical irregularity the claim was subsequently "jumped," and it virtually passed out of the original discoverer's hands. In 1892 it was sold under the name of the "Silver King" to an English company, but what the vendor received has never been made public, but the only surviving party of the discoverers received \$25,000. This mine pays 7 per cent. interest on the preference stock, besides 15 per cent. of the ordinary capital in dividends. It is fully developed and equipped and the company has built the most complete smelter in the country out of its profits. Some eighteen miles south of Nelson is the town of Ymir, through which flows Salmon River, with Wild Horse, Bear and Quartz Creeks entering it. These drain a mineral district rapidly assuming a prominent position. English companies own the most promising mines, and it is asserted no camp in British Columbia has greater popularity upon the London Stock Exchange. The largest stamp mill in the Province has been erected at the Ymir mine, treating 100 tons of ore a day, and sufficient ore is in sight to maintain this rate for the next two years, with no further development. The Dundee and Porto Rico mines in the vicinity are giving large yields, the latter in one month extracting 590 ounces of gold from 542 tons of crushed ore. The output of the Ymir mines for 1899 is estimated at 1,600 tons per week, closely rivalling Rosslund. As fine claims lie undeveloped in the surrounding hills as any of those now so productive.

#### SLOCAN DISTRICT.

The Slocan district of Kootenay is another centre of activity, owing its present prominence to accident. In 1891 two prospectors left Ainsworth, a leading mining camp of a vast stretch of country extending west from the Rocky Mountains to Arrow Lakes. The towns of Kaslo, Three Forks, Sandon and New Denver, that now bustle with life and activity, were then unthought of. Proceeding to the top of the lofty mountains up the north fork of Kaslo Creek, one of the prospectors picked up an ordinary looking piece of rock the weight of which astonished him. Breaking it open, good looking galena was disclosed. They returned to Ainsworth, where on an assay being made the result announced a return of 174 ounces of silver and 75 per cent. of lead to the ton. This becoming speedily known, other parties set out to locate claims, but a compromise was finally effected for all to have an equal interest in all locations made. During their stay they located twenty-three claims, some of which have since turned out veritable bonanzas. Returning in the autumn with numerous samples, the high grade of which was ascertained by experts, a stampede took place from Ainsworth, which for a time became a deserted camp, there being only one person—a woman—left behind, but it was soon re-peopled. As the news spread, prospectors from camps far and near hurried into the mountains. It was no jaunting trip in those days,

and only the most experienced and rugged mountaineers could endure the hardships and the wearing toil. Three passes were found in the district, but so dense was the undergrowth that pack animals could not be employed. The mineral hunter was required to pack his blankets and supplies upon his back, and, thus burdened, toil through the tangled canyons and slowly scale the snowy summits. Because the ores were rich and at the surface, and the steep mountain sides permitting development by tunnels, the Slocan country became known as a "poor man's camp." In many instances the mines there have paid profits almost from the first shot. Some of them have paid millions of dollars. Capital quickly followed the prospector and the miner, and concentrating mills, tramways and towns have been built. During 1898 eighteen Slocan mines shipped crude ore and concentrates aggregating 30,057 tons valued at \$100 per ton, an annual yield of more than \$3,000,000. Of this output the Payne yielded 14,000 tons, the Idaho 4,000, the Ruth 3,250, and the Slocan Star 2,862.

#### BOUNDARY DISTRICT.

The Boundary Creek district, including an area of some 400 square miles, is said to show the largest veins of gold bearing copper ore in the world. Like many another rich mining district, it owes its beginning to placer mines. From the creek itself it is estimated \$50,000 was taken out thirty years ago, but the placers did not prove lasting, and the district was deserted without any attention to its enormous leads of quartz and iron. In 1886, other placer miners journeying through, found some likely looking quartz in Copper Camp, but this was not then followed up. In the year following, however, one W. T. Smith located a camp, and he is today one of the principal mine owners of that section of country. It embraces Kettle River, Grand Forks, and the famous Knob Hill mine near Greenwood, a rapidly rising new town. The Old Ironsides mine is near by, the ore in which grows constantly richer. Knob Hill produces almost solid ore, free from waste, the vein being over 400 feet wide. The Columbia & Western Branch of the C. P. Railway now reaching Greenwood will materially aid shipment of ore, and smelters are to be provided close at hand. The C. P. R. Co. has strong faith in the mines of the Kootenay, and evinces a determination to provide means for reducing the ores, looking for profit from hauling, and from the prosperity which follows settlement. The Kettle River, rushing through a narrow canyon with a descent of 125 feet, gives force estimated at 20,000 horse power, shortly to be utilized. Near Cascade City free milling ore is being developed, and Grand Forks, known as the "Gateway to the Boundary" country, is a rapidly growing town where a new smelter is about to go into operation.

The recent opening of the Crow's Nest Pass Railway, a branch of the main C. P. Ry. running to the Kootenay district, has opened a coal mining centre where large quantities of coke are now manufactured for use in the smelters. At Fernie, about half way along the line, one of the greatest coal deposits in the world is being worked, the product of which, tested by the British fleet of the Pacific station, has been pronounced superior to all other coal. The Company working it has some 70 or 80 bee-hive ovens, and plans the erection of 200 in all. It is developing 12 seams of coal, and the amount in sight is estimated to run millions of tons.

Volumes could be written if all the mines located as well as operating in the Kootenay were described, but with all this activity the vast district is to a great degree unexplored. Streams there are and canyons within the known mineral belt where the prospector has not yet been, and where doubtless as rich rewards await the toiler as any that have yet been won in the camps already described.



### The Silver Plating of Amalgam Plates for Gold Mills.

By ALLAN JAY CLARK, E.M.S.

When, during the summer of 1897, the silver-plated amalgam plates of the mill of the Homestake and Highland Mining Companies, at Lead, South Dakota, showed signs of wear, an interesting question presented itself. There were about three hundred of these plates, each 54" wide, the length varying from 8' to 12', the latter size predominating. On account of the probability of a considerable accumulation of values upon these old plates, as well as by reason of the heavy rates of transportation to eastern points, it was undesirable to ship these plates for retreatment: while their sale to a smelting company would have been equally inadvisable. On the other hand, the decreasing gold recovery as the silvered surfaces became worn was very pronounced and called for immediate action. It was in consequence decided to do the work at Lead, and the plant here described was accordingly installed.

The process of silver-plating is of course well known, but in his investigation of the subject the writer found that but little of the literature was "up to date," while much was wholly misleading.

Moreover, the particular problems presented by these plates, so long covered with mercury and amalgam, could only be ascertained by experience. As the use of silver plates seems to be steadily increasing in the mills of this country, it may be of use to collect the notes of the operations of the first year and to describe briefly the methods employed and the difficulties encountered.

*The Plant.*—The operations (with the exception of the preliminary cleaning) are performed in a single well-lighted room, 28' x 40', connected with the assay office of the company. In this room are the motor and dynamo, solution tanks, working bench, painting racks, furnaces and water connections; while a wide platform, extending around two sides of the building, provides a convenient storage place for many of the supplies, and is also used during the warmer months for the painting, thereby giving more room for the operators inside.

In the absence of steam connections, the necessary heat for dissolving the silver for the solution, for heating the cleaning bath of potash, etc., is obtained from a pair of low furnaces placed at the side of the room, the heated products of combustion passing through flues 3' 6" wide and 16" above the floor level. Over part of these flues is a hood, so arranged that it will carry off the nitrous fumes arising from the preparation of the solution, and will also, when the furnace is not in use, be available for the regular work of the chemical laboratory. A 2" pipe supplies the necessary water. The floor throughout is of cement, sloping from the walls to the centre, where a gutter carries the wash water, etc., to the drain. The power is taken from the main circuit of the company—a 110 volt incandescent light line—and drives a 7 H.P. motor, C. & C. make, especially wound, and directly connected with a dynamo, a Hanson & Van Winkle plating machine of 3 kilowatts and 500 revolutions. The foundations of the machine are of cement, raised about 2' above the floor level. Although these machines are in no way protected from the corrosive action of the acid fumes or from the dust of the assay office, they have required no repairs beyond the reshaping of the dynamo brushes and a renewal of those on the motor.

The tanks are three in number:

1. The solution tank, inside dimensions, 15' 6" x 30", is of red-wood, 3" thick, heavily strapped, and lined with a thick layer of asphaltum. To apply the asphaltum, the tank, after being put together was laid on its side, the molten asphaltum poured in gradually and ironed smooth. The handling of this large tank is achieved by use of a traveling crane, which gives access to every part of the room, and is

used as well for the daily handling of the amalgam plates. The spreading of these tanks when filled with solution is surprising, as much as 2½" increase of width at the centre having been noted. Great care must be exercised, either when filling or emptying, to correct this tendency with the straps. The tanks are set in pits 3' deep, cement lined, and open to inspection on all sides, so that any signs of leakage may be quickly discovered and repaired. As a precaution against leakage, however, the pits are made large enough to carry all the solution in the tank, while at a convenient place a slightly greater depth is provided to pump out all solution so escaping.

2. The so-called stripping tank is similarly constructed and mounted. This tank was built for use in cleaning the old plates, and proving a failure, has been abandoned.

3. Outside of the building, and below the ground level is a third tank, of pine 10' x 5' x 5'; designed for use in storing the solution when

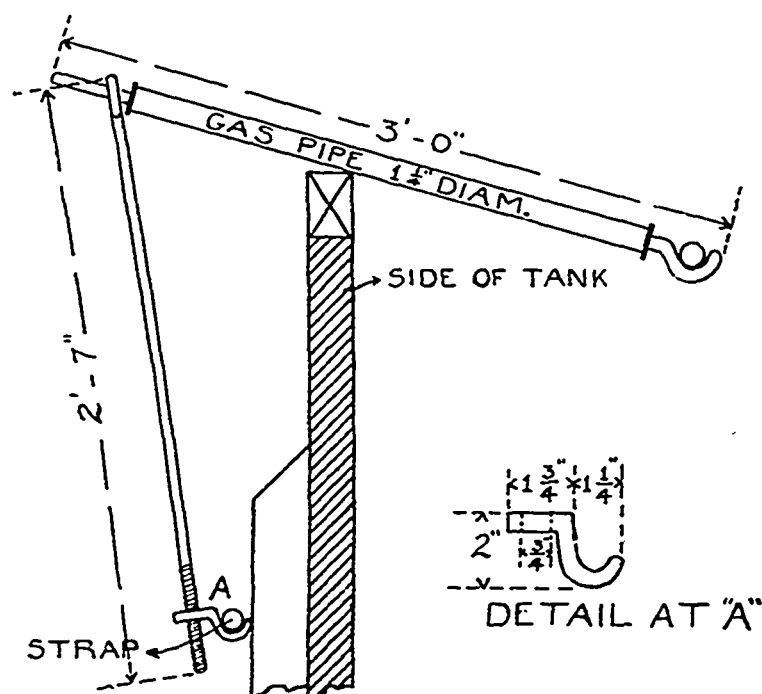

FIG. 1.

repairs to the solution tank are necessary or when the solution has become so fouled as to require filtering. This tank is lined with a simple coating of asphaltum dissolved in turpentine, and as it is not designed to carry the solution for any length of time, its factor of safety is much lower. It is so placed that the solution may be siphoned to it.

*Handling the Plates.*—Holes are punched at intervals of 2 feet along one edge of the plate, and through these long hooks are passed, which hang from a long cross-bar suspended by a differential pulley from the crane. There are three bars provided to carry the plates while in the solution. When one plate is in the bath, only two of these are used: when two plates are treated they are hung back to back upon the middle bar while anodes are suspended on either side. These bars require a support at the centre. To support the centre bar, and at the same time to be able to remove one plate from the solution for inspection without disturbing the other (a very desirable feature), the arrangement shown in Fig. 1 is used.

To support the side bars the method is as shown by Fig. 2.

*Preliminary Cleaning of the Plates.*—To secure a proper contact of the silver with the copper surface, a contact which will resist the daily scraping of the amalgamators, the plate must be absolutely clean. The slightest trace of dirt of any sort will cause a flaw in the work. The effect of the usual interfering materials is as follows:

1. "Scale" due to oxidation rolled into the surface of new flakes the silver deposits upon it in a rough, lumpy state, easily scraped off.

\*School of Mines Quarterly.

2. Thin films of oxide forming if the acid treatment is not quickly followed by a thorough washing and an immediate immersion in the solution. With this, the silver may deposit unevenly, but with so slight a tenacity that it will be washed off by the impact of the wash water applied after removal from the bath. Very similar to the latter is the effect of grease or oil of any kind.

3 *Presence of Mercury.* This, of course, is only present upon old plates. The deposition of silver upon it simply forms amalgam, which scrapes off at once. To remove the mercury three methods were tried before a satisfactory process was found:

a. Cleaning by hand with steel scrapers, followed by treatment with acid to remove the last traces of mercury. Abandoned as too expensive in supplies and labor, and because of the discomfort attending the heavy fumes.

b. "Stripping" in the tank already mentioned. The plate suspended as an anode in a solution of potassium cyanide, using iron plates as kathodes, and recovering on them any mercury, gold, silver, etc. This attempt was successful in so far as cleaning the plate was concerned, but, owing to the uneven depth of the mercury upon the copper plate, the effect was to "pit" the surface, forming small ridges

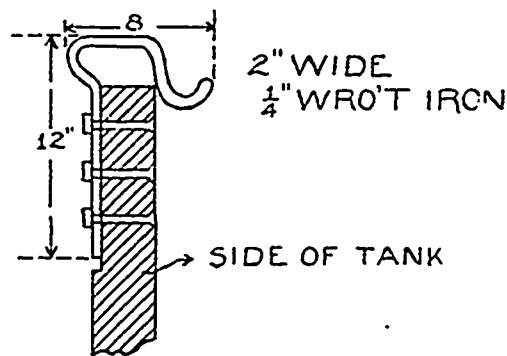

FIG. 2.

and hollows over its entire surface. Although a good deposit could be made upon these plates, they failed to amalgamate well, the heavier sands settling in the hollows and effectually preventing the contact of the gold particles with the amalgamated surface.

c. The "stripping" was followed by the use of a power scraper, which was established in one of the mills. It consists of a table, to carry the plate, so mounted upon a track that every part of the plate can be brought under the buff: a buff wheel, with emery cutting surface, and a small suction fan to collect the particles removed and to discharge them into a box of water, from which they are subsequently recovered. Two men can readily clean three plates in a ten hour shift, alternating with one another, as the labor is too severe for steady work. The plates come to the plating room in excellent condition for further treatment, and the use of acids and abrasives can be greatly diminished.

On the receipt of the plate from the mill it is set upon a rack and the reverse side painted, in order to "stop off" the deposition of silver upon that side. A solution of asphaltum in turpentine makes a thoroughly good paint, inexpensive, easily applied and quick drying. Paraffin may be used, but it is not as good in any way. Asphaltum dissolved in benzine is to be avoided, as it is softened and loosened by the plating solution. The failure of a paint is harmful in two respects: (1) by the loosened particles fouling the solution, and (2) by the waste of silver deposited on the spot left bare. Two coats of paint are applied, and twelve hours are usually allowed to elapse between the time of the second application and the immersion in the plating bath.

The paint being dry, the final treatment begins. The plate is carried to the working bench, and there treated with one or more chemicals, as its condition may demand. This bench is stoutly constructed of pine and covered with asphaltum, applied in the same way as lining

the tanks. It is sufficiently inclined to drain freely, a gutter at the lower side carrying off the washings. Several small frames of 1" material, faced with rubber strips, are so placed as to carry the plate, allowing all washings to run freely beneath it and protecting the paint. Since finishing work for a time, a hood has been built over this bench, and a small fan will be driven by a line of shafting from the motor to assure more perfect ventilation. The solutions, or "dips," are kept in earthenware jars of 12 and 20 gallon capacity. When using, these jars are placed under the drain from the bench, and the "dip" is poured from earthenware pitchers. Rubber gloves protect the operator's hands.

The various cleaning operations, as already stated, are used as the condition of the plate requires. They are (1) scouring with sand or pumice stone. Chiefly resorted to in removing scale. (2) acid dip—equal parts of nitric and sulphuric acid, with 1 to 5 p.c. of hydrochloric—to remove oxides and any mercury which may remain. The effect of the sulphuric acid seems to correct the too violent action of the nitric acid upon the copper, an action which results in the "pitting" of the smooth surface. (3) Potash or soda lye—a strong solution preferably used hot, to remove grease, etc. This solution is kept in an iron kettle, and is applied with a mop. (4) Cyanide of potassium. (5) Finally, cyanide of mercury is added, and without washing the plate is immersed in the silver bath. This tends to improve the adherence of the deposit.

*Preparation and Working of the Solution.*—The bath used is a solution of silver chloride in potassium of cyanide (the double cyanide of potash and silver), with an excess of potassium cyanide present. The action of the current is to deposit silver at the kathode while the liberated potassium cyanide replenishes the solution, by dissolving silver from the anode. The excess of potassium cyanide insures a faster and more even working. In preparing the solution, granulated silver, .999 fine, is dissolved in nitric acid, the silver deposited as chloride by the addition of salt, washed and transferred to a large filter, placed above the tank. The cyanide is dissolved directly in the tank and the solution pumped through the filter until the silver chloride is completely dissolved.

For the particular work under consideration, good results may be obtained within a considerable range of strengths of the solution. A solution carrying 2½ oz. silver and ½ lb. cyanide to the gallon gave very satisfactory results. Care must, of course, be taken to have sufficient anode surface, that the silver content may not be impoverished. From 15 to 20 anodes, each ¼" × 6" × 3/8", were used per plate. The ordinary range of temperature does not affect the work. Presence of insoluble matter becomes troublesome after a time, and a filtration every six weeks is beneficial. Amperage and distance between anode and kathode affect the rate of deposition, voltage determines the character of the deposit and must be fairly constant. With a solution of the strength described, and a distance of 16"-17", a current of 1½ volts is ample: with 2 plates 10-12" apart, 2 or 2¼ volts may be carried. The rate of deposition is .35 to .50 ozs. per sq. ft. per hour. The position of anode surface with relation to kathode surface must also be considered, as the current follows the least resistant road through the bath, and the placing of one or more anodes beyond the end of the kathode will result in a too rapid deposition on the edges of the plate, with its attendant evil, a "hard" or "burned" deposit—i.e. a deposit showing a slightly yellowish coloration instead of the dead white of proper working; rather lumpy, but thoroughly adherent. A slight excess of voltage shows a similar effect, a great excess emphasizes it largely, the deposit forming in a heavy powdery crust.

A new solution does not work as well as an old one; time is required to secure an even mixture of the various compounds. After a day's work the solution is stirred, with this object in view. Small additions of ammonia and ether seem to help to correct this tendency of a new solution, but their use is rarely necessary. It is highly desirable



to remove the plates for inspection after the current has acted for ten or fifteen minutes. Any unclean spots or any surfaces upon which the plating is imperfect are shown, and a few minutes' rescouring may remedy the evil.

When the work was nearly finished, and the plant was being prepared for a shutdown of several months, an effort was made, by use of a greatly diminished anode surface and a low voltage, to remove as much silver as possible from the solution.

*Analyses.*—To insure good work, careful watch must be kept of the solution, and silver or cyanide added from time to time, as required. The method of analysis used are briefly outlined below. They were selected after a trial of several others as being rapid and sufficiently accurate.

*For Silver.*—25 cubic centimeters of solution are taken; to this hot, concentrated solution is added at once an excess of alkaline sulphide (preferably  $K_2S$ ). Lime is added to settle the precipitate quickly; then filter, dry, remove the precipitate to a scorifier; burn the paper and add it to the scorifier with some test lead; scorify and cupel observing the usual precautions as to heat.

*For free K (CN).*—The usual  $AgNO_3$  titration method is used, with KI as an indicator. It has been the writer's practice to use a solution of 6.535 grams of  $AgNO_3$  per liter, a strength used in the cyanide process, and to employ a set of tables to calculate the value, rather than to prepare a special solution for this work. With this standard, 10 cc. of solution are taken, diluted to 200 cc. and to 10 cc. of the mixture titrated.

*Recovery of Valuable Products.*—The scrapings from the buff are cleared in a Knox pan with mercury. The resulting amalgam is squeezed, retorted and melted into small bars, which are added to the regular bullion from the mills. They make up about 7 p.c. of the total weight of bullion. About 200,000 ozs. of amalgam were recovered from 300 plates, which yielded after retorting and melting over 14,000 ozs. of base bullion, of a composition ranging from 14 p.c. gold, 14 p.c. silver and 72 p.c. copper to 5 p.c. gold, 23 p.c. silver and 72 p.c. copper. The scouring sand, etc., is settled in a box placed in the drain, and is returned to the mill. It is not in a proper condition for this treatment, however, and it would be better to sell to a smelter. A small additional amount was recovered from this source. Old and worn anodes are remelted, cast into bars and hammered into shape for a second use.

The cost of the operation, including labor and supplies, need not greatly exceed the cost of the silver. The work of refitting all the mill with new plates occupied about six months, during much of which time four plates were plated daily with two ozs. of silver to the square foot. It was considered advisable to have a plant larger than the actual needs of the company, as the time during which the plant lies idle is more than made up for by the increased recovery of the mills when the plates are in good condition. Moreover, when the cost of the building is included, the additional expense incurred by doubling the capacity should not be over 20 p.c. It would not be wise to limit the width of the tank too closely; slight irregularities in the solution might demand greater distance between anode and cathode to insure good work.

SULTANA MINE OF CANADA, LIMITED—Mr. W. M. Strong writing under date of 20th inst. reports: Our No. 1 shaft has reached a depth of 490 feet and we are now sinking to reach No. 3 level. No. 7 level at a depth of 461 ft. has been driven north 110 ft., the last 90 feet of which is in ore of satisfactory value. We expect to resume crushing at an early date under conditions favorable for continuous and profitable operations.

## What Has Become of the Gold Run in the Tailings?

By MR. B. C. WILSON, Waverly, N.S.

It has long been a popular belief that in general milling practice in Nova Scotia nearly as much gold has been lost as obtained.

I should explain that this refers more particularly to the earlier days of gold mining in the province, say from 15 to 30 years ago, when it was often asserted that we rarely saved 75 per cent. of the gold in the ore and more frequently not above 50 per cent.

Without fully endorsing so sweeping an assertion, I consider it just possible that the assertion was so near the truth as to leave no room for an action for libel.

It is a well accepted fact that assays of tailings made years ago showed a variable loss the Province over of from \$3.00 to \$9.00 per ton of ore treated, which may be the more readily believed when we bear in mind that in the earlier days none but comparatively rich ore was treated, and but little care exercised.

The writer can readily call to mind the time when an ore that would not yield an ounce per ton was not considered valuable, and though later this standard of remunerative value was reduced to half an ounce, which in either case left a margin for loss which would not be now tolerated, in fact could not be, in the low-grade ores of 2 to 5 dwts. per ton, which in large quantities are now the favorite investments.

From the tailings of recent years it is considered indifferent treatment in any well regulated mill if the loss reaches more than a few cents per ton, and hence we do not hear of parties anxious to treat the sands now being delivered from our mills; it is always the old sands deposited a quarter of a century ago that they want to operate on. Whether it is the distance of the past is lending enchantment to the view I am not prepared to say, but every year witnesses a new crop of parties desirous of investing in these old deposits, but so far it has proved a veritable *ignis fatuus*—just in view, but never tangible.

In short, neither assay nor practice has been able of late years to locate the gold supposed to have existed in these old sands, and yet I think the evidence is almost conclusive that the gold was there in remunerative quantities, and the pertinent question is, "What has become of it? and where is it now?" and its solution is interesting from an inquisitorial as well as of economic value—for I believe that money invested in the attempt to recover the gold known or supposed to exist in these old sands is just so much capital and energy wasted, to a very large extent; and again the question, "Where has it gone?"

The theory frequently advanced that the greater specific gravity of the precious metal, causing it to persistently seek a lower level, is not sustained by facts, for examination has proved that the very bottom of the deposits is no richer than the top—in fact, in some instances, not as rich.

Some years since the idea was advanced that certain organic acids which are known to permeate our surface waters to some extent, were in some unknown way instrumental in slowly dissolving the fine particles of gold in the sands, and it is possible that the loss of some infinitesimal quantity may be thus accounted for, but not sufficient, I believe, to be really appreciable.

It is not many years since that the cyanide process was introduced as a means of extracting the fine particles from refractory or other ores, and the process has met with a very large measure of success and is now in very general use, and I remember, when it was first introduced in Nova Scotia, we were assured that a three per cent. solution was about the proper consistency for efficient results, while later two per cent. was considered ample, and so on with a gradually descending percentage, until now we have it on the authority of those who should

\* Paper read before the December meeting of the Mining Society of Nova Scotia.

know that even less than the one-fourth of one per cent. is all that is required:—how much less, I suppose, is left to science and experiment to determine.

Incidentally referring to this, allow me to call your attention to the very general, I may say excessive, use of cyanide in the mills in Nova Scotia some years ago.

Twenty five years ago it was the universal practice to keep a supply of the commercial article in stock and a vessel of a highly saturated solution ready at hand, and every time the mill was stopped from any cause, to dash a lot of it across the plates "to keep the green off" as it was expressed: otherwise to remove the oxidation of the copper showing through the mercury coating; and I can call to mind mills where it was customary to take a brush and every hour or so give the plates a touching with the concentrated solution by the way of "keeping the plates in order," and can further call to mind another mill where it was the practice at the weekly clean-up to use half a pound or more cyanide to "brighten up the amalgam and make it coalesce more readily."

I will concede that there might not have been the same extravagant use of the solvent in all the mills of the period but it is safe to say that its use in every mill was largely in excess of legitimate requirements.

As greater intelligence and more careful practice was brought to bear on the industry the use of cyanide for the purposes named was proportionally reduced and latterly, since the solvent properties of the chemical have become more generally known, it is rarely used in excess.

Reviewing the foregoing I may now ask if here is not an answer to "what has become of the gold in the tailings," more particularly when considering that an unknown quantity below the one quarter of one per cent. will give sufficiently rapid action for industrial purposes—and further that there was an accumulating quantity administered every hour or day, or even if only once a week continuously or intermittently, it was sufficient in a year or few years to pretty thoroughly remove all the gold in the sufficiently finely divided ore particles until it is not so much the wonder that sands of twenty-five years standing and presumed, or by tests shown, to carry from \$2.00 to \$6.00 per ton now show only a dollar or fifty cents a ton. The wonder is that they show any at all: and further to suggest to sanguine individuals with a penchant for working over old tailings to "stop and think before they further go" and consider if it is not wise to ascertain if Nature in her extensive laboratory has not anticipated them?

In presenting this view I do not offer it as a positive and satisfactory answer to the question, but as one eminently probable, and whether the idea of important values in the sands of ores treated a quarter of a century ago is not very chimerical.

Referring to the ores now being treated in Nova Scotia, I consider it a matter for congratulation that through the greater attention given to amalgamation and concentration the loss of gold is rapidly getting down to the minimum and in a few years we will cease to have any reference to the gold in the sands and as to cyanide or other solvents, that we will hear of them only through their legitimate action in the properly constructed plants of our modern reduction works.

CANADIAN MINING INSTITUTE.—The Annual General meetings of this representative body will be held in the Windsor Hotel, Montreal, on the 8th, 8th and 9th March next. A single fare rate has been granted by all the railways to mining men attending these meetings.

So far, we understand, close upon thirty papers have been intimated for discussion. All mining men are cordially invited to be present and take part in these meetings.

## Mine Accounts.

By A. J. YUNGBLUTH.\*

It is my purpose in presenting this paper to deal more generally with the arrangement of mine accounts for the cost sheet than with the method of keeping them in detail. It may not be out of place to say, however, that the success of the proper arrangement depends upon the method employed in keeping the accounts. It is necessary, in order to get close figures of cost at the end of each month, that the method of handling the supplies should be on the basis of cost, freight and drayage added, and supplies issued only upon requisitions from persons authorized. This insures the proper charging of the material, besides being a check on the supply clerk in issuing supplies, so that his account will be credited with everything issued or sold, while at the same time the person who signs for the material will see that he receives the proper weight or count. It thus does away with the old method, where the profit on the supplies would cover up any loss there might be by reason of carelessness in the supply house, in not charging properly all supplies issued. Having this department well under control insures accuracy in the figures of cost for supplies as presented each month, knowing that there will be no material change at the end of the year by profit or loss in the supply account.

The distribution of labor is, of course, very important, and great care must be taken in keeping the time in a manner that will insure the various accounts being charged for the time actually worked in each department. This is most readily done by opening a page in the time book for each different job, and recording the time worked by each man on that particular work. It may be that several jobs will be charged to the one account when the distribution sheet is made up for the journal, but it will permit getting the cost accounts with more detail should it be desirable to do so.

In addition to the charges for labor and supplies, we have the fixed charges. Taxes being the principal item, it is necessary that we should charge a proportion each month. It being usually a large item, the effect on the cost sheet would be too great were it charged in total on the annual sheet. The proper way to handle this account is to charge off the taxes of the current year, and not those of the past year, as has been done at some of the mines. This should be done by journal entry and appear on the trial balance as an account payable. Insurance should be handled in the same manner. While the effect is not so great, it is nevertheless, very desirable, for close figures, to charge the expense on the basis of monthly proportions. In fact, this rule should apply as much as possible on all items of fixed charges.

This is equally true in the depreciation accounts. While it may be desirable to carry an item of construction through several years, it is more satisfactory to charge off a stipulated amount each month. It gives a more uniform cost sheet, and we do not have to anticipate these charges when making estimates of cost during the year.

We must not overlook the most important item in connection with the cost sheet, viz., the product. It was the custom sometime ago to figure the output so as to insure a very generous overrun when the stock piles were cleaned up. I am not sure but what this custom still prevails at some of the mines, the idea being that the excess would pay for the loading, and offset the expense of taxes or some other item not shown on the monthly cost sheet.

I appreciate the feeling of satisfaction to the operating department, when after the stock piles are cleaned up they find a large overrun, which, when added to the product for the month, gives them a cost per ton of 20 to 25 per cent below the cost for the previous month, which was not effected by any such condition. (When there is any excess from the stock piles it should be added to the product for the

\*Lake Superior Mining Institute.

year, and not for any one month. In this way we maintain more uniform conditions in the monthly cost sheet.) If we consider the result under the conditions just mentioned, of what value are our cost sheets for the information and guidance of the operating department? Should the cost of any one month be above the average the operating department find solace in the thought that to figure in the overrun on the product and the profit in the supply accounts "will bring down the cost about right."

It is clearly apparent that this system is far from satisfactory to the progressive manager, who realizes that in the days of sharp competition and very low prices he must know at the end of each month just what the ore is costing to enable him to make sales at a figure which will insure him some return on his investment when the annual balance sheet is drawn off. This can only be done by figuring the product as near as possible to the actual weight per skip, and the supplies at the actual cost as well as the other charges mentioned, and in this way the cost sheet for each month gives him reliable figures upon which he can base the price for the ore on board cars at the mine.

We have now taken up the method of handling the items that enter into the cost sheet, and will review the arrangement of the accounts.

The first consideration in the list and arrangement of accounts for the cost sheet must be with the view of separating the items of cost and grouping them in such a manner that the expenditure will be clearly shown and the increase and decrease readily noted. In comparing the cost sheet with the previous month it is not sufficient to compare the cost per ton alone, but the cost in dollars and cents is the most important. As in the first case, an increased output may show a decreased cost per ton, while in reality the cost may be higher in some departments than for the previous month, and were the comparison not made in dollars and cents the fact may pass unnoticed and the cause of the increased cost not be investigated. To enable a close comparison of the cost for each account, it is necessary to distinguish between the operating and repair expense of the account, and in this way the increase and decrease of cost are very readily located.

A very convenient arrangement of accounts is to group them under the following headings :

1. General expense { Insurance, taxes, engineering.  
Analysis and office expenses.
2. Maintenance { General surface expense, repairs to buildings, machinery, trestles, cars, etc.
3. Mining expense { The general items of mining cost, breaking ore, sinking, drifting, timbering, etc., to represent the cost of underground work, hoisting and pumping being also included.

A total of the three general accounts, as above, shows the producing cost, including, however, only the regular cost accounts. The extraordinary expenditures are shown below this total line and include Exploratory and Depreciation accounts as follows :

1. Exploratory { Exploring in mine—Diamond drilling.  
Exploring outside—Test-pitting and diamond drilling.
- Depreciation { Inventory,  
Improvement.  
New construction.

By drawing a total to this point, which includes the five general accounts, we find the cost of the ore on the stockpile, when stocking, or in the pockets, when loading direct into cars. To this total must then be charged the cost of loading and shipping on the basis of the tonnage loaded by steam shovel, by hand, or at the pocket, together with any other expense in connection with shipping, including stockpile bosses and ore sorters. In arranging the accounts of loading and shipping in this manner, we find the cost per ton on board cars will represent the actual cost by the different methods of loading ; thus if we

load 1-3 of the output from the pocket, 1-3 by steam shovel, and 1-3 by hand, we get the exact cost for each on board cars at the mine.

The arrangement of the detail cost accounts under the respective headings, as before mentioned, is a matter of the greatest importance and should be classified so that the cost of the various operations in the process of mining are clearly defined, and by which any changes in the method of working would be apparent and the effect shown either as an increase or decrease in the cost of that particular operation. After we ascertain the cost of the ore on board cars at the mine we should add to this figure an arbitrary charge for selling expenses and insurance, and thus go one step further in the cost of mining and marketing our product.

To present the figures in this manner requires that the line be closely drawn between maintenance and operating expenses, in order to show whether the changes in cost are due to repairs or operating, and to bring clearly before the manager this fact, which might suggest to him some modification in the system of working or in the plant. If a separate account were not kept and the repairs and operating charged in one account the fact would not be as apparent, unless an itemized statement was made, which is not as satisfactory as having the account on the general books where you can get the figures not only for one month or one year, but for several years, without having to go back and pick them out from the general charges.

To my mind the system of detail, on about the lines here given, is of the greatest assistance to the mine manager, as it brings before him the figures of cost in a manner that would aid him to locate readily the increase or decrease in cost of one month with another, or one mine with another, and to show the effect of any changes he may have made in the plant, the method of working, or the class of material used.

In addition to the cost sheet there are other statements which render the manager material assistance. It must be borne in mind that the manager of today, working against the sharp competition in the iron market, fully appreciates the assistance rendered him by the accounting department in preparing reports of cost of operating his mine—the product per man, the wages of contractors, the consumption of material, the cost of construction work and various other items about the mine. While he is thoroughly familiar with the expenditure and the results obtained, nevertheless, to present them on monthly and annual reports will be found of the utmost importance and convenience in keeping the figures before him for future reference. It will not be necessary, where a system of accounts as here mentioned is used, to wait until the thirteenth statement is made up in order to get the exact figures of cost for the year.

I might add that the principle that governs the successful manufacturing establishment, of not only keeping the cost of each article made, but the cost of each operation on the individual piece that enters into the construction of the finished article, should govern as far as possible in the system of mine accounts.

Before concluding let me say that I think it would be found most desirable and prove an advantage to all interested if a uniform system of mine accounts could be established, also a uniform cost sheet and wages statement. The latter could be exchanged between the different companies, should it be thought advisable to do so, as a matter of general information.

It may be thought by some an unjudicious thing to establish a new basis throughout, and in that way lose the benefit of comparisons with their previous cost sheets. However, I think the subject important enough to bring before this meeting and believe that if the idea was carefully considered it would certainly meet with favor from some of the larger companies, especially those operating several mines, and am sure that if their system was once placed on a basis about as outlined in this paper the result would prove most satisfactory. I should be pleased to hear read at our next annual meeting a paper on this subject from some one connected with the office of a mining company where a different system is in force. I think in this way we could gather considerable information on the subject of mine accounts.

To show more clearly the arrangement of the detail accounts before referred to I give herewith a copy of the monthly cost sheet of one of the iron mining companies operating in the Lake Superior District.



SUMMARY OF COST PER TON.

	Current Month.			.....Months, 190..			.....Months, 190..		
	Loaded by hand.	Loaded by stm.shovel	Loaded at pocket.	Loaded by hand.	Loaded by stm.shovel	Loaded at pocket.	Loaded by hand.	Loaded by stm.shovel	Loaded at pocket.
Cost on stockpile, as above .....									
Cost to load, as above .....									
Cost on cars .....									
Commission and expense, home office .....									
Total cost on cars .....									

<i>Accounts not sunk off.</i>	Current month.		.... Mos. 189..		.... Mos. 189..		Comparative Cost.			X Cost of production Labor .....	.... Mos. 190..	.... Mos. 190..
	Amount.	Per ton.	Amount.	Per ton.	Amount.	Per ton.	190....	Mos.	Tons.			
New Construction .....							190....	Mos.	Tons.			
Improvement .....							190....	Mos.	Tons.			
							190....	Mos.	Tons.			
	Feet	Cost	Per ft.	Feet	Cost	Per ft.	Feet	Cost	Per ft.	+ Total cost .....		
Sinking .....										Labor .....		
Drifting .....										Supplies .....		
										Total .....		

Mr. Kelly—I would like to ask the author of the paper what disposition he makes of the item of fuel? He did not mention fuel in his enumeration of items, and I would like to ask if that is divided between pumping, hoisting, exploring and similar heads?

Mr. Yungbluth—Fuel is included in the general item of supplies and is charged to an account of “Boiler House Expense,” and is, with the other items of supplies used in the boiler room, charged off to the accounts using steam on the basis of the power used by each. This would be for hoisting, pumping, compressors, exploring, etc.

The President—Mr. Yungbluth, do you also keep a separate statement of supplies and the cost per ton of supplies?

Mr. Yungbluth—Yes, in addition to showing the cost of the various accounts on the cost sheet—such, for instance, as maintenance, operating and general expenses—we also make a statement showing the amount and the cost per ton for the various supplies used. Our supply account is divided under ten headings: General supplies, iron and steel, oil, grease and candles, machinery, explosives, mine timber, building material and fuel, barn and sundries.

The President—Mr. Kelly perhaps thought you referred to that.

Mr. Kelly—Yes, that is right. As I understand it, there are two cost statements, the special one showing the cost of each item of supplies per ton and the general cost sheet showing the distribution of the total value of supplies used under such general heads as maintenance, operating, etc. The same inquiry might be made as to blacksmith labor, carpenter labor and some other labor items which may be divided into maintenance, operating, etc.

I am trying to draw out that it is often as important to know what was the total explosives used, the total fuel used, or the total blacksmith labor used, as it is to know the cost of the items distributed between and embraced under such heads as maintenance, operating, constructing, etc.

Mr. Yungbluth—The labor of the shops that enters into the mining cost is added to the other labor, and on the cost sheet is charged out under that head. The supplies used in operating the shops are charged with the other supplies under that heading. We distinguish

only these two headings on our cost sheet. The supplementary statement of “Supplies Used,” while showing the amount of the various classes and the per ton cost of each, does not take in the items of shop expense. One of the reasons why we do not consider this, is that the shops do more or less work for stock, which is charged to the stock accounts. It is also the case at some mines that they do work for other mines of the same company, and sometimes for outside parties. So the shop expense is not altogether a cost account in the same light that explosives and fuel are.

A Member—I would like to ask Mr. Yungbluth whether the the books show the volume of business of each shop.

Mr. Yungbluth—No. We carry no account on our general books with the shops. It is closed off before it gets on the journal. The expense of the boiler house is distributed in the same manner.

A Member—Is there nothing on the books to show the expense of the different boiler houses?

Mr. Yungbluth—The boiler-house expense is closed off to the amounts using steam on a fixed basis.

Mr. Fitch—I would like to ask Mr. Yungbluth whether his cost sheet from month to month carries the totals of the previous months for the same fiscal year. That is, whether the second month in the year he carries his main totals showing the cost of the previous two months; and when he comes to the third month, for the previous three months. Also whether he has anything on the cost sheet showing the cost of producing in each stope; and if so, whether he carries the cost from month to month, showing the average cost of the whole on that particular stope from its commencement. That, of course, would not apply so much to soft ores as it would to hard ore mines, where the stopes vary largely in cost of production, because in one chamber the width and height of the stope and the method of stoping would be different from that in another chamber. We find in our practice and under different methods of stoping, that it is not fair to take one month alone and make the comparison, because the work in the opening process of a stope is much more expensive than when it is fairly opened out and is going on uniformly; therefore we have found it

very convenient to carry the cost from its commencement. And we have carried it on for one fiscal year, and from one year to the other, so that the average in that particular stope might be carried along for three years before that level would be worked out and exhausted.

Mr. Yungbluth—We carry the cost for the current month and the total cost for all of the months for the fiscal year, and also show the total cost for the same number of months of the previous year. We do not show on the cost sheet the cost of each particular stope. The number of stopes we have, in the first place, would make the sheet very large. We do, however, make a statement showing the stope number, its location, level, the product of that stope for the month, the amount of supplies used in that stope, the number of days worked by contractors and the contractors' rate per day. In soft ore mines the stope which you have this month might be worked out next month. The progress made is so much faster than in a hard ore mine. We have taken some of our mines and shown the mining cost per ton from several districts, by subdividing the mine into several districts, and showing the mining cost for each district, but the resulting statement is supplementary to the regular cost sheet.

Mr. Fitch—Of course I can see that that would not apply in soft ore mines. However, a level might be carried as above suggested, and charged with the several kinds of work going on at that level and credited with all the ore, and show the relative cost in comparison with every other level.

Mr. Yungbluth—The sheet that we have shows each contract for the month, and it also shows the details of the contract for the previous month. It is on the lines of a comparative contract statement.

The President—This is a valuable subject for us to discuss. Are there any further enquiries or remarks?

Mr. Thompson—The question comes up how far it pays to go in subdividing accounts. I take it, the value of these accounts is to get cheaper ore, to get more ore for less money. There comes a point somewhere, where the saving to be effected by the keeping of these accounts in great detail is offset by the cost and labor of keeping track of such details. The question constantly arises just how far it is desirable to chase for details.

There is one style of account which has not been mentioned here which I know is kept by some of the mines. I mean a sheet by which the management keeps account from day to day of what has been done, making a detailed statement of the number of men and the number of tons produced and the number of shift-bosses, the number of timber men, the number of trammers and miners that have been employed for the ore produced, and a record for each working place, with the number of days' labor to that working place, whether the work is drifting or stoping or whatever it may be. This is not exactly a cost sheet, but gives a comparison of each day with the day before, and affords a very convenient basis for estimating costs. I know such a sheet is used with profit in a number of mines.

Mr. Yungbluth—I might say in regard to Mr. Thompson's remarks about the amount of money to be expended in producing the the detailed figures of a cost sheet, that in a sheet such as we employ there will not be any more expense attached to it nor will there be required any more labor than with some other cost sheet. It will not cost any more to make it up in one way than in another. The idea is to have a uniform sheet, so that we shall all be working on the same lines.

Mr. Kelly—In line with the suggestion of Mr. Thompson, for a daily cost statement, permit me to advocate a change in the common method of speaking about the amount of ore produced with reference to labor. It is generally spoken of as tons per man, but I contend

that it is better to reverse the order and figure the labor per ton, or days' work per ton.

Thus, instead of saying "two tons per man," we would say, ".5 of a day's work per man;" instead of "2½ tons per man," ".4 of a day per man."

The principal advantage of this plan is that the labor can be subdivided. This can be shown more clearly by assuming an example which may be tabulated as follows:

Kind of men.	Number of men.	Output in tons.	Days per ton
Miners.....	110	628	.175
Trammers.....	32	628	.051
Laborers.....	47	628	.075
Bosses.....	9	628	.014
Surface.....	62	628	.099
Total.....	260	628	.414
Stockpile.....	13	628	.021
Total.....	273	628	.435

In this case a ton of ore is produced by .175 days' work of a miner, .051 day's work of a trammer, etc., and the sum of these figures gives the total days' work per ton. If the other way is employed, in speaking of the different kinds of labor, we would have to say that the miners produced 5.7 tons per man, the trammers 19.6 tons per man, etc., the relative proportion of the different kinds of work being shown inversely and not in comparable form. The labor per ton plan permits of any subdivisions desired, into different classes of labor, different shifts and different parts of the mine.

It has a further advantage in the case by which the figures can be converted into cost by simply multiplying them by the average rates of wages.

We adopted this system in our daily reports two years ago for the purpose of showing more readily the ratio of output to labor, without stockpile force for comparison throughout the year; and with the labor of loading added to give complete figures. I can commend the system for its simplicity and flexibility.

Mr. Brown—I would like to ask Mr. Yungbluth what disposition he would make of such items of expense as sinking a new shaft, sink-additional levels in old shafts, or driving main drifts on new levels.

While work of this character may, and usually does, have some value for future mining operations, still it could hardly be considered as an asset for inventory purposes. Our plan has always been to charge on our monthly cost report any expenditure incurred during a particular month for these purposes.

In fact, we endeavor to show on our monthly cost report all expenditures made during that month, so that at the end of the year our cost report shows the total amount expended at the mines for labor and material. We then charge off each year all new equipment purchased as well as such other items as I have mentioned.

In order, however, that extraordinary expenditures of this nature may be intelligible to persons unfamiliar with mining details, we have departments on our cost reports outside of the ordinary mining account. For instance, the items of sinking and drifting, which I have mentioned, would be charged under the head of "Opening." We endeavor to condense our cost report entries as much as possible and still convey such information as will show the expenditures intelligibly to those for whom the report is designed. For the local management such information as will show particular items of cost is always at hand outside of the cost report.

The items I have mentioned are very often of large amount, and I am not sure of the disposition Mr. Yungbluth would make of these items on his cost report.



Mr. Yungbluth—We are about in line with Mr. Brown as to the account of opening; but instead of showing it under the heading of opening, we show it as sinking and drifting on the cost sheet. The item of equipping a new shaft and furnishing the machinery plant we carry under the head of construction, and open a separate account in the ledger, and can have as many sub-accounts under that head as may be desired. For instance, there might be one account with the shaft, one with the engine house, another with the hoisting plant, and a separate account with the foundation of the hoisting plant, the cost of erecting, the cost of the plant itself, etc., through as many accounts as thought desirable. The account can be closed off each month or can be carried on until the end of the year. A good plan, I think, for a monthly cost sheet is to make an estimate of the cost of the work as nearly as possible, and then determine about what length of time the account is to run before it is all closed off; and then as soon as the work commences, charge off an equal portion each month.

Mr. Pope—I take it from what Mr. Yungbluth says that the ledger balances at the end of his fiscal year would represent the same result that the inventory would show. The ledger should show the amount on hand. To what account would he charge or credit the deficit or surplus? In charging construction account for mine expenses what would he do with the various supplies which the mines get when a certain work is discontinued? Will they be passed out again by the supply clerk, or will the supply accounts be charged with a certain amount of credit? The supply account should always show the exact value of the supplies on hand, and everything used must be charged at once.

Mr. Yungbluth—Of course there is apt to be a little difference at the end of the year. In handling the supply account, as I state in my paper, the difference is very slight; its effect upon the cost per ton for the year, whether it be a credit or a debit, is quiet immaterial, and is handled as appreciation or depreciation of inventory on the cost sheet. When the operation of a plant has been discontinued, the supply account is charged with the material, machinery, and any part of the plant which has been taken away and which is not in use, and the account which was originally charged with these things is credited.

Mr. Brown—I do not think Mr. Yungbluth understood my question as to the charge which he would make of opening work; and I would like to put it in a very short form for a reply. What charge would you make monthly for money expended for opening, such as shaft sinking and permanent drift work during the year? Would you charge that along on your cost report monthly, or at the end of the year?

Mr. Yungbluth—The expenditures for permanent sinking and drifting would be charged off monthly. That is in the line of regular development work.

The President—What would you do, Mr. Yungbluth, when you sink and keep on sinking a permanent shaft? And in case you drift along a level and do not intend to use that for some time?

Mr. Yungbluth—In the matter of a shaft, if we were going to sink for a new level, we would simply charge that to the sinking account; and in case of a drift, to the drifting account.

The President—Charge it right off as soon as you spend the money?

Mr. Yungbluth—Yes.

Mr. Olcott—It seems to me that while it might be desirable, for the purpose of comparison, to have all these statements exactly alike, it would be almost impossible to obtain them. In the first place, very few superintendents compare costs. As a rule, the companies would not care to have the management go around comparing costs, and in the next place, it would be impossible to make the same accounts for

each mine, because there are hardly two mines alike; not only that, but they have different ways of mining on the same range and also on different ranges. For that reason it seems to me almost impossible to get two or three mines to make up a cost sheet on exactly the same basis. One point has been entirely overlooked in our discussion, and that is, where do all these data come from for these statements? You may have a man in your office who will give you every detail that has come to his knowledge, but of what value is it unless the original data turned into the office are absolutely correct? Some mines have foremen or time-keepers, men who get from \$45 to \$50 a month, and they go through the mine and take the time each day, and I dare say there is not one out of a hundred who will give the same care to distributing this time as the accountant will in the office; and if these data which go into the office are not absolutely correct, the information conveyed by the cost sheet is not correct. It is the same way in the distribution of supplies, although they are kept more carefully.

It is impossible to have these supplies go out at cost and not have a deficiency at the end of the year. I appreciate fully the value of these cost statements, but my idea is that they should be kept as simple as possible, and that the information that comes from the time-keeper be absolutely correct. Of course it is valuable to have all the side statements to show the cost, but I think even in that it is sometimes overdone. I recall an incident of some work that was being done years ago at the Chapin Mine. One of my duties was to keep account of the power drills. This was kept in a book that had about fifteen headings and was supposed to show exactly what each drill did, how many feet drilled and how much it cost, the daily reports being made out by the miners. After keeping that book for twelve months, I balanced up and compared with the year before, and there was a great discrepancy; so I investigated and found that those fellows simply guessed at what they had drilled. There was not one in fifty who had a watch. I think, for that reason if you are going to have any accounts or cost sheets you should have them just as simple as possible but the data should be accurate.

#### The Use and Abuse of Colliery Locomotives.\*

By W. W. CLAYTON, M. Inst. M.E., M. Inst. C.E., and M. Mech. E.

As it was a colliery owner who first used a locomotive engine as a commercial success, a brief account of its early history may be interesting to the members.

In the year 1811, John Blenkinsop, who was then the proprietor of the Middleton colliery near Leeds, ordered from Matthew Murray, an engineer in Leeds, a locomotive for use on his colliery-railway. This engine started work in August, 1812, its weight was between 4 and 5 tons, and it was propelled by means of a toothed wheel working in a rack at one side of the rails. It regularly hauled 30 coal-waggons, weighing altogether about 94 tons, at a speed of 3½ miles an hour.

Trevithick, a Cornish engineer, was at the same time experimenting with the locomotive, and built one for Blissett, of Wylam; for some reason or other this engine never worked on the railway, but was used for another purpose at the colliery. William Hedley, the viewer, however, was not content to let the matter rest: he set to work to improve upon the engine, and after making exhaustive experiments as to whether the ordinary adhesion of the wheels of an engine working upon smooth rails would be sufficient to ensure the useful application of the whole of the steam force, he built an engine to work on his plan. It had a cast-iron boiler and one steam-cylinder 6 inches in diameter. This engine, though much superior to Trevithick's, was still very unsat-

\*Paper read before the Chesterfield and Midland Counties Society of Engineers.

isfactory; he therefore built another one, with a larger boiler of wrought-iron and two steam-cylinders. This was the first locomotive to work successfully by its own adhesion on smooth rails. It was called the "Puffing Billy," and is now in the South Kensington Museum.

George Stephenson, who had watched Hedley's experiments from the first, recommended the proprietors of Killingworth collieries, where he was employed as enginewright, to adopt locomotive power. An engine was built in the colliery-workshops which was practically a failure; but Stephenson was not to be beaten, and a second engine was built at Killingworth in which many of the most serious defects were remedied. It continued working on the colliery-line for many years, and its success decided the directors of the Stockton and Darlington Railway in 1822 to adopt steam-locomotives for their line.

Such, briefly, is the history of the locomotive to its first use on a public railway, and though the celebrated trials at Rainhill did not take place until (some years afterwards) October 1st, 1829, its success was now fully assured.

Locomotives used at collieries, leaving out of the question large tender engines, sometimes employed, are tank-engines having inside or outside cylinders, and are carried on four or six coupled wheels. The tanks are variously placed. The most common and certainly the best form is the saddle-tank placed over the boiler-barrel and sometimes extending over both smoke box and fire-box. Side or wing-tanks are placed on each side of the footplate, partly with the idea of improving the appearance, which they undoubtedly do, and partly to lower the centre of gravity of the engine, but as the water is carried farther away from the centre of the engine, this is only done to a small extent. In small engines, side-tanks are a great disadvantage, as they interfere with the access to the motion-bars inside the frames. Under-tanks, placed under the boiler-barrel and between the frames, are the most objectionable of all, as they block up entirely the access to the front of the fire-box shell for washing out purposes.

Whether inside or outside cylinders are best is a question that has been much debated, but there is no doubt at all that outside cylinder engines are simpler and cheaper to build, and are therefore more suitable for rough usage than inside cylinder-engines. In America, Russia and many other countries, engines with inside cylinders are entirely unknown. It is quite possible to build outside cylinders in such a manner that there is no possibility of their becoming loose.

The choice between engines on four or six wheels depends entirely on the curves upon the railway and the speed intended to be run. The slower the speed the sharper may be the curves which the engine will traverse in safety. About collieries, curves should always be laid wide to gauge, giving say  $\frac{1}{4}$  inch in 150 feet curves to as much as 1 inch in 40 feet curves. Six coupled engines, with a 12 feet wheel-base, will readily pass round 150 feet curves laid in this manner, especially if the flanges of the driving wheels are thinned. This thinning of the flange of the central wheels adds very considerably to the life of the crank-axes, as it reduces very considerably the nip of the rails, the most destructive force against which they have to contend.

As a general rule, four-wheeled engines may be used up to 22 tons in weight, heavier than this (unless the roads are good) they are very destructive, and especially so if made with short wheel-bases, say under 6 feet. There is no difficulty with engines of 7 feet wheel base working round curves of 40 feet, but over 20 tons in weight engines with six wheels are much to be preferred, and their economical working on rough roads may be greatly assisted if they be properly placed on suitable springs.

The spring-gear should be so designed that when the engine is standing on an uneven road the distribution of the weight on the wheels should not be materially altered. There are various ways of accomplishing this object. One is by placing equalizing levers on each side of the engine between the ends of the springs. Another way is by

placing a large cross-spring pivotted in the centre at the trailing-end of the engine. The latter arrangement has the additional advantage of leaving the driver's foot-plate clear of springs.

The proper proportions of springs is an important factor not only in the economy of the engine and rails, but also adds greatly to the comfort of working. They are often too short, too narrow, too deep, or have too much camber, and when all these faults meet together a lump of cast-iron would answer equally well. In a wide spring, the hole through the centre, which is the ordinary method of manufacture, is a much smaller proportion of the total section than in a narrow one. It is, however, not always possible in designing locomotives to get in exactly the spring that one would wish.

Some engineers have the impression that the greater is the number of brake-blocks the greater is the efficiency of the brake. Such, however, is not the case, as friction is proportionate to weight and not to surface, therefore two blocks acting on two wheels are as efficient as six blocks on six wheels. Brake-blocks wear the tires very considerably and for this reason it is desirable to have a block on each wheel to ensure equal wear of the tires. Cast-iron blocks, covering the flange as well as the tread of the tires, are the best to use. As the size and weight of trucks have increased greatly, requiring the use of larger engines, steam-brakes are now almost a necessity to relieve the drivers of the hard labor that constant breaking entails. Reducing valves should always be used in connection with steam-brakes, so as to properly control their action.

The most important part of a locomotive is the boiler, which is now usually made of mild steel plates; but whether this material is the best for the purpose is not a settled point. With bad water best Yorkshire plates last better.

Boilers should be so fixed and carried that none of the strains to which the frames are subjected should be transmitted to them. They should be firmly bolted, both tube-plate and smoke-box, to the cylinder, so that no movement can possibly take place, ensuring a rigid connection for the steam-pipes.

At the fire-box end, proper division should be made for expansion, which is best obtained by means of a clasp over the angle-brackets at the sides of the fire-box shell.

It is of the greatest importance to watch carefully that the provision for expansion does not become inoperative, as when this occurs enormous strains come on to the boilers, causing trouble with the vertical seams, leaky tube-plate angles, and often cracking the corners of the fire-box shell-plate.

The practice of cramming boilers with a large number of small tubes is a very objectionable one, being often done to make an imposing show of large heating-surface, but as the relative value of tube heating-surface is only one-tenth that of the fire-box, leaving out a few tubes is never felt, and the extra space gained between each tube is a great advantage, and extra strength is left in the copper tube-plate.

What is the best material for tubes is a question which can only be decided by the conditions of working at each particular place. Brass tubes will not answer at all with gas-coke or coal containing a large amount of sulphur. The tubes will thin very rapidly immediately in front of the ferrule at the fire-box end and collapse in a few months. Steel or iron tubes answer very well for such fuel, and provided the water contained no free acid, would be the best to use. When both fuel and water are bad, copper tubes are the only ones that will stand. Care should always be taken that the tubes project through the tube-plates, as these depend entirely on the tubes for their support, and when these are allowed to get within the plates, bulging inevitably takes place. Iron and steel tubes are often put in with a copper end, on account of the idea that they cannot be made tight in the fire-box tube-plate without this. There is no difficulty in making a steel tube tight in a copper plate, if care be taken to have the tube thoroughly clean



and bright so that there is perfect metallic contact between the tube and the plate.

The boiler is undoubtedly that part of the locomotive which comes in for the greatest share of abuse, mostly from the use of unsuitable water.

Absolutely pure water is very bad for boilers, as no protective scale is formed on the surface of the plates, consequently corrosion takes place very rapidly, and is indicated by the presence of rust in the water-gauge glass.

Water containing magnesia is very troublesome to use, but does not act injuriously on the plates: with such water, after working a short time, a thick scum forms on the top of the water; the steam having to rise through this carries with it particles of magnesia loaded with moisture, and excessive priming is the result. A partial remedy for this is the use of a scum-cock, but as the water-surface in a locomotive boiler is much broken up with stays, effective scumming cannot take place, and frequent emptying and washing-out of the boiler must be resorted to.

Water containing lime in various forms is most commonly used, and this generally forms a hard scale on the plates. There are many remedies for this in the shape of boiler-compositions, but all that is required is that the solids left in the boiler from the evaporation of the water should be in such a state that they can be readily removed. In stationary boilers this removal has been very successfully accomplished by means of petroleum, the only difficulty experienced being to get it into the boiler in a small enough quantity and in a finely divided state. It has been tried in locomotives by painting the inside of the water-tank with the oil, and, though it answered the purpose, some more convenient method will have to be found out before its use can be generally adopted.

The regular washing out of boilers is often neglected—simply blowing the water out of the boiler is by some considered all that is necessary. The practice of blowing-off boilers is a most barbarous and damaging proceeding; it ought never to be allowed, and the sooner blow-off cocks are entirely dispensed with, the better it will be for boilers. The steam should be allowed to go down quietly, the boiler emptied, and the washing-out not proceeded with until the boiler is nearly cold. The use of copper instead of iron rods in the mudholes would very materially save the threads in the holes, and the plates at the bottom of the fire-box shell.

The provision of efficient means for constant lubrication of all the working parts of an engine is a matter to which builders should give careful attention, but it is just as important that users should provide suitable lubricants. It is absurd to expect good results from the commonest mineral oil that can be obtained, and the use of such oil adds very seriously to the cost of repairs. The old-fashioned tallow cock is another thing that could very well be omitted, and sight-feed lubricators should be adopted, as they ensure a constant supply of oil to the steam-cylinders.

Much might be written as to the proper method of cleaning engines, but it is impossible within the scope of a short paper to deal exhaustively with such a complex structure as a locomotive-engine. Though the fringe of the subject has only just been touched, the foregoing paper may lead some of the members to take a greater interest in the subject, and possibly may tend to the better use and the less abuse of colliery locomotive engines.

**PHOSPHATE MARKET.**—*Le Phosphate* reviewing the phosphate situation concludes "It does not appear from present indications that any important change can take place in the phosphate market in the more or less near future. Present prices are not exaggerated, and can serve as a basis for average future transactions. If the future is to be forecast at all we are inclined to look for a rise, especially as regards the high grade phosphates."



### Important Session of the Mining Society of Nova Scotia.

An important meeting of the members of this Society was held in Halifax on 20th ulto. Mr. Charles Fergie, President, took the chair at 10.30 a.m. There was a fair attendance of members.

#### WORK OF THE GEOLOGICAL SURVEY IN N. S.

The Secretary said that in answer to the resolution passed at the last meeting endorsing the services of Messrs. Fletcher & Faribault, he had received the following reply from the Hon. Mr. Sifton:—

"MY DEAR SIR,—

"OTTAWA, 25th April, 1899.

"I have much pleasure in acknowledging the receipt of your letter of the 20th inst., containing copy of a resolution adopted at the annual meeting of the Mining Society of Nova Scotia with reference to the Geological Survey Department. I am pleased to know that the work of that branch of my department is appreciated, and shall certainly give your views as therein expressed my best consideration.

"Yours faithfully,

"CLIFFORD SIFTON."

#### ACCOMMODATION FOR THE LIBRARY.

The President intimated that in conjunction with the Secretary and Dr. McGregor and Dr. McKay, of the Institute of Science, they had had an interview with the Premier with respect to the provision of suitable accommodation for their library in the new Government building. The Premier regarded the matter favorably and had asked that the request be forwarded to him in writing.

A. A. HAYWARD—It will be in the new Government building?

THE PRESIDENT—Yes.

A. A. HAYWARD—On the Museum floor?

THE PRESIDENT—Yes. We want someone to associate with Dr. McGregor and Dr. McKay. I suggest the Secretary and Mr. Morrow.

THE SECRETARY—The Government will provide the proper stands and catalogue the books.

THE PRESIDENT—The Premier said not to let the matter hang over but to attend to it at once.

THE SECRETARY—We have numerous specimens of iron ore. Nobody sees them where they are now, and I think we could hand those over to the museum. They are of no use where they are now.

A. A. HAYWARD—I move that Mr. Morrow and the Secretary be empowered to make the necessary arrangements as to providing a room in the new Government building, the placing of our samples of ore in the Provincial Museum, and also the placing of our library in charge of the Provincial authorities.

C. H. STARR—I second the motion. This was agreed to.

#### NEW MEMBERS.

On motion the following gentlemen were elected new members of the Society:—W. C. Brine, D. C. Hood and G. L. Burrett.

#### DELEGATE TO PARIS CONFERENCE.

A letter from Mr. B. T. A. Bell, editor of THE CANADIAN MINING REVIEW, Ottawa, to the Secretary was read, intimating that he intended visiting Paris to attend the Conference of Mining Engineers to be held there in July next.

CHAS. ARCHIBALD moved that the Secretary be instructed to write Mr. Bell asking him to represent the Society as its delegate.

C. A. MEISSNER—I second the motion. The motion was adopted.

#### DATES OF MEETINGS.

CHAS. ARCHIBALD—I move "That the meetings of this Society in future be semi-annual, the annual meeting to be held on the second Wednesday in April and the other in December, the time to be arranged by the Council. Special meetings may be called by the President at any time."

W. L. LIBBEY—I second the motion. Agreed to.

#### THE METALIFEROUS MINES ACT.

THE PRESIDENT called on Mr. Stuart to make some remarks upon "The Metaliferous Mines Regulation Act." As Mr. Stuart and Mr. Wilson had gone carefully over the Act in question the meeting would be pleased to have their views.

GEO. W. STUART—We would like to call your attention to Rule 2 on page 19:

"The following provisions shall relate to the use of any explosive;

"(a) It shall not be stored in the mine."

Sometimes old abandoned tunnels are the best places in the world to stow explosives in. We thought that it might be changed to read in this way: "That it shall not be stored in any mine in operation."

A. A. HAYWARD—Perhaps that is what they intended to convey.

F. H. BELL—That is the reading of the present Act, but it is the law at the present time.

THE PRESIDENT—You cannot store it in a mine now?

GEO. W. STUART—No. There is no question about an old abandoned mine—a tunnel being the best place to store dynamite.

W. L. LIBBEY—These old abandoned tunnels have no connection with the mine?

GEO. W. STUART—No. "Not to be stored in any mine in operation," that is what we would prefer.

A. A. HAYWARD—He thought that would be better.

GEO. W. STUART—The next clause in connection with explosives reads as follows:

"(c) It shall not be taken into the mine except in a securely covered case or canister, containing not more than six pounds, and a workman shall not have in use at one time in any one place more than one such case or canister."

That is the Act now. We think that should be changed. Frequently in large mines they fire as much as 50 lbs. at once.

F. H. BELL—That is beyond the power of the revisors. We are not supposed to make any material changes in the law.

THE PRESIDENT—That was not in the old Act?

F. H. BELL—Yes.

GEO. W. STUART—I do not remember noticing it.

THE PRESIDENT—We do not object to it in the coal mines, but it is a different matter in gold mines. We use a large quantity.

C. E. WILLIS—I think 50 lbs. would be small enough limit.

A. A. HAYWARD—Yes. I am quite agreed with Mr. Willis on that.

W. L. LIBBEY—If you are going to take it down as low as 5 lbs. if it goes off someone will be hurt. It will not make any difference whether it is 5 lbs. or 150 lbs. The safety of human life would be better ensured by making a regulation like this: that each shift—each working shift—some one man should have sole charge of the dynamite, and no one else should be allowed to handle it. You will consider human life safer by that measure than by making a regulation as to the number of pounds or ounces to be carried down. We have never yet had an accident from the use of dynamite, and I think it is simply due to the fact that we only allow one man to handle it. I have had one man always to do the loading and firing on each shift.

A. A. HAYWARD—A small mine could not afford that.

W. L. LIBBEY—Yes. If you had four men, one man out of the four could do the loading and firing.

GEO. W. STUART—Do you think the following clause should be expunged?

"(d) It shall not be taken into the mine, etc."

C. E. WILLIS—That does not relate to dynamite at all; it relates to powder.

GEO. W. STUART—To explosives. What would you suggest?

W. L. LIBBEY—My suggestion is that that limit be expunged entirely. We know it would be impossible to pay attention to the law in that respect anyway.

A. A. HAYWARD—If you had 50 lbs. you would be amenable to the law if the law confined you to 50 lbs. The result would be the same if it exploded.

THE PRESIDENT—You must have a limit.

F. H. BELL—You must have some definite quantity fixed.

THE PRESIDENT—My opinion is, if they gave you 50 lbs. that would be ample.

W. L. LIBBEY—That is practically as much as you could carry at once.

GEO. W. STUART—You would have one man in charge of the explosives?

W. L. LIBBEY—Yes; and make him responsible.

A. A. HAYWARD—That is all right for a large mine.

GEO. W. STUART—All this refers to a mine that has over 12 men.

A. A. HAYWARD—In a small mine a man gets his load, takes it down and fires it. It would be an injustice to a small mine.

W. L. LIBBEY—This only refers to a mine that employs over 12 men.

THE PRESIDENT—Where 50 lbs. or more are used it should be in charge of a man.

B. C. WILSON—Instead of six pounds as in the present Act, we have drafted an amendment to read as follows:

"Explosives shall not be taken into any mine employing more than 12 men, in quantities beyond the operating or blasting requirements of any one day, or not to exceed 50 lbs. in all, also that one man shall be detailed who shall have special charge of the explosives when taken into the mine, as also of the firing."

GEO. W. STUART—There is a clause here that seems a hardship in some cases. It reads as follows, page 22, Rule 7.

"Rule 7 (1) Every road on which persons travel underground where the produce of the mine in transit exceeds ten tons in any one hour over any part thereof, and where the load is drawn by a horse or other animal, shall be provided, where there is not standing room of at least two feet, at intervals of not more than twenty-five yards, with sufficient manholes or with places of refuge."

A. A. HAYWARD—That applies to coal mines only?

GEO. W. STUART—No.

THE PRESIDENT—You should provide room where a man can get out of the way, or refuge holes.

GEO. W. STUART—Is it necessary to have two feet?

F. H. BELL—Yes; or a manhole.

THE PRESIDENT—If you get a stout man you will want all of two feet. I have had experience in this matter, and have been glad to get the two feet.

B. C. WILSON—If there is not two feet standing room you must provide a man-hole.

MR. JOHNSTON—Is it two feet from the rail or the side of the waggon?

THE PRESIDENT—Two feet from the side of the waggon.

GEO. W. STUART—We were thinking that less than two feet would do.

(It was then decided not to suggest any amendment to this clause.)

GEO. W. STUART—I would like to call your attention to Rule 21, page 28, which reads as follows:

"Rule 21. If more than twelve persons are ordinarily employed in the

mine below ground, sufficient accommodation shall be provided above ground near the principal entrance of the mine, and not in the engine house or boiler house, for enabling the persons employed in the mine to conveniently dry and change their dresses."

THE PRESIDENT—That is a change house.

GEO. W. STUART—Yes. We thought possibly that might be amended in this way "and not in the engine house or boiler house until partitioned off." This means that you have to have a separate building. This is a hardship where you are opening a mine up for a short time.

THE PRESIDENT—If you separate your boiler house off, that covers the Act.

F. H. BELL—Make it "room." Engine room or boiler room.

GEO. W. STUART—The Act will then read "and not in the engine room or boiler room." Those are all the changes we would suggest.

THE PRESIDENT—We have to thank Mr. H. F. Bell for being with us to-day. I think the revisors should be congratulated upon the good work they have accomplished. With regard to coal I consider the Act is as perfect as you can get it, and I think Mr. Stuart and Mr. Wilson can also say the same with regard to gold. It is very satisfactory. I must congratulate Mr. Bell and his co-workers for the trouble they have taken in the matter.

F. H. BELL—I feel extremely obliged to Mr. Fergie, the president of this Association, for his kind remarks. I think our greatest reward is the fact that the Act is appreciated by those who have to work under it. We have tried to give you a good Act and if we have succeeded I think we will be rewarded enough.

The Secretary was instructed to write a letter to the Government conveying the thanks of the Society for the efficient way in which the Mines Regulations Act had been revised, and submitting the few suggested amendments for their consideration.

The meeting adjourned until 3 o'clock.

#### AFTERNOON SESSION.

The members reassembled at three o'clock, the President in the chair.

#### WHAT BECOMES OF THE GOLD IN THE TAILINGS!

Mr. B. C. WILSON presented his paper, "What becomes of the Gold run out in the Tailings?" (reproduced elsewhere in this issue).

W. L. LIBBEY—I would like to ask Mr. Wilson for my own information whether or not cyanide would attach gold that is already amalgamated with the mercury?

B. C. WILSON—I think not extravagantly at all, but probably it would to some extent; but you will bear in mind that gold run off in the tailings is practically not amalgamated. It is attached to fine particles of quartz and concentrates—and it is in the concentrates that the greater portion of the gold is run off. I think the amount of free gold run off is not very large.

W. L. LIBBEY—Following your view of the case, whether the cyanide that was introduced in the batteries would really be likely to dissolve the gold that escaped—if I understand the theory right, the gold that escaped largely in the shape of what is called float gold, which in all probability is associated with mercury. And whether in the tremendous flush of water that has always been used in our mortars here with the low pitch of the plates—in fact the general milling practice is to use a flood of water through the mill (laughter)—whether it was possible that ever enough cyanide was used in any one mill here to make 5-100 of one per cent. as a solution I doubt it.

A. A. HAYWARD—The question to determine is whether the loss was in float gold or associated with concentrates.

W. L. LIBBEY—If it was attached to quartz I think the gold would be attacked by cyanides less than in many hours of action.

B. C. WILSON—In fact, I suppose, it is not many hours, but we may say years that there has been little quantities of cyanides going off year after year—that the action would be going on, and I infer that it has taken a great many years in almost all instances to cause that reduction. Now I may refer to one instance with which I am perfectly familiar, in which I took up certain tailings where they had concentrated by the natural action of the flow from the sluice from the mill.

W. L. LIBBEY—The drop of the sluice?

B. C. WILSON—Yes; and I got two ounces per ton out of them after they had laid there 10 months, and there was a portion which ran into the building which I could not remove without injury to the building, and some objection was raised to it and they remain there until the present time. Two years ago a gentleman in the employ of parties in Chicago, who went very carefully into the analyses of tailings through the country generally, stated that he had understood that there were anywhere from \$5.00 to \$10.00 per ton in the sand of Nova Scotia, but he had never been able to find a dollar. I know there are some tailings that have been laying 25 or 30 years which were worth a couple of ounces per ton—but a party who tried them said he only got \$1.20 per ton. In this case they had been nearly 30 years exposed.

W. L. LIBBEY—I have had some experience in treating tailings that had been 10 years exposed. In fact I treated something like 1,500 tons. Our treatment was to simply run the sand through the mortars to get them again to the free milling process over 14-ft. plates and then concentrate. Perhaps it is a crucial process. The result was somewhat surprising to me. While the tailings would assay on an average something like \$6.00 per ton, we recovered on an average about \$5.00. This was of course by amalgamation and concentration—and the assays of the tailings behind the concentrators showed conclusively what we lost was float gold, was free gold. They were tailings that not only had been milled 10 years ago and oxidized by the process of nature for ten years, but had been subjected again to crushing and amalgamation and then concentration. We simply, under the treatment of the tailings, did not get probably over one-half of the values. There is an argument for the cyanide process. Of course, if we had the tailings in sufficient quantities, I would even tackle cyanide again.

A. A. HAYWARD—Do I understand that the tailings at the end of the vanners ran \$5.00 per ton?

W. L. LIBBEY—They averaged better than \$2.00.

C. F. ANDREWS—You say your assays of your tailings in the first instance gave \$6.00?

W. L. LIBBEY—I said on an average.

C. F. ANDREWS—You obtained by extraction \$3.00, and you would lose the balance, \$3.00 worth. Would you not naturally suppose that the gold in the first assays was contained in slimes that had been laying in these piles of sands, and in re-milling neither your stamp nor concentrator would handle the slimes?

W. L. LIBBEY—No, I do not think so; because the particular dump was the result of milling with a loader's charge and cross screens, and the sand as it came from the dump was remarkably free from slimes which you could readily see with your eye, in the first instance, as float gold—it probably went off in the slimes as float gold, consequently you would not be able to handle it with the concentrators.

W. L. LIBBEY—I do not take much stock in the loss of gold by slimes.

A. A. HAYWARD—Did you ascertain the percentage of concentrates at the foot of the vanners?

W. L. LIBBEY—The percentage was considerably higher than it was in the ore.

A. A. HAYWARD—Would you not consider that the loss was due to improper concentration rather than to float gold? Did you ascertain the values of the concentrates at the tail of the vanners not concentrated?

W. L. LIBBEY—Yes. We assayed for free gold and refractory gold.

A. A. HAYWARD—What percentage of concentrates was still left in the tails?

W. L. LIBBEY—At the tails of the concentrators?

A. A. HAYWARD—If you had 2 per cent. at the head, what percentage would you have at the tails?

W. L. LIBBEY—We made something like 77 per cent.

THE PRESIDENT—You mean extracted.

W. L. LIBBEY—The concentrates contained in the sand. Of course when we read the advertisements of machine manufacturing companies they say 95 per cent. The men who sell these machines know they are not telling the truth.

C. F. ANDREWS—We had a little experience with respect to gold contained in slimes. The samples were kept in a bucket—the water was very slimey—the bucket was kept full and allowed to overflow. The tailings were allowed 24 hours to settle in the bucket, before we turned the water off to make an assay of the tailings. At the end of the 24 hours the water was heavy with slimes, and we did not think there could be any value left in the slimes in the water at the end of 24 hours. After the tailings were taken out of the bucket we saved the slimes and evaporated the water, leaving the slimes on the sides and bottom, and Mr. Mason assayed the slimes, and we found those slimes contained enough gold to enter into his future assays of those tailings. These slimes had been in the water standing 24 hours—at the end of that time they still contained enough gold to enter into his future assays—into his calculations.

A. A. HAYWARD—Might not those slimes still hold small particles of concentrates in suspension. Slimes are usually composed of finely divided concentrates.

C. F. ANDREWS—This was a very slaty ore.

A. A. HAYWARD—Are not slimes finely divided particles of concentrates?

F. H. MASON—Not necessarily. They may be finely divided particles of gangue.

A. A. HAYWARD—The losses are in the finely divided concentrates.

B. C. WILSON—That is what I understand.

W. L. LIBBEY—When we were pumping out the Brookfield mine, after it had been full of water 6 or 8 years, we had some of the mine water assayed, and the assayer declared that the water was worth something over \$2.00 per ton. That is trailing out your slime journey a little farther.

W. L. LIBBEY—I have no means of disproving the statement.

GEO. W. STUART—I fear from the drift of the discussion that we have lost a view of the question that Mr. Wilson in his admirable paper intended to bring out, and that is the question of whether or not the excessive abuse of cyanide has not been the cause of a great loss of gold. While the paper is on the line of enquiry, yet it strikes me there is a firm conviction in the mind of Mr. Wilson that the excessive use of cyanides has been the result of a great loss of gold that has gone off in solution. Am I right?

B. C. WILSON—That is the idea.

THE PRESIDENT—I do not think Mr. Libbey questions that.

W. L. LIBBEY—Yes, I do question it some. The cyanide was largely used in the batteries.

B. C. WILSON—Sometimes in the batteries.

C. F. ANDREWS—I have seen them throw large lumps (of cyanide) into the water.

GEO. W. STUART—That was the custom 5, 10 or 15 years ago, to use large quantities of cyanides in the batteries.

B. C. WILSON—The excessive use.

W. L. LIBBEY—Cyanide that will not attack gold in mechanical combination—chemically, if you will—I say, mechanical combination with the various forms of sulphides—cyanide will not attack that gold, and I equally believe that cyanide does not appreciably attack gold that is in association with mercury.

B. C. WILSON—Might not oxidation—?

W. L. LIBBEY—In other words, gold in association with mercury, cyanide will not attack it.

GEO. W. STUART—My experience is that cyanide destroys the vitality of mercury, and I think that all gold that is coated with any matter which prevents it from amalgamating freely is eventually, and generally after it passes through the screen, liberated from the coating and has not the opportunity to become amalgamated with the mercury from the fact that the mercury also is affected materially by the excessive use of the cyanide—it eventually passes off not only in the slimes but in the tailings—and eventually it becomes dissolved and passes off in solution.

W. L. LIBBEY—You make a new proposition to me when you say that cyanide destroys the vitality of mercury.

GEO. W. STUART—I am strongly of that impression. I am convinced of that from my experience. I may be in error.

W. L. LIBBEY—My impression is if you take sick mercury, which you all understand very well, from a retort or clean-up, that there are no two things that will revivify it as well as cyanide—

GEO. W. STUART—In exceedingly limited quantities.

W. L. LIBBEY—Just simply give it a bath of cyanide. There are some very good authorities who say that is the first and best and last thing to use to rejuvenate mercury.

GEO. W. STUART—Common salt is a much better thing.

W. L. LIBBEY—I will tell you what I use. I always wash the mercury in cyanide and then use metallic soda. They are the two best things to use. When you tell me that cyanide destroys mercury, if I had some sick mercury here I could prove to you that it does not.

GEO. W. STUART—Understand me, in excess.

F. H. MASON—I think you are in error, Mr. Stuart. A saturated solution of cyanide will quicken mercury. I do not agree with Mr. Libbey that cyanide will not dissolve gold locked up in sulphurets.

W. L. LIBBEY—Commercially, I mean.

F. H. MASON—I do not agree with you there either.

W. L. LIBBEY—I may be in error, but I will be glad to be set right.

F. H. MASON—I mean it is the practice to use cyanide where the amalgamation has failed, and even by pulverizing extremely finely you cannot attack the ore by amalgamation.

W. L. LIBBEY—How do you account for the fact that cyanide failed at Brookfield?

F. H. MASON—It is a selected solvent. There are other things in the ore which decomposes the cyanide—amongst other things sometimes arsenical ores decompose and others will not.

W. L. LIBBEY—You are hitting me right back.

A. A. HAYWARD—One would infer that the practice was to constantly supply the mortar with cyanide. From reading the minutes I would get the impression that the practice in Nova Scotia in the past has been to constantly apply cyanide in the mortar continuously. I have been in the Province eighteen years and during that period the practice has been to shut the mill down and rub the plates with cyanide and occasionally throw a lump of cyanide in the mortar just before the clean-up. This application made once or twice during the 24 hours would certainly have little effect upon the total amount of ore crushed during the 24 hours.

B. C. WILSON—Still the quantity of cyanide there has gone out in the main mass of tailings and has there become concentrated and has percolated and gone through the mass. It has filtered practically right down through it.

A. A. HAYWARD—The sands as they go from one end of the sluice would naturally run off in all directions. It is not probable that the application of cyanide once or twice during the 24 hours would permeate the entire mass. I think really in the past it is a hobby we have been riding too far in the losses of tailings in Nova Scotia. I think this cry is used by parties owning property which has been worked in the past and is now for sale. I have assayed a large quantity of tailings in this Province and am satisfied that no such values are contained in the sands as are in many cases represented. Every Spring brings a crop of men into the country to purchase sands, with the usual result that they are obliged to sell their shirt to get out of town.

W. L. LIBBEY—I have a large quantity and expect to run them away through the mill again next summer.

B. C. WILSON—I have not heard of any profitable work in tailings in Nova Scotia except from my friend here on my right (Mr. Libbey.)

W. L. LIBBEY—Do not say profitable.

B. C. WILSON—I may say that I am in \$400 in tailings—that is to say that a party came and paid me \$400.

GEO. W. STUART—Mr. Hayward, you do not mean to say, however, that there has not been a very considerable loss heretofore in tailings?

A. A. HAYWARD—I mean to say where a lode carries sulphurets the the greatest loss will be found due to the gold in the sulphurets and not float gold. There has been instances of bad milling and too fine crushing has caused slimes and a great amount of gold has been taken away, but the general practice throughout the Province has not been bad compared with other parts of the world.

W. L. LIBBEY—I know of an instance that happened four or five months ago. An assayer was employed to go to a certain mill here in the Province that is running today—they had some rich ore in the mine and took out a test crushing. The assayer made as correct a sampling as he could of the ore which ran about \$80 to the ton. They milled it and the tailings ran about \$70 to the ton.

GEO. W. STUART—How were they taken?

W. L. LIBBEY—The tailings were taken at the tails of the plates. During the whole run the samples were taken constantly—that is I have his word for it. I know what his methods were and I have every reason to believe that the samples were taken honestly.

A. A. HAYWARD—Take the samples in crushing the Lawson at Montague when there were 20 oz. to the ton, 3 to 4 ounces were covered by free milling process and still tailings were found to contain 15 ounces.

W. L. LIBBEY—This ore would give you nothing in sulphurets, it was practically free milling. The percentage of refractory gold in it was very little.

GEO. W. STUART—Was there any cyanide used in the batteries in the mortars during the process?

W. L. LIBBEY—I do not know that, but I think not. I feel morally certain that there was not, but I would not state that as a positive fact.

GEO. W. STUART—Where cyanide is used in the batteries the action is not active enough to have any particular effect on the amalgamation in the batteries. While I think that after passing through the batteries the possibilities are that the gold would become free from the action of the cyanide. I think that it takes a reasonable time for the cyanide to take effect, and relieve the coated gold and bring it into the condition when it would become practically free.

A. A. HAYWARD—I do not think that is really the action. I think the action is not to make it free but dissolve it.

W. L. LIBBEY—I do not use cyanide at all as a dressing on the plates.

What I do use is a combination of cyanide and sulphate of iron, copperas, for taking off copper stams.

B. C. WILSON—Do you find that successful?

W. L. LIBBEY—It seems to work very nicely. I condemn the use of cyanide; it is a dangerous thing.

GEO. W. STUART—I would like to ask Mr. Mason, as an authority, about how long it is necessary for cyanide to have an appreciable action on gold?

F. H. MASON—Take for instance gold leaf—if you put that in a solution of cyanide, a weak solution, it will dissolve under a quarter of an hour.

GEO. W. STUART—Which would be a much greater time than it would be maintained in the mortar?

F. H. MASON—Yes.

B. C. WILSON—It would be the action on the sands outside.

A. A. HAYWARD—The percentage used in the mortar would be small.

B. C. WILSON—The small quantity would have greater results from the length of time it would have to operate on those sands. Dear knows how long it may stay there filtering through.

A. A. HAYWARD—It may have to run a long distance.

T. R. GUE—I saw in a laboratory in Brooklyn, New York—a strip over a quarter of an inch wide, such leaf as is used by dentists, which is much heavier than the ordinary gold leaf—a strip three inches long dipped down in cyanide. In 15 seconds it turned purple and dissolved.

GEO. W. STUART—What percentage of cyanide was used?

T. R. GUE—Three per cent. Am I right in saying cyanogen?

F. H. MASON—I was not referring to a solution as strong as that. Was there anything else in that?

T. R. GUE—No. I telegraphed to Mr. Hardman to come down, and we spent some very hot hours in a close laboratory in Brooklyn, and saw it done, and the results were wonderful; but Hardman and myself had very great doubts of its practicability on a commercial scale.

W. L. LIBBEY—Was that Professor Kendall?

T. R. GUE—That was Professor Kendall.

W. L. LIBBEY—I would venture to say that Professor Kendall did use a re-agent in connection with the cyanide.

T. R. GUE—Mr. Hardman saw it done.

F. H. MASON—Had you Professor Kendall's word for that?

T. R. GUE—No; I had Mr. Hardman to verify it.

W. L. LIBBEY—I know Professor Kendall did use per oxide of sodium. It will intensify the action very much. I have tried it with gold leaf myself, and while without the per oxide of sodium, the ordinary two or three per cent. would take hours to dissolve gold leaf. In a few minutes with the per oxide of sodium it would dissolve.

A. A. HAYWARD—Mr. Mason, do you believe the sands were ever as rich as we are led to believe they were?

B. C. WILSON—I am free to believe that the loss of gold 25 years ago was much greater than now, for the reason that the ore treated then was richer than now—and they could afford to lose more. I have seen tailings that showed considerable gold by even washing them over, by simply re-amalgamation through the stamps—and I think that some mills were more carelessly handled than others, in the same way that some mills today are making a greater saving than others in the Province—but I think today the loss of gold is small in our treatment.

A. A. HAYWARD—The losses in years gone by were not as great as one would be led to believe.

B. C. WILSON—I think there is room for doubt.

F. H. MASON—I think until concentrators are put in considerable value is lost. The concentrators made quite a difference with Mr. Libbey.

W. L. LIBBEY—We saved a good deal of free gold on the concentrators as well. If you follow your assays right down through you will find you are saving free gold on the concentrators.

A. A. HAYWARD—Does it not come down to the fact that the greatest loss is due to the mechanical combination of the gold in the sulphurets? Are not the losses practically from the sulphurets?

W. L. LIBBEY—Yes; but not in our own case. It is a surprise to me to know that there is so much loss in free gold and that free gold we are saving on the concentrators too.

B. C. WILSON—It is quite inconsistent to say that persons could lose \$6.00 a ton out of ore that did not contain that originally.

A. A. HAYWARD—On 5 or 9 oz. ore today are we doing any better in free milling practice than in older times?

B. C. WILSON—I have none to practice on.

A. A. HAYWARD—Take the Golden Lode, that ran 10 oz. to the ton and the loss was \$4.60 per ton. When you take into consideration the value of the ore the percentage of loss was really small—but it was found the greater part of this loss was due to the association of the gold with the sulphurets. Mr. Mason made the assays; he will bear me out.

C. F. ANDREWS—Was there a large percentage of concentrates in that ore?

A. A. HAYWARD—No, not much.

GEO. W. STUART—It is unfair to question the loss of gold in general as being larger—that is, gold that has gone out in the tailings—as larger than that that has been saved in the batteries and on the plates. There are some leads which, in my opinion, there has been no difficulty whatever in saving from 75 per cent. to 95 per cent. of the gold in the ore, while in other leads it has been impossible to save by the ordinary process of the amalgamation in the batteries and on the plates 50 per cent. of the amount of gold that is contained in the ore. It depends entirely upon the character of the ore. Hayward has referred to the loss in the Bell lead in Montague. I worked that lead myself for a short time, and while saving but some 6 or 7 dwts. in the batteries and on the plates by the first process after taking the concentrates which were saved in a very crude process in sluices and in settling basins within a few hundred feet of the mill, I was able to obtain, after a reasonable time after oxidation, after being mixed with common salt, I obtained double the amount of gold that I obtained in the first process owing to the fact that the gold was largely held in the sulphurets. That was my experience with the Lawson lead, and it appears to me that is somewhat your own experience.

A. A. HAYWARD—Yes. We used to get from 3 to 4 ounces in the first milling and we found from 15 to 16 ounces still remained in the tailings.

W. L. LIBBEY—Held in mechanical combination.

A. A. HAYWARD—You will find pieces of gold actually black that will bend like hoop iron, and yet you would never know they were gold. I certainly came to the conclusion that most of the gold is contained in the sulphurets, and I am also of the opinion that the sands in Nova Scotia are not as rich as we are led to believe they are.

A vote of thanks was then passed to Mr. Wilson for his valuable paper. After discussing some matters of detail the meeting adjourned.

## ROSSLAND DISTRICT.

The new year has been entered on in Rossland most auspiciously. For the first time in its history the camp can boast of three dividend paying mines—the Centre Star having joined the old reliable Le Roi and War Eagle—and there is a good prospect that before 1900 closes the list of dividend paying mines in Rossland will be further increased by the addition of the Iron Mask, Columbia and Kootenay, West Le Roi (Josie and Number One), Velvet, I. X. L., and possibly the East Le Roi (Nickel Plate), Evening Star and Giant. The shipments of ore are just about double what they were a year ago. For the first thirteen days of the year they total 9,249 tons, made up as follows:—Le Roi, 3,577 tons; War Eagle, 2,979; Centre Star, 2,148; Iron Mask, 372; Monte Christo, 273; Giant, 50; I. X. L., 25; and Evening Star, 25. All of these mines, with the exception of the Monte Christo, are now steady shippers, and the output from each will be increased materially as time goes on. The Josie, Number One, Columbia, and Kootenay, Nickel Plate, Gertrude, Portland, Velvet, and probably one or two other properties will also join the list of regular shippers during the year. As the total shipments for 1899 were something over 150,000 tons, it may confidently be predicted that the output of the camp for 1900 will exceed 300,000 tons, of an aggregate value of \$6,000,000.

### THE CENTRE STAR.

The Centre Star has been producing about 1,000 tons of ore per week for several months now, and this rate of production will be maintained for the present. A dividend of one cent a share, or \$30,000 has been declared for the month of January, payable February 15th, and a dividend of a like amount will, it is understood, be declared monthly hereafter. The general opinion in Rossland is that the Centre Star is a much greater mine than the War Eagle, and it is predicted that when its new machinery is all installed and in working order it will speedily surpass the War Eagle's record as a dividend payer.

### LE ROI MINE.

Since Bernard McDonald took charge of the B. A. C. properties some changes in the plan of development have been made. The most notable of them, perhaps, is the abandonment of the scheme to sink a perpendicular four compartment shaft on the Black Bear ground through which to work the Le Roi, Black Bear, Josie, West Le Roi and Number One mines. Instead of this Mr. McDonald is enlarging the double compartment incline shaft, which has been made from Black Bear tunnel to the 700 foot level of the Le Roi to five compartments. The workings on the 800 and 900 levels are being extended as rapidly as possible to connect with this shaft, which will then become the main working shaft of the mine. The foundations for the new 40-drill compressor and boiler house are being laid.

### IRON MASK.

The Iron Mask has been very fortunate in discovering new ore bodies: late in the 300-foot level west, and in a crosscut from the 300-foot level east. In the former workings the ledge shows a maximum width of 7 feet, having been drifted on for about 50 feet, and in the latter the ore body proved to have a width of 5 feet and exceptionally high values. A new 150-horse power electric motor has been installed to replace the old 100-horse power motor, which was unequal to the requirements of the mine.

### I. X. L. MINE.

A rich pocket was found last week in the stope above the number one level in the I. X. L. mine, and nearly a ton of ore, every bit of which showed more or less visible gold, has been taken out. A half ton of ore taken out of a similar pocket some weeks ago was sent to the smelter recently and yielded over \$1,200, or at the rate of \$2,400 to the ton. The ledge has been crosscut on the number three level and is now being drifted on, and an upraise to connect with the number two level is being made. In another month the ore chute which is about 160 feet long, of an average width of 30 inches, and an average value of about \$25 per ton, will be thoroughly opened up from the number three level to the surface. About 25 tons a week are being shipped, most of this ore being taken out in the course of development.

### EVENING STAR.

The first shipment of ore since the Evening Star passed under the control of George B. McAuley of Carboo (Camp McKinney) fame, was made last week. The ore came from some new workings on the 125-foot level. The management believes that they have at last got the ledge in place and feel confident that the property will shortly be developed into a mine.

### THE GIANT.

Nick Tregear, late superintendent of the Le Roi, who is managing the Giant for (U. S.) Senator Turner and his associates, who now have the control of the property under option, appears to be meeting with great success. A large body of good grade ore has been opened up on the surface on the hanging wall side of the ledge, and some of this has been shipped to the Northport smelter. A crosscut is now being driven from the 50-foot level in the old shaft to tap this ore body.



## THE CALIFORNIA.

The surface improvements at the California have been completed and work is now being carried on in the main tunnel, which is in 265 feet, and in the shaft which is down 60 feet.

## THE JOSIE.

Development work has been resumed in the Josie on the 300 and 500 levels, the new 150 horse power electrical hoist having been installed and found to work perfectly.

## COLUMBIA AND KOOTENAY.

A station is being cut out in the number six tunnel of the Columbia and Kootenay to begin sinking the three compartment shaft by means of which the mine will be opened below that level. An upraise is also being made to the number five level.

## THE NICKEL PLATE.

At the Nickel Plate the shaft is being widened to three compartments from the 400 foot level to the surface, and the work of sinking to the 600-foot level has been begun.

## NUMBER ONE.

Development work on the Number One is being confined to the 300 and 400 foot levels, though it is the intention to begin sinking to the 600 right away, a new 300-gallon per minute Jeansville pump having been installed on the 400-foot level.

## MINING NOTES.

The Monte Christo has temporarily stopped shipments.

Drifting and crosscutting is being done on the St. Elmo.

On the Sunset No. 2 drifting is in progress on the 100-foot level.

Crosscutting to the new ledge is still being prosecuted on the 300-foot level in the Deer Park.

On the 450-foot level in the Jumbo the drift has now been extended for 60 feet along the vein.

A shaft is being sunk on the Evening Star on Big Sheep Creek. It is now down about 60 feet.

Work is being steadily prosecuted on both the Velvet and Portland, on Sophia Mountain.

A number of properties are being developed in the Norway Mountain district, near Sheep Lake, and on Murphy and Sullivan Creeks. This is the first winter anything of the kind has been attempted.

Mining machinery men say that contracts for four 40-drill compressors will be let shortly by companies in the Boundary district.

All talk of a strike in this camp seems to have died out to the great relief of everybody.

The stock market has been fairly active since the new year, I. X. L. and Giant being the favorites.

H. W. C. J.

## LARDEAU DISTRICT.

An unprecedented mild winter, coupled with a wonderful deficiency in our usual snow-fall so far, has acted distinctly as a drawback on mining operations in this locality; for not only is it nearly impossible to transport the ore after extraction to the nearest shipping point, but the trails themselves can hardly be travelled over, the snow is so soft. Beginning as usual with the Big Bend district, from which so much was confidently expected this winter, it is most disappointing to relate that the Boston & B. C. Copper Company have suspended operations, and their men have left the claim in Standard Basin after all the preparations made for a steady winter's work. The cause of this is not made public, but the rumour has it that the company failed to make a certain instalment on their bond when it became due. It is most sincerely to be hoped that this property will not in consequence be thrown up altogether, for the result of the work done last fall, and till the mine was shut down, certainly indicates a large body of ore though the vein was not struck, nor expected so to be in the distance driven. It is said that efforts are being made to induce other capital to take hold of the property, and it is to be hoped such efforts will be successful, as the surface showing is undoubtedly very good. The cessation of work on the Boston & B. C. Company's claim renders the Big Bend exceedingly quiet this season, as that was the only company employing any quantity of men; the Adair group being idle, and the Carnes Creek Consolidated working less than half a dozen hands.

From Illecillewaet there is not so much as a rumor of work. It is however, much more satisfactory to find that the Lardeau and Duncan Lardeau district is active, and though the quantity and quality of the snow interfere materially with moving the ore, yet it is being moved and shipments are being made from one or two mines. No doubt the general activity of this camp is probably due to the expected early advent of two opposition railroads, a great part of both of which has been completed, though no work is being done on them at present, but the richness of the ore—usually galena with much grey copper—is attracting outside attention, and some London (Eng.) capital is very likely indeed to find its way there. In addition to this rich argentiferous ore, there were several claims staked quite late in the fall that wonderful values in gold, which as is so often the case accident developed. The quartz ledges had been known for some time, but as galena was the only thing expected, nothing else was looked for and the ledges left as they were. An assay however, that was asked for on a sample of rather better looking material than the bulk of it, yielded such returns in gold that

the ledges were neglected no longer and are being developed; the assay value bearing out the surface results. There was some temporary trouble at the Silver Cup recently, and many of the men were laid off; but whatever the difficulty was it was smoothed over and the usual force is at work again, to continue it is to be hoped all the winter.

The Beatrice, Ethel, and some others intend to ship all the ore they can this winter, which will keep the camp alive. The mine however, in this camp, which really seems destined to be a marvel is the Nettie L., often referred to previously. As stated in last month's notes, the long lower tunnel was in 500 feet; on continuing this to cut No. 1 vein which is the one near the surface from which ore is now being stoped, a vein about a foot thick of quartz with galena and grey copper was met with assaying over 250 ozs. silver per ton, and several dollars in gold. When this was passed, the same apparently barren schist formation was found that occurs on the surface between the veins—some 20 to 40 feet thick—so that there seems every probability that the conditions at the surface are continued to at least that depth, which will be most satisfactory to the shareholders. Here again the extraordinary mildness of the season has prevented more than a few tons of that ore already sacked, being brought to the nearest shipping point. No doubt it is one of the vicissitudes incidental to mining, that when everything looks first rate, and all contingencies provided for as far as possible, the weather itself interferes with the profits almost, but not quite, in hand. The ore is there, however, beyond any question. One very noticeable feature about this property is that the owners ("The Great Western Mines, Ltd.") have not gone to any extravagance in their arrangements. There are no highly paid officials, and no sons or brothers who must have a job found for them whether they are worth it, or the mine can stand it, or not. Instead, many of the men have taken a large part of their wages in shares, and the manager has done the same. If more companies in British Columbia were handled as economically (but with no miserly action) there would be fewer Waverly and Tangier disasters, and their kindred.

East Kootenay hardly comes under this head, but it is very satisfactory to note the valuable nature of the many claims as proved by development. It is impossible here to enumerate the properties known, nor in the absence of more definite information than is at present at hand, would it be right to do so, but there seems no doubt that the neighborhood round about Toby, Horsethief, and other near by creeks falling into the Upper Columbia River, is highly mineralized and coming rapidly to the front as a producer. A promised branch from the C.P.R.'s Crow's Nest line up to this district would render transportation comparatively easy, and enormously develop the country.

In common with almost if not quite every other town in Canada, Revelstoke has had a most successful "Patriotic Concert" in aid of the Mansion House Fund, and war news is looked for—perhaps naturally—with more interest than the story of a new and rich find, while even in the isolated camps the advent of a bundle of newspapers is hailed with unbounded satisfaction. It is most earnestly to be desired that this unfortunate war may be brought to a successful (for us) and speedy conclusion.

A. H. H.

## LAKE OF THE WOODS.

Since last writing two mining deals have been put through at Rat Portage. The Pritchard-Scovill-Moore property near Cariboo Lake, a few miles north-west of the Virginia mine has been put under option to some parties connected with The Great Granite Company, who own a large tract of mineral land in the Shoal Lake region. The price is \$20,000 for four-fifths of the property, comprising two mining locations of about 50 or 60 acres each. Of this sum \$3,000 has been paid down, with the next payment to follow on 1st of August, and balance on September 1st, next. The property is quite undeveloped, except for a few shallow pits. Mr. Reynolds, who has been placed in charge of field operations by the optionees, started for the mine on the 15th instant with a large outfit of supplies, and will upon arrival at once proceed to erect mining camps, &c., and start in to mine.

The other deal was on a property in the vicinity of Star Lake, in Manitoba, south-west of Ingolf Station on the C.P.R., and not far from the Ontario boundary. An option was given for a large sum, although only \$500 in cash was paid down. The property belonged to Tom Moore, an old prospector in that region, and the deal on the other side was put through by Mr. Peters, the amalgamator, Rat Portage.

*The Triggs.*—The shaft is down 170 feet, and is going down at the rate of twelve inches a day under three shifts of three men each, single hand drillers. The drift is in 70 feet from the crosscut in one direction, and driving in the opposite direction was begun a few days ago. The camp numbers thirty men now. A fine shaft house has been erected with lumber cut by the new saw-mill at the mine; also, a fine office building, part of which is set apart as living apartments. The mine is equipped with a Lidgerwood hoist, No. 5 Cameron pump, and a blower. I should have said that the drifting is done by two ten hour shifts, the advance being about 12 inches in the 24 hours. Mr. Farr, late of St. Paul, and the secretary of the company now, has taken up his residence in Rat Portage.

*Imperial.*—At the beginning of the year the main shaft was down 70 feet, and work is now in progress, a contract for sinking having been given at \$27 per foot. At the 70 foot point, a crosscut of 31 feet has been made in one direction, and of 25 feet in the opposite direction. The intention is to sink the shaft to the 200 ft. point.

*Virginia.*—From the 200 ft. point in the shaft the drift is in about 35 feet. Much of the work at this mine has been done by contract. The rates now are: \$20 per foot for sinking, and \$12 for drifting, hoisting done and everything furnished by the contractor.

The acting superintendent, Mr. Rayburn, was in town lately and said the vein was looking very well indeed.

*The Monax.*—Sinking is progressing under the superintendence of Mr. Israel Gagne, one of the original owners. The vein improves with depth,

and some very fine samples have been taken out, while the average across from wall to wall is very good.

*Nora.*—Work stopped about the beginning of the month. Some time during the past autumn a miuer singlehanded and alone, in fifteen days sunk an 8 ft. by 4 ft. shaft to a depth of 8½ ft. from the surface, in a rock of average hardness.

There is about four inches of snow about the Lake of the Woods, making excellent sleighing on the ice, which is all clear and solid material, without any mixture of slush. On the portages another 6 or 10 inches of snow is needed. There has been no case of horse or man breaking through the ice this winter.

*The Wabigoon Star* states that the Shores Syndicate is still hard at work making ready at the King Locations on Sturgeon Lake. North of Ignall on the C. P. R. two stopping houses are being built on the road out to the lake, and at the mine sinking was to have begun on the three shafts on the 15th January.

Rat Portage, January 20th, 1900.

J. M.

**Vancouver and British Columbia General Exploration Company.**—The third ordinary general meeting of the shareholders was held yesterday (Friday). Mr. Patrick Comisky presided, and the proceedings were purely formal. The report adopted for the year ended 30th September last, stated that no new business of moment has been actually done. Although the manager has examined and reported on a large number of properties in different parts of British Columbia, so far he has failed to find anything that he can recommend to the directors as being suitable to the requirements of the company. The manager, Mr. Fraser, owing to the labour strike in the Slocan district and the general position of affairs, decided not to recommence the developments of the Reade and Tenderfoot leases during the past season, especially as the adjoining mines, which have been working for some considerable period, are proving to a great extent, by their developments, the value of the former property. It is therefore hoped that by next season the most advantageous method of opening up the claims may be determined.

**Asbestos and Asbestic Company.**—A circular issued to the shareholders states that the trading of the company for the six months ending 30th September last, resulted in a net profit of £108. It has been found necessary to continue the policy of turning out as much as practicable of asbestos without producing large quantities of asbestic, which cannot be promptly sold. The demand for short fibre referred to in the circular of 30th November, 1898, and at the annual meeting in July last, has continued; and at present the company is able to sell all it can produce and is making arrangements which it is believed will lead to an increase in the production. In the matter of asbestic the demand is increasing, as the value and importance of the material as a wall plaster become more fully appreciated. The progress is slow; but

it is believed abestic is gradually forcing its way into general use. Referring to a claim against the vendors which the directors were instructed to make, it is advised that the matter has been complicated by the commencement of an action against the company at the instance of a shareholder. This action is being defended by the company.

**The Extinction of Gob Fires.**—At a recent meeting of the Midland Institute of Engineers, Mr. W. H. Chambers, the president, read a paper on "Gob Fires," basing his remarks on his own experience of them at Denaby Main Colliery. Gob fires, he said, were one of the most dreaded contingencies of the perilous operation of coal mining, and as the exhaustion of the more accessible seams rendered it necessary to go to the greater depths, the liability to gob fires would be increased in corresponding ratio. Referring to his first experience of such a disaster some 30 years ago, it was found that the closing of the seam and the filling of the mine with carbon dioxide was quite ineffectual in putting an end to a gob fire. The shafts were closed for months, but as soon as the ventilation of the mine was restored, the fire burnt as fiercely as ever. The fire had simply remained latent whilst deprived of oxygen. No plan would extinguish underground fires unless means were provided for cooling the hot material by the application of substances which could absorb the heat until the temperature was lowered sufficiently to stop combustion. He showed how walling up had failed in early fires at Denaby Main, and said the only possible method of dealing successfully with a gob fire was to attack it in its incipient stage, to get the shovels to work, and to exhaust every means to utterly extinguish a fire in a mine before resorting to an attempt to prevent its encroachment by walling, and then leaving it to smoulder on. If the opening out of the old workings had been delayed three months, Denaby Main Colliery would have been lost forever.

**Copper in Steel.**—The influence of small percentages of copper in steel was the subject of a paper contributed to the American Section of the International Association, by Mr. A. L. Colby. This gentleman's investigations go to show that small percentages of copper have no deleterious effect upon the physical properties of steel. From a shaft in which there was .565 per cent. of copper, test specimens were cut, and it was found that these specimens showed the usual ductility of steel, and their tensile strength was from 64,000 to 68,000 lb. per square inch, an elongation in two inches of 28½ to 34 per cent. Other specimens of higher carbon steel with similar copper contents were tested without showing any deleterious influence. The bending and quenching tests of bars cut horizontally were satisfactory; but some bent transversely to the direction of rolling developed cracks. The material was also successfully welded. The author was also referred to experiments which showed that there is little tendency for copper to segregate from a steel ingot. He thinks that good steel may contain as much as 1 per cent. of copper without suffering, provided only that the sulphur content is not high, in which case the metal is liable to crack in rolling. But even if the sulphur is as much as .05 per cent. in steel in which as much as .075 per cent. of copper is present, there is not much danger of cracking while being rolled.

FIRST QUALITY IN ALL LINES

# Mining Machinery and Supplies

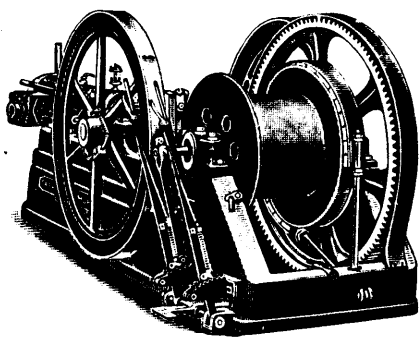

**GASOLINE**

Engines  
Hoists  
Air Compressors  
Pumping Plants

**STEAM**

Engines  
Hoists  
Pumps  
Boilers

Our Combined Geared Gasoline Engine and Hoist, and Combined Gasoline Engine and Air Compressor, especially adapted for Mining Purposes . . . .

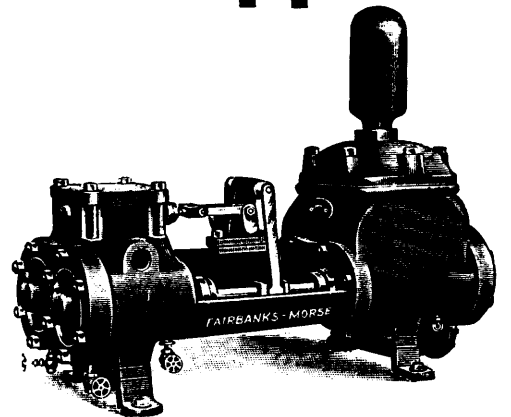

## FAIRBANKS' STANDARD SCALES

MINING CARS

SPIRAL RIVETED PIPE

CAR WHEELS

PIPE AND FITTINGS . . .

# FAIRBANKS, MORSE & CO.

Chicago, Cleveland, Cincinnati, Louisville, Indianapolis, St. Paul, Minneapolis, St. Louis, Kansas City, Omaha, Denver, San Francisco, Los Angeles, Portland, Ore.

HALL MINES, LIMITED.—At the annual meeting of the shareholders held last month:—

The Chairman said:—It is a matter of much regret to me that my fellow directors that we have again, at the close of another financial year, to report the disappointment of the expectations of more profitable results from the working of our mine and smelter, which we were encouraged to entertain and to express to you at the commencement of the year. Several causes have conjoined to account for our failure to realise those expectations. And, further, of the £50,000 we expected to obtain from the sale of the debentures for more vigorous development of the mine, and the placing of our account with our bankers on a more satisfactory basis, £25,000 only has been realised, the whole of which sum has virtually been appropriated to the reduction of our overdraft, so that development work has been altogether dependent upon output from our mine as heretofore, and consequently has unavoidably not been carried on as vigorously as we purposed it should be, and as was urgently advised by Mr. Hardman, who now criticises the board for not having fully carried out his recommendations. Nevertheless the amount of development work actually done this year exceeds that of last year, and almost its entire cost has been defrayed from our output without any direct aid from the issue of debentures, and a balance of £9,027 is carried forward after payment of all charges. Development is the one great need of our mine. In a recent report Mr. Hardman, whilst renewing his confident estimate of the value of our mine, urges the paramount necessity of making development subservient to output, being, of course, unaware of the condition of the company's finances, which has precluded the full carrying out of his recommendations. Upon his advice the Board appointed as successor to Mr. Davis, on his resignation, Mr. J. R. Gifford, who, being thoroughly acquainted with Mr. Hardman's views, will be able to carry out more effectually than any stranger whom we might have appointed could do, the suggestions made by Mr. Hardman for opening up the mine and effecting economies. I would impress upon your consideration the fact that we are, at the present time, carrying on our operations entirely out of the proceeds of our mine and smelter, and that, in order to more thoroughly push forward the development, and at the same time strengthen our position, it is absolutely necessary that we should be placed in funds for that purpose. The unissued balance debentures (some £25,000) is a resource which the shareholders ought, therefore to consider as the means for carrying this out. The security is, as you are aware, an absolute first charge on our property, and I strongly advise the shareholders to adopt this means of strengthening the company and enabling us to prosecute the development of the property so strongly urged by all our expert advisers.

Mr. J. R. Drake having seconded the motion for adoption of the balance sheet and statement of accounts for the year ended 30th September last.

Mr. Charles Harvey (consulting engineer) said that in the preceding year the reserves were estimated at 9,200 tons, against 18,700 tons this year. They had extracted in the current year 32,700 tons, which left them in a better position to-day, under this head, by 9,500 tons. Between September, 1898, and September of this year they had mined at the rate of over 100 tons per working day, and the whole of this ore had been taken from virgin ground. He wished to emphasise this fact so as to impress upon the share-

holders the possibilities of the mine if vigorously and systematically developed. It was no use blinking the fact that they had been working the mine at high pressure, and too much from hand to mouth for economical mining. Their smelting capacity was equal to 350 tons per day, against the output of 100 tons, which told its own tale. For the next twelve months development should be vigorously carried on, more with the object of creating large reserves than of making an immediate output. Undoubtedly the company has been seriously handicapped for want of funds and the introduction of the eight hours' shift system, which was felt by every mine in British Columbia, and which had materially altered the immediate position of affairs in respect to their company. Although the capacity of their smelter plant was much above the requirements to treat the ores from the Silver King for some time to come, they appeared to be fortunate in adopting lead smelting. If they might rely on the estimates and figures furnished, the profits from this source would be very large and make them in time independent of the mine for dividends. In this instance he thought they must rely on Mr. Croasdale's judgment if he was confident of acquiring all the lead and silver ore sufficient to run their large smelter in full blast. The shareholders must not entertain the idea that the Silver King was exhausted, or was of no value; it had immediate possibilities. If they would only reflect for a moment that the output of 33,000 tons had actually been extracted from the ledge that had been developed during 1899, and that they were better off by 9,500 tons in reserves than in September, 1898, they must acknowledge they had substantial reasons for believing everything that was encouraging in the future of the property. He had interviewed several mining experts and other gentlemen who had returned from British Columbia, some of whom had examined the mine, and without exception they all spoke in praise of the outlook of the Silver King and in favour of the general rich prospects and of the bold and encouraging feature of the ledge, and he hoped with a little more patience they would be recouped for their losses and disappointments.

DOMINION MINING DEVELOPMENT AND AGENCY.—The report of this company for the year ended 30th June last, to be presented at the third meeting to be held on 29th inst., states that there has been a loss of £1,788. This poor result has been brought about mainly by the heavy loss of about £5,317 made on the portion of the reindeer skin clothing sent to Dawson City for sale. The balance of the skins are still on hand, and it is hoped that they will be realized at a profit. During the year 12,301 shares of the company have been subscribed for and allotted. Considerable further development has been done in connection with the Cascade water power, and arrangements have been made for its sale, with all rights attached thereto, to the London and B. C. Goldfields, who will in due course bring out a separate company to provide sufficient capital to complete the necessary works for supplying power in the district. This sale will result in a considerable profit to this company. The Atlin Lake Company, Limited, was promoted by this company in March last to take over certain interests acquired, and to further develop and prospect in the Atlin district. The company has been successful in acquiring most valuable claims, and has recently increased its capital to £50,000.

Are You Confronted with a Difficult Ore-Separating Problem?

**THE WETHERILL MAGNETIC SEPARATING PROCESS** MAY PROVE THE SOLUTION

...APPLY TO...

WETHERILL SEPARATING CO.

52 Broadway, New York.

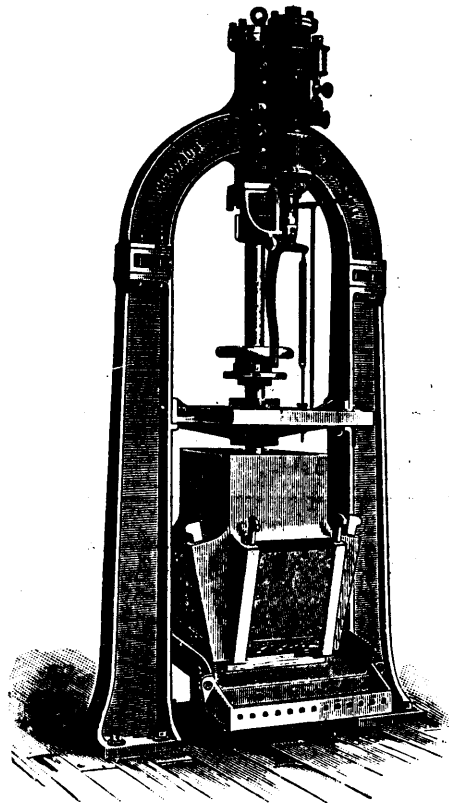

## THE WOOD STEAM STAMP

IS DESIGNED FOR DURABILITY.

- It will wear as long as any vertical engine.
  - It is simple in its operation.
  - It will save values equal to a gravity mill.
  - It has three large screen discharge openings.
  - The Wood Ore Feeder will feed wet or dry ore equally well.
- We refer you to Dwight, Furness & Co., Guanajuato, Mexico; also G.E.M. Mining Co., Cherry, Arizona. These parties are operating several of our mills.

Address all Communications to

**H. A. NEWKIRK & CO.**

1442 Monadnock Block, CHICAGO, ILL.

**THE E. P. ALLIS CO., Builders,**  
Milwaukee, Wis.

(H. A. Newkirk & Co. having exclusive rights to U.S. and foreign countries.)

**McPherson, Clark, Campbell & Jarvis**

Barristers, Solicitors, &c.

OFFICES:

Trusts and Guarantee Building

16 King St. West, Toronto, Can.

Cable Address: CLAPHER, TORONTO.

## RELIABILITY

Makes the worth in EDDY'S MATCHES—seeing our name on the box begets confidence. Lots of other makes where you get more wood for your money—many imitations too, put up "like EDDY'S," but they are very different in use.

This name guarantees the quality.

**The E. B. EDDY CO. Ltd.**

HULL, CANADA.



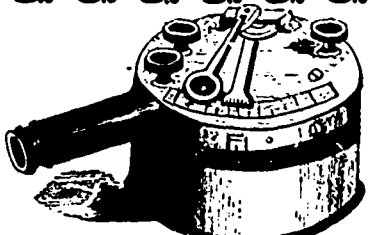

**SURVEYING, MINING  
AND  
ENGINEERING : : :  
INSTRUMENTS. : :**

Accurate and Most Improved . . .

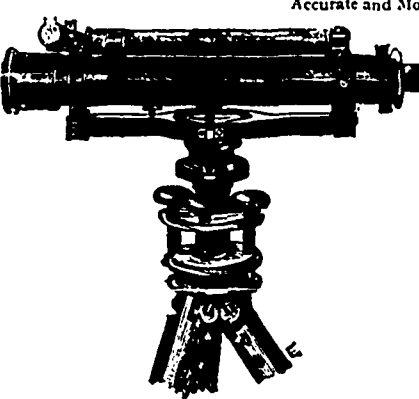

**MINING TRANSITS.**  
میراں

Complete Line of Engineers  
Instruments and Supplies.  
Reasonable Prices. SEND  
FOR CATALOGUE. . . . .

میراں

**Hearn & Harrison**  
NOTRE DAME ST.,  
MONTREAL, QUE.

**Canada Atlantic Ry.**

THE SHORT FAVORITE ROUTE  
BETWEEN

Ottawa and Montreal.

**8** TRAINS DAILY **8**  
EXCEPT SUNDAY  
And Sunday Train Both Directions  
PULLMAN BUFFET PARLOR CARS

Close Connections at Montreal with Trains for

Quebec, Halifax, Portland

And all Points EAST and SOUTH.

FAST THROUGH SERVICE BETWEEN

Ottawa, New York and Boston

And all NEW ENGLAND POINTS

through Buffet Wagner Sleepers between Ottawa and New York.

Baggage checked to all points and passed by customs in transit.  
For tickets, time tables and information, apply to nearest ticket  
agent of this company or connecting lines.

E. J. CHAMBERLIN, J. E. WALSH,  
General Manager. Ass. Gen. Passenger Agt.  
C. J. SMITH, Gen. Traffic Manager.

**THE BABCOCK & WILCOX**

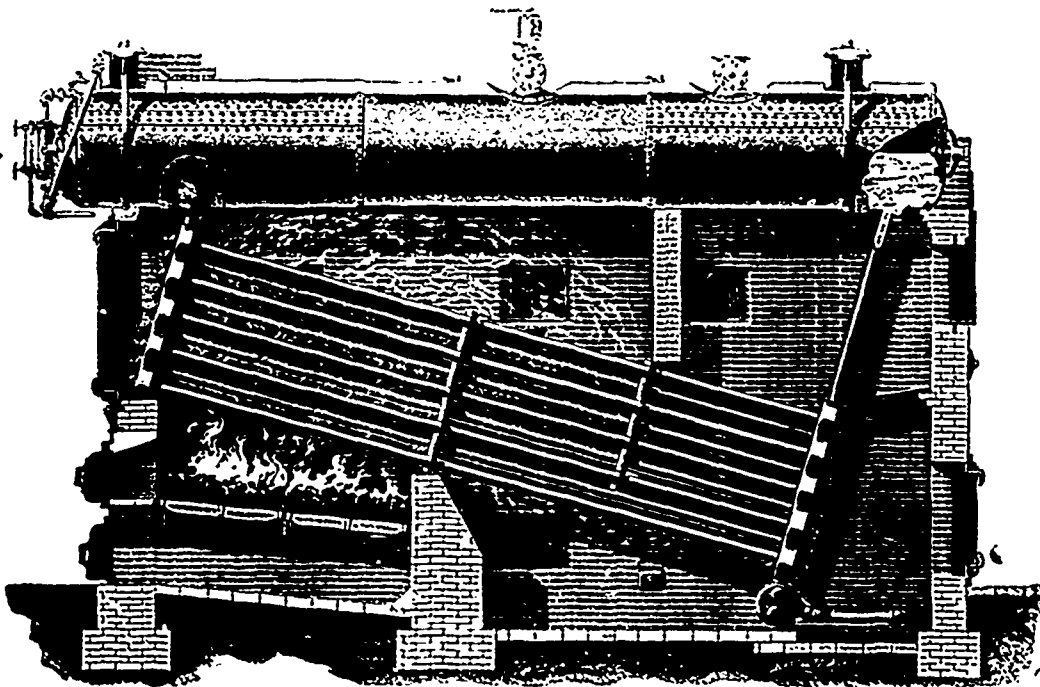

WATER TUBE

**STEAM . . .  
BOILER . .**

was first patented by Stephen Wilcox, in  
1856. Nearly **2,000,000 H.P. now  
in use.** Has no equal for MINES  
RAILWAY, SMELTERS, ELECTRIC  
LIGHTING or other power purposes.

Large book "STEAM" sent free of  
application.

**BABCOCK & WILCOX, LIMITED, ENGINEERS AND BUILDERS.**

Head Office for Canada: 202 ST. JAMES STREET, MONTREAL.

The Original and Only  
Genuine Hair Belt . .

**Lancashire Patent Hair Belting**

"GENUINE OAK" Tanned Leather Belting.

Is specially adapted to Exposed Situations

**D. K. McLAREN . . Manufacturer and Mill Furnisher**

OTTAWA.

TORONTO.

MONTREAL.

# WALKER BROTHERS

ENGINEERS AND IRONFOUNDERS

PATENT AIR-COMPRESSING ENGINES, GAS-COMPRESSING ENGINES AND VENTILATING FANS

FISHER & WALKER'S PATENT FRICTION CLUTCHES, UNDERGROUND HAULAGE and GENERAL MINING MACHINERY.



## WALKERS' PATENT AIR-COMPRESSING ENGINES

Single or Compound Steam Cylinders with Corliss or Slide Valves. Air Cylinders arranged for the "Single" or "Two Stage" system of compression, the latter having an Intermediate Cooling Apparatus. [Engines constructed either with trunk frames or box girder plates.]

The system of compressing air by STAGES effects a great economy in power and fuel, with a considerable reduction of temperature in the compressed air. The air is first compressed in the Low Pressure Cylinder, then its temperature is reduced in the Intermediate Cooler, and afterwards it is again compressed in the High Pressure Cylinder.

WALKER BROTHERS have supplied a large number of compressors on this principle for Mining and other purposes, with the most satisfactory results. Nearly all they at present construct are on the stage system, both for Mining and Colliery purposes.

The latest form of their patent Valves, which is a great improvement on the earlier types, affords special advantages for compressing air, or gas, by the stage system.

WALKER BROTHERS have had thirty years' experience in the design and construction of air and gas compressing machinery, and their attention has been constantly given to perfecting the details.

The Air Valves, as at present made (to their latest patents), are an immense improvement upon those supplied twenty years ago.

The aggregate Power of the Compressors at work, about 550 in number, exceeds 250,000 Indicated H.P.

WALKER BROTHERS have re-modelled over 100 Air-Compressing Engines originally constructed by other Engineering Firms.

## THE BLACKWALL TUNNEL

For the construction of the Tunnel, Six Air-Compressing Engines were erected. The largest Two Pairs of Compound Engines, were supplied by us.

Messrs. S. PEARSON & SON, the Contractors for the construction of the Tunnel, have kindly written to us, as below, with reference to the quality and working of our Machinery :-

S. PEARSON & SON, CONTRACTORS.

Messrs. WALKER BROTHERS, PAGEFIELD IRONWORKS, WIGAN.

BLACKWALL TUNNEL WORKS, EAST GREENWICH, S.E.

May 10th, 1897.

DEAR SIRS,—We are pleased to confirm what we told you verbally the other day, viz: that we consider the Air Cylinders and Valves of your Compressors to be the best for such work as we have been carrying out on the above Contract.

One of your Engines ran for almost a year without stopping, and it gives us great pleasure to thus testify to the good qualities of the plant which we purchased from you.

We are, Dear Sirs, Yours faithfully. (Signed) pro S. PEARSON & SON, E. W. MOIR.

# PAGEFIELD IRON WORKS, WIGAN, ENG.

REPRESENTATIVE FOR CANADA:

FRANCIS T. PEACOCK, M.E., 204 St. James St., Montreal

**Education Goes to You.**

There are ambitious young men and women who cannot afford to stop work to prepare for a high position. Don't stop; you study "between times," and we guarantee you a thorough course through

**EDUCATION BY MAIL**

in Electrical, Mechanical, Steam, Mining, Civil Engineering; Metallurgy, Art, Architecture, Practical Newspaper Work, English Branches, Stenography, Machine Design, and Mechanical Drawing. Low price; easy terms. **Sent free to those who enroll now, a complete drawing outfit worth \$11.10 or other premiums.** Mention subjects interested in when writing to



**THE UNITED CORRESPONDENCE SCHOOLS**  
154-156-158 Fifth Ave., NEW YORK, for Catalogue No. 110.

**MICA MINE FOR SALE**

A good going Mica Mine, 67 acres. Title perfect; within half mile of railway. Apply

**G. S. DAVISON, 193 Sparks St., OTTAWA, ONT.**

**Michigan College of Mines.**

**A STATE TECHNICAL SCHOOL.** Practical work. Particular attention to practical men who wish to study Special Subjects. Elective System. College year, 45 weeks. Tuition for residents \$25, non-residents \$150. Instruction in Mathematics, Physics, Chemistry, Assaying, Metallurgy, Drawing, Ore Dressing, Mineralogy, Petrography, Geology; Mechanical, Electrical, Civil and Mining Engineering, etc. Summer work in Metal and Wood Working, Stamp Mill, Surveying, Testing of Materials, Steam Engineering and Field Geology. For catalogues giving occupation of graduates, address

**MRS. F. H. SCOTT, Sec'y,**  
Houghton, Mich.

**J. Bertram & Sons**  
**Canada Tool Works,**

**DUNDAS, ONT.**

Builders of Iron

••••• **WORKING MACHINERY**

.... FOR....

REPAIR SHOP, MACHINE SHOP, SHIP YARDS  
BOILER SHOPS, ENGINE WORKS,  
CAR SHOPS, FORGE WORKS.

OUR EQUIPMENT AND WORKS ARE THE LARGEST IN CANADA.

OUR LINE OF

**MACHINE TOOLS**

WILL SUPPLY A SHOP COMPLETE.

**MONTREAL**  
... STORE: **321 St. JAMES STREET.**

B.C. Agency: The Wm. Hamilton Mfg. Co., Vancouver, B.C

Full Information obtained at the Above Addresses. Write for Prices

**The Mining Journal**

**RAILWAY AND COMMERCIAL GAZETTE**

**ESTABLISHED 1835.**

THE MINING JOURNAL circulates all over the world amongst Miners, Engineers, Manufacturers, and Capitalists.

THE MINING JOURNAL offers unusual advantages for Advertising Sales of Mineral Properties, Machinery, Commercial Notices, Inventions, and all articles for the use of those engaged in Mining, Engineering, and Mechanical work.

THE MINING JOURNAL was established more than 65 years ago, and still maintains its position as the leading organ of the world's Press devoted to mining and its allied interests.

Annual subscription, including postage, £1.8s.

Advertisements 1 inch, single column, \$1. per insertion.

46, QUEEN VICTORIA STREET

**LONDON,**

**ENGLAND**

**IMPULSE WATER WHEELS . . .**  
**STEAM AND POWER PUMPS .**  
**GAS AND GASOLINE ENGINES**  
**ELECTRIC LIGHT ENGINES . .**  
**MILL ENGINES . . . . .**  
**BOILERS . . . . .**

**THE SMART-EBY MACHINE CO. LIMITED**

191 Barton St. East,  
Hamilton,  
Ont.

**Correspondence Solicited.**

**NOW READY**

9th EDITION

**CANADIAN MINING MANUAL**

A complete Text-Book of the Mining Companies of Canada and Newfoundland.

**Chemical and**

**Assay Apparatus**



ZINC, CYANIDE and SULPHURIC ACID  
FOR CYANIDE PROCESS.

**COMPLETE ASSAY OUTFITS.**

THE HAMILTON-MERRITT PROSPECTOR'S OUTFITS. . . .

Becker's Balances and Weights.

Battersea Crucibles and Muffles.

Hoskins' Gasoline Furnaces.

Kavalier's Bohemian Glassware.

Munktell's Swedish Filters.

OUR 1897 CATALOGUE ON APPLICATION

**Lyman, Sons & Company**

380, 382, 384, and 386 ST. PAUL STREET,  
**MONTREAL.**



# CANADIAN MINING INSTITUTE

The Annual General Meetings of the Members of  
The Canadian Mining Institute will be held in the

**CLUB ROOM, WINDSOR HOTEL, MONTREAL**

—ON—

**Wednesday, Thursday and Friday, 7th, 8th, 9th March, 1900**

**SESSIONS AT 10.30 A.M., 3 P.M. AND 8 P.M. DAILY**

**ALL MINING MEN CORDIALLY INVITED**

The following, among others, will contribute to the syllabus of proceedings :—

Mr. S. S. FOWLER, S B, M.E., Nelson, B.C.  
Mr. BERNARD McDONALD, M.E., Nelson, B.C.  
Dr. W. L. GOODWIN, Kingston, Ont.  
Mr. GERALD V. HOPKINS, Silica, B.C.  
Mr. J. L. PARKER, M.E., Cranbrook, B.C.  
Mr. J. C. GWILLIM, M.E., Ottawa.  
Mr. R. G. McCONNELL, B.A., Ottawa.  
Mr. R. W. BROCK, B.A., Ottawa.  
Mr. J. BURLEY SMITH, M.E., Montreal.  
Mr. CHARLES FERGIE, M.E., Westville, N.S.  
Mr. O. E. S. WHITESIDE, M.E., Anthracite, N.W.T.  
Mr. ALEXANDER SHARP, Rossland.

Mr. ARCHIBALD BLUF, Toronto.  
Mr. F. T. SNYDER, M.E., Chicago.  
Mr. EUGENE COSTE, M.E., Toronto.  
Mr. GEORGE E. DRUMMOND, Montreal.  
Dr. W. T. GIBBS, Buckingham.  
Mr. E. C. MUSGRAVE, Omenica, B.C.  
Mr. J. B. PORTER, Montreal.  
Mr. R. E. CHAMBERS, M.E., Bell Island, N'f'd.  
Mr. A. P. LOW, B.A. Sc., Ottawa.  
Mr. C. A. MEISSNER, M.E., Sydney, C.B.  
Mr. W. F. FERRIER, Rossland.

AND OTHERS.

**SINGLE FARE ON ALL CANADIAN RAILWAYS**

**SPECIAL RATES AT ALL HOTELS**

For further particulars see programmes or apply to

**B. T. A. BELL, Secretary.**

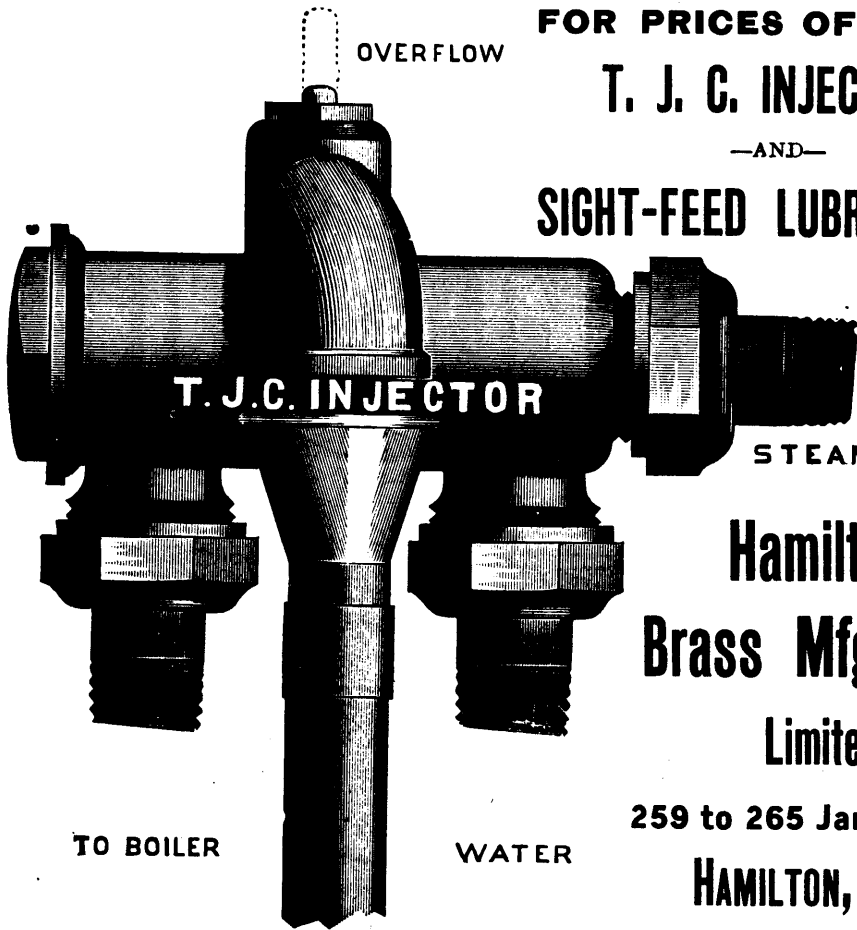

FOR PRICES OF  
**T. J. C. INJECTORS**  
—AND—  
**SIGHT-FEED LUBRICATORS**

Write  
to  
the

**Hamilton  
Brass Mfg. Co.  
Limited**

259 to 265 James St. W.  
**HAMILTON, ONT.**

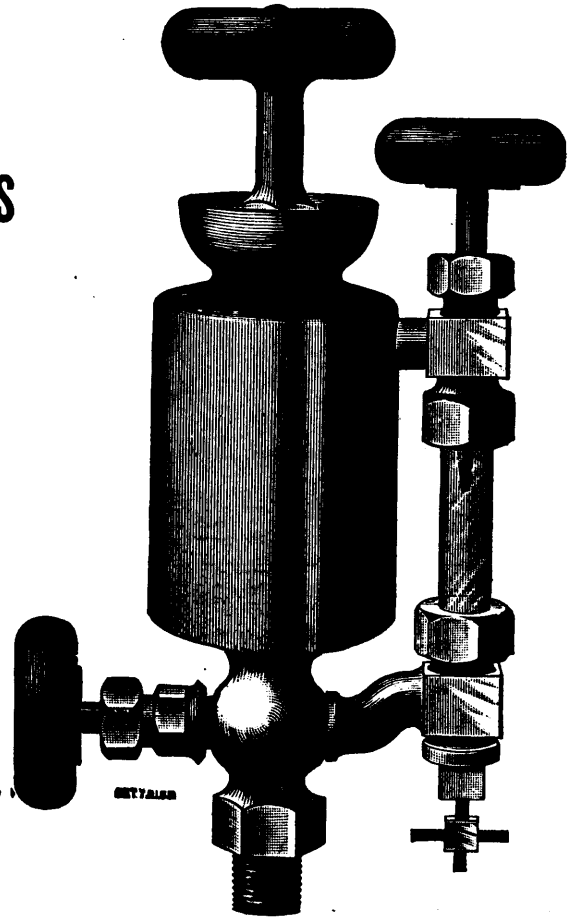

# HAMILTON POWDER COMPANY.

Manufacturers of Sporting, Military and Blasting

**GUNPOWDER, DUALIN, DYNAMITE and ECLIPSE.**

Dominion Agents for Safety Fuse, Electric Blasting Apparatus, Etc.

Office: 103 St. Francois Xavier St., Montreal.

Branch Offices and Magazines at all Chief Distributing Points in Canada.

## Ottawa Powder Company, Ltd.

\*\*\*\*\*  
ESTABLISHED 1891.  
\*\*\*\*\*

MANUFACTURERS OF **DYNAMITE AND TRIOLINE.**

Dealers in Safety Fuse, Platinum Fuses, Detonators, and all Blasting Supplies. All Orders Promptly Attended to Under Guarantee of Excellence.



CENTRAL OFFICE:

**CENTRAL CHAMBERS OTTAWA, ONT**

# **PATENTS** The Toronto Patent Agency, Limited

CAPITAL - - - - \$25,000.00.

The only Incorporated Joint Stock Company in Canada doing a general Patent Agency business.

**Patents Obtained. Patents Sold on Commission. Joint Stock Companies Formed.**

**Valuation and Prospects of any Patent furnished on application.**

Write for Terms to **THE TORONTO PATENT AGENCY** HEAD OFFICE—79, 80, 81, 82 Confederation Life Building, TORONTO, CANADA.

Branch offices in all the principal towns and cities in Canada and the United States. Correspondents in England and on the continent.

# SCHOOL OF MINING,

## KINGSTON, ONTARIO.



*The Following Courses are offered*

**1—Three Years' Course for a Diploma in**

- (A) Mining Engineering.
- (B) Analytical Chemistry and Assaying.

**2—Four Years' Course for a Degree in**

- (A) Mining Engineering.
- (B) Chemistry and Mineralogy.
- (C) Mineralogy and Geology.

**3—Post-Graduate Course for the Degree of**

Doctor of Science (D.Sc.)  
For further information see the calendar of Queen's University.

**4—Prospectors' Course.**

The School offers to Mine Foremen, Assayers, Prospectors and Mining Men generally, Special Courses of Instruction beginning January 9th, 1900, and continuing eight weeks.

Next Session begins October 2nd,  
... 1899 ...

The School is provided with well equipped Laboratories for the study of Chemical Analysis, Assaying, Blowpiping, Mineralogy, Petrography and Drawing. In the Mining Laboratory the operations of Crushing, Amalgamating, Concentrating, Chlorinating, Cyaniding, etc., can be studied on a large scale.

FOR CALENDAR OF THE SCHOOL AND FURTHER INFORMATION APPLY TO

**Dr. W. L. GOODWIN,**  
DIRECTOR

SCHOOL OF MINING, KINGSTON, ONTARIO

# ...FAIRBANKS... STANDARD SCALES

Railroad Scales  
Wagon Scales  
Car Scales  
Tramway Scales  
Platform Scales  
Army and Navy Scales  
Assay Balances

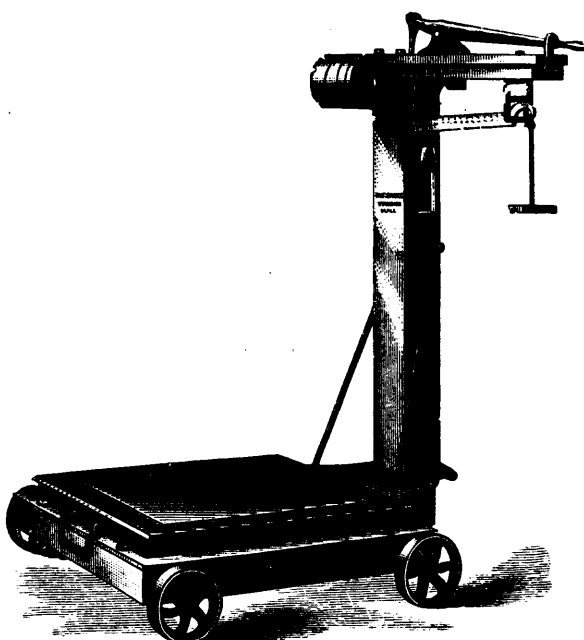

## SPECIAL BARGAIN

We offer, subject to previous sale, two 80,000 lb. Railway Track Scales which are now in use on a Railroad and are to be replaced by 200,000 lb. scales. Will be put in good order and sold cheap.

... SEND FOR NEW CATALOGUE ...

# THE FAIRBANKS COMPANY

## MONTREAL.

ADDRESS REPLIES TO MINING DEPARTMENT.





## PROVINCE OF NOVA SCOTIA.

Leases for Mines of Gold, Silver, Coal, Iron, Copper, Lead, Tin

—AND—

## PRECIOUS STONES.

TITLES GIVEN DIRECT FROM THE CROWN, ROYALTIES AND RENTALS MODERATE.

### GOLD AND SILVER.

Under the provisions of chap. 1, Acts of 1898, of Mines and Minerals, Licenses are issued for prospecting Gold and Silver for a term of twelve months. Mines of Gold and Silver are laid off in areas of 150 by 250 feet, any number of which up to one hundred can be included in one License, provided that the length of the block does not exceed twice its width. The cost is 50 cents per area. Leases of any number of areas are granted for a term of 40 years at \$2.00 per area. These leases are forfeitable if not worked, but advantage can be taken of a recent Act by which on payment of 50 cents annually for each area contained in the lease it becomes non-forfeitable if the labor be not performed.

Licenses are issued to owners of quartz crushing mills who are required to pay

Royalty on all the Gold they extract at the rate of two per cent. on smelted Gold valued at \$19 an ounce, and on smelted gold valued at \$18 an ounce.

Applications for Licenses or Leases are receivable at the office of the Commissioner of Public Works and Mines each week day from 10 a.m. to 4 p.m., except Saturday, when the hours are from 10 to 1. Licenses are issued in the order of application according to priority. If a person discovers Gold in any part of the Province, he may stake out the boundaries of the areas he desires to obtain, and this gives him one week and twenty-four hours for every 15 miles from Halifax in which to make application at the Department for his ground.

### MINES OTHER THAN GOLD AND SILVER.

Licenses to search for eighteen months are issued, at a cost of thirty dollars, for minerals other than Gold and Silver, out of which areas can be selected for mining under lease. These leases are for four renewable terms of twenty years each. The cost for the first year is fifty dollars, and an annual rental of thirty dollars secures each lease from liability to forfeiture for non-working.

All rentals are refunded if afterwards the areas are worked and pay royalties. All titles, transfers, etc., of minerals are registered by the Mines Department for a nominal fee, and provision is made for lessees and licensees whereby they can acquire promptly either by arrangement with the owner or by arbitration all land required for their mining works.

The Government as a security for the payment of royalties, makes the royalties first lien on the plant and fixtures of the mine.

The unusually generous conditions under which the Government of Nova Scotia grants its minerals have introduced many outside capitalists, who have always stated that the Mining laws of the Province were the best they had had experience of.

The royalties on the remaining minerals are: Copper, four cents on every unit; Lead, two cents upon every unit; Iron, five cents on every ton; Tin and Precious Stones; five per cent.; Coal, 10 cents on every ton sold.

The Gold district of the Province extends along its entire Atlantic coast, and varies in width from 10 to 40 miles, and embraces an area of over three thousand miles, and is traversed by good roads and accessible at all points by water. Coal is known in the Counties of Cumberland, Colchester, Pictou and Antigonish, and at numerous points in the Island of Cape Breton. The ores of Iron, Copper, etc., are met at numerous points, and are being rapidly secured by miners and investors.

Copies of the Mining Law and any information can be had on application to

**THE HON. C. E. CHURCH,**

Commissioner Public Works and Mines,

HALIFAX, NOVA SCOTIA.

# THE SNOW STEAM PUMP WORKS,

MANUFACTURERS OF

Steam Pumps, Pumping Engines and Hydraulic Machinery.

General Agents for Canada, DRUMMOND, McCALL & CO., Montreal.

Local Agent F. R. MENDENHALL, Rossland, B. C.

Pumps Kept in Stock at Montreal and Rossland.

**MONTREAL...**

**PIPE FOUNDRY CO.**

LIMITED.

MANUFACTURERS OF...

CAST IRON  
WATER AND GAS

**PIPES**

oooooooooooo

OFFICES:

**CANADA LIFE BUILDING**

**MONTREAL.**

WORKS: LACHINE, QUE.

PRICES ON APPLICATION.

**The Montreal Car Wheel Co.**

MANUFACTURERS OF .

**CHILLED**

Works:  
LACHINE,  
Que

Offices:  
CANADA LIFE  
BUILDING.

**WHEELS**

For Railroad, Electric Car, Street Railway and  
Lumber Truck Service, Etc.

THOMAS J. DRUMMOND, General Manager.

**MONTREAL.**

**CANADA IRON FURNACE CO. Limited**

MANUFACTURERS OF

Brand:

"C. I. F."

Three Rivers.

**CHARCOAL PIG IRON**

ALSO MAKERS OF PRESSED AND REPRESSED BRICKS.

**Canada Life Building**

**MONTREAL.**

PLANTS AT

RADNOR FORGES, QUE.

LAC A LA TORTUE, "

THREE RIVERS, "

GRANDES PILES,

GEO. E. DRUMMOND, Managing Director and Treasurer.

# THE DOMINION WIRE ROPE CO. LIMITED

MONTREAL, CAN.

Manufacturers of "LANG'S" PATENT WIRE ROPES

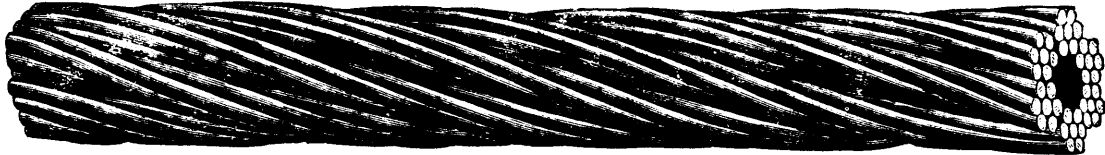

FOR COLLIERY AND GENERAL MINING PURPOSES.

ALSO BEST STEEL WIRE ROPES FOR ALL PURPOSES.



BRANCH OFFICES: Vancouver, B.C.  
Rossland, B.C.

Winnipeg, Man.  
Toronto, Ont.

Ottawa, Ont.  
Halifax, N.S.

CATALOGUE ON APPLICATION.

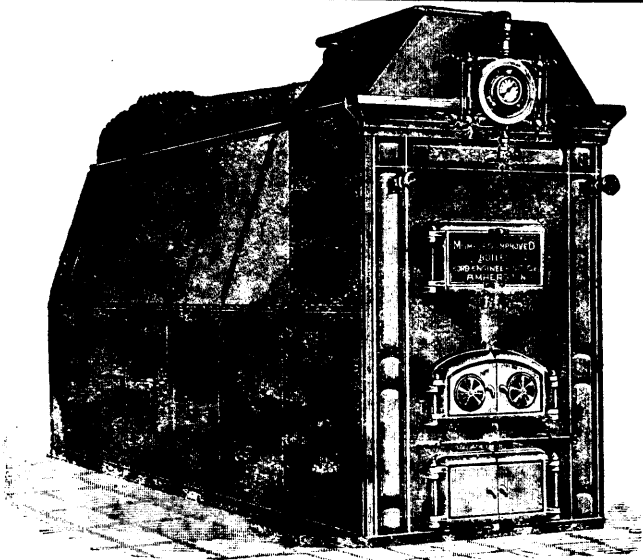

## The Mumford Improved Boiler

Has internal firebox, water circulation similar to a Water Tube boiler, large heating surface and special arrangements for preventing and removing scale. Tests show high economy. Built with sheet steel case or for brick casing as desired.

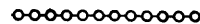

ROBB ENGINEERING COMPANY, Limited  
AMHERST, N.S.

# FRASER & CHALMERS

Mining Machinery,  
Stamp Mills,  
Smelters,  
Rock Crushers,  
Riedler Pumps  
and  
Air Compressors

CHICAGO, ILL., U.S.A.

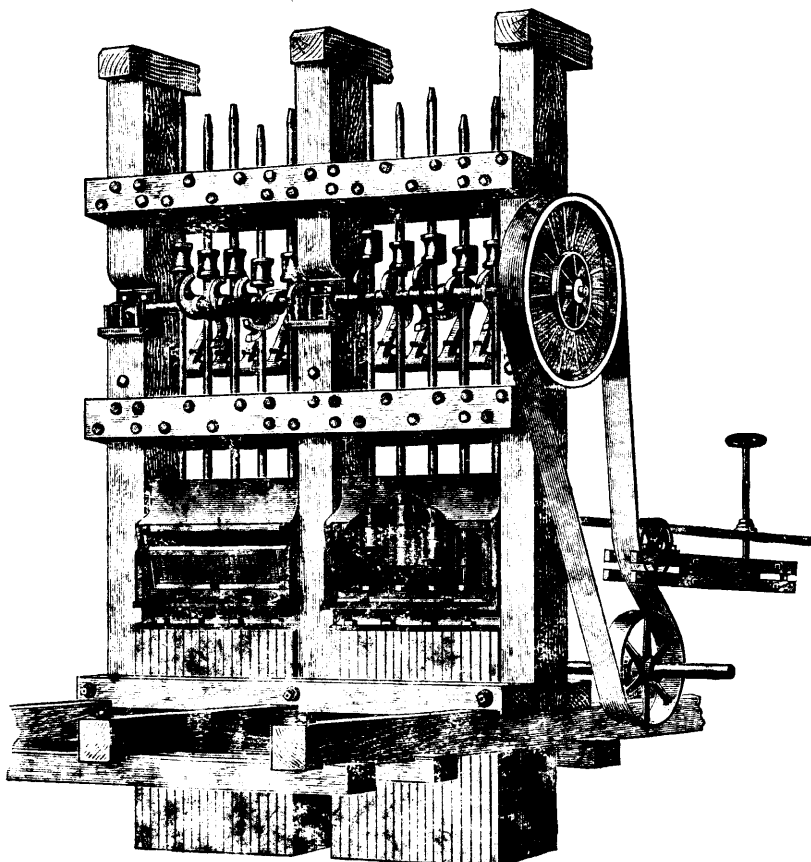

AND LONDON, ENGLAND.

Hoisting Engines,  
Frue Vanners,  
Sederbohm, Adams and Wood Boilers,  
Corliss Engines,  
Concentrating Machinery.

FRASER & CHALMERS

have the best manufacturing facilities for making anything in the Perforated Metal line, Placer Grizzlies with Taper Holes, Stamp Mill Screens, Trommels, Coal Screens, &c. Screen Samples on Request.