

## Technical and Bibliographic Notes / Notes techniques et bibliographiques

The Institute has attempted to obtain the best original copy available for scanning. Features of this copy which may be bibliographically unique, which may alter any of the images in the reproduction, or which may significantly change the usual method of scanning are checked below.

L'Institut a numérisé le meilleur exemplaire qu'il lui a été possible de se procurer. Les détails de cet exemplaire qui sont peut-être uniques du point de vue bibliographique, qui peuvent modifier une image reproduite, ou qui peuvent exiger une modification dans la méthode normale de numérisation sont indiqués ci-dessous.

- |                                     |   |                                     |   |
|-------------------------------------|---|-------------------------------------|---|
| <input type="checkbox"/>            | Coloured covers /<br>Couverture de couleur  | <input type="checkbox"/>            | Coloured pages / Pages de couleur   |
| <input type="checkbox"/>            | Covers damaged /<br>Couverture endommagée   | <input type="checkbox"/>            | Pages damaged / Pages endommagées   |
| <input type="checkbox"/>            | Covers restored and/or laminated /<br>Couverture restaurée et/ou pelliculée   | <input type="checkbox"/>            | Pages restored and/or laminated /<br>Pages restaurées et/ou pelliculées   |
| <input type="checkbox"/>            | Cover title missing /<br>Le titre de couverture manque  | <input checked="" type="checkbox"/> | Pages discoloured, stained or foxed/<br>Pages décolorées, tachetées ou piquées  |
| <input type="checkbox"/>            | Coloured maps /<br>Cartes géographiques en couleur  | <input type="checkbox"/>            | Pages detached / Pages détachées  |
| <input type="checkbox"/>            | Coloured ink (i.e. other than blue or black) /<br>Encre de couleur (i.e. autre que bleue ou noire)  | <input checked="" type="checkbox"/> | Showthrough / Transparence  |
| <input type="checkbox"/>            | Coloured plates and/or illustrations /<br>Planches et/ou illustrations en couleur   | <input checked="" type="checkbox"/> | Quality of print varies /<br>Qualité inégale de l'impression  |
| <input checked="" type="checkbox"/> | Bound with other material /<br>Relié avec d'autres documents  | <input type="checkbox"/>            | Includes supplementary materials /<br>Comprend du matériel supplémentaire   |
| <input type="checkbox"/>            | Only edition available /<br>Seule édition disponible  | <input type="checkbox"/>            | Blank leaves added during restorations may<br>appear within the text. Whenever possible, these<br>have been omitted from scanning / Il se peut que<br>certaines pages blanches ajoutées lors d'une<br>restauration apparaissent dans le texte, mais,<br>lorsque cela était possible, ces pages n'ont pas<br>été numérisées. |
| <input type="checkbox"/>            | Tight binding may cause shadows or distortion<br>along interior margin / La reliure serrée peut<br>causer de l'ombre ou de la distorsion le long de la<br>marge intérieure. |                                     |   |
| <input checked="" type="checkbox"/> | Additional comments /<br>Commentaires supplémentaires:  |                                     | Continuous pagination.  |

# The Canadian Patent Office

## RECORD



Vol. XXV.—No. 9. SEPTEMBER 30th, 1897.

Price free by post in Canada and the United States, \$2.00.  
SINGLE NUMBERS, - - - 20 Cts

### NOTICE.

All solicitors, agents or attorneys who, in circulars or advertisements, or otherwise, refer to the Commissioner or Deputy Commissioner of Patents, or to any other official of the Patent Office, for evidence of their professional standing, do so without authority.

### INVENTIONS PATENTED.

NOTE.—Patents are granted for 18 years. The term of years for which the fee has been paid, is given after the date of the patent.

#### No. 57,250. Cyclometer and Register Mechanism. (Mécanisme de cyclomètre et registre.)

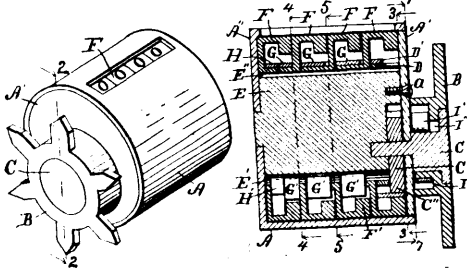

57250

Leo Jerod Burdick, Sturgis, Michigan, U.S.A., 1st September, 1897; 6 years. (Filed 16th June, 1897.)

*Claim.*—1st. The combination of a cylindrical case A, having a fixed head A<sup>2</sup>, and removable head A<sup>1</sup>; the shaft E, riveted to the fixed head A<sup>2</sup>, containing longitudinal grooves E<sup>1</sup> and E<sup>2</sup>, corresponding to the number of teeth or steps of the movement of the wheel; number wheels F, supported thereon, made of sheet metal having internal gear teeth F<sup>1</sup>, and a projecting hub F<sup>2</sup>, with slot F<sup>3</sup>, and projection P to the rear; a spring G with tooth G projecting into said slot to contact with the shaft and out to engage the gear teeth F<sup>1</sup> of the next higher; an internal gear wheel D, consisting of a ring with perforations revoluble on shaft E; an external gear wheel C<sup>1</sup> on shaft C, meshing with a hunting tooth gear with wheel D, carrying said wheel C<sup>1</sup>, and an actuating star wheel B revoluble on the shaft, with a ratchet for engaging the same; a spring D<sup>1</sup> surrounding the gear D, having an outwardly-projecting tooth D<sup>2</sup>; a projecting tooth C<sup>2</sup> on gear C<sup>1</sup>, to lift the gear tooth up and engage the first number wheel to actuate the same a single step, all co-acting substantially as described for the purpose specified. 2nd. In a cyclometer or register mechanism, the combination of a casing; a shaft containing longitudinal grooves corresponding to the steps of the movement, one of which grooves is shallow; number wheels containing internal gear teeth mounted revolubly on said shaft; a spring with an inwardly-projecting tooth to engage in the grooves of the shaft, and an outwardly-projecting tooth to engage the next number wheel when passing the shallow depression carried by each of the lower said number wheels; and means for actuating the lower number wheels, for the purpose specified. 3rd. In a

cyclometer or register mechanism, the combination of a shaft containing longitudinal, continuous cam-grooves; gear number wheels mounted thereon; a radially-movable tooth carried by each of the lower number wheels, and guided by the cam-grooves to engage the next higher number wheels at intervals of its rotation to operate the same, for the purpose specified. 4th. In a cyclometer or register mechanism, the combination of a fixed shaft E, containing longitudinal cam-grooves E<sup>1</sup>, sheet metal number wheels having internal gears and projecting hubs F<sup>2</sup>; a spring G on said hub with one end projecting within the hub and the other without, co-acting as specified. 5th. In a cyclometer or register mechanism, the combination of a fixed shaft containing longitudinal cam-grooves; number wheels mounted thereon containing internal gear teeth; a spring with an outwardly and an inwardly-projecting tooth carried by each of the lower number wheels in contact with said shaft to serve as a brake, and to actuate the next higher wheel of the series, for the purpose specified. 6th. In a cyclometer or register mechanism, the combination of a fixed shaft containing continuous, longitudinal cam-grooves; gear number wheels mounted thereon; a spring with a tooth thereon carried by each of the lower wheels to be actuated by the cam-grooves to engage at intervals of its rotation the next higher wheel, for the purpose specified. 7th. In a cyclometer or register mechanism, the combination of a fixed shaft with cams formed therein; gear number wheels mounted on said shaft; a movable tooth carried by each of the lower number wheels to be actuated by the cam of the shaft, to actuate at intervals of its rotation the next higher number wheel. 8th. In a cyclometer or register mechanism, the combination of a fixed shaft; number wheels carried by said shaft; an internal gear consisting of a perforated ring carried on said shaft; a spring embracing the same and covering one of the perforations, a tooth on said spring to engage the lowest number wheel normally out of engagement therewith; an external gear wheel carried on a pivot or shaft on the end of the main shaft meshing therewith, having a projecting tooth to raise the spring and cause the tooth to engage the number wheel at intervals of its rotation, for the purpose specified. 9th. In a cyclometer or register mechanism, the combination of an internal gear; an external gear, having projecting hunting tooth; a tooth on a suitable spring carried by the internal gear to be actuated by the projecting tooth at intervals of its rotation to actuate the number wheel, as specified. 10th. In a cyclometer or register mechanism, the combination of a series of number wheels, having internal gear teeth; a movable tooth carried by each of the lower number wheels; a shaft to support said number wheels, containing cam depressions therein of sufficient depth to allow the movable tooth on each lower wheel to pass the gear teeth upon the next higher number wheel, except at transferring points, where each said movable tooth is carried to engage with and actuate the number wheel adjacent thereto; and means for retaining the said movable teeth in contact with said shaft. 11th. In a cyclometer or registering mechanism, the combination of a series of geared number wheels; a movable tooth carried by each of the lower number of wheels; a cam-formed shaft to support said number wheels, and guide said movable teeth past the gear teeth of said number wheels; except at transferring points where said movable teeth engage with and actuate the number wheel's adjacent therewith, and means of retaining said movable teeth in contact with said cam-formed shaft. 12th. In a cyclometer or register mechanism, the combination of a series of geared number wheels; a movable tooth carried by each lower number wheel; a cam for each lower number wheel, containing depressions to guide the movable tooth thereof past the gear teeth of the next higher number, except at transferring points where said movable teeth engage and actuate the higher number of wheels adjacent thereto; means of retaining the movable teeth in contact with their respective cams, for the purpose specified. 13th. In a cyclometer or register mechanism,

the combination of a fixed shaft with cams formed therein; geared number wheels mounted on said shaft; a movable tooth carried by each of the lower number wheels; means of retaining each movable tooth in contact with the cams in said shaft, so that each tooth shall engage at intervals of the rotation of its number wheel the next higher wheel, so that the wheels can be placed on said shaft and easily removed without obstruction from the cams, for the purpose specified. 14th. In a cyclometer registering mechanism, the combination of a number wheel; a second wheel adjacent thereto, having suitable gear teeth; a movable tooth carried by said second wheel; a third gear wheel meshing with said second wheel, having a suitable projection to act on the movable tooth of said second wheel to actuate said number wheel, and means for actuating the third gear wheel, for the purpose specified.

**No. 57,251. Steam Engine Indicator.**  
(Indicateur de machines à vapeur.)

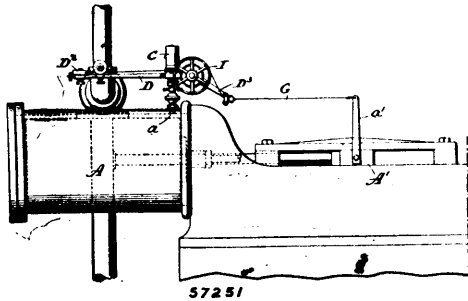

57251

Peter E. Apgar, Philadelphia, Pennsylvania, U.S.A., 1st September, 1897; 6 years. (Filed 20th July, 1897.)

*Claim.*—1st. An indicator for steam engines, comprising in combination with a pressure cylinder lever operated therefrom and a card cylinder, a frame provided at one end with a wheel acted upon by a spring, and having a grooved pulley, a cord adapted to the grooved periphery of said wheel, an adjustable arm secured to said frame and provided with pulleys for guiding the cord, a second cord secured at one end to the hub of said wheel, a spring actuated pulley to which the opposite end of said cord is secured the same being adjustably secured to said frame, a third cord detachably secured at one end to the latter cord and guided by an adjustable pulley mounted upon the end of the frame, the said cord being secured at the other end to the spring actuated card cylinder, substantially as specified. 2nd. An indicator for steam engines, comprising in combination with a pressure cylinder and card cylinder, a frame provided with an adjustable arm, a cord guided thereby leading to the crosshead or other working parts of the engine, a spring actuated wheel pivoted to said frame, and having a grooved periphery for taking up the slack of said cord, a hub upon said wheel, a collar upon said hub, a cord secured to the same, a spring actuated pulley adjustably secured to the frame for taking up the slack of the last mentioned cord, a loop in said cord, a ring hung to said loop, a cord leading from the card cylinder and provided with a hook to engage the said ring, a pulley mounted upon the end of the frame and guiding the last mentioned cord, stop mechanism mounted upon the frame for locking the latter cord after it has travelled to the full extent of its movement in one direction, said stop mechanism being interposed between the card cylinder and pulley mounted upon the end of the frame, substantially as specified. 3rd. An indicator for steam engines comprising in combination with a pressure cylinder and card cylinder, a frame detachably secured to the card cylinder and provided at one end with an adjustable arm having pulleys universally adjustable in the end thereof, a cord adapted thereto, a wheel acted upon by a spring, mounted in a drum or casing in the frame, said wheel having a grooved periphery receiving said cord, a drum or casing secured to or forming part of the frame, a hub projecting out from said wheel, a cord adapted to said hub, a spring actuated pulley adjustably secured to the frame near the opposite end thereof, receiving the last mentioned cord, a pulley mounted upon a sliding block guided in the end of the frame, a thumb screw mounted upon the stem in said block and capable of adjusting the position of said pulley and a cord carried by said pulley, substantially as specified. 4th. A reducing gear for steam engine indicators, comprising an operating cord, a spring actuated wheel acting upon the same, an intermediate cord adapted to a reduced portion of said wheel, a spring actuated pulley, adapted to the latter cord an indicator cord adapted to the last named pulley and to a loop in the intermediate cord, and acting upon the card cylinder, substantially as specified. 5th. A reducing gear for steam engine indicators, comprising an operating cord, a wheel rotatable in one direction by said cord, spring means for operating the said wheel in the opposite direction, an intermediate cord secured to the hub of said wheel a pulley acted upon in one direction by said intermediate cord; spring means for operating said pulley in the opposite direction, an indicator cord secured to the intermediate cord and operating the card drum and mechanism for acting upon the indicator cord after the same has travelled to the full extent of its motion in one direction,

substantially as specified. 6th. A stop motion for steam engine indicators, comprising an eccentric or cam and a block arranged upon opposite sides of the cord and a spring acting upon said eccentric or cam and adapted to lock said cord.

**No. 57,252. Pot Cover Drainer.**  
(Couvercle-égouttoir pour pots.)

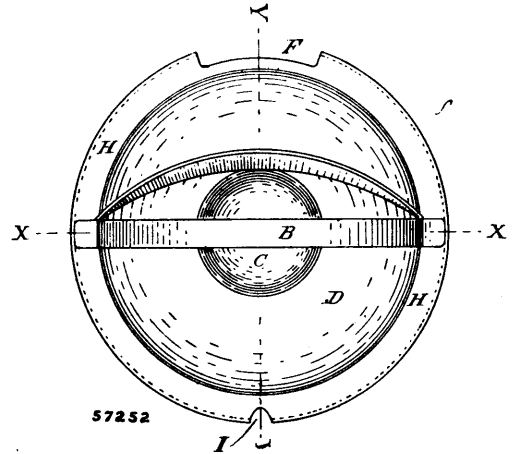

57252

Thomas Joseph MacLaughlin and John Beverly MacLaughlin, both of Ottawa, Ontario, Canada, 1st September, 1897; 6 years. (Filed 26th July, 1897.)

*Claim.*—As an article of manufacture a pot cover comprising a handle B, steam shield A, convex top D, having concavity C, and rim H, and flange G, said rim and flange cut away at F, I, all formed, arranged and combined as and for the purposes hereinbefore set forth.

**No. 57,253. Car Coupling.** (Attelage de chars.)

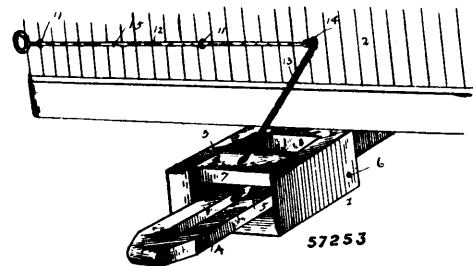

57253

Philip Schreiber, Alma, Kansas, U.S.A., 1st September, 1897; 6 years. (Filed 28th July, 1897.)

*Claim.*—1st. In a car coupling, the combination of a draw-head, a fixed catch mounted on the bottom of the draw-head and adapted to be engaged by a link, and upwardly-swinging link-holder pivotally mounted between the sides of the draw-head and comprising longitudinally-disposed sides, a bottom connecting the sides and arranged in rear of the fixed catch, and a top extending over the catch and in advance of the same to confine a link into engagement therewith, and having its rear portion inclining downward toward the bottom of the link-holder, to form a pocket or recess to receive and engage a link, substantially as described. 2nd. In a car coupling, the combination of a draw-head, provided at its bottom with an upwardly-extending rigid catch and having a recess in rear of the catch and an upwardly-swinging link-holder pivotally mounted between the sides of the draw-head and comprising sides, a top extending over the catch and in rear of the same and a bottom fitting in the recess of the bottom of the draw-head having its upper face flush with the upper face of the front portion of the same and having its front edge bevelled and provided with a central recess, substantially as described. 3rd. In a car coupling, the combination with a car, of a draw-head provided with a link engaging and releasing devices, a guide mounted on the car and located above the draw-head, a chain connecting to and extending upward from the link releasing device and passing through the said guide, and a slide operating-rod mounted in suitable guides of the car provided with a shoulder for engaging one of such guides, and connected with said chain, substantially as described.

**No. 57,254. Window Sash Fastener.** (Arrêlé-croisé.)

Samuel Densmore and James Dolan, both of Vanderbilt, Pennsylvania, U.S.A., 1st September, 1897; 6 years. (Filed 2nd August, 1897.)

*Claim.*—1st. In a sash fastener, the combination with the eyes secured to the upper and lower sash, integral pins extending

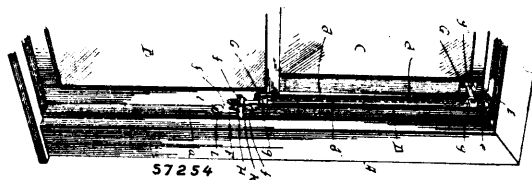

horizontally into the apertures of said eyes, of the rod D, having a series of notches, a longitudinal groove adjacent to the said notches, the eyes designed to work on said rod, and means for rotating the same whereby the eyes may be allowed to slide or be locked to said rod, substantially as shown and described. 2nd. In a sash fastener, the combination with a notched rod mounted as described, of the casting F of the lever pivoted near the lower end of said rod and a handle H pivoted to said lever, an integral portion h of the said handle adapted to rest in a recess in the casting, and a spring h', bearing on the lever and handle over the pivotal connection between the latter, substantially as shown and described. 3rd. In a window frame, the combination of the eye, the locking-rod passing through the same, the socket journaling the upper end of the rod, the slotted bracket journaling the lower part thereof, and the eccentric engaging the bracket, substantially as specified.

**No. 57,255. Smoke Consumer.**

(Appareil à consumer la fumée.)

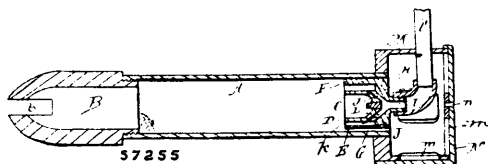

Charles C. Bruckner, Chicago, Illinois, U.S.A., 1st September, 1897; 6 years. (Filed 4th August, 1897.)

*Claim.*—1st. In a smoke-consumer, the combination with a mixing-tube, a superheating-nozzle on one end of said tube, of a steam nozzle in the other end of said tube, comprising an outer tube arranged in the mixing-tube to provide a space between said tube and the mixing-tube, an inner tube leaving a space between itself and the outer tube, a bridge-wall provided with a hollow extension and ports leading from said hollow extension to the space between the inner and outer tubes, and a steam-pipe communicating with said extension, substantially as described. 2nd. In a smoke-consumer, the combination with a mixing-tube, having a superheating-nozzle on one end thereof, of a steam nozzle, adapted to be arranged in the other end of said mixing-tube, and comprising a bridge-wall having a hollow extension, an inner tube and an outer tube connected to said bridge-wall and having a space between them, ports leading from the hollow extension to said space between the tubes, a steam-pipe communicating with said hollow extension, and ribs on the outer side of the outer tube adapted to fit snugly within the end of the mixing-tube, and thereby provide a space between the outer tube and the mixing-tube, substantially as described. 3rd. In a smoke-consumer, the combination with a mixing-tube, having a superheating-nozzle on one end thereof, of a steam-nozzle secured in the other end of said tube, and consisting of an outer tube, the ribs on said outer tube adapted to fit between said tube and the mixing-tube thereby providing a space between said tubes, an inner tube arranged within the outer tube and providing space between said inner and outer tubes, a bridge-wall, a hollow extension on said bridge-wall, ports in the bridge-wall leading from the hollow extension and opening in the space between the inner and outer tubes and on opposite sides of the nozzle, a steam-pipe communicating with said hollow extension, a plug closing the inner end of said extension, and adapted to be adjusted to control the amount of steam passing into the ports, and a perforated cap removably secured on the outer end of said mixing-tube, substantially as described. 4th. In a smoke-consumer, the combination with a mixing-tube, a superheating-nozzle on one end of said tube, a steam-nozzle fitted in the other end of that tube and comprising an outer tube, an inner tube, a bridge-wall having a hollow extension and ports leading from said extension to a space between the tubes, a steam-pipe communicating with said extension, of a cap arranged on the tube and over the steam-nozzle and provided with openings therein and a damper plate pivotally secured on the cap and provided with openings to register with the openings in the cap, substantially as described. 5th. In a smoke-consumer, the combination with a mixing-tube, a superheating-nozzle on one end thereof, of a steam-nozzle in the other end of the tube provided with a hollow extension, an elbow secured on the extension, a steam-pipe on the elbow, a cap provided with top and side openings and secured to the tube, and a damper-plate pivotally secured on the cap and provided with openings to register with the openings in the cap, substantially as described.

**No. 57,256. Stop-Cock Box.** (Boîte de robinet ordinaire.)

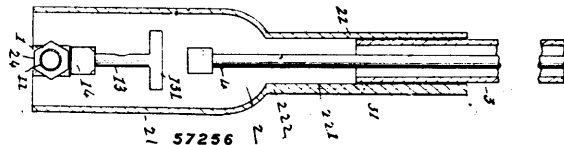

Henry Noel Chauvin, Montreal, Quebec, Canada, 1st September, 1897; 6 years. (Filed 5th August, 1897.)

*Claim.*—1st. In a stop-cock box the combination of an extended enlarged lower portion, a reduced upper portion grooved to hold the projection of a telescope pipe. 2nd. In a stop-cock box the combination of an outer case with its upper half reduced to fit over a telescope pipe, the lower enlarged portion containing a tee-handle riveted to the stop-cock, to be operated by a forked key-rod. 3rd. In a stop-cock box, the combination of a lower section in which the upper half is reduced in size, a groove therein, a stop at lower end of groove, a telescope pipe with a projection to fit groove, and a lower enlarged half to cover stop-cock and attachments and supply free play to the same.

**No. 57,257. Detachable Heel for Boots and Shoes.**

(Talon mobile pour chaussures.)

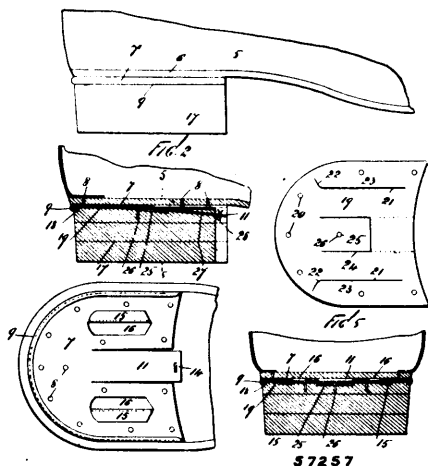

Alexander Maebert, Jersey, New Jersey, U.S.A., 1st September, 1897; 6 years. (Filed 5th August, 1897.)

*Claim.*—1st. A boot or shoe provided with a heel plate which is secured thereto and provided at the sides and rear portion thereof with a downwardly and inwardly directed flange or rim, and a centre plate secured to the bottom thereof, and provided with a forwardly directed extension, and a detachable heel which is provided around the sides and rear portion thereof with a groove, which is adapted to receive said flange or rim, and centrally thereof with a cavity or recess which communicates with a passage or opening formed in said heel, and extending forwardly, and through which the forwardly directed extension of said centre plate passes, substantially as shown and described. 2nd. A boot or shoe, provided with a heel plate which is secured thereto and provided at the sides and rear portion thereof with a downwardly and inwardly directed flange or rim, and a centre plate secured to the bottom thereof, and provided with a forwardly directed extension, and a detachable heel which is provided around the sides and rear portion thereof with a groove, which is adapted to receive said flange or rim, and centrally thereof with a cavity or recess which communicates with a passage or opening formed in said heel, and extending forwardly, and through which the forwardly directed extension of said centre plate passes, said heel plate being also provided at each side of the centre plate with longitudinal flanges or wings, and said heel with corresponding slots or grooves, substantially as shown and described. 3rd. A boot or shoe, provided with a heel plate as 7, constructed as herein described, and a detachable heel as 17, said heel being provided with a centre plate which is provided with a forwardly directed extension, and said heel being provided centrally thereof with a cavity or recess which communicates with a forwardly directed passage or opening formed in said heel, and through which the extension of said centre plate passes, substantially as shown and described.

**No. 57,258. Cow-Milking Machine.**

(Machine à traire les vaches.)

Herbert James Cumming, 71 Cathedral Square, New Zealand, 1st September, 1897; 6 years. (Filed 7th August, 1897.)

*Claim.*—1st. The improved method of producing pulsation of the flexible lining of the teat cups of milking machines, consisting in



connecting the annular space between said flexible lining and the rigid outer tube of the teat cup, by pipes to the main vacuum tank

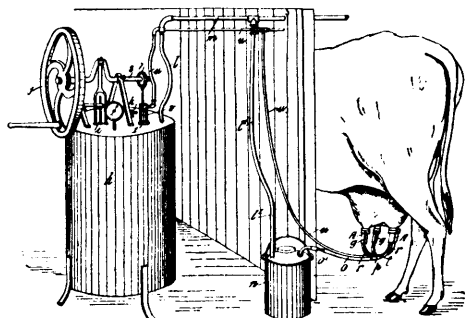

57258

of the milking machine, valve mechanism being employed, whereby communication is alternately established between said tank, and the annular space in the teat cup, and between said annular space and the atmosphere, substantially as specified. 2nd. A pulsating teat cup constructed of a flexible rubber tube *a* between and connected to the non-flexible tubes *b, d*, a non-flexible covering ring *c*, forming an outer casing for tube *a*, and an air-pipe *g*, communicating with the main air pipe of the machine substantially as and for the purposes herein described and illustrated in the accompanying drawings. 3rd. The combination in apparatus for producing in the teat cups of milking machines of a valve for alternately opening communication between the vacuum tank and the annular space of the teat cup and between such annular space and the atmosphere, such valve being operated by an eccentric upon the crank shaft of the air pump, substantially as herein specified and illustrated. 4th. In combination the air pump crank shaft 8, eccentric 7, strap and connecting rod 9, piston valve 6, casing 1, having ports 3, 5, opening into pipe 4, the tube *u*, and teat cup *A*, substantially as and for the purposes herein described and illustrated in the accompanying drawings. 5th. The combination in apparatus for producing pulsation in the teat cups of milking machines, of the air branch piece *t*, arranged above and connected to the milk pipe branch piece *p*, the several branches upon the branch pieces *t* and *p* being arranged with their openings in one plane, substantially as and for the purposes herein specified and illustrated. 6th. The combination and arrangement of parts comprising my improved apparatus for producing pulsation in the teat cups of milking machines, the whole constructed, arranged, and operating, substantially as and for the purposes herein described and illustrated in the accompanying drawings.

**No. 57,259. Convertible Couch. (Canapé convertible.)**

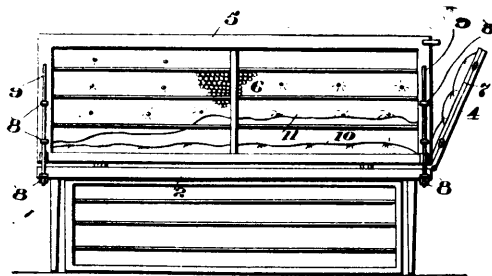

57259

Jane Geddes, Rutland, Vermont, U.S.A., 1st September, 1897; 6 years. (Filed 7th August, 1897.)

*Claim.*—1st. In a couch, the combination with the top having supporting legs and an inclined head section, a spring-mattress attached to the couch, a frame hinged to one side of the top and provided with a spring-mattress, sliding bars carried by the hinged section and adapted to engage the top of the couch, and a head section hinged to the main head section so as to fold thereon, the parts being constructed and organized, substantially as shown and described. 2nd. A convertible couch, comprising a stationary top supported upon legs, and spring-mattress or bed-bottom connected to the top, and a stationary head section inclined from one end of said top, together with a frame hinged to one side of the top and having a spring-mattress or bed-bottom, a supplemental head section pivoted to the stationary head section, bolts in sliding engagement with the hinged section, and additional supports for the hinged section, to provide a piece of furniture which can be readily changed from a couch to a bed or vice versa, substantially as shown and described. 3rd. In a convertible couch, the combination with the top supported by legs or equivalent devices, a spring-mattress or bed-bottom attached to the top, an inclined head section rigidly attached to one end of the top, a frame hinged to one side of the top and having sliding bars in engagement therewith, a supple-

mental head section hinged to the main head section, means for supporting the hinged frame when extended, and bedding or cushions made up of two sections hinged to each other and adapted to rest upon the sections, the parts being constructed and susceptible of arrangement, substantially as shown and described. 4th. In a convertible couch, the combination with the top supported by legs, a spring-mattress or bed-bottom attached to the top, an inclined head section rigidly attached to one end of the top, a frame hinged to one side of the top and having sliding bars in engagement therewith, a supplemental head section hinged to the main head section, means for supporting the hinged frame when extended, and bedding or cushions made up of two sections hinged to each other and adapted to rest upon the springs of the sections, together with a frame or drawer in sliding engagement with the main section of the couch to receive the bed clothes, the parts being constructed and organized substantially as shown and described.

**No. 57,260. Commode. (Commode.)**

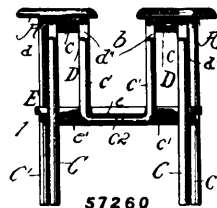

57260

Bishop Adams Hall, Pine Bluff, Arkansas, U.S.A., 1st September, 1897; 6 years. (Filed 9th August, 1897.)

*Claim.*—1st. In a commode, the combination of a seat having the usual large opening through it and a passage extending out from one end of said opening and dividing the seat at that end, two pairs of legs, each pair connected together by means of pivots extending inward, one from the upper end of each leg, a pair of downwardly-extending hangers, one hanger connected with the inner end of each pivot, and a cross-piece connecting the lower ends of the hangers, means fastening said legs to said seat, a shelf supported by said hangers and keeping said legs spaced apart, and means limiting the outward movement of the legs substantially as described. 2nd. In a commode, the combination of a seat divided longitudinally into two parts completely separated by the usual large opening and two passages leading out from opposite ends of said opening, two pairs of legs, means fastening each pair of legs to both parts of said seat, and means passing across below said seat and connecting the legs of each pair together, and holding the parts of said seat apart and in position, substantially as described. 3rd. In a commode, the combination of a divided seat, longitudinally into two parts, completely separated by the usual large opening, and two passages extending out from the opposite ends of said opening, two pairs of legs, means hinging each pair of legs to both parts of the seat, means passing across below the seat and connecting each pair of legs together and holding the parts of the seat apart and in position, means limiting the spreading of the two pairs of legs away from each other and means keeping them spaced apart substantially as described. 4th. In a commode, a divided seat composed of parts *A, A'*, two pairs of legs, means connecting the legs of each pair together, means hinging each pair of legs to both parts of the seat, means limiting the spreading of the legs and a shelf keeping the legs spaced apart substantially as described. 5th. In a commode, a divided seat composed of parts *A and A'*, two pairs of legs, means connecting the legs of each pair together, means hinging each pair of legs to both parts of the seat, means limiting the spreading of the legs, a shelf keeping said legs spread apart and means adjustably securing the shelf in position.

**No. 57,261. Fire Lighter. (Allumoir.)**

Frederick Meyers, Emden, Illinois, U.S.A., 1st September, 1897; 6 years. (Filed 9th August, 1897.)

*Claim.*—1st. In a fire-lighter, a frame or support adjustably mounted upon a standard, a lever pivoted on the frame and turned up at one end, such upturned end having a notch cut therein, the opposite end of said lever being free, but adapted to be operated by suitable means for the purpose set forth, an arm or trigger *H* pivoted at one end to the frame or support, its free end engaging the aforesaid lever by its notch, a spring secured at one end to the frame or support, a pin carried on the opposite end of said spring and engaging the arm or trigger *H*, a revoluble rod having bearings in the said frame or support, an arm bent at right angles to said rod to engage the pin in said trigger, a coil-spring surrounding the said rod for operating same, a friction device on the free end of said rod, a match-holder secured to the frame or support and adapted to hold a match in contact with the friction device and a torch adapted to be lighted by said match, substantially as shown and described. 2nd. In automatic fire-lighters, a frame or support mounted on a standard, a clock mounted in said frame or support, a lever pivoted on the frame and turned up at one of its ends, such upturned end having

a notch cut therein, the opposite end of said lever being free but adapted to be operated by said clock for the purposes set forth, an

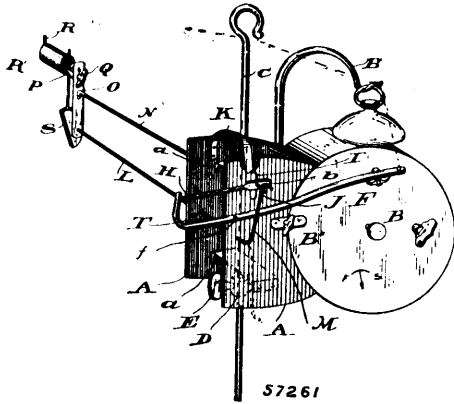

arm or trigger H pivoted at one end to the frame or support, its free end engaging the aforesaid lever by its notch, a spring secured to one end to the frame or support, a pin carried on the opposite end of said spring and engaging the arm or trigger H, a revoluble rod having bearings in the frame or support, an arm bent at right angles to said rod to engage the pin in said trigger H, a coil-spring surrounding the said rod for operating same, a friction device on the free end of said rod, a match holder secured to the frame or support and adapted to hold a match in contact with the friction device, and a torch adapted to be lighted by said match, substantially as shown and described.

**No. 57,262. Car Coupler. (Attache de chars.)**

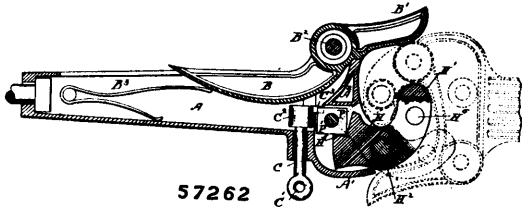

William Everett Pearson, Boston, Massachusetts, U.S.A., 1st September, 1897; 6 years. (Filed 9th August, 1897.)

*Claim.*—In a car coupling, a swing hooking jaw having a shoulder at its rear end adapted to engage with a vertically moving locking block so confined as to have no motion except in a vertical line, and a rotatable shaft having a lever arm adjusted to engage with and raise the said locking block, substantially as and for the purpose set forth.

**No. 57,263. Apparatus for Utilizing Exhaust Steam. (Appareil pour utiliser la vapeur consommée.)**

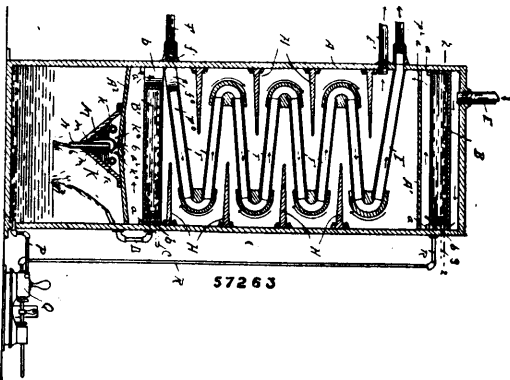

Herman Ten Winkel, Denver, Colorado, U.S.A., 1st September, 1897; 6 years. (Filed 9th August, 1897.)

*Claim.*—1st. In an apparatus for utilizing exhaust steam, the combination with an inclosing tank or casing having a superheating chamber in its upper portion with an inlet pipe for exhaust steam leading thereto, and an outlet for the steam at one end of the bottom thereof, a larger condensing chamber beneath said superheating chamber, with an inwardly inclined bottom thereto, and a receiving

tank or reservoir beneath said condensing chamber, of a closed tank in said superheating chamber having a passage at one end for the circulation of steam around said tank, a zigzag air flue in said condensing chamber having air inlet and outlet pipes leading outside of the inclosing tank, flat horizontal deflectors fixed to the sides of said inclosing tank and projecting inward between the sections of said air flue, a closed feed water tank in the lower portion of said condensing chamber having passages around its ends for the circulation of steam, an oil separator beneath the perforations in the bottom of said condensing chamber, an inlet pipe leading to said feed water tank into said receiving reservoir, means for conveying the water from said receiving tank to the tank in said superheating chamber, and an outlet pipe from said latter tank, substantially as described. 2nd. In an apparatus for utilizing exhaust steam, the combination with an inclosing tank or casing having a superheating chamber in its upper portion with an inlet pipe for exhaust steam leading thereto, and an outlet for the steam at one end of the bottom thereof, a larger condensing chamber beneath said superheating chamber, with inwardly inclined perforated bottom thereto, and a receiving tank or reservoir beneath said condensing chamber, of a closed tank in said superheating chamber, having a passage at one end for the circulation of steam around said tank, a zigzag air flue composed of flat hollow sections connected together by suitable unions in said condensing chamber and having air inlet and outlet pipes leading outside from said inclosing tank, horizontal deflectors fixed to the sides of the inclosing tank and projecting inward between the sections of said air flue, a closed feed water tank in the lower portion of said condensing chamber having passages around its ends for the circulation of steam, an oil separator mounted beneath the perforations in the bottom of said condensing chamber and consisting of a trough having a water outlet extending upward in said trough a hood covering said water outlet and having perforations near the base thereof, and an overflow pipe in the upper portion of said trough for the oil, an inlet pipe to said feed water tank, an outlet pipe from said feed water tank leading into said receiving reservoir, means for conveying the water from said receiving tank to the tank in the superheating chamber, and an outlet pipe from said latter tank, substantially as described. 3rd. In an apparatus for utilizing exhaust steam, the combination with an inclosing tank or casing having a superheating chamber in its upper portion with an inlet pipe for exhaust steam leading thereto and an outlet for the steam at one end of the bottom thereof, a larger condensing chamber beneath said superheating chamber, with an inwardly inclined perforated bottom thereto, and a receiving tank or reservoir beneath said condensing chamber, of a closed tank in said superheating chamber having a passage at one end for the circulation of steam around said tank, a zigzag air flue in said condensing chamber having air inlet and outlet pipes leading outside said inclosing tank horizontal deflectors fixed to the sides of the inclosing tank and projecting inward between the sections of said air flue, a closed feed water tank in the lower portion of said condensing chamber having passages around its ends thereof, an oil separator mounted beneath the perforations in the bottom of said condensing chamber and consisting of a trough having a water outlet extending upward in said trough a hood covering said water outlet and having perforations near the base thereof, and an overflow pipe in the upper portion of said trough for the oil, an inlet pipe to feed said water tank, an outlet pipe from said feed water tank leading into said receiving reservoir, means for conveying the water from said tank to the tank in the superheating chamber, and an outlet pipe from said water tank, substantially as described.

**No. 57,264. Railway Switch. (Aiguille de chemin de fer.)**

Ethelbert Leopold Karn, Denver, Colorado, U.S.A., 1st September, 1897; 6 years. (Filed 9th August, 1897.)

*Claim.*—1st. The combination with a track provided with fixed points, of a main frame adapted to swing between said points, and pivoted switch-arms mounted on said frame, and adapted to form a continuous guide into the siding or along the main track, according to the position of the main frame, substantially as and for the purpose described. 2nd. The combination with a track provided with fixed points, of a main frame adapted to swing between said points, a cam for moving said frame, and pivoted swing-arms mounted on

said frame and adapted to form a continuous guide into the siding or along the track, according to the position of the main frame,

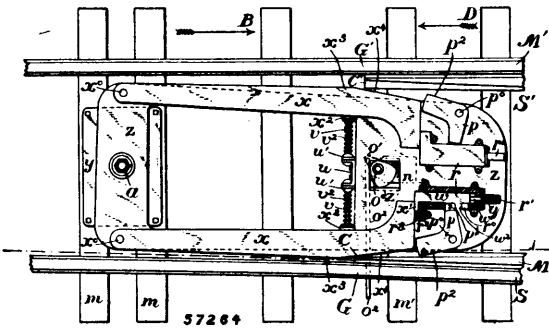

substantially as described. 3rd. The combination with a track provided with fixed points, of a main frame adapted to swing between said points, pivoted switch-arms mounted on said frame, and adapted to form a continuous guide into the siding or along the main track, according to the position of the main frame, and means for locking the said switch-arms when a train passes in one direction, and for releasing said pivoted arms when a train comes in the opposite direction, substantially as described. 4th. The combination with a track provided with fixed points, pivoted switch-arms mounted on said frame, and adapted to form a continuous guide into the siding or along the main track, according to the position of the main frame, and springs normally pressing said arms outward, substantially as and for the purpose described. 5th. The combination with a track provided with fixed points, of a main frame adapted to swing between said points, a cam for moving said frame, pivoted switch-arms mounted on said frame and adapted to form a continuous guide into the siding or along the track, according to the position of the main frame, and springs normally pressing said arms outward, substantially as described. 6th. The combination with a track provided with fixed points, of a main frame adapted to swing between said points, pivoted switch-arms mounted on said frame and adapted to form a continuous guide into the siding or along the main track, according to the position of the main frame, springs normally pressing said arms outward, and means for locking the said switch-arms when a train passes in one direction, and for releasing said pivoted arms when the train comes in the opposite direction, substantially as described. 7th. The combination with a track provided with fixed points, of a main frame adapted to swing between said points, with pivoted switch-arms mounted on said frame and adapted to form a continuous guide into the siding or along the main track, according to the position of the main frame, means for locking the said switch-arms when a train passes in one direction, and for releasing the said switch-arm when a train passes in the opposite direction, and a cam for swinging said frame on its pivot, with means for operating said cam, substantially as described. 8th. The combination with a track provided with fixed points, of a pivoted main frame adapted to swing between said points, a cam for moving said frame in either direction, and means for operating said cam, pivoted switch-arms having double inclined faces mounted on said frame and adapted to form a continuous guide into the siding or along the track, according to the position of the main frame, with means for locking said switch-arms against the lateral pressure of car-wheels coming from one direction, and for releasing said switch-arms by the lateral pressure of car-wheels coming from the opposite direction, substantially as described. 9th. The combination with a track provided with fixed points, of a swinging frame, pivoted switch-arms carried by said frame and adapted to form a continuous guide into the siding or along the main track, according to the position in which the switch is thrown, a socket-plate mounted on said frame between said switch-arms, rods with ball-heads pivoted in said socket plate and entering guides in said switch-arms, coil-springs inclosing said rods and normally pressing said switch-arms outward, and means for locking said switch-arms against the pressure due to a train coming from one direction, and for releasing them by means of the pressure of a train coming from the opposite direction, substantially as described. 10th. The combination with a track provided with fixed points, of a frame pivoted between the tracks, pivoted switch-arms mounted on said frame and adapted to form a continuous guide into the siding or along the main track, according to the position of the main frame, springs normally pressing said switch-arms outward, spring-operated latches adapted to lock said switch-arm, and levers adapted to be struck by the wheels of the car, and to release said latches, substantially as described. 11th. The combination with a track provided with fixed points, of a main frame adapted to swing between said points, a cam for moving said frame, pivoted switch-arms mounted on said frame and adapted to form a continuous guide into the siding or along the track, according to the position of the main frame, springs normally pressing said switch-arms outward, spring-operated latches adapted to lock said switch-arm, and levers adapted to be struck by the wheels of a car, and to release said latches, substantially as described. 12th. The combination with a track provided with fixed points, of a main

frame adapted to swing between said points with pivoted switch-arms mounted on said frame and adapted to form a continuous guide into the siding or along the main track, according to the position of the main frame, springs normally pressing said switch-arms outward, latches for locking the said switch-arms, and bell-crank levers adapted to hold said latches when a train passes in one direction, and to release one of said latch-arms when a train passes in the opposite direction, substantially as described. 13th. The combination with a track provided with fixed points, of a pivoted frame adapted to swing between said points, cam mechanism for swinging said frame about its pivot, pivoted switch-arms mounted on said frame and adapted to form a continuous guide into the siding or along the main track, according to the position of the said frame, springs normally pressing said switch-arms outward, means for limiting the outward travel of said switch-arms, means for locking said switch-arms when a train passes in one direction, and means for releasing one of said switch-arms when the train passes in the opposite direction, substantially as described. 14th. The combination with a track provided with fixed points, of a pivoted frame adapted to swing between said points, a cam for moving said frame in either direction, and means for operating said cam, pivoted switch-arms having double inclined faces mounted on said frame and adapted to form a continuous guide into the siding or along the track, according to the position of the main frame, springs normally pressing said switch-arms outward, with means for locking said switch-arms against lateral pressure of car-wheels coming from one direction, and for releasing one of said switch-arms by the lateral pressure of car-wheels coming from the opposite direction, substantially as described. 15th. The combination with a track provided with fixed points, of a swinging frame, pivoted switch-arms carried by said frame and adapted to form a continuous guide into the siding or along the main track, according to the position in which the switch is thrown, springs normally pressing said switch-arms outward, a socket-plate mounted on said frame between said switch-arms, rods with ball-heads pivoted in said socket-plate, and entering guides in said switch-arms, coil springs inclosing said rods and normally pressing said switch-arms outward, and means for locking said switch-arms against the pressure due to a train coming from one direction, and for releasing them by means of the pressure of a train coming from the opposite direction, substantially as described.

No. 57,265. Railway Switch. (Aiguille de chemin de fer.)

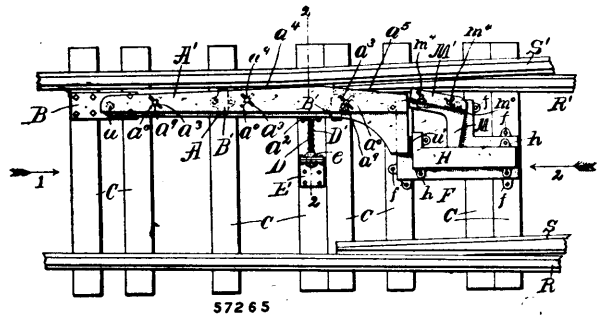

Ethelbert Leopold Karn, Denver, Colorado, U.S.A., 1st September, 1897; 6 years. (Filed 9th August, 1897.)

Claim.—1st. The combination with the fixed main and siding rails, of a pivoted switch arm, a spring normally pressing the same outward, a stop limiting the outward travel of said switch arm, and means for locking the switch arm against the pressure of wheels coming from one direction and for releasing the same by means of the pressure of wheels, coming from the opposite direction, substantially as described. 2nd. The combination with the fixed main and siding rails, of a pivoted switch arm, a ball headed bar passing through a guide in said switch arm, a socket plate holding the ball head of said bar, a spring interposed between said socket plate and said switch arm and normally tending to press said switch arm outward, a stop limiting the outward travel of said switch arm and means for locking said switch arm against the pressure of wheels coming from one direction, and for releasing the same by means of the pressure of wheels coming from the opposite direction, substantially as described. 3rd. The combination with the fixed main and siding rails, of a pivoted switch arm, having inclined slots therein, a wear plate mounted over said switch arm and having inclined slots crossing the slots in said switch arm, bolts passing through both of said slots and holding said wear plate on said switch arm, and means for locking the said switch arm against the pressure of wheels coming from one direction, and for releasing the same by means of the pressure of wheels coming from the opposite direction, substantially as described. 4th. In an apparatus of the character described, the combination with a switch arm having inclined slots therein, of a wear plate, mounted over said switch arm and having inclined slots crossing the slots in said switch arm, with bolts passing through both of said slots and holding said wear plates on said switch arm, substantially as described. 5th. The combination with the fixed main and siding rails, of a pivoted switch arm, a spring normally pressing the same outward, a stop limiting the out-

ward travel of said switch arm, a spring operated latch adapted to lock said switch arm in position and a bell crank lever adapted to be struck by the wheels of an approaching train and to withdraw said latch and release said switch arm, substantially as described. 6th. The combination with the fixed main and siding rails, of a pivoted switch arm, a ball headed bar passing through a guide in said switch arm, a socket plate holding the ball head of said bar, a spring interposed between said socket plate and said switch arm and normally tending to press said switch arm outward, a stop limiting the outward travel of said switch arm, a spring operated latch adapted to limit the inward travel of said switch arm, and a bell-crank lever adapted to be struck by the wheels of an approaching train and to withdraw said latch and release said switch arm, substantially as described. 7th. The combination with the fixed main and siding rails, of a pivoted switch arm, a spring normally pressing the same outward, a stop limiting the outward travel of said switch arm, a spring operated latch adapted to limit the inward travel of said switch arm, a bell-crank lever having one arm adapted to engage said latch and having the other arm provided with inclined slots, a wear plate having slots crossing the inclined slots in said bell-crank lever and bolts adjustably connecting said wear plate with said bell-crank lever, the said wear plate being adapted to be struck by the wheels of passing trains, substantially as and for the purposes described.

**No. 57,266. Window Frame. (Cadre de fenêtre.)**

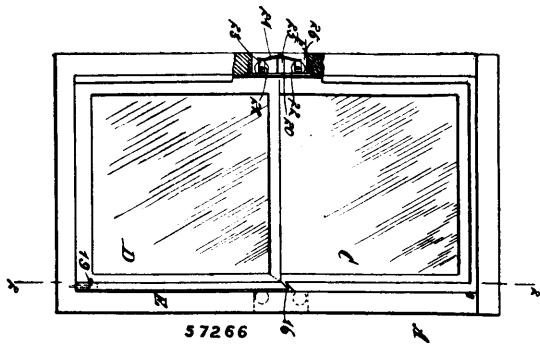

Alexander Erklin, New York, State of New York, U.S.A., 1st September, 1897; 6 years. (Filed 9th August, 1897.)

*Claim.*—1st. The combination, with a window frame, of tension devices adapted for engagement with the sashes, the said devices being located in recesses produced in the back wall of the sash grooves of the frame, each device comprising an apertured face plate having a central support on its rear face, a spring secured to said support at the centre of its length, and friction rollers attached to the end portions of the spring, a portion of their peripheral surfaces extending through an opening in the face plate, as and for the purpose specified. 2nd. A tension device for windows, consisting of a face plate having an opening near each end and provided with a post projecting from its rear face, a spring secured at the centre of its length to the post, brackets on the ends of the spring, and rollers mounted in the brackets and projecting into the openings of the face plate, substantially as herein shown and described.

**No. 57,267. Packing for Journal Boxes. (Garniture de coussinet de tourillon.)**

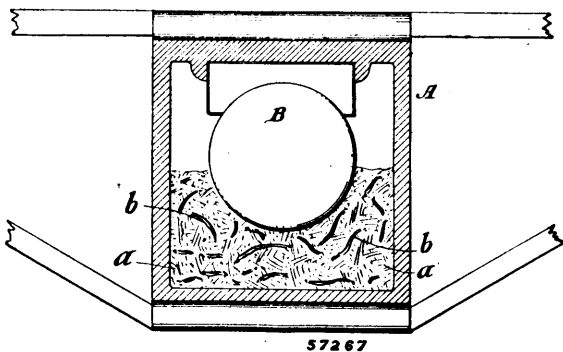

The Franklin Manufacturing Co., assignee of Edward B. Johnston, both of Franklin, Pennsylvania, U.S.A., 1st September, 1897; 6 years. (Filed 10th August, 1897.)

*Claim.*—1st. A packing for journal boxes comprising a conductor for the lubricating oil, non-absorbent and non-combustible in character, having intermingled therewith an elastic, fibrous material, said packing being retained in a fluffy and non-compressed state, for the purposes set forth. 2nd. A packing for journal boxes,

comprising a conductor for the lubricating oil, non-absorbent and non-combustible in character, having intermingled therewith an elastic, fibrous, non-absorbent material, said packing being retained in a fluffy and non-compressed state, for the purpose set forth. 3rd. A packing for journal boxes, comprising a conductor for the lubricating oil, fibrous, non-absorbent and non-combustible in character, having intermingled therewith an elastic, fibrous, non-absorbent material, said packing being retained in a fluffy and non-compressed state, for the purpose set forth. 4th. A packing for journal boxes, comprising elastic fibre and asbestos fibre, both said fibres being intermingled and retained in a fluffy and non-compressed state, for the purpose set forth. 5th. A packing for journal boxes, comprising bamboo fibre and asbestos fibre, both said fibres being intermingled and retained in a fluffy and non-compressed state.

**No. 57,268. Diamond Car Drill. (Foret.)**

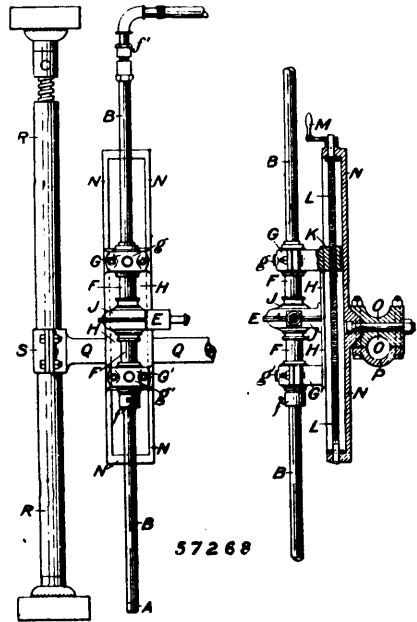

Henry Low Webster, Klerksdorp, South African Republic, 1st September, 1897; 6 years. (Filed 10th August, 1897.)

*Claim.*—1st. A boring crown, cutter-head, saw or other rock stone or similar boring, cutting or like tool or appliance on or to which or on or to an intermediate part to be attached to which the diamonds or carbons are set or fixed by means of the electro-deposition of a suitable metal, substantially as described. 2nd. A boring crown for diamond core or similar drills in which the diamonds or carbons composing the working face are set by means of the electro-deposition of a suitable metal, the said working face being rounded and formed with steps or recesses on their outer and inner rims or edges to form a bearing surface at right angles to the path of travel of the crown, for the carbons disposed around the edges, provided with means for attaching same to the drill rod or core barrel, substantially as described and shown. 3rd. The method or mode of setting or fixing the diamonds or carbons to or on the boring or cutting face or edge of a boring crown cutter-head, saw or other rock, stone or like boring, cutting, shaping or working tool, appliance or machine, consisting in the electro-deposition of a suitable metal on the surface of the tool, or an intermediate piece to be affixed thereto, which electro-deposition is carried on or continued until the carbons are held or secured in position on the face of the tool or intermediate piece by the metal so deposited, substantially as described. 4th. The method or mode of setting or fixing the diamonds or carbons to or on the boring or cutting face or edge of a boring crown, cutter-head, saw or other rock, stone or like boring, cutting, shaping or working tool, appliance or machine, consisting in the electro-deposition of a suitable metal on the surface of the tool, or an intermediate piece to be affixed thereto, which electro-deposition is continued until the carbons are completely enveloped by or embedded in the metal so deposited and then removing the irregular or superfluous metal by turning, grinding or otherwise until the points of the carbons are exposed, substantially as described. 5th. The method or mode of setting or fixing the diamonds or carbons to or on the boring or cutting face or edge of a boring crown, cutter-head, saw or other rock, stone or like boring, cutting, shaping or working tool, appliance or machine, or an intermediate piece to be affixed thereto comprising the arrangement or placing of the carbons after they have been brushed or otherwise coated with a film of black lead to assist electro-deposition, in position in a mould having the same, or approximately the same shape internally as the working face of the

tool or intermediate piece externally to which a coating of wax, gutta-percha or like non-conducting plastic and adhesive substance has been given to support the carbons when slightly pressed therein, then attaching the portion of the tool or intermediate piece to the mould in such a manner that the surface to which the carbons are to be attached is supported directly over them, the other parts of the surface of the tool or piece being insulated to prevent deposition taking place thereon, then placing the same in an electro-plating bath and therein depositing a suitable metal on the surface of the portion of the tool or intermediate piece to receive the carbons and continuing said electro-deposition until the carbons are completely enveloped in or embedded by the metal so deposited, and finally removing the irregular or superfluous deposited metal by turning, grinding or otherwise until the tips or points of the carbons are exposed, substantially as described. 6th. A mould for use in the process or method of setting or fixing the diamonds or carbons to or on the boring or cutting face or edge of a boring crown, cutter-head, saw or other rock, stone or like boring, cutting, shaping or working tool appliance or machine or to an intermediate vehicle or piece to be attached thereto, by the electro-deposition of a suitable metal as hereinbefore described, constructed of the same or approximately the same shape internally as the working face of the tool or intermediate piece externally with the upper edges turned outwards or chamfered off to permit of a free circulation of the solution between the carbons and the surface of the portion of the tool or intermediate piece to which they are to be affixed, when they are connected and placed in the electro plating bath, the mould having had a film or thin coating of wax, gutta-percha or other suitable non-conducting plastic and adhesive substance or material given to it, in order to retain or support the carbons when placed and slightly pressed therein and whilst the electro-deposition is being carried out, said mould being also provided with guide and supporting pins to direct and support the crown in its relative position when placed on or over the carbons arranged therein, and means for attaching it and the tool or part of the tool or intermediate piece together preparatory to their being introduced into the electro-plating bath, substantially as described. 7th. In driving mechanism for diamond core and similar drills, the combination of a suitable motor the piston, drum, disc or other rotating part or member of which is keyed or otherwise suitably connected to a sleeve, free to rotate in bearings formed on or attached to the slide carriage of the drill, through which sleeve the drill rod passes, and to which it is capable of being readily connected and disconnected by means of a clamping screw or other device and means for feeding the slide forward in the slide carriage as the boring proceeds, substantially as described and shown. 8th. In combination, the motor E, comprising an interior rotating member or part which is keyed or otherwise connected or coupled up with a sleeve F, and an external casing J bolted or otherwise affixed to the slide H, the sleeve F free to rotate in the journals G, G<sup>1</sup>, formed on or attached to the slide H, the journals G, G<sup>1</sup>, the oil wells g, g<sup>1</sup> formed therein, the drill rod or core barrel B passing through the sleeve F and capable of being readily connected thereto and disconnected therefrom by means of the clamping screw f, the clamping screw f, the boring crown A, the water swivel f<sup>1</sup>, the slide H, the nut or downwardly projecting part K thereof through which the feed screw L works, the feed screw L, operating crank and handle M and slide carriage N, substantially as described and shown.

**No. 57,269. Carpet-Stretcher. (Tendeur de tapis.)**

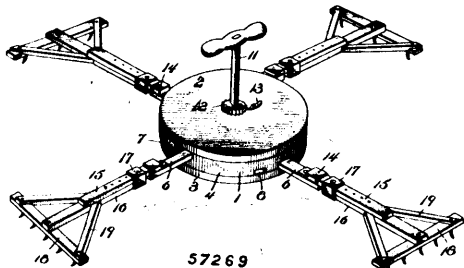

Christopher C. Thompson, Grayson, Kentucky, U.S.A., 1st September, 1897; 6 years. (Filed 10th August, 1897.)

*Claim.*—A carpet-stretcher comprising a casing composed of upper and lower plates having an intermediate rim, said rim provided with two pairs of ways arranged at right angles to each other and in different horizontal planes, two pairs of rack-bars arranged in said ways, the members of each pair extending from opposite sides of the casing, a pinion mounted within the casing and located between the members of both pairs of rack-bars and meshing with and adapted to actuate all of the latter simultaneously, means for operating the pinion and for locking the same against rotation, and carpet-engaging devices connected with the rack-bars, substantially as described.

**No. 57,270. Dray. (Haguet.)**

George W. Dunlop and James F. Cook, both of Vancouver, British Columbia, Canada, 1st September, 1897; 6 years. (Filed 10th August, 1897.)

*Claim.*—1st. In a dray having a goose-neck coupling to the front axle, a bifurcated swivel-clamp, pivoted with its forks on either side

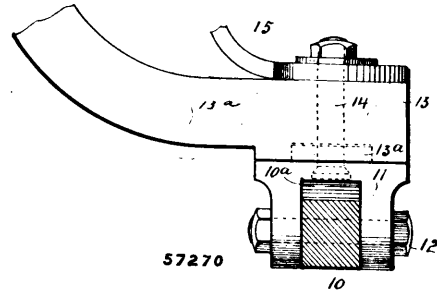

of an enlarged portion of the axle, a projection 11<sup>a</sup> seated in and controlling the hub of a goose-neck, and a bolt 14 securing the whole together, as set forth. 2nd. In a goose-neck and axle for a dray and similar vehicles, the combination of a recessed hub of the said goose-neck 13, a swivel-clamp having a projection 11<sup>a</sup> resting in said recesses, and means for securing the two together, pivotally, of depending forks on the swivel clamp pivotally secured on either side of the enlarged portion of an axle by a stout bolt 12, substantially as set forth.

**No. 57,271. Clothes Holder. (Porte-vêtement.)**

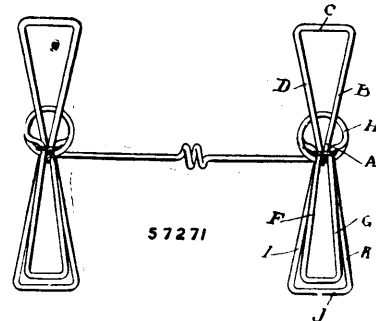

Louisa Wilhelmina Adolffzen, Hastings, Pennsylvania, U.S.A., 1st September, 1897; 6 years. (Filed 10th August, 1897.)

*Claim.*—1st. A clothes holder for the purposes described, consisting of two sets of clamping jaws provided with operating handles and springs, with an actuating rod, said parts being formed from a single piece of wire, substantially as set forth. 2nd. A clothes holder for the purpose described, consisting of two sets of clamping jaws provided with operating handles and springs, and with an actuating rod, said parts being formed with a single piece of wire, and connecting bails, for the purpose described.

**No. 57,272. Connections for Whiffletrees to Cross Bars. (Attelage de palonnier.)**

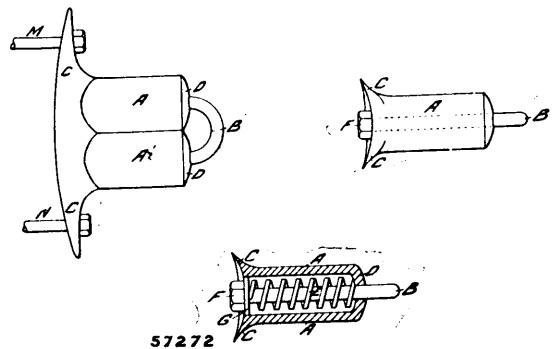

George Heon, Ste. Anne des Saults, Quebec, Canada, 1st September, 1897; 6 years. (Filed 10th July, 1897.)

*Claim.*—1st. The combination of the body A, A<sup>1</sup>, its cover D, and flanges C, with the spiral spring or rubber cushion E, all substantially as and for the purpose hereinbefore set forth. 2nd. The combination of the spiral spring or rubber cushion E, with the arch shaped book B, substantially as described and for the purpose hereinbefore set forth. 3rd. The specially shaped piece B<sup>1</sup> for mode of fastening in the shafts with the spiral spring or rubber cushion E, substantially as shown and for the purpose hereinbefore set forth.

**No. 57,273. Ironing Cabinet. (Meuble à repasser.)**

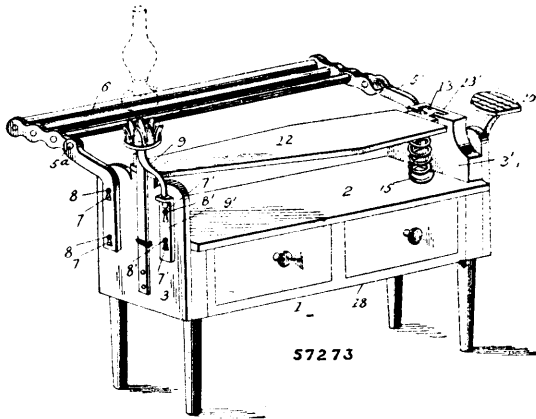

Lydia Elizabeth Dawson, Downing, Wisconsin, U.S.A., 1st September, 1897; 6 years. (Filed 10th August, 1897.)

*Claim.*—1st. The cabinet 1, comprising the top, bottom and side pieces, and provided with the folding clothes rack and swivel lamp and iron supporting brackets, and having its side 3<sup>1</sup>, provided with the T-shaped vertical slot 13<sup>1</sup>, and the side 3, provided with a spring catch 14, in combination with the ironing board 12, formed with the recesses 11, and provided with the T-shaped arm 13, and coiled spring 15, substantially as and for the purpose set forth. 2nd. The cabinet 1, comprising the top, bottom and side pieces, the drawers and the clip springs 16, 17, the flat spring catch 14, the T-shaped vertical slot 13<sup>1</sup>, in combination with the removable ironing board 12, formed with the recess 11, and provided with the T-shaped arm 13, and the coiled spring 15, substantially as and for the purpose set forth. 3rd. A cabinet comprising the top, bottom and the sides provided with the screws 8, 8<sup>1</sup>, 8<sup>2</sup>, the brackets 5, 5<sup>1</sup> and 10, provided with V-shaped slots 7, and the lamp bracket 9, swiveled in the socket 9<sup>1</sup>, formed with the slot 7<sup>1</sup>, and having the side 3<sup>1</sup>, formed with the vertical T-shaped slot 13<sup>1</sup>, and removable board 12, having the spring 15, T-shaped arm 13, substantially as shown and described.

**No. 57,274. Button Hook. (Crochet.)**

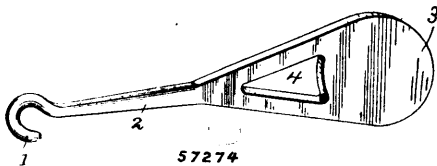

James Allen Haskott, Parsons, Kansas, U.S.A., 1st September, 1897; 6 years. (Filed 10th August, 1897.)

*Claim.*—The design for a button hook, as herein shown and described.

**No. 57,275. Harness. (Harnais.)**

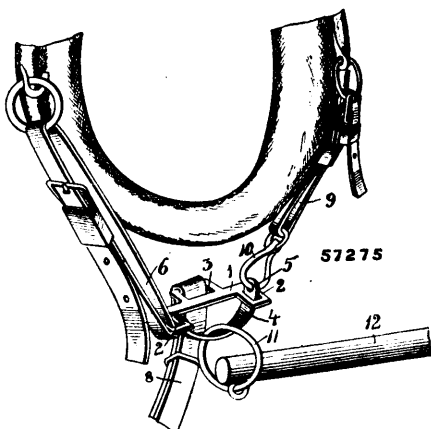

Stephen Arnold Douglas Reynolds, Girard, Illinois, U.S.A., 2nd September, 1897; 6 years. (Filed 10th August, 1897.)

*Claim.*—An attachment for harness, comprising a bar, the ends of which are provided with two loops on one edge of said bar while

the intermediate portion of the other ends is provided with a third loop, a yoke pivoted to one of the end loops, and having its free end projecting upwardly through the opposite end loop, and formed with an eye or opening, substantially as set forth.

**No. 57,276. Car Heating Apparatus.**

(Appareil à chauffer les chars.)

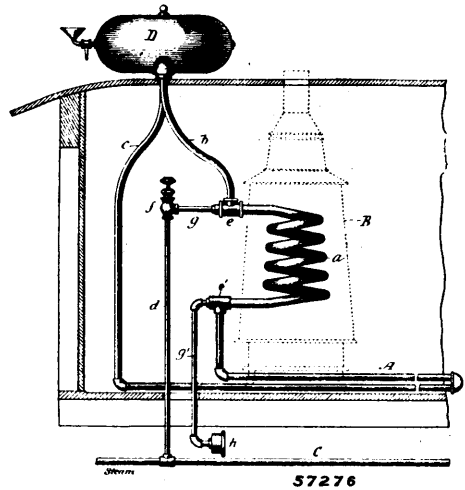

Edward Ethel Gold, New York, State of New York, U.S.A., 2nd September, 1897; 6 years. (Filed 10th August, 1897.)

*Claim.*—1st. The combination with a heating circuit and its expansion tank, of a curved tube communicating from the ascending to the descending pipe, with a terminal nozzle for directing the ascending column of liquid into the descending pipe, and an intervening space around said nozzle communicating with the interior of the expansion tank. 2nd. The combination with a heating circuit and its expansion tank, of a curved tube communicating from the ascending to the descending pipe, with a terminal nozzle for discharging the ascending column of liquid, an enlargement for receiving said column communicating with the descending pipe, and said enlargement open to the interior of the expansion tank. 3rd. The combination with a heating circuit and its expansion tank, of a curved tube communicating from the ascending to the descending pipe, terminating in a downwardly-directed nozzle, with an enlargement at the beginning of the descending pipe arranged to receive the stream from said nozzle, and said enlargement open to the interior of the expansion. 4th. The combination with a heating circuit and its expansion tank, of a tube within the expansion tank forming a passage communicating from the ascending to the descending pipe, terminating in a nozzle, and with a gap or opening in such passage having communication with the interior of the expansion tank. 5th. The combination with a heating circuit and its expansion tank, of a tube communicating from the ascending to the descending pipe having a vent orifice at its upper part, and with a terminal nozzle for directing the ascending column of liquid into the descending pipe, and an intervening space around said nozzle communicating with the interior of the expansion tank. 6th. The combination with a heating circuit and its expansion tank, of a tube communicating from the ascending to the descending pipe, with a terminal nozzle for directing the ascending column of liquid into the descending pipe, contracted to discharge the liquid as a jet, and an intervening space around said nozzle communicating with the interior of the expansion tank. 7th. The combination with a heating circuit and its expansion tank, of a tube communicating from the ascending to the descending pipe, terminating in a downwardly directed nozzle, and an enlargement opening from the bottom of the tank into the descending pipe and receiving the stream from said nozzle. 8th. The combination with circuit A, and tank D, of curved tube E in said tank, terminating in downwardly directed nozzle F, and enlargement G opening from the bottom of the tank into the descending pipe, and into which said nozzle projects.

**No. 57,277. Motor Gear for Ploughs.**

(Moteur à engrenage pour charrues.)

Fritz Brutschke, Charlottenburg, Germany, 2nd September, 1897; 6 years. (Filed 11th August, 1897.)

*Claim.*—1st. An anchoring device for ploughs driven by a wire rope, such device consisting of a ground anchor having several strong flukes or arms and of a rope pulley or roller which are both connected to a carriage frame, in such manner that the rope operates a device for raising the anchor out of the ground, and for moving it in the direction of the furrow away from the machine to enable the anchor to be shifted, and also to compensate for the



movement of the same towards the machine, caused by its entering the ground and so prevent the gradual shortening of the furrows,

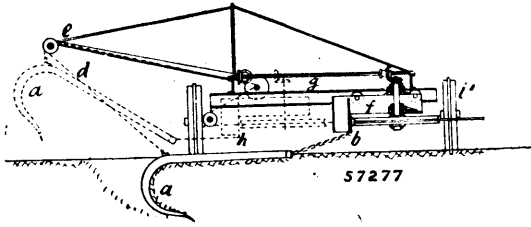

substantially as described. 2nd. In a device of the kind described, arranging the pulley or roller, and anchor to slide in the carriage in the direction of the movement of the plough, as described. 3rd. In a device of the kind described, providing the carriage with wheels mounted on vertical axes, and causing it to move backwards and forwards by gearing in connection with the pulley or roller, as described. 4th. The improvements in and connected with ploughs described and illustrated in the accompanying drawings.

**No. 57,278. Valve. (Soupape.)**

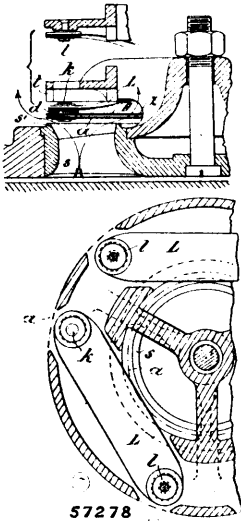

Hans Horbiger, Budapest, Hungary, 2nd September, 1897; 6 years. (Filed 11th August, 1897.)

*Claim.*—1st. In combination with a valve seat, a valve body consisting of a thin plate of metal, a link carrier and an electric link or links secured to such valve body and link carrier, the line connecting the points of attachment of any of the links to the valve body and to the link carrier being in each case in a plane nearly perpendicular to the direction of the movement of the valve body. 2nd. In combination with a valve seat, a valve body consisting of a thin plate of metal, a link carrier and an elastic link or links secured to such valve body and link carrier, such link or links lying in places nearly parallel to the valve seat. 3rd. In combination with a valve seat, a valve body consisting of a thin plate of metal, a link carrier which is also adapted to stop the opening movement of the valve body, and an elastic link or links secured to such valve body and link carrier, the line connecting the points of attachment of any of the links to the valve body and to the link carrier being in each case in a plane nearly perpendicular to the direction of the movement of the valve body. 4th. In combination with a valve seat, a valve body consisting of a thin plate of metal, another plate of metal secured to the back of such valve body with the interposition between the two of distance pieces, a link carrier and an elastic link or links secured to such valve body and link carrier, the line connecting the points of attachment of any of the links to the valve body and to the link carrier being in each case in a plane nearly perpendicular to the direction of the movement of the valve body. 5th. In combination with a valve seat body, a blunt edge inclosing the valve port and projecting from the valve seat body opposite the valve, a valve body consisting of a thin plate of metal, a link carrier and an elastic link or links secured to such valve body and link carrier, the line connecting the points of attachment of any of the links to the valve body and to the link carrier being in each case in a plane nearly perpendicular to the direction of the movement of the valve body. 6th. In combination with a valve seat, a valve supporting rib between the edges of such valve seat, a valve body

consisting of a thin plate of metal, a link carrier and an elastic link or links secured to such valve body and link carrier, the line connecting the points of attachment of any of the links to the valve body and to the link carrier being in each case nearly perpendicular to the direction of the movement of the valve body.

**No. 57,279. Fire Escape. (Sauveteur d'incendie.)**

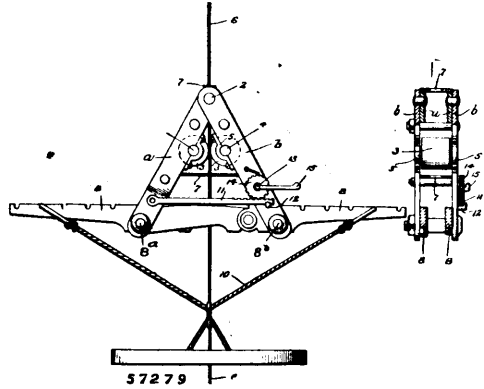

William Ernst Wabnitz, Louisville, Kentucky, U.S.A., 2nd September, 1897; 6 years. (Filed 10th August, 1897.)

*Claim.*—1st. In a fire escape, the combination, with two frames pivoted together and provided with co-operating friction rollers, of jointed levers connected to the lower ends of said frame and provided with notches to engage the bolts of the opposite frames, a tape extending between said rollers, and a sling or strap adapted to be connected to the outer free ends of said jointed levers, substantially as set forth. 2nd. In a fire escape, the combination, with two frames pivoted together and provided with co-operating friction rollers, of jointed levers connected to the lower ends of said frame, and provided with notches to engage the bolts of the opposite frames, a tape extending between said rollers, and a sling or strap adapted to be connected to the outer free ends of said jointed levers, the edges of said levers being provided with graduated notches, substantially as set forth. 3rd. In a fire escape, the combination, with two frames pivoted together and provided with co-operating friction rollers, of jointed levers connected to the lower ends of said frame, and provided with notches to engage the bolts of the opposite frames, a tape extending between said rollers, a sling or strap adapted to be connected to the outer free ends of said jointed levers, and a rack-bar pivoted to one of said frames and projecting across and supporting upon the lugs extending from the other frame, a wheel engaging said rack, and a crank for rotating said wheel to spread or draw together the sections of the frame, substantially as set forth.

**No. 57,280. Car Coupler. (Attelage de chars.)**

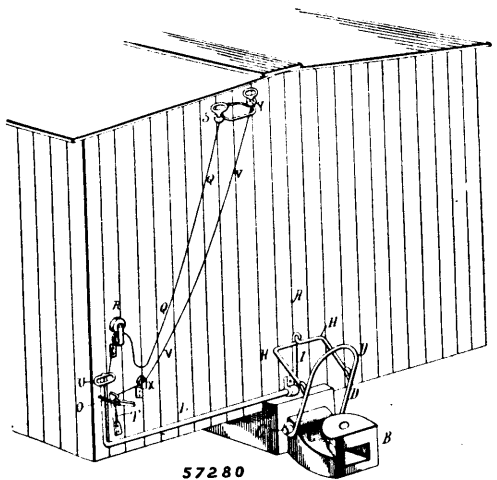

William Curry and George Limerise, both of Sault Ste. Marie, Ontario, Canada, 2nd September, 1897; 6 years. (Filed 11th August, 1897.)

*Claim.*—1st. In a car coupling, a coupling head provided with a hook portion upon its top, combined with a pivoted link, and a suitable operating mechanism therefor, substantially as shown. 2nd. A coupling head, provided with a hook portion upon its top, a coupling link pivotally connected thereto, and a suitable intermediate link, or connection, loosely connected to the link, combined with an operating mechanism connected to the intermediate link,



substantially as described. 3rd. In a car coupling, a coupling head, provided with a hook portion upon its top, a coupling link pivotally connected thereto, and an intermediate link or portion loosely connected to the link, combined with an angular operating lever pivoted upon the end of the car and connected at its inner end to the intermediate link or portion, the outer end of the lever being formed into a handle, substantially as specified. 4th. In a car coupler, a coupling head, a link pivoted thereon, an intermediate link or coupling, and an operating lever pivoted upon the end of the car and provided with bent ends, combined with a spring or support having its upper end bent so as to catch behind the outer end of the lever, and form a support therefor, substantially as shown. 5th. A coupling head, a coupling link pivotally connected thereto, an intermediate link, and an operating lever having bent ends pivoted upon the ends of the car, and which is loosely connected at its inner end to the intermediate link or coupling, combined with a guiding rod which projects from the end of the car, a spring or support having an upper bent end, and operating cords, wires or chains, connected both to the upper end of the operating lever and to the spring or support, and which cords, wires or chains have their upper ends supported at or near the top of the car ready for use, substantially as described.

**No. 57,281. Horse-Shoe. (Fer à cheval.)**

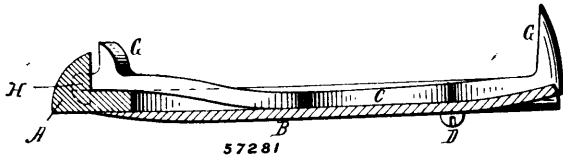

William Henry Orr, Beauséjour, Manitoba, Canada, 2nd September, 1897; 6 years. (Filed 11th August, 1897.)

*Claim.*—1st. An attachment for a horse-shoe consisting of a plate which can be inserted between the shoe and the foot, combined with bars connected thereto, and provided at their ends with caulks, substantially as shown. 2nd. An attachment for a horse-shoe consisting of a thin plate which is inserted between the foot and the shoe, combined with bars which are connected to the plate and which are provided with caulks, and have their front ends turned upwardly so as to catch against the front edge of the shoe, substantially as described. 3rd. An attachment for a horse-shoe consisting of a thin plate, combined with bars which are removably connected thereto, and have their front ends bent or curved upwardly so as to pass over the bottom of the shoe, and are provided with upturned portions H, which catch against the front edges of the shoe, both bars being provided with caulks, and having a turning movement upon the plate, substantially as set forth.

**No. 57,282. Folding Table. (Table pliante.)**

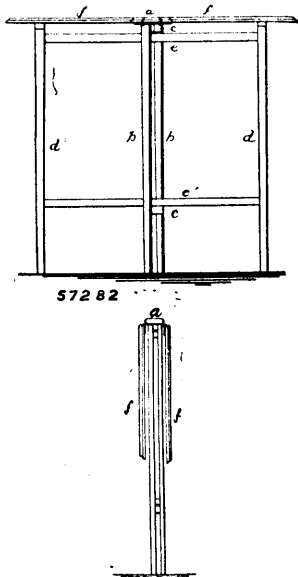

Frank Jerome Carpenter, Canastota, New York, U.S.A., 2nd September, 1897; 6 years. (Filed 13th August, 1897.)

*Claim.*—A folding table comprising a narrow centre piece having leaves hinged thereto and mounted upon stationary legs connected by cross rails, swinging standards pivoted to said cross rails, cam lugs secured to the lower face of the leaves, with which lugs the tops of the swinging standards are adapted to engage, and a spring engaging the cross rails which connect the standards as described for the purposes set forth.

**No. 57,283. Hose Coupling. (Joint de boyau.)**

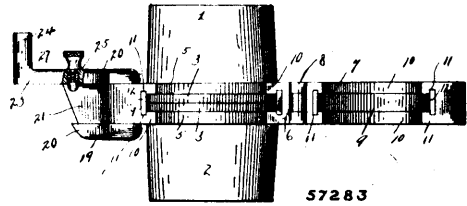

Frank Minson, Ithaca, Michigan, U.S.A., 2nd September, 1897; 6 years. (Filed 12th August, 1897.)

*Claim.*—The combination with two pivotally-united parts of a hose-coupler, of a latch upon one part, a cam upon the other part adapted to co-operate with the latch to close the coupler, a pin upon the latch, an aperture in that part of the coupler that carries the cam adapted to receive the pin and fasten the latch, and the handle upon the latch, substantially as set forth.

**No. 57,284. Fluid Pressure Motor.**

(Moteur à pression hydraulique.)

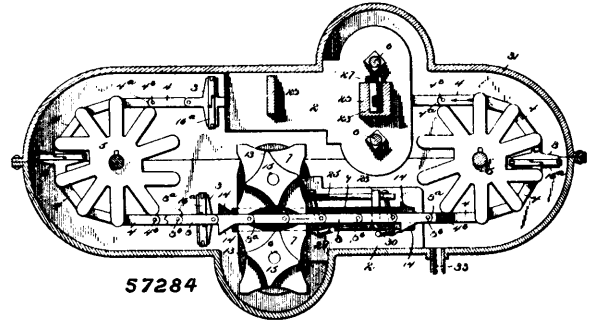

Peter C. N. Pederson, West Superior, Wisconsin, U.S.A., 2nd September, 1897; 6 years. (Filed 16th August, 1897.)

*Claim.*—1st. A fluid-pressure motor having an expansion-chamber, a piston comprising a plurality of flexibly-connected piston-heads adapted to pass successively through the expansion-chamber in a common direction, co-operating movable gates located at the inlet end of the expansion-chamber with their inwardly-extending aligned wings in the path of the piston-heads as they successively approach the expansion-chamber, gate-locking devices for normally holding the gates in their closed or adjusted positions, and trip mechanism for releasing the gates preparatory to the admission of an approaching piston-head, substantially as specified. 2nd. A fluid-pressure motor having an expansion-chamber, a piston having a plurality of spaced piston-heads adapted to pass successively through the expansion-chamber, a traveller operatively connected with the piston for coincidental movement, and connections between the traveller and said gates, whereby the latter are reversed successively as they are approached by the piston-heads, substantially as specified. 3rd. A fluid-pressure motor having an expansion-chamber, a piston having a plurality of spaced piston-heads adapted to pass successively through the expansion-chamber, a traveller operatively connected with the piston for coincidental movement, and spiders carried by the gates and having their arms arranged in the paths of engaging devices on the traveller, substantially as specified. 4th. A fluid-pressure motor having an expansion-chamber, a piston having a plurality of spaced piston-heads adapted to pass successively through the expansion-chamber, a traveller operatively connected with the piston, spiders carried by the gates and having arms to engage spaced recesses in the traveller, and trip devices for actuating the spiders to cause engagement of their arms with the recesses of the traveller, substantially as specified. 5th. A fluid-pressure motor having an expansion-chamber, a piston having a plurality of spaced piston-heads adapted to pass successively through the expansion-chamber, a traveller mounted for linear movement and operatively connected with the piston, spiders carried by the gates and having arms to engage spaced recesses in the traveller, and trip devices for actuating the spiders to cause engagement of their arms with the recesses of the traveller, substantially as specified. 6th. A fluid-pressure motor having an expansion-chamber, a piston having a plurality of spaced piston-heads adapted to pass successively through the expansion-chamber, a traveller mounted for linear movement parallel with the piston, spiders carried by gates and having arms for successive engagement by the traveller, and cam-faced trips on the traveller for engaging projections on the spiders, to cause engagement of the arms of the latter with the traveller, substantially as specified. 7th. A fluid-pressure motor having an expansion-chamber, a piston having an endless carrier and a plurality of spaced piston-heads adapted to pass successively through the expansion-chamber in a

common direction, rotary winged gates in the expansion-chamber, an endless traveller operatively connected with the piston for continuous movement in a uniform direction, armed spiders carried by the spindles of the gates and having flat bearing surfaces normally in contact with opposite surfaces of the traveller, said traveller having recesses to engage the arms of the spiders, and cam-faced trips on the traveller for successively engaging trip-shoulders located on the spiders between the arms thereof, substantially as specified. 8th. A fluid-pressure motor having an expansion-chamber, a piston having a plurality of spaced piston heads adapted to pass successively through the expansion-chamber in a common direction, gates located at the inlet end of the expansion-chamber, a traveller mounted for movement parallel with the piston, and valve mechanism for admitting motive-agent to the expansion-chamber, said mechanism including trip-arms located in the path of trips carried by said traveller, substantially as specified. 9th. A fluid-pressure motor having an expansion-chamber, a piston having a plurality of spaced heads adapted to pass successively through the expansion-chamber in a common direction, gates for closing the inlet end of the expansion-chamber, valve mechanism having a reversing-bar operatively connected with the controlling-valve, and trip-arms connected with the reversing-bar, and a traveller mounted for movement parallel with the piston and having cam-faced trips for successive engagements with the trip-arms to alternately open and close the controlling-valve, substantially as specified. 10th. A fluid-pressure motor having an expansion-chamber, a piston having a plurality of spaced heads adapted to pass successively through the expansion-chamber in a common direction, gates arranged at the inlet end of the expansion-chamber and provided with exterior spiders, valve mechanism including oppositely-located trip-arms operatively connected with the controlling-valve, and adapted to be successively operated to open and close said valve, a traveller mounted for movement parallel with the piston and provided with means for engaging the arms of said spiders on the gates, and cam-faced trips for successively engaging projections on the spiders and said trip-arms, substantially as specified. 11th. A fluid-pressure motor having an expansion-chamber, valve mechanism, and a piston-head to operate in the expansion-chamber, said piston-head being provided with packing devices consisting of angular terminally-interlocking packing-strips, each having pivotally connected arms, and means for yieldingly holding said strips in their extended positions, substantially as specified. 12th. A fluid-pressure motor having an expansion-chamber, valve mechanism, and a piston-head to operate in the expansion-chamber, said piston-head being provided with packing devices consisting of angular terminally-interlocking strips, guard-plates spanning the interlocking extremities of the contiguous strips and carried by the extremity of one of them, and means for yieldingly holding the strips extended, substantially as specified. 13th. A fluid-pressure motor having an expansion-chamber, gates for closing the inlet end of the expansion-chamber, and valve mechanism, in combination with a piston having a flexible carrier, and a plurality of piston-heads adapted to pass successively through the expansion-chamber, said carrier consisting of hingedly connected sections provided at their contiguous extremities with interlocking eyes, fulcrum pins engaging the interlocking eyes, and locking-pins transversely engaging said fulcrum pins to secure them against accidental displacement, substantially as specified.

**No. 57,285. Car Brake for Street Railways.**  
(Frein de chars.)

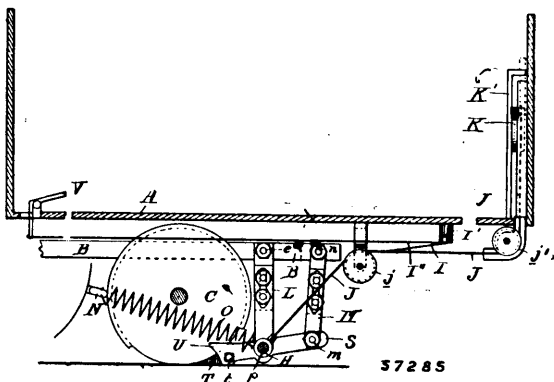

Patrick Flood, Albany, New York, U.S.A., 2nd September, 1897; 6 years. (Filed 16th August, 1897.)

*Claim.*—1st. An emergency brake consisting of a brake-shoe, a portion thereof pivoted and capable of slight vertical movement and adapted to be inserted between the periphery of the wheel and the face of the track, said shoe arranged to swing supported by suitable links, a rod extending from one brake-shoe to the other, a spring connecting said rod with the truck or motor, so arranged that the action of the spring will tend to force the brake-shoe in contact with the wheel, a rope or chain connected with said rod and adapted to be held in position by means of a lever by the operation of which

the brake may be withdrawn and held from contact with the wheel, substantially as described and for the purpose set forth. 2nd. In an emergency brake, the combination of a brake-shoe, a portion thereon movable on a pivot and adapted to be inserted between the rail and the wheel, a device for limiting the movement of said pivoted portion of said brake-shoe, said brake-shoe provided with an elongated slot, a rod extending from one side of the car to the other passing through said elongated slot, a link pivoted to the truck secured to said rod, with an auxiliary link pivoted at one end to the truck, at the other to the shoe, said links together forming a swinging frame for said shoe, a spring connected with the truck or motor attached to said rod, the resiliency of which tends to force the brake-shoe beneath the wheel, a means for withdrawing the brake-shoe from contact with the wheel and holding the same in such position, substantially as described and for the purpose set forth.

**No. 57,286. Wheels for all kinds of Vehicles.**  
(Roue de voitures.)

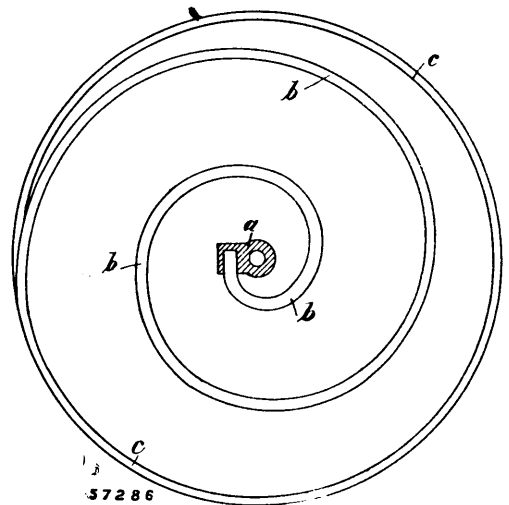

Conrad Slonka, Lange Gasse 33, Cracow, Galicia, Austria, 2nd September, 1897; 6 years. (Filed 16th June, 1897.)

*Claim.*—1st. In a wheel for vehicles of all kinds a nave *a*, and one suitably bent spoke *b*, the inner end of which is firmly inserted into said nave whilst its outer part forms the wheels rim *t*, substantially as set forth. 2nd. A wheel for vehicles of all kinds, comprising a nave *a*, and a plurality of suitably bent spokes *b*, the inner ends of which are firmly inserted into said nave, whilst their outer ends form the felloes *t* of the wheel, substantially as set forth. 3rd. In a wheel for vehicles of all kinds, a nave *a* and one suitably bent spoke *b*, the inner end of which is firmly inserted into said nave, whilst its outer part forms the wheels rim *t*, and its cross-section goes diminishing from inner to outer end, substantially as set forth. 4th. A wheel for vehicles of all kinds, comprising a nave *a*, and a plurality of suitably bent spokes *b*, the inner ends of which are firmly inserted into said nave, whilst their outer ends form the felloes *c* of the wheel and their cross-section goes diminishing from inner to outer end, substantially as set forth.

**No. 57,287. Down Draft Heating Apparatus.**  
(Appareil de chauffage à courant d'air.)

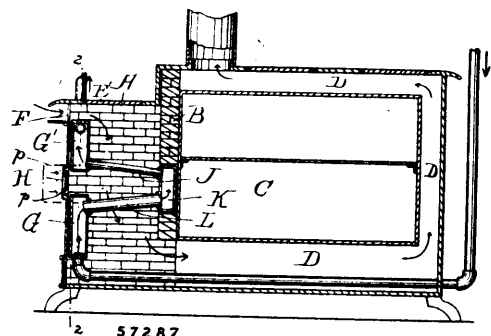

Howard De Wolfe Sawyer, Beachmont, Revere, Massachusetts, U.S.A., 2nd September, 1897; 6 years. (Filed 16th August, 1897.)

*Claim.*—1st. In a down-draft heating apparatus, the fire-pot having a hollow, water-containing front made in two independent

sections, one above the other, in combination with the tubular water grate extending obliquely downward from the lower part of the upper section, the water supply pipes beneath the grate, inclined in the opposite direction and entering the upper part of the lower section, and with the water box at the inner or back end of the fire-box into which the converging supply pipes and grate tubes enter, substantially as set forth. 2nd. In a down shaft heating apparatus, the front wall formed of two independent water-containing sections and a door closing the open space between them, with a draft inlet above and an ash door below said sections, in combination with a water box at the rear end of the fire-box and with reversely inclined grate tubes and supply pipes connecting respectively the upper and lower sections to said water box, whereby circulation is enforced through the several parts, substantially as set forth.

**No. 57,288. Heating Stove. (Poêle de chauffage.)**

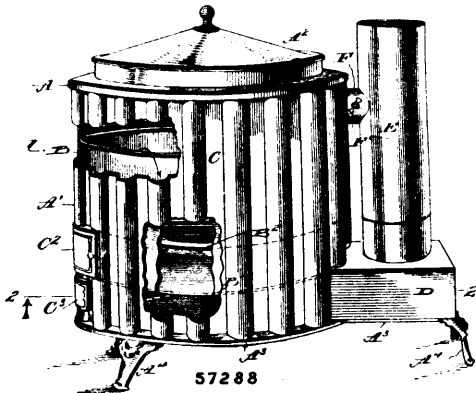

Alfred Goldie Ryley, Memphis, Tennessee, U.S.A., 2nd September, 1897; 6 years. (Filed 16th August, 1897.)

*Claim.*—1st. A heating stove provided with a body portion composed of an inner cylinder and a corrugated surface disposed one within the other, substantially as specified. 2nd. A heating stove provided with a body portion composed of an inner cylinder and a corrugated surface disposed one within the other, and secured to each other at their points of contact, substantially as specified. 3rd. A heating stove provided with a body portion composed of an inner cylinder and a corrugated surface disposed one within the other, one of said portions being extended above and below the other portion and provided with a base and top, substantially as specified. 4th. In a stove, a base, a corrugated body portion supported thereon, a top upon said body portion, an interior cylinder in contact with said corrugated portion, and an outlet flue communicating with the lower portion of said body, substantially as specified. 5th. In a stove, a base, a corrugated body portion supported thereon, a top upon said body portion, an interior cylinder in contact with said corrugated portion, and an outlet flue having inwardly extended walls located beneath the inner cylinder, substantially as specified. 6th. In a stove, a corrugated portion having at the base of and between the corrugations substantially straight portions, a member located in contact with said straight portions, one of said portions constituting the body of the stove being extended above and below the plane of the other and provided with base and top members, substantially as specified. 7th. In a stove, a corrugated portion, an inner body portion located in contact therewith, one of said body portions being extended above and below the other and provided with base and top portions, and an outlet flue communicating with the lower portion of said stove, substantially as specified.

**No. 57,289. Filter and Method of Washing the Same. (Filtre et méthode de le laver.)**

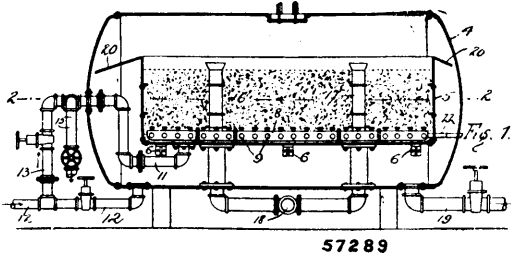

Omar Hestrian Jewell and William Marshall Jewell, both of Chicago, Illinois, U.S.A., 2nd September, 1897; 6 years. (Filed 8th July, 1897.)

*Claim.*—1st. In a filter, the combination with an external tank of an internal filter tank arranged therein and adapted to contain the filter bed, means for causing a flow of water upward through

said filter tank and over the edges thereof, and means for directing the overflowing water away from the sides of said tank, substantially as described. 2nd. In a filter, the combination with an external tank having a concave bottom, of an internal filter tank arranged therein and adapted to contain the filter bed, means for causing a flow of water upward through said filter tank and over the edges thereof, and means for directing the overflowing water away from the sides of said tank, substantially as described. 3rd. In a filter, the combination with an external tank having a concave bottom, of an internal filter tank arranged therein and supported above the bottom thereof, said internal tank being arranged to contain the filter bed, means for causing a flow of water upward through said filter tank and over the edges thereof, and means for directing the overflowing water away from the sides of said internal tank, substantially as described. 4th. In a filter, the combination with a horizontal, cylindrical external tank, of an internal filter tank arranged therein and supported above the bottom thereof, said filter tank being adapted to contain the filter bed, means for causing a flow of water upward through said filter tank and over the edges thereof, and means for directing the overflowing water away from the sides of said internal tank and against the sides of the external tank, substantially as described. 5th. In a filter, the combination with a filter tank, of a manifold therein, branch pipes connected to said manifold, an air pipe in said manifold and having branches extending into said branch pipes, discharge orifices in said branch pipes, and means for supplying gas under pressure to said air pipe, substantially as described. 6th. In a filter, the combination with an external tank, and an internal tank arranged therein, of one or more overflow wash pipes opening into said filter tank below the upper edges thereof, and means for closing said overflow pipe or pipes to cause the wash water to overflow the internal tank, substantially as described. 7th. In a filter, the combination with a cylindrical tank, of a filter tank arranged therein and adapted to contain the filter bed, means for directing the flow of water upward through said filter tank and over the edges thereof for washing the external tank, and one or more deflectors carried by said filter tank for discharging the wash water against the walls of said cylindrical tank, substantially as described. 8th. In a filter, the combination with a filter tank adapted to contain a filter bed, of pipes having a series of discharge orifices under said filter bed for introducing water under pressure into the lower part of said filter bed, and a series of jet openings arranged in said pipes coincident with said discharge orifices for injecting gaseous blasts through the orifices, substantially as described. 9th. In a filter, the combination with a cylindrical tank, of a rectangular filter tank arranged therein adapted to contain the filter bed, means for directing the flow of water upward through said filter tank and over the edges thereof for washing the external tank, and deflectors at the sides and ends of said filter tank for directing the wash water against the walls of said cylindrical tank, substantially as described. 10th. The method of agitating the filter bed of a filter which consists in forcing gaseous blasts into said filter bed from below, substantially as described. 11th. The method of agitating the filter bed of a filter which consists in forcing gaseous blasts into said filter bed from below, and simultaneously introducing water into the filter bed, substantially as described.

**No. 57,290. Double-acting Pump. (Pompe à double effet.)**

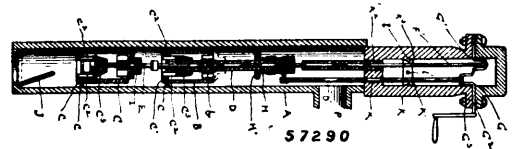

Frederic C. Matteson, Hanston, Kousas, U.S.A., 2nd September, 1897; 6 years. (Filed 12th August, 1897.)

*Claim.*—1st. In a double-acting pump, the combination with the upper piston B, comprising a hollow cylinder having a spider-like core at its upper portion, a cup-leather c seated against the bottom edge of the said cylinder, a ring c<sup>1</sup> which secures the said cup-leather, and which has a series of arms c<sup>2</sup> which extend up into said cylinder, and a threaded nut at the upper end of said arms, of a hollow rod-section screwed into said core and into the said nut, a lift-valve seated around said section upon the upper end of the piston, a stuffing-box at the upper-end portion of the said section having a collar which forms a stop for said valve, and a pump-rod or link connected to said box, together with a lower piston of similar form to the upper one, and having a rod which extends up through said hollow section and stuffing-box, and means whereby the said rods are actuated to oppositely reciprocate the said pistons, substantially as specified. 2nd. In a pump, the combination of a pump-cylinder or barrel, the two pistons or plungers which work therein one above the other, the valves therefor, the pump-rods connected to said cylinders, one of said rods having the hollow sections D<sup>2</sup> and D<sup>4</sup>, through which the other rod extends, and which are connected by a rod-section D<sup>4</sup>, the crank shaft journalled in a suitable head and having opposite cranks, and the links which connect said cranks with the respective pump-rods, substantially as specified.

**No. 57,291. Hammer. (Marteau.)**

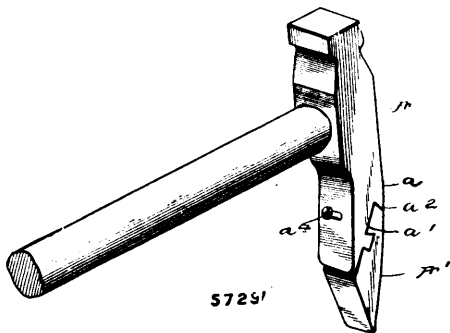

Thomas W. Mackie, Eldred, Pennsylvania, U.S.A., 2nd September, 1897; 6 years. (Filed 2nd July, 1897.)

*Claim.*—The combination, with the body portion of a hammer having an inwardly-sloping flange thereon, said body portion being cut off from the bottom of said flange, and having a transverse dove-tailed tenon upon said body portion in front of said flange, a spring-pressed plunger situated to extend beyond the base of said cut-off portion, of an end portion bevelled at its end to fit the inwardly-sloping flange of said body portion, having a transverse dove-tailed mortise to receive said tenon, and a recess to receive said plunger.

**No. 57,292. Tube Making Process. (Procédé pour faire les tubes.)**

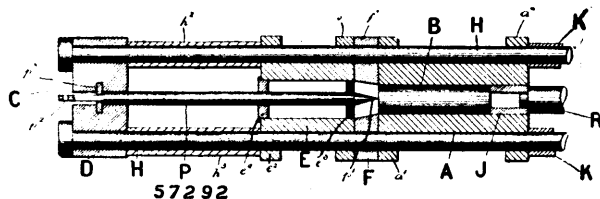

Thomas Budworth Sharp and Frederick Billing, both of Birmingham, Warwick, England, 2nd September, 1897; 6 years. (Filed 13th July, 1897.)

*Claim.*—1st. Forming metal tubes from a billet contained in a cylinder by forcing the said billet on to a pointer or piercer, the end of which is pointed and preferably situated in another cylinder, in the manner substantially as hereinbefore described and as shown upon the drawings. 2nd. Forming metal tubes from a hollow billet or partially formed tube contained in a cylinder by forcing the said shell or hollow billet on to a pointer or piercer in the manner substantially as hereinbefore described and as shown upon the accompanying drawings. 3rd. Forming metal tubes from a hollow or solid billet contained in a cylinder by imparting an intermittent motion to a piercer which nips and thereby reduces the thickness of the wall of the billet by squeezing it against the mouth of a die or billet cylinder, the said billet being advanced by an intermittent motion after the piercer has withdrawn, in the manner substantially as hereinbefore described and as shown upon the accompanying drawings. 4th. Forming metal tubes from a hollow billet or partially formed tube supported internally by the prolonged end of a piercer or plunger by imparting an intermittent motion to the said piercer which nips and thereby reduces the thickness of the wall of the billet or partially formed tube by squeezing it against the mouth of a die or its equivalent, the said billet being advanced by an intermittent motion after the piercer has been withdrawn in the manner substantially as hereinbefore described and as shown on the accompanying drawings. 5th. Forming metal tubes from a hollow billet or partially formed tube by forcing the said hollow billet or partially formed tube by an intermittent motion into the trumpet shaped mouth of a die, the said tube being then further forced through the die by the plunge of a piercer or plunger which nips and thins down the wall of the tube by squeezing it against the mouth of a die or its equivalent in the manner substantially as hereinbefore described and as shown on the accompanying drawings. 6th. In machines for forming metal tubes the arrangement for saving metal when the partially finished tube is nearly pierced consisting essentially of one two or more hollow cylinders, the inner cylinder or cylinders being held in position by a cotter or cotters or equivalents and a solid rod or core fitted in the cylinder when only one is used or in the innermost cylinder when more than one is used and held in position by a cotter pin or its equivalent in the manner substantially as hereinbefore described and as shown upon the accompanying drawings. 7th. In machines for forming metal tubes the arrangement for reducing the power necessary for thinning down the wall of the ingot or partially formed tube and also for acting as a buffer for preventing breakages consisting essentially of a spring under partial compression which spring is suitably held or contained and interposed between the pusher which is caused to urge the tube forward and the hydraulic ram or screw arrangement or other suitable source of power which is the means of causing the pusher to urge the tube forward substantially as hereinbefore described and as shown upon the drawings. 8th. In machines for forming metal tubes the arrangements as shown consisting essentially of a spring under partial compression which spring acts only on the inner part of the pusher and which allows the said inner part of the pusher to automatically yield before the advance of the piercer in the manner and for the purpose substantially as hereinbefore described. 9th. The improvements in tubes manufactured by compressing the billet into a hollow condition to be followed or not by afterwards drawing the same on a draw bench in the manner substantially as hereinbefore described and as shown upon the accompanying sheets of drawings.

*Claim.*—1st. A packet fastener comprising two casings of flexible material, stiffeners in said casings, said stiffeners being smaller than the casings to leave extended flexible portions, means for securing the casings together through the extended flexible portions at a point adjacent to the lower ends of the casings and fastening devices for securing the casings against separation, substantially as described. 2nd. A packet fastener comprising two casings of flexible material, stiffeners within said casings, said stiffeners being narrower than the casings and arranged to leave the adjacent edges of the casings outlying and flexible, means for securing the casings together at one end through the adjacent flexible edges thereof whereby when the casings are brought together said edges will overlap and the stiffeners in the casings will lie parallel and in substantially the same plane and fastening devices on the casings for securing them against separation, substantially as described. 3rd. A packet fastener comprising two casings of flexible material, resilient stiffeners in the casings, said stiffeners being narrower than the casings to leave flexible edges, means for securing the casings together at one end and fastening devices on the flexible edges, portions of said fastening devices being arranged to overlap the stiffeners to hold them against movement within their casings, substantially as described.

**No. 57,293. Placket Fastener. (Attache de vêtements.)**

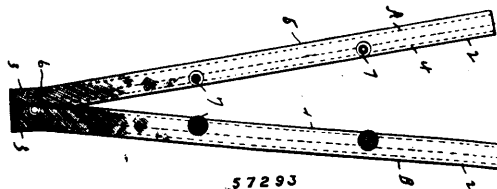

Charles F. Littlejohn, Flushing, New York, U.S.A., 2nd September, 1897; 6 years. (Filed 18th August, 1897.)

*Claim.*—1st. A packet fastener comprising two casings of flexible material, stiffeners in said casings, said stiffeners being smaller than the casings to leave extended flexible portions, means for securing the casings together through the extended flexible portions at a point adjacent to the lower ends of the casings and fastening devices for securing the casings against separation, substantially as described. 2nd. A packet fastener comprising two casings of flexible material, stiffeners within said casings, said stiffeners being narrower than the casings and arranged to leave the adjacent edges of the casings outlying and flexible, means for securing the casings together at one end through the adjacent flexible edges thereof whereby when the casings are brought together said edges will overlap and the stiffeners in the casings will lie parallel and in substantially the same plane and fastening devices on the casings for securing them against separation, substantially as described. 3rd. A packet fastener comprising two casings of flexible material, resilient stiffeners in the casings, said stiffeners being narrower than the casings to leave flexible edges, means for securing the casings together at one end and fastening devices on the flexible edges, portions of said fastening devices being arranged to overlap the stiffeners to hold them against movement within their casings, substantially as described.

**No. 57,294. Interchangeable Gear for Traction Engines. (Engrenage échangeable pour machines à traction.)**

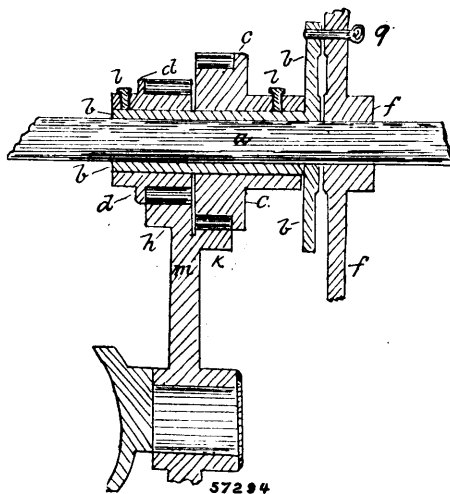

Abraham Merner, Waterloo, Ontario, Canada, 2nd September, 1897; 6 years. (Filed 17th August, 1897.)

*Claim.*—1st. The combination of the larger pinion c, the smaller pinion d, the larger gear h and the smaller gear k, substantially as and for the purpose hereinbefore set forth. 2nd. The combination of the pinions c and d, the sleeve b, and the shaft a, substantially as and for the purpose hereinbefore set forth. 3rd. The combination

of the shaft *a*, the sleeve *b*, the pinions *c* and *d*, the gears *k* and *k*, and the intermediate wheel *m*, substantially as and for the purpose hereinbefore set forth.

**No. 57,295. Bottle Wrapper. (Enveloppe de bouteilles.)**

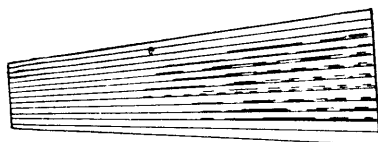

57295

James J. Hinde, Sandusky, Ohio, U.S.A., 3rd September, 1897; 6 years. (Filed 14th July, 1897.)

*Claim.*—1st. A bottle-wrapper formed of paper-board in the shape of a flat tube, said tube having corrugations substantially throughout the convex corrugations of one side fitting in the concave corrugations of the other side, substantially as described. 2nd. A bottle-wrapper formed from paper-board in the shape of a flat tube, having permanent corrugations longitudinally, the corrugations at the neck being deeper than those in the body portion, the convex corrugations of one side fitting in the concave corrugations on the other side. 3rd. A bottle-wrapper formed from paper-board, in the shape of a flat tube, having permanent longitudinal corrugations, the corrugations increasing in depth from the base to the top, the convex corrugations of one side fitting in the concave corrugation on the other side.

**No. 57,296. Piano Action. (Action de pianos.)**

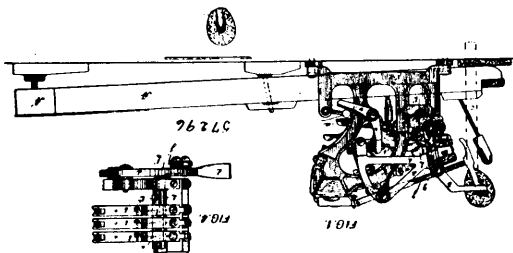

Adam Nickel, New York, State of New York, U.S.A., 3rd September, 1897; 6 years. (Filed 15th July, 1897.)

*Claim.*—1st. A piano action provided with means for changing the leverage and reach of action, and means for simultaneously exerting a downward tension on the action upon the depression of the soft pedal, so as to maintain a uniform stroke of the key, substantially as specified. 2nd. A piano action provided with a rock shaft adapted to be actuated by the soft pedal and with a spring adapted to be engaged by the rockshaft, and to increase the tension of the action upon a depression of the soft pedal, substantially as specified. 3rd. A piano action provided with a wippen, a spring extending rearwardly therefrom, a flanged rock shaft, means for increasing the reach of the action, and means for simultaneously rocking the rock shaft to engage or disengage the spring, substantially as specified.

**No. 57,297. Incandescent Gas Burners. (Brûleur de gaz incandescent.)**

(*Brûleur de gaz incandescent.*)

Ottmar Kern, Paris, France, 3rd September, 1897; 6 years. (Filed 16th July, 1897.)

*Claim.*—1st. The method of raising a refractory body to a higher degree of incandescence, which consists in subjecting the refractory body to the heating effect of the hyperincandescent zone of the flame of a self-burning mixture of air and gas, substantially as described. 2nd. The method of raising a refractory body to a high degree of incandescence, which consists in maintaining such body, as nearly as practicable, in superficial contact with or within the hyperincandescent zone of the flame of a self-burning mixture of air and gas, substantially as described. 3rd. The method of giving high illuminating power to a mantle or hood of refractory material, which consists in maintaining the hyperincandescent zone or zones of a flame or flames of a self-burning mixture of air and gas, as nearly as practicable, in superficial contact with a part or parts of such mantle or hood, substantially as described. 4th. The method of giving high illuminating power to a mantle or hood of interlaced threads of refractory earths, which consists in subjecting the lower portion of such mantle or hood to the heating effect of the hyperincandescent zone or zones of flame or flames of a self-burning mixture of air and gas, substantially as described. 5th. The method of giving high illuminating power to an annular mantle or hood of interlaced threads of refractory earths, which consists in directing

the hyperincandescent zone of an annular flame of a self-burning mixture of air and gas, as nearly as practicable, into contact with a

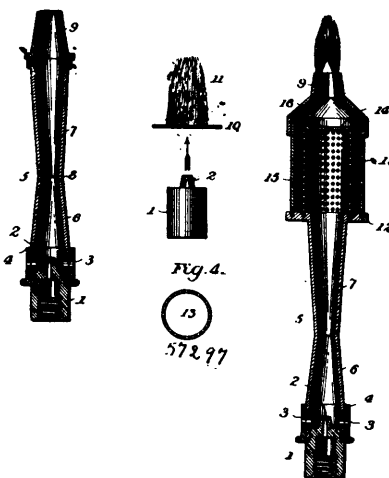
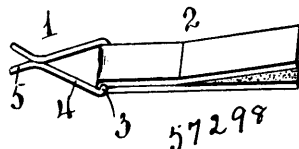

Fig. 4.

57297

portion of the inner surface of said mantle or hood, substantially as described. 6th. An annular gas burner tip, designed for the consumption of a self-burning mixture of air and gas, composed of an exterior cylindrical tube and a concentric interior, upwardly and outwardly widening, conical tube, whereby the outer surface of the hyperincandescent zone of the flame forms, approximately, as a vertical cylinder, substantially as described. 7th. In an incandescent gas burner, designed for the consumption of a self-burning mixture of air and gas, the combination of an annular burner tip constructed to shape the outer surface of the hyperincandescent zone of the flame into an approximately vertical cylinder, with a mantle or hood of refractory threads, concentric with such zone and, as nearly as practicable, in superficial contact with the same, substantially as described. 8th. An incandescent gas burner, composed of two concentric mantles or hoods of threads of refractory material and two concentric annular burner tips, each directing an annular flame into heating proximity to one of the mantles, substantially as described. 9th. An improved Bunsen burner for producing a self-burning mixture of air and gas, composed of an upwardly converging hollow mixing cone, into which the air and gas is admitted, and an upwardly diverging hollow suction cone, having an angle of divergence of not more than ten degrees, substantially as described. 10th. An improved Bunsen burner for producing a self-burning mixture of air and gas, composed of a hollow, upwardly converging truncated cone, whose apex angle is not greater than ten degrees, and into which the air and gas is admitted, and a hollow, upwardly diverging truncated cone, whose apex angle is between the limits of five degrees and seven degrees, substantially as described. 11th. An improved Bunsen burner, composed of an upwardly converging hollow mixing cone, of such determined length as to mix the admitted air and gas into a self-burning compound, and an upwardly diverging truncated hollow suction cone of suitable length, and having an apex angle preferably between five degrees and seven degrees, and not more than ten degrees, the two cones being joined at their smaller bases, substantially as described.

**No. 57,298. Removable Bill Holder. (Porte-billet.)**



Edward Potz, Middleburg, Virginia, U.S.A., 3rd September, 1897; 6 years. (Filed 17th July, 1897.)

*Claim.*—1st. In a device of the kind specified, a loop having its sides normally in contact with each other and separable, and a tab secured to said loop, said tab having one face provided with adhesive matter. 2nd. In a device of the kind specified, a loop consisting of a middle portion, converging sides extending from the ends of said middle portion, and diverging jaws at the ends of said sides, and a tab secured to said middle portion, said tab having one face provided with adhesive matter. 3rd. In a device of the kind specified, a loop having separable sides that are normally in contact with each other, and a tab secured to said loop and consisting of two pieces having their inner faces provided with adhesive matter.

**No. 57,299. Apparatus for Use in Mending and Cleaning Sacks, etc.** (*Appareil pour nettoyer et réparer les sacs.*)

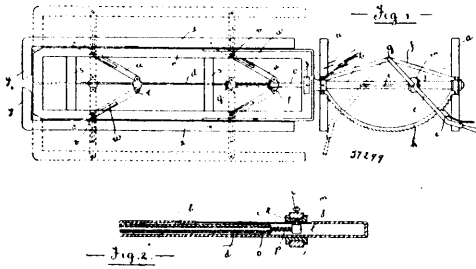

John Henry Orfeur, Milton Road, Stowmarket, Suffolk, England, 3rd September, 1897; 6 years. (Filed 20th July, 1897.)

*Claim.*—The apparatus consisting essentially of a frame the width of which can be varied so as to accommodate itself to and retain thereon a sack or the like, the said apparatus comprising the standards *a*, the tubular shaft *b*, the slot *c*, the spindle *d*, and the lever *e*, the frame *f*, the rack *h*, the spring catch *i*, the collars *j*, the pins *k*, the block *l*, the roller *m*, the stud *n*, the tubular sleeve *o*, the spiral spring *p*, the table *r*, the cross bars *s*, the eared lugs *t* and *u*, the arms *v* and *w*, the slots *x*, the battens *x*, the return ends *y*, and the pins *z*, the whole substantially as described and illustrated.

**No. 57,300. Machine for Measuring.** (*Machine à mesurer.*)

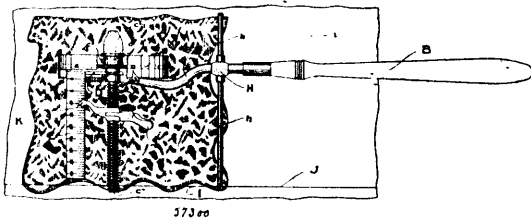

Louis Coté, St. Hyacinthe, Quebec, Canada, 3rd September, 1897; 6 years. (Filed 22nd July, 1897.)

*Claim.*—1st. In a machine for measuring surfaces having an irregular outline, the combination of a wheel *A* provided with a decimal graduation *a*<sup>2</sup>, with a handle *B*, which is provided with an index finger *b*<sup>1</sup>, and a gauge *h*, substantially as described and for the purposes set forth. 2nd. In a machine for measuring surfaces having an irregular outline, the combination of a wheel *A* provided with a threaded shaft *C*, and a travelling index finger *G*, with a handle *B*, provided with a gauge *h* and a graduated scale *E*, substantially as described and for the purposes set forth. 3rd. In a machine for measuring surfaces, having an irregular outline, a travelling index finger *G*, having a smooth borehole *g*<sup>1</sup> through it, and a lever *g*<sup>2</sup>, provided with a projection or tooth *g*<sup>5</sup>, and a spring *g*<sup>6</sup>, substantially as described and for the purposes set forth.

**No. 57,301. Cooking Stove.** (*Poêle de cuisine.*)

Howard DeWolfe Sawyer, Beachmont, Revere, Massachusetts, U.S.A., 3rd September, 1897; 6 years. (Filed 16th August, 1897.)

*Claim.*—1st. In a down-draft cook-stove or range, the fire-pot and the oven, both within the shell or body of the stove proper, and the water-back *F* immediately between them, in combination with the tubular grate *G* through which water circulates freely, and a draft inlet through the stove body above the grate, admitting air downwardly between the grate-bars, and with the caloric passage *C, C, C* surrounding the oven, substantially as set forth. 2nd. In a down-draft cook-stove or range, the interior oven, in combination with the fire-pot within the stove body, and having water-walls, a tubular water-grate therein, and a draft inlet above said grate, and with a caloric passage from such fire pot extending beneath, beyond and over the oven, substantially as set forth. 3rd. In a down-draft cooking and heating stove, the interior oven and the caloric passage surrounding said oven, in combination with the fire-pot having a water-back with water-grate connected thereto, and a water-bottom extending beneath the oven and with inclined water pipes beneath the oven, within the caloric passage, and connecting the extension of said bottom with the water-back, substantially as set forth. 4th. In a down-draft cooking and heating stove, the

oven *A*, enclosed within the shell or body of the stove proper, and the heat passage *C, C, C* encircling the oven, in combination with

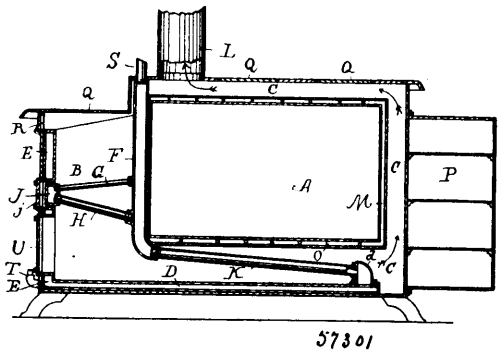

the fire-pot having a water-bottom and water-back, an enclosed water-grate communicating with said water-back, a draft inlet above said grate whereby a downward draft is assured, and flow and return pipes for hot water circulation to adjacent rooms, substantially as set forth, 5th. In a down-draft heating apparatus, the fire-pot having a water-back and a tubular water-grate communicating therewith and extending forward therefrom, in combination with a draft-inlet above the grate, a water-bottom beneath the grate and fire-pot, and running rearwardly beyond said water-back, and a tubular connection between the tip of said water-bottom and the lower part of the water-back, substantially as set forth.

**No. 57,302. Book Support.** (*Support de livres.*)

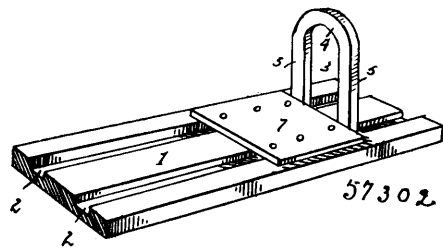

August Lundberg, Worcester, Mass., U.S.A., 3rd September, 1897; 6 years. (Filed 16th August, 1897.)

*Claim.*—The combination with a book-shelf having longitudinal grooves therein, of a book-supporter made up of a curved strip of wire or sheet metal, the arms of which lie parallel with one another and are formed with flanges lying at right angles to the main portion thereof, said flanges being adapted to fit and move within the grooves in said shelf, and a plate of metal separate from, but riveted or otherwise secured to, said flanges, and adapted to slip upon the top surface of said shelf.

**No. 57,303. Dressmaking Chart.** (*Patron pour tailler les basques.*)

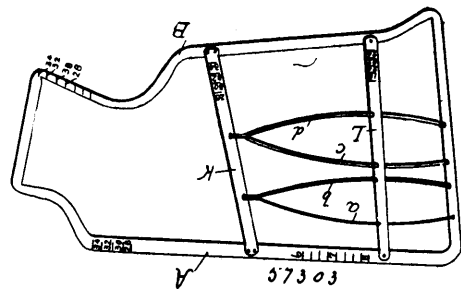

Amedée Maunsey, Fall River, Mass., U.S.A., 3 Septembre 1897; 6 ans. (Déposé le 26 avril 1897.)

*Résumé.*—Un patron pour tailler les basques, consistant en un cadre *A* et des barres transversales *K* et *L*, sur lesquelles viennent appuyer des lignes courbes *a, b, c, d*, le tout tel que montré et pour les fins indiquées.

**No. 57,304. Railroad Crossing.**  
(*Traverse de chemin de fer.*)

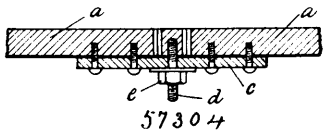
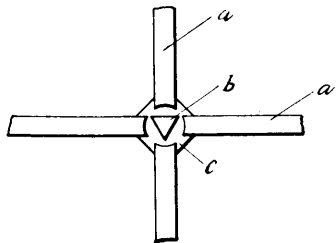

Andrew G. McMeekin, Schenectady, New York, U.S.A., 3rd September, 1897; 6 years. (Filed 17th August, 1897.)

*Claim.*—1st. In a railroad crossing, triangular supporting pieces placed at the intersection of the tracks to partly or wholly bridge across the gaps in the rails, and adapted to be rotated when struck by the car wheels so as not to interfere with the passing of the cars, substantially as described. 2nd. In a railroad crossing, supporting pieces, free to rotate and change in position, to bridge across the gaps in the rails, and said pieces being operated by direct contact of the same with the car wheels, for the purpose set forth. 3rd. In a railroad crossing, supporting pieces placed in the gaps at the intersection of the rails, the pieces being free to rotate and adapted to be moved into position by direct contact of the same with the wheels of the passing cars so as to partly bridge across the gaps in the rails, as set forth. 4th. The combination of tracks crossing each other, and pivoted triangular pieces free to rotate and interposed or placed at the gaps in the rails, which pieces are rotated by the flange of the car wheels, as set forth.

**No. 57,305. Land Roller.** (*Rouleau d'agriculture.*)

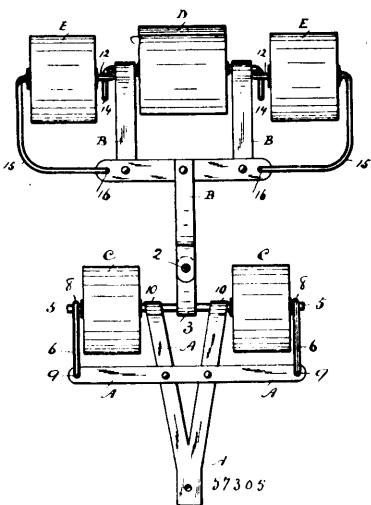

Peter M. Bawtinbirmir, Ancaster, Ontario, Canada, 3rd September, 1897; 6 years. (Filed 19th August, 1897.)

*Claim.*—1st. A machine of the character described consisting of two front rollers attached to the fore part of the machine by means of a coupling and pivot, substantially as described and set forth. 2nd. A machine of the character described, consisting of the combination of narrow rollers attached to the rear end of the frame, the outer rollers capable of rising and falling by means of their pivotal connections to said frame, substantially as described. 3rd. A land roller of the character described consisting of two front rollers coupled and independently attached by means of a coupling and pivot, to the front part of the machine in combination with a rear central roller, and side narrow rollers pivotally connected to the frame to allow rise and fall of said side rollers, substantially as described and set forth.

**No. 57,306. Shoe.** (*Chaussure.*)

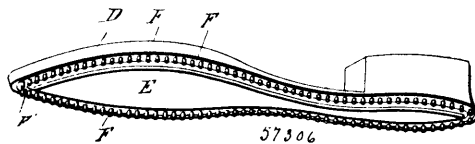

John Ernest Kennedy, Montreal, Quebec, Canada, 3rd September, 1897; 6 years. (Filed 19th August, 1897.)

*Claim.*—1st. The attachment of a sole by means of teeth projecting from the said sole, passing through perforations near the edge of the upper, and then being vulcanized, cemented, fused or welded onto the insole, substantially as set forth. 2nd. The combination with an upper provided with a series of perforation near its lower edges, of an insole of asbestos, cotton, wool or other suitable material, impregnated or coated with india-rubber on its outer or lower surface, and a sole and heel of india-rubber, or other suitable material having an elevated section E adapted to be vulcanized, cemented, fused or welded onto the portion of the insole which is not covered by the overlapping edge of the upper, and a series of teeth formed or set into a concaved channel, these teeth passing through the perforations in the upper and then the whole vulcanized, cemented, fused or welded onto the insole, substantially as set forth. 3rd. The herein described shoe composed of an insole and outsole of suitable material amalgamated into a solid piece, and binding the upper by means of teeth between the edges of the insole and outsole, substantially as described and for the purpose set forth.

**No. 57,307. Veneer.** (*Feuille de placage.*)

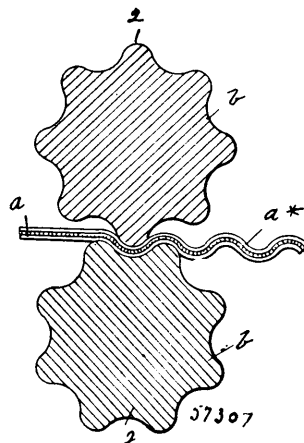

Christian Wilhelm Luther, Reval, Russia, 3rd September, 1897; 6 years. (Filed 20th August, 1897.)

*Claim.*—1st. A compound or built up sheet of veneer rendered ductile by suitable treatment and coated with cement and corrugated, waved, fluted or indented by rollers or other suitable means, and then caused or allowed to set, substantially as herein shown and described. 2nd. Means for corrugating, waving, fluting or indenting compound sheets of veneer comprising an approximately flat lower die, a corresponding upper die formed in sections and means for depressing the several sections in successive order, substantially as herein shown and described.

**No. 57,308. Wheel.** (*Roue.*)

Harry Raymond Collins, South Bethlehem, Pennsylvania, U.S.A., 3rd September, 1897; 6 years. (Filed 20th August, 1897.)

*Claim.*—1st. In a pneumatic hub, the combination of a sleeve or axle, a saddle rotatably mounted thereon, and anti-friction bearings interposed between the sleeve and saddle, with the pneumatic tube, the spoke ring, and means for confining the saddle and spoke ring upon the sleeve, substantially as shown and described. 2nd. The combination of the sleeve having segmental collars, a saddle rotatably supported on the sleeve intermediate said collars, and opposite discs confining said saddle in place upon the sleeve, said discs having segmental projections interlocking with said collars so as to compel the discs to rotate with the sleeve, substantially as shown and described. 3rd. The combination of the sleeve, the saddle rotatably mounted on said sleeve, the pneumatic tube surrounding said saddle, and the spoke ring surrounding said tube, with opposite discs fitted on the sleeve and retaining the saddle and spoke ring in position, and means for locking the said discs to the sleeve so as to cause them to rotate therewith, substantially as shown and de-



scribed. 4th. In a vehicle wheel, the combination with the axle box or sleeve, the saddle sections supported by said sleeve, the in-

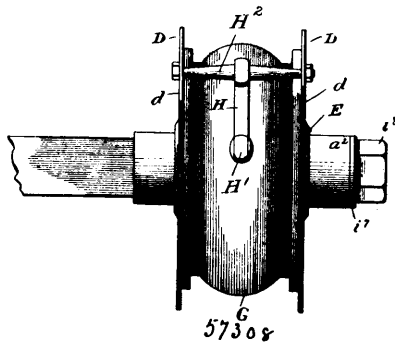

terposed rollers between the sleeve and saddle sections, the discs for preventing lateral movement of the saddle sections, the pneumatic tube carried by said sections, and the spoke ring confining said tube, substantially as shown and described. 5th. The combination of the felly having circumferential divergent grooves, and the hollow split tire having circumferential ribs adapted to engage said grooves, with the retaining devices each having a head fitted in the bore of the tire and a shank passing through the felly, substantially as described. 6th. The combination of the felly having circumferential grooves, a bed-plate having vertical side flanges and interior circumferential gutters fitted in the grooves of the felly, and a tire fitted on said bed-plate having circumferential ribs engaging the gutters, with fastening devices for securing the tire, bed-plate and felly together, substantially as shown and described. 7th. A pneumatic hub for wheels constructed substantially as shown and described with reference to figures 1 and 2 of the drawings. 8th. The antifriction bearings for the hub on the spindle constructed substantially as shown and described with reference to figures 2, 3 and 9 of the drawings. 9th. The wheel rim and tire constructed substantially as shown and described with reference to figures 10 and 11 of the drawings. 10th. As a modification of the devices claimed in claim 9, the construction substantially as shown and described with reference to figure 12. 11th. As a modification of the device claimed in claim 9 the construction substantially as shown and described with reference to figure 13.

**No. 57,309. Device for Removing Broken Rods.**  
(Appareil pour enlever les tiges brisées.)

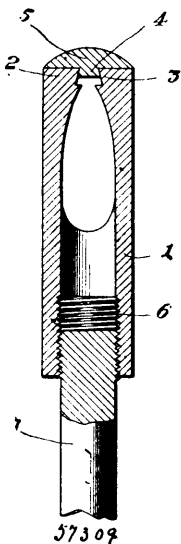

John Hurst, Nelson, Washington, U.S.A., 3rd September, 1897; 6 years. (Filed 20th August, 1897.)

Claim.—1st. In a device for removing broken bits from the holes formed thereby, a permanent magnet having arms resembling those of the ordinary horse shoe magnet and with its loop end cylindrical in form and perforated to receive a stem or handle, substantially as described. 2nd. In a device for removing broken bits, a perma-

nent magnet bifurcated at one end to form the arms of a horse-shoe magnet, said arms terminating at their heel end in a cylinder, screw-threaded to receive a handle or stem, substantially as described. 3rd. In a device for removing broken bits or drills, the permanent magnet having one end bifurcated to form arms resembling those of the horse-shoe magnet, the heel ends of said arms terminating in a longitudinally perforated and internally screw-threaded cylinder, in combination with a handle or stem applied thereto, substantially as and for the purpose described.

**No. 57,310. Gas Burner.** (Bruleur à gaz.)

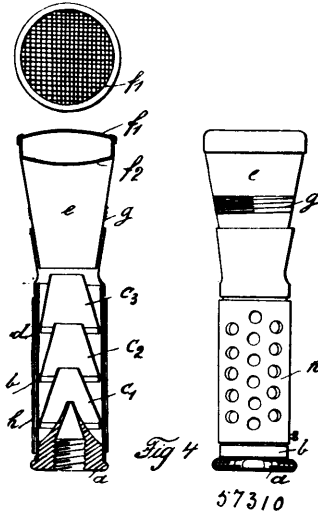

Albert Bandsept, Brussels, Belgium, 3rd September, 1897; 6 years. (Filed 17th August, 1897.)

Claim.—1st. A gas burner in which the gas issuing from an injecting nozzle of convergent section *a*, passes first, through a series of conical tuyeres *c*<sup>1</sup>, *c*<sup>2</sup>, *c*<sup>3</sup>, arranged in a perforated envelope *b* and having their truncated part increasing from one to the other so as to permit the gas current to expand in the shape of a cone and to draw in the required air successively through each tuyere, and second, through an atomiser arranged at the top of the burner in a divergent tube *c* and consisting of two wire gauzes *f*<sup>1</sup>, *f*<sup>2</sup>, *f*<sup>3</sup>, superposed at a short distance. 2nd. The special construction of my burners comprising an atomiser composed of a series of wire gauzes *f*<sup>1</sup>, *f*<sup>2</sup>, *f*<sup>3</sup>, superposed at a short distance from each other and situate immediately under the flame, in combination with an injector composed of several tuyeres, *c*<sup>1</sup>, *c*<sup>2</sup>, *c*<sup>3</sup>, all substantially as described.

**No. 57,311. Cabbage Cutter.** (Coupe-légumes.)

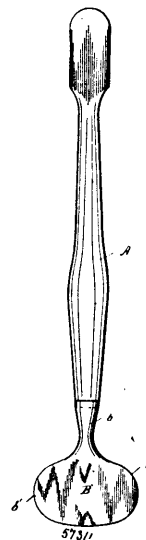

Hubbard Sine, Harold, Ontario, Canada, 3rd September, 1897; 6 years. (Filed 20th May, 1897.)

Claim.—As a new article of manufacture, a cutting instrument, comprising a blade *B*, elliptical in form, and provided with a handle

A, connected to the middle of one of its sides, and having its cutting edge *b*<sup>1</sup> continued around the remaining portions of the blade, substantially as set forth.

**No. 57,312. Gas Engine. (Machine à gaz.)**

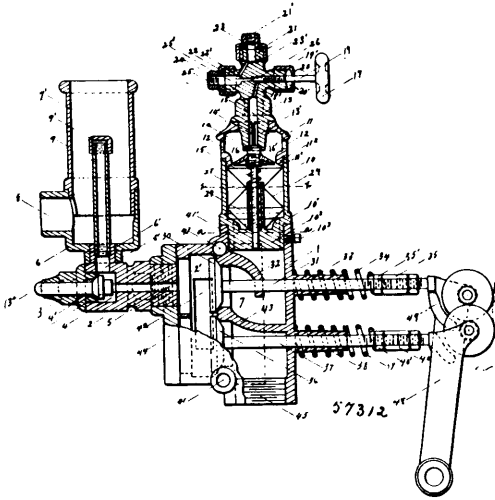

Warren E. White and Edward A. Myers, both of Garrett, Indiana, U.S.A., 3rd September, 1897; 6 years. (Filed 20th May, 1897.)

*Claim.*—1st. In a gas engine attachment, the combination of the valve-body 1 chambered as shown, having an inlet and exhaust opening and provided with an apertured closing plate 44, a chamber casting 2 mounted in said plate as shown, having a screw-threaded plug 3, and provided with an exhaust-valve 3<sup>2</sup> for the purpose specified, an upright igniting tube mounted in said casting, a chimney 7<sup>1</sup> enclosing said tube, a vaporizer body or shell 10 having a series of apertured plates 27 mounted therein as shown, and having a concentric upright tubular casing 28 and provided with a cap 11, having lateral perforations 12, a flaring pendant bottom having a fixed annular plate 11 thereon, a screw-plug 13 channelled as described for the feed-valve, and having an adjustable feed-valve arranged therein, a feed-valve 14 seated on the pendant inner end of said plug 13 having a pendant stem 15 loosely mounted in said tubular casing and provided with a spiral retracting spring arranged as shown, a conical disc 16 mounted on said stem as shown and adapted to nearly close the upper end of the vaporizing chamber, the inlet valve 30 for the chamber 7, having a spring pressed extended stem whose outer end forms a bearing on the rocker-arm 49, the exhaust-valve 36 having the free end of its spiral pressed stem bearing on the rocker-arm 48, the rocker arms 48 and 49 mounted as described, and means for alternately actuating said arms, all substantially as shown. 2nd. In a gas engine attachment, the vaporizer comprising a shell or body 10 mounted as shown in the supporting valve-body and having an upright tubular casing 28, and a series of perforated obliquely arranged plates 27 for the purpose specified, and provided with a hollow cap 11 having a pendant flaring open base 11<sup>2</sup>, provided upon its perimeter with the oblique annular face 11<sup>1</sup>, in combination with a feed valve body channelled as described for the admission of fuel oil and provided with an adjustable feed-valve 19, and a conical spring pressed valve 14 seated as shown on the lower channelled end of said valve-body having a pendant stem 15 loosely mounted in said tubular casing and in a suitable opening in the open bottom of the shell 12, and adapted to be opened by suction as specified, a bell-shaped disc 16, fixed upon the upper end of said valve stem and adapted to normally close the openings to said base 11<sup>2</sup> when the feed-valve 14 is seated and a spiral retracting spring mounted as shown on said stem and adapted to normally hold feed-valve upon its seat, all substantially as shown. 3rd. In a gas engine attachment, a valve-body 1 chambered as shown in combination with the supply-valve 30 seated as shown, having an extended stem 31 whose outer end bears on the free end of rocker-arm 49, a spiral retracting spring 43 mounted on said stem and adapted to normally hold said valve to its seat, a rocker-arm 45 connected with said valve-stem as described and provided with a revoluble roller 50, the exhaust-valve 36 arranged in said valve-body as shown having an extended stem 37 provided with a coil retracting spring for the purpose specified, and having its outer end fixed in the free end of rocker-arm 48, a rocker-arm 48 arranged as shown provided with a roller 51, and means for alternately actuating said rocker-arms for the purpose of opening said valve against the tension of said retracting spring, all substantially as shown and described. 4th. In a gas engine attachment, a centrifugal governor comprising a casting 62 having a central shaft opening 62<sup>1</sup> and a concentric boss 67 upon both sides thereof, and provided upon its outer face with an annular peripheral flange 62<sup>2</sup>

for the purpose specified, and also provided with a rigid peripheral cam 53, a cam 52 pivotally mounted on the outer face of said casting as described, a hollow pawl 58 pivotally mounted on said casting and adapted for a holding engagement with said cam 52, an annular disc 57 rigidly fixed upon the forward portion of said boss 67 and having the diametric openings 76 and 77, a pair of centrifugal weights arranged in said openings as shown and pivotally mounted in the adjacent face of said casting, the said weights being provided with rigid interlocking arms as described, a rod 79 fixed at one end to one of said weights and loosely mounted on a guide-bracket 78, and a retracting spring 81 arranged as shown and adapted to resist the centrifugal force of said spring, all substantially as described. 5th. In a centrifugal governor, the combination of a main casting 62 centrally apertured for the crank-shaft, having an integral peripheral cam for the purpose specified, a movable cam pivoted on said casting as shown for the purpose described, a pivoted pawl mounted on said casting in operative relation to said movable cam and adapted to normally support the same in its working position, an annular disc face plate rigidly fixed to said main casting and provided with diametric oblong openings, a pair of centrifugal weights pivotally mounted on said casting and arranged in said openings of the face plate and provided with rigid interlocking arms as shown, a rod 79 fixed as shown to one of said weights in parallel relation with said face plate and loosely mounted in a fixed guide bracket on said casting, an adjustable retracting spring 81 mounted as shown on said rod and adapted to resist the centrifugal force of said weights, all substantially as described. 6th. In a gas engine attachment, the combination of the valve-body 1, a vaporizing shell mounted therein, a channelled casting 2 detachably mounted in said valve-body having an open chamber 4, a longitudinal conduit 5, and a vertical boss 6<sup>1</sup> provided with a channel 8<sup>1</sup>, a proper chimney enclosing said tube, a screw-plug 3 mounted as shown in the outer end of said casting and closing said chamber 4 and provided with an outlet port or channel 4<sup>1</sup>, and an exhaust valve 3<sup>1</sup> mounted in said plug 3 and arranged in said chamber 4 and adapted to afford a means for cleaning the ignition tube at each explosion of the products of combustion therein, all substantially as described. 7th. In a gas engine attachment, an automatic ventilating valve for the ignition tube interposed between the said tube and the explosive chamber and so arranged as to be opened by suction at each discharge of the explosive fuel for the purpose of clearing the said tube of the products of combustion, substantially as described. 8th. In a gas engine attachment, a spring-pressed feed-valve having a pendant extended stem mounted as shown in the vaporizing shell and provided upon its upper end with a bell-shaped plate 16 adapted to admit the fuel oil to the vaporizing chamber as desired, all substantially as described. 9th. In a gas engine attachment, a cylinder having an inner bore carrying a working piston, thereby forming an explosion chamber, a surrounding space having an inlet and outlet pipe connection adapted to contain a small quantity of water for the purpose of maintaining a safe working temperature in said bore, an end adapted for the reception of the working piston and to be secured in any proper manner to or cast with the main frame of engine, and an end nearly closed in such manner as to avoid any communication between the inner bore and the water space by the use of packing-joint or otherwise, all substantially as set forth and described.

**No. 57,313. Machine for Tracing and Shaping Boots and shoes. (Machine à former et tailler les chaussures.)**

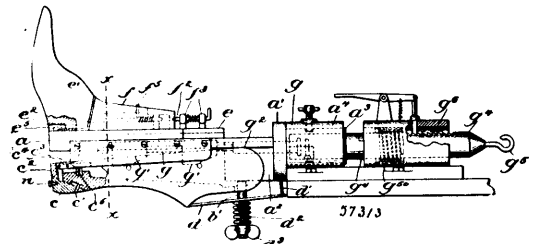

George Henry Clark, Boston, Mass., U.S.A., 3rd September, 1897; 6 years. (Filed 19th July, 1897.)

*Claim.*—1st. In a shaping machine for boots and shoes, an expandible form having a detachable fore-part and an independent detachable shin piece. 2nd. In a shaping machine for boots and shoes, an expandible form having an independent detachable shin piece and a fore-part detachably connected thereto. 3rd. In a machine for tracing or shaping boots and shoes, an expandible form having a slide, a fore-part and a shin piece made independent of each other, and separately detachable from the slide to which they are connected, substantially as described. 4th. In a machine for tracing or shaping boots and shoes, an expandible form having a detachable shin piece, and a detachable fore-part abutting against said shin piece, said parts being made independent of each other, and separately detach-

able, substantially as described. 5th. In a machine for treeing or shaping boots and shoes, an expansible form having a slide, a shin piece detachably connected thereto, an independently detachable fore-part made separate and independent of said shin piece, and means for connecting its rear end to the slide and means for connecting its upper end to the shin piece, substantially as described. 6th. In a machine for treeing or shaping boots and shoes, a form having a heel piece sliding obliquely on the rear side of the back leg part in a direction toward the shank, substantially as described. 7th. In a machine for treeing or shaping boots and shoes, an expansible form having a heel piece sliding obliquely on the rear side of the back leg part in a direction toward the shank, and a locking device therefor, substantially as described. 8th. In a machine for treeing or shaping boots and shoes, an expansible form having a heel piece sliding obliquely on the rear side of the back leg part in a direction toward the shank, and an automatic locking device therefor, substantially as described. 9th. In a machine for treeing or shaping boots and shoes, an expansible form having a heel piece sliding obliquely on the back leg part, a locking device therefor, means for operating said locking device to lock the sliding heel piece when the parts are separated, and means for operating said locking device to unlock the sliding heel piece when the parts close together, substantially as described. 10th. In a machine for treeing or shaping boots and shoes, an expansible form having a heel piece sliding obliquely on the back leg part, a pivoted locking lever for said sliding heel piece, spring for moving it into locking position, and a projection on one member of the form for operating said locking lever when the parts thereof close together, substantially as described. 11th. In a machine for treeing or shaping boots and shoes, an expansible form having a sliding fore-part, and a sliding heel piece, the latter sliding obliquely on its support, substantially as described. 12th. In a machine for treeing or shaping boots and shoes, an expansible form, having a fore-part and a heel, and a plate on the bottom of said heel, adjustable towards and from the heel, substantially as described. 13th. In a machine for treeing or shaping boots and shoes, an expansible form, having a rotatable frame provided with a pin having a screw threaded end, a back leg portion having at its upper end a hole for said pin, a plate bearing at one end upon the back leg part, and at the other end upon the rotatable frame, a spring encircling said pin and bearing upon said plate, and a nut turning on the pin and acting on said spring, substantially as described. 14th. The detachable fore-part  $c^1$ , having at its rear side the recess  $c^2$ , and in its top a hole, and the back plate  $c^3$ , bent angularly and shaped to fit the rear and top sides of said fore-part, it having a hole in the top part, and a slot  $c^4$ , in its rear part, the slotted end portion of said plate partially covering the recess  $c^2$ , and thereby forming a socket to receive a headed stud, substantially as described. 15th. In a machine for treeing or shaping boots and shoes, a shin piece, a detachable fore-part, a fastening for the rear end of said fore-part, and a spring actuated locking pin for the top of said fore-part which passes through said shin piece, substantially as described.

#### No. 57,314. Veterinary Obstetrical Forceps.

(Forceps.)

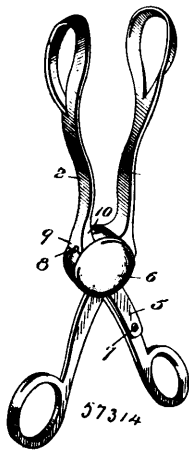

Gerhard B. Ostlick, Neola, Iowa, U.S.A., 3rd September, 1897; 6 years. (Filed 19th July, 1897.)

*Claim.*—1st. Forceps, having separate members, adapted to be overlapped at their fulcrum-points, and provided respectively with a fulcrum pin and an opening adapted to receive said pin, the pin being adapted to extend through to the outer surface of the member having the opening, and a securing-plate or latch pivotally mounted upon the member carrying the fulcrum-pin, and adapted to be terminally arranged over the member having the opening to bear upon the extremity of said fulcrum-pin, whereby detachment of the members is prevented, except when the securing-plate or latch is

deflected to remove its free extremity from engagement with said fulcrum-pin, substantially as specified. 2nd. Forceps, having separate members adapted to be overlapped at their fulcrum-points, and provided respectively with a fulcrum-pin and an opening to receive said pin, and a securing-plate or latch pivotally mounted upon the member carrying the fulcrum-pin, and adapted to be arranged over the member having the opening to bear upon the extremity of the fulcrum-pin, said securing-plate or latch being provided at its free end with a reduced extension to fit in a seat in a contiguous enlargement or shoulder of the member which carries the fulcrum-pin, substantially as specified.

#### No. 57,315. Punching Bag. (Sac à boxe.)

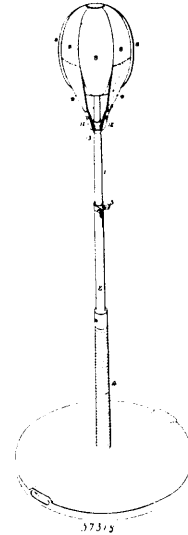

Ellsworth Adam Hawthorne, Philadelphia, and Horace Sheble, Melrose, both in Pennsylvania, U.S.A., 4th September, 1897; 6 years. (Filed 20th July, 1897.)

*Claim.*—1st. The combination of a punching bag, with a supporting rod or standard upon which said bag is mounted, so that it is retained vertically, but is free to turn or spin around upon the supporting rod when a side-blow is delivered upon it. 2nd. The combination of the supporting rod or standard, the bag, a shoe to which said bag is confined so as to be incapable of rotation thereon, said shoe being rotatably mounted on the upper end of the supporting rod, and means for vertically confining the bag and its shoe to said rod, substantially as specified. 3rd. The combination of a punching bag and a supporting rod therefor, with a rotatable shoe mounted upon the upper end of the supporting rod, and serving as a seat for the bag, a rotatable disc on the rod, and means for confining the bag to said rotatable disc, substantially as specified. 4th. The combination of a punching bag, the supporting rod or standard, the rotatable shoe serving as a support for the bag, a disc rotatable on the standard, straps or tabs depending from the bag, and means for securing said straps or tabs to the rotatable disc, substantially as specified. 5th. The combination of a punching bag, a supporting rod or standard therefor, a collar secured to said standard and having a projecting rib, a disc free to turn around the collar and having a bearing against said rib, tabs depending from the bag, and means for securing said tabs to said disc, substantially as specified. 6th. The combination of a punching bag, a supporting rod or standard therefor, a disc vertically confined on said standard, but free to rotate thereon, and tabs depending from the casing of the punching bag and secured to said disc, said tabs being formed by the outer portions of sections of the bag casing, substantially as specified.

#### No. 57,316. Oil Dispensing Apparatus.

(Appareil à distribuer l'huile.)

R. D. Guthrie, York, State of New York, U.S.A., 4th September, 1897; 6 years. (Filed 20th July, 1897.)

*Claim.*—1st. In a liquid-dispensing apparatus, the combination with the discharge spout, of the two measuring chambers, the movable double funnel beneath the spout, the discharge pipes H, H<sup>1</sup>, leading from the chambers, and the passage K, the rotary three-way valve controlling said passages and pipes, and connections between the valve and double funnel for causing their simultaneous operation in opposite directions, whereby when the spout is discharging into one chamber, the discharge pipe from said chamber is closed, substantially as described. 2nd. The combination with the tank, and the pump having the discharge spout, of the two measuring chambers having the overflows leading to the tank, the movable

double funnel beneath the pump spout, the discharge passages from the measuring chambers, a valve controlling the discharge passages

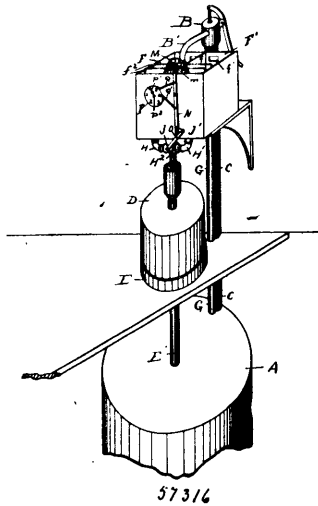

from the measuring chambers, and connections, substantially as described, between it and the double funnel, whereby liquid is conducted into one measuring chamber, while it is being discharged from the other, and a counter actuated by the movement of the valve, substantially as described. 3rd. The combination with the discharge spout, of the measuring chambers having the overflows, the double funnel beneath the spout, the discharge passages from the chambers, the valve for controlling said passages, the pivoted lever connected to the valve and the double funnel, substantially as described. 4th. The combination with the tank and the pump having the discharge spouts of the measuring chambers having overflows leading to the tank, the double funnel beneath the spout, the discharge passages from the chambers, the three-way valve for controlling them, connections between the double funnel and valve, the telescoping conduit, the drip-pan and the pipe connecting it with the tank, substantially as described.

**No. 57,317. Dry Air Freezer. (Réfrigérateur à air.)**

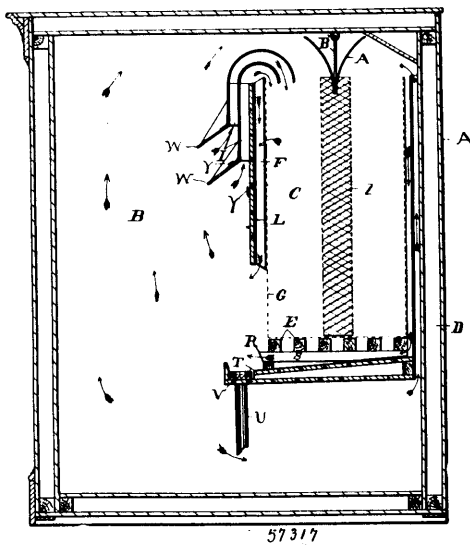

Frank W. Merrill, Scarborough, Maine, U.S.A., and John A. Rafter, Montreal, Quebec, Canada, 4th September, 1897; 6 years. (Filed 21st July, 1897.)

*Claim.*—1st. In a dry air freezer, a suitable chamber, an ice bunker located therein and formed by a series of vertical studs, a wire netting covering the interior of said studs and the bottom of the bunker, a metal sheathing covering the outside of said studding, cold air flues between the back of the containing case and said sheathing, warm air flues arranged at the front of the bunker curved at the top and

overhanging the top of the bunker, substantially as described. 2nd. In a dry air freezer, a suitable chamber, an ice bunker located therein and formed by a series of vertical studs, a wire netting covering the interior of said studs and the bottom of the bunker, a metal sheathing on the outside of said studding, cold air flues between the netting and sheathing, warm air flues between the back of the containing case and said metal sheathing and force flues arranged at the front of the bunker curved at the top and overhanging the top of the bunker and means for regulating the size of the lower end of the force flues, substantially as described. 3rd. In a dry air freezer, a suitable chamber, an ice bunker located therein and formed by a series of vertical studs, a wire netting covering the interior of said studs and the bottom of the bunker, a metal sheathing covering the outside of said studding cold air flues between the netting and sheathing, warm air flues between the back of the containing case and said metal sheathing, force flues arranged at the front of the bunker and supplemental cold air flues adapted to be suspended to the top of the chamber and to extend down through the ice bunker at or near the centre thereof, substantially as described.

**No. 57,318. Floating Fish Trap or Weir. (L'ége et nasse à poisson.)**

(L'ége et nasse à poisson.)

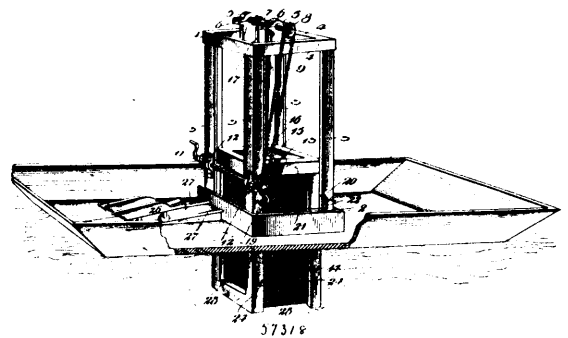

George William Nelson, Five Forks, Pennsylvania, U.S.A., 4th September, 1897; 6 years. (Filed 22nd July, 1897.)

*Claim.*—1st. A floating fish trap or weir, comprising the vessel 1 provided with the rectangular well hole 2, the right-angular guide standards 3 3 connected by the braces 4 4, the uprights 5 5 secured to said braces, the shaft 7 journaled in said uprights and provided with the flexible cords 17 and the sprocket-wheel 8, the sprocket-chain 9, the shaft 11, its sprocket and ratchet-wheels, pawl and operating handles, in combination with the rectangular cage 14, the detents 24 24 secured to said cage, the pawls 19 and 20 pivoted to said standards and connected by the rod 21, substantially as and for the purpose set forth. 2nd. A floating fish trap, comprising the vessel 1, provided with the inclined rails 27 and the rectangular well hole 2, the right-angular guide standards 3 3 connected by the braces 4 4, the uprights 5 5 secured to the said braces, the shaft 7 journaled in said uprights and provided with the screw eyes and flexible cord, the sprocket-wheel 8, the sprocket-chain 9, the shaft 11, its sprocket-wheel 10, and means for operating the same, in combination with the rectangular cage, the detents 25 secured thereto, the pawls 19 and 20 pivoted to the standards in the path of said detents and connected by the rod 21 and the travelling car 26, substantially as shown and described.

**No. 57,319. Speed Regulator for Gas and Petroleum Motors. (Régulateur de vitesse pour machines à gaz ou pétrole.)**

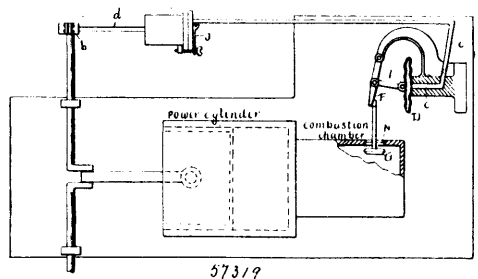

Emil Capitaine, Frankfort-on-the-Main, Germany, 4th September, 1897; 6 years. (Filed 30th July, 1897.)

*Claim.*—1st. A speed-regulating mechanism for gas and petroleum engines, comprising a piston cylinder, a piston therein operatively

connected with the crank-shaft of the engine, said cylinder having a rear valve port, a valve for controlling said port, a spring acting upon said valve to normally hold it open or partially so, to admit air to said cylinder, and means operated by a variation of air-pressure in said cylinder and operating to control a supply or exhaust port of the engine, substantially as specified. 2nd. In a speed-regulating mechanism for gas and petroleum engines, the combination with the piston cylinder A, having piston *a* and rod *d*, the latter actuated by an eccentric *b* on the crankshaft of the engine, port *i*, hinged flap-valve *J* adjusting screw *H*, a spring *S*, and air conduit a communicating with the piston cylinder, and means actuated by the air-pressure created thereby and operating to open or close the exhaust-valve or fuel supply ports of the engine, substantially as described. 3rd. In speed-governing devices for engines of the character described, the combination with a piston cylinder having a rear valve port, a valve which controls said port, and adapted under normal conditions to admit air therethrough and to be closed by a reduction of air-pressure in said cylinder, and a piston in said cylinder operatively connected with the crankshaft of the engine, of a valve which controls a supply or exhaust port of the engine, a locking lever arranged to engage the stem of said valve to prevent its operation, a diaphragm connected to said lever, and an air-conduit leading from the cylinder to the said diaphragm, substantially as specified.

**No. 57,320. Gate Latch.** (*Loquet de barrière.*)

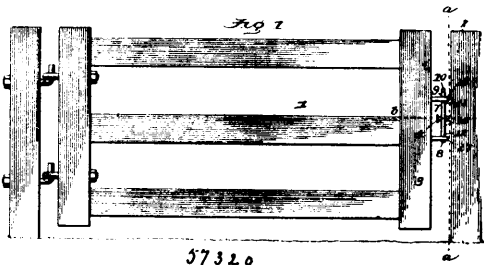

57320

Solon Owen Campbell, East Peru, Iowa, and Hugh Morrison, Savannah, Missouri, both in the U.S.A., 4th September, 1897; 6 years. (Filed 9th August, 1897.)

*Claim.*—1st. The gate provided with the brackets 15, 17, the open latch-link 7 vertically swivelled in the outer ends of said brackets, in combination with the stationary post 2, and the horizontal keeper 4, located in the path of said latch-link 7, substantially as and for the purpose set forth. 2nd. The gate 1, the bracket 15 provided with a vertical guide orifice 16, the bracket 17, provided with a guide orifice 13, located in the same vertical plane with the guide orifice 16 in the bracket 15, and having a concentric countersunk face formed with diametrical recesses 20 and 21, in combination with the open latch-link 7, the semi-circular lower end 12 of which is provided with an integral depending stud 8 engaging the guide orifice 18 in the bracket 17, the said lower end 12 of the latch-link arranged to alternately engage the diametrical recesses 20, 21 in said countersunk face of the bracket 17, the upper end of the said latch-link being formed with an integral vertical stud 9, passing through the guide orifice 16 in the bracket 15, and terminating in a laterally curved handle 10, and the fixed keeper 4 located in the path of the latch-link 7, substantially as and for the purpose set forth.

**No. 57,321. Lubricator.** (*Lubricateur.*)

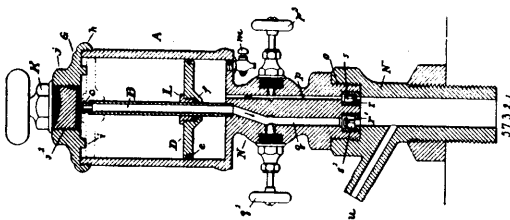

57321

Albert Dallis Howard and Conrad J. Miller, both of Massillon, Ohio, U.S.A., 4th September, 1897; 6 years. (Filed 12th August, 1897.)

*Claim.*—1st. In a lubricator for flake graphite, the combination of a closed cup; a stationary feed tube secured in the cup; a piston fitting in the cup and also around the said feed tube, and forming a space above the piston for the lubricant material and a space below the piston for steam; a stem below the said cup and having a steam passage communicating with the said space below the piston and

provided with a check-valve to prevent the back movement of the steam, and a lubricant outlet passage from the lower end of said feed-tube and provided with a check-valve to prevent steam passing into said graphite space, as set forth. 2nd. In a lubricator for flake graphite, the combination of a closed cup; a stationary feed-tube secured in the cup; a piston fitting in the cup and also around said feed-tube, and forming a space above the piston for the lubricant material and a space below the piston for steam; a steam passage to supply steam below the piston, and force said piston and the lubricant upward; a lubricant outlet passage connected with the lower end of said feed-tube; and a check-valve in said lubricant outlet passage, which is closed by pressure of steam.

**No. 57,322. Apparatus for Pumping Liquid by Fluid Pressure.** (*Appareil pour pomper les liquides au moyen de pression hydraulique.*)

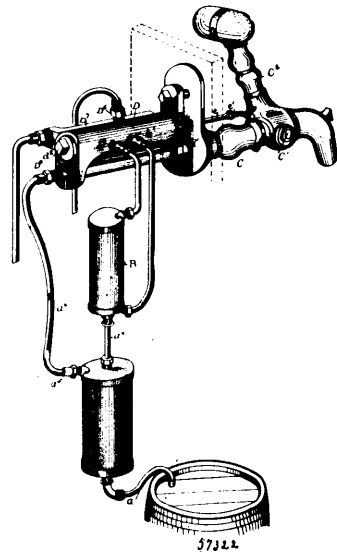

57322

The Berner-Mayer Co., Cleveland, Ohio, U.S.A., 4th September 1897; 6 years. (Filed 12th August, 1897.)

*Claim.*—1st. In apparatus for pumping liquids by fluid pressure, the combination with a pump cylinder and a motor cylinder, a piston in each of said cylinders and connected to reciprocate one with the other, and distributing passages for admitting and exhausting the actuating fluid to reciprocate said pistons, of a faucet connected to the pump cylinder and provided with a controlling plug having a handle, a valve casing formed with inlet and waste passages and having the fluid distributing passages entering it, and a valve in said casing and connected to the plug to be actuated by the same and constructed to connect the distributing passages to the inlet and waste passages, substantially as set forth. 2nd. In apparatus for pumping liquids by fluid pressure, the combination with a pump cylinder, a motor cylinder having a distributing passage at each end, and a piston in each of said cylinders and connected to reciprocate one with the other, of a faucet connected to the pump cylinder and provided with a controlling plug having a handle, a valve casing having fluid inlet and waste and having the distributing passages entering it, and a valve in said casing and connected to the plug to be actuated by the same and constructed to alternately connect each distributing passage to the inlet and waste, substantially as set forth. 3rd. In apparatus for pumping liquids by fluid pressure, the combination with a pump cylinder, a motor cylinder having a distributing passage at each end, and a piston in each of said cylinders and connected to reciprocate one with the other, of a faucet connected to the pump cylinder and provided with a controlling plug having a handle, a valve casing formed with an inlet port at its middle and waste ports at its ends and having the distributing passages entering ports one at each side of the inlet port, and a valve sliding in the valve casing and shaped to alternately connect the inlet port with one distributing port and to uncover the other distributing port to the waste and connected to the plug handle to be actuated by the same, substantially as set forth.

**No. 57,323. Faucet Coupling.** (*Joint de robinet.*)

The Berner-Mayer Company, Cleveland, Ohio, U.S.A., 4th September, 1897; 6 years. (Filed 12th August, 1897.)

*Claim.*—1st. The combination of a faucet having a number of liquid passages and formed with a face at the rear ends of said passages and having a yoke at the rear end straddling such face and forming a transverse slot, a coupling block shaped to be inserted

through said slot and having passages which register with the faucet passages and have nipples at the ends of the block and also having a

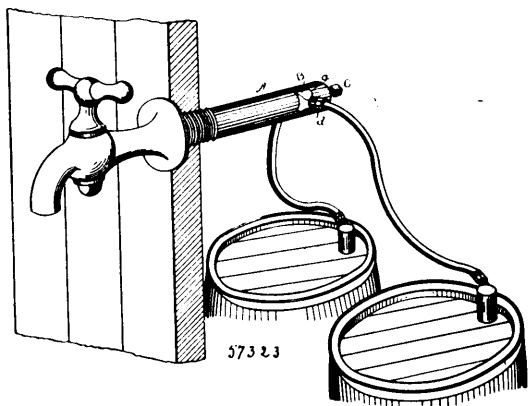

recess in its forward face fitting over the face of the faucet, a packing in said recess, and means for clamping the recessed and packed face of the block against the rear face of the faucet, substantially as set forth. 2nd. The combination of a faucet having a number of liquid passages and formed with a face at the rear ends of said passages and having a yoke at the rear end straddling such face and forming a transverse slot, a coupling block shaped to be inserted through said slot and having passages which register with the faucet passages and have nipples at the ends of the block and also having a recess in its forward face fitting over the face of the faucet, and a recess in its rear face, a packing in the forward recess, and a screw threaded through the yoke at the rear side of the slot and having its end bearing into the recess in the rear face of the block, substantially as set forth.

**No. 57,324. Rubber Hose.** (*Boyaux de caoutchouc.*)

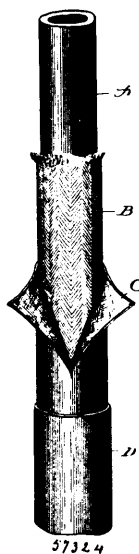

Henry Boswell Cobb, Wilmington, Delaware, and Edward Thomas Davis, Philadelphia, Pennsylvania, both in the U.S.A., 4th September, 1897; 6 years. (Filed 12th August, 1897.)

*Claim.*—1st. The method of manufacturing rubber hose, which consists in forming about a tube of alternate layers of rubber and fabric an inelastic mould and maintaining inside the tubing a counter-pressure of expansible fluid during the moulding operation, then subjecting the mould-covered product to vulcanization and finally removing the mould. 2nd. The method of manufacturing rubber hose, which consists in moulding about a tube of alternate layers of rubber and fabric a covering of lead and maintaining inside the tubing a counter-pressure of expansible fluid during the moulding operation, then subjecting the lead-covered product to vulcanization and finally removing the lead covering. 3rd. The method of manufacturing rubber hose, which consists in forming about a tube

of alternate layers of rubber and fabric an inelastic mould and maintaining inside the tubing a counter-pressure of expansible fluid during the moulding operation, then subjecting the mould-covered product to heat and finally removing the mould. 4th. The method of manufacturing rubber hose, which consists in moulding about a tube of alternate layers of rubber and fabric a covering of lead and maintaining inside the tubing a counter-pressure of expansible fluid during the moulding operation, then subjecting the lead-covered product to heat and finally removing the lead-covering. 5th. The method of manufacturing rubber hose, which consists in making rubber tubing by forcing rubber, prepared for vulcanization, through tube-forming dies, forming about said tubing an open-work covering, then encasing said covered tubing in unvulcanized rubber, forming about the whole an inelastic mould, and maintaining inside the tubing, during the moulding operation, a counter-pressure of expansible fluid, then subjecting the mould-covered product to vulcanization and finally removing the mould, substantially as described. 6th. The method of manufacturing rubber hose, which consists in making rubber tubing by forcing rubber, prepared for vulcanization, through tube-forming dies, forming about said tubing an open-work covering and covering it with sheet-rubber, then moulding about the whole a covering of lead, and maintaining inside the tubing, during the moulding operation, a counter-pressure of expansible fluid, subjecting the lead-covered product to vulcanization and finally removing the lead-covering, substantially as described. 7th. The method of manufacturing rubber hose, which consists in forming about unvulcanized rubber tubing an open-work covering, then encasing said covered tubing in unvulcanized rubber, moulding about the whole a covering of lead and maintaining inside the tubing a counter-pressure of expansible fluid during the moulding operation, then subjecting the lead-covered product to vulcanization and finally removing the lead-covering, substantially as described. 8th. In the manufacture of rubber hose composed of alternate layers of rubber and fabric, the method of forming a tubular layer of the rubber, which consists in passing sheet-rubber through a former and uniting the edges of the rubber sheet by heat, while so forming it into tubing. 9th. A step in the art of manufacturing rubber hose which consists in forming about a tube of alternate layers of rubber and fabric an inelastic mould, and maintaining during the moulding operation a counter-pressure of expansible fluid.

**No. 57,325. Self-Adjusting Reclining Chair.**  
(*Fauteuil à la voltaire.*)

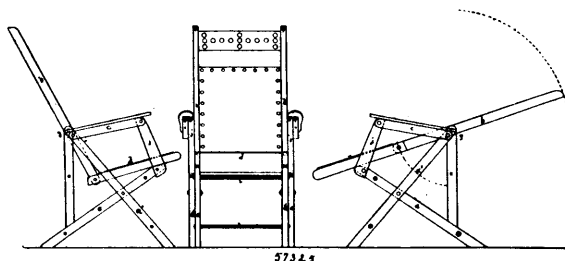

Thomas W. A. Lindsay and Hiram F. Rankin, both of Ottawa, Ontario, Canada, 4th September, 1897; 6 years. (Filed 16th August, 1897.)

*Claim.*—1st. A reclining chair, having crossed legged sides and a back pivoted thereto, a seat hinged to said back and bearing upon the ends of two cross legs and sliding thereon when the back moves, as set forth. 2nd. A reclining chair, having crossed legs at opposite sides connected by bars or stretchers, arm-rests and vertical struts secured to said legs, a back and seat hinged together, the back pivoted to the sides of the chair and the seat resting on the end of the legs or other suitable bearing, substantially as set forth. 3rd. A chair, having crossed leg sides, a back pivoted thereto, a seat hinged to the back and arm rests connected to the legs, the back and seat tilting to alignment to form a bed or couch, as set forth. 4th. A reclining chair, having a tilting back pivoted to the sides and composed of crossed legs and struts, a seat hinged to the lower edge of the back and bearing on a support at the front of said sides, said seat and back having simultaneous adjustment, substantially as set forth.

**No. 57,326. Machine for Packing Decorative Films.**  
(*Machine pour emballer les pellicules décoratives.*)

Walter Hamilton Coe, Providence, Rhode Island, U.S.A., 4th September, 1897; 6 years. (Filed 12th July, 1897.)

*Claim.*—1st. In a machine for winding decorative films into a package-roll, the combination with means for drawing the strip forward, of the pressing-roller, the table for holding the decorative films, and means for automatically causing the lapping contact of the decorative films upon the strip, substantially as described. 2nd. In a machine for winding decorative films into a package-roll, the combination with means for winding up the strip and film in a

package-roll, of a bar of wax or other suitable material, in contact with which the strip is drawn to receive a coating adapted to secure

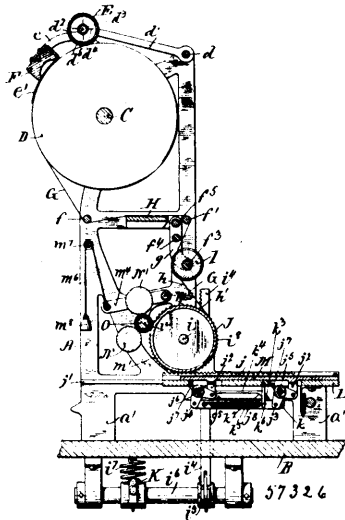

the proper adhesion of the film to the strip, and means for applying the film to the strip, substantially as described. 3rd. In a machine for winding decorative films into a package-roll, the combination with means for drawing the strip forward, of a pad for spreading the powder upon one side of the strip, and a bar of wax or other suitable material, in contact with which the strip is drawn to receive a coating upon the opposite side of the strip, which is adapted to secure the proper adhesion of the decorative film thereto, substantially as described. 4th. In a machine for winding decorative films into a package-roll, the combination with the pressing-roller, the table for supporting the films, and means for automatically lapping the films upon the strip, of the stationary roller, and the movable roller, adapted to hold the winding package in contact with the pressing roller and the stationary roller, substantially as described. 5th. In a machine for winding decorative films into a package-roll, the combination with the pressing-roller, the table for supporting the films, and the movable bed for carrying the table, of the bell-crank levers and the link connecting the table with the bed, the spring for actuating the bell-crank levers in one direction, the loose bell-crank lever connected with the spring, and the latch-cam for actuating the loose bell-crank lever to raise the table, substantially as described.

**No. 57,327. Fly Trap.** (*Altrape-monche.*)

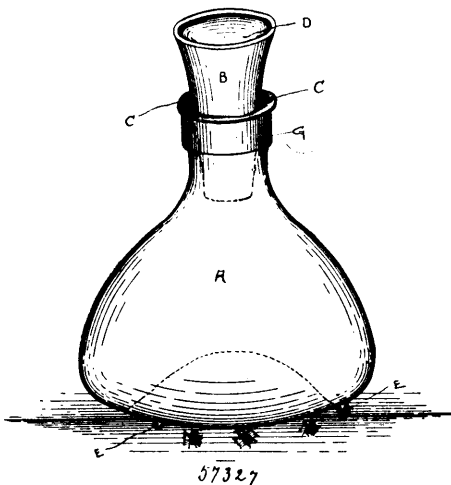

Nicholaus Renner, Elmhurst, Illinois, U.S.A., 4th September, 1897 6 years. (Filed 26th July, 1897.)

*Claim.*—1st. In an insect trap, a hollow vessel A having a tapering neck and an opening C in said neck, an opening in its under sides, legs or supports E, and means for closing the opening C, substantially as described. 2nd. In an insect trap, a transparent globe having supporting legs E, concave opening F between said

legs an opening C at its upper end, and a band or collar X around the upper end of said bowl, substantially as described. 3rd. In a combined fly trap and flower holder, a hollow vessel having supporting legs, an opening at its under side, a tapering neck, leaving an opening at its upper end, a hollow vessel of such dimensions as will wedge into the opening at its under side, and completely block said opening, substantially as described.

**No. 57,328. Mouth-piece for Pipes.** (*Ambre de pipes.*)

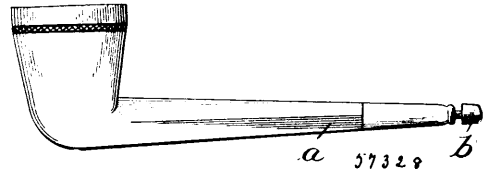

David Blair Kinch, Pittsburg, Pennsylvania, U.S.A., 4th September, 1897; 6 years. (Filed 6th July, 1897.)

*Claim.*—1st. An attachment for pipes to interrupt the flow of smoke and prevent burning of the tongue, comprising a tube adapted to fit into the mouth-piece, a spider thereon having arms radiating from the tube, the ends of said arms being screw threaded, and the cup secured to the said spider by the screw threads whereby the smoke is drawn through the outer end of the tube into the cup and escapes between the arms of the spider, substantially as described. 2nd. An attachment for pipes comprising a tube adapted to fit into the mouth-piece, a spider having arms, a cup secured thereto, and a stop on the arms, substantially as described.

**No. 57,329. Street Lamp.** (*Lampe de rue.*)

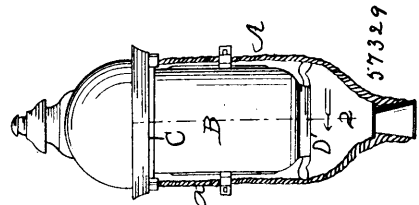

John Stewart, Chicago, Illinois, U.S.A., 4th September, 1897; 6 years. (Filed 19th July, 1897.)

*Claim.*—1st. In a lamp, the combination of an outside frame provided with clips or cleats at its sides and a removable flanged ring in its upper portion, and a globe formed of vertical sections having outwardly-projecting flanges at their edges fitting into the clips or cleats of the frame, whereby the sections are secured and held together, and an outwardly-projecting flanges at the top fitting over and resting upon the flanged ring of the frame, whereby the globe is adapted to be inserted in the frame and held in position vertically, substantially as described.

**No. 57,330. Carpenter's Gauge.** (*Jauge de charpentiers.*)

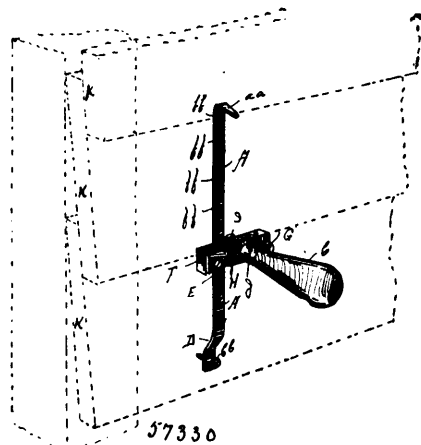

John A. Ratcliff, Columbus, Kansas, U.S.A., 4th September, 1897; 6 years. (Filed 23rd July, 1897.)

*Claim.*—1st. A weather board gauge provided with a bar having a right-angled projection at its upper end, a projection on the



opposite side of the bar, and at its lower end of a depth equal to the thickness of the weather-board and having an extension in a plane parallel to the plane of the bar and provided with a screw, in combination with a horizontal block adjustable on said bar and provided with an awl and a clamping-screw. 2nd. A weather board guage provided with a bar and a block adjustable thereon, in combination with an awl extending through said block and provided with a flange axially revoluble and adjacent the inner surface of the block.

**No. 57,331. Rotary Machine. (Machine rotative.)**

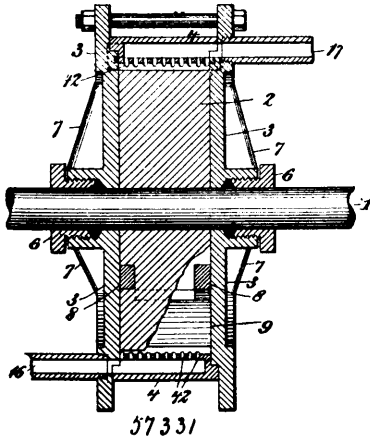

George Bohan Shephard, Ogdensburg, New York, U.S.A., 4th September, 1897; 18 years. (Filed 20th July, 1897.)

*Claim.*—1st. In a rotary device, the combination of two parts, one encircling the other, and one adapted to revolve with reference to the other, one part being provided with a cam surface having raised portions concentric with the axis of rotation and depressed portions concentric with said axis, and the other part having a surface concentric in part or in whole with the axis of rotation and a double-headed curved gate carried by one of the parts and having bearing surfaces at or near both ends, and inclined portions either on the cam surface or on the ends of the gate, the ends of the gate being in contact with the cam surface all of the time so that the cam surface moves the gate back and forth, and suitable inlet and outlet ports, substantially as shown and described. 2nd. In a rotary device, the combination of two parts, one encircling the other, and one adapted to revolve with reference to the other, one part being provided with a cam surface having raised portions concentric with the axis of rotation and depressed portions concentric with said axis, said concentric portions being of substantially equal arc and at an equal distance from one another, and inclined portions connecting the concentric portions, and the other part having a surface in part or in whole concentric with the axis of rotation, and two or more double-headed gates having bearing surfaces at or near both ends which are in contact with the cam surface all of the time so that the cam surface moves the gates back and forth, and suitable inlet and outlet ports, substantially as shown and described. 3rd. In the rotary device, the combination of two parts, one encircling the other and one adapted to revolve with reference to the other, one part being provided with a cam surface having raised portions concentric with the axis of rotation and depressed portions concentric with said axis, and the other part having a surface concentric in part or in whole with the axis of rotation and provided with interior slots to hold and guide the gates, and double-headed curved gates sliding in said slots and having bearing surfaces at or near both ends, and inclined portions either on the cam surface or on the ends of the gates, the ends of the gates being in contact with the cam surface all of the time so that the cam surface moves the gates back and forth, and suitable inlet and outlet ports, substantially as shown and described. 4th. In a rotary device, the combination of two parts, one encircling the other, and one adapted to revolve with reference to the other, and having bearing surfaces at or near both ends adapted to be at all times in contact with the surface of the other part, and suitable inlet and outlet ports, substantially as set forth. 5th. In a rotary device, the combination of a drum and an encircling shell, one adapted to revolve with reference to the other, the shell being provided with an interior cam surface having raised portions concentric with the axis of rotation and depressed portions concentric with said axis, and inclined portions connecting said concentric portions, and the drum having a surface in part or in whole concentric with the axis of rotation and provided with uniformly curved slots to hold and guide the gates, and double-headed uniformly curved gates sliding in said slots and having bearing surfaces at or near both ends adapted to be in contact all the time with the cam surface, and suitable inlet and outlet ports, substantially as set forth. 6th. In a rotary device, the combination of a drum and an encircling shell, one

adapted to revolve with reference to the other, one being provided with a suitable cam surface and the other having a surface in part or in whole concentric with the axis of rotation and provided with interior uniformly curved slots to hold and guide the gates and double-headed uniformly curved gates sliding in said slots and having bearing surfaces at or near both ends adapted to be in contact all the time with different parts of the cam surface, substantially as set forth. 7th. In a rotary device, the combination of the drum 2 having a surface concentric with the axis of rotation, the shell 3, 3, 4, having a cam surface as described, the curved gates 9 adapted to bear at all times at both ends against the cam surface, the inlet ports 16, 16, and the outlet ports 17, 17, substantially as set forth. 8th. In a compound rotary device, the combination of a primary consisting of two parts, one encircling the other, one adapted to revolve with reference to the other, one being provided with a cam surface having raised portions concentric with the axis of rotation and depressed portions concentric with said axis, said concentric portions being of substantially equal arc and at an equal distance from one another, and inclined portions connecting the concentric portions, and the other part having a surface in part or in whole concentric with the axis of rotation, and two or more double-headed curved gates having bearing surfaces at or near both ends adapted to be in contact with the cam surface all of the time so that the cam surface moves the gates back and forth, and suitable inlet and outlet ports, and a secondary consisting of similar parts similarly constructed and arranged, the inlet port of the secondary being connected in line with the outlet port of the primary, substantially as shown and described. 9th. In a rotary device, the combination of two parts, one encircling the other, one adapted to revolve with reference to the other, and a double-headed curved gate carried by one of the parts and having bearing surfaces at or near both ends adapted to be at all times in contact with the surface of the other part, and suitable inlet and outlet ports staggered with reference to one another, substantially as set forth.

**No. 57,332. Clamp. (Crampon.)**

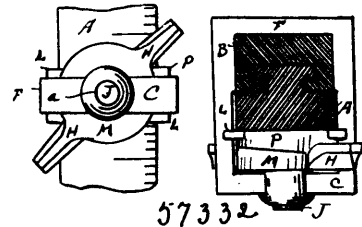

Charles F. Wilson, Ottawa, Illinois, U.S.A., 4th September, 1897; 6 years. (Filed 26th July, 1897.)

*Claim.*—1st. The combination, with a levelling-rod comprising two or more longitudinal sections, adapted to move lengthwise with respect to each other, of the clamp mounted on the rod and connected to one of the sections thereof, and adapted to adjustably fix the sections with respect to each other, the said clamp comprising a frame, a member carried by and permanently connected to and inmovable with respect to the frame, and having a circular inclined plane upon one of its faces, and a rotatable or partially rotatable member having a circular inclined plane upon its face, contiguous to the first-named member, adapted to impinge against the inclined plane of said member and also having a trunnion journaled in one of the bars of the frame, substantially as described. 2nd. The combination, with a levelling rod comprising two or more longitudinal sections, adapted to move lengthwise with respect to each other, and a target, of a clamp mounted on the rod, and connected to one of the sections thereof and adapted to adjustably fix the said sections with respect to each other, the said clamp comprising a frame connected to the target, a member carried by and permanently connected to and inmovable with respect to the frame, and having a circular inclined plane upon one of its faces, and a rotatable or partially rotatable member having a circular inclined plane upon its face, contiguous to the first named member, adapted to impinge against the inclined plane of said member, and also having a trunnion journaled in one of the bars of the frame, substantially as specified.

**No. 57,333. Coin Actuated Delivery Apparatus.**

(Appareil actionné par une pièce de monnaie pour distribuer des objets.)

Edward Julius Brandt, Watertown, Wisconsin, U.S.A., 4th September, 1897; 6 years. (Filed 26th July, 1897.)

*Claim.*—1st. A coin-delivery apparatus comprising a suitable casing, a series of inclined coin-chutes in the casing, a notched plate at the lower ends of the chutes constituting a temporary stop for the coin, a coin-follower in each of said chutes, suitably arranged spring-controlled drums in flexible strap-connection with the coin-followers, and pusher-mechanism operative to lift coin from the chutes into register with notches of the aforesaid plate, these notches being of such contour and dimension as will permit escape of the lifted coin. 2nd. A coin-delivery apparatus comprising a suitable casing, a

series of inclined coin-chutes in the casing, a notched plate at the lower ends of the chutes constituting a temporary stop for the coin,

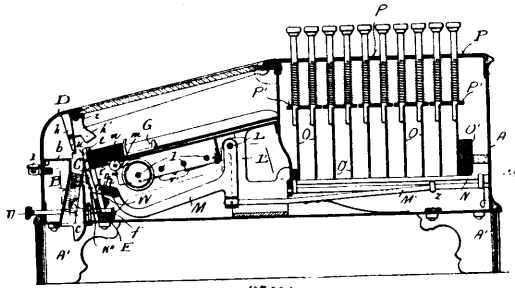

57333

a coin-follower in each of said chutes, suitably arranged spring-controlled drums in flexible strap-connection with the coin-followers, a pusher-mechanism operative to lift coin from the chutes into register with notches of the aforesaid plate, and deflectors for the lifted coin, said notches being of said contour and dimensions as will permit escape of said lifted coin. 3rd. A coin-delivery apparatus comprising a suitable casing, a series of inclined coin-chutes in the casing, a suitably notched plate at the lower ends of the chutes constituting a temporary coin-stop, a coin-follower in each of said chutes, suitably arranged spring-controlled drums in flexible strap-connection with the coin-followers, a series of lever-controlled pushers operative to eject coin from the aforesaid chutes, and lever-actuating mechanism comprising a series of rockers and a series of reciprocal edgewise plates having feet operative on the rockers. 4th. A coin-delivery apparatus comprising a suitable casing, a series of inclined coin-chutes in the casing, a suitably notched plate at the lower ends of the chutes constituting a temporary coin-stop, a delivery-chute in front of the plate, a coin-follower in each of said chutes, suitably arranged spring-controlled drums in flexible strap-connection with the coin-followers, a series of lever-controlled pushers operative to eject coin from the aforesaid chutes, and lever-actuating mechanism comprising a series of rockers and a series of reciprocal edgewise plates having feet operative on the rockers. 5th. A coin-delivery apparatus comprising a suitable casing, a series of inclined coin-chutes in the casing, a suitably notched plate at the lower ends of the chutes, constituting a temporary coin-stop, a coin-follower in each of said chutes, suitably arranged spring-controlled drums in flexible strap-connection with the coin-followers, a series of lever-controlled pushers operative to eject coin from certain of the chutes, lever-actuating mechanism comprising a series of rockers and a series of reciprocal edgewise plates having feet operative on the rockers, other lever-controlled pushers operative to eject coin from the remaining chutes of the series, and a multiple lever-and-trip mechanism operative in conjunction with the latter pushers. 6th. A coin-delivery apparatus comprising a series of inclined coin-chutes, a suitably notched plate at the lower ends of the chutes constituting a temporary coin-stop, an automatic pressure-exerting coin-follower in each of said chutes, a series of lever-controlled pushers operative to eject coin from the aforesaid chutes, lever-actuating mechanism comprising a series of rockers and a series of reciprocal edgewise plates, having feet operative on the rockers, and a locking mechanism for the levers. 7th. A coin-delivery apparatus comprising a series of inclined coin-chutes, a suitably notched plate at the lower ends of the chutes constituting a temporary coin-stop, an automatic pressure-exerting coin-follower in each of said chutes, a series of lever-controlled coin-pushers operative to eject coin from certain of the chutes, lever-actuating mechanism comprising a series of rockers and a series of reciprocal edgewise plates having feet operative on the rockers, other lever-controlled pushers operative to eject coin from the remaining chutes of the series, a multiple lever-and-trip mechanism operative in conjunction with the latter pushers, and a locking-mechanism for all the levers. 8th. A coin-delivery apparatus comprising a series of inclined coin-chutes, a suitably notched and slotted plate at the lower ends of the chutes constituting a temporary coin-stop, an automatic pressure-exerting coin-follower in each of said chutes, a series of lever-controlled, pivotally adjustable coin-pushers engaging the plate-slots, and suitable mechanism for operating single levers and combinations of levers. 9th. A coin-delivery apparatus comprising a series of inclined coin-chutes, a suitably notched and slotted plate at the lower ends of the chutes constituting a temporary coin-stop, an automatic pressure-exerting coin-follower in each of said chutes, a system of levers, coin-pushers having pivotal spring-controlled connection with the levers and engaged with the plate-slots, a spring-plate secured at one end to each coin-pusher and provided with lateral ears opposing the plate aforesaid, a set-screw adjustable in the spring-plate to bear against the corresponding coin-pusher, and suitable mechanism for operating single levers and combinations of levers. 10th. A coin-delivery apparatus comprising

a series of inclined coin-chutes, a suitably notched and slotted plate at the lower ends of the chutes constituting a temporary coin-stop, an automatic pressure-exerting coin-follower in each of said chutes, a series of lever-controlled pivotally adjustable coin-pushers engaging the plate-slots, suitable mechanism for operating single levers and combinations of levers, and a locking-mechanism for said levers. 11th. A coin-delivery apparatus comprising a series of inclined chutes, a temporary coin-stop at the lower ends of the chutes, an automatic power-exerting coin-follower in each of said chutes, a series of lever-controlled coin-pushers, suitable mechanism for operating single levers and combinations of levers, and other suitable mechanism operative to throw one or more coin-pushers of a combination out of working position. 12th. A coin-delivery apparatus comprising a series of inclined coin-chutes, a temporary coin-stop at the lower end of each chute, an automatic power-exerting coin-follower in each of said chutes, a series of spring-controlled, pivotally-adjustable coin-pushers, suitable mechanism for operating single coin-pushers and combinations of the same, and other suitable mechanism operative in conjunction with certain of said coin-pushers to throw the same out of working position. 13th. A coin-delivery apparatus comprising a series of inclined coin-chutes, a temporary coin-stop at the lower end of each chute, an automatic power-exerting coin-follower in each of said chutes, a series of spring-controlled, pivotal coin-pushers, suitable mechanism for operating single coin-pushers and combinations of the same, and spring-controlled push-pins operative in conjunction with certain of said coin-pushers to throw the same out of working position. 14th. A coin-delivery apparatus comprising a series of inclined coin-chutes, a temporary coin-stop at the lower end of each chute, chute-engaging coin-followers, flexible straps connected to the coin-followers and trained on pulleys through apertures in the chute-bottoms, spindles journaled in bearings under said chutes, loose drums on the spindles in connection with the straps, spiral-springs on said spindles connecting the latter with said drums, and suitable means for dislodging coin from the lower ends of the aforesaid chutes. 15th. A coin-delivery apparatus comprising a series of inclined coin-chutes, a temporary coin-stop at the lower end of each chute, chute-engaging coin-followers, spindles journaled in bearings under the chutes, loose drums on the spindles in flexible strap-connection with the coin-followers, spiral-springs on the spindles connecting the latter with said drums, stops for retaining said spindles in rotary adjusted positions to vary spring-tension, and suitable means for dislodging coin from the lower ends of the aforesaid chutes. 16th. A coin-delivery apparatus comprising a series of inclined coin-chutes, a temporary coin-stop at the lower end of each chute, chute-engaging power-exerting coin-followers, a fulcrum-rod, a series of levers supported on the rod, and provided with rear crank-rod extensions, a series of rockers operative on the said lever extensions, reciprocal edgewise plates having feet operative on the rockers, and pushers having pivotal spring-controlled connection with forward ends of the levers under coin in the lower ends of the aforesaid chutes. 17th. A coin-delivery apparatus comprising a series of inclined coin-chutes, a temporary coin-stop at the lower end of each chute, chute-engaging power-exerting coin-followers, a series of levers having a common fulcrum, crank-rods extended rearward from certain of the levers, rockers operative on the crank-rods, reciprocal edgewise plates having feet operative on the rockers, the remainder of the levers provided with spring-controlled rear rod-extensions, a pusher having spring-controlled pivotal connection with each lever under coin in the lower ends of the aforesaid chutes, a coin-pusher trip-device on the fulcrum-rod, and a system of multiple-levers operative in conjunction with the trip and those of the aforesaid levers provided with spring-controlled rod extensions, the working-faces of the pushers connection with the latter levers being of width approximating the thickness of a plurality of coin. 18th. A coin-delivery apparatus comprising a pair of inclined coin-chutes, a temporary coin-stop at the lower end of each chute, chute-engaging power-exerting coin-followers, levers carrying spring-controlled pivotal pushers each of which opposes two coin at the lower end of a chute, a tripper operative to bring one of the pushers out of opposition to the innermost coin normally in line therewith, and a series of four tilt-levers operative in conjunction with the tripper and aforesaid levers to effect an ejection of one, two, three or four coins from the aforesaid chutes. 19th. A coin-delivery apparatus comprising a pair of inclined coin-chutes, a temporary coin-stop at the lower end of each chute, chute-engaging power-exerting coin-followers, a pair of levers carrying spring-controlled pivotal pushers arranged to oppose two coins at the lower end of a chute, a tripper operative to bring one of these pushers out of opposition to the innermost coin normally in line therewith, a tilt-lever operative to actuate the tripper and that one of the pusher levers carrying the tripped coin-pusher, a second tilt-lever operative to actuate said pusher-lever independent of the tripper, a third tilt-lever operative to actuate said tripper and both pusher-levers, and a fourth tilt-lever operative to actuate both pusher-levers independent of the tripper. 20th. A coin-delivery apparatus comprising a suitable casing, a series of inclined chutes in the casing, a temporary coin-stop, at the lower end of each chute, chute-engaging power-exerting coin-followers, a system of levers carrying pushers operative to eject coin from said chutes, a series of lever actuating rockers, edgewise plates having feet operative on the rockers, spring-controlled push-pins connected to the plates in successive series, and a pair of suitably spaced and connected horizontal guide-plates for each series of pins,

the upper guide-plate in each pair constituting a top section of said casing. 21st. A coin-delivery apparatus comprising a series of inclined chutes, a temporary coin-stop at the lower end of each chute, chute-engaging power-exerting coin-followers, ejector-mechanisms operative on single coin and combinations of coins, and stop ears extending inward from walls of each chute in opposition to the coin next in rear of a predetermined number in position to be acted upon by ejector mechanism. 22nd. A coin-delivery apparatus comprising a series of inclined chutes, a temporary coin-stop at the lower end of each chute, chute-engaging power-exerting coin-followers, ejector-mechanisms operative on single coin and combinations of coin, and chute wall noses arranged to oppose foremost coin of each column and skew the same as it clears the temporary stop incidental to action of ejector-mechanism. 23rd. A coin-delivery apparatus comprising a series of inclined chutes, a temporary coin-stop at the lower end of each chute, chute-engaging power-exerting coin-followers, ejector-mechanisms operative on single coin and combinations of coin, stop-ears extending inward from chute-walls in opposition to the coin next in rear of a predetermined number in position to be acted upon by ejector-mechanism, and chute-wall noses arranged to oppose foremost coin of each column and skew the same as it clears the temporary stop incidental to action of ejector-mechanism. 24th. A coin-delivery apparatus comprising an inclined coin-chute, a temporary coin-stop at the lower end of the chute, a chute-engaging power-exerting coin-follower, a pivotal pusher in normal opposition to two coin in the lower end of the chute, a tripper operative to bring the pusher out of opposition to the innermost coin normally in line therewith, a spring-controlled finger arranged to resist frictional lift of the latter coin, suitable mechanism for effecting joint action of the tripper and pusher, and other suitable mechanism for actuating the pusher independent of the tripper.

**No. 57,334. Phantom Float. (Flotte fantôme.)**

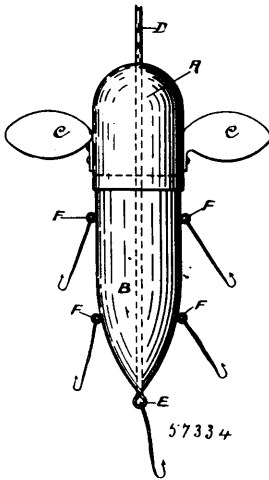

Livingston S. Hinckley, Newark, New Jersey, U.S.A., 4th September, 1897; 6 years. (Filed 27th July, 1897.)

*Claim.*—1st. A hollow aluminium body, two individually separate parts constituting the same each capable of being filled with floatable matter, a wire passing through both said parts, the upper part revolving on and the lower part attached to said wire, two or more blades or wings attached to the upper revolvable part in any suitable manner, all for the purposes as set forth substantially as it is illustrated and described. 2nd. In a hollow aluminium float of the character set forth, an upper revolvable part having two or more wings or blades attached for the purposes as set forth, a lower part furnished with eyes, a wire or cord passing through the centre of the said float, having the lower part attached thereto, and the upper part movable thereon, conforming with their touching surfaces to each other in the manner described and illustrated and for the purposes as set forth.

**No. 57,335. Tablet Machine for Stenographers' use. (Tablet pour l'usage des sténographes.)**

Millard Pinckney Bonebrake, Stockton, Kansas, U.S.A., 4th September, 1897; 6 years. (Filed 22nd May, 1897.)

*Claim.*—1st. The combination, with the frame consisting of the sides and the inclined desk-table, of the removable supply roller, the main feed roller slotted to receive the end of the paper roll, and provided with a pulley, of the elastic belt connecting said pulley with a similar pulley on the supply roller, substantially as and for

the purpose specified. 2nd. The sides 5, 6, provided with the inclined desk-table 7, and having the hinged bearing block 17, of

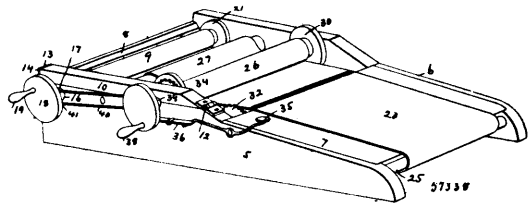

the rollers 9 and 26, and the friction rollers 25 and 27, the sheet of paper 23, and the endless belt connecting said rollers 9 and 26, substantially as and for the purpose specified. 3rd. The sides 5 and 6, and desk-table 7, the auxiliary and feed supply rollers, in combination with the paper roll 23 extending from the supply roller under and over the desk to the feed roller, substantially as and for the purpose specified. 4th. The sides 5 and 6, desk-table 7, and the sheet of paper 23, in combination with the feed roller 26 and the supply roller 9, one end of which is journaled in a bearing slot 16, having an upper removable bearing block 17, held in place by the hinged bar 10, substantially as and for the purpose specified. 5th. The combination, with the sides 5 and 6, desk-table 7, and the rollers 9 and 26, the latter provided with a gear wheel 34, of the motor 32, 33, having the thumb lever 35, substantially as and for the purpose specified.

**No. 57,336. Device for Attaching Wheels to Axles. (Appareil pour attacher une roue à son axe.)**

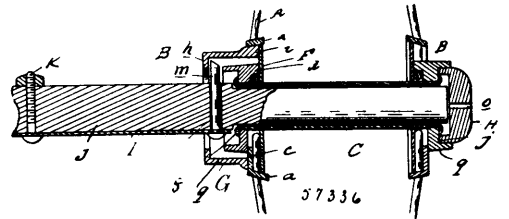

The Toledo Metal Wheel Co., assignee of Frank Southard and Frederick Newhouse, all of Toledo, Ohio, U.S.A., 4th September, 1897; 6 years. (Filed 21st August, 1897.)

*Claim.*—1st. In a device for attaching wheels to axles, the combination with the hub of the wheel, of a sand band secured to the hub and formed with an interior recess and a spring catch on the axle adapted to engage into said recess to detachably engage with and hold the wheel. 2nd. In a device for attaching wheels to axles, the combination with the hub of a wheel complete in itself of a sand band secured to the inner end of the hub and provided with an inwardly projecting flange forming an interior recess within the sand band, an axle formed with a transverse aperture near the journal and a spring catch in said aperture engaging into the recess in the sand band. 3rd. In a device for attaching metal wheels to axles, the combination with a metal wheel of the character described and complete in itself of a sand band provided with an inwardly projecting flange forming an interior recess in the sand band, interlocking means for attaching the sand band to the inner end of the wheel hub, and a spring catch on the axle comprising a leaf spring secured at one end to the axle and carrying at the other a catch working through an aperture in the axle. 4th. In a device for attaching metal wheels to axles, the combination with a wheel complete in itself of the sand band G provided with the inwardly projecting flange h and means for securing it to the inner end of the hub, the axle, the leaf spring I secured thereto and provided with projections for operating it with the fingers, the aperture l in the axle and the pin m secured to the free end of the leaf spring and guided in the aperture l of the axle.

**No. 57,337. Negative Electrode for Zinc Accumulators. (Electrode négatif pour accumulateurs de zinc.)**

Leger Bomel and the firm of Bisson, Berges & Co., both of Paris, France, 4th September, 1897; 6 years. (Filed 21st July, 1897.)

*Claim.*—A negative electrode for accumulators constituted by the combination of a supporting conducting strip and a trough or basin containing mercury in which the said strip rests, this arrangement allowing, whilst charging, of continuous amalgamation, by the

mercury which creeps along the strip, of the electrolysed zinc which is deposited upon it and whilst discharging, of the recuperation and

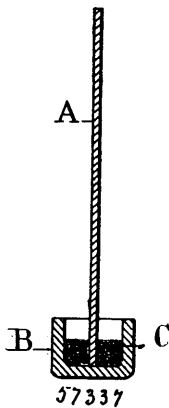

preservation of the mercury which may thus be used again and again indefinitely.

**No. 57,338. Self-Locking Hat Pin.**  
(*Epingles à chapeau*)

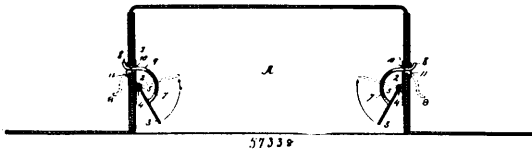

Joseph Stauber, Brookville, Kansas, and William Lonsdale Holloway, Kansas, Missouri, both in the U.S.A., 4th September, 1897; 6 years. (Filed 17th July, 1897.)

*Claim.*—1st. In combination with a hat, having a perforation, a hat-pin or fastener, comprising a base-plate, having a registering opening, a comb-like pin hinged to said base-plate, a curved arm secured to said pin and projecting through said registering openings, and a spring *q*, formed by bending the arm back upon itself, with its free end disposed adjacent to the hat, substantially as described. 2nd. The combination with a lady's hat, provided with an elongated opening, and an eyelet therein, of a hat-pin consisting of a base-plate secured to the inner side of the hat and provided with an opening registering with one end of the elongated eyelet, a comb-like pin hinged to said plate, an arm secured at one end to said pin, and extending through said openings and eyelet, and bent to form a foot-portion at its outer end to limit the downward movement of the pin, and a spring connected to said arm and extending through said eyelet and opening, and adapted, when the pin is elevated, to be withdrawn from the opening and bear against the outer side of said base-plate within said eyelet, substantially as described.

**No. 57,339. Rod Coupling.** (*Bielle d'accouplement.*)

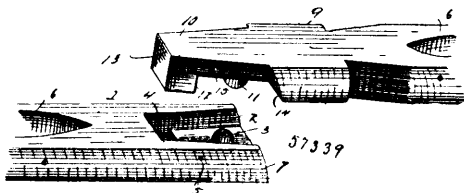

Theodore Charles Munz, Toledo, and Jacob Dillinger, Tiffin, both in Ohio, U.S.A., 4th September, 1897; 6 years. (Filed 23rd July, 1897.)

*Claim.*—In a coupling for rods, a section provided with a conical recess, an inclined end to the wall, a recess formed with a shoulder, and a section having a conical and projection with a depending portion to fit the recess and abut against the wall, and an inclined portion coincident with the inclination of the first section, and a transverse perforation extending through both sections, and coincident when assembled with a pin extending through the perforation.

**No. 57,340. Pump for Raising and Measuring Liquids.**  
(*Pompe à liquides.*)

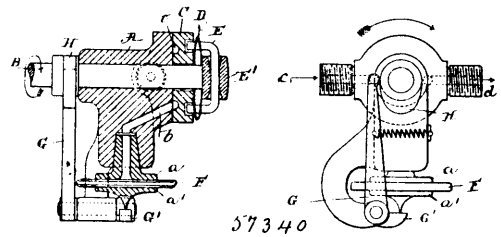

George T. Harris, Philadelphia, Pennsylvania, U.S.A., assignee of Emil Capitaine, Frankfort, Germany, 4th September, 1897; 6 years. (Filed 26th July, 1897.)

*Claim.*—1st. A pump for delivering measured quantities of fluid, comprising a valve, with means to actuate the same, said valve being provided with a grooved passageway, inlet and outlet passages with which said grooved passageway of the valve will register, a diaphragm, with means to actuate the same, a passageway in the body of the pump between the diaphragm and the grooved valve passage, and cam mechanism mounted on the driving mechanism, and arranged to alternately distend and contract said diaphragm in proper order of time relatively to the movement of the said valve; substantially as specified. 2nd. A pump for measuring and delivering small quantities of liquid, comprising the pump body *A* provided with passages *c, d*, a valve having a grooved passageway *o* adapted to register therewith, a shaft *B* adapted to actuate the valve, a diaphragm *F* and passageway *b* communicating therewith, and cam mechanism mounted on the driving shaft and arranged to actuate said diaphragm in proper order of time relatively to the movement of the valve; substantially as described. 3rd. A pump for measuring and delivering small quantities of liquid, comprising a pump body provided with inlet and outlet passages, a valve having a passageway therein adapted to be brought into register with the said inlet and outlet passages by proper movement, a diaphragm, a passageway leading from said diaphragm to the said valve and adapted to be brought into communication with the passageway thereof, and means for operating said valve and diaphragm in proper order of time relatively to each other, substantially as specified.

**No. 57,341. Temperature Regulating Apparatus for petroleum motor.**  
(*Régulateur de température pour moteurs à pétrole.*)

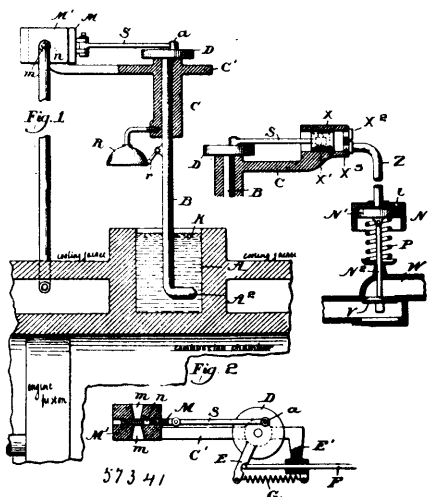

George T. Harris, Philadelphia, Pennsylvania, U.S.A., assignee of Emil Capitaine, Frankfort, Germany, 4th September, 1897; 6 years. (Filed 26th July, 1897.)

*Claim.*—1st. Mechanism operating automatically, at a predetermined temperature, to govern a cold water or cold air supply, in engines of the character described, consisting of the combination with fusible metal, a vessel to contain the same, arranged contiguous to or integral with the chamber to be cooled, a rod with one end inserted in the fusible metal, a disc mounted on the other end of said rod, a supporting frame for the disc and rod, water-controlling devices actuated by the partial rotation of the disc, spring mechanism to reciprocate the disc in one direction, and mechanism actuated

by the engine to reciprocate the disc in the opposite direction; substantially as described. 2nd. The combination with engines of the character described, and with devices adapted to supply a cooling current of water or air thereto, of mechanism operating automatically to actuate said water or air supplying devices, consisting of a chamber integral with or contiguous to the chamber to be cooled, a readily fusible metal therein, a rod immersed by one end in said metal, a disc mounted on the rod, connecting actuating devices between the disc and the water supply devices, and means to actuate the disc when such actuation is permitted by the melting of the fusible metal; substantially as described. 3rd. In an engine of the class described, the combination of a tank or receptacle contiguous to or integral with the wall of the chamber to be cooled and containing easily fusible material, means for supplying a cooling fluid to said wall, valve mechanism controlling said supply, and a device partially immersed in said fluid and operatively connected with said valve mechanism, said device being arranged to be operated by a moving part of the engine while said material is in a fused state, and to be rendered inactive by the hardening of said material; substantially as described. 4th. The combination in engines of the character described, of a chamber A, a fusible metal contained therein, a rod B, supporting frame C<sup>1</sup>, having sleeve C, a disc D mounted on the rod B and having an arm E, and a bracket E', on the frame, a spring G between the arm E and the bracket E', a rod F driven by the engine and adapted to contract with the arm E when it shall be released by the melting of the fusible metal, a cold water or air supplying device, and connecting actuating devices between the same and the disc D; substantially as described. 5th. The combination in engines of the character described, of a chamber integral with or contiguous to the chamber to be cooled, and containing readily fusible metal of actuating devices governed thereby, that is to say, will be actuated when such fusible metal is molten and will otherwise be normally quiescent, and water supplying mechanism controlled by such actuating devices, consisting of an air pump X, piston cylinder N, spring controlled piston N<sup>2</sup> and water valve V, W, the same being constructed, combined and operating, substantially as and for the purpose set forth.

**No. 57,342. Magnetic Ore Separator.**

(Separateur magnetique des mineraux.)

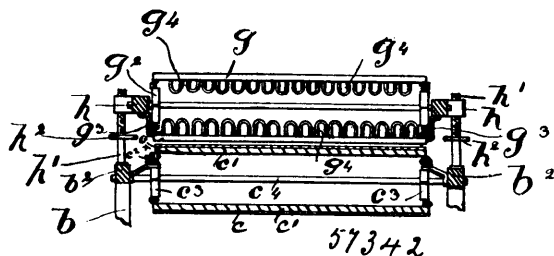

Francis Charles Crean, Joliette, George A. Cowan, Frank Westrope Lamplough and Joseph Rowat Fair, all of Montreal, and all in Quebec, Canada, 4th September, 1897; 6 years. (Filed 4th May, 1897.)

*Claim.*—1st. A separator for separating magnetic from non-magnetic material, comprising a series of travelling magnets, means for carrying said magnets, means for feeding the ore in minute particles thereto and means for adjusting the power of attractions of said magnets relatively to the material to be separated, for the purpose set forth. 2nd. A separator for separating magnetic from non-magnetic materials of ores when in minute particles, comprising a travelling carrier for the ore and a travelling carrier for a series of magnets, a series of magnets carried by said magnet carrier and said magnet carrier being disposed and arranged to travel parallel to said ore carrier and a short distance therefrom and from the ore carried thereby, for the purpose set forth. 3rd. A separator for separating magnetic from non-magnetic materials of ores when in minute particles, comprising a travelling carrier for the ore and a travelling carrier for a series of magnets, a series of magnets carried by said magnet carrier and said magnet carrier being disposed and arranged to travel parallel to said ore carrier and a short distance therefrom and from the ore carried thereby and means for adjusting said carriers to and from one another, for the purpose set forth. 4th. A separator for separating magnetic from non-magnetic materials of ores when in minute particles, comprising a travelling carrier for the ore and a travelling carrier for a series of magnets, a series of magnets carried by said magnet carrier and said magnet carrier being disposed and arranged to travel parallel to said ore carrier and a short distance therefrom and from the ore carried thereby, said travelling carrier being adapted and operated to travel in the same direction and the magnet carrier at a greater speed than the ore carrier, thus causing more than one magnet to pass over any given point upon the carrier. 5th. In a separator for separating magnetic from non-magnetic materials of ores when in minute particles, the combination of a frame, a travelling ore carrier, a distributor located above one end of said carrier, said distributor consisting of a box having a bottom formed of gauze or netting, said distributor extending the full width of the carrier, means for agitat-

ing said distributor, an inclined sieve located above said distributor and having its bottom of a mesh corresponding to the mesh of the gauze forming the bottom of the distributor, an adjustable travelling magnet carrier consisting of a travelling belt formed of a series of slats or cross-pieces secured at their ends to endless chains, means for supporting said chains against sagging at their lower level of rotation, said magnet carrier being adapted to travel in a parallel line to and a short distance from the surface of the ore carrier and the ore carried thereby, means for adjusting said magnet carrier to and from said ore carrier, the magnet being disposed in varying lines over the surface of said slats or cross-pieces, a pair of high speed rotary brushes adapted to rotate in contact with the magnets, and means for operating said carriers and brushes for the purpose set forth. 6th. A separator for separating the magnets from the non-magnetic materials of ores, comprising a series of travelling magnets disposed in lines at right angles and acute and obtuse angles of varying degrees, means for carrying said magnets, and means for feeding the ore in minute particles thereto, for the purpose set forth. 7th. In a separator for separating magnetic from non-magnetic materials of ores when in minute particles, the combination of a frame, an ore carrier consisting of a pair of endless belts one enclosed within and operating the other, the inner belt being formed of a series of slats secured at their ends to endless chains adapted to take around a pair of sprocket-wheels, the outer belt consisting of a loop of canvas or the like, adapted to take around a pair of drums located adjacent to and outside of said sprocket-wheels, and rest upon said slats the whole being supported at their upper level of rotation by means of a pair of rails, an adjustable travelling magnet carrier consisting of a travelling belt formed of a series of slats or cross-pieces secured at their ends to endless chains, means for supporting said chains against sagging at their lower level of rotation, side magnet carrier being adapted to travel in a parallel line to and a short distance from the surface of the ore carrier and the ore carried thereby, said magnetic carrier being supported in a frame having screw-threaded bearings formed thereon, a series of rotatable screw-threaded standards resting at their lower ends upon said first mentioned frame and taking through said screw-threaded bearings at their upper ends, said standards being provided with hand wheels, a pair of high speed rotary brushes adapted to rotate in contact with the magnets, and means for operating said carriers and brushes, substantially as described and for the purpose set forth.

**No. 57,343. Signal Bell.** (Sonerie electrique.)

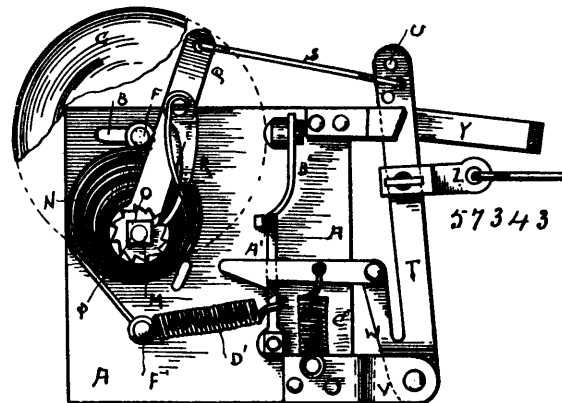

Engelbrecht Olsen, Walkerville, Montana, U.S.A., 4th September, 1897; 6 years. (Filed 20th July, 1897.)

*Claim.*—1st. In a signal bell, a post for the support of the bell, and which is adjustable back and forth with relation to the hammer, combined with suitable means for operating the hammer, substantially as shown. 2nd. In a signal bell, a slotted supporting plate, a post for the support of the bell, and which is adjustable back and forth in the slot, and the bell which is removable secured to the post, combined with means for operating the hammer of the bell, substantially as described. 3rd. In a signal bell, a supporting-plate provided with a slot B, and an opening C, at one end of the slot, the post F, having the reduced portion J to fit in the slot B, and a sleeve applied to the post, combined with the bell G, nut I, and a means for operating the hammer, substantially as set forth. 4th. In a signal bell, the supporting-plate provided with the slot B, C, the post F, that is adjustable therein, and the bell which is clamped upon the post, combined with the spring-actuated lever Q, carrying the spring-pawl R, the ratchet O, spring N, connecting-rod S, levers T, X, hammer B<sup>1</sup>, and the spring C<sup>1</sup>, D<sup>1</sup>, all combined and arranged to operate substantially as specified.

**No. 57,344. Bark Cutter.** (Coupe écorce.)

Samuel Wesley Butterfield, Three Rivers, Quebec, Canada, 4th September, 1897; 6 years. (Filed 3rd August, 1897.)

*Claim.*—1st. In a bark cutter, the combination, with a revoluble disc provided with knives on its face, and a casing provided with

an opening at its upper part, of a carriage secured to the front end of the said casing and provided with an inclined support, a bracket

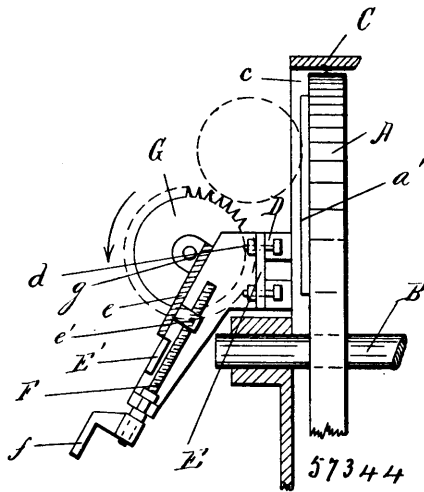

slidable on the said support, toothed wheels journalled in the said bracket and arranged to support the log in front of the cutters, and driving mechanism for revolving the said wheels, substantially as set forth. 2nd. In a bark cutter, the combination, with a revoluble cutting disc, and its casing provided with horizontal guides, of a carriage slidable on the said guides and provided with an inclined support, a bracket slidable on the said support, and toothed wheels, for supporting and revolving the log in front of the said disc, journalled in the said bracket, substantially as set forth. 3rd. In a bark cutter, the combination, with a shaft and toothed wheels for supporting the log, of a slidable bracket carrying the said shaft and wheels, a carriage supporting the said bracket, a driving pulley carried by the said carriage, a shaft and intergearing bevelled toothed wheels driven from the said pulley, and an intermediate shaft and universal joints coupling the adjacent ends of the two aforesaid shafts, substantially as set forth.

**No. 57,345. Upright Piano-forte Action. (Piano.)**

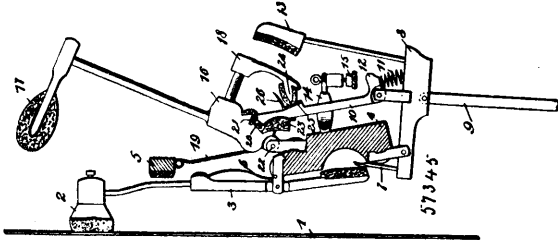

Francis Louis Becker, New York, State of New York, U.S.A., 4th September, 1897; 6 years. (Filed 30th July, 1897.)

*Claim.*—1st. In an upright piano-forte action, the combination with a hammer butt pivoted on the action-frame, a hammer carried thereby, a jack, means for operating said jack from the key lever, and escapement mechanism for said jack, of a shoulder located on said hammer butt at a distance from the pivotal point of the jack greater than the distance between the hammer butt pivotal point and said pivotal point of the jack with which said jack contacts to impart its stroke to said hammer butt and hammer, substantially as set forth. 2nd. In an upright piano-forte action, the combination of a hammer butt pivoted on the action-frame, a hammer carried thereby, a jack, means for operating said jack from the key lever, a jack spring for normally pressing said jack against the hammer butt, escapement mechanism for said jack, and a shoulder located on said hammer butt at a distance from the pivotal point of the jack greater than the distance between the hammer butt pivotal point and said pivotal point of the jack with which said jack is adapted to contact, the latter operating to impart the stroke to said hammer through said shoulder and to remain out of contact therewith while the key is depressed, but, when said key is partially released, to move the hammer forward again towards the string through the medium of the jack spring alone pressing said jack against the hammer butt, thus permitting the end of said jack to re-engage with the shoulder on the hammer butt in position for a repetition stroke, substantially as set forth. 3rd. In an upright piano-forte action, the combination with a hammer butt pivoted on the action frame, a hammer carried thereby, a counter check also carried thereby, a back check, a jack adapted to normally engage with said hammer butt, means for operating said back check and jack from the key lever, and

escapement mechanism for said jack, of a projection carried by said counter check and adapted to contact with said jack as the key is released to force said jack beneath the hammer butt shoulder by the weight of the hammer and hammer butt alone, substantially as set forth. 4th. In an upright piano-forte action, the combination with a hammer butt pivoted on the action-frame, a hammer carried thereby, a jack, means for operating said jack from the key lever, a jack spring for normally pressing said jack against the hammer butt, and escapement mechanism for said jack, of a shoulder located on said hammer butt with which said jack is adapted to contact to impart its stroke to said hammer butt and hammer, and a cushion attached to said hammer butt beneath said shoulder and depending below the bottom of said hammer butt against which the jack is adapted to contact when impelled by its spring beneath the shoulder on the hammer butt and which thereby operates to check the movement of the hammer towards the string, substantially as set forth. 5th. In an upright piano-forte action, the combination with a hammer butt pivoted on the action-frame, a hammer carried thereby, a counter check also carried thereby, a back check, a jack adapted to normally engage with said hammer butt, means for operating said back check and jack from the key lever, and escapement mechanism for said jack, of a projection carried by said counter check and adapted to contact with said jack to limit the movement of the hammer in its rebound from the string after its stroke, and a tongue carried by said jack and adapted to engage with said projection to clamp the counter check against the back check as the hammer rebounds from the string and to return said hammer to its initial position through said counter check as the jack descends upon the release of the key lever, substantially as set forth. 6th. In an upright piano-forte action, the combination with a hammer butt pivoted on the action-frame, a hammer carried thereby, a counter check also carried thereby, a back check, a jack adapted to normally engage with the hammer butt, means for operating said back check and jack from the key lever, escapement mechanism for said jack, a projection carried by said counter check and adapted to contact with said jack when the action is in its initial position and when the key lever is depressed, and a tongue carried by said jack and adapted to contact with said projection when the counter check is against the back check and as the jack descends to its initial position, the whole operating to impart the stroke to the hammer, to clamp said hammer against movement in either direction while the key is completely depressed, and to return the various parts to their initial positions when the key is released, substantially as set forth. 7th. In an upright piano-forte action, the combination of a hammer butt pivoted on the action-frame, a hammer carried thereby, a counter check also carried thereby, a back check, a jack adapted to normally engage with the hammer butt, means for operating said back check and jack from the key lever, a spring for normally pressing said jack against the hammer butt, escapement mechanism for said jack, a shoulder located on said hammer butt with which said jack is adapted to contact to impart its stroke to said hammer butt and hammer, a projection carried by said counter check and adapted to contact with said jack when the action is in its initial position and when the key lever is depressed, and a tongue carried by said jack and adapted to contact with said projection when the counter check is against the back check and as the jack descends to its initial position, the whole operating to impart the stroke to the hammer, to clamp said hammer against movement in either direction while the key is completely depressed, and to return the various parts to their initial positions when the key is released, substantially as set forth. 8th. In an upright piano-forte action, the combination of a hammer butt pivoted on the action-frame, a hammer carried thereby, a counter check also carried thereby, a back check, a jack adapted to normally engage with the hammer butt, means for operating said back check and jack from the key lever, a spring for normally pressing said jack against the hammer butt, escapement mechanism for said jack, a shoulder located on said hammer butt with which said jack is adapted to contact to impart its stroke to said hammer butt and hammer, a projection carried by said counter check and adapted to contact with said jack when the action is in its initial position and when the key lever is depressed, and a tongue carried by said jack and adapted to contact with said projection when the counter check is against the back check and as the jack descends to its initial position, the whole operating to impart the stroke to the hammer, to clamp said hammer against movement in either direction while the key is completely depressed, and to return the various parts to their initial positions when the key is released, substantially as set forth.

**No. 57,346. Tuning Pin for Pianos.**  
(Chevillette pour accorder le pianos.)

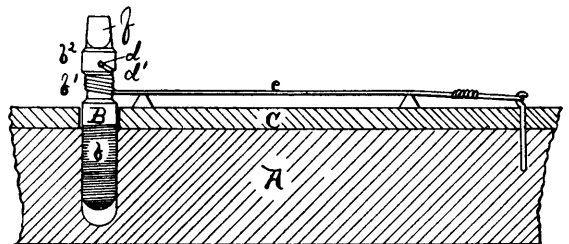

Levi Walker, Chatham, Ontario, Canada, 4th September, 1897; 6 years. (Filed 31st July, 1897.)

*Claim.*—A tuning pin for pianos having an enlarged straight milled body or lower part, a reduced shank or string winding part, an enlarged collar containing the hole for the engagement of the



and having the head or upper portion made to fit the ordinary tuning instrument, substantially as specified and hereinbefore set forth.

**No. 57,347. Machine for Graining Lumber.**  
(Machine pour greneler le bois.)

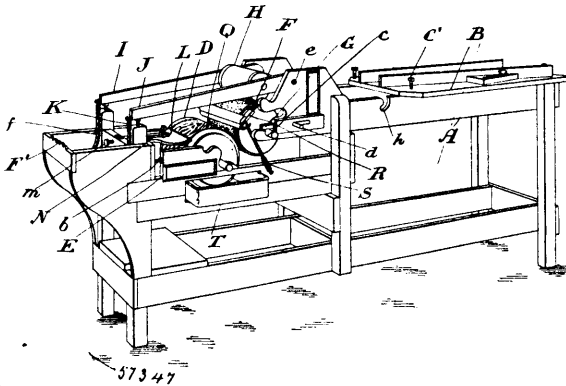

Hugh Silver, Lindsay, Ontario, Canada, 4th September, 1897; 6 years. (Filed 25th February, 1897.)

*Claim.*—1st. In a machine for graining lumber, a design roller having its surface formed of a thin sheet of bass wood bent round the roller with its grain running in the direction of the bend, a continuous grain pattern being indented in the surface of the wood, a paint fount within which the said roller revolves, and a scraper adapted to remove surplus paint from the surface of the roller, in combination with a composition printing roller adapted to revolve in contact with the said design roller, a pressure roller adapted to press the lumber against the said printing roller, and a scraper adapted to remove the pattern from the surface of the printing roller at a point after it has operated on the lumber and before a fresh impression is received from the design roller, substantially as and for the purpose specified. 2nd. In a machine for graining lumber, a design roller bearing a grain pattern, a paint fount within which the said roller revolves, and a scraper adapted to remove surplus paint from the surface of the roller, in combination with a composition printing roller adapted to revolve in contact with the said design roller, a U-shaped scraper adapted to remove the pattern from the surface of the printing roller at a point after it has operated on the lumber and before a fresh impression is received from the design roller, a pressure roller journaled on arms, each pivoted at one end to the frame of the machine and resting at the other upon an adjustable support, and springs adapted to hold down the said arms, substantially as and for the purpose specified. 3rd. In a machine for graining lumber, a design roller bearing a grain pattern and carried in bearings longitudinally adjustable on the frame, a paint fount within which the said roller revolves, and a scraper adapted to remove surplus paint from the surface of the roller, in combination with a composition printing roller adapted to revolve in contact with the said design roller, a U-shaped scraper adapted to remove the pattern from the surface of the printing roller at a point after it has operated on the lumber and before a fresh impression is received from the design roller, a pressure roller journaled on arms, each pivoted at one end to the frame of the machine and resting at the other upon an adjustable support, and springs adapted to hold down the said arms, substantially as and for the purpose specified. 4th. In a machine for graining lumber, a design roller bearing a grain pattern in intaglio, in combination with a flexible supported scraper having its edge curved in a vertical plane and a strip of flexible material connected thereto, substantially as and for the purpose specified. 5th. A frame for a machine of the class described, provided with a table B, adjustable bearings E, for a design roller, bearings a, for a printing, painting or sizing roller, bearings b, for a guide roller, bearings c, for a rotary brush, and the cross-bar o, adapted to carry a brush, substantially as and for the purpose specified. 6th. A frame for a machine of the class described, provided with a table B, adjustable bearings E, for a design roller, bearings a, for a printing, painting or sizing roller, bearings b, for a guide roller, bearings c, for a rotary brush, and the cross-bar o, adapted to carry a brush, and the notched cross-bar F', substantially as and for the purpose specified. 7th. A frame for a machine of the class described, provided with a table B, adjustable bearings E, for a design roller, bearings a, for a printing, painting or sizing roller, bearings b, for a guide roller, bearings c, for a rotary brush, and the cross-bar o, adapted to carry a brush, and the notched cross-bar F', substantially as and for the purpose specified. 8th. A frame for a machine of the class described, provided with a table B, adjustable bearings E, for a design roller, bearings a, for a printing, painting or sizing roller, bearings b, for a guide roller, bearings c, for a rotary brush, and the cross-bar o, adapted to carry a brush, and the notched cross-bar F', substantially as and for the purpose specified. 9th. A frame for a machine of the class described, provided with a table B, adjustable bearings E, for a design roller, bearings a, for a printing, painting or sizing roller, bearings b, for a guide roller, bearings c, for a rotary brush, and the cross-bar o, adapted to carry a brush, and the notched cross-bar F', substantially as and for the purpose specified. 10th. A frame for a machine of the class described, provided with a table B, adjustable bearings E, for a design roller, bearings a, for a printing, painting or sizing roller, bearings b, for a guide roller, bearings c, for a rotary brush, and the cross-bar o, adapted to carry a brush, and the notched cross-bar F', substantially as and for the purpose specified.

**No. 57,348. Automatic Stop for a Stave Joiner.**  
(Arrêt automatique pour joindre les douelles.)

Horace Brown Murdock, Detroit, Michigan, U.S.A., Henry C. Rees, South Woodlee, Ont., Canada, and Sherman D. Hooper, Detroit, Michigan, U.S.A., 4th September, 1897; 6 years. (Filed 21st July, 1897.)

*Claim.*—1st. In a stop for a stave joiner, a reciprocatory blade provided with means to limit the movement of the stave under the knife

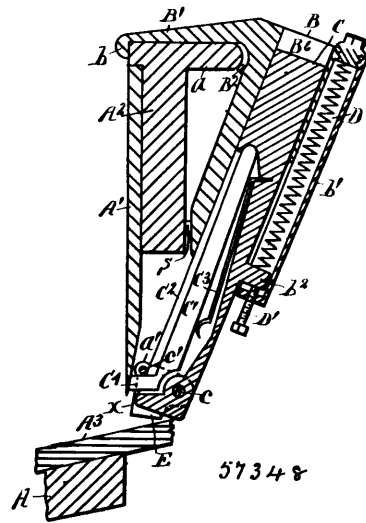

of the joiner, for the purpose set forth. 2nd. In a stop for a stave joiner, a reciprocatory blade provided with means to limit the movement of a stave under the knife of a joiner, said blade arranged to move upward and away from the knife of the joiner as the knife descends, for the purpose set forth. 3rd. An adjustable stop for a stave joiner attachable to the bar carrying the knife of the joiner, for the purpose set forth. 4th. A stop for a stave joiner, movable with the knife of the joiner, and upward and away from the knife when the knife descends, for the purpose set forth. 5th. In a stop for a stave joiner, a case provided with a chamber diverging upward and away from the plane of the knife, and a reciprocatory blade located in said chamber, provided with means to limit the movement of a stave under the knife of a joiner, for the purpose set forth. 6th. In a stop for a stave joiner, a reciprocatory blade provided with swinging jaws to limit the movement of a stave under the knife of a joiner, for the purpose set forth. 7th. In a stop for a stave joiner, an automatically retracting reciprocatory blade movable with the knife of the joiner, and also movable upward and away from the plane of the knife when the knife descends, said blade provided with means to limit the movement of a stave under the knife of a joiner, for the purpose set forth. 8th. A stop for a stave joiner, a reciprocatory blade movable away from the plane of the knife, a yielding arm provided with a shoulder at its lower end projecting toward the knife of the joiner and carried by said blade, said blade provided with swinging jaws adjacent to said, for the purpose set forth. 9th. In a stop for a stave joiner, a reciprocatory blade movable away from the plane of the knife, a yielding arm carried by said blade and provided with a shoulder at lower end projecting toward the knife, and a swinging jaw pivoted to the blade toward its lower end of the swing up adjacent to the rear edge of the knife, for the purpose set forth. 10th. In a stop for a stave joiner, a reciprocatory blade movable with the knife of the joiner and upward and away therefrom, a yielding arm carried by said blade provided with a shoulder at its lower end, a swinging jaw carried by said blade, and means to limit the movement of the jaws, for the purpose set forth.

**No. 57,349. Stringed Musical Instrument.**  
(Clavier pour instruments à corde.)

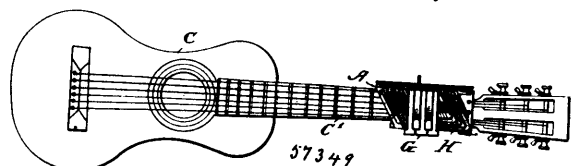

Justus Leonard Kelman, Kenney, Illinois, U.S.A., 4th September, 1897; 6 years. (Filed 11th August, 1897.)

*Claim.*—1st. The combination of the frame, the chord-producing bars, and actuating devices adapted to engage said bars, said actuating devices being hinged or pivoted to the frame and capable of being swung on their pivots until their lower surface is uppermost or substantially so, for the purpose of fully exposing the chord-producing bars, as set forth. 2nd. A device of the class described, provided with sets of pressers arranged to extend diagonally over



the fingerboard, and adapted to engage and press sets of strings, to produce chords when the corresponding strings are played, substantially as shown and described. 3rd. A device of the class described, comprising a suitable frame having open guideways, individual pressers each adapted to engage a single string, bars engaging a series of pressers to produce a chord, said bars being movable in said open guideways in the same direction as the pressers, that is, toward and from the strings, whereby they may be readily removed and exchanged, and means for actuating said bars, substantially as described. 4th. A device of the class described, comprising chord-producing bars, U-shaped levers engaging said bars, and keys engaging the said levers, substantially as described. 5th. A device of the class described, comprising chord-producing bars, actuating devices extending transversely of the bars, and operating blocks mounted on said actuating devices and adapted to engage said bars, said blocks being adjustable transversely of the bars to engage with any of them, substantially as described. 6th. A device of the class described, provided with sets of pressers each adapted to press a set of strings into chord position, bars for actuating the said pressers, keys for actuating the said bars, and sets of levers engaging the said bars and actuated from the said keys, substantially as shown and described. 7th. A device of the class described, provided with sets of pressers adapted to press a set of strings into chord position, bars for actuating the said pressers, keys for actuating the said bars, and sets of levers engaging the said bars and actuated from the said keys, each key being provided with an adjustable block for engagement with a bar, substantially as shown and described. 8th. A device of the class described, provided with sets of pressers each adapted to press a set of strings into chord position, bars for actuating the said pressers, keys for actuating the said bars, and sets of levers engaging the said bars and actuated from the said keys, each lever being provided with adjustable blocks for engagement with the corresponding bar, substantially as shown and described. 9th. A device of the class described, comprising a casing arranged for removable connection with the fingerboard of a musical instrument, a series of keys on the said casing, and each having blocks, a series of spring-pressed bars fitted to slide in the casing and adapted to be engaged by some of the blocks, a series of pressers engaged by the said bars, and adapted to press the strings, and a set of levers having blocks and controlled by the keys, the said set of levers being adapted to actuate the said bars, substantially as shown and described. 10th. The combination of the keys, the chord-producing bars operated thereby and arranged transversely thereof, and the diagonally arranged pressers operated by the said bars, substantially as described. 11th. The combination of the chord-producing bars and the actuating mechanism movable longitudinally of said bars, whereby the said mechanism may actuate different bars according to its position, substantially as described. 12th. The combination of the chord-producing bars, the levers slidable longitudinally of the bars and engaging the same, and the hinged keys engaging the levers, substantially as described. 13th. The combination of the chord-producing bars, the levers slidable longitudinally of the bars and engaging the same and the hinged keys engaging the levers, and likewise arranged to slide longitudinally of the bars, substantially as described. 14th. The combination of the frame having a diagonally arranged series of vertical guideways, chord-producing bars in said guideways, and mechanism for actuating said bars, substantially as described. 15th. The combination of the frame having a diagonally arranged series of vertical guideways, chord-producing bars in said guideways, U-shaped levers with diagonally arranged members engaging said bars, and means for actuating the levers, substantially as described. 16th. The combination of the chord-producing bars, the levers engaging the same, and having upward projections, and the hinged keys movable longitudinally of the bars and adapted to engage the said projections, substantially as described. 17th. The combination of the frame, having guideways, the chord-producing bars in said guideways, the springs for preventing the bars from dropping out, and mechanism for operating the said bars, substantially as described.

**No. 57,350. Alarm for Prison Cells, Vaults, Cages, etc.** (*Alarme pour cellules de prison, voûte, etc.*)

Frank Peterhansl, Brooklyn, New York, and George H. Rothmann, Rutherford, New Jersey, both in the U.S.A., 8th September, 1897; 6 years. (Filed 4th August, 1897.)

*Claim.*—1st. A prison cell, vault, cage, etc., provided with a network of connected pipes forming the wall, grating, door, or the like, a pipe leading from the said pipes and adapted to be connected with an exhaust device, said pipe having an outlet adapted to be closed by a spring actuated cover, and alarm operated by said cover, substantially as described. 2nd. A prison cell, vault, cage, etc., provided with a network or connected pipes forming the wall, grating, door, or the like, a pipe leading from the pipes and adapted to be connected with an exhaust device, said pipe having an outlet adapted to be closed by a spring-actuated cover, an alarm operated by said cover, and an indicator in the said pipe, substantially as described. 3rd. A window grating made of a series of connected pipes, a pipe with the said grating and leading to a central office, means for exhausting the air from the said pipe and grating, and an alarm valve held on the said pipe and closed by atmospheric pressure, and adapted to be opened by a spring, and an alarm adapted to be sounded on the opening of the said valve, as set forth. 4th. A window grating, made of a series of connected pipes, a pipe connected

with the said grating and leading to a central office, means for exhausting the air from the said pipe and grating, an alarm valve

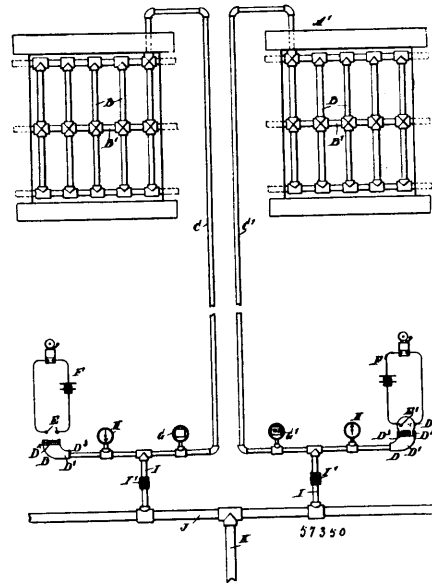

held on the said pipe and closed by atmospheric pressure, and adapted to be operated by a spring, an alarm adapted to be sounded on the opening of the said valve, and an indicator in the said pipe, substantially as shown and described. 5th. A door formed of a series of connected pipes, a pipe connected with the said pipes and having an extension, and a pipe leading from the said extension to a central office, the said pipe being provided with an alarm valve adapted to be opened by spring pressure on breaking one of the pipes, substantially as shown and described. 6th. A door formed of a series of connected pipes, one of which serves as a pindle, and provided with a hollow hasp connected with sundry of the pipes, and a pipe connected with the pipe forming the pindle and adapted to be connected with an air exhaust device, said pipe having an outlet adapted to be closed by a cover normally held open by a spring, substantially as described.

**No. 57,351. Body Supporting Syringe.** (*Seringue.*)

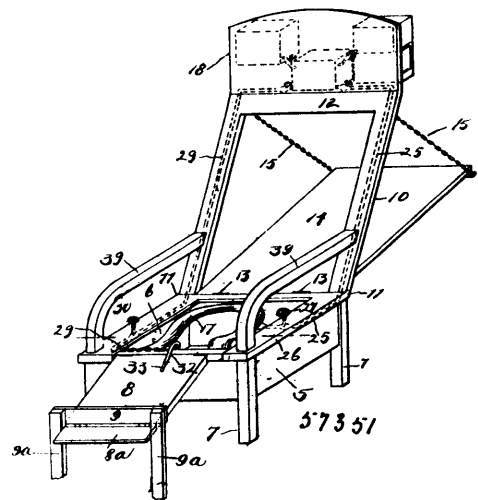

Joseph Billette White, East Orange, New Jersey, U.S.A., 8th September, 1897; 6 years. (Filed 28th July, 1897.)

*Claim.*—1st. A chair, seat or support for invalids, comprising a base, provided with an opening in the top thereof, and a hinged cover which is adapted to serve as a foot rest, said chair being also provided with a back which comprises a frame, and a central portion which is hinged to the base and which is adapted to be lowered, a hollow circular or curved cushion supported in said base, a water tank connected with the frame of the back, and water pipes con-

nected with said tank, one of said pipes being in communication with said cushion, and the other being provided with a flexible tube, substantially as shown and described. 2nd. A chair, seat or support for invalids, comprising a base, provided with an opening in the top thereof, and a hinged cover which is adapted to serve as a foot rest, said chair being also provided with a back which comprises a frame, and a central portion which is hinged to the base, and which is adapted to be lowered, a hollow circular or curved cushion supported in said base, a water tank connected with the frame of the back, and water pipes connected with said tank, one of said pipes being in communication with said cushion, and the other being provided with a flexible tube, and means for heating the water, substantially as shown and described. 3rd. A chair, seat or support for invalids, comprising a base, provided with an opening in the top thereof, and a hinged cover which is adapted to serve as a foot rest, said chair being also provided with a back which comprises a frame, and a central portion which is hinged to the base, and which is adapted to be lowered, a hollow circular or curved cushion supported in said base, a water tank connected with the frame of the back, and water pipes connected with said tank, one of said pipes being in communication with said cushion, and the other being provided with a flexible tube, and means for heating the water, substantially as shown and described. 4th. A chair, seat or support for invalids comprising a base, provided with a top plate in which is formed an opening, a cover for said opening, which is hinged to the front of the base, and which is adapted to serve as a foot rest, a back comprising a frame secured to the base, and a central portion which is hinged thereto, said central portion being adapted to be lowered, and said frame being provided at the top thereof with water tanks, which are in communication, and said base being provided with a circular hollow cushion which is supported therein, and two pipes which are in communication with one of said water tanks, one of said pipes being in communication with said hollow cushion, and the other being provided with a flexible tube, with which is connected a nozzle, substantially as shown and described. 5th. A chair, seat or support for invalids, comprising a base, provided with a top plate in which is formed an opening, a cover for said opening, which is hinged to the front of the base, and which is adapted to serve as a foot rest, a back comprising a frame secured to the base, and a central portion which is hinged thereto, said central portion being adapted to be lowered, and said frame being provided at the top thereof with water tanks, which are in communication, and said base being provided with a circular hollow cushion which is supported therein, and two pipes which are in communication with one of said water tanks, one of said pipes being in communication with said hollow cushion and the other being provided with a flexible tube with which is connected a nozzle, and said base being also provided with a removable drawer or receptacle, and means connected with one of the water tanks for heating the water therein, substantially as shown and described. 6th. A chair, seat or support for invalids, comprising a base, which is provided with a central opening and means for closing the same, said seat or chair being also provided with a support for the back, a hollow circular or curved cushion supported in said base below the opening formed therein, and a water tank connected with the back support, and pipes connected with said tank, one of said pipes being in communication with said cushion, and the other being provided with a flexible tube, and said back support being also provided with means for heating the water, substantially as shown and described.

**No. 57,352. Cash Register. (Registre de monnaie.)**

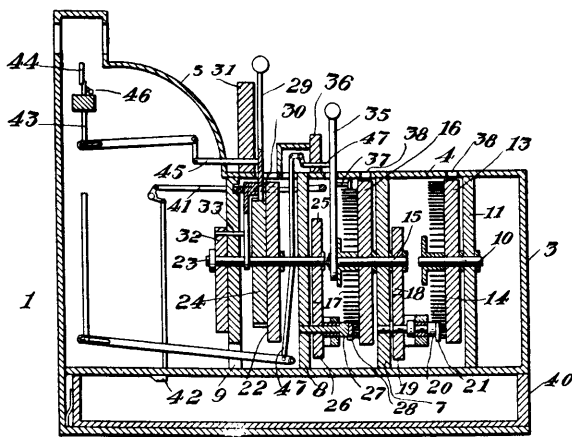

57352

John Eilers, Pana, Illinois, U.S.A., 8th September, 1897; 6 years. (Filed 30th July, 1897.)

*Claim.*—1st. A cash register comprising a series of digit-wheels geared to each other so that the rotation of one will turn the other

in succession, one or more of the digit-wheels having projecting teeth or ratchet-wheel, a lever having a pall engaging the pins or ratchet-teeth, and an indicator plate corresponding with the numerals on the wheel which the lever operates, substantially as shown and described. 2nd. In a cash register, the combination with the enclosing case, of a series of digit-wheels mounted thereon, one or more of the digit-wheels having projecting pins or ratchet-wheels, a lever pivoted within the machine and carrying a pall engaging the pins or ratchet-wheel, said lever extending through the enclosing case, and an indicator plate over which the lever travels, together with a series of wires projecting through the indicator plate, vertical rods carrying indicator cards, and a pivoted bar holding the rods elevated, substantially as shown and described. 3rd. In a cash register, the combination with a series of digit-wheels geared to each other so that the rotation of one will move the others in succession, pins or ratchet-wheels secured to one of the digit-wheels, a pivoted lever having a pall in engagement with the pins or ratchet-wheel, a rod forked at its upper end to engage both levers, and a catch to which forked rod is connected the said catch engaging the cash drawer, substantially as shown and described. 4th. In a cash register, the combination of a digit-wheel having a series of projecting pins, a second digit-wheel actuated upon a shaft having a gear-wheel thereon, a gear-wheel in mesh with the aforesaid gear-wheel and mounted on a shaft the end of which projects within the first-mentioned digit-wheel, and a finger on the end of the shaft engaging the pins of said digit-wheel, together with means for operating the second digit-wheel, substantially as shown and described. 5th. In a cash register, the combination of a digit-wheel having projecting pins, a second digit-wheel having pins, a gear-wheel mounted upon the shaft of the second digit-wheel and in mesh with the gear-wheel upon its supplemental shaft, a finger secured to the end of the shaft and engaging the pins of the first digit-wheel, a third digit-wheel having a ratchet-wheel, a large gear-wheel mounted on the shaft of the third digit-wheel, a pinion engaging the large gear-wheel and a finger projecting from the shaft of the pinion to engage the pins of the second digit-wheel, together with operating levers extending from the enclosing case, and having palls which engage the second and third digit-wheels, and an indicator plate over which the levers travel, substantially as shown and for the purpose set forth. 6th. In a cash register, the combination of a series of digit-wheels geared to each other so that the operation of one or more will turn the others in succession, a lever or levers to turn the digit-wheel and a segment having a pin which projects in the path of one or both operating levers, substantially as shown and for the purpose set forth.

**No. 57,353. Glass-blowing Machine.**

(Machine à souffler le verre.)

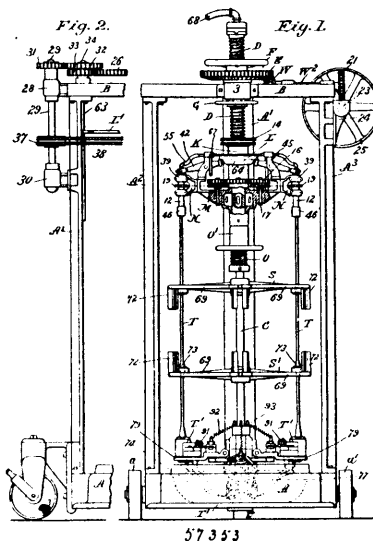

Henry Joseph Colburn, Toledo, Ohio, U.S.A., 8th September, 1897; 6 years. (Filed 31st July, 1897.)

*Claim.*—1st. In an automatic glass-blowing machine, a suitable base, and upright frame thereon, a vertically adjustable main-shaft suspended from a part of said frame over said base, and means for rotating said shaft, a series of moulds, blow-irons for said moulds supported in operative relation thereto, a main-head vertically adjustable on said shaft, said head, with said moulds and blow-irons rotating with said shaft, means on said main-head for positively engaging the upper extremities of said blow-irons, means for effecting a change in the speed of rotation of said blow-irons, relative to the speed of rotation of the main-shaft, means for supplying air at

varying pressures to said blow-irons, and means for automatically opening and closing said moulds, substantially as described. 2nd. In an automatic glass-blowing machine, a base and upright frame thereon, a vertically adjustable main-shaft suspended from a part of said frame over said base, and means for rotating said shaft, a main-head secured to said shaft and adjustable vertically thereon, a series of moulds secured to said shaft, and blow-irons for said moulds, one end of said blow-irons engaging the end of vertically moving hollow spindles rotatably supported on said main-head, levers pivotally supported on said main-head for moving said spindles, a suitable air-supply for said blow-irons, valves on said main-head for controlling said air-supply, and means for operating said valves and for moving said pivotally supported levers consisting of non-rotating cam surfaces supported on said main-head and engaging said valves and levers and movable vertically with said head, substantially as described. 3rd. In an automatic glass-blowing machine, a base and upright frame thereon, a main-shaft suspended from said frame over said base, and means for rotating said shaft, a main-head secured to said shaft and adjustable vertically thereon, a series of sectional moulds, blow-irons for said moulds, hollow spindles on said head for positively engaging one end of said blow-irons, and means of support on said shaft for said blow-irons, air-conduits between said hollow spindles and an air-reservoir in said head, valves in said air-conduits and pivotally supported levers engaging said hollow spindles, which valves and levers are operated by their engagement with stationary cam surfaces on said head, around which they are moved by the rotation of said head, combined with means for supplying air to said reservoir, substantially as described. 4th. In an automatic glass-blowing machine, a base and upright frame thereon, a main-shaft suspended from said frame over said base, and means for rotating said shaft, a main-head secured in said shaft and adjustable vertically thereon, a series of sectional moulds, blow-irons for said moulds, hollow spindles on said head for positively engaging one end of said blow-irons, and means of support on said shaft for said blow-irons, air-conduits between said hollow spindles, and an air-reservoir in said head, valves in said air-conduits and pivotally supported levers engaging said hollow spindles by one extremity and by their opposite extremities with stationary cam-surfaces on said head, around which said levers are moved by the rotation of said head, combined with means for supplying air to said reservoir, and means for rotating said blow-irons at different rates of speed independent of the speed of rotation of said main-shaft, substantially as described. 5th. In an automatic glass-blowing machine, a suitably supported main-shaft and means for rotating said shaft, a main-head secured thereon, a series of moulds secured to said shaft, blow-irons between said moulds and said main-head, air-conduits for conveying air to said blow-irons under varying pressures, means for opening and closing said moulds, and means for supporting and for rotating said blow-irons at varying rates of speed independent of said main-shaft, consisting of a spindle for engaging one end of said blow-irons, a member on said main-shaft rotating freely thereon, gear and band connections between said member and said spindle for rotating the latter, an auxiliary shaft on the frame of the machine parallel with said cam-shaft, a band connection between said auxiliary shaft and said member on the main-shaft, and interchangeable gear connections between the main-shaft and auxiliary shaft, whereby the latter may be rotated at varying rates of speed relative to the speed of said main-shaft, substantially as described. 6th. In an automatic glass-blowing machine, a suitably supported main-shaft vertically adjustable in its bearings and means for rotating said shaft, a main-head vertically adjustable on said main shaft and rotating therewith, suitable moulds carried around by said main-shaft in a circular path, suitably supported blow-irons, hollow spindles on said main-head engaging with one end of said blow-irons, driving connections on said head for said spindles, a blow-iron driving member on said main-shaft rotatable independently thereof, and means for rotating said member at varying speeds, an air-reservoir in said main-head, air-conduits therefrom to said hollow spindles, valves in said conduits for varying the supply of air passing to said spindles, means for moving said spindles vertically, and suitable air passages in said main-shaft communicating with said air-reservoir for supplying air thereto, substantially as described. 7th. In a glass-blowing machine, a sectional mould therefor, and means for operating the same consisting of a mould-carrier, mould-sections pivotally secured thereon, a block having a longitudinal movement on said carrier and one or more longitudinally yielding connecting arms engaging with said block and the sections of said mould, and means for moving said block whereby said sections are swung from and toward each other, substantially as set forth. 8th. In a glass-blowing machine, means for rotating the blow-irons thereof consisting of a rotatable hollow spindle 12, a mouth-piece 46, thereon having an opening in its lower end for the end of a blow-iron, a vertically movable cup 47, in said mouth-piece, a spring 47\*, between the top of said cup and the lower end of said hollow spindle, an angularly-shaped opening in said cup for receiving a similarly shaped end of a blow-iron, an air-valve in said spindle operated by said blow-iron to admit air to the latter, and means for rotating said hollow spindle, substantially as described. 9th. In an automatic glass-blowing machine, means for effecting the alignment of a blow-iron with its mould consisting of a blow-iron support 69, movable sockets in the ends of said arms for engaging said blow-iron, and means for adjusting said sockets in a plane at right angles to the axis of said blow-iron, substantially as

described. 10th. In a glass-blowing machine, a main-shaft and means for rotating said shaft, a series of blow-irons and means on said shaft for supporting the same, combined with means for rotating said blow-irons, and for effecting a change in the speed of rotation thereof relative to the speed of rotation of said main-shaft, substantially as described.

**No. 57,354. Machine for Lasting Boots & Shoes.**

(Machine à enformer.)

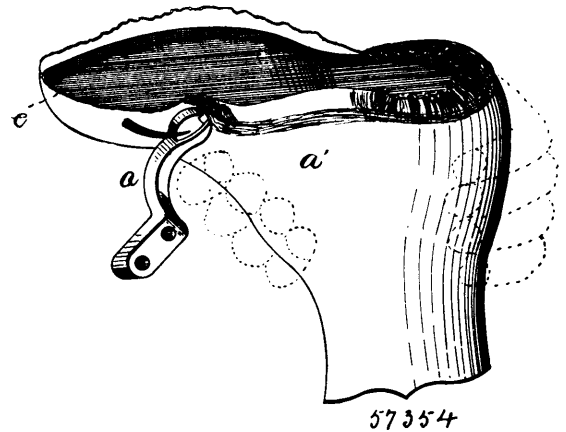

James Joseph Jordan and John Aaron Kelly, both of Syracuse, New York, U.S.A., 8th September, 1897; 6 years. (Filed 3rd August, 1897.)

*Claim.*—1st. The combination, with a stitch forming mechanism of a sewing machine, of an upper stretching device provided with a grooved portion which serves as a guide for the needle, and a series of teeth for catching in the edge of the upper and forcing it over the sole of the shoe, and means for reciprocating said device, substantially as shown. 2nd. A feeder provided at one end with means for securing it to the machine, and at the other a grooved portion or arm, which serves as a guide for the needle, and teeth which catch in the edge of the upper and force it over the sole, ready to be sewn, substantially as described.

**No. 57,355. Extension Mining Post.**

(Poteau de mine à rallonge.)

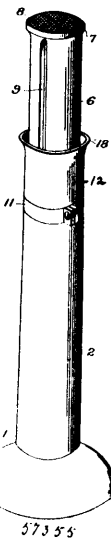

John Joseph Sullivan, Red Jacket, Michigan, U.S.A., 8th September, 1897; 6 years. (Filed 30th July, 1897.)

*Claim.*—In a mining post, the combination of a standard having a base with a series of radial lugs thereon and a central recess, a movable section mounted in the said standard and having grooves in the opposite side of the same, a sleeve on the said movable section, a collar surrounding the upper part of the standard, collar and sleeve having inwardly extending tongues to engage the opposite grooves of the said movable section, a screw extending upwardly through the base of the standard into the movable section, and a key having

an arm and adapted to be fitted over the head of the screw and lock the same against movement, substantially as and for the purposes specified.

**No. 57,356. Book and Manuscript Holder. (Porte-livre.)**

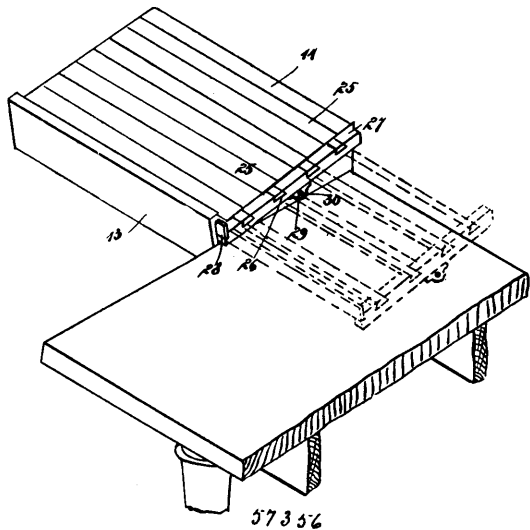

Elbert Duncan Hall, Mitchell, Iowa, U.S.A., 8th September, 1897 ; 6 years. (Filed 30th July, 1897.)

*Claim.*—1st. The combination of a bar having an upwardly bent portion at one end, a book rest having a passage receiving the upwardly bent portion of the bar, the book rest also having a recess in which the horizontal portion of the bar adjacent to the upwardly extending portion thereof projects, and two plates carried by the book rest and respectively located on the sides of the horizontal portion of the bar, whereby to limit the swinging movement of the bar relatively to the book rest, substantially as described. 2nd. A book rest having a frame plate with a recess in its lower portion and with a passage extending upwardly from the recess, a bar having a main portion and an upwardly bent portion, the main portion extending into the recess and the upwardly bent portion running into the passage, and two plates carried by the frame plate and adjustable toward and from the main portion of the bar, so as to regulate the movement of said bar relatively to the book rest, substantially as described. 3rd. The combination of a supporting bar, a book rest pivoted thereto, and two plates carried by the book rest and respectively on opposite sides of the supporting bar, the plates being movable toward and from the bar, so as to limit the movement of the bar relatively to the book rest, substantially as described. 4th. A book rest having a frame plate with a recess in its lower edge, the frame plate also having a passage extending upwardly from the recess, a supporting bar having an upwardly bent end, the supporting bar having a portion running into the recess and having the upwardly bent end revolvably mounted within the passage, a wear plate held against the upper wall of the recess and engaging the supporting bar, and two plates respectively carried by the frame plate and adjustable toward and from the supporting bar, the frame plates being located on opposite sides of the recess and serving to limit the movement of the bar relatively to the book rest, substantially as described. 5th. A book rest having a main portion, an extension slidably connected with the main portion, a supporting bar pivotally connected to the book rest, and a bar sliding in the main portion of the book rest and moved outward by the movement of the extension, the said bar being capable of engaging the supporting bar to assist in holding the book rest, substantially as described. 6th. The combination of a book rest, an extension sliding thereon, a bar moved outward by the extension and capable of engaging a support, and a supporting bar pivoted to the book rest, substantially as described. 7th. The combination of a book rest, an extension sliding thereon, and a bar sliding in the book rest and moved outward by the movement of the extension, the bar being capable of engaging a support to assist in holding the book rest, substantially as described. 8th. The combination of a book rest, an extension sliding on the book rest, a bar slidable in the book rest and connected rigidly to the extension, a second bar sliding in the book rest and capable of being moved by the movement of the first bar, and a supporting bar pivotally connected to the book rest, substantially as described. 9th. The combination of a book rest, an extension sliding thereon, a bar sliding in the book rest and rigidly connected to the extension, and a second bar also sliding in the book rest and moved by the movement of the first bar, substantially as described. 10th. The combination of a book rest, an extension sliding on the book rest, a bar also sliding on the book rest and rigidly connected to the extension, a lug on the bar, a second bar, sliding in the book rest, and two lugs on the second bar, the lugs on the second bar being respectively located on opposite sides of

the lug of the first bar, substantially as described. 11th. The combination of the table, the bar pivoted thereto adjacent to a corner thereof, and the book rest pivoted to the outer end of said bar and arranged to swing in the plane of the table so as to engage the latter at either of the sides meeting at said corner, substantially as described.

**No. 57,357. Colour Printing Machine.**

(Machine à imprimer les couleurs.)

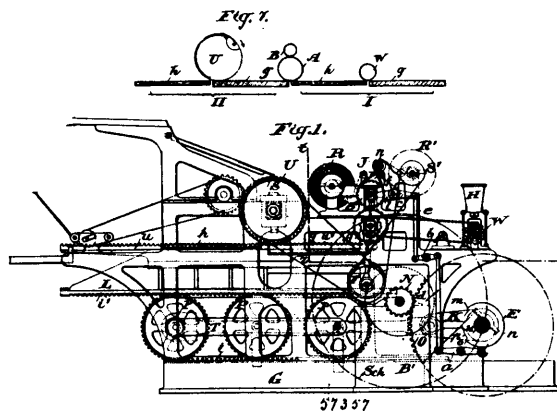

Vittorio Turati, Milan, Italy, 9th September, 1897 ; 6 years. (Filed 8th May, 1897.)

*Claim.*—1st. The combination, with an impression cylinder and a table or bed adapted to reciprocate relatively thereto, of a moistening cylinder mounted above the line of movement of the said table or bed, means for feeding a liquid to the said moistening cylinder, means for heating the latter to evaporate the said liquid, a transferring cylinder mounted intermediate the said moistening and impression cylinders, a wiping cylinder mounted above the said transferring cylinder, means for guiding a wiping strip between the said wiping and transferring cylinders, and means for intermittently moving the said wiping cylinder and wiping strip into and out of contact with the said transferring cylinder, substantially as and for the purpose described. 2nd. The combination, with an impression cylinder and a table or bed adapted to reciprocate relatively thereto, of a moistening cylinder mounted above the line of movement of the said table or bed, means for feeding a liquid to the said moistening cylinder, means for heating the latter to evaporate the said liquid, a transferring cylinder mounted intermediate the said moistening and impression cylinders, a wiping cylinder mounted above the said transferring cylinder, means for heating the said wiping cylinder, means for guiding a wiping strip between the said wiping and transferring cylinders and means for intermittently moving the said wiping cylinder and wiping strip into and out of contact with the said transferring cylinder, substantially as and for the purpose described. 3rd. The combination, with a table or bed adapted to reciprocate relatively to an impression cylinder and to support a surface of colours, a moistening cylinder, mounted above the line of movement of the said table or bed, means for feeding a liquid to the said moistening cylinder and means for heating the latter, to evaporate the said liquid in the intervening space between the said moistening cylinder and a surface of colours to be mounted on the said table or bed, substantially as and for the purpose described. 4th. The combination, with a reciprocating table or bed, adapted to support a surface of colours and a stone or other plate as described, of a device for moistening the colours without coming into contact with them mounted above the line of movement of the said table or bed, and a transferring cylinder mounted above the line of movement of the said table or bed so as to roll alternately over the surface of colours and the stone or other plate during the reciprocations of the said table or bed, provided with a wiping mechanism intermittently brought into contact with the said transferring cylinder, substantially as and for the purpose described. 5th. A moistening device consisting of the receptacle H, provided with adjustable discharge openings, and the rotatable hollow cylinder W journaled below the said receptacle, the said cylinder being provided with an absorbent outer surface to receive a liquid discharged from the discharge opening in the said receptacle and with means for heating the said cylinder and distributing the heat therein to evaporate the liquid, substantially as and for the purpose described. 6th. The transferring cylinder A and the heating and wiping cylinder B mounted above the same in such a manner as to admit of being moved into and out of contact with the said transferring cylinder, substantially as and for the purpose described. 7th. The combination, with a reciprocating table or bed, adapted to support a surface of colours and a stone or other plate as described, and with a moistening device mounted above the line of movement of the said table or bed, of a transferring cylinder mounted above the line of movement of the said table or bed so as to roll alternately over the surface of colours and the stone or other plate during the reciprocations of the said table or

bed, of a wiping mechanism intermittently brought in contact with the said transferring cylinder, and of means for heating the latter, substantially as and for the purpose described. 8th. The combination with a reciprocating table or bed, an impression cylinder, a moistening cylinder mounted at the end of the machine furthest removed from the impression cylinder, a transferring cylinder mounted intermediate the said moistening cylinder and impression cylinder, and a heating and wiping cylinder journaled immediately above the transferring cylinder in movable bearings, the impression, moistening and transferring cylinders being arranged immediately above the line of travel of the reciprocating table or bed, substantially as described and for the purpose specified. 9th. The combination or arrangement and use of mechanism whereby a film of colour is removed from a polychromatic, or mosaic block of composition by means of a transferring cylinder, is conveyed by such transferring cylinder to a stone, or other suitable plate or surface, and is taken therefrom on to the paper, or other material to be printed upon carried by a suitable impression cylinder or its equivalent, means for softening the surface of the mosaic block by means of vapour, without actual contact with the mechanism supplying such vapour and means for heating, cleaning and regulating, all substantially as and for the purpose set forth and illustrated.

**No. 57,358. Scoop. (Curette.)**

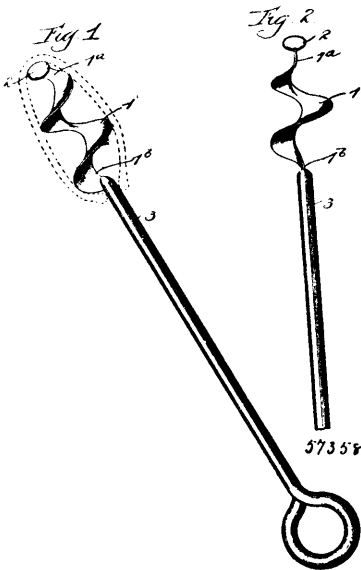

Emilien D. Saint Cyr, jr., Chicago, Illinois, U.S.A., 9th September, 1897; 6 years. (Filed 10th August, 1897.)

*Claim.*—1st. As a new and useful article of manufacture, a curette consisting of a flat spiral band forming an archimedean screw and having a button on one end and an operating stem on the other, substantially as set forth. 2nd. As a new and useful article of manufacture, a curette consisting of a flat spiral band forming an archimedean screw, and having a button on one end and an operating stem on the other, the said band being tapered towards said button, substantially as set forth. 3rd. As a new and useful article of manufacture, a curette consisting of an archimedean screw formed of a flat spiral band having its inserting end provided with a button and its other end provided with an operating stem, said band being widened towards the midlength of the screw, substantially as set forth. 4th. As a new and useful article of manufacture, a curette consisting of an archimedean screw formed of a flat spiral band having its inserting end provided with a button and its other end provided with an operating stem, said band being narrowed from a point intermediate of its ends towards both said stem and button and said screw being widened at substantially its midlength and tapering towards both ends and said stem and button being in line with the axis of the screw, substantially as and for the purpose set forth.

**No. 57,359. Musical Instrument.**

(Instrument de musique.)

Jay E. Walker, Lincoln, Kansas, U.S.A., 9th September, 1897; 6 years. (Filed 9th August, 1897.)

*Claim.*—1st. The combination with the finger board of a stringed instrument, the said board being provided with grooves, of a bar serving as a nut, having openings through which the strings pass, and slides located in the said grooves and connected with the said bar, and tension devices carried by the said

through which the strings pass, slides located in the said grooves and connected with the said bar, and tension devices carried by the said

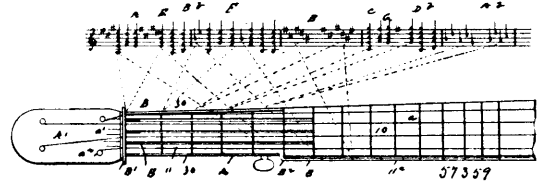

slides, whereby the slides will be held in the grooves when adjusted as and for the purpose specified. 3rd. A musical instrument having a stringed finger board, and a nut movable on the finger board and controlling the pitch of the string, the nut being formed with two connected sections having limited independent movement and holding the strings between their engaged faces, substantially as shown and described. 4th. A musical instrument having a stringed finger board with a transversely elongated nut sliding longitudinally on the finger board, the nut not being formed with two connected sections having limited, independent movement, and the said sections having the strings passed between and engaged by the contiguous faces of the sections, substantially as shown and described. 5th. A stringed instrument having a movable nut controlling the pitch of the string, the nut having two connected sections with limited independent movement and receiving the string between their engaged faces, substantially as described. 6th. A stringed instrument having a movable nut controlling the pitch of the string, the nut having two hinged sections receiving the string between their engaged faces, one of said sections having a latch pivoted thereto, and the second of the said sections having an eccentric slot in which a portion of the latch moves whereby to hold the sections in engagement with the string, substantially as described. 7th. A musical instrument, having a stringed finger board, a plurality of long strings on the finger board, a single short string on the finger board, means controlling the pitch of the long strings, and a nut for the short string the nut being slidable on the finger board and having two connected sections with limited independent movement, the sections receiving the short string between them, substantially as described. 8th. A musical instrument having a finger board with a plurality of long strings, a short string, and a nut for the short string, the nut being slidable on the finger board, and having two connected sections with limited independent movement, the sections receiving the short strings between them, substantially as described. 9th. A nut for controlling the pitch of musical instrument strings, the nut consisting in two sections movably connected with each other and having diagonally disposed contiguous faces, for receiving the string between them, substantially as described.

**No. 57,360. Tellurian. (Tellure.)**

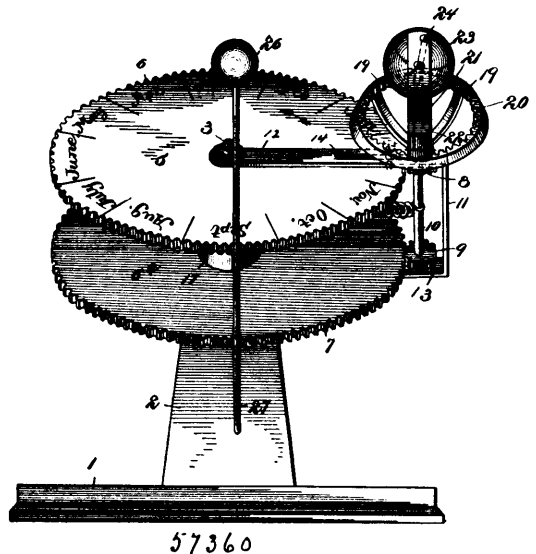

Josiah Lamborn Buxton, Silverton, Ohio, U.S.A., 9th September, 1897; 6 years. (Filed 6th August, 1897.)

*Claim.*—1st. In a tellurian, the combination of an inclined ecliptic-plate arranged in the plane of the ecliptic with relation to a contiguous sun globe, a swinging carrier-frame, a spindle mounted upon the carrier frame perpendicular to the plane of the ecliptic-plate, means for communicating rotary motion to the spindle during the movement thereof around and parallel with the periphery of the ecliptic-plate, a stirrup swivelled at an intermediate point upon the spindle and yieldingly held by gravity in its normal position, an

earth-globe having its spindle mounted in bearings in the upper ends of the arms of the stirrup at an inclination to the plane of the ecliptic-plate, and gearing for conveying rotary motion from the first-named spindle to the earth-globe, substantially as specified. 2nd. In a tellurian, the combination of an inclined ecliptic-plate of elliptical shape arranged in the plane of the ecliptic with relation to a contiguous sun-globe, and provided with indicating devices designating different seasons of the year, a swinging carrier-frame mounted for movement parallel with the plane of the ecliptic-plate, a spindle mounted upon the carrier frame and yieldingly held at a uniform distance from the periphery of the ecliptic-plate, said spindle being perpendicular to the plane of the ecliptic-plate, means for communicating rotary motion to said spindle during its movement around the ecliptic-plate, a stirrup mounted at an intermediate point upon said spindle and weighted at one end to hold it yieldingly in its normal position, an earth-globe mounted between the arms of the stirrup at the opposite end from the weight, and an internal gear carried by the spindle contiguous to the plane of the stirrup, the earth-globe being provided with a pinion meshing with the internal gear, whereby rotary motion is communicated from the spindle to the earth-globe, substantially as specified. 3rd. In a tellurian, the combination of parallel-spaced elliptical and auxiliary plates arranged parallel with the plane of the ecliptic and provided with peripheral gear-teeth, a sun-globe arranged contiguous to the ecliptic-plate, a swinging carrier-frame having slotted upper and lower arms arranged respectively contiguous to the planes of said plates, an operating shaft arranged concentrically with the plates and having one of the arms of the swinging frame attached thereto, a spindle mounted for radial movement in aligned slots in the arms of the carrier-frame, for movement toward and from the peripheries of the plates, and carrying pinions meshing with the gear-teeth thereon, a stirrup swivelled upon the said spindle, an earth-globe mounted between the arms of the stirrup with its axis at an inclination to the plane of the ecliptic-plate, an internal gear carried by said spindle, and meshing with a pinion on the earth-globe, and yielding means for maintaining the pinion on said spindle in engagement with the gear-teeth of the plates, said means consisting of a ring seated upon a spacing block between the plates, and a contractile spring connecting said ring with the spindle, substantially as specified.

**No. 57,361. Stop and Waste Valve. (Soupape.)**

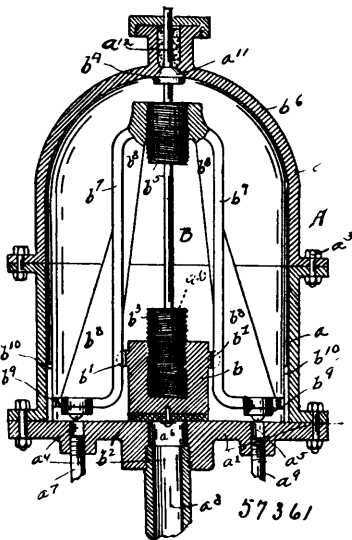

William B. Guimarin, Atlanta, Georgia, U.S.A., 9th September, 1897; 6 years. (Filed 2nd August, 1897.)

*Claim.*—1st. In a stop and waste cock, a casing having two inlets, an outlet passage and a drain passage, a stem rotatably mounted in said casing, right-hand and left-hand screw-threads on said stem, a valve mounted on and adapted to traverse one of said screw-threads, and governing the main inlet passages, and a hub carrying arms thereon mounted on the stem on the other of said screw-threads so as to traverse same, valves carried on the lower ends of said arms, and governing the other inlet and the drain-passage, and means for preventing the independent rotation of said arms and valve around said stem, for the purpose specified. 2nd. In a stop and waste cock, a casing having two inlets an outlet passage and a drain passage, a stem rotatably mounted in said casing, right-hand and left-hand screw-threaded plugs on said stem, a valve having lugs on its sides and mounted on, and adapted to traverse one of said plugs and governing the main inlet-passage and a hub carrying arms thereon mounted on the other of said plugs so as to traverse same, and

engaging the lugs on said valve, their free ends moving in guides on the casing, valves carried on the lower ends of said arms, and governing the other inlet and the drain-passage and said guides on said casing.

**No. 57,362. Fabric Printing Machine. (Machine à imprimer les tissus.)**

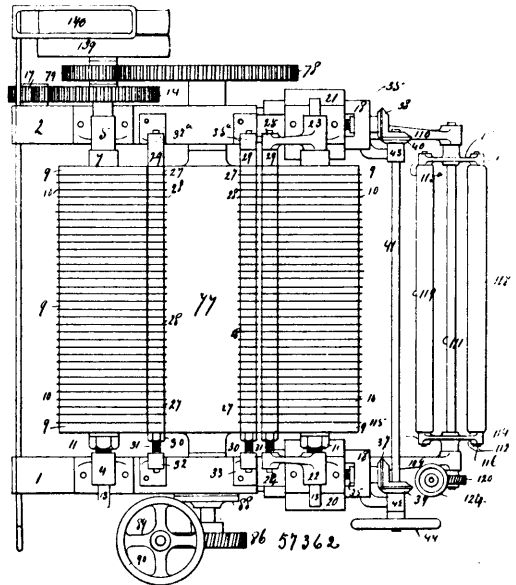

Samuel Holt Sharp, Grove Works, Claypit Lane, Leeds, York, England, 9th September, 1897; 6 years. (Filed 16th February, 1897.)

*Claim.*—1st. A printing machine wherein two or more endless metallic tapes or bands are passed, side by side, around main rollers by which they are kept taut, and partly below a fixed presser, and are maintained at the requisite distance apart by suitable guiding means so as to admit of the printing composition being forced by the fixed presser between the tapes or bands and into the fabric travelling with and pressed against the tapes or bands so as to produce on the said fabric the required stripe or stripes, the endless tapes or bands being suitably perforated when it is desired to also produce on the fabric, dotted lines or patterns, or designs other than and additional to the stripe or stripes. 2nd. In a fabric printing machine, the combination of endless travelling tapes arranged side by side and parallel with each other, guiding devices adapted to maintain said tapes at the requisite distance apart, an endless travelling blanket between which and the under lengths of said tapes the material to be printed passes, and a presser arranged to bear upon the upper surface of the under lengths of said tapes to force printing composition through the longitudinal spaces between the tapes and into the fabric, substantially as described. 3rd. In a fabric printing machine, the combination of endless travelling tapes arranged side by side and parallel with each other, means for maintaining them at a short distance apart, a presser arranged to force printing composition through the space between the tapes, and a presser on the opposite side of the tapes to receive the fabric and force it into the said spaces, substantially as described. 4th. In a fabric printing machine, the combination of a pair of main rollers one of which is mounted in fixed bearings, and the other in movable bearings, endless metallic tapes passing around said rollers, means for maintaining said tapes or bands at the requisite distance apart, a rotary cylinder pressed against the lower surface of the under lengths of the tapes, and a fixed presser arranged to bear against the upper surface of the under lengths of said tapes substantially as herein described for the purpose specified. 5th. In a fabric printing machine, the combination of main rollers formed with guide flanges, and one of which is movable toward and from the other, auxiliary guiding devices arranged in proximity to said rollers, endless tapes or bands passing around said rollers, and guiding devices and held apart thereby, an endless travelling blanket, a pressing cylinder arranged to force said blanket against the lower surface of the under lengths of said tapes, and a presser arranged above the said pressing cylinder and bearing upon the under lengths of said endless tapes, substantially as described and shown for the purpose specified.

**No. 57,363. Cash Register and Indicator, (Registre de monnaie.)**

Henry S. Hallwood, assignee of John H. McCormick, both of Columbus, Ohio, U.S.A., 9th September, 1897; 6 years. (Filed 24th July, 1897.)



*Claim.*—1st. In a cash register, a series of department registering devices each consisting of registering wheels of different denomina-

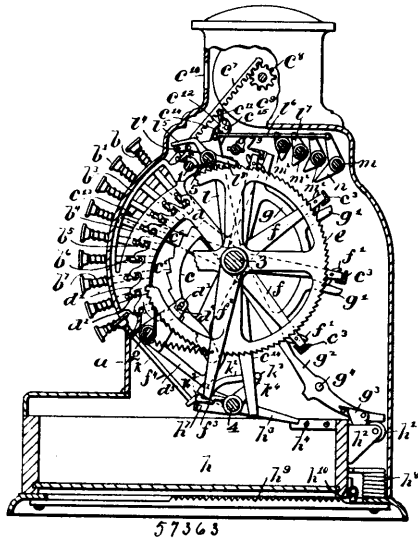

tions, actuating levers, one for each wheel, pivoted concentric with said wheels, actuating bars extending across the entire series of wheels so as to contact with said levers, a keyboard having denominational keys adapted to control the movement of said bars, locking means for holding the actuating levers of each department and special keys for operating said locking means, substantially as specified. 2nd. In a cash register, a series of registering wheels journaled in line with each other, said wheels being arranged in sets, an actuating device for each wheel of each set and means for normally locking said actuating devices, actuating bars extending across the entire set of wheels and pivoted concentric therewith, cash keys for releasing and determining the movement of said bars, a connection from said bars to the actuating devices of the respective wheels, and special keys for unlocking said actuating devices, substantially as specified. 3rd. In a cash register, cash keys and registering devices, said registering devices being grouped into departments, each compartment comprising wheels of different denominations, actuating devices comprising hinged or pivoted bars concentric with said wheels and common to all the groups for operating the registering-wheels, one bar for each denomination, a total adding register independent of the department registers but actuated by the common actuating devices, and means for releasing the department registering devices to cause one or more of them to operate in unison with the total adding register, substantially as specified. 4th. A cash register, cash keys arranged in series, each key of each series being adapted to release and determine the movement of a pivoted actuating bar, registering wheels of different denominations arranged concentric with said actuating bar having pawl levers to contact with and be moved by said bar, an intermediate supporting device for said actuating bar, and a movable cash receptacle, said supporting device being connected to and adapted to be operated by the opening and closing of said receptacle, substantially as specified. 5th. In a cash register, a series of keys arranged on the arc of a circle as described, a swinging segment pivoted eccentrically on a shaft adjacent to said keys, said keys being of different lengths and adapted to be moved in line with said segment, means for limiting the movement of said keys, and a series of steps on said segment to contact with the respective keys, substantially as specified. 6th. In a cash register, a series of keys arranged on the arc of a circle as described, said keys having stems of varying lengths adapted to be moved so as to stand in line with a swinging segment having a series of teeth or steps thereon, means connected with said segment for determining the movement of registering devices, and an engaging plate for holding the respective keys in their respective positions when one key is depressed, substantially as specified. 7th. In a cash register, a series of keys and a series of registering devices, each of said registering devices being adapted to register the amount indicated by said keys, means for normally holding the registering devices in an inoperative position, a normally-closed cash receptacle and a locking device for said cash receptacle adapted to be operated by the operation of a key, means for releasing the actuating devices of said registering mechanism and at the same time operating an additional locking device to said drawer whereby the drawer is held in a locked position until one of the registering devices is brought into position for operation, substantially as specified. 8th. A series of cash keys, and indicating devices connected thereto, an actuating device for each set of keys adapted to be released and controlled when one key

of said series is depressed, a series of registering devices arranged in groups and each adapted to be operated by the common actuating device, locking means for retaining said registering devices in a normally inactive position, a total adding register normally connected to said actuating device and independent of said normally inactive registers, and special keys for releasing said normally inactive registering devices to cause one or more of them to operate in unison with the total adding device by the operation of said actuating devices or any one of them, substantially as specified. 9th. Cash keys arranged in series, each series corresponding to a different denomination, each key of said series representing a unit of said denomination, an actuating device for each denomination adapted to be released when any key of its series is depressed, registering devices arranged in groups, each group comprising registering wheels representing denominations corresponding to the denominations of the actuating devices, locking means for retaining said registering devices in a normally inactive position, and a releasing device for each set of registering devices, a total adding registering device comprising registering wheels similar to the normally inactive registering devices, and normally connected to said actuating devices, and means, substantially as described, for releasing any group of registering devices to cause it to operate in unison with said total adding device, substantially as specified. 10th. A series of cash keys having straight stems of different lengths, a swinging segment pivoted eccentrically on a shaft adjacent to said keys, and an actuating bar connected to said segment, registering wheels journaled in line with the centre of said swinging segment, said registering wheels being arranged in groups or sets, and connecting devices between said actuating bar and one of said registering wheels, locking means for holding said registering devices in a normally inactive position, and special keys for operating said locking means to cause said registering wheels to be operated by the actuating bar when the cash key is depressed, substantially as specified. 11th. A curved key board, cash keys arranged in sets on said key board, each set representing a different denomination and each key representing a unit of that denomination, a swinging segment eccentrically pivoted on a shaft adjacent to said keys, said keys each having a stem of different length communicating with said segment, a series of registering wheels journaled in line with the centre of said segment, and an actuating bar on said segment extending across the faces of said wheels and moving concentrically therewith, and connections between said actuating bar and the registering wheels corresponding thereto whereby said wheels are moved by said actuating bar when one or more keys are depressed, substantially as specified. 12th. In a cash register, a series of keys having stems of different lengths, and an eccentrically-arranged segment having steps to contact with said key stems, an actuating bar connected to said segment, and registering wheels arranged in different sets connected to said bar, and an indicating wheel connected to said segment adapted to indicate the position of said actuating bar, substantially as specified. 13th. A series of cash keys and a series of registering wheels, an actuating bar extending across said wheels and controlled by said keys to determine the movement of said registering wheels, an intermediate support for said actuating device operated by the opening and closing of a cash receptacle, transferring mechanism to carry amounts from one registering wheel to those of a higher denomination, and means, as described, connected with said support to operate said transferring mechanism when said support is returned to its normal position, substantially as specified. 14th. In a cash register, a series of cash keys and a series of registering wheels, actuating bars extending across said wheels and controlled by said cash keys connected to said wheels, and registering wheels representing units of different denominations, and transferring mechanism for conveying amounts from one wheel to the wheel of the next higher denomination, a supporting device actuated by the opening and closing of a cash receptacle and adapted to normally support said actuating devices, and means connected with said support to operate said transferring mechanism as the cash receptacle is closed, substantially as specified. 15th. In a cash register, a normally-closed cash receptacle having two independent locking devices therefor, a series of keys each adapted to operate one of said unlocking devices and at the same time set in operation an indicator to indicate the amount represented by said key, a department key for releasing the registering devices of a certain group or set adapted to operate the unlocking device, and a connecting mechanism adapted to be moved by an independent operating key to simultaneously move both of said locking devices, and means as described for releasing said indicator to permit the same to return to zero when said locking devices are simultaneously operated, substantially as specified. 16th. In a cash register, a normally closed cash receptacle having two independent locking devices each adapted to be operated by a separate mechanism essential to the operation of the registering devices, and a separate independent drawer opening device adapted to simultaneously operate both of said locking devices without affecting the registering devices, substantially as specified. 17th. In a registering device, a series of keys and a series of actuating devices, an auxiliary support for said actuating devices normally detained by a movable cash receptacle, said support being held normally slightly removed from said actuating devices to permit an independent movement thereof when released by said keys, said support being adapted to return said actuating devices to their normal positions when the cash receptacle is closed, and means as described for permitting a limited back-



ward movement of said support after the actuating devices have been returned to their normal positions, substantially as specified. 18th. In a cash register, the combination with a series of registering keys and an independent actuating device, a series of indicating wheels each having a rack and pinion, the respective racks being adapted to be operated by the actuating devices, a pivoted bar journaled in spring-actuated hinged arms adapted to engage in the teeth of all of said racks, said bar being adapted to be moved into a plane parallel with said racks and thus release all of said racks when one of said racks is moved in a forward direction, and means as described for reversing the position of said bar causing it to retain the rack so elevated when the same reaches the limit of its forward movement, substantially as specified. 19th. A series of keys and a series of actuating devices connecting said keys and a series of indicating wheels for each set of keys, a rack and pinion connected to each of said indicating wheels adapted to be operated by one of said actuating devices, a pivoted bar journaled in spring-actuated arms and adapted to engage the teeth of all of said racks, said bar being moved into a plane parallel with the racks so as to disengage the teeth thereof whenever one rack is moved in a forward direction, means for reversing said bar to cause it to engage said racks when the cash receptacle is opened, and means as described for releasing all of said racks by the depression of an independent operating key, substantially as specified. 20th. In a cash register, a keyboard formed on the arc of a circle having a series of keys with stems of different lengths, and lateral projections on each of said key stems, a frame having bearings for said key stems, and a pivoted frame adjacent thereto, said frame being formed eccentric to the keyboard and provided on its periphery with hooks having bevelled ends, as described, said hooks being adapted to stand opposite the lateral projections so as to engage the same as the keys are depressed, and an eccentrically-arranged contacting device adjacent to said keys adapted when released to engage the depressed keys, substantially as specified. 21st. In a cash register, the combination with a series of cash keys having stems of different lengths and arranged on the arc of a circle, an eccentrically arranged web or flange adjacent to said keys, and a series of slotted openings in said flange, one for each key, laterally extending projections on said key stems projecting through said slotted openings and an eccentrically arranged pivoted frame adjacent to said flange having on its periphery hook-shaped projections with bevelled ends to engage said key projections, substantially as specified. 22nd. In a cash register, a normally locked cash receptacle and a normally-inactive registering mechanism, a series of keys adapted when depressed to determine the movement of said registering mechanism, a pivoted frame having hook-shaped projections adapted to engage laterally-extending projections on said key stems when said keys are depressed, a normally-locked intermediate actuating device adapted when released to connect with said key stems, a connection from said movable frame to the locking devices of said cash receptacle, and said intermediate actuating device, respectively, whereby the movement of said frame to lock the keys unlocks the cash receptacle and the intermediate actuating devices, substantially as specified. 23rd. In a cash register, a series of cash keys, a normally-locked cash receptacle, and a normally-inactive registering mechanism, an intermediate actuating device adapted when released to connect with said keys and determine the movement of said registering mechanism, a movable frame having bevelled projections to engage with said keys, and means connected with said movable frame for simultaneously unlocking said intermediate locking device and said cash receptacle, substantially as specified. 24th. The combination with a series of indicating wheels and a rack and pinion for each of said wheels, a pivoted bar common to all of said racks and adapted to engage with the teeth of the same, said bar being journaled at each end in swinging arms to permit it to lie parallel with or at an angle to said racks, a movable cash receptacle and means connected therewith for moving said swinging arms when the cash receptacle is opened to cause the pivoted bar to engage with each of said racks, substantially as specified. 25th. The combination with the indicating wheels and their operating racks, of a pivoted bar extending across said racks and common to all of the same, said bar being journaled in swinging arms as described, a normally inactive registering mechanism and a connection from said registering mechanism to each of said racks, and means substantially as described for operating the swinging arms to cause said pivoted bar to engage with each of said racks when the registering mechanism is set into operation, substantially as specified. 26th. The combination with a series of keys having stems of different lengths as described, and a swinging segment having a series of teeth or steps adapted to connect with said keys, register-operating mechanism connected to said segment, a locking plate arranged adjacent to said keys adapted to engage with the projections thereon, a bell crank lever connected to said locking plate, a normally-locked cash receptacle, and means, substantially as described, for unlocking said cash receptacle and said segment by the operation of said bell crank lever, substantially as specified. 27th. In a cash register, a normally-inactive registering mechanism comprising a series of wheels and concentric pivoted actuating bars extending across said wheels, cash keys for determining the movement of said bars when released, and an intermediate support for said bars actuated by the opening and closing of a cash receptacle, transferring mechanism adapted to be set by but actuated inde-

pendent of said registering mechanism, means connected with said bars for actuating the registering devices when the intermediate support is moved in one direction, and means connected with said support for operating the transferring mechanism when the intermediate support is moved in one direction, and means connected with said intermediate support for operating the transferring mechanism when said support is moved in the opposite direction, substantially as specified. 28th. In a registering mechanism comprising two wheels representing units of different denominations, one of said wheels having a series of projections arranged at intervals corresponding to the units of the next higher denomination, a lever pivoted concentric to said wheels and carrying a pawl, and a latch for said pawl, an arm connected to said latch and adapted to engage the projections on the wheel of a lower denomination, said pawl being normally held by said latch out of engagement with but in line with the teeth of the wheel of the higher denomination, means for producing a limited movement of said pivoted lever after each movement of said registering wheels, said pawl being adapted to engage the teeth of the wheel of the higher denomination if released by said latch but not otherwise, substantially as specified. 29th. In a cash register, a normally-closed cash receptacle, normally-locked registering devices and special keys for unlocking the same, cash keys for controlling the movement of said registering devices when unlocked, independent locking devices for the cash receptacle connected to said cash keys and said special keys, respectively, whereby the operation of a special key and a cash key is made essential to the opening of the cash receptacle in connection with the registration, and an independent drawer key adapted to simultaneously operate both of said locking devices without affecting the registering devices, substantially as specified. 30th. A cash register having a series of normally-inactive registering devices and cash keys for determining the movement of the same, special keys for releasing said registering devices, a normally closed cash receptacle having independent locking devices, one of said devices being connected to said cash keys and the other to said special keys whereby the opening of the cash receptacle by the single operation of either a cash key or a special key is prevented, substantially as specified.

#### No. 57,364. Pneumatic Plugger for Dental Work.

(*Tampon pneumatique pour dentistes.*)

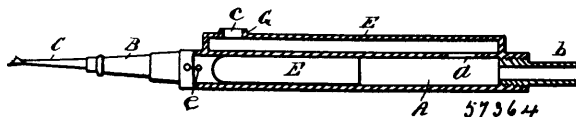

Abram Pelham, William O. Allen and Roswell Root, all of Plymouth, Michigan, U.S.A., 9th September, 1897; 6 years. (Filed 10th July, 1897.)

*Claim.*—1st. In a pneumatic plugger, the combination of the cylinder carrying at one end the plugging or filling tool, and connected at the other end with an air pump for creating an alternating current of air, the plunger in said cylinder, said cylinder having a vent opening at its lower end below the end of said plunger, and a larger vent opening at its upper end adapted to be closed by the hand of the operator. 2nd. In a pneumatic plugger, the combination of the cylinder, the tool attached thereto, said cylinder communicating with a pump for supplying an alternating air current and having a vent opening at the lower end thereof and a larger vent opening at the upper end thereof, the housing embracing said opening in the upper end of the cylinder, said housing being closed and having a vent opening only at its lower end, and the reciprocal plunger within said cylinder.

#### No. 57,365. Device for Moistening and Sealing Envelopes, etc. (*Appareil à humecter et sceller les enveloppes.*)

Asahel W. Eddy and Charles Robert Applegate, both of Coleridge, Nebraska, U.S.A., 9th September, 1897; 6 years. (Filed 3rd August, 1897.)

*Claim.*—1st. In an envelope moistening and sealing machine, a casing, a moistening roller adapted to receive the gummed flap of the envelope, feed rollers arranged below the moistening roller and in such relation thereto as to receive the body of the envelope while its flap is in engagement with the aforesaid moistening roller, sealing rollers between which the envelope in its moistened condition is to be passed, and a conducting device located between the guide rollers and the sealing rollers, as and for the purpose specified. 2nd. In an envelope moistening and sealing machine, a casing, a moistening roller adapted to receive the gummed flap of the envelope, feed rollers arranged below the moistening roller and in such relation thereto as to receive the body of the envelope while its flap is in engagement with the aforesaid moistening roller, sealing rollers between which the envelope in its moistened condition is to be passed, a conducting device located between the guide rollers and the sealing rollers, and a guide partition located upon the said conducting device at a point between the space intervening the guide rollers and the sealing rollers, as and for the purpose specified. 3rd. In a machine for moistening and sealing envelopes and like

packages, the combination with a casing, a moistening roller and a guide roller located above the moistening roller, the casing being

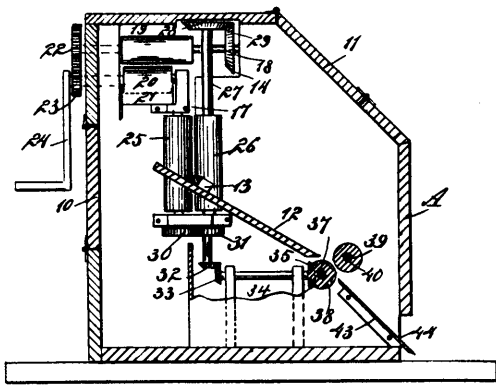

57365

provided with an opening adjacent to one end of the moistening roller and at an angle to the said roller, of feed rollers located at each side of the aforesaid slot, an inclined partition extending across the feed rollers, and sealing rollers located at the lower end of the aforesaid partition, as and for the purpose specified. 4th. In a machine for moistening and sealing envelopes and like packages, the combination with a casing provided with a moistening roller, and a guide roller substantially in contact with the moistening rollers, the two rollers being horizontally located and the casing being provided with a vertical slot adjacent to one end of the moistening roller, of perpendicular guide rollers located one at each side of the said perpendicular slot, an inclined partition crossing the feed rollers, sealing rollers located at the lower end of the said partition, and means, substantially as described, for driving one of the rollers, and a driving connection between all of the rollers upon operating one of them, as and for the purpose specified. 5th. In a machine for moistening and sealing envelopes, the combination with a casing, a moistening roller located in the said casing, a guide roller adapted to turn in conjunction with the moistening roller, the casing being provided with a slot at an angle to one end of the moistening roller, guides exteriorly located on the casing, one leading to the space between the moistening and guide rollers and the other to the said slot, of guide rollers located one at each side of said slot, an inclined partition crossing the said guide rollers and provided with a diagonal guide partition upon its upper face and adjacent to one of the guide rollers, sealing rollers located at the lower end of the said partition, and a driving mechanism operated on by the said rollers, as and for the purpose specified.

**No. 57,366. Gas Engine. (Machine à gaz.)**

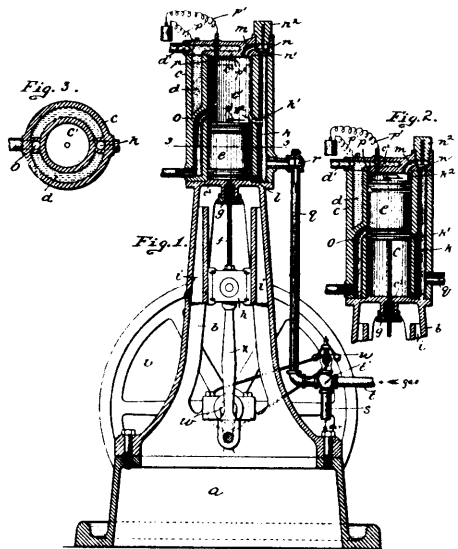

57366

Maxwell Wyeth & Company, assignee of John Dennison Russ, both of Brooklyn, New York, U.S.A., 9th September, 1897; 6 years. (Filed 26th July, 1897.)

Claim.—1st. In gas and like engines, the combination of a cylinder closed at both ends, a piston therein, said cylinder having a port

communicating with the space below the piston and above the lower head of said cylinder, a passage leading therefrom to the space above said piston when said piston is at its highest point, and a valve at the upper end of said passage, substantially as set forth. 2nd. In gas and like engines, the combination of a cylinder closed at both ends, a piston therein, said cylinder having an automatically valve-controlled port communicating with the space below the piston and above the lower head of said cylinder, a passage leading therefrom to the space above said piston when said piston is at its highest point, and a check valve at the upper end of said passage, substantially as set forth. 3rd. In gas and like engines, the combination of a cylinder closed at both ends, a piston therein, said cylinder having a port communicating with the space below the piston and above the lower head of said cylinder, a passage leading therefrom to the space above said piston when said piston is at its highest point, a check valve at the upper end of said passage, and an exhaust port opened and closed by said piston itself, substantially as set forth. 4th. In gas and like engines, the combination of a cylinder closed at both ends, a piston therein, said cylinder having a port communicating with the space below said piston and above the lower head of said cylinder, and a valve-controlled passage leading therefrom to the space above said piston when the piston is at its lowest "dead" point being larger than the cubic contents of lower portion of said cylinder when piston is at its highest "dead" point, substantially as set forth. 5th. In gas and like engines, the combination of a cylinder closed at both ends, a piston therein, said cylinder having a port communicating with the space below the piston and above the lower head of said cylinder, a passage leading from said port to the space above said piston when said piston is at its highest point, a valve controlling said passage, and an auxiliary port between said valve and said port leading from said passage to the piston chamber and controlled by said piston, substantially as set forth. 6th. In gas and like engines, the combination of a cylinder closed at both ends, a piston therein, said cylinder having a port communicating with the space below the piston and above the lower head of said cylinder, a passage leading from said port to the space above said piston when said piston is at its highest point, a valve controlling said passage, an auxiliary port between said valve and said first-mentioned port leading from said passage to the piston chamber, and an exhaust port just above said auxiliary port, both said exhaust port and auxiliary port being controlled by said piston, substantially as set forth.

**No. 57,367. Combination Tool. (Outil à combinaison.)**

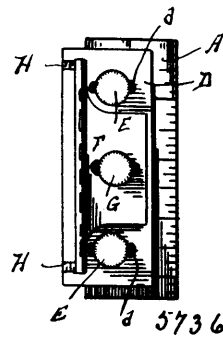

57367

Frank Elliott and John G. Shierling, jr., both of North Vernon, Indiana, U.S.A., 9th September, 1897; 6 years. (Filed 9th August, 1897.)

Claim.—1st. The combination of the base-plate having side lugs near each end thereof, extending in the same direction and projecting entirely beyond the side edge of said base-plate, with an L-shaped plate, guides upon said plates permitting a cross movement of one upon the other, the short arm of the L plate having openings therein to receive the lugs upon the base-plate, and means for clamping the two plates together. 2nd. The combination of the base-plate having side lugs near each end thereof, extending in the same direction, with an L-shaped plate, guides upon said plates permitting a cross movement of one upon the other, the short arm of the L-shaped plate having openings therein to receive the lugs of the base-plate, means for clamping the said plates together, and the third gauge-plate mounted upon the long arm of the L-shaped plate, and provided with means for adjusting it thereon.

**No. 57,368. Display Rack. (Râtelier-montre.)**

Willard J. Unkenholz, Livingston Manor, and John Unkenholz, Liberty, New York, both in the U.S.A., 9th September, 1897; 6 years. (Filed 28th July, 1897.)

Claim.—1st. In a display rack, the combination of upper and lower sprocket wheels, endless chains arranged thereon and provided at their inner edges with journals, receptacles having vertical sides, the resilient V-shaped hangers mounted on the outer faces of the sides of the receptacles, provided with bearing openings to receive

the journals and having their ends angularly bent and secured to the outer faces of the sides of the receptacles, said hangers being adapted

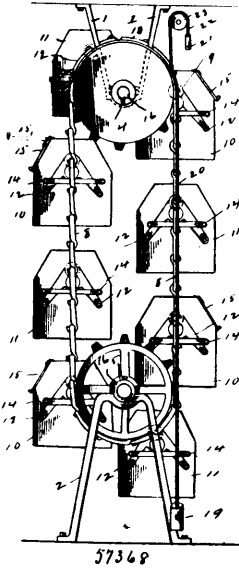

to be depressed to disengage them from the journals, and the transversely disposed guards extending horizontally across the hangers and having their ends angularly bent and secured to the outer faces of the receptacles, the transverse portion of the guards being interposed between the endless chains and the hangers and preventing the latter from springing outward too far, substantially as described. 2nd. In a display rack, the combination of upper and lower sprocket wheels, endless chains arranged thereon, receptacles located between the sprocket chains and connected therewith, a brake wheel connected with one of the sprocket wheels, a curved brake shoe arranged at the top of the brake wheel and hinged at one end, a weight connected with the other end and adapted to lift the shoe out of engagement with the brake wheel, and a heavier weight connected with the free end of the brake shoe for holding the latter in engagement with the brake wheel, substantially as described. 3rd. In a display rack, the combination of upper and lower bearing brackets, stub shafts journaled on the bearing brackets, sprocket wheels fixed to the stub shafts, endless chains arranged on the inner ends of the stub shafts, receptacles disposed at intervals and arranged between the sprocket chains and journaled thereon, a brake wheel connected with one of the stub shafts, a curved brake shoe arranged to engage the brake wheel and hinged at one end to a suitable support, a pulley located above the brake shoe, a cord passing over the pulley and having one end attached to the free end of a brake shoe, a weight connected to the other end of the cord and adapted to lift the brake shoe from the brake wheel, and a weight 19 connected with the free end of the brake shoe and adapted to hold the same in engagement with the brake wheel, substantially as described.

**No. 57,369. Sanitary Ejector. (Ejecteur sanitaire.)**

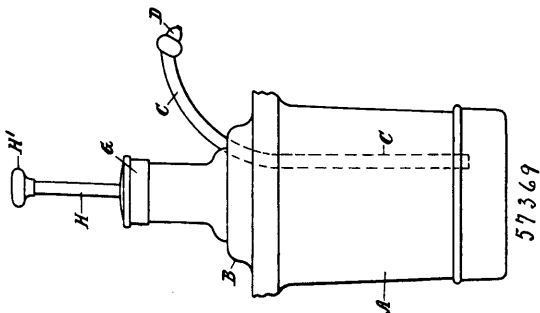

Louis O. Laurasons, London, Ontario, Canada, 10th September, 1897; 6 years. (Filed 25th January, 1897.)

*Claim.*—1st. A sanitary ejector, consisting of a reservoir A, cover B, piston chamber E, provided with the opening J, the spring F, contained within the piston chamber, the piston I, piston rod H and cap G, in combination with the tube C, substantially as and for the purpose set forth. 2nd. A sanitary ejector, consisting of a reservoir A, cover B, piston chamber E, provided with the opening J, the spring F, contained within the piston chamber, the piston I, piston rod H and cap G, in combination with the tube C, provided with the tip D, having a passage D<sup>1</sup> formed therein at an angle to the

passage in the tube C, substantially as and for the purpose set forth. 3rd. A sanitary ejector, consisting of a reservoir A, cover B, piston chamber E, provided with the opening J, the spring F, contained within the piston chamber, the piston I, piston rod H and cap G in combination with the syphon tube C, provided with the tip D, having the passage D<sup>1</sup> formed therein, said tube C being constructed as a syphon, so that as long as the pressure is retained on the knob H<sup>1</sup>, of the piston rod H, the soap will discharge through the passage D<sup>1</sup>, in the tip D, substantially as and for the purpose set forth.

**No. 57,370. Chalk or Crayon Holder or Protector.**

(Porte-crayon, etc.)

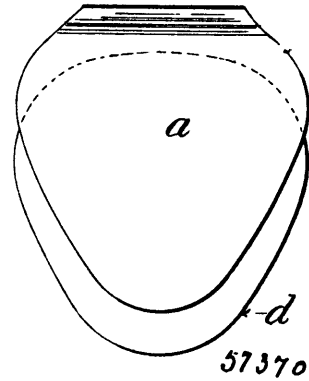

Joseph Bessell, Ludlow, Shropshire, England, 10th September, 1897; 6 years. (Filed 25th June, 1897.)

*Claim.*—In a chalk or crayon holder, two wings or flaps connected together and lined with india-rubber or such like material, and between which the chalk or crayon is held, substantially as shown and described.

**No. 57,371. Process for Making Printing Inks.**

(Procédé pour faire de l'encre à imprimer.)

David J. Ogilvy, Cincinnati, Ohio, U.S.A., 10th September, 1897; 6 years. (Filed 13th August, 1897.)

*Claim.*—1st. The process of producing printers' ink, which consists in placing in a suitable vessel black pigment together with suitable oil or oils and resinous material, in the proportions substantially as described, subjecting the mixture to the action of injected high pressure or superheated steam, and conducting off and condensing the more volatile products therefrom. 2nd. The process of making printing ink, which consists in placing in a suitable vessel a mixture of black pigment and suitable oil or oils, and injecting or introducing high pressure or superheated steam into the mixture, until the product is brought to the proper consistency, and to a fine state of division, condensing the more volatile products in the usual manner, the proportion of pigment depending upon the amount of distillate.

**No. 57,372. Stencil Sheet. (Feuilles à patroner.)**

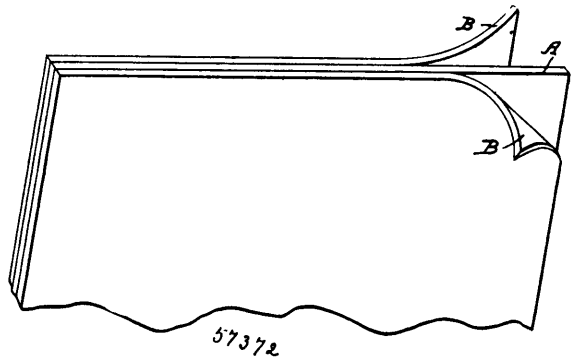

Thomas Headley Stackhouse, Philadelphia, Pennsylvania, U.S.A., 10th September, 1897; 6 years. (Filed 5th August, 1897.)

*Claim.*—1st. A compound stencil sheet, consisting of a sheet of thin, open fibrous paper, and a sheet or sheets of a close-grained, thin paper, said sheets being coated with a substance or substances impervious to ink, and being secured together, substantially as set forth. 2nd. A compound stencil sheet, consisting of a sheet of thin, open fibrous paper, and a sheet or sheets of a close-grained, thin paper applied to one or both sides of said first sheet, the whole coated with a substance impervious to ink, and being secured to-

gether, substantially as set forth. 3rd. A compound stencil sheet, consisting of a sheet of thin, open fibrous paper such as Japanese Yoshino paper, filled or coated with a substance impervious to ink, as paraffine, and a sheet or sheets of close-grained, thin paper placed upon one or both sides of said first sheet, and secured thereto by heat and pressure. 4th. A compound stencil sheet, consisting of a sheet of thin, open fibrous paper, as Japanese Yoshino paper, filled or coated with a substance impervious to ink, as paraffine, and a sheet or sheets of a close grained, thin paper coated or filled with a substance impervious to ink, as paraffine or oil, placed upon one or both sides of said first sheet, and secured thereto by pressure. 5th. A prepared compound sheet for use as a stencil sheet, consisting of two or more sheets, one of which is of an open, porous material, the other of close texture, one or more of said sheets being coated with a material impervious to ink. 6th. A prepared compound stencil sheet consisting of two or more sheets of paper at least one of which is of an open porous nature, and one or more of said sheets being coated or impregnated with a material impervious to ink. 7th. As a new article of manufacture, a prepared compound sheet for use as a stencil sheet, consisting of two or more sheets, one of which is of an open porous material, the other of a thin, close texture, one or more of said sheets being coated or impregnated with a material impervious to ink, substantially as set forth. 8th. As a new article of manufacture, a sheet for use as a stencil sheet, formed of two or more sheets, one or more of said sheets being of an open porous nature, and one or more of said sheets being coated or impregnated with a substance impervious to ink.

**No. 57,373. Riveting Machine. (Machine à river.)**

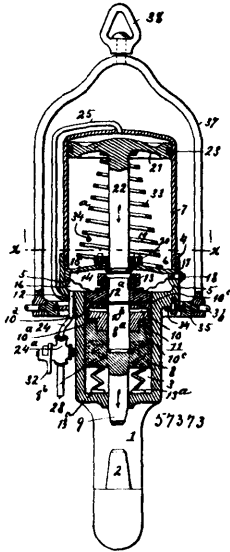

Alfred Parfitt, Topeka, Kansas, U.S.A., 10th September, 1897; 6 years. (Filed 2nd August, 1897.)

*Claim.*—1st. A riveting machine, comprising a frame having an arm or anvil, a piston provided with an arm to engage a rivet, a liquid chamber communicating with the piston chamber above said piston, a movable partition to displace a quantity of the liquid in said chamber, and thereby applying pressure upon the piston force it downwardly to engage the rivet, and a second piston or intensifier to operate upon said fluid and thereby increase the pressure upon the first-named piston and consequently upon the rivet engaged by the same, substantially as described. 2nd. A riveting machine, comprising a frame having an arm or anvil, a piston provided with the piston chamber above said piston, a movable partition to displace a quantity of the liquid in said chamber, and thereby applying pressure upon the piston force it downwardly to engage the rivet, a second piston or intensifier to operate upon said fluid and thereby increase the pressure upon the first-named piston and consequently upon the rivet engaged by the same, and means to return said pistons to their original positions after the pressure upon them is removed. 3rd. A riveting machine, comprising a suitable frame having an anvil or arm, and provided with a piston chamber, a piston therein provided with a stem to act in conjunction with said arm upon the rivet to be up-set, a liquid chamber in communication with the upper end of said piston chamber, a movable partition therein, a pressure supply pipe communicating with the liquid chamber at the side of the movable partition containing no liquid, a second piston or pressure intensifier, a pipe connecting the same with the supply-pipe, and a valve, which when operated permits the pressure agent to act upon and operate the movable partition and consequently operate the first-named piston, and then to cause such pressure agent to act upon the last-named piston and cause it

to intensify the pressure of said first-named piston upon said rivet, substantially as described. 4th. A riveting machine, comprising a suitable frame having an anvil or arm, and provided with a piston-chamber, a piston therein provided with a stem to act in conjunction with said arm upon the rivet to be up-set, a liquid chamber in communication with the upper end of said piston chamber, a movable partition there, a pressure supply pipe communicating with the liquid chamber at the side of the movable partition containing no liquid, a second piston or pressure intensifier, a pipe connecting the same with said supply pipe, a valve which, when operated, permits the pressure agent to first act upon and operate the movable partition and consequently operate the first-named piston, and then to cause such pressure agent to act upon the last-named piston and cause it to intensify the pressure of said first-named piston upon said rivet, a discharge pipe which may be put in communication by said valve with the pipes leading to said chambers after the riveting operation is completed, and means to return such pistons to their original positions, simultaneously with the escape of the pressure agent through the discharge pipe, substantially as described

**No. 57,374. Mason's Jointer. (Fiche à jointoyer.)**

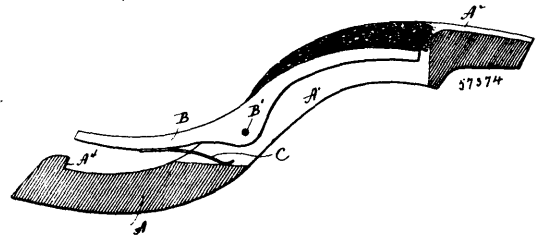

Dennis O'Brien, Middleton, Connecticut, U.S.A., 10th September, 1897; 6 years. (Filed 9th August, 1897.)

*Claim.*—1st. In a mason's jointer, the combination with a frame or body containing a mortar-receiving cavity, of a pivotally mounted lever having a pointing end located in the cavity, and an operating end adapted to be engaged by the hand for manipulation of the lever, substantially as described. 2nd. In a mason's jointer, the combination with the frame or body thereof containing a mortar-receiving cavity, of a pointing lever, one end of which is located in the said cavity, and a spring for operating the lever in one direction, substantially as described. 3rd. In a mason's jointer, the combination with the body or frame thereof containing a mortar-receiving cavity, and having the inner edge of its outer end constructed with a longitudinal moulding groove, of a pointing lever located in part in the said cavity, and adapted to force the mortar therefrom, and to be engaged and operated by the hand of the user, substantially as described. 4th. In a mason's jointer, the combination with a doubly curved body or frame containing a mortar-receiving cavity, of a lever pivoted in the said frame or body and having one end adapted to force the mortar from the said cavity, and its other end adapted to be engaged for manipulation by the hand of the user, substantially as described.

**No. 57,375. Envelope. (Enveloppe.)**

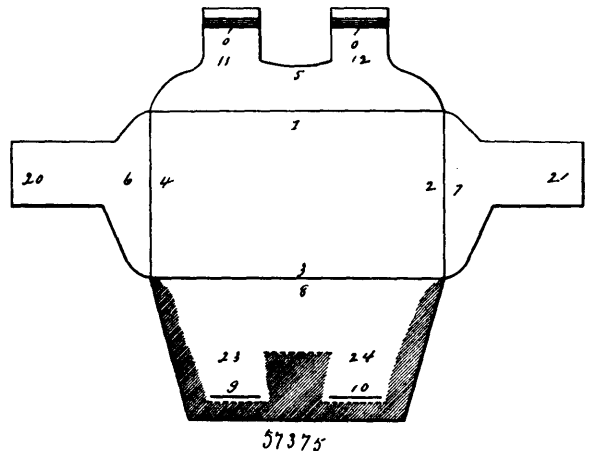

Charles Edgar Sackett, Danbury, Connecticut, U.S.A., 11th September, 1897; 6 years. (Filed 18th August, 1897.)

*Claim.*—1st. In an envelope the combination of cross bar arranged within the body of the envelope by elongation, overlapping and gumming any of its flaps, or by being secured to them, and a barb or projection arranged beneath the sealing flap of said envelope, so as to automatically lock itself over or catch beneath the said cross bar in the act of sealing, substantially as described and shown.

2nd. In an envelope, the combination of a slot arranged in the body of an envelope, a cross bar arranged behind it and forming therewith a pocket to which the slot gives entrance, a tongue arranged upon the sealing flap registering with said slot, and a barb or projection arranged beneath the tongue to lock over or catch beneath said cross bar, for the purpose set forth, and substantially as described and shown.

**No. 57,376. Glass-blowing Machine.**  
(Machine à souffler le verre.)

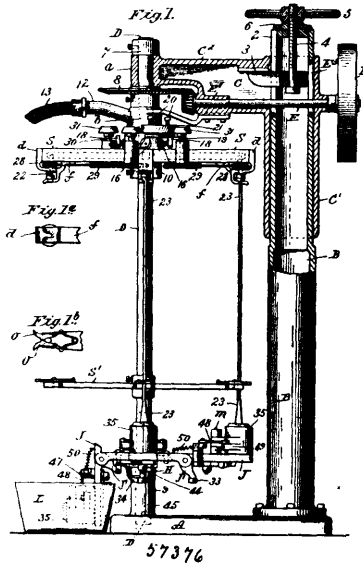

Noble Washington Hartman, Toledo, U.S.A., 11th September, 1897; 6 years. (Filed 31st July, 1897.)

*Claim.*—1st. In an automatic glass-blowing machine, a base, a single vertical column on the border of said base, a head supported on and extending at right angles from said column, and movable parts supported by said head, means for vertically adjusting said head, and means on said head and moving therewith for imparting motion to said movable parts, substantially as described. 2nd. In an automatic glass-blowing machine, a base, a single vertical column on the border of said base, a head supported on and extending at right angles to said vertical column, and adjustable vertically thereon, an air-conduit on said head communicating with an annular channel 11, therein, a main-shaft supported for rotation in said base and in said head, a driving mechanism for said shaft supported on said head, a spider S, attached to said shaft having air-passages in the hub and arms thereof communicating with said annular channel 11, revoluble air-valves in the hub of said spider, means for operating said valves for the intermittent discharge of air therethrough into the arms of said spider, under variable pressure, one or more moulds supported on said shaft, one or more blow-irons, means for supporting said blow-irons in engagement with said spider, and in operative relation to said moulds, and mechanism on said spider for rotating said blow-irons, combined and operating, substantially as set forth. 3rd. In a glass-blowing machine, a blow-iron, means for supporting said blow-iron, a pulley supported in said machine and connected with said blow-iron when the iron is in place, and another pulley supported in the machine, a band between the pulleys, and means for revolving the second pulley when the machine is operated, substantially as described. 4th. In an automatic glass-blowing machine, a base, a support or column B, secured on said base, a head C, supported adjustably on said column, and extending over said base, an air-conduit on said head communicating with an annular channel or passage 11, therein, a main-shaft having bearings in said base and said head, and mechanism on said head to drive the said shaft, the spiders S, and S', secured fast on said shaft, and one or more moulds secured to said shaft, one or more blow-irons supported on said spiders in operative relation to said spider S, and said moulds, one or more revoluble tubular chucks supported on the arms of said spider S, for engagement with said blow-irons, means for rotating said chucks induced by the rotary motion of said spider S, revoluble air-valves 16, in said spider S, controlling the supply of air from said passage or channel 11, to said spider, and means for intermittently operating said air-vessels, substantially as set forth. 5th. In an automatic glass-blowing machine, the head C, having a fixed semi-circular flange 21, thereon the revoluble shaft D, the spider S, attached to said shaft, one or more shafts 30, hung on said spider, having a pulley thereon for intermittent engagement with said flange, the tubular chucks 22, and means for imparting the intermittent rotary motion of said shafts 30, to said chucks, substantially as set forth. 6th. In an automatic

glass-blowing machine, the head C, having the air-conveying channel 11, therein, an air-conduit communicating with said channel, a parti-continuous cam-plate 19, attached to said head, means for vertically adjusting said cam-plate to varying planes, combined with the spider S, having air passages therein for communication with said channel 11, revoluble valves 16, each having an arm thereon for engagement with said cam-plate when they are opened, and a spring thereon acting to close the same when discharged from said plate, substantially as set forth. 7th. In a glass-blowing machine, the spider S, having the air passages 15, therein, one or more tubular chucks 22, hung to rotate on said spider in communication with said air passages, having a limited vertical movement, a spring 24\*, acting to move said chuck downward, combined with means for rotating said chucks, one or more blow-irons, and means for the temporary engagement of said chucks and blow-irons, whereby they have coinciding rotary movements, substantially as set forth. 8th. In an automatic glass-blowing machine, sectional moulds, means for supporting, rotating, and manipulating the moulds, comprising a main-shaft, means for supporting and rotating said shaft, a hub H, having one or more radially extending arms whose extremities are slotted to form the parallel arms h, h, a mould-carrier J, pivotally hung between said arms h, a depending arm J', on said carrier J, a spring-actuated latch 36, engaging the inward extremity of said carrier, whereby the latter is temporarily retained in a horizontal position, combined with a latch-tripping arm 40, and a mould-carrier elevating arm 34, substantially as described. 9th. In an automatic glass-blowing machine, sectional moulds, and means for operating and closing the said moulds consisting of a rotatable main-shaft, mould-carriers secured thereto, on which said mould sections are pivotally secured, two crank-arms 43 and 47, pivoted to one side of said mould-carrier and extending transversely there across and moving together as one arm, one above and the other below the mould-carrier, one of said arms being pivotally connected by arms 48, to each half of said mould, and a spiral spring secured to said crank-arm and to said mould-carrier, for retracting said arm, and the other of said arms engaging a trigger 41, whereby said moulds are locked in a closed position, a post 45, for disengaging said trigger, a fixed cam 52, and a roll 51, pivoted to said arm 47, engaging with said cam 52, for closing said mould, and means for dipping said moulds, substantially as described. 10th. In an automatic glass-blowing machine, a rotary main-shaft D, means for supporting and dipping the moulds thereof consisting of a hub H, secured to the rotating main-shaft D, said hub having a series of arms h, thereon, mould-carriers J, hinged to the arms for movement in a vertical plane, spring latches supported to said hub H, and engaging normally with a part of said mould-carrier, an arm on a fixed part of the machine for retracting said latch, a downwardly projecting arm on said mould-carrier for bearing against a suitably formed cam-surface, whereby said mould is permitted to move slowly from a horizontal up to a perpendicular position, and from a perpendicular to a horizontal position, combined with means for opening said moulds, and means for supporting and rotating said main-shaft, substantially as set forth.

**No. 57,377. Window Sash and Door Lock.**  
(Arrête fenêtre et porte.)

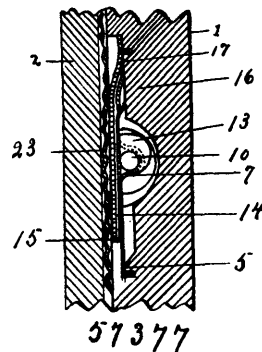

Allen Paul Heidt, Bay Shore, New York, U.S.A., 13th September, 1897; 6 years. (Filed 9th August, 1897.)

*Claim.*—1st. In a lock, the combination with a hinged locking-plate, of a ribbon-spring having one end fixed and the other free end bearing on said plate, whereby the latter is normally kept retracted, a spindle, and a cam carried by the spindle which is adapted to engage with and move said locking-plate. 2nd. In a lock, the combination with a base-plate provided with a slit, of a locking-plate having a bent hinge which is received in said slit, a spring for keeping the free portion of the locking-plate normally retracted, a spindle, and a cam carried by the spindle which is adapted to move the locking-plate. 3rd. In a lock, the combination with a base-plate provided with depressions serving as bearings and also provided with a slit, of a locking-plate having a bent hinge received in said slit, a spindle journaled in the bearing of the base-

plate, a cam carried by the spindle which lies in the opening in the base-plate and is adapted to move the locking-plate, and a ribbon-spring having its free ends pressing against the locking-plate.

**No. 57,378. Live Stock Feeding and Watering Device.** (*Appareil à abreuver le bétail.*)

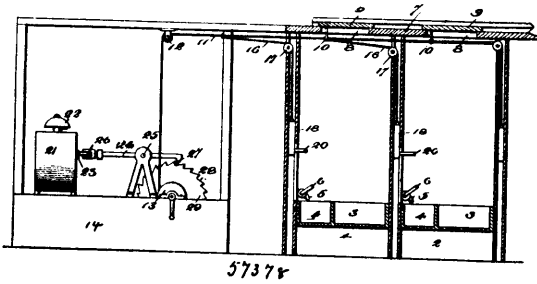

Nicholas Reuter, Chicago, Illinois, U.S.A., 13th September, 1897; 6 years. (Filed 20th August, 1897.)

*Claim.*—1st. In a device of the character described, the combination with a manger or suitable receptacle, of a counter-weighted feed door, automatic tripping mechanism connected therewith, a water receptacle provided with a controlling cock, and co-operative mechanism carried by the cock and counter-weight, substantially as specified. 2nd. In combination with feed and water receptacles, of a feed door, a cock designed to control the water supply, a counter-weight connected with the feed door and designed to open or close the cock, tripping mechanism operatively connected with the feed door, and timing mechanism designed to permit the tripping of the tripping mechanism, substantially as specified. 3rd. In a device of the character described, the combination with feed and water receptacles, of sliding feed doors, a cock designed to control the water supply and provided with a valve lever, a counter-weight connected with the feed door, and provided with a projecting lug designed to actuate the valve lever, a flexible piece connected with the feed door, a drum designed to receive said piece, tripping mechanism operatively connected with the drum, and timing mechanism operatively connected with the tripping mechanism, substantially as specified. 4th. In a device of the character described, the combination with feed and water receptacles, of a feed door and cock provided with a valve lever, a counter-weight connected with a door and provided with a projecting lug designed to actuate the valve lever and drum, a tripping lever designed to control the movement of said drum and provided with a slotted sleeve, a time piece and a rotatable key designed to be actuated by the time piece and to engage the slot in said sleeve, and a flexible piece wound around the drum and connected to the feed door, substantially as specified.

**No. 57,379. Chair Seat.** (*Siège de fauteuil.*)

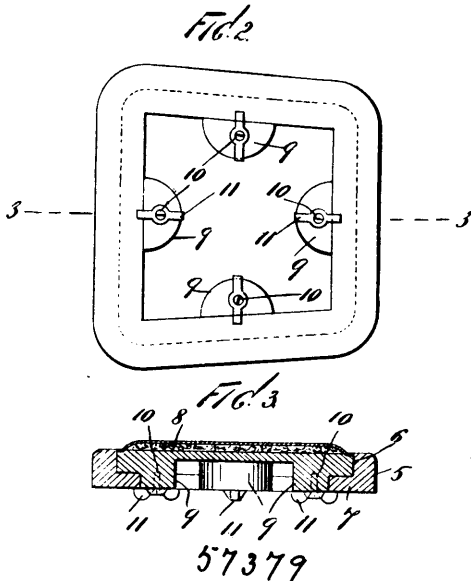

Andrew Jackson King, New York, State of New York, U.S.A., 13th September, 1897; 6 years. (Filed 20th August, 1897.)

*Claim.*—1st. A seat for chairs comprising a frame, and a seat proper mounted therein, and detachable therefrom, said seat proper

being provided with downwardly directed shoulders or projections which pass through the bottom of the frame, and which are provided with thumb nuts which are adapted to be turned so as to engage with the bottom of said frame, substantially as shown and described. 2nd. A chair provided with a seat consisting of a frame in which is formed an opening, and a seat proper mounted in said opening, and detachable from said frame, said frame being provided at the bottom of said opening with inwardly directed flanges on which the seat proper rests, and said seat proper being also provided with downwardly directed lugs or projections which extend downwardly to the bottom of the frame, and which are provided with pivoted catches which are adapted to be turned so as to engage with the bottom of said frame, substantially as shown and described.

**No. 57,380. Hose Coupler.** (*Joint de boyaux.*)

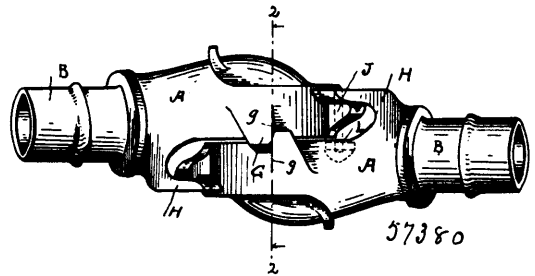

Joseph Redfern, Willmerding, Pennsylvania, U.S.A., 13th September, 1897; 6 years. (Filed 12th August, 1897.)

*Claim.*—1st. A coupling of the class described, provided with a lug extending at a right angle to the face of the coupling, and projecting beyond the same, and having a square face at right angles to the face of the coupling, located at such a point as to abut against a similar lug upon an adjacent coupling, substantially as specified. 2nd. A coupling of the class described, provided with a wing having a groove upon its under face concentric with the opening in said face, a reclining lip diametrically-oppositely disposed, and having a rib on its outer face concentric with the opening in the face of the coupling, and a lug between the wing and lip and projecting at right angles to the face, and extending beyond the same, substantially as described. 3rd. A gasket for an air-brake hose coupling, the same having a tapered outer wall, an annular depression upon its inner wall, and a split spring ring adapted to be seated in said depression, substantially as described. 4th. The combination with the coupler having an annular socket with undercut wall, of a gasket having a correspondingly-bevelled outer wall fitting said socket and projecting beyond the face of the coupling, and provided upon its inner wall with an annular depression, and a split spring ring seated in said depression, as set forth.

**No. 57,381. Combined Street-Sweeper and Loader.** (*Balayeuse et receptacle pour rues.*)

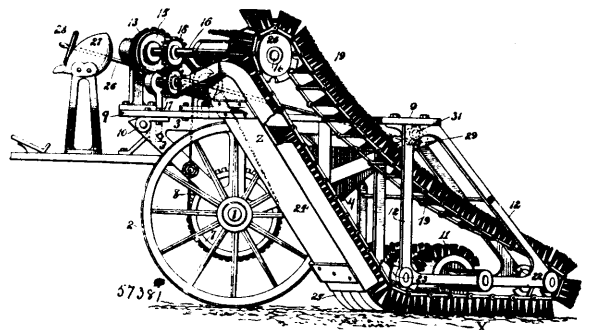

John Ambrose Hanlon, Brooklyn, New York, U.S.A., 13th September, 1897; 6 years. (Filed 20th August, 1897.)

*Claim.*—1st. In a street-sweeper and loader, the combination with a frame and ground-wheels, a rotating broom arranged obliquely to the line of draft, and a conveyer chute also arranged obliquely to the line of draft, and substantially at right angles to the broom-axis, of an endless elevator and conveyer arranged in the same vertical plane with the chute, and having a horizontal portion extending back of the rear end of the broom, whereby, in the forward movement of the sweeper and loader the horizontal portion of the conveyer is drawn over the surface in a path oblique to its own movement, substantially as set forth. 2nd. In a street-sweeper and loader, the combination with a frame and ground-wheels, of a rotating broom arranged obliquely to the line of draft, a chute arranged obliquely to the line of draft, and having its lower end laterally out of the path swept, an endless-chain elevator and conveyer arranged in the same vertical



plane with the chute, said elevator and conveyer having a horizontal portion adjacent to the rear end of the broom, and extending back of the axis of the same, and a side-guard to said conveyor at the side thereof opposite to the rotating broom, whereby the apron of the chute is removed from the path to be swept, substantially as set forth. 3rd. In a street-sweeper and loader, the combination with the frame, and the oblique rotating broom, of the endless conveyor and elevator 19 and the chute, said conveyor and elevator having L-shaped brushes 21, one branch of such brush extending transversely of the elevator to form a flight, and the other branch extending along the outer side of the elevator to form a side-guard, substantially as set forth. 4th. In a street-sweeper and loader, the combination with a supporting frame and wheels, of a rotating broom arranged with its axis oblique to the line of draft, an endless-chain elevator and conveyor arranged in a vertical plane which is also oblique to the line of draft, said conveyor and elevator having a horizontal portion which sweeps the ground and extends back of the rear end of the broom, whereby the transverse flights of the conveyor are presented obliquely to the line of draft, a side-guard for said conveyor on the side opposite to the broom and oblique to the line of draft, and the chute for the upright portion of the conveyor, substantially as set forth. 5th. A street-sweeper and loader provided with a rotating broom, a moving conveyor and elevator for the sweepings, and a bin to receive the latter when elevated, and having a lower frame on which said bin and the driving-shaft is mounted, an upper frame on which the broom, the elevator and the counter-shaft for driving same is mounted, said frames being hinged together as described, and means, under control of the driver, for elevating said upper frame, substantially as set forth. 6th. In a street-sweeper and loader, the combination with a supporting frame and a chute 24, of an endless conveyor and elevator provided with flights formed of brushes, and with side-guards on each flight also formed of brushes, said conveyor having a horizontal portion X, substantially as set forth. 7th. In a street-sweeper and loader, the combination with a supporting frame and ground-wheels, with or without a rotating broom oblique to the line of draft, of the endless conveyor and elevator arranged obliquely to the line of draft and in a vertical plane, and a chute for the upright portion of the elevator, said conveyor and elevator having flights and side-guard portions of an L-shape, whereby in moving over the surface obliquely to the line of draft these latter form sweepers and pockets, substantially as set forth.

**No. 57,382. Foot for Cutting Corn, Sugar Cane, etc.**  
(*Coupe-blé d'inde, etc.*)

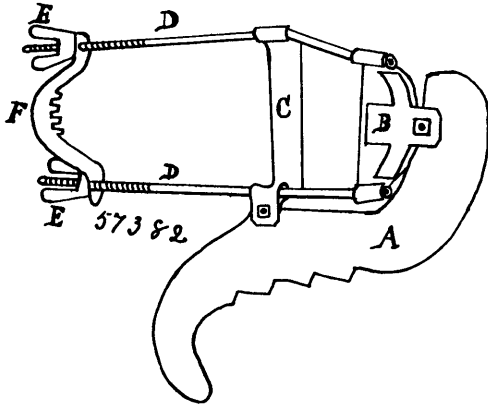

Jackson Johnson, Norham, Northumberland, Ontario, Canada, 13th September, 1897; 6 years. (Filed 30th July, 1897.)

*Claim.*—1st. The combination of a knife A with a clamp attached to the foot, as shown in figures 1 and 2, substantially as and for the purposes hereinbefore set forth. 2nd. The attaching of an implement to the foot, substantially as and for the purposes hereinbefore set forth.

**No. 57,383. Heel Plate.** (*Plaque pour talons.*)

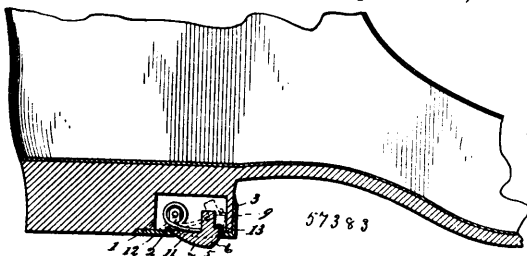

George Elbridge Swan, Beaver Dam, Wisconsin, U.S.A., 13th September, 1897; 6 years. (Filed 22nd July, 1897.)

*Claim.*—1st. A heel plate for the purpose described, having a spring cushion which, during compression, has a forward and upward movement, for the purpose described. 2nd. The combination with a plate having parallel ears and a central slot, of a slug having an inclined wearing face thicker at its forward end than at its rear end, and a spring for normally holding the thicker end of said slug projected through the slot of the plate, substantially as set forth. 3rd. The combination with a plate having parallel ears and a central aperture, of a slug projecting through the aperture, a spring secured between said ears and provided with a loop, said slug having a stud projecting upwardly through the loop and provided with laterally projecting stop ears, substantially as shown and described.

**No. 57,384. Air Brake Piston Remover.**

(*Appareil à extraire les tiges de frein atmosphérique,*)

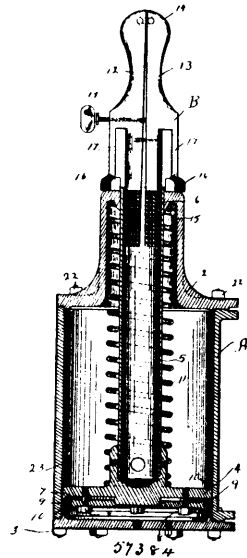

Charles Edwin Shearwood, St. Paul, Minnesota, U.S.A., 14th September, 1897; 6 years. (Filed 23rd August, 1897.)

*Claim.*—1st. In a clamp of the class described, in combination, the clamp members adapted to be inserted into the piston-rod sleeve, the stops or shoulders relatively fixed with relation to the jaws of said members, for engaging the cylinder-head, and the means for expanding said members so as to cause their jaws to tightly grip said sleeve and lock said sleeve and cylinder-head together. 2nd. In a device of the class described, in combination the similar clamp members adapted to be inserted into the piston-rod sleeve, the fixed stops carried by each of said clamp members for engaging the cylinder-head, the hinged connection for said clamp members, and the means for expanding them so as to cause their jaws to grip said sleeve, and lock said sleeve and cylinder-head together. 3rd. In an air-brake-piston remover, the combination of the pair of clamp members, their jaws being adapted to engage the piston-rod sleeve, the means upon each of said members for independently engaging the cylinder-head, the hinge connection for said clamp members, and the transverse screw carried by one member and engaging the other for separating the jaws of said members. 4th. In a device of the class described, the pair of similar clamp members having the faces of their jaws roughened, the shoulder upon each of said members adapted to engage the cylinder-head, the hinged connection for said clamp members, and the means for turning said members upon their hinge, so as to separate their jaws and cause them to engage the piston-rod sleeve, whereby said clamp is fixed to said sleeve, and relative outward movement of the cylinder-head prevented by said shoulder. 5th. In an air-brake-piston remover, the combination of the similar clamp-members adapted to engage the piston-rod sleeve, the hinged connection for said clamp members, the exterior relatively fixed shoulder or stop carried by each of said members, and abutting against said cylinder-head, the notch between each of said stops and its members to receive the projecting end of the piston-rod sleeve, and means for separating said members.

**No. 57,385. Self-Regulating Injector.** (*Injecteur.*)

Ludwig Ahrbecker, Hanover, Prussia, Germany, 14th September, 1897; 6 years. (Filed 23rd August, 1897.)

*Claim.*—1st. An injector, comprising a body having a water supply chamber extending laterally from one end thereof, and a steam supply and chamber at the adjacent end thereof, a water outlet at the opposite end thereof and adjacent nozzle chamber, a double pair of steam jet and water nozzles, a back pressure valve, a bi-passage leading from the force jet to the force nozzle chambers,



and a pressure valve to control said passage, substantially as described. 2nd. An injector, comprising a body having a steam

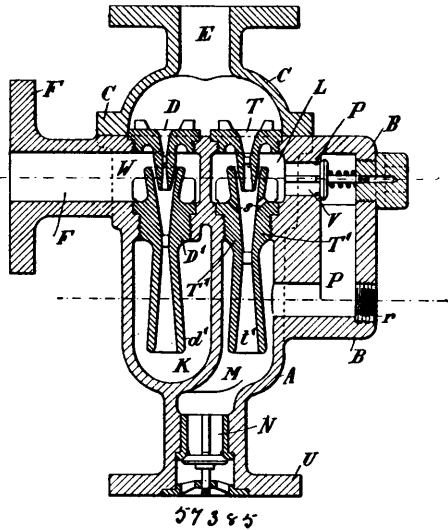

chamber, water inlet and discharge chambers, into mediate steam and water chambers arranged in pairs in adjacent parallel axis, lift and force nozzles supported in said chambers, the force nozzle of one set having apertures leading from the middle of its conduit to the upper and adjacent jet chamber, substantially as described. 3rd. An injector, comprising a body having a steam chamber, water inlet and discharge chambers, intermediate jet lift and force chambers arranged successively, a set of jet lift and force nozzles, the said force nozzle having apertures leading from the middle of its conduit to the adjacent jet chamber, a bi-passage leading from the said jet chamber to the force nozzle chamber, and a pressure valve to control said passage, substantially as described. 4th. An injector, comprising a body having division walls forming a water supply chamber, a lift jet chamber, a lift nozzle chamber lying in the axis of said jet chamber and having a crescent-shaped cross-section side channel leading from the upper end thereof, a force jet chamber and force nozzle chamber arranged in the same axis, a valve-controlled discharge conduit leading from the latter, and the double set of nozzles fitted in seats in the walls of said chambers, substantially as described.

**No. 57,386. Weather Vane. (Girouette.)**

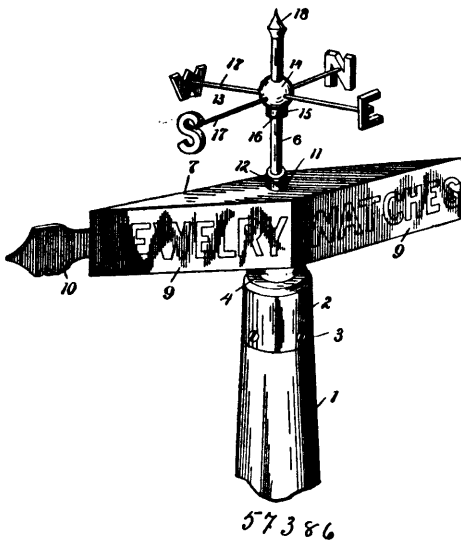

William Kinehan, Bedford, Quebec, Canada, 14th September, 1897; 6 years. (Filed 23rd August, 1897.)

*Claim.*—1st. A device of the class described, comprising a supporting spindle, and a vane mounted thereon and provided with advertising space, substantially as set forth. 2nd. A device of the class described, comprising a supporting spindle, a vane mounted thereon and provided with advertising space, and an indicator for the cardinal points of the compass also mounted upon said spindle and adapted to be retained in a fixed position thereon, substantially as

described. 3rd. A device of the class described, comprising a cap, a supporting spindle carried thereby and projecting upwardly therefrom, and a vane mounted on said spindle and provided with advertising space, substantially as described. 4th. A device of the class described, comprising a cap, a supporting spindle carried thereby and projecting upwardly therefrom, a vane mounted thereon and provided with advertising space, and an indicator for the cardinal points of the compass also mounted upon said spindle and adapted to be retained in a fixed position thereon, substantially as described. 5th. A device of the class described, comprising a supporting spindle, and a vane mounted thereon, the sides of said vane converging at each of its ends to provide a series of advertising spaces, substantially as described. 6th. A device of the class described, comprising a supporting spindle, a vane mounted thereon, the sides of the said vane converging at each of its ends to provide a series of advertising spaces, and an indicator for the cardinal points of the compass also mounted upon said spindle, substantially as described. 7th. A device of the class described, comprising a supported spindle, a vane mounted thereon, the sides of said vane converging at each of its ends to provide a series of advertising spaces, and an indicator for the cardinal points of the compass also mounted upon said spindle, said indicator comprising a body arranged to slide on the spindle, and provided with a depending neck, a binding screw passing through said neck and adapted to impinge against the spindle for retaining the body in fixed position thereon, radially-projecting arms carried by the body, and letters carried by said arms and denoting the cardinal points aforesaid, substantially as described. 8th. A device of the class described, comprising a supporting spindle, a vane mounted thereon, the sides of said vane converging at each of its ends to provide a series of advertising spaces, and an indicator for the cardinal points of the compass also mounted upon said spindle, said indicator comprising a body arranged to slide on the spindle and provided with a depending neck, means carried by said neck for retaining the body in fixed position on the spindle, radially-projecting arms carried by the body, and letters carried by said arms and denoting the cardinal points aforesaid, and a removable head mounted upon the upper end of said spindle, substantially as and for the purpose described.

**No. 57,387. Barrel-making Machine.**

(Machine à faire les barils.)

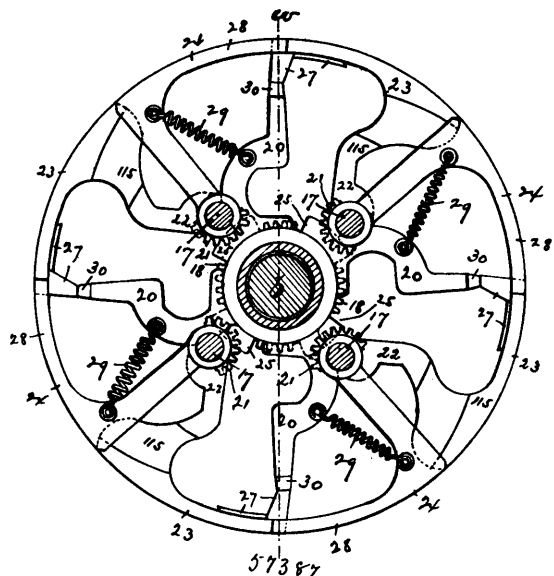

Robert Nawrath, Newark, New Jersey, U.S.A., 14th September, 1897; 6 years. (Filed 27th August, 1897.)

*Claim.*—1st. In a barrel machine, the combination with the sweeps, feed devices and means for operating the same, of a shaft b,

and a collapsible frame, comprising two sets of lever like segments adapted to be turned pivotally to bring the segmental portions to or from a position to form a complete circle to receive the staves, the segments of one set alternating with those of the other an transmitting movement thereto, and means for turning said lever like segments and holding them in position, substantially as set forth. 2nd. In a barrel machine, the combination with the sweeps, feed devices and means for operating the same, of a shaft *b*, and a collapsible frame, comprising two sets of lever like segments, the segments of one set projecting into engagement with the segments of the other set and adapted to raise the same to form a complete circle therewith, means for operating said segments and means for drawing the second set of segments, adapted to be operated upon by the first set, to the folded or collapsed relation or position, and means for supporting said segments in their distended positions, substantially as set forth. 3rd. In a barrel machine, the combination with the sweeps and feed devices and means for operating the same, of a shaft *b*, discs 5, 5, series of shafts 17, segments fulcrumed and movable oppositely on said shafts 17, the segments of one set being movable under the power of the others and means for operating said parts, and star wheels, the arms or rays of which underlie the segments to hold them in distended positions, substantially as set forth. 4th. In a barrel machine, the combination with the sweeps and means for operating the same, of a shaft *b*, discs 5, sleeve 6, shafts 17, lever-like segments, gear wheels for turning said segments simultaneously and means for holding said segments in distended positions, substantially as set forth. 5th. In a barrel machine, the combination with the sweeps and means for operating the same, of a shaft *b*, discs 5, keyed to the shaft, a sleeve between said discs, loose on said shaft, a gear wheel keyed to said sleeve, means for turning said sleeve, a series of shafts 17, having bearings in said discs, and having segment levers thereon, means for turning said segment levers on said shafts, star wheels supporting said segment levers, and means for locking said segment levers, substantially as set forth. 6th. In a barrel machine, the combination with the sweeps and means for operating the same, of shaft *b*, discs 5, 5, keyed to said shaft, a sleeve arranged loosely on said shaft between said discs, a gear wheel 7, keyed to said sleeve, a pinion 8, arbor 9, and internally geared segment fast upon said arbor, a gear wheel 12, within said segment and having a dentate hub, gear wheels 18, with missing teeth, two sets of lever-like segments, one set of which has segmental arms provided with teeth which engage the teeth of said gear-wheel 18, and the other set engaging the first and raised or distended thereby, springs for drawing the second set of segments to their collapsed positions, and means for supporting said segments in their said distended positions, substantially as set forth. 7th. In a barrel machine, the combination with the sweeps and means for operating the same, and a suitable feeding device, of a shaft and a collapsible frame thereon, adapted when distended to receive the staves, said frame including a series of pivotal segments having segmental portions co-operating to form a circle on which the staves are arranged, and inwardly extending arms or portions providing pivotal bearings, the alternate members of the series having segmental arms 22, geared to a common source of power, and having extensions engaging the other members of the series to operate the same, said common source of power, and means for operating said parts, all substantially as set forth. 8th. In a barrel machine, the combination with a central shaft *b*, and a series of shafts 17, arranged therearound, of sleeve arranged on said central shaft, a gear wheel 18, with missing teeth, two series of segments pivoted and movable oppositely on said shafts 17, the segments of one of said series having cogs 21, adapted to mesh with the teeth of the gear wheel 18, and having lateral projections 27, adapted to extend under the segments of the other series and to slide thereon to raise the said other series of segments to positions to form therewith continuous circular stave bearings, means in train with said sleeve and cogged segments for operating the latter, and supporting rays, adapted to bear against the inner sides of said segments to hold the same firmly in distended positions, and locking means adapted to engage said cogged segments to lock the same when the cogs thereof pass from meshed relation with the gear wheel having missing teeth, whereby the said gear wheel may continue to turn with the sleeve without operating the segments to bring the star wheel 20 into supporting relation, substantially as set forth. 9th. In a barrel machine, the combination with the supports *c*, separable sweeps and the collapsible frame, of a shaft 40, crank arms 41, connecting rods 42, connecting said arms with supports *c*, the latter being connected to one of said sweeps, connecting rods  $g^{11}$ , connecting the said supports *c*, to one end of walking beams  $g^{11}$ , connecting rods  $g^1$ , connecting the other ends of said walking beams  $g^{11}$ , with the sweeps *h*, and means for operating said parts, substantially as set forth. 10th. In a barrel machine, the combination with the separable sweeps, and means for operating the same, of upper and lower catches, for locking the sweeps together, a lever for operating the catches, and connections of said catches and lever, substantially as set forth. 11th. In a barrel machine, the combination with the sweeps and collapsible frame and train of levers, rods and shaft to effect opposite movement of said sweeps, of a worm wheel 46, arranged on said shaft and having shifting pins 63, engaging a bell crank lever 60, for operating a power belt shifter to cause a stopping of the power by which said worm wheel is operated and the collapsible frame and sweeps are collapsed and opened, or vice versa, substantially as set forth. 12th.

In a barrel machine, the combination with the sweeps and collapsible frame, and a train of mechanism to effect opposite movements of said sweeps automatically, of a belt shifter operated by shifting pins arranged on or in connection with said train of mechanism, whereby said train can be operated in a given direction a limited distance or period only, and a hand lever and connection with said shifter to give a return shift to said operating means, substantially as set forth. 13th. In a barrel machine, the combination with the sweeps and means for operating the same oppositely, said means including the shaft 40, of a gear wheel 46, arranged on said shaft 40, in train with intermediate gear wheels 47, said gear wheels 47 meshing with the gear wheel 49, of the sleeve 16, the said sleeve 16 having clutch member 50, engaging a co-operating dentate hub 15, of a collapsible frame and said collapsible frame arranged within the sweeps, said parts being arranged and adapted to operate substantially as set forth. 14th. In a barrel machine, the combination with the collapsible frame and its rotary shaft, of a clutch arranged on said shaft, one of the members of which clutch is a dentate hub of a gear wheel 12, and an interiorly cogged segment attached to the collapsible frame and operated by said gear wheel 12, and means for operating the clutch substantially as set forth. 15th. In a barrel machine, the combination with the collapsible frame and its rotary shaft, of a sleeve 6, loose on said shaft, gear wheels 18, with missing teeth, fast upon said sleeve, segmental stave supports 115, and 24, star wheels 20, locking arms 25, gear wheels 7 and 8, arbor 9, internally geared segment 11, fastened upon said arbor, a gear wheel 12, engaging the said segment 11, and having a dentate hub 15, a clutch member 50, and means for operating said clutch members, substantially as set forth. 16th. The improved barrel machine, in which is combined a collapsible frame and its shaft *b*, and sweeps separable from one another, a power shaft 40, and means for operating the same, and separate trains of mechanisms, one of which connects said shaft 40 with said collapsible frame, and the other with said sweeps, whereby when power is applied to said shaft, the said collapsible frame and the separate sweeps will be operated simultaneously, substantially as set forth. 17th. The improved barrel machine, in which is combined a collapsible frame and its shaft *b*, carrying said frame, and means for collapsing said frame, said collapsing means being partly arranged in said frame and partly arranged on said shaft, independent of said frame, means for rotating said shaft, means for oscillating said collapsing means, and means for bringing the separate parts of the collapsing means into clutched relation, substantially as set forth.

#### No. 57,388. Gate. (Barrière.)

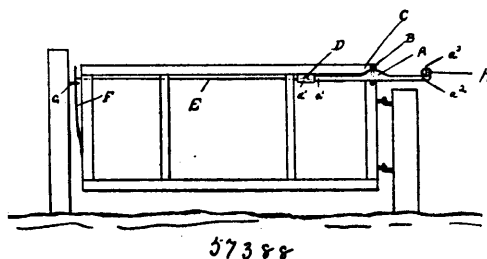

Harvey Storage, Weston, Ontario, Canada, 14th September, 1897; 6 years. (Filed 25th August, 1897.)

*Claim.*—1st. In a gate hung at one end, the lever A substantially as set forth and described. 2nd. In a gate hung at one end, the lever A working on a pivot or bracket B in combination with a guide and block D and  $d^1$ , substantially as set forth and described. 3rd. In a gate hung at one end, the lever A working on a pivot or bracket B in combination with a guide and block D and  $d^1$ , in combination with a cord or rod E attached to a spring or fastener F substantially as set forth and described. 4th. In a gate hung at one end, the lever A working on a pivot or bracket B in combination with a guide and block D and  $d^1$ , in combination with a cord or rod E attached to a spring or fastener F, in combination with one or more rods H, substantially as set forth and described. 5th. In a gate hung at one end, the lever A working on a pivot or bracket B in combination with a guide and block D and  $d^1$ , in combination with a cord or rod E attached to a spring or fastener F, in combination with a cord or cords J, substantially as set forth and described.

#### No. 57,389. Sash Balance and Fastener.

(Arrête-croisèle.)

James H. Wallace and Arthur G. Hilton, both of Fort Fairfield, Maine, U.S.A., 14th September, 1897; 6 years. (Filed 25th August, 1897.)

*Claim.*—1st. In a sash balance and fastener, a sash provided with a rack of teeth at its edge, a drum having circumferential teeth to engage the said rack and journaled to rotate in the casing at the edge of the sash, a spring connected with the drum to rotate it as a balance for the sash, two detents engaging the teeth of the drum in opposite directions, springs for the detents, and a pin having a tapering enlargement arranged to slide between the detents,

and at right angles to the plane of movement of the same, substantially as described. 2nd. A sash balance, toothed, spring drums

engaging with one end of said tubular shaft, of means, substantially as shown and described, for revolving the drill shaft, a shaft driven

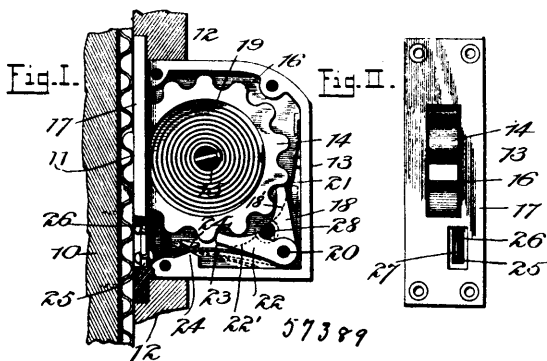

journalled in a case which is slotted through its face and provided with shouldered notches in the slot, a detent hung to engage the teeth of the drum, a spring for the detent, having midway bearings in the case, and a handle projecting into the said slot to engage either of the said notches, substantially as described.

**No. 57,390. Horizontal Sawing Machine. (Scierie.)**

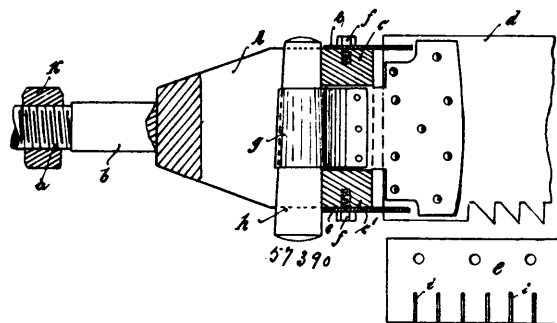

Otto Wilhelm Lau, Wesselbrun, Holstein, Germany, 14th September, 1897; 6 years. (Filed 23rd August, 1897.)

*Claim.*—1st. The combination of a body portion, a saw blade having an eye engaged with the body portion, a key fitted in the eye and bearing against the body portion and a plate secured on the body portion and having a slot receiving a portion of the saw blade. 2nd. The combination of a body portion having two cross pieces forming a space between which portions of saw blades may be projected, a key capable of engaging the cross pieces to hold a saw blade, and a slotted plate attached to the body portion and capable of receiving the saw blades in the slots thereof.

**No. 57,391. Drill. (Foret.)**

William J. Hatton, Escjanaba, Michigan, U.S.A., 14th September, 1897; 6 years. (Filed 23rd August, 1897.)

*Claim.*—1st In a drilling apparatus, a supporting frame consisting of independent uprights, fastening devices having vertical and lateral adjustment thereon, an adjustable cross bar connecting the uprights, and an adjustable socket carried by the cross bar, arranged to receive the drilling device, substantially as shown and described. 2nd. A support for a drilling device, consisting of uprights, sockets adjustable upon the uprights, fastening devices adjustably connected with said sockets, a cross bar adjustably attached to the uprights, a socket adjustable upon the cross bar, a standard which is a portion of the drilling device, a socket adjustable upon said standard, and a guide carried by the latter socket, all arranged for operation substantially as set for. 3rd. In a drilling device, the combination, with a support, a nut held to turn in said support, the means for turning the nut, of an exteriorly threaded tubular feed shaft passed through said nut and provided with a hand grip, a drill shaft mounted to revolve in the feed shaft, a tool holder at one end of the drill shaft, engaging with the end of the feed shaft, devices for preventing end movement of the drill shaft, and means substantially as described for driving the drill shaft, for the purpose set forth. 4th. A drilling device consisting of a standard, a nut held to turn in said standard and provided with an attach gear, an exteriorly threaded and hollow shaft received by the said nut, a drill shaft mounted to turn in the hollow shaft, having a head which engages with one end of the hollow shaft, and a driving mechanism for the drill shaft, as and for the purpose set forth. 5th. In a drill, the combination, with a standard, a nut held to turn in the standard, provided with an attached gear, an exteriorly threaded hollow shaft received by the said nut and provided with projections at its forward end, and a drill shaft held to turn in the hollow shaft, provided with a head

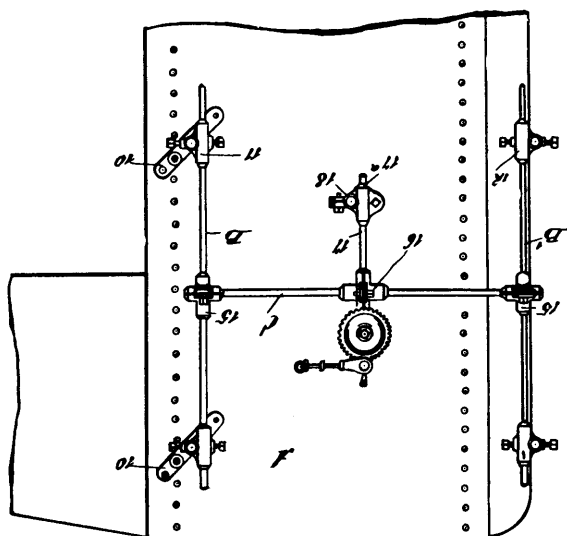

by said driving mechanism, mounted to turn and to have end movement in the said standard, and a gear connection between the driven shaft and the gear on the said nut, as and for the purpose set forth. 6th. In a drill, the combination, with a standard, a nut provided with an attach gear held to turn in the said standard, a tubular shaft exteriorly threaded, received by the said nut, a drill shaft held to turn in the tubular shaft, having a projection at one of its ends, forming a shoulder for engagement with the tubular shaft, and a ratchet and pawl device for turning the drill shaft, of a driven shaft mounted to turn and to have end movement in said standard or upright, a gear carried by the said driven shaft, a pinion carried by the ratchet and pawl driving mechanism, meshing with the said gear, a pinion splined upon the driven shaft, and a double gear, one surface of which double gear meshes with the said pinion and the other surface with the gear on the said nut, substantially as and for the purpose specified.

**No. 57,392. Cot. (Berceau.)**

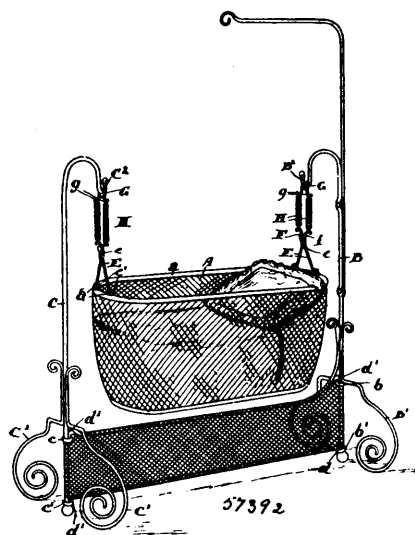

George Bryan Meadows, Toronto, Ontario, Canada, 14th September, 1897; 6 years. (Filed 23rd August, 1897.)

*Claim.*—1st. In a cot, in combination the supporting standards, the cot proper having an upper rim, eyes on the rim, the Y-shaped

braces hooked in such eyes and the depending springs hung from the hooked ends of the standards, as and for the purpose specified. 2nd. In a cot, in combination the supporting standards, the cot proper having an upper rim, eyes on the rim, the Y-shaped braces hooked in such eyes, the Y-shaped hooks having upper eyes, the double looped eyes and the double springs at each end, all arranged as and for the purpose specified. 3rd. In a cot, a frame comprising the standards B and C, the metal straps, sockets *b* and *b*<sup>1</sup>, and *c* and *c*<sup>1</sup>, and the central bracing panel D, having the end looks *d* and *d*<sup>1</sup>, designed to fit into the sockets, as and for the purpose specified. 5th. In a cot, in combination the supporting standards, the cot proper having an upper rim, a depending spring or springs hung from the hooked end of the standards and suitable means for connecting the lower ends of the spring or springs to the cot proper, as and for the purpose specified.

**No. 57,393. Cart for Military and other Purposes.**  
(Voiture à l'usage de la milice, etc.)

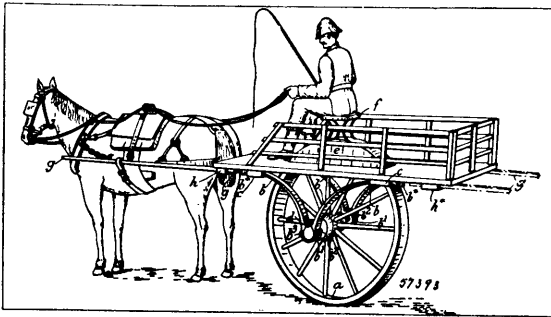

Harry Aubrey de Vere Maclean, London, England, 14th September, 1897; 6 years. (Filed 23rd August, 1897.)

*Claim.*—1st. A cart suitable for military, commercial, or pleasure purposes, having a single wheel which is detachable and arranged in the longitudinal axial line of such cart, substantially as described. 2nd. A cart having a single wheel which is detachable and is arranged centrally of the longitudinal axial line of said cart, and projecting (or not) through the floor thereof, substantially as described. 3rd. A cart having a single wheel which is detachable and is arranged centrally of the longitudinal axial line of such cart, and carried in brackets forming, at the same time, the bearings and springs for such wheel, substantially as described.

**No. 57,394. Bottle Closure.** (Fermeture de bouteilles.)

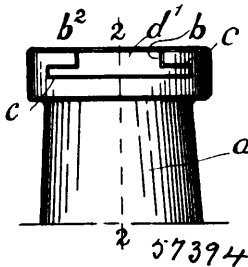

Peder K. Mannes, West Duluth, Minnesota, U.S.A., 14th September, 1897; 6 years. (Filed 25th August, 1897.)

*Claim.*—1st. A bottle having an opening in one wall of the mouth thereof, and having grooves formed in its interior walls, the grooves communicating with the opening, a closure-plate capable of extending through the opening and having its edges fitted within the groove of the mouth, the closure-plate having two recesses in its lower face, the recesses being in communication with each other by a groove, and a spring fitted within the groove and having its free ends respectively movable within the recesses so that the free ends of the spring may engage with the walls of the mouth of the bottle. 2nd. A bottle, the mouth of which has an opening running through the top edge of the mouth, the mouth also having an interior groove running horizontally around the mouth and communicating with the opening, a closure-plate slidable through the opening and capable of having its edges held by the groove in the mouth of the bottle, the plate having an upwardly-extending portion at one edge, such portion serving to fill the opening in the mouth of the bottle, and a spring pressed member carried by the closure-plate and engaging with an interior portion of the mouth of the bottle, whereby to hold the closure-plate in position during the integrity of that portion of the mouth of the bottle which is engaged by said spring-pressed member. 3rd. A bottle having an opening in the mouth thereof, and having interior grooves communicating with the opening, a

closure-plate slidable through the opening in the mouth of the bottle and having its edges capable of extending within the groove, and a spring-pressed member carried by the closure-plate and engaging an interior portion of the mouth of the bottle whereby to hold the closure-plate in place during the integrity of that part of the mouth of the bottle which is engaged by said spring-pressed member.

**No. 57,395. Thread Holder for Spools.**  
(Porte-fil pour bobines.)

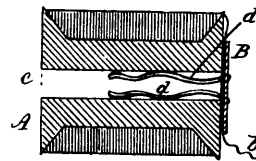
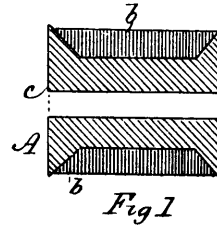

Lily Whitney, Burlington, Ontario, Canada, 14th September, 1897; 6 years. (Filed 25th August, 1897.)

*Claim.*—1st. In combination with a spool of thread, a disc having spring arms or their equivalent, attached to the same to hold the loose ends of the thread, substantially as specified. 2nd. The combination of the spool A, disc B and spring arms *d, d*, all substantially as and for the purpose specified. 3rd. The combination of the spool A, disc B, notch *e* in disc and spring arms *d, d*, all constructed to hold the loose end of spooled thread, substantially as described.

**No. 57,396. Grinding Machine for Mowing Machine Blades.** (Machine à aiguiser les lames faucheuses.)

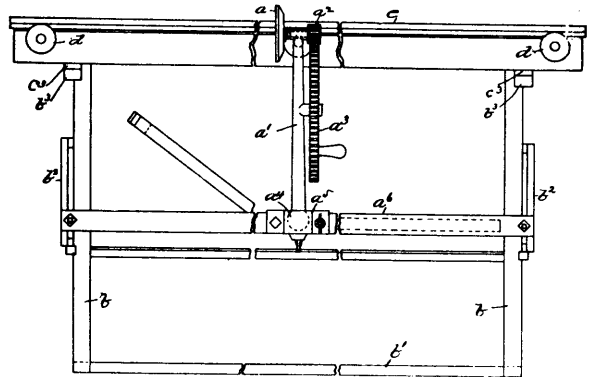

Horatio S. Beckwith, Fort Fairfield, Maine, U.S.A., 14th September, 1897; 6 years. (Filed 24th August, 1897.)

*Claim.*—1st. In a grinding machine, a table upon which the blade to be ground is supported having a cross bar, adjustably connected therewith, to which the grinding device is attached, substantially as described. 2nd. In an apparatus for grinding the guard plates of mowing machine finger bars, the combination of a grinding device having a grinding wheel, a supporting frame to which said grinding device is attached, a set of rollers and a support therefor mounted on said supporting frame, the finger bar supporting board *e* placed upon and supported by said rollers in a plane below the top of the grinding wheel, and constructed and arranged to receive upon it the finger bar with the fingers projecting beyond the front edge of said board so that any pair of fingers may astride the grinding wheel, and to permit said bar to be tilted thereon, so that its fingers may be raised to pass over the top of said grinding wheel, as said board

is moved along, substantially as described. 3rd. The combination with grinding devices, and a supporting frame thereof, of a set of rollers arranged in pairs, a support movable transversely on said frame work for stationarily supporting said rollers, a finger bar, supporting board mounted upon and supported by said rollers in a plane below the top of the grinding wheel and adapted to receive upon it the finger bar to be operated upon in a manner to permit said bar to be tilted thereon, and a guide strip upon the under side of said board adapted to co-operate with the stationarily supported rollers to guide the board in its longitudinal movement, substantially as described. 4th. In an apparatus for grinding the guard plates of moving machine finger bars, a grinding device having a grinding wheel, a supporting frame to which said grinding device is attached, a set of rollers arranged in pairs with a space between the rollers of each pair, a support for said rollers mounted upon said supporting frame, the finger bar supporting board *e* resting on said rollers having a guide strip *e*<sup>1</sup> upon its under side adapted to occupy the spaces between the rollers of each pair, said board being supported by said rollers in a plane below the top of the grinding wheel, and adapted to receive upon it the finger bar and to permit said bar to be tilted thereon, substantially as described. 5th. In an apparatus for grinding guard plates of moving machine finger bars, the combination with a grinding device having a grinding wheel and a supporting frame to which said grinding device is attached, of rollers *d*, a support for said rollers which is mounted upon said supporting frame consisting of a base *c* and side pieces *c*, *c*<sup>1</sup>, in which side pieces said rollers are journaled, and a finger bar supporting board *e* having a guide strip *e*<sup>1</sup> upon its under side which engages the rollers, substantially as described. 6th. In a grinding machine, a grinding device, a table consisting of a frame work to which said grinding device is attached, a set of rollers arranged in pairs with spaces between the rollers of each pair, a support for said rollers mounted on the frame work, the bar carrying board upon said rollers having a guide strip along its underside which enters the space between the rollers of each pair, substantially as described. 7th. In a grinding machine, a grinding device, a table consisting of a frame work having a pair of section supporting arms attached thereto by thumb screws, whereby said arms may be brought into position for use, when desired, and securely held in such position, substantially as described.

**No. 57,397. Boot and Shoe Lacing.**

(Lacement de chaussures.)

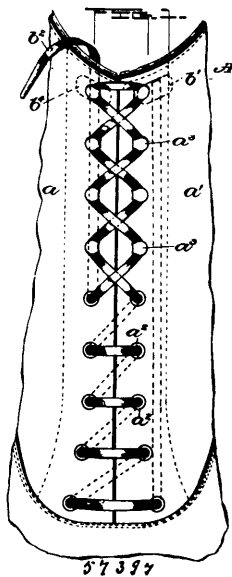

Horatio Oliver Whyman, Norfolk, Nebraska, U.S.A., 14th September, 1897; 6 years. (Filed 20th August, 1897.)

*Claim.*—1st. A boot and shoe having a series of eyelets arranged along the contiguous edges of its vamp and a series of hooks arranged along said edges above said eyelets, as is usual, and provided with a frictional securing device or clamp on its vamp, with a lacing having a loop of sufficient length to engage said series of hooks in the usual manner of cross-lacing a shoe and leave a slack, and having a portion extending from one leg of said loop through an upper eyelet and thence through other eyelets in the usual manner of overlacing, and having a portion extending from the other leg of said loop through an opposite upper eyelet, whereby when the shoe is applied to the foot the loop may be made to engage the series of hooks by passing alternately from hook to hook on opposite sides of the vamp and may be tightened about the hooks and held taut by drawing upon the latter portion of the lacing and by its engagement with said securing device, substantially as described. 2nd. A boot or shoe

having a series of eyelets arranged along the contiguous edges of its vamp and a series of hooks arranged along said edges above said eyelets, as is usual, and provided with a frictional securing device or clamp on the vamp, and with a lacing having a loop of sufficient length to engage said series of hooks in the usual manner of cross-lacing a shoe and leave a slack, and having a portion extending from one leg of said loop through an upper eyelet and thence through other eyelets in the usual manner of overlacing, and having a portion extending from the other leg of said loop through an opposite upper eyelet, thence through other lower eyelets, whereby when the shoe is applied to the foot the said loop may be made to engage the series of hooks by passing alternately from hook to hook on opposite sides of the vamp and may be tightened about the hooks and be held taut by drawing upon the latter portion of the lace and by its engagement with said securing device, substantially as described.

**No. 57,398. Lace Holder. (Porte-lacets.)**

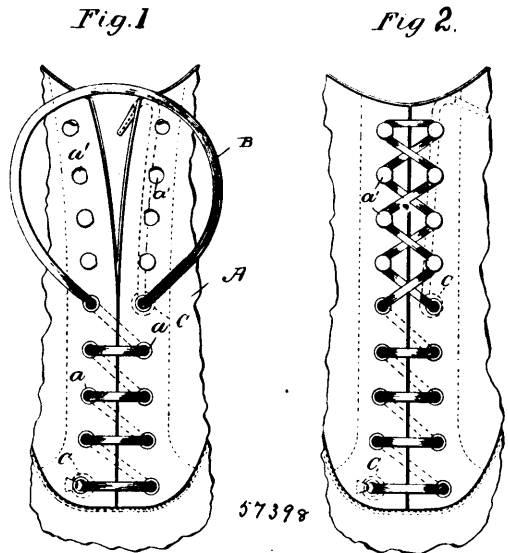

Horatio Oliver Whyman, Norfolk, Nebraska, U.S.A., 14th September, 1897; 6 years. (Filed 20th August, 1897.)

*Claim.*—1st. A lace-holding device consisting of a circular plate or disc having diagonally arranged intersecting slots therein, and a perforation or opening therethrough near said slots to receive and hold a lace or string, substantially as described. 2nd. A lace-holder comprising a plate having diagonally arranged intersecting slots therein, and an eye therethrough arranged in the space within the converging lines of said slots, substantially as described. 3rd. A lace-holder consisting of a disc having an eccentrically arranged opening perforation or eye therein, and an approximately trefoil-shaped opening adjacent to said eye, substantially as described. 4th. In combination with the lace-holder consisting of a plate having diagonally arranged intersecting slots therein, and an eye therethrough arranged in the space within the converging lines of said slots, a lace or string passing through said eye and slots, whereby the holder may be made fast at any desired point upon the string by tightening the latter in engagement with said eye and slots, substantially as described. 5th. A lace-holding device consisting of a suitable plate having a plurality of openings therethrough adapted to receive a lace or string for securing said device in a fixed position at any point along the length of the string, substantially as described.

**No. 57,399. Dumping Wagon. (Wagon à bascule.)**

Walter Lyman French, Brockton, Massachusetts, U.S.A., 14th September, 1897; 6 years. (Filed 20th August, 1897.)

*Claim.*—1st. A truck *A* having a series of friction rolls *d*, *d*, and a series of friction rolls *d*<sup>1</sup>, *d*<sup>1</sup>, all of which project above its upper surface, the rolls *d*<sup>1</sup>, *d*<sup>1</sup>, also projecting beyond the rear of the truck, in combination with a body *C*, a means of alignment for the latter during its movements forward and back on the truck, and while being tipped away from and returned to its seat thereon, and means for holding and locking the body in its horizontal or loading position, constructed to operate as described. 2nd. In combination, a wagon truck *A* with its friction rolls *d*, *d*, *d*<sup>1</sup>, *d*<sup>1</sup>, and guide rolls *h*, *h* located on a common axis *e*, a wagon body *C*, having projecting from its underside guide rods *l* which act in conjunction with the guide rolls *h*, *h* to preserve the alignment with the truck, of the body in all its movements, and devices for holding and locking the body forward in its horizontal or loading position, substantially as set forth. 3rd. The truck with its friction rolls *d*, *d*, *d*<sup>1</sup>, *d*<sup>1</sup>, and guide rolls *h*, *h*, and

with transverse rods *i i* near its forward end, in combination with the body having guide rods *l l*, and with hooks *n n* to engage with

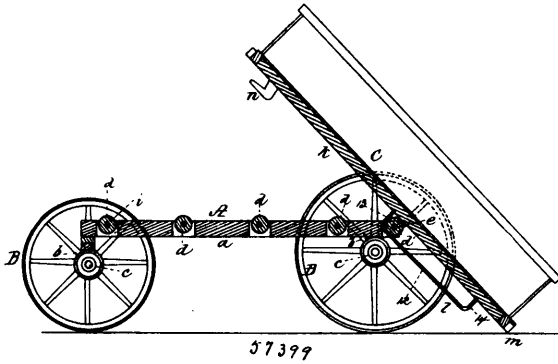

the rods *i i*, and a bolt *p* for locking the body in its horizontal position, as specified. 4th. The truck with its longitudinal stringers *a*, the friction rolls *d, d'*, the guide rolls *h h*, their axial rod *e*, and the rods *i i*, in combination with the body having longitudinal sills *k*, corresponding in number to that of the stringers, and sheathed with metal on their under sides, guide rolls *l l*, a pair of wedge-shaped hooks *n n*, and a vertical bolt *p* for keeping the body in its loading position, as described.

**No. 57,400. Steam Boiler. (Chaudière à vapeur.)**

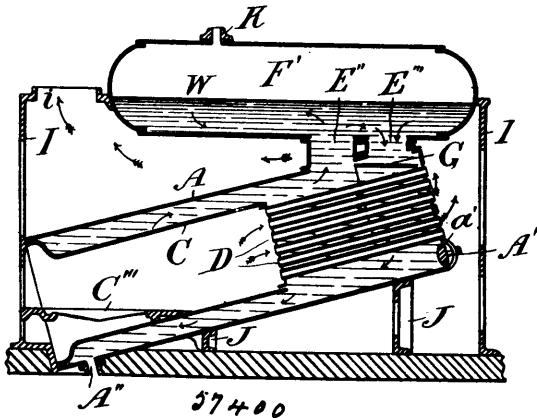

Joseph Alexander Mumford, Hantsport, Nova Scotia, Canada, 14th September, 1897; 6 years. (Filed 18th August, 1897.)

*Claim.*—1st. In a steam boiler, the combination of a shell having a considerable inclination rising from the front, a tubular fire box in the front or lower part of said shell, and completely surrounded by water, fire tubes in the rear or elevated end of said shell, a trunk at the upper rear end of said shell forming a steam reservoir or connection with a steam reservoir such as a dome or drum, and means of communication between the lower part of said steam reservoir with the lower part of the shell, such as trunks or tubes, substantially as set forth. 2nd. In a steam boiler, the combination of a shell having a considerable inclination, a tubular fire box in the lower end of said shell completely surrounded by water, fire tubes in the rear or elevated end of said shell, a trunk at the upper rear end of said shell forming a steam dome or connection with a steam drum and a shield or baffle plate covering that part under the opening in said shell, through which the circulating current descends. 3rd. In a steam boiler, the combination of a shell having a considerable inclination, a tubular fire box in the forward and lower end of said shell, fire tubes between the rear end of said fire box and rear end of the shell, a steam reservoir such as a drum above the shell, a connecting trunk between said reservoir and shell placed upon the elevated portion of the latter, a circulating trunk or tube connecting the bottom of the reservoir with the shell, and a curved shield or baffle plate under the discharge end of said circulating trunk or tube within said shell and covering the internal part within said shell, above which said opening is located, substantially as set forth. 4th. In a steam boiler, the combination of a shell set at a considerable inclination, a tubular fire box in the lower part of said shell, fire tubes between the rear end of said fire box and rear end of said shell, a steam reservoir such as a drum above said shell, a connecting trunk between said reservoir and shell placed upon the elevated portion of the latter, a circulating trunk or tube connecting the bottom of the reservoir with the upper part of the crown of the shell, a shield or baffle plate under the opening of said circulating trunk, or tube within said shell and a casing surrounding said shell and part of the reservoir and forming flues at the sides, rear and

top, substantially as set forth. 5th. The combination with an inclined shell rising from front to rear, of an internal tubular fire box in the front or lower end of said shell, fire tubes between the rear end of said fire box and rear end of the shell, a longitudinal steam drum above said shell, a connecting trunk with said drum and shell at the elevated end of the latter, a circulating tube extending from the forward end of said drum to the crown of the shell at the forward end, a baffle plate under the discharge end of said tube within said shell partly surrounding the fire box, and a casing surrounding said shell and partly said drum provided with fire door and chimney stack trunk above the front, substantially as set forth.

**No. 57,401. Wire Stretcher. (Tendeur de fil de fer.)**

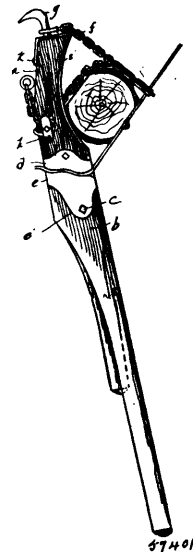

John E. Wheelock, Collinsville, Connecticut, U.S.A., 14th September, 1897; 6 years. (Filed 28th July, 1897.)

*Claim.*—1st. The two levers pivotally connected together, and equipped with the reversely-curved pinching irons shaped and adapted to hold the stretching iron in advanced of the body lever when a wire is grasped, all substantially as described and for the purpose set forth. 2nd. In combination, the body lever equipped with one of the reversely-curved pinching irons, the stretching lever also equipped with one of the reversely-curved pinching irons covering the end thereof and provided with ears extending along the sides thereof, and the pivot bolt traversing both of said ears, all substantially as described and for the purpose set forth. 3rd. In combination, the stretching lever, the body lever provided with the concave post-grasp, and the chain adapted for temporary attachment at two points of the body lever, all substantially as described and for the purpose set forth. 4th. In combination, the body lever provided with the concave post-grasp, the facing iron fitted to the post-grasp and the end of said lever, and to the back of the same, the staple hook entering the end of said lever through said facing iron, and the pin entering the back of said lever through said facing iron, all substantially as described and for the purpose set forth.

**No. 57,402. Motor Vehicle. (Véhicule à moteur.)**

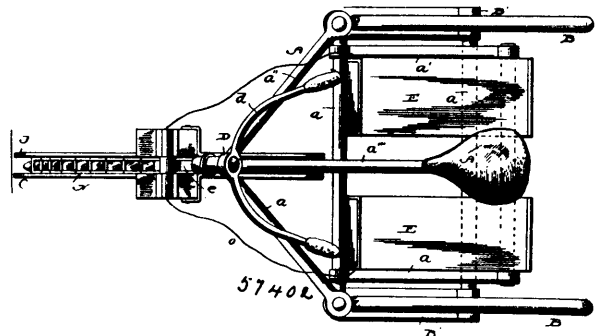

Charles Henry Barrows, Williamantic, Connecticut, U.S.A., 14th September, 1897; 6 years. (Filed 23rd July, 1897.)

*Claim.*—1st. In a motor vehicle, the combination with a steering spindle, and a steering and driving wheel carried by said spindle, of a rotary twin electric motor mounted on the spindle to have its

weight distributed equally on opposite sides thereof, and direct gear connections between the motor-shaft and said driving wheel, substantially as and for the purposes described. 2nd. In a motor vehicle, the combination with a steering spindle, of a front wheel having a driving rim within the divided thread of the wheel, a twin electric motor balanced on the steering spindle and having the driving pinion secured to its shaft between the divided field magnets and armature, and a chain or belt which connects said driving pinion and the driving rim directly together, substantially as and for the purposes described. 3rd. In a motor vehicle, the frame consisting of the steering head, the laterally diverging bars  $a^1$ ,  $a^{11}$  rear bars joined to the bars  $a^1$ ,  $a^{11}$ , in combination with a steering joined to said head and connected to each other, and the forked spindle carrying the front wheel, the rear wheels journalled in the forked rear bars, a rotary twin motor balanced on the steering spindle, and direct gear connections between the motor shaft and the front wheel, substantially as described. 4th. In a motor vehicle, the wheel C having the spaced rims and the propelling rim or wheel secured between said spaced rims and within the edges of the same, said propelling rim or wheel forming lateral clearance spaces between itself and the spaced rims, substantially as and for the purposes described.

**No. 57,403. Washing Machine. (Machine à laver.)**

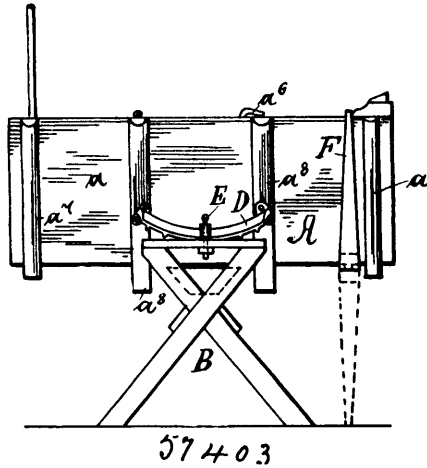

Frank Alderman, Fort Wayne, Indiana, U.S.A., 14th September, 1897; 6 years. (Filed 24th August, 1897.)

*Claim.*—A washing machine, comprising in its construction the standards B, having the stop-blocks M, and the channel-plates C, provided with transverse grooves  $c^1$ , and the box A, having side cleats  $a^1$ , projecting downward and adapted to abut against the ends of block M, and the rockers D, provided with ribs  $d^2$ , the engagements of the said ribs and grooves serving to prevent endwise jarring of the box when the cleats abut against the blocks M.

**No. 57,404. Stirrup. (Etrier.)**

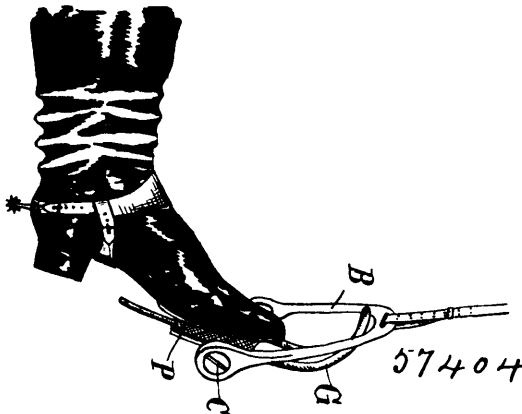

Carl Steenken, Dinghingen, Grand Duchy Baden, Germany, 14th September, 1897; 6 years. (Filed 24th August, 1897.)

*Claim.*—A safety stirrup, consisting essentially of a stirrup B, a foot supporting plate P, revolvably connected with B, and roughened on its upper surface, and having on its underside adjustably attached a forked front piece G, which in the event of a fall is impelled upwards in front through the pressure of the foot behind and by means of its aforesaid elevated front part thrusts the foot completely out of the stirrup.

**No. 57,405. Metallic Packing.**

(Garniture métallique.)

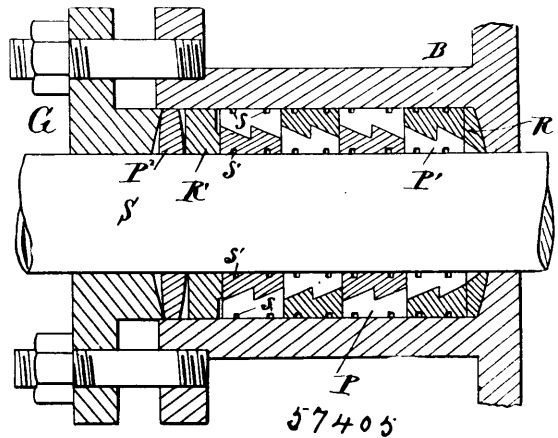

Joseph Thomas Naylor Angel, New York, State of New York, U.S.A., 14th September, 1897; 6 years. (Filed 24th August, 1897.)

*Claim.*—1st. A metallic packing, composed of an inner and an outer ring, each in section, the inner face of the first and the outer face of the second being adapted, as described, to fit respectively the shaft to be packed, and the stuffing box, and the contiguous faces of said inner and outer rings, being in the form of inclined planes, with their high points reversely set, all substantially as set forth. 2nd. A metallic packing, composed of an inner and an outer ring, each in section, the inner face of the first and the outer face of the second being adapted, as described, to fit respectively the shaft to be packed and the stuffing box, and the contiguous faces of the said inner and outer rings, being in the form of inclined planes with their high points reversely set, "each provided with water seal grooves," all substantially as set forth. 3rd. A metallic packing, composed of an inner and an outer ring, each in section, the inner face of the first and the outer face of the second being adapted as described to fit respectively the shaft to be packed and the stuffing box, and the contiguous faces of said inner and outer rings, each being in the form of two inclined planes with the high points of the inclined planes of one ring reversely set to the high points of the inclined planes of the other ring, all substantially as set forth. 4th. A metallic packing, composed of an inner and an outer ring, each in section, the inner face of the first and the outer face of the second being adapted, as described, to fit respectively the shaft to be packed and the stuffing box, and the contiguous faces of said inner and outer rings, each being in the form of two similar inclined planes, with the high points of the inclined planes of one ring, reversely set to the high points of the inclined planes of the other ring, all substantially as set forth. 5th. A metallic packing, composed of an inner and an outer ring, each in section, the inner face of the first and the outer face of the second being adapted, as described, to fit respectively the shaft to be packed and the stuffing box, and the contiguous faces of said inner and outer rings being in the form of inclined planes, with their high points reversely set and provided respectively with projections and recesses, all substantially as set forth. 6th. A metallic packing, composed of an inner and an outer ring, each in section, the inner face of the first and the outer face of the second being adapted, as described, to fit respectively the shaft to be packed and the stuffing box, and the contiguous faces of said inner and outer rings, being in the form of inclined plates, with their high points reversely set, the adjacent edges of the several sections of the inner ring being bevelled, all substantially as set forth. 7th. A metallic packing, composed of a series of compound rings substantially as set forth, the several rings of the series having notches and projections, all substantially as set forth. 8th. A stuffing box packing, composed of a series of compound rings, substantially as set forth, a ring adapted to be interposed between the bottom of the stuffing box and one member of the lower pair of rings and a second body adapted to be interposed between the other member of the upper pair of rings and the gland, all substantially as set forth.

**No. 57,406. Means for Supporting Rotating Shafts.**

(Support pour arbres rotatoires.)

William Stanley and Frederick Darlington, both of Pittsfield, Massachusetts, U.S.A., 14th September, 1897; 6 years. (Filed 13th August, 1897.)

*Claim.*—1st. The combination of a rotatable shaft of magnetic material, and a magnetic system producing a magnetic flux symmetrical thereto and in supporting relation thereto, substantially as described. 2nd. The combination of a rotatable shaft and bearings for the same, said shaft having a capacity of limited longitudinal movement, and means for producing a magnetic flux in suspending



relation to said shaft and symmetrical thereto, substantially as described. 3rd. The combination of a rotatable shaft, having pro-

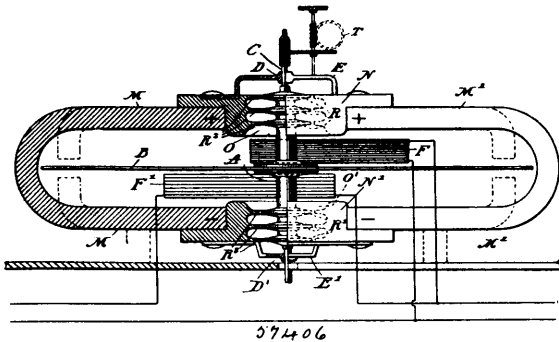

jecting rings of magnetic material concentric with its axis of revolution, and a magnetic system supplying a magnetic flux symmetrical with said rings, substantially as described. 4th. The combination of a rotatable shaft, and bearings for the same, permitting of longitudinal movement, and a permanent magnet supplying a magnetic flux symmetrical with said shaft, and acting upon said shaft in opposition to the force of gravity, substantially as described. 5th. The combination of a magnetic shaft, journaled in cylindrical bearings, and having projecting rings, of a permanent magnet having a consequent pole surrounding said shaft, and its projecting rings in suspending relation thereto, substantially as described. 6th. The combination of a magnetic shaft supported in suitable bearings, having two sets of projecting rings, and a magnetic system having a consequent pole, substantially in the plane of one set of rings, and a second consequent pole of opposite polarity, substantially in the plane of the other set of rings, substantially as described. 7th. In an electrical measuring device, a shaft carrying a rotating disc of conducting material, in combination with a supporting magnetic system, said system supplying a magnetic flux passing through said disc near its periphery, substantially as described.

**No. 57,407. Box or Package. (Boîte ou paquet.)**

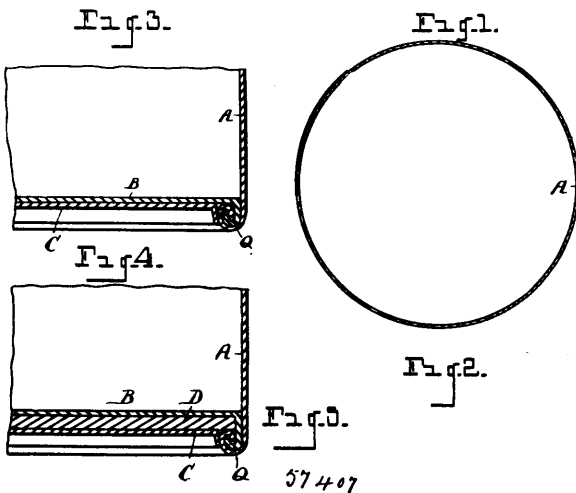

Harry M. Lick, Detroit, Michigan, U.S.A., 15th September, 1897; 6 years. (Filed 9th October, 1896.)

*Claim.*—1st. A box, having in combination an end-piece formed with a downwardly-projecting peripheral flange, a body having one of its extremities projecting downwardly about said end-piece and its flange, said flange and the adjacent extremity of said body rolled together to unite the body and end-piece, substantially as set forth. 2nd. A box, having in combination an end-piece formed with a peripheral flange, a body projecting around and about said end-piece and its flange, said flange and the adjacent extremity of said body rolled inward and adjacent to the outer surface of said end-piece to unite the body and end-piece, substantially as set forth. 3rd. A box, constructed of an end-piece having a peripheral flange, a body projecting about said end-piece and its flange, said flange and the adjacent extremity of the body rolled inward together to unite said end-piece and body, and forming an inwardly-turned peripheral rim, and in combination therewith a fastening piece secured to the outer surface of said end-piece, the peripheral edge of said fastening piece engaged snugly against the inner periphery of said rim, substantially as and for the purpose described. 4th. A box, having in combination an end-piece or head formed with a downwardly-projecting peripheral flange, and a body having one of

of its extremities projecting downwardly about the periphery of said end-piece and its flange, said flange and the adjacent extremity of said body inwardly rolled together to unite the body and end-piece, the extremity of the body being rolled over the adjacent edge of said flange, substantially as set forth. 5th. A box, having in combination an end-piece formed with a peripheral flange, a body projecting around and about the periphery of said end-piece and its flange, and a strengthening head D located against said end-piece, said flange and the adjacent extremity of said body inwardly rolled together to unite the body and end-piece, substantially as set forth. 6th. A box, constructed of an end-piece having a peripheral flange, a body projecting about said end-piece and its flange, a strengthening head D, and a fastening piece C, said flange and the adjacent extremity of the body rolled inward together to unite said end-piece and body, and forming an inwardly-turned peripheral rim, the peripheral edge of said fastening piece engaged snugly against the inner periphery of said rim, substantially as and for the purpose described.

**No. 57,408. Barrel Machine. (Machine à baril.)**

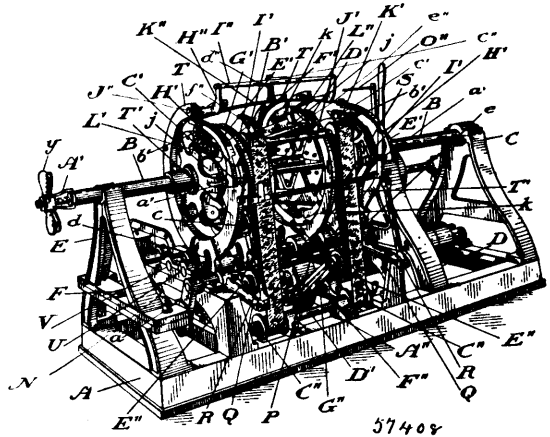

Alexander Buntin, assignee of William Thomas, both of Toronto, Ontario Canada, 15th September, 1897; 6 years. (Filed 28th October, 1896.)

*Claim.*—1st. The combination in a barrel machine and with the former thereof, of two shafts U and V, suitably journaled on the frame of the machine, two or more sets of sweeps or half rings T, T<sup>1</sup>, the front sweep being mounted on the rear shaft and the rear sweep being mounted on the front shaft, the said sweeps and shaft being shaped to avoid each other when the sweeps are dropped to release the barrel, pinions secured to said shafts U and V, thereby gearing them together, and means for operating said shaft, substantially as and for the purpose specified. 2nd. In a barrel machine and in combination with the former thereof, of two shafts U and V, pinions e and f secured to said shafts and thereby gearing the latter together, front and rear sweeps, the front sweep being connected to the rear shaft and the rear sweep to the front shaft, said sweeps being slotted a c and d to allow of the sweeps moving without interference with said shafts U and V, means as the handle G, for opening and closing said shafts, and a weighted arm k, connected with one of said shafts and arranged to normally hold the sweeps in a closed position, substantially as described. 3rd. In a barrel machine, mechanism for feeding staves into the barrel forming portion of the machine, comprising the following elements:—the upper portions G<sup>1</sup>, of the outer sweeps T<sup>1</sup>, the guides B<sup>1</sup>, formed on or connected thereto, the stave carrier S, adapted to slide thereon, means for reciprocating the stave carrier on the said guides, the stave guides E<sup>1</sup>, having flanges F<sup>1</sup>, formed thereon and cut-away at H<sup>1</sup>, substantially as and for the purpose specified. 4th. In a barrel machine, mechanism for feeding staves into the barrel-forming portion of the machine comprising the following elements:—the upper portions G<sup>1</sup>, of the outer sweeps T<sup>1</sup>, the guides B<sup>1</sup>, formed on or connected thereto, the stave carrier S, adapted to slide thereon, fingers D<sup>1</sup>, formed on or connected to the stave carrier, means for reciprocating the stave carrier on the said guides, and the stave guides E<sup>1</sup>, having flanges F<sup>1</sup>, formed thereon and cut-away at H<sup>1</sup>, substantially as and for the purpose specified. 5th. In a barrel machine, mechanism for preparing the end or ends of the stave comprising the following elements:—the upper portions G<sup>1</sup>, of the outer sweeps T<sup>1</sup>, the outer sweeps T<sup>1</sup>, the cutter-shaft J<sup>1</sup>, journaled in one or both, means for rotating the same, one or more cutter-heads L<sup>1</sup>, on the said shaft, stave guides E<sup>1</sup>, the flanges F<sup>1</sup> thereon, and means for feeding the staves past the cutter-head or heads, substantially as and for the purpose specified. 6th. In a barrel machine, mechanism for preparing the ends of the staves comprising the following elements:—the upper portions G<sup>1</sup>, of the outer sweeps T<sup>1</sup>, the cutter-shaft J<sup>1</sup> journaled therein, means for rotating the same, the cutter-heads L<sup>1</sup>, secured on the said shaft and carrying hollowing, crozing and

chamfering tools and the equalizing saws P<sup>1</sup>, the stave guides E<sup>1</sup>, the flanges F<sup>1</sup> formed thereon and having slots R<sup>1</sup>, formed therein through which the equalizing saws P<sup>1</sup> pass, and means for feeding the staves past the cutter-heads, substantially as and for the purpose specified. 7th. In a barrel machine, mechanism for preparing the ends of the staves comprising the following elements:—the upper portions G<sup>1</sup>, of the outer sweeps T<sup>1</sup>, the cutter-shaft J<sup>1</sup>, journaled therein, means for rotating the same, the cutter-heads L<sup>1</sup> on the said shaft, the stave guides E<sup>1</sup>, the flanges F<sup>1</sup> thereon, the springs I<sup>1</sup> secured to the upper portions G<sup>1</sup> of the outer sweeps T<sup>1</sup> and adapted to press the stave ends against the stave guides E<sup>1</sup>, and means for feeding the staves past the cutter-heads, substantially as and for the purpose specified. 8th. In a barrel machine, mechanism for preparing the ends of the staves comprising the following elements:—the upper portions G<sup>1</sup> of the outer sweeps T<sup>1</sup>, the cutter-shafts J<sup>1</sup> journaled therein, means for rotating the same, the cutter-heads L<sup>1</sup> on the said shaft, the stave guides E<sup>1</sup>, the flanges F<sup>1</sup> thereon, the springs I<sup>1</sup> secured to the upper portions G<sup>1</sup> of the outer sweeps T<sup>1</sup>, and adapted to press the stave ends against the stave guides E<sup>1</sup>, guides B<sup>1</sup> on the said portions G<sup>1</sup>, heads C<sup>1</sup> sliding thereon, the stave carrier S, connected thereto and means for reciprocating the stave carrier, substantially as and for the purpose specified. 9th. In a barrel machine, mechanism for preparing the ends of the staves comprising the following elements:—the upper portions G<sup>1</sup> of the outer sweeps T<sup>1</sup>, the cutter-shaft J<sup>1</sup>, journaled therein, means for rotating the same, the cutter-heads L<sup>1</sup> on the said shaft, the stave guides E<sup>1</sup>, the flanges F<sup>1</sup> thereon, the springs I<sup>1</sup>, secured to the upper portions G<sup>1</sup> of the outer sweeps T<sup>1</sup>, and adapted to press the stave ends against the stave guides E<sup>1</sup>, guides B<sup>1</sup> on the said portions G<sup>1</sup>, heads C<sup>1</sup> sliding thereon, the stave carrier S, connected thereto, the fingers D<sup>1</sup> on the stave carrier, and means for reciprocating the stave carrier, substantially as and for the purpose specified. 10th. In a barrel machine, a former carried by a former shaft, in combination with a stationary standard or standards forming a bearing for one end of the shaft and a divided standard forming a bearing for the other end of the shaft, the halves of the standard being pivoted so that they may be swung aside to leave the way clear for the removal of a barrel from the former, substantially as and for the purpose specified. 11th. In a barrel machine, the combination of a former and a former shaft B, journaled in the standards C and D and the dividend standard E, the halves of which are pivoted at a and notched at b to fit against a pin F, substantially as and for the purpose specified. 12th. In a barrel machine, the combination of a former and a former shaft B, journaled in the standards C and D, and the standard E, the halves of which are pivoted at a and notched at b, a headed pin F, arranged to co-act with the notched halves of said standard, substantially as and for the purpose specified. 13th. In a barrel machine, a stave feeder comprising the following elements:—the curved bars g<sup>11</sup>, stave h<sup>11</sup>, cross-bar i<sup>11</sup>, and one or more sets of lugs k<sup>11</sup> connected to the curved bars g<sup>11</sup>, substantially as and for the purpose specified. 14th. In a barrel machine, trussing mechanism comprising two blocks, right and left hand-threaded spindles passing through similarly-threaded holes in said blocks, means for rotating said spindles to move said blocks to and from each other, a ring having its ends pivotally connected to said blocks, and means, as the pin b<sup>3</sup>, for allowing a rapid detachment of the ring, substantially as described. 15th. In a barrel machine, trussing mechanism comprising the following elements:—the half rings a<sup>111</sup> pivoted together at b<sup>111</sup>, the blocks g<sup>111</sup> and h<sup>111</sup> to which the half rings a<sup>111</sup> are pivoted at c<sup>111</sup> and f<sup>111</sup>, one of the blocks being adapted to slide upon the shafts U and V supporting the block g<sup>111</sup>, right and left-hand screw-threaded spindles i<sup>111</sup> fitting correspondingly-threaded holes in the blocks g<sup>111</sup> and h<sup>111</sup>, and means for operating the spindles, substantially as and for the purpose specified.

#### No. 57,409. Change-Giving Money Till.

(Caisse de comptoir.)

The Harper Trading Syndicate, Limited, Cheapside, London assignee of Frederic Oldershaw Jerram and Arther Ernest Jerram, both of Tooting, Surrey, all in England, 15th September, 1897; 6 years. (Filed 28th April, 1897.)

*Claim.*—1st. In a change-giving money till, the combination of a series of coin tubes, a series of slides for controlling the discharge of coins from said tubes, perforated segments or plates adapted to control the movement of said slides, and debit and credit levers or handles for actuating said segments or plates as and for the purpose set forth. 2nd. In a change-giving money till, a pair of segments or plates, means controlled by each segment whereby coins are delivered from said till, and an operative connection between one segment and the parts operating in connection with the other segment as and for the purpose set forth. 3rd. In a change-giving money till, the combination of a series of adjustable sections formed with coin conveying portions, a series of coin containing tubes located above said coin conveying portions, a series of pusher rods adapted to adjust said sections, and one or more adjustable devices adapted to be interposed between certain of said sections and their pusher rods, and means for adjusting said devices, as and for the purpose set forth. 4th. In a change-giving money till, the combination of a series of adjustable sections formed with coin conveying

portions, a series of coin containing tubes located above said coin conveying portions, a series of pusher rods adapted to adjust said

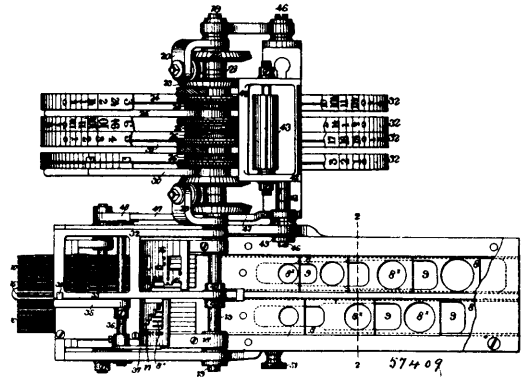

sections, a pair of segments having openings therethrough adapted to register with certain of said pusher rods, and means for operating said segments, substantially as and for the purpose set forth.

#### No. 57,410. Fertilizer Distributer.

(Distributeur d'engrais.)

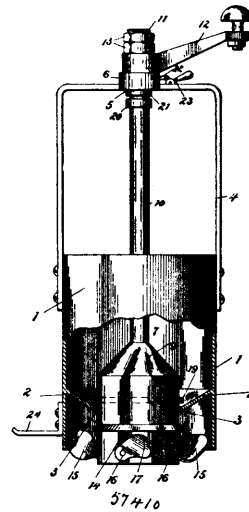

Louis Victor Labelle, St. Jacques l'Archevêque, Quebec, Canada, 15th September, 1897; 6 years. (Filed 28th August, 1897.)

*Claim.*—1st. In a fertilizer distributor, the combination with a casing or hopper, of a mixer located therein, and means carried by said mixer for pulverizing the soil, substantially as set forth. 2nd. In a fertilizer distributor, the combination with a casing or hopper, of a mixer rotatably mounted therein, and means carried by said mixer for pulverizing the soil, substantially as set forth. 3rd. In a fertilizer distributor, the combination with a casing or hopper, of a spindle arranged therein, a series of pulverizing blades carried by said spindle, and a series of mixing blades also carried thereby, substantially as set forth. 4th. In a fertilizer distributor, the combination with a casing or hopper, of a spindle arranged therein, a series of pulverizing blades carried by said spindle, and a series of mixing blades also carried thereby, said mixing blades being reversely inclined to the pulverizing blades, substantially as set forth. 5th. In a fertilizer distributor, the combination with a casing or hopper, of a spindle arranged therein, a series of pulverizing blades carried by said spindle, and a series of mixing blades also carried thereby, said mixing blades alternating with the pulverizing blades and being reversely inclined thereto, substantially as set forth. 6th. In a fertilizer distributor, the combination with a casing or hopper, of a spindle arranged therein, a protecting drum or casing also arranged in said casing and connected to said spindle, and means carried by said drum for pulverizing the soil, substantially as set forth. 7th. In a fertilizer distributor, the combination with a casing or hopper, of a spindle arranged therein, a protecting drum or casing also arranged in said casing and connected to said spindle, means carried by said drum for pulverizing the soil, and means also carried by said drum for fixing the fertilizer with the soil, substantially as set forth. 8th. In a fertilizer distributor, the combi-

nation with a casing or hopper provided with an opening through which the fertilizer is adapted to pass, of a mixer disposed in said casing or hopper and arranged in said opening, and means carried by said mixer for closing said opening, substantially as set forth. 9th. In a fertilizer distributor, the combination with a casing or hopper provided with an opening through which the fertilizer is adapted to pass, of a mixer disposed in said casing or hopper and arranged in said opening, means carried by said mixer for closing said opening, and means for locking the mixer to retain said closing means in said opening, substantially as set forth. 10th. In a fertilizer distributor, the combination with a casing or hopper provided with an opening through which the fertilizer is adapted to pass, of a spindle arranged therein, a protecting drum or casing also arranged in said casing and disposed in the opening thereof, said protecting drum or casing being connected to said spindle, means carried by the protecting drum for pulverizing the soil, means also carried by said protecting drum for mixing the soil, means for closing the opening of the casing or hopper, and means for locking said closing means in said opening, substantially as set forth. 11th. In a fertilizer distributor, the combination with a casing or hopper provided with an opening through which the fertilizer is adapted to pass, of a spindle arranged therein, a protecting drum or casing also arranged in said casing and disposed in the opening thereof, said protection drum or casing being connected to said spindle, a series of blades carried by the protecting drum for pulverizing the soil, a series of blades also carried by said protecting drum for mixing the soil, means for closing the opening of the casing or hopper, and means for locking said closing means in said opening, substantially as set forth. 12th. In a fertilizer distributor, the combination with a casing or hopper provided with an opening through which the fertilizer is adapted to pass, of a spindle arranged therein, a protecting drum or casing also arranged in said casing and disposed in the opening thereof, said protecting drum or casing being connected to said spindle, means carried by the protecting drum for pulverizing the soil, means also carried by said protecting drum for mixing the soil, a cut-off mounted upon the protecting drum and adapted to close the opening of the casing or hopper, and a pin adapted to engage the spindle for locking said cut-off in said opening, substantially as set forth. 13th. In a fertilizer distributor, the combination with a casing or hopper provided with an opening through which the fertilizer is adapted to pass, of a spindle arranged therein, a protecting drum or casing also arranged in said casing and disposed in the opening thereof, said protecting drum or casing being connected to said spindle, a series of blades carried by the protecting drum for pulverizing the soil, a series of blades also carried by said protecting drum for mixing the soil, a cut-off mounted upon the protecting drum and adapted to close the opening of the casing or hopper, and a pin adapted to engage the spindle for locking said cut-off in said opening, substantially as set forth. 14th. In a fertilizer distributor, the combination with a casing or hopper, of a mixer rotatably mounted therein, a crank adjustably mounted on said mixer for operating the same, and means for locking the crank in its adjusted position, substantially as set forth. 15th. In a fertilizer distributor, the combination with a casing or hopper, of a mixer rotatably mounted therein and comprising a protecting drum or casing, a spindle connected thereto, a series of blades for pulverizing the ground, a series of blades for mixing the fertilizer therewith, and a spring disposed in said protecting drum or casing for forcing the fertilizer from the casing or hopper, a crank adjustably mounted on the spindle, and a series of jamb-nuts for locking the crank in its adjusted position, substantially as set forth. 16th. In a fertilizer distributor, the combination with a casing or hopper provided with a bottom having its sides inclining downwardly and converging towards the centre to form a feed opening, of a mixer arranged in said casing or hopper and working in said opening, said mixer comprising a protecting drum or casing having its lower end open, a spindle connected to its upper end and projecting upwardly therefrom, said spindle having its upper end screw-threaded, a series of curved pulverizing blades carried by said protecting drum and arranged diametrically opposite, a series of curved mixing blades also carried by said protecting drum and also arranged diametrically opposite, said mixing blades alternating with the pulverizing blades and being reversely inclined thereto, a cut-off mounted upon the protecting drum and adapted to close the feed opening of the casing or hopper, and a spring arranged in the protecting drum and provided at its ends with scraping spurs, said spurs passing through the sides of said drum and extending into the casing or hopper above the bottom thereof, an upwardly-extending yoke carried by said casing or hopper, the upper end of said spindle passing through said yoke, a crank adjustably mounted on the threaded end of said spindle, a series of jamb-nuts also carried by said threaded end for retaining the crank in its adjusted position, a peripherally-grooved collar fixed upon said spindle, and a locking pin mounted on said yoke and adapted to engage the grooved collar, substantially as and for the purpose set forth.

**No. 57,411. Bottle and Similar Receptacle and Stopper. (Bouteille et bouchon.)**

Ephraim A. Foster, Port Clinton, Ohio, U.S.A., 15th September, 1897; 6 years. (Filed 23rd August, 1897.)

*Claim.*—The combination with a frangible bottle, the neck having a solid head formed with a recess at the junction of said head

and with a slot communicating with said recess having shoulders at the upper and lower sides, of the stopper consisting of a spring

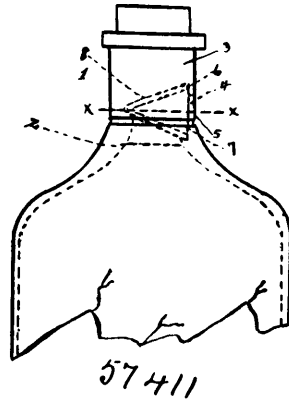

metal plate bent over at the centre forced into said recess, and its ends engaging with said shoulders, substantially as described.

**No. 57,412. Self-Closing Faucet. (Robinet automatique.)**

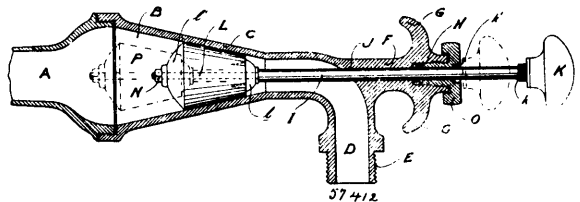

Agenor Ferland, Ste. Marie, Quebec, Canada, 15th September, 1897; 6 years. (Filed 23rd August, 1897.)

*Claim.*—A compression faucet having a valve formed by means of a rubber plug secured to an operating rod having a knob on its outward end, this rubber plug working in a conical cavity, means for preventing leakage along the operating rod, means for keeping the valve open, and projections for inserting the fingers to open the valve, all substantially as described, and for the purposes set forth.

**No. 57,413. Tank-Heater. (Chauffeur de citerne.)**

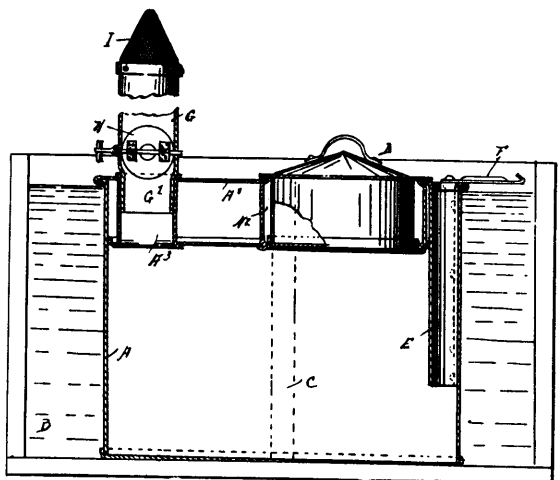

Andrew W. Johnson, Peter T. Herried and Thomas Herried, all of Blair, Wisconsin, U.S.A., 15th September, 1897; 6 years. (Filed 27th August, 1897.)

*Claim.*—1st. A tank-heater, comprising a casing adapted to be fastened in a tank containing the liquid, feed or the like to be heated, said casing being provided with a combustion chamber, and having a double top forming a closed air-space for the purpose of preventing radiation of heat, substantially as shown and described. 2nd. A tank-heater, comprising a casing adapted to be set in a tank containing the liquid, feed or the like to be heated, said casing provided with a double top, forming a combustion chamber in the lower portion of the casing, a draft-channel in one end of said casing,

and a chimney held on the other end of said casing, and set in a thimble secured in said double top, substantially as shown and described. 3rd. A tank-heater, provided with a casing, adapted to be set in the tank containing the liquid, feed or the like to be heated, said casing being provided with a double-top and a combustion chamber in the lower portion of said casing, said double top being provided with a manhole and a cover fitting said manhole and seated thereon at its lower and upper ends, substantially as shown and described.

**No. 57,414. Hand Corn Planter.**

(*Planteur de blé d'inde.*)

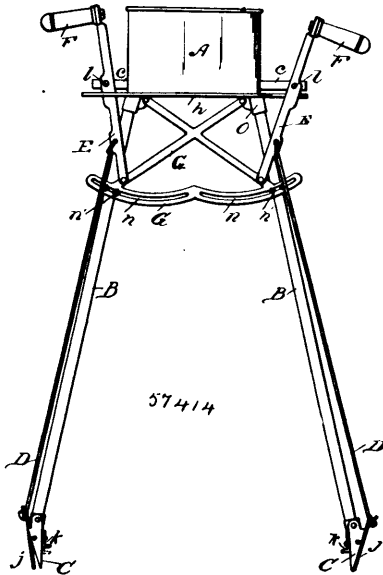

Thomas S. Fair, Detroit, Michigan, U.S.A., 15th September, 1897; 6 years. (Filed 30th June, 1897.)

*Claim.*—1st. In a hand planter the combination of the feed hopper, conducting tubes leading therefrom, adjustable points engaged to said tubes, means whereby seed may be permitted to pass from the hopper to the point of discharge when desired, and means for operating the planting points whereby the seed may be planted, substantially as described. 2nd. In a hand planter, the combination of a hopper, conducting tubes, planting points and feed bars, substantially as described. 3rd. A hand planter having a hopper conducting tubes therefrom, hubs attached to said tubes, and planting points with means for engaging said hub substantially as described. 4th. A hand planter having a hopper, conducting tubes therefrom, means for adjusting the same to rows of different distances apart, hubs attached to said tubes, and adjustable planting points, substantially as described.

**No. 57,415. Harrow. (Herse.)**

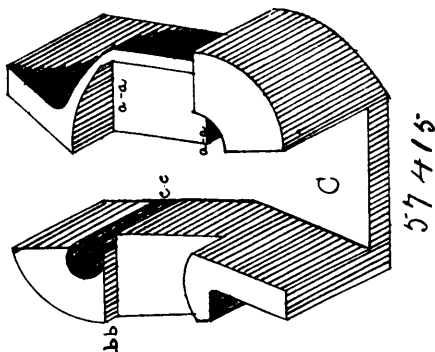

Richard Myers and James Y. Bambridge & Co., all of Souris, Manitoba, Canada, 15th September, 1897; 6 years. (Filed 20th July, 1897.)

*Claim.*—1st. The tooth socket C, admitting of the adjustment of the tooth B, substantially as and for the purposes hereinbefore set forth. 2nd. The combination of the tooth socket C, admitting of adjustment of the tooth B, the frame A, and the tooth B, substantially as and for the purpose hereinbefore set forth.

**No. 57,416. Gas Meter. (Compteur à gaz.)**

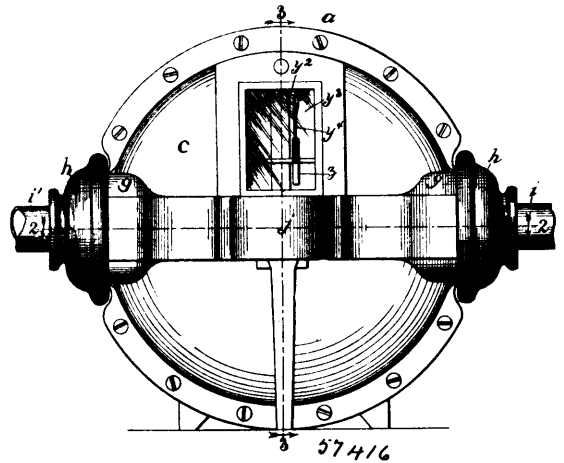

The International Meter Company, Chicago, assignee of Roswell H. Buckingham, Evanston, both of Illinois, U.S.A., 15th September, 1897; 6 years. (Filed 7th August, 1897.)

*Claim.*—1st. The combination with a valve-rod and diaphragm of a gas-meter, of a reciprocatory locking-bar in operative connection with a diaphragm, springs thereon in operative proximity to a valve-rod having its axis at right angles to that of the locking-bar, means upon said valve-rod for alternately compressing one or the other of said springs, a shoulder on said valve-rod for engaging said locking-bar and holding said valve-rod stationary while the locking-bar is being moved in a given direction, and openings in said locking-bar to permit the passage of said shoulder when one or the other of said openings is brought into registration therewith, substantially as described. 2nd. In a valve-controlling mechanism for gas-meters, the combination with a movable diaphragm of a locking-bar having one end attached to said diaphragm and arranged to move longitudinally between suitable guides, a reciprocatory valve-rod arranged at right angles to said bar, valves upon said bar adapted to alternately open and close induction and eduction ports communicating with the opposite sides of the diaphragm, a shoulder or projection upon said valve-rod adapted to engage with said locking-bar, openings in said bar at points corresponding to its extreme opposite movement to permit the passage of said shoulder when said extreme movement is reached in either direction, springs attached to opposite sides of said locking-bar, and studs attached to the valve-rod upon opposite sides of said bar in position to be engaged by or disengaged from said springs as said bar is reciprocated, substantially as described. 3rd. In a valve-controlling mechanism for gas meters, the combination with a movable diaphragm of a reciprocatory locking-bar arranged in guides, a reciprocatory valve-rod arranged at right angles thereto and provided with valves upon its ends adapted to control the admission of gas to induction and eduction ports communicating with the opposite sides of the diaphragm, springs attached to said bar for reversing the movement of said valve-rod, studs upon said valve-rod for alternately engaging one or the other of said springs, a shoulder or projection upon said valve-rod for engaging said locking-bar and locking said valve-rod in an extreme position pending the movement of the diaphragm, and openings or notches in said bar in alignment with said projection to permit the passage of the latter therethrough when the extreme movement of the diaphragm is reached, substantially as described. 4th. In a gas meter, the combination of a reciprocatory valve-rod having valves thereon for controlling the admission of gas to induction and eduction ports communicating with the opposite sides of the diaphragm, of a reciprocatory locking-bar arranged at right angles to the axis of said valve-rod springs upon opposite sides of said bar for alternately reciprocating said valve-rod, means upon said valve-rod for engaging said springs, a shoulder upon said valve-rod for engaging said bar and locking said rod in an extreme position pending the movement of said diaphragm, and notches or openings in said bar having oppositely inclined wedge-shaped faces for engaging said shoulder, supplementing the spring action, and forcing said valves firmly upon their seats pending the movement of said diaphragm, substantially as described. 5th. The combination with a valve-rod and diaphragm of a gas meter, of a reciprocatory locking-bar in operative connection with the diaphragm, springs thereon in operative proximity to a valve-rod, a valve-rod having its axis at right angles to that of the locking-bar, means upon said valve-rod for alternately compressing one or the other of the said springs, a shoulder on said valve-rod for engaging said locking-bar and holding said valve-rod stationary against the actions of one of said springs, while the locking-bar is completing its movement in a given direction, said shoulder being bevelled upon opposite sides whereby it may be caused to wedge against said locking-bar, and openings or notches in said locking-bar to permit the passage of said shoulder, substantially as described. 6th. In a gas-meter, a casing composed of two parts, a flexible or movable dia-

phragm interposed and clamped between the two, induction and eduction valve ports respectively communicating with the chamber formed between the diaphragm and each of said parts, valve-rods located upon opposite sides of said diaphragm and parallel with the plane thereof, valves thereon for opening and closing said ports, and means for actuating said rods simultaneously and in opposite directions, substantially as described. 7th. In a gas meter, a casing composed of two parts, a movable diaphragm interposed between said parts so as to form separate independent compartments, induction and eduction valve ports respectively located diametrically opposite to each other upon the edge of said casing adjacent to said diaphragm communicating with each of said compartments, parallel valve-rods located upon opposite sides of said diaphragm, valves thereon for opening and closing said ports, a pivoted lever for connecting said valve-rods, and means in operative connection with the diaphragm for reciprocating said valve-rods in simultaneously opposite directions with each movement of the diaphragm, substantially as described. 8th. In a gas meter, a casing provided with two compartments, separated by means of an intervening movable diaphragm, induction and eduction valve-ports communicating with each of said compartments, a valve-rod in each of said compartments having valves thereon for opening and closing said respective ports, means for connecting said rods whereby the movement of one may cause them both to be reciprocated simultaneously in opposite directions, a reciprocating locking-bar in operative connection with said diaphragm and arranged to reciprocate in guides at right angles to the axis of said valve-rods, springs attached to said locking-bar for causing the reversal of said valve-rods, means upon one of said valve-rods for alternately engaging one or the other of said springs, a shoulder upon said last named valve-rod for engaging and locking said rod pending the movement of the diaphragm and openings or notches in said bar in alignment with said projection,—the distance of said openings from each other corresponding with the length of movement of the diaphragm, substantially as described. 9th. A gas meter having a case composed of two valves, a diaphragm clamped between said valves, cylindrical extensions located diametrically opposite to each other upon the edges or periphery of said casing, partitions therein, at or near the ends, provided with induction and eduction ports upon opposite sides of the diaphragm, removable caps or unions for the reception of induction and eduction service pipes, parallel valve-rods located upon opposite sides of the diaphragm and having valves therein in operative proximity to said parts respectively, means for connecting said valve-rods whereby they may be caused to move simultaneously in opposite directions when one is reciprocated and valve controlling mechanism in operative connection with said diaphragm, and with one of said valve-rods, substantially as described. 10th. The combination with a valve-rod and diaphragm of a gas meter, of a reciprocatory locking-bar in operative connection with the diaphragm, springs thereon in operative proximity to a valve-rod having its axis at right angles to that of the locking-bar, means upon said valve-rod for alternately compressing one or the other of said springs, a shoulder on said valve-rod for engaging said locking bar and holding said valve-rod stationary while the locking-bar is being moved in a given direction, openings in said bar to admit the transverse passage of said shoulder, and means for producing a wedge-like action between the locking-bar and shoulder when the valve-rod is shifted, substantially as specified.

**No. 57,417. Axle Box Bearing. (Cousinet d'essieu.)**

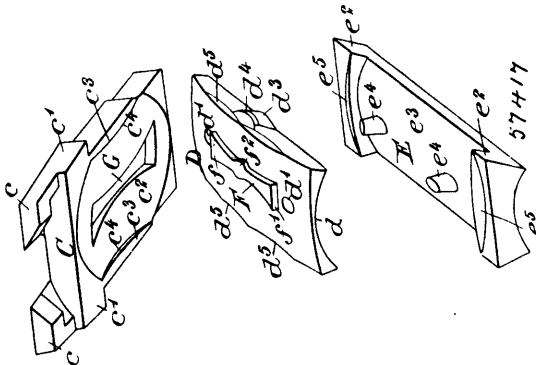

The Smith Adjustable Car Axle Bearing Co., Jersey City, New Jersey, assignee of William Benjamin Smith, New York, State of New York, both in the U.S.A., 15th September, 1897; 6 years. (Filed 20th April, 1897.)

*Claim.*—1st. The combination with the bearing sections, the one provided with a convex surface and the other with a concave surface adapted to conform to and seat upon the said convex surface of the other, of a safety stop fixed to one of the sections, and an abutment on the other section for engaging the stop to prevent the displacement of the said sections, in longitudinal direction of the axle as well as in the transverse direction, substantially as set forth. 2nd. The combination with the bearing sections, the one provided with a

convex surface and the other with a concave surface adapted to conform to and seat upon the said convex surface of the other, of a safety stop fixed to and uprising from the convex surface of one of the sections, the other of said bearing sections being provided with a recess in its concave surface to receive the stop on the other section, substantially as set forth. 3rd. The combination with the bearing sections, the one provided with a convex surface and the other with a concave surface adapted to conform to and seat upon the said convex surface of the other, of a safety stop uprising from the convex surface of the bearing section, said stop being elongated and gradually narrowed in width from its opposite ends toward its central portion, the other of said bearing sections being provided with a correspondingly shaped recess in its curved face for the reception of said stop, substantially as set forth.

**No. 57,418. Neck Yoke. (Volée d'avant.)**

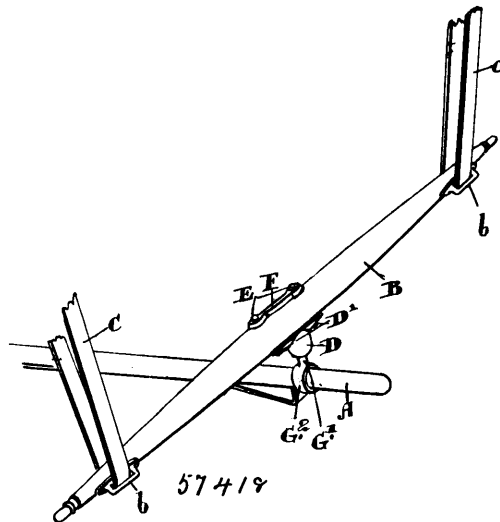

George Arthur Landon, Toronto, Ontario, Canada, 15th September, 1897; 6 years. (Filed 20th July, 1897.)

*Claim.*—1st. In combination the neck yoke, and pole, and a centre having a ball and socket connection between the neck yoke and pole as and for the purposes specified. 2nd. In combination the neck yoke, the ball socket with flanges and means for securing such flanges to the neck yoke, the ball with stem and oblique ring, and the pole extending through the obliquely shaped ring as and for the purpose specified. 3rd. In combination the neck yoke, the ball socket with flanges and means for securing such flanges to the neck yoke, the ball with the stem and oblique ring, and the pole extending through the obliquely shaped ring and rear slot in the socket attached to the neck yoke as and for the purpose specified.

**No. 57,419. Spring Bed Bottom. (Sommier élastique.)**

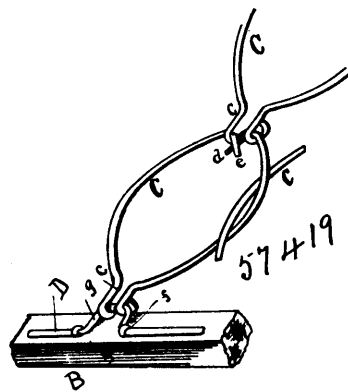

Thomas B. Casselberry, Williamsport, Pennsylvania, U.S.A., 15th September, 1897; 6 years. (Filed 23rd August, 1897.)

*Claim.*—A bed-spring formed from a single piece that is bent into a loop or circle, and which is provided at one end with a double hook c, having a space between the two prongs, and having its outer end turned downward at an acute angle, and at its other end with the two downward-turned free ends d, c, which are adapted to catch in the double hook of the next adjoining spring, substantially as shown.

**No. 57,420. Water Supply Apparatus.**  
(Appareil à approvisionner l'eau.)

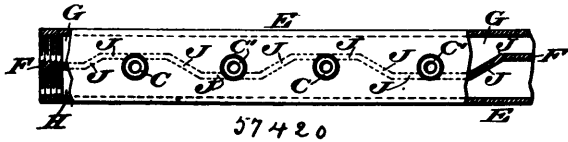

George Washington Conderman, Philadelphia, Pennsylvania, U.S.A., 15th September, 1897; 6 years. (Filed 23rd August, 1897.)

*Claim.*—1st. In a hot and cold water supply, a pipe having a longitudinal partition therein, forming two compartments extending the length thereof, each of said compartments having a series of openings therein and the partition being so deflected at intervals, in opposite directions whereby the openings of both series are in the same straight line. 2nd. As a new article of manufacture, a tube having a longitudinal partition therein forming two separate passages, said partition being formed with deflections at intervals in opposite directions, and said separated passages having outlets in the walls thereof, in the same right line. 3rd. A hot and cold water supply, consisting of a pipe having a longitudinal partition forming two compartments, each of said compartments having a series of openings therein, and the partition being deflected at intervals in opposite directions, whereby the openings of both series are in the same straight line, in combination with a tub or tray having openings in its back, corresponding with those of the pipe.

**No. 57,421. Rein-holder.** (Porte-réne.)

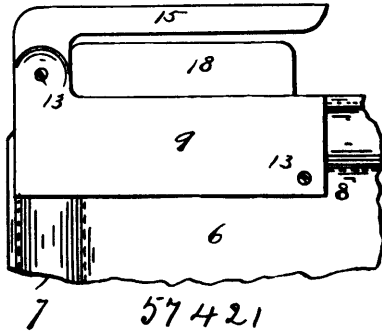

Beverly Edward Mead, Greenwich, Connecticut, U.S.A., 15th September, 1897; 7 years. (Filed 23rd August, 1897.)

*Claim.*—In a rein-holder having a head comprising two separate plates, each being provided centrally with a groove therein, an upwardly directed extension secured to one of said plates, an arm formed on the upper end of said extension and extending horizontally therefrom, a shoulder also secured near either end of the said latter plate, a shaft journaled therebetween, a jaw mounted on said shaft, and adapted to engage said arm, and a spiral spring also mounted on said shaft and engaging said jaw, all of the said parts being combined, substantially as described.

**No. 57,422. Vehicle Hub.** (Moyeu de roue.)

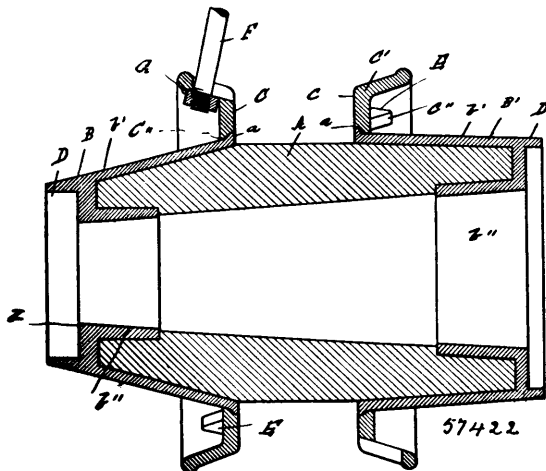

John Bell, Toronto, Ontario, Canada, 15th September, 1897; 6 years. (Filed 23rd August, 1897.)

*Claim.*—1st. A vehicle hub consisting of a sleeve, a cap fitted on each end of the sleeve consisting of a disc, and an outer flange overlapping the perimeter of the sleeve and an inner flange overlapping the bore of the sleeve, forming a portion of the boxing of the hub, and spoke flanges fitted on the caps, substantially specified. 2nd. A vehicle hub consisting of a sleeve, a cap fitted on each end of the sleeve consisting of a disc, an outer flange overlapping the perimeter of the sleeve, an inner flange overlapping the bore of the sleeve, forming a portion of the boxing of the hub, spoke flanges fitted on the caps, spoke sockets formed in the spoke flanges, spokes extending through the spoke sockets and nuts fitted on the spokes on the inner side of the spoke flanges, substantially specified.

**No. 57,423. Baking Oven.** (Four à cuire.)

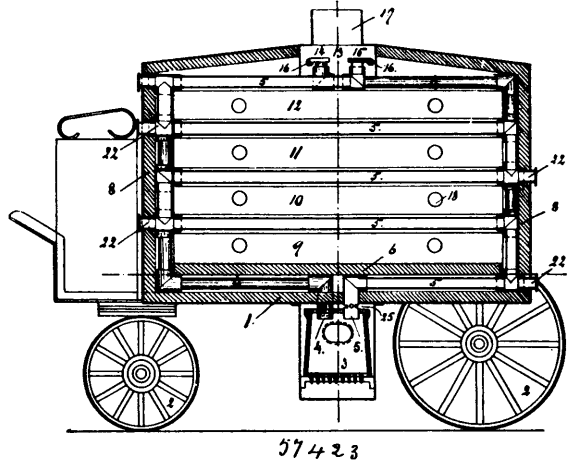

Ellen Mathilda Sjöholm, Stockholm, Sweden, 15th September, 1897; 6 years. (Filed 27th August, 1897.)

*Claim.*—1st. In a baking oven or the like, two rows of flue tubes running from the fire-place in zigzag upwards and alternating with each other so as to divide the oven into a number of baking chambers, substantially as and for the purpose set forth. 2nd. In a baking oven or the like, two rows of flue tubes running from a fire-place in zigzag upwards, alternating with each other, so as to divide the oven into a number of baking chambers, each row ending in an exhaust room and the tubes in each row provided with a lid, substantially as and for the purpose set forth. 3rd. In a baking oven or the like, two rows of flue-tubes running from a fire place, one row running horizontally to the left inside the bottom of the oven to the end of the same, whereupon it runs vertically a short distance inside the oven, then turning and running horizontally backwards to the opposite well where it again turns upward and backward and so on to the top of the oven where it runs out of the same, the other row running in the same way but in alternate directions, the horizontal parts of the two rows alternating with each other in the same plane, so as to divide the oven into a number of baking chambers, said horizontal parts being provided with soot-holes and plugs for the same, substantially as and for the purpose set forth.

**No. 57,424. Burners for Plumbers' and Braziers' Furnaces.** (Brûleur pour fournaies de plombiers, etc.)

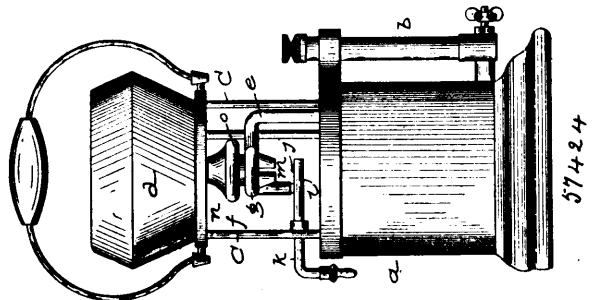

John Curtis Dupee, Chicago, Illinois, U.S.A., 15th September, 1897; 6 years. (Filed 23rd August, 1897.)

*Claim.*—1st. The combination with an oil reservoir and means for forcing a jet of oil therefrom under pressure, of a retort, means for projecting a vaporized jet from said retort through an opening extending through said retort into a combustion chamber, and a combustion chamber adjacent to said retort, said combustion chamber having a restricted opening at its outer end, an enlarge-



ment in the body thereof next to said retort, and a series of openings in its walls in operative proximity to said retort, whereby a portion of the main flame from the combustion chamber may be reversed as a result of the eddies formed in said enlargement by the forced action of the flame and caused to impinge upon the retort, substantially as described. 2nd. As an improvement in blow-torch burners, the combination with a retort and means for projecting a vaporized jet therefrom through an opening extending through said retort, of a pear-shaped projection or shell, the interior of which is adapted to form a combustion chamber, the base of said shell being attached to said retort and having an interior diameter larger than that of the opening through said retort, an eduction opening of smaller diameter than that through said retort, and an intermediate enlargement having a series of openings therein in operative proximity to said retort, substantially as described.

**No. 57,425. Dredging Machine. (Machine à draguer.)**

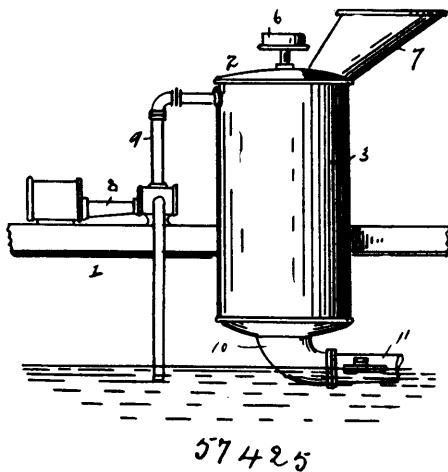

John S. Danens, Carver, Minnesota, U.S.A., 15th September, 1897; 6 years. (Filed 23rd August, 1897.)

*Claim.*—1st. The combination with a dredging machine, of a cylindrical force-pump secured to one side thereof, a shaft rotatably mounted therein, a spirally-arranged blade on said shaft, a chute leading into the upper end of said pump-casing, for admitting dredges to the interior of said casing, a pump for forcing water to the interior of the casing, means for rotating said shaft, a discharge spout upon the lower end of said casing, and a pipe leading from said spout to the shore, substantially as and for the purpose described. 2nd. In a device of the character set forth, the combination with a dredging machine and a force-dump for discharging the dredgings from said machine, of a pipe connected to the lower end of said pump made up of a series of sections, bands of leather and draw-hoops for connecting said sections together, laterally-extending wooden arms on said pipe, and angularly-arranged bracing rods secured to the sides of said pipe section, and to the under sides of said wooden arms whereby the same are adapted to float upon the surface of the water, substantially as and for the purpose set forth.

**No. 57,426. Insoles for Boots and Shoes.**

(Fausse-semelle pour chaussures.)

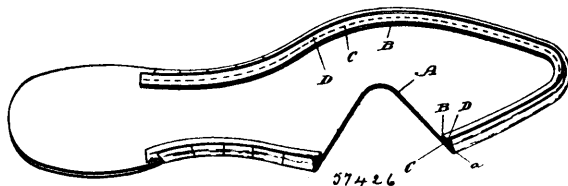

Frank Perry, Toronto, Ontario, Canada, 15th September, 1897; 6 years. (Filed 28th August, 1897.)

*Claim.*—An insole for boots and shoes, consisting of an insole body of the requisite shape and size, and composed of one or more piles of textile fabric material, and a channel strip sewn to the insole contiguous to the edges of the shank ball and toe, substantially as specified.

**No. 57,427. Water Heater. (Chauffeur d'eau.)**

August Buerkle, Troy Hill, Pennsylvania, U.S.A., 16th September, 1897; 6 years. (Filed 30th August, 1897.)

*Claim.*—1st. The combination of a fluid receptacle having supply and outlet pipes, a gas burner for heating the receptacle, a valve for regulating the flow of gas to the burner, a piston adapted to be

shifted on the withdrawal of water from the receptacle and connected to the gas regulating valve, and a valve operated by the

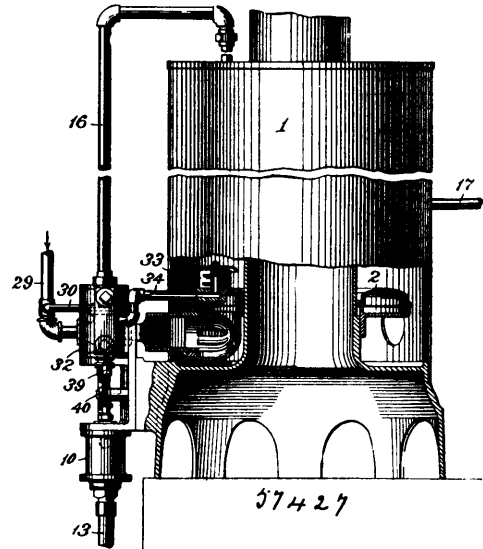

movements of the piston for controlling the flow of water to the heater, substantially as set forth. 2nd. The combination of a fluid receptacle having supply and outlet pipes, a gas burner heating the receptacle, a tapering valve for regulating the flow of gas to the burner, a piston adapted to be shifted by and in accordance with the escape of water from the receptacle, and connected to the valve, and a valve controlling the flow of water to the receptacle and adapted to be shifted by the piston in accordance with its movements, substantially as set forth. 3rd. The combination of a main gas burner, a pilot light burner and means operative on the flow of gas to the main burner and its cut-off therefrom for increasing the flow of gas to the pilot burner, substantially as set forth. 4th. The combination of a main gas burner, a pilot light burner and means operative on the flow of gas to the main burner for increasing the flow of gas to the pilot burner, substantially as set forth. 5th. The combination of a main gas burner, a pilot light burner and means operative on the cut-off of gas from the main burner for increasing the flow of gas to the pilot burner, substantially as set forth. 6th. The combination of a fluid receptacle having inlet and outlet pipes, a cylinder arranged in the line of connection of the inlet pipe, a piston arranged to operate between the inlet and outlet ports of the cylinder, and provided with a passage therethrough, a valve controlling the flow of water through the piston and adapted to be unseated on the movement of the piston, a gas burner for heating the receptacle, and a valve connected to the piston for regulating the flow of gas to the burner, substantially as set forth.

**No. 57,428. Saw Table Gauge. (Jauge de table à scier.)**

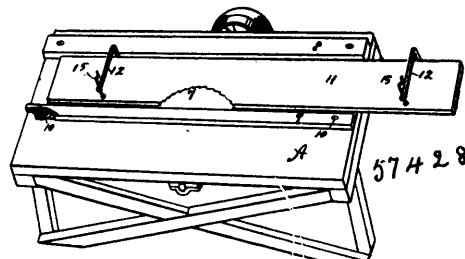

Frank H. Saxton, Bristol, Connecticut, U.S.A., 16th September, 1897; 6 years. (Filed 27th August, 1897.)

*Claim.*—1st. A portable holding-board 11, for a saw-table, said board having a free and unobstructed work holding face for work of indefinite length, straight and parallel edges, and clamping devices for holding the work, said clamping devices being adapted to bear upon that side of work which is opposite the work holding face of said board, substantially as described. 2nd. A saw-table gauge which consists of a portable holding-board 11, having a free and unobstructed work holding face, straight and parallel edges, and the bracket or clamp arm 12, extending up from its longitudinal back edge inside of the gauging-face of said edge, and provided with a clamp screw at its front end for holding the work against the holding face of said board, substantially as described and for the purpose specified.



**No. 57,429. Mechanical Feeder for Ropeway Carriers.**  
(*Alimentateur mécanique pour transport sans fin.*)

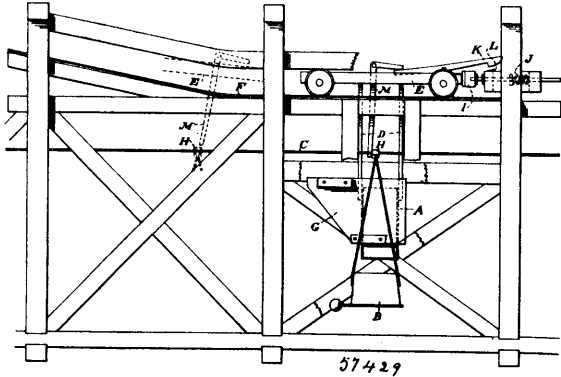

Andrew S. Hallidie, San Francisco, California, U.S.A., 16th September, 1897; 6 years. (Filed 26th August, 1897.)

*Claim.*—1st. A mechanical feeder for travelling carriers consisting of a loading box having an inclined bottom and one open side, a stationary wall against which the open side of the box normally rests, a means for suspending the loading box whereby it is movable in a plane parallel with the fixed partition, and stops by which the loading box is moved away from the wall, and in unison with the movement of the carrier when the latter has reached a point below and opposite the loading box, whereby the contents of the loading box are transferred to the carrier. 2nd. A mechanical feeder for continuously travelling carriers consisting of a chute, an open-topped loading box supplied thereby, said box having an inclined bottom and an open discharge side meeting the lower edge of the bottom, a stationary wall opposite which the loading box normally stands whereby the wall serves to close the open side of the loading box a suspending device to which the loading box is connected and by which it is allowed to move in a plane parallel with the face of the stationary wall so as to uncover its open side, stops fixed respectively to the moving parts and to the loading box connections, whereby the loading box is caused to move in unison with the movement of the carrier when the latter has arrived at a point opposite to and below the loading box. 3rd. In a mechanical feeder for ropeways, a loading box and a means for supplying it with material, said box having an inclined bottom and one open side, a stationary wall lying parallel with the open side and serving to close it while the box is in its normal position, an endless travelling rope and carriers suspended therefrom, a means for suspending the loading box and allowing it to travel parallel with the travelling rope, a stop fixed to the supports of the loading box and a corresponding clip upon the rope whereby contact of the latter with the loading box stop, causes the box to move in unison with the movement of the carrier after the latter has arrived in position beneath and in line with the loading box, and means for disengaging the stop from the clip and returning the loading box to its normal position. 4th. In a mechanical feeder for ropeways, a loading box having an inclined bottom and one open side, a stationary wall against which the open side of the box lies when in its normal position, a stop connected with the box carrier, a means whereby the box may be filled with material to be transferred, a ropeway and carriers movable in line parallel with the face of the stationary wall, a clip fixed upon the rope, a latch adapted to be operated by the stop, said latch normally holding the loading box in position and being disengaged by contact of the clip with the stop, whereby the loading box is moved in unison with the carrier, a means for returning the box automatically to its normal position, a spring whereby the recoil of the loading box is received, the spring compressed, and the latch caused to engage with the holding catch. 5th. In a mechanical feeder for ropeways, a loading box having an inclined bottom and one open side, a stationary wall opposite which the open side of the box normally stands, means for charging the box, a travelling rope and carriers suspended therefrom, clips upon the rope and a latch and stop whereby when the clip makes contact with the stop the loading box is unlatched and impelled forward in the line of travel of the rope, the open side is moved beyond the stationary wall, and the contents of the loading box delivered into the carrier beneath, a suspending device for the loading box whereby it is carried above the line of travel of the clip and rope, and is disengaged from the stop on the box and the latter is released and allowed to return by gravitation to its normal position. 6th. In a mechanical feeder for ropeways, a movable loading box having an inclined bottom and an open side, and a stationary wall, to form a closure for the open side when the box is in position to be charged.

**No. 57,430. Charging Machine for Open Hearth Furnaces.**  
(*Machine à alimenter les fournaies.*)

Joseph Paul Eck, Muncie, Indiana, U.S.A., 16th September, 1897  
6 years. (Filed 27th August, 1897.)

*Claim.*—1st. A furnace charging apparatus consisting of a charger track adapted to travel across the face of the furnace, a charger frame

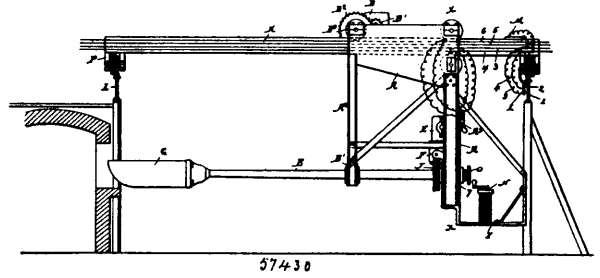

adapted to run upon said track, a charger bar pivotally suspended within said frame, means for raising and lowering the outer end of said charger bar, and suitable electric motors in proper circuit for operating the various parts of the apparatus, as specified. 2nd. In combination, supporting tracks arranged parallel with the front of the furnace, a charger track mounted upon trucks adapted to travel upon said supporting tracks, a charger frame, a truck from which said frame is suspended, said truck being adapted to run upon the charger track, a casting suitably pivoted within the charger frame a charger bar journaled within said pivoted casting, a vertically movable casting fitted to slide within the charger frame, and through which the charger bar passes, and mechanism for revolving the charger bar, an electric motor for operating said mechanism, and an electric motor for causing the charger truck to travel upon its track, and an electric motor for causing the charger track to move to and fro upon the supporting track, as specified. 3rd. In combination with a furnace of the character described, two supporting tracks arranged parallel with the face of said furnace, trucks adapted to travel upon said tracks, a charger track mounted upon said truck, an electric motor for causing these trucks to travel, suitable gearing for connecting said motor with said trucks, a trolley carried by one of the trucks and adapted to run upon suitable line wires, a charger truck adapted to run upon the charger track, an electric motor carried thereby, a gearing for connecting said motor with these truck wheels, a trolley carried by this last named truck for putting the motor in circuit with suitable line wires, and a charger frame suspended from the last named truck carrying suitable mechanism for charging the furnace, as shown and described. 4th. In combination with a charging apparatus of the character described, two charging tracks, two trucks adapted to run thereon, a charger track supported upon said trucks, suitable gearing for operating these trucks, a rod for connecting the gearing with the two trucks, an electric motor for operating this gearing, and a trolley carried by one of the trucks and adapted to run upon suitable line wires by which an electric current is carried to and from the motor, as shown and described. 5th. In combination with a traveling charger track of the character described, a truck adapted to run thereon, an electric motor carried by said truck, suitable gearing connecting the wheels of said truck with said motor, a trolley carried by the truck and adapted to travel upon suitable line wires for transmitting an electric current to and from said motor, a charger frame depending from the truck, a casting pivoted within the frame, a hollow charging bar journaled within said casting, a vertically movable casting in which the rear end of the charger bar is journaled, suitable mechanism for raising and lowering said casting, an electric motor for operating said mechanism, a trolley carried by the charger frame for transmitting an electric current from suitable line wires, and a platform containing the controller and switchboards upon which the operator may stand for bringing about the proper movements of the charger, substantially as shown and described. 6th. In combination with a charger frame of the character described, a casting pivoted to said frame, a hollow charger bar journaled in said pivoted casting, a vertically movable frame fitted to slide within the charger frame, and in which the rear end of the charger bar is journaled, suitable mechanism for raising and lowering said frame, an electric motor carried by the charger frame for operating this last named mechanism, suitable gearing connected with the charger bar for turning the same upon its axis, an electric motor suitably mounted for operating this gearing, suitable trolleys for transmitting an electric current from line wires to the motors, a cam rod journaled with the hollow charging bar, a cam carried upon the inner end thereof adapted to enter into engagement with the shank of the charging pan, thereby locking the same upon the charger bar, a hand wheel for the outer end of the cam rod for manipulating the same, and a platform upon which the operator may stand for controlling the movements of the apparatus, as specified. 7th. In combination with a charger frame of the character described, a charger bar pivotally attached thereto, mechanism for raising and lowering the outer end thereof, mechanism for turning said charger bar upon its axis, a charger pan with which the outer end of the charger bar is adapted to engage, a rod journaled within the hollow charger bar, a cam carried upon the inner end thereof, and adapted to enter into engagement with the shank of the charging pan for locking the same upon the charger bar, and means for bringing about the several movements of the

charger bar, as shown and described. 8th. In combination with a hollow charging bar of the character described, a rod journaled therein, a cam carried upon the inner end of said rod and adapted to be turned upward through an opening in said bar, a hand wheel for manipulating said rod, and a charging pan having a shank in which is formed a square hole for the entrance of the square end of the charger bar and also having a notch formed therein with which the cam may engage for locking the pan upon the charger bar, substantially as and for the purpose set forth. 9th. In combination with a charging apparatus of the character described, a platform carried by the charger frame upon which the operator may stand, and a controller and other electric switch mechanism arranged upon said platform within easy reach of said operator, substantially as shown and described.

**No. 57,431. Tool for Removing Nails and Pegs.**

(Appareil à extraire les clous, etc.)

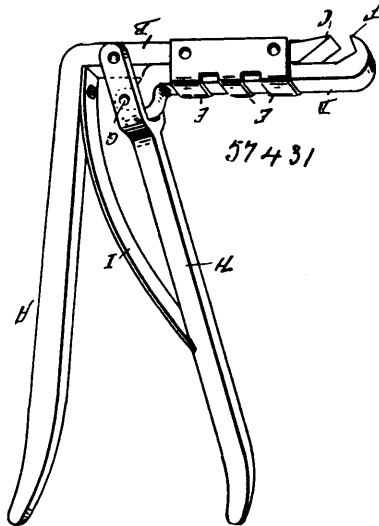

Edward McLean, Fort Scott, Kansas, U.S.A., 16th September, 1897; 6 years. (Filed 23rd August, 1897.)

*Claim.*—1st. In a tool for cutting off projections in the bottom of the inside of boots and shoes, the combination with a fixed handle having an arm rigidly attached approximately at a right angle thereto at its lower end, said arm terminating in a bevelled cutting edge, of an arm longitudinally movable upon and held in position on said fixed arm and having its outer end turned down and back, and terminating in a knife edge registering with the cutting edge of the arm on which it rests, its opposite end hinged to a lever pivoted to said fixed arm near its point of attachment to said handle, and the lever held normally apart from said handle by a spring, substantially as shown and described. 2nd. A tool for cutting nails, pegs and screws from the inside of boots and shoes, having a fixed handle with a flat arm rigidly formed at a right angle thereto adapted to rest on the bottom of the inside of the boot or shoe and terminating in a bevelled edged knife formed with the bevel on the upper side thereof, an arm adapted to slide thereon held in position with loops, its outer end turned down and back, terminating in a knife edge adapted to register with the edge of the knife on the arm to which it is looped, its inner end hinged in the bifurcated end of a lever pivoted to the arm of the fixed handle near its point of attachment to the said handle and held normally apart therefrom by a leaf-spring, substantially as shown and described.

**No. 57,432. Device for Issuing Tickets, Receipts, etc.**

(Appareil pour l'émission des billets, etc.)

Charles Otto Tangeman, Fern Bank, Ohio, U.S.A., 16th September, 1897; 6 years. (Filed 3rd August, 1897.)

*Claim.*—1st. In a ticket or receipt-issuing device, the combination, with a suitable base, of a swinging frame, and a series of overlapping straight edges adjustable on the frame and having their cutting edges in the same plane, substantially as and for the purpose set forth. 2nd. In a ticket or receipt-issuing device, the combination, with a suitable base, of a swinging frame, a series of overlapping straight edges adjustable on the frame and having their cutting edges in the same plane, and spring or springs adapted to normally hold the frame in a raised position, substantially as and for the purpose set forth. 3rd. In a ticket or receipt-issuing device, the combination of a table, a slotted frame pivoted thereto

and carrying a series of adjustable and overlapping straight edges, an opening in the table, and a platform carried by the frame adapted

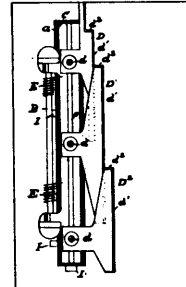
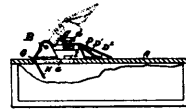

to swing into the opening when the frame is raised and away from the opening when the frame is lowered, substantially as and for the purpose set forth. 4th. The combination, in a ticket or receipt-issuing device, of a table, a slotted frame pivoted thereto and carrying a series of adjustable and overlapping straight edges, an opening in the table, a platform carried by the frame adapted to swing into the opening when the frame is raised and away from the opening when the frame is lowered, and guides adapted to hold each ticket or receipt in the same position relative to the cutting edges, substantially as and for the purpose set forth.

**No. 57,433. Cooking Pan. (Poëlon.)**

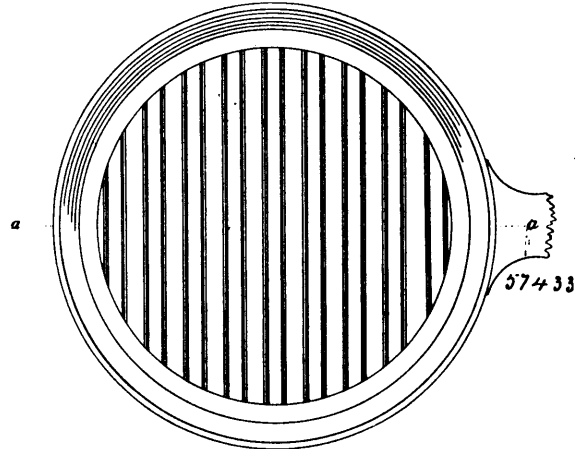

William Hayward, Moncton, New Brunswick, Canada, 16th September, 1897; 6 years. (Filed 26th August, 1897.)

*Claim.*—A cooking pan with a corrugated bottom, constructed substantially as described and for the uses and purposes hereinbefore specified.

**No. 57,434. Apparatus for Detaching Electric Lamp Bulbs. (Appareil pour enlever les bulbes de lampes électriques.)**

Oleny Smith, Detroit, Michigan, U.S.A., 16th September, 1897; 6 years. (Filed 20th April, 1897.)

*Claim.*—1st. In a lamp-detacher, a flexible shaft provided with means for engaging the lamp, and means for rotating said shaft, substantially as described. 2nd. In an electric-lamp detacher, a flexible shaft, springs to engage a lamp-bulb, a swivel connections adapted to engage lamps at different angles, and means for rotating said shaft and springs substantially as described. 3rd. In a lamp-detacher, a flexible shaft working in a suitable handle, a swivel connection, suitable means for engaging the lamp and means to rotate

the flexible shaft, substantially as described. 4th. In a lamp-detacher, a flexible shaft, springs to engage a lamp-bulb, said springs

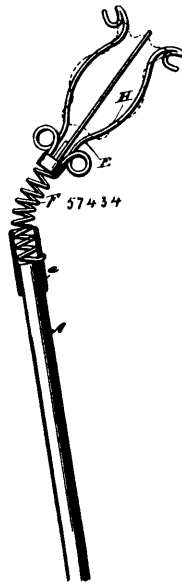

covered with rubber or other material adapted to offer frictional engagement with said lamp-bulb, and means for rotating said flexible shaft, substantially as described.

**No. 57,435. Car Coupler. (Attelage de chars.)**

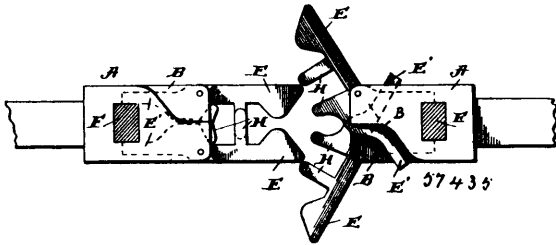

Robert D. Green, Simpson, Pennsylvania, U.S.A., 16th September, 1897; 6 years. (Filed 28th August, 1897.)

*Claim.*—1st. An improved coupling, comprising a draw-head, two jaws pivoted in the draw-head to swing horizontally in opposite directions when opening and also when closing, and a vertically movable locking pin in the draw-head and arranged centrally between the jaws and to the rear of their pivotal points, the jaws engaging opposite sides of the pin when in locked position, substantially as shown and described. 2nd. An improved coupler consisting of a draw-head, two jaws pivoted between their ends therein and adapted to open by swinging horizontally in opposite directions, and a vertically moving locking pin formed with oppositely inclined transverse recess through which the rear ends of the jaws are adapted to pass in moving to a locked position, substantially as shown and described. 3rd. An improved coupler consisting of a draw-head recessed inward from opposite sides, one recess being above the other, oppositely opening jaws pivoted between their ends in the recesses with their tail pieces working therein, and a locking device adapted to be operated by the jaws when closing or interlocking with an adjacent coupler, substantially as shown and described. 4th. The combination of a draw-head consisting of the rear part A and recessed projecting parts B, the draw-head being formed with a vertical passage partly in portion A and partly in portion B, the oppositely swinging jaws pivoted between their ends in the recesses of parts B with their tail pieces working across the line of the vertical passage, and the pin adjustable vertically in said passage and formed with oppositely inclined passages on its front face in line with the recesses of parts B, whereby the pin is automatically operated by the tail pieces of the jaws, substantially as shown and described. 5th. An improved coupling, comprising a draw-head, two jaws pivoted therein in different horizontal planes and adapted to swing horizontally in opposite directions when opening and also when closing, the pivotal points of the jaws being between their ends, and a vertically movable locking device arranged centrally between the jaws and to the rear of the pivots thereof and adapted to be set by the movement of the rear ends of the jaws, either singly or in unison, substantially as shown and described.

**No. 57,436. Box Machine. (Machine à boîtes.)**

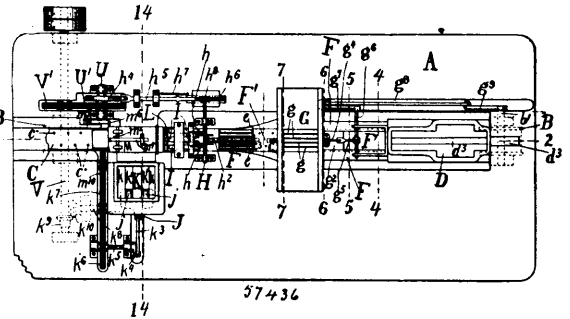

Charles Wallace Van Vleet and James Phillips Osborne, both of Rochester, New York, U.S.A., 16th September, 1897; 6 years. (Filed 14th August, 1897.)

*Claim.*—1st. The combination of a continuously-moving box-carrier, devices for folding a blank while in motion to form a box, and mechanism co-operating with said box-carrier for inserting the formed box into a cover. 2nd. The combination of a continuously-moving box-carrier, devices for completely folding a blank while in motion to form a box, devices for filling the box while in motion, and mechanism for inserting the formed and filled box into a cover. 3rd. The combination of a moving box-carrier, devices for completely folding a blank while in motion upon said carrier to form a box, and mechanism co-operating with said carrier for inserting the formed box, while upon said carrier, into a cover. 4th. The combination of a moving box-carrier, devices co-operating therewith for completely folding a blank while upon said carrier to form a box, other devices co-operating with said carrier for filling the box while in motion thereon, and mechanism co-operating with said carrier for inserting the formed and filled box into a cover. 5th. The combination, with a box-channel, of mechanism for delivering a box-blank thereto, mechanism for moving the blank in said channel, mechanism for completely forming the box from said blank while in motion, mechanism for filling said box while in motion, and mechanism for inserting the formed box into a cover. 6th. The combination with a box-channel, of mechanism for delivering a box-blank thereto, mechanism for moving the blank in said channel, devices for forming first the sides and then the ends of the box from the blank while in motion, mechanism for filling said box while in motion, and mechanism for inserting the formed box into a cover. 7th. The combination of a continuously-moving box-carrier, mechanism for delivering a box-blank thereto, devices for completely forming a box from the blank while in motion upon said carrier, and mechanism co-operating with said carrier for inserting the formed box into a cover. 8th. The combination, with a box-channel, of mechanism for delivering a box-blank thereto, mechanism for moving the blank in said channel, guides acting on said blank and gradually bending the blank to form the sides of the box, mechanism for bending the ends of the blank to form the ends of the box, and mechanism co-operating with the mechanism for moving the blank in said channel for inserting the formed box into a cover. 9th. The combination, with a box-channel, of mechanism for feeding a box-blank thereto, mechanism for moving the blank in said channel, guides acting on said blank and gradually bending the ends of the blank to form the sides of the box, mechanism for bending the ends of the blank to form the ends of the box, and mechanism co-operating with the mechanism for moving the blank in said channel for inserting the formed box into a cover. 10th. The combination, with a box-channel, of mechanism for feeding a box-blank thereto, mechanism for removing the blank continuously in said channel, guides acting on said blank for gradually bending parts of the blank to form the sides of the box, mechanism for bending other parts of the blank to form both ends of the box, and mechanism for inserting the formed box into a cover. 11th. The combination of a continuously-moving box-carrier, a box-channel wherein said carrier moves, mechanism for forming the sides and ends of the box-blank while in motion to form a box, and mechanism of which said box-carrier is an element for applying a cover to the formed box. 12th. The combination, with a box-channel, of mechanism for delivering a box-blank thereto, mechanism for moving the blank continuously in said channel, guides acting on said blank for gradually bending parts of the blank to form the sides of the box, mechanism for filling the box while in motion, mechanism for bending the blank to complete the box while in motion, and mechanism for inserting the formed box into a cover. 13th. The combination of a continuously-moving carrier, mechanism for delivering a box-blank thereto, means for retaining said blank upon said carrier, mechanism for partly folding said box-blanks, mechanism for placing the filling material upon said blanks, mechanism for completely folding said blanks, and mechanism for inserting the filled and folded blanks into a cover, all during continuous movement of said blank. 14th. The combination of a magazine containing flat box-blanks, a continuously-moving carrier and mechanism connected therewith for removing said

box-blanks one by one from said magazine, a box channel wherein said carrier moves, mechanism for forming the sides and ends of said box while in motion, and mechanism for applying a cover to said box. 15th. The combination of a magazine containing flat box-blanks, a continuously-moving carrier and mechanism connected therewith for removing said blanks one by one from said magazine, mechanism for forming the sides and ends of the box from a blank while in motion, and mechanism for inserting a folded blank into a cover. 16th. The combination of a magazine containing flat box-blanks, a continuously-moving carrier and mechanism connected therewith for removing said blanks one by one from said magazine, means for retaining said blanks upon said carrier, mechanism for forming the box from a blank while in motion, and mechanism for inserting the formed box into a tubular cover. 17th. The combination of a magazine adapted to contain flat box-blanks, a continuously-moving carrier and mechanism thereon for receiving said blanks one by one from said magazine, a channel for retaining said blanks on said carrier, guides in the sides of said channel for forming the sides of the box from the blank, mechanism upon said carrier for forming one end of the box from the blank, mechanism co-operating with said carrier for forming the other end of said box from said blank, a magazine containing tubular covers for said boxes, mechanism for extracting the covers one by one from the magazine and for inserting the same in the path of motion of said box, means for retaining the said cover in said path while the box is being inserted thereinto, and means for releasing the box when inserted in said cover. 18th. The combination, with a box-carrying mechanism, of mechanism for discharging the box-filling material into the moving box with substantially the same velocity as that of the box, and means for delivering each filled box from said carrier. 19th. The combination with a continuously-operating box-carrying mechanism, of mechanism for discharging the box-filling material into the moving box with substantially the same velocity as that of the box and in the same direction and means for delivering each filled box from said carrier. 20th. The combination with a moving box-carrying mechanism, of a magazine box-filling material and mechanism for discharging a charge of the box-filling material from said magazine into the box, while in motion, and in the same direction as said motion, and means for delivering each filled box from said carrier. 21st. The combination with a moving box-carrying mechanism, of a magazine for the box-filling material and mechanism for discharging the box-filling material from said magazine into the box, while in motion, and in the same direction as said motion, and mechanism for co-acting with said box-carrying mechanism for applying a cover to said box while the same is in motion. 22nd. The combination with a box-carrying mechanism, of mechanism for first measuring a charge of the box-filling material and then discharging said charge into a box, while moved by said carrying mechanism, in the same direction as the motion of said box and means for delivering each filled box from said carrier. 23rd. The combination with a box-carrying mechanism for first measuring a charge of the box-filling material and then discharging said charge into a box, while moved by said carrying mechanism, in the same direction as the motion of said box, and mechanism co-acting with said box-carrying mechanism for applying a cover to said box while moved by said carrier. 24th. The combination with a continuously operating box-carrying mechanism, of mechanism for measuring and discharging the box-filling material into the moving box with substantially the same velocity as that of the box and in the same direction, and means for delivering each filled box from said carrier. 25th. The combination with a continuously-moving box-carrying mechanism, of mechanism for discharging the box-filling material from a magazine into the moving box with substantially the same velocity as that of the box and in the same direction, and mechanism for covering said box. 26th. The combination with a continuously-operating box-carrying mechanism, of mechanism for feeding box-blanks thereto, mechanism for discharging the box-filling material into the partly formed moving box with substantially the same velocity as that of the box and in the same direction, mechanism for completely forming the box, and mechanism for covering the box, all while said box is in continuous motion. 27th. The combination of a magazine containing flat box-blanks, a continuously-moving belt having a device thereon for removing said blanks one at a time from said magazine and for retaining the same on said belt, a box-channel of which said belt is the bottom, means for folding the sides of said box from said blank, and means for folding the ends of said box, all while the box is in continuous motion. 28th. The combination of a magazine adapted to contain flat box-blanks and having an aperture for the passage of the blanks therefrom, a continuously-moving belt having a series of devices thereon for removing said blanks one at a time from said magazine and for moving the same with said belt, a box-channel of which said belt is the bottom, devices for folding the ends of said box and devices for inserting the folded box in a cover, all while the box is in continuous motion. 29th. The combination of a magazine adapted to contain flat box-blanks and having an aperture for the passage of the blanks therefrom, a continuously-moving belt having a series of devices thereon for removing said blanks one at a time from said magazine and for moving the same with said belt, a box-channel of which said belt is the bottom, devices for folding the sides of said box from said blank, devices for discharging a measured quantity of

the box-filling material into said box, mechanism for folding the ends of said box, and mechanism for inserting the filed and folded box in a cover, all while the box is in continuous motion. 30th. The combination of a magazine adapted to contain flat box-blanks and having an aperture for the passage of the blanks therefrom, a continuously-moving belt having a series of devices thereon for removing said blanks one at a time from said magazine and for moving the same with said belt, a box-channel of which said belt is the bottom, the sides of the channel being formed to fold the sides of the blank to form the sides of the box, a device upon said belt for folding one end of said box, a folder for folding the other end of said box, a magazine for box-covers, means for withdrawing one cover at a time therefrom, means for interposing a cover in the path of said folded box, means for retaining the cover in position while the box is being inserted thereinto, and means for releasing the covered box, all while the box is in continuous motion. 31st. The combination of a moving box-carrier, devices for folding a blank while in motion to form a box, and mechanism co-acting with said box-carrier for inserting the formed box, while moved by said carrier, into a cover. 32nd. The combination of a continuously moving box-carrier, devices for folding a blank while in motion to form a box, and mechanism co-acting with said box-carrier for inserting the formed box, while moved by said carrier into a cover. 33rd. The combination of a moving box carrier, devices co-operating therewith for completely folding a blank to form a box, and other devices co-operating with said carrier for filling the box, while moved by said carrier, with a charge of material which is discharged into the box by said last-named devices in the same direction as the movement of the box. 34th. The combination of a moving box-carrier, devices co-operating therewith and external to the box-blanks for folding a blank to form a box, and other devices co-operating with said carrier for inserting a measured charge of box-filling material into said box while moved by said carrier. 35th. The combination of a continuously-moving box-carrier, mechanism for automatically delivering a box-blank thereto, devices for forming a box from the blank while moved by the said carrier, and mechanism co-acting with said carrier for inserting the formed box, while moved by said carrier, into a cover. 36th. The combination with a box-channel, of mechanism for moving a series of boxes successively in said channel, a magazine for the box-filling material, and mechanism for automatically discharging a charge of the box-filling material from said magazine into each box while in motion, and in the same direction as said motion, and means for delivering each filled box from said carrier. 37th. The combination with a box-channel, of mechanism for moving a series of boxes successively in said channel, a magazine for the box-filling material, and mechanism for automatically discharging a charge of the box-filling material from said magazine into each box while in motion, and in the same direction as said motion, and mechanism, co-acting with said mechanism for moving said series of boxes, for applying a cover to each box. 38th. The combination with a box-carrying mechanism, of a magazine adapted to contain a series of separated vertical columns of cigarettes or other like-formed objects, and having a discharge-orifice at the base of said columns of such size as to permit the exit of a definite number of such objects, mechanism operating in time with said box-carrying mechanism for discharging said number of said objects through said orifice into the box as it moves from under said orifice and while in motion, said objects being discharged in the same direction as the motion of said box, and with substantially the same velocity. 39th. The combination, with a box-carrying mechanism, of a magazine adapted to contain a series of separated vertical columns of cigarettes or other like-formed objects, and having a discharge-orifice at the base of said columns of such size as to permit the exit of a definite number of such objects, mechanism operating in time with said box-carrying mechanism for discharging said number of said objects through said orifice into the box as it moves from under said orifice and while in motion, said objects being discharged in the same direction as the motion of said box, and with substantially the same velocity, and mechanism co-acting with said box-carrying mechanism for applying a cover to said box while moved by said carrier. 40th. In a box-machine, the combination, with devices, as the guides F, F, and folders  $c^2$  and  $h$ , for folding blanks to form boxes, a magazine D for said blanks having an exit-orifice  $d^2$  at the base for a single blank and a slotted bottom  $d$ , of a series of pickers  $c$  for removing one blank at a time, each having a head  $c^2$  provided with a forward edge, a travelling support, as the belt C, adapted to co-operate with said folding devices, and bearing said series of pickers, and movable to carry said heads through said slot, a spring as  $c^1$  interposed between said head and said support, and means located at or about the entrance of said slot and over the path of said head adapted to depress the same, whereby said spring is compressed and said edge is caused to enter between the lowest blank in said magazine and the next superior blank. 41st. In a blank-delivering device, the combination of a magazine, as D, adapted to contain blanks, and having an exit-orifice  $d^2$  at the base for a single blank, and a slotted bottom  $d$ , a series of pickers  $c$  for removing one blank at a time from said magazine, each having a head  $c^2$  provided with a forward edge, a support, as the belt C, adapted to carry said series of pickers, and movable to carry said heads through said slot, a bow-spring, as  $c^1$ , fastened at one end to said support, and resting freely on said support at the other end, and raised from said support in the middle, and having said head  $c^2$  fastened upon the highest point of said spring, means located at or

near the entrance of said slot and near the path of said head, and adapted to depress the same, whereby said spring is compressed and said edge is caused to enter between the lowest blank in said magazine and the next superior blank. 42nd. In a box-machine, the combination of devices for folding blanks to form boxes, a magazine, as D, adapted to contain blanks, and having an exit-orifice  $d^2$  at the base for a single blank, and a slotted bottom  $d$ , a series of pickers  $c$  for removing one blank at a time from said magazine, each having a head provided with a forward edge, a travelling support adapted to co-operate with said folding devices, and bearing said series of pickers, and movable to carry said heads through said slot, a bow-spring, as  $c^1$ , fastened at one end to said support, and resting freely on said support at the other end, and raised from said support in the middle, and having said head fastened upon the highest point of said spring, means located at or near the entrance of said slot and near the path of said head, and adapted to depress the same, whereby said spring is compressed and said edge is caused to enter between the lowest blank in said magazine and the next superior blank, together with devices co-operating with said travelling support for applying a cover to the folded box. 43rd. The combination of a box-carrier, devices for operating externally upon a moving blank, for folding the same to form an open box, and mechanism co-acting with said box-carrier for inserting the formed box, while moved by said carrier, into a cover. 44th. The combination of a moving box-carrier, means for automatically delivering successive box-blanks thereto, devices external to the blanks and co-operating with said carrier to fold each blank while in motion, to form an open box adapted to receive filling material, and devices for filling the box, while moved by said carrier, with a charge of material which is discharged into the box in the same direction as the movement of the box. 45th. The combination of a continuously-moving box-carrier, mechanism for delivering successive box-blanks thereto, devices external to said blanks and co-operating with said box-carrier, to fold each blank to form an open box while in motion upon the said carrier adapted to receive filling material, devices for filling the box while moved by said carrier with a charge of material, which is discharged into the box in the same direction as the motion of the box, and mechanism co-acting with said carrier for inserting the formed box, while moved by said carrier, into a cover. 46th. The combination, with a box-carrier and devices co-operating therewith for forming boxes from blanks carried thereby, of mechanism adapted to open a collapsed cover and to retain the same in the path of said box-carrier, whereby the box is inserted into said cover, together with an apparatus for automatically delivering collapsed covers, one by one, into said mechanism. 47th. The combination, with devices for advancing a formed box endwise, of a cover-holder which receives the flattened tubular cover, means whereby a part of the holder is caused to open said cover and to retain the opened cover in the path of the advancing box. 48th. The combination, with devices for advancing a formed box endwise, of a cover-holder which receives the flattened tubular cover, means whereby a part of the holder is caused to open said cover and to retain the opened cover in the path of the advancing box, together with an independent mechanism for feeding flattened covers, one by one, into said cover-holder. 49th. The combination with devices for advancing a formed box endwise, of a cover-holder which receives a flattened tubular cover, means whereby the holder opens to receive the same and, by closing, opens said tubular cover and holds the same in the path of the advancing box, together with an independent mechanism for feeding such flattened covers, one by one, into said cover-holder. 50th. The combination, with devices for advancing a formed box endwise, of a cover-holder set in the path of such advancing box and having an opening side, a magazine for tubular covers, a plunger, provided with devices for extracting one cover at a time from said magazine, for moving said cover directly into said cover-holder, and means for securing said tubular cover inside said cover-holder and for retaining the same in the path of said advancing box. 51st. The combination, with mechanism for advancing a formed box endwise, of a cover-holder in the path of said advancing box and having a hinged side and adapted to receive a flattened tubular cover through the opened side and to open the cover by closing said side, and independent devices for feeding flattened covers through said opened side. 52nd. The combination, with mechanism for advancing a formed box endwise, of a cover-holder in the path of said advancing box and having an opening side and adapted to receive a flattened tubular cover through the opened side and to open the cover by closing said side, in combination with devices for feeding flattened covers through said opened side into the path of the said advancing box, and a gate on the end of said cover-holder adapted to close and retain the cover therein until the box is inserted and then to open for the discharge of the covered box. 53rd. In a box-machine, a magazine adapted to contain flattened tubular covers and having a throat adapted to permit only one flattened cover to emerge therefrom, a box-carrier adapted to advance formed boxes endwise, a cover-holder in the path of said box-carrier having an open end on the side of the approaching box and an opening side adjacent to said throat, devices for removing flattened covers, one at a time, from said magazine and for delivering the same through the opening side into said cover-holder, and means for opening and closing said opening side, whereby said cover is admitted into and is opened and secured inside the cover-holder and in the path of the advancing box. 54th. The combination, with a box-carrier adapted

to advance box-blanks longitudinally thereon and means of folding the sides and ends of box-blanks substantially of the form described, of mechanism for folding the top flaps of such box-blanks consisting of a folder-wheel, placed above the path of motion of the box and at a height to come in contact with the said top flaps and revolving in direction to fold the flaps down upon the moving boxes in the same direction as the motion of the boxes. 55th. The combination, with a box-carrier adapted to advance box-blanks longitudinally thereon and means of folding the sides and ends of box-blanks substantially of the form described, and mechanism for folding the top flaps of such box-blanks, consisting of a folding wheel having a serrated periphery placed above the path of motion of the box and at a height to strike said top flaps and revolving in a direction to fold the flaps down upon the moving boxes in the same direction as the motion of the boxes. 56th. The combination, with a box-carrier adapted to carry box-blanks of the form described longitudinally thereon, means for folding the sides and ends of said box-blanks, means for folding the top flaps of said blanks upon said box while in motion, consisting of the lifting folder-wires  $h$ ,  $h$ , and one or more folder-wheels, as  $H^3$ ,  $H^5$ , placed above the path of motion of the box and at a height to come in contact with said top pieces and to fold the rear flap upon the moving box in the same direction as the motion of the carrier and revolving more rapidly than the motion of the box-carrier. 57th. The combination with a box-carrier adapted to carry box-blanks of the form described longitudinally thereon, means of folding the sides and ends of said box-blanks, means for folding the top flaps of said blanks upon said box while in motion, consisting of the lifting folder wires  $h$ ,  $h$ , and one or more folder-wheels as  $H^3$ ,  $H^5$ , placed above the path of motion of the box and at a height to come in contact with said top flaps and to fold the rear flap upon the moving box in the same direction as the motion of the box-carrier and revolving more rapidly than the motion of the box-carrier, and means for inserting the folded box-blanks into a tubular cover. 58th. The combination of a box-carrier adapted to carry box-blanks of the form described longitudinally thereon and means for holding the side wings of the blank, the folder-rods  $h$ ,  $h$ , operated substantially as described to lift and fold the flap  $e^1$ , and one or more folder-wheels, as  $H^3$  and  $H^5$ , having arms peripherally revolving at greater velocity than the velocity of the box-carrier and adapted to fold down the flap  $e^3$  in the same direction as the motion of the carrier. 59th. In a box-machine, the combination of a channel having stationary sides changing gradually from horizontal to vertical, means for directing flat box-blanks having wing-pieces to form the sides and ends thereof into said channel at or before the point where the sides of the channel change from the horizontal, a belt moving continuously in said channel and provided with mechanism external to the blanks for moving the separate blanks longitudinally along in said channel, whereby the sides are folded, and means for folding both ends of the box. 60th. In a box-machine, the combination of a channel having stationary sides changing gradually from horizontal to vertical, means for directing flat box-blanks having wing-pieces to form the sides and ends thereof into said channel at or before the point where the sides of the channel change from the horizontal, a box-carrier moving in said channel and provided with mechanism for moving the separate blanks longitudinally in said channel whereby the sides are folded, and means for folding the front and rear ends of the box. 61st. In a box-machine, the combination of a channel having stationary sides changing gradually from horizontal to vertical, means for directing flat box-blanks having wing-pieces to form the sides and ends thereof into said channel at or before the point where the sides of the channel change from the horizontal, a box-carrier moving in said channel and provided with mechanism for moving the separate blanks longitudinally in said channel whereby the sides are folded, and means for folding the front and rear ends of the box. 62nd. In a box-machine, the combination of a channel having stationary sides changing gradually from horizontal to vertical, means for directing flat box-blanks having wing-pieces to form the sides and ends thereof into said channel at or before the point where the sides of the channel change from the horizontal, a box-carrier moving in said channel and provided with mechanism for moving the separate blanks longitudinally in said channel whereby the sides are folded, means for folding the front and rear ends of the box, and a cover-holder set over said box-carrier and adapted to receive and hold a cover for said box, whereby the cover is applied to the box as the latter is moved along by said carrier. 63rd. In a box-machine, the combination of a channel having stationary sides changing gradually from horizontal to vertical, means for directing box-blanks having wing-pieces to form the sides and ends thereof into said channel at or before the point where the sides of the channel begin to change from the horizontal, and a carrier moving in said channel, whereby the sides are folded, one or more depressible transverse folders upon said belt, means for raising each folder to form one end of the box, and means for forming the other end of the box. 64th. In a box-machine, the combination of a channel having stationary sides changing gradually from horizontal to vertical, means for directing box-blanks having wing-pieces to form the sides and ends thereof into said channel at or before the point where the sides of the channel begin to change from the horizontal, and a carrier moving continuously in said channel whereby the sides are folded, one or more depressible transverse folders upon said carrier, means for raising each folder to form the rear end of a box, and a lifting-folder adapted to catch, raise and



fold the forward end of the box while in motion. 65th. In a machine for forming boxes from flat cruciform blanks consisting, substantially, of a centre E, wings e, e, to form the sides, wings e<sup>2</sup>, e<sup>4</sup> to form the ends of the box, an extended flap e<sup>1</sup> on one end of the blank to form one part of the top and a flap e<sup>3</sup> on the other end of the blank to complete the top, means for delivering said flat blanks one at a time to a continuously-moving carrier with the flap e<sup>1</sup> forward, a channel in which said carrier moves having sides changing gradually from horizontal to vertical whereby the wings e, e, are gradually bent to form the sides of the moving box, one or more depressible folders upon said carrier, means for raising each folder to bend the rear wing e<sup>2</sup> to form one end of the box, and a lifting-folder adapted to catch and lift the forward end of the flap e<sup>1</sup> with the end e<sup>4</sup> and to bend the same and to raise said flap and end into the vertical position, and then to bend down the flap e<sup>1</sup>, and means as a revolving wheel or wiper, moving with greater peripheral velocity than the belt, for striking and bending the flap e<sup>3</sup> over the box, and means for inserting the folded box into a cover. 66th. The combination of a moving box-carrier, devices for folding a blank while in motion upon said carrier to form a box, and means for holding a tubular cover in the line of movement of the carrier whereby the box is inserted into the cover by the movement of the carrier. 67th. The combination of a moving box-carrier, devices for folding a blank while in motion upon said carrier to form a box, devices for filling the box while in motion, and means for holding a tubular cover in the line of movement of the carrier whereby the box is inserted into the cover by the movement of the carrier. 68th. The combination of a moving box carrier, devices co-operating with said carrier for folding a blank to form a box, means for holding a tubular cover in the line of movement of the carrier whereby the box is inserted into the cover by the movement of the carrier, and means for releasing the covered box from said holding device. 69th. The combination of a moving box carrier, devices co-operating with said carrier for folding a blank to form a box, other devices co-operating with said carrier for filling the box while in motion thereon, means for holding a tubular cover in the line of movement of the carrier whereby the box is inserted into the cover by the movement of the carrier, and means for releasing the covered box from said holding device. 70th. The combination of a magazine adapted to contain flat box-blanks, a continuously moving belt having a device thereon for removing said blanks one at a time from said magazine and for retaining the same on said belt, a box-channel of which said belt is the bottom, means for folding the sides of said box from said blank, means for folding the ends of the box, means for holding a tubular cover in the line of movement of the belt whereby the box is inserted into the cover by the movement of the belt, and means for releasing the covered box from said holder, all while the box is in continuous motion. 71st. The combination of a magazine adapted to contain flat box-blanks, a moving belt having devices thereon for removing said blanks one at a time from said magazine, and for retaining the same on said belt, a box-channel of which said belt is the bottom, means for folding the sides of said box from said blank, and means for folding the ends of said box, all while the box is moved by said belt. 72nd. The combination with a box channel, of mechanism for delivering a box-blank thereto, a mechanism for moving the blank in said channel, guides acting on said blank and gradually bending the blank to form the sides of the box, and mechanism for bending the ends of the blank to form the ends and top of the box, whereby to form a completely closed box without apparatus acting internally on said blank. 73rd. The combination of a moving box carrier adapted to carry a series of box-blanks, mechanism co-operating with said carrier for bending the blank to form the sides of the box, mechanism for bending the ends of the blank to form the ends and top of the box whereby to form a completely closed box without apparatus acting internally on said blank.

**No. 57,437. Swage for Upsetting Teeth of Saw-Mills.**  
(Machine à étamer les scies.)

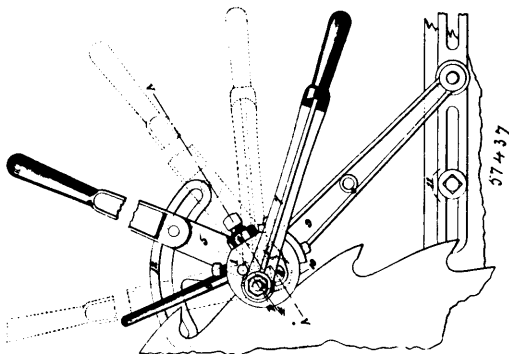

James Harrison Steedman and George Fox Steedman, both of St. Louis, Missouri, U.S.A., 16th September, 1897; 6 years. (Filed 30th August, 1897.)

*Claim.*—In a saw swage wherein the saw tooth is swaged by the rotation of an eccentric die, swaging out the tooth against an anvil the combination of the head 1, having slot 10, the eccentric die 2, the cylindrical anvil 3, clamping screws 4, the lever 5, set screw 6, the clamping lever 7, the adjusting stop 8, the arm 9, the adjustable slide 11, and the adjustable arc 12, as shown and described.

**No. 57,438. Freight Transferring Apparatus.**  
(Appareil à transférer le fret.)

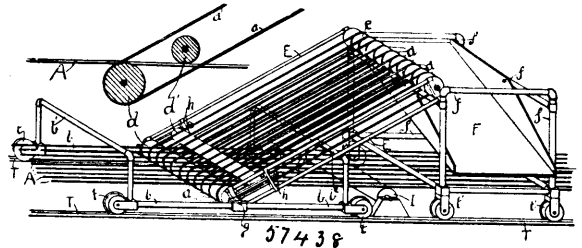

William Leggett McCabe and Charles Herbert Anderson, both of Tacoma, Washington, U.S.A., 16th September, 1897; 6 years. (Filed 17th July, 1897.)

*Claim.*—1st. In a transferring mechanism, the combination with a main conveyer, of an elevating conveyer extending longitudinally above the main conveyer and adapted to be moved longitudinally of said main conveyer and to receive material therefrom, substantially as described. 2nd. In a transferring mechanism, the combination with the main conveyer, of an elevating conveyer extending longitudinally of the main conveyer and mounted so as to be reversed in its longitudinal relation on said main conveyer and to receive material therefrom whereby the same may be conveyed toward either end of the main conveyer, substantially as described. 3rd. In a transferring mechanism, the combination with a main conveyer, of a longitudinally movable support, and an elevating conveyer extending longitudinally of the main conveyer and pivoted to said support so as to be capable of inclination in the direction of either end of the support, substantially as described. 4th. In a transferring mechanism, the combination with a main conveyer composed of a series of belts, of a movable support, an elevating conveyer extending longitudinally of the main conveyer, and composed of a series of belts lying between the belts of the main conveyer and carried by said support so as to be longitudinally movable along the length of the main conveyer, substantially as described. 5th. In a transferring mechanism, the combination with a main conveyer, composed of a travelling belt, an elevating conveyer adapted to receive material therefrom, a driving roll beneath said main conveyer and adapted to drive said elevating conveyer, and a pressure roll located above said main conveyer and adapted to hold the same in frictional contact with the driving roll of the elevating conveyer, substantially as described. 6th. In a transferring mechanism, the combination with a main conveyer, of an elevating conveyer extending longitudinally upward above said main conveyer adapted to receive material therefrom, and a dumping table located above said main conveyer and adapted to receive material from the elevating conveyer and to discharge the same at an angle to said conveyer, substantially as described. 7th. In a transferring mechanism, the combination with two conveyers extending at an angle to each other, of a support movable longitudinally of one of said conveyers, and a dumping table pivoted to said support and adapted to receive material from one conveyer and discharge the same in opposite directions upon the other conveyer, substantially as described. 8th. In a transferring mechanism, the combination with a conveyer, of a longitudinally movable support, a transverse inclined dumping table centrally pivoted on said support and adapted to be tilted in opposite directions to discharge material received from said conveyer upon either side thereof, substantially as described. 9th. In a transferring mechanism, the combination with a main conveyer, of an auxiliary conveyer located at an angle thereto, a reversible frame longitudinally movable over the main conveyer, and a pivoted dumping table carried by said frame, whereby the frame and table may be adjusted to receive material from either conveyer and deliver the same to the other conveyer, substantially as described. 10th. In a transferring mechanism, a portable conveyer composed of a belt, a supporting frame having bearing rolls at opposite ends, idler rolls extending transversely of said frame to support said belt, a driving motor located upon a transverse support carried by said frame work and lying between the upper and lower layers of said belt, a driving wheel located upon a support carried by said frame and over which said belt passes, and means connecting the driving wheel and motor, substantially as described. 11th. In a transferring mechanism, the combination with a main conveyer, of an auxiliary conveyer located at an angle thereto, and a vertically inclined pivoted dumping table supported upon a reversible frame and situated at the junction of said conveyers and adapted to discharge material received from one of said conveyers in opposite directions upon the other conveyer, substantially as described. 12th. In a transferring mechanism, the



combination with a main conveyer, of an auxiliary conveyer extending at an angle therefrom, an elevating conveyer extending longitudinally upward from the main conveyer, and a vertically inclined pivoted dumping table located above the main conveyer to receive material from said elevating conveyer and discharge the same in opposite directions, substantially as described. 13th. In a transferring mechanism, the combination with a travelling conveyer, and a vertically inclined elevating conveyer extending longitudinally above the same and adapted to receive material from the upper surface of said travelling conveyer, a second travelling conveyer located in a plane above said first travelling conveyer, and a vertically inclined chute to receive material from said elevating conveyer and discharge the same upon the upper surface of the second travelling conveyer, substantially as described. 14th. In a transferring mechanism, the combination with a main conveyer, of a supporting carriage adapted to be moved longitudinally thereof, an elevating conveyer extending longitudinally above said main conveyer and centrally pivoted upon said carriage so as to be reversed to face either end thereof, and transverse supports located at opposite ends of said carriage and adapted to support the elevating conveyer when in its inclined position, substantially as described. 15th. In a transferring mechanism, the combination with a conveyer having sheaves at opposite ends, of an endless belt passing over said sheaves in a series of parallel lines, a vertical bearing wheel, and a horizontally disposed transferring wheel around which said belt is carried so as to transfer the belt from the upper portion of one end of one sheave to the lower portion of the opposite end of the other sheave, substantially as described. 16th. In a freight transferring mechanism, the combination with a travelling conveyer composed of rope belts extending two or more floors of a warehouse, an elevating conveyer extending above the same and composed of rope belts interlacing with the belts of the travelling conveyer, and an angled chute located to receive material from the elevating conveyer and deposit it upon the upper portion of the travelling conveyer, substantially as described.

**No. 57,439. Grease-Cup. (Godet à graisse.)**

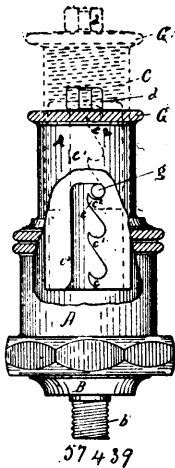

John Francis Lewis, Scranton, Pennsylvania, U.S.A., 16th September, 1897; 6 years. (Filed 7th September, 1897.)

*Claim.*—1st. The herein-described grease-cup consisting of the combination of a receptacle A<sup>1</sup>, a plunger therein actuated by a coiled spring surrounding the stem of said plunger, with the thimble C surrounding said coiled spring and plunger-stem, the sheath E having a threaded connection with the inner sides of said thimble and fitted to the plunger-stem so as to revolve with it but allowing the said stem to slide lengthwise through said sheath, a plunger-stem adapted to turn the said sheath and allow it, the sheath to slide lengthwise of the stem and means for turning the said stem and sheath so as to drive the sheath upward or downward for the purpose of decreasing and increasing the tension of said coiled spring, substantially as shown. 2nd. In a grease-cup, the combination of a spring actuated plunger, the barrel A and thimble C, the said thimble having one of its sides slotted and one of the thus exposed edges provided with a plurality of equidistant hooks adapted to engage, in consecutive order only, with a stub on the barrel A in the process of exhausting grease from the cup, the construction, by reason of interference of the lower edge of said thimble with the plunger, permitting of engagement with the next succeeding hook only after the plunger shall have been forced downward a distance corresponding to that between consecutive hooks, substantially in the manner and for the purposes specified. 3rd. The combination of the plunger-stem D adapted to receive the sheath E, the thimble C inwardly-threaded, the sheath E adapted to be revolved with and by the said plunger-stem and having a threaded portion extending to and adapted to engage with the inwardly-threaded portion of the said thimble, the helical spring d<sup>3</sup>

disposed around the said plunger-stem between the said sheath and plunger F, the plunger F fitted into the receptacle A<sup>1</sup>, and the grease-receptacle A<sup>1</sup>, all arranged for joint operation as and for the purposes shown and described. 4th. In a grease-cup of the kind described, the combination of the barrel A having a narrower upper portion, the thimble C fitted to slide into the said upper portion said thimble having a hole in the top adapted to allow protrusion of the plunger-stem, and also having a slotted side and series of hooks adapted to engage in consecutive order only with a stub on the side of said barrel, the plunger F, and plunger-stem D having a portion d<sup>4</sup> adapted to extend out through the said hole in the top of the said thimble for the purpose of indicating the state and position of parts and contents of the cup, and means for increasing and decreasing the pressure on the plunger, substantially as shown and for the purposes specified.

**No. 57,440. Curry-Comb. (Etrille.)**

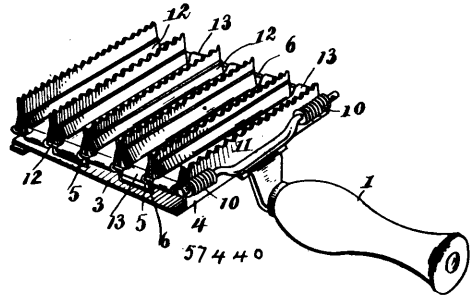

Charles Emile Ballain, Emerson, Iowa, U.S.A., 16th September, 1897; 6 years. (Filed 17th August, 1897.)

*Claim.*—1st. In a curry-comb, the combination with the back carrying a series of parallel toothed-plates or bars, and the handle having a rigid cross-bar, of a cleaner-frame formed from a single wire blank bent to form an open rectangular frame extending around and including all of said toothed bars or plates and having its terminals coiled around said cross-bar and its extremities in engagement with the back, and a series of self-adjusting cleaner-plates slidingly mounted on the cleaner-frame and extending between the toothed bars or plates against which they bear with a spring pressure, substantially as described. 2nd. In a curry-comb, the combination with the back and a handle projecting from one end thereof, of a series of parallel toothed-plates attached rigidly to the back and extending at right angles to the plane of the handle, a cleaner frame extending around the toothed-plates and pivoted at the handle end of the back, a post carried by the cleaner-frame at its swinging end and projecting above the upper side of the back and also formed with a headed end, and a leaf-spring secured to the back and having its free end slotted to straddle said post and exert its tension against the head thereof for the purpose of upholding the cleaner frame, substantially as described.

**No. 57,441. Spraying Attachment for Brooms. (Appareil à arroser pour balais.)**

(Appareil à arroser pour balais.)

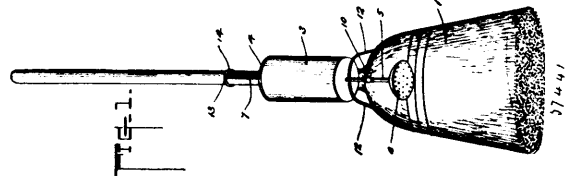

Henry Fred Brockmann, Santa Rosa, California, U.S.A., 16th September, 1897; 6 years. (Filed 10th August, 1897.)

*Claim.*—A broom attachment for the purpose described, consisting of a tank provided with a discharge pipe having a spraying head and a controlling valve, a piston, means for exerting a downward pressure upon the piston to force the fluid contained in the tank through the spraying head, and means for attaching the tank to the broom, substantially as set forth.

**No. 57,442. Spike-puller. (Tire-clou.)**

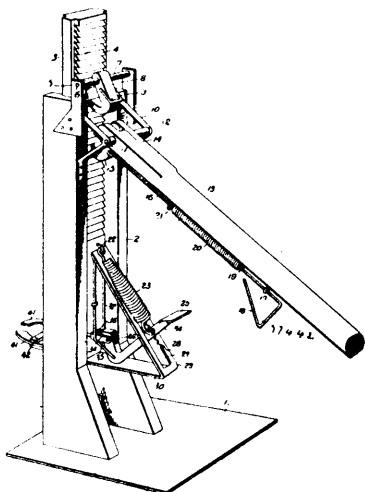

Elmer Ludwick Dale, Waterford, Wisconsin, U.S.A., 16th September, 1897; 6 years. (Filed 20th August, 1897.)

*Claim.*—1st. In a spike-puller, the combination of guides having a toothed slide mounted therein, a pair of spike engaging jaws carried by the lower end of the said slide, and a foot-lever operating said jaws, and a lever having a dog in connection therewith for engaging the toothed slide to elevate the same, substantially as and for the purposes specified. 2nd. A spike-puller comprising a vertically adjustable slide with teeth therein, a lever carrying a dog to engage said teeth, and movable jaws supported at the lower end of said slide to engage a spike, substantially as and for the purposes specified. 3rd. In a spike-puller, the combination of a vertically adjustable slide having teeth therein, an upper dog to engage the said teeth, a lever carrying a spring-actuated dog to raise the slide, a pair of jaws supported at the lower portion of the slide, a spring-actuated foot-operating lever having a pull-rod to close the said jaws, and means for locking the said foot-operating lever, substantially as and for the purposes specified. 4th. In a spike-puller, the combination of a vertically adjustable slide having teeth therein, a gravitating dog engaging the said teeth, a lever having a dog at the outer end thereof to engage the teeth and raise the slide, an operating rod attached to the said dog and supporting in connection with said lever, a spring engaging the said operating rod and the lever, a foot-lever having a spring connected thereto, a slotted plate provided with serrations or teeth with which the said foot-lever is adapted to engage, a pull-rod attached to a portion of the said foot-lever, and a pair of jaws having inwardly extending links to which the said pull-rod is attached, substantially as and for the purposes specified. 5th. In a spike-puller, the combination of a vertically adjustable slide, a spring-actuated lever adjustably secured in connection with the inner lower portion of said slide, movable jaws supported on the outer part of the lower portion of said slide, a pull-rod extending from said foot-lever to the said jaws, an upper gravitating dog to hold the slide in its adjusted position, a lever having a dog in the end thereof to engage the teeth of the slide to raise the latter, and a spring-actuated rod attached to said dog and to the lever, substantially as and for the purposes specified.

**No. 57,443. Rotary Engine. (Machine rotatoire.)**

Charles Abell Ingerham, Wabigoon, Algoma, Ontario, Canada, 16th September, 1897; 6 years. (Filed 26th August, 1897.)

*Claim.*—1st. In a rotary engine, in combination, the end-plates, the shaft, the cylinder-ring suitably secured to the end-plates, and formed with a concentric lower portion and a cam-shaped upper portion, the disc secured to the shaft, and the diametrically-situated wing-pistons fitting in recesses in the disc, means for holding the wing-piston in steam-tight contact with the interior periphery of the cylinder-ring, and suitable inlet and exhaust ports, as and for the purpose specified. 2nd. In a rotary engine, in combination, the end-plates, the shaft, the cylinder-ring suitably secured to the end-plates, and formed with a concentric lower portion and a cam-shaped upper portion, the disc secured to the shaft, and the diametrically-situated wing-pistons fitting in recesses in the disc, means for holding the wing-pistons in steam-tight contact with the interior periphery of the cylinder-ring thereof, and suitable inlet and exhaust ports having passage-ways leading therefrom around the cam-shaped portion of the cylinder-ring to the ends of the concentric portion, as and for the purpose specified. 3rd. In a rotary engine, in combination, the end-plates, the shaft, the cylinder-ring suitably secured to the end-plates, and formed with the concentric lower portion and a cam-shaped upper portion, the disc secured to the shaft, and the diametrically-situated wing-pistons formed in two

parts and fitting in recesses in the disc, cams secured to the bearings of substantially parallel contour to the periphery of the cylinder-

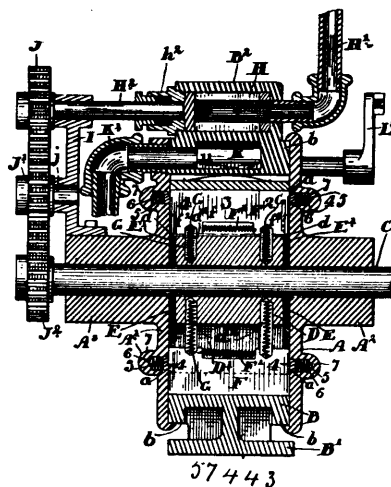

ring, and fitting within circular recesses in the end of the central disc, and suitable inlet and exhaust ports, as and for the purpose specified. 4th. In a rotary engine, in combination, the end-plates, the shaft, the cylinder-ring suitably secured to the end-plates, and formed with the concentric lower portion and a cam-shaped upper portion, the disc secured to the shaft, and the diametrically-situated wing-pistons formed in two parts and fitting in recesses in the disc, cams secured to the bearings of substantially parallel contour to the periphery of the cylinder-ring, and fitting within circular recesses in the end of the central disc, and springs fitting into recesses at the inner side of the radial recesses and into registering recesses in the inner edges of the wing-pistons, and the inlet and exhaust ports, as and for the purpose specified. 5th. In a rotary engine, in combination, the end-plates, the shaft, the cylinder-ring suitably secured to the end-plates, and formed with the concentric lower portion and a cam-shaped upper portion, the disc secured to the shaft, and the diametrically-situated wing-pistons formed in two parts and fitting in recesses in the disc, inner end projections to the two parts, and a spiral spring connecting the end projection of one part to the opposite end projection of the other part, and the inlet and exhaust ports, as and for the purpose specified. 6th. In a rotary engine, in combination, the end-plates, the shaft, the cylindrical ring suitably secured to the end-plates, and formed with a concentric lower portion and a cam-shaped upper portion, the disc secured to the shaft, and the diametrically-situated wing-pistons fitting in recesses in the disc, means for holding the wing-pistons in steam-tight contact with the interior periphery of the cylinder-ring, a recess in the centre periphery of the cam portion, and suitable packing therefor, and inlet and exhaust ports, as and for the purpose specified. 7th. In combination, the end-plates, the shaft, the cylinder-ring suitably secured to the end-plates, and formed with the concentric lower portion and a cam-shaped upper portion, the disc secured to the shaft, and the diametrically-situated wing-pistons fitting in recesses in the disc, the curved passage-ways 10 and 11 in the cam-shaped portion of the periphery of the cylinder-ring, and the controlling valves L and L<sup>1</sup>, with passage-ways l and l<sup>2</sup> and l<sup>1</sup> and l<sup>3</sup> respectively, the passage-ways 9, the rotary cut-off valve H provided with ports h, and means for communicating motion to the stem of the rotary valve, whereby such valve is caused to rotate in unison with the shaft, as and for the purpose specified.

**No. 57,444. Shoe Shank Stiffener.**

(Sous-contre-fort de souliers.)

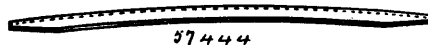

George Ezra Morton Lewis, Truro, Nova Scotia, Canada, 16th September, 1897; 6 years. (Filed 30th August, 1897.)

*Claim.*—1st. A wooden shoe shank-stiffener cut with a longitudinal curve corresponding to the natural longitudinal curve of the foot, substantially as and for the purpose hereinbefore described. 2nd. A shoe shank-stiffener having horizontal and transverse curves formed by cutting knives, and being chamfered on the concave side longitudinally at both edges and both ends, substantially as and for the purpose hereinbefore set forth and described.

**No. 57,445. Gas Stove. (Poêle à gaz.)**

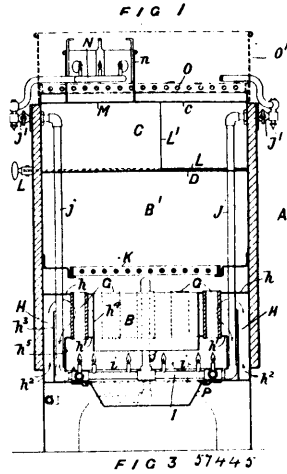

Robert Pringle, Blackheath, Kent, England, 16th September, 1897; 6 years. (Filed 1st September, 1897.)

*Claim.*—1st. The herein described gas stove adapted for cooking purposes and comprising upper and lower roasting spaces, the lower one being surrounded on three sides by an air inlet and heating chamber traversed by vertical flues (preferably of fire-clay) opening through the top and bottom of said chamber, gas burners below the air heating chamber supplied with regeneratively heated gas, a removable bottom forming a basting dish, a grating separating the upper and lower roasting spaces, an oven above traversed by the hot air from the roasting space under the control of a damper, and discharge apertures in the top of the oven for supplying the hot air to burners and heating cooking vessels placed above them, all substantially as specified. 2nd. In the herein described cooking stove the bottom of the roasting chamber made in the form of a basting dish and fitted to slide removably in guides so as to exclude cold air and receive the fat from the roast, as described. 3rd. In the herein described gas roasting stove the doors of the roasting chamber and oven provided with windows and supporting thermometers denoting the temperature within the said chamber, as described. 4th. In the herein described gas cooking stove the roasting chamber divided into an upper and lower chamber by a grating, the lower chamber being surrounded on three sides by an air inlet and heating chamber traversed by vertical flues leading from the combustion chamber beneath to the roasting chamber above, gas burners arranged below the air heating chamber and so placed and shielded as to avoid choking the burners by grease falling thereon, substantially as and for the purpose specified. 5th. In the herein described gas cooking stove the combination with the air heating chamber surrounding the roasting chamber on three sides and traversed by vertical flues, and with gas burners arranged beneath the same as described, of air inlets and baffle plates whereby the air is conducted upwards into the air heating chamber and then downwards therefrom and delivered to the combustion space below the level of the burners, and of a curtain descending from the inner wall of the air heating chamber so as to partially separate the combustion space from the roasting chamber and prevent the flames being blown inwards or disturbed, as specified. 6th. In the herein described gas cooking stove the combination with the apertures by which the hot air is emitted from the roasting chamber and oven, of burners supplied with regeneratively heated gas from the regenerator in one of the flues so that the complete combustion of the gas is maintained by the heated air from the stove, as described. 7th. In the herein described gas cooking stove the ring burners located above the apertures by which the hot air is emitted from the stove, the burners being carried by swinging brackets pivoted beyond the sides of the stove so as to admit of being swung clear of the top of the stove and combined with removable supports for cooking utensils, as described. 8th. In the herein described gas cooking stove provided with ring burners located over the apertures by which the hot air is emitted from the roasting chamber and oven, the burners being connected with the regenerator from which heated gas is supplied to the burners by pipes passing up through the roasting chamber and oven, then out through the side of the casing A, to stop-cocks and pivotal sockets in which the arms carrying the ring burners are pivoted, substantially as shown and described.

**No. 57,446. Process and Apparatus for Cooking by Steam. (Procédé et appareil pour cuire à la vapeur.)**

Hubert Higgins, Cambridge, England, 17th September, 1897; 6 years. (Filed 14th August, 1897.)

*Claim.*—1st. The process of cooking, drying or sterilizing by steam, which consists in using the steam at substantially atmos-

pheric pressure, but at varying degrees of temperature, from 160° C. or upwards, to suit the requirements of the different culinary opera-

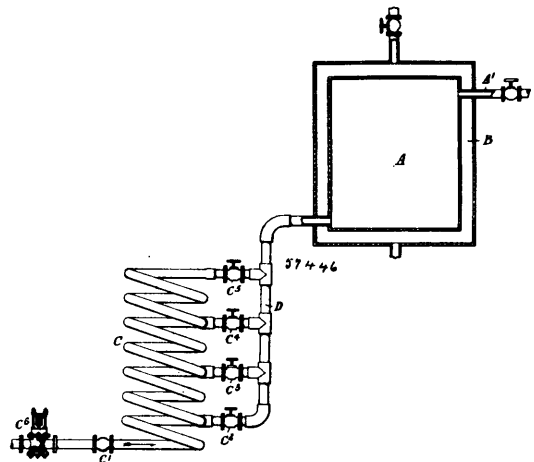

tions, substantially as specified. 2nd. In apparatus for cooking, drying or sterilizing by steam, a chamber A, and a steam supply therefor through pipe D, in combination with a super-heater C, constructed to supply steam at different temperatures to the said chamber A, substantially as and for the purpose specified. 3rd. In apparatus for cooking, drying or sterilizing by steam, a chamber A, and a steam supply therefor through pipe D, in combination with a super-heater C, provided at different points of its length with branches communicating with pipe D, and controlled by a series of valves C<sup>2</sup>, C<sup>3</sup>, C<sup>4</sup>, C<sup>5</sup>, one on each side of said branches, and arranged to supply steam to the said chamber, substantially as and for the purpose specified. 4th. In apparatus for cooking, drying or sterilizing by steam, a chamber A, and a steam supply therefor through pipe D, and steam outlet pipe A<sup>1</sup>, in combination with a super-heater C, provided at different points of its length with branches communicating with pipe D, and controlled by a series of valves C<sup>2</sup>, C<sup>3</sup>, C<sup>4</sup>, C<sup>5</sup>, one on each of said branches, and arranged to supply steam to the said chamber, a jacket B for the said chamber, and means for supplying heated air to the space between the chamber and jacket, substantially as and for the purpose specified. 5th. In apparatus for cooking, drying or sterilizing by steam, a chamber A, and a steam supply therefor through pipe D, in combination with a super-heater C, communicating with pipe D, and so constructed as to supply steam at different temperatures to the said chamber, and a reducing valve C<sup>6</sup> in the supply pipe, substantially as and for the purpose specified.

**No. 57,447. Coin Assorting and Ejecting Apparatus.**

(Appareil à assortir la monnaie.)

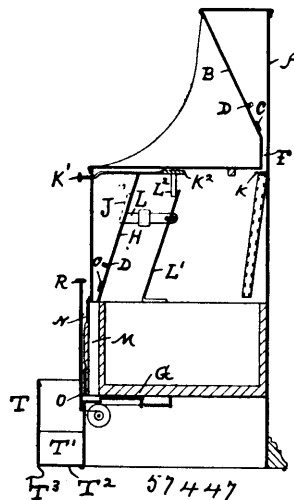

The Globe Cashier (British and Foreign), Limited, 24 Queen Victoria street, assignee of Frank Devonlean Scott, 25 Upper Bedford Place, both in London, England, 17th September, 1897; 6 years. (Filed 30th July, 1897.)

*Claim.*—1st. In a combined coin-assorting and ejecting apparatus, the combination of the upper and lower sorters B and H, the glass panelled compartments F, the compartments J and J at the ends of the apparatus, each having inspection windows, the mechanism operated by press or push knobs for ejecting the coins from the cavities M, the trough T for receiving such coins, and the mechanism for releasing the coins simultaneously from the compartments F, and the compartments I, substantially as herein set forth and as illustrated. 2nd. In a combined coin-assorting and ejecting apparatus, the combination of the upper and lower sorters B and H, the compartments such as F and J, the sliding shutter K and sliding pins L operated by a push knob K<sup>1</sup> for releasing the coins in said compartments F and J simultaneously, the longitudinal bar K<sup>2</sup> connected with said shutter K by cords K<sup>4</sup> passing over pulleys K<sup>5</sup>, the rail K<sup>7</sup> and spring or springs K<sup>6</sup>, the springs L<sup>1</sup> connected with pins L and engaged by the longitudinal bar K<sup>2</sup>, substantially as herein set forth and as illustrated. 3rd. In a combined coin-assorting and ejecting apparatus, the combination of the assorter H, drawer G having cavities M and slots O, the sliding bars Q for pushing the bottom coin out of the cavities, operated by suitable press or push knobs, the wheels similar to Q<sup>3</sup> and Q<sup>4</sup>, and cords Q<sup>2</sup>, the cords R<sup>5</sup> or equivalent means connected with said push or press knobs, and wheels Q<sup>4</sup> and the springs R<sup>6</sup>, substantially as herein set forth and as illustrated. 4th. In a combined coin-assorting and ejecting apparatus, the combination of the cavities M and coin-ejecting mechanism, with the trough T, having receptacle T<sup>1</sup>, a spring-hinged bottom T<sup>2</sup> on said receptacle, and a leg or hook T<sup>3</sup> on said hinged bottom, substantially as and for the purposes herein set forth and as illustrated. 5th. In an apparatus such as described, the combination of the coin-sorters, having vertically and horizontally inclined chutes with the V-shaped coin slots coated with felt or other suitable substance, the sides forming said slots provided with spring hinges capable of keeping the free ends of said sides suitably together, substantially as and for the purposes herein set forth and as illustrated.

**No. 57,448. Umbrella. (Parapluie.)**

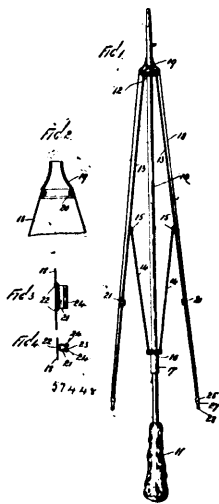

Frank Herbert Mitchell and John Miles, both of New York, State of New York, U.S.A., 17th September, 1897; 6 years. (Filed 12th August, 1897.)

*Claim.*—1st. An umbrella or parasol frame of the usual form provided with a detachable cover, said cover being provided with a bell-shaped ferrule or attachment which is adapted to be passed over the ferrule end of the stick of the umbrella or parasol, and said cover being also provided with tubular clamps which are secured thereto, and which are open on their inner sides, and adapted to receive the ribs of the umbrella or parasol, and said covering being also provided with sockets which are secured thereto, and which are adapted to be connected with the lower ends of said ribs, substantially as shown and described. 2nd. A detachable cover for umbrellas or parasols, said cover being provided with a tubular or bell-shaped attachment which is adapted to be passed over the ferrule end of the stick of the umbrella or parasol, and with tubular clamps which are secured thereto, and which are open on their inner sides and adapted to receive the ribs of the umbrella or parasol, and said cover being also provided at its outer or lower edge with tubular sockets which are adapted to be passed over the ends of the ribs of the umbrella or parasol, substantially as described. 3rd. A detachable cover for umbrellas or parasols, said cover being provided with a tubular bell-shaped attachment as 19, which is adapted to be passed over the ferrule end of the stick of the umbrella or parasol, and with tubular clamps as 21, which are open on their inner sides and adapted to receive the ribs of the umbrella or parasol,

and also with tubular sockets as 25, which are adapted to be connected with the lower ends of the ribs of the umbrella or parasol, substantially as shown and described.

**No. 57,449. Switch Actuating Mechanism for Railways. (Mecanisme d'aiguille de chemin de fer.)**

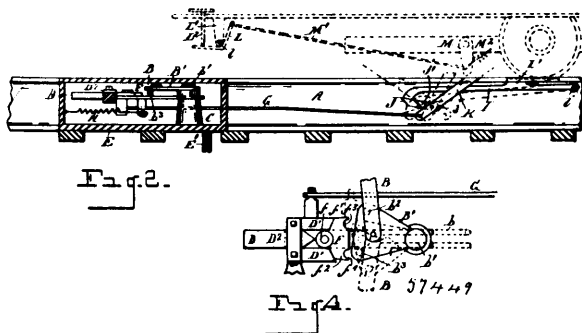

William H. Ranston and Samuel Nash, both of Detroit, Michigan, U.S.A., 17th September, 1897; 6 years. (Filed 27th August, 1897.)

*Claim.*—1st. In a switch-actuating mechanism, the combination with a switch bar, of a reciprocatory dog, and means connected with said switch bar actuated by said dog, for the purpose set forth. 2nd. In a switch actuating mechanism, the combination with a switch bar of a reciprocatory dog, and a movable lever connected with the switch bar actuated by the dog, for the purpose set forth. 3rd. In a switch-actuating mechanism, the combination with a switch bar, of a reciprocatory dog, an oscillatory lever, and means connecting said lever with the switch bar, said lever engagable by the dog to throw the switch bar in the opposite direction from the position occupied, for the purpose set forth. 4th. In a switch-actuating mechanism, the combination with a switch bar, of a lever connected therewith, and means to actuate said lever to throw the switch bar into opposite positions from that occupied, for the purpose set forth. 5th. In a switch-actuating mechanism, the combination with a switch bar, of an oscillatory lever connected therewith, a reciprocatory slide, and a dog carried by said slide to engage said lever, for the purpose set forth. 6th. In a switch-actuating mechanism, the combination with a switch bar, of a lever connected therewith, and a reciprocatory device to engage said lever to move the switch bar into the opposite position from that occupied, for the purpose set forth. 7th. In a switch-actuating mechanism, the combination with a switch bar, of a lever connected therewith, a slide, a dog carried by the slide to actuate said lever, said lever provided with shoulders, one of which is engagable by said dog to throw the switch bar into an opposite position from that occupied, for the purpose set forth. 8th. In a switch-actuating mechanism, the combination with a switch bar, of a reciprocatory slide, an oscillatory dog carried by said slide, means to retract said dog into normal position when the slide is retracted, and a device connected with the switch bar actuated by said dog to throw the switch bar into opposite position from that occupied, for the purpose set forth. 9th. In a switch-actuating mechanism, the combination with a switch bar, of an oscillatory lever connected therewith, a reciprocatory slide, ways in which said slide reciprocates, and an oscillatory dog carried by said slide engagable with said lever to throw the switch bar into opposite position from that occupied, said ways constructed to guide the dog into normal position when the slide is retracted, for the purpose set forth. 10th. In a switch-actuating mechanism, the combination with a switch bar, of a lever connected therewith, a reciprocatory slide, an oscillatory dog carried by the slide to engage said lever, an operating rod connected with said slide to force the slide towards the lever, and means to retract the slide, for the purpose set forth. 11th. In a switch-actuating mechanism, the combination with a switch bar, of a lever connected therewith, a reciprocatory slide provided with means to engage said lever and throw the switch bar into the opposite position from that occupied, a rod connected with said slide, and a lever connected with the opposite end of said rod, said lever engagable by a device carried by a car, for the purpose set forth. 12th. In a switch-actuating mechanism, the combination with a switch bar, mechanism to shift the position of said bar, a rod connected with said mechanism, a lever connected with said rod, a lever provided with a shoulder engagable by a car wheel to throw the first named lever into position, and means carried by a car to engage the first named lever, for the purpose set forth. 13th. In a switch-actuating mechanism, the combination with a switch bar, mechanism to throw the bar into position opposite to that occupied, a rod G, and levers I, J, and K, arranged substantially as and in the manner set forth. 14th. In a switch-actuating mechanism, the combination with a switch bar, of mechanism connected therewith to throw the bar into position opposite to that

occupied, an operating rod connected with said mechanism, and means engagable by a car to actuate said rod, substantially as set forth.

**No. 57,450. Curtain Pole Ornament.**

(Ornement pour batons de rideaux.)

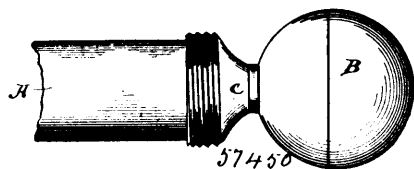

Charles Carpenter Vosburgh, Amsterdam, New York, U.S.A., 17th September, 1897; 6 years. (Filed 30th August, 1897.)

*Claim.*—1st. In combination with a curtain-pole, an exteriorly-threaded cap fitting the pole circumferentially and also transversely at its end, said cap having its bottom fixed directly to the end of the pole by tacks or the like situated at several points outside its centre to obviate independent rotation, an intermediate interiorly-threaded base adapted to be screwed on the threaded cap, and a knob secured to said base, substantially as described. 2nd. The combination with a curtain pole, and an exteriorly-threaded cap fixed thereon by its bottom secured directly to the end of the pole by tacks or the like, an interiorly-threaded base to receive and fit the fixed cap, and an end ornament, said base and ornament having parallel contiguous faces secured together by lips formed in one entering perforations in the other, said lips being upset or clenched, substantially as described.

**No. 57,451. Extension Table. (Table à rallonge.)**

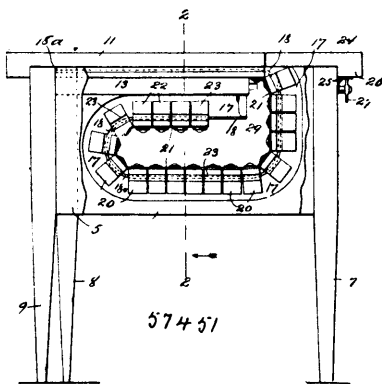

John Pinther, Morris Sauber and Jacob Greenberg, all of New York, State of New York, U.S.A., 17th September, 1897; 6 years. (Filed 1st September, 1897.)

*Claim.*—1st. An extensible table consisting of a main part which is preferably rectangular in form, an extensible part connected therewith at one end thereof, said extensible part being provided with a table-board with the bottom of which is connected stationary bars, said stationary bars being provided with sliding supplemental bars which are connected therewith, and which are also adapted to slide in the sides of the end of the stationary part of the table, and an endless apron connected with the extensible part of the table and supported by said sliding bars, and adapted to move in grooves formed in the inner surfaces of the sides of the stationary part of the table, and said stationary part of the table being provided at its outer end with a hinged supplemental table-board which is adapted to operate in connection with said endless apron, substantially as shown and described. 2nd. An extensible table consisting of a stationary part, an extensible part provided with sliding bars which are connected therewith, and adapted to slide into the stationary part, said sliding part being also provided with a stationary table-board, and said stationary part being provided at the opposite end thereof with a hinged supplemental table-board, and said stationary part being provided in the inner surface of the sides thereof with curved grooves, and an endless apron connected with the stationary part, and adapted to slide into said grooves, substantially as shown and described. 3rd. An extensible table consisting of a stationary part, an extensible part provided with sliding bars which are connected therewith, and adapted to slide into the stationary part, said sliding part being also provided with a stationary table-board, and said stationary part being provided at the opposite end thereof with a hinged supplemental table-board, and said stationary part being provided in the inner surface of the sides thereof with curved

grooves, and an endless apron connected with the stationary part, and adapted to slide into said grooves, said endless apron consisting of transverse strips connected on the under sides thereof by straps or bands, and said strips being provided with end grooves, and the grooves in the sides of the stationary table being provided with metal strips which fit in the grooves in said apron strips, and which are extended also on the top of the stationary part of the table, substantially as shown and described. 4th. An extensible table consisting of a rectangular stationary part, an extensible part provided with a table-board, and bars secured to the bottom thereof, supplemental bars connected with and adapted to slide on said first-named bars, and being also adapted to slide into the stationary part of the table, said stationary part of the table being provided with grooves in the inner surfaces of the sides thereof, which open upwardly, and an endless apron connected with the table-board of the stationary part and adapted to enter said grooves, said stationary part of the table being also provided with a hinged supplemental table-board, substantially as shown and described. 5th. An extensible table consisting of a rectangular stationary part, an extensible part provided with a table-board and bars secured to the bottom thereof, supplemental bars connected with and adapted to slide on said first-named bars, and being also adapted to slide into the stationary part of the table, said stationary part of the table being provided with grooves in the inner surfaces of the sides thereof which open upwardly, and an endless apron connected with the table-board of the extensible part and adapted to enter said grooves, said stationary part of the table being also provided with a hinged supplemental table-board, and means for preventing the separation of the separate parts of the table, and for operating said hinged table-board, substantially as shown and described. 6th. An extension table consisting of two parts, one of which is provided with sides in the surface of each of which is formed a groove which opens upwardly, the other part being provided with an endless apron which is adapted to slide in said groove, substantially as shown and described. 7th. An extension table consisting of two parts, one of which is provided with sides in the surface of each of which is formed a groove which opens upwardly, the other part being provided with an endless apron which is adapted to slide in said groove, and means for preventing the separation of said parts, substantially as shown and described.

**No. 57,452. Fence Machine. (Machine à clôture.)**

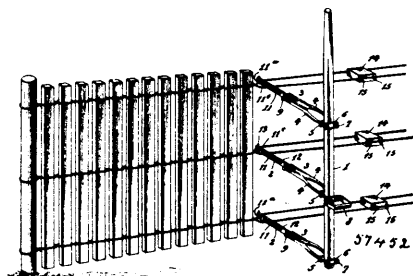

William W. Barker, Pike County, Missouri, U.S.A., 17th September, 1897; 6 years. (Filed 1st September, 1897.)

*Claim.*—1st. A hand fence machine, comprising an operating bar, a series of arms adjustably secured to the operating bar, and twisting bars having pivotal connection with the said arms and provided with a pair of longitudinal slots adapted to receive the wires to be twisted, substantially as and for the purposes set forth. 2nd. A hand fence machine, comprising an operating bar, a series of supporting arms adjustable upon the operating bar, each supporting arm consisting of similar members having offsets intermediate of their ends and having their rear ends reduced and threaded, yoke-plates mounted upon the reduced ends of the members and disposed upon opposite sides of the bar, nuts mounted upon the threaded terminals of the said members for clamping the yoke-plates against the sides of the operating bar, a yoke-plate of one of the supporting arms being formed into a handle substantially as shown, and twister-bars having pivotal connection with the supporting arms and provided with wire-receiving slots, substantially as described. 3rd. A hand fence machine, comprising an operating bar, a series of arms secured to the operating bar, twisting bars having pivotal connection with the said arms and provided with inner and outer longitudinal slots, the outer longitudinal slot extending to the end of the bar and the inner longitudinal slot being longer than the outer one and provided at its inner end with an entrance branch or portion, and a fastening device extending across the outer slot and adapted to retain a wire therein, substantially as described. 4th. In a hand fence machine, the combination with a pair of fence wires, of a twisting bar engaging the wires, means for operating the twisting bar, and a spreader block slidably mounted on the fence wires in advance of the twisting bar, substantially as described. 5th. In a hand fence machine, the combination with a pair of fence wires, of a twisting bar provided with longitudinal slots and having an intervening connecting portion, means for operating the twisting bar,

and a spreader block slidingly mounted on the wires in advance of the twisting bar, and adapted to prevent the wires from binding against the said connecting portion of the twisting bar, substantially as described.

**No. 57,453. Roof Construction. (Toiture.)**

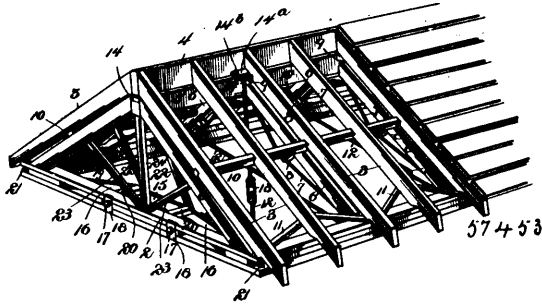

Fred Lee Cook, Ashtabula, Ohio, U.S.A., 17th September, 1897; 6 years. (Filed 1st September, 1897.)

*Claim.*—1st. In a roof, the combination with side plates and a ridge-beam, of continuous or looped tension-braces connected at their extremities to the side plates and extending over the ridge-beam, the side portions of said braces being diagonally disposed, substantially as specified. 2nd. In a roof, the combination with side plates and a ridge-beam, of diagonally disposed tension-braces connecting the side plates with the ridge-beam and disposed in opposite or intersecting planes to brace the structure longitudinally in opposite directions, substantially as specified. 3rd. In a roof, the combination with a plate, of a horizontally disposed strut-brace having struts stepped at their remote ends upon the plate, and tension bolts for adjusting the thrust of said struts, substantially as specified. 4th. In a roof, the combination with a plate, of a horizontally disposed strut-brace having a crown piece, struts arranged at their contiguous ends in contact with the extremities of the crown-piece, and stepped at their remote ends upon the plate, tension-bolts for adjusting the thrust of the struts, and hangers for supporting the intermediate portion of the brace, substantially as specified. 5th. In a roof, the combination with a plate, of a truss-brace arranged in a horizontal position, and having a tensile rod or cable attached at its extremities to the plate and traversing a bridging-block, substantially as specified. 6th. In a roof, the combination of side plates, a ridge-beam, inclined struts connecting said plates with the ridge-beam, diagonally disposed tensile braces in the plane of the struts, and cross-braces connecting the struts, the roof-rafters being adapted to be notched over said cross-pieces, substantially as specified. 7th. In a roof, the combination of side plates, a ridge-beam, inclined struts connecting said parts and provided with truss-braces, cross-braces connecting the struts, rafters seated upon the side plates and notched over the cross-braces, and auxiliary inclined braces extending from intermediate points of the rafters to the lower extremities of the struts, substantially as specified.

**No. 57,454. Printing Telegraph.**

(*Telegraphe imprimant.*)

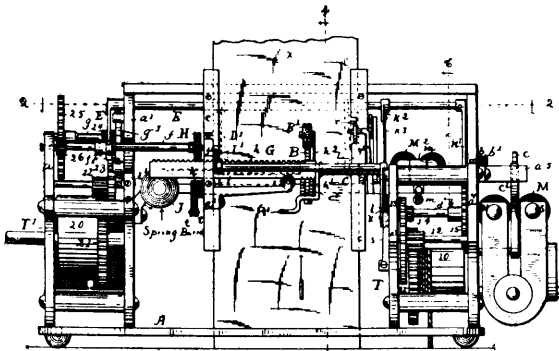

The Consolidated Telegraph Company, New York, assignee of Samuel Van Buren Essick, Yonkers, both in the State of New York, U.S.A., 17th September, 1897; 6 years. (Filed 19th December, 1895.)

*Claim.*—1st. In a printing telegraph receiver, or analogous printing instrument, a type-wheel carried rotatively by a shaft, control-

ling mechanism for determining its forward rotation, a carriage connected to the type-wheel and movable to feed the latter across the face of a stationary sheet of paper, a mechanical motor constituting a power-impelled feeding device, exerting a constant stress tending to propel the carriage forward to advance the type-wheel, and an escapement for controlling said feeding device, and thereby determining the feeding movements of the type-wheel. 2nd. In a printing telegraph receiver, or analogous printing instrument, a type-wheel carried rotatively by a shaft, controlling mechanism for determining its forward rotation, a carriage connected to the type-wheel and movable to feed the latter across the face of a stationary sheet of paper, a retracting device exerting a constant tension against said carriage in the contrary direction to its feed, a power-impelled feeding device exerting a constant tension tending to propel the carriage against and superior to the tension of said retracting device, to feed forward the type-wheel, and an escapement for controlling said feeding device. 3rd. In a printing telegraph receiver, or analogous printing instrument, a type-wheel carried rotatively by a shaft, controlling mechanism for determining its forward rotation, a carriage connected to the type-wheel and movable to feed the latter across the face of a stationary sheet of paper, a power-impelled feeding mechanism, controlled by an escapement, for propelling the carriage forward to advance the type-wheel, mechanism operated by an abnormal rotation of the type-wheel for disconnecting said feeding mechanism from the carriage, and retracting means for returning the feed carriage to its starting point to commence a new line. 4th. In a printing telegraph receiver, or analogous printing instrument, a type-wheel carried rotatively by a shaft, controlling mechanism for determining its forward rotation, a carriage connected to the type-wheel and movable to feed the latter across the face of a stationary sheet of paper, a power-impelled feeding mechanism, controlled by an escapement, for propelling the carriage forward to advance the type-wheel, mechanism operated by an abnormal rotation of the type-wheel for disconnecting said feeding mechanism from the carriage, consisting of a pinion revolving with or proportionately to the type-wheel, a travelling rack-bar advanced by said pinion at each rotation thereof a distance proportioned to the extent of its rotation, and automatically returning to its starting point at each stoppage of the pinion connected to the feeding mechanism and adapted by its extent of movement to disconnect the same from the carriage, and retracting means for returning the carriage to its starting point. 5th. In a printing telegraph receiver, or analogous printing instrument, a type-wheel carried rotatively by a type-wheel shaft geared to a continuously-acting source of power, a paper-holder, a carriage connected to the type-wheel and adapted to feed the latter across the face of a sheet of paper in said paper-holder, geared to a second continuously-acting source of power, escapements for the type-wheel shaft and carriage, a printing platen carried by a printing lever mechanically connected to the second source of power, and mechanical and electrical connections whereby printing is effected in page form. 6th. In a printing telegraph receiver, or analogous printing instrument, a type-wheel, a feeding carriage therefor, and an actuating motor provided with an escapement for operating each, a retractor for moving said carriage backward, feeding mechanism for advancing said carriage line by line, and mechanical connections between the type-wheel and said feed mechanism for disengaging the latter from the carriage at any point in the forward movement, to permit the carriage to be retracted at any part of a line to commence a new line. 7th. In a printing telegraph receiver, or analogous printing instrument, a type-wheel, a feeding carriage therefor positively connected to a power-impelled train of gears through a rack and worm gear, in combination with mechanism for releasing the worm from the rack at any part of its journey, said releasing mechanism consisting of a cam-lever and rock-shaft, and mechanical connections with a power-impelled train of gears, additional means being provided for returning the carriage to its starting point when released. 8th. In a printing telegraph receiver, or analogous printing instrument, of the page type, a type-wheel, a feeding carriage therefor having a rack engaged by a worm connected to a source of power, a retractor connected to the carriage and exerting a tension for restoring it to its starting position, releasing mechanism consisting of a rock-shaft and cam-lever for disconnecting said worm from said rack, a stationary paper-holder, and a line feed mechanism adapted to feed the paper from one line to the next upon the restoration of the carriage. 9th. In a printing telegraph receiver, or analogous printing instrument, a type-wheel, a printing mechanism, a movable carriage, a feeding mechanism therefor, and means for returning the carriage to its starting point from any point on a line to begin a new line, in combination with a line feed for the paper consisting of an electro-magnet, a feeder engaging the paper and actuated by the excitation of the magnet to feed the paper, an electric circuit including said magnet, and a circuit closer for controlling the excitation of said magnet arranged to be operated by the return of said carriage to its starting point upon completing the printing of a line. 10th. In a printing telegraph receiver, or analogous printing instrument, the combination of a type-wheel, a carriage connected to the type-wheel and movable to feed the latter, printing and feeding mechanisms, means for returning the carriage from any point on a line to its starting point to begin a new line, a stationary paper-holder, and a line feed for the paper, the latter consisting of an electro-magnet, a paper-feeder moved by the excitation of said magnet and adapted to engage the paper and feed it in said holder, an electric circuit for



energizing said magnet, and a circuit-closer in said circuit arranged to be operated by impact from said carriage, upon the restoration of the latter to its starting point to commence a new line.

**No. 57,455. Bottle Stopper. (Bouchon du bouteille.)**

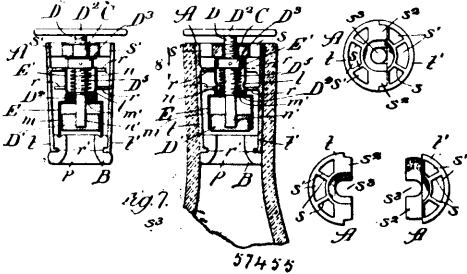

Darius Tennet Phillips, Harry Frank Harvey and Charles Nathan Brisco, all of Chicago, Illinois, U.S.A., 17th September, 1897; 6 years. (Filed 28th August, 1897.)

*Claim.*—1st. In a bottle-stopper, the combination with a liquid discharge valve and its seat, and an outlet passage for liquid leading from the valve seat through the stopper, of a chamber adjacent to the passage and communicating therewith, material, expansive under absorption of liquid, confined in said chamber, and acting when expanded to cause seating of the valve so that the bottle can not be refilled. 2nd. In a bottle-stopper, the combination with a liquid discharge valve and its seat, and an outlet passage for liquid leading from the valve seat through the stopper, of a chamber adjacent to and communicating with the passage, a spring in the chamber for closing the valve, material, expansive under absorption of liquid, confined in said chamber and operating to hold the spring out of action, and acting when expanded to release the spring, whereby the valve is closed and refilling of the bottle is prevented. 3rd. In a bottle-stopper, the combination of a valve seat having an opening through it for the passage of liquid, an outlet passage from said seat through the stopper, a main valve, a stem on said valve with means for screwing it in and out to seat and unseat the main valve, a supplemental valve in the passage, a chamber thereon communicating with the passage through the stopper, a collar on the stem in the chamber, and material, expansive under absorption of liquid, confined in said chamber, and operating when expanded to cause the supplemental valve to be pressed away from the collar and be seated to prevent refilling of the bottle. 4th. In a bottle-stopper, the combination of a seat B, main valve D<sup>1</sup>, main valve stem D, handle D<sup>2</sup> on the stem, a threaded bearing for the stem at the mouth of the stopper through which the stem may be screwed to seat and unseat the valve D<sup>1</sup>, a collar D<sup>3</sup> on the stem, a supplemental valve E capable of moving past the valve D<sup>1</sup> and of seating to close the passage through the stopper, a chamber E<sup>1</sup> at the supplemental valve surrounding the collar D<sup>3</sup> and in open communication with the passage through the stopper, and material, expansive under absorption of liquid, confined in said chamber, and operating when expanded to cause seating of the supplemental valve and prevent refilling of the bottle. 5th. In a bottle-stopper, the combination of a valve seat having an opening through it for the passage of liquid, an outlet passage from said seat through the stopper, a main valve, a stem on said valve with means for screwing it in and out to seat and unseat the main valve, a supplemental valve in the passage, a chamber thereon communicating with the passage through the stopper, a collar on the stem in the chamber, baffles in the passage operating to prevent tampering with the supplemental valve, and material, expansive under absorption of liquid, confined in said chamber, and operating when expanded to cause the supplemental valve to be pressed away from the collar and to be seated to prevent refilling of the bottle. 6th. In a bottle-stopper, the combination of a shell formed of separate members relatively adjustable to fit bottle necks of different sizes, a valve seat at the inner end of the stopper, an outlet for liquid leading from the valve seat through the stopper, a chamber adjacent to and communicating with said passage, a valve at said seat, and material, expansive under absorption of liquid, confined in said chamber, and acting when expanded to cause seating of the valve.

**No. 57,456. Bed Slat. (Planche de couchette.)**

John Rennison, assignee of Guy Mafera, both of Boston, Mass., U.S.A., 17th September, 1897; 6 years. (Filed 31st August, 1897.)

*Claim.*—A foundation cross-piece, or slat composed of a strip of metal set edgewise and formed into an oblong frame, braces or parts

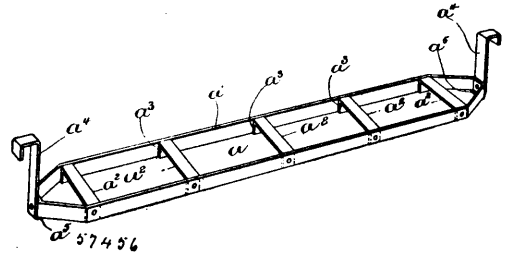

joining the side bars of the frame, and hooks fastened to the ends of the frame and adapted to take over the side rails of a bedstead.

**No. 57,457. Bicycle. (Bicycle.)**

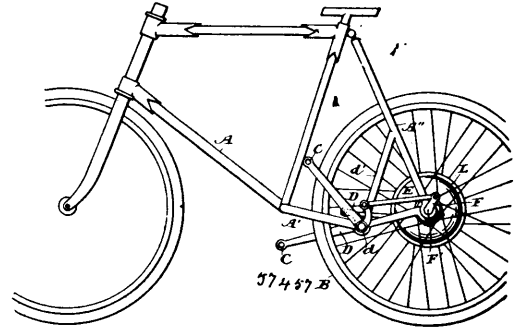

Wilber J. Pine, Oshkosh, Wisconsin, U.S.A., 17th September, 1897; 6 years. (Filed 14th June, 1897.)

*Claim.*—1st. In a bicycle, the combination with a suitable frame, of an axle carrying a master gear, a smaller gear wheel rigidly attached to the hub, sleeves secured to the frame of the bicycle on each side, interior of the hub, one of said sleeves having a projecting arm upon which intermediate gear wheels are pivotally mounted so as to communicate motion from said master gear wheel to the hub gear, the opposite sleeve carrying a fork to engage and slide on the projecting arm and uphold the intermediate gears, substantially as shown. 2nd. In a bicycle, the combination with a suitable frame, of an axle carrying a master gear, a smaller gear rigidly attached to the hub of the bicycle driving wheel, sleeves secured to the frame of the bicycle upon each side, extending into the hub, one of said sleeves having a projecting arm with intermediate gear wheels pivotally mounted thereon, and so arranged as to communicate motion from the master gear to the hub gear, pins carried by said arm, and a bifurcated supporting plate integral with the opposite sleeve, the legs of which support said pins, and a yoke on the pins to form a bearing for the intermediate gear shaft, substantially as described. 3rd. In a bicycle, the combination with a suitable frame, of an axle carrying a straight faced master gear, a smaller gear wheel rigidly attached to the hub, sleeves interior of the hub and secured to the frame of the bicycle on each side, one of said sleeves having a projecting arm upon which intermediate gear wheels are pivotally mounted so as to communicate motion from said master gear to the hub gear, a bifurcated plate integral with the opposite sleeve, the legs of which support pins attached to the opposite sleeve arm, said bifurcated plate being movable laterally upon said pins, and a yoke mounted upon said pins to support the bearing for the intermediate gear shaft, substantially as shown. 4th. In a bicycle, the combination with a suitable frame, of an axle carrying a gear wheel, a hub also provided with a gear wheel, independent sleeves also mounted in the said frame and extending within the hub, means for supporting the inner ends of said sleeves, the construction being such that the sleeves are free to slide with relation to each other, and intermediate gears mounted on bearings carried by the sleeves for communicating movement from the said gear to the hub gear, substantially as described. 5th. In a bicycle, the combination with a suitable frame, of an axle carrying a gear wheel, a hub also carrying a gear wheel, independent sleeves mounted in the said frame and extending within the hub, means for supporting the inner ends of said sleeves so that they are free to slide with relation to each other, intermediate gears mounted on bearings carried by the sleeves for connecting the axle gear with the hub gear, and bearings interposed between the hub and the said sleeves and between the sleeves and the axle, the said bearings being so constructed with relation to the axle that all tendency of the sleeves to move laterally thereon is prevented, substantially as described. 6th. In a bicycle, the combination with a suitable frame,

of an axle carrying a gear wheel, independent hubs upon each side of the wheel, one of said hubs being provided with a gear wheel, independent sleeves mounted in the said frame, and extending within the hub, means for supporting the inner ends of the said sleeves so that they are free to slide with relation to each other, intermediate gears mounted on bearings carried by the sleeves, for connecting the axle gear with the hub gear, a casing interposed between and mounted upon the independent hubs for enclosing the gearing, and bearings interposed between the hubs, and the said sleeves and between the sleeves and the axle, the said bearings being so constructed with relation to the axle that all tendency of the sleeves to move laterally thereon is prevented, and the casing is also free from all lateral strains, substantially as described.

**No. 57,458. Bicycle Propeller and Brake.**  
(*Propulseur et frein de bicycles.*)

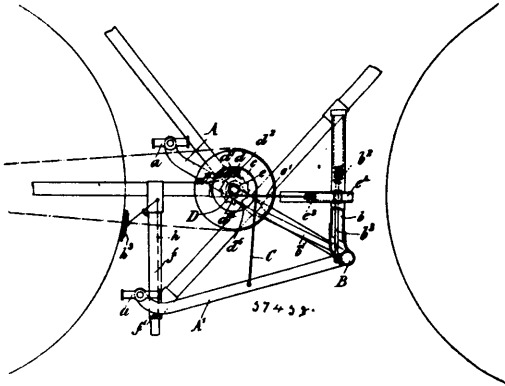

William George Hurst, New Brighton, Chester, England, 6th September, 1897; 6 years. (Filed 3rd August, 1897.)

*Claim.*—1st. In mechanism for propelling cycles and like vehicles, the combination of the levers A and A<sup>1</sup> which are caused to rock on fulcrums B by the feet of the rider pressing on the pedals a<sup>1</sup>, and which are lifted by the springs b<sup>2</sup>, the cord or chains C, the disc c, the pawl d, the ratchet wheel d<sup>4</sup>, the spindle D, the disc e, the cords or chains e<sup>1</sup>, and the spring e<sup>3</sup>, substantially as described and shown. 2nd. In mechanism for propelling cycles and like vehicles, the combination of the levers A and A<sup>1</sup> which are caused to rock on fulcrums B by the feet of the rider pressing on the pedal a and which are lifted by the springs b<sup>2</sup>, the cords or chains C, the disc c, the pawl d, normally lifted clear of the ratchet wheel teeth by means of the band or leaf spring d<sup>3</sup>, the ratchet wheel d<sup>4</sup>, the spindle D, the disc e, the cords or chains e<sup>1</sup> and the spring e<sup>3</sup>, substantially as described and shown. 3rd. In mechanism for propelling cycles and like vehicles, the device for, normally lifting the pawl d clear of the ratchet wheel teeth, consisting essentially of the band or leaf spring d<sup>3</sup>, the link d<sup>2</sup>, and the pawl d, arranged and operating substantially as described and shown. 4th. In combination with mechanism for driving cycles, the brake operating device consisting essentially of the fulcrumed lever h<sup>1</sup> attached to the brake rod h, the ends of which lever are normally rocked alternately by the pressure of the pedals on the levers A A<sup>1</sup>, but upon the levers A A<sup>1</sup>, being simultaneously depressed, the lever h<sup>1</sup> is prevented from rocking and being forced downwards pulls down the brake operating rod h and applies the brake, substantially as shown and described. 5th. For use with mechanism for propelling cycles and like vehicles the combination of the brake rod h, the double ended rocking lever h<sup>1</sup>, the spring g<sup>1</sup>, and the brake h<sup>3</sup>, substantially as described and shown. 6th. For use with mechanism for propelling cycles and like vehicles, the device for increasing the leverage consisting essentially of the slotted end a<sup>2</sup> of the lever A, the block a<sup>1</sup>, and the spring lever pawl a<sup>4</sup> connected to the pedal a in such manner that the inclination of the pedal in one direction allows the pedals to slide so as to vary the leverage substantially as described and shown.

**No. 57,459. Combination Lock for Bicycles.**  
(*Serrure de bicycles.*)

Marshall N. Frederick, Canton, Ohio, U.S.A., 17th September, 1897; 6 years. (Filed 3rd August, 1897.)

*Claim.*—1st. The combination of the saddle, a lock base connected thereto, and provided with a detachable cover, a sliding lock bar attached to the lock plate and provided with a recessed head, a series of tumblers provided with apertures, and screws or pins located in a given number of apertures and the locking spindle provided with annular grooves, a counting disc provided with notches upon its periphery, a spring to engage the notches, a d and operating knob, secured to the locking spindle, substantially as and for the purpose specified. 2nd. The combination of a saddle, a lock base connected thereto, a case or cover provided with a flange, a counting

disc provided with notches upon its periphery, a spring to temporarily engage the notches in the counting disc, a series of tumblers

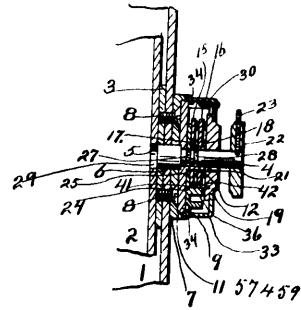

spaced with washers, a hollow post or thimble secured to the lock base, a locking bar located upon the lock base and provided with the elongated opening having a tongue provided with a concaved end, and a locking spindle provided with annular grooves, substantially as and for the purpose specified. 3rd. In a bicycle lock, the combination of a steering head having attached thereto a re-inforcing plate, a saddle connected to the head and to the re-inforcing plate, a lock base provided with the post or thimble having the slot 14, a sliding locking bar provided with a tongue, a longitudinally moving locking spindle provided with annular grooves, a series of tumblers located upon the hollow post or thimble and spaced by suitable washers, a counting disc and means for holding said counting disc against temporary rotation, a cover or case, and an operating knob, substantially as and for the purpose specified. 4th. In a bicycle lock, the combination of a steering head and a steering post located therein and provided with an aperture or apertures such as 29, a locking spindle provided with a series of tumblers having screws or pins, a master notch formed in each tumbler, a sliding or vibrating locking bar provided with a head, means for automatically moving the sliding bar out of engagement with the locking spindle, a counting disc provided with a screw or pin and with apertures, means for temporarily holding the counting disc against rotation and an operating knob, substantially as and for the purpose specified. 5th. The combination of a steering head and a steering post located therein, an aperture formed in the steering post and in the head, a reciprocating locking spindle provided with an operating knob, a counting disc mounted on the spindle and revolving therewith, a series of tumblers provided with master notches, a sliding locking bar, a case or cover provided with a flange, said locking bar extended to engage the flange and lock the cover, substantially as and for the purpose specified. 6th. The combination of a steering head, a steering post located therein, a saddle having connected thereto a lock base, said lock base provided with a tumbler, a reciprocating locking spindle to engage the steering post and provided with an operating knob, and means for locking the steering post against auxiliary rotation by means of the spindle, substantially as and for the purpose specified.

**No. 57,460. Bicycle Brake.** (*Frein de bicycles.*)

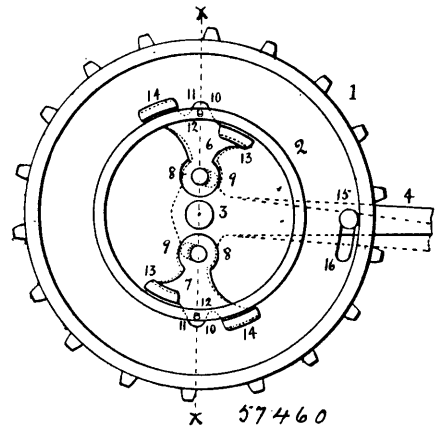

John A. Caldwell, Vancouver, British Columbia, Canada, 17th September, 1897; 6 years. (Filed 10th August, 1897.)

*Claim.*—1st. In a bicycle-brake, the combination of a sprocket-wheel, a ring or rim rigidly supported by the hanger of said sprocket-wheel, a crank and clutches movably attached to said crank and adapted to engage the opposite sides of said ring or rim, substan-

tially as and for the purposes specified. 2nd. In a bicycle-brake, the combination of a sprocket-wheel supported by a hanger, a ring or rim rigidly attached to said hanger, a crank and clutches movably attached to said crank and having annularly disposed lugs on their outer ends to engage opposite sides of the said ring or rim, substantially as and for the purposes specified. 3rd. In a bicycle-brake, the combination of a sprocket-wheel having a suitable supporting hanger, a crank, a ring or rim and clutches engaging the said ring or rim and operated by the back-pedaling movement or pressure on the crank, substantially as and for the purposes specified. 4th. In a brake for a bicycle, the combination of a sprocket-wheel with slots therein and having a suitable hanger, a ring or rim rigidly secured to the said hanger, a crank having a pin extending therefrom through the outer slot in the said sprocket-wheel, and clutches attached to said crank and adapted to engage the said ring or rim, substantially as and for the purposes specified. 5th. In a bicycle-brake, the combination of a sprocket-wheel with slots therein and having a suitable hanger, a ring or rim secured to the said hanger, a crank having a pin extending through the outer slot in the said sprocket-wheel, clutches having their ends attached to the crank by screws or pins which extend through the inner slots in the sprocket, and the said clutches having outer ears which are pivotally fixed to the sprocket-wheel by pins 11, and oppositely disposed annularly positioned lugs 13 and 14 to engage the outer and inner portions of the ring or rim 2, substantially as and for the purposes hereinbefore set forth.

**No. 57,461. Armour for Pneumatic Tires.**

(*Armure pour bandages pneumatiques.*)

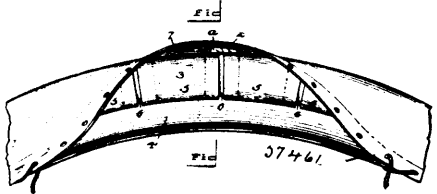

George Seely Engle, Aberdeen, South Dakota, U.S.A., 17th September, 1897; 6 years. (Filed 10th August, 1897.)

*Claim.*—1st. An armour for pneumatic tires, consisting of a flexible strip, main plates secured thereto and curved in the direction of their width and spaced apart, and auxiliary plates secured to said strip between the spaces and under the ends of the main plates, substantially as set forth. 2nd. The combination with the inner tube and outer tube or covering of a pneumatic tire, the said outer tube or covering being provided with pockets, and plates located and held in said pockets, of a strip of flexible material interposed between the inner and outer tubes, main plates secured to said strip and curved in the direction of their width and spaced apart, and auxiliary plates secured to said strip between the spaces and under the ends of the main plates, substantially as set forth.

**No. 57,462. Bicycle Fork Balance.**

(*Montant à balance de bicy cles.*)

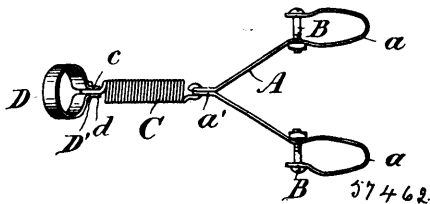

Horace Walter Chamberlin, Ottawa, Ontario, Canada, 17th September, 1897; 6 years. (Filed 13th August, 1897.)

*Claim.*—1st. In a bicycle fork balance, the combination of a yoke having spring clips at its ends adapted to be firmly secured upon the tines of the fork and having rearwardly sloping arms or shanks running to a central point, a coiled spring having one end secured to the central point of said yoke and a spring clip adapted to be firmly attached to the lower frame bar of the bicycle and to which the other end of said spring is secured, substantially as set forth. 2nd. The combination with the lower frame bar and the fork of the bicycle, of a spring clip adapted to be firmly secured to said lower bar, a coiled spring secured to said clip at one end and a yoke having its ends firmly clipped to the tines of said fork and its shanks or arms sloping rearwardly to a central point which is engaged by the other end of said spring, substantially as set forth.

**No. 57,463. Combination Bicycle. (Bicycle.)**

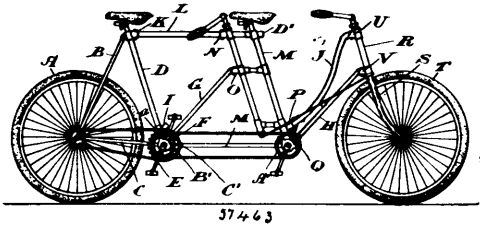

David Creighton, Toronto, Ontario, Canada, 17th September, 1897; 6 years. (Filed 14th August, 1897.)

*Claim.*—1st. In a frame for a combination bicycle, the combination with a rear frame provided with two lower sockets for the rear ends of the bars of a drop frame, or the lower bar of a diamond frame, and an upper socket for the rear end of the upper bar of a diamond frame, of a head provided with two sockets for the forward ends of the bars of either a diamond or drop frame, substantially as and for the purpose specified. 2nd. In a frame for a combination bicycle, the rear frame provided with the seat standard D, having sockets K, I, F, formed thereon in combination with the head R, having sockets U and V formed thereon, and the bars L and G, detachably connected to the sockets K, F, and U, V, substantially as and for the purpose specified. 3rd. In a frame for a combination bicycle, the rear frame provided with the seat standard D, having sockets K, F, F', formed thereon in combination with the head R, having sockets U and V, formed thereon, and two bars detachably connected to two of the sockets K, I, and F, and to the sockets U and V, substantially as and for the purpose specified. 4th. In a frame for a combination bicycle, the combination of the rear fork B, chain stays C, and seat standard D, suitably connected, the sockets K, F, C', formed on the seat standard D, the central frame M, having a part detachably connected to the socket C', the sockets O, N, P and Q, formed on the said frame, the head R, the sockets U and V formed thereon, the bars L and G, detachably connected to the sockets K, F, and N, O, and the bars J and H, detachably connected to the sockets P, Q and V, U, substantially as and for the purpose specified. 5th. In a frame for a combination bicycle, the combination of the rear fork B, chain stays C, and seat standard D, suitably connected, the sockets K, I, F, C', formed on the seat standard D, the central frame M, having a part detachably connected to the socket C', the sockets O, N, P and Q, formed on the said frame, the head R, the sockets U and V formed thereon, the bars L and G, detachably connected to the sockets K, F and N, O, and the bars J and H, detachably connected to the sockets P, Q, and V, U, substantially as and for the purpose specified. 6th. In a frame for a combination bicycle, the combination of the rear fork B, chain stays C, and seat standard D, suitably connected, the sockets K, I, F, C', formed on the seat standard D, the central frame M, having a part detachably connected to the socket C', the sockets O, N, P and Q, formed on the said frame, the head R, the sockets U and V, formed thereon, the bars L and G, detachably connected to the sockets K, F and N, O, and the bars J and H, detachably connected to the sockets P, Q and O, U, the rear wheel A, journaled on the frame comprising the seat standard D, rear fork B, and chain stays C, the front fork S, having its stem journaled within the head R, the front wheel T, journaled on the fork S, handle bars connected to the said fork stem and to the frame M, saddles supported by the seat standard D and the frame M, and suitable driving gear for each rider adapted to drive the rear wheel of the machine substantially as and for the purpose specified.

**No. 57,464. Valve for Pneumatic Tube, &c.**

(*Soupape pour bandages pneumatiques, etc.*)

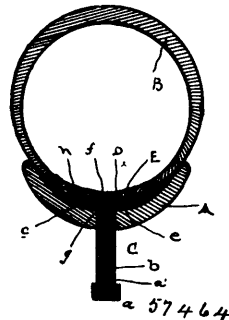

John C. MacSpadden, St. Joseph, Missouri, U.S.A., 1 September, 1897; 6 years. (Filed 16th August, 1897.)

*Claim.*—1st. As an improved article of manufacture, a repair-valve comprising an inflation-tube having an inner portion *b* of rubber provided with exterior threads, and an outer casing *a*, of metal receiving the portion *b*, and having interior threads engaging the threads of the portion *b*, the base *c* formed integral with the rubber portions *b*, and adapted to be connected by rubber cement or the like to the outside of an inflatable device, a check-valve of thin rubber or other material similarly connected to the inner side of the base, and a cap connected by threads to the metallic portion of the inflation-tube. 2nd. The combination of the inflatable tube or other inflatable device having an opening, an inflation-tube having the base arranged on the outer side of the inflatable tube over the opening therein, and secured to said outer side of the tube by rubber cement or the like, and the check or non-return valve of thin rubber or other material secured to the inner side of the base of the inflation tube and interposed between said base and the inflatable device, and adapted to open to permit air to pass from the inflation tube to the interior of the inflatable-tube, and also adapted to check the escape of such air from the inflatable-tube, substantially as specified. 3rd. The combination of the inflatable-tube or other inflatable device, having an opening, a repair-valve comprising an inflation-tube having the base connected by rubber cement or the like to the outer side of the inflatable device, and with or without, as shown in fig. 7, the flat check or non-return valve of sheet rubber or other suitable material connected to the inner side of the inflation-tube base, and adapted to check the escape of air through said tube, substantially as specified.

**No. 57,465. Rubber Tire Fastener.**  
(*Attache pour bandages de caoutchouc.*)

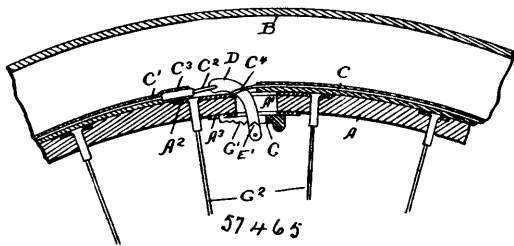

Henry G. Sweeney, Chicago, Illinois, U.S.A., 17th September, 1897; 6 years. (Filed 18th August, 1897.)

*Claim.*—1st. The combination with the tire sheath and its attaching wire, of a curved tightener adapted to be drawn through the rim, said tightener being flexibly attached to one end of the wire, and having a sliding attachment to the other end of the wire, substantially as specified. 2nd. The combination with the tire sheath, of a wire *C* doubled upon itself and attached to both edges of the sheath, and a curved tightener adapted to be drawn through the rim, said tightener being flexibly attached to one end of the doubled wire, and having a sliding attachment to the other end, substantially as specified. 3rd. The combination with a sheath holding wire, of a curved tightener *D* adapted to be drawn through the rim in tightening the wire, and a keeper engaging said tightener and acting to retain the tension, substantially as specified.

**No. 57,466. Bicycle Tire.** (*Bandage de bicycles.*)

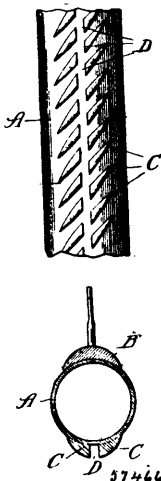

George Washington Dorr, Chicago, Illinois, U.S.A., 17th September, 1897; 6 years. (Filed 25th August, 1897.)

*Claim.*—1st. A tire for bicycle or other wheels provided with lugs, ridges or projections around its external periphery divided by a longitudinal circumferential groove. 2nd. A tire for bicycle or other wheels provided with lugs, ridges or projections around its external periphery divided by a longitudinal circumferential groove and arranged at an angle which presents a portion of the lug, ridge or projection first to the ground, whereby a part of one is coming into contact as a part of another is passing out of contact with the ground. 3rd. A tire for bicycle or other wheels provided with lugs, ridges or projections around its external periphery having uninterrupted air passages between them.

**No. 57,467. Locking Device for Cycles, etc.**  
(*Serrure pour cycles, etc.*)

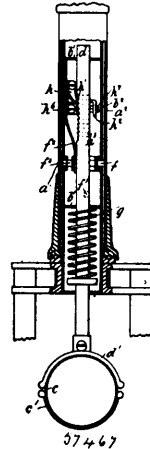

Frank Villiers Stead, London, England, 17th September, 1897; 6 years. (Filed 27th August, 1897.)

*Claim.*—A cycle or other vehicle lock adapted to act on the steering wheel of a cycle or the like, and characterized by the application to the steering fork-tube of a guided squared rod carrying a tire-lock or adapted to apply a brake-block to the tire, a sprig detent, serving, until released by the cyclist, to hold the rod out of action but in position for actuation, a spring, serving, when the rod is released from the detent, to depress the rod and to apply the tire-lock or brake-block to the wheel-tire, and a spring pawl, serving, until itself released by the cyclist by the proper key serving to unlock the device, to keep the rod depressed and the tire-lock or brake-block applied to the wheel-tire, as set forth.

**No. 57,468. Pneumatic Wheel.** (*Roue pneumatique.*)

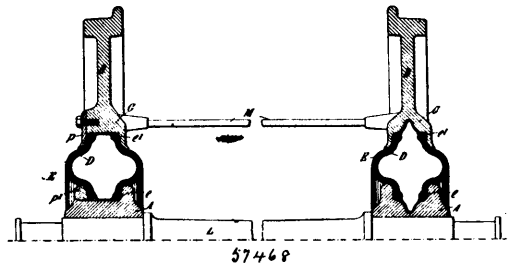

Charles K. Welch, Coventry, Warwick, England, 17th September, 1897; 6 years. (Filed 28th August, 1897.)

*Claim.*—1st. In a wheel, an annular pneumatic cushion formed by an air chamber enclosed between two rigid flanged concentric rings, and two flexible side rings, the inner edges of the latter being inextensible and the outer edges incompressible, and said edges being enclosed by the flanges of the rigid rings, substantially as described. 2nd. The combination with the flexible side rings, of the outer flanged ring constructed with a shoulder or shoulders forming a seat or seats for the incompressible edges being placed eccentric to the flanges of the outer rigid ring to allow of the withdrawal of the said incompressible edges through the inturned flanges of the rigid ring, substantially as described. 3rd. The flexible side rings each having an incompressible core in its outer edges and an inextensible core in its inner edge, substantially as and for the purposes specified. 4th. The flexible rings each constructed of two or more series of closely packed threads, arranged to cross each other at an angle and having wire or equivalent cores in its edges, substantially as described. 5th. A

wheel having the outer edges of the flexible side rings reinforced by cords or an equivalent thereof shaped to form circumferential hooks, and the outer rigid ring formed with corresponding inwardly turned edges or circumferential hooks to engage with the edges of the flexible rings, substantially as and for the purposes specified. 6th. The combination with the grooved outer rigid ring, of a filling for the grooves to keep the incompressible cores of the flexible rings concentric with the flanges of the rigid ring, substantially as described. 7th. The combination with a pair of tramcar wheels each having an annular pneumatic cushion between the hub and the rim, of a tubular or other rigid connection between the outer rigid rings or rims to maintain a constant gauge, substantially as described. 8th. A wheel constructed with an annular pneumatic cushion between the hub and the rim, substantially as described.

**No. 57,469. Bicycle Saddle. (Selle de bicycles.)**

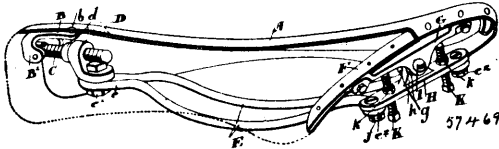

Allan William Taylor, Mt. Elgin, and Willoughby Moffat, Hamilton, both in Ontario, Canada, 17th September, 1897; 6 years. (Filed 4th September, 1897.)

*Claim.*—1st. In a saddle, in combination, a seat, the pivotal connection at the forward end thereof secured underneath the pommel a spring reach connected to the front pivot, the back plate and the longitudinal hinge in the centre of the back plate connecting it to the rear end of the reach, as and for the purpose specified. 2nd. In a saddle, in combination, a seat, the longitudinal bolt at the end thereof secured underneath the pommel, a double spring reach connected to the free end of the bolt and having flaring rear ends, the bottom plate of the saddle provided with depending jaws, the plate connecting the rear ends of the reach and provided with an upwardly extending lug and a bolt arranged to extend through the jaws and lugs, longitudinally in the same vertical plane as the front bolt of the saddle, as and for the purpose specified. 3rd. In a saddle, in combination, a seat, the longitudinal bolt at the forward end thereof, secured underneath the pommel, a double spring reach connected to front end of the bolt and having flaring rear ends, the bottom plate of the saddle provided with depending jaws, the plate connecting the rear ends of the reach and provided with an upwardly extending lug, a bolt arranged to extend through the jaws and lugs longitudinally in the same vertical plane as the front bolt of the saddle, and set screws extending through the connecting plate of the reach on each side of the central lug and designed to limit the rocking movement of the saddle, as and for the purpose specified.

**No. 57,470. Bicycle Gear. (Engrenage de bicycles.)**

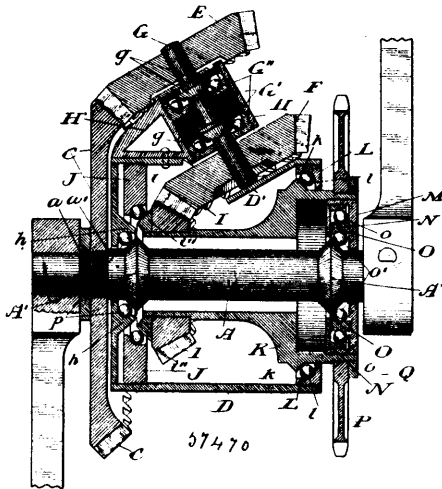

George Thomas Martin, Smith's Falls, Ontario, Canada, 17th September, 1897; 6 years. (Filed 31st August, 1897.)

*Claim.*—1st. In a device of the class specified, the combination with the pedal shaft, of a sprocket-chain wheel mounted independently of the pedal shaft, but deriving motion therefrom by a series of gear wheels, substantially as specified. 2nd. In a device of the class specified, the combination with the pedal shaft, of a hollow mandrel sleeved thereon, a sprocket chain wheel mounted on the

hollow mandrel, and a series of gear wheels intermediate between the hollow mandrel and the pedal shaft for conveying motion from the pedal shaft to the sprocket-chain wheel, substantially as specified. 3rd. In a device of the class specified, the combination with the pedal shaft A, of the bevel gear wheel C, secured to the pedal shaft, the bevel gear wheel E, meshing with the gear wheel C, and carried on one end of the shaft G which is suitably journaled, the bevel gear wheel F, carried on the other end of the shaft G, the bevel gear wheel I, meshing with the bevel gear wheel F, and secured to the hollow mandrel K, the hollow mandrel K, sleeved on the pedal shaft A, and the sprocket-chain wheel P mounted on and secured to the hollow mandrel, substantially as specified. 4th. In a device of the class specified, the combination with the pedal shaft A, journaled on ball bearings within the housing D, of the bevel gear-wheel E, meshing with the bevel gear wheel C, and carried on the shaft G journaled on ball bearings within the bearing box H, which is secured to the housing D, the bevel gear wheel F, carried on the other end of the shaft C, and operating through an opening cut in the housing D, the bevel gear wheel I, meshing with the bevel gear wheel F, secured to the hollow mandrel K, and provided with ball bearings, the hollow mandrel K, provided with ball bearings and sleeved on and secured to the hollow mandrel, substantially as specified. 5th. In a device of the class specified, the combination with the pedal shaft A, suitably journaled on ball bearings within the housing D, of the hollow mandrel K, sleeved on the pedal shaft and provided with ball bearings, the race-ways for the balls being formed by the shoulder i, on the bevel gear wheel I, fixed to the mandrel K, and the grooved ring J, screwed within the housing, by the shoulder k, formed in the hollow mandrel K, and the grooved ring L, screwed within the housing D, and by the ball bearing cup M, screwed within the mandrel, the shouldered ring N, screwed within the cup, the cone A', on the pedal shaft A, and the grooved ring-diaphragm O, separating the balls, the sprocket-chain wheel P, and a series of gear wheels intermediate between the hollow mandrel and the pedal shaft, substantially as described and for the purposes specified. 6th. In a device of the class specified, the combination with the pedal shaft A, suitably journaled, of the hollow mandrel K, sleeved on the pedal shaft A, and provided with ball bearings, comprising the ball bearing cup M, screwed within the mandrel K, the shouldered ring N, secured within the cup M, the cone A', on the pedal shaft A, and the grooved ring-diaphragm O, separating the balls, substantially as specified.

**No. 57,471. Attachments to Bicycles. (Attache de bicycles.)**

(Attache de bicycles.)

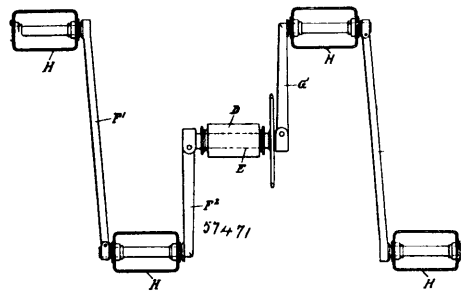

C. W. D. Manville and Walter Mann, both of London, Ontario, Canada, 18th September, 1897; 6 years. (Filed 9th February, 1897.)

*Claim.*—1st. The application to a bicycle of a combined double throw crank axle for pedals, substantially as and for the purpose set forth. 2nd. The combination of a combined double throw crank axle for pedals with a bicycle frame, substantially as and for the purpose set forth. 3rd. The application to a bicycle of a double seat or saddle bar, substantially as and for the purpose set forth. 4th. The combination of a double seat or saddle bar with a bicycle frame, substantially as and for the purpose set forth. 5th. The application to a bicycle of a double handle bar, substantially as and for the purpose set forth. 6th. The combination of a double handle bar with a bicycle frame, substantially as and for the purpose set forth. 7th. The combination of a combined double throw crank axle for pedals, a double seat or saddle bar, a double handle bar and a bicycle frame, substantially as and for the purpose set forth.

**No. 57,472. Bicycle Lamp. (Lampe de bicycles.)**

The C. T. Ham Manufacturing Company, assignee of Charles Bergener, both of Rochester, New York, U.S.A., 18th September, 1897; 6 years. (Filed 11th August, 1897.)

*Claim.*—1st. In a lamp, the combination with the body, the burner cone and the air chamber beneath it having the central aperture, of the removable oil fount separated from the bottom of the lamp by an air space and having the burner co-operating with an aperture in the air chamber, means for supplying air to the

chamber, and detachable fastenings between the oil fount and body, substantially as described. 2nd. In a lamp, the combination with

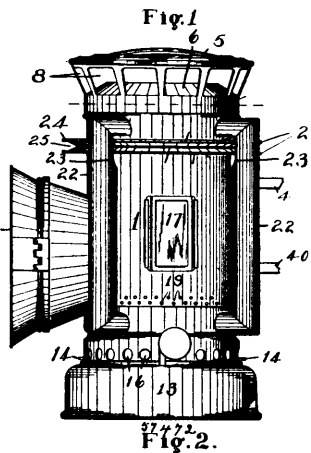

the body, the top, the burner cone, the bottom plate beneath the cone having the central aperture, of the removable oil fount detachably connected to the body and separated therefrom by an air space, the burner in the fount entering the aperture in the bottom plate, and air feeding devices at the upper portion of the body for supplying air beneath the burner cone, substantially as described. 3rd. In a lamp, the combination with the body having a bottom plate provided with an aperture, of the oil fount connected with the body by a detachable fastening and with an air space between the fount and plate, and a slip burner in the fount engaging the bottom plate at the edges of the aperture, substantially as described. 4th. The combination with the body, the window at the front and the air chamber at the bottom, of an air supply tube separated from the body and communicating with the air chamber, the burner cone above the air chamber, the oil fount detachably connected to the body and separated therefrom by an air space, and the burner tube in the fount entering the bottom of the air chamber and forming a tight joint therewith, substantially as described. 5th. The combination with the body having the perforations 16 and the plate 11, of the oil fount having the perforated flange 15, detachable fastenings between the fount and the body, and the burner 12 passing through and engaging the plate 11, substantially as described. 6th. The combination with the lamp body having the perforations 16 at the bottom and the plate 11, the cap 5 and plate 6 at the top, and the window at the front, of the oil fount having the perforated flange 15, the burner in the fount engaging plate 11, and detachable securing devices between the body and the fount, substantially as described. 7th. In a lamp, the combination with the body having the burner cone and the air chamber beneath it, of the annular air director at the upper portion of the body, one or more air tubes connected to the director and to the air chamber, substantially as described. 8th. In a lamp, the combination with the body, the burner cone, and the air chamber beneath the cone, of an air tube separated from the body and communicating with the air chamber beneath the cone and with the interior of the body above it, and air-feeding devices in the tube between its ends, substantially as described. 9th. In a lamp, the combination with the body, the burner, and the burner cone, of an air tube separated from the body and communicating at one end with the air chamber beneath the cone and at the other with the lamp body above the burner, air-feeding apertures intermediate the length of the tube, and an air director extending around the upper portion of the body for directing air to the tube, substantially as described. 10th. In a lamp of the character described, the combination with the burner, the burner cone, the air chamber beneath the cone, an air tube communicating with the body near the top and with the air chamber beneath the cone, air-feeding devices intermediate the length of the tube and the annular air director co-operating with the tube and composed of the plates and having the central air passage and overhanging flanges, substantially as described. 11th. In a lamp of the character described, the combination with the body, the burner, the burner cone and the air chamber beneath it, of the several air tubes connected to the air chamber at one end and to the body above the burner at the other, the annular air director, composed of plates 24, and the vertical dividing and directing plates 27, substantially as described. 12th. In a lamp of the character described, the combination with the annular air director having the central passage 25 and cut away at 26, of the vertical tubes 22 connected with the upper and lower parts of the body, having the openings 23 and the plates 27 therein, substantially as described. 13th. In a lamp of the character described, the combination with the body having the window at the front, the burner, the burner cone, and the air chamber beneath the cone, of the four air tubes connected at one end with the air chamber beneath the cone and at the other ends to the body above the burner, and having the openings intermediate their

lengths, and the vertical dividing plates therein, and the annular air director arranged opposite to and co-operating with the openings in the tubes, substantially as described.

**No. 57,473. Pneumatic Tire for Vehicles.**  
(*Bandage pneumatique pour véhicules.*)

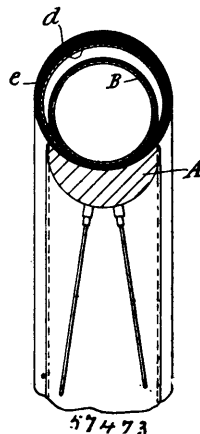

Annie Straus, New York, State of New York, U.S.A., assignee of Alexander Straus, same place, 18th September, 1897; 6 years. (Filed 16th August, 1897.)

*Claim.*—1st. The combination with a pneumatic tire of a protective cover, secured in fixed relation to the tire but normally free from attachment to or intimate contact with the tread portion of the same, and affording a surface upon which a tire bears at the point of contact with the ground, as set forth. 2nd. The combination with a pneumatic tire of a protective cover or sheath secured in fixed relation to the tire, but of substantially larger dimensions than the tire when fully inflated. 3rd. The combination with a pneumatic tire of a protective cover or sheath of substantially larger internal circumference than the tire when fully inflated and secured to the tire at its inner or seating portion only, as set forth. 4th. The combination with a pneumatic tire of a protective cover applied to and secured in fixed relation therewith, but normally free from attachment to or intimate contact with the outer or tread portions of the tire, and of such dimensions relatively to the tire, when the latter is inflated, as to permit the said cover to alter its shape independently of the tire, as set forth.

**No. 57,474. Pneumatic Tire.** (*Bandage pneumatique.*)

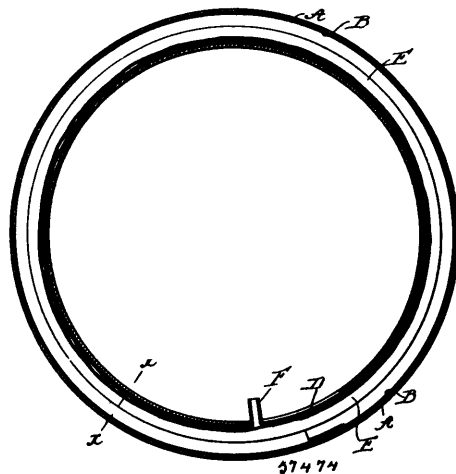

Morgan & Wright, assignee of Ernest W. Young, both of Chicago, Illinois, U.S.A., 18th September, 1897; 6 years. (Filed 19th August, 1897.)

*Claim.*—1st. The method of producing one-tube pneumatic tires, consisting in separately forming and vulcanizing an annular tubular pneumatic tire casing and a tin inner rubber tube therefor, introducing the inner tube within the casing and telescoping its ends, and uniting the outer surface of the inner tube to the inner wall by internal pressure and cementation, substantially as set forth. 2nd. The within-described method of producing one-tube pneumatic tires, consisting in forming and vulcanizing upon an annular mandrel and



endless seamless tubular structure composed of rubber and fabric, opening such structure to a limited extent and causing the mandrel to part from the same by way of such limited opening, introducing a tubular rubber layer through said limited opening and uniting the ends thereof so as to form an endless, annular, tubular rubber layer within the said tubular structure, cementing the outer side of the tubular layer to the inner side of the tubular structure wherein it has been so arranged, and compressing together the cemented sides by inflation. 3rd. As an article of manufacture, a pneumatic tire comprising a casing composed of rubber and fabric vulcanized together, and forming an endless annular tubular structure having limited slit, an inner separately vulcanized inflatable inner rubber tube united by cement to the inner walls of the casing and having telescoped ends, and suitable patching means confined within the inner tube, substantially as set forth.

**No. 57,475. Bicycle. (Bicycle.)**

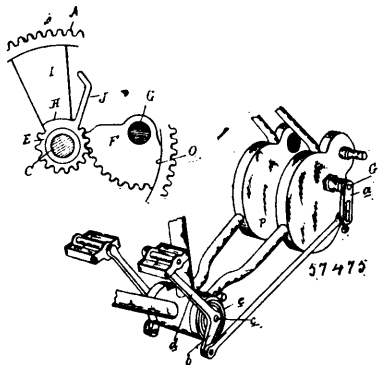

Wilhelm E. Nageborne and Fred C. Andrews, both of Detroit, Michigan, U.S.A., 18th September, 1897; 6 years. (Filed 21st August, 1897.)

*Claim.*—1st. In a drive gear, the combination of a flanged gear wheel, of an actuating device therefor comprising a concentrically arranged pinion or gear segment, a clutch for coupling the pinion or segment with the drive wheel, and a rocking sector within the circumference of the gear wheel, for rocking the pinion or segment. 2nd. In a drive gear, the combination of a flanged gear wheel, of an actuating device therefor, comprising a concentrically arranged pinion or gear segment within the flange, a clutch for coupling the flange on the wheel to the pinion, and a rocking sector within the circumference of the gear wheel for locking the pinion or segment and actuating the clutch. 3rd. In a drive gear, the combination with the gear wheel to be driven, of an actuating device therefor, comprising a combined pinion or gear segment and clutch actuating device, concentrically arranged, and the clutch and actuating devices for the pinion or segment. 4th. In a drive gear, the combination with the flanged gear wheel to be driven, a wheel or sleeve concentrically arranged within the flange, having a portion of its circumference formed into a gear segment and another portion carrying a dog actuated by the rotary motion thereof, and a rocking segment meshing with the gear segment on the inner wheel. 5th. The combination of a flanged gear wheel, having a hub projecting within the flange, a toothed wheel journaled on the hub, a clutch acting to bind the inner wheel to the gear wheel and a rocking segment within the flange meshing with the teeth on the inner wheel. 6th. The combination of a flanged gear wheel having a hub projecting within the flange, a wheel journaled on the hub having a gear segment thereon, a dog acting to bind the gear between the flange and the hub, while rotating in one direction, and to release in the opposite direction, and a rocking segment journaled beside the gear wheel, but within its flange, meshing with the teeth on the inner wheel. 7th. The combination with the flanged gear wheel, an inner wheel sleeved on its hub within its flange, and the dog actuated by the turning of the inner wheel in one direction to bind against the flange and to release in the opposite direction, and a stop or finger carried by the inner wheel to hold the dog in proper position during its return movement. 8th. The combination of the flanged gear wheel, the inner wheel journaled on the hub of the gear wheel within the flange, the block or dog I adapted to be forced against the flange by the turning in one direction of the inner wheel, and to be released by the opposite movement, and a stop, such as L, at the end of the return movement, to hold the dog for the purpose described. 9th. The combination with a gear wheel, a concentric inner wheel, having a toothed portion, a clutch adapted to connect the two wheels, of a rocking segment for actuating the inner wheel, said segment forming a brake when moved beyond its normal travel. 10th. In a drive gear, the combination with rocking or vibrating pedals, adapted to intermittently actuate a gear wheel through a gear and clutch mechanism, such as described, in the normal motion of the pedals, of means for releasing the clutch mechanism, and applying a brake, by a movement of the pedals beyond the normal.

**No. 57,476. Wheel for Vehicles.**

(Roue pour véhicules.)

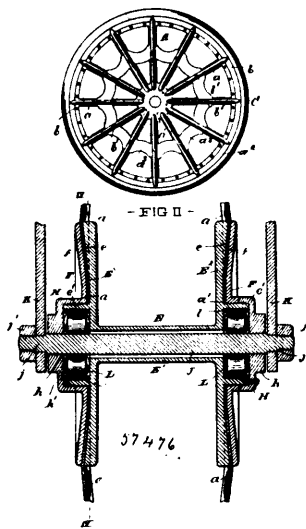

The Stamped Steel Vehicle Wheel Co., assignee of James White, both of Cleveland, Ohio, U.S.A., 18th September, 1897; 6 years. (Filed 23rd August, 1897.)

*Claim.*—1st. In a vehicle wheel, the combination of a sleeve provided at both ends with rigid vertical flanges formed with radial spoke seats upon their outer faces, two skeleton sheet metal discs, each having a central disc portion and cut out to form spokes formed with longitudinal corrugations extending into said central disc portion, two collars provided upon their inner faces with spoke seats corresponding and registering with the inner ends of the spokes and with the seats in the vertical flanges, and means for forcing and holding said collars against the disc portions and flanges, causing said portions and the inner spoke ends to be firmly clamped between the flanges and collars, substantially as set forth. 2nd. A vehicle wheel having in combination, a sleeve provided at both ends with rigid vertical flanges constructed with radial tapering corrugations on their outer faces, two skeleton sheet metal discs each having corrugated spokes connected with each other by a continuous web at their inner ends, two collars provided on their inner faces with radial corrugations, and means for clamping the collars, the skeleton discs, and the vertical flanges to each other, substantially as set forth. 3rd. A vehicle wheel having in combination, a sleeve having at both ends vertical flanges provided upon their outer faces with convex tapering seats which project from intervening flat surfaces of the flanges, two skeleton sheet metal discs each having corrugated spokes and a continuous flat web connecting the inner ends of the spoke corrugations, two collars provided upon their inner faces with concave spoke seats, and means for clamping the collars, the sheet metal discs and the vertical flanges to each other, substantially as set forth. 4th. A vehicle-wheel having in combination, a sleeve provided at both ends with rigid vertical flanges formed with radial spoke seats on their outer faces, two skeleton sheet metal discs each having corrugated spokes, a continuous web connecting the inner ends of the spoke corrugations, and the tie webs connecting the spokes between their ends, transverse ties connecting the spokes of opposite discs between the ends of the spokes, collars provided upon their inner faces with spoke seats corresponding to those of the vertical flanges, and means for clamping the collars, the skeleton discs and the radial flanges to each other, substantially as set forth. 5th. A vehicle-wheel having in combination, a radially ribbed flange, sheet metal spokes which are corrugated to receive the ribs, the ends of the spokes being connected with each other by intervening sheet metal adapted to engage with the flange between the sides of adjacent spokes, a collar adapted to engage with the flange between the corrugated spokes and with the sheet metal between the inner ends of the spokes, and means for clamping the flange, the spokes and the collar together, substantially as set forth. 6th. A vehicle-wheel having in combination, sheet metal spokes projecting from a disc which has a central opening, a vertical flange having a horizontally projecting neck adapted to enter the disc opening, a collar surrounding the horizontal neck and a flanged cap mounted on the horizontal neck and engaging the collar, substantially as set forth. 7th. A vehicle-wheel having in combination, a radially ribbed vertical flange, sheet metal spokes which are corrugated to receive the ribs and project from a disc having a central opening, a horizontal neck projecting from the vertical flange and adapted to enter the disc opening, a radially grooved collar surrounding the horizontal neck, and a flanged cap mounted on the horizontal neck and engaging the grooved collar, substantially as set forth. 8th. A vehicle-wheel

having in combination, corrugated sheet metal spokes projecting from a disc, a radially ribbed vertical flange having a central opening, a horizontal neck projecting from the vertical flange at some distance from the central opening and concentric therewith, a collar surrounding the horizontal neck, a flanged cap mounted on the horizontal neck and engaging with the collar and having a central opening corresponding to the opening of the vertical flange, whereby there is formed between the vertical flange and the flanged cap a circular chamber for the reception of anti-friction rollers, substantially as set forth. 9th. A vehicle-wheel having a series of corrugated sheet metal spokes, a central disc, and an outer rim which is flanged to receive a tire, the outer ends of the spoke corrugations extending outward across the tire flange, substantially as set forth. 10th. A vehicle-wheel having a series of corrugated spokes, a central disc, an outer rim formed with oppositely projecting flanges, the outer ends of the spoke corrugations extending across the projecting flanges on opposite sides of the wheel, substantially as set forth. 11th. A vehicle-wheel having in combination, a series of corrugated spokes, a central disc, an outer rim formed with oppositely projecting flanges, the outer ends of the spoke corrugations being tapering and extending across the projecting flanges on opposite sides of the wheel, substantially as set forth.

**No. 57,477. Bicycle Support. (Support de bicycles.)**

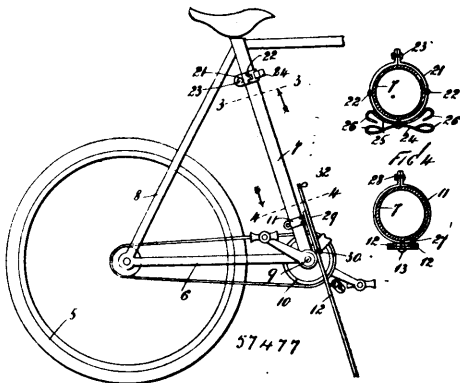

August Herman Cronemeyer, New York, Henry Luis Robert Cronemeyer and Edward William Prophyl Sehning, both of West Farms, all in the State of New York, U.S.A., 18th September, 1897; 6 years. (Filed 25th August, 1897.)

*Claim.*—1st. The herein described lock and support for a bicycle, the same consisting of a clamp or band which is adapted to be connected with one of the rods of the frame adjacent to one of the wheels thereof, and two legs pivotally connected therewith one of said legs being provided with a chain or similar device, and a lock by which it may be secured to the other, said legs being provided with inwardly directed curves or bends at the points where said chain is connected therewith, and a clamp or band provided with spring arms and adapted to be secured to the chain of the bicycle, above said first named clamp or band, said spring arms being adapted to serve as supports for said pivoted legs when the latter are not in use to support the bicycle, and means for raising said legs and for lowering the same, substantially as shown and described. 2nd. The herein described lock or support for a bicycle, the same consisting of a clamp or band which is adapted to be connected with one of the rods of the frame adjacent to one of the wheels thereof, and two legs pivotally connected therewith, one of said legs being provided with a chain or similar device, and a lock by which it may be secured to the other, said legs being provided with inwardly directed curves or bends at the points where said chain is connected therewith, and a clamp or band provided with spring arm and adapted to be secured to the frame of the bicycle, above said first-named clamp or band, said spring arms being adapted to serve as supports for said pivoted legs when the latter are not in use to support the bicycle, and means for raising said legs and for lowering the same, consisting of bars pivotally connected at one end, and with said legs at the other end, and projecting upwardly therefrom, said bars being provided at their upper ends with a knob or handle, substantially as shown and described.

**No. 57,478. Gearing for Velocipedes. (Engrenage de velocipedes.)**

Andrew Jackson McDuffee, assignee of Jesse Walter Sunderland, both of Chicago, Illinois, U.S.A., 18th September, 1897; 6 years. (Filed 28th August, 1897.)

*Claim.*—1st. In a velocipede of the class described, the combination with the frame, drive-wheel, a pinion rigid with the drive-wheel shaft, an externally toothed gear-wheel meshing with the pinion, a housing inclosing said pinion and gear and maintaining their connection, a crank-shaft journalled in the frame, a crank thereon,

and a connecting-rod journalled at one end upon said crank and rigidly attached at its opposite end to said gear-wheel at its outer

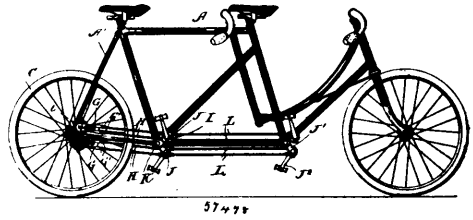

side, said connecting-rod being provided with an offset to permit movement with relation to said housing and to preserve the alignment, substantially as and for the purpose set forth. 2nd. In a velocipede of the class described, the combination with the frame, and drive-wheel provided with rigid shaft journalled in the frame, said shaft having the successively reduced threaded sections, of a crank-shaft provided with a crank journalled in the frame, a connecting rod journalled on said crank, a housing-bearing cone *p* screwed onto said drive-wheel shaft, a pinion *D* screwed onto the shaft adjacent to said cone, a second housing-bearing cone *n* upon the extreme end of the shaft adjacent to the pinion, a housing provided with race-members to co-act with said housing-bearing cones, a gear-wheel inclosed in the housing meshing with the pinion and provided with anti-friction bearings, and connecting-means between the planet-gear and the rear-end of said connecting-rod for maintaining said parts in rigid relation to each other, all arranged substantially as described and operating in the manner specified. 3rd. In a velocipede of the class described, the combination with the frame and drive-wheel provided with a rigid shaft journalled in the frame, of a pinion rigid with the shaft, a gear-wheel meshing therewith, a housing for maintaining said gears in proper relation, a crank-shaft provided with a crank journalled in the frame, a journal-box on the crank, a plate or forging *G* rigidly attached to said gear-wheel at the outer side thereof and provided with an offset to permit movement with relation to said housing and to preserve the alignment, and a connecting-rod *H* provided with right and left-handed threads joining the front end of said forging rigidly and adjustably to the box journalled upon said crank, substantially as set forth. 4th. In a velocipede of the class described, the combination with the frame, of a drive-wheel having a shaft provided at its ends with successively reduced threaded sections, inner housing-bearing cones *p*, pinions *D*, and outer housing-bearing cones *n* successively screwed onto said sections, planet gears *F* meshing with said pinions, housings inclosing the gears and pinions and maintaining them in proper relationship and each provided with race-members to co-act with the members *p* and *n*, forgings *G* provided with offsets to preserve the alignment, bolt and pin connection between the planet gears and forgings for maintaining them in rigid connection, cranks journalled in the frame, journal-boxes thereon, adjustable connecting-rods joining journal-boxes, and adjustable connecting-rods joining the rear journal-boxes and the front ends of said forgings, substantially as set forth. 5th. In a velocipede, the combination with the frame, drive-wheel, crank-shaft journalled in the frame, crank upon said shaft, and connection-rod operatively joined to the drive-wheel, of an internally threaded journal-box upon the crank split at one side of the crank and provided with perforated lugs, a race-member upon the crank, externally threaded cones *I* to co-act therewith and a bolt through said lugs for locking said cones after their adjustment is perfected, substantially as described.

**No. 57,479. Toe-Clips for Bicycle Pedals. (Gâche pour pédales de bicycles.)**

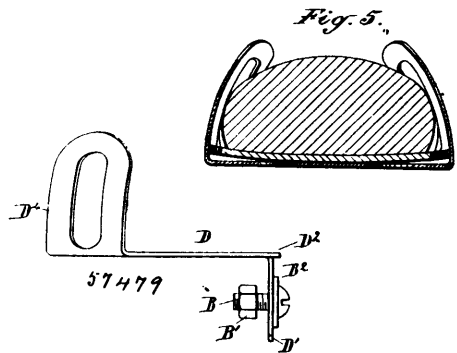

The Buescher Manufacturing Company, assignee of Henry Lee Young, both of Elkhart, Indiana, U.S.A., 18th September, 1897; 6 years. (Filed 3rd September, 1897.)

*Claim.*—1st. A toe-clip provided with rearwardly-projecting horns to engage the upper edge of the pedal, adapted to serve as herein specified. 2nd. In a toe-clip for a bicycle pedal, the rearwardly-extending horns formed integrally with the clip and adapted to engage the pedal and to serve therewith, and with fastening means B, B<sup>1</sup>, substantially as herein specified. 3rd. A toe-clip for bicycle pedals, comprising the main body-portion and side-wings for the toe extending upwardly and inwardly, so set and shaped as to engage only the sole of the shoe under ordinary conditions, the downwardly-bent lug having the slot to receive the fastening screw, and the rearwardly-projecting horns, the whole formed integral, substantially as herein specified. 4th. The within-described toe-clip, comprising the main body-portion tapering forward, provided with upwardly and inwardly-curved wings D<sup>4</sup> and D<sup>5</sup> set in correspondingly oblique positions, the rear portion of the clip having the extended horns D<sup>2</sup>, D<sup>3</sup>, and downwardly-extending lugs D<sup>1</sup>, having the slot *d*, the whole formed integral, substantially as shown and described.

**No. 57,480. Egg and Fruit Case.**  
(Boîte à œufs et fruits.)

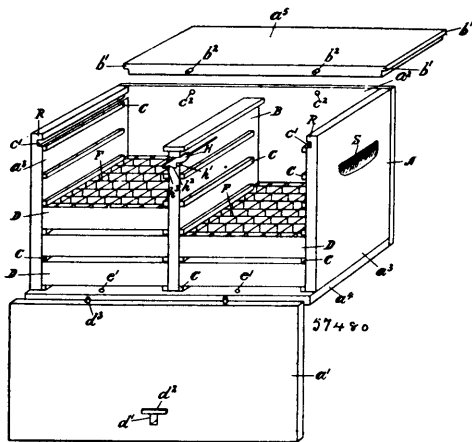

William Wilson, London, Ontario, Canada, 20th September, 1897; 6 years. (Filed 23rd July, 1897.)

*Claim.*—As a new article of manufacture, an egg and fruit case, consisting of the body A, provided with the front a<sup>1</sup>, and means for securing the latter in place, the cleats or battens C, C, the yielding trays D, D, the cells or fillers F, F, and the yielding cushion or packing G, substantially as and for the purposes hereinbefore set forth.

**No. 57,481. Lock.** (Serrure.)

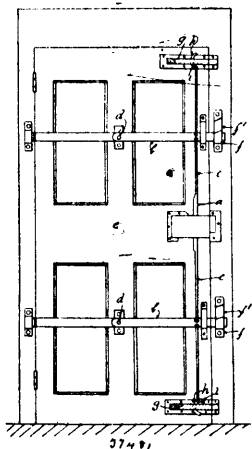

Arthur Cripps, Hoxton, Middlesex, England, 20th September, 1897; 6 years. (Filed 7th July, 1897.)

*Claim.*—1st. In a lock as herein described: a sliding bolt operating locking or bolting bars through the medium of suitable levers or rods; said sliding bolt being operated by a key which operates upon wards; one or more of said wards having a curved projection or surface upon same, so that the movement of the key will give said ward or wards a movement in first one and then another direction; said sliding bolt locking or securing a latch when in its locked

position, substantially as described and illustrated herein. 2nd. In a lock as herein described: socket pieces having openings or slots so arranged that the bolt or bar can only leave the socket piece when in a certain position—that is, opposite the opening or slots in the socket piece.

**No. 57,482. Shingling Bracket.**  
(Console pour couvrir en bardeau)

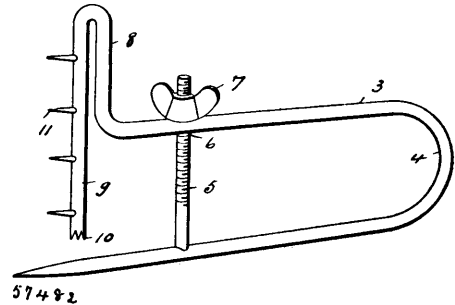

Isaac Hosier, Philmont, New York, U.S.A., 20th September, 1897; 6 years. (Filed 6th September, 1897.)

*Claim.*—1st. A shingling bracket made from a metal strip bent in U-shape and sharpened at one end to enter beneath a shingle, the opposite end being bent to form an arm which extends at substantially right angles to the lower arm of the main body portion, and provided at its extremity with teeth or spurs to engage the shingle, one arm of the bracket having a shank or bolt which extends through an opening in the opposite arm, where it is provided with a thumb-screw, substantially as and for the purpose described. 2nd. The herein-described shingling bracket, comprising a U-shaped body portion embodying substantially parallel arms, the end of one arm being formed for insertion beneath the shingle, and the end of the remaining arm being bent away from the first-named arm and then re-curved or bent upon itself and extended towards the first-named arm, and at substantially a right angle thereto, the said right-angular arm being provided at its extremity with teeth or spurs and along its length with laterally-projecting spurs or prongs, and a shank or bolt connected rigidly to one of the main arms, and extending through an opening in the opposite arm where it is provided with an adjusting nut, substantially as and for the purpose specified.

**No. 57,483. Ruling Machine.** (Machine à régler.)

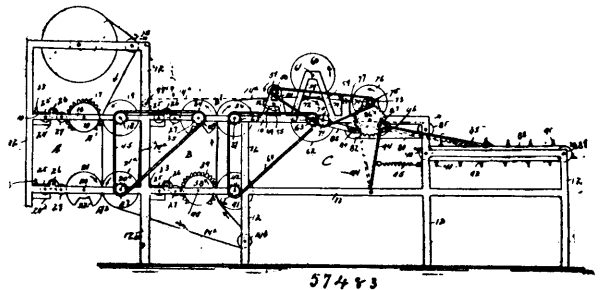

Frank Hudson, Covington, Kentucky, U.S.A., 20th September, 1897; 6 years. (Filed 9th August, 1897.)

*Claim.*—1st. A ruling machine, comprising ruling devices arranged one above the other for ruling the paper transversely and longitudinally, one of the ruling devices consisting of a drum having longitudinal rules, and an impression roller, and the other disc-rules, and an impression roller, cutters arranged in rear of the ruling devices for cutting the paper longitudinally, a cutter in rear of the first cutter for cutting the paper transversely, and feed-rollers between the said cutters, substantially as described. 2nd. A ruling machine comprising two sets of ruling devices arranged one in rear of the other for ruling the paper longitudinally and transversely on both sides, each set consisting of a drum having longitudinal rules, disc rules and impression rollers for said drum and discs, cutters arranged in rear of the ruling devices for cutting the paper longitudinally, a cutter in rear of the first cutter for cutting the paper transversely, feed-rollers between the cutters, and an endless conveyor provided with pockets receiving the sheets of paper, substantially as described. 3rd. In a ruling machine, the combination with a support for a roll of paper, a drum mounted below the said support and provided with a series of longitudinally-disposed rules, a revolving impression-roller for the horizontal rules, a shaft located beneath the horizontal rules, disc rules adjustable on the said shaft, an impression roller for the disc rules, and inking devices for both

of the rules, of a series of cutters in rear of the rules and arranged to cut the material longitudinally, cutters arranged in rear of the first cutters and adapted to cut the material transversely, and feed-rollers between the two cutters, as and for the purpose set forth. 4th. In a ruling machine, the combination of two sets of ruling devices arranged in rear of one another for ruling the paper transversely and longitudinally on both sides, each set comprising a drum having longitudinal rules, disc rules and impression rollers for said drum and discs, a plurality of cutters arranged in rear of the ruling devices for cutting the paper longitudinally into strips and a cutter in rear of the said cutters for cutting the strips transversely into lengths, substantially as described. 5th. In a ruling machine, the combination with a support for a roll of paper, a drum mounted below the said support, and provided with a series of longitudinally disposed rules, a revolving impression roller or cylinder for the horizontal rules, a shaft located beneath the horizontal rules, disc rules adjustable upon the said shaft, an impression roller for the disc rules, of a series of cutters in rear of the rules, and arranged to cut the material longitudinally, cutters arranged in rear of the first cutters and adapted to cut the material transversely, a feed device between the two cutters, a conveyer provided with pockets for receiving the material from the cutters, and a device for regulating the movement of the conveyer, whereby each pocket will receive a predetermined number of sheets, as and for the purpose specified. 6th. In a ruling machine, the combination with ruling devices arranged one above the other for ruling the paper on one side transversely and longitudinally, comprising a drum having longitudinal rules, disc rules, and impression rollers for the drum and discs, cutters in rear of the second set of ruling devices for cutting the paper into strips, and a cutter in rear of the said cutters for cutting the strips into lengths, substantially as specified. 7th. In a ruling machine, the combination with ruling devices arranged one above the other for ruling the paper on one side transversely and longitudinally, of a second set of ruling devices arranged one above the other, and in rear of the other set for ruling the other side of the paper transversely and longitudinally, cutters in rear of the second set of ruling devices for cutting the paper into strips, a cutter in rear of the said cutters for cutting the paper into lengths, and feed-rollers between the cutters, substantially as described. 8th. In a ruling machine, the combination with ruling devices for ruling the paper transversely and longitudinally on both sides, of cutters arranged in rear of the ruling devices for cutting the paper longitudinally into strips, a cutter for cutting the paper transversely into lengths, feed-rollers between the cutters, a carrying-belt for receiving the sheets of paper, a conveyer provided with pockets for receiving the sheets from the carrying belt, and means operated from the transverse cutter for imparting intermittent motion to the conveyer, substantially as described. 9th. In a ruling machine, the combination with ruling devices for ruling the paper transversely and longitudinally on both sides, of cutters arranged in rear of the ruling devices for cutting the paper longitudinally into strips, a cutter for cutting the paper transversely into lengths, feed-rollers between the cutters, a carrying-belt for receiving the sheets of paper, a conveyer provided with pockets for receiving the sheets from the carrying belt, and means operated from the transverse cutter for imparting intermittent motion to the said conveyer, substantially as described. 10th. The combination, with rotary cutters and their driving mechanism, of a conveyer belt provided with pockets, a gear operating in conjunction with the rotary cutters, and travelling at a lesser speed, the said gear being provided with a wrist-pin, a shifting arm having one end formed for engagement with the pockets on the conveyer, and a lever, tension-controlled in one direction and operated in the opposite direction by the aforesaid wrist-pin, the said lever carrying the said shifting arm, as and for the purpose set forth. 11th. In a ruling machine, the combination of an endless carrier provided with pockets, a pivoted and spring pressed lever, a shifting arm pivoted to the lever, and having its free end engaging projections on the carrier, and means for swinging the lever to place the spring thereof under tension and then releasing the same, substantially as described. 12th. In a ruling machine, the combination with an endless carrier provided with pockets and lugs projecting from one side, of a pivoted and spring pressed lever, a shifting arm pivoted to the lever, and engaging the lugs of the carrier and a wheel provided with a wrist-pin engaging the lever to swing it forward to place the spring thereof under tension, and then releasing the same, substantially as specified.

**No. 57,484. Gun-swab. (Appareil pour nettoyer les fusils.)**

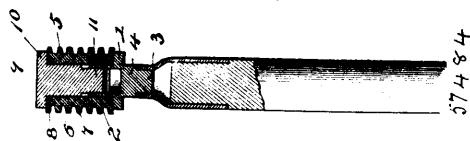

Jabez Ferdinand Warner, Prophetstown, Illinois, U.S.A., 20th September, 1897; 6 years. (Filed 19th August, 1897.)

*Claim.*—1st. A gun-swab, comprising a head having at one of its sides an internally-threaded neck, and at its other sides provided

with means for attachment to a suitable handle, an expansible sleeve mounted upon said internally-threaded neck, said sleeve being provided with exterior annular corrugations forming peripheral biting-teeth, and an adjusting-nut for holding said sleeve upon the internally-threaded neck, said nut having a threaded stem passing through the sleeve and into engagement with the internally-threaded neck, and a disc-like head contracting with one end of the sleeve, whereby said sleeve may be compressed and laterally expanded, substantially as set forth.

**No. 57,485. Drying Apparatus, (Appareil à sécher.)**

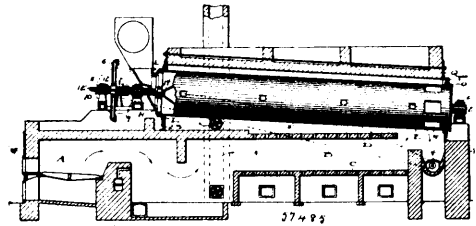

Franklin David Cummer, Cleveland, Ohio, U.S.A., 20th September, 1897; 6 years. (Filed 27th August, 1897.)

*Claim.*—1st. In a drying apparatus, a drying cylinder, a spider in the end of the cylinder, a hollow trunnion for said spider, a spring pressed rod through said trunnion, and arms connected with the inner end of said rod and the inside of said cylinder back from the end thereof, substantially as set forth. 2nd. The drying cylinder and ring fixed thereto at one end and a journaled spider encircled by said ring, a rod through the journal of said spider and connecting arms from the inner end of said rod to the inside of the cylinder, said rod provided with a spring to yield longitudinally, substantially as set forth. 3rd. The construction described consisting of the cylinder and the ring about its front end, the hollow journaled spider having a ring shaped periphery overlapped by the ring on said cylinder and the said rings constructed to engage and rotate together whereby the cylinder is turned, a rod through said spider journal, a spring encircling the rod outside said journal and the yoke or arms connected with the inner end of said rod and the inside of the cylinder, substantially as set forth. 4th. The cylinder and the ring fixed to the end thereof, in combination with a spider having its periphery overlapped by the said ring and having a projection on its periphery against which the said ring is adapted to bear, connections independent of said spider to hold said ring and spider in operative relation, said connections fixed to the said cylinder some distance from its ends, substantially as set forth. 5th. In a drying apparatus, as described, a drying cylinder having hooded inlets between its ends for the passage of the products of combustion and heated air and openings at its rear and side for the further inlet of products of combustion and for the discharge of the dried material, substantially as set forth. 6th. The drying cylinder described, having a series of openings about its rear and side through which the dried material is discharged and the products of combustion are admitted to said cylinder, and having a supporting spider and journal in its rear end outside said openings, substantially as set forth. 7th. In a drying apparatus, a furnace and heating chamber and a rotating drying cylinder in said chamber, in combination with a dust collecting chamber and a walled passage in said chamber constructed to promote deposition of the dust, a draft passage from said cylinder to said walled passage, and a blower to promote artificial draft through said passages, substantially as described. 8th. The apparatus comprising the furnace and heating chamber and a rotating cylinder in said chamber, in combination with a dust collecting chamber over the said heating chamber, a draft passage from the cylinder to said chamber, and a blower in said passage, substantially as described. 9th. The dust chamber described having an inlet from the furnace and a blower connected therewith, and a passage-way in said chamber provided with an opening along its bottom and closed about its sides and top and an outlet at the top of said chamber for the escape of the products of combustion, substantially as set forth. 10th. In a drying apparatus, a dust collecting chamber provided with an inlet passage extending into the same and open along its bottom, and the deflector or guard along the sides and bottom of said passage to promote the deposit of the inflowing dust at the bottom of said chamber, substantially as described. 11th. In a drying apparatus as described, a cylinder through which the products of combustion and the material dried pass in opposite directions, in combination with a dust chamber, a flue from said cylinder into said dust chamber and a blower in said flue, said dust chamber provided with means to promote the depositing of the dust at the bottom of said chamber, and the said chamber having sides converging toward the bottom thereof substantially as set forth. 12th. The dust chamber having an outside inclosing wall and inside downwardly converging sides 70, and a conveyer at the bottom of said sides 70, substantially as set forth. 13th. The dust chamber having the converging inner side walls and the con-

veyer at the bottom thereof, in combination with the dust inlet passage extending into said chamber and open along its bottom, and an outlet at the top of said chamber, substantially as set forth.

**No. 57,486. Bedstead. (Bois de lit.)**

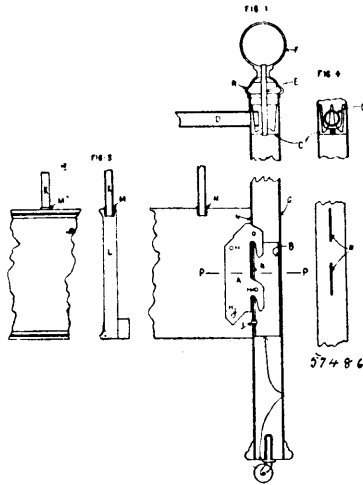

Thomas Herbert Stephenson, Toronto, Ontario, Canada, 20th September, 1897; 6 years. (Filed 12th May, 1897.)

*Claim.*—1st. In a device of the class specified, the combination with the metal upright post G, of the wrought iron tube B, inserted within the post G, and securely attached thereto, and having slots N, formed in the post G, and tube B, the side or end rail L, the hooked metal lugs A, secured to the rail and designed to engage with the slots N, substantially as specified. 2nd. In a device of the class specified, the combination with the upright metal post G, of the metal cup C, with wedge D<sup>1</sup>, formed therein, the tube D, with holes formed therein near its end to receive the wedge D<sup>1</sup>, and the screw E, passing through the cup C, and operated by the cap F, so as to retain the wedge D<sup>1</sup> securely within the holes formed in the tube D, substantially as described and for the purpose specified. 3rd. In a device of the class specified, the combination with the tube or bar K, of the rail L, and the thimble N, let into the rail to receive the end of the tube K, substantially as described and for the purpose specified.

**No. 57,487. Mantles or Hoods for Incandescent Gas Lamps. (Manteau de lampe incandescente à gaz.)**

The Apollo Incandescent Gas Light Co., assignee of Ernest Neinstaedt, both of New York, State of New York, U.S.A., 20th September, 1897; 6 years. (Filed 17th May, 1897.)

*Claim.*—1st. A composition for incandescing mantles or hoods the same consisting of nitrate of yttrium, nitrate of magnesia, nitrate of cerium, nitrate of thorium, nitrate of rhodium, nitrate of bismuth, nitrate of tin, and boracic acid, in the proportions set forth. 2nd. A compound for incandescing mantles or hoods including a nitrate of rhodium, nitrate of bismuth and boracic acid, substantially as described. 3rd. As an article of manufacture, a burned mantle or hood containing nitrate of rhodium, nitrate of bismuth and boracic acid as compound parts among certain refractory earths, substantially as set forth.

**No. 57,488. Invalid's Bed. (Support pour invalides.)**

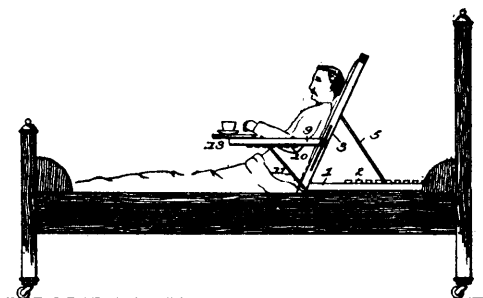

57488

Jennie Drawe, John Drawe and William Perrin, all of Maine, Michigan, U.S.A., 20th September, 1897; 6 years. (Filed 16th August, 1897.)

*Claim.*—1st. In an invalid rest, comprising a bottom frame 1, a rest frame 3, of greater width than the bottom frame, means for supporting such frame at different inclines, side arms vertically adjusted to the said rest frame, and a wire bail having portions extended through the meeting ends of the rest and the bottom frame and having vertical members adapted to form supports, of the side arms and a food rest held upon such side arms, all being arranged substantially as shown and for the purposes described. 2nd. The combination with the bottom frame 1, having rack members 2, at the inner edges thereof, the hinge frame of a greater width than the bottom, having side members adapted to close down over the sides and the end of the bottom member, said side members having vertical slots, and the bail 5, hinged to the frame to engage the racks 2, of the side arms 9, having their inner ends connected to the rest frame provided with racks on their under faces and eyes or loops, a wire bail having portions extended through the meeting ends of the bottom and rest frame to form hinges therefor, and having vertical members to engage the racks of the side arms 9, and a food rest consisting of a cross member adapted to rest upon the said side arms 9, and having wire side extensions to fit the loops on such arms 9, all being arranged substantially as shown and for the purposes described. 3rd. An invalid rest, comprising a bottom frame 1, having racks 2, a rest frame 3, of greater width than the bottom frame, hinged to such bottom frame and held spaced apart therefrom, means for holding such rest frame to its different inclines, a cross bail 11, having portions extended through the bottom and the rest frame to form hinged members therefor, and vertical members, arms 9 vertically adjustable on and connected to the rest frame and sides, and a food supporting table adapted to be supported longitudinally on such arms 9, all being arranged substantially as shown and described.

**No. 57,489. Boot Cleaning Machine. (Machine à nettoyer les chaussures.)**

(Machine à nettoyer les chaussures.)

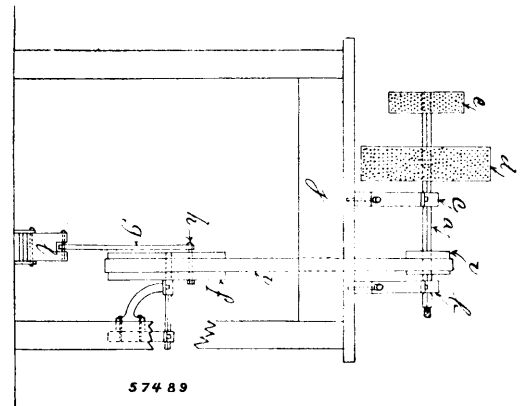

57489

Peter Fraser, Middlesex, London, England, 20th September, 1897; 6 years. (Filed 30th August, 1897.)

*Claim.*—A new or improved boot cleaning and brushing machine consisting of two circular brushes mounted upon a spindle of sufficient distance apart, said spindle being driven by means of a band and pulley, said band being operated by a fly-wheel and foot treadle, the whole being carried in a suitable support or frame, substantially as described.

**No. 57,490. Vehicle Axle. (Essieu de voitures.)**

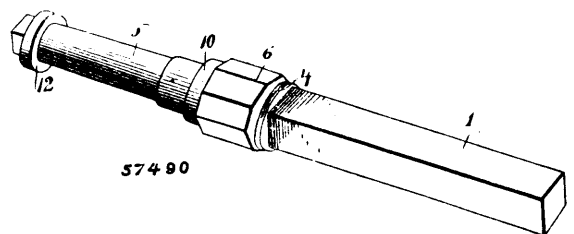

57490

Benjamin Franklin Westmoreland and Robert Hugh Balington, both of Franklinton, Louisiana, U.S.A., 20th September, 1897; 6 years. (Filed 10th August, 1897.)

*Claim.*—1st. The axle 1, having the cylindrical shank 2, threaded end 3, and the correspondingly threaded collar 4, in combination with the detachable skein or thimble 5, formed with the internally threaded polygonal sleeve 6, reinforced collar 10, and the threaded socket 8, substantially as shown and described. 2nd. The axle 1, having the cylindrical shank 2, threaded end 3, and correspondingly threaded collar 4, in combination with the screw stud 9, adjustably secured in the end of said axle, and the detachable skein or thimble

5, provided with the internally threaded polygonal sleeve 6, reinforced collar 10, and the threaded socket 8, substantially as shown and described.

**No. 57,491. Non-refillable Bottle.** (*Appareil pour empêcher le remplissage des bouteilles.*)

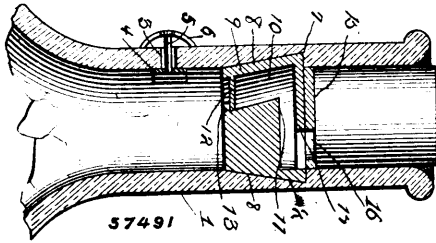

Victor R. Roth and William L. Roth, both of Philadelphia, Pennsylvania, U.S.A., 20th September, 1897; 6 years. (Filed 6th September, 1897.)

*Claim.*—1st. A bottle provided with an outwardly opening valve situated in the neck thereof, and a vent opening through the wall of said neck below said valve. 2nd. A bottle provided with an outwardly opening valve situated in the neck thereof, a vent opening through the wall of said neck below said valve, a button or plate situated within said neck for closing said vent opening, and a spring upon the outside of said neck connected with said button or plate. 3rd. A bottle provided with an outwardly opening valve situated within the neck thereof, a vent opening through the wall of said neck situated below said valve, a button or plate situated within said neck, a spring upon the outside of said neck, and a pin or cord connected with said spring and said button or plate. 4th. A bottle having a neck provided with an interior groove having an abrupt upper wall, an inclined side wall, a valve casing conforming in contour to said groove and situated within the same and having a circuitous passage, an outwardly opening valve within said passage, and a vent opening through the wall of neck of said bottle, below said groove. 5th. A bottle having a neck provided with a groove having an abrupt upper wall, and an inclined side wall, a valve casing conforming in contour to said groove and situated within the same, a circuitous passage through said valve casing, an outwardly opening valve in the lower end of said valve casing, and a protecting plate situated within said neck and over said valve casing.

**No. 57,492. Rail Fastener.** (*Attache de rails.*)

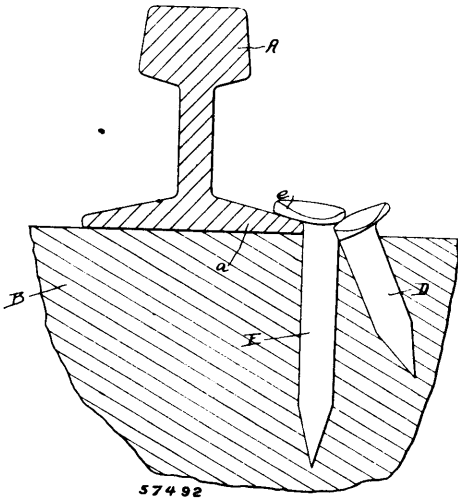

William Richenbaugh Gerhart, Lancaster, Pennsylvania, U.S.A. 20th September, 1897; 6 years. (Filed 2nd August, 1897.)

*Claim.*—1st. The combination, with a stay, of a spike securing the rail to a tie and bearing diagonally downward on said stay, for the purpose specified. 2nd. The combination, with a stay, of a spike driven vertically into the tie and securing the rail thereto, the spike bearing diagonally downward on the stay, for the purpose specified. 3rd. The combination, with a rail and a penetrable cross-tie, of a stay-spike having a recess therein adjacent to the rail, and a spike engaging said recess and the rail, substantially as and for the purpose specified. 4th. The combination, with a rail and a penetrable cross-tie, of a stay-spike provided with a flanged head having a recess therein, and a spike engaging said recess and the rail, for the purpose specified.

**No. 57,493. Car Door Catch.** (*Arrêt pour portes de chars.*)

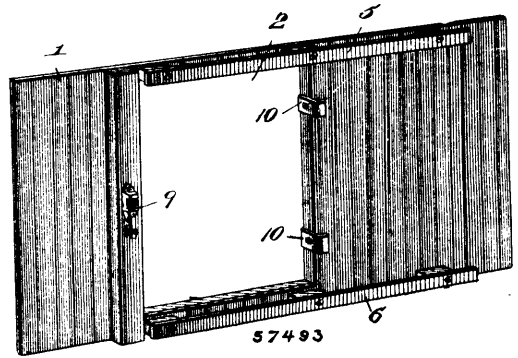

William K. Edgar and William L. Sebring, both of Colorado Springs, Colorado, U.S.A., 20th September, 1897; 6 years. (Filed 1st August, 1897.)

*Claim.*—The combination of a sliding car-door provided at its rear inner edge with spaced mortises, a metal plate 12 fitted to the rear inner edge of the door and formed with notches 14 leading into said mortises and producing stop-shoulders 15, and L-shaped catch-hooks adapted to be secured to the rear edge of the car-door opening and having their outer portions disposed obliquely to the attached portions thereof and engaging at said mortises at the inner side of the plate 12, to provide for drawing the rear edge of the car-door inward against the car-body, said hooks also resting in the notches of the plate 12 so as to engage against said stop-shoulders 15 and prevent upward or downward movement of the car-door, substantially as set forth.

**No. 57,494. Mop Wringer.** (*Essoreuse de torchon.*)

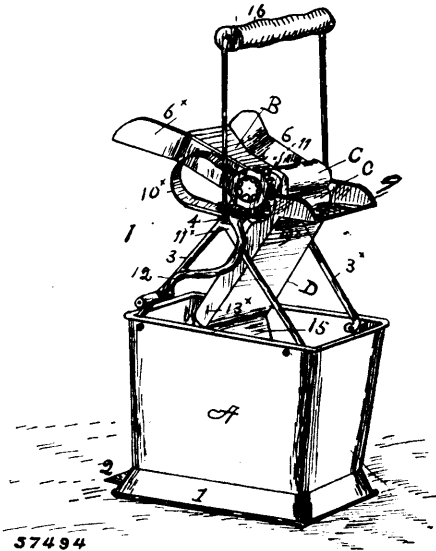

John A. Higgins, Mainstee, Michigan, U.S.A., 20th September, 1897; 6 years. (Filed 23rd July, 1897.)

*Claim.*—1st. A mop-wringer, comprising a pail, a frame mounted on the pail, an inclined mop-plate having side flanges extending beyond the lower end of the plate, suitable journaled wringing rollers having the extensions of the mop-plate arranged between their journals, means to rotate the rollers, a chute D reversely inclined to the mop-plate, formed with side flanges, and having its upper end secured to the extensions of the mop-plate, and a plate extending from the lower end of the plate D into the pail and forming a partition dividing the pail into two compartments. 2nd. A mop-wringer, comprising a pail, rectangular in cross-section, a supporting frame composed of bars having their lower ends secured in the corners of the pail and their upper ends united, a cross-bar uniting the opposite frames, an inclined mop-plate formed with side flanges extending beyond the lower end of the plate, a reversibly inclined chute D having its upper end secured to the extensions of the mop-plate, and formed with an extension reaching into the pail and dividing it into two compartments, wringing rollers journaled in the opening at the foot of mop-plate, intermeshing gears on the journals f said rollers, and a crank to rotate the rollers.



**No. 57,495. Snow-Sled Engine or Motor Sled.**  
(*Traineau à moteur.*)

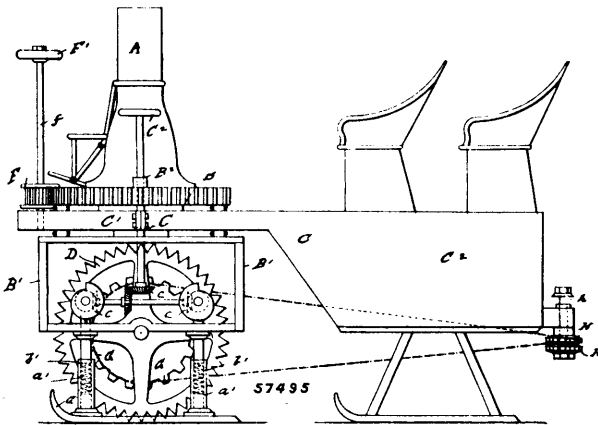

Thomas L. Rankin, Sackett's Harbour, New York, U.S.A., 20th September, 1897; 6 years. (Filed 1st September, 1897.)

*Claim.*—1st. In a motor-sled, combination of runners *a a*, provided with upwardly-extending hollow posts, having springs *a<sup>1</sup>, a<sup>1</sup>* therein, and a sled-body provided with legs *b<sup>1</sup>, b<sup>1</sup>*, resting within said posts and bearing against said springs, and means for adjusting the pressure on said springs, substantially as described. 2nd. In a motor-sled, the combination of runners *a a*, provided with upwardly-extending hollow posts *a<sup>1</sup>, a<sup>1</sup>*, springs within said posts, a sled-body *C* having downwardly-extending legs *b<sup>1</sup>, b<sup>1</sup>*, within said posts bearing on said springs, and cams *c c* actuated by gearing *c<sup>1</sup>*, having rod connection with a handle *w*, substantially as and for the purposes hereinbefore set forth. 3rd. In a motor-sled, the combination of runners and legs connecting with the body of the sled made adjustable as to height, a turn-table *B* secured above the frame of said sled, a king-bolt *C<sup>1</sup>* connecting the same therewith, and gearing for operating said turn-table, said gearing being connected by a rod with a hand-wheel, whereby the sled may be steered, substantially as and for the purposes hereinbefore set forth. 4th. A motor-sled having a motor for furnishing power, in combination with driving-wheels impelled thereby, adjustable runners, and means for guiding and steering said sled, substantially as and for the purposes hereinbefore set forth. 5th. In a motor-sled, the combination of runners *a a*, provided with an adjustable connection with the body of the sled, and detachable shoes *O* adapted to receive said runners and afford a broad surface for passing over deep snow, substantially as and for the purposes hereinbefore set forth. 6th. In a motor-sled, the combination of adjustable runners *a a* and means for regulating the height of the body of the sled therefrom, and one or more drums secured to said sled and provided with flat surfaces for passing over deep snow, substantially as described. 7th. In a motor-sled, means for guiding and steering the same, runners and connections for adjusting the height of the body of the sled, and one or more drums having spring wings for coming in contact with the snow or ice, said wings being adapted to fold as the drum revolves, substantially as and for the purposes hereinbefore set forth. 8th. In a motor-sled, means for guiding and steering the same, one or more drums having flat surfaces arranged to project from the periphery thereof, and be depressed by the weight thereon, as the drums revolve, substantially as and for the purposes hereinbefore set forth. 9th. In a motor-sled, a lead wheel and connections for imparting motion from the motor thereto, said lead wheel being provided with cogs or teeth on its periphery, and means for raising and lowering the same, substantially as and for the purposes hereinbefore set forth. 10th. In a motor-sled, the combination of a lead wheel having connections for receiving power from a motor on said sled, said lead wheel being journalled on shafts trunnioned to the body of the sled, said shaft being extended beyond said trunnions, a winding winch having cable connections with the ends of said shafts for increasing or relieving the pressure upon said lead wheels, substantially as and for the purposes hereinbefore set forth.

**No. 57,496. Boiler Furnace.** (*Fournaise de chaudières.*)

Albert Franklin Kingsley, Washington, Columbia, U.S.A., 20th September, 1897; 6 years. (Filed 3rd September, 1897.)

*Claim.*—1st. The combination with the flues and fire box of a boiler furnace, of three or more water boxes, a series of fireclay cross pieces resting upon and supported by said water bars, each cross piece being composed of sections each of which is supported by two water bars only, and a series of air conduits formed each of tubular laterally perforated sections put together end to end, said sectional cross pieces and air conduits being provided with recesses and engaging shoulders whereby they are interlocked, the one serving to hold the other properly spaced and in place, whereby said parts are caused to form an air grating, which is articulated o

jointed both lengthwise and crosswise, substantially as and for the purpose hereinbefore set forth. 2nd. The air conduit composed of

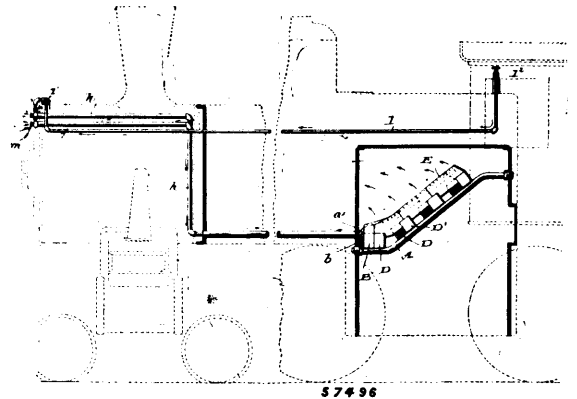

sections whose abutting ends meet in a ball and socket joint as described in combination with the sectional cross pieces having locking recesses or shoulders to interlock with corresponding recesses and shoulders on the air conduit sections, and a series of three or more water bars upon which the sections of the cross pieces are placed in such manner that each section of each cross piece shall be supported by two water bars only. 3rd. In combination with the air grating, and the fire box, smoke box and boiler flues of a locomotive, the air pipes *b* extending from the front and upper part of the head of the locomotive down through the smoke box and in front of the flue head, to those flues through which air is conducted to the air grating, an injector for each pipe, and a steam supply pipe, connected to said injectors and controlled by a valve or cock in the locomotive cab or at some other point convenient to the engineer or fireman, substantially as and for the purposes hereinbefore set forth.

**No. 57,497. Bottle Stopper.** (*Bouchon de bouteille.*)

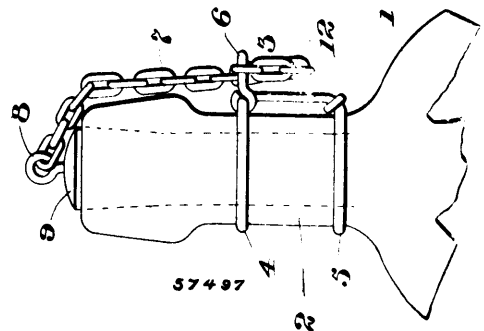

William Haskins, Troy, New York, U. S. A., 20th September, 1897; 6 years. (Filed 6th September, 1897.)

*Claim.*—1st. The combination with a bottle neck, of a single piece of wire bent to form loops 4 and 5, being adapted to fit over the neck of the bottle, a chain secured to the loop 6 at one end, and having its other end connected to the eye on the top of the bottle-stopper, substantially as and for the purpose set forth. 2nd. The combination with the bottle neck, of a weighted stopper therein, provided at its upper side with an eye, a chain connected to said eye, and having its other end connected with a loop 6, loops 4 and 5 formed of a continuation of the wire forming loop 6, said loops 4 and 5 being adapted to fit over the neck of the bottle, substantially as and for the purpose set forth.

**No. 57,498. Car Replacer.**

(*Appareil à remettre les chars sur la voie.*)

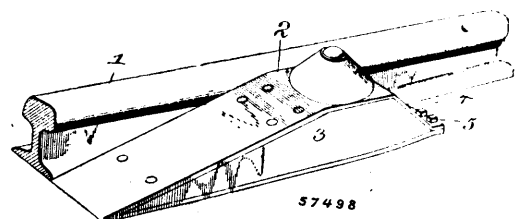

Levi W. Olmstead, Galeton, Pennsylvania, U.S.A., 20th September, 1897; 6 years. (Filed 6th September, 1897.)

*Claim.*—1st. A car replacer comprising a block adapted to raise the wheels above the level of the track, and a roller rotatively secured to said block, adapted to guide the wheels laterally and replace them upon the rails, substantially as described. 2nd. A car replacer comprising a wedge-shaped block adapted to guide and elevate the wheels above the level of the rails, said block being bevelled at one end, and a conical roller rotatively secured to the said block to guide the wheels laterally, substantially as described. 3rd. A car replacer comprising a wedge-shaped block having a flattened upper portion and a bevelled end adjacent thereto, a metal covering provided with a perforated projection, bolts engaging said perforated projection to secure the covering in place, and a conical roller rotatively secured to said block and adapted to guide the wheels laterally, substantially as and for the purposes described. 4th. A car replacer comprising a wedge-shaped block formed with a flattened upper portion and a bevelled end, a metal covering secured to said block, spikes or projections arranged upon the under side of said block, and a bevelled roller adapted to give lateral movement to the wheels when they contact therewith, substantially as described.

**No. 57,499. Upholstering Pin.**  
(*Aiguille pour tapisseries.*)

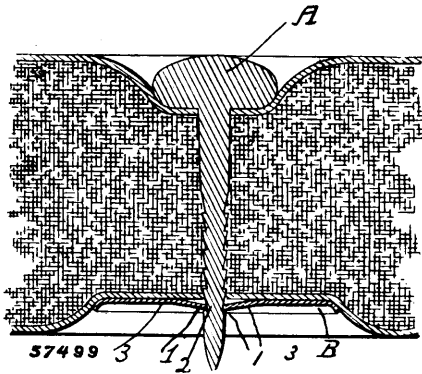

George Humphrey Howell, Sioux City, Iowa, and Carl Raab, New York, State of New York, both in the U.S.A., 20th September, 1897; 6 years. (Filed 31st August, 1897.)

*Claim.*—1st. The combination with a pin having a pointed end adapted to penetrate and find its way through the material to be fastened, of a plate or disc having a hole extending therethrough wherein to receive the pin, and also provided with several slits extending radially from the hole whereby to form lips or spring-jaws to engage the pin, substantially as set forth. 2nd. In upholsterers' buttons, the bottom, the shank, the notches, barbs, serrations, threads or roughened portions at 1, and the catch B, with its central perforation and the points, between the slits, substantially as set forth. 3rd. In upholsterers' appliances the button, its elongated shank in combination with the catch B, with its perforation and its spring clutching-points substantially as set forth. 4th. The combination with the notched, serrated or threaded shank of an upholstering pin, of a locking catch or disc dished at its centre and having radiating slits in said dished portion, whereby to form lips to engage said serrated shank, substantially as set forth. 5th. The combination with the notched, serrated or threaded shank of an upholstering pin, of a locking catch or disc having lips to engage said shank and having its periphery bent downwardly, substantially as set forth.

**No. 57,500. Nut Lock.** (*Arrête-écrou.*)

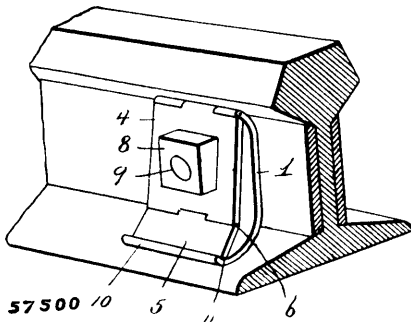

Isaac Hosier, Philmont, New York, U.S.A., 21st September, 1897; 6 years. (Filed 6th September, 1897.)

*Claim.*—1st. In a nut lock, the combination with a spring plate curved longitudinally and provided with a bolt aperture and with a flange at one end, of a locking plate composed of a pair of jointed sections hinged to said spring plate, substantially as described. 2nd.

In a nut lock, the combination with a spring plate provided with a bolt aperture and with an inturned flange extending across one end thereof, of a locking plate provided with a nut aperture coincident with the bolt aperture in the spring plate, said locking plate being composed of a pair of jointed sections, one of said sections being hinged to the end of the spring plate opposite the flange, and the free end of the other section of the locking plate being designed to engage said flange, substantially as described.

**No. 57,501. Folding Hay-Rake.** (*Râteau à foin pliant.*)

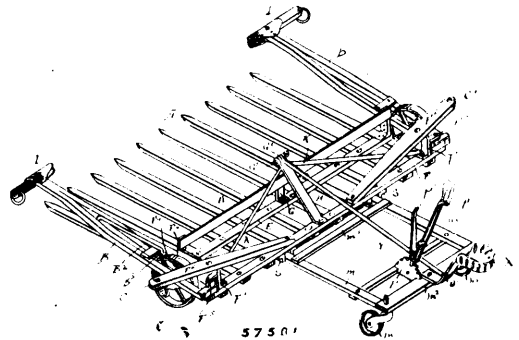

Aaron Stanton, Valparaiso, Indiana, U.S.A., 21st September, 1897; 6 years. (Filed 4th September, 1897.)

*Claim.*—1st. In a folding hay-rake, the rake-head, the swinging half tongues each mounted upon a wheel, each pivotally hinged to the head, the rear frame detachably hinged to the rake-head, the ratchet and ratchet-lever having a grip-lever and catch mounted thereon the grip and rod N to raise or depress the teeth. 2nd. In a folding rake, the teeth, the half tongues separately mounted upon a wheel and pivotally attached on each side of the rake, each tongue being detachably held by a pin through the jaw F<sup>o</sup> each adapted to swing outward and to swing upon a line at right angles to the teeth in combination with the brace B<sup>2</sup> to hold one of said half-tongues while the other is free, to move upon its pivotal attachment. 3rd. In a folding rake, the transverse bars, the teeth, the half tongues, each mounted upon a wheel, each pivotally attached on each side of the machine, each detachably held by the jaws F<sup>o</sup>, each arranged when released to swing outward and to stand upon a line at right angles to its first position, in combination with the frame m m, m<sup>2</sup>, m<sup>3</sup> arranged to be detached, and to be reattached under the teeth of the rake for passing along an ordinary country roadway. 4th. In a folding hay-rake, the rake-head, the rear frame detachably hinged to the rake-head and mounted on casters carrying a ratchet-lever, the rod N its forward extremity attached to the rake-head, the grip lever and latch said grip being pierced to receive the rod N, and permit the same to move freely therein when the grip lever is latched and to engage and rigidly hold the rod when the lever is released from the latch.

**No. 57,502. Motor Cradle and Buggy.**  
(*Moteur pour berceaux et voitures d'enfants.*)

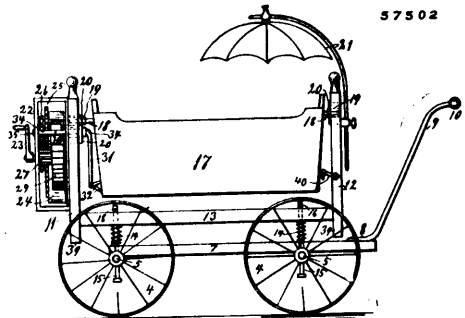
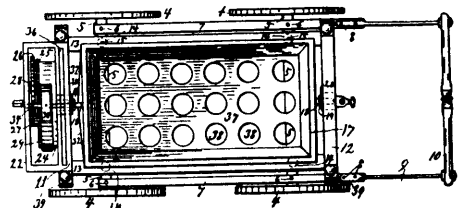

Carl Frederick Nilson, Hurley, Wisconsin, U.S.A., 21st September, 1897; 6 years. (Filed 4th September, 1897.)

*Claim.*—1st. The combination with a wheeled skeleton truck having the handle 9, 10 of a frame detachably supported on springs upon the truck, a cradle suspended within the frame and being adapted to rock in the frame whether the latter is on the truck or not, substantially as and for the purpose set forth. 2nd. The combination with a wheeled truck having handhold for pushing it by, of a cradle suspended and rocking or swinging in a frame having legs adapted to stand on the floor and a motor secured to said frame for swinging the cradle and means for yieldingly and detachably supporting said motor and frame upon the truck, substantially as and for the purpose set forth. 3rd. In a cradle, the combination of a frame and a cradle supported on trunnions to rock or swing therein, of a clock-work motor secured to one end of the frame and operatively connected with the cradle and a parasol secured to the opposite end of the cradle over the head of the child, substantially as and for the purpose set forth. 4th. In a cradle, the combination with a supporting frame of a cradle swinging therein on trunnions or journals, a motor secured to one end of the frame and operating the cradle, said motor having the escapement-wheel 29, and the anchor 30, rock shaft 34, and pendulum arm 31, and flexible connection between said arm and the cradle proper, substantially as and for the purpose set forth. 5th. In a cradle, the combination with a supporting frame, of a cradle swinging therein on trunnions or journals, a motor secured to one end of the frame and operating the cradle, said motor having the escapement-wheel 29, and the anchor 30, rock shaft 34, and pendulum arm 31, and flexible connection between said arm and the cradle proper, said escapement-wheel being made of rubber or other sound-deadening materials, substantially as and for the purpose set forth. 6th. In a cradle, the combination with a supporting frame of a cradle swinging therein on trunnions or journals, a motor secured to one end of the frame and operating the cradle, said motor having the escapement-wheel 29, and the anchor 30, rock shaft 34, and pendulum arm 31, and flexible connection between said arm and the cradle proper, said trunnions and rock shaft having their journal boxes inserted in rubber secured in the framework, substantially as and for the purpose set forth. 7th. In a cradle, the combination with a supporting frame of a cradle swinging therein on trunnions or journals, a motor secured to one end of the frame and operating the cradle, said motor having the escapement-wheel 29, and the anchor 30, rock shaft 34, the pendulum arm 31, and flexible connection between said arm and the cradle proper, said trunnions and rock shaft having their journal boxes inserted in rubber secured in the framework, and the case containing said motor being secured to the cradle supporting frame with an intervening dead-air space, substantially as and for the purpose set forth.

**No. 57,503. Cream Separator. (Séparateur pour la crème.)**

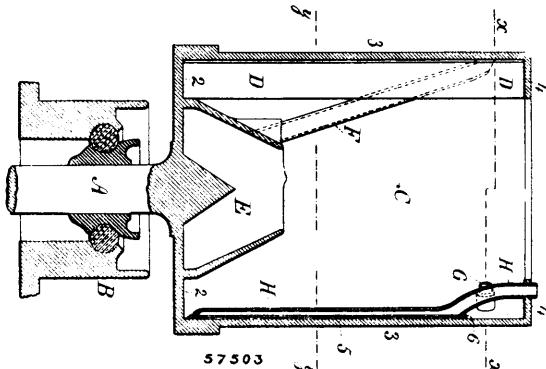

Thomas Collins and Ernest Louis Hartmann, both of Bambridge, New York, U.S.A., 21st September, 1897; 6 years. (Filed 3rd September, 1897.)

*Claim.*—1st. The combination with the cylindrical, centrifugal separator-bowl, of a skim-milk tube, with a long and thin opening between such tube and the interior surface of the bowl, substantially as set forth. 2nd. The combination with the cylindrical, centrifugal separator-bowl, of a skim-milk tube flattened and slotted longitudinally, the slot of the tube being closely adjacent to the interior surface of the cylindrical bowl, the lower end of the tube being closed, and the upper end of said tube passing through the rim at the top of the bowl, substantially as set forth. 3rd. The combination with the cylindrical, centrifugal separator-bowl, of a skim-milk tube with a long and thin opening between the tube and the interior surface of the bowl, a wing within the bowl, a receiving-cup in the bottom of the bowl, and a tube from the same leading up to the interior surface of the bowl near the upper end thereof, substantially as set forth. 4th. The combination with the centrifugal bowl, of a skim-milk tube having an edge closely adjacent to the interior and substantially cylindrical portion of the bowl for allowing the skim milk to pass in a thin layer between such edge and the bowl, substantially as specified.

**No. 57,504. Fastening Device. (Attache.)**

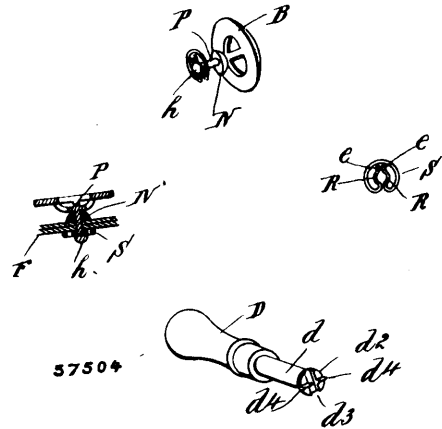

Paul Goldsmith, Troy, New York, U.S.A., 21st September, 1897; 6 years. (Filed 3rd September, 1897.)

*Claim.*—1st. A fastening device or attachment, consisting of a plate or button, a pin connected therewith, and provided with a head, said pin being adapted to be passed through the material or fabric to be connected or fastened together, and a keeper composed of a spring wire bent circularly, and the ends of which are bent transversely thereof, and provided with spring jaws which are adapted to be passed over the head of the pin, substantially as shown and described. 2nd. A fastening device or attachment, consisting of a plate or button, a pin connected therewith and provided with a head, said pin being adapted to be passed through the material or fabric to be connected or fastened together, and a keeper composed of spring wire bent circularly, and the ends of which are bent transversely thereof, and provided with spring jaws which are adapted to be passed over the head of the pin, said pin being also provided with a washer which is mounted thereon, substantially as shown and described. 3rd. A fastening device, consisting of a plate or button, a pin connected therewith and provided with a head which is adapted to receive a spring keeper, and a threading needle which is adapted to be connected with the said pin, and by means of which said pin is adapted to be passed through a garment, fabric or other articles, substantially as shown and described. 4th. A fastening device consisting of a plate or button, a pin connected therewith and provided with a head which is adapted to receive a spring keeper, and a threading needle which is adapted to be connected with the said pin, and by means of which said pin is adapted to be passed through a garment, fabric or other articles, said pin being also provided with a washer, substantially as shown and described.

**No. 57,505. Portière Rod. (Baguette de portière.)**

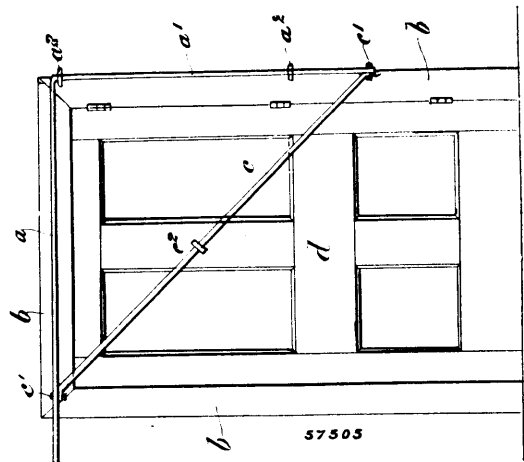

James Aitchison, Dunedin, Otaga, New Zealand, 21st September, 1897; 6 years. (Filed 2nd September, 1897.)

*Claim.*—1st. A portière rod, consisting of a horizontal and vertical portions hinged at a distance from the hinges of the door, and a diagonal bar passing through and sliding within an eyebolt or bracket fixed to the door, substantially as and for the purposes set forth herein. 2nd. The improvements in and relating to portière rods, consisting of parts constructed, arranged and operating substantially as and for the purposes set forth herein.

**No. 57,506. Bedstead Lock.** (*Serrure de lit.*)

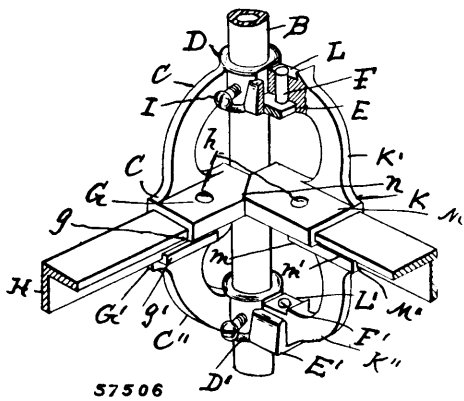

The R. H. Smith Co., assignee of Thomas James Sear, both of St. Catharines, Ontario, Canada, 21st September, 1897; 18 years; (Filed 1st September, 1897.)

*Claim.*—1st. In a bedstead lock, a seat piece C, comprising the following elements, branching arms C, C', carrying collars D, D', perforated to receive a set-screw, recessed seats E, E', carrying locking pins F, F', lipped ledges G, G', mitred at  $n$ , with lips  $g$ ,  $g'$ , respectively, substantially as specified. 2nd. In a bedstead lock, reversible locking piece K, comprising the following elements, branching arms K', K'', carrying perforated blocks L, L', lipped ledges M, M', mitred at  $n$ , with lips  $m$ ,  $m'$ , respectively, substantially as specified. 3rd. The combination with the bedstead pillar B, of the seat piece C, provided with branching arms C', collars D, D', recessed seats E, E', locking pins F, F', and lipped ledges G, G', adapted to hold the end rail H, the set-screw I, passing through the collar to bind it to the pillar, and the reversible locking piece K, provided with branching arms K', K'', perforated blocks L, L', to fit on the locking pins F, F', in the recessed seats E, E', and the lipped ledges M, M', adapted to hold the side rail N, substantially as specified. 4th. The combination with the bedstead pillar B, of the seat piece C, provided with branching arms C', collars D, D', recessed seats E, E', locking pins F, F', and ledges G, G', with dovetailed lips and rivet to hold the end rail H, the ledge G, being mitred at  $n$ , the set screw I passing through the collar to bind it to the pillar, and the reversible locking piece K, provided with branching arms K', K'', perforated blocks L, L', to fit on the locking pins F, F', and the ledges M, M', with dovetailed lips and rivet to hold the side rail N, the ledge N, being mitred at  $n$ , to fit against the corresponding mitre on the ledge G, substantially as specified.

**No. 57,507. Car Coupler.** (*Attelage de chars.*)

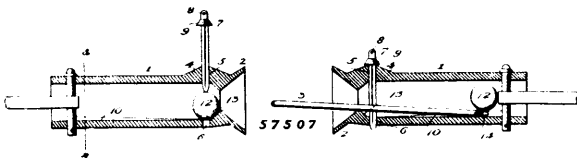

Leon Joseph Yarnell and Joseph Henry Schmidt, both of Deepwater, Texas, U.S.A., 21st September, 1897; 6 years. (Filed 7th September, 1897.)

*Claim.*—1st. A car coupling comprising the draw-head 1, provided with the integral boss 4 having a vertical rectangular orifice 5, an aligned orifice 6, and a contiguous shoulder 13 in the bottom of said draw-head, in combination with the ball 12, the rectangular coupling pin 7, and the link 3 provided with a longitudinal projecting bevel edged toe 14, substantially as shown and described. 2nd. A car coupling comprising the draw-head 1, provided with the integral boss 4 having the vertical rectangular orifice 5, an aligned orifice 6, a contiguous transverse shoulder 13, and the parallel forwardly inclined rails 10, 10, in the bottom of said draw-head, in combination with the rectangular projecting coupling pin 7, and the link 3, provided with the forwardly projecting bevel edged toe 14, substantially as shown and described.

**No. 57,508. Voting Machine.** (*Machine à voter.*)

Patrick Anderson Macdonald, Winnipeg, Manitoba, Canada, 21st September, 1897; 6 years. (Filed 26th February, 1897.)

*Claim.*—1st. A voting machine comprising an inclined tube, a partition screen intermediately supporting the tube, balls for depositing in the branch tubes, and receiving and registering mechanism in the branch tubes for recording the number of balls deposited in each tube, as and for the purpose specified. 2nd. A voting machine comprising an inclined tube, a partition screen intermediately sup-

porting the tube, a T-shaped upper end joint for the tube, branch tubes having T-shaped lower ends designed to be inserted into the

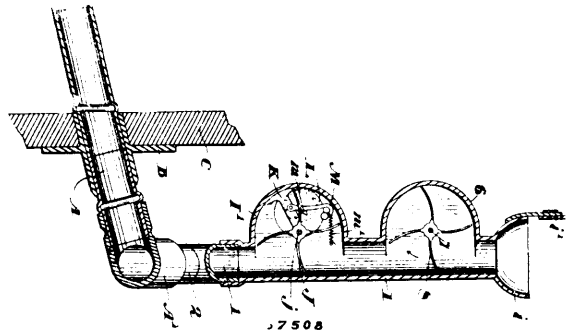

joint and each other, balls for depositing in such tubes and receiving and registering mechanism operated by the balls, as and for the purpose specified. 3rd. A voting machine comprising an inclined tube, a partition screen intermediately supporting the tube, a T-shaped upper end joint for the tube, branch tubes having T-shaped lower ends designed to be inserted into the joint and each other, balls for depositing in such tubes, and receiving and registering mechanism operated by the balls and caps for closing the extreme ends of the T-shaped lower ends of the branch tubes, as and for the purpose specified. 4th. A voting machine comprising an inclined tube, a partition screen intermediately supporting the tube, a T-shaped upper end joint for the tube, branch tubes having T-shaped lower ends designed to be inserted into the joint and each other, balls for depositing in such tubes and receiving and registering mechanism operated by the balls, caps for closing the extreme ends of the T-shaped lower ends of the branch tubes and a connecting chain for the caps having one end extending through a slot in one cap, and a padlock for the end projecting link, as and for the purpose specified. 5th. The combination with the main tube and intermediate screen supporting the same, branch tubes connected to the upper end of the main tube, the controlling rotating wings for each branch tube suitably journaled in enlargements of the tube and designed to have one wing normally extending into the tube, and independent means for controlling the rotation of said wings, as and for the purpose specified. 6th. The combination with the main tube and intermediate screen supporting the same, branch tubes connected to the upper end of the main tube, the controlling rotating wings for each branch tube suitably journaled in enlargements of the tube and designed to have one wing normally extending into the tube, the rods to which the rotating wings are affixed, the central spindle journaled on suitable standards and provided with a pin wheel, universal joints between the ends of the spindle and the rods, a pin wheel journaled on a suitable standard on the opposite side of the screen and provided with a suitable handle and a band connecting both pin wheels, as and for the purpose specified. 7th. The combination with the main tube and intermediate screen supporting the same, branch tubes connected to the upper end of the main tube, the controlling rotating wings for each branch tube, suitably journaled in enlargements of the tube and designed to have a wing normally extending into the tube, independent means for controlling the rotation of said wings, the lower enlargements to the branch tubes, the rotating wings suitably journaled and designed to have one wing normally extending into the tube, a pinion on the ends of the arbors of the wings and registering wheel operated from such pinion, as and for the purpose specified. 8th. The combination with the main tube and intermediate screen supporting the same, branch tubes connected to the upper end of the main tube, the rotating wings for each branch tube, suitably journaled and designed to have one wing normally extending into the tube, a pinion on the end of the arbor of the wings and registering wheels operated from such pinion, a casing covering the registering wheels provided with a slot to expose the numbers, a cap for such casing and means for locking such cap in position, as and for the purpose specified. 10th. The combination with the main tube and intermediate screen supporting the same, of the branch tubes connected to the upper end of the main tube, the rotating wings for each branch tube suitably journaled and designed to have one wing normally extending into the tube, a pinion on the end of the arbor of the wings and registering wheels operated from such pinion, a casing covering the registering wheels provided with a slot to expose the numbers, a cap for such casing, a staple extending from the end of the casing through the slot in the cap, and a padlock for the staple, as and for the purpose specified. 11th. The combination with the main tube and intermediate screen supporting the same, of the branch tubes connected to the upper end of the main tube, the rotating wings for each branch tube suitably journaled and de-

signed to have one wing normally extending into the tube, a bell in the case and mechanism operated from the wings to strike the bell upon each depression of the wing in the tube, as and for the purpose specified. 12th. The combination with the main tube and intermediate screen supporting the same, of the branch tubes connected to the upper end of the main tube, the rotating wings for each branch tube suitably journaled and designed to have one wing normally extending into the tube, a bell in the casing, laterally extending pins from the wings, a hammer pivoted in proximity to the wings provided with a V-shaped projection and spring-held, as and for the purpose specified. 13th. In a voting machine comprising an inclined tube, a partition screen intermediately supporting the tube, balls for depositing in the branch tubes and receiving and registering mechanism in the branch tubes for recording the number of balls deposited in each tube, and a receptacle at the lower end of the tube, as and for the purpose specified.

**No. 57,509. Car Seal Lock. (Serrure à sceau pour chars.)**

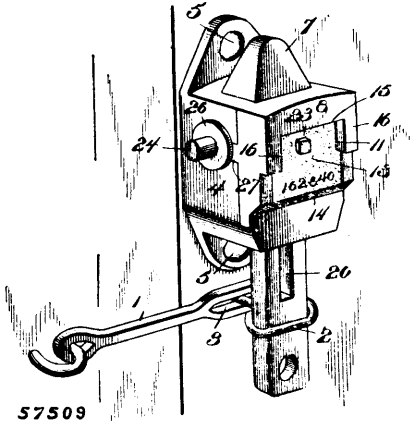

57509

William K. Edgar, Colorado Springs, Colorado, U.S.A., 21st September, 1897; 6 years. (Filed 1st September, 1897.)

*Claim.*—1st. In a seal-lock, the combination with a casing provided with a bolt-guide and a seal-seat, of a slotted bolt, the slot thereof having a terminal enlargement, a locking-pin mounted for movement in a guide arranged in a plane transverse to the bolt and extending through the enlargement of the slot therein, said locking-pin having a reduced portion or neck adapted to be received by the reduced portion of the slot in the bolt to allow longitudinal movement of the latter, and means for securing the locking-pin with its body portion in engagement with the enlargement of the slot, in the bolt, substantially as specified. 2nd. In a seal-lock, the combination with a casing having a bolt-guide and a parallel seal-seat, of a slotted bolt fitted in said guide, the slot therein having a terminal enlargement, a locking-pin mounted in a guide disposed transversely with relation to the bolt-guide and extending through the enlargement of the slot in the bolt, said pin having a reduced portion of the slot in the bolt, a seal fitted in said seat and having an opening adapted to receive the front end of the locking-pin, and means for securing the locking-pin in its normal position, substantially as specified. 3rd. In a seal-lock, the combination with a locking-bolt and seal having an opening, of a locking-pin mounted for movement transversely to the bolt and adapted when extended to engage said bolt and seal, the locking-pin being provided with a ratchet, a pawl yieldingly held in operative relation with the ratchet of the locking-pin to secure the latter in its advanced position, and a trip or releasing pin, having a bevelled face arranged inoperative relation with the pawl, and a stem disposed contiguous to and adapted to be concealed by the seal, substantially as specified. 4th. In a seal-lock, the combination with a casing having a bolt-guide and a parallel seal-seat, the latter being cut away to form a cavity, a seal fitted in said seat to cover the cavity, and a bolt mounted in the bolt-guide, of a locking-pin mounted in a guide disposed transversely with relation to the bolt-guide and adapted when extended or advanced to engage the bolt and seal, said pin extending through the cavity of the seal-seat, means for locking the pin in its advanced position, and a trip or releasing pin, arranged in operative relation with the locking devices of the pin, and having a stem projecting terminally into said cavity of the seat, and provided with a ring, adapted to be arranged in the cavity around the locking-pin when the seal is secured by the latter, substantially as specified. 5th. In a seal-lock, the combination with a casing having a bolt-guide and seal-seat, a bolt mounted in said guide, and a seal fitted in the seat, of a locking-pin mounted for movement transversely with relation to the bolt and adapted when in its extended or advanced position to engage both bolt and seal, an operating-pin projecting laterally from the locking-pin and extending through a slot in the side of the casing, whereby it is terminally accessible from the exterior of the casing, means for locking the pin in its advanced position, and trip devices including a stem terminally concealed by the seal, substantially as specified.

**No. 57,510. Furnace. (Fournaise.)**

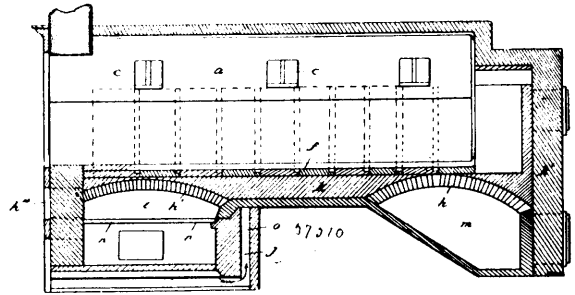

William Henry Peck and David Reid Wilson Patterson, both of Pittsburgh, Pennsylvania, U.S.A., 21st September, 1897; 6 years. (Filed 6th September, 1897.)

*Claim.*—1st. In a furnace, a semicircular casing formed in sections overlapping each other and supported by a lug or flange engaging in the side wall, said lug or flange extending in close proximity to the boiler shell to hold the casing in position, substantially as shown and described. 2nd. In a furnace, the casing around the boiler, arched walls, partitions and side walls for supporting the same, said partitions forming throats or passage-ways, and a series of air inlets to the said throats to complete the combustion, substantially as shown and described. 3rd. In a furnace, the boiler provided with a casing, supported by side walls, partitions arranged underneath said casing to form passage-ways from the combustion chamber, a series of air flues or ducts leading to said passage-ways, and arched walls over the combustion chamber and retort, reducing the smoke to a gas before the same reaches the flues, substantially as shown and described. 4th. In a furnace, the boiler thereof provided with a casing supported in close proximity to the boiler shell and adapted to retain the heat from the furnace to assist the combustion, substantially as shown and described. 5th. In a furnace, a casing supported in close proximity to the boiler, a series of partitions underneath the casing to form throats or passage-ways from the combustion chamber, substantially as shown and described. 6th. In a furnace, a casing, partitions arranged underneath the casing and forming throats or passage ways from the combustion chamber, air flues or ducts leading to said passage-ways, the combination serving to reduce the smoke to a gas before the same reaches the flues of the boiler, substantially as shown and described. 7th. In a furnace, the combination of the casing arranged around the boiler shell, partitions arranged underneath said casing, and air ducts communicating with the throats or passage-ways formed by the partitions, and thereby forming means for reducing the smoke to a gas before the same reaches the flues, and for reducing the temperature of the gases at the uptake, substantially as shown and described.

**No. 57,511. Fire Escape. (Sauveteur d'incendie.)**

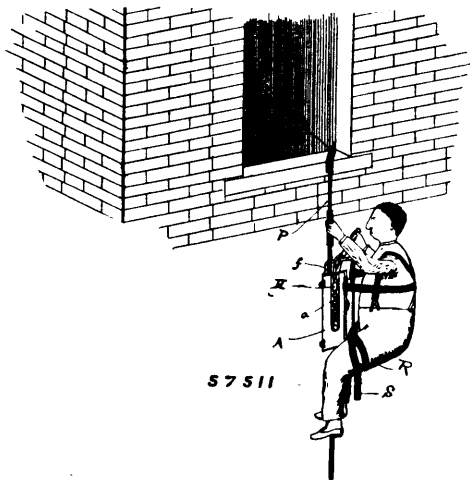

Hans Frahen, Bemson, Nebraska, U.S.A., 21st September, 1897; 6 years. (Filed 6th September, 1897.)

*Claim.*—1st. A fire-escape comprising the side bars, rollers mounted therein, a pressure-block bearing on the shaft of the upper roller, and an eccentric acting on said block, a lever connected with the eccentric, and means for holding the same in its adjusted position, substantially as described. 2nd. The combination of the side bars and the straps secured thereto, of the rope-guides held between the side bars, the rollers mounted in grooves in said side bars, the rope passed through the rope-guides and around said

rollers, a bearing block acting upon the shaft of the upper roller, and an eccentric acting on said block, and a lever connected with said eccentric and having a notched plate and a pivoted pawl adapted to engage said plate, as described. 3rd. The combination of the grooved side plate and the rollers having their shafts mounted in said grooves, of the bearing block acting on the shaft of the upper roller, the eccentric mounted to act on said block, and a removable wedge adapted to be inserted above said block, substantially as described. 4th. The combination with the grooved side plate and the rollers having their shafts mounted in said grooves, of the bearing block acting on the shaft of the upper roller, the eccentric mounted to act on said block, and a removable wedge adapted to be inserted above said block, an arm extending from the eccentric, and a lever pivotally connected with said arm, substantially as described. 5th. The combination with the grooved side plates and the rollers having their shafts mounted in said grooves, of the bearing block acting on the shaft of the upper roller, the eccentric mounted to act on said block, and a removable wedge adapted to be inserted above said block, an arm extending from the eccentric, a notched plate on said lever, and a pawl pivoted to one of the side bars and having a notched end engaging said plate, substantially as described. 6th. The combination with the grooved side plates and the rollers having their shafts mounted in said grooves, of the bearing block acting on the shaft of the upper roller, the eccentric mounted to act on said block, and a removable wedge adapted to be inserted above said block, an arm extending from the eccentric, and a lever pivotally connected with said arm, a notched plate on said lever, and a pawl pivoted to one of the side bars and having a notched end engaging said plate, the upper and lower rope-guides, the straps secured to the side bars, and the rope passed through the rope-guides and around the rollers, substantially as described. 7th. The combination with the grooved side plates and the rollers having their shafts mounted in said grooves, of the bearing block acting on the shaft of the upper roller, the eccentric mounted to act on said block, and a removable wedge adapted to be inserted above said block, an arm extending from the eccentric, and a lever pivotally connected with said arm, a notched plate on said lever, and a pawl pivoted to one of the side bars and having a notched end engaging said plate, the upper and lower rope-guides, the straps secured to the side bars, and the rope passed through the rope-guides and around the rollers, and a removable wedge adapted to be inserted above the bearing block, substantially as described.

**No. 57,512. Bottle and Stopper. (Bouteille et bouchon.)**

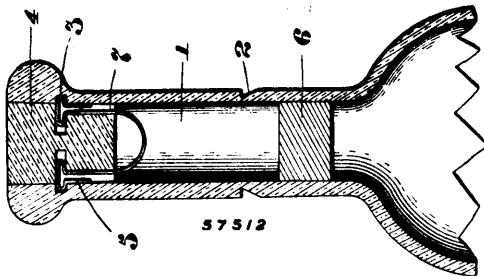

Holmes Wass Coffin, Addison, Maine, U.S.A., 21st September, 1897; 6 years. (Filed 6th September, 1897.)

*Claim.*—1st. The combination of a bottle having a groove or crease around the outside of the neck, and a shoulder or notch around the inside of the neck, with a hard stopper and means for locking the hard stopper in the neck of the bottle, substantially as described. 2nd. The combination of a hard stopper provided with recesses, a bottle provided with a groove or shoulder near its mouth, and a spring locking device having its extremities formed in a shape substantially as shown and described.

**No. 57,513. Non-refillable Bottle.**

(Appareil pour empêcher le remplissage des bouteilles.)

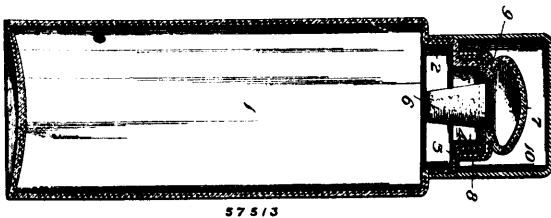

Edwin Blain Malchor, Los Angeles, California, U.S.A., 21st September, 1897; 6 years. (Filed 7th September, 1897.)

*Claim.*—1st. As an improved article of manufacture, a bottle, the neck of which is provided with a threaded collar 4 in combination with a threaded cap 7, formed with an external annular recess 9, substantially as shown and described. 2nd. As an improved article

of manufacture, a bottle, the neck of which is formed with a threaded collar 2, an annular flange 3, a smaller collar 4, and a removable cork stopper, in combination with threaded fragile cap 7, having the external annular recess 9 and the threaded metal cover, 10, substantially as shown and described.

**No. 57,514. Match Safe. (Garde-allumettes.)**

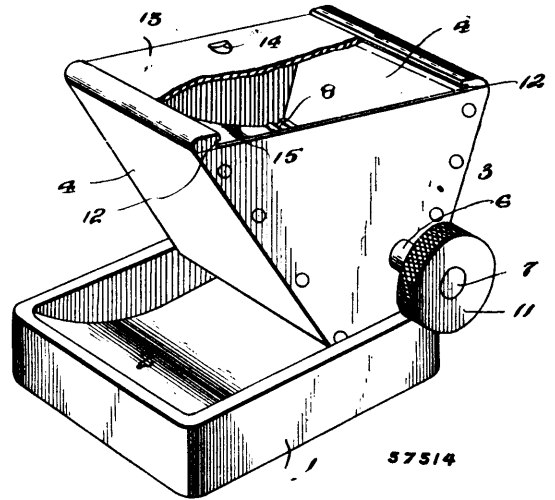

Isaac Hosier, Philmont, New York, U.S.A., 21st September, 1897; 6 years. (Filed 6th September, 1897.)

*Claim.*—1st. In a match safe, the combination with a hopper, of ejecting mechanism, and a spring plate arranged within the hopper and forming an inclined bottom therefor, substantially as described. 2nd. In a match safe, a hopper having downwardly converging walls, an ejection cylinder arranged in the base of the hopper, a receptacle beneath the hopper, and a spring plate within the hopper secured at one edge to a fixed point and bearing at its free edge against the periphery of the cylinder, substantially as and for the purposes described. 3rd. In a match safe, the combination with a recessed base forming a receptacle and having one wall chamfered or beveled as described, of a hopper secured to said base and arranged at one end thereof and comprising downwardly converging walls, one of which is concaved upon its inner side, side walls to said hopper provided with transversely aligned openings, an ejecting cylinder arranged within the hopper and having its ends reduced and fitted in said openings, means whereby said cylinder may be rotated, the said cylinder being provided with a longitudinal groove in its periphery, a lid for said hopper, and an inclined spring plate arranged within the hopper and attached at one edge within the hopper and having its free edge arranged to bear against the periphery of the cylinder and cooperate with the groove in the cylinder, substantially as and for the purpose specified.

**No. 57,715. Snow Plough. (Charrue à neige.)**

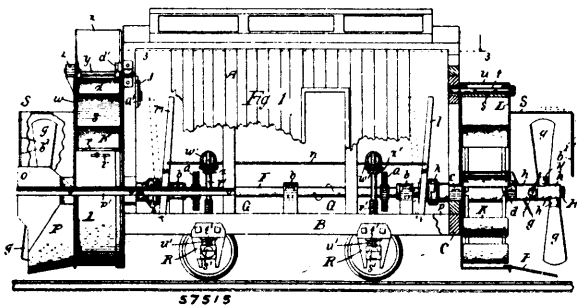

George W. Ruggles, Charlotte, New York, U.S.A., 21st September, 1897; 6 years. (Filed 2nd September, 1897.)

*Claim.*—1st. A track cleaner comprising a car adapted to move upon a railway, having a central, rotatory driving shaft, and other shafts at either end of the driving shaft, and couplings for connecting the driving shaft with said end shafts, and means, as a tie rod 7, for throwing the coupling at either end of the driving shaft into engagement with the adjacent end shaft and simultaneously disconnecting the coupling at the other end of the driving shaft, substantially as and for the purpose specified. 2nd. A snow plough consisting of a car having a longitudinal, rotatory shaft projecting at the end of the car and provided with a wheel and a series of blades for moving the snow, a housing for said wheel, with delivery openings for the snow at either side of the housing, and a shiftable chute



within the housing, over the wheel, for guiding the moving snow out at said openings, in combination with deflectors for the snow, outside of the housing, substantially as and for the purpose specified. 3rd. A snow plough consisting of a car having a longitudinal, rotatory shaft projecting at the end of the car and provided with a wheel without the car, and a hub on the shaft having a series of radial thimbles or holders projecting therefrom, the outer face of each of which is provided with a series of diametrically oppositely arranged notches, a series of blades each provided with diametrically oppositely arranged stops to engage with either set of said notches adapted to rest in a thimble or bearing of said hub, and a cap over the end of each thimble, substantially as shown and described. 4th. A snow plough comprising a car having its axles journalled in extended jaws, a central, rotatory, longitudinal driving shaft, and other shafts at either end of the driving shaft adapted to be turned by said central shaft, the end shafts projecting from the respective ends of the body of the car and each provided with devices for moving the snow, a screw through the car sill for raising or lowering the car, and a plate and a spring between the lower end of the screw and the axle bearing, substantially as and for the purpose set forth. 5th. A snow plough consisting of a car adapted to move along a railway, having a longitudinal, rotatory shaft projecting at the end of the car and provided with devices for moving the snow, a scoop carried by the car to co-act with said snow moving device, formed with upturned sides adapted to cut the snow, and stiffeners for said sides carried by the car body, substantially as specified. 6th. A track cleaner comprising a car adapted to move upon a railway, having a central longitudinal driving shaft, and other shafts at either end of the driving shaft adapted to be turned by the latter, said end shafts and the driving shaft being in a straight line, the end shafts projecting from the body of the car and each provided with wheels outside of the car for moving the snow, substantially as shown and described. 7th. A track cleaner consisting of a car having a central longitudinal driving shaft, and other shafts at the ends of the driving shaft adapted to be turned by the latter, said end shafts projecting at the respective ends of the car and each provided with a wheel outside of the car for moving the snow, and a series of blades outside of each wheel for acting upon the snow, in combination with hoods for covering said blades, provided with movable doors, in front of the blades, substantially as shown and described.

**No. 57,516. Sulky Plough. (Charrue à siège.)**

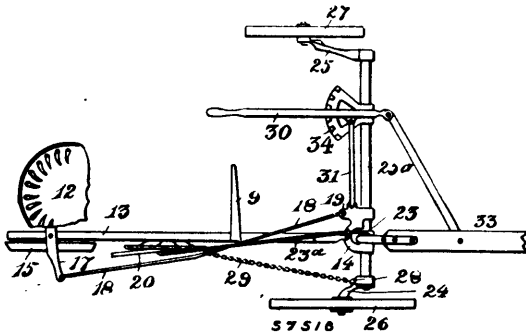

William Humphrey Perrin, Smith's Falls, Ontario, Canada, 21st September, 1897; 6 years. (Filed 31st August, 1897.)

*Claim.*—1st. In a sulky plough, the combination with the axle 25a, having depending arms on which the wheels are journalled, an arm 23 secured to the said axle, of the lever 20 fulcrumed on the plough beam which is attached to the said axle, a toothed segment secured to the said plough beam, a spring catch on the said lever and a rod connecting the said arm 23 with the said lever 20, above the fulcrum, substantially as set forth. 2nd. In a sulky plough, the combination with the axle 25a, having depending arms at the ends on which the wheels are journalled, an arm 23, secured to the said axle, a lever fulcrumed on the plough beam and attached to the said lever, a toothed segment and spring catch holding the said lever in any desired position, a rod connecting the said lever to the said arm 23, above the fulcrum, and a chain connecting the said lever below the fulcrum with a hook on the said axle, substantially as set forth. 3rd. In a sulky plough, the combination with the axle 25a on the depending arms of which the front wheels are journalled, of the tongue pivotally connected to the said axle, the lever 30 fulcrumed on a rod 31, a toothed segment adapted to be engaged by the said lever and secured to the said axle, and a brace rod 32, pivoted to the said lever below the fulcrum and to the tongue a short distance from its rear end, substantially as set forth. 4th. In a sulky plough, the combination with the plough beam pivotally secured to the front axle, carrying wheels on its depending ends and adapted to be partially revolved, of a follower wheel pivoted at the rear end of the said plough beam, an arm attached to the fork in which the said follower wheel is journalled, the said arm being at a right angle to the plough beam, a rod connecting this arm and the front axle, the said arm passing diagonally over the plough beam, substantially as set forth.

**No. 57,517. Ironing Machine. (Machine à repasser.)**

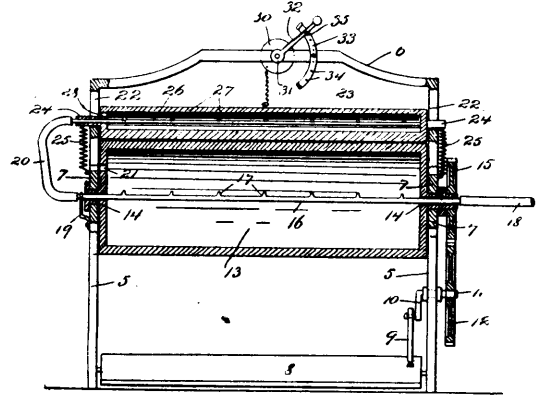

57517

Katharine Eliza Landan, New York, U.S.A., 21st September, 1897; 6 years. (Filed 30th August, 1897.)

*Claim.*—1st. An ironing machine comprising a suitable frame, a hollow roller mounted therein, a gas burner tube mounted in said roller, a pressure device mounted over said roller, and adapted to bear thereon, and provided with a gas burner tube which is mounted therein, and devices for supplying gas to said burner tubes and for revolving said roller, substantially as shown and described. 2nd. An ironing machine comprising a suitable frame, a hollow roller mounted therein, a gas burner tube mounted in said roller, a pressure device mounted over said roller and adapted to bear thereon, and provided with a gas burner tube which is mounted therein, and devices for supplying gas to said burner tubes and for revolving said roller, said pressure device being also provided with springs by which it is drawn downwardly in the direction of or upon said roller, substantially as shown or described. 3rd. An ironing machine comprising a suitable frame, a hollow roller mounted therein, a gas burner tube mounted in said roller, a pressure device mounted over said roller and adapted to bear thereon, and provided with a gas burner tube which is mounted therein, and devices for supplying gas to said burner tubes, and for revolving said roller said pressure device, being also provided with springs by which it is drawn downwardly in the direction of or upon said roller, and said pressure device being circular in cross section, substantially as shown and described. 4th. An ironing machine comprising a suitable frame, a hollow roller mounted therein, a gas burner tube mounted in said roller, a pressure device mounted over said roller and adapted to bear thereon, and provided with a gas burner tube which is mounted therein, and devices for supplying gas to said burner tubes and for revolving said roller, said pressure device being also provided with springs by which it is forced downwardly in the direction of or upon said roller, and said pressure device being circular in cross section, and the frame of the machine being provided at the top thereof with means for raising said pressure device, substantially as shown and described.

**No. 57,518. Treadle Power Sawing Machine. (Scierie à pedales.)**

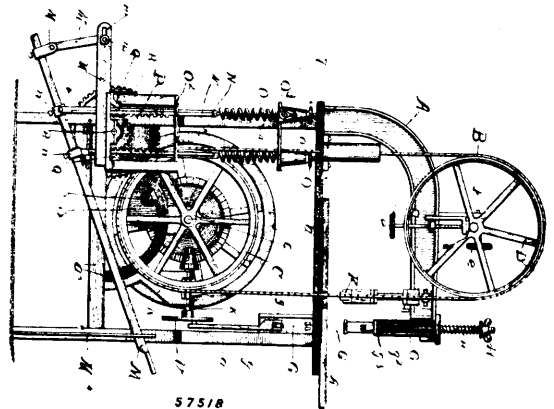

57518

William Hargrave, Chicago, Illinois, U.S.A., 21st September, 1897; 6 years. (Filed 28th August, 1897.)

*Claim.*—1st. In a machine of the character described, the combination, with the frame and its table, of the treadle, the racks connected thereto, the driving shaft operatively connected with the

racks, springs connected to the upper ends of the racks, and a bracket attached to the frame below the table carrying below said table the adjusting supports for the springs, substantially as set forth. 2nd. In a machine of the character described, the combination, with the frame, the driving shaft, and the spring-controlled racks operatively connected therewith, of a treadle connected with said racks and to the frame by a link at its rear end, and a guide secured to the frame and embracing the front portion of the treadle, substantially as set forth. 3rd. In a machine of the character described, the combination, with the treadle, the spring-controlled racks connected thereto, the driving shaft having loose pinions with pawls and fast ratchet wheels, the band wheel shaft connected therewith by suitable gearing, a bevel gear on said band wheel shaft, and a shaft provided with a pitman wheel and pitman to drive a jig saw and having an adjustable bevel pinion to engage said bevel gear, substantially as set forth.

**No. 57,519. Centrifugal Separator for Cream etc.**  
(*Séparateur centrifuge.*)

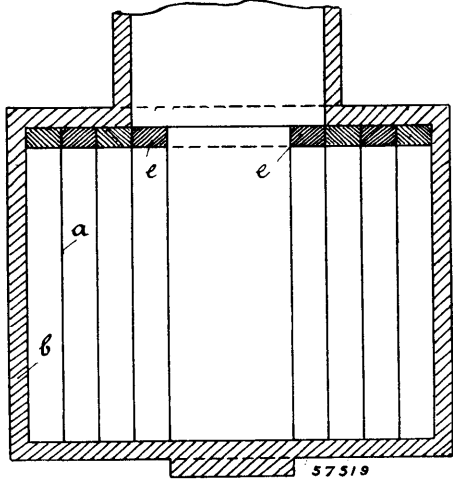

Thor. Ragnar Fornerhielm, Stockholm, Sweden, 21st September, 1897; 6 years. (Filed 27th August, 1897.)

*Claim.*—1st. The combination with a centrifugal separator vessel, of one or more division walls inside the said vessel in such a manner that the paths of the mass in relation to the vessel will be spirals for the purpose set forth. 2nd. The combination with a centrifugal separator vessel of one or more removable division walls placed inside said vessel in such manner that the mass to be separated will form and move in a spiral or spirals in relation to the vessel, or practically so, for the purpose set forth. 3rd. The combination with a centrifugal separator vessel, of a rolled plate provided with packing for keeping the different layers apart and for preventing the mass from passing the edge, substantially as and for the purpose set forth.

**No. 57,520. Maze or Labyrinth.** (*Labyrinthe.*)

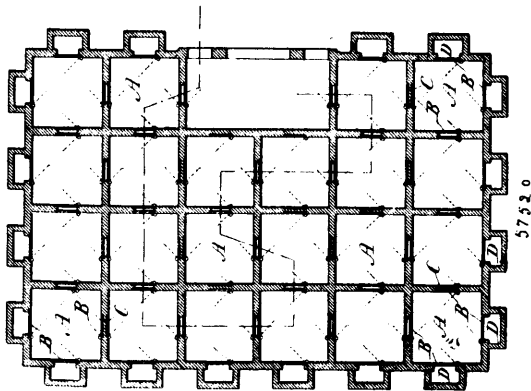

Percy G. Williams, Brooklyn, New York, U.S.A., 21st September, 1897; 6 years. (Filed 24th August, 1897.)

*Claim.*—1st. A maze or labyrinth, consisting of chambers or enclosures, each chamber or enclosure being provided with a plurality of doors, some of which open on blank walls, and others communicating with adjacent chambers, substantially as specified. 2nd. A maze or labyrinth, consisting of a series of chambers or enclosures, cupboards communicating with the chambers, a plurality of doors

in each chamber, or enclosure, some of which open on blank walls, some on cupboards, and others into adjacent chambers, and communicating openings between said chambers, or enclosures, provided with double doors, substantially as specified.

**No. 57,521. Envelope Fastener.** (*Attache d'enveloppe.*)

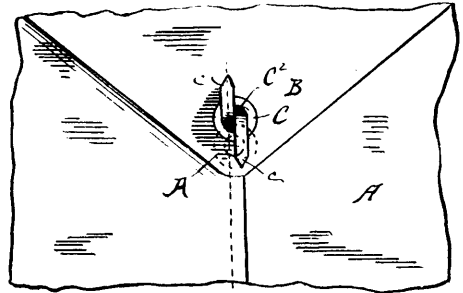

Edward A. Day, Worcester, Massachusetts, U.S.A., 21st September, 1897; 6 years. (Filed 16th August, 1897.)

*Claim.*—1st. An improved envelope fastener consisting of a piece of sheet metal cut and compressed into the form of a central eyelet or ferrule, having the integral prongs projecting together at right angles from one side of its head, upon the same plane as the face of said head, and adapted to be secured in an opening in the body of the envelope under its loose flap, with the two prongs lying flat against the outer face of said envelope, substantially as and for the purpose set forth. 2nd. An improved envelope fastener consisting of a piece of sheet metal cut and compressed into the form of a central eyelet or ferrule, having two integral prongs projecting together at right angles from one side of its head, upon the same plane as the face of said head, in combination with an envelope whose loose flap is provided with an eyeleted opening, and its body with a plain opening under where said eyeleted opening comes when the flap is folded against the body in closing the envelope, the aforesaid sheet metal fastener permanently secured in said plain opening of the envelope body by means of the central eyelet or ferrule, with the laterally projecting prongs lying flat against the outer face of said envelope body, and the loose flap being fastened to close the envelope by first bending the prongs together, substantially at right angles to the face of the central eyelet or ferrule, then inserting them through the eyelet opening in the flap and a sample of goods if the latter is placed thereon, and finally bending said prongs in opposite directions against the outer face of said flap or sample of goods, substantially as set forth.

**No. 57,522. Keyhole Guard.** (*Garde de serrure.*)

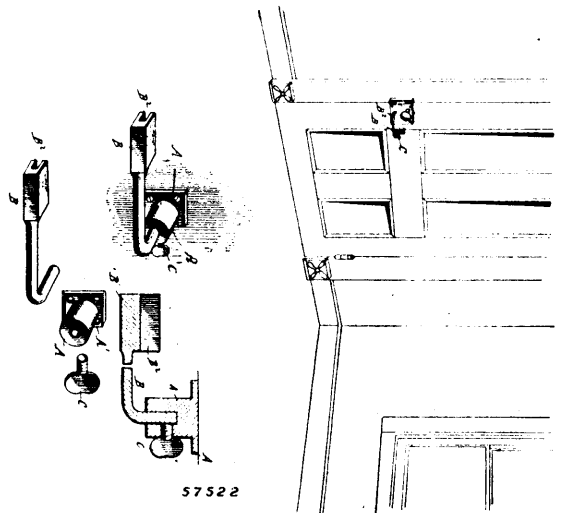

Ambrose J. Welker, Hellertown, Pennsylvania, U.S.A., 22nd September, 1897; 6 years. (Filed 4th August, 1897.)

*Claim.*—1st. In a keyhole guard or key fastener, the fastening rod having a recessed or slotted end adapted to receive the head of the key, and means for securing the opposite end of said rod to the door, substantially as shown and described. 2nd. In a keyhole guard or key fastener, a fastening rod having a recessed or slotted end, and a binding screw attached to the door and in which the opposite end of the rod is secured, substantially as shown and described. 3rd. The combination with the fastening rod having the recessed or slotted

end, of the binding post, tubular in form, the fastening rod being right angular in shape, one end thereof being fitted into the tubular post, and the set screw for securing the said rod in the post, substantially as shown and described. 4th. The combination with the fastening rod, right angular in shape, having one end thereof recessed or slotted, the tubular binding post having a base flange, and the set screw for securing the rod in the post, substantially as shown and described.

**No. 57,523. Saw-Mill Set-Work.**

(*Declie de chariot de scierie.*)

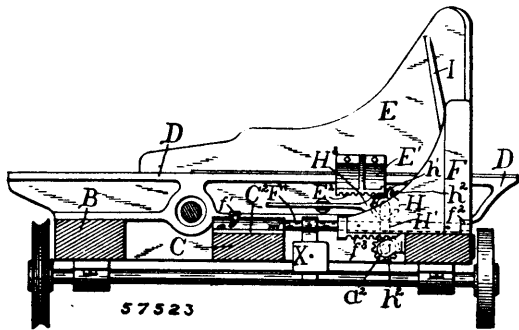

Richard Francis Downey and Mathew Alexander Burns, both of Menominee, Michigan, U.S.A., 22nd September, 1897; 6 years. (Filed 5th August, 1897.)

*Claim.*—1st. In saw-mill set-works, the combination with the head-blocks and the main knees, and means for advancing and retiring the said knees, of a supplemental knee pivotally mounted upon the carriage, and means operated by the set-works mechanism for operating said supplemental knee, substantially as described. 2nd. In saw-mill set-works, the combination with the head-blocks and the main knees, and means for advancing and retiring the said knees, of a supplemental knee pivotally mounted upon the carriage, and means operated by one of the main knees for operating said supplemental knee, substantially as described. 3rd. In saw-mill set-works, the combination with the head-blocks and the main knees, and means for advancing and retiring the said knees, of a supplemental knee pivotally mounted upon the carriage, and means operated by the forward movement of the carriage for raising said supplemental knee to a vertical position and advancing the same, substantially as described. 4th. In saw-mill set-works, the combination with the head-blocks and the main knees, and means for advancing and retiring the said knees, of a supplemental knee pivotally mounted upon the front part of the carriage, and adapted, when not in operation, to be folded in a horizontal position upon said carriage, and means operated by the forward movement of the main knees, for raising said supplemental knee to a vertical position and advancing the same in line with said main knees, substantially as and for the purposes described. 5th. In saw-mill set-works, the combination with the head-blocks and the main knees, and means for advancing and retiring the said knees, of a supplemental knee pivotally mounted upon the carriage, devices carried by said supplemental knee for gripping the cant, and devices operated by the mechanism of the set-works for operating said supplemental knee, substantially as described. 6th. In saw-mill set-works, the combination with the head-blocks and the main knees, and means for advancing and retiring the said knees, of a supplemental knee pivotally mounted upon the forward part of said carriage, and adapted, when not in operation, to be folded in a horizontal position upon said carriage, devices carried by said supplemental knee for gripping the cant, and devices operated by the mechanism of the set-works during the forward movement of the main knees, for raising said supplemental knee to a vertical position and for advancing the same in line with said main knees, substantially as and for the purposes described. 7th. In saw-mill set-works, the combination with the head-blocks and the main knees, and means for advancing and retiring the said knees, of a slideway mounted transversely upon the carriage, a slide mounted in said slideway, a supplemental knee pivotally mounted upon said slide, and devices operated by the set-works mechanism for advancing and retiring said slide, and devices for imparting to said supplemental knee a motion about its pivotal point, substantially as described. 8th. In saw-mill set-works, the combination with the head-blocks and the main knees, and means for advancing and retiring the said knees, of a slideway mounted upon the forward part of the carriage transversely of said carriage, a slide mounted in said slideway, a supplemental knee pivoted upon said slide, and devices operated by the set-works during the forward movement of the main knees, for turning said supplemental knee in said slide, and for advancing said slide, substantially as and for the purposes described. 9th. In saw-mill set-works, the combination with the head-blocks and the main knees, and means for advancing and retiring the said knees, of a slideway mounted transversely upon the carriage, a slide mounted in said slideway, a supplemental knee pivoted upon said slide, a rack on said slide, a shaft journaled

in said carriage, a pinion on said shaft gearing with said rack, means operated by the set-works mechanism for rotating said shaft, and means for imparting to the said supplemental knee a motion about its pivotal point, substantially as described. 10th. In saw-mill set-works, the combination with the head-blocks and the main knees, and means for advancing and retiring the said knees, of a slideway mounted upon the forward part of the carriage transversely thereof, a slide mounted in said slideway, a supplemental knee pivoted upon said slide, a rack on said slide, a shaft journaled in said carriage, a pinion on said shaft gearing with said rack, a second pinion on said shaft, and a rack mounted upon one of the main knees and adapted to engage said second pinion, and means for imparting to the said supplemental knee a motion about its pivotal point, substantially as described. 11th. In saw-mill set-works, the combination with the head-blocks and the main knees, and means for advancing and retiring the said knees, of a slideway mounted upon the forward part of the carriage transversely thereof, a slide mounted in said slideway, a shaft journaled in said slide and extending rearwardly therefrom, a supplemental knee fixed upon said shaft in said slide, a guide box inclosing the rear end of said shaft, and provided with a longitudinal slot therein having a curved rear portion, a guide-bolt on said shaft working in said slot, and means operated by the set-works mechanism for causing said slide to advance and retire, substantially as described. 12th. In saw-mill set-works, the combination with the head-blocks and the main knees, and means for advancing and retiring the said knees, of a slideway mounted upon the forward part of the carriage transversely thereof, a slide mounted in said slideway, a shaft journaled in said slide and extending rearwardly therefrom, a supplemental knee fixed upon said shaft in said slide, a rack on said slide, a guide-box having a longitudinal slot therein with a curved rear end, inclosing the rear end of said shaft, a guide-bolt on said shaft working in said slot, a second shaft journaled longitudinally of the said carriage, a pinion on said shaft gearing with said rack, a second pinion on said shaft, and a rack carried by one of the main knees adapted to engage said second pinion and rotate said longitudinal shaft, substantially as described. 13th. In a saw-mill set-works organization, the combination with the head-blocks and the main knees, and means for advancing and retiring the said knees, of a supplemental knee pivotally mounted in a slideway upon the forward part of the carriage, a shaft rigidly connected to said pivoted knee, a guide box inclosing the rear end of said shaft and allowing of a partial rotary motion, and longitudinal motion thereof, a rack connected to said supplemental knee, a second shaft journaled longitudinally of said carriage, and means for rotating said longitudinal shaft, and a pinion fixed on said shaft and gearing with said rack, for operating said supplemental knee, substantially as described. 14th. In a saw-mill set-works organization, the combination with the head-blocks and the main knees, and means for advancing and retiring the said knees, of a supplemental knee pivotally mounted in a slideway transversely upon the carriage, a shaft rigidly connected to said pivoted knee, a guide box inclosing the rear end of said shaft and allowing a longitudinal motion and a partial rotary motion thereof, a rack connected to said shaft, a second shaft journaled longitudinally in said carriage, a pinion on said longitudinal shaft, means for rotating said pinion, means for throwing said pinion into and out of gear, a second pinion on said horizontal shaft gearing with said rack, substantially as described. 15th. In a saw-mill set-works, the combination with the head-blocks and main knees, and means for advancing and retiring the said knees, of a supplemental knee pivotally mounted upon the carriage, a horizontally movable plate mounted upon the said supplemental knee, means carried by said knee for projecting said plate edgewise beyond the face of said knee and withdrawing the same, and means operated by the set-works mechanism for operating said supplemental knee, substantially as described. 16th. In a saw-mill set-works, the combination with a pivoted central knee, of cant gripping devices carried by said knee, a horizontally movable plate mounted upon said knee, means for operating said cant gripping devices and said movable plate simultaneously, and means for operating said central knee from the set-works mechanism, substantially as described. 17th. In saw-mill set-works, the combination with a pivoted central knee, of a horizontally movable plate mounted upon said knee, means for operating said plate, and means for operating said central knee from the set-works mechanism, substantially as described.

**No. 57,524. Gate. (Barrière.)**

David F. Baker, Vernonia, Oregon, U.S.A., 22nd September, 1897; 6 years. (Filed 4th September, 1897.)

*Claim.*—1st. The combination of sliding gate sections, transverse rack-bars connected with the sliding gate sections, longitudinally disposed rack bars extending from opposite sides of the gate sections, a pair of pinions meshing with the rack-bars and means for operating the longitudinally disposed rack-bars, substantially as and for the purpose described. 2nd. The combination of sliding gate sections, slides disposed at opposite sides of the gate sections, the longitudinal and transverse rack-bars geared together and connected, respectively to the slides and to the gate sections, pivoted bars mounted on the slides, extending upward therefrom and adapted to be engaged by an axle of a vehicle, whereby the slides are moved inward and outward, and means for tripping the pivoted bars at the ends of the movement of the slides to cause the said bars to swing

downward to permit an axle to pass over them, substantially as described. 3rd. In an automatic gate, the combination of a slide, a

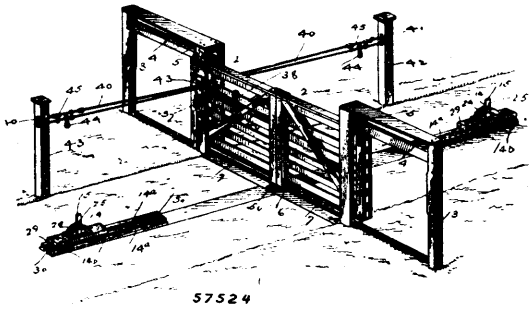

sliding gate section, gearing connecting the slide with the gate section, a pivoted arm mounted on the slide, extending upward therefrom and adapted to be engaged by a vehicle, trip levers fulcrumed between their ends at the bottom of the bottom of the slide, extending in opposite directions from the lower end of the pivoted bar and provided at their inner ends with shoulders to be engaged by the same, whereby the pivoted bar is locked in an upright position, and projections arranged to engage the trip levers to throw the same out of engagement with the pivoted bar, substantially as shown and described. 4th. The combination of a slide, a gate section, gearing for connecting the slide with the gate section, a pivoted bar mounted on the slide, a spring connected with the bar and adapted to return the same to a perpendicular position, longitudinally disposed trip levers fulcrumed on the slide, arranged to engage the pivoted bar, and provided at their outer ends with inclined edges, and projections arranged to be engaged by the inclined edges of the trip levers, substantially as described. 5th. The combination of the sliding gate sections, slides located at opposite sides of the same, gearing connecting the gate sections with the slides, a catch mounted on one of the gate sections, and engaging the said gearing, and operating ropes or cables extending from opposite sides of the gate sections, and connected with the said catch and the gate section upon which the said catch is mounted, whereby such gate section is operated independently of the slides and the said gearing, substantially as described. 6th. The combination of the sliding gate sections 1 and 2, transverse rack-bars 8 and 9, longitudinally disposed rack-bars, gearing connecting the rack-bars, an arm extending from the rack-bar 8, a catch mounted on gate section 1 and engaging the said arm, a catch lever fulcrumed on the gate section 1 and connected with the catch, an operating lever mounted on the gate and adapted to engage the catch lever, and operating ropes or cables connecting with the operating lever, substantially as described. 7th. The combination of the sliding gate section 1, and rack-bar 8, provided with horizontal and vertical arms, a loop depending from the gate section 1, and receiving the horizontal arm of the rack-bar, a catch mounted on the bottom of the gate and engaging the vertical arm of the rack-bar, gearing for operating the rack-bar, a lever 37, fulcrumed on the gate, and connected with the catch, an operating lever mounted on the gate and arranged to engage the lever 37, and operating ropes or cables connected with the operating lever, substantially as described. 8th. The combination of the sliding gate section, operating ropes or cables extending from opposite sides of the gate section and connected with the same, sliding frames mounted on the operating ropes and each provided with a longitudinal rod provided with a central eye, transverse links provided with eyes receiving the rods and the opposite portion of the adjacent rope or cable, and handles having eyes linked into the central eyes of the rods, substantially as described. 6th. The combination of the transverse and longitudinal rack-bars, gearing connecting the rack-bars, adjustable plates arranged adjacent to the rack-bars and provided with rollers engaging the same, and adjustable braces connecting with the adjustable plates, substantially as described. 10th. The combination with the sliding gate sections, longitudinal track-bars provided with horizontal flanges, a slide arranged on the track-bars and provided with depending flanges interlocked with the same, gearing connecting the slide with the gate sections, and a bar mounted on the slide and adapted to be engaged by a vehicle, substantially as described. 11th. The combination with a gate section and a rack-bar, of a locking device connecting the same composed of an upper section having an open eye or hook, a lower section engaging the open eye or hook and provided at one side with a stop, and a pivoted arm mounted on the other side of the lower section, substantially as described.

#### No. 57,525. Car Coupler. (Attelage de chars.)

Thomas Galligan and John Porter, both of Bradford, Ohio, U.S.A., 22nd September, 1897; 6 years. (Filed 4th September, 1897.)

*Claim.*—1st. The combination with a chambered draw-head and a pivoted knuckle having a hook-like latching jaw and a lateral projection opposite said jaw, of a rod pivoted to said draw-head and supporting a spring adapted to hold said jaw in coupled engagement, the free end of said rod passing through said projection, a lever ful-

crumed on the car frame, and a link pivoted to said projection and to said lever, as specified. 2nd. In a side latching car coupling, the

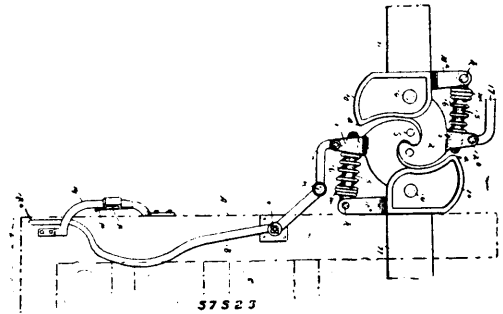

combination with the chambered draw-head having an arm extending therefrom and a knuckle having a hook-like latching jaw pivoted in said draw-head, of a rod pivoted to said arm, and carrying a spring adapted to normally hold said knuckle in closed adjustment, and means for opening said jaw against the action of said spring, as specified. 3rd. In a side latching car coupling, the combination with a chambered draw-head having an opening therein at the front and near one side of the chamber, of a knuckle having a hook-like latching jaw, a tailpiece integral with said knuckle concentrically pivoted in said opening, said tailpiece being provided with a toe adapted to limit the closure of said latching jaw, and a rod pivoted to an arm projecting from said draw-head and supporting a spring adapted to keep said toe normally in contact with the rear wall of the draw-head chamber, as specified. 4th. In a side latching car coupling, the combination with the draw-head having an arm extending therefrom, of a knuckle pivoted in said head provided with an integral hook-like latching jaw and tailpiece, a limb extending laterally from the rear side of said knuckle having an orifice therein, and a spring encircled rod pivoted at one end on said arm, its other end passing through said orifice, the tension of the spring normally pressing said arm and limb apart, as and for the purpose specified. 5th. In a side latching car coupling, the combination with a draw-bar, a draw-head thereon having a chamber open partly at the front, and an arm laterally projected therefrom near the draw-bar, of a knuckle block having a hook-like latching jaw, and provided with a lateral limb which is transversely perforated, a carrier rod pivoted on the end of the arm engaging the perforation of said limb, a spring on said carrier rod adapted to press the latching jaw partly across the median line of draft force applied to the coupling, a link pivoted to a limb and also to the end of a bent lever that is fulcrumed on the car frame, and a bracket plate on said frame adapted to retain the lever when the latter is rocked, to hold the knuckle open, as specified. 6th. In a side latching car coupling, the combination with a chambered draw-head and a knuckle pivoted therein having a hook-like latching jaw and an integral tailpiece, said tailpiece being provided with a toe adapted to limit the closure of said latching jaw, of a laterally extending arm formed on said draw-head at its rear, a laterally extending limb formed on said knuckle having an oblong orifice therein, a rod pivoted on one end of said arm, its other end passing loosely through said orifice, a spring encircling said rod arranged to normally force said rod out of said orifice, and keep said toe in contact with the rear wall of said draw-head chamber, and means for counteracting the action of said spring, as specified.

#### No. 57,526. Hot Water Heating System.

(Appareil de chauffage à l'eau chaude.)

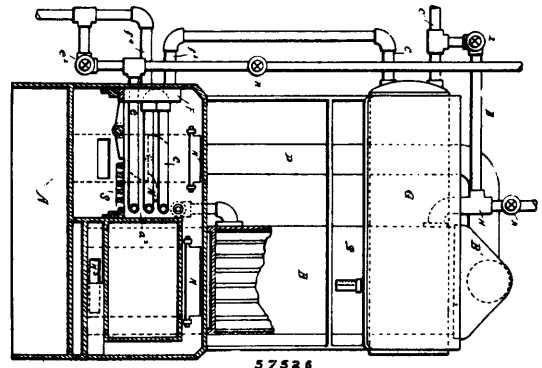

William H. Hallowell, Morristown, Edward C. Batchelor and William Batchelor, both of Philadelphia, all in Pennsylvania, U.S.A., 22nd September, 1897; 6 years. (Filed 4th September, 1897.)

*Claim.*—1st. In combination with a range having a smoke outlet formed in its top, a boiler connecting with the water-back of the range, of flues arranged in the cylinder, adapted to conduct there-through the products of combustion from the range, substantially as set forth. 2nd. In combination with a range having a smoke outlet in its top, a hot water boiler connected with the water-back of the range, of a removable cylinder or drum adapted to fit snugly at its lower end in the smoke outlet, an inlet pipe connecting at one end with the interior of said cylinder, and provided at its other end with a detachable coupling by which it can be connected with a supply pipe leading from the boiler, an outlet pipe communicating with said cylinder near its upper end, and adapted to be detachably connected with the system of distributing pipes, and a series of flues arranged in said cylinder to conduct the products of combustion of the range through the chimney, substantially as set forth. 3rd. In a hot water heating system, the combination with a range, a hot water heating device located therein, a boiler connected at its bottom to the water heating device, and a radiator supply pipe connected to the top of said boiler, of a hot water tank, a radiator return pipe connected to the bottom of said water heating device, a pipe connecting said boiler and hot water tank, and means of controlling the flow of water therein from said boiler, and a cold water supply pipe connected to the bottom of the water heating device in the range, substantially as described. 4th. In a heating system, the combination with a fire-pot formed of a coil of pipe, in the shape of a rectangle having one open side, of a water-back filling the said open side a summer fire-pot insertable within the coil fire-pot, substantially as described. 5th. In a heating system, the combination with a fire-pot formed of coil pipe in the shape of rectangle having one open side, of a water-back filling said open side and provided with a forwardly projecting flange at its upper end and a summer fire-pot insertable within the coil fire-pot, and having a perforated ledge resting upon the inner wall of the stove, substantially as described. 6th. In a heating system, the combination with a fire-pot formed of a coil, a water-back adjacent to the coil, of a removable fire summer fire-pot insertable within the coil, means for supporting said fire-pot upon the inner walls of the stove, and means for admitting air between said coils and summer fire pot, substantially as described. 7th. In a heating system, the combination with a coil fire-pot and a summer fire-pot arranged to fit within said coil fire-pot, and having a perforated rim, of a damper arranged to close the perforations in the rim, substantially as described. 8th. In a heating system, the combination with a range of a coil fire-pot, a tubular boiler connecting with the smoke outlet of said range, flues and dampers leading from said coil fire-pot to said boiler, a water-back adjacent to said coil, a hot water tank connected with said water-back and boiler, and means for conducting the hot water generated in said water-back and boiler, throughout the various parts of a building, substantially as described. 9th. In a heating system, the combination with a range of a coil fire-pot having a grate adapted to form the bottom thereof, a water-back adjacent to said coil, a tubular boiler connecting with said smoke outlet in said range, a cold water inlet to said water-back, a hot water tank, means for conducting the water from said water-back to said tank, means whereby the water may be withdrawn from said hot water tank, said coil fire-pot being connected with a cold water inlet, and an outlet leading to the lower end of said boiler, a dust flue communicating between the smoke flue and ash-pit, means for controlling the draught therethrough, means for controlling the heat from fire-pot whereby it may be directed either over the oven or out through the flues of the boiler, around the oven, and thence out through the oven flues to the boiler, or directly out through the dust flue, and means for connecting said boiler and coil fire-pot with the radiators distributed throughout the building, substantially as described.

**No. 57,527. Window. (Fenêtre.)**

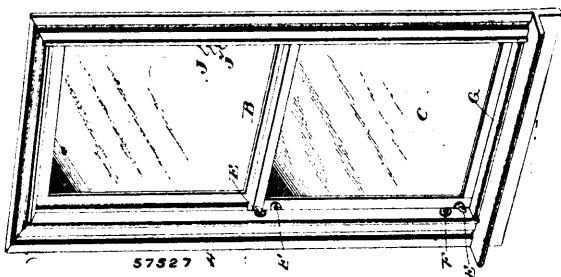

Lewis Seeley Bradshaw and Samuel J. Fell, both of Buffalo, New York, U.S.A., 22nd September, 1897; 6 years. (Filed 27th August, 1897.)

*Claim.*—1st. In a window, the combination with the frame, having the socket plate and hook secured thereto, of the sliding sash also having a hook and socket plate secured thereto, co-operating respectively with the hook and socket plate on the frame to form a hinge joint, substantially as and for the purpose set forth. 2nd. In a window, the combination with the frame and sash, of the hooks secured thereto having the curved portion bent out of the plane of the body

or shank, and the co-operating socket plates secured to the frame and sash, substantially as and for the purpose set forth. 3rd. In a window, the combination with the frame and sash, of the hooks and socket plates secured thereto, said socket plates having the lip, substantially as described.

**No. 57,528. Curry Comb. (Etrille.)**

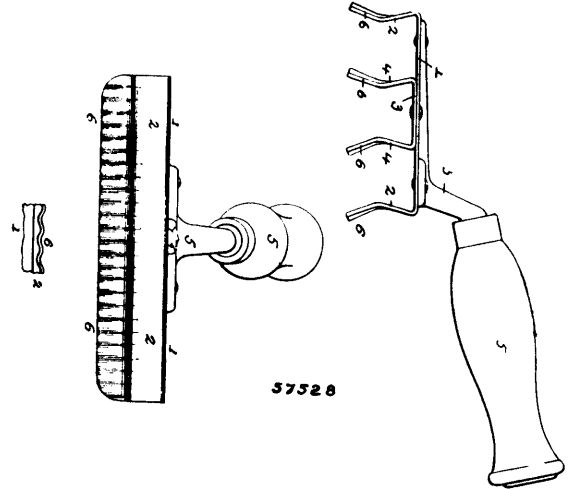

Lorenzo B. Baker, Racine, Wisconsin, assignee of William E. Phillips, Victor, Colorado, both in the U.S.A., 22nd September, 1897; 6 years. (Filed 6th September, 1897.)

*Claim.*—1st. A curry comb, comprising a back or base portion, and blades 2 and 4, that are fluted from their free ends inwardly towards the base, with their outer narrow surfaces of a plane or flat nature to admit of sharpening, such blades being set obliquely so as to impart a wavy nature to the scruffing or currying edges of the blades, substantially as set forth. 2nd. A curry comb, comprising a back or base portion, and blades 2 and 4, that are fluted from their free ends inwardly toward the base, with their outer narrow surfaces of a plane or flat nature to admit of sharpening, such blades being set obliquely and in opposite and outward directions, so as to impart a wavy nature to the scruffing or currying edges of the blades, substantially as set forth.

**No. 57,529. Metal Egg Case. (Boite à œufs.)**

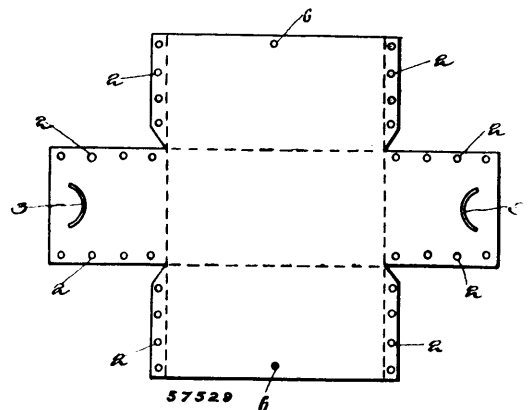

Henry Harvey Knight and Minter Earle Jackson, both of Janelewe West Virginia, U.S.A., 22nd September, 1897; 6 years (Filed 6th September, 1897.)

*Claim.*—1st. An improved metal case or crate consisting of a body portion formed integrally from a sheet of metal with its edges riveted together, an overlapping top portion similarly constructed, and a transverse rod adapted to pass through registering apertures in the top and body portions, and means for securing said rod after being so placed. 2nd. In a metal case or crate, the combination with the body portion formed from a single metal sheet, of an overlapping top portion similarly formed, a transverse rod adapted to be passed through registering apertures in the top and body portions of the case, a head formed upon one end of said rod and an aperture in the opposite end, and a snap-ring adapted to be secured within said aperture. 3rd. An improved metal casing or crate for eggs or other articles consisting of a body portion integrally formed from a single sheet, a transverse partition centrally dividing the interior of said body portion, an overlapping top portion formed similarly to

the body portion, a rod adapted to be passed transversely through registering apertures in the top and body portions, and means for securing said rod in said position, the whole construction arranged and adapted for operation, substantially as herein set forth.

**No. 57,530. Car Roof. (Toiture de chars.)**

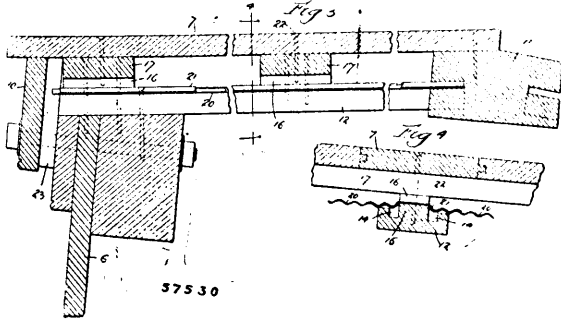

The Chicago and Cleveland Car Roofing Co., Chicago, assignee of James John McCarthy, Austin, both in Illinois, U.S.A., 22nd September, 1897; 6 years. (Filed 6th September, 1897.)

*Claim.*—1st. In a roof, the combination with supporting devices, and roofing plates at each side thereof, of intermediate plates connected to said supporting devices and projecting at each side thereof, and extending parallel with and fitting closely upon the roofing plates, forming practically a continuation of the roofing plates, substantially as described. 2nd. In a roof, the combination with rafters, and corrugated roofing plates at each side thereof, of intermediate corrugated plates connected to the rafters and projecting at each side thereof, and extending parallel with and fitting closely upon the roofing plates, forming practically a continuation of the roofing plates, substantially as described. 3rd. In a roof, the combination with rafters and roofing plates at each side thereof, of intermediate plates projecting at each side of the rafters and extending substantially parallel with and fitting closely upon the roofing plates, forming practically a continuation of the roofing plates, substantially as described. 4th. In a car roof, the combination with rafters having gutters at each side, and roofing plates at each side of said rafters, of intermediate plates projecting over said gutters and engaging the roofing plates, substantially as described.

**No. 57,531. Bed Slat Support and Bracket. (Support de planches de couchettes et console.)**

(Support de planches de couchettes et console.)

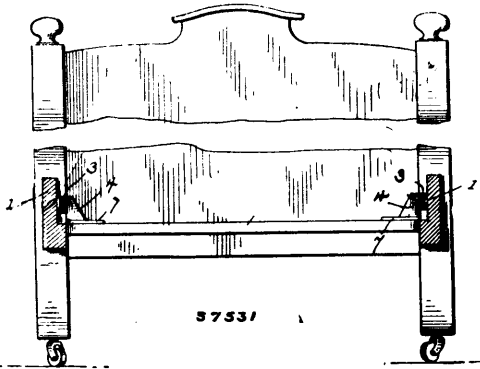

Daniel Gaunt Corbin, Lovettsville, Virginia, U.S.A., 22nd September, 1897; 6 years. (Filed 7th August, 1897.)

*Claim.*—The combination with a bracket adapted to be secured to the side rail of a bed, and formed with a square recess on its outer side, and with a narrow vertical slot communicating with said recess, of a support adapted to be secured to the end of a slat, and provided with a standard having a narrow neck and a rectangular head, said neck adapted to the vertical slot of the bracket, and said head to the rectangular recess of the bracket, substantially as set forth.

**No. 57,532. Plough. (Charrue.)**

Cullin William Reed, Oakley, Michigan, U.S.A., 22nd September, 1897; 6 years. (Filed 17th September, 1897.)

*Claim.*—1st. A double ended plough, having right and left mould-boards rigidly connected to each other and provided with a reversible beam so constructed as to operate both ends of the plough, substantially as set forth. 2nd. A double ended plough having a double mould-board, plough-shares, coulter and a single continuous landside all rigidly connected, and a plough-beam pivotally secured thereto substantially as set forth. 3rd. A reversible plough having a single con-

tinuous landside, a double mould-board, and plough-shares the cutting edges of which said plough-shares are scalloped out substantially as

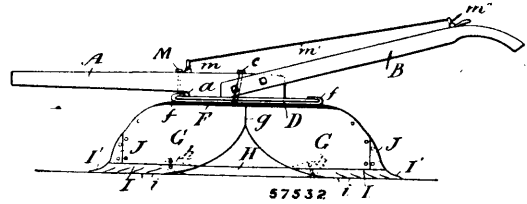

set forth. 4th. A reversible plough the combination with the beam A and plate D, of the plate F, bar E carrying the mould-boards, plough-shares, landsides and coulters of a double ended plough, a bolt C pivoting the said beam to the bar E, jaws ff formed on the ends of the said plate F, a sliding bolt M passing through the said beam and engaging a perforation in the said jaws, substantially as set forth. 5th. A mould-board for a plough in the form of a portion of a right cylinder, substantially as set forth. 6th. A plough-share having its cutting edge scalloped out, substantially as set forth.

**No. 57,533. Meter. (Mètre.)**

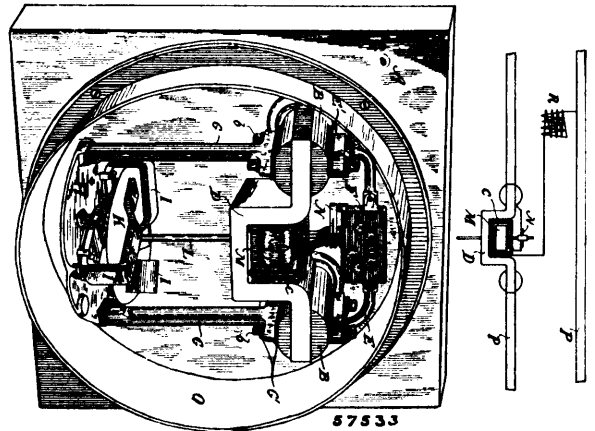

The Canadian General Electric Company, Toronto, Ontario, Canada, assignee of Walter C. Fish, Lynn, Massachusetts, U.S.A., 22nd September, 1897; 6 years. (Filed 24th February, 1896.)

*Claim.*—1st. In a motor meter, as herein set forth, the combination with an armature, of a U-shaped conductor forming the field winding, said armature being located within the bend of the U-shaped magnet, and connected in shunt across the circuit mains. 2nd. In an electric meter, as herein described, the combination with an armature connected to a registering mechanism, of a U-shaped conductor having a conductivity sufficient to convey the maximum current which will at any time flow through the main in which it is connected, the armature being located within the bend of the U-shaped conductor. 3rd. In an electric meter, as herein described, the combination with an armature and a heavy U-shaped conductor, as herein described, of heavy binding posts to which the conductor is connected, an arch mounted on the binding posts and insulated therefrom and carrying the registering mechanism, and a retarding device. 4th. In an electric meter, as herein set forth, an armature and registering mechanism, and retarder connected with the ends of the armature shaft, in combination with a U-shaped conductor, as herein described, having binding posts by which the U-shaped conductor is supported, and a metallic arch carrying the registering mechanism and mounted on the binding posts and insulated therefrom. 5th. The combination with the recording mechanism of an electric meter, of an armature connected in shunt across the circuit mains, and a conductor comprising less than a complete turn in series with one of the circuit mains and in inductive relation to said armature. 6th. The combination in an electric meter, of a set of binding posts adapted to be connected to the terminals of one of the omnibus bars from a current generating source, a main field conductor connected between and supported by said binding posts supports also carried by said binding posts and serving to sustain the regulating and registering mechanisms, respectively, and an armature carried upon a shaft having bearings in said supports. 7th. The combination in an electric meter, of a set of binding posts adapted to be connected to one of the omnibus bars from a current generating source, a main field conductor between and supported by said binding posts, and supports for the movable element of the meter also carried by said binding posts.

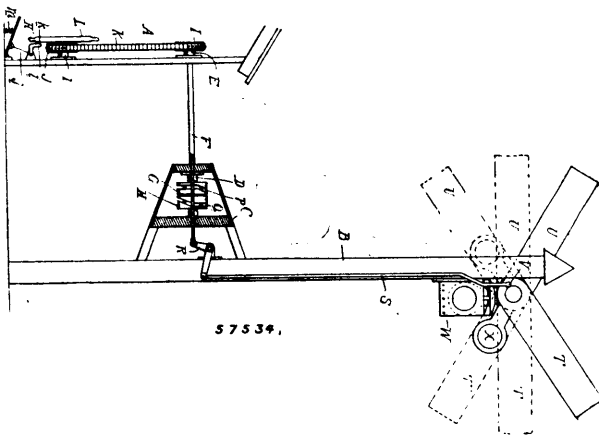

**No. 57,534. Signal Operating Mechanism.***(Signal actionné par un mécanisme.)*

Stephen R. Payne, Frank H. Payne and Henry J. Bailey, all of Ashtabula, Ohio, U.S.A., 22nd September, 1897; 6 years. (Filed 10th August, 1897.)

*Claim.*—1st. In a signal operating mechanism, the combination with a plurality of signals, and an actuating device therefor capable of a progressively forward movement whereby said signals are set to different combinations, and by such continuous forward movement said signals will be re-set to their initial position, as described and shown. 2nd. In a signal operating mechanism, the combination with a revoluble drum provided with a plurality of continuous and independent grooves, mechanism for revolving said drum, a plurality of signals, and intermediate connections between the grooved drum and each of said signals, substantially as described and shown. 3rd. In a signal operating mechanism, the combination with a revoluble shaft and a device for actuating the same, a cam mechanism operated by the shaft comprising a drum provided with two or more continuous and independent grooves, a plurality of signals, and intermediate connections between the grooved drum and each of said signals, whereby, upon partial rotation of said drum, various position combinations of the signals are obtained, and upon the complete rotation of the drum the signals will be returned from their positions assumed in their various combinations, to their initial positions, substantially as described and shown. 4th. In a two-way train order and block signal operating mechanism, the combination with a revoluble shaft, of a hand-wheel connected to and adapted to operate the same, indicators showing the various combinations of the signals arranged upon the wheel, a cam mechanism operated by the shaft, and intermediate connections between the cam mechanism and each of said signals, substantially as described and shown. 5th. In a switch or signal operating mechanism, the combination with a revoluble shaft, of a hand-wheel connected to and adapted to rotate the same, indicators showing the various combinations of the switches or signals arranged upon the wheel, a cam mechanism fixedly secured upon the shaft, and intermediate connections between the cam mechanism and each of a plurality of signals, substantially as described and shown. 6th. In a signal operating mechanism, the combination with a plurality of signals, an actuating device therefore, capable of a progressively forward movement whereby the signals are set to different combinations, and by such continuous forward movement will be re-set to their initial position, and means for locking the signals after the required combinations have been formed, substantially as described and shown. 7th. In a signal operating mechanism, the combination with a revoluble shaft, of a hand-wheel connected to and adapted to operate the same, indicators arranged upon the wheel, a plurality of signals, a cam mechanism operated by the shaft, intermediate connections between the cam mechanism and each of said signals, and means for locking the wheel, substantially as described and shown. 8th. In a signal operating mechanism, the combination with a plurality of signals, an actuating device therefore capable of a progressively forward movement whereby said signals are set to different combinations, and by such continuous forward movement will be re-set to their initial position, and means for indicating the various combinations assumed by the signals during the progressively forward movement of the signal actuating device, substantially as described and shown.

**No. 57,535. Jack Strap. (Suspensoir.)**

George A. Mattern, San Francisco, California, U.S.A., 22nd September, 1897; 6 years. (Filed 23rd August, 1897.)

*Claim.*—The combination of the front and back pieces having straight and curved edges, the integral piece connecting the same,

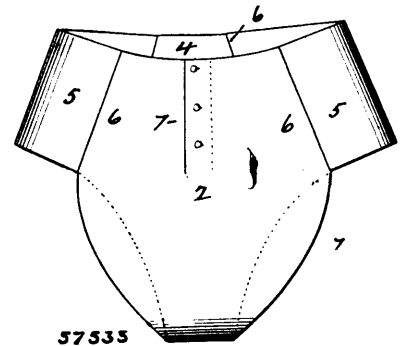

and the elastic belt pieces secured to the said straight edges of the front and back as set forth.

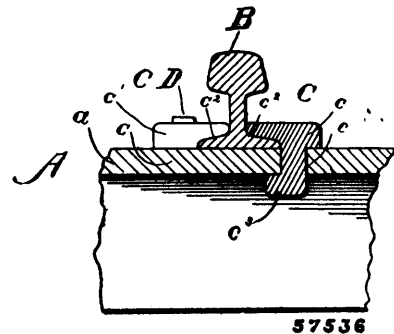
**No. 57,536. Railway Tie and Fastening Device.***(Traverse de chemin de fer et appareil à assujettir.)*

Elijah B. Gilpin, Davis, West Virginia, U.S.A., 22nd September, 1897; 6 years. (Filed 20th August, 1897.)

*Claim.*—1st. In a railway tie, the combination with said tie of a rail and a clamping block adapted to engage the tie whereby said rail is firmly clamped thereto, substantially as described. 2nd. A railway tie having strengthening ribs and flanges adapted to anchor said tie and retain the ballast in position beneath said tie, substantially as described. 3rd. The combination with a railway tie having strengthening ribs and flanges adapted to act as anchors and ballast supports and provided with holes in the top plate thereof, of means for engaging said holes whereby the rails are firmly clamped to said tie, substantially as described. 4th. The combination of a railway tie having strengthening ribs and flanges adapted to act as anchors and ballast supports, and provided with holes through the top plate thereof, and clamping blocks adapted to engage through said holes and firmly clamp the rail flanges and tie together, substantially as described. 5th. In a railway tie, the combination of a plate having ribs and flanges to act as anchors and retain the ballast, and oblong holes formed therein adjacent to the flanges of the rails, clamping blocks provided with heads thereon, one of which is arranged to engage through said openings with the under side of said plate, and the other of which is adapted to engage the lower flange of the rail and means for retaining said clamping block in its adjusted position. 6th. In a railway tie, the combination with said tie having bracing ribs and flanges adapted to anchor said tie, and oblong openings formed in said plate adjacent to the rails thereof, clamping blocks provided with heads and square shanks arranged to extend through said openings, and to turn therein, whereby said heads are made to clamp the plate and rail flange together, and springs adapted to be inserted in said openings whereby said clamping blocks are held from disadjustment, substantially as described.

**No. 57,537. Propelling Device for Ships.***(Appareil de propulsion pour vaisseaux)*

Frank Alexander Ludwig Grunow, Columbus H. Allen and Alphonso D. Riffel, all of New Orleans, Louisiana, U.S.A., 22nd September, 1897; 6 years. (Filed 25th August, 1897.)

*Claim.*—1st. In a propelling device for ships, the combination with the propelling shaft B, the plate D, through which the shaft passes, the hub C, having a convex flange, of the circular series of blades E secured at their rear ends to the said flange, their forward ends fastened to a ring G, substantially as described. 2nd. In a propelling device for ships, the combination with the propelling

shaft, of the plate D, having an annular shoulder portion *d*, of the hub C, mounted on the shaft, the convexed flange C', the outer

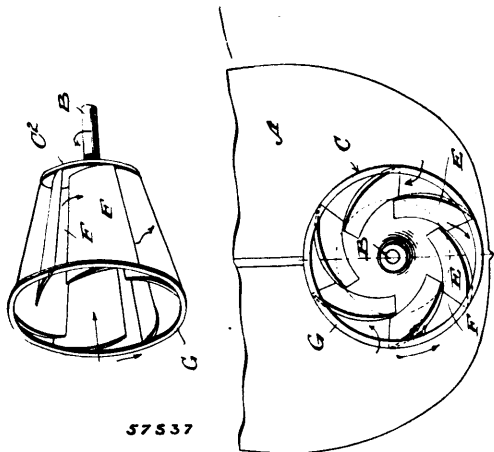

57537

circumference of the edge of which is designed to travel about the shoulder on the plate D, of the curved blades E, arranged substantially as shown and described.

**No. 57,538. Wagon Jack. (Chèvre de wagon.)**

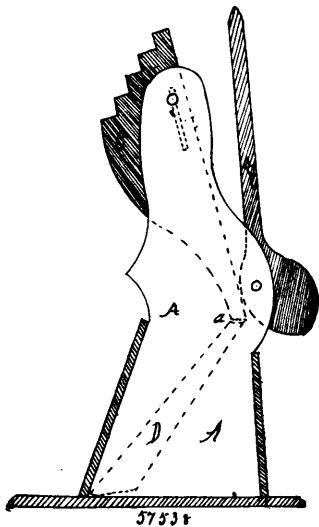

57538

Lucius Harvey Rand. Stanstead, Quebec, Canada, 22nd September, 1897; 6 years. (Filed 3rd September, 1897.)

*Claim.*—The combination of the upright pieces C and D, and a cam-lever B, substantially as and for the purpose hereinbefore set forth.

**No. 57,539. Clapboard Making Machine.**

(Machine à scier les planches à lambriser.)

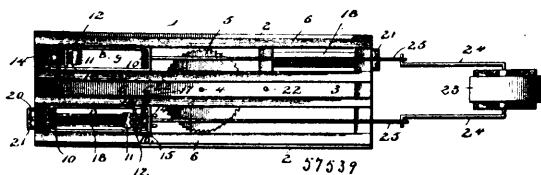

57539

Patrick Conway and Jeré Neterer, both of New Whatcom, Washington, U.S.A., 22nd September, 1897; 6 years. (Filed 3rd September, 1897.)

*Claim.*—1st. In a clapboard-sawing machine, a reciprocating bolt-carrier consisting of an open rectangular frame having inwardly-projecting teeth on one end of its walls, and a flange extending from side to side in advance of the other end wall and parallel therewith, a toothed dog arranged in front of the flange and having a stem projecting rearwardly through the flange and the end wall of the

carrier, a spring on the stem abutting against the end wall and tending normally to force the dog forward, an arm extending rearwardly from the dog through the flange and bent upwardly, a lever pivoted at one end to one side of the carrier and connected intermediate at its ends with the said arm, and a fixed stop on the machine-frame to engage the free end of the lever and cause it to retract the dog, substantially as described. 2nd. In a clapboard-sawing machine, a tilting table provided with central end journals one of which is supported in the end bar of the machine-frame and projects outwardly beyond it, and the other in a suitable bearing within the frame, a segmental rack 21 secured to the outer face of the said end bar concentric with the projecting journal, and a spring-arm connected to the projecting journal to rock the table and adapted to engage the teeth of the rack, to lock the table in its adjusted position, combined with a reciprocating bolt-carrier, and means to release the bolt from the carrier to permit it to drop onto the table, substantially as described.

**No. 57,540. Cigarette Packing Machine.**

(Machine à emballer les cigarettes.)

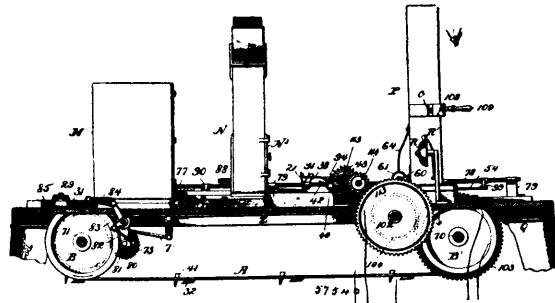

Charles Wallace Van Vleet, Rochester, and Asa Hurd, Yonkers, both in New York, U.S.A., 23rd September, 1897; 6 years. (Filed 20th August, 1897.)

*Claim.*—1st. The combination of the continuous belt A, the magazine M for box blanks having a slotted bottom and a slot for egress of a blank, the pusher 30 adapted to press against the end of a blank and to start the same through the slot in the direction of the movement of the belt and then to disengage from said blank, and a series of pickers 32 upon said belt moving through said slotted bottom and adapted to engage the edge of the started blank and to move the same with the belt, substantially as described. 2nd. The combination of the continuous belt A, means for moving boxes thereon, a magazine N for cigarettes having an orifice over the path of the belt and provided with vertical partitions 37 adapted to separate the cigarettes into vertical columns, the tray N<sup>2</sup> having downwardly-converging sides for delivering cigarettes to said magazine and between said partitions, the lever 89 and waved cam 88 for reciprocating the said tray transversely to distribute the cigarettes between said partitions, and means, as the plunger N<sup>1</sup>, for discharging cigarettes from said magazine to said boxes, substantially as described. 3rd. The combination, with a magazine for blanks having an orifice for the egress of a single blank, of a supporting plate 32 e, a picker 32 pivoted to said plate and having a forward edge 32 d adapted to engage a blank and a downwardly-projecting heel 32 b, a spring 33 tending to raise said edge, moving mechanism carrying said supporting-plate, and the guide 34 to depress said edge and compress said spring, substantially as described. 4th. In a packing-machine, the combination of the continuous belt A, the magazine N for a column of flat blanks, means, as pickers 32, for removing blanks therefrom one by one and for moving the blanks successively upon said belt, the magazine N for the filling material, and means for delivering successive charges of said material from said magazine to said blanks as they pass the same, as converging sides *u* in a channel in which said belt runs, for holding the sides of said blanks, a rod 78 reciprocating longitudinally of said machine, a plunger N<sup>1</sup> for discharging the charges of filling material from the magazine N to said blanks, connections between said rod and said plunger, devices for finishing the folding said blanks about the charge of material, and connections between said rod and said folding devices whereby the latter are operated, substantially as described. 5th. The combination of a magazine for blanks having a vertical slot 1 in a wall thereof, a blade 107 adapted to pass through said slot and to rest upon the mass of blanks, and a weighted yoke 108 embracing said magazine and attached to said blade, whereby the blade presses upon the blanks and is removable from said magazine, substantially as described. 6th. The combination of a magazine for blanks having a vertical slot 1 in the wall thereof, a blade 107 adapted to pass through said slot and rest upon the mass of blanks, a weighted yoke 108 embracing said magazine and attached to said blade and having a lug *o* thereon, a ball R, and a hammer-lever R<sup>2</sup>, in position to be operated by contact with said lug for striking said ball, substantially as described. 7th. In a machine for covering boxes, the combination of a cover-holder, a magazine P for covers adjacent to said holder and above the level thereof, means for discharging one cover

at a time from said magazine whereby the cover falls by gravity into the holder, and means, as a spring arm 64, for guiding the cover downward into the cover-holder, substantially as described. 8th. The combination, in a packing-machine, of a channel for filled boxes, a box-carrier A for moving a succession of boxes in said channel, a magazine P for box-covers above said channel and in line therewith, a cover-holder in line with said channel and adjacent to said magazine comprising a pair of opening jaws 55, 56, means for feeding one cover at a time between said jaws when open, and means for closing said jaws to hold said cover while the box is being inserted thereinto by said box-carrier, substantially as described. 9th. The combination, in a packing-machine, of a channel for filled boxes, a box carrier A for moving a succession of boxes in said channel, a magazine P for box-covers above said channel and in line therewith, a cover-holder in line with said channel and adjacent to said magazine comprising a pair of opening jaws 55, 56, means for feeding one cover at a time between said jaws when open, and means for closing said jaws by moving the same successively to hold said cover while the box is being inserted therein by said box-carrier, substantially as described. 10th. The combination, in a packing-machine, of a channel for filling boxes, a box-carrier A for moving a succession of boxes in said channel, a magazine P for box-covers above said channel and in line therewith, a cover-holder in line with said channel and adjacent to said magazine comprising a pair of opening jaws 55, 56, means for holding one edge of the cover up between the jaws, means for pressing the opposite edge of the cover downward between the jaws, and means for closing said jaws to open said cover and to hold the same while the box is being inserted thereinto by said box-carrier, whereby the jaws in closing press diagonally opposite edges of the cover to press the same into the rectangular form, substantially as described. 11th. The combination, in a packing-machine, of a channel for filled boxes, a box-carrier A for moving a succession of boxes in said channel, a magazine P for box-covers above said channel and in line therewith, a cover-holder in line with said channel and adjacent to said magazine comprising a pair of opening jaws 55, 56, means for holding one edge of the cover up within the jaws, means for pressing the opposite edge of the cover downward upon the jaws, and means for closing said jaws successively to hold said cover while the box is being inserted thereinto by said box-carrier, whereby the jaws in closing press diagonally opposite edges of the cover to press the same into rectangular form, substantially as described. 12th. The combination, in a packing-machine, of a channel for filled boxes, a bolt A running in said channel and provided with means for moving a succession of boxes thereon, a magazine P for box-covers above said channel and in line therewith, a cover-holder in line with said channel and adjacent to said magazine comprising a pair of opening jaws 55, 56, means for feeding one cover at a time from said magazine between said jaws when open, and means, as the cams 100, 101, acting upon said jaws to close the same while the box is being inserted thereinto by the movement of said belt and then to release the covered box, substantially as described. 13th. The combination, in a packing-machine, of a channel for filled boxes, a belt A running in said channel and provided with means for moving a succession of boxes thereon, a magazine P for box-covers above said channel and in line therewith, a cover-holder in line with said channel and adjacent to said magazine comprising a pair of opening jaws 55, 56, means for feeding one cover at a time from said magazine between said jaws when open, means, as the cams 100, 101, acting upon said jaws to close the same while the box is being inserted thereinto by the movement of said belt and then to release the covered box, a stationary arm or bracket 62 passing through one of said jaws and adapted to hold one edge of the cover up within the jaws until the jaws close, a vertically movable presser wheel 61 adapted to press the opposite edge of the cover downward within the jaws, whereby the jaws in closing press diagonally opposite edges of the tubular cover to shape the cover to fit the interior of the jaws, and the webs *u u* upon said jaws for retaining the opened cover therein while the box is being inserted thereinto, substantially as described. 14th. The combination, in a packing-machine, of a magazine M for box-blanks, means for folding the sides of said blanks to partially form boxes, a magazine N for cigarettes, a rod 78 reciprocating longitudinally of the machine, a belt A moving under said magazine and provided with means for moving said blanks therewith, a pusher 30 co-operating with said belt for starting the blanks successively from said magazine M, a plunger N<sup>1</sup> attached to said rod for discharging successive charges of cigarettes from said cigarette magazine into the boxes as they pass thereunder, means for folding the side flaps of the blank to form the sides of the box, a folder 38 for lifting and folding the forward flaps of the blanks, lugs upon said rod for actuating said folder, means for folding the rear flap of said blank to complete the folding of the box, a cover-holder for holding covers in line with the movement of said box upon said belt, a cover-magazine P adjacent to said cover-holder and above said belt and in line therewith, and a plunger 54 attached to said rod for feeding one cover at a time from said magazine into said cover-holder, substantially as described. 15th. The combination, in a machine for folding box-blanks having flaps 20, 21 and 22 substantially as described, of a channel wherein said blanks move in succession having side guides *u* with inclined faces gradually approaching the vertical position for folding the flaps 22, a folder 41 attached to the devices for moving said blank in said channel for folding the flap 20 to the vertical position, the lifting folder 38 for lifting the flap 21 to the vertical position and then for folding

said flap down, the arms 42 interposed in the path of movement of the vertical flap 20, the toothed wheels 43 revolving peripherally in the same direction as the movement of the blank and adapted to engage the flap 20 and to fold the same down, a reciprocating rod 78 operating in time with the devices for moving the blank in said channel, the stops 91, 92 upon said rod, the shaft 40 bearing the folder 38 and the arm 42, the arm 93 attached to the shaft 40 and adapted to be engaged successively by said stops, and the spring pressed arm 94 adapted to engage said arm 93 and to hold the same in the position to which either of said stops move it until moved by the other of said stops, substantially as described.

**No. 57,541. Bottle Stopper. (Bouchon de bouteille.)**

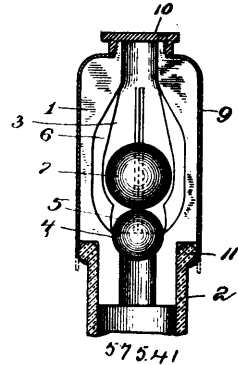

Fred Alston Cooke, Boston, Mass., U.S.A., 23rd September, 1897; 6 years. (Filed 10th September, 1897.)

*Claim.*—1st. In a stopper, the combination, substantially as set forth, of a block made in two parts secured together, a cavity in said stopper open at both ends and tapering toward those ends, a hemispherical depression in the bottom of the cavity, a movable ball-valve seating itself against the bottom of the depression, a series of ears projecting on the inside of the cavity, starting from near the depression, widening to form a contraction less than the diameter of the ball-valve, and then narrowing toward the top of the cavity, and a second ball moving in the cavity above the ball-valve and acting to force the ball-valve closely against its seat. 2nd. The combination, substantially as described, with the described stopper, of a case enclosing the stopper, and projecting beyond the lower end of the same, to cover the flange on the neck of the bottle into which the stopper is inserted, and an opening in the top of the case through which the top of the stopper passes.

**No. 57,542. Adjustable Window Screen. (Store de fenetre.)**

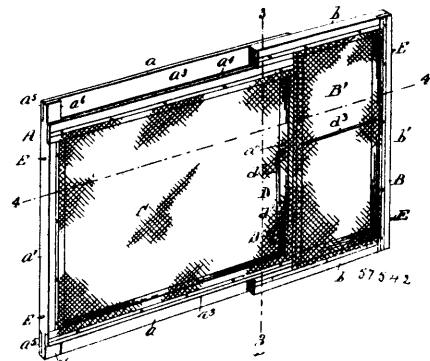

James E. Symes, Bancroft, Michigan, U.S.A., 23rd September, 1897; 6 years. (Filed 16th September, 1897.)

*Claim.*—1st. In an adjustable window screen, the combination of a main frame, a movable wing frame adjustably mounted on the main frame, screen fabric engaged with both said frames, a spring connected with the main frame at one side the longitudinal centre of the end piece, of the main frame adjacent to the wing frame, said spring formed with an outer arm passed through said end rail of the main frame and connected with the end rail of the wing frame, substantially as set forth. 2nd. In an adjustable screen, the combination of a main frame carrying a screen fabric, a wing frame carrying a screen fabric and movably mounted on the main frame, a spring mounted on the end rail of the main frame adjacent to the

wing constructed with a laterally extended yielding arm adjacent to the inner surface of the end rail of the main frame when the wing frame is in a fully extended position, said spring formed with a right angled end portion passed through the adjacent end rail of the main frame and engaged with the end rail of the wing frame, the inner surface of the main frame and of the wing frame located in essentially the same plane, the end rail of the main frame carrying said spring provided with an orifice to receive the outer arm of the spring and serving to guide and hold said arm, substantially as described. 3rd. In an adjustable window screen, the combination of a main frame, a movable wing frame adjustably mounted on the main frame, screen fabric engaged with both said frames, and a spring mounted on the inner edge of the end bar of the main frame adjacent to the wing frame, provided with a laterally extended yielding arm, and an outer arm extended at a right angle to said lateral arm and passed through the adjacent end bar of the main frame, said outer arm of the spring engaged with the end bar of the wing frame, whereby said wing frame is yieldingly held in extended position, the lateral arm of the spring serving as a stop when the wing frame is fully extended, substantially as set forth. 4th. In an adjustable window screen, the combination of a main frame, a movable wing frame adjustably mounted on the main frame, screen fabric engaged with both said frames, the side bars of the main frame cut away longitudinally on their outer edges, and each provided with an inwardly projecting longitudinal channel, the side bars of the wing frame made narrower than the corresponding bars of the main frame both vertically and laterally, and formed with a longitudinal tongue on their inner edges projecting into the corresponding groove of the main frame, the inner surfaces of the main and wing frames being substantially in the same plane, for the purpose set forth.

**No. 57,543. Cigarette Manufacturing Machine.**  
(Machine à faire les cigarettes.)

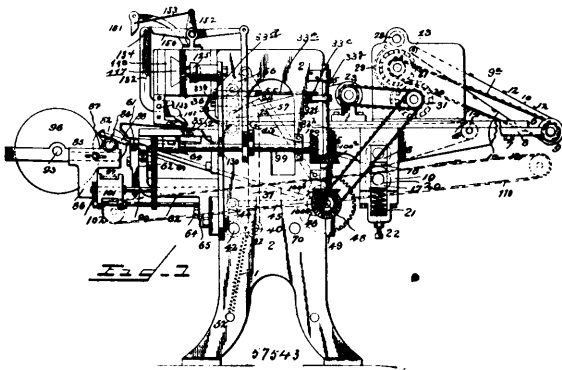

George Henry Hilgartner, Richmond, Virginia, U.S.A., 23rd September, 1897; 6 years. (Filed 10th August, 1897.)

*Claim.*—1st. In a cigarette machine, the combination with the tobacco feeding, shearing, and rolling devices, of a dropper located below the shearing device to collect the sheared tobacco and deposit it in bulk upon the apron of the rolling device, substantially as and for the purpose set forth. 2nd. A machine for making cigarettes, comprising endless feed belts 10, 10<sup>a</sup>, a series of picking rollers located in the path of said belt 10, an endless compacting belt located at an inclination above belt 10<sup>a</sup>, a cutter blade crossing the path of the tobacco, which abuts against said blade while it is being pressed by the feed belt 10<sup>a</sup> and compacting belts, a pair of vertically reciprocating arms carrying said cutter blade and mounted in guide brackets secured to the bed plate, a transverse rod connecting the lower ends of said arms, a pair of levers having their free ends hinged to said transverse rod, and fulcrumed on a rockshaft, a vertical lever likewise fulcrumed on said shaft a connecting rod, one end of which is pivoted to the free end of said vertical lever and having a friction roller secured to one side of its opposite forked end, and a cam fixed on a driving shaft and adapted to engage said forked end to impart an intermittent vertical reciprocating movement to said cutter blade, substantially as and for the purpose set forth. 3rd. A machine for making cigarettes, comprising endless feed belts 10, 10<sup>a</sup>, an endless compacting belt located at an inclination above said feed belt 10<sup>a</sup>, a series of picking rollers located in the path of the feed belt 10, a cutter blade crossing the path of the tobacco, which abuts against said blade while it is being pressed by the feed belt 10<sup>a</sup> and compacting belts, and means substantially as described for operating the same, in combination with a cigarette rolling table, a rod mounted in the lower ends of a pair of oscillating levers fulcrumed in the frame of the machine, a roller apron, one end of which is secured to said table and the other to the rod, a reciprocating carriage, a lever fulcrumed in the frame, a connecting rod connecting the free end of said lever with said carriage, a cam mounted on the driving shaft and in operative contact with said lever, the cigarette rolling head

of said carriage being formed with a recess adapted to engage a pocket in said roller apron containing a charge of tobacco, and form the same into a roll during its passage across the cigarette rolling table, as and for the purpose set forth. 4th. A machine for making cigarettes, comprising a cigarette rolling table, a pair of oscillating levers, a rod mounted in said levers, a rolling apron connected at one end to the cigarette rolling table and the other end to the rod, a reciprocating carriage having a cigarette rolling head formed with a recess, plungers, a retractile spring located at each end of said recess in said head, and a pair of stationary converging rails located in the path of said head, as and for the purpose set forth. 5th. In a cigarette making machine, the combination with the conveying cylinder, the rotating cutters and the conveyer belt located in a frame immediately below said cylinder, a series of circumferentially grooved feed rollers journaled in said frame, and an arm against which one end of the finished cigarette abuts, of an upwardly inclined elevator belt provided with fingers adapted to take the finished cigarette from the feed rollers, substantially as and for the purpose set forth. 6th. In a cigarette making machine, the cigarette forming and rolling devices substantially as described, in combination with a pair of continuously operated feed rollers, having oppositely arranged cut-away portions, an intermittently operated paste roller, adapted to travel to and from the paper, a travelling carriage having a stationary jaw and a movable finger adapted to clamp the paper against said jaw, and a paper cutting device located between the paste roller and the clamping finger, and adapted to sever a section of the pasted paper, as and for the purpose set forth. 7th. In a cigarette machine, the endless feed belts provided with cross strips, the stationary rollers and the adjustable tension roller upon which one of said feed belts is mounted, in combination with the compacting belt mounted on rollers at an inclination to one of said endless feed belts, the picking rollers located in the path of the other feed belt, the cutter blade crossing the path of the tobacco which abuts against said blade while it is being fed forward, the vertical reciprocating arms on which said blade is mounted, the driving shaft and the cam mounted on said driving shaft and adapted to intermittently operate said arms and cutter blade, as and for the purpose set forth. 8th. In a cigarette making machine, a cigarette forming device, consisting of the rolling table 59, the apron 35, the oscillating arms 54, the rod 53 mounted in said arms, in combination with the carriage 67, the cigarette rolling head 73, formed with a recess 75, spring actuated plungers located in said cigarette rolling head at each end of said recess, and a pair of inwardly converging rails located in the path of said plungers, as and for the purpose set forth. 9th. In a cigarette machine having cigarette rolling, wrapping and trimming devices, substantially as described, the combination with the frame 101 extending at a right angle to the delivery end of the machine proper, the endless chain 97 mounted in said frame, the series of grooved rollers 105 journaled in the outer end of said frame, the inclined frame 109 located at a right angle to the frame 101 and extending upwardly and forwardly to a point within reach of the attendant at the front of the machine, the endless belt 110 provided with a series of fingers 114 and mounted in said inclined frame 109, substantially as and for the purpose set forth. 10th. In a cigarette making machine having a cigarette rolling and wrapping device substantially as described, the combination with a pair of continuously operated paper feed rollers having cut-away portions, the shaft 163, the arm 172, the paste roller mounted in said arm, the pressure finger 179, and arm 178 mounted on said shaft, a cam mounted on the shaft of one of said paper feed rollers and adapted to cause the paste roller and pressure finger to alternately travel to and from the paper, of the travelling carriage 120, the stationary jaw 144 and pivoted finger 145 mounted on said carriage, the lever 127, and the pitman 125 connecting said carriage and lever, the cam 130, and the shaft 99 on which said cam is mounted, and means substantially as described for operating the same, as set forth. 11th. In a cigarette making machine, comprising the pair of continuously operated feed rollers, the paste receptacle having an opening in its bottom, the arm 172, the paste roller 191 mounted in said arm and adapted to travel from the opening in the bottom of the paste receptacle to the paper on the bed of the machine, the arm 178 and the pressure finger 179, the shaft 163 on which said arms and pressure finger are mounted, a pair of feed rollers having cut-away portions, the cam 181 mounted on the shaft of one of said feed rollers, the stationary shear blade 200, the blade 201 pivoted thereto, and the spring 202 connecting said blades, in combination with the lever 206, the roller 205 mounted in said lever, the pitman 208 connected to said lever, a countershaft and a cam mounted on said countershaft and adapted to operate the pivoted blade through the medium of said pitman and lever, substantially as and for the purpose set forth.

**No. 57,544. Gas Engine. (Machine à gaz.)**

Daniel Best, San Leandro, California, U.S.A., 23rd September, 1897; 6 years. (Filed 18th August, 1897.)

*Claim.*—1st. A device for producing an explosive gas from hydrocarbon liquid, consisting of a series of superposed shallow pans, pipes extending upwardly through openings in the pans and connecting with an engine cylinder or cylinders, passages through which the hydrocarbon liquid is supplied from above to each of the pans and through which air also passes from above downwardly, said passages consisting of openings made in the pans at one side of the centre thereof, said openings being alternately upon opposite

sides of the adjacent pans and having upwardly projecting rims whereby a body of oil is retained in each of the pans, and a means

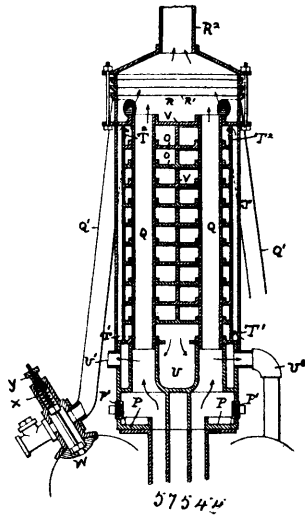

for supplying air from above to be drawn through said openings, and connections at the bottom with the engine cylinders. 2nd. A device for producing an explosive gas or vapour from hydrocarbon liquid, consisting of a series of shallow superposed pans each having an opening at one side of the centre of the pan, with said openings alternately at opposite sides of adjacent pans, said openings having upwardly projecting rims whereby a body of hydrocarbon liquid is retained in each of the pans, pipes extending upwardly through openings in said pans, transverse partitions extending partially across the space in each pan, forming a tight joint therewith at the bottom and extending up to the top, an outer jacket or casing surrounding the pans and forming an annular chamber around them, air inlets at the bottom of the casing through which air is admitted thereto, other passages through the uppermost of the oil-containing pans through which the air is admitted to the interior of the pans, passages connecting the lowermost of the pans with an engine, cylinder or cylinders so that the forward motion of the piston will draw a charge of air through the open passages in the pans, said air being charged with the vapour so as to form an explosive compound which is admitted through the inlet valves into the cylinders with the strokes of the piston, and exhaust passages connecting with the pipes which extend upwardly through the pans so as to heat and vaporize the contents to be mixed with air. 3rd. In a carburetor for gas engines, the combination of a series of superposed pans having flanged openings made alternately at opposite sides of the pans, intermediate partitions extending across the pan from nearly one side to the other forming a close joint at the bottom with the pan and extending close up to the top thereof, whereby the air passing through the openings is distributed over the surface of the liquid in the pans, a surrounding casing with air inlets delivering air into the uppermost of the pans, connections between the lowermost pan and the engine cylinders whereby the explosive gas or vapour is drawn into the cylinders by the strokes of the piston, exhaust passages upon each cylinder with pipes extending upwardly through the pans whereby the contents are heated and vaporized when the engine is in operation, supplemental fire-places situated below the pans and adapted to receive the fuel so that the apparatus may be heated before starting the engines.

**No. 57,545. Plane. (Rabat.)**

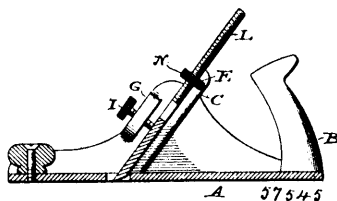

Charles August Paul, Orlando, Oklahoma, U.S.A., 23rd September, 1897; 6 years. (Filed 20th August, 1897.)

*Claim.*—1st. In a plane, the combination with a plane body, of inclined bit-slides securely fastened thereto, a bit having screw-threaded arms located at opposite sides thereof and secured thereto, and nuts carried on said arms and engaging the bit-slides, whereby either or both sides of the bit can be adjusted. 2nd. In a plane,

the combination with a plane body, of inclined bit-slides secured thereto, said slides being provided with notches, a bit movable upon the slides and having screw-threaded arms secured thereto and located at opposite sides thereof and circular nuts carried on the arms and loosely received in the notches. 3rd. In a plane, the combination with a plane body, of inclined bit-slides securely fastened thereto, said slides being provided with notches, a bit movable on the slides and having screw-threaded arms at its opposite sides, nuts carried on the arms and loosely received in the notches, ears secured to the plane body, and clamping screws passing through the ears and binding on the bit. 4th. In a plane, the combination with a plane body, of bit-slides secured to the body, a bit movable on said slides, said bit being provided with integral screw-threaded arms L and M, circular nuts N and O, loosely received on the bit-slides, and clamping screws I and J, adapted to bind on the bit-slides. 5th. The combination with the plane stock having its sides provided with rearwardly inclined bit-slides and arc-shaped notches at their upper ends and lugs projecting inwardly from the inner walls of the opposite sides, of a bit mounted for movement in said slides beneath said lug and provided with integral upwardly projecting screws, one at each edge, nuts on said screws projecting into said notches and set-screws passed through said inwardly extending lugs at right angles to the screws and bearing against the bit whereby the bit may be adjusted in either direction by manipulation of said nuts and also tilted to either the right or left to bring the cutting edge thereof parallel with the bottom of the plane, substantially as described.

**No. 57,546. Apparatus or Machine for Shaping or Forging and Sharpening Rock Drills, etc. (Appareil ou machine à former ou aiguiser les forets.)**

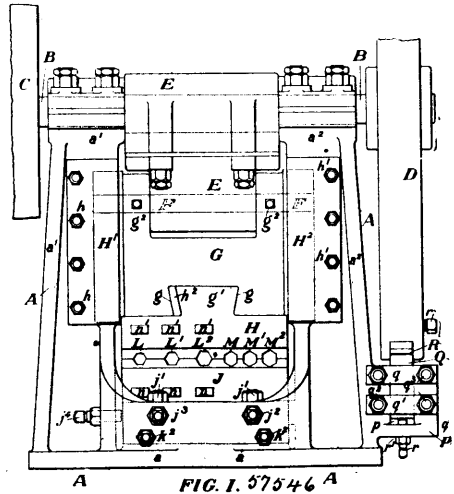

Stephen Pearce Quick, Johannesburg, South African Republic, 23rd September, 1897; 6 years. (Filed 18th August, 1897.)

*Claim.*—1st. A die for shaping or forging and sharpening rock drills and like tools, in which is fitted a cutter for effecting the sharpening or formation of the extreme cutting edge on the drill or tool simultaneously with the formation of the tapering or angular faces thereof, substantially as described. 2nd. A die for shaping or forging and sharpening rock drills and similarly-shaped edge tools, fitted with an inclined cutter so disposed or arranged as to constitute that portion of the die which effects the formation of the extreme cutting edge on the drill simultaneously with the formation of the tapering or angular faces, said cutter being set at such an inclination as to form the desired bevel at the cutting point of the drill, in addition to the cutting edge, substantially as described. 3rd. In combination, the die for forging or shaping and sharpening rock drills and like tools, the adjustable inclined cutter, constituting a portion of the die, slightly rounded and bevelled to form the slightly rounded and bevelled cutting edge on the drill, simultaneously with the formation of the tapering or angular faces thereon, substantially as described. 4th. A die block, in which is sunk or fitted a die for shaping or forging and sharpening rock drills and the like, provided with an inclined slot projecting into, or terminating at one end of, the die, in which is fitted a removable cutter constituting that portion of the die which effects the sharpening or formation of the extreme cutting edge on the drill, substantially as described. 5th. In combination, a die block, a die sunk or fitted therein for shaping or forging the tapering or angular faces on rock drills and like tools, an inclined slot formed in the die block projecting into said die, a cutter arranged therein and forming that portion of the die which effects the sharpening or formation of the extreme cutting edge on the drill, a further slot formed in the die block, intersecting the inclined slot in which the cutter is arranged, and an adjusting

wedge or tapered bolt fitted within this further slot and bearing against the end of the cutter for effecting any required adjustment thereof, substantially as described and shown. 6th. In machines or apparatus for shaping or forging and sharpening rock drills and the like, the combination of upper and lower die blocks, to the upper one of which a vertical reciprocating or up-and-down motion is imparted in any suitable manner, the die blocks being sunk or fitted with one or more dies for effecting the shaping and sharpening of drills or tools on their tapering or angular faces, said die or dies being fitted or provided with an adjustable cutter or cutters for forming the extreme cutting edge on the drill simultaneously with the formation of the angular faces, and with one or more dies for forming the drill on its slightly spreading sides or edges, and finishing same to gauge, substantially as described and shown. 7th. In machines or apparatus for shaping or forging and sharpening rock drills and the like, the combination of upper and lower die blocks, to the upper one of which a vertical reciprocating or up-and-down motion is imparted in any suitable manner, the die blocks being sunk or fitted with one or more dies for effecting the shaping and sharpening of drills or tools on their tapering or angular faces, said die or dies being fitted or provided with an adjustable cutter or cutters slightly rounded and bevelled, and set at such an inclination in the blocks as to form the desired level at the cutting point and the slightly rounded and bevelled cutting edge of the drill, simultaneously with the formation of the tapering and angular faces thereof, substantially as described. 8th. In machines or apparatus for shaping or forging and sharpening rock drills and like tools, the combination of the upper and lower die blocks H, J, in which are sunk or fitted the set or series of dies M, M<sup>1</sup>, M<sup>2</sup> for forming the tapering or angular faces of the drill, the inclined slots or holes *l*, *l*<sup>1</sup> formed in the die blocks and terminating at the inner ends of the dies, the cutters *m*, *m*<sup>1</sup> fitted within the slots *l*, *l*<sup>1</sup> and constituting the innermost portion of the dies, the slots or holes *o*, *o*<sup>1</sup> formed in the die blocks and intersecting the slots *l*, *l*<sup>1</sup>, the wedges or tapered bolts *n*, *n*<sup>1</sup> fitted in slots *o*, *o*<sup>1</sup>, and bearing upon the extremities of the cutters *m*, *m*<sup>1</sup> for adjusting same as may be desired, and a rest or stop O, substantially as described and shown. 9th. In machines or apparatus for shaping or forging and sharpening rock drills and the like, the combination of an adjustable, normally-stationary cutter, supported by a bracket or extension of the frame of the machine working in conjunction with a corresponding adjustable cutter fitted to the rim or periphery of the fly-wheel for shearing off the burr or fine edge or strip of metal left on the cutting edge of the drill or tool after it has been passed through the dies, substantially as described. 10th. In machines or apparatus for shaping or forging and sharpening rock drills and the like, the combination of the bracket or extension P of the frame, the slot *p* formed therein, the slightly rounded and bevelled cutter Q fitted within slot *p*, the straps or bars *q*, *q*<sup>1</sup> affixed to the bracket P and securing cutter Q in position in the slot *p*, the adjusting screw *r* for the cutter Q, the fly-wheel D, the slot *d* formed in the rim or periphery thereof, the cutter R fitted within the slot *d*, the retaining stud *r*<sup>2</sup> and adjusting screw *r*<sup>3</sup> for the cutter R for shearing off the burr or fine edge or strip of metal left on the cutting edge of the drill or tool after it has been passed through the dies, substantially as described and shown. 11th. In machines or apparatus for shaping or forging and sharpening rock drills and the like, the combination of the frame A of the machine, comprising the base *a* and the standards or pedestals *a*<sup>1</sup>, *a*<sup>2</sup>, the shaft B journaled therein, the driving pulley C, the fly wheel D, the cross-head G working in guides or recesses formed on the inside of the pedestals *a*<sup>1</sup>, *a*<sup>2</sup>, and coupled up with the driving shaft B by means of an eccentric, crank or other suitable device to impart a vertical reciprocating or up-and-down motion thereto on the rotation of the shaft, the recess *g* formed in the cross-head G, on the underside, the upper die block H, the projection *a*<sup>1</sup> fitting and secured within the recess *g*, the dies M, M<sup>1</sup>, M<sup>2</sup> sunk or fitted within the die block H, the inclined cutters *m*, *m*<sup>1</sup>, the adjusting wedges or tapered bolts *n*, *n*<sup>1</sup>, the stops or rests O, the dies L, L<sup>1</sup>, L<sup>2</sup> sunk or fitted within die block H, the lower die block J, the dies M, M<sup>1</sup>, M<sup>2</sup> sunk or fitted therein, the inclined cutters *m*, *m*<sup>1</sup>, the adjusting wedges or tapered bolts *n*, *n*<sup>1</sup>, the dies L, L<sup>1</sup>, L<sup>2</sup> sunk or fitted within die block J, the tapered or inclined under-surface *j* of the die block J, the adjusting wedge K fitted within the base *a*, upon which block J rests, the holding and adjusting screws or studs *j*<sup>2</sup>, *j*<sup>3</sup>, *j*<sup>4</sup>, *k*<sup>1</sup>, *k*<sup>2</sup> for the wedge K, and the holding-down bolts *j*<sup>1</sup> for the lower die block J, substantially as described and shown. 12th. In machine or apparatus for shaping or forging and sharpening rock drills and the like, the combination of the frame A, comprising the base *a* and the standards or pedestals *a*<sup>1</sup>, *a*<sup>2</sup>, the eccentric shaft B journaled therein, the driving pulley C, the connecting rod E, the cross-head G, the pin F, the screws or studs *g*<sup>2</sup>, the retaining plates H<sup>1</sup>, H<sup>2</sup> affixed to the pedestals *a*<sup>1</sup>, *a*<sup>2</sup>, the recess *g* formed in the cross-head G on the underside, the upper die block H, the corresponding projection *a*<sup>1</sup> formed thereon and fitting within the recess *g*, the wedge or tapered key *h*<sup>2</sup>, the dies M, M<sup>1</sup>, M<sup>2</sup> sunk or fitted within die block H, the inclined cutters *m*, *m*<sup>1</sup>, the adjusting wedges or tapered bolts *n*, *n*<sup>1</sup>, the stops or rests O, the dies L, L<sup>1</sup>, L<sup>2</sup> sunk or fitted within die block H, the lower die block J, the dies M, M<sup>1</sup>, M<sup>2</sup> sunk or fitted therein, the inclined cutters *m*, *m*<sup>1</sup>, the adjusting wedges or tapered bolts *n*, *n*<sup>1</sup>, the dies L, L<sup>1</sup>, L<sup>2</sup> sunk or fitted within die block J, the tapered or inclined under-surface *j* of the die block J, the adjusting wedge K fitted within the base *a*, upon which

block J rests, the holding and adjusting screws or studs *j*<sup>2</sup>, *j*<sup>3</sup>, *j*<sup>4</sup>, *k*<sup>1</sup>, *k*<sup>2</sup> for the wedge K, and the holding-down bolts *j*<sup>1</sup> for the lower die block J, the bracket or extension P of the frame A, the slot *p* formed therein, the cutter Q fitted within slot *p*, the straps or bars *q*, *q*<sup>1</sup> affixed to the bracket P and securing cutter Q in position in the slot *p*, the adjusting screw *r* for the cutter Q, the fly-wheel D, the slot *d* formed in the rim or periphery thereof, the cutter R fitted within the slot *d*, the retaining stud *r*<sup>2</sup> and adjusting screw *r*<sup>3</sup> for the cutter R, substantially as described and shown.

**No. 57,547. Stocking. (Bas.)**

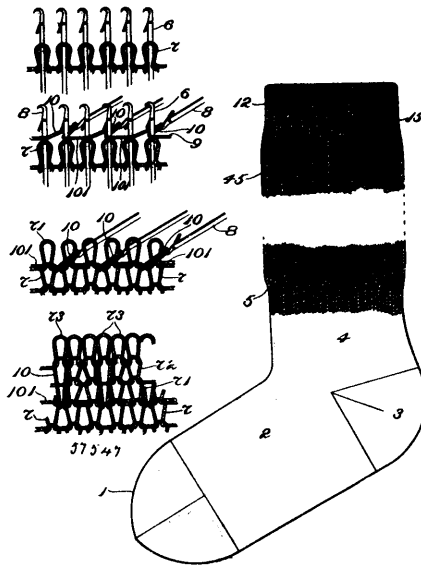

William Esty, Laconia, New Hampshire, U.S.A., 23rd September, 1897; 6 years. (Filed 6th August, 1897.)

*Claim.*—1st. The improved knitted fabric composed of plain goods in its lower portion, and of ribbed goods in its upper portion, and with unbroken courses of loops where the change from plain to ribbed goods is made, with a welting course 9 of such yarn or thread in the upper part of the plain goods having loops thereof engaging the connecting portions of yarn which join the loops of a course of the plain goods, such loops of the welting course being drawn up behind a course or courses of the plain goods and constituting the starting of the loops of the ribs. 2nd. The improved knitted fabric composed of plain goods in its lower portion and of ribbed goods in its upper portion, and with unbroken courses of loops where the change from plain to ribbed goods is made, with a welting course 9 of such yarn or thread in the upper part of the plain goods having loops thereof engaging the connecting portions of yarn which joins the loops of a course of the plain goods, such loops of the welting course being drawn up behind a course or courses of the plain goods and constituting the starting of the loops of the ribs, and also being shogged. 3rd. The improved knitted fabric composed of plain goods in its lower portion and of ribbed goods in its upper portion, having near the upper edges of the plain goods loops drawn from between the regular loops of such goods to the reverse of the fabric, such loops being drawn up behind a course or courses of the plain goods, and constituting the starting loops of the ribs, and also being shogged. 4th. A stocking or the like having the upper portion thereof knit in ribbed goods and finished with a hem knit in plain goods, the final portion of such hem being knit in ribbed goods and united to the reverse side of the stocking by the last loops pertaining to the ribs in said upper portion of the stocking, such final portion of the web having a trimmed edge on such reverse side which is secured by being fastened off. 5th. The improved stocking composed of knit fabric ravelling from the top downward, and composed of a plain seamless foot portion and a ribbed leg portion, both formed of continuous yarn or thread with unbroken and uninterrupted courses of loops where the change from plain goods to ribbed goods is made, and without eyelets or supplemental yarn or thread at such place.

**No. 57,548. Piano Tuning Pin.**

(*Tendeur-accordeur pour pianos.*)

Richard McMillan, Kingston, Ontario, Canada, 23rd September, 1897; 6 years. (Filed 20th July, 1897.)

*Claim.*—1st. The combination with the wrest plate A, having a screw-threaded hole terminating in a contracted conical bore, of the turning-pin D, having a cone-shaped enlargement fitted to said bore and a plug E, screwing into said hole and impinging the base of the cone, as and for the purpose set forth. 2nd. A pianotuning-



pin having a circumferential enlargement D', and provided with a screw thread and nut G, substantially as and for the purpose set

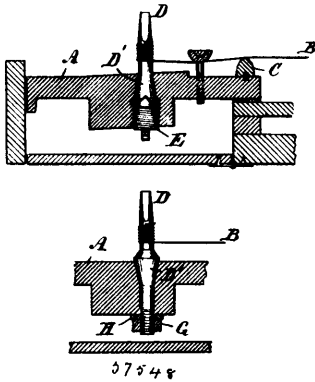

forth. 3rd. The combination of the wrest plate A, having a bore and conical enlargement, and a tuning-pin fitting therein, and provided with a nut screwing thereon and against the under face of the wrest plate, substantially as set forth.

**No. 57,549. Manure Spreader.**

(Machine pour distribuer le fumier.)

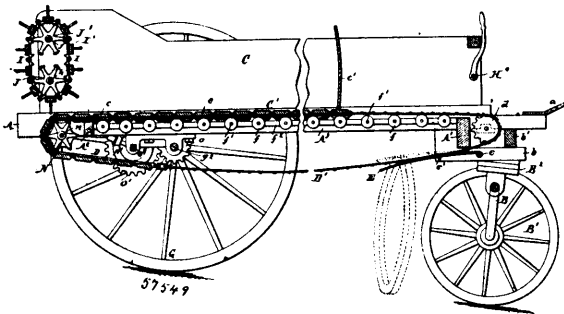

Joseph S. Kemp, Syracuse, New York, U.S.A., 23rd September, 1897; 6 years. (Filed 7th September, 1897.)

*Claim.*—1st. The combination with the body frame and the movable slat bottom, of a longitudinal series of supporting rollers arranged centrally in the frame, and a central series of links secured to the under sides of the bottom slats and provided with depending side flanges which embrace said rollers, substantially as set forth. 2nd. The combination with the rear axle and the beater shaft, of a wheel whereby the beater shaft is driven and which is provided with a clutch face and a sleeve projecting beyond the clutch face, a fixed arbor on which said wheel and sleeve turn, and a driving pinion mounted to slide on said sleeve and provided with a clutch face adapted to engage the clutch face of said wheel, substantially as set forth. 3rd. The combination with the rear axle and the driving wheel secured thereto, of a fixed arbor arranged in rear of said axle, a sprocket wheel mounted to turn on said arbor and having a clutch face and a sleeve projecting beyond said face, a pinion mounted to slide on said sleeve and meshing with said driving wheel and having a clutch face engaging with that of said sprocket wheel, and a beater driven from said sprocket wheel, substantially as set forth. 4th. The combination with the rear axle and the driving wheel secured thereto, of a fixed arbor arranged in rear of said axle and provided in its upper side with a longitudinal oil groove which opens at the outer end of said arbor, a sprocket wheel which is provided with a sleeve mounted to turn on said arbor and with a clutch face at the inner end of said sleeve, an oil cup opening into the oil groove of the arbor, a pinion mounted to slide on said sleeve and provided with a corresponding clutch face, and a beater driven from said sprocket wheel, substantially as set forth. 5th. The combination with the rear axle and the driving wheel secured to the same, of a lower beater shaft which is driven from said driving wheel and supported in bearings which are held against vertical movement, an upper beater shaft which is supported in vertically adjustable bearings, and an endless apron beater mounted on said shafts, substantially as set forth. 6th. The combination with the lower beater shaft, driving mechanism whereby said shaft is rotated, and spiders secured to said shaft, of a fixed upper beater shaft, spiders which are capable of rotative movement and longitudinal movement on said fixed shaft, endless chains applied to said spiders, and toothed beater slats secured to said chains, substantially as set forth. 7th. In a manure spreader, the combi-

nation with the box and its movable bottom, and the transverse beater shafts and their spiders arranged at the rear end of said box, of an endless apron beater consisting of endless chains, and transverse toothed slats, each chain link being secured to one of the slats, whereby the slats are held against tilting, substantially as set forth. 8th. The combination with the beater spiders having their arms provided with end cross bars and having centre lugs on both sides of each cross bar, of beater chains composed of flat links having at one end a pair of prongs which straddle said lugs, substantially as set forth. 9th. The combination with the uprights and the adjustable bearing of the beater shaft arranged between the same, of a vertical adjusting screw whereby said bearing is adjusted, and a locking arm which straddles one of said uprights and which grasps the head of the adjusting screw, substantially as set forth. 10th. The combination with the uprights, and a cross bar secured between the same and provided with a screw-threaded opening, of a vertical adjusting screw passing through said opening and having a head at its lower end, a locking arm having an opening through which said screw passes and provided with claws which embrace the screw-head and at its opposite end with prongs which straddle one of said uprights, and a bearing which rests upon said screw, substantially as set forth.

**No. 57,550. Bolt Protector.** (Protecteur de boulon.)

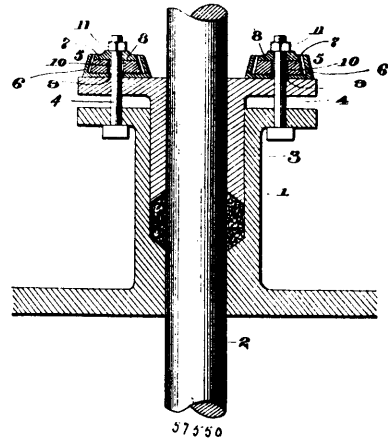

Lyman Trumbull Lowe, Guston, Colorado, U.S.A., 23rd September, 1897; 6 years. (Filed 16th September, 1897.)

*Claim.*—1st. A bolt protector comprising a containing casing, an expansible washer mounted in said casing and formed with a bolt receiving aperture, and a cap mounted about the bolt and over said washer and secured down in position by the nut mounted on said bolt, substantially as described. 2nd. In a bolt protector, the combination with a cup shaped casing, of an expansible washer mounted therein, and having a bolt receiving aperture, and a cap also provided with a bolt aperture and mounted above said washer so as to be engaged by the nut mounted upon said bolt, substantially as described. 3rd. In a bolt protector, the combination with a cup shaped casing having a central aperture in its bottom, of an expansible washer mounted in said casing and of less diameter than the same, and provided with a central aperture of greater diameter than the bolt, and a cap also formed with a bolt aperture and adapted to rest upon the top of the expansible washer and to be secured down in position by the nut upon said bolt, substantially as described.

**No. 57,551. Thill Coupling.** (Armon de limonière.)

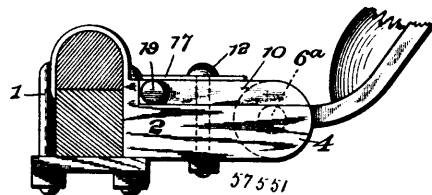

James E. Cryderman, Troy, and Curtis Johnson, River Falls, both in Wisconsin, U.S.A., 23rd September, 1897; 6 years. (Filed 9th July, 1897.)

*Claim.*—1st. In a thill coupling, a base plate, ears projecting outward therefrom, said ears having half bearing formed on their inner sides, spring pressed jaws pivoted to the plate and extending forward completing the upper portion of the bearings, and thill iron having pivotal pins formed on opposite sides thereof, substantially as and for the purpose described. 2nd. In a thill coupling, a base

plate, ears projecting outward therefrom, said ears having half bearings formed on their inner sides, spring pressed jaws pivoted to said plate and extending forward completing the upper portion of said bearings, said jaws having slots formed therein with slanting bottom walls directly above the bearings, and a thill iron having pivotal pins to fit in said bearings, substantially as described. 3rd. In a thill coupling, a base plate, ears projecting outward therefrom, said ears having half bearings formed on their inner sides, jaws pivoted to said plate and extending forward completing the upper portion of said bearings, said jaws having slots with slanting bottom walls directly above the bearings, a lug formed on the plate between the jaws, a spring pressing the rear part of said jaws outward, and a plate covering the space left between the jaws, substantially as described.

**No. 57,552. Fastening Device. (Appareil à assujétir.)**

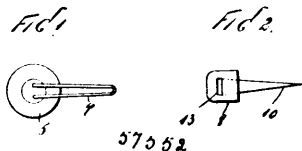

Cornelius Weggandt Garis, Easton, Pennsylvania, U.S.A., 23rd September, 1897; 6 years. (Filed 7th September, 1897.)

*Claim.*—1st. A fastening device consisting of two parts, one of which is provided with a head in which is formed an opening, and to the bottom of which is secured a shank which is provided with an arm which projects at right angles thereto, and the other part consisting of a head which is also provided with a shank, on which is formed an arm which projects at right angles thereto, said arm and said shank being adapted to pass through said opening, substantially as shown and described. 2nd. The herein described fastening device, comprising two parts, one part of which consists of a head 5, shank 6 and arm 7, the other part consisting of a head 8, shank 9, and arm 10, said head 8 being provided with an opening 13, substantially as and for the purpose described.

**No. 57,553. Bed. (Lit.)**

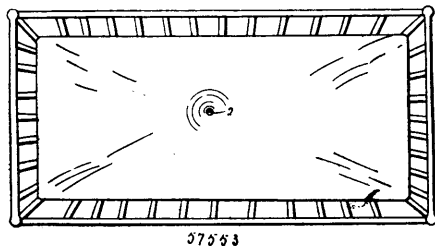

Joseph John O'Connor, Montreal, Quebec, Canada, 23rd September, 1897; 6 years. (Filed 28th August, 1897.)

*Claim.*—1st. A child's bed or the like, having an impervious sheet perforated about centrally thereof, a tube or conductor leading from said perforation and communicating with a receptacle, for the purpose set forth. 2nd. A child's bed or the like, having an impervious sheet, perforated about centrally thereof, a mattress having an opening or passage adapted to register with said perforation in the sheet, a tube or conductor leading from said perforation, passed through the opening in the mattress and communicating with a receptacle, for the purpose set forth. 3rd. A child's cradle or other oscillating bed having an impervious sheet perforated about centrally thereof, a mattress having an opening or passage adapted to register with said perforation, a tube or conductor leading from said perforation, passed through the opening in the mattress and communicating with a receptacle in the form of a pail hung from the bottom of the cradle and having its upper end diminished, for the purpose set forth.

**No. 57,554. Adjustable support for Invalids.**

(Support pour lits d'invalides.)

Winfield Harbaugh, Alameda, California, U.S.A., 23rd September, 1897; 6 years. (Filed 26th August, 1897.)

*Claim.*—1st. In an article of the class described, the combination with a back-rest, of a series of members so arranged and secured to said back-rest in such a manner, that by changing the inclination of said members, the position of said back-rest can be changed without changing its inclination, while the inclination of said back-rest can be accomplished without changing the position or inclination of said members, and means for firmly locking said rest at any angle or any shifted position for the purpose set forth. 2nd. In an article of the class described, the combination with a back-rest, of a series of members hinged to said back-rest, adjustable locking means be-

tween said rest and said members, and by means of which said rest can be advanced or retracted and firmly locked in the same or a dif-

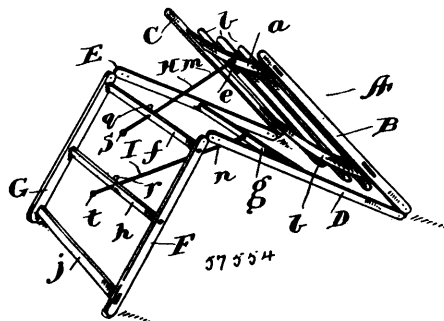

ferent angle of inclination, said locking means being further adapted to adjust the angle of inclination of said rest without changing the position of said members. 3rd. In an article of the class described, the combination with a back-rest, of a plurality of members connected to said rest, a plurality of adjustable locking devices positioned on said article, one of said devices being adapted to adjust the angle of inclination of said rest and firmly hold it in said position, while the other device is adapted to advance or retract said rest and shift its position for the purpose set forth. 4th. In an article of the class described, the combination with a forward and a rear member, of an intermediate member the opposite extremities of which are hinged to diametrically opposite extremities of said forward and said rear member, and means for adjusting the relative inclination of said members, for the purpose set forth. 5th. In an article of the class described, the combination with a back-rest, of a series of folding members secured to said rest, and means for adjusting the relative angles of inclination of said rest and said members, for the purpose set forth.

**No. 57,555. Belt. (Courroie.)**

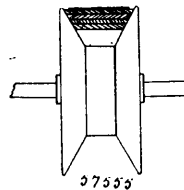
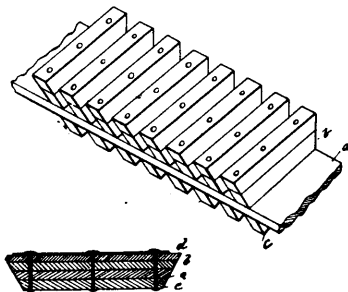

The Reeves Pulley Co., assignee of Milton O. Reeves, both of Columbus, Indiana, U.S.A., 23rd September, 1897; 6 years. (Filed 6th September, 1897.)

*Claim.*—A belt consisting of a continuous strip with a series of lateral strips secured to each side thereof, and having bevelled driving edges, substantially as and for the purpose set forth.

**No. 57,556. Box. (Boîte.)**

Johann Otto Egestorf, Camden Town, London, England, 23rd September, 1897; 6 years. (Filed 15th September, 1897.)

*Claim.*—1st. In a device for containing and discharging soluble or pulverulent material under water, the combination with a box or body to hold said material having an opening or openings at one end thereof and a strainer or porous guard over said opening or openings, of another aperture in the said box or body, and an elastic diaphragm or partition closing said aperture and adapted to serve as means to draw the water into and force the same out again from said box and thereby expel the desired quantity of said material, substantially as and for the purposes hereinbefore described. 2nd.

In a device for holding and discharging soluble or pulverulent material under water, the combination with a metal box or case having

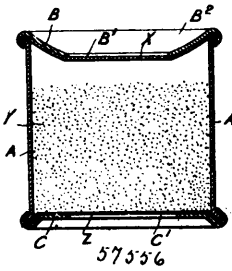

openings in opposite ends thereof, of rubber diaphragm covering and closing the opening in one end of said box, and a strainer or porous diaphragm composed of a textile fabric covering the opening at the opposite end, substantially as and for the purposes described. 3rd. The combination with a box or body such as A, having a discharge opening such as B', at one end thereof with a porous diaphragm such as X, covering said aperture B', of an aperture such as C', and a partition or diaphragm of elastic material such as Z, to close said aperture and adapted to be pressed by the finger or thumb of the user to expel laundry blue or other material when said box is immersed in water, substantially in the manner and for the purposes hereinbefore described. 4th. A box for holding and discharging laundry blue or the like under water, constructed of a sheet metal body such as A, a bottom end C, with an aperture such as C' therein, a flexible diaphragm of sheet rubber or the like elastic material Z, laid in between the said bottom end C, and the body A, and secured by seaming or crimping the two latter together, a top end B, with an aperture such as B' therein, and a diaphragm of porous material such as flannel or other suitable textile fabric X, laid in between said top B and said body A, and secured by seaming or crimping the two latter together, all combined and arranged to act substantially in the manner and for the purposes hereinbefore set forth.

#### No. 57,557. Street Railway Switch.

(Aiguille de chemin de fer.)

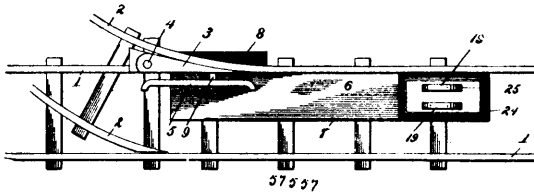

William A. Grant, assignee of Filmore Peters, both of Cornwall, Ontario, Canada, 23rd September, 1897; 6 years. (Filed 2nd September, 1897.)

*Claim.*—1st. In an automatic switch, the combination with an operating lever suitably connected to a switch-tongue, of mechanism arranged adjacent to said operating lever and adapted to actuate the latter when operated by suitable devices carried by a car, substantially as described. 2nd. In an automatic switch, the combination with an operating lever suitably connected to a switch-tongue, of a series of operating cams adjacent thereto, and suitable connections between said cams and the operating lever whereby the latter is shifted by suitable devices carried by a car, substantially as described. 3rd. In an automatic switch, the combination with an operating lever arranged beneath the surface of the track and suitably connected to a switch-tongue, of a series of operating cams arranged adjacent to said lever and provided with bevelled surfaces, a friction-reducing device carried by the operating lever and adapted to be contacted by said cams when the latter are depressed, and means for depressing the cams, substantially as described. 4th. In an automatic switch, the combination with an operating lever arranged beneath the surface of the track and suitably connected to a switch-tongue, of means for shifting said lever, and means for assisting movement of the lever, substantially as described. 5th. In an automatic switch, the combination with an operating lever arranged beneath the surface of the track and suitably connected to a switch-tongue, of a series of operating cams pivoted adjacent to said lever, an antifriction roller carried by the operating lever and adapted to be contacted by said cams, and means for assisting movement of

the lever, substantially as described. 7th. In an automatic switch, the combination with a box, of a covering-plate therefor, an operating lever pivoted to the underside of said plate and working within said box, said lever being suitably connected to a switch-tongue, an antifriction roller carried by said lever, a series of operating cams pivoted adjacent to said antifriction roller and adapted to contact therewith for shifting the operating lever, and means for returning the operating cams to their normal position, substantially as described. 8th. In an automatic switch, the combination with a box, of a covering-plate therefor, an operating lever pivoted to the underside of said covering-plate and working within said box, said lever being suitably connected to a switch-tongue, a series of operating cams pivoted adjacent to said operating lever and provided with bevelled surfaces, an antifriction roller carried by said lever, said bevelled surfaces being adapted to contact with the roller when the operating cams are depressed, and spring springs for returning said cams to their normal position, substantially as described. 9th. In an automatic switch, the combination with a box, of a covering-plate therefor, an operating lever pivoted to the underside of said plate and working within said box, said lever being suitably connected to a switch-tongue, a series of operating cams pivoted adjacent to said lever and provided with bevelled surfaces, an antifriction roller carried by the operating lever, said surfaces being adapted to contact with said antifriction roller for shifting the operating lever, means for returning the operating cams to their normal position and a spring secured to the underside of the covering plate and provided with a projection adapted for assisting movement of the operating lever, substantially as described. 10th. In an automatic switch, the combination with an operating lever suitably connected to a switch-tongue and a series of operating cams for shifting said lever, of a series of swinging arms carried by a car and adapted to contact with said cams, a series of cam-levers for actuating said arms, and suitable connections between said cam-levers and the arms, substantially as described. 11th. An automatic switch comprising a box, a covering-plate therefor, an operating lever pivoted to the underside of said covering-plate and working within said box, said operating lever being suitably connected to a switch-tongue, an antifriction roller carried by the operating lever, a series of operating cams pivoted adjacent to said lever and provided with bevelled surfaces adapted to contact with said antifriction roller for shifting the lever, means for returning the cams to their normal position, and means for assisting movement of the operating lever, in combination with a series of swinging arms carried by a car, a series of cam-levers also carried by the car, and suitable connections between said cam-levers and the swinging arms, and latter being adapted to contact with the operating cams for shifting the switch, substantially as and for the purpose described.

#### No. 57,558. Incandescent Gas Light.

(Bec de gaz incandescent.)

The Welsbach Incandescent Gas Light Company, Montreal, Quebec, Canada, assignee of Dr. Carl Auer Von Welsbach, Vienna, Mether Austria, Austria, 24th September, 1897; 6 years. (Filed 20th June, 1895.)

*Claim.*—1st. A hood or frame for an incandescent gas-burner consisting of substantially pure thorium oxide with a small proportion of the oxide of any one or more of such of the rare metals as when added to the thorium oxide gives to it or excites it to a higher illuminating power or vivid incandescence, substantially as and for the purposes set forth. 2nd. A hood or frame for an incandescent gas-burner composed essentially of thorium oxide and a comparatively small percentage of the oxide of any one of the hereinbefore-mentioned rare metals, substantially as set forth. 3rd. A hood or frame for an incandescent gas-burner, composed essentially of thorium oxide with a comparatively small percentage of the combined oxides of such of the hereinbefore-mentioned rare metals as may be selected, and which possess in their combined or mixed condition the necessary properties that when added to the thorium oxide gives to it or excites it to a high illuminating power or vivid incandescence, substantially as set forth. 4th. A substance capable of resisting excessive heat and of radiating light in a glowing state, consisting of thorium oxide and a small proportion of cerium oxide or its equivalent as an excitant, substantially as described. 5th. A filament fabric or textile frame of combustible material, impregnated with a solution consisting essentially of a salt of thorium with a relatively small proportion of the salt or oxide of one or more of the hereinbefore-mentioned rare metals, substantially as set forth. 6th. A filament fabric or textile substance of combustible material for manufacture into an incandescence substance, impregnated with a solution consisting essentially of a salt of thorium and a small percentage of the salt or oxide of one or more of such of the rare metals as when added to the thorium oxide gives to it or excites it to a high illuminating power or vivid incandescence, dissolved in water, substantially as set forth. 7th. A filament fabric or textile frame or substance of combustible material for manufacture into an incandescent substance, impregnated with a solution consisting essentially of salt of thorium and a relatively small proportion of a salt or oxide of cerium, yttrium and zirconium, dissolved in water with or without the addition of ammonium nitrate, substantially as set forth. 8th. A filament fabric or textile substance of combustible material for manufacture into an incandescent substance, impregnated with a solution con-

sisting of a salt of thorium and a small percentage of the salt or oxid of one or more of such of the rare metals as when added to the thorium oxid gives to it or excites it to a high illuminating power or vivid incandescence, dissolved in water with the addition of ammonium nitrate, substantially as set forth.

No. 57,559. Box Fastener. (Attache de boîtes.)

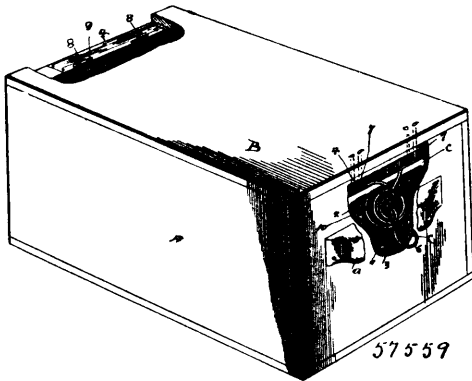

Joseph Ehler, Port Hudson, Missouri, U.S.A., 21th September, 1897; 6 years. (Filed 10th September, 1897.)

Claim.—1st. In a box fastener, a box, a lid therefor, said lid having a series of staples projecting therefrom, a roller carried by the box, studs projecting from the roller, and adapted to be thrown into the staples to secure the lid in position, and means for locking the roller so as to maintain the studs in inoperative position. 2nd. In a box fastener, a lid therefor, said lid having one or more staples projecting therefrom, a spring-operated roller mounted in each end of the box, studs projecting from each roller, and means for locking the roller so as to maintain the studs in inoperative position.

No. 57,560. Car Coupler. (Attelage de chars.)

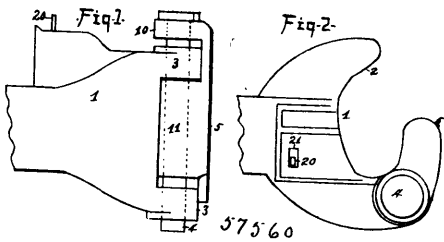

John LaBurt, Jamaica, New York, U.S.A., 24th September, 1897; 6 years. (Filed 9th September, 1897.)

Claim.—1st. A car coupling comprising a coupling head, a swinging knuckle, a ball bearing on the upper side of one of its knuckle pin lugs, to engage in an arc slot in a portion of the knuckle, the said slot gradually increasing in depth from one end to the other, whereby the knuckle may open by gravity, and locking means for the knuckle, substantially as specified. 2nd. A car coupling comprising a head, a swinging knuckle therein, a lock latch pivoted in the head having a chamber communicating with a restricted upper and outward opening, and a downward outward opening at one end, and a lifting bolt having a head portion to move in said chamber, and to engage against the shoulders formed by the restricted opening, substantially as specified. 3rd. The combination with a coupling head, a swinging knuckle, and a lifting bolt, of a locking latch pivoted in the head, and having a longitudinally disposed chamber, provided with a restricted opening through the top of the latch, and opening at one end through the bottom of the latch, substantially as specified.

No. 57,561. Towel Rack. (Porte-serviettes.)

Jennie Louise Cox, Brantford, Ontario, Canada, 24th September, 1897; 6 years. (Filed 9th September, 1897.)

Claim.—1st. The combination of a reversible roller having the corrugation J, on one side, and the square extension or projection H, at one end, with the correspondingly shaped aperture in bracket I, at one end of rack, and the spring clamping bar B, substantially as and for the purpose hereinbefore set forth. 2nd. The combination, with a towel rack, of the spring clamping arms N, N, substan-

tially as and for the purpose hereinbefore set forth. 3rd. The combination, with the bar R, of hinged arms S, S, the springs T, T,

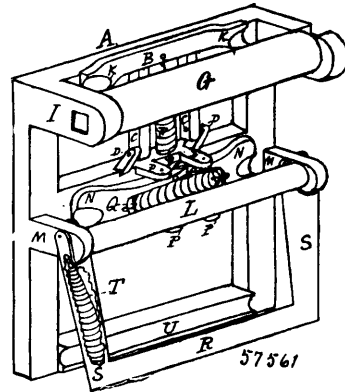

and the groove U, substantially as and for the purpose hereinbefore set forth.

No. 57,562. Packing and Storing Vessel. (Vaisseau à emballer et emmagasiner.)

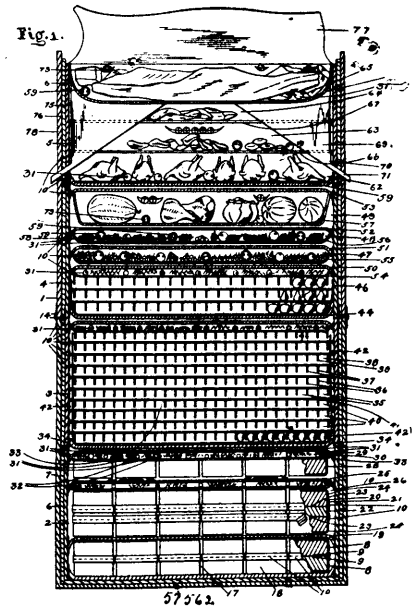

Albert Baker, Fort Wayne, Indiana, U.S.A., 24th September, 1897; 6 years. (Filed 28th July, 1897.)

Claim.—1st. In a storing case in which two separate parts require to be attached and sealed, the one to the other, the combination with said two parts, of a packing band composed of a strip or band of flexible material coated with two or more strips longitudinally of different kinds of adhesive material, each being made adhesive by subjection to different elements respectively. 2nd. In a packing or storing vessel, capsules placed within the case adapted to contain and gradually discharge their contents so as to affect the provisions while they are hermetically sealed, and also adapted in form to be oscillated or rolled by the agitation of the case. 3rd. In a packing or storing vessel, a packing band composed of a flat strip or band of flexible material coated with two or more strips longitudinally of different kinds of adhesive material, each kind made adhesive by subjection to different elements respectively, and a cord for strengthening and stiffening the same, longitudinally placed underneath the coatings. 4th. In a packing and storing vessel in which compartments for different kinds of food are placed, a removable compartment case of waterproof material adapted to fit snugly in said vessel provided with interior receptacles or vessels and suitably sealed, so that one closed the other in series, the whole forming a tier of double vessels in the compartment case, a diaphragm placed over said tier, a second tier of vessels 21 provided with a band separating the open ends from each other and adapted to hold a portion of the provisions, the two vessels and band sealed to each other as described, a diaphragm placed above said second tier secured to the walls of the compartment case as described, a third tier of open or uncovered

vessels 28, a double diaphragm 29 placed above said third tier and secured to the walls of the compartment case, the lower diaphragm being made of porous material. 5th. In a packing and storing vessel, a sub-vessel consisting of two parts adapted to hold provisions, their open ends of similar size and shape, a band placed between the open ends of said two parts adapted to hold a portion of the provisions, and packing bands adapted to secure and hermetically seal them all in position. 6th. In a packing and storing vessel in which compartments for different kinds of food are placed, a removable compartment case adapted to fit in said vessel provided with partitions subdividing the case into tiers of square cells, the partitions being made of waterproof material practically odorless and flavorless, and so constructed as to permit a slight movement and have some elasticity, a diaphragm placed between the tiers, means to lift the tiers or fillers out separately, or one or more together, and two diaphragms placed above all the tiers, the lower one adapted to permit substances placed between them to be diffused through it gradually into the cells below. 7th. In a packing and storing vessel in which compartments for different kinds of food are placed, a removable compartment case adapted to fit in said vessel and provided with diaphragms adapted to separate the provisions from each other, and to be secured hermetically to the walls of the compartment, and capsules placed between them. 8th. In a packing or storing vessel in which compartments for different kinds of foods are placed, a movable case divided by a diaphragm into sub-compartments, the diaphragm being arranged to form a sack which is provided with flaps for drainage through a tube leading through the outside of the case. 9th. In a packing and storing vessel, double capsules consisting of one capsule placed within another and preserving material placed between them and held in place by the other capsule. 10th. In a packing and storing vessel, a compartment case adapted to hold brine and other fluid solutions, provided with tiers of square cells for eggs, filling the case, the partitions of which are made of water and brine proof material practically odorless and flavorless and of sufficient gravity to sink in the brine and hold down the diaphragm or partition plates placed between the tiers. 11th. In a packing and storing vessel, a partition plate in combination with a packing band composed of a flat strip or band of flexible material coated on both sides with three or more stripes, longitudinally, of different kinds of adhesive material, each made adhesive by subject to different elements respectively, and a cord placed between the coating and the partition plate to rest upon and be attached to.

adapted to receive and hold the body of the fastener, and also with a clinching post, the other of said jaws adapted to engage and bend the ends of the fastener and clinch the same against said clinching post, as and for the purpose set forth. 2nd. In a hand tool for inserting and setting lace fasteners, a pair of co-operating jaws one of said jaws provided with one or more seats for receiving the fastener, a post formed centrally in said seat, and the other of said jaws arranged to engage and bend the ends of the fastener and to clinch the same upon said post, as and for the purpose set forth. 3rd. In a hand tool for inserting and setting lace fasteners, a pair of co-operating jaws, one of said jaws provided with one or more seats adapted to receive the body of the fastener, having a post arranged centrally in said seat or seats, means for retaining the fastener in said seat or seats, the other of said jaws arranged to engage and bend the ends of the fastener and to clinch the same upon said post, as and for the purpose set forth. 4th. In a hand tool for inserting and setting lace fasteners, a pair of co-operating jaws, one of said jaws formed with one or more seats adapted to receive and hold the fastener and having a clinching post therein, the other of said jaws provided with a pair of depressions corresponding to each of said seats, said depressions being angularly arranged with respect to each other and having curved bottoms adapted to engage and bend the ends of the fastener and to clinch the same upon said post, as and for the purpose set forth.

**No. 57,565. Inserting Machine for Lace Fasteners.**  
(Machine à insérer.)

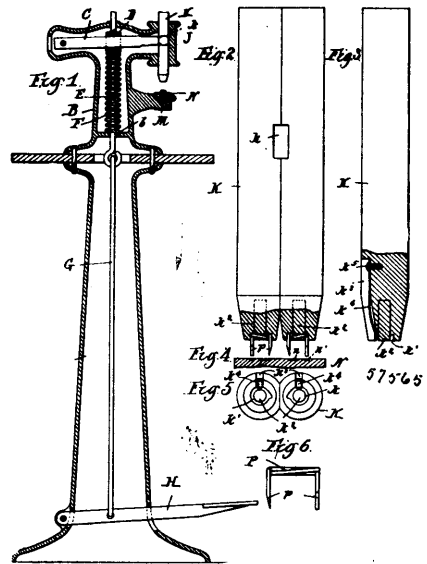

Rodolph Wirth, Chicago, Illinois, U.S.A., 24th September, 1897; 6 years. (Filed 3rd May, 1897.)

*Claim.*—1st. In a machine for inserting and setting lace fasteners, a plunger provided with a seat in the end thereof, and adapted to receive a fastener therein, means for retaining the fastener in said seat, a clinching post arranged in said seat, an anvil arranged in the line of movement of said plunger and adapted to be engaged by, and to bend the ends of the fastener upon the underside of the article to which the fastener is to be applied, whereby the parts of said fastener are clinched upon the clinching post, and means for reciprocating said plunger, as and for the purpose set forth. 2nd. In a machine for inserting and setting lace fasteners, a plunger provided with a seat in the end thereof, adapted to receive a fastener therein, said plunger being cut away adjacent to said seat, a spring mounted in said cut-away part, and having its end arranged to project into said seat, whereby a fastener placed in said seat is held therein, an anvil arranged in the line of movement of said plunger, arranged to bend the ends of the fastener, and means for reciprocating said plunger, as and for the purpose set forth. 3rd. In a machine for inserting and setting lace fasteners, a plunger provided with a seat in the end thereof, adapted to receive a fastener therein, and having a clinching post arranged in said seat, said plunger being cut away adjacent to said seat, a spring mounted in said cut away part, and having its ends arranged to project into said seat to hold the fastener therein, an anvil arranged in line of movement of said plunger and provided with concave depressions, arranged relatively to each other to engage and bend the ends of the fastener into angular relation with respect to each other, as and for the purpose set forth. 4th. In a machine for inserting and setting lace fasteners, a plunger provided with a seat in the end thereof, adapted to receive a fastener therein, a clinching post inserted in the end of said plunger, and having its

**No. 57,563. Game Board.** (Planche de jeu.)

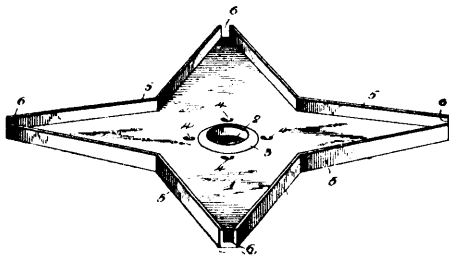

57563

David Franklin Heverly, Center Point, Iowa, U.S.A., 24th September, 1897; 6 years. (Filed 22nd May, 1897.)

*Claim.*—A game board comprising a four-pointed star in outline, surrounded by a continuous rail, open only at the apex of the star-points, and provided with a central pocket surrounded by an inclined wall, and a series of recesses, arranged equidistant and concentric with said pocket, substantially as herein shown and described.

**No. 57,564. Hand Tool for Inserting and Setting Lace Fasteners.** (Outil pour insérer et poser les attaches de lacets.)

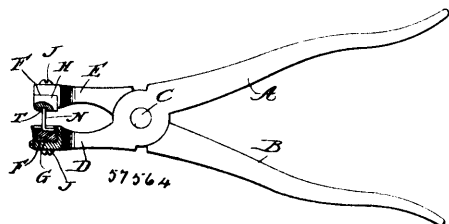

Rodolph Wirth and Frank M. Fargo, both of Chicago, Illinois, U.S.A., 24th September, 1897; 6 years. (Filed 3rd May, 1897.)

*Claim.*—1st. In a hand tool for inserting and setting lace fasteners a pair of co-operating jaws, one of said jaws provided with a seat

end arranged to project into said seat, means for retaining a fastener in said seat, a removable anvil arranged in the line of movement of said plunger, and provided with angularly arranged concaved depressions, and means for reciprocating the plunger, as and for the purpose set forth. 5th. In a machine for inserting and setting lace fasteners, a plunger provided with a pair of seats in the end thereof, said seats being respectively arranged to receive a right and left fastener, means for retaining a fastener in each seat, an anvil arranged in the line of movement of said plunger, and provided with a pair of concaved depressions arranged to co-operate with each seat in said plunger to bend the ends of the fastener, and means for reciprocating said plunger, as and for the purpose set forth.

**No. 57,566. Ice and Snow Locomotive.**  
(Locomotive pour la glace et neige.)

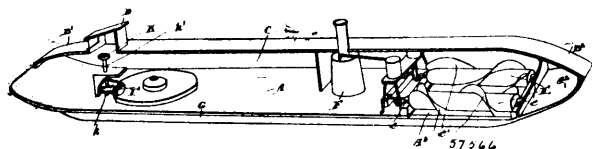

William Henry Harvey, Toronto, Ontario, Canada, 24th September, 1897; 6 years. (Filed 10th September, 1897.)

*Claim.*—1st. An ice and snow locomotive comprising a flat bottom with upturned ends, and a propelling wheel or wheels provided with convolute flanges suitably journaled on the bottom of the locomotive and designed when driven to have a running grip upon the snow or ice, as and for the purpose specified. 2nd. An ice and snow locomotive comprising a flat bottom with upturned ends and provided with an opening in the same, and a propelling wheel or wheels provided with convolute flanges extending through such opening and designed when driven to have a running grip upon the snow or ice, as and for the purpose specified. 3rd. An ice and snow locomotive comprising a flat bottom with upturned ends and provided with an opening in the same, a propelling wheel or wheels provided with convolute flanges extending through such opening and designed when driven to have a running grip upon the snow or ice and longitudinal runners extending throughout the length of the locomotive and to each side of the propelling wheels, as and for the purpose specified. 4th. An ice and snow locomotive comprising a flat bottom with upturned ends and provided with an opening in the same, a propelling wheel or wheels provided with convolute flange extending through such opening and designed when driven to have a running grip upon the snow or ice, longitudinal runners extending throughout the length of the locomotive and to each side of the propelling wheels and supplemental gripping runners situated in the main runners directly to each side of the propelling wheels, as and for the purpose specified. 5th. An ice and snow locomotive comprising a flat bottom with upturned ends and provided with an opening in the same, a propelling wheel or wheels provided with convolute flanges extending through such opening and designed when driven to have a running grip upon the snow or ice, longitudinal runners extending throughout the length of the locomotive and to each side of the propelling wheels and a supplemental front central steering runner, and means for manipulating the same, as and for the purpose specified. 6th. An ice and snow locomotive comprising a flat bottom with upturned ends and provided with an opening in the same, a propelling wheel provided with convolute flanges extending through such opening and designed when driven to have a running grip upon the snow or ice, longitudinal runners extending throughout the length of the locomotive and to each side of the propelling wheels, a supplemental central steering runner, a toothed rack on the turning plate of the runner and an engaging pinion rod and hand-wheel, all arranged as and for the purpose specified.

**No. 57,567. Sanding Apparatus for Railway Cars.**  
(Appareil à sabler pour chars de rues.)

William Thomas Hamilton, Allegheny City, Pennsylvania, U.S.A., 24th September, 1897; 6 years. (Filed 13th September, 1897.)

*Claim.*—1st. In apparatus for sanding railway tracks, the combination of a sand-discharge apparatus, a cylinder for operating the same, valve mechanism controlling the air-brakes of the car, and, in addition to the service-stop mechanism, provided with an emergency valve for applying a more powerful emergency stop, and a port for supplying air to the sand-discharge cylinder, said port being opened only by motion of the emergency valve, substantially as described. 2nd. In apparatus for sanding railway tracks, the combination of a sand-discharge apparatus, a cylinder for operating the same, air-brake valve mechanism comprising an emergency valve which moves on the occasion of an emergency stop, a valve which admits air to the sand-discharge cylinder and is opened by motion of the emergency valve, and a second oppositely-acting discharge-valve from the sand-discharge cylinder, which valve opens into the chamber 18 of the air-brake valve, substantially as described. 3rd. In apparatus for sanding railway tracks, the combi-

nation of a sand-discharge apparatus, a cylinder for operating the same, air-brake valve mechanism, comprising an emergency-valve

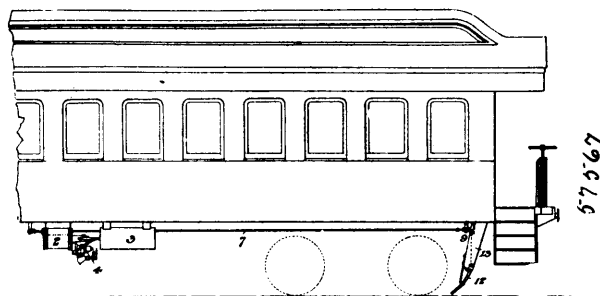

which moves on the occasion of an emergency stop, a port which connects the auxiliary air-reservoir with the sand-discharge cylinder, and means for opening said port on motion of the emergency-valve, substantially as described. 4th. In apparatus for sanding railway tracks, the combination of a sand-discharge apparatus, a cylinder for operating the same, valve mechanism which controls the air-brakes of the car and is adapted to apply thereto a service stop and more powerful emergency stop, a port connecting the sand-discharge cylinder with the air-brake valve, and a slide on the emergency-valve which controls said port, substantially as described. 5th. In apparatus for sanding railway tracks, the combination of a sand-discharge apparatus, a motor for operating the same, an air-brake valve mechanism containing an emergency-valve, and means controlled by the emergency-valve for actuating said motor, substantially as described. 6th. In apparatus for sanding railway-tracks, the combination of a sand-discharge apparatus, a cylinder for operating the same, valve mechanism which controls the air-brakes of the car and is adapted to apply thereto a service stop and more powerful emergency stop, a port connecting the sand-discharge cylinder with the air-brake valve, and a slide on the emergency-valve which controls said port, and a check-valve in said port, substantially as described. 7th. In apparatus for sanding railway-tracks, the combination of a sand-discharge apparatus, air-brake valve mechanism, comprising an emergency-valve, an auxiliary air reservoir, and a port which connects with the air reservoir and is opened by motion of the emergency-valve to permit the passage of air to operate the sand-discharge mechanism, substantially as described.

**No. 57,568. Leg for Billiard, Pool and Other Tables,**  
(Pieds de tables de billiards, etc.)

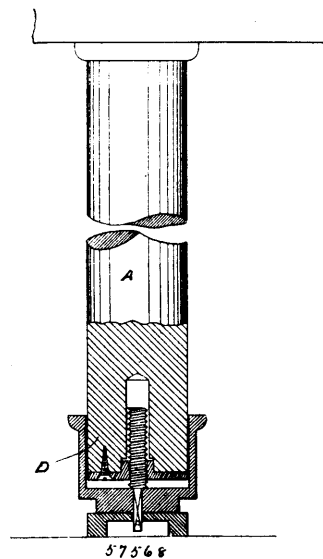

Amedée Francois Lamoureux, Montreal, Quebec, Canada, 24th September, 1897; 6 years. (Filed 13th September, 1897.)

*Claim.*—In legs for billiard, pool and other tables, a device to lengthen or shorten them and consisting in a nut B, stud C, with its cup-shaped head D, and floor plate E freely turning on the portion c<sup>2</sup> of stud C, substantially as described and for the purposes set forth.



**No. 57,569. Awning.** (*Appareil pour auvents.*)

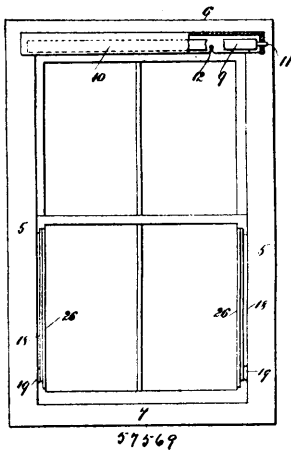

William Johnson, Mott, California, U.S.A., 24th September, 1897 ; 6 years. (Filed 13th September, 1897.)

*Claim.*—1st. An awning attachment for windows, consisting of a shield or casing which is adapted to be secured to the frame of the window at the top thereof, said shield or casing being open at its lower side, and being provided with a spring roller which is mounted therein, an awning connected with said spring roller, and devices connected with the lower end of said awning for holding the same in position when in use, substantially as shown and described. 2nd. An awning attachment for windows, consisting of a shield or casing which is adapted to be secured to the frame of the window at the top thereof, said shield or casing being open at its lower side, and being provided with a spring roller which is mounted therein, an awning connected with said spring roller, and devices connected with the lower end of said awning for holding the same in position when in use, said devices consisting of spring operated arms which are connected with the lower end of the awning, and with the sides of the window frame, and brace rods connected with the outer ends of said arms and adapted to be connected with pins or projections secured to the side of the window frame, substantially as shown and described. 3rd. In an awning attachment for windows consisting of a shield or casing which is adapted to be secured to the frame of the window at the top thereof, said shield or casing being open at its lower side, and being provided with a spring roller which is mounted therein, an awning connected with said spring roller, and devices connected with the lower end of said awning for holding the same in position when in use, said devices consisting of spring operated arms which are connected with the lower end of the awning, and with the sides of the window frame, and brace rods connected with the outer ends of said arms and adapted to be connected with pins or projections secured to the side of said window frame, said awning being also provided with side pieces which are adapted to be detachably connected with the sides of the window frame, substantially as shown and described.

**No. 57,570. Hub Attaching Device.** (*Appareil d'attache de moyeu.*)

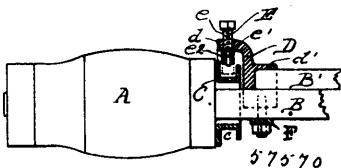

Frederick Anthony Manegold, Reading, Pennsylvania, U.S.A., 24th September, 1897 ; 6 years. (Filed 15th September, 1897.)

*Claim.*—The combination with an axle and wheel hub, of a separately formed grooved ring fixed to the inner face of the hub and rotating therewith, an axle attachment having a projection thereon overhanging said grooved ring and a pin or screw in said overhanging projection having a sleeve or roller *e* fixed to the inner end thereof and adapted to loosely enter the groove in the ring, said pin or screw being capable of a limited inward and outward movement in the overhanging projection sufficient to allow the sleeved end to be thrown into or out of engagement with the grooved ring, substantially as and for the purpose set forth.

**No. 57,571. Car Coupler.** (*Attelage de char.*)

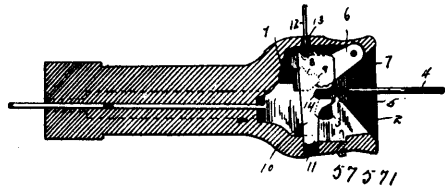

Joseph Callantine, Peru, Indiana, U.S.A., 24th September, 1897 ; 6 years. (Filed 15th September, 1897.)

*Claim.*—1st. In a car-coupling, the combination of a draw-head, a fixed catch arranged at the bottom thereof, and provided with a link receiving recess, a pivoted catch depending from the top of the draw-head and arranged to engage a fixed catch to confine the link in the recess thereof, and a substantially U-shaped linkholder straddling the catches and provided with link receiving recesses, and adapted to engage the upper and lower faces of a link, substantially as and for the purpose set forth. 2nd. In a car-coupling, the combination of a draw-head, a pivoted catch located at the bottom thereof, and provided with a link receiving recess and having a lug or projection, a substantially U-shaped linkholder straddling the catches, resting upon and supported by the pivoted catch and provided at its sides with recesses located adjacent to the link receiving recess, and a rod connected with the pivoted catch and passing through the linkholder at the top of the draw-head, substantially as and for the purpose described.

**No. 57,572. Railroad Frog.** (*Rail de croisement.*)

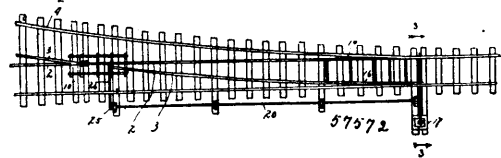

Robert Selthun, Fort Bayard, New Mexico, U.S.A., 24th September, 1897 ; 6 years. (Filed 15th September, 1897.)

*Claim.*—1st. The combination with the main and branch rails secured to the usual ties, of a series of cross and longitudinal bars constituting a frame also secured to said ties, and a frog pivoted to one of said cross-bars, substantially as and for the purpose described. 2nd. The combination with the main and branch track-rails secured to the usual ties, of a series of cross and longitudinal bars suitably connected one to the other, constituting a frame also secured to said ties, a frog-rail resting upon two adjacent cross-bars and pivoted to one of them, stops secured to the sides of the main and branch track-rails for limiting the outward movement of said frog-rail, and means for shifting said frog, substantially as and for the purpose described. 3rd. The combination with the main and branch track rails secured to the usual ties, of a series of cross and longitudinal bars suitably connected one to the other, constituting a frame also secured to said ties, a frog-rail also resting upon said frame having a pivotal bolt or pin, secured to or formed integral with one end thereof and fitting in one of said cross-bars, stop pieces secured to the open ends of said main and branch track-rails for limiting the outward movement of said frog-rail, and a guide-rod or bar connecting the ends of said stop-pieces and passing through the slot or opening in said frog-rail, substantially as and for the purpose described. 4th. The combination with the main and branch track-rails secured to the usual ties, of a frame made up of a pair of parallel side rails secured to the upper sides of said ties, and a series of cross-bars secured to the underside of said side rails whose upper surface lie flush with the adjacent ties, a frog having a pin or bolt on the underside thereof fitting within a corresponding opening in one of said cross-bars adjacent to the V formed by the juncture of the inner main and branch rails, guide-pieces having bevelled inner edges secured to said cross-bar adjacent to the pivotal point of said frog, stop-pieces for the outer end of said frog, and a guide rod or bar connecting said stop-pieces and projecting through an opening in said frog, substantially as and for the purpose described.

**No. 57,573. Bicycle Handle.** (*Poignée de bicycless.*)

John G. Hodgson, Illinois, U.S.A., 25th September, 1897 ; 6 years. (Filed 7th April, 1897.)

*Claim.*—1st. A handle for a bicycle handle having a stiff or rigid lower portion or segment extending to the outer end of the handle, and a yielding or elastic upper portion or segment, said yielding or elastic portion or segment being only at the outer portion of the handle, substantially as specified. 2nd. A bicycle handle comprising, in combination a metal shell B, a filling of hard material C, extending around the handle at the inner half or portion thereof, and

an elastic or yielding part D at the upper and outer portion of the handle, such metal shell B being enlarged at the lower and outer

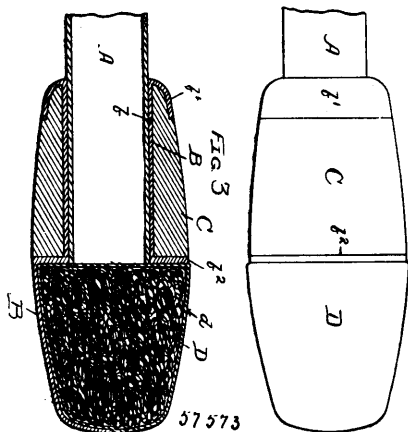

part of the handle to form a socket or receptacle to receive the yielding or elastic outer upper portion of the handle, substantially as specified.

**No. 57,574. Water-heating Boiler.**

(*Chaudière à eau chaude.*)

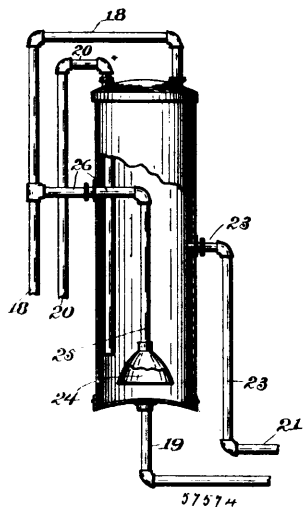

John P. B. Sadler, Baltimore, Maryland, U.S.A., 25th September, 1897; 6 years. (Filed 7th September, 1897.)

*Claim.*—1st. The combination, with a boiler having the usual induction and discharge hot water pipes, and a cold water induction pipe, of a supplemental hot water discharge pipe from the boiler, and connected to the said usual hot water discharge pipe upon the outside of the boiler, as set forth. 2nd. The combination, with a boiler having the usual water circulating pipes, of a supplemental hot water discharge pipe extending from the inside of the boiler, and connected to the usual hot water discharge pipe upon the outside of the boiler, as set forth. 3rd. The combination, with a boiler having the usual water circulating pipes, of a supplemental hot water discharge pipe extending from the inside of the boiler, and connected to the usual hot water discharge pipe upon the outside of the boiler, as set forth. 4th. The combination, with a boiler having the usual water circulating pipes, of a supplemental discharge pipe extending from the boiler, and connected to the said usual hot water discharge pipe upon the outside of the boiler, and a hood opening into the boiler and connected to the said supplemental pipe, as set forth. 5th. The combination, with a boiler having the usual water circulating pipes, of a supplemental discharge pipe extending from the boiler, and connected to the said usual hot water discharge pipe upon the outside of the boiler, and a hood opening into the boiler and connected to the said supplemental pipe, as set forth. 6th. The combination, with a boiler having the usual hot and cold water pipes, of a supplemental discharge pipe connected to the hot water discharge pipe and extending into the boiler, of an open hood in the boiler, and a vertical pipe connecting the hood with the said supplemental pipe, as set forth.

**No. 57,575. Oil Can. (*Bidon à huile.*)**

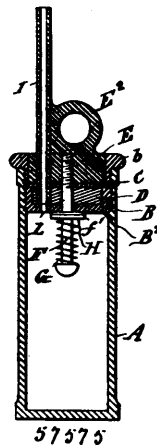

Monroe Le Vino, New York, State of New York, U.S.A., 25th September, 1897; 6 years. (Filed 15th September, 1897.)

*Claim.*—1st. An oil can, having a closing disc, a cut-off disc, and a packing washer between the discs, all located in the mouth of the can, and having registrable eccentrically located in exit orifices, an exterior handle connected to the cut-off disc to rotate it, and projections from the cut-off disc entering the packing washer to bind and rotate the two together, substantially as described. 2nd. An oil can, having a closing disc, a cut-off disc, and a packing washer, all located in the mouth of the can and having registrable eccentric oil exit orifices and central apertures, a bolt passing through the central apertures and binding the parts together, a spring upon the inner end of the bolt, an exterior handle connected to the cut-off disc to rotate it, and projections from the cut-off disc entering the packing washer to rotate the two together, substantially as described. 3rd. An oil can, having a closing disc, a cut-off disc, and a packing washer between the discs, all being located in the mouth of the can and having eccentrically located registrable apertures and a central aperture, an oil spout extending through the eccentric apertures in the cut-off disc and the packing washer, and locking the two to rotate together, substantially as described. 4th. An oil can, having a closing disc, a cut-off disc, and a packing washer between the discs, all being located in the mouth of the can and having eccentrically located registrable apertures and a central aperture, an oil spout extending through the eccentric apertures in the cut-off disc and the packing washer and locking the two to rotate together, a threaded bolt passing through the central apertures and screwing into one of the discs, and a spring surrounding said bolt and pressing the discs together, substantially as described. 5th. An oil can, having a closing disc, a cut-off disc and a packing washer between the discs, all located in the mouth of the can and having registrable eccentrically located apertures in the cut-off disc and the packing washer, and forming a handle by which the cut-off disc and packing washer may be revolved from the exterior of the can, substantially as described. 6th. An oil can, having a closing disc, a cut-off disc, a packing washer between the discs, all located in the mouth of the can and having registrable eccentrically located apertures, a spout extending through the eccentric apertures into the cut-off disc and the packing washer, and forming a handle by which the cut-off disc and packing washer may be revolved from the exterior of the can, and a spring acting to hold said disks together, substantially as described. 7th. An oil can, having a circular recess in its head which is stepped or of two diameters, the larger diameter being the outer one, an eccentrically located aperture through the head at the bottom of said recess, a plug fitting said recess, and composed of two parts of different diameter fitting the two sections of the recess, a packing washer between these two parts and seating upon the ledge or stop in the recess, said plug having an eccentrically located aperture extending through both sections and the intermediate washer, and adapted to register with the aperture through the can head, and means for holding the plug within said recess, substantially as described. 8th. An oil can, having a circular recess in its head which is stepped or of two diameters, the larger diameter being the outer one, an eccentrically located and a centrally located aperture through the head at the bottom of said recess, a plug fitting said recess and composed of two parts of different diameters fitting the two sections of the recess, a packing washer between these two parts and seating upon the ledge or stop in the recess, said plug having an eccentrically located aperture passing through both sections and the intermediate washer, and adapted to register with the aperture through the can head, a central aperture extending into the outer section, and a bolt extending from within the can into said outer section and into which it is threaded, substantially as described. 9th. An oil can, having a circular recess in its head which is stepped or of two diameters,

with the larger diameter outward, an eccentrically located and a centrally located aperture through the head at the bottom of said recess, a plug fitting said recess and composed of two parts of different diameters fitting the two sections of the recess, a packing washer between these two parts and seating upon the edge of steps in the recess, said plug having an eccentrically located aperture passing through both sections and the intermediate washer, and adapted to register with the aperture through the can head and a central aperture extending into the other section, a bolt extending from within the can into said outer section and into which it is threaded, a spring surrounding the inner end of said bolt, and a packing washer between the spring and the inner surface of the head, substantially as described. 10th. An oil can, having a closing disk, a cut-off disk and a packing washer, all located in the mouth of the can, eccentric apertures through the disks and washes, and which may be brought into registry, and the spout extending through the apertures in the two outer members and rotatable therein substantially as described. 11th. An oil can, having a closing disk and a cut-off disk, and a packing washer located between said disks all being located in the mouth of the can and each having an eccentrically located aperture which apertures may be brought into register, a spout passing through the two outer members and rotatable therein and having a section of elongated or non-circular section, and a projection on one of the disks adapted to engage said section and band the spout in certain positions, substantially as described. 12th. An oil can having a closing and a cut-off disk located in the mouth of the can and each having registrable eccentric apertures, means for rotating one of the said disks, and a spout passing through the hole in the outer disk and rotatable therein, substantially as described. 13th. An oil can having a closing and a cut-off disk located in the mouth of the can and each having registrable eccentric holes, a spout passing through said hole in the outer disk and rotatable therein and having a non-circular section, and a projection mounted upon the outer disk and adapted to bind on the longer radius of said non-circular section, substantially as described. 14th. In an oil can the combination of a closing disk having an eccentric aperture, a cut-off disk having an eccentric aperture adapted to register with that in the closing disk and a discharge spout mounted eccentrically on the cut-off disk in connection with the aperture therein, substantially as described. 15th. In an oil can the combination of a closing disk having an eccentric aperture, a cut-off disk having an eccentric aperture adapted to register with that in the closing disk and a discharge spout mounted eccentrically on the cut-off disk in connection with the aperture therein and a handle for turning said cut-off disk, substantially as described.

**No. 57,576. Machine for Making Hoops, Handles.**

(Machine à faire les cercles, etc.)

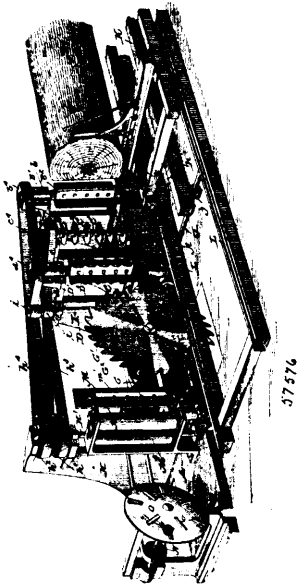

James Fowley, Cobden, Illinois, U.S.A., 25th September, 1897; 6 years. (Filed 10th December, 1896.)

*Claim.*—1st. The combination with the main frame or base, and the saw-table, of the gang of horizontal kerfing-saws arranged about a vertical axis, a shaping-cutter-head arranged in rear of the kerfing-saws about a separate vertical axis, and means for adjusting said kerfing-saws and shaping-cutter heads at right angles to their axis independently of each other to vary the thickness of hoops, and a vertical rip-saw arranged in rear of the shaping-cutter head to sever the strips at the base of the kerfs, substantially as set forth. 2nd.

The combination with the main frame or base, and the saw-table, of the vertical lap-cutter-head arranged at the front end of the main frame and upon one side of the log to act upon the log before the strips are severed, mechanism for feeding said lap-cutter head in or out, the gang of horizontal kerfing-saws in rear thereof, the shaping-cutter head in rear of the kerfing-saws, and the vertical main or rip saw in rear of the shaping-cutter-head, substantially as and for the purpose described. 3rd. The combination with the main frame or base, and the saw table, of the vertical lap cutter-head arranged at the front end of the main frame and upon one side of the log to act upon the log before the strips are severed, means for feeding said lap-cutter-head in and out, the gang of combined horizontal kerfing-saws and planers, in rear of the lap-cutter-head, the vertical shaping-cutter-head in rear of the kerfing-saws to shape the material between the kerfs, and the main combined rip-saw and planer arranged in a vertical plane behind the shaping-cutter-head to sever the strips from the log, substantially as and for the purpose described. 4th. The combination with the main frame or base and the saw-table of the three vertical standards, the inner two of which are connected for simultaneous adjustment toward the saw-table, and the outer one of which has an independent feed mechanism, a vertical lap planer or cutter-head carried by the last-named standard, a gang of horizontal circular kerfing-saws mounted on the middle standard, a shaping-cutter-head mounted on the inner standard, and a vertical rip-saw to sever the strips from the log after it passes the shaping-cutters, substantially as set forth. 5th. The combination with the main frame or base and the saw-table having an operating mechanism, of the outer standard having a feed mechanism geared to the saw-table, a lap-cutter mounted on said standard, a middle standard, the kerfing-saws mounted thereon, the inner standard, the shaping-cutter-head mounted thereon, a horizontal bar positively connecting the middle and inner standard and having a pin and slot connection with said outer standard, a feed screw for feeding the inner standards in and out, and the main or rip-saw for severing the strips after they have passed the shaping-cutter-head, substantially as set forth. 6th. The combination with the base or frame and the saw-table having an operating mechanism, of the vertical standard carrying a cutter-head, a transverse feed shaft operatively connected with the lower end of said standard and having a pinion on its outer end and a short rack on the saw-table to mesh with said pinion, substantially as set forth. 7th. The combination with the base or frame and the saw-table having a short rack and an operating mechanism, of the vertical standard carrying a cutter-head and provided with a groove in its underside, and a transverse feed shaft having a cam-wheel entering said groove and a pinion engaging said short rack, substantially as set forth. 8th. The combination with the base or main frame and the saw-table, of two transversely sliding connected standards mounted on the base or frame, a feed screw mounted in the frame and having a swivelled connection at its inner end with the lower ends of said standards, a gang of kerfing-saws mounted on one standard and a shaping-cutter-head mounted on the other standard to shape the material between the kerfs, substantially as set forth. 9th. The combination with the base and the saw-table, of the gang of kerfing-saws, arranged about a vertical axis, the vertical rip-saw in rear thereof to sever the material into strips at the bases of the kerfs, a vertical guide arranged beyond and next to the rip-saw and having a vertical series of guideways aligning the several strips, substantially as set forth. 10th. The combination with the base and the saw-table, of the vertical lap-cutter-head, the gang of kerfing-saws in rear thereof arranged upon a vertical axis, the shaping-cutter-head in rear of the said saws also arranged about a vertical axis, the rip-saw in rear of the shaping cutters, and the vertical guide beyond and next to the rip-saw and having a vertical series of guideways aligning the spaces between the kerfing saws, substantially as set forth. 11th. The vertical strip guide provided with a series of transverse guideways for the strips, and springs forming the bottoms of the guideways, combined with and arranged next to the vertical rip-saw, substantially as set forth. 12th. The vertical strip guide provided with a series of transverse guideways having springs combined with and arranged next to the vertical rip-saw, and guide rolls adjacent to the guideways, substantially as set forth. 13th. The herein described machine comprising the base or bed, the saw-tables having an operating shaft and gearing, a short rack at the rear end of the saw-table, a standard at the rear end of the frame and provided with a feed shaft geared to said short rack, a lap-cutter-head journalled in said standard, a middle and inner standard adjustably mounted on the base and carrying a gang of kerfing-saws and a shaping-cutter respectively, a drive-shaft geared to the table operating shaft, and carrying a rip-saw at its outer end, to sever the shaped strips at the base of the kerfs, a vertical transmitting shaft having two pulleys, belted to the pulleys of the shafts of said cutter-heads and gang-saw respectively and also belted to the drive-shaft, a guide beyond the rip-saw and a pointer-cutter-head behind the guide and belted to the drive-shaft, substantially as set forth. 14th. The combination with base and end and intermediate adjustable standards, of the horizontal brace connected to the upper end of one of the intermediate standards and slidingly engaging at its ends the two end standards, substantially as set forth. 15th. The combination with the base, and the saw-table and its operating mechanism, of the three adjustable standards having vertical shafts carrying the lap, kerfing and shaping tools, pulleys on the upper ends of the shafts, a drive-shaft, a

vertical transmitting-shaft having two pulleys belted to said first-named pulleys as described, and idler pulleys engaging the outer runs of the belts to tighten them when the standards are adjusted outwardly, substantially as set forth.

**No. 57,577. Animal Trap. (Piège.)**

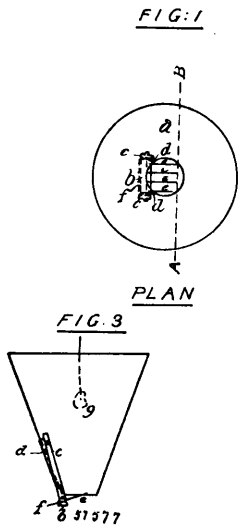

James A. Henry, Stockton, Manitoba, Canada, 25th September, 1897; 6 years. (Filed 1st June, 1897.)

*Claim.*—A trap for the capture of small animals, comprised of a funnel-shaped piece of tin, granite ware or other material, smooth on the inside, with a self-setting adjustable trip, substantially as and for the purpose set forth.

**No. 57,578. Log Peeling Machine. (Machine à décortiquer les billots.)**

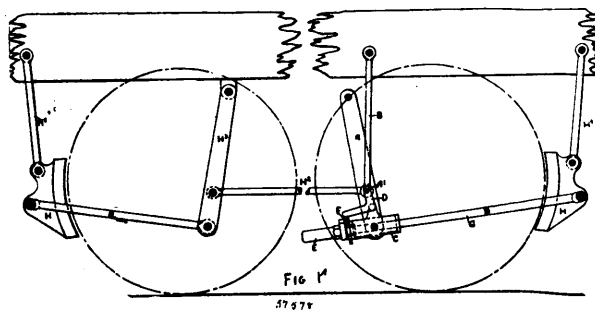

John Moravec, Chatham, New Brunswick, Canada, 25th September, 1897; 6 years. (Filed 28th June, 1897.)

*Claim.*—1st. In a log-peeling machine, the combination, with a bed, a head-stock and a tail-stock mounted on said bed, and a chuck, of a hollow live-spindle carried by the head-stock and arranged to operate the chuck, a plurality of centre-points carried by the tail-stock, a slide-rest, a tool pivotally mounted on the slide-rest and means for keeping the tool at a uniform distance from the periphery of the log. 2nd. In a log-peeling machine, the combination, with a bed, a head-stock and a tail-stock mounted on said bed, and a chuck, of a hollow live-spindle, carried by the head-stock and arranged to operate the chuck, a compound centre device carried by and revoluble on the dead-spindle, a slide-rest, a tool pivotally mounted on the slide-rest, means for keeping the tool at a uniform distance from the periphery of the log, and means for feeding the tool longitudinally. 3rd. In a log-peeling machine, the combination, with means for holding and revolving the log, of a tool-holding device, a tool mounted therein, and means secured to the holding device and resting on the log, whereby the tool is held at a predetermined distance from the periphery of the log. 4th. In a log-peeling machine, the combination, with means for holding and revolving the log, of a tool-holder, a pair of knives placed in said tool-holder, one knife being arranged to cut at right angles to the other, and means for holding the knives in a predetermined relation to the periphery of the log, whereby one knife rips the periphery of the log and the other knife cuts a strip from said log. 5th. In a log-peeling machine, the combination, with a bed having channelled extensions, of a slide-rest provided with brackets, and a series of balls running in the channelled extensions and supporting the

brackets, substantially as described. 6th. In a log-peeling machine, the combination, with a bed, a pair of uprights resting on the bed, a series of balls in said uprights, and a hollow cylinder forming a live-spindle mounted in said uprights and rotatable on the balls.

**No. 57,579. Railway and Car. (Chemin de fer et chars.)**

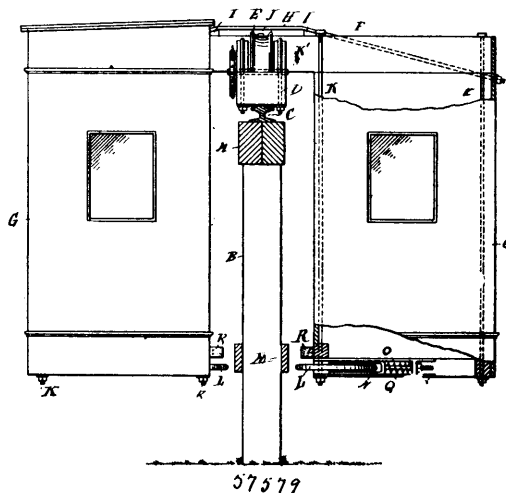

James Hopkirk, Oakland, California, U.S.A., 25th September 1897; 6 years. (Filed 9th September, 1897.)

*Claim.*—1st. The combination with a single line of rail and a continuous longitudinal support thereof, of trucks having journalled wheels adapted to travel upon the rails, transverse bars swivelled upon the trucks and cars suspended from the outer ends of the transverse timbers substantially as described. 2nd. The combination with a single line of track and a frame-work whereby it is supported in line above the surface of the ground, of cars arranged in pairs upon each side of the track and frame-work, trucks having wheels journalled at opposite ends adapted to travel upon the track, a transverse frame-work of timbers centrally swivelled upon the trucks extending across the upper part of each end of the cars whereby the latter are suspended therefrom, and truss braces fixed with relation to the timbers and supported upon saddles centrally disposed upon the transverse timbers as described. 3rd. The combination with a single line of track and a frame-work upon which it is supported longitudinally above the surface of the ground, of cars mounted in pairs upon opposite sides of the track and frame-work, trucks having wheels journalled at opposite ends adapted to travel upon the rails, transverse timbers centrally swivelled upon the trucks extending through the opposite ends and upper part of each car, hangers support-d from the transverse timbers extending downwardly upon the outer and inner sides of the cars respectively, and nuts and washer plates by which the weight of the cars is adjustably supported from said hangers. 4th. The combination with a single line of rails, a continuous frame-work by which the track is supported above the surface of the ground, of cars disposed in pairs upon each side of the track and frame-work, trucks having wheels journalled at opposite ends and adapted to travel upon the rails, transverse timbers pivoted centrally upon said trucks extending through opposite ends of the upper part of the cars whereby the latter may be suspended therefrom, hangers extending through bridge plates upon the timbers and through the bottom timbers of the car, wheels journalled horizontally to the lower part of each car in the transverse plane of the swivel pins of the suspending timbers, rails or stringers fixed to the supporting posts of the structure in line with the peripheries of the horizontal wheels whereby the latter may contact with and travel upon said stringers whenever the cars oscillate to one side or the other. 5th. The combination with a single track and supporting frame-work, of cars suspended in pairs from transverse timbers passing through each end of the upper part of the cars, said timbers being centrally swivelled upon trucks having wheels at opposite ends which are adapted to travel upon the rails, wheels or rollers journalled horizontally in the lower part of each car in the transverse plane, passing through the pivot points of the suspending beams, and stringers fixed to the frame, slidable boxes in the horizontal plane of travel of the wheels in which the horizontal wheels are journalled and springs whereby they are normally retained in position, said springs yielding to allow an elastic contact of the wheels with the stringers. 6th. The combination with a single line of track and a supporting frame-work, of cars suspended in pairs from transverse timbers which pass through opposite ends of the upper parts of the cars, trucks having wheels at each end adapted to travel upon the rail, central pivots by which the transverse timbers are swivelled to the trucks between the wheels, horizontally disposed wheels or rollers yieldingly journalled to the lower parts of the cars in the transverse planes of the pivot points of the

suspending timbers, hangers or rods, the upper ends of which are passed through plates fixed upon the transverse timbers and the lower ends through the bottom longitudinal timbers of the cars upon the inside and outside respectively, those upon the inner side being diverged so as to embrace the horizontal rollers between the diverging pairs of rods, substantially as described.

**No. 57,580. Smoke Consumer.** (*Foyer fumivore.*)

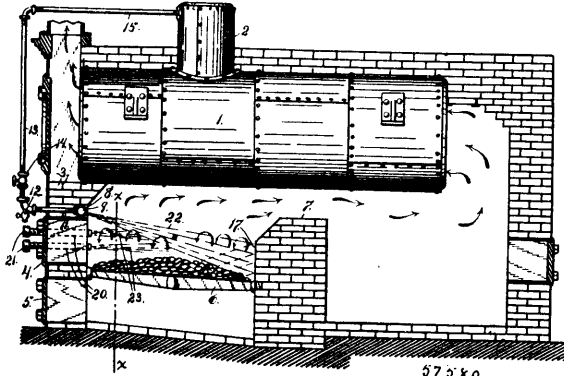

John Henry Saunders, Buffalo, New York, U.S.A., 25th September, 1897; 6 years. (Filed 20th August, 1897.)

*Claim.*—A smoke consumer, consisting essentially of a horizontal pipe centrally arranged in the upper part of the furnace within or next to its front wall and provided throughout its length with a series of fine perforations, for discharging jets of steam in a downward diagonal direction against the inner vertical face of the bridge-wall, and a series of passages through the front wall of the furnace on each side thereof and below the perforated horizontal steam-pipe for admitting a divided current of air to the furnace on each side thereof and in close proximity to the fuel, all operating in the manner and for the purpose stated.

**No. 57,581. Wire Fence Device.**

(*Appareil à clôture de fil de fer.*)

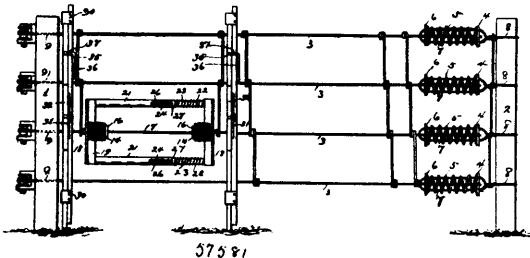

Charley Heitsch, Pontiac, Michigan, U.S.A., 25th September, 1897; 6 years. (Filed 10th September, 1897.)

*Claim.*—The combination with a spacer constructed substantially as described, of a wire-twister, comprising two parallel adjustable bars provided with cross-braces having V-shaped guide recesses and connected by semi-circular ends provided with inwardly projecting arms adapted to support a coil of wire, substantially as and for the purpose set forth.

**No. 57,582. Explosive Alarm Padlock.**

(*Cadenas à avertisseur explosif.*)

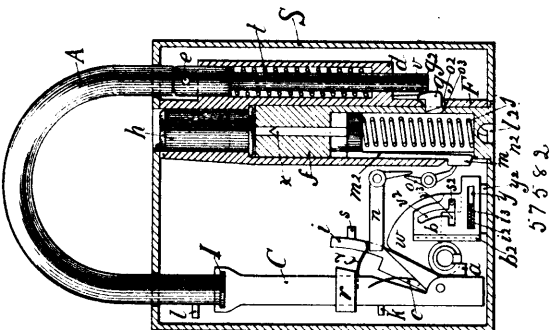

Edward Newell Case, Chicago, Illinois, U.S.A., 25th September, 1897; 6 years. (Filed 27th August, 1897.)

*Claim.*—1st. In an explosive alarm padlock, the shackle A attached by swivel I to connecting rod C, to which is attached

pawl *i* and spring *c*, in combination with double levers *n* and *o*, all arranged and operating to force trigger *m* from edge *n*<sup>2</sup> of barrel F, thereby releasing spring *j*, all operating when tension is brought upon said shackle A, substantially as set forth. 2nd. In an explosive alarm padlock, the spring plunger *r* in combination with dog *g*, slots *o*<sup>2</sup>, *o*<sup>3</sup>, and shackle A, all arranged to automatically lock the firing device, figure 4, to padlock, substantially as set forth. 3rd. In an explosive alarm padlock, the shaft *a*, which is rigidly attached to cam *r*, in combination with tumblers *b*, *b*<sup>2</sup>, *b*<sup>3</sup>, and trigger *m*, all arranged so that the proper key will open the lock without forcing trigger *m* from its position on edge *n*<sup>2</sup> of barrel F, substantially as shown and described. 4th. In an explosive alarm padlock, the spring *o*<sup>2</sup> in combination with the lever *n*, substantially and for the purpose specified. 5th. In an explosive alarm padlock, the slot *l*<sup>3</sup>, figures 1, 4 and 5 in combination with the knob I on the key figure 8, substantially as and for the purpose described. 6th. In an explosive alarm padlock, the barrel F, provided with the edge *n*<sup>3</sup>, in combination with the trigger *m*, substantially as shown and for the purpose specified.

**No. 57,583. Machine for Making Cigars.**

(*Machine à faire les cigares.*)

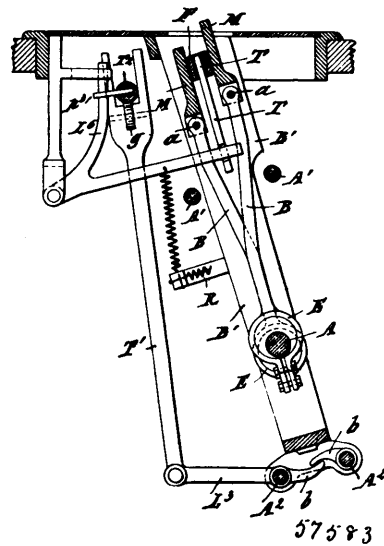

Joseph Lacoste, Brussels, Belgium, 25th September, 1897; 6 years. (Filed 10th March, 1896.)

*Claim.*—1st. In a machine for rolling cigars, a support for the cigar, jaws adjacent to the support and grasping the cigar, and means for moving the said jaws towards and away from the cigar, and at the same time having a motion of ascent and descent whereby the cigar will be caused to roll between the jaws, substantially as described. 2nd. In a machine for rolling cigars, a support for the cigar, jaws on each side of the support and grasping the cigar, a clip adjacent to one end of the cigar and grasping the cigar, and means imparting motion to the jaws whereby they will have a motion of ascent and of descent, and will be opened and closed from the cigar alternately, substantially as described. 3rd. In a machine for rolling cigars, a support for the cigar, two or more jaws on each side of the support and grasping the cigar, and means for imparting motion to the jaws, whereby they will be moved up and down and toward and away from the cigar, substantially as described. 4th. In a machine for rolling cigars, a spring clip surrounding one end of the cigar and having teeth upon its outer face, of a rack or racks engaging with said teeth for imparting a rotary motion to the clip, substantially as described. 5th. In a machine for rolling cigars, of means for actuating the leaf roller in the shape of a divided sleeve, with a combining spring, and toothed on the outside to engage in two rigid racks with eccentric straps, and opening and closing alternately to turn the sleeve loosely on the one part, and to follow on the other part the rotation of the cigar, under the influence of the jaws. 6th. In a machine for rolling cigars, as above set forth, of means for the simultaneous control of the knives, of the holding finger upon the point, of the final opening of the clips, and the ejector traversing the bottom of the mould, and the automatic disengaging of the machine by a single disengaging bar, and in combination with these movements automatic disengaging mechanism controlled by one of the eccentrics of the machine, or the cam in corresponding position to stop the machine with all its parts open.

**No. 57,584. Tool.** (*Outil.*)

John Pearce Hutchins, Oakland, Texas, U.S.A., 25th September, 1897; 6 years. (Filed 27th August, 1897.)

*Claim.*—The herein-described tool, comprising a handle having a facial groove in one side bounded by ribs grooved in their inner

sides, and having a portion extended to form a jaw, a slotted extension at the base of the jaw, a movable jaw operating through the

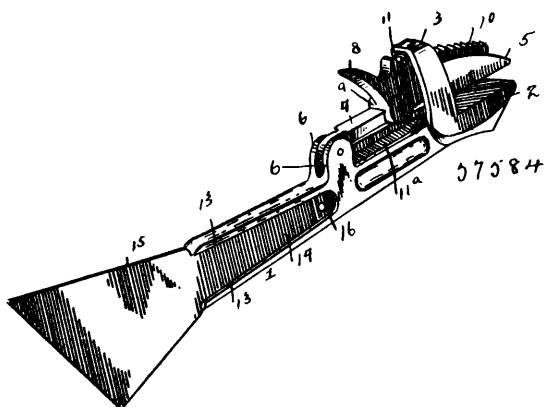

slotted extension and having pivotal connection with ears projecting from the handle, a wedge slidingly mounted upon the shank of the pivotal jaw, and provided with a finger-hold, and having its outer surface notched or serrated to make positive engagement with the outer closed end of the aforesaid slotted extension, through which it operates, a spring interposed between the fixed and pivoted jaws and a scraper-blade having detachable connection with the recessed side of the handle, substantially in the manner set forth for the purpose described.

**No. 57,585. Transportation System.**  
(Système de transportation.)

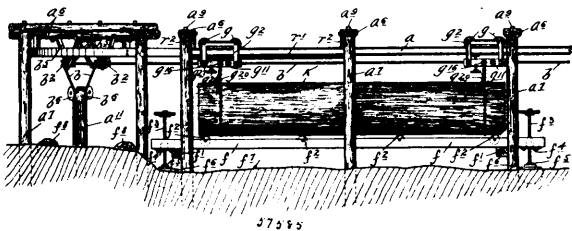

Wallace Grosvenor, Casselton, North Dakota, U.S.A., 25th September, 1897; 6 years. (Filed 7th January, 1897.)

*Claim.*—1st. The combination with a truck and chain, of a chain holding and releasing device comprising a keeper or abutment, a hook, and a removable detent, all mounted on said support and so arranged that said detent may be moved through an end link of the chain, and that any desired link of the opposite end of said chain may be engaged over said hook, substantially as described. 2nd. The combination with a truck of a holding and releasing device comprising a keeper, a screw-shaft and a hook, on said truck, with said parts so arranged that the end of said shaft may be moved through an end link of the chain and that any desired link of the opposite end of said chain may be engaged over said hook, substantially as and for the purposes set forth. 3rd. The combination with the trucks and the chain-holder, screw-shafts having pinions thereon, of the releasing racks in the line of travel engageable with said pinions, for automatically releasing the load, substantially as described. 4th. The combination with a pair of trucks having the chain-holder, screw-shafts provided with pinions, staggered in respect to each other, of the pair of releasing-racks in the line of travel, staggered in respect to each other, for co-operation with said pinions, substantially as described. 5th. The combination with the trucks, of the chain-holding screw-shafts thereon, provided with pinions, and the pair of releasing-racks for co-operation with the holder of the rear truck, one of which racks is laterally movable in respect to the other for adaptation to logs of different lengths, substantially as described. 6th. The combination with the track, the trucks and the travelling cable, of the grip mechanism comprising the jaws  $g^5$  loosely threaded on the studs  $g^6$ , the springs  $g^7$ , tending to throw said jaws apart, and a power device for positively forcing said jaws together, substantially as described. 7th. The combination with the track, the trucks and the travelling cable, of the grip mechanism comprising the jaws  $g^5$  loosely threaded on the studs  $g^6$ , the spring  $g^7$ , the screw-shaft  $g^8$  carrying the inner member of said jaws, the pinions  $g^{11}$  on said shafts  $g^8$ , and the releasing-rack  $g^{12}$ , in the line of travel, engageable with said pinions to release the grips from the cable, substantially as described. 8th. The combination with the elevated track, the trucks and the travelling cable, of the loading platform and the hand screws for raising and lowering said platforms, substantially as and for the purposes set forth. 9th. The track structure, comprising the upright  $a^7$ , the cross-ties  $a^6$  made fast to

said uprights, the brackets  $a^1$ , secured to said cross-ties at their upper ends and spread at their lower ends, the rails  $a$ , made fast to the outer sides of the lower ends of said brackets, and the filling rail or pieces  $a^2$  secured between the spread lower ends of said brackets, substantially as described.

**No. 57,586. Chair. (Chaise.)**

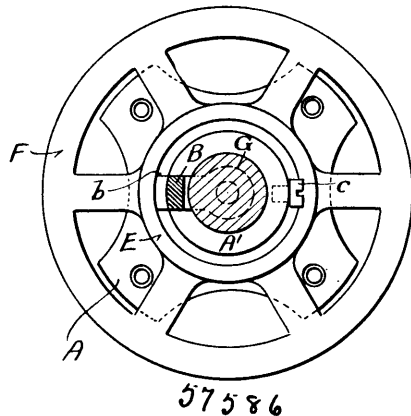

Harry Wilbur Bolens, Port Washington, Oganher County, Wisconsin, U.S.A., 25th September, 1897; 6 years. (Filed 11th September, 1897.)

*Claim.*—1st. The combination of a chair-base casting, a suitably notched non-rotative support guided in the casting longitudinally of the same, an adjusting nut for the support, and a seat iron pivot that engages said support within the circumference of the nut and has frictional contact with said casting. 2nd. The combination of a chair-base casting, a suitably notched non-rotative support guided in the casting longitudinally of the same, an adjusting-nut for the support, a support-engaging pivot within the circumference of the nut having a fractional contact with said casting, and a seat-iron on the pivot in contact with the top of said support. 3rd. The combination of a chair-base casting, a suitably notched non-rotative support guided in the casting longitudinally of the same, an adjusting-nut for the support held against lateral play and longitudinal displacement, a support-engaging pivot within the circumference of the nut having frictional contact with said casting, and a seat-iron on the pivot in contact with the top of the support. 4th. The combination with a chair-base casting, a suitably notched non-rotative support guided in the casting longitudinally of the same, an adjusting-nut for the support and a seat-iron pivot that has bearing contact with the bottom of said support within the circumference of the nut as well as a frictional contact with said casting. 5th. The combination of a chair-base casting, a suitably notched non-rotative support guided in the casting longitudinally of the same, an adjusting-nut for the support held against lateral play and longitudinal displacement, and a support engaging pivot within the circumference of the nut having frictional contact with said casting.

**No. 57,587. Stool. (Tabouret.)**

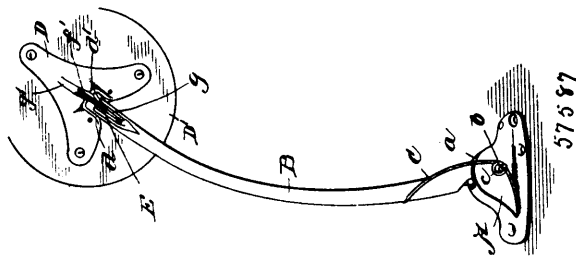

Albert R. Milner, Canal Dover, Ohio, U.S.A., 25th September, 1897; 6 years. (Filed 8th September, 1897.)

*Claim.*—1st. The combination of a base, a spring-actuated leg pivoted to the base, the leg B, provided with a groove  $g$ , (or a drilled hole instead of a groove  $g$ ), the pivoted plate D, provided with a groove  $g^1$  (or a drilled hole instead of a groove  $g^1$ ), stops  $d^1$ , the spring E, provided with tangs  $f$ , and  $f^1$ , the seat  $D^1$ , secured to the plate D, substantially as and for the purpose specified. 2nd. The combination of a base, a spring-actuated leg pivoted to the base, the leg provided with a groove or hole, a pivoted plate provided with a groove or hole, the plate having stops, to hold it in a horizontal position, a suitable spring to actuate the plate, a seat secured to the plate, a suitable spring to actuate the leg, substantially as and for the purpose set forth.



**No. 57,588. Bottle. (Bouteille.)**

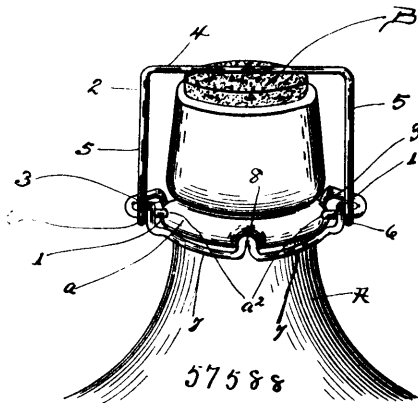

Pardon A. Campbell, Porterville, California, U.S.A., 25th September, 1897; 6 years. (Filed 13th September, 1897.)

*Claim.*—1st. In a bottle having openings therein, a cork in said neck lying across the openings, a pin through said openings and the cork, and means provided upon said pin whereby the bottle neck can be broken to free the pin from the neck, substantially as described. 2nd. In a bottle, a neck having a portion of thin material, said portion being provided with openings, a cork in the neck across said openings, and means pivoted upon said pin whereby the thin portion of the neck can be broken, substantially as described. 3rd. In a bottle, a neck having openings in the side thereof, a cork in the neck over said openings, and pin through said openings and the cork, a member lying against the bottle neck and pivoted to the pin, and arms extending from said member, whereby the member can be forced against the bottle neck to break the same and permit the cork to be withdrawn. 4th. In a bottle, a neck having openings in the sides thereof, a cork over said openings, a pin extending through said openings and the cork, a member pivoted upon said pin and lying against the bottle neck, and arms extending from said member, whereby it can be forced against the bottle neck to break the same and permit the cork to be withdrawn, substantially as described. 5th. In a bottle, a neck having openings in the sides thereof, a cork in said neck over said openings, a pin extending through said openings and the cork, and a yoke pivoted upon said pin, said yoke having a top portion, arms extending from said top portion, eyes upon said arms, and a curved portion extending from the sides, said curved portion being provided with a point adapted to bear against the bottle neck and break the same, whereby the cork can be withdrawn, substantially as described. 6th. In a bottle, a neck having a bead thereon, said bead being provided with openings in the side thereof, a cork in said neck over the openings, a pin through said openings and the cork, said pin having its ends upturned and lying upon the bead, and arms upon the pin, whereby the upturned ends can be forced upon the bead to break the same, and thus permit the withdrawal of the cork, substantially as described. 7th. In a bottle, a neck, a bead formed upon said neck, said bead having openings in the sides thereof, a cork in said neck across said openings, a pin through said openings and the cork, said pin having upturned ends lying upon the bead, a member pivoted upon said pin and lying about the bottle neck, said member bearing against the underside of the bead, and arms extending from said member across the upturned ends of the pin, said arms lying on the side of the pin ends next to the member bearing against the underside of the bead, substantially as described.

**No. 57,589. Children's Undervest.**

(Vêtement d'enfant.)

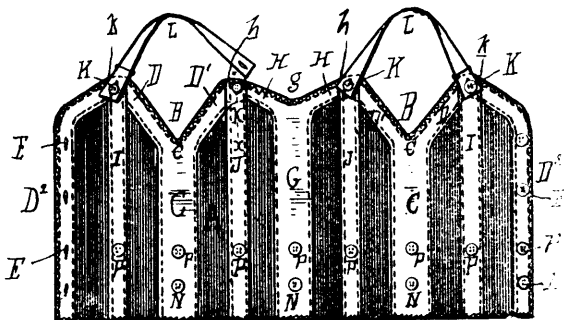

Isaac Newton Fooks, Delaware, U.S.A., 25th September, 1897; 6 years. (Filed 13th September, 1897.)

*Claim.*—1st. In a child's low-necked undergarment, the combination of the body portion extending only to a point below the shoulder and having arm-notches open at the top and further having vertical reinforcing-strips secured to the body of the garment immediately below the arm-notches and continuing laterally along each side of the said arm-notches for reinforcing the upper edges, the rear portions thereof of both arm-notches uniting across the upper edge of the garment at the back. 2nd. In a child's undergarment, the combination of the body portion having arm-notches at the top, with vertical reinforcing-strips secured to the body of the garment immediately below the arm-notches and continuing upon each side of the arm-notches and uniting across the upper edge for reinforcing the edges of the garment, and detachable shoulder-straps detachably connected to the upper reinforced edges of the garment upon each side of the arm-notches. 3rd. In a child's low-necked undergarment, the combination of the body portion having arm-notches open at the top, with vertical reinforcing strips secured to the body of the garment immediately below the arm-notches and continuing integrally upon each side of the arm-notches for reinforcing the edges of the garment, and shoulder-straps detachably connected to the upper reinforced edges of the garment upon each side of the arm-notches and provided with means for adjusting their length. 4th. In a child's undergarment, the combination of the body portion having arm-notches at the top, with vertical reinforcing-strips secured to the body of the garment immediately below the arm-notches and continuing upon each side of the arm-notches for reinforcing the edges of the garment, additional vertical reinforcing-strips secured to the body portion and terminating upon the upper reinforcing-strips at the top to one side of the strips below the arm-notches, and shoulder-straps detachably connected with the upper ends of the last-mentioned or additional reinforcing-strips. 5th. In a child's undergarment, the combination of the body portion having arm notches at the top, with vertical reinforcing-strips secured to the body of the garment immediately below the arm-notches and continuing upon each side of the arm-notches for reinforcing the edges of the garment, an additional vertical reinforcing-strip secured to the body portion in the back and having lateral extensions terminating upon the upper reinforcing-strips at the top to one side of the arm-notches, shoulder-straps detachably connected with the upper portions of the reinforcing strips upon each side of the arm-notches and provided with means for adjusting the length of the shoulder-straps, and means upon the waist portion of the last-mentioned or additional reinforcing-strips for sustaining a lower garment. 6th. In a child's undergarment, the combination of the body portion having arm-notches at the top, with vertical reinforcing-strips secured to the body of the garment immediately below the arm-notches and continuing upon each side of the arm-notches for reinforcing the edges of the garment, additional vertical reinforcing-strips secured to the body portion and terminating upon the upper reinforcing-strips at the top to one side of the strips below the arm-notches, shoulder-straps detachably connected with the upper ends of the last mentioned or additional reinforcing-strips, and a central vertical reinforcing strip at the back of the garment having its upper end formed with lateral extensions secured to the upper edge of the body portion and extending to the juncture of the shoulder-straps and additional vertical reinforcing-strips. 7th. In an undergarment, the combination of the body portion A, having the arm-notches B, with reinforcing-strips C, arranged below the arm-notches and extended laterally at the top to bound the upper edge of the body portion forming the arm-notches and in which one of said portions is extended as at D<sup>2</sup>, to bound the upper and vertical free edges of the body portion, and a middle back reinforcing-strip G, having lateral bounding-strips H, H, at the top which meet the other lateral bounding-strips of the parts C, C. 8th. In an undergarment, the combination of the body portion A, having the arm-notches B, with vertical reinforcing-strips C, arranged below the arm-notches and extended laterally at the top to bound the upper edge of the body portion forming the arm-notches and in which one of said portions is extended as at D<sup>2</sup>, to bound the upper and vertical free edges of the body portion, a middle back reinforcing-strip G, having lateral bounding-strips H, H, at the top which meet the other lateral bounding-strips of the parts C, C, and shoulder-straps detachably connected with the reinforcing bounding-strips upon each side of the arm-notches. 9th. In an undergarment, the combination of the body portion A, having the arm-notches B, with reinforcing-strips C, arranged below the arm-notches and extended laterally at the top to bound the upper edge of the body portion forming the arm-notches and in which one of said portions is extended as at D<sup>2</sup>, to bound the upper and vertical free edges of the body portion, a middle back reinforcing-strip G, having lateral bounding-strips H, H, at the top which meet the other lateral bounding-strips of the parts C, C, shoulder-straps detachably connected with the reinforcing bounding-strips upon each side of the arm-notches, and vertical reinforcing-strips I, J, secured to the body of the garment in alignment with the shoulder-straps and furnished at the waist with means for attachment to a lower garment.

**No. 57,590 Lock Hinge. (Gond de serrure.)**

John Landon Fiske, Cambridge, assignee of Gustaf Libert Reens-tierna, Boston, both in Massachusetts, U.S.A., 27th September, 1897; 6 years. (Filed 10th September, 1897.)

*Claim.*—The herein described lock-hinge, consisting of a pair of discs having teeth upon their approaching faces, said teeth being

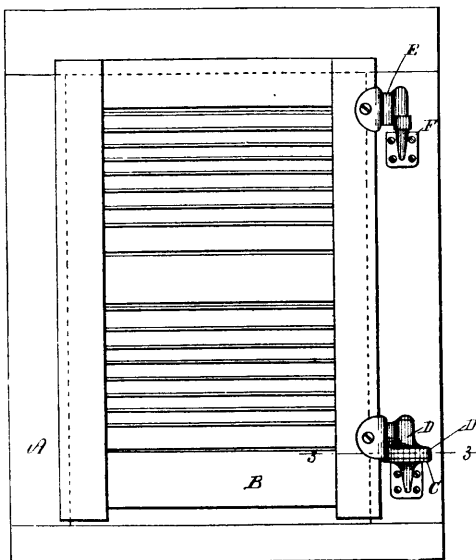

57590

arranged inward away from the outer edges of the discs, one of said discs being secured to a window frame or the like, and the other disc secured to a blind or the like, and a releasing device for said hinge consisting of a spindle journaled on the said blind or the like, on a line with the lower disc, and having a cam at one end which is arranged to have a partial rotation between the faces of said discs, near the edges thereof, and to bear upon the upper face of the lower disc, and an operating handle having one end fixed to said spindle, and its other end projecting outward from the blind, substantially as described.

**No. 57,591. Paper Box. (Boite à papier.)**

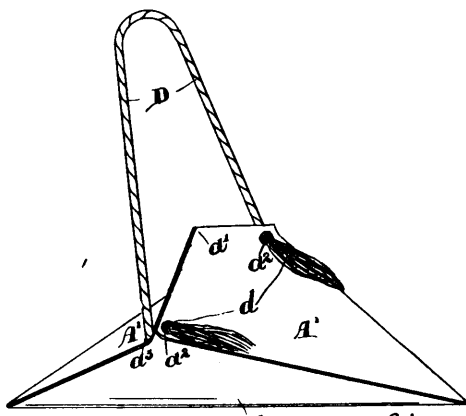

Edgar Finch and Thomas Bell, both of Toronto, Ontario, Canada, and Robert James Bell, New York, State of New York, U.S.A., 27th September, 1897; 6 years. (Filed 15th September, 1897.)

*Claim.*—1st. A box comprising the two bottom triangular sides having a longitudinal central fold, and the top folding flaps forming triangular ends and meeting in a cross ridge in the centre of the box, and means for fastening the flaps together, as and for the purpose specified. 2nd. A box comprising the two bottom triangular sides, having a longitudinal central fold, and the top folding flaps forming triangular ends, and meeting in a cross ridge in the centre of the box, projecting apexes  $a^1$ , and means for fastening the flaps together as and for the purpose specified. 3rd. A box comprising the two bottom triangular sides, having a longitudinal central fold, and the top folding flaps forming triangular ends, and meeting in a cross ridge in the centre of the box, projecting apexes  $a^1$ , opposing holes in the projecting apexes of the lower and upper flaps at one side, and holes in the projecting apex of the upper flap at the opposite side and a cord passing through the opposing holes and designed to fasten the box together and form a carrying loop therefor, as and for the purpose specified.

**No. 57,592. Boiler Furnace. (Fournaise de chaudières.)**

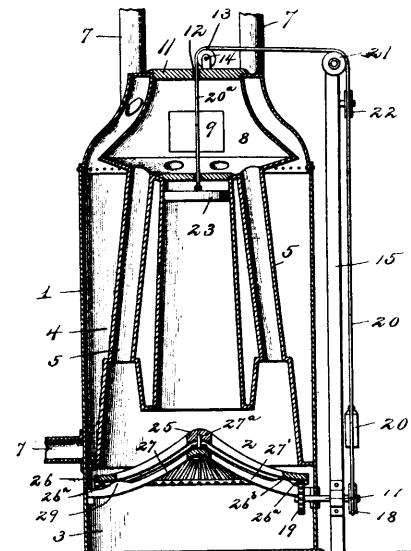

August Rahner and Charles W. Beresford, both of Villisca, Iowa, U.S.A., 27th September, 1897; 6 years. (Filed 16th September, 1897.)

*Claim.*—1st. In boiler furnaces, the combination of a furnace having a grate and a coal magazine above said grate a follower to press the said coal down upon the grate, and means actuated by the said follower for moving the grate and clearing the same of clinkers and ashes, substantially as described. 2nd. In boiler furnaces, the combination of a furnace having a grate, a coal magazine above the same, and a door for supply of coal to said magazine, a follower in the magazine to press the coal down upon the grate, and mechanism actuated by said follower to cause the rotation of the grate, substantially as described. 3rd. In boiler furnaces, the combination of a furnace having a grate, and a coal magazine above the same, a standard alongside the exterior wall of the furnace, a follower within the coal magazine and adapted to press the coal down upon the grate, means for effecting the rotation of the grate, and a chain or rope passing around pulleys on the said standard and having one end connected with the said follower and the other end thereof adapted to operate the said grate rotating mechanism, substantially as described. 4th. In boiler furnaces, the combination of a furnace provided with a coal magazine and a grate below the same, a coffer closing the top of the furnace and provided with an opening, a standard on the exterior side of the furnace, a follower within the coal magazine to press the coal down upon the grate, a connection between the said standard and the grate for effecting the rotation of the latter, and a chain or cord having one end passed through said opening in the coffer and connected with the said follower, and the other end thereof passing around pulleys on the said standard and provided with a counter-balancing weight adapted to effect the operation of the said grate-rotating mechanism, substantially as described. 5th. In boiler furnaces, the combination of the furnace provided with a coal magazine and a door for replenishing the same, a coffer plate closing the opening to the furnace above said magazine and provided with an opening, a grate support in the ash box provided with a pivot, a cone-shaped grate formed with an opening at the apex thereof by which it is mounted upon said pivot and having a base or rim formed with gear teeth, a standard extending alongside of the furnace and provided with a crossshaft projecting through the furnace wall, and having a gear meshing with the teeth on the grate rim, a weighted follower within the coal magazine and adapted to press the coal down upon the grate, and a cord or chain passed through said opening in the coffer plate, and having one end connected with said follower and the other end thereof passed over pulleys on the said standard, and connected with the said cross shaft, whereby a given coal forcing movement on the part of the follower will effect a corresponding rotating movement of the grate, substantially as described.

**No. 57,593. Carrying Frame. (Brancard.)**

Henrik Emil Herbert Borgstrom, Trekanten, Helsingfors, 27th September, 1897; 6 years. (Filed 9th September, 1897.)

*Claim.*—1st. A carrying device consisting of two rods or bars, each of which is provided at each end with a curved or yoke-shaped shoulder piece which is padded on the undersides or surfaces and adapted to conform to the shape of the shoulders, substantially as shown and described. 2nd. In a carrying frame provided at each end with two or more projecting rods or bars, said

rods or bars being each provided at their outer ends with curved-yoked-shaped shoulder pieces, said shoulder pieces being provided

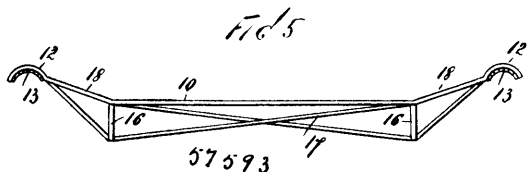
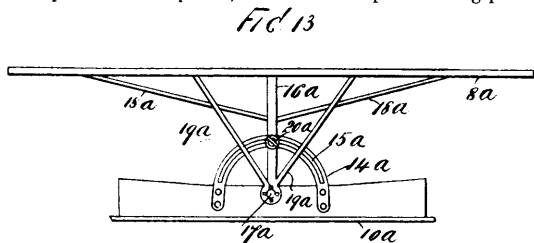

with adjustable pads on their undersides or surfaces which are also curved or yoke-shaped in form, substantially as shown and described. 3rd. A carrying frame provided with projecting rods or bars being provided with yoke-shaped shoulder pieces, and semicircular or segmental pads, substantially as shown and described. 4th. A carrying device from which a load of any kind may be suspended, or to which a load may be attached or secured, provided with a plurality of shoulder pieces at each end thereof, said shoulder pieces being curved or yoke-shaped in form, substantially as shown and described. 5th. A bar or frame, provided with a support for carrying persons, objects or things, which is connected therewith, and adapted to retain a horizontal position, regardless of the position in which the ends of the bar or frame are held, substantially as shown and described. 6th. A carrying frame provided with a suitable support for the object to be carried, said support being connected therewith, and adjustable therein or thereon so that it will remain in a horizontal position, regardless of the position in which the ends of the carrying frame are held, substantially as shown and described. 7th. A carrying frame, provided with a support pivotally connected therewith, and suspended therefrom, said support being also provided with devices whereby it may be held in a horizontal position, at all times, regardless of the position of the frame, substantially as shown and described. 8th. A carrying frame, consisting of two separate side frames, between which is mounted a suitable support for a person or object to be carried, said support being provided with a curved or segmental plate adjacent to the frame of which is formed a curved or segmental slot, and a set screw which passes through said frame, and said slot, whereby the support may be adjusted to and held in a horizontal position regardless of the position of the frame, substantially as shown and described.

**No. 57,594. Bottle. (Bouteille.)**

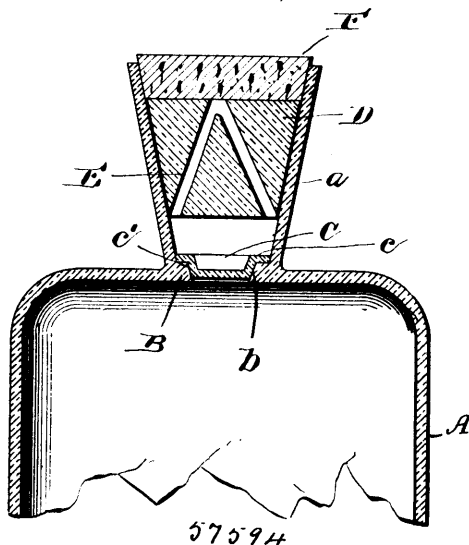

John S. McWhorter and Minter Earle Jackson, both of Janelw, West Virginia, U.S.A., 27th September, 1897; 6 years. (Filed 16th September, 1897.)

*Claim.*—1st. A bottle formed with a tapered neck provided with a valve adapted to be seated at the lower end of said neck, and a stopper permanently fixed within said neck and having passages therethrough, substantially as and for the purpose specified. 2nd. A bottle having a tapered neck and an annular interior flange at the lower end thereof, combined with a flanged stopper adapted to be seated on the flange of the neck, and a tapered cork permanently fixed within the neck above said valve and having passages extending therethrough and terminating at the outer edge of the lower end of the stopper, substantially as described. 3rd. A bottle having a tapered neck and an annular interior flange at the lower end thereof, combined with a flanged stopper adapted to be seated on the flange of the neck, and a tapered cork permanently fixed within the neck above said valve and having passages extending therethrough and terminating at the outer edge of the lower end of the stopper, the diameter of said valve being less than the diameter of the lower end of the stopper, substantially as described.

**No. 57,595. Combined Sash Lock and Holders. (Arrête-croisêe.)**

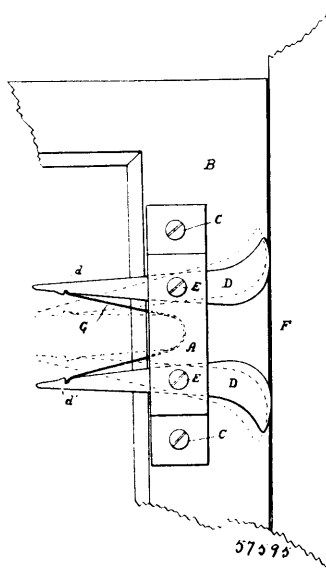

Titus Becker, New Dundee, Ontario, Canada, 27th September, 1897; 6 years. (Filed 10th September, 1897.)

*Claim.*—1st. The combination of the metal holder A, lever cams D, and spring G, secured to face of sash B by screws C, substantially as and for the purpose set forth. 2nd. The combination, with the metal holder A, lever cams D, and spring G, said parts secured to face of sash B by screws C, substantially as and for the purpose set forth. 3rd. The combination of the metal holder H, lever cams D, and spring G, morticed into end of sash B, and secured thereto by screws C, substantially as and for the purpose set forth. 4th. The combination, with the metal holder H, lever cams D, and spring G, morticed into end of sash, and secured thereto, substantially as and for the purpose set forth.

**No. 57,596. Carbon Brush for Electric Apparatus. (Brosse à carbones pour appareil électrique.)**

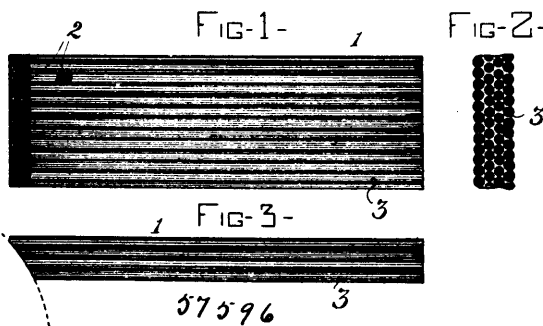

The Canadian General Electric Company, Toronto, Ontario, Canada, assignee of Elihu Thomson, Swampscott, Mass., U.S.A., 27th September, 1897; 6 years. (Filed 21st May, 1897.)

*Claim.*—1st. A commutator brush for dynamos, motors or similar electric apparatus, composed of rods or pieces of carbon assembled in a mass and held together by interposed films adhering to the pieces. 2nd. A commutator brush for dynamos, motors or similar electric apparatus, composed of rods or pieces of carbon assembled in a mass and held together by interposed metallic films adhering to the pieces, and provided with an external case. 3rd. A carbon brush composed of rods of carbon of greater or less length, plated over with metal and united by soldering, as described. 4th. A carbon brush, composed of rods coated or plated with metal in films over the exterior of the rods, and united laterally by soldering or fusing, as described. 5th. A carbon brush, composed of rods or pieces of carbon coated or plated over the exterior with thin layers of metal, soldered, plated or fused together into a mass and encased by a thin casing of metal, as described. 6th. The herein-described method of forming commutator brushes, which consists in plating pieces of carbon with a thin film of metal, assembling said pieces of carbon together, and uniting them by soldering or sweating. 7th. The herein-described method of forming commutator brushes, which consists in assembling and soldering together pieces of carbon coated with a thin film of metal and encasing the bundle of metallic-coated carbons in an outer metallic coating.

**No. 57,597. Carbon Brush for Electric Apparatus.**

(*Brosse à carbones pour appareil électrique.*)

FIG-1-



FIG-2

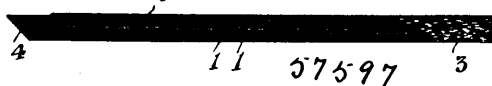

57597

The Canadian General Electric Company, Toronto, Ontario, Canada, assignee of Elihu Thomson, Swampscott, Mass., U.S.A., 27th September, 1897; 6 years. (Filed 21st May, 1897.)

*Claim.*—1st. A commutator brush made of filamentary carbon coated with metal, and mounted in a casing for strengthening it. 2nd. A commutator brush, composed of filamentary carbon connected together in layers or strips of the required thickness and size for the brush and united at one end, while at the other end the filamentary layers or strips are separate and elastic. 3rd. A commutator brush, composed of carbonized fibrous material of woven texture, the layers of which are plated with metal and assembled together to the required thickness. 4th. A commutator brush, composed of carbonized fibrous material of woven texture, the layers of which are plated with metal and assembled together to the required thickness and are united at one end and inclosed with a strengthening casing. 5th. A flexible commutator brush, made of carbonized strips of fibres, the fibres inclosed or incased in conducting metal, whereby their conductivity is increased, and their elasticity and strength is also increased. 6th. A commutator brush formed of filaments of carbon coated with metal, secured together at one end and loose at the other. 7th. A commutator brush formed of filaments of carbon coated with metal, secured together at one end and free at the other end, and provided with a strengthening casing. 8th. A commutator brush formed of filaments of carbon coated with metal and woven together, and arranged in layers secured together at one end and free at the other end. 9th. A commutator brush formed of layers of woven filaments of carbon coated with metal, and arranged in layers secured together at one end and free at the other end, with a strengthening casing.

**No. 57,598. Sash Fastener. (Arrête-croisée.)**

Charles Summer Roberts, New Haven, Connecticut, U.S.A., 27th September, 1897; 6 years. (Filed 8th September, 1897.)

*Claim.*—1st. In a sash fastener, comprising two racks united with the window sash and frame respectively, and means whereby said racks may be engaged or disengaged at will, substantially as shown and described. 2nd. In a sash fastener, two racks attached respectively to the window frame and to the sash, means for releasing said racks from each other, and means whereby said racks as released will automatically disengage themselves from each other, substantially as shown and described. 3rd. In a sash fastener, two racks attached respectively to the window sash and to the frame, means for engaging and disengaging the teeth of said racks, a spring whereby said racks are normally held out of contact with each other, substantially as shown and described. 4th. In a sash fastener, two racks attached respectively to the window sash and to the frame, and a movable wedge whereby said racks are engaged or disengaged at will, substantially as shown and described. 5th. In a sash fastener, two racks attached respectively to the window sash and to the frame, one of said racks being provided with a wedge, adapted to co-operate with a sliding wedge, and means for

sliding said last named wedge, substantially as shown and described. 6th. In a sash fastener, two racks attached respec-

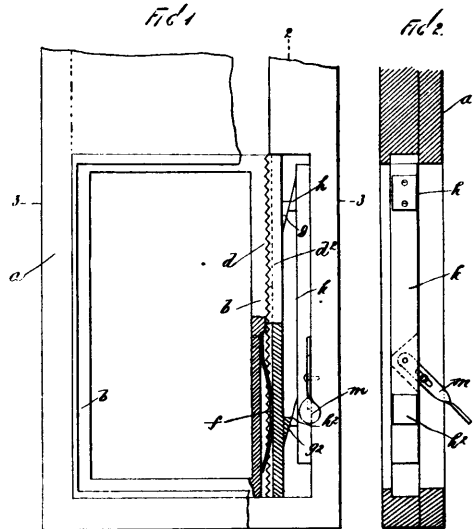

57598

tively to the window sash and to the frame, means whereby said racks are normally held out of contact, and a sliding wedge whereby said racks may be engaged or disengaged at will, and means for sliding said wedge, substantially as shown and described. 7th. In a sash fastener, two racks attached respectively to a window frame and to a window sash, a sliding wedge adapted to engage or disengage said racks, and a lever adapted to operate said sliding wedge, substantially as shown and described.

**No. 57,599. Car Fender. (Defense de chars.)**

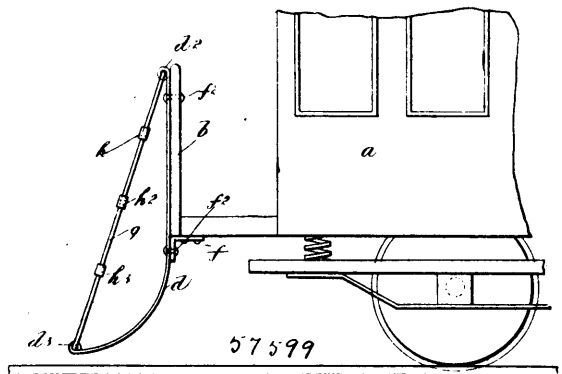

57599

George Wiemers, Brooklyn, New York, U.S.A., 27th September, 1897; 6 years. (Filed 13th September, 1897.)

*Claim.*—1st. In a car fender, the combination with a resilient frame, of means for attaching the same to the car, and removable resilient cross bands, substantially as shown and described. 2nd. In a car fender, the combination with a resilient frame, or rods attached to the car having eyelets by means of which said frame is attached thereto, and resilient removable cross bands, substantially as shown and described. 3rd. In a car fender, the combination with a resilient frame, of rods attached to the car and adapted to support said frame, an auxiliary fender supported by the lower portions of said rod, and resilient removable cross bands, substantially as shown and described. 4th. In a car fender, the combination with a resilient frame, of rods attached to the car having eyelets by means of which said frame is supported, an auxiliary fender supported by the lower portions of said rod, and resilient removable cross bands supported by said frame, substantially as shown and described.

**No. 57,600. Electric Elevator. (Elevateur électrique.)**

Humphrey R. Smith, Chicago, Illinois, U.S.A., 27th September, 1897; 6 years. (Filed 8th June, 1896.)

*Claim.*—1st. In an electric elevator, a hoisting motor, comprising a solenoid having a stationary core, and a movable coil, said coil connected to the car hoisting cable, as and for the purpose set forth.

2nd. In an electric elevator, a hoisting motor comprising a solenoid having a stationary core, and a series of coils, one of said parts

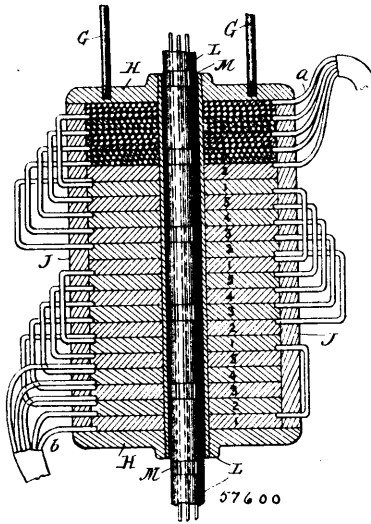

being connected to the car hoisting cable, as and for the purpose set forth. 3rd. In an electric elevator, a hoisting motor comprising a solenoid having a sectional core, and a series of coils, one of said parts being connected to the car hoisting cable, and means for simultaneously exciting two or more of said coils, as and for the purpose set forth. 4th. In an electric elevator, a hoisting motor, comprising a solenoid having a stationary sectional core, and a series of movable coils, said coils connected to the car hoisting cable, and means for energizing simultaneously two or more of said coils, as and for the purpose set forth. 5th. In an electric elevator a hoisting motor comprising a stationary core, a series of movable coils connected to the car hoisting cable, said coils arranged in sets, and means for energizing simultaneously two or more coils of each set, as and for the purpose set forth. 6th. In an electric elevator, a hoisting motor comprising a stationary core, a series of movable coils connected to the car hoisting cable, said coils arranged in sets, means for making circuit simultaneously through two or more coils of each set, said means controllable from the car, as and for the purpose set forth. 7th. In an electric elevator, a hoisting motor comprising a stationary core, a series of movable coils connected to the car hoisting cable, said coils arranged in sets, the corresponding members of each being coupled together in series, and means for energizing two or more of said coupled up sets simultaneously, as and for the purpose set forth. 8th. In an electric elevator, a hoisting motor, comprising a stationary core, a series of movable coils connected to the car hoisting cable, means for successively energizing the coils of said series, as and for the purpose set forth. 9th. In an electric elevator, a hoisting motor, comprising a stationary sectional core, movable coils arranged in sets and connected to the car hoisting cable, means for simultaneously energizing two or more adjacent coils in each set, and means for progressively cutting in and successively cutting out said coils, as and for the purpose set forth. 10th. In an electric elevator, a hoisting motor, comprising a stationary core composed of alternating magnetic and non-magnetic pieces and a series of coils, and means for energizing separated coils of said series, as and for the purpose set forth. 11th. In an electric elevator, a hoisting motor, comprising a solenoid having a sectional core and a series of sets of coils, corresponding coils of each set being electrically coupled up and means controllable from the car for energizing one or more of said coupled up coils, as and for the purpose set forth. 12th. In an electric elevator, a hoisting motor comprising a solenoid having a sectional core and a series of coils arranged in sets, corresponding coils in each set being in electrical connection with each other, means controllable from the car for energizing one or more of said coupled up coils, and means for shifting the energizing current to the next adjacent coupled up coils, as and for the purpose set forth. 13th. In an electric elevator, a hoisting motor, comprising a solenoid having a sectional core, and a series of coils arranged in sets, corresponding coils in each set being in electrical connection with each other, a commutator arranged in circuit with said coils, and means actuated by the movement of said solenoid for operating said commutator, whereby current is shifted from one to another of said coupled up sets of coils, as and for the purpose set forth. 14th. In an electric elevator, a hoisting motor, comprising a solenoid having a sectional core and a series of coils arranged in sets, corresponding coils in each set being in electrical connection with each other, a commutator having as many segments as there are coupled up sets of coils, each segment included in circuit with a coupled up set of coils, and means for moving said

commutator coincidentally with the actuation of said solenoid, as and for the purpose set forth. 15th. In an electric elevator, a hoisting motor comprising a solenoid having a sectional core, and a series of coils arranged in sets, corresponding coils of each set being coupled together, a commutator having its segments respectively included in circuit with said several coupled up sets of coils, a cable arranged to be moved by the actuation of said solenoid, said cable arranged to operate said commutator, as and for the purpose set forth. 16th. In an electric elevator, a hoisting motor, comprising a solenoid having a sectional core and a series of coils arranged in sets, corresponding coils of each set being coupled together, a commutator having its segments respectively included in circuit with said several coupled up sets of coils, brushes arranged to contact with said commutator, means for controlling the circuit through said brushes, and means actuated by said solenoid for moving said commutator, as and for the purpose set forth. 17th. In an electric elevator, a hoisting motor, comprising a solenoid having a sectional core and series of coils arranged in sets, the corresponding coils of each set being coupled together, a commutator having its segments respectively included in circuit with said several coupled up sets of coils, means for actuating said commutator, brushes arranged to contact with said commutator, means controllable from the car for making or breaking the circuit through said brushes and varying the current, as and for the purpose set forth. 18th. In an electric elevator, a hoisting motor, comprising a stationary core, a casing suspended from the car hoisting cable, a coil arranged in said casing, said casing and coil adapted to travel upon said core, and means controllable from the car for energizing said coil at will, as and for the purpose set forth. 19th. In an electric elevator, a hoisting motor, comprising a stationary core, a hollow cylindrical casing, comprising an outer magnetic and an inner non-magnetic sleeve, a coil arranged within said casing, said inner sleeve adapted to be received upon said core, and means for controlling from the car the energizing current of said coil, as and for the purpose set forth. 20th. In an electric elevator, a hoisting motor, comprising a stationary core, a hollow cylindrical casing comprising the end pieces, an inner non-magnetic and an outer magnetic sleeve, a coil arranged in said casing, said casing suitably suspended from the car hoisting cable, and means, controllable from the car, for governing the energizing current of said coil, as and for the purpose set forth.

#### No. 57,601. Expanding Chain Wheel.

(Roue a expansion pour chaines.)

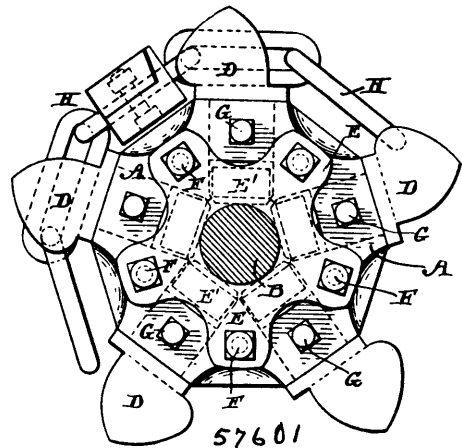

Michael Garland and Charles Prescott, both of Bay City, Michigan, U.S.A., 28th September, 1897; 6 years. (Filed 7th September, 1897.)

*Claim.*—1st. In an expansion wheel for driving chains, the combination with a hub provided with radial openings extending from its eye or driving shaft opening and with openings in one of its faces, independent teeth adapted at their outer ends for receiving a drive chain and their inner ends for bearing on a series of connected wedges, said teeth being adapted to be inserted in the said radial openings, connected wedges inserted in said openings which come in contact with the periphery of the driving shaft of the chain wheel and with the angled or tapered inner ends of the teeth, draw-bolts for acting upon the plate to which the said wedges are connected, whereby the teeth will be forced outward in said radial openings to the extent required to compensate for the wearing away of the teeth or chain, locking nuts upon said draw-bolt and set screws in said hub, substantially as described. 2nd. An expansible chain wheel constructed with independent adjustable teeth and means for adjusting all of the teeth simultaneously and uniformly, said means comprising a plate having a plurality of separated projecting wedges integral therewith and having flat engaging surfaces adapted to engage corresponding flat surfaces upon the inner ends of the said teeth, and means for securing the teeth in their adjusted positions, substantially as described.

**No. 57,602. System of Electrical Transportation.**

(Système de transport électrique.)

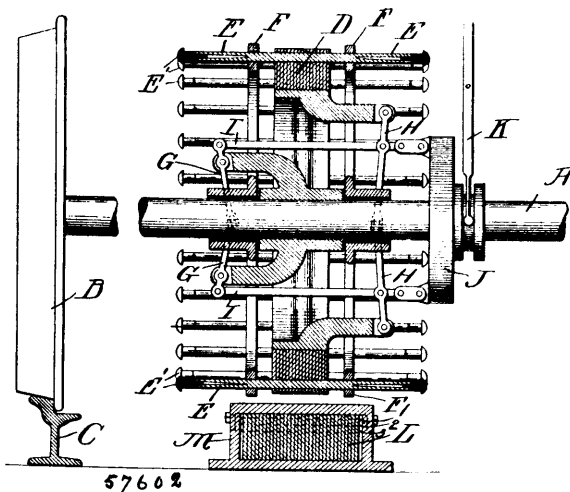

Philip Kossuth Stern, St. Louis, Missouri, U.S.A., 28th September, 1897; 6 years. (Filed 23rd June, 1896.)

*Claim.*—1st. An electric transportation system, consisting of a route or line of travel, a vehicle which is adapted to travel along said route, a primary inducing element, which is arranged along said route, and a laminated wheel, mounted on said vehicle, which wheel is influenced by the primary element, substantially as described. 2nd. An electric transportation system, consisting of a route or line of travel, a vehicle adapted to travel along said route, a primary inducing element arranged along the route, a laminated wheel, mounted on the vehicle, and induced current conductors on said wheel, substantially as described. 3rd. The combination with a suitable axle, of an iron wheel mounted thereon, induced current conductors on said wheel, a primary inducing element which is arranged in proximity to said wheel, said element, when energized by alternating currents of different phases, generating alternate varying polarities, whereby the wheel is caused to rotate by induction, and means on the wheel for varying the resistance of the induced current conductors on said wheel, substantially as described. 4th. The combination with a primary element, which is energized by alternating currents of different phases, of a wheel mounted in proximity thereto, which wheel is rotated by induction, induced current conductors of varying resistance on said wheel, and means for short-circuiting or varying the resistances of said induced current conductors, whereby the movements of the wheel is controlled, substantially as described. 5th. The combination with a primary element, which is energized by altering currents of different phases, of a laminated iron wheel located in proximity thereto, which wheel is rotated by induction, induced current conductors on said wheel, a metallic ring or rings slidingly mounted upon said conductors for the induced currents, substantially as described. 6th. The combination with a core, composed of a series of laminations, insulated from each other, electrical conductors on said core, for conducting a polyphase current, said conductors when energized forming a primary element, a wheel which is mounted in proximity to said element, induced current conductors in said wheel, whose resistance increases towards their ends, and a ring slidingly mounted on said conductors for varying the resistance of the induced currents, substantially as described. 7th. A wheel which is adapted to be rotated by induced currents, said wheel comprising a laminated ring, mounted upon a suitable shaft or axle, induced current conductors which are carried by said wheel, said conductors projecting laterally outside of said wheel, which conductors are so arranged that their conductivity decreases towards their ends, and a ring or rings slidingly mounted upon said conductors for short-circuiting the induced currents. 8th. A wheel, which is adapted to be rotated by induced currents, said wheel comprising laminated rings, induced current conductors which are carried by said ring, and which project laterally from said ring, a ring or rings for varying the resistance of said conductors, said ring being slidingly mounted on the conductors, and insulation buttons in the ends of the conductors, for limiting the movement of the rings, said insulations also affording a seat for the rings, where said rings are out of contact with the induced current conductors, substantially as described. 9th. In a system of electrical transportation, the combination with a vehicle, which is adapted to travel along a route or line of travel, a primary element which is arranged along the said route, a secondary rotary inducing member, which is carried by said vehicle, and in inductive relationship to said primary element, said secondary member being adapted to propel the vehicle, and means for varying the torque of said secondary member, substantially as described.

**No. 57,603. Pipe Wrench. (Clé à écrou.)**

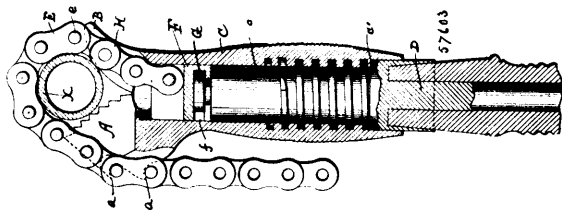

Jay Kyle Sheffy, Chicago, Illinois, U.S.A., 28th September, 1897; 6 years. (Filed 23rd December, 1896.)

*Claim.*—1st. In a pipe-wrench, the combination with a handle-bar, and a chain attached to the end of the bar by a swivelled joint, of a shank sleeved upon the handle-bar and in screw-threaded engagement therewith, and a serrated jaw carried by the shank and having its back adapted to engage the chain. 2nd. In a pipe-wrench, the combination with a handle-bar, and a chain attached to the handle-bar by a swivelled joint, of a shank sleeved upon and in screw-threaded engagement with the handle-bar, the shank and handle-bar having smooth co-operating bearing surfaces upon each side of their co-operating screw-threaded portions, and a jaw fixed upon the shank for co-operating with the chain and having its back adapted to engage the chain. 3rd. In a pipe-wrench, the combination with a handle-bar, and a chain attached to the end of the handle-bar by a swivelled joint, of a shank sleeved upon and in screw-threaded engagement with the handle-bar and carrying a jaw for co-operating with the chain, the throat of the shank aperture being oblong in cross-section, its major diameter being parallel with the plane of action of the chain, the chain having a thickened portion near its attached end to limit its inward movement. 4th. In a pipe-wrench, the combination with a tubular jaw carrying shank, and a handle-bar adapted to fit within the shank and being in screw-threaded engagement therewith, of a chain, a swivel block attached to the chain and having a transverse T-socket in one end, and a T-shank on the end of the handle-bar for engaging the socket. 5th. The combination with a handle-bar, a chain attached to the handle-bar by a swivelled joint, and a tubular shank sleeved upon the bar and in screw-threaded engagement therewith, the shank and bar having co-operating smooth bearing surfaces upon each side of their screw-threaded sections, of a pair of relatively flaring bifurcated jaws mounted upon the end of the shank, one of such jaws having a serrated face, hooks or notches on the back of such jaw, and laterally projecting studs carried by the chain for engaging such hooks or notches, all substantially as described and for the purposes set forth.

**No. 57,604. Lifting Jack. (Cric.)**

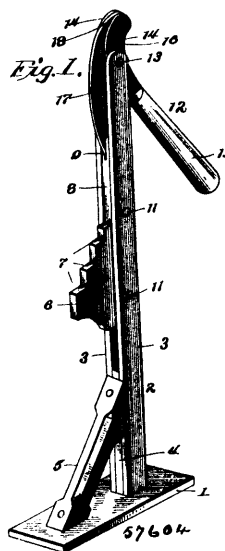

Arthur W. Murphy, Harvey Bank, New Brunswick, Canada, 28th September, 1897; 6 years. (Filed 17th September, 1897.)

*Claim.*—1st. A lifting jack, comprising a supporting standard, a lifting block carried thereby, an operating lever fulcrumed upon said standard, and a link connecting the lever with the lifting block, the point of connection of the link with the lever being so arranged as to pass beyond the fulcrum point of the lever, whereby the latter is locked by the strain incident to lifting, substantially as described.



2nd. A lifting jaw, comprising a supporting standard, a lifting block carried thereby, an operating lever fulcrumed upon said standard, and a link connecting the lever with the lifting block, the connected ends of the lever and link being curved, whereby the point of connection there between is adapted to pass beyond the fulcrum point of the lever for locking the latter by the strain incident to lifting, substantially as described. 3rd. A lifting jack, comprising a supporting standard, a lifting block slidably arranged therein, an operating lever fulcrumed upon said standard, and a link connecting the lever with the lifting block, the connected ends of the lever and link being curved, whereby the point of connection there between is adapted to pass beyond the fulcrum point of the lever for locking the latter by the strain incident to lifting, substantially as described. 4th. A lifting jack, comprising a supporting standard, a lifting block slidably arranged therein and provided with a series of slots, pins passing through the standard and said slots, whereby the lifting block is retained within the standard, an operating lever fulcrumed within the standard and arranged above the lifting block, and a link connecting the lever with the lifting block, the connected ends of the lever and link being curved, whereby the point of connection there between is adapted to pass beyond the fulcrum point of the lever for locking the latter by the strain incident to lifting, substantially as described.

**No. 57,605. Car Coupler. (Attelage de chars.)**

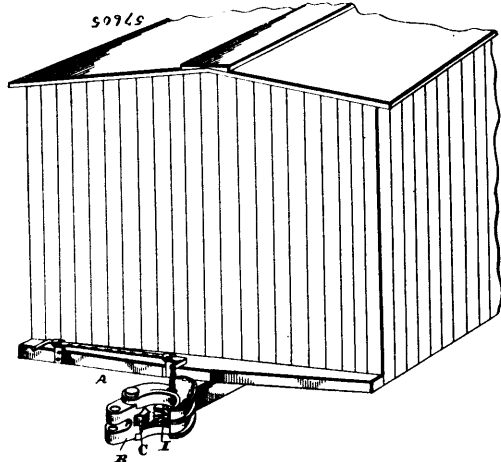

John C. Taylor, Findlay, Ohio, U.S.A., 23th September, 1897; 6 years. (Filed 17th September, 1897.)

*Claim.*—1st. In a car-coupling, the combination of a draw-head, a horizontally-swinging jaw, a locking-box situated wholly within the draw-head, the forward end of the block having a reciprocating movement on the bottom of the draw-head, the rear end of the block being cut away and provided with an inclined slot extending horizontally therethrough, a pin extending transversely through the draw-head at a point above the bottom of the draw-head, to permit the rear end of the locking-block to move downward as it moves forward with the said draw-head, and an operating means extending through the draw-head therinto and operatively connected with the said block for moving it backward within the draw-head, substantially as shown and described. 2nd. The combination with the draw-head, the pivoted jaw, situated in the rear portion of the draw-head, and the detent slidable longitudinally in the draw-head and adapted to move upon the cleat and abut against the abutment, substantially as shown and described. 3rd. The combination of the draw-head, the pivoted jaw having its tail portion provided with flange D, the sliding detent provided with a depression upon its forward end, where it is engaged by flange D, as described, substantially as shown and described. 4th. The combination of the draw-head, the pivoted jaw, the pivot-pin, the sliding detent having the inclined slot, whereby it is adapted to move back and forth upon the pin, the friction-roller carried by the forward end of the detent, and the side flanges or guides K, and L, upon the draw-head for holding the detent from lateral displacement, substantially as shown and described.

**No. 57,606. Electric Meter. (Compteur électrique.)**

The Canadian General Electric Company, Toronto, Ontario, Canada, assignee of Charles P. Steinmetz, Schenectady, New York, U.S.A., 28th September, 1897; 6 years. (Filed 21st May, 1896.)

*Claim.*—1st. An electric meter for monocyclic circuits, comprising separate field coils whose exciting currents are respectively maintained equal or proportional to the currents in the main or teaser circuits, and separate armatures, one coupled directly or inductively across the main power leads, and the other between the teaser wire and a neutral point dividing the voltage in the main circuit. 2nd. A meter for monocyclic circuits, comprising recording and

braking mechanism, and two armatures on the same shaft or geared together, one in circuit across the main power leads with an appro-

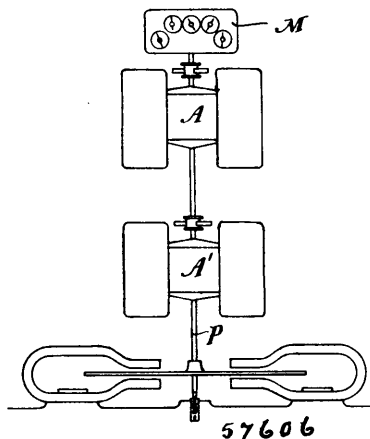

prate resistance, and the other in circuit between the teaser wire and a neutral point dividing the voltage in the main circuit, field coils for the two armatures, and means for maintaining the excitation of the field coils proportional respectively to the current flowing in the main and teaser circuits. 3rd. An electric meter for monocyclic circuit, comprising field coils and an armature connected electrically or inductively, the one in series with the other across the main circuit leads, a separate shunt across the main leads affording a neutral point where the voltage is divided equally, and a second armature and field coil connected respectively in the circuit of the teaser wire and between the teaser wire and the neutral point, as set forth.

**No. 57,607. System of Electrical Distribution. (Système de distribution électrique.)**

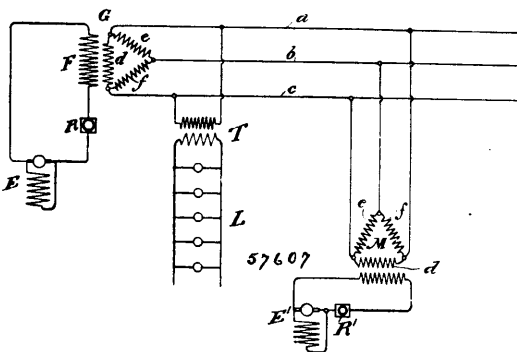

The Canadian General Electric Co., Toronto, Ontario, Canada, assignee of Charles P. Steinmetz, Schenectady, New York, U.S.A., 28th September, 1897; 6 years. (Filed 21st May, 1897.)

*Claim.*—1st. The method of electrical distribution, which consists in supplying from a polyphase generator, or supply source, alternating currents of a given phase relation for operating lights coupled in one of the branches into which the system is divided, and alternating currents of different phase relation for operating motors connected to one or more other branches of the system, and transferring energy between the lighting and motor branches through a balance wire to preserve the proper distribution of load, as set forth. 2nd. The method of electrical distribution, which consists in dividing the load on the different branches of the system between lamps and motors, the lamps forming the principal load on one branch, and the motors the principal load on the other, and transferring energy between the motor and lighting branches through a coil on the motors connected across the lighting branch, and generating an electromotive force counter to the impressed electromotive force on the lighting branch, as set forth. 3rd. The method of electrical distribution, which consists in massing the lamps, or like purely single-phase translating devices, on one branch of a polyphase system, deriving the principal energy for operating motors or motive apparatus from the remaining branch or branches of the system, and transferring energy between the lighting and motor branches by a balance wire, in which the direction and amount of energy so transferred, is dependent upon the relation between the impressed electromotive force on the lighting circuit and the counter electromotive force generated in a motor coil connected across the lighting mains, as set forth. 4th. The herein described system of electrical distribution, comprising a

polyphase generator and distributing mains, a lighting circuit or circuits, so connected as to form the principal load on one branch of the system, a motor or motors having coils connected across one or more other branches of the system, and forming the principal load thereon, and an out-of-phase motor coil connected across the lighting branch through which energy is transferred between the motor and lighting branches, for the purpose set forth. 5th. An electrical distribution system, comprising in combination a lighting circuit fed with alternating currents of given phase relation from one branch of a polyphase circuit, and motors of the monocyclic type provided with a main coil receiving power current from a second branch of the distributing system, and a supplementary or teaser coil connected across the mains of the lighting branch whereby the main operating energy for the lights and motors respectively, is derived from different branches of the system, but the transfer of energy from one to the other is rendered possible, in the manner described.

**No. 57,608. Fire Escape. (Sauveteur d'incendie.)**



William B. Wilson, Aberdeen, Washington, U.S.A., 28th September, 1897; 6 years. (Filed 13th September, 1897.)

*Claim.*—1st. In a fire escape of the kind described, the friction levers pivotally connected at their upper ends, and corrugated near said ends as described, and the supporting strap or band connected to the lower ends of said levers, substantially as shown and described. 2nd. In a fire escape of the kind described, the combination with the friction levers pivotally connected at their upper ends and corrugated near the said ends, said levers curving away from each other at their lower ends, the supporting strap connected to the said lower ends, and a regulating lever for separating said friction levers, substantially as shown and described. 3rd. In a fire escape of the kind described, the combination with the friction levers pivotally connected at their upper ends, the bearing plates integral with one of the said levers and between which the opposite lever is pivoted, and the supporting strap connected to the lower ends of the friction levers, substantially as described. 4th. In a fire escape of the kind described, a friction lever having the bearing plates integral therewith, the opposing friction lever pivoted between the bearing plates, said friction levers curving away from each other at their lower ends, the supporting strap attached to said lower ends, and the regulating lever pivoted upon the exterior of the bearing plates and adapted to operate upon the pivoted friction lever, substantially as described. 5th. In a fire escape of the kind described, the combination with a friction lever having the bearing plates formed integral therewith, the upper portion of said lever being corrugated and grooved as described, of the opposite friction lever pivoted between the bearing plates and having the upper portion corrugated or grooved, said friction levers curving outwardly away from each other at their lower ends, and provided with hooks at said ends, the supporting strap having loops at each end adapted to engage the hooks, the bifurcated regulating lever pivoted upon the exterior of the bearing plates and having a pin adapted to engage the pivoted friction levers, substantially as shown and described.

**No. 57,609. Bran Packer. (Emballeur de son.)**

Ballard & Ballard Company, assignee of John Koelner, both of Louisville, Kentucky, U.S.A., 28th September, 1897; 6 years. (Filed 13th September, 1897.)

*Claim.*—1st. A machine for packing the products of grain and other materials into angular packages by the use of a round auger,

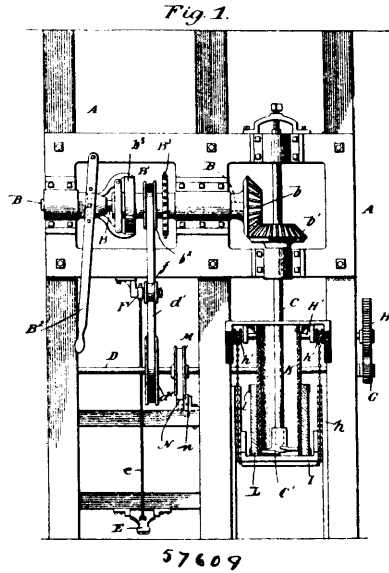

comprising a vertically movable platform and means for raising the same and permitting it to descend with a yielding resistance against applied pressure, a jacket or casing mounted on said platform having a polygonal opening therethrough, a polygonal stationary casing arranged over said jacket adapted to fit the interior thereof and having a cylindrical opening therethrough, a packing auger working in said opening, and means for rotating the auger, whereby a square or polygonal package may be formed by the action of a round feeding and forcing device adapted to force the material from a cylindrical into a polygonal opening containing the sack to be filled, substantially as described. 2nd. In a machine for packing the products of grain and other materials, a vertically disposed shaft carrying a packing auger, a stationary tube in which said auger works, a vertically movable platform arranged below said cylinder, means for permitting said platform to descend with a yielding resistance opposing the pressure of the auger on the material that is being packed, mechanism for elevating the platform, and a casing or jacket on said platform having its interior shaped to conform to the exterior of said tube and arranged to make telescopic connection therewith; said platform being suspended by connections between the same and the elevating mechanism arranged in substantially the same vertical plane with the auger shaft or axis of the auger, so that the resistance to the pressure of the packing auger shall be exerted centrally thereof, substantially as described. 3rd. In a machine for packing the products of grain and other materials, a vertically disposed shaft carrying a packing auger, a stationary tube in which said auger works having its interior angular in cross-section, a vertically movable platform arranged below said cylinder, means for permitting said platform to descend with a yielding resistance opposing the pressure of the auger on the material that is being packed, mechanism for elevating the platform having its interior shaped to conform to the exterior of said tube and arranged to make telescopic connection therewith, said platform being suspended by flexible connections between the same and the elevating mechanism arranged in substantially the same vertical plane with the auger shaft or axis of the auger, so that the resistance to the pressure of the packing auger shall be exerted centrally thereof, substantially as described. 4th. In a machine for packing the products of grain and other materials, a round packing auger combined with a cylindrical enclosure in which the auger works having an exterior casing made square or polygonal in cross-section to receive the sack to be packed, together with a jacket having an angular opening therethrough corresponding in shape with said exterior casing and adapted to fit over the sack stretched on said casing, said jacket being mounted on a vertically movable platform suspended by flexible connections arranged centrally below the axis of rotation of the auger, and means for raising the platform and yieldingly resisting its downward movement caused by the pressure of the auger on the material that is being packed, substantially as described. 5th. In a machine for packing the products of grain and other materials, the jacket or casing for the stationary tube in which the packing auger works, comprising a series of concave metallic sections hinged together in cylindrical form, the said sections enclosing a series of independent wooden sections each of segmental form and arranged within the metallic sections so as to form a polygonal opening through the jacket when the sections thereof are closed, and means for locking the sections in a closed position, substantially as described.

No. 57,610. Packing Auger.

(Tarière pour emballage.)

Fig. 1.

Fig. 4.

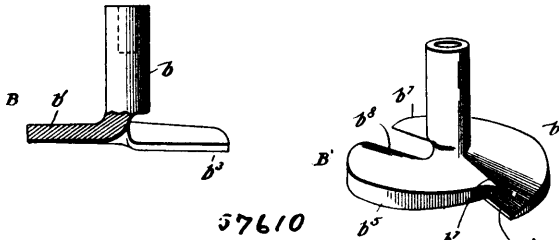

Ballard & Ballard Company, assignee of John Koelner, both of Louisville, Kentucky, U.S.A. 28th September, 1897; 6 years. (Filed the 13th September, 1897.)

Claim.—1st. A packing auger for the products of grain and other material, comprising a rotary blade or flange extending outwardly from a stem or shaft, and having a heel and toe portion slightly separated from each other and extending inwardly from the circumference of the flange to substantially the vertical axis thereof, so as to adapt the same to receive and discharge the material at the side of the axis on which said opening is located in a sheet of a width substantially equal to the distance from the centre to the circumference of the flange; the latter being gradually inclined and having a smooth lower surface from its toe to its heel, whereby the material may be equally distributed and packed without injury thereto, substantially as described. 2nd. A packing auger for the products of grain and other material, comprising a shank or stem adapted to be secured to a rotatable shaft, and a spiral flange extending outwardly from said shank, and having a discharge opening extending from the periphery of the flange to substantially the vertical axis thereof, said flange forming an inclined plane or surface which is smooth on the underside thereof from the highest point of the toe to the heel or discharge, whereby the material may be equally distributed and packed without injury thereto, substantially as described. 3rd. A packing auger for the products of grain and other material, comprising a shank or stem adapted to be secured to a rotatable shaft, and a substantially disc-shaped feeding device on the lower portion of said shank, consisting of a single spiral blade or flange forming a gradually inclined plane and provided with an engaging lip or toe and a heel beneath said toe extending from the circumference of the flange to substantially its vertical axis, so as to form a discharge opening which also extends from the circumference of the flange to substantially the vertical axis thereof, said blade being smooth on the underside thereof from its toe to its heel, whereby the material may be equally distributed and packed without injury thereto, substantially as described.

No. 57,611. Brake Shoe. (Sabot de frein.)

Fig. 1

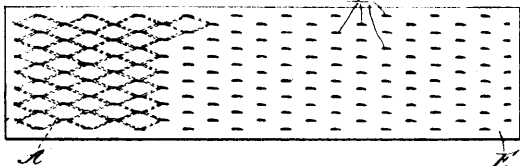
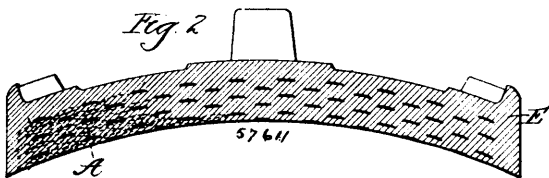

Fig. 2



The International Brake Shoe Company, assignee of William Durham Sargent, both of Chicago, Illinois, U.S.A., 28th September, 1897; 6 years. (Filed the 2nd August, 1897.)

Claim.—1st. A brake shoe composed partly of metal having superior braking qualities, such as cast metal, and partly of ductile metal possessing great longevity, the ductile metal being distributed throughout the body of the shoe in differing planes to provide a wearing face for the shoe of a finely divided and composite character. 2nd. A brake shoe composed of two different kinds of metal disposed in differing planes and so combined as to provide a wearing face for the shoe of a finely divided and composite character and

which is constantly changing, whereby the relative disposition of the two metals on the wearing face constantly changes as the shoe wears. 3rd. A brake shoe composed of two different kinds of metal, one of which is disposed in differing planes and constantly changes in position on the wearing face of the shoe, said metals being so combined as to provide a wearing face for the shoe of a finely divided and composite character. 4th. A brake shoe composed of two different kinds of metal, one of which is disposed in differing planes and constantly changes in area on its wearing face, said metals being so combined as to provide a wearing face for the shoe of a finely divided and composite character. 5th. A brake shoe composed of two different kinds of metal, one of which is disposed in differing planes and constantly changes in area and position on its wearing face, to provide a wearing face of a finely divided and composite character. 6th. A cast metal brake shoe, having an insert consisting of a forminous ductile metal body and constituting a part of the wearing face of the shoe. 7th. A cast metal brake shoe, having a forminous ductile metal insert constituting a part of the wearing face of the shoe, said insert being permeated in different directions by the cast metal so as to form a solid homogeneous mass. 8th. A cast metal brake shoe, having an insert composed of a number of forminous sections of ductile metal. 9th. A cast metal brake shoe, having an insert composed of a laminated pile of forminous sections of ductile metal. 10th. A cast metal brake shoe, having an insert composed of expanded metal. 11th. A cast metal brake shoe, having an insert composed of a laminated pile of sections of expanded metal. 12th. A cast metal brake shoe, having an insert composed of a laminated pile of forminous sections, said sections being arranged with relation to each other so that the holes therein will not register. 13th. A cast metal brake shoe having a forminous sinuous reinforcement embedded therein, substantially as and for the purpose described.

No. 57,612. Hose Coupler. (Joint de boyauc.)

FIG. 1.

FIG. 2.

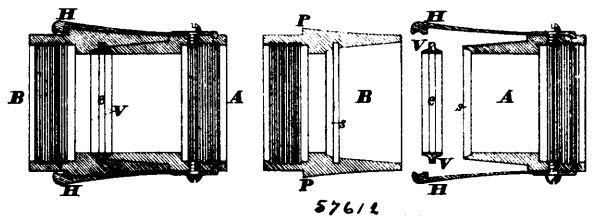

John Foulds Redford Downie, Perth, and William Gordon, Stratford, both in Ontario, Canada, 28th September, 1897; 6 years. (Filed 20th May, 1897.)

Claim.—1st. The hooks H H, employed in connection with the projection P, substantially as set forth. 2nd. The automatic annular valve V, employed in connection with the annular seat s, as shown and set forth. 3rd. The bifurcate key, fig. 4, all substantially as and for the purposes described and shown.

No. 57,613. Apparatus to Prevent Horses from Running Away. (Appareil pour empêcher les chevaux de prendre le mors aux dents.)

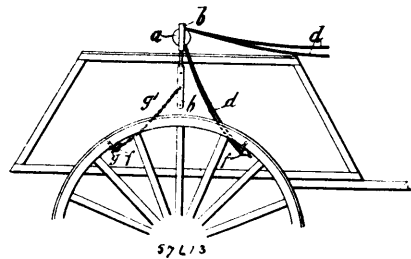

Henry William Doggett and James McChesney, both of Wellington, New Zealand, 28th September, 1897; 6 years. (Filed 18th September, 1897.)

Claim.—1st. A checking apparatus consisting of a roller suitably mounted on the vehicle within convenient reach of the driver and a hook or hooks fixed to the wheel, substantially as and for the purposes set forth herein. 2nd. A checking apparatus to prevent horses from running away, constructed, arranged, and operating substantially as and for the purposes hereinbefore set forth.

No. 57,614. Brake Adjuster. (Engrenage de frein.)

Frederick William Selley, Enmore, and William Holmes Nisbet, Martin Place, Sydney, both in New South Wales, 28th September, 1897; 6 years. (Filed 20th September, 1897.)

Claim.—1st. In brake gears of railway rolling stock, the combination of an arrangement with a brake truss or beam and an actuating or brake lever fulcrumed in a suspension link, of a nut box or bridle or

support for a screw connection between the pull rod of said brake truss or beam and said nut box or bridle or support articulated to

tially as and for the purposes described. 2nd. In an ash-sifter, adapted to be mounted on circular receptacles of different diameters,

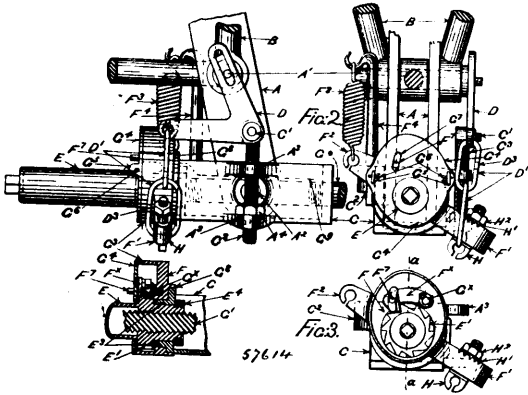

said lever, a rocking pawl resiliently anchored to a rigid support and adapted by means of a ratchet to revolve one factor of said screw connection and levers, cranks, arms or links or chains or ropes and pulleys connecting said lever to said rocking pawl, so that upon the applying and releasing of the brakes the alterations of the relative positions or angular set of said lever and the said articulated nut box bridle or holder will cause said pawl and ratchet by partially revolving the one factor of the screw connection to shorten the length of the pull rod of the said brake truss or beam, substantially as herein described and explained. 2nd. The particular combination and arrangement of mechanical parts all together forming an improved slack adjuster for brake gears substantially as herein described and explained and as illustrated in figures 2A, 3A and 4A of the drawings. 3rd. The particular combination and arrangement of mechanical parts altogether forming an improved slack adjuster for brake gears substantially as herein described and explained and as illustrated in figures 5A and 6A of the drawings. 4th. The particular combination and arrangement of mechanical parts altogether forming an improved slack adjuster for brake gears substantially as herein described and explained and as illustrated in figures 1 to 6 of the drawings. 5th. The particular combination and arrangement of mechanical parts altogether forming an improved slack adjuster for brake gears substantially as herein described and explained and as illustrated in figures 7, 8 and 9 of the drawings. 6th. The particular combination and arrangement of mechanical parts altogether forming an improved slack adjuster for brake gears substantially as herein described and explained and as illustrated in figures 10 and 11 of the drawings. 7th. In brake gear slack adjusters of the class set forth, a pawl actuating rocking lever containing or made integral with a pawl cover or box substantially as herein described and explained and as illustrated in the drawings. 8th. In brake gear slack adjusters of the class set forth the particular combination and arrangement with the nut box or bridle of the rocking lever, the pawl and the ratchet nut for the purposes and in the manner substantially as herein described and explained and as illustrated in the drawings, and more particularly in figure 4 thereof. 9th. In brake gear slack adjusters of the class set forth, an adjustable pivot or fulcrum for the bell crank or actuating lever for the purposes set forth substantially as herein described and explained and as illustrated in the drawings. 10th. In brake gear slack adjusters of the class set forth, an adjustable attachment or rocking lever connection for the purposes set forth substantially as herein described and explained and as illustrated in the drawings. 11th. In brake gear slack adjusters of the class set forth, the combination with a pawl box and its cover, of a handle or pin on the pawl protruding through said cover for the purposes set forth substantially as herein described and explained and as illustrated in the drawings. 12th. In brake gear slack adjusters of the class set forth, a pull rod articulated to a triangular brake beam or truss for the purposes set forth substantially as herein described and explained and as illustrated in the drawings. 13th. In brake gear slack adjusters of the class set forth, the combination and arrangement with the pull rod having a knuckle joint and of a yoke taking over or around the bight of the brake beam or truss and being fastened thereto substantially as herein described and explained and as illustrated in the drawings.

**No. 57,615. Ash Sifter. (Crible à cendres.)**

Adolph Haenichen, Paterson, New Jersey, U.S.A., 28th September, 1897; 6 years. (Filed 20th September, 1897.)

*Claim.*—1st. In an ash-sifter, adapted to be mounted on circular receptacles of different diameters, the combination with a rotary sifter, of a supporting-plate provided with a central rectangular opening, a series of curved lugs concentrically and alternately arranged in circles of different radii and projecting downward from said supporting-plate, and a rectangular-shaped box upwardly projecting from said plate and surrounding the central opening therein and suitably supporting said rotary sifter, all said parts substan-

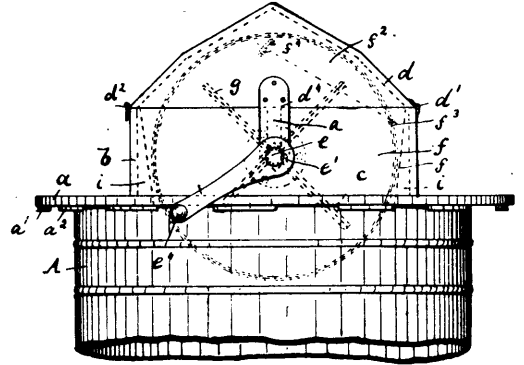

the combination with the supporting-plate provided with a central rectangular opening, a series of curved lugs concentrically and alternately arranged in circles of different radii and projecting downward from said supporting-plate, a rectangular box upwardly projecting from said supporting-plate and surrounding the central opening therein, and a rotary sifter suitably supported in said box and projecting into and through the central opening of the supporting-plate, all said parts substantially as and for the purposes described. 3rd. In an ash-sifter, adapted to be mounted on circular receptacles of different diameters, the combination with the supporting-plate provided with a central rectangular opening, of a rectangular box upwardly projecting from said supporting-plate and surrounding the central opening therein, an inclined block in each corner of the rectangular box and adapted to close the openings formed between the sides of the central opening in the supporting-plate and the outer periphery of the receptacle on which said supporting-plate is placed, and a rotary sifter suitably mounted in said rectangular box and projecting into and through the central opening of the supporting-plate, substantially as and for the purposes described. 4th. In an ash-sifter, adapted to be mounted on circular receptacles of different diameters, the combination with the supporting-plate provided with a central rectangular opening, of a rectangular box projecting upwardly from said supporting-plate and surrounding the central opening therein and provided at opposite sides with vertical elongated slots, a shaft removably arranged in said slots, a cylindrical sifter mounted on said shaft and projecting into and through the central opening of the supporting-plate, and an inclined block in each corner of the rectangular box and adapted to close the openings formed between the sides of the central opening in the supporting-plate and the outer periphery of the receptacle on which said supporting-plate is placed, all said parts substantially as and for the purposes described.

**No. 57,616. Rock and Like Drill. (Foret, etc.)**

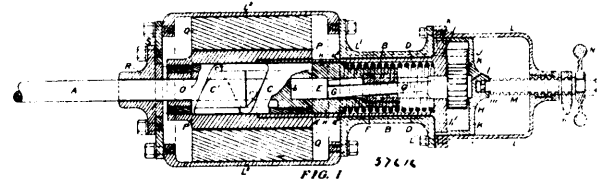

Sydney Pratt Blackmore, R. O. Gardner Drummond, and E. J. Way, all of Johannesburg, South African Republic, 28th September, 1897; 6 years. (Filed 7th September, 1897.)

*Claim.*—1st. In driving mechanism for rock and like drills, a cylindrical case, or cylindrical piece formed with a spiral or approximately spiral cam or screw surface attached to, connected with or engaging the driving part of the drill and a corresponding cylindrical cam or cylindrical piece formed with a spiral or approximately spiral cam or screw surface attached to, connected with or engaging the driven part of the drill, with which the cylindrical cam attached to the driving part of the drill gears or engages, for converting the rotary motion of the former into the reciprocating motion of the latter, substantially as described. 2nd. In driving mechanism for rock and like drills, a cylindrical cam or hollow cylindrical piece formed with a spiral or approximately spiral cam or single pitch screw thread or surface mounted concentrically on the shaft attached to or connected with the driving part of the drill and a corresponding cylindrical cam or hollow cylindrical piece formed with a spiral or approximately spiral cam or single pitch screw thread or surface mounted concentrically on and attached to the drill shaft, with which the cylindrical cam attached to the driving part of the drill gears or engages for converting the rotary motion of the driving part into the reciprocating motion of the driven part, substantial y

as described. 3rd. In driving mechanism for rock and like drills, a cylindrical cam or hollow cylindrical piece formed with a spiral or approximately spiral cam or single pitch screw thread or surface mounted concentrically on the drill shaft attached to or connected with the driving part of the drill, a corresponding cylindrical cam or hollow cylindrical piece formed with a spiral or approximately spiral cam or single pitch screw thread or surface mounted concentrically on and attached to the drill shaft with which the cylindrical cam attached to the driving part of the drill gears or engages for converting the rotary motion of the driving part into the reciprocating motion of the driven part, and an adjustable spring for imparting the percussive forward motion to the drill bit through the drill shaft immediately the cams have reached their limit of stroke or maximum point of expansion, substantially as described. 4th. In rock and like drills, the combination of the drill shaft A, the concentric cylindrical cam C attached thereto, the cylindrical cam C<sup>1</sup> mounted concentrically on drill shaft A, and attached to the driving mechanism of the drill, gearing or engaging cam C for converting the rotary motion thereof into the reciprocating motion of cam C<sup>1</sup>, the adjustable spring D for imparting the percussive motion to the drill bit through the medium of the drill shaft A immediately the cams have reached their limit of stroke or maximum point of expansion, and means for imparting the rotary motion to the drill shaft in addition to the reciprocating motion imparted by the cams, substantially as described. 5th. In rock drills and the like, the combination of the drill shaft A, the concentric cylindrical cam C attached thereto, the corresponding cylindrical cam C<sup>1</sup> attached to the rotor P of the electric motor P, Q, the rotor P and the stator Q comprising the electric motor, mounted concentrically on the drill shaft A, an adjustable spring for imparting the percussive motion to the drill shaft immediately the cams have reached their limit of stroke, and means for imparting the rotary motion to the drill shaft, in addition to the reciprocating motion, substantially as described. 6th. In combination, the drill shaft A, the boss a formed thereon and forming the shoulders a<sup>1</sup> a<sup>2</sup>, the cylindrical cam C screwed on to the shaft A up to the shoulder a<sup>1</sup>, the corresponding cylindrical cam C<sup>1</sup> screwed within the rotor P, the bush O screwed within the cam C<sup>1</sup> and forming the bearing for the rotating part of the motor, the rotor P and the stator Q, comprising the electric motor mounted concentrically on the drill shaft A, the spiral spring D inserted within the cylindrical casing B and bearing against the shoulder a<sup>2</sup> formed on the drill shaft, the cylindrical casing B and its cover b<sup>1</sup>, against which the spring D bears, the cavity E formed in the inner extremity of the drill shaft A, the ratchet nut F screwed therein, the ratchet bar G passing through the ratchet nut and projecting into the cavity E, the ratchet or leaf wheel H attached to the end of the ratchet bar G, the pawl J, the cup-shaped piece K attached to the cover b<sup>1</sup> of the cylindrical casing B for regulating the tension of spring D, the adjusting screw M fitted with a locking device, operating handle N, and the several parts L, L<sup>1</sup>, L<sup>2</sup>, annular piece S and cap R of the exterior casing, substantially as described and shown. 7th. In rock drills and the like, the combination of the drill shaft A, the concentric cylindrical cam C attached thereto, the corresponding cylindrical cam C<sup>1</sup>, gearing therewith attached to the extension piece or continuation T, of the hollow armature or rotor shaft U of the motor, the rotor P and stator Q mounted concentrically on the drill shaft A, the rotor shaft U and the extension T thereof, the packing ring, and an adjustable spring for imparting the percussive motion to the drill bit through the drill shaft when the cams C, C<sup>1</sup>, have reached their limit of stroke, and means for imparting the rotary motion to the drill shaft in addition to the reciprocating motion transmitted through the cams, substantially as described. 8th. In combination, the drill shaft A, the boss a formed thereon and forming the shoulders a<sup>1</sup>, a<sup>2</sup>, the cylindrical cam C screwed on to the shaft A up to the shoulder a<sup>1</sup>, the corresponding cylindrical cam C<sup>1</sup>, gearing therewith attached to the extension piece or continuation of the hollow armature or rotor shaft U of the motor, the rotor P and the stator Q mounted concentrically to the drill shaft A, the rotor shaft U and the extension T thereof, the packing ring V, the spiral spring D inserted within the cylindrical casing B and bearing against the shoulder a<sup>2</sup> formed on the drill shaft, the cylindrical casing B and its cover b<sup>1</sup>, against which the spring D bears, the cavity E formed in the inner extremity of the drill shaft A, the ratchet nut F screwed therein, the ratchet bar G passing through the ratchet nut and projecting into the cavity E, the ratchet or leaf wheel H attached to the end of the ratchet bar G, the pawl J, the cup-shaped piece K attached to the cover b<sup>1</sup> of the cylindrical casing B for regulating the tension of spring D, the adjusting screw N fitted with a locking device, operating handle N, and the several parts L, L<sup>1</sup>, L<sup>2</sup>, of the casing of the drill, substantially as described.

**No. 57,617. Window Sash and Frames.**  
(*Cadre de fenêtre et de châssis.*)

Kendall's Patent Reversible Window Sash Co., Birmingham, assignee of Edmund George Kendall, Harborne, Stafford, both in England, 28th September, 1897; 6 years. (Filed 9th September, 1897.)

*Claim.*—1st. In window frames capable of turning upon a pivot, a T-shaped slotted plate for the point to work in, and a key for keeping the pivot in position, in the manner substantially as herein-

before described, and as shown upon the accompanying sheet of drawings. 2nd. In window frames capable of turning upon a

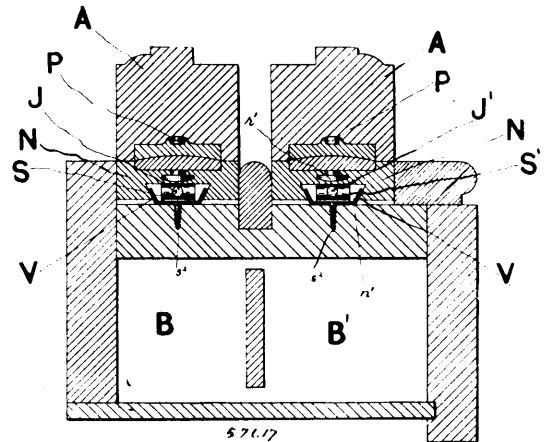

pivot, a double acting spring fixed at its centre in a dovetail groove formed in a slide pivoted to the sash stile and working in a metal channel or its equivalent in the manner and for the purpose substantially as hereinbefore described, and as shown upon the accompanying sheet of drawings. 3rd. In pivoted sliding window frames, the combination of the curved wooden slide with the hollowed stile to correspond and the dovetail channel piece or its equivalent kept tight by the spring substantially as hereinbefore described, and as shown upon the accompanying sheet of drawings. 4th. In pivoted sliding window frames, the combination of the curved wooden slide with the hollowed stile to correspond, the dovetailed channel piece or its equivalent kept tight by the spring and the slotted plate for the pivot to work in with its key for keeping the pivot in position, substantially as hereinbefore described and shown.

**No. 57,618. Disk Harrow. (Herse à disque.)**

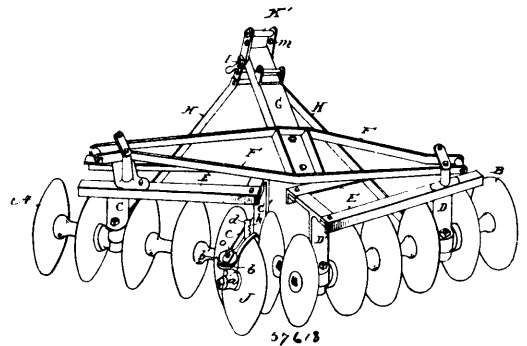

The Ohio Cultivator Co., assignee of Moses W. Konus, both of Bellcone, Ohio, U.S.A., 28th September, 1897; 6 years. (Filed 16th September, 1897.)

*Claim.*—1st. In a disk harrow in which the inner ends of the gangs are arranged one in advance of the other, the combination with the foremost one of said gangs, of an auxiliary disk mounted on said foremost gang and projected in the rear thereof, the position of said disk being essentially in the rear of the space between the two extreme inner disks of said foremost gang, substantially as and for the purpose specified. 2nd. In a disk harrow in which the gangs are placed one in advance of the other, the combination with the foremost gang, of an auxiliary disk projected in the rear of said foremost gang and in line with the space between the two extreme inner disks of said gang, an arm upon which said auxiliary disk is mounted, the said arm being provided with a longitudinal slot on its inner end, and a ratchet-plate engaging with similar means on the inner standard of said foremost gang, whereby both a horizontal adjustment from or toward said gang, and a vertical adjustment of said auxiliary disk may be obtained, substantially as described.

**No. 57,619. Elbow for Piping. (Coudre de tuyaux.)**

Carl L. Laubsch and Oscar E. Uhle, both of Norfolk, Nebraska, U.S.A., 28th September, 1897; 6 years. (Filed 18th September, 1897.)

*Claim.*—1st. A pipe-section or elbow, comprising a series of independent sections, each pivoted to the next adjacent section so as to

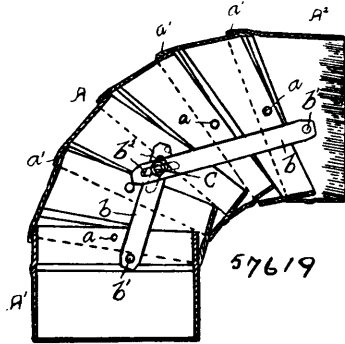

be independently adjusted, and means for holding the sections in an adjusted position, whereby the elbow or pipe-section may be caused

to assume various angles or degrees of curvature, substantially as described. 2nd. In an elbow or pipe-section, the combination with a series of independent sections pivotally secured together, of a pair of levers or straps arranged within the elbow and pivoted at one of their ends to the sections and provided with slots in their other ends, a bolt for engaging the slots in the straps, and means for tightening the bolt so as to clamp the sections and straps, whereby the elbow or pipe-section may be adjusted and held at various angles or degrees of curvature, substantially as described. 3rd. In an elbow or pipe-section, the combination with a series of independent overlapping sections pivotally held together so as to be independently adjusted, each overlapping section being provided with an offset upon its upper surface to permit the overlapping section to slide readily over next succeeding section, a pair of levers or straps arranged within the elbow having one of their ends pivoted to the end sections and their other inner ends provided with slots and extending inwardly so as to overlap, a bolt passing through one of the sections and engaging the slots in the straps, and means for tightening the bolt so as to clamp the sections and straps, whereby the elbow or pipe-sections may be adjusted and held at various angles or degrees of curvature, substantially as described.





## TRADE-MARKS

Registered during the month of September, 1897, at the Department of Agriculture--  
Copyright and Trade-Mark Branch.

6162. NORTH AMERICAN CHEMICAL COMPANY, LIMITED, Goderich, Ont. Salt, 1st September, 1897.
6163. THE STARR MANUFACTURING COMPANY, LIMITED, Dartmouth, N.S. Skates, 3rd September, 1897.
6164. THOMAS L. WILLSON, St. Catharines, Ont. Carbide of Calcium, 7th September, 1897.
6165. } WILLIAM PATON, of Johnstone, near Glasgow, Scotland. Boot and Shoe  
6166. } Laces, 7th September, 1897.
6167. THE MUSCATINE OAT MEAL COMPANY, Muscatine, Iowa, U.S.A. Rolled Oats and Oat Meal, 8th September, 1897.
6168. CLAYOQUOT FISHING & TRADING COMPANY, LIMITED, Clayoquot, B.C. Canned Salmon, 8th September, 1897.
6169. L. GNAEDINGER, SON & COMPANY, Montreal, Que. Furs, Hats and Caps, 8th September, 1897.
6170. CALIFORNIA FIG SYRUP COMPANY, Rena, Nevada, U.S.A. Proprietary Medicine, 8th September, 1897.
6171. THE G. F. HARVEY COMPANY, Saratoga Springs, N.Y., U.S.A. Anodyne and Antifebrile Medicinal Preparations, 9th September, 1897.
6172. } WILLIAM PATON, of Johnstone, near Glasgow, Scotland. Boot and Shoe  
6173. } Laces, 10th September, 1897.
6174. FINLAY, SMITH & COMPANY, Montreal, Que. Cloth, Wool Fabrics and Worsted Fabrics, 10th September, 1897.
6175. EDMUND JAMES MILLS, 60 John Street, Glasgow, Scotland. Liquid Glue, 10th September, 1897.
6176. ONTARIO PACKING COMPANY, New Westminster, B.C. Canned Salmon, 14th September, 1897.
6177. THE FARBENFABRIKEN vormals FRIEDRICH BAYER & COMPANY, Elberfeld, in the Kingdom of Prussia, in the Empire of Germany. A Toilet Preparation, 14th September, 1897.
6178. THE FARBENFABRIKEN vormals FRIEDRICH BAYER & COMPANY, Elberfeld, in the Kingdom of Prussia, in the Empire of Germany. Dye Stuffs, 14th September, 1897.
6179. THE FARBENFABRIKEN vormals FRIEDRICH BAYER & COMPANY, Elberfeld, in the Kingdom of Prussia, in the Empire of Germany. Pharmaceutical Preparations, 14th September, 1897.
6180. MUSCATINE OAT MEAL COMPANY, Muscatine, Iowa, U.S.A. Rolled Oats and Oat Meal, 14th September, 1897.
6181. CHARLES WILLIAM CORNISH, Selkirk, Manitoba. Stove Pipe Varnish, 14th September, 1897.
6182. THE BICKMORE GALL CURE COMPANY, Old Town, Maine, U.S.A. A Salve and other Medical Compounds, 14th September, 1897.
6183. } J. & J. COLMAN, LIMITED, Carrow Works, Norwich, and 108 Cannon  
6184. } Street, London, England. Blue for Laundry Purposes, 14th  
6185. } September, 1897.
6186. } J. & J. COLMAN, LIMITED, Carrow Works, Norwich, and 108 Cannon  
6187. } Street, London, England. Starch for Laundry Purposes, 14th  
6188. } September, 1897.  
6189. }
6190. THOMAS KENNY, Sarnia, Ont. Tea, 16th September, 1897.
6191. SIGISMUND KUTNOW, London, England. Proprietary Medicines, Mineral Salts and Waters, both Natural and Artificial and preparations therefrom, beverages and chemical substances prescribed for use in medicine and pharmacy, 16th September, 1897.
6192. SIGISMUND KUTNOW, London, England. Medicinal Preparations, and more particularly Medicinal Powders and Cigarettes that are to be burned and the fumes thereof inhaled, 16th September, 1897.

6193. D. PERRIN & COMPANY, London, Ont. Biscuits, Candies and Confectionery, 17th September, 1897.
6194. M. H. GOOLD & COMPANY, 9 and 11 Oriel Street, Liverpool, England. Lubricating, Heating and Lighting Oils, Lubricating Greases and Creams, and other similar lubricants, 18th September, 1897.
6195. ROBERT M. CURRIE, Westham Island, B.C. Canned Salmon, 18th September, 1897.
6196. SCOTT & BOWNE, New York, N.Y., U.S.A. Medicines, 20th September, 1897.
6197. TAYLOR SCOTT & COMPANY, Toronto, Ont. Woodenware, 21st September, 1897.
6198. THE BELL ORGAN & PIANO COMPANY, LIMITED, Guelph, Ont. Reed Organs and Organ Actions, 21st September, 1897.
6199. R. A. LISTER & COMPANY, LIMITED, Dursley, England. Butter, Cheese and Bacon, 23rd September, 1897.
6200. JOHN WOOD, 5 Kilvert's Buildings, Withy Grove, Manchester, England. Dog, Poultry and other Animal Foods, Dog Kennels, Poultry Runs, and every description of appliance in animal and aviary culture, 24th September, 1897.
6201. JULES GIRARDIN, Brockville, Ont. Cigars, 27th September, 1897.
6202. C. B. McALLISTER, Peterborough, Ont. Flour, 29th September, 1897.
6203. PRICE BROTHERS & COMPANY, Quebec, Que. Timber or Lumber of any kind, 29th September, 1897.
6204. McPHERSON & HICKEY, Vancouver, B.C. Canned Salmon, 30th September, 1897.

# COPYRIGHTS

Entered during the month of September, 1897, at the Department of Agriculture—  
Copyright and Trade-Mark Branch.

9439. INDEX TO INCORPORATED BODIES AND TO PRIVATE AND LOCAL LAW UNDER DOMINION, AND MANITOBA, ONTARIO AND QUEBEC STATUTES, PROCLAMATIONS AND LETTERS PATENT. FROM 17 GEO. III. (1777) TO 1st JANUARY, 1896. By Ph. Baudouin, Montreal, Que., 1st September, 1897.
9440. KLONDYKE LANCERS. By J. Stanton Gladwin. The Anglo-Canadian Music Publishers' Association (Ltd.), London, England, 2nd September, 1897.
9441. THE MINERAL WEALTH OF CANADA. (A Guide for Students of Economic Geology.) By Arthur B. Willmott, M.A., B.Sc. Wm. Briggs, (Book-Steward of the Methodist Book and Publishing House), Toronto, Ont., 4th September, 1897.
9442. DOLLY'S LULLABY. Words by Frank R. Horsky. Music by W. A. Norman. Whaley, Royce & Co., Toronto, Ont., 7th September, 1897.
9443. MY LITTLE SWEETHEART GRACE. Words by Phil. A. Kilfoil. Music by Will. Hauer. Whaley, Royce & Co., Toronto, Ont., 7th September, 1897.
9444. PUBLIC TRAVEL. (The Law relating to Bicyclists, Horsemen and Pedestrians.) Compiled and annotated by Arthur S. Willson, B.A., Toronto, Ont., 7th September, 1897.
9445. PHOTOGRAPH OF THE STEAMSHIP "ISLANDER" LEAVING VANCOUVER, BRITISH COLUMBIA, FOR SKAGWAY BAY. Thomas McNabb Jones, Vancouver, B.C., 7th September, 1897.
9446. PHOTOGRAPH R. M. STEAMSHIP "EMPRESS OF INDIA." Edwards Brothers, Vancouver, B.C., 7th September, 1897.
9447. PHOTOGRAPH 537 STOPE IN CLIFF MINE, ROSSLAND, BRITISH COLUMBIA. (Flashlight.) Edwards Brothers, Vancouver, B.C., 7th September, 1897.
9448. PHOTOGRAPH 538 STOPE IN CLIFF MINE, ROSSLAND, BRITISH COLUMBIA. (Flashlight.) Edwards Brothers, Vancouver, B.C., 7th September, 1897.
9449. THE CANADIAN ANNUAL DIGEST (1896). By Charles H. Masters and Charles Morse, LL.B., Ottawa, Ont., 8th September, 1897.
9450. FREEMAN'S GRAMMATICAL EXERCISES FOR ENTRANCE AND PUBLIC SCHOOL LEAVING CLASSES. By J. A. Freeman, B.A. The Copp, Clark Co. (Ltd.), Toronto, Ont., 10th September, 1897.
9451. SA GRANDEUR MGR. PAUL BRUCHÉSI, ARCHEVÊQUE DE MONTRÉAL. (Portrait lithographié en couleurs.) Hon. G. A. Nantel, Montréal, Qué., 10 septembre 1897.
9452. SIR GEORGE ETIENNE CARTIER. (Portrait lithographié.) Hon. G. A. Nantel, Montréal, Qué., 10 septembre 1897.
9453. SIR LOUIS HIPPOLYTE LAFONTAINE. (Portrait lithographié.) Hon. G. A. Nantel, Montréal, Qué., 10 septembre 1897.
9454. HONORABLE AUGUSTE NORBERT MORIN. (Portrait lithographié.) Hon. G. A. Nantel, Montréal, Qué., 10 septembre 1897.
9455. GLENCAIRN II. (March and Two-Step.) By I. Silver. T. A. Spence, Montreal, Que., 11th September, 1897.
9456. LOVELL'S IMPROVED BILL BOOK. Robert James Lovell, Toronto, Ont., 11th September, 1897.
9457. SIR WILFRID'S PROGRESS THROUGH ENGLAND AND FRANCE IN THE JUBILEE YEAR. By A.M.R. Gordon. Illustrated by J. C. Innes. A. M. R. Gordon, Montreal, Que., 13th September, 1897.
9458. MEDICAL AND SURGICAL GYNÆCOLOGY. By R.W. Garrett, M.A., M.D., Kingston, Ont., 13th September, 1897.

9459. INTRODUCTION À L'ARITHMÉTIQUE ET AU CALCUL MENTAL: Par C. S. V. (Livre du Maître.) A. Archambault, C. S. V., 8<sup>e</sup> qualité des Clercs Paroissiaux ou Catéchistes de Saint-Viateur. Outremont, Qué., 13 septembre 1897.
9460. GOOD OLD UNCLE JOSH. HIS GREAT GENEROSITY TOWARDS HIS NEWLY-MARRIED NIECE. (Newspaper advertising story.) W. S. Guthrie, Windsor, Ont., 13th September, 1897.
9461. THE DELINEATOR. (A Journal of Fashion, Culture and Fine Arts), October, 1897. The Butterick Publishing Co. (Ltd.), New York, N.Y., U.S.A., 13th September, 1897.
9462. THE GLASS OF FASHION UP TO DATE. (October, 1897.) The Butterick Publishing Co. (Ltd.), New York, N.Y., U.S.A., 13th September, 1897.
9463. BERMUDA'S CORAL STRAND. Words and Music by C. G. Hill. A. & S. Nordheimer, Toronto, Ont., 14th September, 1897.
9464. GRAND-LIVRE POUR FROMAGERIES ET BEURRERIES. Joseph de Labroquerie Taché, St. Hyacinthe, Qué., 14 septembre, 1897.
9465. THE CANADIAN MAGAZINE. (September, 1897.) The Ontario Publishing Co. (Ltd.), Toronto, Ont., 15th September, 1897.
9466. LOVELL'S COLLECTORS' BOOK. Robert James Lovell, Toronto, Ont., 15th September, 1897.
9467. CATALOGUE OF HYDRANTS, VALVES, PIPES, ETC. St. Lawrence Foundry Co. of Toronto (Limited), Toronto, Ont., 15th September, 1897.
9468. THE ADVANCE GUARD MARCH. (For the Pianoforte.) By Paul Krugger. Willimott H. Billing, Toronto, Ont., 15th September, 1897.
9469. FAIR TORONTO. Words and Music by Johanna Cooke Norris, Toronto, Ont., 16th September, 1897.
9470. OLIVE WALTZES. By W. H. Hodgins. Amey & Hodgins, Toronto, Ont., 17th September, 1897.
9471. THE METRIC DESK RULE. William S. Johnstone, Montreal, Que., 17th September, 1897.
9472. RUSH TO THE KLONDYKE. (Song.) Words and Music by W. T. Diefenbaker. Willimott H. Billing, Toronto, Ont., 18th September, 1897.
9473. INTEREST TABLES. (Showing simple interest on one dollar at 3 $\frac{1}{2}$ , 4, 5, 6, 7 and 8 per cent, for any number of days in the year, and compound interest and amount of one dollar at 3, 4, 5 and 6 per cent for any number of years from one to sixty.) With Appendix. By C. E. Lund, Sackville, New Brunswick, 18th September, 1897.
9474. PHYSIOLOGY AND HYGIENE NOTES. By G. E. Henderson and Chas. G. Fraser, Toronto, Ont., 20th September, 1897.
9475. ARITHMETIC EXERCISES FOR SECOND BOOK CLASSES. By G. E. Henderson and E. W. Bruce, B.A., Toronto, Ont., 20th September, 1897.
9476. ARITHMETIC EXERCISES FOR THIRD BOOK CLASSES. By G. E. Henderson and E. W. Bruce, B.A., Toronto, Ont., 20th September, 1897.
9477. L'ANCIEN BARREAU AU CANADA. Publié dans "La Revue Légale," Montréal. J. E. Roy, Lévis, Qué., 20 septembre 1897.
9478. ALICE ET BERTHA. (Fantaisie Brillante.) Par Dame Camille Marengo, Montréal, Qué., 20 septembre 1897.
9479. MANUEL ABRÉGÉ DU SYSTÈME MÉTRIQUE. Par J. L. Vincent, Longueuil, Qué., 21 septembre 1897.
9480. CAHIER DE COMMERCE. (Conforme à la Méthode de Commerce.) Par F. T. D. M. S. (Cours Élémentaire.) J. E. Mercier, Lévis, Qué., 22 septembre 1897.
9481. BICYCLE CLUB PARADE SONG. Words and Music by W. G. Workman, Ottawa, Ont., 23rd September, 1897.
9482. SOLDIERS OF FORTUNE. By Richard Harding Davis. Charles Scribner's Sons, New York, N.Y., U.S.A., 23rd September, 1897.
9483. DOROTHY. (Two-Step.) By Adelaide Johnson. The Anglo-Canadian Music Publishers' Association (Ltd.), London, England, 24th September, 1897.
9484. BIRD'S-EYE VIEW OF THE MCGILL UNIVERSITY, 1897, MONTREAL, CANADA, WITH KEY THERÉTO. Eugene Haberer, Montreal, Que., 24th September, 1897.

- 
9485. IMPROVED DIRECTORY PRINTED INDEX FOR COPYING LETTER BOOKS. Hart & Riddell, Toronto, Ont., 25th September, 1897.
9486. THE HOUSEKEEPER'S DAILY EXPENSE BOOK. Claud Hobday, Montreal, Que., 25th September, 1897.
9487. A HOT TIME IN THE OLD TOWN. Words by Joe Hayden. Music by Theo. A. Metz. Whaley, Royce & Co., Toronto, Ont., 28th September, 1897.
9488. THE LIFE AGENTS MANUAL. R. W. Smith, Montreal, Que., 29th September, 1897.