

Technical and Bibliographic Notes / Notes techniques et bibliographiques

The Institute has attempted to obtain the best original copy available for scanning. Features of this copy which may be bibliographically unique, which may alter any of the images in the reproduction, or which may significantly change the usual method of scanning are checked below.

L'Institut a numérisé le meilleur exemplaire qu'il lui a été possible de se procurer. Les détails de cet exemplaire qui sont peut-être uniques du point de vue bibliographique, qui peuvent modifier une image reproduite, ou qui peuvent exiger une modification dans la méthode normale de numérisation sont indiqués ci-dessous.

- | | | | |
|-------------------------------------|---|-------------------------------------|---|
| <input type="checkbox"/> | Coloured covers /
Couverture de couleur | <input type="checkbox"/> | Coloured pages / Pages de couleur |
| <input type="checkbox"/> | Covers damaged /
Couverture endommagée | <input type="checkbox"/> | Pages damaged / Pages endommagées |
| <input type="checkbox"/> | Covers restored and/or laminated /
Couverture restaurée et/ou pelliculée | <input type="checkbox"/> | Pages restored and/or laminated /
Pages restaurées et/ou pelliculées |
| <input type="checkbox"/> | Cover title missing /
Le titre de couverture manque | <input checked="" type="checkbox"/> | Pages discoloured, stained or foxed/
Pages décolorées, tachetées ou piquées |
| <input type="checkbox"/> | Coloured maps /
Cartes géographiques en couleur | <input type="checkbox"/> | Pages detached / Pages détachées |
| <input type="checkbox"/> | Coloured ink (i.e. other than blue or black) /
Encre de couleur (i.e. autre que bleue ou noire) | <input checked="" type="checkbox"/> | Showthrough / Transparence |
| <input type="checkbox"/> | Coloured plates and/or illustrations /
Planches et/ou illustrations en couleur | <input checked="" type="checkbox"/> | Quality of print varies /
Qualité inégale de l'impression |
| <input checked="" type="checkbox"/> | Bound with other material /
Relié avec d'autres documents | <input type="checkbox"/> | Includes supplementary materials /
Comprend du matériel supplémentaire |
| <input type="checkbox"/> | Only edition available /
Seule édition disponible | <input type="checkbox"/> | Blank leaves added during restorations may
appear within the text. Whenever possible, these
have been omitted from scanning / Il se peut que
certaines pages blanches ajoutées lors d'une
restauration apparaissent dans le texte, mais,
lorsque cela était possible, ces pages n'ont pas
été numérisées. |
| <input checked="" type="checkbox"/> | Tight binding may cause shadows or distortion
along interior margin / La reliure serrée peut
causer de l'ombre ou de la distorsion le long de la
marge intérieure. | | |
| <input checked="" type="checkbox"/> | Additional comments /
Commentaires supplémentaires: | | Continuous pagination. |

CANADIAN MAGAZINE

OF
Science and the Industrial Arts.
Patent Office Record.

Vol. 12.

DECEMBER, 1884.

No. 12.

Communications relating to the Editorial Department should be addressed to the Editor, HENRY T. BOVEY, Ontario Avenue, Montreal.

The Editor does not hold himself responsible for opinions expressed by his correspondents.

No notice will be taken of anonymous communications.

NEW BOOKS.

Traité Pratique d'Electricité Industrielle, by E. Cadiat et N. Dubost. (Paris: Baudry & Cie.)

This admirable work is designed for the use of electrical engineers and other practical men. During the past few years our knowledge of electricity and its applications has wonderfully increased, and the literature relating to it has grown in proportion. The authors of the work before us have endeavoured to condense "this literature" into a convenient and useful form, and their endeavours have been largely successful. The work is divided into six parts. The first part is devoted to a consideration of definitions, fundamental laws, and of that most important and most complex branch, electrical units and measures. The second part treats of apparatus for the production of electricity, arranged under the heads of batteries, machines, and accumulators. The theory and description of the various machines are plainly set forth and illustrated by numerical examples, which add greatly to the value of the work. In the remaining four parts, the authors deal with the questions of electric lighting, the electrical transmission of energy, electro-chemistry, and the telephones.

Electric lighting is discussed at length, the various arc and incandescent systems being carefully described. The authors here point out that in comparing gas with electric lighting, the first cost in the latter is the most important item, the cost of working being comparatively small. With gas, on the other hand, the cost of working is the main consideration.

The electrical transmission of energy is next minutely and clearly described. After a statement of general principles and preliminary experiments, the merits of the different motors are compared. Various applications are then taken up, including the Siemens' tramway, the Portrush railway, traction by accumulators, telpherage, use in the working of mines, electric boats, and in aerial navigation. This part concludes with a chapter on the distribution of electricity.

In the fifth part, the first chapter deals with electro-plating, the composition of the baths, and general principles as to the production and distribution of electricity, influence of conductors, &c., and the second chapter with electro-metallurgy.

The sixth and last part of the work is devoted to the telephone and microphone. Their theory is explained, and a description is given of the principal kinds, together with the mode of application to practical purposes, including the arrangement for a central exchange in cities.

CANADIAN PACIFIC RAILWAY.

BY VERNON SMITH, C.E.

(Continued from page 342.)

By a telegram received within the last few hours, the heavy work expected in crossing some places in the mountains which lies between the two crossings of the Columbia have been found to be not nearly so formidable as at first anticipated and a large saving both in time and money can be effected in the construction of this section. The completion of the Government section from the Pacific to Kamloops Lake enables the work upon the third and last range of mountains, the Gold Range, to be attacked from both sides and no doubt now remains that next season will see this great work completed from ocean to ocean, a great national highway across Canada; the shortest, best and most economically worked communication between the Atlantic and Pacific, the northwest passage from Europe to the Orient which has been the aspiration of so many centuries, and hitherto the grave of so many hopes.

The construction of a railway through a new, unorganized, almost unexplored, district without settlement or fixed population, especially when time is an important element in the question is an entirely different problem from constructing that same road a few years later when population has come into the country, the cultivation of the soil has commenced, roads have been constructed, and the necessaries of life have been introduced. All the requirements for the second operation are equally requisite for the original line, but very much of the difficulty of obtaining them has been removed and what is often most embarrassing and

almost impracticable for the pioneer is comparatively easy and smooth for his successor. In the instance of the Canadian Pacific Railway, and especially with Messrs. Langdon and Shepard's division of it, the case was complicated by the immense distance that intervened between the base of their operations or even the end of the track and the points where the earthwork and the bridging was being carried on, as well as by the long length of line over which these operations were being simultaneously executed. The removal of 10 million cubic yards of earth, as for instance in the Suez or Panama Canals is a heavy undertaking, but spread that same amount over 700 miles of country, and every element of cost and difficulty is wonderfully enhanced. An immense quantity of materials has in all these cases to be accumulated an army of men has to be fed and provided for, large quantities of plant and tools and appliances have to be procured, and kept in efficient repair and a vast machinery has to be maintained if the work has to be properly and systematically executed, but in this instance all this had to be done from one end of a thin line of communication and over the extended chain of its own daily increasing length. It was only by the most accurate knowledge, months in advance of every detail that was required, the most careful estimate of when and where and how each party was to be provided for and the most energetic maintenance of the long line of communication that the desired result could be hoped for. It speaks volumes for the executive ability, indomitable energy and business management of the firm that the whole was worked out with no serious hitch, that no important delays occurred and that everything progressed in the same methodical orderly manner that was observable in all their operations.

The work of grading was sub-let in small sections of a mile or more in length to almost sixty different sub-contractors according to the ability or means of each man to execute the length that he undertook, great care being exercised that these sub-contracts should be well within the limit of each man's power to complete them within the time specified and so well was this managed that only in one or two instances out of 300 separate contracts was any delay occasioned by these parties not completing their work. As soon as a gang had finished in one place they were removed forward to their next length perhaps 100 or 150 miles ahead and here again in another month or six weeks they were almost certain to be within sound of the track-laying locomotives before their work was entirely finished, nearly all the earthwork was what is usually known as side cuttings, the line being almost exclusively on an embankment the material for which is derived from two parallel ditches on either side of the line, and purposely raised at such an elevation above the prairie as to bring the rails where possible above the average level of the winter's snow. This class of work was done in three different ways; the first by digging out the ditches and casting the material taken out of the trench on the embankment. This work was generally let to three or four men by the "station" or 100 feet length, and it suited the Swedes, Norwegians and Italians who made this class of work their specialty and who often removed on an average 25 cubic yards a day for every man employed in their gangs. There is little plant or capital required for this work, and one man on the bank will level off and

dress up the labor of a score of casters employed on the ditches. The second mode, and most popular with the American workmen for removing the earth was by scraping. In this case the ditches are plowed for a length of 150 or 200 yards and the loosened material is then hauled in a rounded iron box on to the bank by a pair of horses, the scrapers removing at each haul about one-fifth of a cubic yard of material. Where the bank is alone seven or eight feet and the haul unusually long, larger scrapers or boxes are used and they are mounted upon wheels carrying as much as half a yard at each charge. This is undoubtedly the most economical way of removing earth or sand from a side ditch on to an embankment. Two horses, one man driving and one man attending to the scraper will handle easily from 60 to 100 cubic yards per day in ordinary material with the small scrapers where the haul is not long, or double this quantity with the wheel scrapers where the material is sandy, and the circumstances all favorable. There is besides, this advantage with the scrapers, that the banks became thoroughly consolidated with the constant passage of the horses and their load over them, and that when once dressed off they are less liable to subsidence and getting out of shape. The third system adopted was by grading-machines, a rather cumbersome and clumsy-looking affair and requiring from 8 to 12 horses to draw it but doing its work pretty well upon the whole and although somewhat complicated in its machinery giving less trouble than might be expected, from break-downs or the necessity of repairing the working parts. It consists of a plough mounted upon wheels and so arranged that it can be raised or lowered at pleasure by the ploughman who rides upon the framework immediately above the plough and can watch exactly the depth necessary to cut to keep it properly working. The portion cut out by the plough is turned over onto a shell table slightly inclined and from which it is pushed on to an endless band one end of which is as close to the ground as it can be arranged and the other passes over a movable pulley that can be raised or lowered and which delivers the earth at an elevation of from 4 to 8 feet above the point from which it was excavated on to the railway embankment. These machines would average from 800 to 1,000 c. y. per day but the amount of subsidence in the embankment which was generally under 10% in scraper work raised from 15 to 18% in the banks made by the graders.

Following the grading parties and just in advance of the tracklayers were two bridge gangs, working one night and the other day, and as every stick of timber had to be brought by the completed road itself, mostly from Rat Portage, 140 miles east of Winnipeg, and generally 500 or 600 miles from the place where it was required, and as it was important to reduce the freighting from the end of the track to as short a distance as possible, the bridge timber was generally brought up at night, so as to interfere as little as possible with the tracklaying. From this point it had to be hauled along the prairie eight or ten miles to the place where the bridge was to be built. Openings for water courses and the ordinary drainage of the country consisted generally of four bends of piles, four in a row, and for these structures two pile drivers were brought forward, and as soon as the piles were driven the framers were set to work cutting them off to the proper length and put-

ting on the caps and stringers. It was no uncommon thing for the framers to be up to the pile drivers as the last pile was being driven, with the bricklayers entering the bridge at one end as the last stringer was being laid at the other. The stringers were laid in pairs, 9 x 15 inches under each rail in one span, and in threes 6 x 15 under the adjoining span, resting 12 inches on the cap piece, bolted together longitudinally with splice plates 24 inches long, $2\frac{1}{2}$ x $\frac{1}{2}$ inches, and the whole drift bolted onto the cap.

The larger structures were built mostly after the rails were laid, a temporary structure having been used for the track-laying, and the permanent materials, iron and stone, being brought to the front by the railway itself. All the larger bridges are intended to be an iron superstructure, resting upon stone piers and abutments. These are not numerous on the prairie section, the most important being the one over the South Saskatchewan, at Medicine Hat, which is 1000 feet in length, 45 feet above the water, and consists of three spans of 217 feet each, two of 30 feet, and a draw 300 feet in length. The piers and abutments of this are Winnipeg limestone.

Between Calgary and the summit the Bow River is crossed eight times, requiring bridges, all of which are iron girders resting upon stone abutments, varying from 400 to 800 feet in length, and altogether on this section there are over 13,000 lineal feet of first-class bridges, or over $2\frac{1}{2}$ miles in total length.

The track-laying gang was the one that attracted the most attention, and their progress could be most directly gauged, and formed, as it were the basis upon which the daily advance of the whole work was estimated. In 1882 the average day's work varied from 2.28 miles per day, in October to 3.22 miles, in August for the seven weeks ending Sept., 47, or in 42 consecutive working days, they completed on an average 3.21 miles per day. The greatest length laid in any one day was 4.10 miles, and on three occasions the daily progress was 4 miles. The best record was a mile in 35 minutes. Remarkable as this progress was, unexampled in any previous railroad experience, it was exceeded in 1883. The greatest day's work was July 28, when 6.38 miles were laid, and the greatest month's progress, also July, when 92.35 miles of main track were laid, besides 5.11 miles of side track, or 97.46 miles altogether. In the first six working days of July, from the 2nd to the 7th inclusive, 25.86 miles of railway were completed in one week, or an average of 4.31 miles per day. Towards the last of Messrs Langdon, Shephard & Co's contract, in 48 working days the track-laying gang laid and finished 166.38 miles, or an average for the whole time of 3.46 miles per day, exclusive of the sidings which were laid about every ten miles. The track-laying gang were kept in large boarding cars, built in two stories; in the upper one the men slept, and in the lower they lived and messed. Each car afforded sleeping accommodation to 80 men. These cars, with the necessary cooks, inspectors and workshop cars, formed a permanent train and were always left at the front. The rails, $57\frac{1}{2}$ lbs. to the yard and 30 feet long, were about half from the Prussian works of Krupp, and the remainder English. They are of the ordinary flat foot pattern, and were mostly brought up from Montreal by rail, *via* St. Paul and Winnipeg, a railway journey averaging 1500 miles.

After being landed in this country, they were taken up, according to convenience, and stacked ready for use at construction depots, which were placed about 100 miles apart, and where all the material for the track was sent as near to the work as possible. From these construction depots trains were sent to the nearest siding to the front, taking an accurately adjusted supply of rails, ties, and other requirements for one mile of track. These trains consisted of 20 flat cars; the ties, or sleepers, of which there were 2,640 to a mile, were loaded 300 to a car; the rails were loaded 30 pairs to a car, besides 5 boxes of spikes, weighing 1 cwt. each, 60 pairs of fish-plates and one box of bolts.

By this arrangement there were no surplus materials left scattering along the line, no redundancy of supplies in one place and no scarcity in another. The working construction trains brought up these materials from the nearest siding to the end of the track. The ties were here loaded into carts and carted along the side of the line to where they were worked, distributed, spaced and lined for a considerable distance ahead of the track-layers. The rails were unloaded on each side of the track in equal quantities. The engine then went back, and a trolley drawn by horses was run up, on which 15 pairs of rails were loaded with the necessary fish-plates, bolts and spikes. When the trolley reached the last rail laid, a pair of rails were taken off, laid in place, gauged, and the trolley run forward. A gang followed, linking on the fish-plates, then three gangs of spikers, the first gang spiking the ends and the centre, and the others following till the whole was spiked. When the last rail was laid a second trolley was brought up, and the first thrown off the rails to let it pass, then replaced and sent back for another load. On the 7th July, when the six miles were laid, there were 24 men to handle the iron—that is, 12 unloading it from the cars and 12 to load the trollers. It took the same number to lay it down in the track. The total number of rails laid that day was 2,120, or 604 tons; 5 men on each side of the front car handed down 1,060 rails, whilst the two distributors of angle plates and bolts handled 2,120 rails, 4,240 plates and 8,480 bolts.

These were followed by 15 bolters, who put in on an average 565 bolts each; then 32 spikers, with a nipper to each pair, drove 63,000 spikes, which were distributed by 4 peddlers. The lead and gauge spikers each drove 2,120 spikes, which, averaging 4 blows to a spike, would require 600 blows an hour for 14 hours. There were 16,000 ties or sleepers unloaded from the trains and re-loaded into waggons by 32 men, and 33 teams hauled them forward onto the track, averaging 17 loads, of 30 sleepers to each team. On the track 8 men unloaded and distributed them and 4 others spaced them, 20 others spaced and distanced the joint ties, and 20 others arranged and adjusted displaced ties immediately in front of the leading spikers. Four iron car boys and six horses hauled the iron to the front.

When the great distance over which all this material was brought is taken into account, with the immense daily demand, continued without intermission week after week, it will appear to have been no small feat to have kept all this moving to the front so regularly and with such punctuality that during the two seasons the longest delay for material that ever occurred was not over three hours' duration. At points about 130 miles

THE "CASTALIA" HOSPITAL SHIP.

MR. ADAM MILLER, ENGINEER.

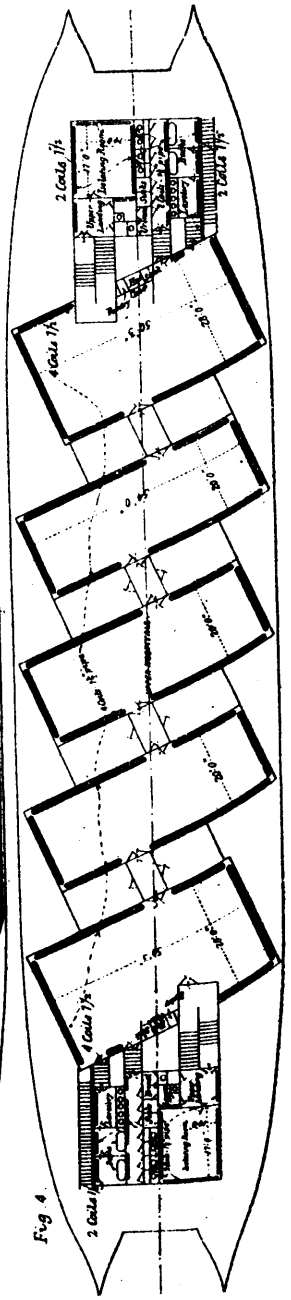
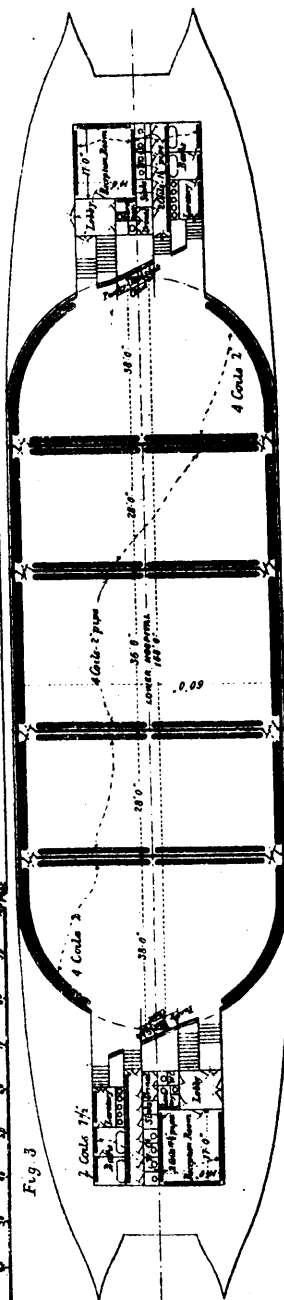
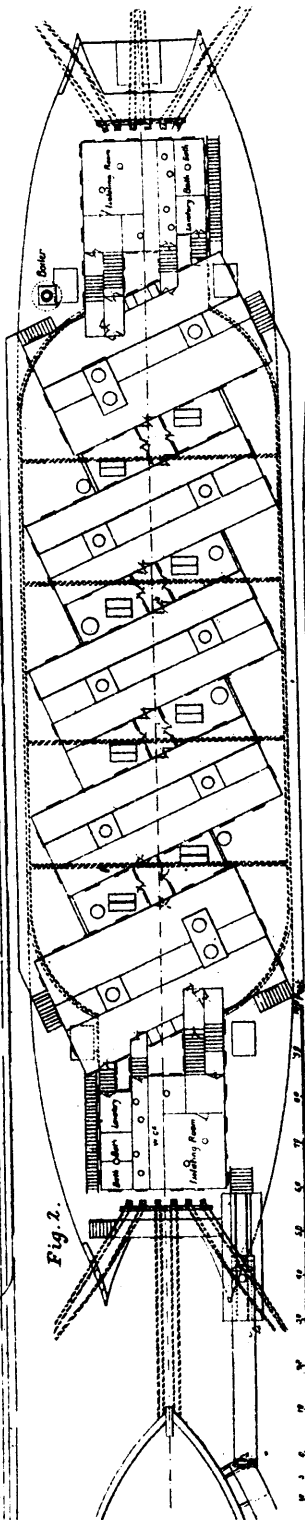
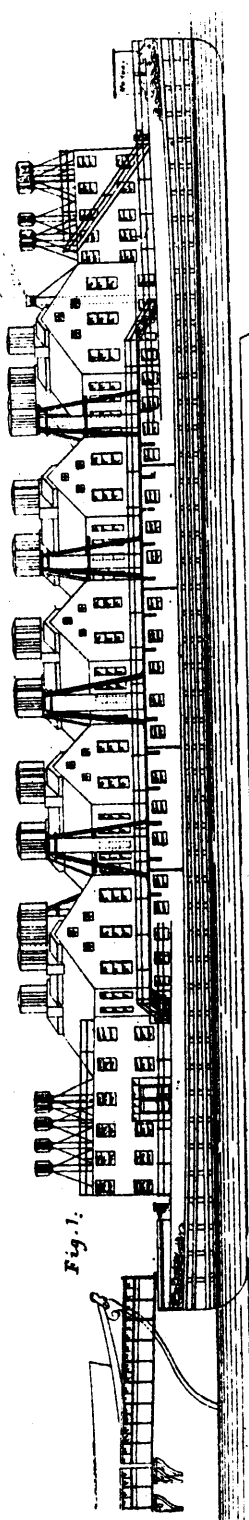

apart, divisional depots were organized, with engine sheds, coal yards and shunting grounds, and at every alternate division repairing shops for the engines and cars were fitted up with the best machinery. The telegraph line was built simultaneously with the track-laying, and every night the wires were connected with a temporary office at the end of the track, and placed in communication with Winnipeg, about 150 men being employed on this service.

After the tracklayers came the surfacing gang. After the rails were laid these men immediately lifted the track, lined the rails and packed the sleepers with the material of the embankments. The beams outside the ends of the ties were then taken off, and the material was thrown in between the rails to a height of two inches above the ties, forming a regular convex surface, which soon hardens with the sun and sheds the water perfectly. By this means the necessity for ballasting is not pressing, and none was put in in 1882 or within 12 months after the rails were laid, and the surface of the sub-grade is in a better condition for the ballast than without this preparation. 150 men were employed on this surfacing, and their advance gang was kept close to the track-layers, so that immediately after the rails were laid the trains could run 25 or 30 miles an hour without any damage to the rails; the line had a good surface, and the absence of ballast was no detriment.

In addressing a British Association, it may not be amiss to call attention for a moment to the relative merits of the Canadian Pacific over other trans-continental railways in its commercial and political aspects. Our line is, from ocean to ocean, in round numbers, 400 miles less than the rival route from San Francisco to New York. In alignment, curvature, and every other engineering question, it is a superior line, and can be proved more economical per mile. It has nothing like the amount of capital involved, and both mechanically and financially it has advantages that are not discounted or offset by any inferiority in any respect to its Southern rival. It passes over a summit 3,000 feet lower, and has not to contend with any serious climatic difficulties, such as experience shows are a heavy drawback on the Central Pacific. Montreal is nearer to England than New York in summer by 200 miles, and the Canadian Pacific terminus is 400 miles nearer than San Francisco to any of the important Asiatic ports. There is a saving of 1000 miles from Japan or China to Europe by the Canadian route, and nothing to offset this disadvantage of the American system. There is no mysterious difficulty in explaining this. The one line follows pretty nearly the line of the 41° parallel of latitude, the other averages about 50°, the length of a degree, is about 8 miles shorter on the Canadian line (so that the further the journey is continued, the greater absolute saving in distance will be shown). But Montreal is closed by the ice in winter, and Canadian traffic must seek a more eastern port and betake itself to one of the Nova Scotian harbors, which, like New York, are open throughout the year. From Louisburg, our most eastern harbour, to the Pacific, will be about 3,600 miles, or 300 miles longer than from New York to the Pacific. Louisburg is 750 nautical miles nearer to England than New York, and, taking 15 knots per hour as the fastest winter speed that we may look for on the Atlantic, and 30 miles per

hour for railways, there is a saving of 40 hours, either winter or summer, between England and the Pacific by our Canadian route. The saving on the Pacific is quite as much. The great Japan current sweeping to the north is deflected by the shape of the coast of the north Pacific, and a vessel from China and Japan to take advantage of this would follow very nearly the same track, whether she were bound to British Columbia or San Francisco, 700 miles to the south.

Allowing that there is not the same advantage going in the other direction, there is still over 400 miles, and the total saving in time at the speed estimated would make about 72 hours, or three full days, as the same time by the Canadian Pacific. As if to mark this as the future route of commerce, nature has placed at either end of this route, in Nova Scotia and Vancouver Island, such immense stores of coal, that whatever may be the anxiety in England on the subject of their mineral deposit of fuel, there need be no apprehension on that head at either end of the Canadian Pacific. The only coal deposits on salt water that are comparable in price and quality to these Canadian deposits, are the Australian coal fields of Sydney, and it is somewhat remarkable, that, in circum-navigating the globe after passing these last, no other available coal seams would be encountered until England would be again reached. As long as cheap coal is the basis of economical navigation, the line that passes these coal fields would seem to be the one that possesses the greatest advantages between England and the East. If coal is the oxygen of commercial activity, that, in its turn, is the spring of individual and collective wealth, of political importance, of natural prosperity. It is in the hope and under the belief that this Pacific Railway is destined to be one of the principal factors in the future progress and development of this country that it has enlisted the sympathy of the great majority of the Canadian people, and it is the pledge given by its rapid progress and energetic management that has lifted it out of the position of a local or sectional enterprise and made it of Dominion and national importance. As England is mistress of the seas, and as this is the most complete and convenient inter-oceanic link between the Atlantic and Pacific, Canada trusts to see her great railway the main highway between Great Britain and all her Asiatic and Australian dependencies.

LUMINOUS PAINT.—Luminous paint continues to make slow but steady progress in its application to innumerable useful purposes. Among its most recent applications may be mentioned tapes for field use at night by the Royal Engineers department. Starting from a given point towards the front the men leave a trail of luminous tape on their track, and on reaching a given point they mark the contour of the earthworks to be executed by the same means, paying out the tape as they return towards the camp. The working party then follow the outward trail, execute the work, and return to camp without the having discovered a single ray of light to the enemy. The German War Office authorities have experimented with the paint for purposes of night attack, and Lieutenant Deppe, of the Belgian School of Gunnery, is investigating its merits in the same direction. Our own Government are also using painted framed glasses, or Alladin's lamps, as they are called, for internal boiler inspections. General Lord Wolseley also took with him a luminous compass for the Nile expedition. It has also been applied in some large establishments to the fire buckets, which are thus easily found in the dark. The latest application of luminous paint is that of a South-Eastern Railway third-class carriage, the interior of which has been lined with the paint on the back of glass.

THE HOSPITAL SHIP "CASTALIA."

The twin-ship *Castalia* was bought some little time ago by the managers of the Metropolitan Asylum Board, to convert into an hospital for small-pox patients. The managers had the matter before them of making floating hospitals on pontoons, and this vessel the *Castalia*, suited their views very well; they entrusted the conversion of the vessel into an hospital to Mr. Adam Miller, of Riches court, Lime street, London.

It was decided to make five large wards of the old cabin arrangement, and to build other five wards on the top, and place them in echelon (Figs. 1 and 2, page 356), so as to have them at angles with the centre line of the ship; giving more air, better light, and also reducing the number of patients in each ward; in fact these upper wards are each a cottage hospital of itself. The dimensions of the wards vary a little, but the height is 23 ft., that is to say, the walls are 13 ft. and the roof 9 feet. The windows are made similar to those in the hospitals on land, and are 7 feet by 3 feet.

The inlet of air is by slides worked by a screw, so that the quantity of air admitted may be graduated to the amount required. The air is drawn out by Boyle's extracting ventilators; each ward has two of these large ventilators, and, in the event of calm, close, sultry weather, there is fitted to each ventilator an air blast, sent up from a large Farmer blower of Schiele's make, fitted in the engine-room below. This blast of air is sent up the pipes of the ventilators and causes an upward current of air to take place in these pipes. In this way the wards are kept cool and the air changed so many times an hour in each ward.

Each of the isolating rooms, bath rooms and lavatories, is fitted with Boyle's ventilators and air inlets similar to the wards. The hospital throughout is heated by steam coils, fitted by Messrs. Ridsdale & Co., Minorities, London, each coil having a separate inlet and outlet into silent blow-off pipes. The temperature in any compartment may be raised or lowered as required, or as the doctor decides.

The upper hospitals with the isolating wards (Figs. 1 and 2) contain a large cubical space. There are attached to these upper wards, at each end of the vessel, outhouses for the use of patients; these contain four bath-rooms, ten wash basins, eight water-closets, four latrines or sinks, and two urinals. One hot closet or hot carving table (Fig. 4) is fitted up and heated by steam, in each of the end upper wards; this is to keep the food warm for the patients. A scullery is also fitted up in each of the end wards for washing up dishes after meals.

The upper hospital wards are built with coamings of plate iron 15 in. by 4 in., rivetted to an iron deck, which covers the lower hospital (Fig. 7, page 357). Frames of angle iron are rivetted at regular intervals to this coaming, they stand up 13 ft.; the roof principals spring from this height, and they are also made of angle iron. The sides, ends, and roofs are planked with yellow deal horizontally. The sides and ends have also a cross lining on the outside of American yellow pine, making the thickness 2½ in. The roofs are covered all with 6 lb. lead, instead of coass-lined with yellow pine.

The lower wards of the hospital ship are five in number (Fig. 3, page 356), and are arranged to make use of the iron bulkheads that are fixed across the two vessels, binding the hulls together. These divided the *Castalia* into first and second saloons, &c., for passengers. The sides and ends of the lower wards are made of iron plate; the upper deck which forms the roof is plated all over with iron plating and covered with 2½ in. pine deck planks, caulked water tight. The lower wards are thus really cased with iron. They are similarly supplied with lavatories, hot closets, and sculleries, as the upper wards; two skylights are provided in each ward to assist in giving light from above. The windows are all made as large as possible, they are 3 ft. 6 in. by 1 ft. 6 in., divided into three sashes, similar to the upper windows.

The means of ventilation are, of course, much greater in the lower wards than the upper ones; the lower wards being much larger and not so high in the roof, the height from deck to deck being 8 ft.

At both ends of the lower and upper wards large isolating wards are fitted up. These rooms are provided for the purpose of isolating patients who may have been sent under the mistake that they are suffering from small-pox, and who prove, when examined at the ship by the medical staff, to be affected with measles, fever, &c. Every care is taken that the patients with other diseases than small-pox shall not come into contact with any small-pox patients.

The patients are brought to the hospital ship by the ambulance steamers (Figs. 8, 9, and 10) and are taken first into the reception room and there examined, and are then allotted to the wards by the resident doctor. The separation of the sexes is rigidly enforced. The *Atlas* is now kept as a female hospital and the *Castalia* has been made a male hospital. The whole of the *Castalia* has been painted with Griffith's white paint and the Sanitary Company's enamel paint; every precaution has been taken, by painting, to prevent the germs of this disease from getting into the woodwork. Mr. Wythe, of Dalston, executed the paintwork. Messrs. R. & H. Green were the contractors to convert the *Castalia* into a hospital ship. Messrs. Jas. Patterson and Co., of Ratcliff Engine Works, Stepney, supplied and fitted up all the machinery and pipes for the air blast and the pumps for throwing water, for the water closets, washing decks, fire hose, &c. The engines are of the compound type, with cylinders 10 in. and 20 in. respectively, with a stroke of 2 ft. They are constructed to drive the Schiele's fan, and also a dynamo machine for the electric lighting if required.

Very great attention and care was given to the ventilation of the hospitals. Professors F. De Chaumont, Dr. Bridges, Surgeon-General Bostock, and Mr. Barrington Kenneth discussed the matter fully and arranged that Boyle's air-pump ventilators should be adopted. They also fixed the dimensions of these ventilators for the several wards according to the space to be relieved. The ventilators were tested one day during a smart breeze, and the speed, registered according to three anemometers placed in the ventilators, was at the rate of 500 ft. per minute, giving 50 per cent. of the speed of the wind blowing outside, so that the atmosphere in the hospitals may be changed many times in an hour. Dr. Birdwood has since found that he can raise or lower the temperature in a few minutes, and he has caused the wards (when empty) to be filled with smoke by burning greasy waste, brown paper, cayenne pepper, &c. The fan blowers were put on, and in from three to four minutes all the smoke was cleared off.

The ventilators were made each with heads 6 ft. in diameter, and were fitted with pipes varying from 3 ft. 9 in. to 2 ft. 6 in. in diameter. The lower wards have two ventilators 3 ft. 9 in. and eight of 3 ft. 3 in. The upper wards have four ventilators of 3 ft. and six of 2 ft. 6 in. The lavatories and isolating-rooms have sixteen ventilators of 16 in. diameter. The cubical contents of the lower hospital are 73,465 ft.; the superficial area, 9308 ft.; the window opening, 984,44 sq. ft. The cubical contents of the upper hospital are 84,607 ft.; the superficial square area, 6054 ft.; the window opening, 1792.52 sq. ft.

To provide for the satisfactory embarkation of passengers piers are provided at various points by which they can be transferred from the ambulance to the steamer free from contact with the public. The first of these is the Longreach pier, which is erected close to the hospital ships lying off Purfleet at Longreach. The patients embark and disembark to and from the ambulance steamers, and to the hospital ships, as may be arranged. The pier also accommodates the laundry staff in going and returning from their work from the staff ship *Endymion*. It is 193 ft. in length over all; the moving portion is 125 ft. long, the fixed part is 68 ft. in length. The pier is lined throughout with yellow pine, and roofed over with glass, so as to keep the patients and others from getting wet. The moving portion of the pier rests at one end on a pontoon, which rises and falls with the tide; the other end is fixed to a stack of piles by a joint bolted to each of the girders, and also securely bolted on the piles. The fixed portion of the pier is also bolted to the same joint, thus making the connection of the moving and fixed parts. The pier is made so that ambulance may be taken down or up, with or without the horses. A porch has been built upon the pontoon; it is fitted with a waiting-room, stove, water-closet, urinal, &c.

A similar porch with conveniences is erected at the land end of the pier. The ambulance drive into this porch to take in or discharge patients under cover. The Rotherhithe Pier at Acorn Wharf is of similar design and accommodation, but is not roofed in. The length of Acorn Pier is two fixed spans each of 84 ft. and one moving span of 125 ft., in all 293 feet. The contractor for both piers is Mr. S. Chafen, Albion street, Rotherhithe. The pier at Acorn Wharf is for the accommodation of patients lying in the south-eastern districts.

There is a pier building for Blackwall at Brown's wharf for the accommodation of patients living at the east end of London. This pier will only consist of a moving part of 125 ft. in length, resting on a pontoon similar to the other in accommo-

SILVER ORE AMALGAMATION.

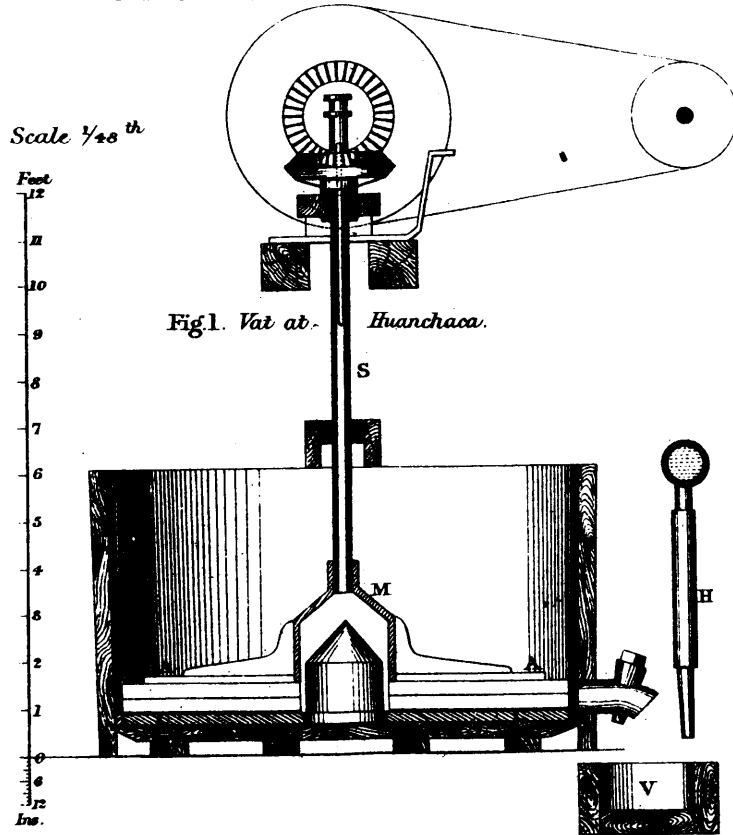
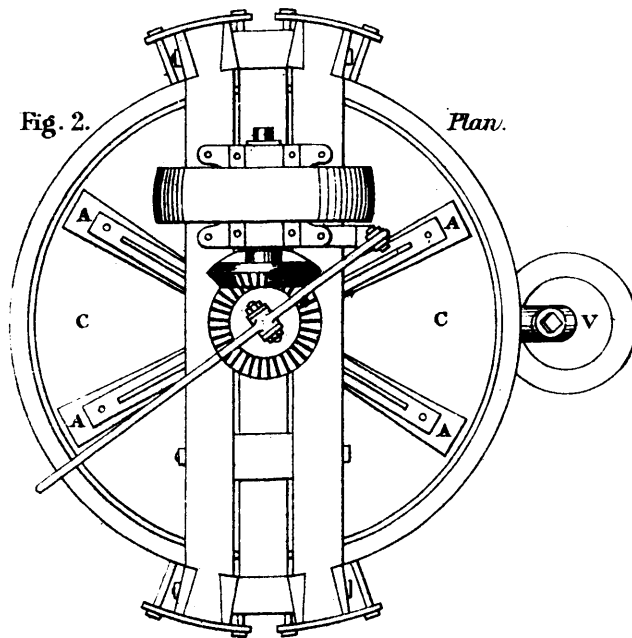

Fig. 2. Plan.



SILVER ORE AMALGAMATION.

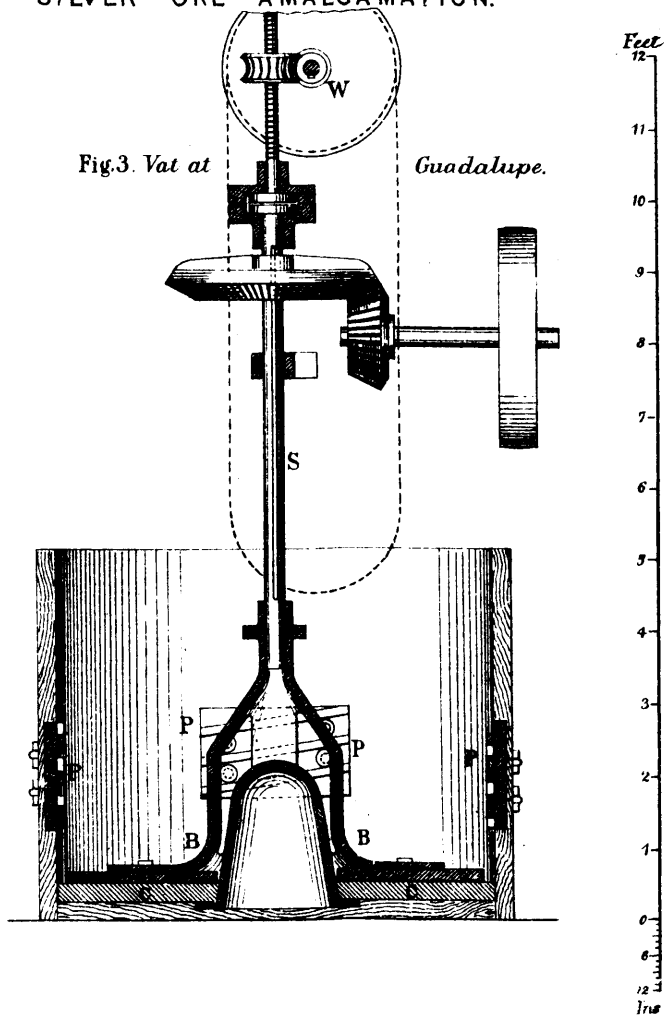
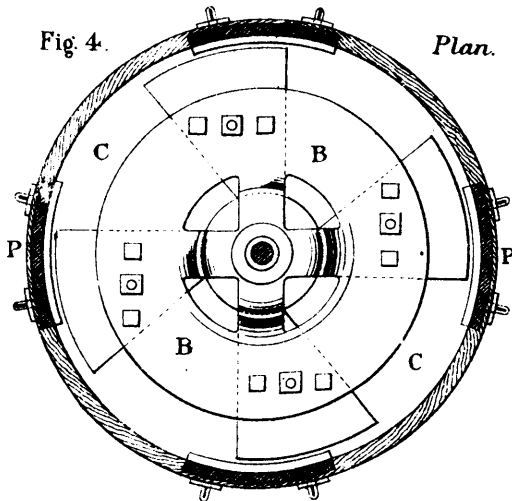

Fig. 4.

Plan.



dations, &c. The wharf at which this pier is to be attached will be roofed in so that all the ambulance may be accommodated on the wharf, and shut in from the street, and that the public may be kept clear.

The fourth pier is to be erected close to Wandsworth bridge; it is to be for the accommodation of patients in that district. This pier will be similar to Blackwall Pier. These piers have been designed by Mr. Adam Miller, and are being erected under his superintendence. The *Endymion* and the *Castalia* are connected by a covered gallery (Figs. 6 and 7), which will allow a certain relative motion of the two vessels.

There are, in connection with the *Castalia*, three steamers for the ambulance service, viz., Red Cross, Albert Victor, and Maltese Cross. The illustrations, Figs. 8, 9, and 10, page 357, represent the latest, the Maltese Cross, built by Messrs. Edwards and Symes, Cubitt Town, E. This steamer is designed with two hospitals, viz., one aft and one forward, and is made to carry twice as many patients as the first steamer, Red Cross, constructed by the same builders. The dimensions of this steamer are as follows: Length, 132 ft.; breadth, 16 ft. 6 in.; depth, 7 ft. 6 in. The engines are of the oscillating type, with cylinders of 23 in. diameter, with 30 in. stroke, steam pressure of 40 lb.

The hospital arrangements for the patients in the matter of beds and conveniences, ventilation, &c., have been carried out to the instructions of Surgeon-General Bostock, who has taken a great interest in all the ambulance arrangements. The accommodation for the crew is put forward. The captain and medical officer are placed on deck abaft the boiler casing. The nurses have a berth in each hospital; a store-room is made under deck, right aft the transom for medical comfort. Filtered water cisterns are placed on deck at each entrance to the hospitals; a galley, with a cooking range, is fitted at one of the wings of the paddle-boxes, so that in the event of the ambulance steamer being delayed by fog in the river the patients would have the same comfort as in the hospital proper.

The ambulance steamers have also been designed by Mr. Adam Miller, and the Albert Victor has also been converted by him into an ambulance steamer.

The ratepayers, or the outside world, have not any idea of the great amount of attention and labour given to the asylums of London by the chairman, Mr. Galsworths, and the managers of the Metropolitan Asylums Board. During an epidemic many of the managers simply work night and day. The chairman, Sir Edmund Hay Currie, of the General Purposes Committee, and the members of that Committee, may be seen at work often at midnight, on Sundays, as well as other days, getting patients sent on to the hospital ships.—*Engineering.*

THE COST OF MAKING STEEL RAILS.

The actual cost of producing a ton of steel rails in Pittsburgh is placed by a local paper at \$26.83, shown by the following itemized statement:

COST OF PIG METAL.	
11-10 tons of coke, at \$2	\$ 2 20
Limestone	50
Ore, scale, etc.	10 00
Labor, including repairs	1 75
General expenses	38
Interest	35
Cost of a ton of metal	\$15 18
COST OF INGOTS.	
11-5 tons of metal direct, at \$15.18	\$18 12
Refractories	20
Lubricants	2
Repairs	24
General repairs	17
Labor	1 13
General expenses	9
Spiegel	2 31
Interest	10
Cost of a tons of ingots	\$23 48
COST OF RAILS.	
1.05 tons direct with initial heat, at \$22.48 per ton	\$23 62
Labor and office expenses	1 90
Repairs entire	49
Steam (natural gas)	10
General expenses	35
Interest	22
Tools, files, etc.	15
Cost of a gross ton of steel rails	\$26 83

The paper also states that the cost of making a ton of steel rails in England at present is \$20.17.

AN ELECTRO-DYNAMOMETER WITH EXTREMELY LIGHT SUSPENDED COIL.—(Nature.)

In my former communications to *Nature* it has, I believe, appeared (1) that the induction currents used by Du Bois Reymond, Duchéne, and other observers for physiological and therapeutical purposes were only arbitrarily and very insufficiently measured; (2) that the simplest and most practical instrument for their measurement is a delicate electro-dynamometer; (3) that in consequence of their extreme smallness, every available method must be employed to reduce the sluggishness of such an instrument without impairing its accuracy; (4) that an instrument of this character, shown by me before the Physical Society at Oxford in June, 1882, had answered very well, indeed better than a more expensive apparatus designed by Prof. Kohlrausch for larger currents.

It was, however, objected that there is an insurmountable difficulty in keeping a good contact between the aluminium and silver-gilt wires used in it for suspended coil and suspending wire respectively.

At the British Association meeting in Montreal I was able to show an improved form of the contrivance, in which this difficulty was surmounted; and, in addition, a method of damping the oscillations, which, while improving the insulation, enabled the weight of the suspended coil, on which the force of the torsion couple depends, to be varied between limits practically infinite.

The contact difficulty is met by taking a small plate of ebonite 3 mm. by 5 mm. in size, and tapping into it two small gold screws, long enough to project through, and carry two little nuts on the opposite sides. To the two screw heads the ends of the aluminium coil, bent into rings and filed flat, are firmly screwed; under the two nuts are twisted the ends of the gilt-silver suspension wires; the nuts are then similarly screwed home. Ebonite is elastic enough to render the junction air and fluid-proof.

The second requirement was attained by coiling the aluminium wire in a thin tube of cork, and immersing it in a vessel filled with petroleum oil. Aluminium is about two and a half times heavier than water, nearly three times the specific gravity of this oil; whereas cork floats on it. Consequently, by properly proportioning the amount of cork relatively to the wire coiled on it, any desired specific gravity from absolute flotation to that of aluminium itself can be obtained. It is even practicable to load the coil, like a Sykes's hydrometer, by dropping glass beads on a vertical aluminium wire in the axis of rotation. Here they have scarcely any influence on the swing of the coil. The damping effect of the oil, which is contained in a small globular receptacle, like a fish-bowl, between the fixed coils, is very complete and satisfactory. I had the pleasure of presenting the first rough instrument thus made to Prof. Johnson for the physical laboratory of McGill College.

W. H. STONE.

INCANDESCENCE ELECTRIC LAMPS.

Recent improvements in the manufacture of incandescence lamps have very much reduced the consumption of electrical energy, which was, say two years since, necessary for the production of a given candle power.

For a lamp giving an illuminating power equal to 20 standard candles, it is claimed that for this type of lamp, which appears to be the one most generally employed, only 2 1/2 watts per candle power are required.

It need not be said how important this is in the more economical production of the electric light, but it might be asked whether the carbon filaments of such lamps are as long lived as those older loops which demanded a greater expenditure of electrical energy to obtain a given result.

It has recently been brought to our notice that in several installations in which a well-known incandescence lamp has been used, the number of filaments which have given way after a few weeks use is quite appalling, although the lamps were worked at an electromotive force some 5 or 6 per cent. lower than they were intended for.

The question, then, is whether the economy in the current strength is not more than counterbalanced by the increased expenditure for new lamps.

It is a very noticeable fact that in the Edison system the lamps appear to be in much the same condition, as regards consumption of electrical energy, as they were several years

ago, and for a light of 16 candles more current is required than is used in some other lamps for the production of 20 candle power. On the other hand, it is very evident that the comparatively low state of incandescence of the Edison filaments is conducive to long life. Which system then is the more economical in the long run, that in which the electrical energy is reduced to $2\frac{1}{2}$ watts per candle power with a probable duration of 400 to 500 hours, or even less, as the life of the lamp, or that demanding $3\frac{1}{2}$ to 4 watts per candle power with a certainty of the lamp lasting over 1,000 hours?

The cost of incandescence lamps is not so small as to be overlooked as an item in the working expenses of an electric lighting installation; indeed, at the present prices any excessive number of failures forms a most serious consideration.

This matter has been brought forward with a view of obtaining, if possible, some degree of information for our readers as to whether the structure of the filament has been sufficiently investigated by the manufacturers of incandescence lamps from the long life point of view.

Unless the filaments can be made to last, when taking $2\frac{1}{2}$ watts per candle power, as many hours as they did before the reduction of current strength formerly necessary to produce a certain luminosity, the value of the latest improvements must be somewhat discounted.

Some statistician with time at his command might compile a most interesting set of figures on the points enumerated above; certainly results of practical value to the consumer, at least, might be tabulated.—*Electric Review.*

DESCRIPTION OF THE FRANCKE "TINA" OR VAT PROCESS FOR THE AMALGAMATION OF SILVER ORES.*

BY MR. EDGAR P. RATHBONE, OF LONDON.

In the year 1882, while on a visit to some of the great silver mines in Bolivia, an opportunity was afforded the writer of inspecting a new and successful process for the Treatment of Silver Ores, the invention of Herr Francke, a German gentleman long resident in Bolivia, whose acquaintance the writer had also the pleasure of making. After many years of tedious working devoted to experiments bearing on the metallurgical treatment of rich but refractory silver ores, the inventor has successfully introduced the process of which it is proposed in this paper to give a description, and which has, by its satisfactory working, entirely eclipsed all other plans hitherto tried in Bolivia, Peru, and Chili. The Francke "tina" process is based on the same metallurgical principles as the system described by Alonzo Barba in 1640, and also on those introduced into the States in more recent times, under the name of the Washoe process.

It was only after a long and careful study of these two processes and by making close observations and experiments on other plans which had up to that time been tried with more or less success in Bolivia, Peru and Chili—such as the Mexican amalgamation process technically known as the "patio" process, the improved Freiberg barrel amalgamation process, as used at Copiapo, and the "Kronke" process—that Herr Francke eventually succeeded in devising his new process, and by its means treating economically the rich but refractory silver ores, such as those found at the celebrated Huanchaca and Guadalupe mines in Potosi, Bolivia. In this description of the process the writer will endeavour to enter as far as possible into details having a practical bearing on the final results; and with this view will commence with the actual separation of the ores at the mines.

Ore Dressing, etc.

This consists simply in the separation of the ore by hand at the mines; into different qualities, by women and boys with small hammers, the process being that known as "cobbing" in Cornwall. The object of this separation is twofold: firstly to separate the rich parts from the poor as they come together in the same lump of ore, otherwise rich pieces might go undetected; and secondly to reduce the whole body of ore coming from the mine to such convenient size as permits of its being fed directly into the stamps battery. The reason for this

separation not being effected by those mechanical appliances so common in most ore-dressing establishments, such as stone breakers or crushing rolls, is simply because the ores are so rich in silver, and frequently of such a brittle nature, that any undue pulverisation would certainly result in a great loss of silver, as a large amount would be carried away in the form of fine dust. So much attention is indeed required in this department that it is found requisite to institute strict superintendence in the sorting or cobbing sheds, in order to prevent as far practicable any improper diminution of the ores. According to the above method the ores coming from the mine are classified into the four following divisions:—

I. Very rich ore, averaging about 6 per cent. of silver, or containing say 2,000 ounces of silver to the ton (of 2,000 lbs).

II. Rich ore, averaging about 1 per cent. of silver, or say from 390 to 400 ounces of silver to the ton.

III. Ordinary ore, averaging about $\frac{1}{2}$ per cent. of silver, or say from 150 to 200 ounces of silver to the ton.

IV. Gangue or waste rock, thrown on the dump heaps.

The first of these qualities—the very rich ore—is so valuable as to render advantageous its direct export in the raw state to the coast for shipment to Europe. The cost of fuel in Bolivia forms so considerable a charge in smelting operations that the cost of freight to Europe on very rich silver ores works out at a relatively insignificant figure when compared with the cost of smelting operations in that country. This rich ore is consequently selected very carefully and packed up in tough raw hide bags, so as to make small compact parcels some 18 inches to 2 feet long, and 8 to 12 inches thick, each containing about 1 cwt. Two of such bags form a mule load, slung across the animal's back.

The second and third qualities of ore are taken direct to the smelting works; and where these are situated at some distance from the mines, as at Huanchaca and Guadalupe, the transport is effected by means of strong but lightly built iron carts, specially constructed to meet the heavy and tear consequent upon the rough mountain roads. These two classes of ores are either treated separately, or mixed together in such proportion as is found by experience to be most suitable for the smelting process.

On its arrival at the reduction works the ore is taken direct to the stamp mill. At the Huanchaca works there are sixty-five heads of stamps, each head weighing about 500 lbs., with five heads in each battery, and crushing about 50 cwts. per head per 24 hours. The ore is stamped dry, without water, requiring no coffers; this is a decided advantage as regards first cost, owing to the great weight of the coffers, from 2 to 3 tons—a very heavy item when the cost of transport from Europe at about £50 per ton is considered. As fast as the ore is stamped, it is shovelled out by hand, and thrown upon inclined sieves of 40 holes per lineal inch; the stuff which will not pass through the mesh is returned to the stamps.

Dry stamping may be said to be almost a necessity in dealing with these rich silver ores, as with the employment of water there is a great loss of silver, owing to the finer particles being carried away in suspension, and thus getting mixed with the slimes, from which it is exceedingly difficult to recover them, especially in those remote regions where the cost of maintaining large ore-dressing establishments is very heavy. Dry stamping however prevents many serious drawbacks, some of which could probably be eliminated if they received proper attention. For instance, the very fine dust, which rises in a dense cloud during the operation of stamping, not only settles down on all parts of the machinery, interfering with its proper working, so that some part of the battery is nearly always stopped for repairs, but is also the cause of serious inconvenience to the workmen. At the Huanchaca mines, owing to the presence of galena or sulphide of lead in the ores, this fine dust is of such an injurious character as not unfrequently to cause the death of the workmen; as a precautionary measure they are accustomed to stuff cotton wool into their nostrils. This however is only a partial preventive; and the men find the best method of overcoming the evil effect is to return to their homes at intervals or a few weeks, their places being taken by others for the same periods. In dry stamping there is also a considerable loss of silver in the fine particles of rich ore which are carried away as dust and irretrievably lost. To prevent this loss the writer proposed whilst at Huanchaca that a chamber should be constructed, into which all the fine dust might be exhausted or blown by a powerful fan or ventilator.

* A paper read before the Institution of Mechanical Engineers.—(Enc.)

SILVER ORE AMALGAMATION.
Fig. 5. *Subliming* *Furnace.*

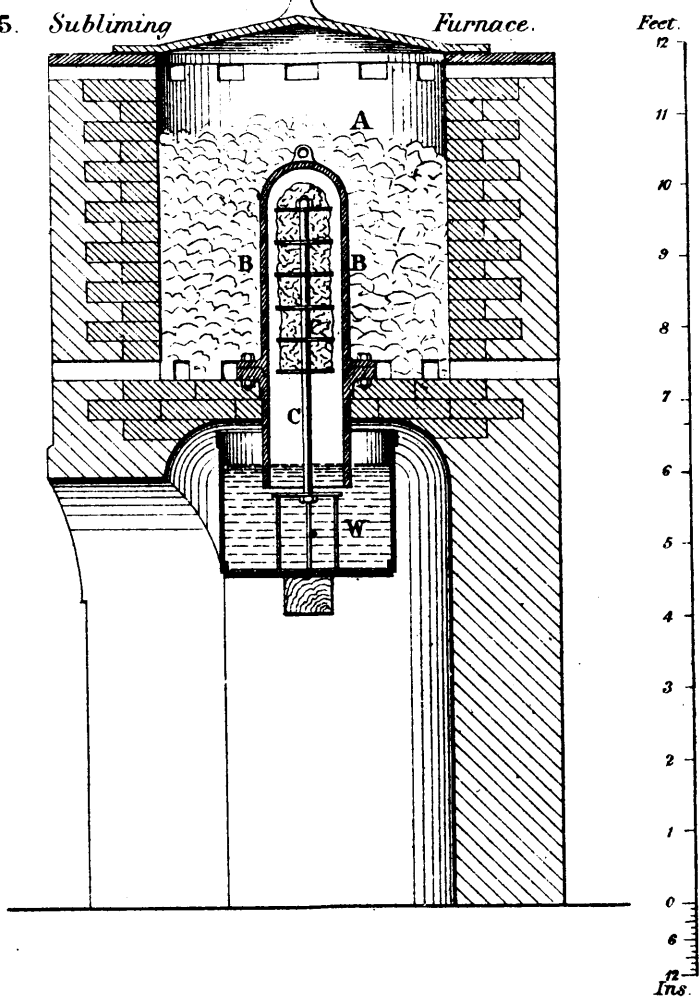
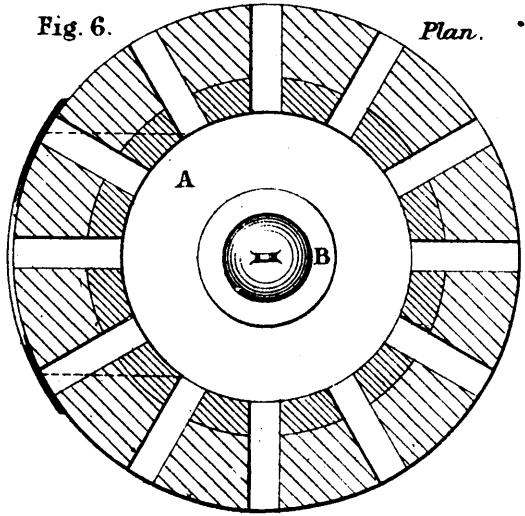

Fig. 6. *Plan.*



Roasting.

From the stamps the stamped ore is taken in small ore-cars to the roasting furnaces, which are double-bedded in design, one hearth being built immediately above the other. This type of furnace has proved, after various trials, to be that best suited for the treatment of the Bolivian silver ores, and is stated to have been found the most economical as regards consumption of fuel, and to give the least trouble in labour.

At the Huanchaca mines these furnaces cost about £100 each, and are capable of roasting from 2 to 2½ tons of ore in twenty-four hours, the quantity and cost of the fuel consumed being as follows:—

Bolivian Dollars at 3s. 1d.

Tola (a kind of shrub), 3 cwt. at 60 cts. . . 1'80

Yareta (a resinous moss), 4 cwt. at 80 cts. . . 3'20

Torba (turf), 10 cwt. at 40 cts. 4'00

Bolivian Dollars . . . 9'00 say 23s.

One man can attend to two furnaces, and earns 3s. per shift of twelve hours.

Probably no revolving mechanical furnace is suited to the roasting of these ores, as the operation requires to be carefully and intelligently watched; for it is essential to the success of the Francke process that the ores should not be completely or "dead" roasted, inasmuch as certain salts prejudicial to the ultimate proper working of the process are liable to be formed if the roasting be too protracted. These salts are mainly due to the presence of antimony, zinc, lead, and arsenic, all of which are unfavourable to amalgamation.

The ores are roasted with 8 per cent. of sale, or 400 lbs. of salt for the charge of 2½ tons of ore; the salts cost 70 cents or 2s. 2d. per 100 lbs. So roasted the ores are only partially chlorinised, and their complete chlorinisation is effected subsequently, during the process of amalgamation; the chlorides are thus formed progressively as required, and in fact it would almost appear that the success of the process virtually consists in obviating the formation of injurious salts. All the sulphide ores in Bolivia contain sufficient copper to form the quantity of cuprous chloride requisite for the first stages of roasting, in order to render the silver contained in the ore thoroughly amenable to subsequent amalgamation.

Amalgamating.

From the furnaces the roasted ore is taken in ore-cars to large hoppers or bins situated immediately behind the grinding and amalgamating vats, locally known as "tinias," into which the ore is run from the bin through a shoot fitted with a regulating slide. The tinias or amalgamating vats constitute the prominent feature of the Francke process; they are large wooden vats, shown in Figs. 1 and 2, page 360, from 6 to 10 feet diameter and 5 feet deep, capacious enough to treat about 2½ tons of ore at a time. Each vat is very strongly constructed, being bound with thick iron hoops. At the bottom it is fitted with copper plates about 3 inches thick, C in Fig. 1; and at intervals round the sides of the vat are fixed copper plates P, as shown in Figs. 3 and 4, page 361, with ribs on their inner faces, slightly inclined to the horizontal, for promoting a more thorough mixing. It is considered essential to the success of the process that the bottom plates should present a clear rubbing surface of at least 10 square feet.

Within the vat, and working on the top of the copper plates C, there is a heavy copper stirrer or muller M, Figs. 1 and 2, caused to revolve by the shaft S at the rate of 45 revolutions per minute. At Huanchaca this stirrer has been made with four projecting radial arms AA, Figs. 1 and 2; but at Guadalupe it is composed of one single bell-shaped piece B, Figs. 3 and 4, without any arms, but with slab-like arms fixed on its underside; and this latter is claimed to be the most effective. The stirrer can be lifted or depressed in the vat at will by means of a worm and screw W at the top of the driving shaft, Fig. 3.

The bevel gearing of the stirrer shaft is revolved by shafting connected with pulley wheels and belting, the wheels being 3 ft. and 1½ ft. diameter, and 6 ins. broad. The driving engine is placed at one end of the building. Each vat requires from 2½ to 3 H.P., or in other words an expenditure of one H.P. per ton of ore treated.

At the bottom of the vat and in front of it a large wooden stop-cock is fitted, through which the liquid amalgam is drawn off at the process into another shallow-bottomed and

smaller vat V, Figs. 1 and 2. Directly above this last vat there is a water-hose H, supplied with a flexible spout, through which a strong stream of water is directed upon the amalgam as it issues from the grinding vat in order to wash off all impurities.

The following is the mode of working usually employed. The grinding vat or tinia is first charged to about one-fifth of its depth with water and from 6 to 7 cwt. of common salt. The amount of salt required in the process depends naturally on the character of the ore to be treated, as ascertained by actual experiment, and averages from 150 to 300 lbs. per ton of ore. Into this brine a jet of steam is then directed, and the stirrer is set to work for about half an hour, until the liquid is in a thoroughly boiling condition, in which state it must be kept until the end of the process.

As soon as the liquid reaches boiling point, the stamped and roasted ore is run into the vat, and at the end of another half-hour about 1 cwt. of mercury is added, further quantities being added as required at different stages of the process. The stirring is kept up continuously for 8 to 12 hours, according to the character and richness of the ores. At the end of this time the amalgam is run out through the stop-cock at bottom of the vat, is washed, and is put into hydraulic presses, by means of which the mercury is squeezed out, leaving behind a thick pulpy mass, composed mainly of silver, and locally termed a "pina," from its resembling in shape the cone of a pine-tree. These "pinas" are then carefully weighed and put into a subliming furnace, Figs. 5 and 6, page 364, in order to drive off the rest of the mercury, the silver being subsequently run into bars. About four ounces of mercury are lost for every pound of silver made.

The actual quantities of mercury to be added in the grinding vat, and the times of its addition, are based entirely on practical experience of the process. With ore assaying 150 to 175 ounces of silver to the ton, 75 lbs. of mercury are put in at the commencement, another 75 lbs. at intervals during the middle of the process, and finally a third lot of 75 lbs. shortly before the termination. When treating "pacos" or earthy chlorides of silver, assaying only 20 to 30 ounces of silver to the ton, mercury in instalments of 36 lbs. to 2½ tons of ore at three different stages of the process as just described.

The rationale of the process therefore appears to be that the chlorinisation of the ores is only partially effected during the roasting, so as to prevent the formation of injurious salts, and is completed in the vats, in which the chloride of copper is formed progressively as required, by the gradual grinding away of the copper by friction between the bottom copper plates and the stirrer; and this chloride subsequently becoming incorporated with the boiling brine is considered to quicken the action of the mercury upon the silver.

Subliming.

The subliming furnace, shown in Figs. 5 and 6, page 364, is a plain cylindrical chamber A, about 4 ft. diameter inside and 4½ ft. high, lined with fire-brick, in the centre of which is fixed the upright cast-iron cylinder or bell B of 1 ft. diameter, closed at top and open at bottom. The furnace top is closed by a cast-iron lid, which is lifted off for charging the fuel. Round the top of the furnace is a tier of radial outlet holes for the fuel smoke to escape through; and round the bottom is a corresponding tier of inlet air-holes, through which the fuel is continually rabled with poles by hand. The fuel used is llama dung, costing 80 cents or 2s. 6d. per 250 lbs.; it makes a very excellent fuel for smelting purposes, smouldering and maintaining steadily the low heat required for subliming the mercury from the amalgam. Beneath the furnace is a vault containing a wrought-iron water-tank W, into which the open mouth of the bell B projects downward and is submerged below the water. For charging the bell, the water-tank is placed on a trolley; and standing upright on a stool inside the tank is placed the pina, or conical mass of silver amalgam, which is held together by being built up on the core-bar C fitted with a series of horizontal discs. The trolley is then put into the vault, and the water-tank containing the pina is lifted by screw-jacks, so as to raise the pina into the bell, in which position the tank is then supported by a cross-beam. The sublimed mercury is condensed and collected in the water; and on the completion of the process the tank is lowered, and the spongy or porous bone of silver is withdrawn from the bell. The subliming furnaces are ranged in a row, and communicate by lines of rails with the weigh house.

ON DOMESTIC ELECTRIC LIGHTING.

BY W. H. PREECE.

I have now to deal with a question which I think will appeal to you more than the technical subject I have so rapidly run through, and that is the question of domestic electric lighting. I am rather surprised to find that in Canada, so far as I have observed, there is no single example of a private house being lighted by the aid of electricity. One instance, by-the-bye, Professor Bovey tells me of, though he did not mention where it is. Our experience of electric lighting in England is rather limited. The first person, I believe, to take the bull by the horns and settle the question of applying electricity to house lighting was that gentleman whose name has cropped up every time we have had occasion to speak, I mean Sir William Thomson. He fitted up his house with the light, and his example has inspired several others. Amongst others I have taken the matter in hand, and I could not do better than describe on this occasion exactly what I have done in this direction. As I remarked, we are backward, generally, as to this subject in England. We cannot get electricity supplied at our doors. We look forward to the day when we shall be able to have it delivered in some form or other, like you have your ice delivered at your doors every morning out upon your doorstep, though not, as some one suggested, in the form of secondary batteries. I do believe that the day is not far distant when electricity will be supplied at our doors just like water and gas are at present.

I want to find out the expense, the difficulty and the trouble involved. To do this I obtained estimates, and calculations of the cost; but these, though honest, are very often not reliable, and you all know that figures may be twisted anyhow.

I am lighting up my house with gas, but I am burning that gas in my garden, and extracting from it that which I want, namely, light, and am discharging into the air of my garden that which I do not want, namely, poison. I want to explain this. It sounds magical, but it is a simple fact. In my garden I have built a pretty little engine-house, in size only 18 feet by 10, and in that house I have fixed a two horse gas engine. In this gas engine my gas is burned, and instead of being burned in the form of light it is burned in the form of power. That gas engine rotates a dynamo, and that dynamo machine produces a current of electricity. It is a small Gramme dynamo machine weighing two hundredweight, and it gives me ample current for my purpose; in fact the current I get is 36 amperes with 42 volts. And I get from my two-horse gas-engine 1,512 Watts, that is just a little more than two-horse; so that the efficiency of my gas engine and my dynamo is good indeed. Now this current which is produced is thrown into secondary batteries. I have gone back to the original form of secondary battery invented by Planté twenty-five years ago, which consists of lead plates (two, square) fitted opposite each other in a solution of sulphuric acid. I have seventeen cells. On my gardener going to duty in the morning he starts the gas engine; that engine works from about 9 till 1, and it puts into those secondary batteries sufficient electricity to supply me the whole of the next evening and the next night. Electricity is directed into the house by means of thick copper mains coated with India-rubber. Lamps are fixed in every room, just where they are wanted.

My house is not fitted up with the idea of making a show, but so that I can get exactly what light I want, and get it in the place where I want it. The lamp fittings are extremely ingenious; the most beautiful, indeed, of the machinery. The fixtures are on the movable principle, after the design which Sir William Thomson has introduced; but there are also little movable lamps which enable me to go to my wine cellar, or to search under any bed, or in any dark corner of the house, and go round the garden with a portable lamp. When carrying it I pay out a wire that carries the electricity, which is just like a fishing line. You know how easily that can be paid out and wound in. I have done more than that. I have indulged in the luxury of supplying my little girl with a very large doll's house of four rooms, each room nicely furnished and populated with well-dressed dolls, and each of these rooms has a little electric light of its own.

I have brought with me one of these tiny electric lamps, and will endeavour to show you one of them alight. [Mr. Preece then, amidst considerable applause, with the aid of batteries supplied to the platform, connecting with them a wire in his hand, which was attached to his scarf pin, at a given moment

produced a blaze of electricity on his scarf, and as quickly disconnected and reconnected it.] I show you in the interest of science, and for the welfare of those who think of applying electric lighting to their houses.

This same idea of using the electric light for general purposes is carried out to a large extent in our theatres and different places, and last year when I visited Vienna I had my scarf thus fitted up with one of the tiny lamps; and it attracted a good deal of attention. I have astonished many people with it at different times; sometimes I have worn it as a button-hole, and have frequently attached it to the heads of my lady friends as a coronet.

Now all these things show how easily and readily electricity can be applied to various everyday-life purposes. In my house I use lamps that require only 30 volts to keep them going, with safety from shock and fire. I often put the wires into the mouths of my little children in order to illustrate practically to my guests that there is no danger. They do not much like it, but it does not hurt them.

At the door of each room is a little switch that you can turn and produce a light in the room before you enter, thus requiring no match or other assistance. When you go out of the room you turn the handle again to extinguish the light; thus you only make the lamp consume electricity when you really want it. This is naturally a great economy.

Many people say that this light costs twice or three times as much as gas. But you must remember that you only use it one third or one half of the time that you use gas, by economising in the way I have mentioned. Therefore, perhaps, gas comes to about the same thing.

I have instruments about my house that enable me to tell the condition of the batteries, the amount of my current and exactly what is going on; in fact up to the present moment I have really had no difficulty whatever. It has been, of course, a hobby for some months. I have left the house in charge of my sister, who was rather timid for the moment in regard to using the electric light, and I set the question at rest by taking away all the gas fittings and leaving her nothing else, and now in my absence here in Canada I have recently received a letter saying she has had no trouble about it yet.

As regards the expense, I have not studied economy, my desire first being to secure efficiency, and I have done all I could to illuminate the house thoroughly. My expense, therefore, is no criterion. I estimate that a house like mine can be fitted in all its details for about £7 10s. per lamp. I do not think I shall spend more than I have been spending for gas. I know I shall not consume so much of the gas, but I pay the gardener a little extra wages for his trouble, and I spend money in cotton waste and oil, but the result will be that the extra outlay will represent a mere fleabite compared with the luxury I get, which amply compensates one for expense and trouble incurred.

I have come to one or two conclusions on this matter. The first is, that until we can get electricity supplied to our doors, we must look upon electric lighting as a luxury, and should be prepared to pay for it as such. But as a luxury, it is nothing compared with the cost of a carriage, or with one's wine bill. The next thing notable is the steadiness and charm and comfort of the light; the durability of decorations, which are not injured by the electric light; the absence of heat and of destructive gases; the non-vitiation of the air, and the longer life one gets. I shall live three or four years longer with the electric light than I should with gas, and all these things make up a splendid result for any amount of money you may spend.

There are difficulties, of course, which will bother any untechnical person; but when we have investigated and once overcome these matters others will be able to follow in our steps and obtain some of the advantages and benefits that we do. You only require to use the electric light when you want it, and you thoroughly appreciate it. I am myself wakeful at night, and especially if I have indigestion. Supposing I want a light to obtain a book or a paper I simply touch a button and my room is at once bathed in a delicious light; having obtained what I want, I touch the button again and out goes that light. Once more, there is no danger from fire. All the trouble and difficulties exist in the matter of distribution. When we succeed in getting central stations for the distribution of the electric light, difficulties will cease and troubles will be infinitely less than we experience in the case of gas.

In London the progress of the electric light has been checked by the most unfortunate Act of legislation which the Government has committed for some time. In 1882 our English Par-

liament passed an Act restricting the operations of the light, and practically checking its progress. In fact it has put a damper on this enterprise which I do not suppose we shall get over for years. At the the same time there are notable experiments being tried. At Colchester, in Essex, they are establishing a central station, and they are going to do the same thing on a small scale in London. There are also one or two other cities which contemplate the plan. I think, in fact, that London would have been lighted by this time with electricity but for the unfortunate Act to which I have referred.

Sir William Thomson remarked: I have listened with great interest to Mr. Preece's remarks about electric lighting, and I endorse fully what he said as to the pleasantness and the healthiness of it in the house. To those who would carry out the system of lighting private houses, large country houses, and the like, at great distances from towns, where central lighting cannot be obtained, are particularly available. The question of expense takes a different position from that in the town, if the house is in the neighbourhood of water-power. Electric lighting will then be an economy. Sir William Armstrong produces the light at his house at Craigside from a waterfall about one and a-half miles distant. Nothing can be more satisfactory than the result. I wish to point out the vast natural advantages which American cities enjoy in regard to water power at their disposal. Here in Montreal you have the Lachine Rapids within five miles. The problem of making use of that power is easy enough from an engineering point of view. The electric light might easily be transmitted hither by means of a copper wire. It is only where the power at the working end is costly, as with steam power or expense of fuel, that the difficulty is very serious from an economical point of view. With such abundance of water as you have, half the power might be wasted, and yet a good economy realized on the whole. It is unfortunate that legislation in England has not encouraged, but has rather been an obstacle against house-to-house lighting hitherto. Sir F. Bramwell has during the meetings expressed himself warmly, but not more warmly than the occasion demands on this point. England, however, will not, I think, be kept long back by obstructive legislation. I hope that legislation will soon be modified to meet the prevailing wants, and that the true economy of the light will be found out in practice. In Mr. Preece's first paper it was shown that 30 times as much expenditure of energy took place in a gas flame as in an incandescent lamp with the same amount of light. With such a vast difference I cannot doubt that the electric light has a good future before it, and that incandescent lighting will become general, wherever a sufficient number of houses can be grouped together. Say we have a place that wants a machine of some 5,000 or 6,000 light-power. From a central station in that case you use the light economically, for then at double the cost of gas it would be a positive economy if the ordinary gas lamp is kept burning the whole of the night, seeing that gas cannot be out and lighted again as the electric light may be in anything like reasonable time. The proportionate cost of electricity to gas is, I think, about two to one; and in view of this a central system, enabling a person to pay according to the time the light is used, would be an economy compared with gas. You may add the great advantage secured with respect to your decorations, your ventilation, and your health. The balance, then, will be rather in favour of electricity. I hope the discussion may end in promoting a great national object in the application of science for the benefit of all mankind. (Applause.)

Dr. Friendervelt described a photographic gallery in London, where gas was used for the development of the electric light, a dynamo being worked by a gas engine placed in the cellar. The negatives were printed off by the aid of the electric light. The convenience of this he need not dwell upon.

Prof. Forbes said: I think we all have to thank Mr. Preece heartily for his address. His subject is one of much interest for this meeting at Montreal, because I must say that I have felt astonished that during the whole time we have been in Canada we have not seen a single incandescent lamp, except that just now noticed in Mr. Preece's scarf. (Laughter.) Really the whole subject of domestic lighting seems to have been neglected in Montreal and in Canada generally. The interest of this city ought to be awakened to the remarkably favourable conditions under which it is placed, owing to the fact of having such an unlimited water power at its disposal at nominal expense. I would draw attention to the fact stated by Sir William Thomson, which may have struck some people here, that it is a serious matter to take up electric lighting if

its cost may amount to something like double the price of gas. I can understand many people saying that it is an enormous outlay to pay in Ottawa and Quebec treble the cost of our gas in Montreal, that is, 3 dollars 40 cents. But two things should enter into your calculations. One is the enormous price of gas here, and the other the infinitesimal price of water power. We find in England that with gas at 3s. per 1,000 feet, the electric light can almost compete with gas on a large scale. If we used water power we could considerably surpass the gas in economy. If then, we can do that, and when we come out here and find gas at 3 dollars per 1,000 feet, it is perfectly clear that with such ample water power it is only a question of the time within which the electric light will be introduced into every one of your cities. (Hear, hear.)

Mr. Carpenter described some experiments made by a friend of his at Hawick, in the south of Scotland, who had an advantage which Mr. Preece had not. He had built a new house and fitted it up 5 miles out of the town of Hawick. He went into the question of the relative cost of gas and electricity for lighting purposes. Through the grounds of his house there runs a small stream falling into the Teviot. He dammed this little stream, which never runs dry, and there he got a fall of 25 feet. The lake, moreover, which he thus made improved the appearance of his grounds. At the foot of the fall thus obtained he erected an American turbine with a dynamo machine attached. He led the wires in and fixed 90 lamps. The cost of all this was very considerably less than that of bringing out gas from the town. The total cost amounted, not as in Mr. Preece's case, to £7 per lamp, but to a very little over £4; the total estimate being a little over £360 for the 90 lamps. This installation was started last Easter. I had a note from him a few days ago, in which he said that he never had the smallest difficulty. My friend decided to be master in his own house, and he had an arrangement by his bedside so that when he retired he could not only cut the lighting off, but he could save his water-power, for it was simply necessary for him to send a current from his bedside to the sluice half-a-mile off, and that allowed the water to accumulate till the next day. A somewhat similar arrangement was laid down by Mr. Hammond in Highgate. He lives at the top of the hill, and is not so fortunate as to have water-power at his command. He has laid down a gas engine in one of his houses. Gas is tolerably cheap there, and his experience was this, that if he spent 300 cubic feet of gas on his engine, and measured the amount of light produced, he would have had to burn 400 cubic feet of gas at the burner for the same lighting effect. This illustrates a comparison between gas and electric lighting. When gas lighting first came in people insisted on having a much greater quantity of light than they had had from the old oil lamps, and they paid more for it. Precisely the same thing has happened in England as to electric lighting. One reason of its heavier cost is that people insist on having more light. At the conference of the Society of engineers a good deal was said on this aspect of the matter. I may add that neither in Boston nor New York could I hear of any incandescent lighting.

Sir F. Bramwell testified that Mr. Preece had by the aid of the gas engine and secondary batteries lit up his house to absolute perfection. His house was old-fashioned, with a charming dining-room, but too low according to our modern ideas. That room was lit with four lights when some dozen of guests were gathered round one evening, and the appearance of the table was all that could be desired. There was not the slightest fluctuation in the light, and the temperature was not more than that outside. There was no necessity in Mr. Preece's system of any permanent light outside. When they left the house a light flashed out and bade them farewell. Nothing could be imagined more complete or charming. As to the gas question, he had experimented one whole day at the Royal Institution, with the result that the amount of gas for the motive power of a gas engine would not give an equal amount of light as an illuminant. But the point was not can electric lighting be as cheap as gas? but can it be made as cheap to persons who value their furniture and health, and who now can pay for wax candles and good lamps? If it could be made cheap to that class there were a large number in London who would be glad to use it. There was no doubt that the development of electric lighting had been checked by the legislation which had been referred to. He hoped that some day people would come to their senses. The present Act said that at the end of 21 years they should have to part with the rights they had. They got nothing based on prospects, but simply the value of the materials then existing. He could not believe that

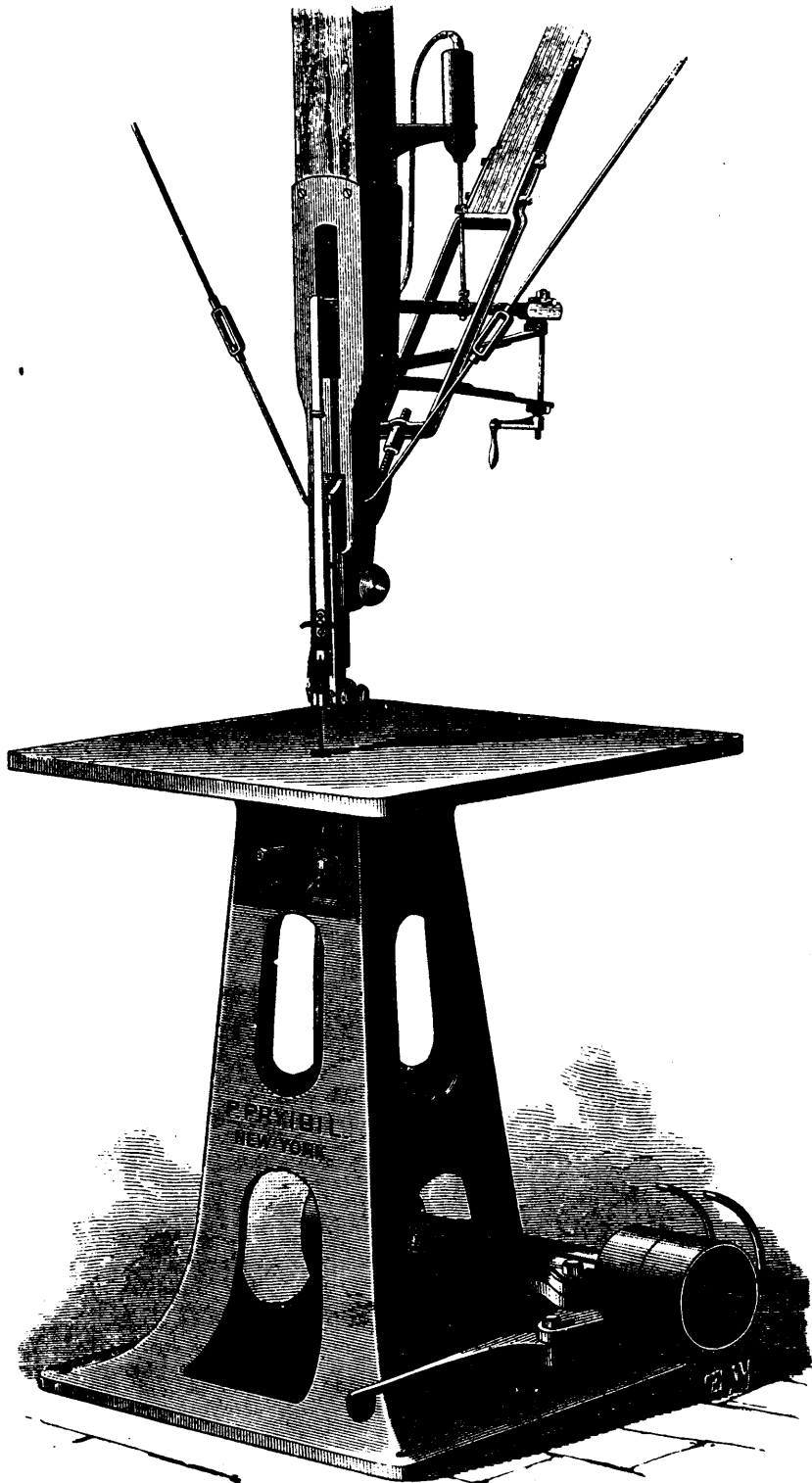

JIG SAW MACHINE.

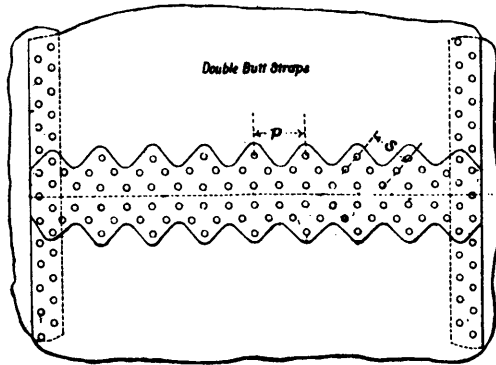

IMPROVED BOILER JOINT.

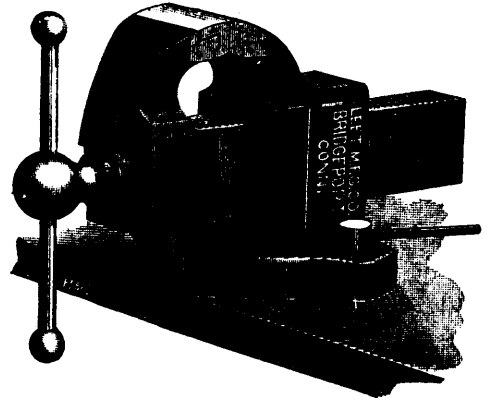
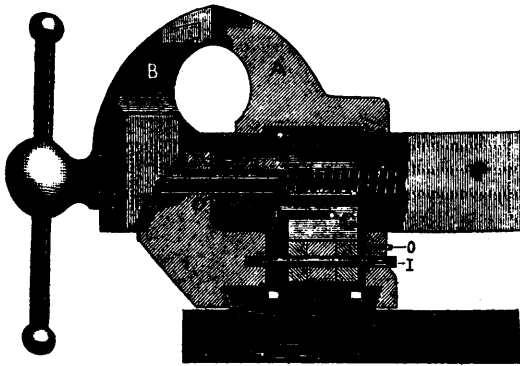

SLIDING JAW BENCH VISE.

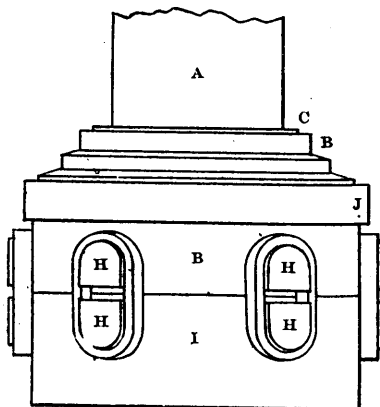

FIG. 1.

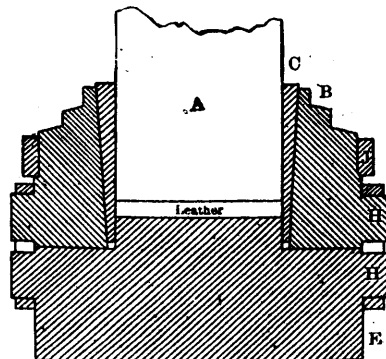

FIG. 2.

HAMMER-HEAD AND DIE.

that injustice would be allowed to continue. It might be that the delay in electric light development would be advantageous, because improvements might be made in the interim. If electric lighting only had had fair play it would ere this have been largely used in the best parts of London as a luxury.

Mr. Preece, in responding, said:—In answer to the question how do I store electricity for my pin? I may say that I do not store it at all. No more ridiculous term than that could be employed. I use a secondary battery. The only instance I know of where electricity is stored is the case of a Leyden jar or condenser. What is stored, if you use the term, is energy; that is, we put something into the battery and take it out again; but it is not electricity. As to my arrangements, I mean in future to use my engine on Monday only, for the purpose of doing what is described by the misnomer of "storing" electricity. It will charge the batteries, which I shall have big enough to give me sufficient power for the rest of the week.

N.B.—A paper read before the British Association at the Montreal Meeting.

AN IMPROVED JIG SAW.

The saw illustrated on page 363 shows a very superior machine for all kinds of inside and outside sawing. By a peculiar arrangement of the spring fulcrums, the tension of the saw is maintained uniform throughout all parts of the stroke; and by a hand screw the springs which are of steel, can be adjusted to any desired tension, or, when not in use, wholly relieved.

The lower cross head is fitted with dog wood faces, the end grain forming the bearings. This, by coming saturated with oil, is rendered self-lubricating and never gives the trouble incidental to the use of metal slides, which the sawdust quickly deprives of all the oil which can be put on them.

Both upper and lower slides are provided with adjustable gibs, and the lower slide and its connections are contained in a recess cast in the face of the body. The reciprocating parts are thereby brought within the frame and the machine rendered very steady.

The saw guide is held upon an adjustable slide which enables it to be set close to the work, the belt shifter is provided with a brake which stops the machine the moment the belt is shifted to loose pulley, and the machine is furnished with a blower which keeps the work clear of sawdust.

The table is of iron, and the loose pulley is self-oiling.

Tight and loose pulleys, 7 inches diameter, for 2 inch belt. Speed, from 900 to 1,100 revolutions per minute.

This saw is manufactured by P. Prybil, 461 467 West 40th street, New York city, where further information as to price, etc., may be obtained.—*Ex.*

THOM'S IMPROVED BOILER JOINT.

We illustrate on page 369 a new form of boiler joint invented by Mr. John Thom, of 8, Storey-square, Barrow-in-Furness. The engraving shows the arrangement so clearly that very few words of explanation will suffice. The lines of rivets form zig-zags or vandykes, and the edges of the covering strip are cut to a corresponding contour in order that they may not spring away from the plate when caulked. This disposition of the rivets permits of the minimum of reduction of the cross section of the plate, the number of rivet holes in the outer row, where the plate encounters the maximum strain, being only one-half of that of the inner rows. The joint has a strength equal to about 90 per cent. of that of the solid plate, and by its use a saving of 15 per cent. of that of the weight of plates can be obtained with equal strength. It has been passed by the Board of Trade for some boilers now building. The following are the formulæ by which the strength is computed:

- Let t = Thickness of plate.
- S = Pitch diagonally,
- p = Pitch of rivets (greatest),
- d = Diameter of rivets,
- a = Sectional area (one rivet),
- n = Number of rivets in $p=5$,
- 1.75 = For rivets in double shear,
- $\frac{2}{3}$ = For steel plates and steel rivets.

$$\text{Percentage of plate to solid plate} = \frac{p-d}{t} \times 100.$$

$$\text{rivets} = \frac{n \times a \times 1.75}{p \times t} \times 100 \times \frac{2}{3}$$

$$S = \frac{6}{10} p + \frac{4}{10} d + d.$$

Lap joints can be made in a similar manner.

SLIDING JAW BENCH VISE.

We illustrate on page 369 the latest improvement in bench vises, devised by Wm. H. Northall, and manufactured by the Leet Manufacturing Co., of Bridgeport, Ct. This is a sliding jaw vise with swivel bottom, so designed as to slide to the required opening and then grip its work securely or to be used like an ordinary vise. The screw is novel in that the thread is square on the strain side, flat on top and beveled at back, thus permitting a finer pitch and more powerful grip with a thread of strongest form. The screw works through a split nut which opens or closes by turning to the left or right and becomes practically a jam nut under strain, thus obviating any tendency to slip or loosen under the severest tests.

In turning the lever to the left, the pawl E drops into the spline of the screw and rotates the cam sleeve D , which forces the wedge and locking device H back, opening the nut G , thus allowing the sliding of the jaw B . In turning the lever to the right a spring forces the wedge and locking device H back into position, thus closing and locking the nut. Turning in the small screw O locks the nut permanently, and thus transforms the vise from a sliding jaw to a common screw vise. By means of the capstan screw, shown at the base, the vise may be swivelled in any direction and locked with facility.

The vise, as a whole, seems to provide for as many adjustments and conditions of work as is possible without undue complication.

A NOVEL HAMMER-HEAD AND DIE.*

In the ordinary construction of steam hammers the head and die are usually secured to the piston-rod, which is slightly tapering at the end, by means of keys applied to a slot in the connection between the piston-rod and head, and a dovetail joint in the connection between the head and die. The objection to this and all other modes of connection by means of keys is, that the unequal expansion and contraction of both the head and die continually knocks the keys loose—no matter how tight they may be driven—necessitating frequent stoppages to tighten up, which are sufficiently annoying in themselves even if they do not lead to more serious consequences, such as the bursting of a head or cracking of a die; and, although these parts are generally made of cast-steel such events are not of uncommon occurrence, especially in shingling, where foul blows are frequent.

The device which I present to your notice in this paper was applied a few years ago to a Sellers hammer in the works of the Trenton Iron Co., and has effectually overcome the difficulties mentioned, being a much cheaper as well as better arrangement.

Referring to the sketches (Figs. 1 and 2, page 369), A , is the piston-rod; B , the head secured to the lower extremity of the piston rod by means of a tapering split ring, C , and a circumscribing wrought-iron band, J . E is the die. H, H' are a series of lugs projecting radially from the exterior face of the lowermost portion of the head, and H', H' are a corresponding series of lugs projecting similarly from the exterior face of the uppermost portion of the die. The two series of lugs in the set of the parts are so disposed as to be vertically aligned in corresponding pairs.

The parts are joined in the following manner:—The wrought-iron band J , is first shrunk upon the head B , to keep it from fracturing, and the head, with the band shrunk upon it, is then heated to a red heat. The tapering sleeve or ring C , which is split like a piston ring, is now slipped over the end of the piston-rod; the head B while red-hot placed around this; and the die placed so that the lugs on it come directly opposite those on the head. The tapering ring C is then driven down tightly with a sledge; the head left to cool; and finally, the bands shrunk around the lugs as shown in the

* A Paper read before the American Society of Mechanical Engineers, Nov. 5th, 1884, by Wm. Hewitt, Trenton, N.J.

sketches. The opposing faces of the lugs are faced off or bevelled so that they do not touch in the contact of the die with the head, in order to provide against the possibility of their receiving or sustaining any portion of the shock from the blows of the hammer, which otherwise would break or destroy them. The bands around the lugs in shrinking are of course subjected to an enormous tension, which retains them fixedly in position and holds the die immovably in place, until it is worn out, when it is removed by cutting the bands and replaced by a new die. The head *B* on cooling shrinks sufficiently, as practice has proved, to prevent the tapering ring *C* from slipping or shaking loose. A leather washer is placed between the end of the piston-rod and die, to provide for a slight amount of elasticity and ameliorate somewhat the force of the severe blows. The tendency of the blows, it is obvious, is to drive the tapering ring in tighter, and the force thus exerted outwardly against the head is so great that it would soon break it if it were not for the wrought-iron band *J*, which effectually prevents this. The head and die are made of cast-iron.

GOOD MORTAR.

Machinists and engineers who use mortar, will value the appended information: Good mortar is a solid silicate of lime, that is, the lime unites with the silica or sand to form a silicate of lime. In ancient days those who had some conception of the way the two things united superintended their mixing; but nowadays anybody is supposed to know how to make mortar, while nobody knows much about it. Dry lime and dry sand laid together or mixed and kept dry for a thousand years would not unite to form silicate of lime any more than acetic acid and carbonate of soda dry in a bottle would effervesce. To make silicate of lime just as good as was made by the Romans, all that is necessary is to proceed intelligently; procure good caustic, i.e., fresh-burned lime, and if you find it all powder, i.e., air-s'aked, don't use it; use only clear lumps. Slake this, (if possible in a covered vessel), using only enough water to cause the lime to form a powder. To this while hot add clean sand, not dirt and loam called sand, but sand—and with the sand add enough water to form a paste. Then let it lie where it will not become dry by evaporation—in a cellar, so much the better, for as soon as you have mixed the sand and lime as above, they begin to react one on the other, and if not stopped by being deprived of moisture will go on reacting until silicate of lime (as hard as any silicate of lime ever was) is formed. But, if you take this so-called mortar as soon as made and lay bricks with it, unless the bricks are thoroughly wet you stop the formation of silicate of lime, and might as well lay your bricks in mud. Lime and sand, after being mixed, might lie two years with advantage, and for certain uses, such as boiler setting, or where the whole structure of brick and mortar is to be dried, the mortar ought to be mixed for one year before use, and two would be better; but for house building, if the bricks are so wetted as not to rob the mortar of its moisture as soon as used, mortar that has been mixed a month will form good solid silicate of lime among the bricks it is laid with in ten years, and will be still harder in a hundred years. The practice of mixing mortar in the streets and using it at once is as foolish as it is ignorant, and would be no improvement. Silicate of lime is made only by the slow action of caustic lime and sand, one on the other—under the influence of moisture. Dry they will never unite, and mixing mortar as now mixed and using it at once, so as to dry it out and stop the formation that the mixing induced, is wrong.

Miscellaneous Notes.

EXPLOSIONS FROM SUPERHEATED WATER.—An extended series of experiments and a study of the records of such phenomena has convinced Hirsch a French engineer, that there is evidence that boiler explosions have been caused by superheated water. If they occur at all, the instances are very rare and from a combination of circumstances seldom observed, not well understood or clearly defined. The conclusions have been reported to and adopted by the Commission Centrale des Machines à vapeur.

POSITION OF THE POLES OF MAGNETS—Messrs. W. Hallock

and F. Kohlrausch have made a number of experiments on ordinary long bar magnets in order to determine with exactitude the true position of the poles in the length of the bars. Fourteen magnets were used, some of various conditions of hardness, and in general they were in the form of steel cylinders magnetized in the direction of their axes. Their results, taken in connection with those of Schneebeli and Helmholtz, agree in showing that the effective poles of a magnet are about one-twelfth of the distance of the length from the ends. This result is, according to the observers, in all probability correct to within five per cent.

ARTIFICIAL RAIN-STORMS.—Among the latest inventions reported from Australia is a machine for producing rain-storms. It is intended to force a rain supply from the clouds during a period of drought. The apparatus is in the form of a balloon, with a charge of dynamite attached underneath it. The balloon is to be sent into the clouds, and when there the dynamite is to be fired by a wire connecting it with the earth. A trial of this novel contrivance is to be given upon the dry districts of New South Wales, and the result is looked forward to with interest by some of the residents of that colony. If the machine is a success, perhaps the Australian fire underwriters may employ it with benefit to wet down the arid districts in that country and reduce the losses by fire.—*Insurance Chronicle.*

A VARNISH has been patented in Germany for foundry patterns and machinery which, it is claimed, dries as soon as put on, gives the patterns a smooth surface, thus insuring an easy slip out of the mould, and which prevents the pattern from warping, shrinking, or swelling, and is quite impervious to moisture. This varnish is prepared in the following manner: Thirty pounds of shellac, 10 pounds of manilla copal, and 10 pounds of Zanzibar copal are placed in a vessel, which is heated externally by steam, and stirred during four to six hours, after which 150 parts of the finest potato spirit are added, and the whole heated during four hours to 87 d-g. C. This liquid is dyed by the addition of orange colour, and can then be used for painting the patterns. When used for painting and glazing machinery, it consists of 35 pounds of shellac, 5 pounds of manilla copal, and 150 pounds of spirits.

THE STEERING OF BALLOONS.

M. Duroy de Bruignac has brought before the French Academy of Sciences some theoretical considerations with respect to the steering of balloons, which have a special interest at the present time. One important condition to be fulfilled is the approximation of the centres of traction and resistance in order to diminish the perturbing moment of the vertical stability. It is probably because this condition was not quite fulfilled that MM. Renard and Krebs, in their balloon ascent at Meudon, experienced on "several occasions" oscillations of 2 deg. or 3 deg. of amplitude. A still more important consideration is that of resistance to progress caused by the air. A simple calculation shows that the resistance of the air to the translation of a balloon is proportional to the cube of the sine of the angle of incidence of the relative air-current or wind. Consequently, for small angles, which are those naturally adopted, a variation of angle from 2 deg. to 4 deg. nearly doubles or triples the resistance. This is a fact which ought always to be borne in mind; and it becomes advisable, not only to bring the centres of traction and resistance near each other, but to make them actually coincide. This last condition will be somewhat difficult to carry out, but it is not impossible to do so. If with one aërostat it is very difficult it will be much more easily done with two parallel ones. With proper attention to this matter M. de Bruignac thinks that aeronautics will at once enter on a practical phase, even with motors less efficient than those which have been known for some years past.—*Engineering.*

EARTHQUAKES.—(Nature.)

Most of those observers who have undertaken the detailed study of a region severely injured by an earthquake are well acquainted with the difficulties that attend on

such a perilous and unthankful work as examining the ruins. The necessity is soon felt for some means of accurately registering the various characters of the earth's movement. The imperfect record of the features of an earthquake afforded by broken walls, fissured roofs, and overturned objects is dependent upon a variety of causes.

1. The earthquake consists of a series of movements that do not radiate from a mathematical point, or even from the focal cavity, with perfect uniformity.

2. The group of disturbances which constitute a shock (of variable duration) may not arise from the same point, as, for instance, in the rending of a fissure in an upward direction, the first impulses would be derived from a much lower point than the last.

3. The great variation in the physical qualities of the rocks traversed, dependent upon their composition, intimate structure, and mode of arrangement. Also we may here include the irregular conformation of the surface.

4. The want of homogeneity and of regularity in the structure of houses and walls, and also the presence of door and window openings.

5. The presence of old fissures in buildings, either the result of displacement, shrinkage, or former earthquakes.

Were it possible to construct absolutely perfect instruments for registering the complex movements of an earthquake, we should be able to exclude the two important causes of error coming under the heads (4) and (5), but the others can never be removed, unless that under head (3) might be so by a complete knowledge of the subterranean geology of a district in question—a far from easy matter.

After perusing the recent paper by Prof. J. A. Ewing on "Measuring Earthquakes" (*NATURE*, vol. xxx. pp. 149 and 174), one might despair of ever understanding the complex tracings the author obtained. A more careful consideration of the subject would seem to help us out of the difficulty to a considerable extent in so far as theoretical reasons will permit us, and it is not till suitable seismographs have been fairly tried in other districts than the unsuitable alluvial plain of Yeddo that we shall learn whether there is any practical use in instrumental observation of earthquake movements.

In an alluvial plain like that of Yeddo, reposing as it probably does on the irregular surface of different but more elastic rocks, from which are transmitted to it the vibrations, the condition is such that a number of waves would be reflected and refracted so as to meet each other at various angles interfering with each other and producing very complex results on any pendulum instrument.

I am personally neither acquainted with the geology of the region in question nor with the type of disturbances constituting its earthquakes, yet from descriptions of the latter one would feel inclined to regard them as the tail-end movements of powerful shocks far below the surface, conditions highly favourable to complexity from reflection and refraction. Besides, the incoherent alluvium, often water-logged, is subject to a remarkable disturbance when vibrations are communicated to it from without, as may experimentally be illustrated by spreading jelly, or, better, mud, over the irregular surface of a piece of wood and tapping with a hammer.

These remarks may at first sight appear beyond the question, but we must not leave the subject without further trial. Any one who has studied the injuries resulting from destructive earthquakes such as that of 1857, described in Mallet's classical memoir, or of those of 1881 and 1883 in Ischia, cannot but be struck with the regularity of the injuries when the observer carefully excludes the large number of modifying influences, as heterogeneity in structure of buildings or the surface configuration of the point in question.

The following instruments were suggested by the study of the two great Ischian earthquakes, and with suitable modifications might be made appropriate to study small or great shocks as the case might require. The use of a pendulum as the main part of the mechanism has many objections, which have often been pointed out, and I think that future investigations will strongly confirm such

opinions. Nevertheless I have given examples where the pendulum may be used, or replaced by other methods employing the same type of registering apparatus (Fig. 1). a is a pendulum with preferably a pear-shaped bob of great weight, which has attached to its lowest point a strong plaited thread of dentist's silk, e , which passes through a perforated glass plate, d . The hole in the glass plate is smoothly drilled of the exact size of the silk thread, so as to allow it to run easily but no more; it has its lip smoothly rounded off so that a section of the edge (see d') is semicircular. The glass plate is firmly gripped by the horizontal metal plate c , which is rigidly fixed to the supports b , which in their turn are embedded in a solid masonry or rock basement. The silk thread is connected by a light wire cage, f , to the cylinder g , which slides easily up and down the fixed triangular column h . The cylinder g is connected to the writing arm lever i , which

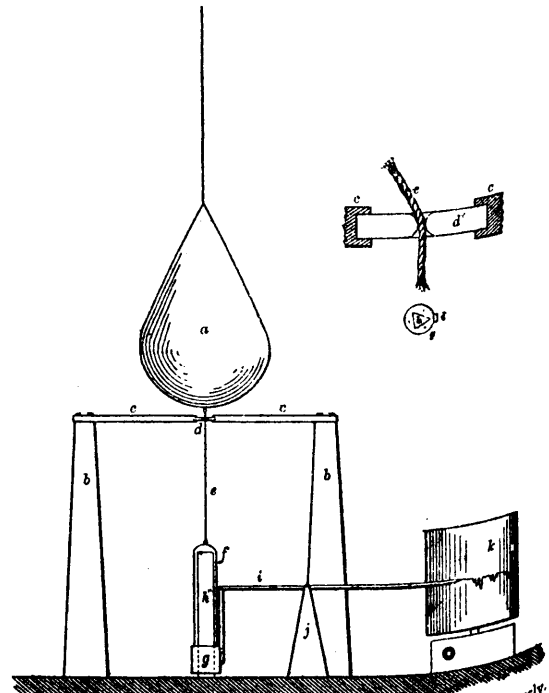

FIG. 1.—Pendulum apparatus to register amplitude of wave continuously.

may be short, and write directly on the recording drum k , being then a simple stylus, or, as in the figure, arranged to magnify the amplitude two or more times at choice.

When any earth-movements take place, the relative horizontal swings of the pendulum are converted into vertical movements of the silk thread, cylinder, and stylus, which on a time-ruled recording sheet will give accurate amplitude tracing minus the friction of the apparatus, which, if well constructed and the pendulum proportionally very heavy, may be excluded. By using a heavy pendulum with short suspension we may measure oscillations of short period, or, by using a long suspension and a delicate apparatus with greatly magnifying lever, this apparatus might be a useful tromometer, or measure of slow earth oscillations or tiltings (Fig. 2).

Three solidly-fixed cast-iron uprights, a , support a circular massive cast-iron plate, b , which has a conical aperture at its centre. Resting upon this is a circular sheet of plate-glass drilled at its centre in the same manner as the silk thread perforation in Fig. 1, as it serves a similar

purpose. This glass plane must be perfectly horizontal. A circular disk of lead, *g*, is inclosed between glass planes, *d*, and rests on three perfect spheres, *f*, which should be preferably of glass or ivory. Rigidly attached at its centre on the lower side is a conical spire, *m*, whose point reaches just the level of the glass plane *c*, and has fixed to it the silk thread *n*. From the centre of the upper side

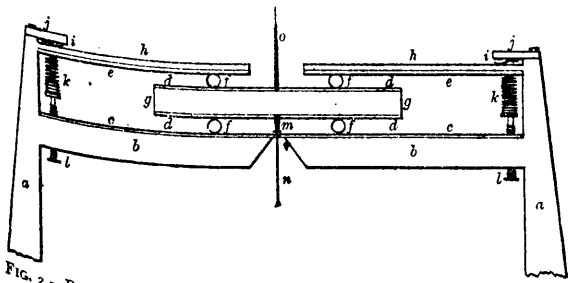

Fig. 2.—Ball and plane seismograph for indicating amplitude and azimuth in all phases of a shock.

projects the steel stylus *o*, bearing a fine platinum wire at its extremity, which may be used with the double azimuth circle of Fig. 3 in a direct manner in case of large earthquakes, or by a lever supported in gimbals, as also in Fig. 3. Another glass plane, *e*, with a large circular aperture at its centre for the free movement of the azimuth stylus *o*, has a wrought-iron trellis work backing *h*. This reposes on the springs *k*, which are regulated by the

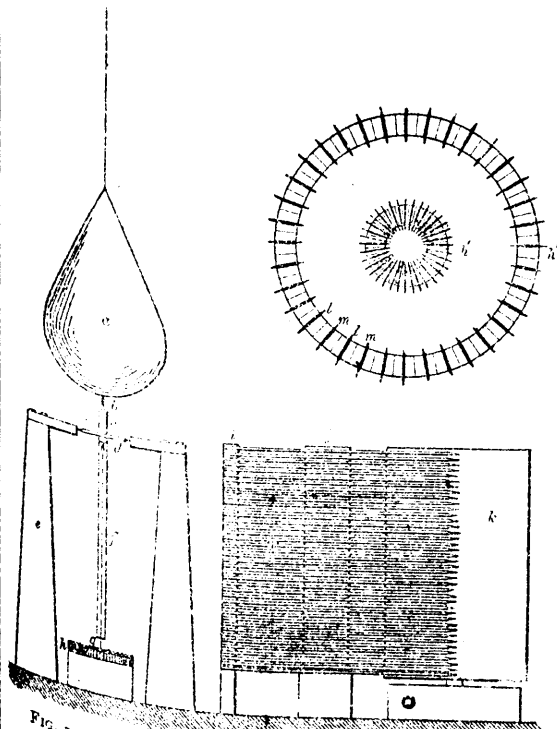

Fig. 3.—Azimuth register of wave path in all phases of an earthquake.

milled-head screws *l*, so that it is only pressing sufficiently on the upper balls *f* to keep them in place. The upper springs *i* are introduced to allow slight freedom of motion to prevent breakage of the plates in almost vertical shocks or from the expansion of the lead disk, balls, &c. The silk thread is connected to the registering apparatus in the same manner as in Fig. 1, the slight weight of which will tend to draw back the rolling lead disk to its central

position, and so prevent it shuffling out of its place, and yet have almost no effect in modifying the register of the absolute wave amplitude.

In working over an earth-shaken district of small area, such as that of Ischia, an error of observation of azimuth of even a few degrees matters little in determining the exact position of the epicentre. But on the contrary, in large areas such as the Neapolitan earthquake of 1857, and to a far greater extent in widespread disturbances such as the great Lisbon catastrophe, an error of a few minutes of a degree is sufficient to produce great divergence in the orientation of the azimuth and a consequent incorrectness in the location of the epicentre. In most seismographs so far employed, especially those of Italy, no attempt has been made to divide the circle into eight divisions, so that an error of nearly 45° could occur.

Fig. 3 represents a separate apparatus, although it would probably in practice be found preferable to replace the pendulum by the rolling disk and balls as already mentioned when describing Fig. 2, except that the contact rings *h* would then be inverted. A pendulum, *a*, with a

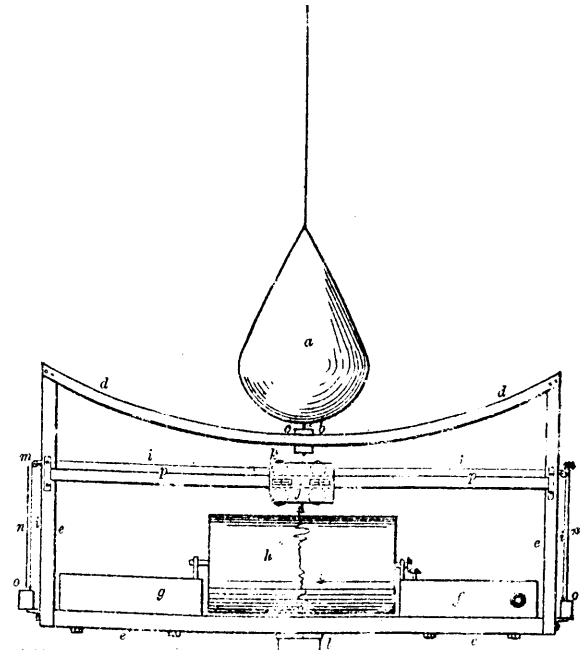

Fig. 4.—Horizontal component of wave-path register for strong and destructive earthquakes.

length of suspension suitable to circumstances of observation, carries a steel spring wire, *b*, which slides in the cylinder *c*, which, together with the light wire arm *f*, forms a universal lever moving about the fulcrum at *d*, which are gimbals. This lever should be so balanced that, if placed in a horizontal position, the part above *d* should counterpoise the part *f*. The lever carries a fine platinum wire, *g*, which, when at rest, is the centre of the two contact circles *h, h', h''*. This part of the mechanism is in connection with one pole of a battery.

The contact circles *h* seen in detail, *h, h'*, consist of a suitable number of brass segments, *l*, which have a V-shaped groove on their upper surface, and the edges, both inner and outer, are bevelled off. Each one is insulated from its fellow by the vulcanite plates *m*, which project a little on the inner, upper, and outer sides, and are sharpened to a knife edge.

The registering apparatus, consist of a number of long soft-iron spring styles bolted to the column *i*, with their

points near the revolving register cylinder *k*. A pile of electromagnets *j*, each of which is in connection with the two corresponding segments of the two contact circles and the battery when the current passes, draws one soft-iron spring style towards its poles, and brings the point in contact with the cylinder *k*. The pendulum might be made to act directly on the contact circles without the magnifying lever *c f*, if thought necessary, and the breadth of the outer circle might be greater and give a correspondingly longer dash so as to distinguish those derived from the two circles.

It will be seen that the most complex movements of the pendulum or rolling disk can be accurately registered, since four contacts will be marked in each semiphase of the oscillation of the pendulum, and a fifth point can be obtained by calculation from the instrument for registering amplitude, which, together with the position of rest, will give sufficient data to obtain the loops for each semiphase throughout the disturbance.

In large earthquakes where the wave-amplitude is very great, the rolling disk and falls would require to be of very great size, which in many cases it might be impracticable to carry into execution, although the results might be of great perfection in so doing. The present instrument (Fig. 4) is intended to replace the rolling disk where that cannot be used of sufficient size.

A strong rectangular frame, *e*, carrying two strong uprights at its two extremities, is made so as to rotate with great facility around the vertical axis *l*. It supports the registering drum *h* with the clockwork arrangement *f* and a counterpoise *g*. It practice it might be found advisable to attach those beneath the frame and so lower the centre of gravity of the whole apparatus. At a suitable distance above the drum a crossbar *p*, is attached, which should be highly polished and square in section. The weight *j* should be made very heavy, and be allowed a very easy motion by means of four pairs of wheels, *k*, which are in contact with the crossbar *p*; these might be mounted on friction wheels (not shown in diagram). Attached on both sides of the weight are the silk threads *i i*, which traverse the upright, run over the pulley *m*, and are attached to the weights *o o*, which are only heavy enough to draw the weight *j* back to its place when it has been disturbed, that is to say, only just sufficient to overcome the friction of the wheels *k*. These weights, *o o*, are traversed by the guide wire *n* to prevent them dangling about during the swinging round of the frame.

The upper part of the frame carries two parallel bars, *d*, between which is a narrow groove to allow of the sliding of the plate *c*. They form the segment of a circle whose radius is equal to the length of the entire pendulum and its suspension. The pendulum *a* has fixed rigidly to its inferior extremity the steel axle *b*, which passes through the rectangular flat block *c*, which is prevented from slipping off by a bolt-head below, so that the flat block can rotate around the axle without falling off.

The action of the apparatus is as follows:—When an earth movement takes place the whole apparatus is brought into the azimuth of the wave-path by the oscillations of the pendulum *a* in that direction, which is affected by the block *c* sliding in the groove between the bars *d*. The pendulum should, in preference, have a short suspension, so that the period of its oscillations should be less than the wave intended to be registered by the apparatus, and should possess sufficient weight to have complete command over the frame, keeping it always in the wave-path azimuth. The weight will now appear to slide backwards and forwards on the bar *p*, registering its movements by the writing stylus, attached beneath it, on the drum *h*. The moment that *j* is moved from its central position one of the weights *o* is raised from its position of rest (these weights should preferably be hollow brass boxes into which only sufficient fine shot could be poured to overcome the friction of *j*), and rises as long as *j* continues to roll along the bar; if then the second half of the semiphase is not sufficient to bring it back to its normal position this will be done by *o*. When *j* has reached its central position, *o* will have come to rest at the base of the guide wire, and so no longer has any action, but is replaced in the second semiphase by its fellow of the opposite side. Of course the influence of the counterweights in retarding the rolling mass must be experimentally tried and taken into consideration in the calculations made from the tracings.

The principle of this instrument is the acceleration and retardation of a falling body during each semiphase of an earthquake. Fig. 5, p. 384 shows a means of registering such changes

in the rate of a falling body so acted on, although some other person better acquainted with mechanical movements might possibly suggest some improvement. A rigid vertical support of considerable length, *a*, is attached to the side of a well and is connected at its upper end to the table *c*; and by a small bracket *b* two vertical guide wires *n*, pass through rings in the sides of the weight *g*, so far resembling Morin's apparatus illustrating the falling of bodies. Attached to the weight *g* is the silk thread *f*, which turns once or twice around the wheel *d*, and is supplied from the drum *k*. The wheel *d* is connected by the axle *e* and the continuous screw *h* to the apparatus *i*, which is a skeleton of flat steel springs, generally used to illustrate the distortion of a sphere by centrifugal motion. (I have proposed this in preference to the ball governors as retaining less impressed energy, which would unnecessarily complicate and even modify the results.) Sliding on the central axis of the spring sphere is a small cylinder, *j*, which is prevented from rotating by means of a ridge on its inner surface and a corresponding groove on the upright bar. This cylinder carries the writing arm and stylus, which registers on the cylinder the rising and falling of the former; *l* is the motive power of the cylinder *m*. The apparatus for detaching the falling weight *g* is not shown in the diagram, but might be of the following arrangement:—A bob suspended by a spiral spring is made to make contact with a cup of mercury, as in the old form of vertical seismometers, besides a small lever of the first order attached at one end to the bob, the other extremity being above another cup of mercury. In this way, whether the movement of the bob be either up or down, in relation to the mercury cups, contact will be either made in the first case through the lever, or in the second directly by the bob. The current thus established could be used by an electro-magnetic apparatus for removing a catch which holds the weight *g*. It could also start the cylinder *m* and stop a clock. The diagram will sufficiently explain the action of the apparatus.

If we review the advantages and disadvantages of the different instruments, I venture to say that, though far from perfection, they have much to be said in their favour. Their principal feature is the capability of registering continuously all the variations of the earth's movement during the complex disturbance known as an earthquake; that by employing large tracing drums with a spiral arrangement and time-ruled paper, accurate time records can be obtained for a considerable period and without interruption, so that a single observer could have under his command a large number of instruments, even at stations some considerable distance apart, thus resulting in much economy of trained observers. Then again the records are all permanent, being geographically inscribed. The instruments for registering azimuth and amplitude, and capable of doing so with the greatest delicacy and friction, in all cases can be reduced to a minimum or easily calculated. With regard to the registration of the vertical component of an earthquake, the old form of spiral spring and bob principle may be excluded from consideration as perfectly unreliable; and even the improvements by Messrs. Milne and Ewing, and the ingenious idea of Mr. T. Gray, with its mercury trough compensator, cannot give accurate indication of the characters of a group of earth-waves. Another instrument worthy of trial is the hydrometer vertical-motion seismograph of Mr. T. Gray (*Phil. Mag.*, September 1881, p. 209). I think, however, that this instrument might be improved by using a long thin glass tube filled with air and floating in ether or some other fluid of very low viscosity. I would, however, venture to predict that a seismometer based on the principal of a falling weight, being accelerated or retarded according as the earth moves up or down, will supersede other methods, although no doubt such means of registering as described in this paper may be greatly improved upon.

The instruments described in this paper are all of considerable size, but it seems impossible to get good results unless heavy weights and their attendant mechanisms are used so as to reduce friction to a minimum in the consideration of results; for it is certainly a pity to have imperfect results in consequence of limiting the size of the apparatus. One great objection to the falling weight seismometer is the necessity for a deep well, to give sufficient time to register an earthquake of ten or twenty or even more seconds' duration; yet, by giving the weight more work to do by the introduction of multiplying wheels, this might be reduced as the circumstances might demand.

These instruments and the remarks on them are the outcome of long meditation while wandering over the ruins of two great

earthquakes, and although expressed without a technical knowledge of mechanical construction, I hope I have made my ideas sufficiently clear.

H. J. JOHNSTON-LAVIS.

ELECTRIC LIGHTING FOR STEAMSHIPS.*

By ANDREW JAMIESON, ASSOC. M. INST. C.E., F.R.S.E.

THE Author commenced with the statement that, although it was not more than three years since the first application of incandescence electric lighting to the general illumination of steamships, the advantages accruing therefrom had been so universally recognised, that more than one hundred and fifty ships had been fitted with it, and scarcely a man-of-war or a first-class passenger-steamer now left the builder's hands without having it on board. This rapid success was mainly due to the following causes:—(1). Electric lighting on the incandescence system, when properly fitted, was more healthful, cooler, more easily handled, and more artistic than other systems of lighting; there was no smell, and no products of combustion to tarnish gullwork; it was more agreeable in every way than any of the older methods of illumination. (2). The danger from fire was less, as neither matches nor lighted tapers were required. (3). The daily cleaning and replenishing of lamps, as well as the keeping in store of highly inflammable oil, paraffin, or candles, could to a greater extent be dispersed with. (4). The expense of maintenance was not much in excess of that of the older methods of illumination (in some cases less), whilst the space occupied by the plant was not great, and its position near to, or in, the engine-room caused no annoyance to passengers.

As the dynamo which furnished the electricity for feeding the incandescence lamps had to be driven at a uniform velocity, neither the ship's main engines, nor the donkey, nor winch-engines, were suitable for the purpose. The dynamo must have an engine for itself. It was, in most cases, necessary to place this special engine and the dynamo in such a position that the men on watch at the main engines could, with a minimum of trouble, also attend to the electric plant. This position, therefore, was naturally somewhere near the starting-platform, and if possible on the ship's floors, so that undue vibration and noise might be avoided. Frequently a convenient recess could be provided, either immediately behind the main starting-platform or opposite to the thrust-block, just outside the screw-shaft-tunnel door. Only in large installations would it pay to have on board an electrician solely to attend to the dynamo, its engine, and lamps. In such cases, a convenient and cool position was generally selected between the decks, in the same compartment with, or in that next to, the refrigerating machinery, if such should be on board, so that one man might attend to both of these novel appliances.

Where practicable the axes of dynamos with large, heavy armatures should be placed fore and aft, to obviate as much as possible the effects of gyrostatic action, since the angular velocity due to rolling was greatest athwartship. The Author here gave Sir William Thomson's formula and examples, to show the pressure produced on the dynamo bearings, under different circumstances, by gyrostatic action.

In selecting a dynamo it was necessary to determine whether or not it fulfilled certain requirements:—(1). It must develop electromotive force suitable for a certain lamp when driven at a certain definite speed. (2). It must be self-regulating; that is, the electromotive force generated at the given speed must remain constant to within 5 per cent., whether working one lamp or more, or the full number of lamps. It was preferable to have a slight fall in electromotive force as the number of lamps was reduced. (3). There must be no undue emission of sparks at the commutator-brushes. (4). When running light, or with less than the full number of lamps, there must be no undue heating of any of the parts. (5). The conductivity of the copper wire with which it was wound must not be less than 98 per cent. of pure copper. (6). The insulation-resistance of the armature and electro-magnets should not be less than 10,000 ohms per volt generated at the required speed. The dynamo should be tested mechanically and electrically before being put on board ship, and afterwards, when fixed in position, by a final trial of not less than six hours' duration with its own engine, and with all the lamps in circuit. There was considerable diversity of opinion regarding the limit of speed

of a dynamo on board ship. As a consequence of the general desire for low speeds, most of the best forms of dynamos, the Siemens, the Edison, the Edison-Hopkinson, the Victoria, the Ferranti-Thomson, and the Pilsen-Schuckert, had been specially modified for ship use, so as to produce the required electromotive force and current, at speeds varying from four hundred to six hundred and fifty revolutions per minute.

The success or failure of an installation on board ship depended as much upon the engine as upon the dynamo, and every care should be taken to procure one that needed the minimum of attention, and was not likely to break down. The engine should be capable of driving the dynamo during a voyage to Australia and back, without a hitch and without requiring overhauling. The demand for such engines, more especially for those driving direct, had led to the production of a great variety, many of them excellent in workmanship and in detail. It was frequently necessary that the engine should be capable of doing its work when supplied with steam either from the main, or from the donkey-boilers, so that the electric light might be available in port as well as at sea. This entailed capability for working under variable pressures, and thus the size of the engine must be adopted for the lower pressure. One of the most important adjuncts to the engine was its governor. It should be sufficiently sensitive and reliable in action to keep the engine within 5 per cent. of its normal speed, with a load varying 90 per cent., and a boiler-pressure varying 10 lbs. per square inch. No mechanical governor could do this, and consequently a good electrical governor, which would automatically open and close the throttle-valve, in perfect synchronism with the load, or work to be done, and leave the valve in its last position until a change was made either in the load or in the steam-pressure, was greatly to be desired. The Author showed how this problem had been solved by means of his electrical governor.

Then were detailed the different methods of driving dynamos on board ship by belts, ropes, gearing, direct-driving fast-speed engines, such as Brotherhood's, the Westinghouse, Messrs. Siemens' Frictional Drive, etc. The Author explained the methods of fitting leading wires into vessels, instancing certain well-known cases by plans of the S.S. "Adelaide" and the S.S. "Arawa;" and gave a practical rule which he had been in the habit of using for the dimensions of such wires. Insulation-resistance was too often neglected by electric-light engineers. Amongst submarine-telegraph engineers it was considered of vital importance to watch the insulation-resistance with the most rigid accuracy, not only during the manufacture of a cable, but during its submersion and after it had been laid; whereas, in the case of electric lighting, those charged with the fitting up of an installation very seldom thought of, or even knew how to take, insulation-tests, either of the dynamo or of the leading wires. It was far from right to allow leads to be run up like bell-wires, without the slightest knowledge as to whether a flaw or a fault had crept in, and all engineers should insist upon rigid inspection, as well as thorough and searching tests, before an installation was passed. The insulation-resistance-standard need not be nearly so high as in the case of submarine cables; but nevertheless it did require to be several hundred times more than the copper-resistance, otherwise a fault would soon develop, and short-circuiting occur, under the combined influences of the electromotive force, and damp or wet. The dielectric should, therefore, in addition to being a good insulator, be thoroughly water-tight, and as little liable as possible to be affected by atmospheric changes. The Author then gave a description of what he found to be the best form of switches, fusible plugs, lamp-holders, lanterns, and globes. Finally he directed attention to the powerful search-lights used on board men-of-war, and to the novel application of arc-lighting for salvage and fishing purposes.

The Paper was illustrated by a large number of diagrams.

Who thought that America could boast of a church nearly 370 years old? It is said that the oldest church in America is situated in the village of Tadousac, where the Canadian river Saguenay flows into the St. Lawrence. The church was built by the French discoverer, Jacques Cartier, for the French colony he had founded. It is only a small building, being about 20 ft. square, with a very low ceiling, and was erected in 1517, 25 years after the discovery of the continent. It contains a very remarkable picture of the Virgin Mary, painted more than 300 years ago by one of the Jesuit fathers at the mission.

* A Paper read before the Institution of Civil Engineers, Eng.

THE SANITARY CONDITION OF THE PANAMA CANAL WORKS

A report on the sanitary measures adopted for preserving the health of workmen engaged on the Panama Canal works has been made to M. de Lesseps by M. Regnier. According to this report the climate is warm and humid, but does not exercise on Europeans that depressing influence which is observed in some other tropical countries. The temperature varies from +24 deg. to 30 deg. Cent. in winter, and rises to +35 deg. Cent. in summer. Winter is the rainy season. Two great hospitals have been erected, one at Panama, the other at Coloh, into which sick workmen are received; and along the entire length of the canal, doctors are stationed to visit workmen in their homes, and if necessary order them into the hospitals. Sisters of Mercy are the nurses of the latter. A service of inspection has been organised since 1881 to examine the men sent to the works, for it was found best only to send men in sound health and in the prime of life. The administration have also established a sanatorium at Tobago for convalescents; and some of those recovering from grave maladies are sent home. Workmen who have laboured for eighteen months or two years, and desire a visit home to recruit, are also permitted to do so, and most of these return afterwards to their duties at the works. Thanks to these excellent precautions the mortality amongst workmen in the isthmus is even below that in great cities and large manufacturing factories.

THE ENTOMOLOGY OF A POND.—(Knowledge.)

BY E. A. BUTLER.

(Continued from page 351.)

ABOVE THE SURFACE.

THOSE insects that make their home in the pond in their early life only, when fully grown still haunt the neighbourhood, never straying far from the scene of their juvenile associations. Their movements will, of course, be very largely determined by the functions they have to perform. Those whose only business it is to found new families, and which so thoroughly devote themselves to this work as to have but little thought about their own sustenance, will evidently have no temptation to leave the arena of their family labours, but will hover about close to the pond till they have fulfilled their task, and then, after but a brief stage of enjoyment in the performance of parental duties, either die of old age, or more probably fall victims to the voracious appetites of predatory insects, or of insectivorous birds or fish. Such as these will either be found executing merry dances just above the surface, lurking amongst the rank vegetation that fringes the banks, or resting on overhanging trees, from which positions they may easily be dislodged by disturbing their place of retreat. But those that are destined for a longer existence, and so have to make vigorous onslaught upon nature on their own account, as well as to give birth to new generations, will often take foraging excursions into neighbouring woods and fields, though the procreative instinct will with them, too, suggest a speedy return to the water which is to be the nursery of their expected brood.

Coming under the former category are first the *Ephemérides*, or May-flies, whose larvæ formed the subject of part of our last paper. There is no mistaking a May-fly (Fig. 1). A most fragile creature, with four membranous and reticulated wings, of which the hinder pair are very much smaller than the others, and sometimes, indeed, absent altogether, with two or three long filaments at the

tail generally much longer than the insect itself, and with the organs of the mouth in the most rudimentary condition possible—such is the insect that, in consequence of the sudden appearance and the as sudden disappearance of its myriad swarms, and the extraordinary brevity of its adult life, has attracted popular attention from the times of Greeks and Romans, to the present day, and has, more often than almost any other insect, been used to point a moral to human kind. The name *Epheméride*, a Greek word meaning living for a day, indicates what is usually considered to be the extreme duration of their perfect existence. In captivity they have, it is true, been kept alive for upwards of a week; indeed Stephens reports having kept one for more than three weeks; but there is no doubt that, in a natural condition, this longevity would not have been attained, and in the majority of cases the perfect existence seems to last little more than a few hours. They have no power whatever of taking food, and are utterly defenceless, so that they have no chance of holding their own against the numerous foes that with hungry eyes are looking longingly upon them. Their sole business is to become mated and lay their eggs, and this exhausts all their energies. The antennæ are extremely short, but, as if to counterbalance this, the forelegs are sometimes extraordinarily long. The wings have a number of nervures running longitudinally at short intervals, and the spaces between

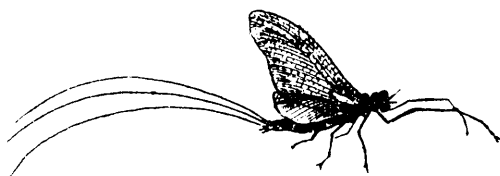

Fig. 1.

them are divided into tiny quadrilateral figures by numbers of short transverse nervures, so that the whole surface of the wing is composed of minute enclosed areas which are largest in the centre and smallest at the outer edge. Several species of these insects are known to inhabit the British Isles, but their preservation is a matter of considerable difficulty. Their texture is so fragile that such parts of the body as are of most importance in the separation of the species shrivel up to mere shapeless masses after death, if they are simply allowed to dry as is usually done with insects. A collection of them, therefore, is of but little value to a systematist unless they are preserved in spirit into which they have been plunged when fresh and soft.

They are remarkably regular in their times of appearance, and immense swarms arrive at maturity at almost the same instant, and few phenomena have excited more admiration and wonder than the sudden appearance of myriads of these insects where a few moments before not one was to be seen, and where their presence would be hardly likely to be expected; for, owing to their mud-loving propensities, they are seldom noticed during their long larva- and pupa-hood, and thousands may be close at hand without anyone except those who specially search for them being any the wiser. To the naturalists of a century and a half ago, coming fresh to the observation of nature at first hand, when, as yet there was but the most scanty literature on the subject, the sudden appearance of these gigantic swarms was matter of such intense interest, excitement, and delight, as in these more matter-of-fact days of ours, with the charm of novelty destroyed by an abundant literature, can scarcely be credited,

and it is delightfully refreshing to place oneself for a time in communication with these great spirits of old and try to see things with the eyes with which they saw them. The renowned French naturalist, Réaumur, gives a most minute and graphic account of the first swarm of May-flies he witnessed, and the details are so remarkable that they are worthy of recapitulation, if for the thousandth time. It was in the year 1738 that the experience occurred to him. His garden was situated on the banks of the Marne, and on August 19 a fisherman informed him that on the previous day the flies had begun to appear along the river; or, as he expressed it, the "manna had begun to fall"—a metaphor commonly used to express the advent of the swarms. The illustrious naturalist, therefore, being determined to have a near view of the hatching of the creatures, got into a boat about three hours before sunset, and, proceeding down the river, detached from the banks great masses of earth which contained abundance of pupæ, transferring them to a tub of water he had taken with him. Having stayed out till about eight o'clock, intently watching both banks and tub, but without seeing very many flies, he bethought him that, as a storm seemed to be brewing, terra firma would be preferable to an open boat. He therefore landed, and had the tub conveyed into his garden. But just at this moment the insects began to emerge from the tub in vast numbers, crowding up to shed their skins on to every exposed piece of earth, in order must have been a most entertaining one; but, in the midst of it all, the rain came on so severely that the observer, ardent as he was, was obliged to beat a retreat, not, however, before covering up the tub with a cloth, that he might not lose his precious insects. The storm soon abated, and he again visited the tub, when he found the crowd of insects much increased, many of them having been drowned through their inability to find sufficient standing room under the cloth. By this time it was quite dark, so that the observations had to be conducted by torchlight; but the light proved a strong attraction to the multitudes of flies that were now emerging from the river, and they flocked round in such numbers that they soon completely covered the cloth which had again been thrown over the tub, and might even have been taken up in handfuls. The delighted naturalist and his attendants now made their way to the river, and here the spectacle was far more astonishing, for, as he says, "the myriads of ephemera which filled the air over the current of the river and over the bank on which I stood are neither to be expressed nor conceived. When the snow falls with the largest flakes, and with least interval between them, the air is not so full of them as that which surrounded me was full of ephemera. Scarcely had I remained in one place a few minutes, when the step on which I stood was quite concealed with a layer of them from two to four inches in depth. Many times I was obliged to abandon my station, not being able to bear the shower of ephemera, which, falling with an obliquity less constant than that of an ordinary shower, struck continually, and in a manner extremely uncomfortable, every part of my face. Eyes, mouth, and nostrils were filled with them." Multitudes, of course, were drowned, but as fast as the stream carried them away, new ones were ready to take their place. The swarms continually increased in density till between 9 and 9.30, when they reached their maximum; but in the succeeding half-hour their numbers rapidly diminished, and by ten o'clock the marvellous spectacle had completely vanished; the vast hosts that had filled the air so short a time before, having fulfilled their destiny, were now numbered with the dead. Other batches came forth some nights afterwards, but not again in such enormous numbers. The fishermen reckon three successive days for the greatest "fall of the manna," and during this time, of course, the fish hold a grand

carnival, gorging themselves on the delicate morsels as they fall into the river.

It is remarkable that in Ceylon there is a species of May-fly the abdomen of which is luminous—sufficiently so, indeed, to enable one to capture the insect, even on a very dark night.

The caddis-flies, which we left a short time ago, just emerging from pupahood, may now engage our attention. Of these insects we have upwards of 150 species already recorded from the British Isles, but, no doubt, others exist which have not yet fallen into the hands of the very small band of entomologists specially interested in the group. The larger kinds, which in some cases reach an expanse of wing of almost two inches, are nocturnal in habits, concealing themselves by day amongst herbage and on the trunks of trees. But many of the smaller ones may be seen during the daytime flitting backwards and forwards with an uncertain kind of movement just above the surface, seeming sometimes to be trying how near they can approach the water, without actually touching it. All these insects are delicate in texture, their four membranous wings being easily damaged, and their soft bodies, like those of the May-flies, shrivelling up in an unsightly manner after death,

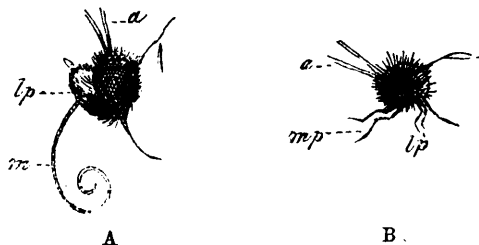

a peculiarity which does not tend to lessen the difficulties that, at the best of times, beset the discrimination of the species. The wings, which are always some shade of brown or black, are sometimes, like those of moths, adorned with patterns, and as, in many respects, they closely resemble the latter insects, for which, indeed, they are often mistaken, it will be best first of all to point out the differences between the two orders, *Lepidoptera* (moths) and *Trichoptera* (caddis-flies).

On placing examples of each side by side, with wings expanded, a superficial glance will detect little more difference than that the wings of the caddis-fly, especially the hind pair, have a semi-transparent and somewhat glossy and iridescent appearance which is absent from those of the moth, and the most important structural differences will need microscopic work for their complete determination. Applying the microscope first to the wings, we find that in the moth the pattern is due not to the colour of the wings themselves, but to innumerable minute appendages in the form of tiny scales attached to the wing by the pointed end only, lapping over one another like slates on the roof of a house, and producing by their different colours a sort of mosaic pattern, the elements of which are so small that the mosaic effect is lost when viewed simply by the naked eye. On removing the scales, which can be done by gently brushing with a camel's hair brush, we find that the true wing consists of a transparent, colourless membrane with nervures forming its framework. Examining the caddis-fly in the same way, we see that the nervures are more numerous, and that such pattern as there may be, which is generally not a great deal, is produced partly by the coloration of the membranous wing itself, and partly by minute hairs, not scales, scattered more or less thickly over the surface. These differences will generally suffice for the separation of moths from

caddis-flies; but there are a few moths that, so far as appearance and clothing of wings are concerned, approach very near to the Trichopterous type, the wings being semi-transparent, glossy, and iridescent, and the scales attenuated to such a degree as to be scarcely distinguishable from hairs, a condition best exemplified in the common pale brownish moth, *Nudaria mundana*. The antennæ of a caddis-fly are generally proportionally longer and stouter than those of a moth and are carried, pointing straight forward in front of the head. In the organs of the mouth (p. 377) there is a great difference. The mouth carries a pair of long, flexible appendages closely applied to one another, and curled up in a flat coil which is placed in a vertical plane underneath the head; no such coiled apparatus exists in any other kinds of insects. On each side of this coil is a jointed organ, clothed more or less thickly with scales, the pair of which form between them a sort of groove, into which the coil fits. These two pairs of organs are called respectively maxillæ and labial palpi, and are the principal organs of the mouth in the Lepidoptera. The maxillæ, which can be uncoiled at pleasure, carry along their inner edge, which is grooved, numerous short hooks, those of one side interlocking with those of the other, and thus forming a central tube, up which the liquid food taken by the insect must pass in order to enter the mouth, an aperture between the bases of the maxillæ. In the caddis-fly the only organs distinctly perceptible are two pairs of delicate, jointed appendages, the maxillary and labial palpi. Though its larva possessed a pair of stout jaws, and was able to make good use of them, the perfect insect is, equally with the moth, entirely destitute of any such organs; the moth's coiled maxillæ, however, sufficiently distinguish the insect. In a few moths the maxillæ are quite rudimentary, the palpi being almost the only recognisable mouth organs; this manifestly approximates the mouth in appearance to the Trichopterous type, and there is a noteworthy instance in which even competent entomologists were for a time misled by this condition. The insect in question is a small, whitish moth, called *Acentropus niveus*, which, as it is a genuine lover of ponds, will come in for more lengthened notice later on; it was bandied about from one order to the other, at one time being considered a caddis-fly, at another a moth, till the discussion having waxed hot and strong, it found a final resting-place amongst the Lepidoptera.

Some of the caddis-flies, viz., those of the family *Leptoceridæ*, are remarkable for the enormous length of their antennæ, which are sometimes four or five times as long as the body. It is these little creatures, some of them sooty black in colour, that form dancing groups just above the surface of the water. By entomological beginners they are sure to be mistaken for moths, especially as there is a well-known family of moths of the same size, of similar shape, with equally disproportionate antennæ, and with their colours, too, sometimes not unlike those of the *Leptoceridæ*. Attention to the structural characteristics mentioned above will, however, infallibly lead the observer to their true systematic position. It should constantly be borne in mind that mere superficial resemblances count for nothing to the systematist; insects that look something alike in general appearance are not necessarily at all related, for there are numerous instances of mimicry between species belonging to altogether different orders; an examination, therefore, which pays more attention to general effect than to matters of detail, will often fail to detect either real points of similarity or of disagreement; and students of entomology should be very careful in forming an opinion as to an insect's systematic position without the closest scrutiny of all essential parts, assisted by at least a hand-lens, and, if necessary, even by the compound microscope.

Caddis-flies are to be found during the summer months. They fly with a heavy, zigzag sort of flight, and when in the net often simulate death, bringing the wings close alongside the body (the hind pair, which are much larger than the fore, being folded up like a fan), relaxing their hold, and falling over on their side. But any attempt to secure their persons will speedily convince them of the futility of this pretence, and elicit spasmodic struggles for liberty.

There are some other water-frequenting, winged creatures, such as the stone-flies, willow-fly, and alder-fly, that, like the caddises, are used as bait by anglers, and are therefore sometimes confounded with them. These, however, though in habits resembling the subjects of the present paper, are pretty easily seen, by examination of the wings, not to belong to quite the same group; their wings are more or less closely reticulated by means of a number of *transverse* nervures in addition to the

longitudinal ones (those of caddis flies being chiefly longitudinal), and are only *very* slightly hairy, generally, indeed, imperceptibly so, without considerable magnification; and, in consequence, are more transparent than those of caddis-flies. Most of them, too, carry two long filaments at the tail, which the true caddis-flies never do. These insects, together with a number of others, such as May-flies, dragon-flies, snake flies, and lacewing-flies, constitute the wonderfully mixed assemblage known as the order Neuroptera—a group with which some people associate the caddis flies. The stone-flies and willow-fly, together with the angler's "Yellow Sally," constitute the family *Perlidæ*, a group of that section of the order called Pseudo-neuroptera. The alder-fly belongs to the *Sialivæ*, a family of another section called Planipennia, which contains also the beautiful lacewing-flies, or "golden-eyes." But a more detailed notice of these must be reserved for our next paper.

(To be continued.)

IVY.

BY GRANT ALLEN.

Though every one of us has been perfectly familiar with common ivy from his boyhood, upward, I wonder how many people have ever noticed its pretty bunches of thickly-clustered, pale yellowish-green flowers that form such large and prominent masses in the early autumn. They are just now in full blossom, and are attracting, as usual, the flies and bees in great numbers to their abundant stores of easily accessible honey. Let us stop for a while beside some knotted stem that clammers close against some low wall, and examine this old, familiar favourite in the light cast upon it by the discoveries of modern biological science.

Ivy is a native English evergreen creeper, one of the very few large-leaved evergreens really indigenous to our islands; for though the laurels, and acubas, and laurustinuses, and rhododendrons of our shrubberies have made us now perfectly at home among the class by naturalisation, yet almost all our true British evergreens are more or less needle-leaved conifers, such as the Scotch fir, the yew-tree, and the junipers. Holly, an undoubted native of England, and box, which is very probably an introduced alien, are its chief competitors in this respect. In its truly wild state, the lower branches of ivy creep along the soil, while the main stems climb up trees, walls, or rocks, to which they adhere by means of small fibrous root-like excrescences. This is one out of the many ways adopted by comparatively feeble plants to raise themselves, half parasitically (so far as support alone is concerned, I mean) up the stout trunks of other and more sturdy woodland competitors. Compare it, in this respect, with the straggling arched-branches of the common blackberry bramble, loosely festooned by means of their curved and hooked prickles over the blackthorns and May-bushes in the wastes and hedges; or with the little sucker-like supports of the virginia creeper, clinging fast to the tiny crannies and asperities of a brick wall here in England, as it clings in its native woodlands to the chinks and rugosities in the bark of trees; or with the twining tendrils of the pea, really abortive leaflets, that twist twice or thrice or even oftener round the twigs and branchlets of the supporting bushes; or with the curling leaf-stalks of the canary creeper, where the petiole of a true and active leaf performs the same clasping function. In every case, the end to be attained is the same—the plant endeavours to raise itself by means of some tree, shrub, or bush, above the competing mass of foliage on the ground below, and to reach the open air and free sunlight overhead; but by what an immense variety of means it attains in various cases this desired result! Any trick of habit, be it hooked hair (as in goosegrass), or twining stems (as in convolvulus), or mouth-like suckers (as in dodder), or twisted leaf-stalk (as in clematis), that happens to aid in this object, is immediately seized upon by natural selection, and developed and encouraged into an organic peculiarity of the whole species. In our little English flora alone, to go no further, it is an interesting study to look at all the cases above enumerated side by side with those of bryony, tamus, wild madder, dog-rose, cinquefoil, vetches, hop, and periwinkle, whose diverse modes of obtaining this single end should be noticed in detail by the country walker.

The leaves of ivy form by far the most conspicuous part of the plant to most ordinary outside observers. Their shape is very characteristic, so much so that the epithet "ivy-leaved"

has been given to many other plants, such as the ivy-leaved ranunculus, the ivy-leaved veronica, and the ivy-leaved toad-flax. It is a noteworthy fact, too, that all the plants possessing foliage of this peculiar broadly-lobed form are trailers or climbers; and in most of them the leaves habitually form a single layer—lie one deep only—over the wall, or tree-trunk, or soil on which the plant is creeping. In short, this form of leaf seems specially adapted for climbing plants; its angles dovetail neatly into one another, and the tip of each fills the hollow at the stalk of its neighbour, so that every leaf obtains the full benefit of the sunlight on all its parts, without interfering with the equal illumination of its like-minded fellows. I do not say that this is the only, or even the best, way for obtaining that result; but it is one way, and a sufficient way; and that is all that natural selection can, as a rule, succeed in securing. One has only to look at a mass of wild ivy creeping up a wall or tree in order to see how admirably the whole body drapes the entire space it covers, leaving very few interstices, yet seldom casting a shadow over any part of its own surface. I say "wild ivy," because many of the cultivated exotic varieties in our gardens being grown for the sake of their luxuriant foliage alone, under artificial conditions, in richly-manured soil, produces copious masses of overlapping leaves very different from the native parsimony of the indigenous field species.

Observe, however, that the leaves upon the upper flowering branches are extremely unlike in form to those which cover the naked wall with their bright verdure. These upper shoots rise freely into the air, and have rounded or oval leaves, not at all "ivy-shaped," disposed pretty equally on every side, so as to catch the open sunlight into they have raised themselves. The upper leaves often somewhat resemble lime-leaves or laurustinus-leaves in general outline; and they clearly show how much the shape of the foliage depends upon the surrounding conditions of air and sunshine. Where these conditions of growth are supplied one-sidedly, as on the wall, the foliage is all turned outward, and so shaped as to economise every portion; where they are equally diffused all round, the foliage grow out alike on every side, and avoids mutual interference by its spiral arrangement along the central axis. Very starved ivy, on a dry wall, has usually very reduced and deeply-divided leaves, with finger-like lobes; very luxuriant ivy, when it overtops its support, has usually very full and rounded leaves, often with no perceptible lobes, and sometimes almost circular in shape.

Why is ivy evergreen? I believe for this reason. It is not a plant of very cold countries; it won't grow in North Germany, Russia, or Siberia, and Britain is almost its northern limit. Southern Europe, North Africa, and Western Asia are its favourite dwelling-places. In the wild state, it is chiefly a woodland plant, clambering up the trunks of trees in the great forests. Hence it is shaded during a greater part of the year by the leaves on the deciduous trees, and it has to lay by the material for its growth and flowering and fruiting in autumn, winter, and spring, when the bows above have lost their foliage. As a matter of fact, even in England, its growth is most luxuriant in late autumn, it flowers in October and November, it goes on putting forth fresh leaves and wood as long as the season permits it, it ripens its berries through the winter, and it begins leafing again as soon as the spring is once more with us. In more southern countries it works uninterrupted from October to May, and lies by almost dormant during the long dry summer. It is thus essentially a winter plant, and that, I take it, is why its leaves are evergreen.

The curious and pretty yellowish green flowers are worth a moment's consideration. They have each five small petals, and five stamens, with a broad disk in the middle, surrounding the central stigma. This disk secretes quantities of honey, which stands in little drops upon its surface, and can be readily distinguished with the naked eye and tested with the tongue. The honey attracts large numbers of flies, bees, and wasps, but especially the hive-bee, which in England, at least, is certainly observers give this rôle in Italy and France to the flies and beetles. The stamens mature first, so as to prevent fertilisation from the same flower; and in this state the petals are simply expanded, and the honey abundant. Bees visiting such flowers carry away pollen on their heads for the next they visit. Afterwards the blossoms reach their second state, the petals roll backward, the stigma ripens, and the honey decreases greatly in quantity. Bees visiting these maturer flowers rub off upon them the pollen they have brought from the ripe

stament of neighbours in their first state. Inconspicuous as the blossoms are, individually, their habit of massing in large clusters, and their smell of honey, seem to stand them in good stead of brilliant petals; for they are much resorted to by all the insects that still fly about in late autumn.

After fertilisation, the berries begin to grow as best they may through the winter; but they do not ripen or assume their bluish-black tint till the next year. They are then much eaten, and their seeds dispersed, by birds, which find these dusky hues very attractive, as in the sloe, the blackberry, the whortleberry, and the privet. A southern variety in our gardens, however, has prettier berries of a bright yellow colour.—*Knowledge*.

CHINESE FURNITURE, COSTUME AND LOCOMOTION.

The Chinese Court at the Health Exhibition is one of the most complete of the International series, and the decoration of the galleries in which the exhibits are arranged is carried out, as we have previously noted, in a characteristic manner chiefly by native workmen. By order of the Inspector-General of Customs, an official catalogue* descriptive of the collection has just been published illustrative of several details of Chinese life in respect of education, music, dress, furniture, locomotion, cookery, and shopkeeping. To-day we are enabled to give some drawings, chosen from the official sketches, which show some few of these features and furnish interesting particulars of Oriental ideas of comfort and luxury. With regard to dress in general, the habits vary in a corresponding degree, not only with caste and class, but chiefly with the very extreme variations of temperature which the vast empire of China experiences within its far-reaching limits, from tropic heat to semi-Arctic cold. During summer, however, in most parts of the country the heat is very great, and the houses are very close and enjoy but little free circulation of air. The drainage is bad, and the floors of dwellings and roadways in streets are both cold and damp. Artificial heating owing to dearth of wood and the dearth of coal, is but sparingly resorted to except in the extreme north, where heated beds (k'ang) and open stoves, consuming balls of coal dust mixed with clay, are in use. These circumstances from the earliest times have caused the adoption of clothing best suited to secure coolness in summer and warmth in winter. Shoes with thick soles of closely-pressed paper, made from the bamboo, of old cotton, felt, or cloth, and practically impermeable to either damp or cold, are adopted. Long flowing robes keeping the lower extremities warm in winter are in use, and these allow during summer weather the employment of loose underclothing without marring the general symmetry of the dress. The quantity and thickness of the clothing vary with the temperature, and those who can afford it adopt no less than five distinct and well-defined classes of clothes, their wardrobe extending from the thin unlined silk gauze of summer days to the wood-wadded fur skins of winter use. In Europe or in America too early a change in the thickness of the underclothing may very readily result in colds or other sickness, but with the Chinese mode of dress such alterations can be made with the greatest ease and without risk. In summer, when the European is suffering from the sweltering heat of his national garb, the Chinese, in pale green or pure white silk, scarcely feels the heat; and in winter, when the European would be intensely cold, the Chinese, with his white fox and other furlined raiment, wraps it in folds about him and enjoys comfort and warmth unknown to the people of Northern Europe, who dress in more closely-fitting costumes. His boots are ugly and hinder speedy locomotion; but it is to be remembered that a rapid movement of any kind in China is considered unbecoming, while all who can possible afford to do so will ride in a cart or chair in preference to going on foot. Fashion holds a sway in China little if at all less despotic than it does in the West; and though the observant foreigner may fail to detect the minutiae of change, a glance is sufficient to enable a native to notice whether the dress of a person he meets conforms to the fashion of the day, and, if not, to fix its age, and the same remark applies equally to man's dress as to woman's. The mincing gait of the woman is their most striking characteristic, which results from the almost universal practice of cramping their feet when quite young. This barbaric custom dates from the

* Illustrated Catalogue of the Chinese Collection of Exhibits for the International Exhibition. London: Wm. Clowes and Sons, Limited, 13, Charing-cross, S.W.

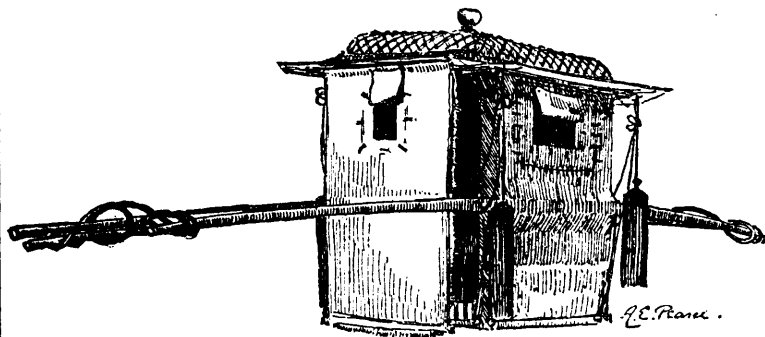

FIG. 1.—THE SEDAN CHAIR.

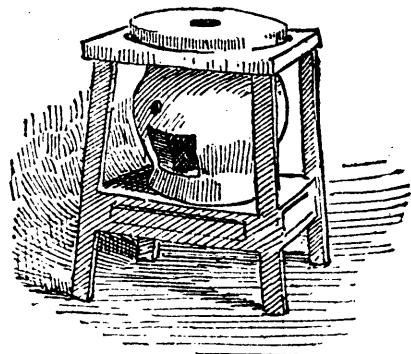

FIG. 5.—LIME STOVE.

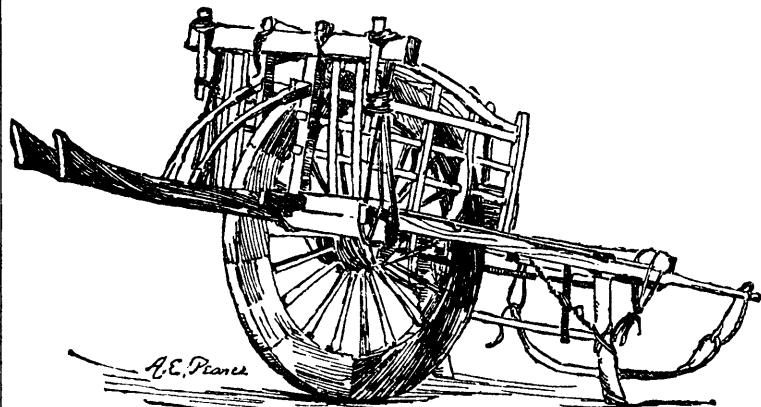

FIG. 4.—THE WHEELBARROW.

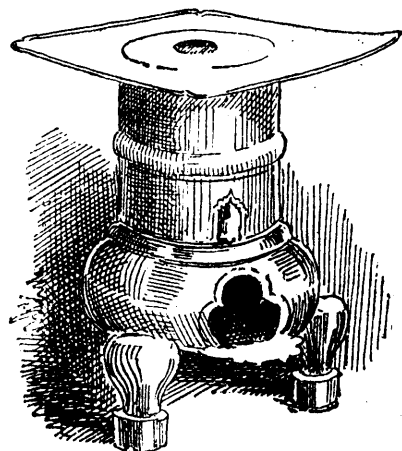

FIG. 6.—METAL STOVE.

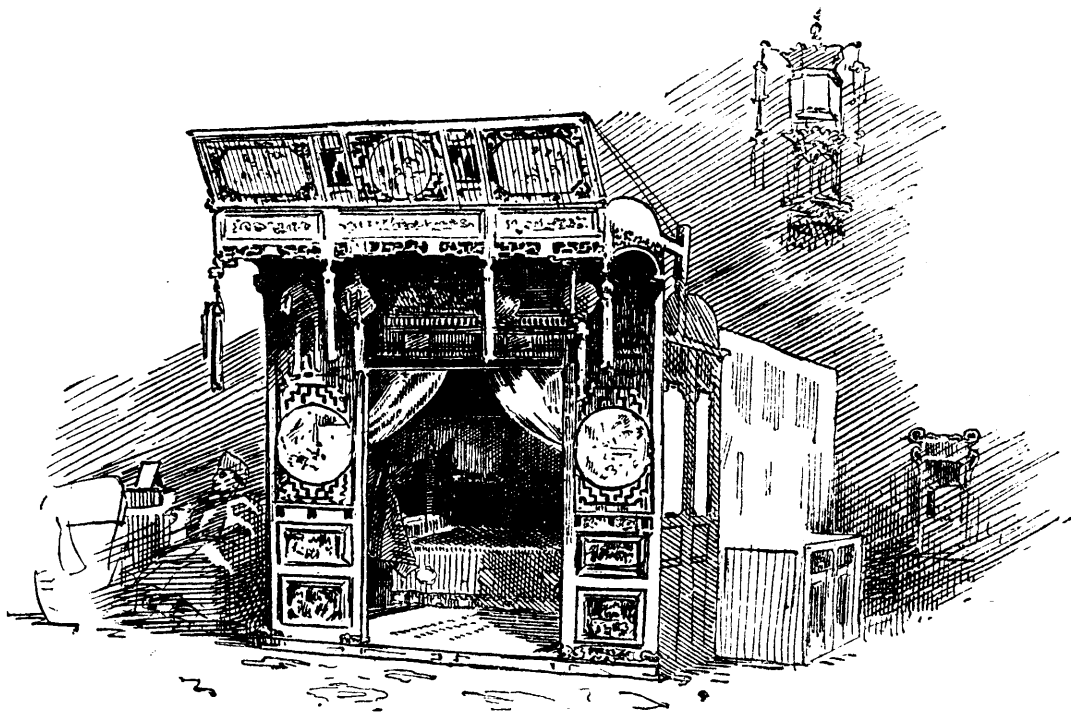

FIG. 7.—WINTER BED IN MIDLAND AND SOUTH CHINA.

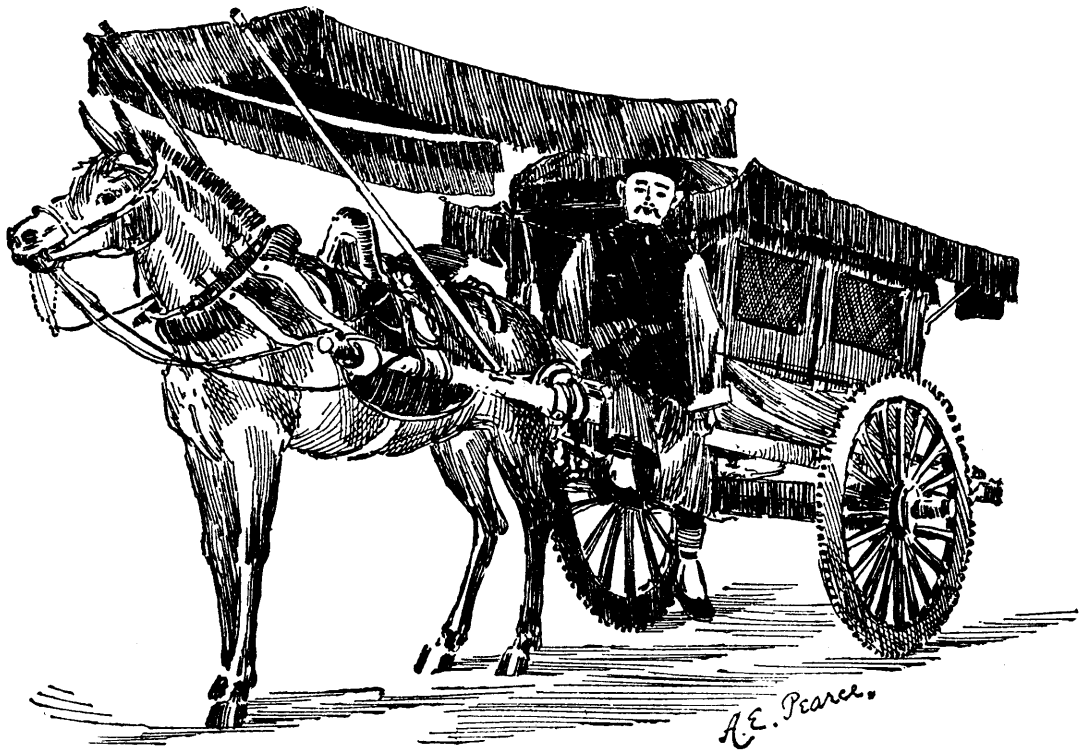

FIG. 2.—THE PEKIN CART.

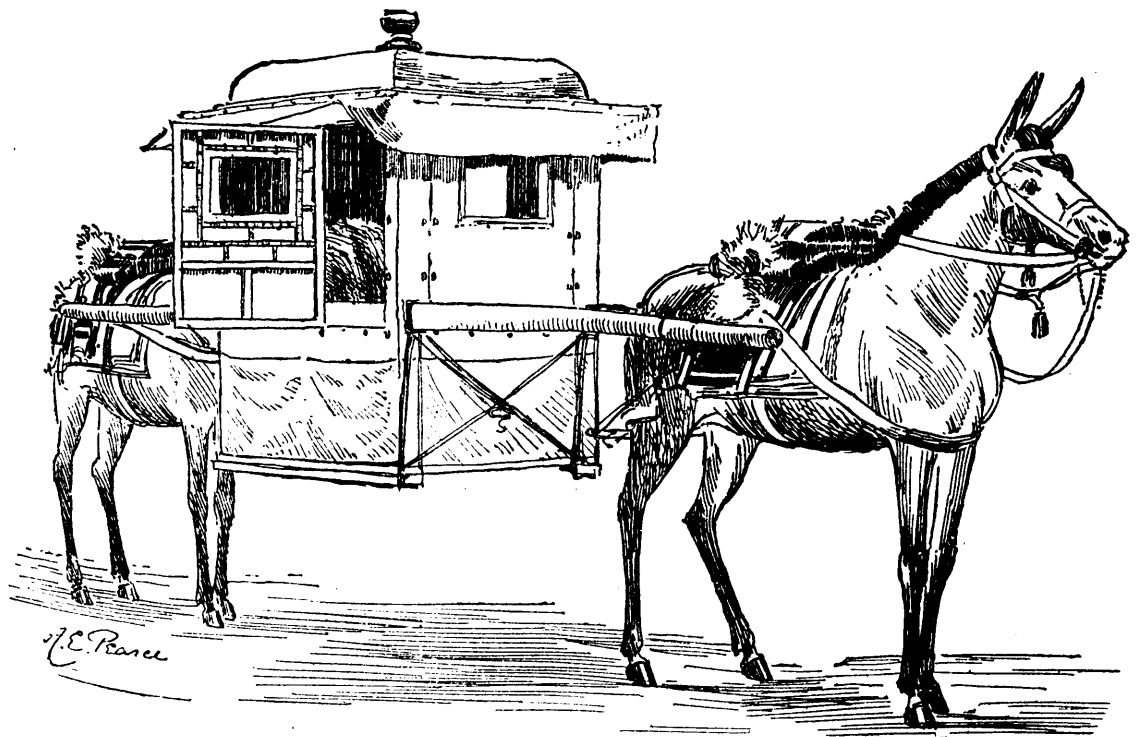

FIG. 3.—THE MONGOLIA MULE LITTER.

days of Yao Niang, the lovely concubine of Li Yu, with whose downfall in A.D. 975 came to an end the short-lived dynasty of the Kiangnan of Southern T'ang. Of this far-famed maiden it is recorded that her feet were gracefully cramped in the resemblance of the new moon. In Peking alone the Chinese ladies allow their feet to retain their natural proportions. In official costumes their are endless varieties, and the distinctive insignia of the nine recognised grades (each of which is divided into two classes, upper and lower) of official rank is rigidly defined by law. Court costume is even more elaborately confined and provided for, with dragons in plain colours, and dragons in gold or dragons in silver, and these either erect, in motion, or sitting at ease, according to the royal blood, rank, or degree of the wearer, his occasion, business or importance. These dresses find a climax in the "Mang p'ao," a robe which is literally embroidered all over with dragons, a vestment of festivity and rejoicing. Of the marriage customs and catafalque funeral ceremonies we have not space here to give particulars, though the details of cremation and the ovens used on these ceremonial occasions are singularly interesting and barbaric. The "Poo-Jung Tap," or ossuary, which may equally well be described as the Charnel-house or mausoleum, contains the ashes cast from the cinerary urns and deposited in red bags, and, according to Buddhist ritual the charred remains of not less than 5,048 monks can be thrown into these receptacles. The ossuary is then hermetically sealed, never to be again opened by the hand of mortal man. The Sedan chair (Fig. 1) which we give furnishes an idea of the palanquins in common use by all officials when paying visits of public business; the chair being carried by four bearers, preceded and followed by a large number of attendants wearing tablets showing the officer's rank and titles, and carrying flags, umbrellas, etc., and if the occupant of the chair be of high rank, he is accompanied by a body-guard of soldiers. In the southern parts of the empire these chairs form the usual means of locomotion for short journeys, and water communication is used for long ones. The cart is only met with in the north of China, and the Peking cart here drawn (Fig. 2) is of the largest size for the use of officials. The shafts are of pear-wood, the axle is of wood from Manchuria, and the wheels of wood from Shansi. These carts are exceedingly strong, as indeed they need be, owing to the severe jolts occasioned by the inequalities of the roads, especially on the paved high-roads, which frequently have ruts worn in them a foot in depth. Mules are used in these conveyances, and, being difficult of control, have the bit placed over the upper gum, and not in the mouth. The sides of the body or hood of the cart are furnished with windows, glazed in winter and open in summer, and the covering cloth of the framework varies in colour according to the rank of the owner. The mule litter next shown (Fig. 3) resembles a heavy chair built on strong poles, and is used for long journeys, carried by two mules, one behind and one in front of the litter. This style of travelling is not very rapid; but in Mongolia the "ambar," or governors, sometimes keep the mules going at full gallop, and thus can cover a very long distance in a day. Fig. 4 illustrates an ingenious contrivance, of immense utility in the north of China, for the carriage of bulky loads over narrow tracks. While the cart is better adapted for the transport of persons, this simple-looking wheelbarrow is preferred for the carrying of packages, because it is able to bear a larger cargo at a cheaper rate, and with less danger of the breakage of the machine. In the plains, when the wind is favourable, a sail is hoisted above the mountain of articles packed on the barrow, and the fatigue of the puller is thus greatly alleviated. The weight of the barrow itself is comparatively nothing; but the difficulty of balancing the vehicle is alone a task only to be accomplished after much practice. We have already referred to the limited use of stoves, and we now give two specimens. Fig. 5 is a lime stove, and Fig. 6 shows one of metal. Charcoal heated to a white heat is used, and the stove is kept three-parts filled with charcoal ashes, upon which new charcoal is placed. A fowl or pheasant having been served in slices, the guests cook the portion they have taken then and there.

The furniture shown at the Exhibition is made of hard wood stained black and inlaid with mother-of-pearl and enamel, the tables and seats covered with marble. Canton wooden furniture is usually very light, and it is also made of rattan or bamboo in very comfortable shapes and patterns. The Ningpo furniture of Midland China is larger in general form, and the more important pieces frequently constitute in themselves a kind of room with compartments, while their beds are re-

nowned as the make of Sung Sing Kung, and which vary in value from £600 to £800 each. Fig. 7 illustrates a winter bed used in Midland and South China, furnished with overhanging tester in front and a sort of dressing lobby or porch within, gaily elaborated and fitted with toilet articles, mirrors and combs. Chinese shops and music, musical instruments, literature, books, and implements complete the collection, and render it one of the most valuable hitherto brought together in London, and the copious handbook which we have thus noticed renders the Exhibition specially interesting and easy of reference.—*The Building News*.

USE OF BLAST-FURNACE SLAGS.—At Stuttgart, sand made from blast-furnace slag has recently been used largely for laying on the public promenades. It is found very clean, as it does not get muddy in wet weather, nor very dusty in dry weather. It is brought from the works at Wasseraalfingen, some fifty miles away, and costs 4½ marks, or 4s. 6d. per cubic metre, at Stuttgart, as against 7 to 9 marks for good river sand.

NOTES ON ELECTRICITY AND MAGNETISM.

BY PROF. W. GARNETT.

If the E. M. F. force of the battery be less than that required to fulfil the above condition no permanent current will be sent through the electrolyte. When the circuit is first completed a certain quantity of electricity will flow round it, and if a galvanometer be placed in the circuit the needle will give a sudden deflection, which will continually diminish, and very soon the current will cease. If the battery be now removed, and the electrodes of the electrolytic cell connected directly to the galvanometer, the needle will give a second deflection in the opposite direction to the first, which deflection will gradually diminish, but will not cease until a quantity of electricity has been sent round the circuit by the electrolytic cell in the opposite direction to the primary current, but equal in amount to that sent originally by the battery. Thus the cell has acquired for the moment the powers of a battery, and exerts an electromotive force opposite to that of the primary battery. The cell may be regarded as a secondary battery, and the electromotive force which it exerts is called the electromotive force of polarisation. If before discharging the electrolytic cell the plates forming its electrodes be removed and dipped into a second cell containing the same compound, but through which no current has been sent, it will be found that the plates will have conferred on the new cell the power of sending a temporary current; so that electrolytic polarisation is an action which takes place on the surface of the electrodes, and the electrodes themselves are said to be polarised. The polarisation appears to be due to the deposition on the surfaces of the electrodes of the ions in a nascent condition. It is this electromotive force of polarisation which balances that of the primary battery, and prevents a permanent current being sent through the electrolyte. The E.M.F. of polarisation cannot, however, attain a value greater than the amount of work necessary to decompose one electro-chemical equivalent of the electrolyte.

When the battery is strong enough to send a permanent current, Ohm's law is obeyed equally by electrolytes as by conductors; but the electromotive force in the circuit is not the whole E.M.F. of the battery but the E.M.F. of the battery diminished by the E.M.F. of polarisation set up in the electrolytic cell. Thus if E denotes the E.M.F. of the battery, and e

the greatest electromotive force of polarisation which the electrolyte can produce, and R the resistance of the circuit, the current C will be given by the equation—

$$C = \frac{E - e}{R}$$

When a battery, which is not sufficiently powerful to decompose an electrolyte, is connected with platinum electrodes inserted in the liquid, a transient current passes, polarising the electrodes, and the passage of this current is associated with a transference of the ions to the platinum plates. There is, in fact, no evidence of the passage of any quantity of electricity through an electrolyte unaccompanied by the transfer of a corresponding amount of the ions. But though the transitory current from the battery is associated with the accumulation of the ions upon the platinum electrodes, it does not follow that the battery has performed the work of tearing asunder the electrolyte into its constituents. The molecules of every liquid must be regarded as moving about among each other, the average energy of the molecules being perfectly definite and depending only on the temperature. But though the average energy is definite, the energy of individual molecules may vary without limit, and thus it may happen that two molecules moving with far more than the average energy may come into collision and the shock may split them into their individual atoms. These atoms will move on by themselves until they meet with others with which they can combine, reforming molecules of the electrolyte. The atoms thus separated are said to be "dissociated," and the percentage of dissociated atoms present increases with the temperature on account of the increase in the average energy of the moving molecules. Thus, in every electrolyte there is always a definite fraction of the whole compound in a state of dissociation, and this fraction will increase with the temperature. A battery may, therefore, be capable of separating these ions without doing the work of decomposing the compound. It has only to guide the different constituents to different destinations. If we suppose each atom of one constituent to be electrified positively, and each atom of the other to have a precisely equal, but negative charge, then the electromotive force acting between the platinum electrodes will urge the positively electrified constituent from the anode to the kathode, and the negatively electrified constituent in the opposite direction. This goes on until the accumulation of the electrified ions upon the surface of the electrodes introduces an opposing electromotive force equal to that of the battery, and stops the current. If the E.M.F. of the battery is so great as to allow of the accumulation of the ions in sufficient quantity, the nascent atoms combine into ordinary molecules of silver, chlorine, etc., but this only takes place when the E.M.F. of polarization is equal to the energy developed in the combination of one electro-chemical equivalent of each of the constituents.

When the same battery is employed to send a current through several electrolytes in succession, the E.M.F. of the battery must be equal to the sum of the E.M.F.'s necessary for the decomposition of the electrodes exceeds that necessary for the decomposition of the electrolyte the excess of the work done by the

battery is employed in heating the liquid according to Joule's law.

As all the electricity which crosses and electrolyte has to be carried by the ions, and each atom carries a definite charge, we see at once a reason for Faraday's law of electro-chemical equivalents. Also it is clear that the greater the number of dissociated atoms in a liquid the greater will be the current conveyed in obedience to a given E.M.F., that is, the greater will be the conductivity of the electrolyte. But, the percentage of dissociated atoms increases with the temperature. Hence the conductivities of electrolytes may be expected to increase with the temperature, and experiment proves that they do so in a rapid ratio. In metallic conductors it is the resistance which is increased by increase of temperature.

If a plate of copper and a plate of amalgamated zinc are dipped in dilute sulphuric acid and connected by a wire, a current flows round the circuit, the zinc is dissolved and hydrogen escapes, but the hydrogen is not evolved from the surface of the zinc; it passes through the acid and appears upon the surface of the copper plate thus becomes coated with a layer of nascent hydrogen. When the accumulation of gas on the plate is considerable, bubbles of ordinary hydrogen will be formed, and escape, and the rate at which such bubbles are formed increases with the amount of the gas accumulated on the plate. Hence, if a strong current is evolving hydrogen very rapidly, the amount to be found on the copper plate will be considerable and increase somewhat with the current. The copper plate thus becomes polarised, like the platinum plates described above; it is practically converted into a hydrogen plate instead of a copper plate, and as the E.M.F. of a battery, consisting of zinc and hydrogen plates dipped in sulphuric acid, is much less than that of a zinc-copper couple, the E.M.F. of the battery is correspondingly reduced while the resistance of the battery is increased on account of the layer of badly conducting hydrogen adhering to the copper plate. Thus, the polarization of the plates of a battery reduces the E.M.F. of the battery, but increases its resistance.

Smee reduced the polarization by replacing the copper plates with silver plates coated with finely divided platinum. This battery has a slightly greater E.M.F. than the copper zinc battery, and the particles of platinum projecting from the silver act as point, and assist the liberation of the gaseous hydrogen.

The essential feature of a so-called constant battery is that the E.M.F. is the same, whatever be the magnitude of the current flowing through it, that is, whether the resistance of the external circuit be great or little. It is, in fact, a battery which does not polarise. No batteries are absolutely constant. In experimenting with a certain one fluid battery it was found that when the resistance of the circuit was 10,000 Ohms the E.M.F. was more than 1.6 Volts, but on reducing the resistance and thus increasing the current, the E.M.F. fell, and when the resistance of the circuit was about 10 Ohms the E.M.F. was reduced to 1.2 Volts. There are many batteries in which the polarization is much worse than this.

Some one-fluid batteries, have been constructed in which the hydrogen is employed at once in a secondary chemical action, and is thus prevented from accumulating on the metal plates. The bichromate battery is a

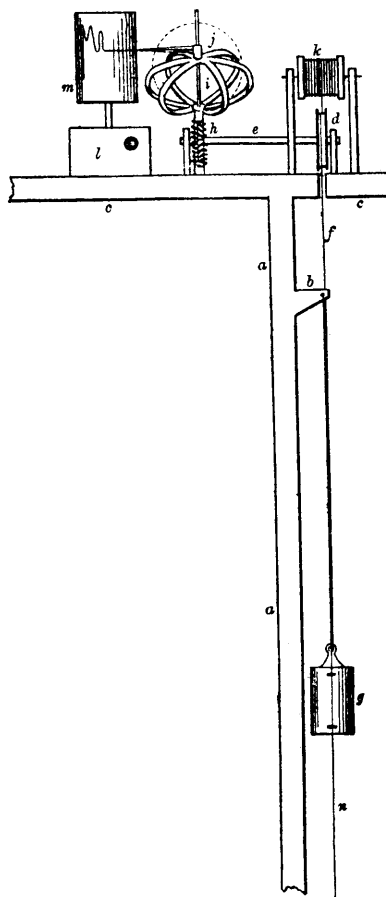

FIG. 5.—Apparatus for registering the vertical component of earth-waves during the whole of the disturbance.

good type of this class. It consists of plates of carbon and zinc, dipped in dilute sulphuric acid, but with the acid there is dissolved a quantity of potassic bichromate. The hydrogen, liberated by the solution of the zinc, reduces the bichromate, forming water and sesquioxide of chromium, and this and the liberated potash, combine with the sulphuric acid, forming chromalum. The hydrogen, is therefore, never liberated in the free state, but at once employed in reducing chromic acid.

A similar action occurs in the batteries of Grove and Bunsen, only nitric acid is employed for the absorption of the hydrogen, instead of the potassic bichromate. It is obvious, however, that while in the bichromate battery, the potassic bichromate may be mixed with the sulphuric acid, it would not do to allow the nitric acid of the Grove or Bunsen cell to reach the zinc plate. The nitric acid is therefore placed in a separate pot of porous earthenware, which is placed in the sulphuric acid. The nitric and sulphuric acids meet in the pores of the earthenware, but their diffusion is very slow. The amalgamated zinc plate is dipped in the sulphuric acid, while a platinum plate in the case of Bunsen's battery, is

plunged in the nitric acid in the porous pot. The liberated hydrogen in its passage to the platinum or carbon plate meets with the nitric acid, reducing it to nitrogen trioxide (which gives the green colour to the spent acid), or to other lower oxides of nitrogen.

The most constant, as well as the earliest of the "constant batteries," is that of Daniell. In this battery the plates are zinc and copper. The zinc is plunged in dilute sulphuric acid, and the liberated hydrogen is employed in decomposing copper sulphate which surrounds the copper plate. In this way, pure copper is deposited instead of hydrogen on the copper plate, and this does not alter the character of the plate, so that polarisation to any great extent is impossible. The electrical properties of the copper depend, however, to a slight extent, on the rate at which it is deposited, and thus the E.M.F. of the battery is not absolutely constant but the cell is by far the best of its kind. As the copper sulphate would deposit copper on the zinc if it could reach it, a porous pot is employed to separate the sulphuric acid and the copper sulphate.

N. B.—From lectures delivered in connection with the Cambridge (Eng.) University extension scheme.