

PER
S
671
C34

THE CANADIAN THRESHERMAN & FARMER

CANADA'S FARM- MACHINERY MAGAZINE

WINNIPEG

CANADA

FEBRUARY, 1913



E.H. Heath COMPANY LIMITED Publishers
OUR ELEVENTH YEAR

JOHN DEERE IMPLEMENTS

SAVE YOUR SOIL

BY BUYING A

John Deere Spreader

The Spreader with the Beater on the Axle



Roller Bearings
Light Draft



SIMPLEST AND STRONGEST SPREADER

NO CLUTCHES

NO CHAINS

NO ADJUSTMENTS

IT has been determined that every bushel of wheat removes soil fertility to the extent of 46 1/2 cents. A 20-bushel crop thus robs every acre of \$9.30. You, as a farmer, must put this back again, otherwise you are playing a losing game. You can do it with a manure spreader. Thus far the question is settled. Now as to the spreader.

THE BEATER ON THE AXLE

IMAGINE a manure spreader without any chains; with all the clutches and adjustments removed; one that has no extra shaft for the beater, no stub axle or counter shafts; one on which the parts that drive the beater all surround the main axle and are within a distance of twelve inches from it; one that, besides being of much lighter draft than any other you have ever seen, is so low down that it is only necessary to lift the manure as high as your hips when loading. Imagine all that and you have some sort of an idea what this new John Deere Spreader is like.

Mounting the beater in the axle makes the John Deere Spreader possible. It does away with chains, clutches and adjustments. It eliminates stub axles and counter shafts that constantly work out of line and give trouble.

It takes all the strains and stresses of spreading off the frame of the spreader and the side of the box. It makes the John Deere Spreader the simplest spreader on the market.

(There are 150 to 200 less parts on the John Deere Spreader than any other spreader made.)

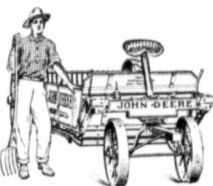

Only as High as your Hips

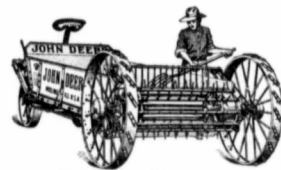

Light Draft and Easy to Load

EASY TO LOAD

The first three feet of manure lifted are the easiest of all. The real hard work begins from that height to the top of the ordinary spreader.

John Deere Spreader sides are only as high as your hips and the wheels do not

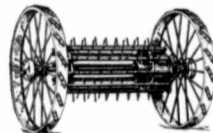

The Beater on the Axle

interfere with the loading. The whole side of the spreader is available for that purpose. You can see where each forkful goes.

The John Deere Spreader is so designed that no adjustments are necessary. There is practically no use for tools. One simple wrench, however, is furnished, and that only for tightening up nuts.

John Deere Plow Company, Limited

WINNIPEG REGINA CALGARY SASKATOON EDMONTON LETHBRIDGE

JOHN DEERE IMPLEMENTS

The Drill That Will Not Clog

With Closed Side Delivery

Easy
On the Horses

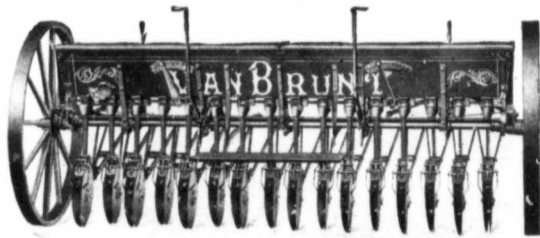

While
Doing Perfect Work

MORE BUSHELS TO THE ACRE

If you seed with a Van Brunt Drill that will effectively seed any soil that can be seeded. Made in sizes 12, 14, 16, 18, 20, 22 and 24. We replace free all disc bearings that wear out.

The Light Draft Van Brunt Drill will help you to increase your yield per acre. Every grain is covered. The seed is deposited near the centre of the disc at the point where the furrow is wide open—not outside the disc circle, after the furrow is closed, as is found on other drills. The seed is not touched or distributed by the upward turn of the discs, but is planted at a uniform depth. Every kernel counts. The Van Brunt deposits and covers them all at an even depth.

The Light Draft Van Brunt Drill has an adjustable force feed device, which compels accurate seeding. Every feed deposits the same quantity in a continuous, even stream. It does not deposit a bunch of seed in one place and then skip a certain distance. Equipped with gear drive makes it positive and accurate, and it can be regulated without changing gears to sow any quantity from a few pounds per acre to the required number of bushels per acre. This is an exclusive Van Brunt feature; you will not find it on any other drill.

THE VAN BRUNT PRESS DRILL

Made in 14-16 and 18 sizes
with 7-in. feed, equipped with
single, double Discs or Shoes

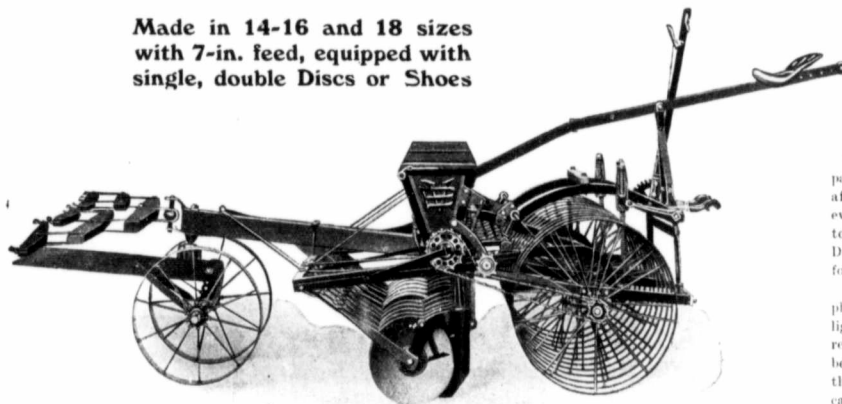

WRITE
FOR
DRILL
CATALOGUE

The purpose of this machine is to pack the soil firmly around the seed, after it has been deposited at an even depth. Where this is required to be done, the Van Brunt Low Down Press Drill is the ideal drill for this purpose.

The equipment of this drill is complete for wear and service. It is light draft and well balanced, with reliable force feed, dust proof disc bearings, automatic device throws the drill in and out of gear. Seat can be adjusted to suit operator.

Get quality and service

John Deere dealers give both

John Deere Plow Company, Limited

WINNIPEG REGINA CALGARY SASKATOON EDMONTON LETHBRIDGE

JOHN DEERE IMPLEMENTS

The only Spring
Pressure, therefore
the only Flexible
Harrow built

Flexibility means
Better Discing and
Better Seed Bed

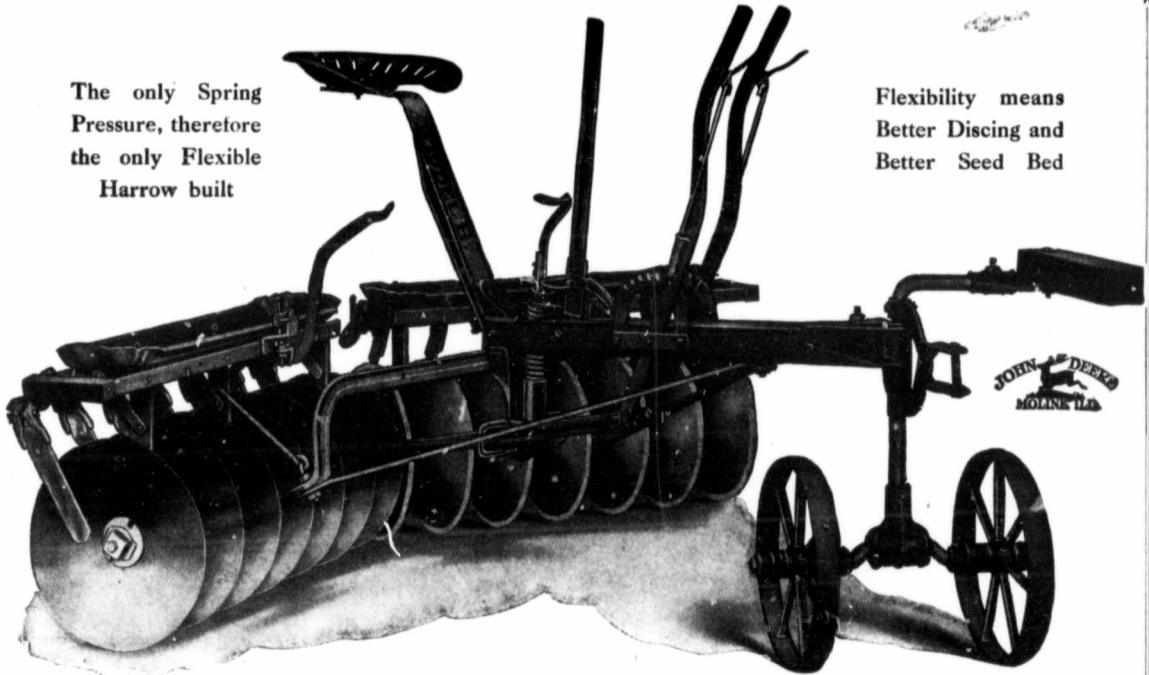

Discing Before Plowing

Something New in Farm Practice

NOTWITHSTANDING the fact that the disc harrow trade has been growing rapidly, the disc harrow is not being put to as many uses as it should be.

Careful study of the following will show that there are enough profitable ways to use this implement, which are not now being practiced, to double the disc harrow trade.

Many practical experiments, and a good deal of scientific study, just recently, has proven the advisability, and in fact, the absolute necessity, from an economic standpoint, of properly preparing the soil before plowing.

Nature stores moisture, in the subsoil, which is brought up to feed the plants by capillary attraction. Capillary is only perfect when the soil is well pulverized and compact—that is, the land must be free from lumps and pulverized so that there will be no large air spaces to retard

the process of bringing the moisture from the subsoil to the seed bed proper.

Stubble, heavy layers of manure, corn stalks or rubbish turned under by the plow, is a hindrance and the capillary water stops at the break made at the bottom of the furrow, consequently the plants suffer because they must depend entirely on the water in the seed bed proper—they cannot get the moisture from the lower subsoil.

This condition is obviated by discing before plowing. The disc not only pulverizes the ground, thereby making a compact contact between the furrow slice and the bottom of the furrow, but all vegetation, manure and trash that was on the surface, is cut up and thoroughly worked into the seed bed.

During seasons of scant rainfall, discing immediately after cutting the grain forms a dust or fine mulch on the top of the land.

It will then absorb water, as well as prevent the escaping of what moisture there is already in the soil.

After grain is cut, the ground is exposed to the direct rays of the sun. This dries the surface, draws out what moisture there may be in the subsoil and leaves the ground hard and dry.

Discing puts the ground in condition for the rapid absorption when rain falls, or the snow melts, thereby preventing washing of the soil.

An intelligent and systematic use of the disc harrow, year after year will greatly increase crop yields. This statement has been verified time after time by the most careful experiments.

Further, in all that has been designed in Disc Harrows, there is nothing that fills the bill so completely for strength, durability and quality of work as the "Deere Model B."

Deere Model B Disc Harrow

The World's Best—The Most Extensively Sold Disc Harrow Made

The exclusive spring pressure on the Deere Model B Disc Harrow insures more even penetrating power and more thorough cultivation. The operator keeps the discs cutting an even depth. The one-piece High Arch Frame and the Solid Steel Gang Frames afford great clearance and extra strength. Deere Disc Blades are of the highest quality of steel and are carefully polished and sharpened. Flexible Spring Steel Scrapers, securely clamped in proper alignment, keep the discs clean without undue pressure. The lock-off device releases the scrapers when they are not needed, reducing the draft. This Model B is easily adapted to a three-horse hitch or a tongue truck.

JOHN DEERE PLOW COMPANY, LIMITED

WINNIPEG REGINA CALGARY SASKATOON EDMONTON LETHBRIDGE

DINING ROOM



Where You Entertain Your Guests

Home is not for its inmates alone, but even if it were, it should be as attractive and artistic as possible. Therefore the decorating of the Dining Room should receive the careful and serious consideration of the home-maker.

SILKSTONE FLAT WALL COLOURS

"Smooth as Silk—Hard as Stone"
Enables the home-maker to produce artistic and permanent effects never before possible. It is the new finish for plaster and metal walls and ceilings. Fine for refinishing burlap. Silkstone is durable and sanitary—is not affected by steam or moisture—may be thoroughly cleaned with warm water and pure Castile soap. Suitable for every wall in the house—takes the place of wall paper and kalsomine. Sixteen beautiful colours and white.

Sold by leading dealers. Write today for free book of "Suggestions"—for paint users.

Everything for the Painter
G.F. STEPHENS & CO. LIMITED
PAINT AND VARNISH MAKERS
WINNIPEG, CANADA
BRANCH AT CALGARY

Mention this magazine when writing advertisers



Seeds

1913 Catalogue Now Ready

80 pages brim full of good things. Contains valuable information for the farmer, market gardener and private planter. 12 pages of the latest and best, world-wide introductions. Valuable premiums. Your choice of 8 new varieties still unnamed (not for sale until 1914) absolutely free with every order, large or small. Don't delay writing. Mail this with your name and address. Your request will receive special attention. State if you grow vegetables or flowers for market, as we have a special price list. Write today while it's fresh in your mind.

**DARCH & HUNTER
SEED CO.,
Limited
Dept. W6
LONDON,
CANADA**



Mention this magazine when writing advertisers

Ladies, Gentlemen's and Children's Clothing,

also furs, positively made to measure. Fully illustrated catalogue free. Prices absolutely below any house in Canada. Medium priced goods, quality and fit are our strong points. We will give 15% discount to all new customers on their first order.

Metropolitan Mfg. Co. Limited.
Toronto, Ont.

Mention this magazine when writing advertisers

ABOUT OURSELVES

WE would like to have you ask yourself and at the same time answer the question for yourself, "How did I like the January issue of The Canadian Thresherman and Farmer?"

We expected to have started our complete programme for the year, but you know around the Christmas holidays, even writers are busy; consequently, we were not able to secure all the material that we had hoped. We are taking considerable pride in our 1913 programme, and although it is costing us considerable money, nevertheless it is our sincere desire to give to our readers, in so far as space will permit, the best that is coming in agricultural literature.

We realize fully that we absolutely depend on our readers for our future existence. It is true that advertising revenue counts a very long way towards keeping up the financial end of a publication, but unless our readers back us up, we are absolutely no use to the advertiser, and permit us to say right here, that from a financial standpoint, the subscription rates would come a long way from paying the necessary running expenses of the publication. We want you to get into the spirit of The Canadian Thresherman and Farmer.

We are attempting to do something different from what has heretofore been accomplished by farm publications. Times and conditions are continually changing. The farmer of ten years ago is not the farmer of today, and a farm publication that does not keep thoroughly in touch with these changes, and in so far as possible gives them to its readers, is not the farm publication that is worthy of your support.

Agricultural editors and managers in most sections of the country seem to feel that because the farmer is obliged to wear a pair of overalls six and even seven days in the week, there is no reason why he is not in a position to enjoy a nice, clean well-printed publication just as well as his city cousin.

It costs money to do these things. There is quite a difference between paying 2½¢ and 6½¢ a pound for paper. When you come to consider that every issue of The Canadian Thresherman runs into several tons, you can realize that this extra increase in the paper bill amounts to considerable within the year.

In 1912 we gave you nearly 600 pages of reading matter. This bound in an ordinary sized book would amount to nearly 3000 pages, which if purchased at the market price would be worth from \$12.00 to \$15.00, while it only costs you \$1.00. Can you, as a practical farmer and man interested in your profession, afford to neglect this opportunity in 1913 by allowing your subscription to expire; and do you not think that you would be conferring a benefit upon your neighbor by showing him your copy? Ask him to look it over, and advise him of the fact that it will only cost him \$1.00. Such an act would help us more than you know, and you would be conferring a benefit upon your neighbor. If you and your neighbor have had trouble over a wire fence or over some trifling difficulty that you feel that you would wish to do him an injury and not a favor, do not show him a copy of this magazine, but if it is your friend as well as your neighbor, then by all means do. Just think it over.

Guard the Home Against Dirt



MANY USES AND FULL DIRECTIONS ON LARGE SIFTER-CAN — 10¢

Mention this magazine when writing advertisers.

Read the Ads and keep Up-to-Date!

Sawyer. Massey Steam Tractors

Built on 76 Years' Experience

We
are not
in a
Combine

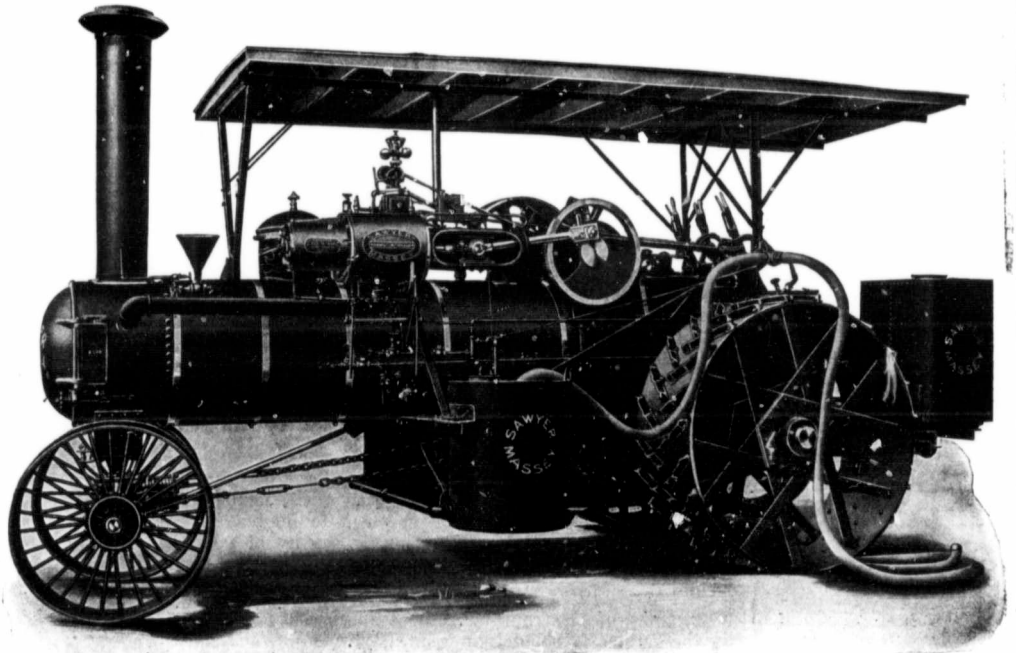

Class C—Compound Traction—Left View
Equipped for plowing with extra Tanks, Siphon and Hose attachment

The few repairs needed and the easy operating qualities of our Steam Tractors save you money. They embody every feature which is essential to the greatest efficiency worked out from actual field experiences in the Canadian North-west.

A few of our specifications are:

BOILERS—Approved by both the Alberta and Saskatchewan Governments and built entirely in our own factory.

FUEL—Will burn wood, coal or straw, as shipped.

GOVERNORS—All engines equipped with improved Waters' Governors.

FUEL SUPPLY—Equipped with sufficient capacity to plow 2 miles or more.

WHEELS—All engines over 22 H.P. equipped with rear wheels 30 inches wide, front wheels 15 inches wide. Extension wheels supplied if required.

Further specifications given in our new illustrated 1913 catalog. We would like to send you for the asking

Sawyer - Massey Co. Limited

Manufacturers of

Steam and Gasoline Traction Engines, Threshers and Road Making Machinery

Head Office and Factory: Hamilton, Ont. Canada

Branches: Winnipeg, Man. and Regina, Sask.

A MAGAZINE FOR THE FARM AND HOME



THE CANADIAN THRESHERMAN AND FARMER

Vol. XVIII. WINNIPEG, CANADA, FEBRUARY, 1913. No. 2.

Place of the Disc Harrow in the New Agriculture

AS THE winds and the waves are usually on the side of the best navigators, so the luck is generally in favor of the best farmer. There are a great many things in ordinary life that, like life itself, are just what we make them. From the same materials one man builds a hovel and another a palace. Bricks and mortar are just bricks and mortar till in the hands of the intelligent builder they are fashioned into a structure of dazzling splendor.

From the same quarter-section of soil one man will scarcely make a decent living, while another will harvest a fortune in less time than it took the ignominious to deplete it of all its fertility. Not only so, but when he has done with it he will hand it over to his successor, pregnant in every square yard with those elements that produce the finest fruits that this old mother earth is capable of yielding.

Half the battle of all success in farming is won when a good beginning has been made on the right foundation. But it is no use trying to raise a paying crop of wheat or corn on soil that never possessed, or has been robbed of, the chemical elements or food that the wheat plant or the corn plant must be provided with. The simple little wheat berry is a wonderful product of nature. It is possible to make something very like it by careful modelling and even to put into it all the chemical properties that the actual seed possesses, but will this product of the laboratory grow?

The principle of life is not yet



Making the Seed Bed
As they did it in 3000 B.C., and as they still do it in British India

in the gift of men, and however eager men may desire to command it, there is not one man who will read this article who will be so foolish as to go on the hunt for it. His business is a simple one, easily understood, and not difficult for ordinary in-

telligence and energy to carry out.

The wheat berry, not having the quality of locomotion, cannot travel around in search of a meal. It must be placed in direct touch with its food, but every one knows that there is nothing in

nature that will more abundantly repay this little service of having "food provided" in sufficient quantity and quality.

In starting to cultivate a piece of land, the first thing a wise man will do is to find out exactly what are the constituents of the land on which he is to operate. As he is probably not an analytical chemist, he may not be able on the instant by digging up a few spadefuls here and there to just find this out. But it can be ascertained at the most trifling cost and it will save an infinity of time, energy and money if he will at the outset find out exactly just what he has got to provide if some vital element is wanting.

Statistics do not always provide the romantic element. They are generally so devoid of interest that it is a weariness to the flesh to study them, but the available figures which tell of the difference in the average yield per acre of staple crops in 1912, and what was harvested twenty or thirty years before on the same farms are little short of astounding. They disclose a most impressive testimony to the advantages of intelligent co-operation with the natural laws in any department of agriculture as against the old, blind, hap-hazard methods of pioneer days when the "book-farmer" was looked upon as the worst form of lunatic the country had to provide for. He couldn't be confined—there was no law to bind him, and for this among other reasons, the "book-farmer" is now the man of the hour and the other fellow is in the asylum or speedily graduating for it.

Not every farmer, indeed not many farmers yet realize to what



Sun-baked after a heavy rain. An excellent condition to lose moisture. Should be thoroughly disced before being plowed

an extent the fate of the crop depends upon the character and condition of the seed bed. Still less do they seem to understand the exact science of nursing and conserving the required elements when they are in the soil, and of

year the depth should be increased until the subsoil is eight or nine inches deep.

It has been well said that "the seed bed is the plant's larder, and it should be deep and roomy." It is the main feeding ground of the

5. If the seed bed is well pulverized, deep and compact, capillarity is perfect. The seed bed should be compact, but not cemented. Seeds germinate very slowly, if at all, in a loose soil, but rapidly if it is compact about them.

EFFECT ON CAPILLARY ATTRACTION

Capillary water will not move upwards in a very loose soil. If the contact between the bottom of the furrow and the slice is not compact, capillary water will rise no higher than the point in the seed bed where the furrow slice meets the bottom of the furrow. Millions of dollars are lost every year simply because stored water is not available on account of an insulation at the bottom of the furrow. If hard lumps, trash, corn stalks, etc., are turned under, air spaces exist to such an extent on the bottom of the furrow that, while the subsoil may be full of moisture, the seed bed is parched. What is the remedy? Disc the ground before plowing, pulverize the lumps until all air spaces are destroyed, work the trash into the soil and then, when the plow

come in contact. Tillage also changes the relations of the soil with the air, the water, the salts and the acids in the soil and makes available plant food elements that otherwise remain dormant. After plant food is rendered soluble, it combines with water and forms a coating around each soil particle. The delicate food-gathering roots wrap around the soil particles and secure the food and moisture by the process of osmosis.

Now if hard lumps exist in the seed bed, the delicate roots are unable to penetrate them, hence they are restricted to the surface area of the lumps, and their feeding territory is greatly lessened. Soil particles are exceedingly small. It requires more than one thousand to make an inch, hence it can readily be seen that, if the lumps are pulverized, the feeding area is increased more than one thousand times. For illustration, let us suppose that a cubic foot of soil containing lumps has an area of thirty square feet. If those lumps are pulverized and the soil particles separated, the feeding area is increased to 30,000 square feet. The writer has often seen land supposedly depleted of plant food made very productive by simply applying common-sense methods of tillage in making the seed bed.

STORING WATER IN THE SOIL

The farmer should not forget that growing plants require water, not in minute but substantial quantities. To insure protection in the event of drouth, care should be taken to store it in the deeper subsoils during the rainy seasons.

As a rule, the absorbing ability of the surface soil depends largely upon its physical condition. Deep plowing and the presence of humus are very important factors and drain tile are very beneficial, due to the fact that the intervening soil between the tile and the surface is always porous.

A hard pan is often formed by

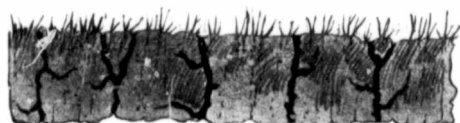

Showing cracks in the land through which moisture escapes

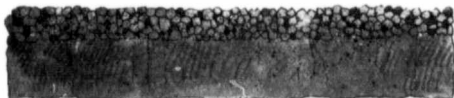

Showing how effectively a Surface Mulch prevents the escape of moisture

knowing just how to place the "bricks and the mortar" in their right relationship to each other.

Taking it for granted that the man who means to make good in farming has taken the precaution to get thoroughly acquainted with his land, to know exactly what the soil does and does not contain, and in what proportions the different elements exist, his next educational step is to know how to handle it.

To get the best out of men you've got to handle them kindly, considerably anyhow, and it is the same with this perennial source of wealth—the soil. Fair and intelligent treatment was never met with greater return than the brown earth will yield in response to kindly and intelligent co-operation on the part of the human element.

There is a half-truth in the old adage that the poor tradesman is in perpetual warfare with his tools; but it is only a half-truth. There is a better "saw" that says, "a hand-saw is a fine thing, but not for shaving with." No man can do excellent work with poor or unsuitable tools, and with ten-fold force does this apply in intensive agriculture, particularly in the preparation of the seed bed.

What the self-binder means in the province of harvesting machinery, it is safe to say the disc harrow has become among cultivating tools. Generally speaking, a deep seed bed is an absolute necessity to the protection of the crop in a dry season, but it is not expedient to plow deeply on certain soils. If the subsoil is sand or gravel and is very near the surface, plowing to a depth that will bring that subsoil to the surface is not to be thought of. It is also known that the humus under virgin sod does not, as a rule, extend to beyond three or four inches below the surface, that depth should be observed at the outset, but each succeeding

plant whence it draws its constant supply of water and oxygen. "The more roomy the seed bed, the greater is the territory from which plants receive their sustenance." The same authority continues:

Plant roots follow the course of least resistance. If the seed bed is shallow, the tendency of the



Was not disced before or after plowing

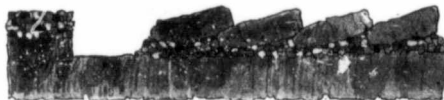

Disced before plowing, making the contact compact between the bottom of the furrow and the furrow slice

root is to spread out, or at least not penetrate below the bottom of the furrow. If the seed bed is deep, the roots are more vigorous and their ability to penetrate greater.

It is a fact well known to thorough farmers that an artificial hard pan is rarely found at the bottom of a deep seed bed. Shallow plowing, however, tends to create a hard pan.

It is safe to say that in sandy, silt and clay loams a deep seed bed of good tilth will produce double the crop that a shallow seed bed will.

Briefly the advantages of a deep seed bed are:

1. Ample space for the growth and development of plant roots.
2. A large store room for plant food.
3. It insures (except in weed land) an abundance of atmospheric oxygen.
4. It acts as a temporary reservoir for water during heavy rains, holding the water until it filters into the deeper subsoils. If the seed bed is shallow, much water is lost by running away.

turns the furrow slice, the contact will be perfect and the capillary water will pass upward into the seed bed.

BENEFITS OF TILLAGE

After the ground is plowed, the seed bed should be disced and harrowed until all lumps are pulverized.

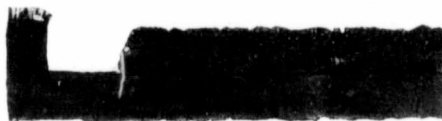

A poorly made Seed-Bed. Disced after plowing but not before. The large air spaces prevent capillary action

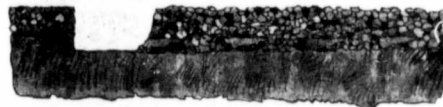

A perfect Seed-Bed, disced before and after plowing. Seed-bed to the left too shallow. NOTE: Soil particles magnified 1,000 diameters

Tillage increases the availability of the plant food elements and compounds found in the soil by changing the arrangement of the soil and bringing together soil particles that have not before

tramping, and the weight of the plow, especially if the plowing is the same depth each year, and it in many cases is absolutely impervious to water. That condition can be remedied by using

a subsoil plow. The subsoiler should not bring to the surface subsoil, nor should it loosen the subsoil to the extent of forming large air spaces, thereby preventing the upward movement of capillary water, but rather than to cut a dash from six to fourteen inches deep below the reach of the plow, thereby permitting the entrance of water and air. Subsoiling is not beneficial in gravel or sandy soil.

CAPILLARY ATTRACTION

Capillarity, or nature's process of bringing water from the deeper soils to the plant roots in the seed bed, is a matter that should receive special attention, and must be thoroughly understood by the farmer who will succeed. Water passes upward, going from soil particle to soil particle and enveloping each with a film of moisture until the surface is reached, where it is consumed by plants or lost by evaporation.

Capillary water will rise from a depth of ten or twelve feet, depending upon the nature of the soil. The process is perfect when the soil is compact and at the same time thoroughly pulverized. The process is materially retarded if the soil is lumpy because of the large air spaces, or when the contact is not compact between the bottom of the furrow and the furrow slice due to the presence of stubble, heavy layers of manure, corn stalks, or other rubbish which is turned under by the plow. When an insulation of that kind is made, the capillary water stops at the break on the bottom of the furrow, and the plant suffers for moisture as soon as the seed bed is dried out.

DISCING BEFORE PLOWING

This condition can be obviated by discing before plowing. The



A straight furrow is not always an insurance policy to a good crop, but it at least denotes careful tillage

disc not only pulverizes the earth, thereby forming a compact contact between the furrow slice and the bottom of the furrow, but all vegetation, manure and trash that may be on the surface is cut up and worked into the seed bed.

In semi-arid regions where it is necessary to store late summer and fall rains, discing immediately after the reaper renders the ground porous, placing it in excellent condition to absorb water, as well as preventing the escape of moisture that may be in the soil, by forming a dust mulch. If the ground is lumpy after plowing, the disc should be used in order that the entire seed bed be pulverized, because the plant food is in the film of moisture that surrounds each particle of soil, and the delicate roots receive food from them by the process of osmosis—hence the more thoroughly the seed bed is pulverized, the greater is the available feeding area for growing and more perfect is capillary attraction.

CONSERVING WATER IN THE SOIL

It is of little use to store water unless some means are used to prevent its escape by evaporation. During the summer the surface of the seed bed bakes and cracks very soon after rains. Experiments have demonstrated that, in one day when the wind is strong and the day is hot, an inch of water will be lost by evaporation unless it is prevented in some way.

Here is where the farmer must use his head. He must close the cracks which serve as escape chimneys and keep the water in the seed bed to nourish the plant roots, and the disc harrow is the ideal tool for this purpose.

A straw mulch does excellent service, but owing to the lack of that material or the great amount of labor required to place it, it is not often used except in orchards, vineyards, potato fields and gardens.

The dust mulch is effective and within the reach of every farmer.

A dust mulch is indispensable to dry land farmers, but is too often neglected by the farmer in humid localities.

The farmer has in his power to save his crops from drouth if he will first store water to provide

against a possible emergency, and form a mulch when conditions indicate that moisture is being wasted.

The illustrations give a very accurate idea of the condition of land on which the disc harrow

and conventions and a Display room for seed grain and grain cleaning machinery, grain picklers, poultry supplies, etc. The whole system is steam heated and equipped with modern conveniences. The equipment represents



DISC HARROW

This implement pulverizes lumps, destroys large airspaces, packs the soil and helps make a perfect seed-bed

has and has not been used in the preparation of the seed bed as outlined in the foregoing observations. They are not elaborated, nor do they exaggerate the case in the least, as any one will find who takes the trouble to test a small corner lot on any field which has been simply turned over and left to take its chance, and that of a piece of acreage in which the disc harrow has been used both before and after a plowman who understands his business has gone over it.



The Manitoba Winter Fair

The dates of this popular Winter Fair are March 3rd to 7th. The Fair will open at 2 o'clock p.m. on Monday and close at 10 o'clock on Friday evening, the 7th. For two years the Fair has been deprived of the regular Winter Fair building. During the past year the Brandon Winter Fair Board has erected a mammoth Live Stock arena on the site adjoining the old Winter Fair building. This arena is one of the largest and most modern structures of its kind on the continent. It is built of brick, concrete and steel with an immense show ring surrounded by promenades and seating for five thousand people. The old building, 325 feet by 120 feet has been entirely remodelled; the entire ground floor is being used for horses and cattle, the upper floor for poultry, sheep, swine, assembly room for Live Stock meetings

a capital expenditure of close to a quarter of a million dollars and is unquestionably the best Winter Fair equipment on the continent with the exception of the Chicago International.

The exhibits of all classes of Live Stock have increased every year since the Fair was instituted and it is expected that the exhibit this year will be almost doubled. A special programme will be put on every night including parade of Live Stock, Horse Show features for High Stepping Horses, Tandems, Teams and Single Horses, Heavy Harness Teams in Six and Four-horse Teams and Single Teams. The railroads have granted single fare rates from all parts of Manitoba and Saskatchewan east from Swift Current. Entries for the exhibition close February 20th. We urge every reader of the "Thresherman" to visit this great Fair which is, without doubt, the "Canada's Great International."



A newly elected Western Senator was pounding his desk and waving his arms in an impassioned appeal to the senate.

"What do you think of him?" whispered Senator Kean of New Jersey, to the impassive Senator Knox of Pennsylvania.

"Oh, he can't help it," answered Knox. "It's a birthmark."

"A what?" "A birthmark," repeated Knox. "His mother was scared by a windmill."



Worry makes a first-class advance agent for the undertaker.



Everything Begins and Ends with the Soil

The CANADIAN THRESHERMAN & FARMER CANADA'S LEADING AGRICULTURAL MAGAZINE

PUBLISHED MONTHLY BY

E. H. HEATH COMPANY, Limited, WINNIPEG, CANADA

E. H. HEATH, PRESIDENT E. W. HAMILTON, MANAGING DIRECTOR F. C. BRAY, TREASURER J. D. DUTHIE, EDITOR C. B. FULLER, FIELD REPRESENTATIVE (MEMBERS WESTERN CANADA PRESS ASSOCIATION)

AUTHORIZED BY THE POSTMASTER GENERAL, OTTAWA, CANADA, FOR TRANSMISSION AS SECOND CLASS MATTER

FEB., 1913

SUBSCRIPTION RATES

Postage prepaid, Canada and Great Britain, \$1.00 Per Year.

Postage prepaid, United States and Foreign Countries, \$2.00 Per Year.

Failing to receive paper, you should notify the office at once, when mistakes, if any, will be corrected immediately.

All Subscriptions must be paid for in advance and are positively discontinued at date of expiration unless renewed.

Advertising copy in order to secure good position should be in our hands not later than the 15th of the month preceding date of issue.

Advertising rates furnished on application

THE ETHICS OF POWER FARMING

WHILE WE ARE IN THE FIELD to watch the progress of farm machinery and the application of mechanical power to the needs of Intensive Agriculture, it is not to be understood that we seek to endorse anything or everything that may be produced in this way and thrust on the market as a "labor-saving" appliance. Still less, however, would we discount the value of any contrivance that might carry a somewhat disappointing record, because there is always the probability that that record has been made while the machine was under the direction of an unskilled operator. That would be like blaming the razor for the "rough sledding" of a bungling barber.

APPORTIONING THE BLAME for unsatisfactory results is often a matter of extreme delicacy; but in many cases the cause is so notoriously apparent that there is no getting away from it. We get "no end" of letters of high praise (or the

and demonstration meetings now being conducted by the great engine builders themselves at many agricultural centres in Western Canada. These facilities are being taken advantage of by the very best of our young farming blood to a greater extent than the general public has any conception of, and the very keen rivalry among the manufacturers gives the assurance that it will end in the "survival of the fittest," or the nearest point in human perfection to which human genius can bring it.

EVEN THEN, "THE END IS NOT YET." It will be an evil day for these fertile prairies when the land-owner settles down to the belief that the millennium of agriculture will come in solely through the application of mechanical power to the single business of crop-raising. The iniquity of this practice is seen everywhere, and one cannot remain blind or indifferent to the disgraceful "scampering" that is seriously palmed off as "farming the land" by men who are handling square miles at a time, not ten square yards of which at any point can by any sophistry be said to have been cultivated.

AN EXPERIENCED OBSERVER is handling this feature of the problem elsewhere in this magazine, so we do not enlarge on it except to say that we are in complete accord with what this contributor has to say, and to express the belief that in time the matter will right itself. There is no difficulty in it that common sense cannot overcome, but leave common sense out of it and all the machinery in the world will not suffice to meet the case. There is everything to hope for, however, and again we say, we have an unwavering faith in the future of power farming.

IF THE OUTLOOK POINTS to anything it is to a constantly increasing market for more farm machinery and better machinery in Western Canada; to a revulsion of feeling in favor of smaller areas, thoroughly cultivated, and in which the live stock end of the game does not play second fiddle to grain growing. This, however, is becoming a wearisome platitude, and the only excuse for its reiteration is the deplorable fact that the principle of diversified farming (the only rational method of using the land) is so habitually violated.

THE PERFECTING OF MACHINERY and its adaptability to every condition to which machinery can be harnessed may be safely left to the natural development of mechanical science, and to the keen rivalry of competitive manufacturers. We are in no worse plight now than the world was in when the first locomotive puffed its way along the crudely fashioned railroad, and when the voice of the crowd was about equally divided between cheers and jeers. But the schools and colleges give the assurance that the day is fast approaching when the supply will be as abundant as it is now short of the demand for men who can handle anything in mechanics that will work in harmony with the laws of Nature.

reverse) of this engine and the other machine. From all sorts of sources we continue to receive expressions either enthusiastically in favor or no less condemnatory of the idea of "power farming," just as it happens to have struck the experience of the observer, and were it not for the fact that we have never had any trouble in getting behind the scenes, our position might have become a very embarrassing one.

WITH UNBOUNDED FAITH IN OUR MISSION, we say in the name of good farming that the most popular and the best advertised labor-saving machine that can be made had better be scrapped before it is a day old if it cannot be trusted to do thorough work. Anything that is attempted in soil cultivation that falls short of this divine O.K. of THOROUGHNESS is so much wasted energy, and is to be condemned. But we know that a great deal of what has become the subject of perfectly justified complaint is due, not to the machine, but to the incapacity of the man who is handling it.

FOR ALL THAT, WE ARE NOT DENOUNCING "the man". Power farming is yet in its infancy. It is little more than three years ago since it was delivered from its embryotic or experimental stage, and in these early days it is no more to be expected that the trained engineer and the specialist in power machinery is to be picked up as required at any employment bureau than one would have expected to find certificated engineers a drug on the market in the same year in which George Stephenson built his "Rocket." "The man" will be found all the same, because there never came a crisis yet in the world's industrial progress in which the man did not arise to meet it.

THAT "ONE HALF OF THE WORLD LIVES IN IGNORANCE of what the other half is doing" was never more true than when it is applied to all the educational work that is quietly going forward in applied mechanics at the colleges, universities, and through the medium of the schools

OUR GUARANTEE

No advertisement is allowed in our columns until we are satisfied that the advertiser is absolutely reliable and that any subscriber can safely do business with him. If any subscriber is defrauded E. H. Heath Co., Ltd., will make good the loss resulting therefrom, if the event takes place within 30 days of date advertisement appeared, and complaint be made to us in writing with proofs, not later than ten days after its occurring, and provided, also, the subscriber in writing to the advertiser, stated that his advertisement was seen in "THE CANADIAN THRESHERMAN AND FARMER." Be careful when writing an advertiser to say that you saw the advertisement in "THE CANADIAN THRESHERMAN AND FARMER."

COCKSHUTT

ENGINE GANGS FOR ALL SOILS

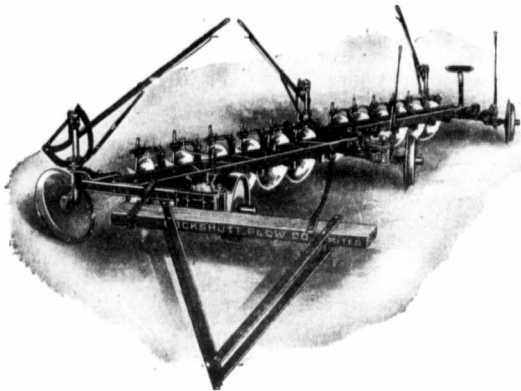

Cockshutt Traction Disc Plow

Aside from the high standard of Cockshutt quality in material and workmanship, there are eight features of this traction disc gang that stand out prominently and mark its superiority over other plows of this type; and they are—

First—The hubs of the discs are fitted with dust-proof ball-bearings and hard-oil cups are provided. These ball-bearings make the discs turn easily and reduce draft.

Second—The use of ball-bearings and the arrangement of the ball races in two circles, one within the other, eliminates the need of cones or other projecting bearings which seriously interfere with the clearance between the discs. The angle of the frame of this plow is such that there is more clearance between the discs than there is on any other plow.

Third—The disc cleaners are straight instead of curved and can not fill up with mud. They can be adjusted to any angle. A great deal of time was spent in perfecting these disc cleaners and they are a decided improvement over any heretofore used on other disc gangs in that they insure a proper moulding of the furrows and thoroughly clean the discs.

Fourth—The two rear wheels on each section are coupled to-

gether with an adjustable rod. This feature makes it an easy matter to adjust the plow to varying soil conditions and insures even furrows no matter how hard the ground is.

Fifth—The plow is hitched to the center of the engine and side draft eliminated. It is also hitched close to the engine, making for light draft.

Sixth—The front wheels steer with the hitch, automatically following every turn of the engine.

Seventh—There is no lever on the front land wheel to interfere with the man who is riding the plow; instead, a simple hand screw leveler is provided for raising and lowering the plow.

Eighth—The plow is mounted on four wheels which distributes the weight to much better advantage than can be done in any other way.

The great strength that has made all Cockshutt engine gangs the most serviceable in the West, is found throughout this plow. Anyone can claim that an engine gang is strong enough, but we will let you judge of the superior strength of this Cockshutt plow. Go to the Cockshutt dealer and examine one, then you will agree with us in saying that it is the most substantial engine disc plow ever built.

Cockshutt Standard Mouldboard Engine Gang

There will be more of these plows in use this year than ever before; and the reason is not far to seek. It is—THE RECORD OF PAST SERVICE. More of these engine gangs will be used this year than ever before because these sold last year and during the many years before have made good to a greater extent than any other engine gang on the market.

Let us again call your attention to a few of the features of this plow that have been largely responsible for its remarkable success.

The independent bottoms conform to all irregular land surfaces; and they also make the plow easy to handle. Raising one bottom in no way interferes with the work of the other bottoms.

The extra wide jaw formed by the two beams of each bottom absolutely prevent winging down.

The frame wheels are set outside of the frame—not under it. This allows more clearance and permits wheels of larger diameter to be used

than can be used on plows where the wheels are set under the frame. This makes light draft and the plow runs level without jarring or jolting. The line of draft is also kept practically the same at all times.

The wheels are extra large, have large dust-proof hubs, wide tires, and removable bushings and arbors. Compression oil cups insure thorough oiling.

The beams, two to each bottom, are straight and will not be twisted out of shape by the toughest sod or by the pull of the heaviest engines.

It has been proved many times that the heavy angle steel frame of this plow has more than ample strength to withstand the hardest usage. Compare its construction with that of any other engine gang and you will readily see why the Cockshutt stands up under the work long after the ordinary engine gang is pulled and twisted out of shape.

COCKSHUTT PLOW CO., LTD.

Western Branches: Winnipeg, Regina, Calgary, Saskatoon

Distributing Points: Red Deer Lethbridge Edmonton Brandon Portage la Prairie

Farming a Section of Land in the North West

BY EDGAR CRERAR.

IN the district of Russell, Manitoba, which is about a hundred and fifty miles Northwest of Winnipeg City, and about eleven or twelve miles from the boundary line between Manitoba and Saskatchewan, a man is sold an half section of land, on which he is going to start farming.

The soil is of a good quality, consisting of a rich sandy loam and humus. The land is rather inclined to be rolling, but not hilly. The above farm has very little scrub or stones on it, and has a general slope to the south. It is well drained and the land dries early in the spring. There will be no difficulty in getting a yearly supply of water at a depth of about sixteen or eighteen feet.

This farm which I have already chosen has very little waste land on it, and nearly all of it is broken with the exception of one or two little sloughs which are located at one corner; with small shrubs and trees surrounding it. This farm is situated along side of the Canadian Northern Railway, with a station on the adjoining section. The town is small, but progressive, and there is a lively trade carried on among the business men.

As this district is not far from the Riding Mountains there will be no difficulty in securing a yearly supply of wood and logs to build his house and stables, which will do him for a few years at first until he is in a better financial position to erect good ones. This farm is not far from church and school to which there is easy access by good roads. The neighbors are progressive and up-to-date farmers.

A man is sold this half section of land with 20 acres broken, and the rest prairie land. As the larger portion of this farm is unbroken it will sell for the same price as wild land which is selling at \$15 per acre, making in all \$4,800 for the entire farm. The agreement drawn up states that he has to pay \$800 down and the rest in ten annual installments of \$400 with interest at 6 per cent.

After making his first payment he has left \$3,000 with which to buy the necessary equipment to start farming. As this young man is a stranger and does not know the ways of Canadians, it might be necessary to offer him some advice. He must first put up buildings and buy horses, implements, household effects, etc. This man is unmarried, and with a sufficient education to run the

business part of the farm together with his daily work. He has decided to run a grain farm. So with these ideas in view, and properly carried out, he should have no trouble in building up a home for himself in this Western country.

First Year

The first thing he did when he went on to the place on the 1st of March, was to hire his neighbor with his team and sleigh to help him get out several loads of logs with which to build a house and stable. When he got his logs out and buildings up, he went to buy implements, and while in town he bought four heavy horses, two sets of heavy harness, a wagon, a set of harrows and a disc, all of which he paid cash for. He went home that day and got his neighbor to go in with him the next day and bring out the horses. When he got his horses home he had to get feed for them, so he bought 200 bushels of oats and 4 tons of hay from one of his neighbors. A few days after he went back to town and brought home his implements, and household effects, etc. He was then pretty well settled down and ready to start his spring work. Before starting seeding he hauled his hay and oats home from his neighbor's. He was then ready to go ahead and put in his crop, so he disced his breaking and harrowed it two or three times before sowing. When ready to sow he borrowed his neighbor's drill and sowed it, putting on 2½ bushels of oats per acre.

After seeding he went to town and bought enough wire to fence the whole farm, as there was lots of willow near by he used willow fence posts. He hired a man for a few days to help him. After he was done fencing he went to town and bought a sulky plow with breaker attachment. Then he started to break and broke 2 acres per day for 35 days which made 70 acres in all broken. While he was breaking he used three horses, and the other mare ran on the prairie with a foal.

During the summer he hired a carpenter to help him build a machine shed and granary combined, which was 24 feet by 30 feet with an upstairs in it to hold grain, and the lower part for implements. Having got his shed built, he started haying, his neighbor and himself working together. Harvest was drawing near and he had to get twine to cut his crop, so he went to town

and got his twine and some provisions for the house. He borrowed his neighbor's binder to cut the crop as his crop was small the first year it was not necessary to buy one. After cutting his crop he stooked it, and then started discing until threshing started. He went out in his neighbor's gang with one team, while the other team was on pasture. He threshed for 32 days at \$4.50 per day. He then got the machine to thresh him out of the stook which took half a day. His crop turned out good, having off the 20 acres 1600 bushels, costing 3½ cents per bushel to get it threshed. After threshing was done he repaired the buildings and got things in shape for winter, as it was already frozen up. Before the snow came he went to town and bought a set of sleighs. He lent one team and the colt to his neighbor during the winter for the use of the team. He took the other team himself and went back to a lumber camp and took out some lumber. Coming on towards spring he came home from camp to haul the remainder of his grain, and some wood before the snow should go away. He hauled home his lumber also. He sold 1000 bushels of grain for 35 cents per bushel which brought him \$350. This found him at the end of the first year, so after paying taxes and making payment on farm he totalled up his books, and found that they credited him with \$811.

Cash Account

Dr.	
To horses and harness	\$1000.00
To wagon	100.00
To harrows	25.00
To seed and feed	80.00
To wire	45.00
To sulky breaker	45.00
To machine shed	450.00
To twine	5.00
To threshing bill	56.00
To neighbor's bill	60.00
To svt sleighs	37.00
To taxes	40.00
To sundries	100.00
To payment on place	640.00
	\$2682.00
Cr.	
By cash on hand	\$3000.00
By money earned	144.00
By grain sold	350.00
	\$3494.00

Second Year

He was then ready to start spring work the second year, but before starting seeding he got his horses home, cleaned his seed and feed grain and sawed and split his wood. He was then ready to start plowing the 20 acres that he had in crop the previous year. He had to disc and harrow his breaking a couple of times before



Early Productive Varieties

- Wheat, Marquis
- " Dr. Saunders' Early Red
- " Siberian
- " Orloff (earliest of all)
- " Sauer Registered
- " Improved
- " Abundance
- Barley, Six Rowed
- Buckwheat, Silverhull
- Speltz
- Fodder Corn
- Tares or Vetches
- Flax, New Premost (early)
- Field Peas
- Essex Rape
- Grasses, Bromes
- " Western Rye
- " Bromes and Western Rye
- " Mixed
- " Timothy
- " English Blue
- " Common Millet
- " Siberian Millet
- " Hungarian Millet
- Clover, Red, Medium
- " Mammoth
- " Alsike
- Alfalfa, Northern Crown
- " Grimm's (Genuine)
- " Turkish
- Vegetable and Flower Seeds
- Field Root Seeds
- Planet Jr. Garden Implements
- Blatchford's Calf Meal
- Bitter Lick Salt Brick
- Oyster Shells and other Poultry Supplies
- Spraying Machines

"How to grow the Best Vegetables, etc."

11 Booklets, 153 pages, copy-righted. Price 10c each, or full set of 11 booklets for \$1.00 but FREE TO CUSTOMERS. Send to-day for our Catalogue—FREE TO ALL.

STEELE, BRIGGS SEED CO. LIMITED
WINNIPEG, CANADA
CANADA'S GREATEST SEED HOUSE



Mention this magazine when writing advertisers

Have you renewed your Subscription?

it would be in shape to sow. He went to town and bought a 16-shoe drill; then he sowed his crop putting 2½ bushels per acre. After seeding he went to town and got wire to fence a small pasture field off one corner of the farm; for the horses to run in the summer time when not working. Having done this he spent thirty-five days breaking, during which time he broke 80 acres. He then took off some stones and started discing his breaking. After he got the breaking discd he found it was time to start haying, so he hired a man for three or four days to help him get up the hay. He hired the man for three months at \$35 per month until after threshing. Before he started haying he went to town and bought a mower and horse-rake. After haying he started the hired man discing the breaking again. He found that his crop was going to turn out well and it would be necessary for him to build a granary. So he got the material on the ground, hired a carpenter for a few days to help him build it. After the granary was completed he went to town for twine, and bought a new binder. It was then time to start harvesting, so he cut the crop and stooked it. After harvest he put the hired man harrowing the breaking until the stooks were dry enough to stack. After he had the crop stacked he got the machine to thresh him. His crop turned out well the second year, averaging 65 bushels per acre all around and making in all 90x65=5850 bushels of grain at 3½ cents per bushel for threshing it. He got his neighbor's wife to do the cooking while they were at his place. After threshing, his hired man left him, and he started plowing and plowed till it froze up. After it froze up he found it necessary to haul out some of his grain to pay bills that were coming due about then. So he hauled out (1,800 bushels) or one carload of oats at 35 cents per bushel, for which he received a handsome check of \$630. It was then winter again, so he lent his one team and two colts to his neighbor for the winter's use of the team, and he took the other team and went back into the lumber camp to finish taking out the lumber for his new barn which he built the next year. He spent the winter in the camp until about the middle of February, then he went home, took out his wood and a carload of grain (1,800 bushels at 36 cents per bushel). It was then getting close to the first of March and he had his lumber to draw home, and saw and split his wood. He paid his taxes and payment on the place. This brought him to the end of the second year. So he balanced up his books to see how he was coming out.

THE PIONEERS

FIRST IN WESTERN CANADA

In Point of Time—

BECAUSE WE BEAT THE RAILWAY

In Leadership—

BY BEST BUILT MACHINERY

The first robin will soon be here and then you'll want that

MASSEY-HARRIS

New "Great West" Plow

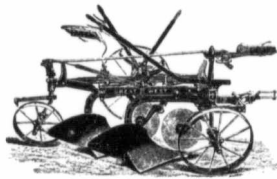

A New No. 11 Drill

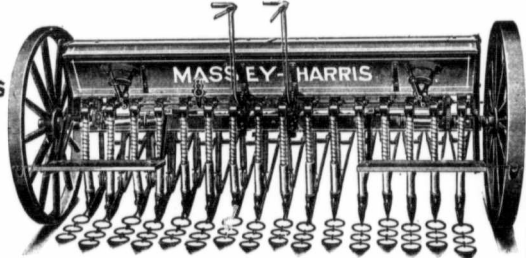

AND A "Best Ever" Cultivator

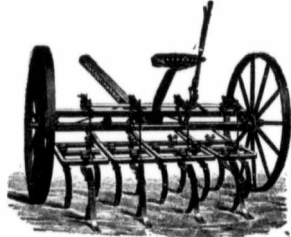

Be in the front ranks of Prosperity's troop by using prosperity producing farm machinery. See the MASSEY-HARRIS Agent and order NOW.

GRAIN BINDERS
CORN BINDERS

REAPERS
FEED CUTTERS

MOWERS
RAKES

HAY TEDDERS & LOADERS
MANURE SPREADERS

DRILLS
DISC & DRAG HARROWS

FIELD CULTIVATORS
CORN CULTIVATORS

CREAM SEPARATORS
GASOLINE ENGINES

HORSE GANG PLOWS
ENGINE GANG PLOWS

DISC PLOWS
DISC ENGINE GANG PLOWS

SULKY PLOWS
WALKING PLOWS

ROLLERS
LAND PACKERS

WAGONS
SLEIGHS

LORRIES
DUMPCARTS

MASSEY-HARRIS COMPANY, LIMITED

Farm Machinery Manufacturers to 500,000,000 of people

SCUFFLERS

WHEELBARROWS

GRAIN TANKS

AUTOMOBILES FOR THE FARMER

TO many of us it seems like yesterday when we stared at the "greatest thing of the century"—the new horseless carriage, the first motor car (for the word "Automobile" had not yet been coined.) It was a wonderful sight and to our boyish imagination eclipsed all we had ever seen either in visible machinery or invisible magic.

To the wisecracks of the day the thing was a nine-days' wonder, a freak of some crazy conception, a silly and very expensive toy, designed and constructed by some fellows who had more money and time than they knew what to do with, but to the serious rank and file such a thing could have no practical value.

"Replace the horse!" Never in this world however long it might last! And just there the prophets were right, for it will never oust our four-footed friend from the economy of nature in general, and our social environment in particular. What has happened in the interval scarcely needs telling, but

it is just this: the horse is of greater value and is in greater demand today for that reasonable and legitimate position it was

at the time predicted the scrap heap as the only fate of the "Motor car," a very sad picture looms in sight. We think of "Derby Day"

right under their gingham or sheltered by the awning of the more aristocratic "house party in the drag" with their abundance of liquid refreshment.

But what of the dumb creatures of flesh and blood that took them there—ten to a dozen fat women and corpulent city gentlemen to one horse? They were forgotten in the sweltering heat until a half-way house was reached when, more for the delectation of the mob they carried, a brief halt was made for more liquor and the poor brutes were given a perfunctory sponge down and a cup-full of tepid water to slake their thirst.

This is no exaggerated picture, and there are yet young men who recall it with all its humanity and criminal thoughtlessness. But what a change has come over things since then! In those days the horse on the street or toiling under its crushing burden along the country road was no more the subject of commiseration than is the Auto-truck of our city streets today. In this age, however,



Lunch by the Wayside

"designed and built" to fill in the service of man.

As we think of the old days when the concentrated wisdom of

and the hundreds of thousands of cold blooded sinners being rushed to Epsom, along dusty roads under broiling sun. They were all

Hupmobile TOURING CAR

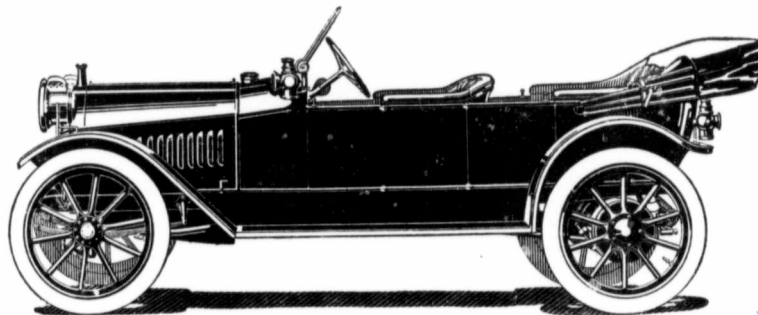

The man with the Motor car gets to town whenever he wants to.

The man with the Motor car gets to town whenever he wants to.

Price \$1,150.00 f.o.b. Windsor, Canada

You may think you don't **want** a Motor Car but there isn't any question about your **needing** one. After the day's work—turn the horses loose, allow them rest. In the evening use your motor car for a spin to town with your family aboard.

There are many good cars made nowadays, but the Hupmobile offers the best value for the money of any on the market. Compare them with others--the new models are now on exhibition at all dealers. We have a brand new catalog--write for it.

JOSEPH MAW & CO. LIMITED
WINNIPEG

Distributors for the Hupmobile, Paige-Detroit, Chalmers, Peerless, and Firestone Columbus

You saw this advertisement in this magazine. Don't forget to say so when writing.

McLAUGHLIN-BUICK

1913 Models will be exhibited at the

Winnipeg Motor Show, Feb. 10 to 15, 1913

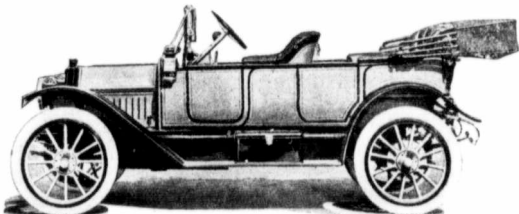

Model 25

Compare them with the leading models and you will find McLaughlin-Buick Outstanding Features of **STYLE, FINISH, MECHANICAL CONSTRUCTION and PRICE** are ahead in all values. The old McLaughlin Policy of Superiority, Long Manufacturing Experience, and Knowledge of Canadian Conditions, has enabled them for the past forty years to place a product on the market that has **ENDURANCE and RELIABILITY** stamped in every detail of the **FIVE MODELS, TWO ROADSTERS, THREE TOURING CARS.**

Model 40-40 h.p. TOURING Car—Complete in every part, electric lighted, self starter, \$2440 Winnipeg.

Model 31-32 h.p. TOURING Car—A popular touring car with all the latest improvements including dynamo electric light system, with all the latest refinements, \$1900 Winnipeg.

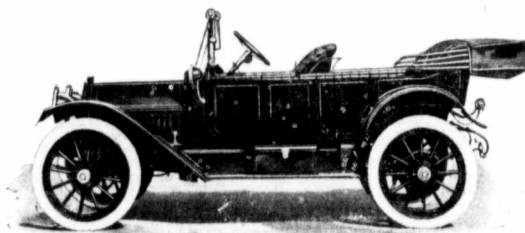

Model 31—Five Passenger Touring Car—\$1900, Winnipeg

Model 25-26 h.p. TOURING Car at \$1510 Winnipeg is in a class by itself and worthy of close investigation. **THE ROADSTER MODELS** embrace a 32 h.p. and 26 h.p. at \$1750 and \$1300 respectively, are of new design and graceful lines. Make a close comparison of these with any similar line.

THE PIERCE ARROW—THE CAR OF DISTINCTION

If you want to pay the duty, here is a car that is in a class by itself. Combines the highest skill in design and mechanical construction. It will be one of the features of the show.

SHOW SPACE, Centre East End Upper Floor

At the Warerooms, Princess Street, a more comprehensive display of McLaughlin-Buick cars are on exhibition. You will be welcomed and given every attention. Be sure while in Winnipeg at the Bouspiel to call at

McLaughlin Carriage Co. Limited

204 Princess Street

WINNIPEG

You saw this advertisement in this magazine. Don't forget to say so when writing.

there is nothing more revolting to the average citizen than a horse, of all creatures, laboring under the least inconvenience or pain that can be alleviated.

What, perhaps, as much as anything else has ushered in this day of reason and consideration for the horse? The Automobile. No doubt the trend of human progress is upward as well as forward, and apart from any outside influence, our educational system is all in the direction of inculcating these softening traits in men's hearts that make for kindness and thoughtful reward for every living creature.

While the rudely fashioned "Motor Car" has developed in less time than a quarter of a century into one of the biggest industries on earth, who will say that the value of horse flesh has depreciated, or that at the same time there has not been an equally sensible betterment in the quality and number of pure-bred and standard-bred horses? And the progress in both cases will continue as long as night and day follow each other and new men and women are born into the world.

There is another feature of surpassing importance to our national life which the automobile industry has been directly responsible for—the improvement of the public roads. What our country roads and prairie trails were but a few years ago cannot be likened to anything else, for we know of nothing else in Western Canada that would enable us to complete a comparison. Even now they are notoriously bad in many places, but the "good roads" mission work that is now in progress, we believe, will mean within the next few years probably as great a

revolution in its own way as that of the life-history of the automobile itself.

The future of the automobile industry depends on what will be done in facilitating our "lines of communication," not only in and around the centres of population (which may be safely left to take care of themselves) but more particularly to the great highways which will form, so to speak, the grand trunk lines or main arteries that will run from coast to coast,

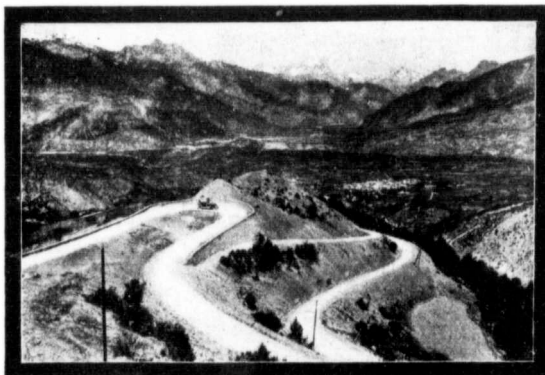

In the Valley of Dumne

and to the north and south wherever the needs of traffic call them.

At the present moment, the landscape glories of Canada are little known except at those points which are cut by the railway systems, and then the passenger has only the opportunity in taking it at a flash from the carriage window, or from the platform of the observation car. The "Rockies" as they may be viewed from the track of the Canadian Pacific Railway, unfold a panorama of natural grandeur which can never be forgotten and is perhaps un-

surpassed by anything of the kind we yet know of.

But no one can be said to have seen the Rockies or to have obtained a real conception of their constantly changing splendour and infinite variety of rock and river, of green carpeted hills and matchless timber wealth who has only "done" it from the window of the dining car.

The "Rockies" do not by any means represent all there is of Canada's wealth in fine scenery

Canada has yet to be explored and we are as certain as we are of existence at the moment, that more than by any other means it will be accomplished through the medium of the automobile. In the nature of things, a railway train whatever its ramifications may be, is "cabined and confined" to a certain number of miles of lineal space from which it cannot be diverted, unless you ditch it! but an automobile may become ubiquitous.

The man who loves his horses will be the first to buy an automobile because on the top of the saving to horse flesh and the consideration due to the animal, the automobile will save the man's time enormously. It carries the man or the parcel to the desired place in less than half the time that the horse will take while it brings the farmer into close touch with the city since twenty miles with an auto is equal to six a horse.

The automobile is here to stay and when you see a man who tells you what is going to happen if this benzine buggy craze does not stop, he is the one who is getting ready to purchase.

Good roads mean progress, prosperity, and benefit to the people using the city, and advantages to the people who live in the country. Good roads help all alike, like good streets. Good roads mean prosperous farms, bad mean abandoned farms, sparsely settled country districts, and congested over populated cities.

With the advent of the automobile all this is changed, and soon you will find the city cousins being visited by the country cousins, and vice versa through the means of rapid transportation by the automobile.

and exquisite holiday retreat nor do they in many respects lead us to the best of it. The words of Gray were never more true of anything under heaven than they are of this choice bit of the North American Continent we call "Canada."
"Full many a gem of purest ray serene
The dark, unfathomed caves of ocean bear,
Full many a flower is born to blush unseen
And waste its sweetness in the desert air."

GASOLINE TRACTION ENGINES

A DEPARTMENT FOR THE USER

We want every owner of a gas tractor in Western Canada to give us his experience. The owners of gas tractors to-day are in a sense pioneers. They are working out the data and compiling a record of work done that both manufacturer and farmer alike the world over are watching with intense interest. Don't keep what you know under your hat, but let us have a story of your gas tractor work. We will reward every such story with a copy of "Plain Gas Engine Sense," one of the best handbooks we know of on the gasoline engine. Don't neglect this matter but let us have your experience at once.—(Editor.)

Believe in Power Farming

Your letter to hand asking for my opinion and experience regarding the traction engine on the farm.

When we moved on to this farm two years ago, we had no seeding to do as the crop had all been sown, about 600 acres. We are farming one and three-quarter sections, and as it is all under cultivation with the exception of about 100 acres, we had a considerable lot of summer fallowing to do. We talked the matter over as to whether it would be more advisable to buy horses or a tractor, and decided to buy a 25 h.p. gasoline tractor.

The manager of the International Harvester Co. advised us to take a 45 h.p. instead of a 25, which we did. We got one of their 45 h.p. double opposed engines, and were glad afterwards that we had taken his advice, as we can do so much more work in a day with it than we could have done with a 25 h.p. engine.

We use an eight-furrow plow, with 14-inch bottoms, but should have had a ten-furrow plow instead as our engine was capable of pulling ten bottoms. The first year it averaged 55 cents per acre for gasoline and engine oil and 18 cents per acre for cutting our crop. We used the engine for cutting all our crop. We were then paying 20 1/4 cents per gallon for gasoline and 45 cents for oil.

We pulled three McCormick 8-foot binders, but we could have pulled another binder for very little extra expense.

Now you might like to know how these binders worked behind the engine. I must say they did excellent work in all kinds of grain with the exception of flax. The speed was not fast enough to do good work in flax, but I understand now that the International

Harvester Co. have made a larger drive sprocket for the binder, which gets over this difficulty.

This year we plowed about 680 acres and cut 870 acres, and threshed 23,000 bushels of grain, and used \$615 worth of gasoline, engine oil and cup grease. As a rule we use two men when we are plowing, one on the plows and one on the engine. It keeps a man busy on the plows as we run a packer and harrow behind the plows, and to keep all these clean

and leave something like a surface paper.

I consider that the tractor has the horses beat for hard work on a farm, especially for plowing. The hotter the day, the better your tractor will work, which is not so with the horses, and you can work as long as you like.

Our engine travels two miles an hour plowing.

I think I have given as much as is necessary in this letter, and if there is any other things you

kerosene to break an acre in this scrub, which costs less than \$1.00 an acre for kerosene. We think that breaking with a traction engine is much cheaper than with horses, and certainly much easier on horse flesh.

In plowing stubble, we use two sections of Emerson Disc Plows with fourteen discs cutting ten feet wide, which is about the right load for our engine, and it does a very satisfactory job, especially in back-setting, as it does not choke up in this rooty land as the mold-board gang does. Stubble plowing takes about two gallons per acre, or about forty cents per gallon, which we think is cheaper than can be done with horses.

One item of saving with an engine is that it takes less men, and that is quite an item here, where help is scarce.

Our engine uses about two barrels of water a day for cooling purposes, and we have a tank for

hauling kerosene in, we do not use horses more than one day in the week to supply our engine.

As for discing and harrowing, we can double disc and double harrow at a cost of about 25 cents per acre, which we think is very much cheaper than can be done with horses. We have had no experience for seeding and harvesting, as we use horses for that work. As for the engine wheels packing the ground, and having a bad effect, we have been unable to see any difference in the growing crop.

We have a 30-42 Aultman & Taylor Separator with self-feeder and wind stacker, and high weigher, which we think is second to none for easy running and fast work, and for doing a very clean job.

We thresh our own crop, and are also out a short run each season. We think this size of separator is the right size for our



Doing a nice, even job in Saskatchewan

and not let them get clogged up keeps him busy.

The gasoline has a big advantage over the steam engine in the water question, as we use just 1 1/2 to 2 barrels a day.

We have never used our engine for seeding, simply because we considered it more profitable to keep the engine plowing, and let the horses seed. We can plow so much deeper with the engine, and do so much better work. Some people think that a tractor weighing about 18,000 lbs., going over the plowed land when seeding or harrowing, packs it too solid. This is not so with my experience. It works more like a subsoil packer, as the dogs on the wheels sink deep in the ground, but the balance of the wheels do not make much more impression than an ordinary roller; as the wheels go round, the dogs lift, or rather break the surface part of the soil,

would like to know, I will be very too glad to answer them.

I am, Yours respectfully,
W. M. Shiniff,
Manor, Sask.

February 1, 1913.

Requires Less Men

We own and operate a twenty-five horse power I.H.C. Mogul Junior kerosene tractor engine. This engine is a single cylinder throttling governor type.

We think that this engine is about the right size for a farm of about a section, and also is not too heavy to pack the ground to any extent.

This part of Saskatchewan is chiefly covered with scrub, and in order to break it we have to use heavy brush breakers. We use a John Deere brush breaker, two 24-inch, attached to an Emerson disc frame, which makes an excellent outfit for this kind of work. It takes about four gallons of

S
 oners
 nterest
 in Gam
 Editor.)
 re in this
 han \$1.00
 We think
 nction en-
 han with
 ch easier

e use two
 sc Plows
 ting ten
 the right
 d it does
 specially
 does not
 and as the
 ard gang
 Stubble
 takes
 wo gal-
 acre, or
 ty cents
 n, which
 nk is
 han can
 with

tem of
 with an
 that it
 s men,
 is quite
 here,
 elp is

ngine
 ut two
 water
 cooling
 and we
 nk for
 do not
 day in
 ine.

owing,
 double
 5 cents
 s very
 e done
 ad no
 d har-
 or that
 wheels
 ving a
 nable
 grow-

an &
 feeder
 high
 econd
 d fast
 clean

, and
 n sea-
 e of
 or our

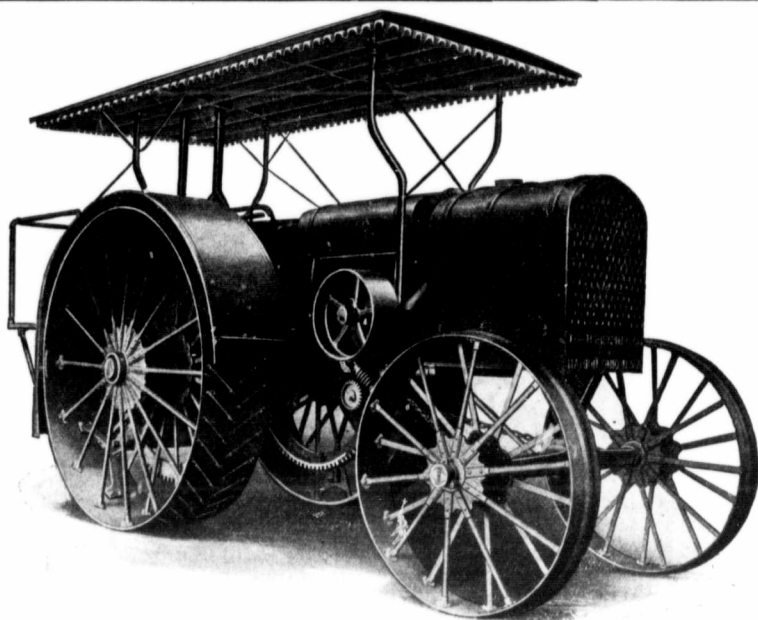

HUBER GASOLINE TRACTOR

*A Four
 Cylinder
 Tractor
 Built for
 Heavy Work*

If you have hard traction or belt work to do, and prefer the internal combustion engine, you owe it to yourself to investigate carefully the merits of this outfit. It has features that will interest you and save you money.

The consumption of fuel is very light compared with the amount of effective power developed. The gearing is finely adjusted for transmitting power with the greatest economy. For belt work, there is a wide band pulley placed at side of frame and close to motor. In setting for stationary work, engine is backed into the belt without band wheel turning; and this is found very convenient by the thresherman. The outfit has special advantages for traction work. Its width does not interfere with its use on ordinary roads. The weight is distributed, and draw bar pull adjusted, so that the engine has enormous pulling power. The drive wheels are high and wide, giving a powerful grip on the ground. This is an attractive feature in hauling over soft ground or sand, and in plowing.

The Huber Thresher is a machine that will make money and friends for you. It has great capacity for work. Fast and clean threshing is characteristic of this machine. When you thresh for a man once, he is sure to want your machine to do his work every year.

A new feature is the automatic oiling device for cylinder boxes. All the attention the boxes need is to see that the large oil pot is kept

supplied with oil. The gravity feed will do the rest and relieve you of all care of cylinder boxes.

We cannot give many details here. Our catalog gives them all. We have one book telling about our steam engines and threshers; and another describing the gas tractors. Either or both are mailed promptly on request. If you haven't yet received a copy, ask for one today.

The Huber Manufacturing Co. MARION, OHIO, U.S.A.

Canadian Branch: Corner Logan and Arlington Streets, WINNIPEG, MANITOBA.

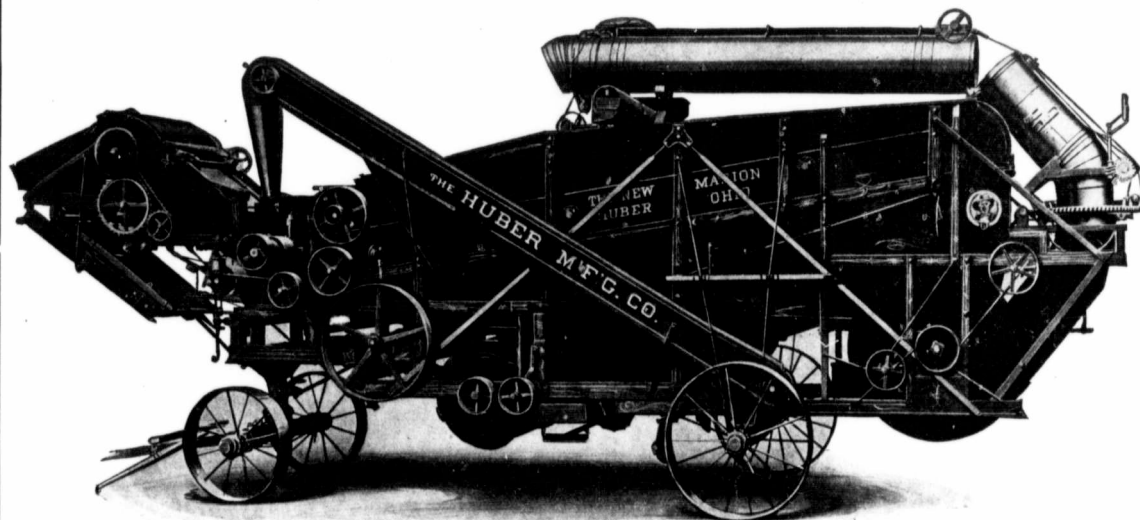

HUBER COMPLETE THRESHER

You saw this advertisement in this magazine. Don't forget to say so when writing.

Gaswell Power Farming Equipment



Harness your iron horse with a CASWELL HITCH, a DISC and SEEDER HITCH, and then a BINDER HITCH. We are also manufacturers of the famous Caswell Adjustable Belt Guide, Engine Wagons, Packers etc.

Write us today for catalog and prices.

CASWELL MANUFACTURING COMPANY

CHEROKEE

::

::

IOWA



You saw this advertisement in this magazine. Don't forget to say so when writing.

engine, especially here as the straw is long, and is usually cut a little on the green side. We can generally thresh 1,200 bushels of wheat, or 2,000 bushels of oats in a day of ten hours with about 30 gallons of kerosene.

We also do our own crushing, and do custom crushing one day in the week during the winter. We have a Rapid Easy 12-in. plat crusher, with which we crush about 350 sacks a day of mixed grain.

We have generally been very fortunate as to breakdowns. Our experience for breaks for the past season amounts to 80 cents.

We think that traction farming is a success when the rig is properly looked after, and is cheaper for the reason that you can run 24 hours a day which is an impossibility with horses. It also means getting your work done more quickly, and your crop in earlier, which means an earlier harvest, and that means money especially when an early frost occurs during harvest.

We think the Canadian Thresherman and Farmer an excellent magazine for farmers and we would not like to be without it.

Hoping this will be of some use to you, I am,

Yours truly,

J. A. Scott.

January 30, 1913.

Power Cultivation Profitable

In reply to your letter requesting my opinion of farming with engine power, I have a great deal to say, but I will have to reduce it to a summary in this letter. My knowledge is not limited only to our own experience, but to a number of large farms here in the Northwest that are operated exclusively by engine power, and probably one of the most favorable examples is our own.

We will take for example our Rumely, twenty horse power, two cylinder opposed gasoline engine. This engine is, in my opinion, a very serviceable machine and it works under full load with a minimum consumption of fuel.

It is an engine that is built apparently under the latest me-

chanical advice, and from a business standpoint it is a money maker for the farmer as well as being simple enough of construction to enable the ordinary farmer to understand it.

Working under ordinary conditions this engine burns two to two and a half gallons per hour, but usually one is inclined to load an engine down with all it can carry so that the fuel consumption is increased about thirty per cent.

The engine uses about six quarts of lubricating oil in an ordinary ten-hour day as well as two pounds of hard oil and two quarts of gear oil. This engine is force oil feed throughout thus avoiding any trouble through neglect in this direction.

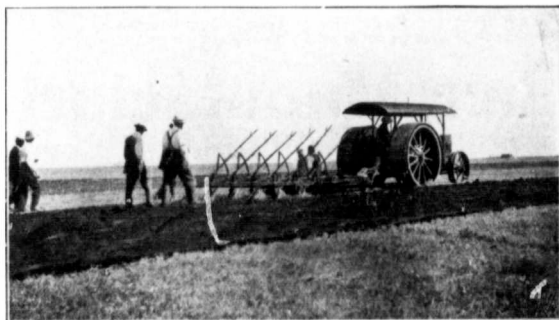

Watching the Results at the Winipeg Motor Competition

Regarding men and horses required to work our engine, I can say that the expense is comparatively small. It really requires two men on the outfit when doing any kind of plowing or cultivating, but it is perfectly possible for one man to operate both engine and plows or other implements as the case may be. We only require the use of a team every second day to haul gasoline and oil, for we have a tank used to haul fuel. The only time the team is otherwise required is during cold weather when it is not safe to leave the water in the radiator over night and the team is used for hauling fresh water every morning.

I consider it costs me approximately \$1.30 to plow, \$2.00 to disc and 25 cents to drill an acre of

land, including fuel, help, and depreciation of machinery.

I find that it is very convenient as well as economical to use power of this kind to cultivate; first, because it can be kept constantly in operation during rush seasons, and secondly, because it does away to great extent, with the trouble of locating competent farm hands. And when properly handled a tractor does far better work than horses ordinarily do.

Regarding the use of an engine on plowed land, I believe it is all right at any cultivating work except harrowing soft plowing. The objection is that the wheels sink into the ground and the harrows haven't enough weight to loosen the earth again. However, this

is easily remedied by taking two discs and removing enough discs on the outsides so that they will cut the same width as the drive wheels and set them directly behind the drivers, thus loosening the earth to its original consistency.

However, this is a small item and as a practical investment for the man who is farming on a big scale, I believe he cannot beat a good traction engine.

Sincerely,

Albert V. Hammett
Mgr., Hammett Farm,
Elbow, Sask.

January 30, 1913.

Trouble in Wet Land

Your letter of recent date is before me in which you request

my experience in traction farming.

I purchased a Hart Parr 30, 60B. h.p., in the season of 1911. It landed in Saltcoats and was unloaded September 1st. As I was very busy harvesting at that time, I got the expert to take the engine out to my farm the same evening after unloading. It was a distance of 12 miles, and we landed home in the wee sma' hours, after waking up all the people along the road.

I put in the next day receiving instructions from the expert and getting a little practice as I had never handled a tractor before, although I had some experience with a portable engine.

I then let the matter rest until I finished harvesting. We then got ready for threshing, but I made the mistake of keeping my old separator, which had seen seven years' service and had done good service with horse power and portable gasoline engine, which only just had sufficient power to run it. I found my new engine had power to run a much larger machine, and was hard on the old machine, which gave me lots of trouble. However, I did considerable threshing and ran along as late as December 28th, 1911. All through the season, the engine gave us very little trouble, and if I had got a larger machine I could have done a great deal better.

I purchased an 8-furrow Cockshutt gang plow in 1911, but only got in three days' plowing, when it was too wet to thresh.

Last spring I was in the hopes of doing great things with my engine, but as it was a continual succession of one rain following another, I did not do anything to blow about. I did considerable plowing, but there were so many wet spots, and so much short turning, that it was impossible to work to advantage.

During June we had some dry weather, and I did some breaking, but I took one job where I got into a soft hole, and it took a week of hard work to get out, as I broke (cut clean through) eight 3/4-inch bolts, which hold the differential

Continued on page 79

The **POWER** behind the **PROFITS**

of Successful Farming Today!



The BIG FOUR is the power behind BIG PROFITS

It furnishes you with the *surplus* power you often need to do a great amount of work in a very short space of time, thus taking every possible advantage of weather conditions.

With the BIG FOUR you can plow, pack, drill and drag at one operation, (ordinarily the work of 30 horses and 10 men) putting your crops in *right behind the plows*, when the soil is soft and moist, aiding earlier germination.

You can work the BIG FOUR day and night, if necessary, for it can work 24 hours a day just as well as 8 or 10, making your seeding a matter of *hours* instead of *weeks*. Mr. E. F. Luebke,

Valley County, Mont., broke, packed and drilled 100 acres in three days and nights with his BIG FOUR "30."

The BIG FOUR enables you to plow *deeper*, utilizing the rich sub-soil, now seldom touched, to increase your yields. Mr. J. A. McMillan, of Crookston, Minn., who farms with a BIG FOUR, says his wheat threshed out *more than double* per acre than his neighbors, who farm exactly the same kind of land with horses.

With the BIG FOUR you can harvest your grain 100 acres or more per day, before half your crop is lost through delay. You can furnish your own power for threshing, at a cost of 2 to 3 cents a bushel. You can run *all* the machinery on your farm at *least* cost.

The Big Four "30"

The BIG FOUR "30" is the most economical, most efficient, most reliable farm power in use today. No farmer who has ever used the BIG FOUR or seen it work, will have any other. You are not buying an experiment when you buy the BIG FOUR—its long record of results has *established* its efficiency and economy!

The BIG FOUR was the *first* successful farm tractor. It is still the first. It is the first to utilize the efficient, continuous power stream of the four-cylinder principle. Its mammoth 96-inch drive wheels give it tractive power far greater than any other tractor of equal weight and rating, and enable it to work in soft ground better than any other tractor.

SOLD ON APPROVAL!

It must make good on *your* farm, on your test, before you pay out a cent. It has a self-steering device, possessed by no other tractor, that steers in plowing better than can be done by hand—saving one man's wages and costing you not one penny extra. "Thursday, my boy plowed 52½ acres with the BIG FOUR"—Ole H. Bang, Oslo, Minn.

SOLD ON APPROVAL
Steers Self, Saves One Man.
First Four-Cylinder Tractor.
Uses Kerosene, Gasoline, Etc.
Most Power at Lowest Cost.

The BIG FOUR uses kerosene, gasoline, benzine, naphtha, distillate, or alcohol with unequalled efficiency and economy.

The horse no longer has a place in economical farming. His limitations, his uncertainty, his enormous cost compared to his productivity, have finally and for all time rung down the curtain on his usefulness to the scientific farmer of today.

The BIG FOUR "30" is the one biggest unit—the one greatest asset—in modern farm economics—the very cornerstone of the foundation of greater farm profits.

The BIG FOUR "30" is the *first step* for any farmer to take who has determined to abandon expensive, uncertain, hit-and-miss methods and to get the benefits of the increased yields, better quality of crops, and larger profits his land is capable of producing.

Don't make any mistake. *Investigate* the BIG FOUR "30." It will stand the test. Write us NOW for the BIG FOUR BOOK.

Emerson-Brantingham Implement Co., The Largest Line of Farm Machinery in the World.
(INCORPORATED) **Rockford, Illinois, U.S.A.**

TUDHOPE, ANDERSON & CO., LTD.,
1195 Princess Street, Winnipeg, Man., Canadian Sales Agents.

Regina, Sask. Saskatoon, Sask. Calgary, Alta. Edmonton, Alta. Lethbridge, Alta. Brandon, Man. Yorkton, Sask. Swift Current, Sask.

COURSE IN GAS ENGINEERING

CONDUCTED BY D. O. BARRETT

This course consists of a series of practical talks on the theory and practice of the gas, gasoline and oil engine. They will be simple, illustrated when necessary, and of such a nature that the gas engine owner may easily adapt them to his daily engine work.

LESSON XXVI

Suggestions and Hints

It should be remembered that whenever the engine has to stop on account of the plows, discs, drills, binders or whatever machinery the engine is hauling, there is the same loss to the owner that there would be if the trouble were with the engine. It is here that foresight and planning may make a difference of a good many days in the course of the year's work. Always remember that it makes no difference in the loss of time and money, whether the outfit stops on account of a \$50 sod crusher, or a \$5,000 engine. All this machinery behind the engine must be kept in running condition or the engine will fail to do the work it is expected to do.

At the present time most farm machinery is made to be pulled by horses and is none too strong. More than this, it is usually set up for the first time at some im-

plement house by unskilled help. For these reasons, before coupling up the engine, it is best to go over every nut and bolt and make sure that they are tight and will stay tight. It is impossible to keep single nuts tight of themselves. There should be lock nuts or cotter keys to keep them tight. A lost bolt may cause several hours delay. Several lost bolts may strain some casting so that it will break and cause a much longer delay. Therefore, there are two things that must be looked to before the greatest work can be accomplished by the engine. First: to forestall all possible delays by making everything perfectly tight. Second: to be prepared to make quick repairs in case of breakage.

Before starting out on a season's work, the possibility of repairing any breakages in this machinery should be provided for. This equipment should include: a blacksmith's forge and outfit for making quick repairs and for straightening and sharpening plowshares; a good supply of band or strap iron; assorted-sized nuts and machine bolts; a good kit of machinist's tools; a drill press or a ratchet drill and an "old man"; a breast drill for drilling small holes; a full set of machinists' drills, taps and dies.

The owner of a gas traction engine who planning on hiring someone to run his engine for him, should consider several things, besides the necessity that the man he hires knows all about gas engines. Every town is full of young fellows who have never had any experience in handling heavy duty machinery but who have acquired a fair knowledge about gas engines. Where their knowledge of gas engines will help them once during the season's work, their lack of knowledge about the care of heavy duty machinery will show itself a hundred times.

If possible, the owner should select a man whom he knows will instinctively take an interest in keeping the engine in first-class shape. He should have had experience in handling heavy duty machinery and some farm experience. If he knows gas engines and has had traction engine experience, so much the better. But the thing to remember is that

while it is perfectly possible for any intelligent man to learn gas engines, it seems to be next to impossible for a naturally careless man to ever learn how to take care of any piece of machinery that is put in his charge. It is perfectly possible to teach a careful and intelligent man to handle a tractor reasonably well in a season. For these reasons the owner should always try to pick the right man in preference to the knowledge of gas engines. If he can get both in one man, he should take pains to keep him for they are scarce.

To rebabbit bearings; first be sure that there are anchor holes in the bottoms of the boxes to hold the babbitt in place. Place the shaft in position and in perfect alignment. Be sure that there is no moisture at all in the boxing. Heat the boxing if the weather is cold and also to be sure that there is no water or moisture in the pores of the box. Make cardboard discs to fit around the shaft at each end of the bearing. Fill all around bearing with putty or fire clay so that when the molten metal is poured into the box, it cannot run out. Leave one large hole to pour in the metal. Have several holes on top for the air to come out as the space between the shaft and the box is filled with metal. For high-speed bearings use only the best babbitt. Heat it hot. Clean off the scum from the surface of the babbitt. This scum is formed by the oxidation of the tin and antimony in the babbitt. Never allow any of this scum to get into the bearing. Pour babbitt into the boxing steadily and as fast as possible. Never stop pouring until the box is full. When the babbitt is hardened, take the box apart and scrape the bearing to fit the shaft.

In the case of replacing a drift key that is used to hold a gear or pinion, it should be remembered that it is only the sides of the key that they have any value in holding the gear to the shaft. If the key fits tight on top and is driven into place with considerable force, it will often split the gear or hub. Few realize the force that is exerted from the slight taper of a key, and much damage is done as a result. Always leave at least one-thirty-second of an inch clearance on the top of the key. The key should always fit very tight on the sides and the gear always

fairly tight on the shaft. If it is loose, it will soon shear off the key.

Do not prime the cylinders until all the oil has been washed down. Pour a little cylinder oil with the gasoline. The gasoline will remain just as explosive and there will be no danger of running the pistons without any oil when the motor starts. Remember that in a motor having an eight-inch stroke, running at 600 revolutions per minute, that each piston will travel 800 feet in one minute. If you have washed all the oil from the pistons and cylinder walls, it may be necessary for the piston to travel several hundred feet before it receives any lubrication. This is rather hard on piston rings, pistons and cylinders.

Do not use a dusty pail for handling cylinder oil. Keep the oil barrels corked so that the dust cannot sift in. Cup grease and hard oil are often carried in an open pail on the plows or on the back of the engine. As this is a very dirty place, the grease is soon in a condition to be more useful for grinding valves than to be put in hard worked bearings as a lubricant. Be sure that you keep your hard oil in dust-tight buckets.

The operator should always realize that it requires better footing for the engine to travel fast than at slow speed. When an old engineer gets into soft places, he slows the speed of his engine down until the wheels are just barely moving around. If the engine does not move ahead, he pulls out his clutch and throws some timber under the wheels before trying to go ahead. A beginner will do just the opposite. The more the drive wheel slip, the wider he opens the throttle.

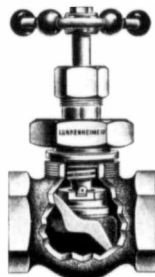

LUNKENHEIMER REGRINDING VALVES

NO EXTRA parts are required to repair these valves when the seating faces become worn. Just a few minutes spent in regrinding makes them as tight as when new. To regrind them, or to replace any broken or worn parts with new ones, it is not necessary to remove the valves from their connecting pipes.

Lunkenheim Regrinding Valves can be packed under pressure when wide open, and the areas throughout the bodies are largely in excess of the nominal diameter of the connecting pipes.

They are made in medium and extra heavy patterns, for working pressures up to 200 and 300 pounds per square inch respectively, and in sizes ranging from 1/2 to 4 inches.

Your local dealer can furnish them; if not, write us.

3-14 Write for Catalogue J

THE LUNKENHEIMER CO.

Largest Manufacturers of High Grade Engineering Specialties in the World

General Offices and Works: CINCINNATI, OHIO, U.S.A.
 New York Chicago
 64-68 Fulton St. 186 N. Dearborn St.
 Boston London, S.E.
 138 High St. 35 Great Dover St.

Mention this magazine when writing advertisers.

WELL DRILLING

**GUS PECH
FOUNDRY AND
MANUFACTURING
COMPANY**

Manufacturers of the
Celebrated

**MONITOR WELL
AUGERS AND
DRILLS**

Write for prices
and Illustrated
Catalogue.

125 MARSH, IOWA
U.S.A.
Branch House:
REGINA, SASK.

Mention this magazine when writing advertisers.

The Foundation of Profitable Farming

DEPENDABLE POWER

AT LOWEST COST

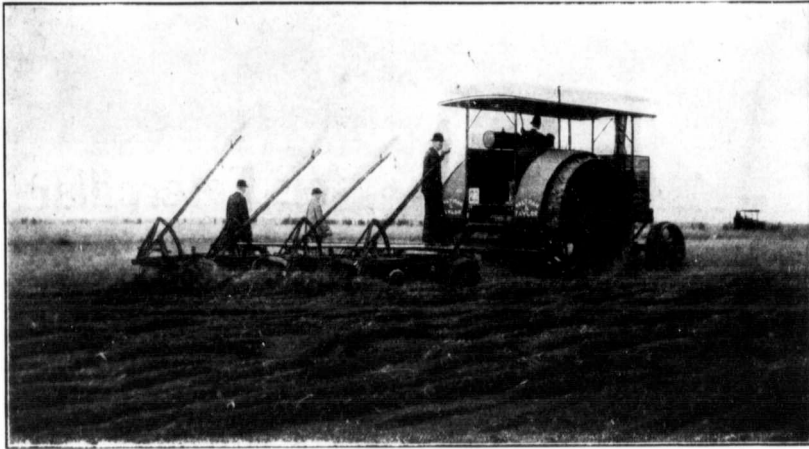

Here's The Tractor Which Backs Up Every One of our Broad Claims of Superiority

In this era of scientific farming the general purpose farm tractor is fast supplanting the horse. Feed is high, horses expensive, hired help scarce, so that the farmer is being driven to seek more economical farm power. The successful farmer of today is equipping his farm with a reliable, durable power plant, one which places under the control of one man, the power of many horses and men—does practically any work on the farm formerly done by horse and man, and does it quicker, cheaper and better. **Hundreds of wise farmers have displayed sound, keen judgment in the solution of this problem. They disposed of the greater part of their horses and paved the way to bigger profits by purchasing**

AULTMAN - TAYLOR 30 - 60 GAS TRACTORS

They not only did their work quicker, cheaper and better, but they increased the yield by getting their crops in early and in taking advantage of favorable weather and soil conditions.

Before you place your order for a tractor, we invite you to investigate the AULTMAN-TAYLOR 30-60. Look well into its design and construction, as well as its past record. Go deep in this investigation. Learn why it is the talk of the farm power world. Why it has backed up every one of our broad claims—that it is the most economical, most reliable and durable, most simply and accessibly constructed, requiring the least skill to operate and less annoyance and upkeep cost than any other tractor on the market today.

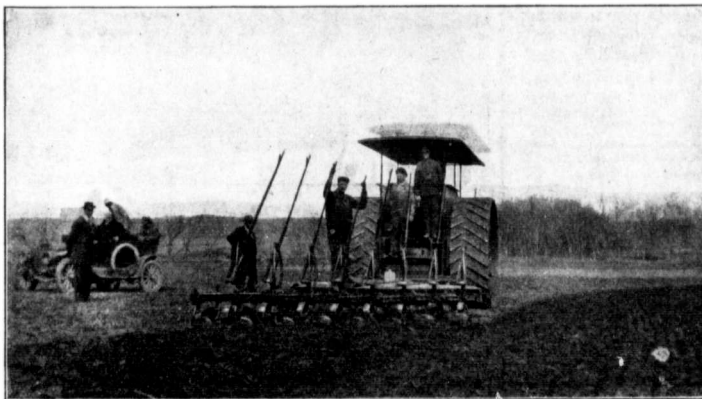

WRITE TODAY for descriptive literature of this superior tractor—it's free. Now is your time to investigate this tractor proposition. Get in communication with us. **WE CAN SAVE YOU MONEY.**

The Aultman & Taylor Machinery Co.

MANSFIELD, OHIO. Lock Box No. 64.

BRANCHES: Minneapolis, Minn., U.S.A. Calgary, Alta. Regina, Sask., Canada

Questions and Answers For Gas Engine Operators

This is a department for gas engine operators similar to that which we have so successfully carried on for the past few years for those interested in steam. We invite your questions and will give them our best attention. Just tell us your troubles or ask us about any point upon which you desire information. We have secured the services of a competent expert who can handle gas engine queries intelligently and to the complete satisfaction of all concerned.

Ques. What is the duty of a lubricant?

Ans. The duty of a lubricant is to reduce friction; the lubricant accomplishes this by keeping the parts separate, being pressed out into a thin film on which the moving parts rub, thus preventing direct contact.

Ques. Why is direct contact objectionable?

Ans. Because metal surfaces, although they appear smooth to the eye and to the touch, are made up of minute irregularities which are visible when magnified.

Ques. How do these irregularities act?

Ans. When two metal surfaces are brought into contact, these minute irregularities interlock, retard the motion, and tear off the projecting particles.

Ques. What term is applied to the tearing off of small metal particles?

Ans. Wear; when a bearing is allowed to run dry, the wear will often result in the piling up of such loose particles, which, due to pressure and the resulting heat, are again welded together, forming irregular humps on one of the surfaces, which cut grooves into the adjoining surface. This is usually termed cutting or grooving.

Ques. What is the final effect of cutting?

Ans. If not remedied in time, it will result in freezing, that is, the adhesion of the surfaces to each other.

Ques. What are the essential requirements of a lubricant?

Ans. 1, body, 2, fluidity or viscosity, 3, freedom from gum-

ming, 4, absence of acid, 5, stability under temperature changes, and 6, freedom from foreign matter.

Ques. What is meant by "body" of a lubricant?

Ans. The body indicates a certain consistency of substance, that prevents it being entirely squeezed out from the rubbing surfaces. The body of a lubricant should be such as to prevent a too rapid running off, depending on the working pressure.

Ques. What is understood by fluidity?

Ans. Fluidity of a lubricant refers to a certain lack of cohesion between the different particles, which reduces the fluid friction. Fluidity, so far as it does not oppose body, is a desirable quality. Excessive fluidity allows the lubricant to run off too quickly, thus causing waste.

Ques. What is stability of a lubricant?

Ans. A lubricant is said to be stable when it retains its good qualities under temperature changes.

Lubricants should retain their good qualities even when used under high temperature, as in the cylinder of an engine, or when used under low temperature, as in exposed bearings.

The lubricant should not evaporate or be decomposed by the degree of heat to which it will be exposed under working conditions. It must retain its normal body and fluidity as much as possible, and must not congeal by cold.

Ques. How are lubricants classified?

Ans. As solid or liquid.

Ques. How are they classified with respect to composition?

Ans. As animal, vegetable, or mineral.

Ques. Name the solid lubricants?

Ans. Graphite, soapstone, and the various lubricating greases.

Ques. What is graphite?

Ans. Graphite is one form of carbon; it has an iron grey color and metallic luster. Graphite is soft and unctuous to the touch, and is known also as black lead and plumbago.

Ques. In what two forms are graphite used?

Ans. In the crystalline or flake, and the powdered form. Graphite is also known as black

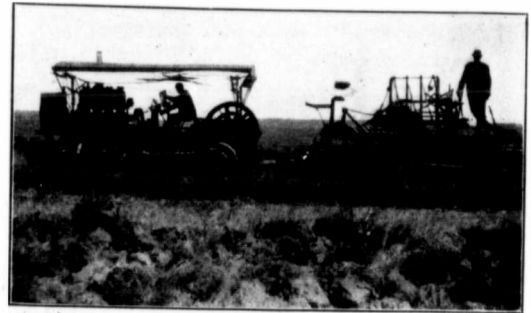

Holt Caterpillar Tractor

The all purpose Farming and Freighting Tractor

Most practical because it works on wet ground and won't mire down. The long bearing surface of the Caterpillar track on the ground does it. The Caterpillar is compact with a low center of gravity: it is simple and accessible and you know what that means in the field. The Caterpillar is especially good for seeding because it doesn't pack the ground and because it can be used much earlier in the spring than a wheel engine on account of wet and soft land. If you wish more information your name on a coupon will bring it.

Canadian Holt Co. Ltd.

609 Eighth Avenue West

Calgary, Alberta

Name _____
Address _____

C.T. & F.
2-1-18

You saw this advertisement in this magazine. Don't forget to say so when writing.

**GILSON ENGINE
"GOES LIKE SIXTY"**

Anybody can operate the simple "GOES LIKE SIXTY" Engine. Ready for work the moment you get it. Built strong and solid to last a lifetime. Will give long, unflinching satisfaction. Gas, gasoline or kerosene can be used for fuel. Gilson quality gives full value for your money—dependable service, great durability, highest economy and perfect satisfaction; freedom from trouble, delays and expense. Every engine ABSOLUTELY GUARANTEED. You can try this engine on your own farm before settling for it. You take no chances. The "GOES LIKE SIXTY" Line has an engine for every purpose. All styles and sizes from 1 to 40 h. p. Write for catalogue
GILSON MANUFACTURING CO., LIMITED
York Street, QUELPH, ONT.

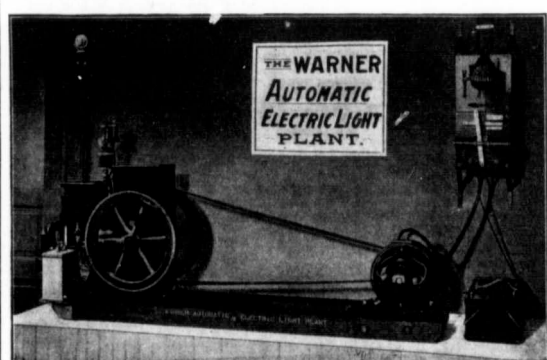

AUTOMATIC ELECTRIC LIGHT PLANTS

For Farmer, Rancher, Storekeeper, Hotel, Moving Picture Theatre, Village, or Town. All absolutely automatic, the engine starting and stopping itself whenever necessary. No electrical expert needed. Plenty of light and power for Pump, Grinder, Cream Separator, Electric Stove, Toaster, Heater, Fan, Sewing Machine, etc. We can install the plant, wire your buildings, and furnish all fixtures, etc. No danger, no bother, they run themselves. All sizes up to towns of 1000 population.

AUTOMATIC ELECTRIC OUTFITS

For Automobiles, Tractors, Plowing Outfits, etc. No cost for operating. Powerful searchlights for plowing. Plenty of light for all machinery.

Ask for Catalogues and Prices.

WESTERN MOTOR COMPANY

305 Carlton Street

WINNIPEG

You saw this advertisement in this magazine. Don't forget to say so when writing.

lead and plumbago. Black lead usually refers to inferior grades of graphite.

Ques. Is graphite used in its pure state only?

Ans. It is sometimes mixed with oil or grease, and in such combination makes an excellent lubricant.

Ques. Can graphite be used in the cylinder of an engine?

Ans. Yes; on account of its ability to withstand high temperatures, it makes a desirable lubricant for the cylinder. It fills up the pores of the metal, and forms a smooth surface, reducing friction, and tending to prevent leakage past the piston.

Ques. How is graphite applied to the surface of a cylinder?

Ans. In various ways; some prefer to mix it with oil in the form of a paste, and open the cylinder to apply the paste to the cylinder walls. It may also be introduced through the spark plug opening at intervals, or through a regular cup made for the purpose.

Graphite should be used moderately, as it is a conductor of electricity, and if the spark plugs become fouled with it, trouble will result.

Ques. How is soapstone used?

Ans. Soapstone is used in the form of a powder or mixed with oil or grease. It should, however, be used sparingly, especially when mixed with oil, as it may clog the oil grooves of a bearing.

Ques. What may be said about the use of grease?

Ans. The various lubricating greases are well adapted for heavy pressures under slow speeds. They are generally fed to the bearing under pressure of a spring compression grease cup or a screw compression cup. The lubricating qualities are often improved by mixing with graphite.

Ques. Where is grease especially desirable?

Ans. On the crank shaft bearings of a two-cycle engine, as on account of its consistency it will not run out, hence, it will make the bearings tighter against leakage of crank case compression.

Ques. What are liquid lubricants?

Ans. The various grades of oils.

Ques. How are oils classified as to reference to body?

Ans. As light or heavy.

Ques. How are oils classified as to their origin?

Ans. As animal, vegetable, or mineral.

FLOUR CITY TRACTORS

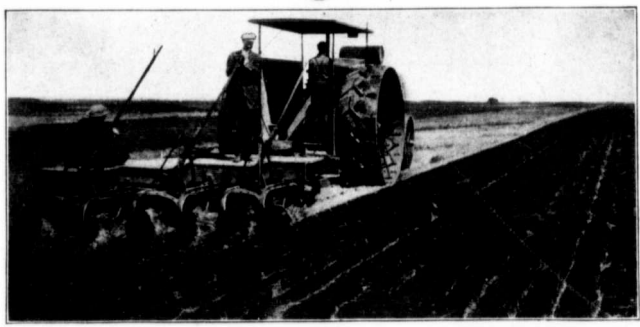

A WORD TO THE FARMER

The "FLOUR CITY" tractor has often been referred to as the Pioneer that blazed the way in tractor development. To a certain extent this is true. Being one of the first in the field, it could not start where others left off, or profit by their experiences. It fought its way single-handed and alone and stood the blunt of all the vicissitudes incident to the development of special machinery for a new field.

It is built on honor, sold on merit, and stands for **QUALITY, EFFICIENCY and SERVICE**. Its success is due to its development in conscientious hands. It carried off four gold medals in as many years in the Winnipeg Contests, in both Gasoline and Kerosene classes. No other tractor on the market has equalled its record; no other tractor has earned the honors bestowed on the "FLOUR CITY."

Our 1913 Model with its complete change of color; with its dust shields over the drivers; with its new Cooling System, carries with it added efficiency and a pleasing outline. Built in three sizes, viz., 20, 30 and 40 H.P.

If interested, write us for our 1913 Catalog No. 19.

828 44th Avenue North

KINNARD HAINES CO. MINNEAPOLIS MINN.

There was a funeral in one of the small farmhouses in the neighborhood of Cape Cod, and the friends of the deceased were gathering in the tiny parlor when there entered the room a typical New England female of the kind that mingles curiosity with sympathy. As she glanced around the darkened room, she said to the bereaved woman.

"Where did you get that new eight-day clock?"

"We ain't got no new eight-day clock," was the reply.

"You ain't? What's that in the corner there?"

"That's the deceased. We stood him on end to make room for the mourners."

A creased hat and a cigarette never made a real man.

\$83,978,739 of Business was held in force by The Great-West Life Assurance Company at December 31st, 1912. This was a **GAIN** of \$16,009,307 for the year.

Other impressive facts from the 1912 record were:

APPLICATIONS RECEIVED, 1912	\$26,156,166
INCREASE for the year	7,136,813
SURPLUS EARNINGS, 1912	573,460
INCREASE for the year	131,386
Net Death Claims, 1912	328,615
DECREASE for the year	6,661
Assets December 31st, 1912	12,261,981
Average gross rate of interest earned	7.95%

All indicating the wide demand for Great-West Policies—and the sound reasons therefor.

The Great-West Life Assurance Company
Head Office - WINNIPEG

CASE

THE BEST WAY TO GET RELIABLE POWER FOR PLOWING
IS TO BUY A CASE STEAM ENGINE OR A CASE GAS TRACTOR

CASE

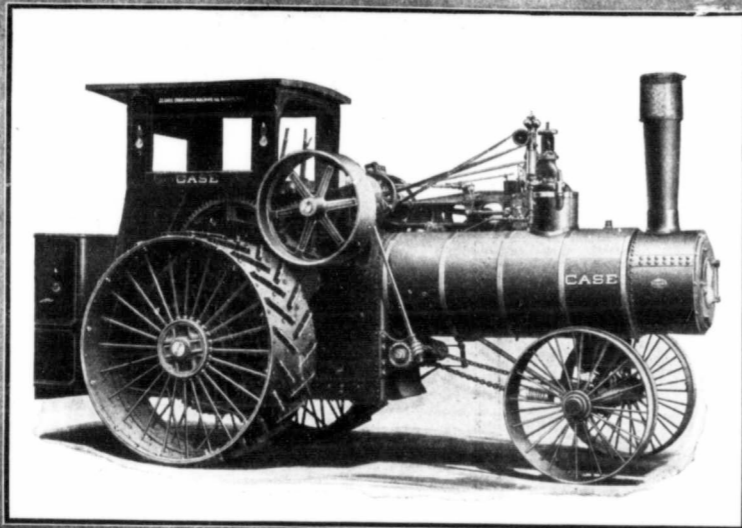

LISTEN HERE, YOU MEN WHO ARE INTERESTED IN ECONOMICAL STEAM PLOWING. Fuel is Money—and unless you have "money to burn" you don't want an Engine that sends your profits up in smoke at the rate of twenty to fifty pounds more coal to an acre than is necessary.

Get Fuel-Wise. Get out your Fuel Bill. Find out just what your Fuel is costing you—then figure out what a difference a saving of twenty to fifty pounds of coal per acre will make in your expenses.

If you are going to buy a new Engine, make the man that would sell it to you, face fairly and squarely the question of Fuel Consumption. Back him up against the wall and make him tell you how much coal it takes to plow an acre with his Engine—and make him prove it.

Case Steam Plowing Engines have repeatedly demonstrated their ability to plow on a Fuel Consumption of less than One Hundred pounds per acre! Any 110 H. P. Engine that takes more than One Hundred pounds is a money-waster—and costs more to operate than it should. We are talking FACTS now—with the figures of the Winnipeg Motor Contests to back us. NINETY-NINE AND TWO-TENTHS pounds of coal to an acre in 1910 and NINETY-NINE AND THREE-TENTHS pounds to an acre in 1912 for the big 110 H. P. Case Plowing Engine is a record in Low Fuel Consumption never approached by any other Steam-Plowing Outfit. No Engines entering the Winnipeg Contest in the past three years have used under 120 pounds to an acre except the Case.

No matter what you pay, you can't buy another Plowing Engine so Economical to Operate, so Well-Built and Powerful as the Case. Every part and feature of its construction has been Time-Tried and Time-Proven.

*You are interested in Economical Power Plowing.
 Don't fail to write for a Case Steam Plowing Catalog*

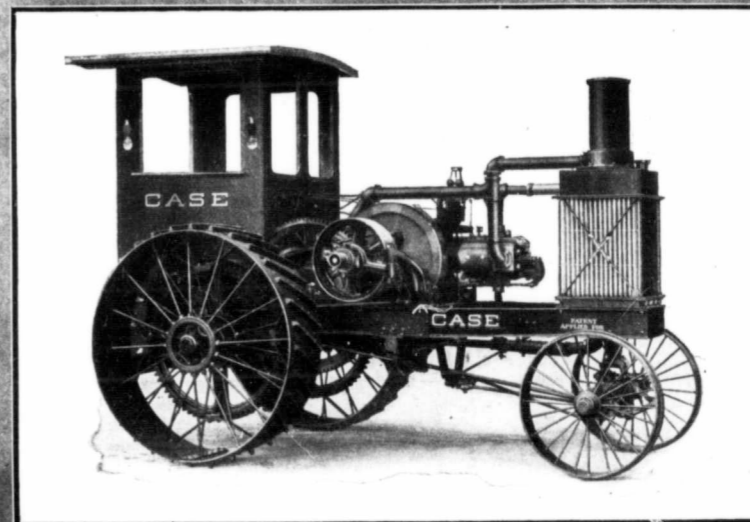

If it's a Gasoline Plowing Engine you want, the Case 40 H. P. Gas Tractor will suit you to a "T." The more you know about a Gas Tractor, the better the Case will suit you—and the easier it will be for us to sell you one.

It's the people who "know" that are buying the Case—the critical fellows who have learned by experience what a Gas Tractor must be and do to return the best profits to its owner.

The Case 40 Gas Tractor represents the absolute limit of up-to-the-minute Gasoline Engine Development. You'll find in it all the very latest ideas for minimizing Expense of Operation and increasing Power and Efficiency. It will do more work on less fuel than any other Gas Tractor you can buy—and it's as easily controlled as an Automobile.

There isn't a chance in the world of your being disappointed when you buy a Case 40 Gas Tractor. We have made your satisfaction a positive certainty by doing all of the experimenting on the Case Gas Tractor at our own expense before we offer it for sale. We sell ourselves every Case Gas Tractor before we sell it to you and you may believe that when our Laboratories and Expert Engineers who examine and test every part and every piece of material and every finished machine are satisfied to put their O. K. on a machine before shipping, you can't find anything to criticise.

Visit our nearest Branch House and have the many improvements in the development and application of Power as embodied in the Case 40 Gas Tractor explained to you in person or if you can't do that, write us at once for Literature that will make plain to you why the Case 40 Gas Tractor is the most Economical to Operate the most Easily Handled and the most Efficient Gas Tractor for Plowing and General Power Service.

J.I. CASE THRESHING MACHINE COMPANY

INCORPORATED

741-791 STATE STREET RACINE, WIS. U.S.A.

CANADIAN BRANCHES, TORONTO, WINNIPEG, SASKATOON, REGINA & CALGARY

CASE

CASE

MEASURING FARMS FOR IMPROVEMENT

How Manitoba farms are getting into the long britches of better management as a result of the Government's Good Farming Competitions

DID you ever go into a tailor-shop and get measured for a new suit of clothes? The tailor took a tape, you remember, and went over you from head to foot, lengthwise and crosswise, calf, waist and chest, seven-come-eleven! He took a flat piece of chalk, perhaps, and you could feel him making marks around your neck and down your back. Perhaps it tickled you and perhaps it didn't; but whether it did or not, you got a new suit with creased trousers that made you positively ashamed of the old one.

Now, if the tailor had said to you and the other customers present, "Line up, gentlemen. The man who looks best in his new clothes is going to receive a fine prize from me"—if the tailor had said that, there would have been a great straightening of the coat-collars and pulling down of sleeves and parting of hair and so forth. And the result, aside from the prizes, would have been an increased pride in your personal appearance and a determination to have your next suit with the coat-tail a little longer or shorter as the case might be.

It is something like that with the Good-Farming Competitions which are a part of the program provided by the Provincial Department of Agriculture with the difference that every man is his own tailor, the Government judges doing the measuring afterward. There is, perhaps, no branch of the Government extension work that creates a greater improvement in farm life than the Good-Farming Competitions. The interest in these friendly contests have been growing rapidly throughout the province and already a great deal of good has been accomplished; during the summer of 1911, the latest year for which complete returns are available, the interest manifested was greater than in any previous year. The liberal supplementary prizes offered by the railways helped to accelerate the popularity of the contests not a little.

The Sweepstakes prize-winners for 1911 were: (1st) W. H. English, Harding, Manitoba; (2nd)

John Ching, Morden, Manitoba; (3rd) John Pierce, Miami, Manitoba.

The Good-Farming Competitions are conducted through the various Agricultural societies of the province, the cash prizes gen-

erally being provided by them and the Department of Agriculture allowing an increased grant to such of the societies as conduct these competitions. The judging of the farms is usually left to the staff of the Agricultural College, assisted by a few prominent and successful farmers. E. Ward Jones, B.S.A., has had charge of this work and the assistance of others of the college staff has been of great value.



Farm of John Ching, Morden, Man. Winner of 2nd prize (sweepstakes), Good Farming Competition, '11

erally being provided by them and the Department of Agriculture allowing an increased grant to such of the societies as conduct these competitions. The judging of the farms is usually left to the staff of the Agricultural College, assisted by a few prominent and successful farmers. E. Ward Jones, B.S.A., has had charge of this work and the assistance of others of the college staff has been of great value.

The judging is based upon a score-card prepared by the Field Husbandry Department of the Agricultural College. The total number of points possible is one thousand, perfect scores being allotted as follows:

- General Appearance 50 Points
- Cultivation—
 - Including tillage in general system of crop rotation, condition of summer fallow...200 Points

cluded the impression which the farm creates on approach and a general plan of the property. The methods employed in plowing, harrowing, soil packing, etc. are considered under the head of Cultivation as well as the system of crop rotation and summer fallow. Close attention is paid to the latter two phases, especially the presence or absence of a good system of rotation. In examining the condition of crop under the heading of Farm Crops special attention is given to vigor of growth, freedom from weeds, other kinds of grain which may have got mixed in and the extent to which the crops are true to their variety. Where special fields are grown for seed it is considered an advantage by the judges. Noxious weeds are looked for with a fine-tooth

the continued fertility of the land hinges upon this requisite.

It is an unfortunate fact that too many Manitoba farmers are negligent of their farm machinery and this is an item well included in the Good-Farming score that machinery must be well housed, and in good condition for efficient use. The advisability of some provision being made for repair work is also emphasized and the Good-Farming judges report a great many farms throughout the province which are now equipped with small forges and repair shops.

The farmstead is one feature of the measuring of the Good-Farming Competitions which might easily result in a certain amount of unfairness to some contestants were the score not subdivided very carefully. But in reaching a decision an effort is made to avoid handicapping the man of limited means; small, well adapted and sufficient house and barns are given practically as high a mark as the more expensive and pretentious places. A special point is made of the suitability of the buildings and the convenience of their situation in regard to water supply, drainage, location and sanitary improvements. The condition of the yard is taken into consideration, the location and construction of wells and the judicious planting or arrangement of trees and hedges as protection for buildings, stock, etc. In short, stress is laid upon the homelike and practical conditions of the farm surroundings.

Several of the judges who have been engaged in making Good-Farming Competition awards for a number of years note a remarkable change in certain districts as a direct result. Particularly is this noticeable where friendly but keen rivalry has sprung up between groups of farmers. A steady improvement in appearance has marked some of the farms and it is a significant fact that the prizes do not go to the same men every year by any means.

Occasionally amusing situations arise because of the rivalry



Cattle barns on farm of W. H. English, Harding, Man. Winner of 1st prize in Good-Farms Competition, 1911

- Farm Crops—
 - Condition, purity, variety 350 Points
- Live Stock—
 - Breeding, variety, comparative numbers, feeding, care and management150 Points
- Machinery—
 - Condition, care, management

comb, as the saying goes, and the seed selection from year to year is enquired into.

The necessity of a sufficient supply of live stock is another point which is not overlooked as

Five Reasons and One More

Why You Should Use Cockshutt Implements

The five implements described below, because of their value to you in increasing your crops, and their mechanical superiority, are very good reasons why you should use Cockshutt Implements. The other reason is this: the name of Cockshutt is a guarantee to you of quality—it stands for all that is best in design, workmanship and material. Your neighbors for generations have used Cockshutt Implements because they knew they could not buy better. The reputation we have built up through this long and satisfactory service is your safest guide in buying farm implements.

Don't take any chances—be sure, by insisting on having implements which bear the name of Cockshutt

Cockshutt Drills

INCREASE CROPS

One of the chief reasons why you should use Cockshutt Drills is that they will increase your crops. Cockshutt Drills increase crops because they seed more accurately and thoroughly than other drills. The heavy I beam sill which extends the entire length of the drill absolutely prevents sagging. This means that the feed cups will sow accurately and regularly as there is no cramping or binding of any of the working parts. The preventing of sagging also insures

the seed being planted at an even depth. The furrows opened by the discs have wide bottoms. This gives the seed an opportunity to spread out so that the roots are not crowded, but are enabled to draw plant food from a large amount of soil. At the same time the seed is properly covered. The staggered set of the discs prevents trash from dragging and interfering with their work.

Cockshutt Drills are making better crops everywhere, why not let them do that for you?

Kemp Manure Spreaders

INCREASE CROPS

Every farmer must return plant food to the soil if he expects to continue taking crops from it. Barnyard manure is the best fertilizer that can be used, but it must be spread evenly. Fork spreading gets too much in one place and not enough in another. Besides, it wastes time and labor.

The Kemp spreads manure evenly and in any desired quantity. It makes fertile fields, better crops, more prosperous farmers. As, for instance, one top dressing of manure applied with a Kemp Spreader, immediately after seeding, will result in an increase of from five to six bushels per acre. These are good reasons why it will pay you to use a Kemp Spreader.

**See
The Cockshutt
Dealer**

COCKSHUTT PLOW COMPANY Limited

Western Branches: Winnipeg Regina Calgary Saskatoon
Distributing Points: Red Deer Lethbridge Edmonton Brandon Portage la Prairie

Cockshutt Pulverizers and Sub-soil Packers

INCREASE CROPS

The Cockshutt Combined Pulverizer and Sub-soil Packer has all the features of the regular packer, with the additional advantage of the V-shaped rims, which act as sub-soil packers. The small channels formed by the V-shaped rims prevent blowing of the soil, and they also retain rain. Where a heavy crop of stubble or weeds has been plowed under a layer is formed separating the surface soil from the moist sub-soil. The V-shaped rims press the top plowing through this layer and bring it in contact with the moist sub-soil, so that the plant roots are able to secure the necessary water. The result is better crops.

Cockshutt Pulverizers are also made with regular wheels. Use one of these machines and give your crop a chance to increase.

Wonder Grain Cleaners

INCREASE CROPS

Like produces like, good seed means larger crops of better grain. Grain is paid for according to its grade. And here is the point to remember: It costs no more to raise the best grade than it does a second or third grade. Why sow wild oats when a crop of wheat is wanted? Why sow weak, undersized seed when an A1 crop is wanted?

The Wonder Grain Cleaner is absolutely necessary to increase crops.

The New Cockshutt Potato Planters

INCREASE CROPS

Because they permit a large acreage of potatoes to be planted quickly and economically, these planters are valuable crop-increasing machines. Make it a point to see one of these new Cockshutt planters. They have exclusive features that make for the best kind of work. Made in one and two row styles with or without fertilizer attachments.

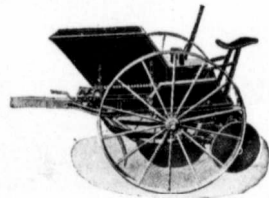
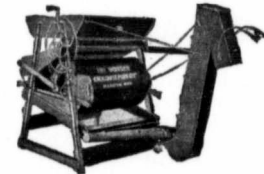
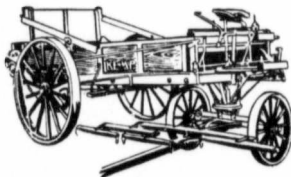
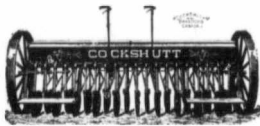

THIRTY-EIGHT YEARS' EXPERIENCE

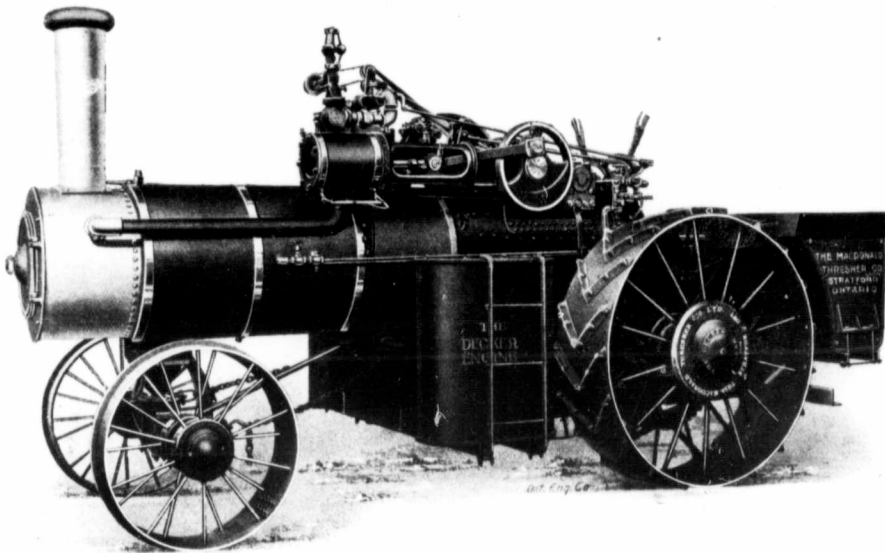

Manufacturing the famous "Decker" line of Threshing Machinery. Engines in sizes as follows:

18, 20, 22 and 25 h.p.

Boilers command 175 lbs. steam pressure. "Decker" Valve Gear, superior to all devices used for the purpose, heavy gear suitable for hard work. Plowing engines a specialty.

"Decker" Separators

made in the following sizes:
24-46, 28-50, 32-54 and 36-60.

Well adapted for gas power, being easy to drive. A marvel of simplicity; efficient in separation and convenient to handle. Wind Stackers, Feeders, Baggers and a full line of thresher supplies.

Write for Catalogue.

THE MACDONALD THRESHER CO. Limited

Western Branch: Winnipeg, Man.

Box 1296

**Head Office and Factory:
Stratford, Ontario, Canada.**

You saw this advertisement in this magazine. Don't forget to say so when writing.

between neighbors, in connection with the judging. A few years ago Farmer A. and Farmer B., whose properties adjoined, were both entered in the Good-Farming Competition for their district and each was hopeful of winning first place. Both men were good farmers with pride in their homes and for a number of years each had tried to outdo the other in the matter of improvements.

When the time came for judging the various entries in the competition, it so happened that the gentlemen of the score-card and pencil examined Farmer A's place about five o'clock in the afternoon. It so happened also that the judges were English with the English habit of enjoying a cup of tea in the afternoon, a fact which Mrs. Farmer A. was quick to appreciate, being English herself. We have it on good authority that that was a great cup of tea and that the cake and bread-and-butter and so on were perfect scores also, aside altogether from the fact that tramping about a Manitoba farm in the Manitoba fresh air will create the famous Manitoba appetite every time. Farmer A. won the prize that year!

Next year, strangely enough, the whole situation was reversed. Both farms were again entered

and both farmers were again keen rivals; but this time it so happened that the gentlemen of the score-card and pencil examined Farmer B's place about five o'clock in the afternoon. The judges were the same judges with the same English habit of enjoying afternoon tea. Mrs. Farmer B. was not asleep but up and doing and again we have it on good authority that the cup of tea was great and that the accompaniments were very acceptable to the aforesaid Manitoba appetite. Farmer B. won the prize that year!

Of course, it just happened that way; for each farmer won on his merits. But every time Mrs. A. and Mrs. B. take tea together their tongues do more than taste and they have their suspicions. Of course, it just happened that way; but can you blame them? No, of course not. Very well, then!

Seriously, though, the judges in these competitions are eminently fair in arriving at their conclusions. The better to record impressions accurately, the cards in every case are filled out on the spot as the inspection of the farm proceeds. Memory, even a good memory, is not allowed to play any part in the scoring and the farmer has the satisfaction of

knowing that his card is completed without any outside influences affecting the score to which his farm is entitled upon its merits.

At the close of the competition copies of the score-cards are sent to each competitor in order that he may know the weak points of his farm. It will be seen at once that the instructive value of these competitions is great and that practical improvement in every phase of farm management is the direct result.

Before entering for one of these Good-Farming Competitions a farmer is required only to be a resident within the radius prescribed by the Agricultural Society conducting the competition and to accompany his application with the nominal fee required by the society.

The judges are at the disposal of each Agricultural Society upon request and are sent to carefully examine the specified farms, generally just before the crop matures.

Already these competitions have clearly demonstrated that life on the farm in this province may be made just as enjoyable as in any other of the older provinces and when one notes the progress that is being made one must hope that the Agricultural Societies

throughout the province will take hold of the opportunity held forth by the Good-Farming Competitions and with the assistance of the Government and the Railways do their best to encourage this very important movement towards farm improvement, towards individual self respect and prosperity.



Don't linger by the way,
Do it now!
You'll lose if you delay,
Do it now!
If other fellows wait,
Or postpone until it's late,
You hit up a faster gait—
Do it now!

—Frank Farington,
in New York Sun.

He who knows himself great accepts the truth in reverent silence, but he who only believes himself great has embraced a noisy faith.



To be honest is to set all knaves against thee.—Tennyson.



Think well! Do-well will follow thought.—Tennyson.



What the tongue is, I suppose the man is.—Dickens.

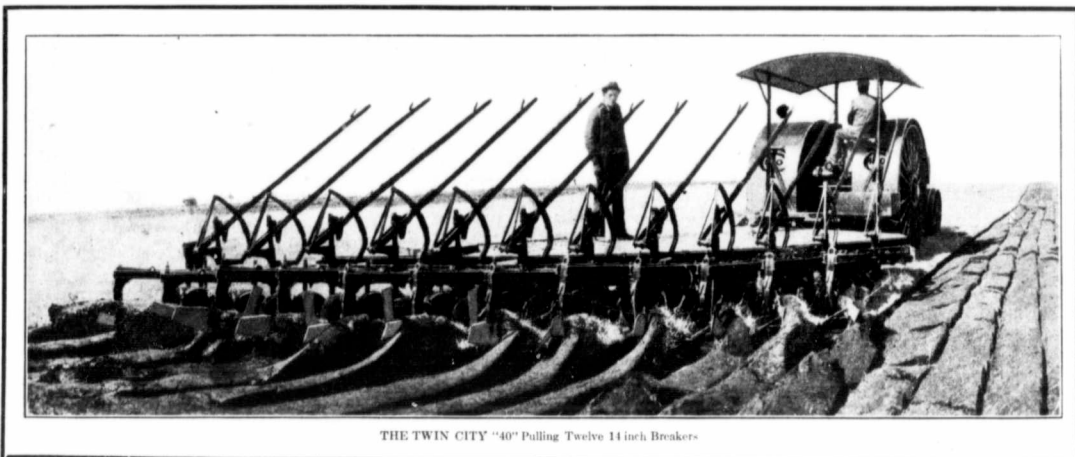

THE TWIN CITY "40" Pulling Twelve 14 inch Breakers

There is something about this Big Work that is impressive—It conveys the feeling of the tremendous power it requires. Think of what it means to break 12 furrows of sod at one time. Figure out how many horses it would take to do such work, then consider that the Twin City Tractor can do it night and day without resting.

You can't put your finger upon a single weak spot in this machine. Consider the work it does then look at the machine itself you can see the power of the modern locomotive in its design. That steel plate girder frame embodies maximum strength with that excellence of design which eliminates all surplus metal and makes this the lightest tractor per horsepower on the market.

Twin City Tractors

Built in Two Sizes

25 and 40 Tractive Horsepower

WRITE FOR TWO BOOKLETS, 7H AND 9H.

Minneapolis Steel & Machinery Company of Canada Ltd.
Regina, Saskatchewan

Specifications:

Twin City "40"

4 cylinders—vertical—bore 7 1/4 in.—stroke 9 in.—cast separately with solid heads.

5 bearing crank shaft 3 3/4 inches diameter.

Flyball governor—force feed oiling—Enclosed water cooling—5 inch live rear axle.

40 tractive h.p.—65 belt h.p.

Twin City "25"

4 cylinders—parallel—horizontal—6 in. x 8 in. cast in pairs—crank shaft parallel with rear axle—3 in. diameter—cooling, oiling, governing s as on Twin City "40." 4 inch live rear axle—25 tractive h.p.—45 h.p. at belt wheel.

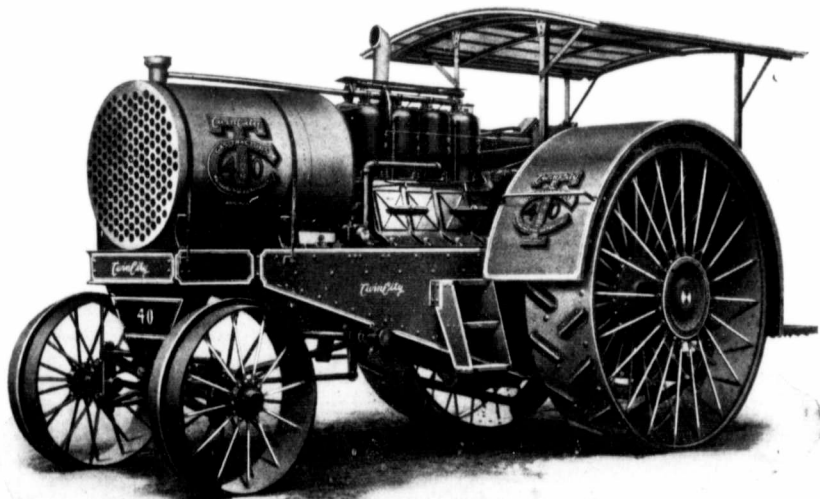

THE TWIN CITY "40"

You saw this advertisement in this magazine. Don't forget to say so when writing.

FOR GOOD FARMING IN SASKATCHEWAN

Alfalfa Trials on the University Farm in 1912

DURING recent years the Provincial Department of Agriculture at Regina, and the Dominion Department, through its system of Experimental Farms, have been doing some work with a view to finding a biennial or perennial legume that is suited to the climatic conditions of the West. At the time of the organization of the University, the results of this work seemed to point to alfalfa as being the hardiest, heaviest yielding and in general, the most to be desired forage crop.

With this information in mind, the Field Husbandry Department of the College of Agriculture immediately took steps to lay out a series of experiments that it was hoped would give more light on the culture of crop under the climatic and soil conditions of Central Saskatchewan. A considerable amount of work is now under way, and during the past year our first records of yield were obtained. These are submitted below, followed by such comments as seem

desirable to a thorough appreciation of the work reported. The season was a very favorable one for alfalfa—the average temperature was high, the rainfall above the average except during the first three weeks of June, and the growing season was long.

Strain	Average of	tons	lbs.
Grimm's	4 strains	3	1678½
Sand Lucerne	3 strains	3	1167
Turkestan	2 strains	3	318
Provence	1 strain	4	381
Common	Average of 2 strains	3	886
	Average of 1 strain	3	743
	Average of 1 strain	3	706
	Average of 2 strains	3	007

We have found Grimm's, Sand Lucerne and Turkestan in the order named, to be most suitable. The best strains of each of these yielding more than any strains under any other name except Provence. Grimm's, Sand Lucerne and Provence are "variegated"—that is, they have white as well as purple blossoms, indicating that they contain some blood of the Siberian alfalfa, Medicago Falcata, Provence killed out very considerably, but in

spite of that gave a very large yield. The yields given are for alfalfa in its third year—1912. Several strains of Siberian alfalfas have also been tested. They are very hardy, inclined to be woody, have rather a bitter flavor, give a large first crop, but very little after growth. We do not consider them satisfactory for general use, but hope to use them to advantage in breeding hardiness into some of our other varieties.

Inoculation—Grimm's	T.	lbs.
None	1	1369
Soil	1	1800
Pure culture	2	800

These plots were sown in 1911

seems that this method of inoculation is more worthy of consideration than we have thought in the past.

Rates of Seeding (Grimm's)	T.	lbs.
10 lbs. per acre	1	1440
15 lbs. per acre	1	1480
20 lbs. per acre	1	1920
25 lbs. per acre	1	1800
30 lbs. per acre	1	1800

These plots were sown in 1911 on land fallowed the preceding year. The figures are for 1912 yields. They go to show that somewhat heavier seeding than has generally been advocated, is desirable. This conclusion is not necessarily a correct one for two

given to each. The drill remained set at the same figure while seeding all plots, the difference in amount of seed used being due to the closing of half the spouts in one case and two-thirds of them in another.

Cultivation of Alfalfa (Dakota Turkestan)	T.	lbs.
Double disced and harrowed in early spring	1	665
Double harrowed in early spring	1	530
No cultivation	1	485

The alfalfa in the plots that were cultivated was later than that on the uncultivated plots and as a result the first cutting (all were cut at the same time) was less. The second cutting more than made up the deficiency, as the figures show. These plots were drilled in 6 inches apart, 18 lbs. per acre, in 1911 on land fallowed in 1910.

Both the two-year-old and three-year-old fields were seeded in the same way, at the same rate, inoculated similarly, sown on soil prepared the same way. The three-year-old plants were on slightly heavier soil. Figures are for 1912:

Three year old vs. Two year old Alfalfa in 1912	3 Years Old	2 Years Old	T lbs.
Grimm's Mont.	4	10	11800
Turkestan	3	196	11560
	318	Avg of 2 Strains	510

It is quite possible that if 1911 had been a dry year the results might have been different, particularly so if 1912 had also been dry. It is expected the yield of old alfalfa fields will be measured by the amount of precipitation during the fall and winter and early summer previous to cutting, and that after the second and third year the yields will be lighter. In dry years the yields from old fields is sure to be very light.

It was observed that where the crop was cut late the previous year the plants were considerably later and very much shorter at the time of first cutting than were those on areas that had attained a fair second growth in the fall of the year before.

John Braken.

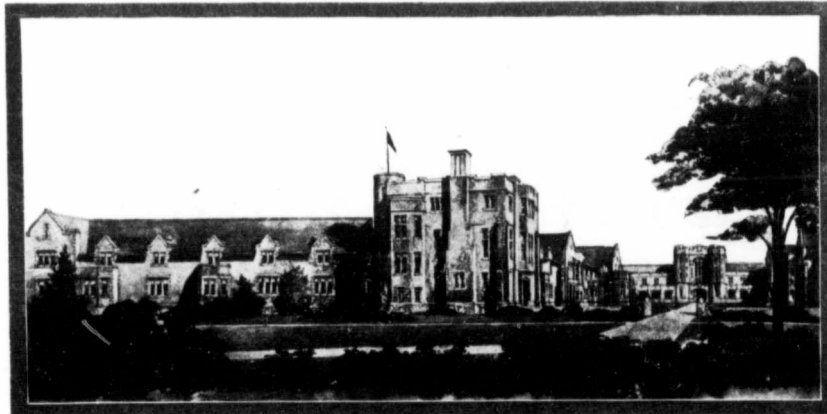

Students' Quarters, Saskatchewan University, Saskatoon

and the yields are for 1912. The soil used for inoculation was taken from a two-year-old alfalfa field which had been inoculated with soil from Indian Head. The culture was secured from a commercial concern in New Jersey. The results are significant, but it

should be remembered that soil from an alfalfa field of greater age might have given better results. These plots provided a most striking demonstration during the whole summer of the value of inoculation. No single visitor when asked which was the better plot, failed to point out the one treated with nitroculture and the untreated plot was always recognized to be the poorest. If the culture can be transported without danger to the bacteria contained therein, it

reasons: first, the year was particularly favorable as regards rainfall (notwithstanding the drought of June); and second, the surplus of moisture stored in the soil from the fallow of the second year previous, a supply which would be lessened very little, if any, by the growth of the young plants the year before. This is but one year's results, and these were secured under rather abnormal conditions. We still believe 10 to 16 lbs. of good seed to be sufficient if the seed is good and the soil in condition.

Methods of Seeding (Dakota Turkestan)	T.	lbs.
Broadcast 18 lbs. per acre	1	560
Drilled 6 inches apart, 18 lbs. per acre	1	345
Drilled 12 inches apart, 9 lbs. per acre	1	935
Drilled 18 inches apart, 6 lbs. per acre	1	1425

These were also sown in 1911 on land fallowed the previous year. Yields are for 1912. All plots were double disced and harrowed early in the spring. Exactly the same cultivation was

The RUMELY Power-Farming Way Leads to Better Profits

The Rumely way means work done better, work done cheaper and work done with less of the old-time drudgery and hard labor. With your own Baler, Sheller, Husker-Shredder, Feed Mill or Ensilage Cutter, you can do your work just when you want it done. You can keep your tractor or stationary engine busy a greater part of the time. You can open the way to better profits.

The Rumely Automatic Baler

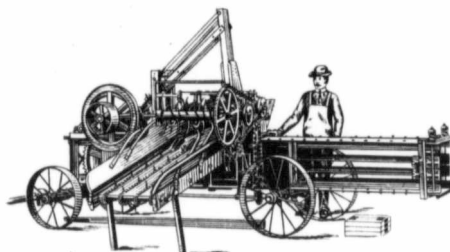

The Rumely Automatic Hay Baler

Here's a baler that's plenty large enough for custom baling, yet it is a paying investment for the individual farm. With it you can bale hay, straw, alfalfa—cut or whole fodder of any sort. This is the only baler with a self-feed, that cuts out the labor of one man and means quicker feeding and neater bales. Capacity under ordinary conditions, about 35 tons a day. There's also a Junior Baler for the smaller farm. Write for our Baler catalog, Number 245.

The Rumely-Watts Corn Sheller

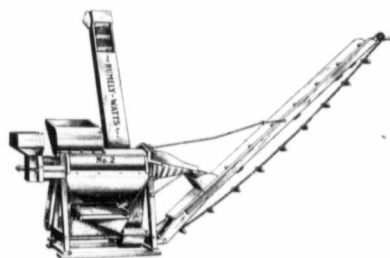

Rumely-Watts Corn Sheller

With a Rumely-Watts Sheller on your farm, you needn't worry about whether the custom sheller is coming around on time. You shell your corn when you want to, just when the market is right. The Rumely-Watts gets all the corn and doesn't chew up the cobs. It comes in two sizes—a single and double cylinder sheller. The smaller size has a capacity of 75 to 150 bushels per hour; the larger from 175 to 350 bushels. You'll be interested in our new catalog about these machines. Ask for Number 351.

The Rumely Feed Mill

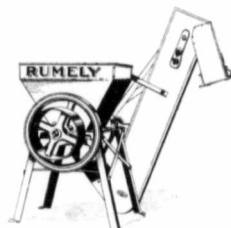

Rumely Feed Mill

This is a new member of the Rumely Line, but of the same high standard as the machines we've been building for 60 years. Built in four sizes, for grinding oats, corn, wheat, barley, etc. A cob crusher provides for grinding ear corn as well as shelled. Break pins prevent breakage of important parts. The power required ranges from 3 to 15 horsepower, according to the size of the mill. A fully descriptive catalog of the Rumely Feed Mill can be had for the asking. Ask for Number 432.

The Rumely Line includes stationary, portable and traction engines run by steam, gasoline or kerosene power. A size for every power need and a price for every pocket-book. Rumely-Olds engines in sizes from 1½ to 65 horsepower. OilTurn engines range in size from 1½ to 30 horsepower. In tractors, there's the GasPull in a 15-tractive, 30-brake and a 30-tractive, 60-brake size—the OilPull in the same sizes.

Drop a postal today, stating the catalog you wish us to send—the OilPull, Number 353; the GasPull, Number 352; the Rumely-Olds Engines, Number 344, or the OilTurn catalog.

Ask us the name of your nearest dealer.

RUMELY PRODUCTS COMPANY

(INCORPORATED)

Power-Farming Machinery

La Porte - - - - - Indiana, U.S.A.

Canadian Branches: Brandon, Man. Estevan, Sask. Toronto, Ont. Calgary, Alta. Regina, Sask. Vancouver, B.C. Edmonton, Alta. Saskatoon, Sask. Yorkton, Sask. Winnipeg, Man.



GOOD ROADS FOR MANITOBA

BY A. C. EMMETT

The writer of these articles (which will be continued from month to month throughout the year) has had a wide and severely practical experience and is specially engaged on the "Good Roads" movement.

THE rapidity with which the Goods Roads movement is growing in Manitoba is evidence that the value of well constructed highways as an aid to the development of the country districts has been realized by all classes of the community.

A recent report, from the office of the Highways Commissioners, shows that a sum of over \$500,000 has been voted for the improvement of highways in the municipal areas within a radius of twenty miles of Winnipeg, whilst the same activity is being shown in the more outlying districts.

In the municipality of Wallace a by-law is to be submitted authorizing the issue of bonds to the value of \$160,000 to create a fund for the construction of permanent improved highways.

Manitoba has long been behind the sister Provinces of Alberta and Saskatchewan in securing a fair share of the immigrants that are flocking into Canada from the United States. The situation has not been due to the lack of good farm lands in the province, but to a lack of suitable roads to provide proper intercommunication between the farms and the towns. The Million for Manitoba League is a step in the right direction toward overcoming the trouble in regard to settlement, and it is interesting to note that the League is using every effort to boost the Good Roads cause, thereby showing that it recognizes the positive necessity for providing inducements of the right sort which will enable the Province to secure a million population.

At no point in the province has so much criticism been levelled by Americans, as the stretch of road between the international boundary and Winnipeg. That there was room for such criticism will be granted by those who are familiar with this highway. For two or three days after every rain-storm, the road is practically impassable and the impression in the minds of those who may be attempting a journey to Winnipeg over this route is about as poor an advertisement as the Province of Manitoba could have. Fortunately there appears to be every reason to believe that this state of affairs will be remedied in the near future. A good start has been made by the construction of the bitulithic road through the municipality of Saint Vital and the scheme instituted by the municipality of Ritchot, which

will provide for the carrying out of road improvements as far south as Union Point, 25 miles from Winnipeg. Once this work

will come over this route in far greater numbers and will spread the news of the many opportunities available for settlers in the

the hauling of the farm produce to the city market and Winnipeg, will save hundreds of dollars which are spent at the present time in the payment of heavy freight charges on produce shipped in from the south.

The municipality of Rosser, which recently passed a good roads by-law calling for the construction of main highways in all directions throughout the district, will find that the raise in property value, caused by these improvements, will raise the assessable value of the entire districts served by these highways, to such an extent that the cost of their construction will be a mere bagatelle in comparison with the advantages secured. Dairy farming is a great feature in this locality and the difficulty of conveying the produce over the roads in wet weather has always been a stumbling block to its more rapid development.

Signs for Meridian Road

Permission has been granted by the telephone commissioner for the use of the telephone poles for sign-posting the Meridian Road between Winnipeg and Emerson. This work will be carried out as soon as spring opens up and will be done by the executive officers of the Canadian division of the highway.

When all the signs have been painted on the poles it will undoubtedly stimulate interest in the improvement of the roads between Winnipeg and Emerson, and the work already planned by the municipalities of St. Vital and Ritchot will act as a spur to the remaining municipalities between Morris and Emerson.

All the work in connection with the Meridian Road is of a voluntary nature and many prominent men are putting their shoulder to the wheel, on the different divisions of the road, and using every endeavor to make this highway one of the leading traffic routes. On the Canadian division the officers are: C. F. Roland, Industrial Commissioner, president; W. F. Tallman, Street Commissioner for the City of Winnipeg, vice-president; A. C. Emmett, Winnipeg Automobile Club, secretary; Mayor Berry of St. Boniface and A. McGillivray, Provincial Highways Commissioner, also act as members of the Canadian executive.

The first steps toward opening this highway between Winnipeg and the Gulf of Mexico, were

is completed, the other municipalities between Union Point and the boundary line at Emerson will undoubtedly take up the work, with the result that tourists

Red River valley and the districts surrounding Winnipeg.

Market gardening will also grow by leaps and bounds with the provision of good roads for

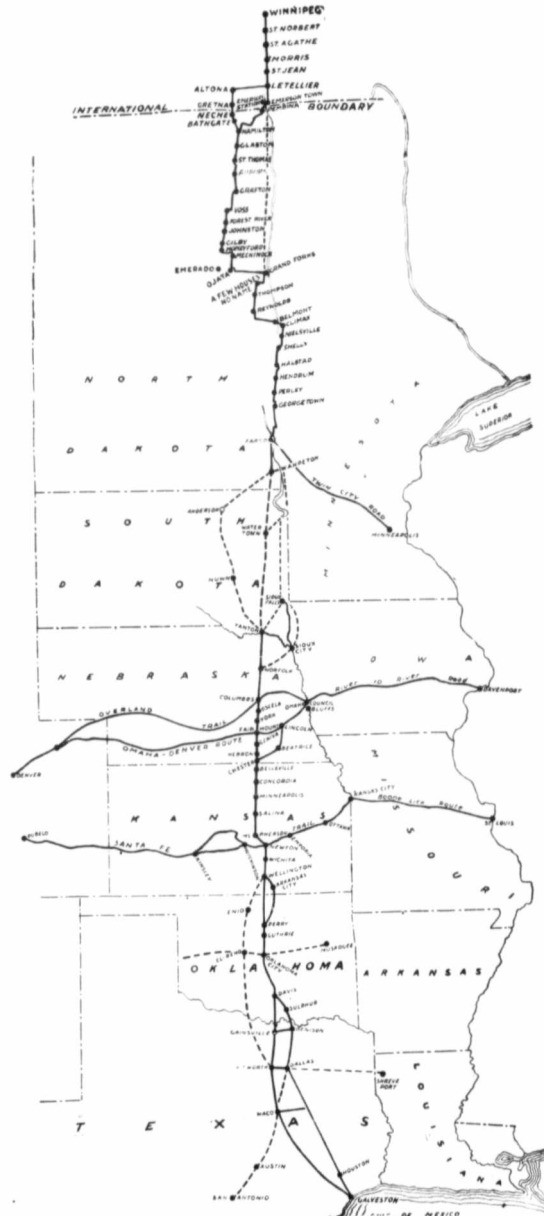

The Meridian Road from Winnipeg to the Gulf of Mexico.

"The Great Minneapolis Line"

Gas Tractors

Big General Catalog Now Ready

Steam Tractors

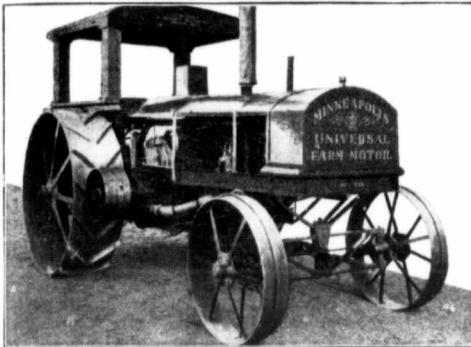

20-H.P. 2-Cylinder (Opposed)
"The Biggest Little Tractor Built"

We are waiting
your address

Every Progressive
Farmer and
Thresherman should
have one.

Do not delay
But write today

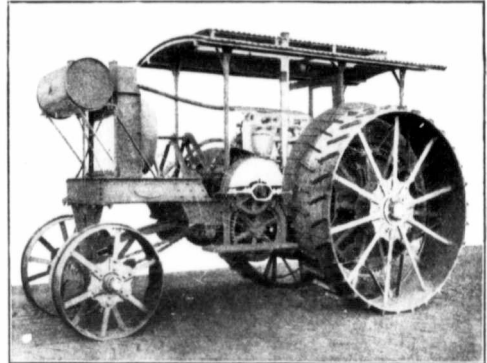

25-H.P. 4-Cylinder (Vertical)—Efficient and Reliable

Expensive tinkering
and loss of time is the
penalty that falls
upon the purchaser of
a cheap or inferior
Tractor

It pays to buy
the best

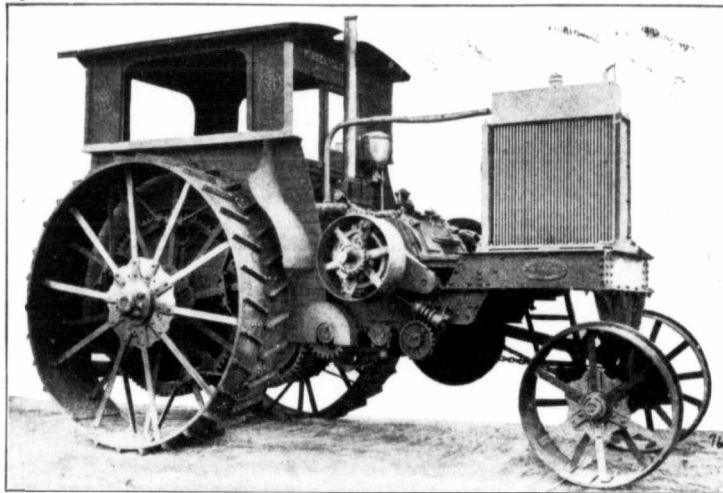

40 H.P. 4-Cylinder (Horizontal)—The Farm Motor Superb

We welcome
comparisons and ask
you to consider the
real MERITS of our
machinery before
making your decision

Our customers are
pleased

ALWAYS - - - "THE MINNEAPOLIS" - - - ALWAYS

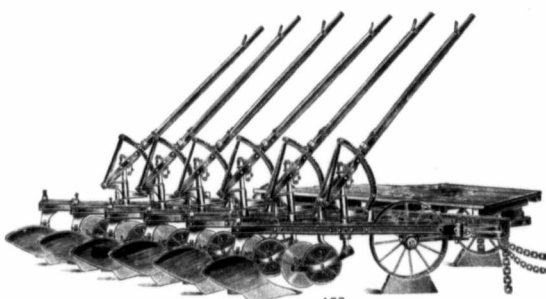

Well-made—Easily handled—Does good work

THRESHING MACHINERY

C
O
U
R
T
E
S
S
Y

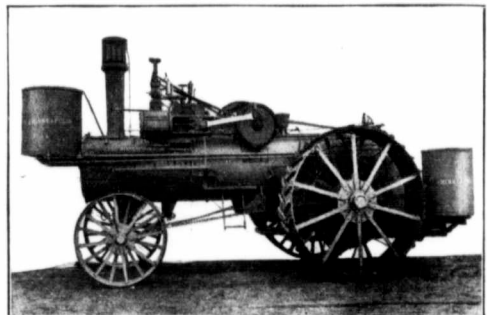

Strong—Safe—Simple

ENGINE GANG PLOWS

THE MINNEAPOLIS THRESHING MACHINE CO.

West Minneapolis (Hopkins P.O.), Minnesota, U.S.A.

REGINA

WINNIPEG

CALGARY

EDMONTON

You saw this advertisement in this magazine. Don't forget to say so when writing.

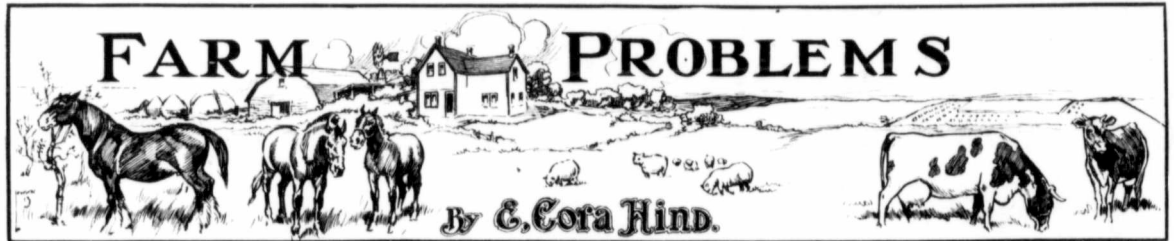

At the conclusion of the article in the January number, it was suggested that the slogan for 1913 should be: "Smaller areas, better cultivation and bigger yields." It seems fitting therefore, to take up first of all some methods of cultivation. As was said on the start, the object of these discussions on farm problems is, primarily, to help the new comer, and therefore the best methods of cultivating new prairie land will be considered first. It is the firm conviction of the writer that the most profitable farm will ultimately be found to not exceed 320 acres, or 480 acres at the extreme outside. A man who has homesteaded 160 acres, or the man who has purchased 320 acres, and wishes to secure the best possible seed bed, needs to consider first of all in what section of the Canadian West his land lies. If it is on the bare open prairie, with the tough sod so characteristic of the country forming the great central and southern plains of the three western provinces, there is little doubt that the old time practice of breaking and backsetting is the best. The breaking should be done as shallow as possible and it should be done in June, and certainly, to get the best results, not after the third week in July, in fact, it would be always safer and better to put the time limit of breaking, especially on the open prairie, at the 10th of July.

Now, the next thing to consider is, what shall the farmer do his breaking with? Breaking on farms of the sizes described must be done with either oxen or horses, and for the new comer with limited experience and also limited capital, oxen are decidedly the best. They are cheaper to buy, cheaper and easier to feed, very much less liable to disease than horses, and if they are properly broken and trained, will make almost as good time as any horses which the new beginner, with limited capital, would be in a position to purchase. A very good plan is for a man to purchase two yoke of oxen, one of them thoroughly well broken and trained to drive from the plough handles, and the other yoke younger and less thoroughly broken, and therefore less expensive. The best results are secured by ploughing with three oxen, hitched to a walking plough, and

the illustration published herewith gives a splendid idea of how the work should be done, how the oxen should be harnessed, and the kind of work which they will produce. By having the two yoke, it will be possible to work them turn about and so have one ox always resting and fresh. In this way, considerably more ground

can be covered in a day. In the early days of Red River farming, breaking and backsetting were all that was considered necessary, but there has been considerable advance on these methods, and it is now realized that to get the best results from breaking, the land should be packed immediately after being broken. This

is more particularly essential in the drier districts of the three provinces. The packing brings the sod into closer touch with the moisture in the soil below and facilitates rotting.

and then it should be backset. To the old timer, the term of backsetting is as familiar as ploughing, but for the benefit of the possible new comer who is not familiar with Western terms, to backset is to plough an additional furrow 2 to 4 inches in the same direction as the breaking has been done. The sod at breaking should be

only 2 inches thick if possible, and should not exceed 3 inches. The thinner the breaking can be done, the better the seed bed. When the backsetting has been done, drag harrow it well in the direction it was ploughed and then cross harrow it. If the district is a very dry one, it will do no harm to pack the land a second time just at the close of the season. Land treated in this way, even with a very light rainfall, can be worked until it has almost the appearance of a summer fallow. Having been allowed to lie all winter, as soon as the snow is off in the spring, and the surface is reasonably dry, the harrow should be put on again and it should be harrowed thoroughly once or twice, and three times if possible, before the seed is put in.

If a man cannot afford a regular packer, a cheap and fairly successful roller can be made of concrete, at a very small expense, about \$20 in fact. This answers very well indeed for the packing down of the sod in breaking, but should not be used in the fall, as it packs the land too smooth on the surface, and leaves it liable to crack, and moreover prevents it absorbing any late rains. A seed bed prepared in this way and allowed to mellow by the frost during one whole winter before it is seeded, will give results that would be surprising to the man who has attempted to grow a crop on spring breaking. The growing of crops on spring breaking is sometimes a necessity, but only very dire necessity excuses a man for adopting this slipshod form of cultivation. Where spring breaking is done, and immediately planted, flax is the usual crop, and it is not too extreme a statement to make that if a man breaks fifty acres in the spring, seeds half of it to flax and backsets and cultivates the other half not seeding it until the following spring, he will have no difficulty in tracing the line of demarcation between the two seed beds for five years at least.

Scrub Land

All of the foregoing is intended to apply directly to open prairie sod. In the more Northern sections of the three provinces, where there is considerable scrub, and where very much of the sod is thinner and not so tough as it is in the open, a different method of cultivation is meeting with very great success. This is to

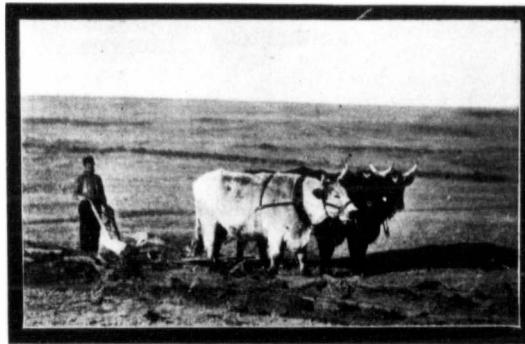

Making the seed bed with oxen



The packer should follow the breaking plow

Have a Packer

The man who is wise enough to go in for oxen instead of horses will find that he can afford a

packer in his first year. Two yoke of very good oxen can be secured for \$400 to \$450, while only one team of very medium horses can be secured for that amount, and two teams or three horses at least would be necessary to work a 320 acre farm. A packer costs, for an 8 ft., \$66; for a 12 ft., \$97; and for a 15 ft., \$140, so that buying even

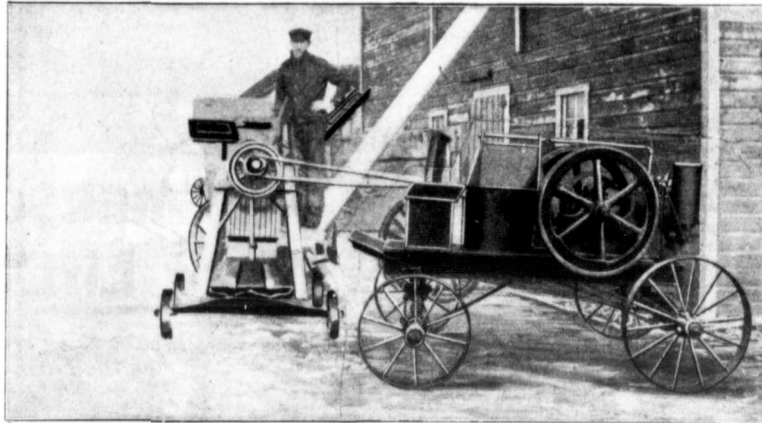

THE RUMELY OILTURN AND RUMELY-ADAMS CORN HUSKER

The Best and Cheapest Power

OilTurn motors are offered in all sizes— $1\frac{1}{2}$ to 40 horsepower. They can be had stationary, portable or mounted on skids. They are also mounted with various other Rumely power-farming machines—balers, saws, corn shellers, etc. No matter what your demand for power may be, you will find an OilTurn motor in just the size and at just the price to suit you.



*Be sure it's a Rumely
—the Only Successful
Oil-Burning Engine*

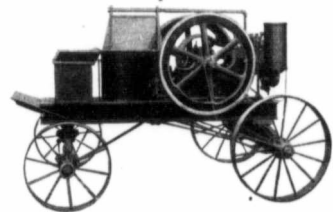

Make sure of this one thing—that the OilTurn you buy is a Rumely. The OilTurn is the little brother of the Rumely OilPull, and these engines are the only ones that burn oil successfully at all loads, all altitudes and all temperatures. They have the famous Secor-Higgins System of Combustion, fully protected by basic patents, that makes it possible to use kerosene and cheap distillates in an internal combustion engine all the time—with perfect combustion.

There's an OilTurn catalog waiting for you—chock full of interesting and valuable information. Why not send for it today?

Ask us the name of your nearest dealer.



RUMELY PRODUCTS COMPANY (Inc.)

Power-Farming Machinery

LA PORTE

INDIANA, U.S.A.

Canadian Branches:

Brandon, Man. Estevan, Sask. Toronto, Ont. Calgary, Alta. Regina, Sask.
Vancouver, B.C. Edmonton, Alta. Saskatoon, Sask. Yorkton, Sask. Winnipeg, Man.

break the land from 4 to 5 inches deep, pack it in the same way (though packing under these circumstances is not so essential as in the others) and having allowed it to lie for from four to five weeks, work it up with discs, the best plan being to use the discs first in the direction in which the breaking has been done, and then crosswise. The number of times that soil under these conditions should be disced is limited only by the time which a man has to spare from other duties. Where discing is the method followed, at the close of the season the land should be well harrowed, and furthermore should be harrowed again in the spring in the same way as if backsetting had been the method of cultivation. The only drawback which this method of cultivation has in the districts in the North, where the soil is extremely rich, is the danger of working up too deep a seed bed, thereby producing a luxuriant crop which keeps on growing when it should be ripening, and is thereby liable to damage from frost. It is this very fact which has been the reason of many frozen wheat crops in the Northern sections of all the three provinces, where very frequently the black soil is from two to three feet deep. In many of these sections, if not in all, by far the safest crop for the beginner on freshly broken land, is oats, or flax put in in the spring on ground broken the previous summer. There are different conditions in different localities, different depths and qualities of soil, but speaking particularly of the three prairie provinces, the methods described, if carefully followed out, will give the best results from virgin soil, and provide a seed bed which, with reasonable care, will be good for four, five or even six crops, before it requires to be summer fallowed. The object in preparing the new land is to stir up sufficient of the virgin soil to make a good seed bed and no more, because by so doing the land becomes warmer and more mellow than it can do if a great depth is turned up and only partially cultivated.

Summer Fallow

There are a number of methods of dealing with older land, and they vary considerably with localities. It is quite notable that farmers will tell you that they cannot summer fallow in their districts. There are probably limited areas where summer fallowing is not required more than once in four years, but a rule which has been in force at the experimental farm at Indian Head for many years will be found to apply pretty generally to those sections of the prairie provinces where the rainfall does not exceed 14 inches, namely two-thirds in crop and one-third in

fallow yearly. There is one rule as to summer fallowing which should be as the law of the Medes and Persians, that is, ploughing should be done early, and having been ploughed, the land should be kept thoroughly cultivated right up to the time that snow flies, or it should be utilized for soiling crops, which will be eaten on the ground, thereby enriching the ground, helping to pack it, and preventing the farmer from having any of his farm lying absolutely idle for twelve months.

So much has been said on mixed farming, that it is hardly safe to introduce the subject, as the farmers of the Canadian West have grown very sore over so much advice about how to do their own business, but in any section of the country, where sheep can be kept without undue danger from wolves, there is no doubt that the ideal way is to turn a small bunch of sheep in the spring on the land which is to be fallowed, and let them keep the weeds and volunteer crop thoroughly eaten down, until such time as the farmer is ready to take up the cultivation of the fallow. Then when he is ready to do this work, let him plough up a section of his fallow 5 or 6 inches, cultivate it, get it in shape, and immediately seed it to a soiling crop, say for example, wheat and oats, or oats and barley. Then, as soon as it is up any reasonable height, turn the sheep on it, and let this process be repeated all through the cultivation of the fallow. If this plan is properly worked out, the last fallow seeded will furnish pasturage for the sheep while the harvest is being got off, and as soon as the crop is in stook the sheep may be turned on to the stubble, as they will not interfere with the stooks but will clean up the stubble in a way that will surprise any man who has not run sheep in this way.

The sheep should finish the season on the piece of stubble which the farmer intends to summer fallow the next season. Managed in this way, it will be necessary to have a few acres of pasturage for the sheep, on which they may run in the period between their being taken off the fallow and the first soiling crop being ready to pasture. If sheep are not advisable, the planting of rape on the summer fallow, and turning on it either pigs or a bunch of steers, will be found equally advisable, though possibly not quite as profitable. Mr. Phin, of Moosomin, who has followed this practice of rape on summer fallow and then feeding the steers on it, for some years, has found it eminently successful and an excellent preventive of weeds on the farm. In growing rape, however, in this way, care should always be taken to not allow stock



EMERSON Foot-Lift Plow

**Makes Easy Work
on the Farm**

Makes it interesting for you and the boy. The EMERSON Foot-Lift is the easiest to handle. The operator with his foot lifts the plow out of the ground, with the team at a stand still! Or, with the famous EMERSON Foot-Lift and automatic lock-down, the pressure of the foot unlatches the plow, lowers it, and locks it into the hardest ground! It's so easy a 6-year old girl can do this!

A distinct advantage in the foot-lift is having the hands free at all times to guide the team. The lock-down device is readily adjusted so the plow will easily pass over any obstruction. This advantage can be fully appreciated in stony or stump land.

Frame. One piece heavy bar of high carbon steel. The axle of the land wheel extends all the way across at the middle; securely fastened, it makes a powerful truss frame. Moldboards, shares and landsides for the Emerson are interchangeable.

No other plow has these exclusive EMERSON features!

Perfect Work

Lightest Draft

Easiest to Handle

Longest Service

LIGHTER DRAFT—because the EMERSON is more compact, with the load carried closer to the horses, has larger wheels and is equipped with EMERSON 2,000-mile magazine axles which are 5 to 7 inches longer than other axles, preventing wobbling and play, are oil-retaining and dust-proof, and add many years to the life of the plow.

The axles, running in oil, must be light draft and durable.

You want to get the most and the best plow value.

You are naturally interested in the plow that *actually is*, and can be proved to be, *easiest* for you or your boy to handle, *lightest draft*, therefore easiest for your horses, capable of doing *perfect work*, and so made as to give you *greatest durability—longest service*.

These, briefly are the features of the EMERSON Foot-Lift Plow. You ought to know more about the many advantages the EMERSON has over other plows, for every farmer wants the best plow his money will buy.

Let Us Send You This Book

telling you why there is such a big difference—in your favor—between the EMERSON Foot-Lift Plow and others. May we mail you one now, together with—"Making Hay the Emerson Way." Send us your name now, so you'll have plenty of time to consider this important subject.

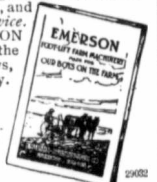

EMERSON-BRANTINGHAM IMPLEMENT CO. (Incorporated)

Rockford, Ill.

The Largest Line of Farm Machinery in the World

TUDHOPE, ANDERSON CO., 1192 Princess St., Canadian Sales Agents, WINNIPEG
Branches: Winnipeg, Sask., Brandon, Man., Calgary, Alta., Edmonton, Alta., Lethbridge, Alta., Regina, Sask., Saskatoon, Sask., Swift Current, Sask., Yorktown, Sask.

You saw this advertisement in this magazine. Don't forget to say so when writing.

Dr. Thomas' Eclectic Oil
Relieves all Pain in Man or Beast
25 Cent Bottles at all Dealers

You saw this advertisement in this magazine. Don't forget to say so when writing.

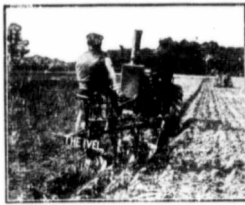

The BRITISH MADE IVEL Agricultural Motor

For all Agricultural Work
Plowing Reaping Threshing
Cultivating Mowing Chaff-cutting

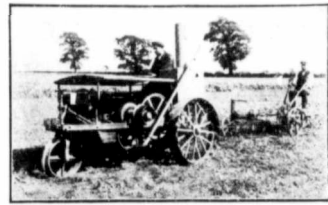

The IVEL is the PIONEER AGRICULTURAL MOTOR

Awarded 31 Gold and Silver Medals including R.A.S.E. Medal
WEIGHT OF 24 H.P. TRACTOR, 38 CWT. PRICE £367 10s. 0d.

Does not damage your Land as Nine-Ton Tractors do

IVELS are at work in all parts of the world

The IVEL runs on Paraffin, Petrol, or Alcohol

A few extracts from letters:

With regard to the work of the Ivel Agricultural Motor, there is nothing too high to be said in its praise; at the present it is plowing one of the stiffest fields in this district, and if it can do that it can do anything.

London, 5th September, 1912

You will be pleased to hear that our West Australian House (Machinery Department) report that the IVEL TRACTOR, furnished to our order No. 1773, is giving the purchaser satisfaction.

Vienna, 17th September, 1912

We beg to inform you that we are getting on very well with the one IVEL MOTOR supplied by you on the 31st May.

Great Waltham, 10th October, 1912

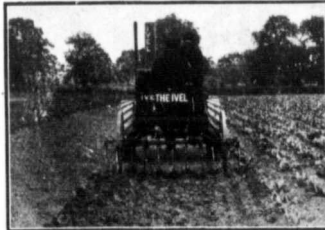

Catalogues sent Post Free on Application

IVEL Agricultural Motors Ltd. **IVEL MEADOW WORKS** Biggleswade, Beds., England



You saw this advertisement in this magazine. Don't forget to say so when writing.

to run upon it while it is wet, as wet rape is always liable to cause bloating. Where soiling crops of this kind are not made use of, summer fallow should certainly be packed in all the southern and central districts to prevent the evaporation of moisture, and finally, summer fallow which is long unplanted should be harrowed after every rain. When frost sets in there should not be one weed in sight on a fallowed field, but an even, granular blanket. It hardly needs to be stated that a man who wishes to have good returns from his land, will get all the plowing which is possible done in the fall. This is wise, not only because the frost of winter mellow the turned furrows but because our season for seeding in the spring is short, and all the time that lies between the snow going off the ground and the date of seeding can be more profitably employed in harrowing the land thoroughly and bringing it to the best possible state of cultivation.

In these methods of cultivation, nothing has been said about when and how to use manure. There has been very little fertilizing done in the Canadian West, and there seems to be a good deal of difference of opinion among farmers as to how and when to spread manure. During the past two

years, the writer has seen very good results from the spreading of manure on stubble in the fall, as early as possible after the grain has been cut, leaving it until the weeds are started, the heating of the manure seeming to facilitate this process, then plowing it in. Another method, which is claimed to do well, is to plow the land in the fall, spread the manure on the snow just before it goes in the spring and then harrow it in well. There is not much doubt that the thing which the older farms in the West are suffering from is not the method in which the manure is applied, but the fact that it is not applied at all.

Readers of these articles are reminded that the page is open to receive information and suggestions from practical farmers anywhere in the West. Another article will take up the preparation of seed grain, and the time at which various crops should be seeded.

N.B.—All that has been said as to dates of cultivation, packing, etc., applies equally to power machines, where these are used on larger farms.

When it comes to sermons, man wants but little here below, and wants that short.—H. D. Gastit.

Ontario Wind Engine & Pump Company's LINES ARE SUPREME

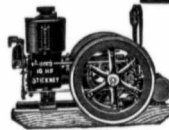

The Road To Success

Nothing succeeds like success. We succeed through the success of our Customers who succeed through the success of our lines.

Buy an O.W.E.&P. Co's. Engine, Windmill, Grinder, Pump, Saw, Water Basins, Tank, Tower, Scale, Pump Jack, Pressure Tank or Well Drill, and succeed in successfully traveling the road of success with us.

If your Dealer does not handle our lines, write the

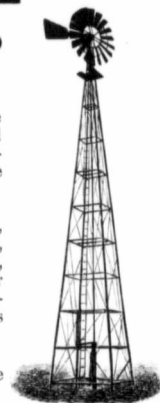

ONTARIO WIND ENGINE & PUMP COMPANY Limited, at
MONTREAL TORONTO WINNIPEG OR CALGARY

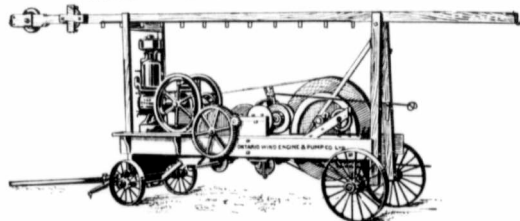

The Ancient Sport of Curling

FEBRUARY month is identified in the minds of all readers of the "Canadian Thresherman and Farmer" with three things—St. Valentine's Day, "Leap Year" privileges, and the "Roarin' Game" of Curling. We are saved the ordeal of leap-year "proposals" in 1913 and St. Valentine's Day is rapidly losing its hold save among the practical jokers of the younger race, but the curler and his time-honored art are immortal. Curling and most that is known of it in history and biography will already be common knowledge to almost every reader of this magazine.

But not everyone knows, although the question is frequently asked—where these wonderful

there and pieces fly at every stroke. But if one's mind would be at piece, then take up the hammer and wield it for a while yourself, and be assured that the easy fracture comes not by reason of a faulty stone, but by the peculiar cunning—almost instinct—of the quarryman. He can "feel" which way the rock must lie, which way to strike, and a tap suffices where your lustiest blows spring back with keen metallic ring, but leaving no impression. He seems to have a sense that can divine a flaw, and often I have seen him thrown aside a piece apparently as sound and homogeneous as the rest without deigning to test it with the hammer. Here, at the quarry, the stones are only rough-

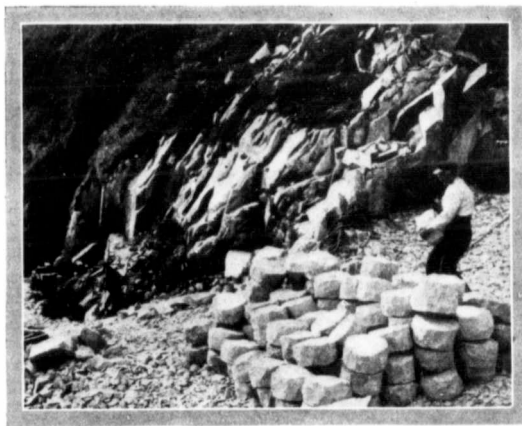

Curling Stone Quarries, Ailsa Craig, Scotland

stones come from. To a very great extent and that in the case of the very best stones employed in the game, they come from the curling-stone quarry of Ailsa Craig—a bare, rugged storm-swept rock on the West coast of Scotland. Here at the base of that mighty pile of basalt, eleven hundred feet in height from high-tide mark, this small but ancient industry has its home. Mr. Bentley Bentham, who has visited the spot and who has provided the illustration to this sketch, says:

"When watching the men at work, it is quite astonishing to see the way in which the great lumps of rock obey the dressing hammer, and might well give bad dreams to all possessors of an Ailsa stone. One might expect the finished thing to crack and chip at the first impact with its fellow, so easily is a great rough piece of rock knocked down to the required shape—a tap here, a blow

ly cut; no attempt is made to work them to their final form, and they are shipped as great bulky discs, all amply large enough to yield the perfect shape and weight. When standing in the quarry working, and seeing the large masses of granite wrested from the parent rock, one deems this work considerable, and feels a kind of sympathy for the grand old Craig thus being carved out by the subtle and resistless aid of powder; but when out at sea, looking back at Ailsa as a whole, the doings of the workers, one is glad to see, sink into insignificance, almost invisibility, and one may whole-heartedly wish them all activity, to the production of stones untold."

The coal merchant, it was mentioned, had accumulated a fortune. "No wonder," said one of the company, "look how long he's been lying in weight for it!"

Cheaper Power for Every Purpose

The WATERLOO BOY GASOLINE ENGINE will run all day without attention, furnish exactly the power you need, maintain a uniform speed and save you money every hour it works.

Use either Kerosene or Gasoline for fuel—equipped for both at no extra charge.

The recent award of Gold Medal at Budapest, Hungary, in open competition with the best engines of all countries is clinching proof that the **Waterloo Boy** leads the World in Construction, Power, Service and Durability.

Has many important exclusive features—Speed Lever works like throttle in a locomotive, oil reliable by ball governor, automatic feed regulation, open jacket, starts easy in Winter, interchangeable parts, etc.

Lowest in price because made in largest quantities, at low manufacturing cost. Guaranteed 5 Years. Book free. Write today.



Awarded Gold Medal First Prize at the International Gasoline & Oil Engine Show Budapest, Hungary

Burridge-Cooper Co., Ltd.
Engines, Gears, Pumps, Peerless Separators, Traction Engines, Grain Grinders and Power Washing Machines.

Winnipeg, Manitoba Regina, Saskatchewan

THIS

is the time to decide about a Lifting Jack for next season's work. Many a time last season you wanted a good Jack. The "Barth" Jack is a good Jack. And remember, we have been making Jacks for the farmer and thresherman for twenty years.

Ask your dealer for the "Barth" Jack. Write us for catalogue.

BARTH MFG. CO. MILWAUKEE, WIS.



MANITOBA WINTER FAIR AND FAT STOCK SHOW

BRANDON, MANITOBA

March 3rd to 7th, 1913

CANADA'S GREATEST WINTER FAIR

Horses, Cattle, Sheep, Swine, Poultry and Seed Grain. Stable accommodation for 500 horses and cattle, and display space for 5,000 birds.

Immense Show-ring Arena erected at a cost of \$120,000

Size of ring, 180 by 80 feet, surrounded by promenade and seating for 5,000 people; steam heated and brilliantly lighted.

HORSE SHOW EVERY NIGHT

EXHIBITS SOLICITED

ENTRIES CLOSE, FEBRUARY 20th

SINGLE FARE RATES ON ALL RAILWAYS

WRITE FOR PRIZE LIST

J. D. McGREGOR
President

W. I. SMALE
Secretary and Manager

**Based on
35 Years'
Engine
Building
Experience**

**Runs on
Kerosene,
Low Grade
Distillate
or Gasoline**

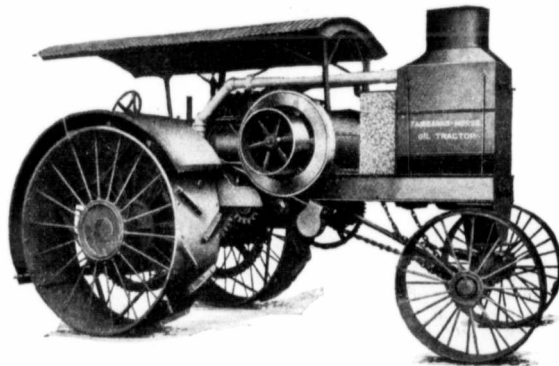

**FAIRBANKS-MORSE
OIL TRACTOR SCHOOLS**

Open to any one interested in Oil Engines.

Short complete course includes lectures and practical work.

School at Saskatoon opens Feb. 10 closes Feb. 22

School at Winnipeg opens Feb. 17 closes Feb. 22

School at Regina opens Mar. 2 closes Mar. 8

Write any of our offices for full particulars

The Tractor That's "BUILT TO LAST"

The Fairbanks-Morse Oil Tractors are built with ample strength to stand up under the heavy work and rough usage a tractor gets in service. They are made with a surplus of power for emergencies. They always develop more than full rated power at all ranges of speed on cheap low-grade fuel oils, as well as on gasoline.

In a Fairbanks-Morse Oil Tractor you have two speeds forward and one reverse, all controlled by a single lever. Its high efficiency is due to perfect design and construction of its engine, and the simple method of power transmission. Following are some of the features that count in giving you satisfactory service, when you own a

FAIRBANKS-MORSE OIL TRACTOR

Force Feed Lubrication—a strong, long life feature.
Sheet Steel Radiator with centrifugal pump—cools effectively with very little water.

Well Balanced Engine—No racking of frame, no heavy strains on gears, shafts or bearings.

All Parts Accessible—yet fully protected from dust and dirt.
Adjustable Spokes in drive wheels.

Guarantee—The well-known Fairbanks-Morse guarantee covering workmanship, materials and ability to deliver the power.

Our nearest office will promptly send catalogue upon request. It gives full descriptions of both the 15-30 and 30-60 Tractors, also letters from users telling of their experiences. We invite and will gladly answer any questions you may wish to ask. Remember that, whether plowing, threshing, hauling or harvesting, with a Fairbanks-Morse Oil Tractor, you save 70 per cent of the fuel expense, in other words,

\$30 worth of Fuel Oil will do the same work as \$100 worth of Gasoline

WE MANUFACTURE Fairbanks-Morse Oil Tractors, 15-30 and 30-60 H.P.
Binder Engines, adapted to all makes of Binders
Hand and Power Pumps for every purpose

Gasoline Engines, all types, Portable and Stationary, 1 to 500 H.P.
Marine Engines, 2 and 4 Cycle, 1 to 6 Cylinders
Truck and Pitless Wagon Scales

The Canadian Fairbanks-Morse Company, Limited

WINNIPEG SASKATOON CALGARY Montreal St. John Ottawa Toronto Vancouver Victoria

ONE of the first considerations that a purchaser of a traction engine has to decide, is the type of engine best suited to his farm. Whether he should buy an internal or external combustion engine should be settled first of all. The considerations in the case of the external combustion or steam engine, the cost of fuel in his district and the cost of water delivered to the engine as against the cost of gasoline delivered to an engine. The recent increase in the price of gasoline is going to make more purchasers seriously consider the steam engine.

Let us work out our costs of the steam engine first and the farmer can substitute his own figures in place of the figures given in this hypothetical case. Using the 1912 figures of the Winnipeg Motor Contest, we find that the steamers used all the way from 97½ pounds to 156 pounds per acre, the average being about 125 pounds of coal per acre plowed. The fuel used was a good type of American steam coal and if Western coal is used, it would probably have about 70 per cent of the heat value of the American coal which would bring the consumption up to about 173 pounds per acre plowed. Supposing coal in your neighborhood to cost \$6.00 per ton on your engine—this includes transporta-

On Purchasing a Tractor
By PROF. A. R. GREIG, Saskatchewan University

tion from the car and handling of the coal until it is in the bunker of the engine—it would mean a cost of 51.9 cents per acre.

One of the most important considerations is the question of water. No matter how cheap the coal is, if the water is not suitable for boiler purposes, it will make a steam engine an expensive proposition. Supposing that the water has to be hauled a distance of one mile, the team of horses with a 300-gallon tank should make a return trip in two hours. Supposing the value of team and teamster to be \$5.00 per day (10 hours), it would make our 300 gallons of water worth \$1.00, or one-third of a cent per gallon. The average water consumption last year was about 92.5 gallons per acre. This at one-third of a cent per gallon would equal approximately 31 cents and putting the cost of coal at 52 cents, it would make the cost of water 83 cents per acre. Taking the labor cost of engineer at 50 cents per hour and fireman 25 cents per

hour, makes full cost of labor 75 cents per hour. Allowing that we purchased a good sized steamer that could plow three acres per hour, this would give us a cost of 25 cents for labor per acre.

With a steam engine, there is always a little more work than with a gasoline engine, such as boiler washing, getting up steam in the morning, cleaning out flues, etc., the labor which together with incidentals should be taken into account. This additional labor together with the cost of oil and waste would probably run about 7 cents per acre, making a total of \$1.15. The quality of water should be taken into very careful consideration before a steam engine is purchased, as upon impurities held in suspension or solution, depend not only the economy of, but the life of the boiler itself. Some of the impurities and the character of the trouble caused together with the remedy will be found at the end of this article.

Now let us consider the internal

combustion engine. Gasoline has been going up in price recently, until it is probably costing the farmer on an average 30 cents per gallon. We find that the average consumption last year was 17.65 pounds per acre, and the gasoline used weighed 7 pounds per gallon. At a cost of 30 cents it would give us a cost of fuel per acre of approximately 76 cents. There was no water used in a number of cases, but the average amounted to 2.6 gallons per acre, which would approximate an additional cost of 1 cent per acre. This together with the cost of incidentals such as oil and waste would make an additional cost of 5 cents, making the total cost per acre 81 cents.

The labor cost would be one man at 50 cents per hour, and allowing 2½ acres per hour, it would give us a cost for labor of 20 cents per acre, bringing the total cost to \$1.01.

If a kerosene engine was purchased, we would save somewhat on the fuel, as kerosene can probably be bought for 19 cents per gallon, but we will use a little more of it, the average being 24.6 pounds. This would give us a fuel cost of about 59 cents per acre. The incidentals and additional labor would, however, be higher than in the case of a gasoline engine. Adding 20

**MOGUL
ENGINE
PLOWS**

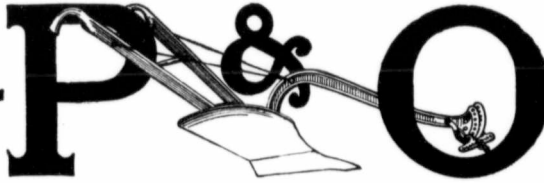

5 Sizes: 5-6-8
10 and 12 bottoms

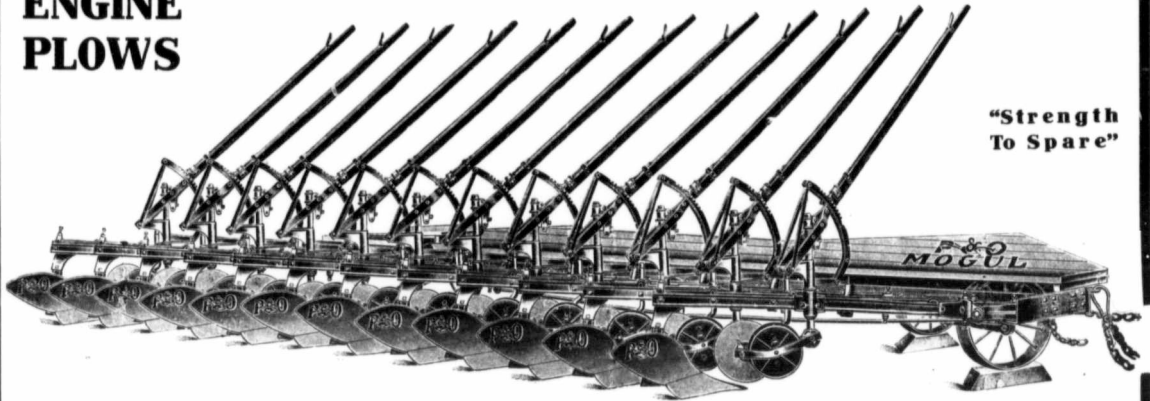

**"Strength
To Spare"**

STRENGTH

Those are your first impressions when you look at a Mogul. Those attributes have been wrought into the very appearance of the plow.

That the strength is there has been proven in the severest tests to which plows have ever been put. Every single part is designed to do just a little more than it will ever have to do, and you won't find a lot of metal piled into it just to deceive the eye, thereby overloading the engine with weight that isn't needed.

SYMMETRY—that's the word. Did you ever notice that the man who excels in strength and endurance is the one whose body is well proportioned—symmetrical? **THE MOGUL** is symmetrical. No one ever heard of a Mogul failing to make good because of a lack of strength.

And who are better able to judge as to its **EFFICIENCY** than those farmers, who, as judges, have awarded it so many prizes in plowing contests? The gauge wheels regula-

EFFICIENCY

ing the depth of each bottom separately, insuring even depth of plowing, and perfect bottoms, laying the soil over just alike in every furrow, could produce nothing else but perfect plowing.

As to **DURABILITY** it naturally follows that a plow, whose every part is designed to perform more than its share of work, is going to last. Just as the deep chested, clean cut, well proportioned man can stand hard knocks, arduous work, great exertion and yet live to a good old age.

We are proud of the Mogul and we feel that we are justly so, for no plow has so far fulfilled the hopes of its builders, nor given such universal satisfaction to its users. We will be glad to send a full description of the Mogul Plows to any one interested. Address Parlin & Orendorff Co., Canton, Ill., or

DURABILITY

The International Harvester Co. of America (Inc.), Sales Agents for Canada

cents for labor and 6 cents for water, oil and waste, would give us a cost of 85 cents per acre plowed.

Owing to the fact that the consumption of gasoline in the West is about four times that of kerosene and that the distillation of the crude oils gives us much more kerosene than gasoline, the tend-

ency will be more and more to increase the prices of gasoline and correspondingly reduce the price of kerosene. There has been more or less trouble with the kerosene engine up to date, but any one looking into future costs should take it seriously into consideration.

Troublesome Substances	Trouble	Remedy
1. Sediment, Mud Clay	Scale	Filtration and frequent blowing off of boiler.
2. Readily Soluble Salts	Scale	Blowing off, and the adding of a suitable boiler compound.
3. Acids in the Water	Corrosion	Adding of suitable Alkali Compound.
4. Organic Matter	Priming and Corrosion	Blowing off, and addition of suitable chemicals.

Touching the Spot
Extention Work in Saskatchewan

An Agricultural extention worker in trying to interest an audience of rural citizens sought to encourage them in the art of asking questions, and made the statement that the most careless agriculturist in the community could give pointers to his more efficient brethren along some line of his work. Not every man who succeeds is willing to adopt a portion of the philosophy of the failure, but that does not alter the fact that there may be much in that philosophy worthy of consideration and adoption.

If it were possible to get all classes in the community to get

together and exchange their good ideas the problems which affect the community would speedily vanish in thin air. Incidentally the work of the extension department of the College of Agriculture would move along rosy paths with all the thorns obliterated. This is the spot that the extension department aims to touch; the place where the shiftless man gets off, and his better equipped brother climbs higher into the band wagon.

The convention of Agricultural societies which is to be held in the College of Agriculture, Saskatoon, on February 4, 5, 6 and 7, aims to render all classes in the agricultural community more accessible to each other by creating a bond of sympathy between them. An effort is being made to assist the

delegates to this convention to throw off their crusts and come out in the open and express themselves. If extension workers in the past have not been able to do most effective work this has been the reason, that agriculturists are slow in coming out with their experiences and perplexities.

Therefore, the days of the convention will largely resolve themselves into field days in which the delegate and the visitor will be able to let themselves loose to

tackle without reserve the subject of rural problems. He knows them, and he has his ideas of what might be the solution of them. There will be every incentive, and there will be much inspiration. The readiest thinkers representing the people at large, from the Government of the province, from the University, and from the rank and file, will be there to encourage the man from the land to gird himself for the fray.

S. E. Greenway.



**Perfection
Tanning**

Nothing is Good Enough Unless it is As Well Done As it Can Be Done

We aim at perfection, and in the tanning of Hides, Skins and Furs, we believe we have reached perfection, or as near to it as human knowledge and skill can approach it.

If you have a hide or a pelt of any sort to be tanned for Coat, Robe, Gauntlets or Rug, we guarantee to do it perfectly and to give you complete satisfaction. We use no acids, only the purest and best bark and mineral extracts.

Let us prove our capabilities by a trial order and we know you will be glad to come again and to recommend us to all your neighbors

Send for our Raw Fur and Hide Report
We pay the highest prices

BRANDON TANNERY
Successors to Carruthers & Co.

BRANDON

MAN.

You saw this advertisement in this magazine. Don't forget to say so when writing.

Warning Words

By T. N. WILLING Saskatchewan University

THE prevailing idea seems to be that those beautiful snowy owls which may be seen about the prairie or resting on stacks of straw or grain are of more use when dead and mounted in glass cases than when enjoying life and liberty. These winter visitors are like other owls and most of the hawks, working in the best interests of the farmer while hunting the vast number of mice, moles and other rodents that constitute their food, but which, if not checked, will whittle down the profits of the farm. Sufficient help is a pressing need on the Western farm and it does seem absurd that voluntary assistance from the birds should be rewarded with shot; as well might we expect profit from the harvest hands by placing them in glass cases.

Protection of the birds of prey is not a matter of sentiment, but means dollars to the community. The more we alter natural conditions by the bringing of wild lands under cultivation, the more we require aid in checking the increase of creatures that find the altered conditions most favorable and the crop an abundant food supply.

Nature provided many checks on the increase of rodents, but the weasels, badgers, foxes, coyotes and other wild animals that preyed on mice, gophers, etc., are killed or driven off and we must beware that we do not loose also the aid of the birds.

Who that has worked in the harvest field has not noticed the dozens of mice under a stook and wondered perhaps what they lived on through the season? It was estimated by one of the Washington biologists that a field mouse consumes 24 to 36 pounds of green vegetation in a year, which would show that 1,000 mice in a field would eat about 12 tons of vegetation in a year. When it is realised that the increase from a single pair of mice might amount to about a million in five years if there were no checks, it behooves us to see that the checks are adequate.

One of the most successful of the owls as a mouser is the prairie owl, known as the short-eared, which is so commonly found nesting in hay meadows. An examination of 101 stomachs of this species by Dr. Fisher, showed 11 to contain small birds, 77 mice, 7 insects and 14 empty. Over a 100 field mice were in those 77 stomachs. Another scientist examined 51 stomachs and found in these remains of 90 injurious rodents. He also examined 480 of the pellets ejected by owls of this

Continued on page 42b

The Garden City Feeder

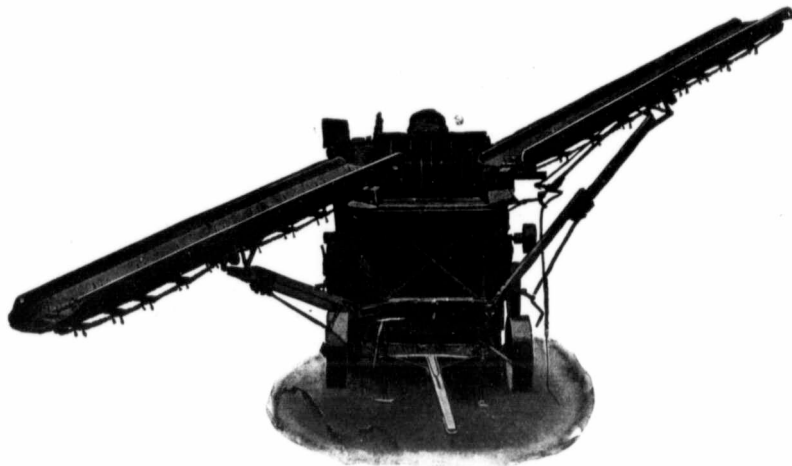

"MAKES GOOD" IN THE FIELD, THE PLACE WHERE OTHERS FAIL

BECAUSE,—It is built on **COMMON SENSE PLANS**

It will **BEAT** the mean or careless **PITCHERS EVERY TIME**

BECAUSE,—It will **NOT ALLOW** them to **OVERLOAD** the cylinder".

It will deliver every bundle to the cylinder **END FIRST**

BECAUSE,—It is **IMPOSSIBLE** for them to get there in any other way.

It will **PREVENT** slugging the cylinder, **BREAKING** concaves or spikes

BECAUSE,—It **ALWAYS** delivers just the **RIGHT** quantity to the cylinder, **NO MORE, NO**

LESS.

It will feed **EVENLY ALL THE TIME.** Let the boys pile on all they choose

BECAUSE,—Its **GOVERNOR** gets in its work **BEFORE** the grain reaches the cylinder.

It will **NOT WIND** on **ANY** part.

BECAUSE,—The retarder does **NOT REVOLVE** and **CANNOT** wind and all other parts are covered.

It will **PREVENT** breakdowns

BECAUSE,—It **NEVER OVERLOADS** the cylinder.

It will put **MORE** grain through, and do a **BETTER** job of feeding than any other feeder

BECAUSE,—It keeps the cylinder **FULLY SUPPLIED ALL THE TIME.**

It will **NEVER** cause a belt to **BURN** or **BREAK**

BECAUSE,—It has no **HIGH** speed parts to make it run hard

It will make **MONEY** and **FRIENDS** for **YOU**

BECAUSE,—It will make **YOUR** separator do its **FASTEST** and **BEST** work.

OUR FAMOUS IRON CLAD WARRANT CONTAINED IN EVERY ORDER WILL FULLY

PROTECT YOU.

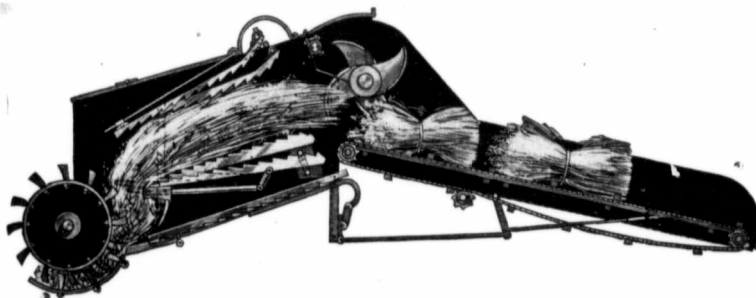

HERE IT IS

WE POSITIVELY WARRANT the **GARDEN CITY FEEDER** to feed any separator with any kind of grain in any condition to its full capacity, **WITHOUT** breaking any concaves or spikes, or slugging the cylinder, or winding on any part or causing any burned belts, and to deliver all bundles to the cylinder **END FIRST, REGARDLESS** of how they may be placed upon the carrier.

No other Company ever gave such a strong warrant, No other Feeder can **MAKE GOOD** on that warrant, they are **NOT BUILT RIGHT.**

DO NOT FORGET THAT THE GARDEN CITY WING FEEDER WILL SAVE YOU MONEY. Send for our new catalog. It is **FREE.**

THE GARDEN CITY FEEDER CO. Ltd.

REGINA

SASKATCHEWAN

Care of Farm Machinery

BY T. H. COLTART

THIS very important subject is not receiving the earnest attention from the farmers in Manitoba that it most emphatically merits. Much has been done in the past, through co-operative effort to remedy many anomalies in laws regarding the shipping and selling of grain; much remains to be done yet before we can say our "Nunc Dimittis." But the need at present, is for individual determination, energy and ceaseless industry applied to the problems which confront us at our own back door. Too long have we been content to shout with the agitators, only to fail them at the crucial moment, sacrificing both their and our success at one fell stroke. At the same time we have neglected very necessary and essential matters at home, which, if we had reduced to charity would in all likelihood have conspired to more enduring success and more acute appreciation from our business associates.

The time has come when all that causes leakages in the farmer's pocket must be eradicated. To many farmers in Manitoba the situation looks like this: The yield of grain is stationary while the expenses continue to mount higher year by year. He is therefore faced by a dwindling income. Retrenchment is imperative. Reform in antiquated methods is a prime necessity.

Let us imagine that the day is past when a farmer, realizing that his farm is not what it used to be in productiveness and cleanliness, resolves to trek westward where he may begin anew the crude and destructive method of wheat mining; instead he casts around with careful scrutiny all avenues that are depleting his hard earned deposit. He notes, for instance, that there is much empty land along fences and in out of the way places which has never been broken up. With the hired man or his husky sons acting as a reducing agent these waste places are brought into subjection and the land yields its increase as aforesaid. In the process many noxious weeds are exterminated. Again, the roadsides claim attention. In the past from this source has come many of the most persistent of his botanical enemies. But the fiat has gone forth and the penalty exacted is death and annihilation. His archaic methods of tillage are relegated to oblivion never to be resurrected.

He is impressed with the poten-

tiality of the manure pile and he proceeds to deal with it intelligently, thus reaping an immediate benefit therefrom.

And lastly, he begins to get a glimpse of the rank waste that is going on in his varied and extensive list of farm machinery through simple unadulterated carelessness.

Having attended to all these details with energy and dispatch he is surprised to find that his farm has many subtle attractions which aforesaid he had never dreamed of it possessing, even in his wildest flights of imagination. He has commenced a new era in his farming operations and the impetus received is going to be far reaching and cumulative in its effects.

To examine in detail the care of farm machinery and to indicate its extreme importance we shall first of all deal with it from an economic standpoint. There are two factors which ought to be considered very seriously. The first is the huge initial outlay incurred in the purchase of farm implements and machinery. For an ordinary section of land it takes approximately \$2,500 which does not include a threshing outfit. Horses and machinery are the most costly items concerned in the operation of a farm, but machinery takes first place in this respect.

The second factor is the comparatively short life of most implements, thus demanding periodic renewals. It is obvious that anything which conduces to longer life is going to be an economical gain.

What does housing do towards lengthening the period of efficiency in implements.

1. It protects from rapid oxidation. Implements that are exposed to sunshine, wind, rain, snow and frost are not long in manifesting signs of rapid deterioration. Implements represent too much capital to be lying around promiscuously subjected to the elements of heaven and the destructively mechanical agency of horses and cattle. These furthermore are liable themselves to serious injury from plow shares or knives of any description.

When an implement is not warped, bent, twisted or corroded it is going to run smoother and do a thoroughly satisfactory and complete job. Time will be saved when there are no corroded landslides and moldboards to scour at every headland. Time and money saved when grain boxes are grain tight and not warped and shrunken-

NOT ONE, NOR TWO, BUT FIVE YEARS' GUARANTEE GOES WITH THIS ENGINE!

When you buy a gasoline engine, get the latest type made, with a five year guarantee to back it. The Renfrew Standard is the result of 21 years experience in engine building, and in advance of anything yet produced. We could not sell an engine on a five years guarantee unless all materials were first-class, workmanship highly skilled, and the performance of the engine perfect in every respect.

The Renfrew Standard

Made in sizes, 2½ to 40 H.P.

Semi-Portable (as illustrated) also Stationary and Portable.

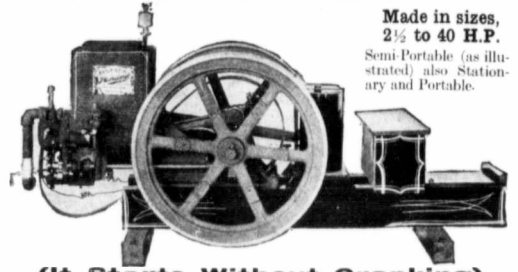

(It Starts Without Cranking)

is a perfectly balanced, durable, economical engine for farm work. It starts readily in cold weather, without cranking, thus doing away with the most troublesome, laborious and dangerous feature of ordinary farm engines. The Carburettor is of simple design and positively ensures the correct mixture to obtain best results. The perfect balance of the RENFREW STANDARD is a great factor in its long life, as all racking vibration is done away with. The Governor is automatic, permitting of closest regulation, and enabling you to change speed by simply turning a convenient thumb-screw, without stopping the engine. The RENFREW STANDARD engine is made and guaranteed by the same firm that makes the famous STANDARD separator. Send us your name and address for a copy of our engine bulletin, which deals fully with every point of superiority in RENFREW STANDARD Engines. Write us to-day

The Renfrew Machinery Co. Ltd.
Endernton Block - - Winnipeg, Man.

You saw this advertisement in this magazine. Don't forget to say so when writing.

The vital part of a plow is the plow "bottom." The high standing of John Deere plows rests on the excellence of the John Deere "bottom."



plow shares (quick detachable) are the greatest convenience ever put on a plow. They are the latest, simplest, strongest. Find out all about them. Write for booklet at once.

John Deere "Shares"
For New Deere Sulky and Gangs

Saves 80 per cent of the time required to change an ordinary share.  means quick detachable - quick attachable, too. On and off quick is the idea.

Only one nut to remove. That nut is handy to reach, too. Glance at the picture. Take this one nut off and the share comes off. Slip the sharp share on and tighten up nut. Don't waste time changing old style shares. You really can't afford to. When you see this new share you won't want to.

New and Exclusive John Deere Feature

Found only on John Deere Sulky and Gang Plows. The art of making plow bottoms is most highly developed in John Deere product as now equipped with the new and exclusive  share. John Deere plows, always good plows, always the very latest, always the most modern.

Write for  Book - mailed free - No.

John Deere Plow Co., Moline, Ill.



You saw this advertisement in this magazine. Don't forget to say so when writing.

Hart-Brown Wing Carriers Hart Universal Thresher Racks

NOW SOLD IN CANADA BY

Haug Bros. & Nellerhoe Company
Winnipeg, Regina and Calgary



The Hart-Brown Wing Carrier, which can be attached to any separator with any feeder, delivers the bundles to the machine straighter and more evenly than is done by hand, eliminating slugging and decreasing strain on entire machine.

The carriers are under control of the feeder governor and start and stop with feeder conveyor.

YOU CAN SAVE \$30.00 to \$40.00 A DAY BY USING THESE DEVICES.

The Hart Universal Thresher Rack should be used with the Carriers. They unload instantly by a pull off gate. No time wasted at machine. One Hart Universal and driver will do as much work as two ordinary racks and drivers.

Write Haug Bros. & Nellerhoe Co. for catalog and full particulars.

DEALERS WANTED IN UNOCCUPIED TERRITORIES

HART GRAIN WEIGHER CO., Peoria, Illinois, U.S.A.

You saw this advertisement in this magazine. Don't forget to say so when writing.

en and hence unreliable. Binders run twice as long when they are kept under cover continuously. Repairs in this case are only nominal.

From an authentic standpoint the house that has all its implements under cover is much more attractive to the visitor who has imbibed very arrogant and supercilious views regarding farm life, it is a most agreeable surprise to find everything neat and in order.

The impression is a pleasing one.

The farmer and his family also reap an undoubted benefit. What was once a hideous panorama of implements in various stages of decrepitude, reclining indiscriminately over the face of the farmyard is now a scene indicative of solid progress and careful management.

The reflex influence is seen in all departments of the work. There is an indefinable air about the farmstead which tends to eliminate careless haphazard methods in farm practice. Windbreaks, gardens, lawns and ornamentation attest subconsciously to this conception.

There is also an educational value which attaches itself to the proper handling of farm machinery. In brief it may be seen in the increased attention that is

paid to the proper working and understanding of the different parts. There is an enthusiasm created which has its counterpart in the quality of the work that is accomplished. The plowing is straighter, deeper, and more level.

The seeding is done with an eye to futurity, when its perfections shall be open to the gaze of the critics. The cutting is accelerated because the operator handles the binder with the ease born of complete mastery.

Thus we see that educational training and true economy in operation go hand in hand. These are the qualities which are in demand today all over the business world and nowhere, are they more urgently needed than in the Farmers of the "last Great West."



The Hottest Day on Record.

A party of Leland Stanford students paused on the rim of the crater of Vesuvius. As they peered into the seething mass of horror below them, one exclaimed in an awed tone: "Don't that beat hell?"

Some Englishwomen were standing near and evidently overheard. One of them remarked to the others in her well-bred, distinct voice: "Isn't it remarkable how widely these Americans travel!"

Good Roads for Manitoba

Continued from page 32

taken last summer when the Meridian road was officially inspected by the heads of the Meridian road executive. The inspection was started at Winnipeg and the flag was carried from this city to Pembina, N.D., by an escort of Winnipeg motorists consisting of ex-Mayor Waugh, A. McGillivray, Mayor Berry, W. F. Tallman, F. E. H. Luke and A. C. Emmett. From Pembina the official party and flag were carried on by relays of automobiles supplied by the different state divisions, until a message sent by Mayor Waugh of Winnipeg was placed in the hands of the Mayor of Galveston on December 13, 1912. The whole trip of over 2,000 miles was made by automobile and revealed the fact that it was possible to place this highway in good condition for travel, at a moderate cost if every division was working in harmony and sympathy with its neighbors north and south.

The Good Roads Act

The fact that there are two different Acts applying to the construction of roads in the province of Manitoba, has led to a certain amount of confusion in the discussion of measures regarding

the adoption of good roads by-laws. One Act is known as the Highways Improvement Act and municipalities placing themselves under its provisions are entitled to a grant from the provincial government equal to two-thirds of the total cost of the work performed in the construction of permanent highways.

Under the Good Roads Act, which covers practically every class of work in connection with the ordinary graded mud road, the municipalities are granted a sum equal to twenty-five per cent of the entire cost, including the cost of draining and ditching, supply of material, machinery, etc.

Many of the municipalities around Winnipeg have taken advantage of one or other of these acts and a number of the Western municipalities are placing by-laws before the people, which if carried, will allow of their also commencing a good roads campaign.

Work in Progress

On the west side of the City of Winnipeg, the Municipality of Assiniboia will complete the bitulithic pavement to the municipal hall at St. Charles, and will have a gravel road from that point to the extreme western limit of the municipality beyond Headingly.

Best and Cheapest Farm Power

CHEAPEST by a long way in comparison with anything else in Power Machinery made in

"The Stover" Gasoline Engine

BECAUSE it is the most reliable and efficient gasoline engine you can buy at anywhere near the price. It is the greatest fuel economist of them all, and is absolutely dependable.

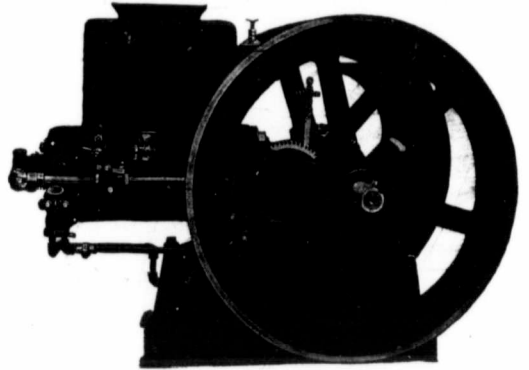

Simple in Construction. The Smoothest Worker Going

Our complete line of Stationary, Portable and Traction Engines means plenty of power for all purposes on the farm. Our full list includes Fuller & Johnson repairs; repairs for the Wilkinson Plow Line; Shares for all kinds of plows. 12-inch, \$2.25 each; 14-inch, \$2.50 each; 16-inch, \$2.75 each. Engines for pumping, churning, crushing, grain cleaning, sawing, threshing, and running washing machines. In fact, we handle EVERY KNOWN FARM REQUISITE.

Write for Catalogue and state your wants. Have your mail addressed to us when you visit Brandon.

CANADIAN STOVER GASOLINE ENGINE CO. Ltd.

EIGHTH AND PACIFIC AVENUE, BRANDON

The Original Farmers Company

Agents for Minneapolis line of Threshing Machinery.

COUPON

Canadian Stover Gasoline Engine Co., Brandon: Please send me Catalogue of your Engines and Sundries, as advertised in the "Canadian Thresherman and Farmer."

Name

Post Office

Warning Words

Continued from page 41

species and found remains of 871 mice and voles.

More easily noticed is the injury to crops from the several species of gophers, and of most value for the control of these are the large hawks known as the rough-legged, the ferruginous roughly and the Swainson hawk.

It may be seasonable advice to remind farmers that poisoning of gophers is best done when the snow is still on the ground and the little animals are out, hungry and keen for any food available after their winter sleep. Get a supply of strychnine in time and use it before the gophers have time to increase. A good formula for the preparation of the poison is 1 oz. strychnia sulphate, 30 lbs. wheat, 2 gals. water. Dissolve the strychnine in the hot water, add a little molasses and pour over the wheat. Let it stand over night and then add some fine meal to take up any surplus moisture. Distribute a spoonful to a hole. Do not use the bread pan or other cooking utensil for mixing the poison in, as accidents have happened in such a way.

Another good reason for protecting the birds of prey is that we shall soon require all the assistance available to resist the advance of the rats which have already made their appearance in

southern Manitoba. This is no trifling matter, as the damage done by rats where they are established, is enormous, both in the country and in the cities. The estimated loss from rats annually in the United States is over twenty millions of dollars. Can we afford to assume by negligence a similar tax, or shall we, being warned in time, adopt measures for resisting the advance of these disgusting carriers of disease.

Innovations

Every good thing has been condemned in its day and generation.

Every innovation has to fight for its life.

Error once set in motion continues indefinitely, unless blocked by a stronger force, and old methods of thinking and doing will always remain unless some one invents a new and better way and then lives and dies for it.

And the reason men oppose progress is not that they hate progress, but that they love inertia.

Even as great a man as John Ruskin foresaw that the railroads would ruin England by driving the stages out of business and killing the demand for horses, thus bankrupting the farmer.

Thomas Jefferson tells us, in his autobiography, of a neighbor of his who "was agin" the public schools because, when everyone could read and write, no one would work.

Sir William Berkley thanked God there was not a printing-press in Virginia, because printing-presses printed mostly lies, and their business was to deceive the people.

In the time of Mozart, musicians were classed with stablemen, scullions, clowns and cooks. They ate below stairs, and their business was to amuse the great man who hired them and his assembled guests.

The word business was first used in the time of Chaucer to express contempt for people who were useful. The word was then spelled busyness.

To light cities by gas would set them afire.

Electricity was dangerous, and to put up wires was to invite the lightning to come into our houses and kill us all.

Only a few decades ago any man who advertised in the newspapers was looked upon with suspicion, and even yet we have associations of professional men who stamp with their disapproval any individual among them who pays for his advertising.

Such a one was called an "irregular."

If we look back through history we will find that every good and beautiful thing has at one time or another been under the ban, and assailed as an evil.

And the argument seems to be this: if you think a thing is right, never mind what the many say, stand by it.



Salt in Poultry Food

Many people labor under the mistaken impression that salt should never be put into poultry food, simply because highly salted food, such as salt fish or old pickled meat, always kills chickens. As a matter of fact, no living thing can get along entirely without salt. Chickens can always get salt in summer by eating grass, which absorbs a certain amount from the soil. But in winter it is different. During cold weather, all prepared chicken foods, such as mashes and boiled vegetables, should be salted in about the same proportion as for human food. If this is done, the poultry will be both healthier and more productive.



Age, with his eyes in the back of his head, thinks it wisdom to see the bogs through which he floundered while he was looking forward.

GEISER "New Peerless" Sieveless Separator—the threshing machine with the most perfect cleaning system in the world. The man who owns a GEISER makes *more* money—with *less* work and *trouble*.

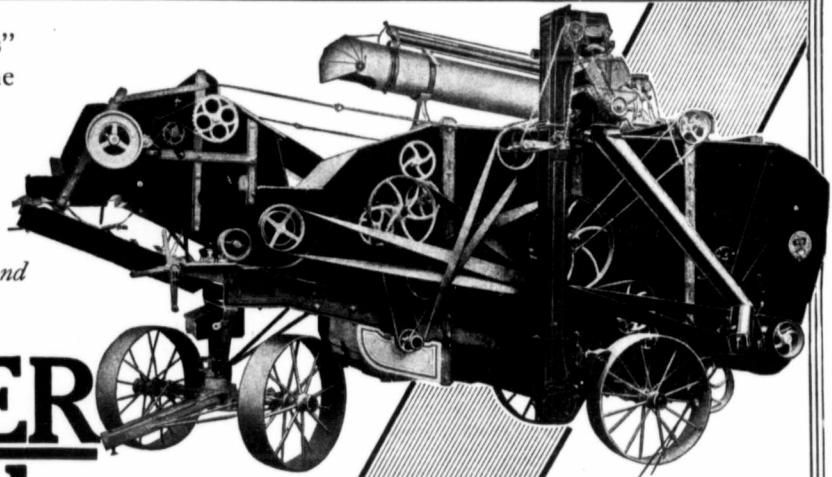

GEISER Threshers

The "New Peerless" Sieveless Separator is the one that insures *perfect cleaning* by the proper gravity system without compelling the thresherman to stop and make changes for different grains, take out and put in sieves and riddles, or load and haul these attachments from place to place. This machine gives you the *sure* way to *clean thoroughly*—at the same time making the work easier for the operator, enabling him to do *more* work in a day and make *more* money.

The "New Peerless" carries a feeder built especially for this machine—a feeder that gives *good service always—trouble never*. A strong feature on this machine is the Separating Drum, which *takes 95 per cent of the grain from the straw*, leaving the smallest possible amount of work for the straw racks and grain bottoms.

Strongest cylinder on a thresher—flaring hopper, feeds from end to end of cylinder; all bearings very large and self-adjusting—concaves adjustable front and rear—positive governor on feeder controls speed of carrier—rotary knife or disc band cutter as desired—telescoping and automatic Peerless Wind Stack—15 double steel bars on cylinder, with two middle heads keyed to shaft like outer heads—cylinder sides of iron, weather proof.

General construction—GEISER! That means quality in materials, skilled workmanship—perfect, reliable money-making service.

GEISER Engines

The successful use of GEISER "Peerless" Steam Engines, season after season, by hundreds of satisfied, prosperous owners, led us to make this statement a long time ago: "Power troubles are ended when a 'Peerless' engine is hitched to your machinery."
We stick to that statement!

This engine will transmit more of the total power developed in the steam cylinder to the rim of the traction wheels than any other engine ever built.

We stick to that, too!

GEISER engines have all-steel compensating gear with shock-absorbing elastic steel springs—patented adjustable wheels, a wedge take-up on the spokes keeping each wheel rigid. We also make the greatest spring-mounted engine, for hilly, rough country.

Important! The "Peerless" is the only traction engine having a fire-box boiler that retains the water on crown sheet when pulling *down* hill and keeps the front end of tubes covered when going *up* hill. You threshermen know what can happen to a boiler when the crown sheets become bare of water.

Boiler seams double-riveted—boiler re-inforced by inside sheets to stand extra strain—strongest, most durable boiler possible to make—easy to clean on account of its open bottom.

GEISER engines are made in single and double cylinder—also double geared with drive on both sides.

GEISER "Peerless" Traction Engine—the one that eliminates power troubles.

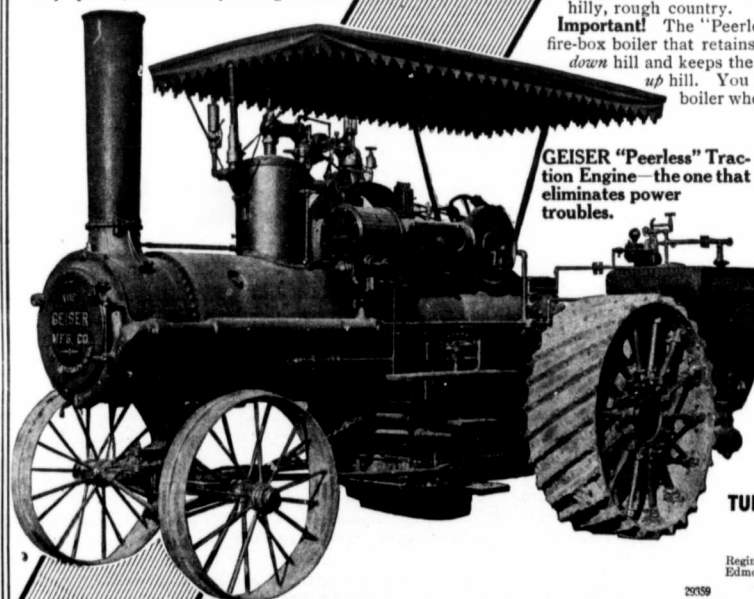

Send For Free Books

Don't delay writing—don't buy until you have received and read the GEISER books. Write *today*.

Emerson-Brantingham Implement Company

The Largest Line of Farm Machinery in the World
ROCKFORD, ILLINOIS, U.S.A.

TUDHOPE, ANDERSON & CO., LTD.
1199 Princess Street, Winnipeg, Man., Canadian
Sales Agents.

Regina, Sask. Saskatoon, Sask. Calgary, Alta.
Edmonton, Alta. Lethbridge, Alta. Brandon, Man.
Yorkton, Sask. Swift Current, Sask.

PRACTICAL TALKS TO THRESHERMEN

CONDUCTED BY PROFESSOR P. S. ROSE

Talk No. LXVI

Note.—The term "gas engine" in these lessons will be used indiscriminately in speaking about all internal combustion engines.

THE development of the gas tractor started in England and France along in the '90's and in this country about the year '98 and '99. The Hart-Parr Company, of Charles City, Iowa, and the Kinnard Haines Company, of Minneapolis, are the two pioneer companies in America. It took both of them five or six years after the first machine was built to eliminate the weaknesses and build a really serviceable machine. It was not until 1906 that either of these companies felt they had the problem solved.

The making of a traction engine is not as simple a matter as it appears to be. There are many people who fancy all there is to it is to take any ordinary engine and mount it on a wagon and put in some sort of gears or chain for a transmission mechanism. As a matter of fact the problem is not an easy one. If it were as simple as these folks fancy, it would not have taken fifteen years to bring the tractor to its present state of efficiency. The problem of the light weight tractor would not be bothering anybody.

As a matter of fact, there hasn't been any harder piece of development work attempted than the one of designing a reliable, efficient gas tractor. The difficulty has been that no one could estimate in advance the stresses incident to tractor work. All the early transmission systems were weak and when strengthened sufficiently with ordinary metal they were heavy and unwieldy. Even the motor used in stationary practice was inadequate. Success has been attained through experimentation and by giving the closest attention to every detail of construction. Considerable was learned from the automobile people, but the work of the tractor is so much different from that of the automobile that the latter type of machine merely served to illustrate a few of the fundamental principles. The automobile motor rarely runs for more than a few moments at a time under full load or at a constant speed. The motor of the tractor, on the other hand, when used to plowing runs at its full capacity hour after hour. It is very evident that a motor which would give excellent service in an automobile would prove entirely unsuited to tractor purposes.

The tractor motor must have ample cooling space, a very efficient radiator and be built strong and substantial. In other words, it must be a heavy duty type of machine. There must be no small

parts which can be put out of adjustment by vibration, none that are easily broken by the shaking of the machine or that will be sheared off through the ordinary rough usage of the field. All trappy construction must be eliminated and only the simplest strongest, and most easily accessible details can be allowed. The sizes of shaft, of connecting rod and of gearing that are suitable for ordinary stationary work were long ago proven inadequate for the traction engine. The load which the tractor must carry is not uniform but on the contrary very irregular. The soil may be loose and easy to work in one part of the field and in another exceedingly difficult. The plows may be cutting freely and strike an obstruction that will stop the entire machine. These stresses are frequently abnormal and it requires excessive strength in the machine in all parts to insure safety. Then there are vibrational stresses that are beyond the power of computation. The running of an engine over hard ground that is full of stone or that contains the multitude of small hummocks that are found in our Western plains will shake it to pieces unless it is built exceedingly well. Everything that can be riveted should be so secured and where rivets are not used every bolt should have a jamb nut and the jamb nut should be keyed. Most all of the best tractors are now made in this way but it has taken a good many years for designers to learn all of the essential details which go to make up a successful machine. Even yet there is much to be learned, especially when it comes to designing the small sized tractors and those of light weight. They require great strength and strength is hard to attain without considerable weight.

There is another thing in the matter of tractor design that many people do not take into consideration. They look at one of these crude machines and compare it with a fine stationary engine or automobile and immediately conclude that what is needed in the tractor field is refinement of design and better workmanship. Here is where they make a mistake. Fine design for the heaviest, roughest work would not do at all. The type of construction used in a locomotive is crude in comparison with that in a triple expansion, high speed steam engine. The latter is a marvel of fine workmanship, exquisite design and high economy. If the

ideas of design and construction were carried out in the locomotive the results would be mighty disappointing. Exposed to the dust and grit and vibration of the road a fine built machine would soon go to pieces. Engineers who examine and criticize agricultural machinery and especially tractors must never forget that the best engineering consists in adapting the machine to the work where it will be used.

Right here is where mistakes are liable to occur in any public competition where construction and design must be taken into consideration. The ideals of design and construction cannot be the same in a tool room or an instrument factory. They must be adapted to the soil and to the big out-of-doors. There are a number of features that should be agreed upon, such as quality of materials, the use of rivets or locked nuts, adequate means for lubrication, etc., but when it comes to workmanship and broad features of design, exceeding care and ripe judgment must be exercised or the award will appear foolish to those who know.

The first tractors to be developed were the heavy machines equal in capacity to the large steam tractors. It was only natural that this should be true because, in the first place, the purchasers had been educated to want powerful engines and they were needed for the large grain farms in the West; second, it was easier to build large machines with adequate strength than small ones, because there was no restriction so far as weight was concerned; third, and this was one of the principal reasons, there was much more profit in the large machines. It takes no greater shop equipment, no more labor, and no greater selling expense to manufacture and market large machines than it does small ones. The additional cost is mainly in the weight of the raw material used, while the price and the profit is much greater.

For several years there was no consistent effort made to develop a light weight tractor, but with the entry into the field of about seventy companies, which is approximately the present number, competition and the effect of a long educational campaign has turned the attention of designers strongly to the light tractor. Furthermore, the need for more power to carry out the ideas of scientific agriculturists, together with the high price of horses, has intensified the movement. There

are now several quite highly developed light tractors on the market weighing five tons or less. They will undoubtedly require some strengthening in certain minor details, but another year at the latest ought to see them fully equal in reliability to the heavy machines.

There are now two principal types of machines; the two cylinder, either twin or opposed, and the four cylinder. Both have their advocates and both are good machines. It is too early as yet to prophecy which will ultimately survive. Perhaps both will, possibly only one. This fact must not be lost sight of, however, in any forecast. Both types have gone through a period of development covering the same length of time and both have stood the test of time in the field. One thing is certain, since a ten-inch cylinder is about the limit for oil fuel engines, anything larger than 50 or 60-horse power will necessarily have to be of the four cylinder type. Among smaller sizes there is a choice between two and four cylinders.

Since these lessons are for the purpose of merely showing the present development of the art, the writer will not assume the risk of prophecy.

The next lesson will deal with some of the social and economic aspects of the power farming, and then pass on to mechanical details.



W. J. ("Fingy") Connors, the New York politician, who is not precisely a Chesterfield, secured his first great freight-handling contract when he was a roustabout on the Buffalo docks. When the job was about to begin he called a thousand burly "dock-wallopers" to order, as narrated by one of his business friends: "Now," roared Connors, "ye are to worruk for me, and I want every man here to understand what's what. I kin lick anny man in the gang."

Nine hundred and niety-nine swallowed the insult, but one huge, double-fisted warrior moved uneasily, and stepping from the line, he said, "You can't lick me, Jim Connors."

"I can't, can't I?" bellowed "Fingy."

"No, you can't," was the determined response.

"Oh, well, thin, go to the office and get your money," said "Fingy." "I'll have no man in me gang that I can't lick."

OIL-GAS TRACTOR

Strong, Simple and Powerful

Burns Kerosene

Compactly built, yet plenty of wrench room. No gears running idle when used in a belt. No bevel gears in the driving mechanism. Guides as easily when plowing as it does on the road. Runs steadily and smoothly in the belt, making it highly practical for threshing.

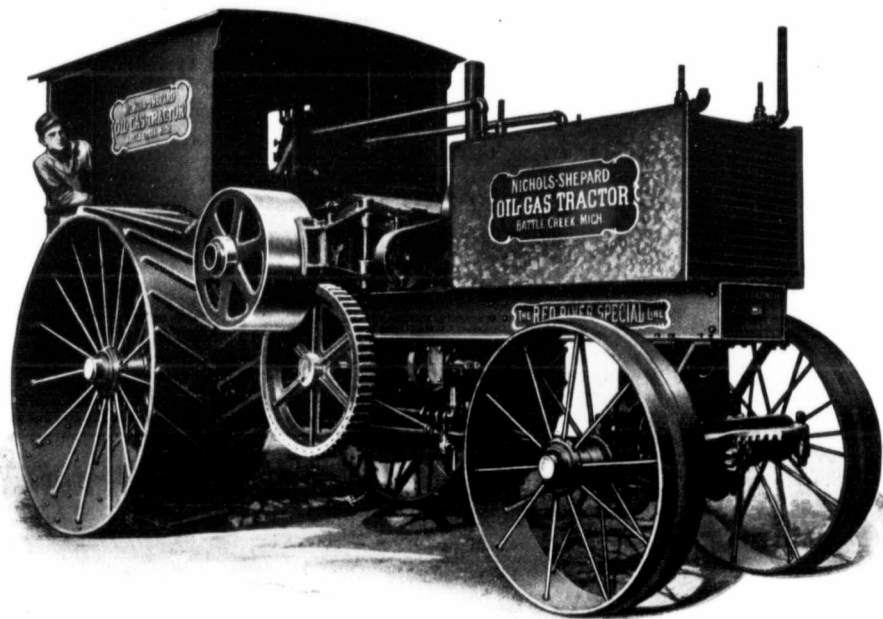

Nichols-Shepard OIL-GAS TRACTOR. Built in 22 and 35-horse sizes.

JOHN SEGERBORG, of Rolla, North Dakota, writes:

"Your Tractor is the only one for long service. Everything is just as strong and simple as a steam engine.

It is not delicate and complicated like the high-speed tractors some build. There is no chance that they can stand the work. Some of them are sold cheap, but are high-priced at that.

The one good feature of your OIL-GAS TRACTOR is starting it in cold weather. I live in the extreme north, close to the Canadian boundary, and we threshed late last fall. We started the tractor just as easily the coldest morning as we did any other morning.

I would advise anyone to buy it and they will find my judgment right."

If you want a tractor to plow with or to thresh with, write for our OIL-GAS TRACTOR Catalogue. It gives full particulars.

NICHOLS & SHEPARD COMPANY BATTLE CREEK, MICH.

Sole builders of the Red River Special Line of Red River Special Threshers, Nichols-Shepard Traction Engines, Oil-Gas Tractors, Universal Self Feeders, Stackers, Weighers and Supplies

WINNIPEG, MAN.; REGINA, SASK.; CALGARY, ALTA.

You saw this advertisement in this magazine. Don't forget to say so when writing.

The
**Thresherman's Question
 Drawer**

ANSWERS TO CORRESPONDENTS

Q. I have a compound engine which has a double oil pump, one part of which supplies the high pressure and the other part supplies the low pressure cylinders. Both plungers of the pump are driven with one shaft, there being two eccentrics on the shaft. Now, the trouble is, both pumps do not deliver the same amount of oil, yet they should have the same capacity, as the plungers are the same diameter and have the same stroke. The pump has no valve in it, but there are two valves on the delivery pipe leading to the high pressure cylinder and one in the pipe leading to the low pressure cylinder. The plunger which delivers the oil to the high pressure cylinder gets the lesser amount of oil, and, in fact, to get a sufficient quantity to lubricate it properly, I have to run the pump so fast that the low pressure cylinder is flooded with oil, and in consequence there is a waste of oil. I have changed the connections and valves of the pump so that the plunger which delivered oil to the low pressure cylinder was connected to the high pressure cylinder, thinking this would help, but the trouble was about the same—the low pressure cylinder got much more oil than the high pressure cylinder.

Now, how can I get the pump to deliver the same amount of oil to each cylinder? If the pump is tight, should the difference in pressure of the cylinders make so much difference in the quantity of oil pumped? I would be grateful for any help you can give me in this matter.

A. The plunger of your pump must leak. Leaky check valves would also cause this trouble, but as you changed the delivery pipes and also the check valves, the trouble seems to be in the plungers. Tight fitting plungers in the pump may help you, as the oil is solid enough to not be influenced so much by the difference in the pressure of the two cylinders. A better plan would be to have a separate pump for each cylinder. Then you could run each one the required speed to deliver the quantity of oil desired.

Q. Please explain to me how to fire a straw-burning firebox boiler, and why the flues get to leaking so easily when straw is used for fuel?

A. There is nothing which will worry a man so much as trying to fire a boiler with straw, when he does not understand the art, but a free steamer in the hands of an expert fireman is an easy job. One can make a great deal of extra work for himself by stirring the fire too much, thus making an extra amount of clinkers on the grates and stopping up the tubes at the tube sheet. A poor fireman who keeps lifting the firing fork will have to clean off the tube sheet as often as six times an hour; while a good fireman will not clean the tube sheet any oftener than once in two or three hours.

One of the important points (as in firing with wood or coal), is to keep the grates well covered, that is, not leave any dead space for cold air to rush into the firebox. If the firebox is wide, one can be sure that the grate is always covered by placing a fork full on one side, the next one on the other side, and then one in the middle, and if this is kept up there is no danger of leaving any bare places on the grates. Too many firemen push all the straw to the center and poor results are sure to follow.

We have warned you against stirring the fire; yet there is some stirring needed. After the grates are well covered with ashes or clinkers (which will be noticed by the fuel of the fork while the straw is being pushed in, mainly on account of the straw not burning so freely), the fork can be put under the fire, with the points of the tines turned downward, and the ashes or clinkers can be pushed through the grates without disturbing the fire very much. This will allow the air to get to the fire again and make it burn freely, which will be noticed when the next straw is placed in the firebox.

The draught door, or ash pan door, is made large enough to pull the ashes out, which should be done from time to time, but the ash or draught door should not be kept wide open. An inch opening is generally sufficient to admit enough air for easy steaming, and whenever firing is stopped the draught door should be shut down. At first glance this may seem to be of little account, but straw for fuel makes a very uneven heat. While the average heat is sufficient to keep up the steam, yet at times the heat is

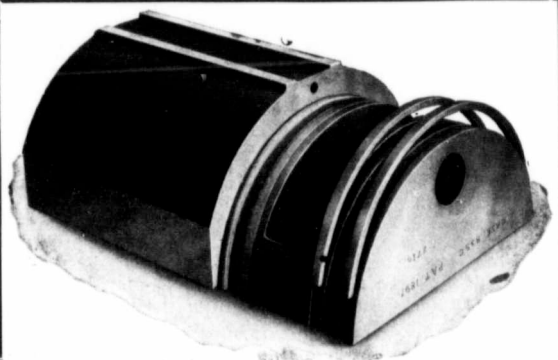

We Have "The Evidence"
— Positive Proof —

That the **GOULD BALANCE VALVE** does show a gain from 15% to 30% over a common slide valve.
 10,000 **USERS** of the **GOULD BALANCE VALVE** in every State and Province of America attest to this guarantee.

A post card with your name and address brings this "Evidence" to you.

WRITE US TODAY
Gould Balance Valve Company
 KELLOGG, IOWA, U.S.A.
 1,000 Agents Wanted Write for Contract

You saw this advertisement in this magazine. Don't forget to say so when writing.

Special Cold Water Ejector



For elevating large quantities of water quickly and without raising the temperature, we have designed our No. 77 Ejector, which will elevate 3,600 gallons of water per hour with scarcely any increase in temperature. This Ejector is a necessity for engineers who have been bothered with hot water.

Ask your dealer, or write us for particulars
DESMOND-STEPHAN MFG. CO., Urbana, Ohio

You saw this advertisement in this magazine. Don't forget to say so when writing.

Sawyer-Massey Co.
NOT
IN A COMBINE!

much greater than when burning wood or coal. Thus the flue sheet and flues are heated to a very high temperature at times, and if, while the engine is yet running, the exhaust is allowed to draw much cold air through the firebox and into the tubes, we can then see where the trouble comes from. There is nothing which will make these tubes leak so quickly as getting them real hot and then allowing cold air to strike them while in a heated condition. The beads of the tubes are exposed, and being so much thinner than the tube sheet thus become loosened. After this occurs a number of times the tubes will become so loose that they will rattle in the tube sheet when the boiler cools down.

An imperfect fire chute door will also cause this trouble. It sometimes happens that the door in the chute will stick. Firing does no harm in this condition, especially when the chute is kept full of straw, but when firing is stopped, the straw will burn out of the chute and, the door refusing to drop, cold air will rush in and the tubes will be sure to be damaged.

In burning straw the ash door should be kept closed as far as possible, only allowing it to open far enough to burn the straw, and it is surprising to see how little a space is sufficient to admit the required amount of air.



Q. I have a cone screen in my stack and when I use it, it retards the draught so that the boiler steams very hard. Can there be anything done to help the steaming quality of the boiler when using the screen?

A. The draught can be increased by reducing the exhaust nozzle. Another way to help the draught while using the screen is to invert it. Instead of having it to extend downward in the stack, turn it upward. Thus the smoke will have an easier outlet and you will find the draught much stronger, and good results may be had in this way without reducing the exhaust nozzle.



Q. I would like to know why the governor on a compound engine does not control engine as perfectly as on a simple. I am using a Pickering governor.

A. A compound engine is not so quick to respond to a load as is a simple engine; as the steam is admitted to the high pressure or small cylinder and the low pressure or large cylinder does not receive the steam till after it gets through the high pressure cylinder, and the full power of the engine is only realized after both cylinders are at work. However, the economy of a compound engine should more than make up

REEVES Engine Gang Plow

SUCCESSFUL work under all conditions—never known to fail! That's the record of the REEVES Engine Gang Plow. No user of a REEVES ever found a job it wouldn't walk away with—in any kind of ground—with any sort of power—in any circumstance that could arise in traction plowing. The REEVES is invariably *there at the finish*—with the plowing perfectly done. We tell you this is the plow that succeeds when all others fail—that it is

The Plow That Made Traction Plowing a Success

We have the experiences of thousands of satisfied users to *prove* this claim. Before the Reeves came, traction plowing was a frequent cause of grief because bad ground conditions caused loss of time—breakage—inferior work. But the REEVES changed trouble into *easy results*; drove away the old difficulties of traction plowing and made it the *most profitable*—most satisfactory method of turning soil ever known. The REEVES rides any ground—drops into depressions or passes over hummocks with each bottom holding its proper place in the soil and doing its work accurately.

Pivot Connection

With a REEVES, the engine can be turned freely to right or left with the *plows staying in the ground*—owing to the plow frame's pivot connection with the engine. You can plow a *complete circle* with the REEVES—and do it as well as though you were plowing straight ahead, without putting an over-strain on the engine.

Flexible Frame

Plows are attached to frame in pairs—each plow held in place—*reinforced*—by its companion. If a plow strikes an obstruction that it can cut through, it *cuts* it without interfering with the work of the other plows. If it *can't* cut through it, the plows striking it are released by a spring safety device so that injury to plows or beams is prevented.

Independent Two-Gang Plows

Each pair of REEVES plow bottoms and beams constitutes an *independent two-gang plow*—carried on its own wheel—with its own suction frame—making the *lightest draft* possible. Each pair of plows is connected with frame by pivotal attachment, *permitting plows to rise and fall* according to surface of ground. This also permits a horizontal motion, so corners can be turned without taking plows from ground. Each carrying wheel regulates depth of cut; strong suction compels each plow to cut to proper depth; adjustment at point of beams forces each plow into hardest soil.

Ample Space—Easy Operation

Platform is of ample size—plows are easily raised and lowered by means of coil compression springs. Flexible hitch allows plow to move up and down—high or low hitch can be made according to draw-bar of engine used.

Highest Type of Construction

Every part of the REEVES Engine Gang Plow is of superior material—plow bottom itself is the great EMERSON standard—insuring quality and service of the highest order. Bottoms finished in prairie or old ground pattern. Made with 4, 6, 8, 10, 12, 14 or 16 bottoms.

You can't find an engine gang plow for more satisfactory, greater profit-making service than the REEVES. Write today for free book describing it in detail.

EMERSON BRANTINGHAM IMPLEMENT COMPANY

The Largest Line of Farm Machinery in the world.

ROCKFORD, ILLINOIS, U.S.A.

Tudhope, Anderson & Co., Ltd.

1191 PRINCESS STREET, WINNIPEG, MAN., Canadian Sales Agents.

Regina, Sask. Saskatoon, Sask.
Calgary, Alta. Brandon, Man.
Swift Current, Sask.
Lehrbriere, Alta.
Edmonton, Alta.
Yorkton, Sask.

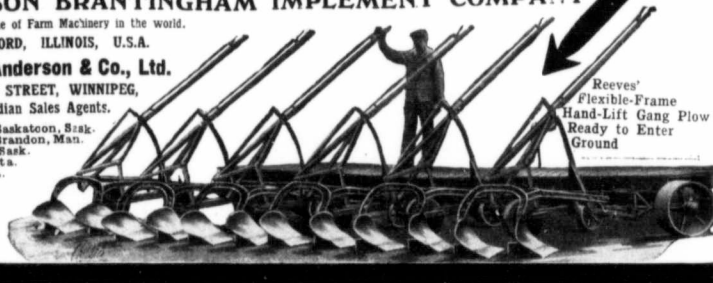

Reeves' Flexible-Frame Hand-Lift Gang Plow Ready to Enter Ground

You saw this advertisement in this magazine. Don't forget to say so when writing.

for this, and, if the engine is large enough for the work, the variation in speed should be so slight that it would hardly be noticed.



Q. Will you tell me how to babbitt the crank pin brasses?

A. You can fasten the babbitt in a crank pin box by drilling the inside full of small holes about one-fourth of an inch in diameter; or another way is to heat box and tin the inside with a soldering copper. Put the box into its place, square the rod by the crank disc, have the key out as far as it will go to allow for as much babbitt as possible. Make two strips of wood to put between the boxes to keep the babbitt from running together. The top strip should be short enough to allow for a

gate to pour the metal; about the thickness of the outside flange of the box is enough to admit the metal so the upper stick can be that much shorter. The upper stick also serves to hold the box and rod up to its place. The top stick should be a little thicker so as to leave a little more space on the top side of the pin to allow a free course for the metal to run. The box should be put in hot so that the solder can unite with the babbitt. This makes a very solid job. The babbitt will wear down to the brass without coming off. When holes are drilled in the box instead of tinning the surface, the box does not have to be heated. The babbitt should be scraped to fit the crank pin, due to the shrinkage of the metal. A babbitted box will wear longer on a crank pin than solid brass one.

Q. How are malleable castings made?

A. The castings are first made of ordinary cast iron, or charcoal iron in the usual way. They are then packed in cast iron boxes with oxide of iron and exposed to a full red heat for from three days to two weeks, according to their size.



Q. I use an ejector to transfer my water from the wagon tank to the engine tank. The ejector heats the water so that the injector will not work the water. What can I do to prevent the water from getting so hot?

A. After the water is started by the ejector turn the steam off until it almost stops working. In other words, use as little steam as possible to do the work. These

machines are made to lift water 15 to 20 feet and the steam pipe and steam jet is large. The ejector should be designed with small steam pipe, and possibly quired to lift the water.



Q. Have read a great deal about babbitting wrist boxings and crosshead boxings, and I want to know just how it is done.

A. Brass is better than babbit for the crosshead end of the connecting rod and babbit is better for the crank pin.



Q. The flywheel on my engine runs out sidewise. I was told that I could get it true by refitting the flywheel key, but am unable to get the key out. Can the wheel be straightened any other way?

A. You can pene the arms to make it true. By this we mean to stretch the surface of one side of the arms, which will bend them. While the engine is running, hold a piece of chalk against each side of the rim of the wheel, thus marking the projecting part of the rim. Now turn the mark on the side next to the boiler down, or at a convenient place so as to get a pry between the boiler and the flywheel at the middle of the chalk mark. This will put the wheel on a strain in the direction in which it should go. Now strike the arms close to the hub, in line with the chalk mark, with a pene hammer, so as to stretch that side of the arms; then go to the other side and pene the other half of the arms in line with the chalk mark on that side. The stretching of the arms on both sides will tend to get the wheel true. Give it a moderate amount the first time and rub the chalk mark off and re-mark, keeping close watch as to the effect it is having. The wheel is so easily bent in this way, that one is liable to give it too much the first time. If it is bent too much it can easily be sprung back with the pry or it can be bent back by peneing on the other side of the arms.



Q. What is the best way to repack the steam chest cover?

2. Is there any law against running an engine without steam gauge or safety valve?

3. What is the best way to re-grind a check valve?

4. How can I regrind a valve globe that has a loose disk?

A. Any kind of packing will do for packing a steam chest cover. The thinner the better, as this packing is not so apt to blow out. A sheet of any kind of heavy paper is a good substitute for regular packing in case of an emergency.

2. Some cities require two safety valves on a boiler. While there may be some places where

there is no specific law on this point, yet there would be a law to punish any one who would destroy life and property, caused by the explosion without these appliances of safety.

3. Fine emery or sand and oil is good to cut the metal and a bit brace is a good thing to turn the valve. In some cases the valve has a slot in the top, so that it can be turned with a screw driver. In other cases the valve can be fastened in a piece of wood and the wood turned by the brace. If there is no room to turn a brace the stick or screw driver may be turned with the hand. This is a little more tiresome, as the power cannot be applied as with a brace.

4. Take the disc off and put it on a stick of wood to grind it, or fasten it on the stem by placing a piece of hard wood between the disc and the end of the stem and then turn the valve by the stem to grind it.



Q. How shall I set or change a pop valve with two hexagon nuts at the top?

2. In a cylinder used six years is it better to buy new rings or have some made large at shop? The cylinder is cast to engine frame, which is fastened to boiler with cap screws and it is almost out of question to remove it here for reborring.

3. Will you give directions for operating a Moore steam pump, and kind of packing to use?

A. You will find on the valve a bolt head and jamb nut. Loosen the nut and screw the bolt down for more pressure and then make tight the jamb nut. About one-sixth of a turn of the bolt will affect the valve five pounds.

2. The use of an engine six years should not wear the cylinder so large that it would necessitate having rings made larger than standard size. In case of a cylinder which is larger than standard size, larger rings may be ordered by making a gauge and sending it to the factory. Cut a piece of one-fourth inch round iron to length that will fit the cylinder. The ends should be rounded over and the piece should be bent so as to just fit the cylinder. This can be sent through the mail and will be more satisfactory than trying to give the exact size by the fraction of an inch.

3. In starting a steam pump turn the exhaust into the atmosphere and open the pet cock on the valve chamber of the pump, to exhaust the air in the pump and suction pipe. After the water flows from the pet cock, close same and then turn the exhaust steam into feed water by the valve provided for the purpose. The water piston packing consists of rubber rings especially prepared for the purpose and furnished by

**START THE NEW YEAR RIGHT BY USING
A BAKER BALANCED VALVE
ON YOUR ENGINE THIS SEASON**

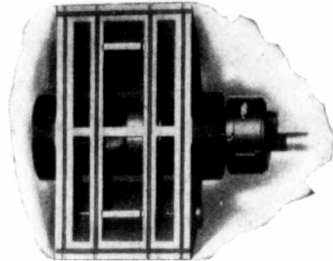

Read the Several Reasons Why

- First**—No more broken Valve Stems and Eccentrics.
- Second**—No more worn Valve Gearing.
- Third**—No more worn Valve Seats.
- Fourth**—No more trouble with Valves in bad water.
- Fifth**—No more trouble reversing engine under full head of steam.
- Sixth**—They pay for themselves in saving of cylinder oil alone.

What They Say About the Baker Balanced Valve

Enclosed please find an order for a Baker Valve for 20-H.P. Case. The one I am using on the 25-H.P. Case is giving perfect satisfaction, saves fuel, oil and water. G. M. Daniels, Plenty, Sask.

Please ship at once another set of Baker Valves for a 25-H.P. Double Reeves, These valves are certainly a great improvement over the D slide valve. Kimble Bros., Bassano, Alta.

Write us at once for prices and particulars

BAKER VALVE COMPANY

100 James Street

Winnipeg, Man.



**Decide Now on Your
1913 Belting Requirements**

You will find the Sawyer Canvas Stitched to be the ideal Farmer's belt. It will stand a few months' rest and come out strong and pliable, or it will stand many years of service.

Write for our Booklet L.

SAWYER BELTING CO., Cleveland, Ohio



Steam or Gas Tractors

Equipped with



give greater efficiency

Equally satisfactory for **STEAM and GAS TRACTORS**

Patent Ball Ranger Speed Changer Supplied on all Genuine Pickering Governors. Will increase speed 50% or more.

The Pickering Governor Co.

PORTLAND

CONN., U.S.A.



You saw this advertisement in this magazine. Don't forget to say so when writing.

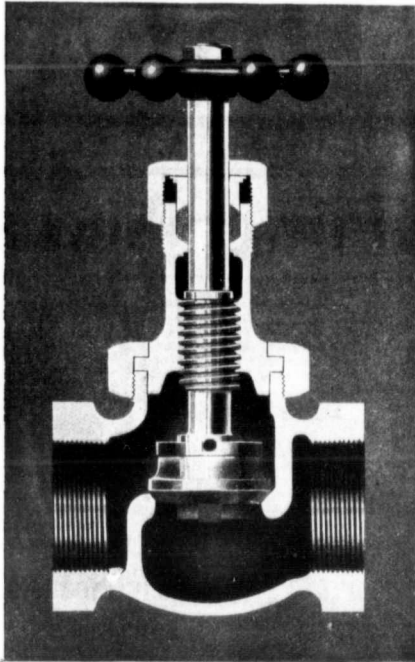

"Something better in valves than you have ever used before."



Regrinding Brass Valves

VIZ:
Globe Angle Cross
AND

Horizontal, Angle, Vertical and Swing Check Valves

GUARANTEED TO STAND A CONSTANT WORKING PRESSURE OF TWO HUNDRED POUNDS

They Have Passed Government-Inspection
for the Provinces of Alberta and Saskatchewan

THEY EMBODY the newest designs and the best mechanical ideas ever employed in valve construction.

THEY WILL GIVE absolute reliable service and dependability under high pressures and severe conditions.

If You Want VALVE Comfort—
Give This Valve a Trial!

WRITE US FOR DESCRIPTIVE
CIRCULAR TODAY

PENBERTHY INJECTOR CO. LIMITED, WINDSOR, ONT.

You saw this advertisement in this magazine. Don't forget to say so when writing.

the pump maker or party which furnished the engine. Any kind of ordinary packing will do for the stuffing boxes.

Q. I have just taken charge of a 12 h.p. engine in which the flues seem to be bent downwards about an inch. Can you tell me the cause of this condition?

2. The engine seems to pull well in the belt and cuts steam correctly running either way, but it will not pull on the road. The liners have nearly all been taken out of the pillow boxes and the pedestal is clear down to the frame. Would the rebabbitting of these blocks have any effect on the pulling power of the engine?

3. Explain how to line up an engine for babbitting, and how to set the valve on an engine of this kind. It has a Woolf reverse gear.

A. The sagging of the flues was undoubtedly due to overheating and this could be caused only by an accumulation of scale around them which prevented the heat from passing readily through into the water. Our advice would be to drain the boiler and see if you can remove the scale from around the tubes.

2. We apprehend that the reason your engine does not pull well on the road is due either to the

faulty setting of the valve or to the wearing down of the main shaft in its bearings to such an extent that the steam distribution is faulty. The Woolf reverse gear, as well as the other valve gears of the radial type, requires close adjustment in order to do the best work. The wearing down of the main shaft a very slight amount will disturb the adjustment a great deal.

3. Our advice would be, in this case, to take the number of the engine and its horse power, and write to the manufacturer for the correct distances between centers for the valve gear. In rebabbitting the Woolf gear it is necessary to know the correct distances between the center of shaft and the center of the block and also the correct length of eccentric rod. These dimensions should be kept on file by the manufacturer for such emergencies as yours.

"Now Harold," said the teacher, "if there were eleven sheep in a field and six jumped the fence, how many would there be left?"

"None," replied Harold.
"Why, there would," said she.
"No, ma'am there wouldn't," persisted he. "You may know arithmetic, but you don't know sheep."

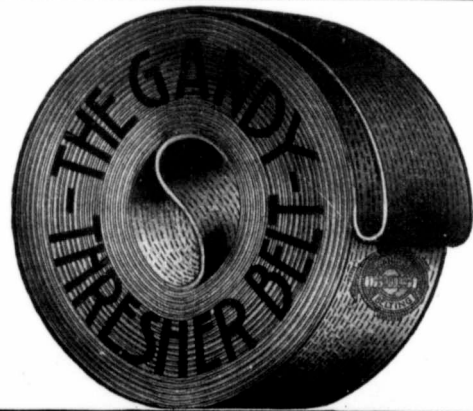

SAVE ON BELTING

Reduce your belt bills. Now is a good time to investigate ways of lessening next year's expenses. 20,000 Thresherman reduce belting expenses to a minimum by adopting

The Gandy Thresher Belt

The Gandy Thresher Belt is not affected by sun, rain, temperature changes, etc., will not stretch or slip, transmits more power, and wears longer. That's why every one of these many satisfied users depend on Gandy and consider it the standard. You can depend on it, too.

Write for samples and booklet today, so you will be able to decide this question before next season reaches you. Write us now on the attached coupon.

The Gandy Belting Company

748 W. Pratt St., Baltimore, Maryland
New York Office: 88-90 Reade Street

Return this Coupon now
Customers send no samples back.
Let's see what you say in C-1 & P-2 1/2.

Name _____
Address _____
Prov. _____

VE
The saves
double
valve.
Man.
Our
ents
invas
ner's
out
vice.
hlo
Drs
GA
ERINC
OF MARY
ESTERED
ing.



Canadian Power, Seed & Soil



Vol. 1, No. 2.

February, 1913

No Matter What Your Power Needs May Be, Ask Rumely To Supply You

Published Monthly by

RUMELY PRODUCTS COMPANY
(INCORPORATED)

La Porte, Indiana, U.S.A.

A Monthly Messenger of Better Farm Methods

In the Winter Prepare for Spring

Big men in business figure with careful precision their work for days ahead. Many can tell today what their program will be six months from now.

The scheme is good. The most successful men—big accomplishers—know that plans must be laid well, long in advance, in order to best take care of their affairs.

Successful farmers and threshermen are becoming more scientific in their business methods every day. They are putting industrial ethics into their work as never before. They are planning more thoroughly and thinking more deeply, in advance, so that when the time comes for action there is no loss or waste of time or money.

By getting ready now, when Springtime comes and the fields are ready for work, opportunity is taken by the forelock. Make out an inventory of your machinery needs. Send for our literature and make your choice now. Ask us the name of the nearest dealer.

Remember, M. Rumely Co. is prepared to equip you with field tractors, portable and stationary engines, threshing machines, grain graders, disc plows, gang plows, harrows, corn cultivators, saw rigs, corn huskers, corn shellers, feed mills, oil and water tanks, cream separators and other implements.

Our Farm Experts are prepared to give you valuable information on power-farming subjects. Send in your questions, addressing "Farm Expert," care of the Advertising Department.

We Acquire Dixon Plant

The farm implement line of the Grand Detour Plow Co., of Dixon, Ill., was recently acquired by Rumely Products Co., and hereafter the famous line of plows, harrows, listers, cultivators and other small farm machinery manufactured by the well-known Dixon firm will be included in the Rumely Power-Farming line.

There is little need for comment on Grand Detour quality. These goods have been on the market for seventy-six years and the name and fame they have won links well with Rumely excellence.

Why The OilPull Works Cheapest

When James A. Secor invented the OilPull Tractor, he put into it an exclusive feature which made it distinctly the cheapest operating gas tractor known. Crude kerosene, unrefined petroleum or distillates, for the first time in history, were made efficient fuels.

The Secor-Higgins carburetor mixes the cheapest oils with water to just the right proportion to make perfect combustion in the cylinder. The automatic principle of feeding is the secret of the OilPull's success. No other tractor manufacturer can use the Secor-Higgins system, as it is securely protected by Rumely patents. Any other tractor will operate on kerosene and crude oils successfully at all temperatures, at all loads.

The OilPull Tractor, for summer or winter, will do your work without expert help, either in the field or for hauling or stationary belt work.

A Trip To The Rumely Factories

In one of the finest equipped trains ever started on tour, consisting of nine sleepers, two compartment cars, two diners and a buffet car, officials of M. Rumely Company, Inc.; Rumely Products Company, Inc., and others to the number of 228, left St. Paul, January 6th, to visit the different Rumely factories and see for themselves just how Rumely Power-Farming Machinery is made.

Aside from the Executives and the Division Sales Managers, all the Branch Managers were in the party, save those located in San Francisco and Los Angeles. There were also many merit and special salesmen. In fact, all salesmen who had sold over \$100,000.00 worth of goods in Canada, \$75,000.00 worth in the Northern Territory, \$50,000.00 worth in the Western Territory and \$35,000.00 worth in the Eastern Territory during the year 1912 were rewarded by having their expenses paid on this magnificent trip.

The first factory visited was that of the North-west Thresher Company, of Stillwater, Minnesota. This company builds the famous GasPull Tractor, and was recently purchased by the Rumely organization. On the day following the Falk Company Works at Milwaukee, Wisconsin, was the goal. Here the OilPull Motor is manufactured. On Wednesday the company visited Dixon, Illinois, the home of the Grand Detour Plow Works, makers of Rumely Engine Gang Plows and other Rumely implements. On Thursday the company spent the day at Battle Creek, surveying the grounds and plant which was formerly the Advance Thresher Company, and, incidentally, the sanitariums and other points of interest in that city. On Friday the Seager Company's factory at Lansing, Michigan, was inspected. Here Rumely-Olds Engines are built. In the same city the plant of the Omega Cream Separator Company is also located, and the party spent part of the day there.

Our New Plow
The Rumely Engine Gang Plow for 1913 is as nearly perfect as it is possible to build.

Rumely Engine Gang Plow
is designed along simple lines, yet has all the strength and durability found in the best plows made. Special safety devices are provided to make the life doubly sure in case of striking rocks, stumps or other obstacles in the soil.

Important Features
There are, and many. Note a few of them in the topic, "For Spring Plowing", on this page.

Rumely Engine Gang Plows
are made in five, six, eight or ten bottom sizes. While especially designed to please these plows may be profitably GasPull and Toehold Tractors, the owners of Rumely OilPull, used with any other style of tractor.

The Rumely 1913 Gang Plow
Our Data Book, No. 338, tells more about them. Ask us the nearest dealer's name.

Rumely Products Company
(INCORPORATED)
Power-Farming Machinery
La Porte :: :: Indiana, U.S.A.

Canadian Branches:
BRANDON, Man. EDMONTON, Alta.
CALGARY, Alta. WINNIPEG, Man.
ESTEVAN, Sask. YORKTON, Sask.
REGINA, Sask. TORONTO, Ont.
SASKATOON, Sask. VANCOUVER, B.C.



Why Rumely Power?
Rumely power is standard. Rumely engines are winners wherever shown in competition. The best engineers procurable direct manufacturing affairs in the Rumely shops. The highest grade materials only are used in the manufacture of Rumely Tractors. The most improved methods are followed; the very latest equipment is used. Neither money nor effort is spared to make Rumely engines best. Because of Rumely reputation, tractors and stationary engines are being shipped by us to even the remote sections of the globe.

Rumely tractors have exclusive features which farmers and threshermen appreciate—features not found in other makes.

Rumely Power-Farming Machinery Covers Almost Every Farm Want
DisC Plows
SepArators
CorN Shellers
SprAyers
WinD Stackers
Stationary Engines
Disc HARrows
CorN Huskers
Soil Packers
Gas and Oil Tractors
Saw Rigs
Steam Engines
CloveR Hullers
Cream Separators
EnginE Guides
WatEr Tanks
GraDers
AlfalfA Hullers
PumpiNG Outfits
ShreDders
HorSe Powers
PlOWs
Feed Grinders
BalLing Presses

From Lansing the train sped directly to Jackson, Michigan, the home of the Watts-Morehouse Company, where are built Rumely-Watts Corn Shellers. On Saturday the company reached Richmond to survey what was formerly known as the Gaar-Scott plant. On Sunday morning, tired but still full of enthusiasm, the Rumely Special steam into La Porte, and home. After resting through the day, the Rumely shops and home offices were visited during the two following days.

Inspiration, good cheer, plenty of music and every comfort were enjoyed by the visitors at each point and with greatly enthused aspirations each man goes back to his work with determination to strive as he never has striven before.

to make 1913 the biggest banner year in Rumely sales history.

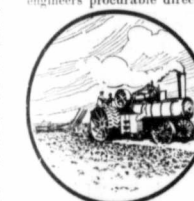

The World's Champion Wheat Grower
When Henry Holmes, with his bushel of Marquette wheat, secured the sweepstakes prize at Lethbridge, at the Dry-Farming Convention held there last October, M. Rumely Company rejoiced. They were glad to have their tractor go to Mr. Holmes because he is a man who tried hard to win, as only hard working farmers strive. Moreover, they were glad to have their tractor go into Canada, into the heart of the dry-farming district.

The OilPull Tractor and Rumely Engine Gang Plows are especially adapted for dry-farming, because the ground is plowed fast and deep by this Rumely outfit. The soil is turned to such a depth that the plant roots have plenty of good feeding space, and the moisture has little chance to evaporate.

Summer fallow with a Rumely Plowing Outfit, then prepare the ground in the following spring for crops. No need to worry about the returns.

Every Rumely OilPull Tractor has as part of its equipment a Dreadnought Guide—a steering device which makes straight furrows, and turns easily at the ends of the field.

Ask us the name of the nearest dealer.
Be sure and read our two-full page ads. in this issue.

For Spring Plowing
Rumely Engine Gang Plows for 1913 are better than they ever were—and that's saying a great deal. We consider them better because they have many new features. For instance, the new beam attachment permits of perfect alignment, so that each bottom will cut the same width and depth furrow at all times. This beam attachment also provides a means for adjusting so that the beams cannot be twisted in sod or rough soil.

The standards are provided with wooden break pins which avoid any possible injury to the standards themselves. Should a rock, stump or other obstruction be encountered, the break pin will give way before the standard and no serious damage result.

While this plow is regularly equipped with stubble bottoms, special bottoms may be had if desired, any of which may be easily attached to the standard—general purpose bottoms, silt bottoms, rod breakers or steel mold-board breakers may be used.

Rumely Engine Gang Plows have a new form of shank casting this year. A roller on each side of this casting reduces friction and makes it possible to raise or lower the bottoms with but little exertion.

The blind quadrant guide makes it easy to drop the plow bottom to a uniform depth without stepping from the platform.

The levers are now made straight and also set higher than formerly; this for the convenience of the plowman in reaching—no stooping or back-breaking work.

The gauge wheel standards are also made longer, so that it is possible to raise the plow bottoms fully six inches from the ground, for convenience and safety in moving from one job to another.

The new Rumely Engine Gang Plow is fully described in our Data Book No. 338, sent free on request. Ask us the name of the nearest dealer.

Rumely Quality
For sixty years Rumely Power-Farming Machinery has been held in high esteem by farmers and threshermen. Why? Because of the honesty of the workmanship and the high standard of all materials which are used in its construction.

The founder, many years ago, built only as honest manufacturers knew how to build. So grew Rumely reputation. Today the Rumely line is greater—far greater than it ever was. Rumely quality accounts for Rumely success.

What The OilPull Did For Mr. Scott
Salvador, Sask., May 21, 1912.
Gentlemen: I purchased one of your model "E" OilPull tractors in the spring of 1911 and started work with it April 18th, 1911. During the spring and summer

I broke 1650 acres, plowed 100 acres of stubble, discd 400 acres four times, and threshed for three weeks, the total running expense for the season's work being \$1900. It cost me to break 90 cents to 95 cents an acre, and I averaged 25 acres a day.

I was breaking in very heavy land and my engine was pulling seven bottoms when many other outfits in the district pulled out entirely because of the very hard soil.

For threshing, the engine does the work very nicely, giving a steady power, in fact, I have never run a steam engine which gave an evenner power on the belt.

My engine earned me \$4,000 net profit last year, after deducting all expenses for running it.

This spring I sowed 1175 acres of crop, pulling four discs, three drills and 10 sections of harrows. It would take 36 horses to pull the load I had on. The cost of putting in this crop amounted to 50 cents an acre.

My engine has done more work than any gas engine in my section of the country—in fact, it is out of their class entirely. When I got the engine my only experience with a gas engine had been watching them run at fairs and riding in one for half a mile once.

I have had a lot of experience threshing, and now own a 40-64 Rumely Ideal Separator, and can say that the Rumely Separator is the most satisfactory separator I have had any experience with. The feeder on the Rumely Separator is very simple to operate, and is as accurate as the governor on a steam engine, and it can never slug the cylinder no matter how you pile the straw in. One of the best points about the separator is its freedom from vibration. Then too, all the parts that may need adjustment or oiling are perfectly accessible on the outside, and it is never necessary to stop the separator in order to oil or adjust it.

Yours truly,
(Signed) W. W. SCOTT.

Profit Makers
Surely you will find profit when you use the OilPull Tractor—profit because of the low cost of running expense—profit because of the saving in hired help bills—profit because you can work day or night, as hard as you please, no matter how hot the weather.

OilPull Tractors
15-30 H.P. 30-60 H.P.

save 10 cents per bushel in growing a bushel of wheat. With this tractor you can plow from 15 to 25 acres a day at a cost of less than 50 cents per acre. Good also for hauling, for running threshing machines, shredding, husking, baling, hulling, road grading—or any other belt work requiring the power of from 30 to 60 horses.

More about them in our Data Book, No. 338.
Ask us the name of the nearest dealer.

Rumely Products Co.
(INCORPORATED)
Power-Farming Machinery
La Porte - - Indiana

Canadian Branches
REGINA, Sask. YORKTON, Sask.
SASKATOON, Sask. TORONTO, Ont.
EDMONTON, Alta. VANCOUVER, B.C.
WINNIPEG, Manitoba

BRANDON, Man. CALGARY, Alberta ESTEVAN, Sask.



Mortgage Lifters
Whether your farm is encumbered or whether it isn't, a GasPull Tractor will bring you money so that you need not worry from debt. Tractor plowing means deeper plowing, and deeper plowing means bigger crops. You will make money by plowing the GasPull way.

Rumely GasPull Tractor
is made in the same sizes as the OilPull Tractor. It is built on simple lines. All working parts are protected from dust and moisture. Important features are its handiness—as easily managed as a team of horses—its low-down construction, and its lightness in weight—only a little more than 1100 pounds.

Send for new Data Book, No. 352.
Ask us the nearest dealer's name.

Rumely Products Co.
(INCORPORATED)
Power-Farming Machinery
La Porte - - Indiana

Canadian Branches
BRANDON, Man. REGINA, Sask. YORKTON, Sask.
CALGARY, Alta. SASKATOON, Sask. TORONTO, Ont.
ESTEVAN, Sask. EDMONTON, Alta. VANCOUVER, B.C.
WINNIPEG, Manitoba





Hog Bristles

It is wise to raise your own breeding sows.

A sow that is raised on concentrated food, without sufficient exercise, will never make a profitable brood sow.

Plan the feeding of the brood sows in such a way that they must walk to get their feed.

Keep them in good flesh and thrifty, but not fat.

Sows will grow sluggish and lazy if allowed to grow too fat, and this condition will work havoc at farrowing time.

Place feeding platforms at some distance from the pens. In stormy weather feed in the pens.

Be sure the pens are free from drafts of cold air.

Keep the beds dry and ample. The more comfortable you keep your hogs, the more profit they will return to you.

Feed the boar for vigor, not for fat, and let exercise enter into his development.

Winter only as many sows as can be given perfect care.

Never feed frozen swill.

Watch the markets; a little depression is always followed by a keen demand.

Breed and feed for the fancy trade.

There is always a premium on choice products.

Use the dish-water for fertilizing purposes, and give the pigs pure, clean water to drink.

Give the hogs every day all the clover hay they will eat.

Sugar beets are a most valuable addition to the pig ration.

If the hogs squeal, find out why. Comfortable hogs never squeal. There is no money in squeals.



Guessing Fatal to Little Pigs

A few years ago I bought two young sows, both bred and due to farrow at a given time, which I afterward learned was a date guessed at by the man who sold them to me.

One snowy morning some weeks before the little pigs were expected, I went to the woodlot

with a bucketful of warm slop, but the sows did not heed my call. Making a search, I found them hidden under a monstrous pile of leaves, with two litters of dead pigs. The farrowing pen under process of construction was of no use that time.

What did I learn? Just this—know the date. Set it down as something important; then be on the ground on that date, not to fuss and cause disturbance, but quietly to watch and right things if anything needs righting. I have saved more money indirectly, through this watchfulness, than by any other one thing in my dealings with hogs.



Wheat and Barley vs. Corn for Hogs

F. G. King, Associate in Animal Husbandry at the Indiana Experiment Station, answering the question: What is the feeding value of wheat and barley for hogs as compared with corn; or, in other words, how many pounds of wheat or barley does it take to produce one ton of pork, and what is the relative value of pork fattened on wheat and barley to that fattened on corn? replies that there is little difference in the feeding value of wheat and corn.

The results of five trials on this subject at different experiment stations show that it requires 469 pounds of corn-meal to make 100 pounds of gain, while it required 463 pounds of wheat-meal, thus showing very little difference in the feeding value between the two. Barley is hardly so good when fed alone for fattening hogs as is corn, but barley should not be fed alone to hogs. When mixed with corn the feeding value of the mixture is as high as that of corn alone; therefore it is a good practice to consider wheat, barley and corn of approximately the same feeding value. Since it is a common practice to consider ten pounds of pork for a bushel of corn, it would require about 200 bushels of wheat, barley or corn to produce a ton of pork.

In regard to the quality of meat furnished, there seems to be little difference between the

Dairy Farming

Is the Bright Spot in Canada's Future!

Soil depletion from constant grain-cropping is the only black cloud in the horizon, but a few

Well-Bred Dairy Cattle
with the aid of a

"MAGNET"
Cream Separator



will do at least two things for you, Mr. Farmer. They will, of themselves, pay you as no other farming proposition will pay you, and incidentally increase the fertility and selling value of your land.

"THE MAGNET" is the "royal road" to success and among all cream separating machinery will just describe the difference between a mere "paying affair" and a **Whacking Big Profit**. Its strong, distinguishing points are its **square gear** that precludes any wobbling, and its **solidly rigid construction**.

Our Slogan is "TO SATISFY"—and we will do it at all costs.

We will prove every point we claim for the superiority of the "Magnet" on your farm—at our expense.

The Petrie Mfg. Co., Ltd.

Head Office and Factory: HAMILTON, ONT.
Winnipeg, Calgary, Regina, Vancouver, Montreal, St. John, N.B.
Edmonton, Alta.

HORSES AT AUCTION

AUCTION Farm Horses PRIVATE
EVERY For Sale SALES
WEDNESDAY DAILY

From 500 to 1000 head of horses constantly on hand, including large Draft Horses, Driving Horses, Delivery Horses, Farm Chunks, Farm Mares, Saddlers and Mules. Every horse hitched and tried before sale. If you want one horse, a team or a car load, come to

BARRETT & ZIMMERMAN'S GREAT MIDWAY HORSE MARKET
Take Mpls. and St. Paul car from either city. **ST. PAUL, MINN.**

International Stock Food

DONT let your horses run down during the winter and get so soft that they will lose flesh badly when you start your spring plowing.

If horses are not worked regularly during the winter, they need the splendid tonic effects of **INTERNATIONAL STOCK FOOD**, to tone up the digestive organs, enable them to get all the good out of their feed, prevent the blood from becoming overheated, and thus ward off disease.

79 "I have fed **INTERNATIONAL STOCK FOOD** for many years. I always have a 25 pound pail standing in my barn. I bought a pair of three year old colts and they were so worked down that my neighbors said I had been beat. When I bought the colts, they weighed 800 lbs. I ploughed 35 acres and they weighed 360—then I harvested 163 acres and threshed and hauled one carload to town, 6 miles, I weighed them again and they weighed 860, and I said "They shall weigh 900 before spring". Now, the Neighbors want to buy them but there's no chance!" J. G. REMPEL.

For sale by dealers everywhere. Our \$1,000.00 Stock Book—sent free when we receive your name and address. **INTERNATIONAL STOCK FOOD CO. LIMITED, TORONTO.**

BLATCHFORD'S CALF MEAL

The complete milk substitute, raises calves without milk, prevents scouring, insures early maturity, raises 3 feed calves at the cost of one. Send for free booklet, how to raise calves cheaply and successfully without milk.

STEELE BRIGGS' SEED COMPANY, WINNIPEG, Man.

meat produced from corn and from wheat; but barley seems to meet with more favor by the more discriminating among the hog raisers, especially when bacon is the kind of meat product desired.

The Horse Constitution in Breeding Stock

In the selection of a stallion it is important to see that the horse has a stout constitution, or his emasculated sons will not be valuable or profitable. This matter of appetite and digestion should, in the stallion, represent a very full and greedy habit, as the sire does not usually do the severe work which impairs the digestion of the gelding. When a colt is added to the list of geldings, his vital forces are thereby materially reduced, his bodily strength is lowered, his digestion is never again so good, and his circulation may yet be healthy, but it is milder. If a gelding be a grass feeder, this troublesome excess would have been more pronounced had he been preserved entire. If a stallion be a light feeder, his stock can never be worthy of stable room. Whatever else be overlooked, at least have the common necessities of a back, body and limbs—and if you must risk something, let it be the frontage. The hinder or propelling part is the motive power, and without it there is no push. Size is an important element, but a leggy horse is highly objectionable.

Not only the stallion, but the brood mare of any type, should have a constitution, the vigor of which can not be doubted. Every good judge of a horse can see at a glance whether she possesses it or not. Be sure there is no hereditary unsoundness, as it is almost certain to ruin the youngsters. Above all, see that there is no roaring in the family. Any small unsoundness in the mare's respiratory organs will not be small in her sons and daughters. There is everything in heredity, even bad habits, such as running away or kicking in harness.

An ill-mannered mare may breed a good, tough, sound youngster, but her filly foals should be broken in very early in life, and before they get strong and resolute. The filly foal of a kicking cart mare should go in the plow team eighteen months, then she is readily managed; but if you wait another year she may give much trouble. Very few geldings kick in any tackle.



We may hide some things; we can never hide our idleness.

J. H. Jowett

CANADIAN STOCK FOOD TONIC

Will improve the Condition of Your Animals



CANADIAN
STOCK FOOD
TONIC
is put up in three
sized packages most
convenient for use;
50 cents and \$1.00 paper
cartons and in 25 lb.
pails at \$3.50 per pail.

Get One Package —Try It!

This tonic Food is not merely recommended for sick animals and fattening hogs. Fed to working horses, milking cattle, or fattening stock of all kinds, Canadian Stock Food Tonic will pay. Canadian Stock Food Tonic will put your animals in a better condition to assimilate and digest their foods. It will tone and strengthen the system of any animal and is guaranteed to cure and prevent diseases.

Helps Working Horses

The rough conditions under which contractors' and builders' teams and delivery horses most frequently work in Western Canada, entails an enormous expense in the up-keep of teams. The use of Canadian Stock Food Tonic and the other remedial preparations of the Canadian Stock Food Company has been worth thousands of dollars to Canadian contractors, builders and manufacturers.

Ask your merchant for Canadian Stock Food Tonic. If he doesn't carry it, write us direct. Allow no substitute. Remember our guarantee is back of every package we manufacture.

Canadian Stock Food Co. Limited

SOLE MANUFACTURERS CALGARY, ALTA.

ALSO MANUFACTURERS OF
Canadian Cough and Fever Mixture Canadian Colic Cure
Canadian Poultry Food Canadian Healing Oil
And Other Remedies.

USED BY C.P.R. CONTRACTORS

S. B. Dunnill, Head Stableman, C.P.R.
Irrigation Project, Bassano, Alta.,
says:

"I can honestly say that after the second day from the date that I administered this wonderful remedy of yours, I have not heard or seen one horse cough. I think your Stock Food and Medicines are the best on the market and a great boon to all horse owners, and will certainly continue to use your preparations."

J. G. Ross & Co., Engineers and General Contractors, Calgary, Alta., say:
"Your Stock Food has given entire satisfaction. We find it has all the good qualities you claim for it."

You saw this advertisement in this magazine. Don't forget to say so when writing.

Handy Things for Farmers to Know

A wrench is a good thing to have along with the plow in the spring. Right now, before you forget, fasten it to the beam with a short strap and buckle. A wire will answer the purpose, too, but is apt to rub the paint off the iron and invite rust.

This is the day of conservation — conservation of forests, soils, waterpowers, everything in nature. Let's take a step forward and place at the very head of the list, conservation of manhood.

Take an old piece of carpet along with you next spring when you go to dig the borers out of apple trees. Kneel on that, in-

stead of the damp ground. May save you a case of rheumatism.

Stretch a small rope across the stall behind a horse that is inclined to pull at the halter. Many a bad case of halter-pulling has been cured in this way.

Do your folks need a good butcher-knife? Hunt up an old flat file and take it to a blacksmith who understands tempering steel, and have him make you one. It will outlast any knife you ever had, if made right.

Because a cultivator is "an old thing," don't cast it off and let it rot and rust down in the fence corner. Wipe it clean, rub a little kerosene oil on its frame

and teeth, and store it away for another season's work.



There is nothing more troublesome to a good mind than to do nothing. For, besides the furtherance of our estate, the mind both delights and betters itself with exercise. There is but this difference, then, between labor and idleness: that labor is a profitable and pleasant trouble, idleness a trouble both unprofitable and comfortless. I will be ever doing something, that either God when He cometh or Satan when he tempteth may find me busy.

Joseph Hall

BALANCED RATIONS FOR POULTRY —WHAT DOES IT MEAN?

BY M. K. BOYER

A BALANCED ration, in poultry diet, means a sufficient amount of carbonaceous material in a mixture to counteract any bad results that might arise where an entirely nitrogenous ration is given, and vice versa.

Too much fat will be produced by a ration rich in carbon. The results of such a diet would give an over-fat condition of the body, and probably death by apoplexy.

On the other hand, an exclusive nitrogenous food would be apt to result in bowel troubles and other disorders.

But, for the thrift and product of the hen—to keep her in a good, healthful condition and produce many eggs—we must use both carbonaceous and nitrogenous feeds. We must properly balance them.

In order that the hen may be able to manufacture eggs, she must be given material that will not only build up the wanting tissues, but will also furnish the right ingredients to make the eggs.

To grow bone and muscle, to keep the bone in healthful condition, to produce feathers and eggs, we must furnish nitrogenous matter (proteids or protein).

To give the hen heat and energy, we use carbonaceous matter (carbohydrates—starches).

The two must be mixed. Fats, to a more or less extent, can be found in every article of food.

Now in making up a ration it is important that it contains food that the fowls will eat readily. Not food that hunger must force them to eat. The ration should have a sufficient quantity of digestible nutrients to furnish the needs of both quick growth and a good supply of eggs. It should be bulky enough so that the digestive secretions may act quickly upon it.

There should not be an excess of indigestible fibre, only to be thrown off by the system, causing a waste of energy.

Professor James E. Rice, says it is not how much a fowl eats, but how much it can digest, that determines the value of a food. Various classes of animals differ in their power to digest the same kinds of food. Foods also vary in their digestibility when used by the same animal. Unfortunately, the proportion of each poultry food which fowls can ordinarily

digest has not yet been determined. Therefore we are obliged to accept the standards of digestibility which are used in compounding rations for other animals as the results of many digestion experiments. (In this case, for cattle.)

It has been found by Professor Wheeler, of the New York Experimental Station, that 500 pounds of live weight of hens in full laying, each hen weighing from three to five pounds (about 100 hens), would require per day, 27.5 pounds of dry matter; 1.5 pounds of ash; 5 pounds of pro-

- No. 2
50 lbs. corn
14 lbs. oats or barley
10 lbs. wheat bran
4 lbs. flour middlings
28 lbs. corn meal
7 lbs. animal meal
10 lbs. cut clover

- No. 3
50 lbs. corn
10 lbs. wheat
28 lbs. cornmeal
2 lbs. flour middlings
10 lbs. hominy
7 lbs. beef scrap
10 lbs. cut clover

- No. 4
50 lbs. corn
10 lbs. wheat
2 lbs. cornmeal
10 lbs. wheat bran
5 lbs. middlings
4 lbs. alfalfa meal
7 lbs. beef scrap

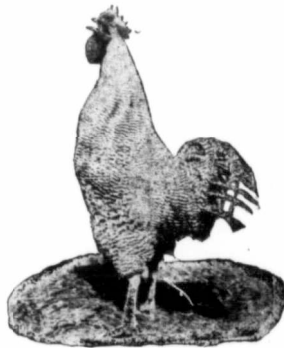

The main method of feeding, at the State Experimental Station, is as follows:

Early in the morning, for each 100 hens, four quarts of screened cracked corn are scattered on the litter, which is six or eight inches deep on the floor. This is not mixed into the litter, for the straw is dry and light and enough of the grain is hidden so the birds commence scratching for it almost immediately. At 10 o'clock they are fed in the same way, two quarts of wheat and two quarts of oats. This is all of the regular feeding that is done.

Along one side of the room is the feed trough, with its slatted front. In it is kept a supply of dry meals mixed together. This dry meal mixture is composed of the following materials: 200 pounds good wheat bran, 100 pounds of cornmeal, 100 pounds of middlings, 100 pounds gluten meal or brewers' grain, 100 pounds linseed meal, and 100 pounds of beef scrap. About five pounds clover hay cut into the half-inch lengths is fed dry daily to each 100 birds in winter.

The average amounts of the materials eaten by each hen during the last year are about as follows:

- Grain and the meal mixture ... 90.0 lbs.
Oyster shell ... 4.0 lbs.
Dry cracked bone ... 2.4 lbs.
Grit ... 2.0 lbs.
Charcoal ... 2.4 lbs.
Clover ... 10.0 lbs.

These materials cost about \$1.45. The hens averaged laying 144 eggs each. In the Maine Station alfalfa and clover are found the most satisfactory green feeds for summer. The free use of rape is believed to make the yolks of the eggs greenish when boiled.

Cater to the market. Tag your shipments. Work for a reputation.

- No. 1
50 lbs. corn
14 lbs. oats or barley
10 lbs. wheat bran
5 lbs. middlings
25 lbs. cornmeal
8 lbs. beef scrap
10 lbs. cut clover

DE LAVAL CREAM SEPARATORS

Don't Delay Buying One a Single Day Longer

If you are selling cream or making butter and have no separator or are using an inferior machine, you are wasting cream every day you delay the purchase of a De Laval Separator.

There can only be two real reasons why you should put off buying a De Laval; either you do not really appreciate how great your loss in dollars and cents actually is, or else you do not believe the De Laval Cream Separator will make the saving claimed for it.

In either case there is one conclusive answer: "Let the De Laval agent in your locality set up a machine for you on your place and see for yourself what the De Laval will do."

You have nothing to risk and a million other cow owners who have made it as test have found they had much to gain.

Don't wait till Spring. Even if you have only two or three cows in milk you can buy a De Laval now and save half its cost by Spring. If you can't conveniently pay cash you can buy a De Laval machine on such liberal terms that it will actually pay for itself.

De Laval Dairy Supply Co. LIMITED
128 James Street, WINNIPEG
173 William St., MONTREAL

Mention this magazine when writing advertisers.

A Success-Making HARROW

BEST for irrigation or dry farming; for summer fallowing and weed killing. The coulters leave the surface mulched so the soil attracts and conserves all the moisture.

ACME cuts, crushes, turns, smooths and levels in one operation

On plowed stubble the trash is left beneath the surface where its fertilizing properties can be made use of. The "ACME" is made in all sizes. Let us send you our catalog.
DUANE H. NASH, Inc., 310 Division Av., Millington, N.J.
John Deere Farm Co., Ltd., Calgary, Alta., 2832
Regina, Sask.,
Winnipeg,
Man.

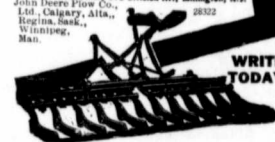

Mention this magazine when writing advertisers

Show your Friends a Copy of this Magazine.

The Whole Truth About Gopher Poison

There are three most common ways of killing gophers. Here is the truth about each method. It will pay you to know these facts. Read them now.



ANTON MICKELSON
The Man Who Makes Kill-Em-Quick

For ten years he was a practical druggist. Farmers came in for a gopher poison. I had none I could guarantee. So I set about to prepare a poison that I could guarantee. I made a ten year study of gophers—their habits, peculiarities, etc. But let me tell you first a few things I have learned about

HERE is what a gopher poison must be, if it is to be classed as a success. First of all, it must have an attractive odor so gophers will be drawn to it—and so they will prefer it to the tender shoots of grain.

Second, it must have a pleasing taste so it will be eaten greedily.

Third, the poison must be deadly, because a sick gopher gets well. For many years I was a druggist. Farmers came in for a gopher poison. I had none I could guarantee. So I set about to prepare a poison that I could guarantee. I made a ten year study of gophers—their habits, peculiarities, etc. But let me tell you first a few things I have learned about

eat a great number of grains or kernels in order that the strychnine may take effect. And that's where the "rub" comes. You see, strychnine is very, very bitter to the taste.

A gopher may eat one or two or three poisoned grains—and stop—just as you would stop eating anything that didn't taste good.

And one, or two or three grains will only give the gopher a pain—that's all. As soon as the pain is over out comes Mr. Gopher with a bigger appetite than ever—and away go your profits.

Even if you could buy strychnine for 12c an ounce, it would still cost you more than Kill-Em-Quick.

Strychnine

It takes a great quantity of water to dissolve or "cut" a small amount of strychnine.

Then, of course, lots of grain must be used to soak up the water. You can easily understand that the amount of poison in each grain is very small—hardly enough to kill a grasshopper.

So it is necessary that a gopher

"Poisoned" Grain

I have heard many reports on gopher poisonings. I am most interested and amused by the reports on so-called "poisoned" grain.

One farmer told me "I fattened the gophers up so they looked like rabbits." And so on. I didn't meet a single farmer who endorsed it. They tried it. They know it is a failure. This year they are all going to use Kill-Em-Quick.

Kill-Em-Quick

It has a very peculiar odor that attracts gophers. It has a very pleasant taste, so the gophers eat it.

And it is so deadly that a single poisoned kernel is enough to kill a gopher "deader than a door nail." Kill-Em-Quick is guaranteed to kill gophers for less than 10 per acre. Here are the figures which show that no other gopher poison compares with Kill-Em-Quick in

Low Price

or efficiency. Mickelson's Kill-Em-Quick contains 154 deadly doses to the ounce. A \$1.25 package contains 26 ounces or over 4,000 deadly doses. 4,000 gophers will eat, destroy and store away about \$400.00 worth of grain. Every pair raises from 20 to 30 young ones every year. Think of it! A box of Kill-Em-Quick selling for \$1.25 is guaranteed to kill 4,000 gophers, saving \$400.00 a year.

Easy to Use

Kill-Em-Quick is as near ready prepared as a good Gopher poison

can be. Mix it with your own clean grain—no poisonous weeds. Soak grain in water over night. Early in the morning, drain water off and mix thoroughly with Kill-Em-Quick—then spread the mixture in your fields early in the morning, when all the gophers are looking for breakfast. For instant use, soak grain in hot water for ten minutes, drain water off and mix with Kill-Em-Quick.



Insist on Kill-Em-Quick

It is absolutely guaranteed to give satisfaction or money will be refunded. See your druggist—be sure to get Kill-Em-Quick—sold only in boxes—never in bulk. Read offer below—and clip coupon now.

A Three Cornered Leather Coin Purse FREE

Made of real leather—in most attractive coin purse you ever saw. In every package of Kill-Em-Quick you will find a coupon. Save two coupons and send with one free, postpaid, the handy, leather coin purse. Get two boxes of Kill-Em-Quick at once, clip the coupon in this "ad" and send us all three.



This coupon, and two coupons from packages of Mickelson's Kill-Em-Quick, entitle you to one Leather Coin Purse Free. Send no money—just this coupon and two coupons from Kill-Em-Quick packages.

MICKELSON-SHAPIRO COMPANY
Dept. C, Winnipeg, Man.

MICKELSON-SHAPIRO CO.
Dept. C, Winnipeg, Man.

Some of the Druggists Who Sell, Recommend and Guarantee Kill-Em-Quick

SASKATCHEWAN

- J. M. Holmes, Aberdeen
- S. C. Kennedy, Abernethy
- Blanced Pharmacy, Alameda
- John T. Mackay, Allan
- J. H. Purley, Alton
- S. J. Donaldson, Arcola
- F. Woodhill & Co., Assiniboia
- T. A. B. Ferris, Balfour
- A. E. Dewar, Balcarres
- Kathleen Bros., Balgonie
- J. D. Nicoll, Battleford
- G. A. McQuig, Benough
- H. W. Fisher, Brandon
- H. O. Langford, Biggar
- F. E. Eley, Blairwood
- G. A. Heron, Bounton
- Christina Wiley, Bredenbury
- Brinsford Drug Store, Brinsford
- W. A. Allingham, Broadview
- W. A. Rife, Brock
- Brownie Drug Store, Brownie
- H. B. Forteous, Carlyle
- W. T. Lockhart, Carleton Place
- J. F. Boylan, Caron
- W. C. Sweet, Croydon
- W. N. Lewis, Coquasset
- A. C. Robertson, Craik
- G. M. Stuart, Cupar
- People's Drug and Book Store, Davidson
- F. J. Fear, Delisle
- Geo. Boyd, Drinkwater
- T. A. B. Ferris, Dufur
- F. E. Livingstone, Dundurn
- F. C. Fowler, Earl Grey
- Elbow Drug & Bk. Co., Elbow
- G. N. Crawford, Elroy
- Hanna, Estero
- C. L. Smith, Estehayak
- R. A. Porter, Eyebrow
- H. C. Cooke, Filmon
- W. J. Hamm, Fleming
- N. H. McDonald, Forget
- F. A. Dunk, Fort Qu'Appelle
- S. I. Cummins, Forward
- H. M. Woodhall, Gadsden
- W. T. O. Welch, Glen Ewan
- Govan Pharmacy, Govan
- D. F. Patterson, Gravel
- G. A. Robertson, Griffin
- H. W. Forsyth, Guernsey
- H. M. Kelley, Gull Lake
- Morrison's Drug Store, Gull Lake
- A. W. Hicks, Halbert
- A. E. Cantelon, Hanley
- Red Cross Drug Hall, Hanley
- Thomas Nuttall, Harwood
- Herbert Drug Store, Herbert
- H. A. McDonald, Heward
- E. T. Walker, Humboldt
- E. P. McCarthy, Indian Head
- A. G. Ordahl, Indian Head
- E. C. Lawrence, Ki-manack
- E. E. Malone, Kelliker
- C. L. Lester, Kerrobert
- M. J. M. McMillen, Kerrobert
- J. W. Lord, Kindersley

- D. C. Hart, Kipling
- Cornelius Reiter, Laird
- G. A. McQuig, Lang
- A. G. Demark, Laseburg
- L. Clark, Langham
- Gordon McKay, Langham
- G. A. Calvert, Lanson
- H. A. Ellis, Lashburn
- J. H. Allan Lumber, Leaside
- J. A. Monkman, Leovrbur
- Lumadon Drug & Bk. Co., Lumadon
- P. L. Teetzel, Lumden
- Lusland Pharmacy, Lusland
- G. A. Macdonald, Maclellin
- Alexander Mitchell, Macoun
- Richard Bryans, Madstone
- R. W. Barclay, Madstone
- E. G. Hewitt, Maple Creek
- C. B. Wilson, Maple Creek
- H. Cochrane, Mayfield
- W. J. Mawhinney, Mamont
- R. G. Combe, Melville
- B. H. Taylor, Melville
- H. E. Koch, Midale
- L. H. Atkinson, Mildred
- M. A. Elliott, Milestone
- E. Bisland, Montmarie
- E. L. Colling, Moose Jaw
- Moore Jaw Drug & Staty Co., Ltd., Moose Jaw
- H. A. Davidson, Moose Jaw
- F. W. Macfarlan, Moose Jaw
- C. B. Nichol, Moosomin
- Walter Pennington, Moosomin
- J. A. Baftam, Morse
- A. E. B. Donovan, Morse
- W. E. Bradley, Mortlach
- H. W. Neils, Neerburn
- R. H. Norris, Nokomis
- Abbott-Wilson Drug Co., North Battleford
- N. T. Brown, North Battleford
- H. W. Wright, North Battleford
- Ogema Drug & Stationery Co., Ogema
- R. J. Barrett, Osage
- G. F. Dainty, Outlook
- A. E. Stewart, Outlook
- F. F. Tripp, Osbow
- Paynton Drug Co., Paynton
- A. L. Keen, Perdue
- F. R. Harvey, Plenty
- N. McMillan, Punnichy
- M. C. Gordon, Qu'Appelle
- Tadison Pharmacy, Tadison
- G. P. C. Redvers, Redvers
- A. Duncah, Regina
- E. A. Jolly, Regina
- H. M. Kelly, Regina
- Regina Trading Co., Regina
- C. H. Marr, Roseworth
- A. A. Holman, Rosiers
- W. A. Hardness, Rouleau
- James Brugh, St. Aldeya
- W. D. Mitchell, Stokrota
- R. T. Crown, Saskatoon
- The Saskatoon Drug & Stationery Co., Saskatoon
- C. H. Stewart, Saskatoon

- F. W. Wakelin, Scott
- G. E. Brown, Scott
- John Carter, Semans
- Sheehy Drug Co., Sheehy
- Kenney and Trenholme, Shellbrook
- V. J. Carlson, Sinitault
- L. W. Brigham, Star City
- E. Hull, Stoughton
- J. H. Cavanagh, Strasbourg
- F. S. Adams, Strasburg
- Sutherland Drug Co., Sutherland
- T. W. Hutchison, Swift Current
- J. P. Rooden, Swift Current
- Swift Current Pharmacy, Swift Current
- W. E. J. Ekina, Theodore
- E. T. Josop, Tuslake
- H. H. Sturty, Tuxford
- Thos. R. Blaine, Tyyan
- A. J. Torrey, Tully
- O. S. Mitchell, Viceroy
- Viceroy Drug and Stationery Co., Viceroy
- A. F. Totke, Vonda
- E. E. Macpherson, Wadena
- J. A. Macdonald, Wapeta
- Thompson's Pharmacy, Wapeta
- E. W. Hixon, Watrous
- The Watrous Drug and Stationery Co., Watrous
- A. W. Staples, Soverlein
- Watson Drug Co., Watson
- T. G. Hayward, Webb
- Weyburn Drug Co., Weyburn
- H. S. Elwin & Co., Weyburn
- O. S. Mitchell, Weyburn
- J. R. Bird & Co., Whitewood
- W. L. Richardson, Wilcox
- A. J. Suter, Wilcox
- E. S. Cody, Wolesley
- R. J. Johannessen, Wynyard
- Wynyard Pharmacy, Wynyard
- G. C. Sweet, Yellow Grass
- W. A. Gorton, Yellow Grass
- H. W. Paddell, Young
- Charles Hudson, Zealandia

ALBERTA

- G. H. Whitmore, Acton
- E. E. Wallin, Barons
- Bassano Pharmacy, Bassano
- J. H. Siles, Bassano
- Joseph C. Paulson, Bow
- A. J. W. Wallace, Bow
- H. G. Hieslow, Biarmore
- Samuel Ferrin, Bowden
- Bow Island Drug Store, Bow Island
- G. B. Mills, Bow Island
- W. W. McNab, Brooks
- The Calgary Drug Co., Calgary
- James Findlay Drug Co., Calgary
- A. M. Wallace, Calgary
- MacFarlane & White, Calgary
- Wendell MacLean, Calgary
- A. M. Wallace, Calgary
- I. Z. Harris, Canora
- A. M. Wallace, Calgary
- Cardston Drug & Bk. Co., Cardston
- Carlstedt Drug Store, Carlstedt

- Thomas Little, Carmangay
- G. E. Brown, Castor
- Castor Drug Co., Castor
- R. L. Dorian, Castor
- A. G. Brown, Cayley
- Tom H. Saul, Chauvin
- O. L. Reinecke, Chauvin
- J. C. Calder, Coronation
- W. J. McNeil, Coronation
- E. L. Huggs, Waskasium
- J. R. McLeod, Ferintosh
- R. J. Watson, Frank
- Gleichen Pharmacy, Gleichen
- A. R. Yates, Gleichen
- G. E. Reinecke, Graman
- Edgington Drug Co., Hardisty
- Alta. Drug & Staty Co., Hardisty
- E. L. Carter, High River
- Austin Francis, High River
- Wm. Geary, Innisfail
- Annie Simpson, Innisfail
- A. W. Bethune, Innisfree
- H. B. Armstrong, Irma
- J. R. Fowler, Irricana
- L. A. Murphy, Killam
- W. Whillans, Kitcoy
- F. W. Ham, Langdon
- Gerow & Patherand, Lethbridge
- J. D. Higginbotham & Co., Lethbridge
- Frank Hedley Drug Co., Lethbridge
- J. D. Allen, Lethbridge
- Kenny & Allen, Lethbridge
- The People's Drug Co., Lethbridge
- Barnes & McNay, Macleod
- A. Young & Co., Macleod
- Nagrath Pharmacy, Magrath
- S. K. Smith, Manville
- E. M. Cawker, Medicine Hat
- Charles S. Pingle, Medicine Hat
- B. J. Fisher, Medicine Hat
- Suggat Bros., Mirror
- M. L. W. Wallace, Milk River
- Nanton Drug Co., Nanton
- P. R. Brown, Okotoks
- Olds Drug Co., Olds
- D. L. McCrex, Pincher Creek
- Edinburg Drug Co., Pincher Creek
- Provost Drug Store, Provost
- W. O. York, Provost
- McHaffee Bros., Raymond
- Geats-Cornett Drug & Bk. Co., Ltd., Red Deer
- Red Deer
- Parker's Drug & Staty Co., Red Deer
- J. L. L. Brown, Rimbey
- H. L. Hunt, St. Albert
- A. Purvis, Sedgewick
- D. T. E. Arns, Sheep Lake
- Ivan Dixon, Staveland
- Dunlap Drug Co., Stettler
- Palace Pharmacy, Stettler
- Stirling Pharmacy, Stirling
- Frank's Pharmacy, Strathmore
- W. E. R. Lambert, Strathmore
- W. A. Miller, Strathmore
- Strome Pharmacy, Strome
- Alberta Drug & Staty Co., Taber
- Marshall Bros., Taber
- C. E. Janieson, Toddb
- Red Cross Pharmacy, Vegreville

- V. & V. Drug & Bk. Co., Vegreville
 - E. J. Kildesheite, Vermillion
 - Fred L. Loue, Vermilion
 - Viking Drug Co., Viking
 - I. C. Jones, Vulcan
 - Red Cross Pharmacy Co., Wainwright
 - R. H. Chambers, Wainwright
 - S. Cope, Warner
 - H. L. Huggs, Waskasium
 - H. K. Galway, Waskasium
- ### MANITOBA
- W. S. Walker, Alexander
 - W. S. Walker, Baldur
 - A. G. Langkan, Binschard
 - The Birnie Drug Co., Birnie
 - L. J. Carter, Bissett
 - Central Drug Hall, Boissevain
 - D. E. Clement, Brandon
 - Spearin & Co., Carberry
 - D. R. Black, Cartwright
 - F. H. Fraser, Chandall
 - V. Allen, Darlingford
 - Alairon's Drug Store, Dauphin
 - Cowan & Hays, Deloraine
 - C. F. Hasselfield, Deloraine
 - John Mounier, Elkhorn
 - G. N. Maynes, Foxwarren
 - J. T. Green, Gilbert Plains
 - N. B. Henry, Glenora
 - G. D. Shortreed, Grand View
 - B. R. McLaughlin, Hamiota
 - E. W. Bailey, Hartney
 - F. Woodhill & Co., Hartney
 - F. E. Campbell, Holland
 - P. D. Evans, Killarney
 - C. C. Parker, Manton
 - M. L. W. Wallace, Mathew
 - J. W. Hewitt, Melita
 - M. L. W. Wallace, Miami
 - R. K. Chalmers, Minnoka
 - H. T. Butchart, Minnedosa
 - The Minnos Pharmacy, Minnedosa
 - The Bruce & Han. Co., Morden
 - J. V. Collins & Co., Morden
 - R. C. T. Collins, Morris
 - M. H. Hamilton, Neepawa
 - R. Ripper, Neudale
 - S. J. Kirk, Oak River
 - Plum & Co., Pilot Mound
 - R. T. Hoskins, Rapid City
 - Reston Drug Co., Reston
 - Argue & Co., Roland
 - William Ledingham, Russell
 - D. M. Young, Selkirk
 - D. M. Young, Selkirk
 - S. J. Burnett, Somerset
 - Morton & Co., Souris
 - Sherrin & Co., Souris
 - L. W. Bringham, Star City
 - H. A. Patterson, Strathair
 - R. L. Davidson, Swan Lake
 - F. H. Agnew & Co., Swan Lake
 - Geo. Graham, Treherne
 - S. J. Hall, Virden
 - Hughton & Son, Virden
 - W. E. Shields, Waskada

Farming a Half Section of Land

Continued from page 13

Cash Account
Dr.

To one shoe drill	\$ 120.00
To barb wire	6.50
To hired man's wages	105.00
To mower	50.00
To horse-rake	35.00
To cost of granary	350.00
To twine	31.50
To binder	100.00
To threshing bill	204.00
To neighbor's bill	15.00
To payment on place	616.00
To taxes	52.00
To sundries	100.00
To balance on hand	304.00
Total	\$2089.00

Cr.	
By cash on hand	\$ 811.00
By 1 carload oats	648.00
By 1 carload oats	630.00
Total	\$2089.00

Having balanced up his books he found that they credited him with \$304.

Third Year

Time was gradually wearing on and it was near seeding time again; but before seeding started he had his seed and feed grain to clean. The third year found him quite a lot of work to do in the spring and during the summer. So he bought another team of mares and a set of heavy harness together with a walking gang plow. He hired a man the third year for eight months at \$30 a month beginning on the 1st of April. After he was done seeding he hauled out (1,500 bushels of old oats at 40 cents per bushel). Having got his oats drawn out he was ready to start his barn which was a frame 30 feet x 50 feet. As he intended to put a stone foundation under the barn, he would require a lot of stones, so that he started the hired man hauling stone, while he himself drew some of the lumber home, so that he would have no delay when building operations commenced. He hired a carpenter to help him, so after the stone work was done he commenced the framework. While he and the carpenter were working at it, the hired man was hauling the remainder of the lumber and gave them any help that they should require. After the barn was completed, the hired man started breaking and broke 35 acres. When finished breaking they cleaned up around the building. Then the hired man started discing.

During the summer he found it necessary to have a buggy. So he bought a buggy and a set of single driving harness. As some of his horses were idle nearly all the time it was not necessary for him to buy a driver. When he had finished building he found it was getting near haying time, so he started haying putting it in his

new barn, so that it would be free from wet weather. After haying it was time for harvest, so he went to town for twine. When harvest started he was kept pretty busy, as there was just himself and the hired man to take his bumper crop off. When finished cutting, he built a portable granary 12 feet by 16 feet to hold his grain and for convenience in threshing time. This year he had too much crop to stack, so he got it threshed out of the stook. He hired with the outfit himself and two teams for \$6.00 a day, and the thresher found a man to drive one of his teams. His crop turned out well, averaging 60 bushels per acre or 170x60=10,200 bushels in all, at 3½ cents per bushel for threshing it. His neighbor boarded the men for him while threshing. He worked with the machine 24 days, making \$144. After this his man left him so he plowed until the ground froze up. He found he had quite a number of bills to pay and he had to haul out some grain to meet their requirements. He sold (4,000 bushels of grain at 35 cents per bushel) bringing a nice sum of \$1,400. It was now around to winter time again, so he hired a man to look after his stock during the winter while he was back in camp getting out lumber for a house the following year. He stayed in camp until about the middle of February, then he hauled his lumber home. While in camp he came home Saturday nights to see that everything was alright. This found him at the first of March, so he paid his third payment on place and his taxes. He now balanced up his books to see how his finances were.

Cash Payment
Dr.

To team of mares	\$ 500.00
To harness	37.00
To plow	37.00
To cost of barn	600.00
To buggy and harness	120.00
To twine	54.00
To threshing	357.00
To hired man's wages	240.00
To payment on farm	592.00
To P. granary	60.00
To taxes	61.00
To man's wages	60.00
To sundries	175.00
To balance on hand	137.00
Total	\$3048.00

Cr.	
By cash on hand	\$ 304.00
By 1 carload oats	600.00
By money earned	144.00
By 1 carload oats	600.00
By 4000 bus. oats	1400.00
Total	\$3048.00

After balancing up his books he found that they credited him with \$137 in cash and 5,600 bushels of grain on hand. At the end of the third year he took an inventory of everything to find what he was worth.

Inventory

Land	cost	\$4,800	is worth today	\$9,400	increase	\$4,600
Horses	cost	1,500	is worth today	2,000	increase	500
Feed	cost		is worth today	140	increase	500
Machinery	cost	7,700	is worth today	700	increase	
Buildings	cost	1,100	is worth today	1,100	increase	
Total	cost	8,100	is worth today	13,340	increase	5,240

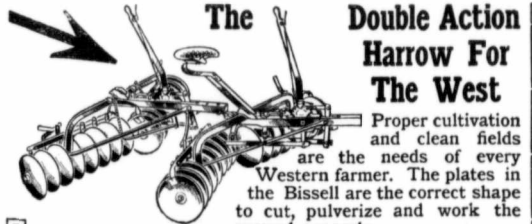

The Double Action Harrow For The West

Proper cultivation and clean fields are the needs of every Western farmer. The plates in the Bissell are the correct shape to cut, pulverize and work the ground properly.

BISSELL DISK HARROWS

Simplicity of construction, every part built for business, proper balance and the knack to get right down to perfect work make the 'Bissell' ideal for Western farms. These double action harrows have one disk out-throw, the other in-throw, giving two full width cuts. Connect up 4, 6 or 8 harrows with engine power for a large complete Disking Outfit. Write Dept. L.

Manufactured exclusively by

T. E. BISSELL COMPANY, LTD., ELORA, ONT.

Write to any of the

Jno. Deere Plow Company's Branch Houses

You saw this advertisement in this magazine. Don't forget to say so when writing.



What is a Good Roof?

Is it something like this? A roof that can't catch fire from burning embers. A roof that will wear as long as good cedar shingles used to wear. A roof that isn't going to be an expense for repairs. You get everything that makes a high-grade roof when you buy

NEPONSET PAROID ROOFING

Over 5,000,000 square feet have been used in the Panama Canal work. Leading Railway Systems are also big users, including the Canadian Pacific. Bought everywhere by farmers for high-grade barns as the best roofing value on the market. A big warehouse roofed in 1896 was torn down last summer with the NEPONSET Paroid roof in good condition. This is the roofing with a record. Make sure that you get it. Sold only by regularly authorized NEPONSET dealers, leading hardware and lumber merchants.

Send for Blue Print Barn Plans—FREE

You will like these plans as expressing the Canadian idea of a real barn.

NEPONSET Roofings are made in Canada.

F. W. BIRD & SON (INC.) 429 Heintzman Bldg., Hamilton, Ont.
Winnipeg St. John, N. B. Vancouver, B. C.

NEPONSET Prostate Roofing makes a handsome red or green roof for houses.

You saw this advertisement in this magazine. Don't forget to say so when writing.

Wall Plaster

Patent Hardwall Plasters (the "Empire" Brands) manufactured from Gypsum will give results not to be obtained by any other plastering material or so called plaster substitutes.

Plaster Board—the fireproof plaster lath and sound deadner

THE MANITOBA GYPSUM COMPANY, LIMITED

WINNIPEG, MAN.

You saw this advertisement in this magazine. Don't forget to say so when writing.

He found after everything was straightened up, he had an increase of \$5,240 on land and stock, with \$137 cash, and 5,600 bushels of grain yet to sell. He has still to pay on his land \$2,800. This goes to show what farming is in the West, and what a young fellow may accomplish if he is interested along farming lines. Although he started with a little capital it does not go to say that a man having no capital at all could not do the same, but it would take him a longer time to do it. This also helps to prove what can be done on a farm and if properly handled gives the quickest returns for the money invested.

A Record in Tire Service

News comes to hand of what a record in automobile tire endurance must surely be a record performance—at any rate as far as Canada is concerned.

The car in question—a Norwalk "6"—was delivered in the Dominion on the 27th of June last, and up to the present (a period of six months) has done fifteen thousand miles over Canadian roads.

The outstanding and extraordinary feature, however, is that the first thirteen thousand miles were accomplished with the same air in all four Goodyear Tires—a record which in all probability would have been maintained for the full 15,000 miles, only it became necessary on account of muddy roads to replace the plain tires of the rear wheels with Goodyear Non-skids.

The front tires today contain the same air as at the commencement of this extraordinary mileage, and the two non-skids have not been deflated once during the 2,000 miles subsequent to the shift.

An endurance trip was also made, namely, 386 miles continuous travel to Quebec by way of Ottawa. The distance was covered in the wonderful time of 17 hours, over roads sodden by continuous October rains. Motoring men will appreciate the Brockville to Prescott portion of the trip—the 12½ miles being covered in 15 minutes, including two stops to pay tolls.



Huber Company Open Branch In Canada

The Huber Manufacturing Company have opened a branch in Western Canada at the Corner of Logan and Arlington Streets. This concern is one of the oldest firms in the Threshing and Power Farming Machinery business.

The business will be in charge of N. A. Neller-moe, who is well



"Here is the New Way to Get a Better Barn at Lower Cost"

"I have seen an astonishing thing happen in Canada, the land of lumbering. This is it. Lumber is getting so poor and costly, and labor so high priced, that you actually save money by using corrugated iron (galvanized) for your barn walls, and metal shingle for the roof. This is the new way to build barns."

"I Want to tell You about the New 'George' Shingle for Barns"

"YOU can now buy my big 'George' Shingle. It makes a quick-laid metal roof that is good for 100 years, is easy to lay, and non-corroding. It makes a perfect roof for any building of large size. It is lightning and fire-proof; it needs no skilled labor; each shingle locks into the others around. 'Use it. Lay it, and your barn will not leak. Lay it, and you save days of wages against cedar shingle. Lay it, and you are done with repairs or further attention. Your barn is perfect.'"

"I want to save you money. My roof for barns is the most economical made. It is sold all over the world in 16 x 20 inch size, but from now on, you can buy it in 'George' Size, 24 x 24 inches to a single shingle, as well. Write my nearest branch and learn about why I made it."

"Remember, I make metal culvert, man-gers and troughs, portable buildings and granaries in metal, metal tile, metal walls, ceiling and siding for farm houses, etc. Write me if you need any of these things."

SEND FOR MY NEW PEDLAR BOOK, FREE

"I have written a little book telling how a modern barn is built, and showing it, step by step, in pictures. It uses my galvanized, corrugated iron and 'George' Shingle, instead of wood. Send for the book to my nearest branch. It may save you thousands of dollars. Write to-day, friends, and read about a barn that saves cost."

331

The Pedlar People Limited

TORONTO 113 Bay Street MONTREAL 321-3 Craig St. ST. JOHN, N.B. 42-46 Pr. William St. OTTAWA 432 Sussex St. PORT ARTHUR 45 Cumberland St.
 MOOSE JAW WINNIPEG MEDICINE HAT LONDON EDMONTON HALIFAX
 202 Fairford St. 76 Lombard St. -- Toronto St. 86 King St. 563 3rd St. W. 16 Prince St.
 SYDNEY SASKATOON CALGARY CHATHAM QUEBEC
 194-208 George St. Box 1645 Rm. 7, Crown Block 200 King St. W. 127 Rue du Pont
 V. NICOVER VICTORIA LETHBRIDGE OSHAWA, CAN.
 108 Alexander St. 434 Kingston St. 1262 1st. Ave. So.

Address nearest Office for "George Shingle," Book No. 166

You saw this advertisement in this magazine. Don't forget to say so when writing.



known to the Western Canadian implement trade. Mr. Neller-moe started business some eighteen years ago at Sacred Heart, selling farm implements. These farm implements included the Huber line. In 1904 he came to Winnipeg, Canada, at the time of the organization of Haug Bros. & Neller-moe, a name that is very familiar to our readers, and for the past nine years has been connected with that firm.

As Canadian manager for the Huber line, Mr. Neller-moe wishes to convey to his friends in the implement business his most hearty appreciation of their co-operation in the past, and at the same time solicit their good will in his present business.



Mr. N. A. Neller-moe.

The Huber line is well and favorably known, and is worthy of the close investigation of the intending power farming purchaser.

"So you heard the bullet whiz past you?" asked the lawyer of the darkey.
 "Yes, sah, heard it twict."
 "How's that?"
 "Heard it whiz when it passed me, and heard it again when I passed it."

"And you really think, doctor, that you must perform the operation today?"
 "Oh, yes. There may be no necessity for it tomorrow."

Farmer Up-to-Date - Farmer Good Intention

Their Farms adjoin. Both of these Farmers live in your neighborhood. You know them and they know you. Are you one of them? If so, we sincerely hope you are the right one.

FEBRUARY 1913

FARMER UP-TO-DATE

Father: That is an extraordinary state of affairs we are allowing the livestock market to drift into. Have just been reading the report of the Canadian Bank of Commerce for last year. They give a review of business conditions all over the country during 1912 and the figures covering the cattle exports are certainly staggering—unfortunately on the wrong side. Out of six years' returns we touched our high-water mark with 67,000 head in 1909 but since then the shipments have rapidly dropped till I find we only exported 5,000 in 1912. And this, mind you, in the face of the fact that the price of the highest grade beef cattle on the Winnipeg market has risen from about 3¼ cents on the hoof to 6¼ cents. Of course this is due to the shrinkage in the ranching country but it has set me thinking of ourselves.



Henry: These are remarkable figures for a "prosperous" country, father, and I've no doubt they are correct. I think a mistake has been made in the breaking up of a lot of the ranching districts in Alberta and Southern Saskatchewan into small farms. It would be all right if these were ever likely to make good farming territory, but from what Bill Jones tells me (and he knows the country thoroughly) a lot of that land is only fit for a ranching proposition. As the cattle problem comes back to ourselves, I do think we could handle a few more milkers to advantage and I'll never give up the idea of keeping a few well-bred sheep (Leicesters, for choice). I think you ought to see George Allison and get him to fix you up with a few this spring. George has made them a good paying line and they are grand weed killers.



Mother: I like to hear you talking of sheep, Charlie. I never see them on a bit of land anywhere or hear them bleating in the fair grounds but I wish we had a few ourselves around the place. I have often intended to speak to you about them, Dad, but I suppose we are just like a lot of our neighbors. We have set out on a beaten track and get so busy we forget about a lot of things we would like or ought to have until we are compelled to get them. I know there is far too much grain-cropping year in and year out and everybody seems to admit it when you speak to them about it. Why is it that the country on the whole is so slow to go in really for mixed farming? I suppose it's sheer laziness in a lot of cases, or indifference as in our own case, when things are running smoothly.



John's Weekly Letter: Things are humming this year at Manitoba Agricultural College. We are "full up"—something like 300 male students and about 60 farmers' daughters going in for domestic science and dairy work, etc. We have had a special "free for all" poultry course which has been made very interesting, besides handling the subject more thoroughly than it is usually dealt with as regards killing and dressing the poultry for marketing. I had no idea it was to be such a fine and comprehensive affair, else I should have had mother up to Winnipeg for a day or two. But I understand this is just a beginning to a series of demonstrations and experiment stations in handling poultry that will soon be established at convenient points in the Province, so she will have her opportunity without travelling far afield.

FARMER GOOD INTENTION

Father (after finishing a new poultry house he had intended to put up five years ago): Well, that's that job done anyhow! I hope it will ease your mind, mother, and save you a bit of work. I do assure you I have felt ashamed many a day—especially in the extreme weather—when I've seen you feeding the chickens and patching up fresh holes the last night's wind had opened up. And maybe we'll begin to get some better results from the hens, for I am free to confess that if I had been a hen myself I would never have laid an egg in that ramshackle place. I have enough lumber left to do as much for the stable and while I am on the run you had better look around and see if there's anything in the house needs patching up.



Mother: That's the best bit of work you have done for me or yourself for many a day, John. I thank you, and as you've made a start to mend things, I hope we'll be able to keep it up and see everything in our life on the farm mending. I think the only way for any one to get out of a muddle and into a clear course is to take one thing at a time and finish it. Now you've made a grand start. I don't want to "rush" you, but strike while the iron is hot. Move while the spirit moves and, for instance, don't allow the patching up of the stable to remain among the things you "intend" to do. If it will encourage you to go ahead, I can leave some of my housework for a couple of days and help you on the stable while the weather permits.



Charles: You'll do nothing of the sort, mother. Yours is not a job for the outside in this weather. I'll give father all the help he wants on the stable whatever I have to let go to get at it. I'll help him with the last ounce of my ability if he will only keep going and let me chip in. There's a lot else to be done, I know, but as you say, mother, we must tackle and finish one thing at a time. If father has any lumber left, I wish he would let me have it and if I have to put a bit of my own money into the pot I'll buy what more is necessary to fix up a really efficient hog pen. Our hogs are like the hens. They have been having a rough time of it and the treatment is beginning to tell on them. We can make or lose an awful lot on hogs and I'm persuaded the game is entirely in our own hands.



Bob: I have just been to Brydon's and I want to tell you that they have got the short cut right enough to good farming at the least outlay. The old man started a time table some ten years ago and he has stuck to it religiously since then. Up till that point he had been perishing his land but he got woke up by one of the professors (Saunders I think it was) from the experimental farm at Ottawa. He showed me his rotation chart and the beauty of it is he hasn't left it on paper. He assures me that he hasn't missed one feature in it any one season. Says you can't do any good by trying all sorts of things at odd times in the way of experiments. The thing is to be decided as to what is the right thing to do under your circumstances—to persevere with it and give it a chance to mature.

50 Sold in 1911—500 in 1912 One Thousand in Line For 1913

We Can Save You a Big Discount on the Cost of Machine

If you will make your inquiry NOW instead of just within a week or two of harvest. We are so pressed with orders and prospective orders, we must make our season's arrangements AT ONCE in order to satisfy every customer as to delivery. You are not committed in any way if you write for full details.



This record has been made solely because the men who used the **Stewart Sheaf Loader** in 1911 and 1912 did find that it took the place of the number of men and bundle teams we said it would, at a time when hired help was next to impossible to obtain, and when possible, could only be got at prohibitive cost.

You can see or correspond with every one of those men. Let us give you their names and location, if you don't already know a neighbor who has done his harvest work with a

Stewart Sheaf Loader

The STEWART SHEAF LOADER

Will positively rid you of all the worry of harvest from the time the crop has been cut. It will handle any kind of grain in any condition. It will do it better than human hands could do it and save in hard cash from \$25.00 a day upwards.

Write at once to the
STEWART SHEAF LOADER COMPANY Ltd., 804 Trust & Loan Bldg., WINNIPEG

You saw this advertisement in this magazine. Don't forget to say so when writing.

Milling and Baking Tests of Prize Wheat

The Department of Agricultural Extension of the University of Saskatchewan has recently received from R. Harcourt, B.S.A., Professor of Chemistry at the Ontario Agricultural College at Guelph, the results of a milling and baking test made on the prize-winning exhibits of wheat shown at the last Provincial Seed Fair which comprised eight samples of Red Fife, eight samples of the new Marquis wheat, and four samples of other varieties. The outstanding feature of the whole of the samples submitted was that of a sample of White Fife.

A sample of the Marquis wheat was chosen as a standard with which the others were compared regardless of class; this sample analyzed as follows: Gluten 39.83, Absorption 69.4, Yield of Bread 100.0, Size of Loaf 100.0, Quality of Loaf 100.0, Color 100.0, Texture 100.0, Appearance 100.0, Average Value 100.0. Per Cent of Flour 62.0. The sample of White Fife referred to above gave the following results: Gluten 39.70, Absorption 73.7, Yield of Bread 98.5, Size of Loaf 103.0, Color 100.0, Texture 100.0, Appearance 104.0, Average Value 101.0, Per Cent Flour 62.3, which marked it

'WAY BELOW ZERO

That's the Time You'll Appreciate a

Manitoba Engine.

Men who own **MANITOBA** Engines write us that they have run when it was 35, 40 and even 52 below zero, and they all say it ran just as well as under more favorable conditions.

That's what we want to hear, although we know it beforehand. We built the **MANITOBA** Engine right here in the West, with a full knowledge of Western conditions and requirements.

Without going into all the details of **MANITOBA** Engine construction (which we handle very fully in our catalogue) we can state that cost of building is disregarded where it's a question of efficiency. We are putting more money into our engines all the time, and our output doubles from year to year. Making in such quantities, we can put in the best, without increasing the price.

Our catalogue is an eye-opener for the engine buyer. Let us send you a copy by return mail. A post card will do.

WE MANUFACTURE Gasoline Engines, 14 to 25 h.p. Wood and Iron Pumps Pumping and Power Wind-
Grain Grinders, 6 to 12 inch Wood Saws, all sizes mills, 6 to 16 feet.

"Made in the West for Western Needs."

MANITOBA ENGINES LIMITED

(Formerly The Manitoba Windmill and Pump Co., Limited)
BRANDON, MAN. CALGARY, ALTA.

You saw this advertisement in this magazine. Don't forget to say so when writing.

as the best of the samples submitted. The Marquis wheat as a whole scored particularly high in the matter of average value, no one sample receiving less than 95, the average for the whole being 95.7,

as against 91.6 in the case of the Red Fife, and 90.7 of the other varieties. The Red Fife gained the highest points in both percentage of flour and also in gluten, the averages being: Flour 62.12, Gluten 38.62. Marquis, Flour 60.87,

Gluten 36.27. Other varieties: Flour 59.75, Gluten 35.77. Professor Harcourt urged that too much value be not given to the figures denoting flour percentage owing to possible inaccuracy of milling with small mill.

Banker's Review of 1912

The Canadian Bank of Commerce has just issued in book form a review of business conditions during the year 1912. The compilation has been made by the various officers in charge of the bank's interests at the points under review and is a thoroughly comprehensive and authoritative resume of the year's progress.

Dealing with the provinces of Manitoba, Saskatchewan and Alberta, the report is careful to point out the regrettable depreciation in live-stock production and in this connection quotes the impressive figures of six years' cattle exports from the ranching province of Alberta. In 1907, 43,000 head were shipped. This rose to 62,000 in 1908 and 67,000 in 1909, but begins to drop to 52,000 in 1910, till it comes down to the alarming figures of 11,000 in 1911 and 5,000 in 1912.

The statement is made that "it has become clear that a serious mistake was made in putting no restrictions on the settlement of ranching lands. Large areas better suited to ranching than farming have been rendered useless for ranching by a scattered settlement, and a Government Commission has now been appointed to enquire into and report on the advisability of setting apart certain tracts of land for the encouragement of ranching and grazing in southern Saskatchewan and Alberta."

The report continues: "If much is to be accomplished in this direction, however, it will be necessary for the Government to make a considerable appropriation to buy out settlers in districts best suited for ranching and move them to other districts. How deplorable a situation has been created in the cattle-raising industry of the West will be understood when it is stated, on excellent authority, that so great is the shortage of cattle in the hands of ranchers and farmers combined that contracts have already been made under which dressed beef from Australia and New Zealand will be delivered at Vancouver in March and April for Western packing houses."

"Mixed Farming" is strongly inculcated, and the Bank's observations in this connection are of special significance at this time: "By far the larger portion of the three western provinces is admirably adapted for mixed farming, and it is a matter of great importance that the adoption of such methods should proceed much more rapidly than is at present the case. It is gratifying to find that this year over a large portion of Manitoba and Alberta and in

Continued on page 61

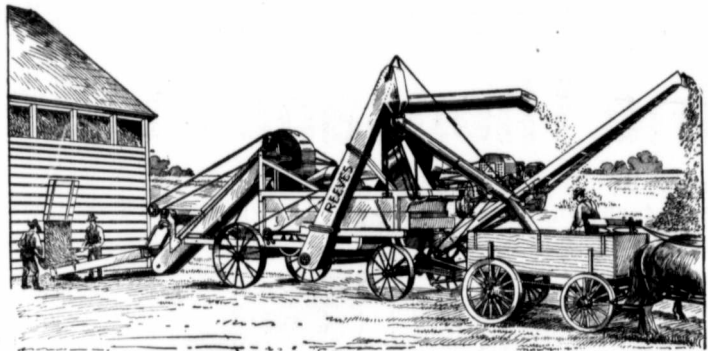

Shell Your Corn and Your Neighbor's—Too!

YOU can do both easily and quickly with a Reeves Corn Sheller. It shells fast and clean—has a larger capacity than any other. With the Reeves there is no wasted corn, no dusty and broken cobs. All the dust and husks are delivered through an adjustable blower away from the sheller.

With the Reeves you are certain of quick returns this season, and you are prepared for many to come.

Reeves Corn Sheller

BUILT TO LAST

On the Reeves Sheller the heavy shafting, gears, sprocket wheels and chain provide strength and prevent costly breakage. The gears run in a dust-proof, oil-tight case. The large cleaning shoe and blast fan, chilled-face cylinder and light draft combine to make the Reeves Corn Sheller durable and profitable. Let us send you our latest corn sheller catalog. Write today.

Emerson-Brantingham Implement Co.

1199 Princess St.

(Incorporated)

Winnipeg, Man.

Largest line of farm machinery in the World: Plows, Harrows, Pulverizers, Listers, Spreaders, Planters, Drills, Cultivators, Mowers, Hay Tools, Baling Presses, Corn Shellers, Gas Engines, Farm Tractors, Steam Traction Engines, Threshing Machines, Road Rollers, Wagons, Vehicles.

30158

Water Scarcity Booms Business for Well Drillers

Enormous increase in immigration, scarcity of pure water and alarming spread of TYPHOID FEVER are booming the well-drilling business. Entire populations demand pure well water.

Well drillers are making from \$25.00 to \$50.00 a day clear profit the year around. Magnificent money-making possibilities for live men everywhere who want to work—men who have a reasonable amount of money to invest in machinery—men who can grasp the exceptional opportunity for engaging in this business NOW—a business VITAL to the country's prosperity and growth.

Immigration Compels Immediate Action!

Hundreds of thousands of families are settling throughout Canada, and every homestead requires a pure supply of fresh water. Creeks, lakes, ponds and shallow wells, now contaminated in every locality, are being condemned by health authorities. And the drilled well is the people's only alternative. Today, there is ten times more drilling to be done than men to do it. Enter this profitable field, simplify the work with

Armstrong Well-Drilling Machinery

Built for Service Since 1867—Cuts the Cost—Trebles the Profits

Armstrong Well-Drilling Machinery affords you the quickest and easiest way to turn the Canadian water scarcity into profits. It does more work at less expense than any other drilling machinery in existence.

By actual test **Armstrong** machines average 92 feet per day in soft earth—a machine for any depth, every rock, using 6½ gallons of fuel on work where other machines average only 60 feet on 12 gallons. **Armstrong** gives 4¢ per cent more efficiency at 2¢ per cent less fuel.



For nearly half a century **Armstrong Machinery** has been noted for its unequalled durability; also for its simplicity of construction and operation. Our patented Internal Compensating Band Wheel Clutch—which does away with lost motion—is one of the greatest improvements ever made in well-drilling designs. This clutch and our improved friction hoists do away with all attachments, balance wheels, cast brakes, cams, bumpers, treadle levers, bumper sills, eccentric rollers, chains, springs, sprockets and ratchetets. Produce ideal elliptic drilling motion with absolute minimum friction, eliminate expensive repairs and delays. Only one gear and pinion. We make gasoline and steam outfits—traction and non-traction, walking beam, spudding rigs, rotary and combination outfits—a machine for any depth, every formation. Outfits furnished with power or without. We furnish famous **Armstrong Special Gasoline Drilling Engines** with patented speed-controlling lever of drilling end of machine. Changes instantly and absolutely controls speed of engine. Non-slides as steam power. Our engine removes last objection to gasoline power for drilling. Broad guarantee protects you fully. A branch now in Saskatoon to take care of our Dominion trade. Confer with us on any technical question. **WRITE FOR BIG 184-PAGE ILLUSTRATED CATALOG**—The book fully explains well drilling and shows how **Armstrong Machinery** simplifies it. Tells how new men have jumped in and made big successes with little or no experience. If you are interested in well drilling write for this book. Sent free on receipt of 12c to cover postage. **ARMSTRONG MFG. CO., 611 Second Avenue, Saskatoon, Sask., Home Office and Factory, Waterloo, Iowa**



"I clear \$50 a day above expenses, right along!" THOS. KELLEY.

Why Well Drilling Beats Threshing

An **Armstrong Well-Drilling Outfit** costs from one-half to one-third that of a threshing outfit, can be operated every day in the year, and pays from two to three times the profit. Proving wonderfully attractive to threshermen, farmers, railroad men—to all seeking steady work and a profitable business of their own. Complete outfits furnished with or without power. (18)

THE STORY OF TWO FARMS AND ONE FLASH



RUINED BY SIMPLE NEGLIGENCE OR THE FOLLY OF BEING UNPROTECTED

WE PAY FOR ALL LOSS

Inflicted by lightning on any structure and its contents if said structure has been rodded by our ninety-nine p.c. pure copper cable. We give an absolute guarantee to this effect, and we know we are taking no risk in doing so.

IN OUR TEN YEARS' BUSINESS AS ELECTRICIANS

No building which has been protected by the "TOWNSLEY" system has ever been damaged by lightning storm, while others in the immediate vicinity have gone up in smoke.

IT CANNOT HAPPEN

And our protecting cover (which is the least expensive insurance you ever paid) not only guarantees you against loss of property, but the inconvenience arising from such destruction, and the double loss in being put out of business till it has been replaced.

Write us at once for full particulars.

Agents wanted in Western Canada

197 Main Street

Winnipeg

O. W. TOWNSLEY, Manager



SAVED BY TOWNSLEY AND TAKING NO CHANCES

99 PURE COPPER

CANADIAN LIGHTNING ARRESTER AND ELECTRICAL CO. LTD. WINNIPEG

99 PURE COPPER

A Trip to the Rumely Factories

The Rumely Company, of La Porte, Indiana, has established firmer than ever its reputation for broad-minded, liberal treatment of employees. This Company has just concluded a week's trip of seven factories where Rumely Power-Farming machinery is built.

The trip was arranged especially for the managers of the forty-four Rumely branch houses and their "Honor" salesmen. Its object was two-fold: to bring the men who sell Rumely goods in closer touch with the men who manufacture, and to reward the 1912 "Honor" salesmen.

In addition to the field men, General Sales Manager B. G. Baker, Divisional Sales Managers Witmer, Tecktonius, Donovan and Bush; Foreign Sales Manager Berghoff and other department heads and stock holders also made the trip. Dr. Edward A. Rumely, the Company's general manager—responsible for the birth of the new Rumely Company, also joined the party at several points on the journey. In all, about 225 men were invited to participate.

Branch managers and salesmen were brought from all parts of the United States and Canada for the trip. With the home office men they met in St. Paul, Minnesota, Sunday, January 5th.

A "Special" train of fourteen Pullmans left St. Paul early Monday for Stillwater, Minnesota, where the Company builds gasoline tractors. After inspecting the plant and enjoying the hospitality of the Stillwater people, the party left for the next factory. The plan for the entire week provided for night runs and daily inspections of the plants.

The factories visited in addition to Stillwater were: the Falk Company, at Milwaukee, where the Rumely Oilturn Engine is built; the Grand Detour Plow Company, at Dixon, Illinois, whose entire output consisting of gang plows, walking plows, harrows, listers, cultivators and other machines has just been taken over by the Rumely Company; the Rumely plant at Battle Creek, formerly the Advance Thresher Company; the Seager Engine Works, at Lansing where the famous Rume-

In order to advertise in different sections of the country where we have no agents, the wonderful investment opportunities in real estate in the new and fast growing towns of Tofield and Camrose, Alberta, I will, as general sales agent of the Company owning the properties, give away my commissions to a limited number. Lots are sold on easy payments. My commissions take care of your first payment. Answer this advertisement today.

I WILL SEND YOU MY CHECK TO MAKE THE FIRST PAYMENT

Under this exceptional offer you not only save 10 cents on every dollar, but it gives you your immediate selection, and 30 days to investigate before you are out any money on the second payment. All I ask of you is to send the names of five of your friends who might be interested. Then if any of these five buy I will divide my commission with you. Write today and let me tell you all about Tofield and Camrose with my complete plan.

N. R. LADD, General Sales Agent

Canada West Townsite Co., Ltd.

600 Somers St Bldg. :: :: WINNIPEG, CANADA

ers
PHOID
water.
reshing
the most
through
in the
the
tractive
men—to
rottable
the Dur
(74)
rime. Son
no proce
question
and show
little or no
postage
free, from

ly-Olds engines are built; the Omega Separator Company of the same city, whose entire effort is devoted to building Rumely Cream Separators; the Rumely Plant at Richmond, Indiana, formerly the Garr-Scott & Company Factory; Robinson & Co. of the same city, who build the Rumely Automatic Hay Baler and a new product, the Rumely Ensilage Cutter; and finally on Sunday, January 12th, the Home Office town, La Porte, where the famous kerosene-burning tractor is built.

All along the lines the most hearty welcome was given the Rumely host. Courtesies were extended that have brought the Rumely officials into more intimate touch with the local factory men and the factory cities. The good that will come from this to the company, the local plants, and the cities is beyond estimation.

Never before in the history of the farm implement business has such a gigantic undertaking been attempted. The work entailed was tremendous—the expense considerable. But each is quickly dissipated in the benefit which the men associated with the undertaking derived from it.

The visit to the factories was an eye-opener to managers and salesmen alike. Many had never before seen such busy, well-equipped factories as those of their own Company. These men will go back into the field with a fresh inspiration from having seen every detail of the manufacture of the goods they sell.

The trip has likewise brought the Rumely men and managers in closer touch with each other. It has established more firmly the already remarkable spirit of co-operation between them which made the past year an unusually successful one. For 1913 greater things are promised. This trip is an auspicious beginning.

The Value of Firmness

It has been well remarked that "firmness is a very important quality, whether of the mind or of the body; it is one that recommends itself to worthy consideration. We all admire it more or less; those who do not comprehend its full value will often wonder at and respect it. We like to see firmness in a government, because it assures us that the ordinary course of our political and social life is not likely to be disturbed, and we feel that the continuance of many of our most esteemed privileges depends upon it. Sailors like to sail with a captain whose firmness may keep them in proper control in fine weather, and provide for their safety in storms. Workmen

generally prefer a master who keeps firm discipline before one who is always uncertain of his intentions. Children are happier under firm management than when left to alternations of severity and indulgence, or to a take-care-of-yourself system. Animals, too, are affected by firmness; it is well known that lions or tigers have sometimes been prevented from making their attacks by those they threatened showing a bold front. Horses know when they have a firm rider on their back, and will often throw off a weak one. We prefer firmness in buildings, also; it gratifies us to look on some old tower that has withstood the shock of time for a thousand years or more; and we shrink from trusting ourselves in an edifice which has the character of being unsound or unsafe. On all hands, then, it appears that firmness is a desirable quality; it partakes of the nature of decision, and if people would but exercise it a little more than they do at present, they would find good account in so doing, if only in resisting temptation."

About Motive

Whatever one undertakes, whether it be in the activities of business, in school or college, in games and sport or in the domain of friendship, success will be in proportion to the depth and urgency of the motive. All the historic friendships show this; all the triumphs gained in business, in agriculture, or in the professions, demonstrate the fact that no one will forge to the front whose motive is not sufficiently strong to make him indifferent to hardship, careless of fatigue and eager to do his best. The motive, too, should not be wholly selfish. The miser's motive in hoarding money is low and mean. The motive of the philanthropist, whose aim is to benefit those in need, is high and noble. An urgent motive like that of the miser degrades character. An urgent motive like that of the philanthropist elevates character.

Without a sufficient motive, one gets nowhere. The railway train may have a superb equipment, luxurious cars and a splendid engine, but it stands inert and useless on the track until the fires are lighted and steam is up, or until the electric spark is ready to send it forward. In daily life and in Christian life we shall have power only as we have motive.



Some self-made men look the part.—J. W. Babcock.

Be a Co-operator!

Co-operation Makes For Economy In Buying as Well as in Selling

Some Farmers' Associations Are buying their seeds from us in Carloads owing to the lower prices and the saving of freight charges.

Why not your Association? We can supply Seed Grain which has no superior for purity and freedom from weed seeds. We know the history of our seeds, which were grown either on our own farms or from our seeds by contract growers.

We Sell Any Quantity of Marquis Wheat, Abundance Oats (General Crop and Registered), Banner Oats, O.A.C. 21 Barley, Mensury Barley, Eclipse Barley (Registered), Premost Flax, Wilt Resistant Flax, Common Flax.

Some of this grain won prizes at the great Dry Farming Competition, which was open to the World

You Take no Risk For if our Seeds do not please you return them and we will refund your money and pay freight charges both ways.

The Mooney Seed Company LIMITED

"Seedsmen To Men Who Care"

WILLOUGHBY BLOCK SASKATOON, SASK.

You saw this advertisement in this magazine. Don't forget to say so when writing.

Banker's Review for 1912

Continued from page 58b

many parts of northern Saskatchewan, particularly in those districts which in past years have suffered from frost, there is now a pronounced tendency on the part of the farmer to acquire live stock, but want of capital renders this development a very slow one. If the farmer could readily borrow money with which to carry cattle, it is clear that in the districts above mentioned a great impetus would be given to mixed farming.

The labor shortage problem is also dealt with, but we note that the Bank does not take account of the progress of labor-saving appliances that are now being placed on the market to meet the congestion of work at harvest time and the impossibility of obtaining the necessary "hands" just when and as long as they are required for the ingathering of the crop.

Concluding this portion of its report, the Bank says: "The situation calls for concerted action on the part of the governments, and of the railways, banks and other large business interests, not only to promote the adoption of better farming methods, but to provide means of financing the progressive farmer who desires to go into stock raising. We cannot force the development of mixed farming, but we could seek to remove the difficulties in the way. The losses suffered in numerous districts from damage to grain by wet and frost, and the disappointment of farmers generally because of the recent drop in grain prices—occurring coincidentally with high prices for all live stock—render the present a peculiarly opportune time at which to inaugurate a vigorous movement to encourage diversified farming.



Was This Only Horse Sense

A certain man living in a New England village lost a horse one day, and, failing to find him, went down to the public square and offered a reward of five dollars to any one who could bring him back.

A half-witted fellow who heard the offer volunteered to discover the whereabouts of the horse, and, sure enough he returned in half an hour leading the animal by the bridle.

The owner was surprised at the ease with which his half-witted friend had found the beast, and, on passing the five dollars to him, he asked:

"Tell me, how did you find him?"

To which the other made answer:

"Wal, I thought to myself where I would go if I was a hoss; and I went there, and he had."

All Point the Way to Success



Are the only Machines

By the use of which you can be absolutely sure that every kernel is treated. They were manufactured to meet the great demand for a thoroughly practical machine which would handle seed grain in such a manner as to ensure the thorough wetting of each kernel and at the same time remove the smut balls as well as king heads, wild oats, pin oats, rag weeds, light seeds, etc.

Prof. Henry Bolley, N.D. Agricultural College, says: "Smut is one of the great drawbacks to the growth of wheat in the Northwest. The farmer ought to object to the growth of smut for every reason, especially as he is in a position to object with the best hope of success. He can prevent the appearance of smut in the crop which he has for sale."

THE OWENS Smut Machines

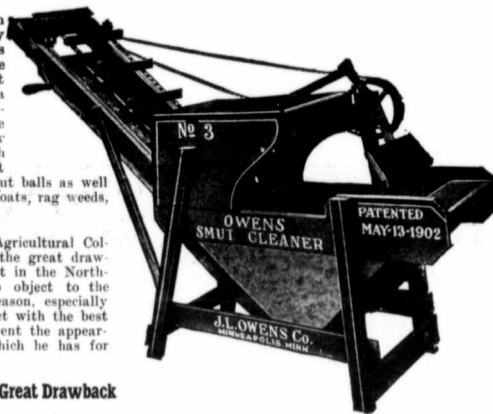

THE OWENS Smut Machine Removes This Great Drawback

Made in two Sizes, No. 3, 30 Bu. per Hour; No. 4, 50 Bu. per Hour

Send for our Free Booklet "SMUT FACTS"

The Harmer Implement Co., 181 Princess Street
Winnipeg

Stocks at Winnipeg, Regina and Saskatoon

The Gregg Line of Eveners Is Complete in Every Detail

It is not equalled by any other, in quality of materials, simplicity of design, or in any points of construction. The Eveners are heavier by 1/4 of an inch than any others on the market.



GREGG FIVE-HORSE GANG PLOW EVENER

The line includes all combinations, from the Two-Horse Wagon Doubletrees, to the Six-Horse Tandem Evener.

GREGG MFG. CO., Winnipeg, Man.

We have a Catalogue for you.

GET AN "IDEAL" TRACTOR FOR RESULTS

Results with a tractor depend largely upon the design and construction of the machine. A tractor rightly designed, properly constructed and with high-grade materials throughout, will be good for a long life and return the buyer much more than the amount invested.

Our "IDEAL" Tractor took first place in its class for design and construction at the Winnipeg Trials last year, being well in advance of the four other entries on those vital points. We employ nothing but the best materials at whatever cost.

In the "IDEAL" Tractor you get a steering device similar to those used in high-priced automobiles, the vibrating Bosch system of ignition which works perfectly in coldest weather and does away with batteries, a splendidly balanced engine that delivers the maximum power at the minimum cost, automobile type cooling system that does its work on a small amount of water, and many other features that will tell in service.

Write for our Tractor Booklet, and learn why the "IDEAL" is best suited to Western conditions.

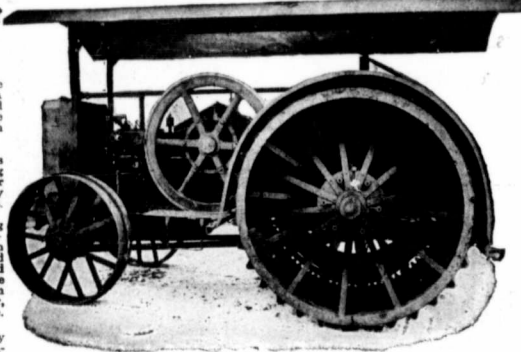

GOULD, SHAPLEY & MUIR COMPANY, LIMITED

Winnipeg Regina Calgary

Manufacturers of

"IDEAL" Gasoline Tractors Windmills and Pumps of every description
"IDEAL" Hopper-Cooled Gasoline Engines Wood Sawing Outfits, etc., etc.
"Maple Leaf" Grain Grinders

You saw this advertisement in this magazine. Don't forget to say so when writing.



MONITOR DRILLS



Double Disc Single Disc

Low Down Press

Shoe and Hoe

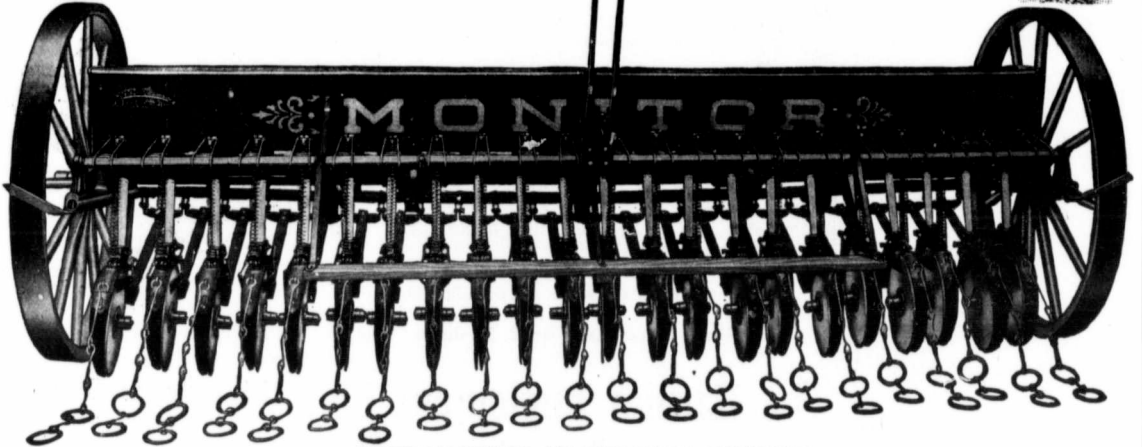

FACTORY OWNED BY THE PLOW COMPANY

The Famous Glengarry Line

Steel Auto Seat
Top Buggies
Runabouts and
Driving Wagons
Surreys
emocrats
Business and
Delivery Wagons

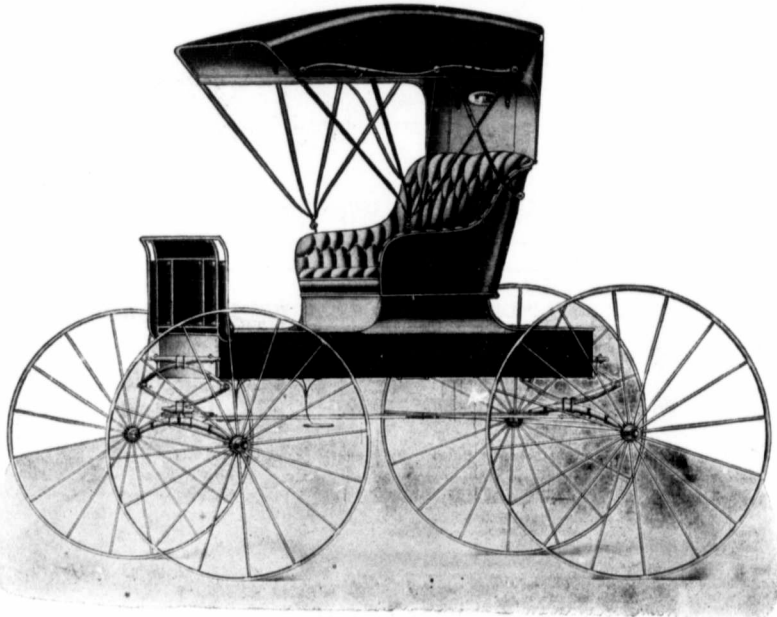

Write us for a full line
of catalogs, terms and
prices. Address your
mail in our care and
make our office and
salesrooms your head-
quarters during
BONSPIEL WEEK



Canadian Moline Plow Company

WINNIPEG

CALGARY

EDMONTON



Moline Plow Company Buys Harvester Plant

Increases Capital Stock from Nine Million to Thirty Million Dollars



"The Mysterious Stranger"

A deal of unusual interest in implement circles, owing to its significance in marking the entry into the Harvester field of another well-known implement concern, has been closed, whereby the Moline Plow Company, of Moline, Ill., takes over the business, factory, and good-will of Adriance, Platt & Co., Poughkeepsie, N. Y.

The Moline Plow Company manufactures the well-known Flying Dutchman Line, and the addition of Binders, Mowers, Reapers and Corn Harvesters completes the line and makes it one of the most important factors in the implement field.

In connection with this purchase, the Moline Plow Company has also increased its capital stock from \$9,000,000 to \$30,000,000. A portion of this increase is doubtless for the purpose of purchasing the above-mentioned plant, and the remainder will probably be used to care for its rapidly increasing business, both in the United States and foreign countries, and to provide additional facilities for manufacture.

Although the Moline Plow Company originally built only Plows, the acquisition of this Harvester line is but following out a policy inaugurated some years ago by the purchase of the Mandt Wagon and Henney Buggy Factories, and

continued later by that of the Freeport Carriage, Monitor Drill, Acme Steel and McDonald Pittless Scale Plants.

Adriance, Platt & Co., were established in 1855, and have been active in Reaper and Harvester trade ever since. The Adriance Line is well and favorably known in the Eastern States, where it has enjoyed a large trade, although it has never been aggressively pushed in the western sections of the country. It has also enjoyed a large foreign trade. The taking over of this concern gives the Moline Plow Company entry into certain territories where their selling organization has not been complete, especially in the Eastern States.

The manufacture of the Adriance line will be continued at Poughkeepsie and the factory enlarged to take care of the additional trade, due to the large increase in business which will follow the sale of this line in the central and western portions of the country.

The Moline Plow Company enjoys an enviable position in the trade, both at home and abroad, and with this increase in working capital and manufacturing facilities and latest addition to the Flying Dutchman Family, we predict for it a period of unparalleled success and a position in the trade second to none.

Address: CANADIAN MOLINE PLOW COMPANY, WINNIPEG

A Travelling Tractioneering School

How ineffective is a fine machine in the hands of a man who does not understand the principles of its construction and who is not thoroughly familiar with its disposition! The gas tractor has had a rough time of it at the hands of the "Knocker," but like everything else that is the fruit of a common-sense idea, it not only survives but it is flourishing today under a clear sky of public confidence.



Principal A. C. EISENACH

It isn't a paucity of good machinery we suffer from today, but a decided want of experienced men to handle it, and with the purpose of supplying the big demand for good men, the travelling branch of the "Indiana School of Tractioneering" is now making a complete itinerary of Western Canada.

In Winnipeg over 200 young farmers are now undergoing a two weeks' drill under the joint auspices of this School and the Rumely Products Company at the headquarters of the latter Company on Dufferin Avenue. Principal A. C. Eisenach is in charge of the itinerant staff of instructors in Winnipeg, and at the close of the fortnight's course, will move on to Regina and thence to Saskatoon, etc.

As we write, a large class is being conducted at Calgary, and dates have been arranged as stated in last month's issue of The Canadian Thresherman and Farmer, at Yorkton, Edmonton, Estevan and Brandon.

This is certainly the age of power farming, in which most men agree that the ruthless drudgery imposed on horse flesh can no longer have a place in rational agriculture, but that the horse should be engaged on its legitimate function on the farm. Without complaining, it is true, horses will attempt anything that an engine will tackle, but what a wretchedly poor game it is to set them at it!

Apart from the appeal to the humanities, it is far from being a

paying proposition. "Time" is taking on more and more of the color of "money" as the days go by, and having regard to the rapid progress that marks our day, it has been found that except at ruinous cost, any number of horses will not do the quantity or the quality of work called for and do it in the time in which it must be executed, to catch every

run a steamboat or a railway engine.

Hence the tractioneering schools and it requires no remarkable exercise of the prophetic gift to see that there is no profession now established or in the making that is so likely to open up the very finest possibilities to enterprising men with brains as it that of the traction engineer.

possible hour in our very short Western season. Therefore the mechanical power. The engine has come to stay, and the man to work it has come to stay also. There were not many "engineers" in the schools or out of them when Fulton ran his first steamer up the Hudson, and lots of hoary heads shook apprehensively when this young fellow and the next wanted to know about engineering and

In the Indiana School, instruction is given by means of lectures and demonstrations. A thorough understanding of the subject is given by the liberal use of models, charts and diagrams. The lecturers take up in order in the morning sessions the subjects of Principle of Operation and Types of Engines, Combustion and Carburetors, Ignition, Lubrication and Cooling Systems. General

Hints on Troubles and Remedies and Practical Suggestions on Plowing, Discing, Seeding and Harvesting with the Tractor.

In the afternoon sessions students are given the opportunity of working with actual engines, and of making adjustments under the guidance of expert instructors.

The faculty of the Indiana School of Tractioneering is made



Plowing

HACKNEY AUTO PLOW



Wood Sawing

Seeding

Discing

Harrowing

Harvesting

Threshing



Orchard Work

Road Grading

Feed Grinding

Cutting Ensilage

Hauling Loads, etc.

DO your Plowing, Seeding, and all other work on the
 farm where power is needed, with a **HACKNEY AUTO-PLOW**—the great *One-Man* machine—universally known as the greatest labor-saving device for the farmer ever invented, the *only* tractor that can be worked *economically* on farms of average acreage. It eliminates drudgery, solves the vexatious labor problem, and enables you to do your work better and cheaper—when weather, soil and crop conditions are all in your favor



The Hackney Auto-plow may be equipped with disc plow, disc harrow or road grader attachment—attached in same position as mould board plows shown above.

Before you buy a tractor we want you to investigate the Hackney Auto-Plow—the one-man outfit. Our catalog, describing the machine in detail, photographs and testimonial letters from users will be mailed on request

Hackney Manufacturing Company
 605 Prior Ave. St. Paul, Minn.

You saw this advertisement in this magazine. Don't forget to say so when writing.



Pupils of the Indiana Tractioneering School, Rumely Yards, Winnipeg

OLIVER PLOWS



Oliver No. 1 Gang. Four horses hitched abreast, but none walking on the plowed ground.

THE Oliver No. 1 gang gives the driver the great advantage of being able to hitch four horses abreast without any of them walking on the plowed ground. Hitching four horses makes the work of the horses easier, and makes the plow work better. But on the ordinary plow four horses cannot be hitched abreast without either punishing one horse by making him walk on the plowed ground all day, or putting an unusual side strain on the beams (and every farmer knows that a heavy side strain on the beams will ruin any plow.)

The Oliver No. 1 gang has its beams landed so that no matter whether two, three or four horses are hitched abreast there will be no excessive side strain on the beams. Therefore, there is no danger of ever springing the beams on the Oliver No. 1 gang. When four horses are used the hitch is between the beams, and the pull on each beam is direct, along the beam.

The No. 1 gang is strongly built for the hard work of Western Canada, for which it has been especially designed. The shares and moldboards are all adapted to the heavy work of turning the hard soil found in this locality.

This plow is an easy one to handle because the levers are long and powerful. They are all placed within easy reach of the driver.

It is equipped with soft center steel shares, having extra thickness of hardened steel where the greatest wear comes.

The Oliver line of plows includes walking plows, sulky plows, gang plows, tractor gang plows, in fact, it includes a plow suited for every need of the Western Canadian farmer.

For further information, write the nearest branch house.

WESTERN CANADIAN BRANCHES:

International Harvester Company of America

(INCORPORATED)

At Brandon, Man.
Calgary, Alta.

Edmonton, Alta.
Estevan, Sask.

Lethbridge, Alta.
North Battleford, Sas.

Regina, Sask.
Saskatoon, Sask.

Winnipeg, Man.
Yorkton, Sask.

OLIVER PLOWS ARE BUILT AT HAMILTON, ONTARIO, CANADA

You saw this advertisement in this magazine. Don't forget to say so when writing.



Farm Building Foundations

(2nd Article)

By Prof. L. J. Smith

HAVING set the batter boards for a building, the next operation is to either dig the trenches for the wall as in the case of a barn, or first excavate for the cellar, if the building is to be a modern house. The walls for a barn will be considered first.

There has been in the past a great tendency to slight the

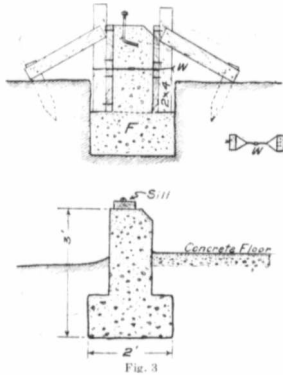

foundations of barns and small buildings. Indeed, it is still hard to convince many a farmer of the necessity for a good foundation wall. Poor foundations cause unequal settling of the building and are largely, though not always, responsible for the building getting out of shape. This not only causes an unsightly appearance, but produces unequal strains on the various parts of the framework of the building, often weakening the structure and making it an easy victim to heavy wind storms.

If the owner puts in his own foundations, and it is not a difficult job, they will be but a small part of the total cost of the barn. Figure 3 shows a good type of a concrete wall for a well-built barn. It is three feet deep and one foot thick including a footing, F, two feet wide and one foot deep to allow the weight of the building to be distributed over more surface. In ordinary practice, footings are made twice as wide as the wall is thick and as deep as the thickness of the wall. The wall shown extends about a foot above the surface of the ground,

which keeps the moisture away from the woodwork both on the outside of the wall and the inside, where the concrete floor might be frequently washed down.

If the ground is firm, a trench can be dug and the concrete for the footing mixed pretty wet and poured in the forms without much tamping. If the earth is loose, the footing will need forms of rough 2 x 12 inch plank staked in as shown in Figure 4. In nailing the plank to the stakes do not use very long nails, in order that the forms may be taken down without difficulty.

After the concrete footing has been in the forms for three or four days, the forms for the wall proper can be set (Figure 3) and the concrete wall put in at once. If planks are used as forms for the footing, they may be pulled up at this time without harm to the concrete if some degree of care is observed, and used as part of the forms for the wall. The side planks may be supported by stakes and braces as shown in the figure, or by nailing one-inch pieces across the tops of the vertical 2 x 4's as in Figure 5. To keep the forms from spreading at the bottom wires, W, are passed around the 2 x 4's and twisted tight in the middle with a stick or rod. Pieces of 2 x 4, cut equal to the width of the wall are placed between the planks just below the wires to keep the forms in place. Then when the concrete is put into the forms in sufficient amounts to hold them in place, knock out the pieces of 2 x 4.

When pouring the concrete, anchor rod should be set every six or eight feet to bolt the sill firmly to the wall. Use $\frac{1}{2}$ or $\frac{3}{8}$ inch bolts for the purpose. Before the sill or wall plate is placed on the wall, it is well to coat the under side with tar or asphaltum, for wood next to concrete is apt to rot, especially if the wood gets damp frequently. When setting the sill, bed it in cement mortar of one part of cement to two parts of sand, to have it lie perfectly level and the better to keep out the cold.

If a lighter wall is desired, Figure 4 illustrates a very good type. The footing is the same size as in Figure 3 but the wall is only two feet deep, including the foot-

ing. Such a wall will require three cubic feet of concrete per running foot of the foundation, while the wall in Figure 3 takes four cubic feet. It is a good idea to place the wall a little to one side in cases of such shallow foundations, in order that the sill will rest exactly over the center of the footing. If this is not done, the footing has a tendency to settle unevenly and let the wall tip outward.

When excavating for the cellar of a house, it is generally advisable to first take off the surface soil and place it in a separate pile in order that it may be used again as top soil around the house after it is finished, making it easier to get a good lawn started again. If the top soil is to be moved as described it must be mentioned in the specifications. If written specifications are not used, a distinct understanding should be had with the contractor, which should include the thickness of the soil to be removed.

It is a good practice to make the surface of the ground immediately adjacent to the house a little high and slope uniformly away from the foundation walls. This will cause the surface water to run farther away from the building before it sinks into the ground which helps to keep the cellar free from dampness. It will also make it possible to build

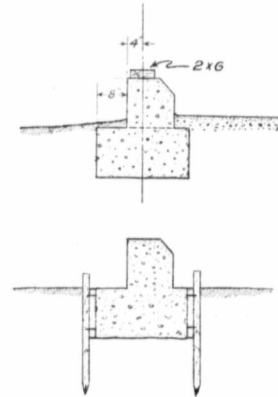

the house on a little higher level, which is an important consideration in a flat country.

The forms for a concrete wall for a house are shown in Figure 5. The wall is here shown to be

of solid concrete up to the sill, though more often it stops at grade line, which is the line to which the outside earth is levelled, and the rest of the wall, sometimes called "underpinning," is made of stone or concrete blocks. In many localities hollow concrete blocks are almost entirely used for this purpose. They make a nice uniform wall, easily put up, and where sand and gravel are plentiful, they are very cheap. An 8 or 10-inch block is ample for the ordinary wooden house. Having dead air spaces, they will keep out the frost better than an equal thickness of stone.

The wall shown in the figure is one foot thick, which is ample for house foundations. This width might safely be cut down to 8 or 10 inches, if the sand and gravel are of a good quality, and if the concrete work is carefully done; but the size of the footing should not be changed. Such a wall might not keep out the frost so well where the winters are very cold but the wall would be sufficiently strong.

The footings are put in first, then the forms for the wall are set as shown in the figure. A 2 x 4 inch or 2 x 6 inch is laid along the inner edge of the top of the footing and well staked in position to keep the vertical 2 x 4's in line. The 2 x 4's are put up about $3\frac{1}{2}$ feet apart, depending on the height and thickness of the wall, and the length of the plank used for the forms. In heavy walls for large buildings 2 x 6's should be used. Wires are twisted at W to keep the uprights from spreading.

How to do the Concrete Work

It is not intended to discuss fully in these articles the various methods of mixing and placing concrete. The manufacturers of cement publish a large amount of good literature on this subject that can be had for the asking. No one should have difficulty in doing the ordinary job of concrete. The principles are easy to understand and the tools required few and inexpensive. Concrete is the most durable and one of the strongest of building materials. The test of over two thousand years have amply proven its durability.

The proper proportions for a concrete wall is one part of

Continued on page 69



MAYTAG^{CO} LTD



SOME old things are worth preserving at any cost, but IT PAYS TO BURN AN OLD FEEDER UNLESS IT IS

A RUTH FEEDER

Last year we made certain promises to every man who bought a "Ruth." We said it would enable him to get through the biggest and the toughest threshing job he ever tackled without a hitch—in fact to do all and more than all we undertook to do with the "Ruth" in terms of our cast-iron warranty.

Result: Our customers are satisfied. We know it from the hundreds of unsolicited letters of appreciation we have received from men to whom we sold this feeder.

RUTH FEEDER WARRANTY

"The Ruth Feeder is Warranted to Feed any make or size of Separator to its full capacity, with any kind of grain in any condition whatsoever, bound, loose, straight, tangled, stack burned, wet or dry, PILED ON THE CARRIER IN ANY WAY YOU PLEASE, without slugging the separator cylinder or loosening a spike, and to do a faster, cleaner and better job of feeding and to WEAR LONGER AND COST LESS FOR REPAIRS than any Feeder manufactured by any other Company in the world."

Now that you have decided to buy, the next question which naturally arises is, which

RUTH FEEDER

Do you prefer? One is just as good as another, and any one of them will Put an end to your Feeder troubles forever

RUTH with the Crank Shaft Motion
RUTH with 14 Foot Extension Carriers

RUTH with the Rotary Motion
RUTH with Swinging Elevators

You, as threshermen, know that much of the success of the operation of a separator depends upon the self-feeder. You are not the only ones who realize this. The manufacturers of threshing machines are wise to this fact as well. That is why the "Ruth" is supplied by practically every threshing machine concern in the United States and Canada as part of their regular equipment.

Any Threshing Machine Company doing business in Canada can supply you with a RUTH Feeder, and we will FURNISH THE ATTACHMENTS TO PUT THEM ON SO THAT THEY FIT PERFECTLY. When we say ANY Thresher Company, we had in mind more especially the following, as they have practically all bought the RUTH of us, and we are not only willing but anxious to fill all orders they may favor us with during the coming season.

Sawyer & Massey Co.
International Harvester Co.
Waterloo Manufacturing Co.
American Abell E. & T. Co.
Haug Bros. & Nellermeoe Co.

Garr-Scott & Co.
Burrige Cooper Co.
Canadian Port Huron Co.
Buffalo Pitts Co.
The Rumely Co.

Robert Bell E. & T. Co.
Geo. White Sons & Co.
Nichols & Shepard Co.
Reeves & Co.
J. I. Case Threshing Mach. Co.

John Goodison Thresher Co.
Aultman & Taylor
Minneapolis Thr. Co.
Huber Manufacturing Co.
Fairbanks-Morse Co.

Geiser Threshing Machine Co.
Geo. Smith, Sons & Co.
McDonald Thresher Co.
Compagnie des Jardins
Matthew Moody & Sons
A. & T. B. Farquhar

WHEN WRITING FOR CATALOGUES, PRICES OR FURTHER INFORMATION PLEASE MENTION THIS PUBLICATION



MAYTAG^{CO} Limited, Winnipeg, Manitoba



Annual Dinner of Sawyer-Massey Company

The annual dinner of the officers, heads of departments and visiting representatives of the travelling staff of the Sawyer-Massey Company, was held at the Hotel Waldorf, Hamilton, Friday evening, January 10th, with nearly one hundred present.

Mr. T. S. Depew, secretary-treasurer of the Company, acted as chairman, and after an interesting menu was discussed, various toasts were proposed and responded to.

The keynote of the evening was struck by Mr. R. Harmer, president of the Company, in an informal address which reviewed briefly the seventy-six years of the Company's history, touched on the gratifying increase in the business of the Company during the past three years, and the efficient and loyal co-operation of the factory and sales organization.

There were present not only officers, heads of departments and shop foremen, but the Ontario travelling staff in force and a score of representatives from the Provinces of Alberta, Saskatchewan and Manitoba, working out of the Winnipeg and Regina branches.

A musical programme was provided which put the finishing touch to the thorough enjoyment of the evening.

Mr. Robert Christie, father of T. B. Christie, works manager, was an honored guest, and was called on for reminiscences. Mr. Christie was for over forty-four years actively engaged with L. D. Sawyer & Co., Sawyer & Massey Co. Ltd., and Sawyer-Massey Co. Ltd. His remarks were timely and of keen interest.

Mr. Turnbull in his able manner spoke of his organization, dwelling on the work and the loyalty of his travellers and office force, of their unbounded faith and enthusiasm in the goods and the plant behind them. He congratulated the president, Mr. Harmer, and the factory executives on the strides the Company was making, evidenced in the larger number of new, high-class, special tools, and the additions they had made and were at present making to their already large plant. The high efficiency of the goods was a matter of congratulation to both the travellers and their customers, and Mr. Turnbull displayed great enthusiasm over the goods and the loyalty to the Company and himself of the men working with him.

Mr. White, in a few well chosen words, emphasized the satisfaction

it was to the travellers to sell such a product as the Sawyer-Massey Co. was making and of the pleasure it was to him personally to have such a fine body of men working with him. He referred to the cordial feeling existing between the men themselves, their splendid loyalty to the Company and himself, and the pleasure it was to them to see the additions being added to the plant and the installation of such fine equipment.

The banquet was the culmination of a week spent by the travelling representatives of the Sawyer-Massey Company in visiting the factory and studying factory methods and product.

These meetings stimulate the interest of the travellers, the factory and sales executives, and result in giving a better product and service to the customer.

The Westerners left on a special car and at the station the loyal, enthusiastic spirit of the men towards the Company again asserted itself in the hearty cheers for the president, Mr. Harmer and for the factory and the men behind it. This was followed by three hearty cheers for the Westerners who were acclaimed the Premier Boys selling the Premier Engine and Threshing Goods made in Canada. As the train pulled out they gave their well known slogan:

Who are we? Who are we—
P-e-o-p-l-e.

Western Representatives of the Sawyer-Massey.

It were not best that we should all think alike; it is difference of opinion that makes horse races possible.—Mark Twain.

The late Clark Russell, whose will has just been proved, was a cripple in later life through rheumatism. He once told a friend that, though he did not aspire to a high place among romantic writers, yet as a rheumatic writer he was on a plane by himself.

MARQUIS WHEAT CHEAP

Get my SURPRISINGLY LOW PRICES AND FREE SAMPLES of specially grown stock. Seed secured from Indian Head Experimental Farm. Get genuine Marquis. THE WORLD'S CHAMPION WHEAT FOR 1913—MARQUIS—WAS GROWN FROM SEED SUPPLIED BY ME. QUALITY COUNTS.

SEED OATS PEDIGREED BANNER, ABUNDANCE AND GARTON'S No. 22. BIG STRONG SEED, with the vigor and vitality of new land in them. Money back guarantee, with you as judge and jury. Prices that defy competition. Keep your seed grain, grass and clover seed money until you investigate my quality and prices.

Chambers of **HARRIS McFAYDEN** Winnipeg
Commerce FARM SEED EXPERT Man.

SATISFY THAT YEARNING!



GET A HOME FOR YOURSELF

OUR TWO BOOKS of Bungalow, House and Cottage plans contain hundreds of designs, including floor plans. Designed by licensed architects. For any of them we supply Blue Prints and Specifications at about \$5.00 per set. Made to order by an architect would cost \$50.00 to \$75.00. Any carpenter can build your home with our Plans, Specifications and Blue Prints. Both books sent prepaid and duty free for One Dollar. Regular price a dollar each. If Blue Prints are purchased later we allow you the dollar. CATALOGUE FREE.

Frederick J. Drake & Co. Department 30, 1325 Michigan Boulevard
CHICAGO, ILLINOIS, U.S.A.

THE GOLD MEDAL WINNER

In Class "C" for Gasoline Engines at the
Winnipeg Motor Competition . .

Was equipped with the

CUDDY STEERING DEVICE

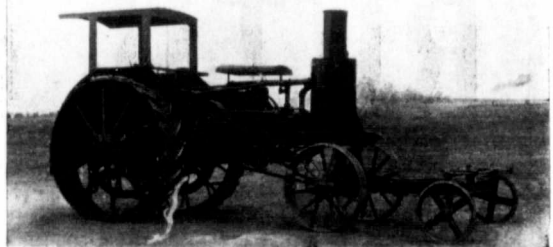

The "CUDDY" was the only steering device that was used by any contestant although there were others on the ground.

The demonstration given on the 1912 Motor Contest field by an Aultman and Taylor tractor equipped with the Cuddy Steering Device showed beyond the question of a doubt that it benefits the engine, and at the same time does not require any more power to operate it. In a motor contest every ounce of fuel counts, and no contestant can afford to use a drop more than is necessary.

With the Cuddy Steering Device the engine using it plowed at a fuel cost of 36.8 cents per acre, the lowest in the class, at the same time making the best speed of any engine in the contest. A Cuddy Steering Device will save its cost in a season to say nothing about the ease with which your engine can be operated.

THE WESTERN STEEL & IRON CO. LIMITED
Sole Manufacturers and Distributors
WINNIPEG, MAN.

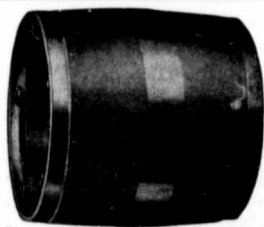

THINK BACK—HAVE YOU EVER STRIPPED THE COVER FROM A SAGGED PULLEY? TRY

The Rockwood Paper Cylinder Pulley

NO BOLT HEADS OR RIVETS TO CUT THE BELT
NO COVERING TO STRIP AND COME LOOSE

The Rockwood Mfg. Co. 1828 English Ave.
Indianapolis, Ind.

A New Light in the Country By Olive Lanier

I spent a week-end recently at a country house in Manitoba—one of the comfortable homes of our well-to-do farmers, and I saw on a table in a cosy living-room, a lamp of simple design, on a thin shaft, with an opalescent shade, that filled the compartment with a light like the sun, just as it sinks in the west on a Manitoba September evening. It was the most remarkable lamp I had ever seen, not unlike the ordinary electric library lamp in appearance but puzzling, because there was no wire in sight, and we were many miles away from any electric plant, and I sat there in the soft, steady and mellow light of that wizard lamp and wondered what manner of lamp it was and from whence it got its power. Vainly I scanned the room for wires without letting my host observe my curiosity. Was it an electric light? Surely it must be; and yet I had never seen one like it—or equal to it. It was so agreeable and cheerful, so rich in tone, one might read by it for hours without the least fatigue. It was unlike the yellow and inadequate electric incandescent or the cold greenish ray of the gas mantle. It rested my eyes and I was at perfect comfort in the most effulgent and satisfying light I had ever heard of indoors.

At last, in a high pitch of womanish inquisitiveness, I asked my host about it. What was it? Where did he get it? How did it work? And he told me it was a Pitner Gasoline Parlor Lamp that was introduced only about two or three months ago. "Well, Pitner be praised," said I, "for giving the country people, of this and other lands, a lamp that beats electricity, for a fraction of the cost. Banish the candle and the old melancholy oil lamp, with its depressing smell and ever-present danger; the country folks have got a safe and cheery light now like the clear noon-day."

I made a mental note to look it up when I got back to Winnipeg and I went straight to the office of the Pitner Gasoline Lighting Company, at 62 Albert Street. I had shared, in a way, the public distrust of gasoline for lighting purposes, and when Mr. Phillips, the managing director, showed me how absolutely safe it was, I was deeply impressed. He filled a quart measure half full of gasoline and without the formality of reassuring me, dropped a lighted match into it. To my astonishment there was only a soft blue light emitted, and when he placed a folded newspaper on the measure, it was extinguished. He then repeated the test and poured the

Built Heavy for Engine Work!



More Durable Than Horse Discs

The Emerson Engine Disc has solved the Engine discing problem. The disc blades are one-third heavier than the horse disc. The disc spools are twice as heavy and with wide flanges to reinforce the discs.

Axles are heavier, contain more bearings, and the entire machine is much more durable in its construction.

than horse disc harrows. Two sizes cut 8 and 10 feet, with 32 and 40 either 16 or 18 inch disc blades.

The front discs throw the dirt outward and the rear discs throw it in. Cultivates the ground thoroughly but does not ridge it.

EMERSON Engine Disc

is the only disc harrow that is heavy, strong and durable enough to stand up and do satisfactory engine work.

Weight can be placed on the pan or platform if desired when working very hard ground.

The levers are on the outer end of the gangs and operate much easier than the center lever construction. Rear section can with its lever be set at greater

or less angle than front section, yet the operation of one lever changes the angle of both front and rear sections on one side.

Furnished with or without the EMERSON Force Feed Drill or Seeder attachment, and a good engine can walk right away with three of them hitched side by side, discing and seeding a stretch thirty feet wide.

The New EMERSON Force Feed Seeder

on the rear section sows all kinds of small grains. Adjustable to sow the desired number of bushels per acre and every grain is planted at an even depth and is thoroughly covered.

The advantage of this type of seeder is that the

grain is not piled one seed on top of one another, but is sufficiently scattered over the bottom of an inch-and-a-half wide seed furrow to insure best growing conditions. The uniformity of depth is important as it means uniformity of growth and ripening.

Write For Big Disc Details

Ask us how the many advantages of this machine, backed by the 60-year EMERSON experience and reputation can benefit you. Address

EMERSON-BRANTINGHAM IMPLEMENT COMPANY THE LARGEST LINE OF FARM MACHINERY IN THE WORLD. ROCKFORD, ILLINOIS, U.S.A.

Tudhope, Anderson & Co., Ltd., 1195 Princess St., Winnipeg, Man.; Canadian Sales Agents. Regina, Sask. Saskatoon, Sas. Calgary, Alta. Edmonton, Alta. Lethbridge, Alta. Brandon, Man. Yorkton, Sask. Swift Current, Sask.

For saw this advertisement in this magazine. Don't forget to say so when writing.

burning gasoline into the lamp. Once more he applied the newspaper and the flame went out.

Mr. Phillips told me that while this parlor lamp had only been on the market three months, over ten thousand had already been sold and I can well understand it. It is safer than electricity, gas or even candles. It will burn upside-down or right-side up. You can roll it on the floor while burning. I wouldn't advise it, but a child might play with it, and here is what the makers tell you about it:

"This wonderful lamp can be burned at any desired brilliancy, from five candle power to 125 candle power. By far the cleanest, safest, most practical, convenient,

useful and economical light made. A child of ten years of age can take complete care of it. It can be filled in one minute and lighted in 45 seconds. Needs filling only about every two weeks. Burns about 30 hours on one filling of three pints of ordinary gasoline such as is used in stoves, automobiles, etc."

Farm Building Foundations

Continued from page 66

cement to six parts by volume (a 1-6 mix) of sand and gravel as they come from the pit. Four bags of cement equal one barrel and in Canada contain about 3 1/2 cubic feet. In mixing concrete by hand what is known as "a two

bag mix" is commonly used; that is, two bags of cement are mixed in this case with six times that volume of sand and gravel.

In a smaller job the cement and sand and gravel may be measured by the shovelful. Where quite an amount of concrete is going to be mixed it pays to make a measuring box as shown in Figure 6. It should have a volume equal to one barrel of cement, which would give a box about 11 1/2 x 18 x 30 inches. The box should have no bottom. Its long sides should be made longer than the box to form handles.

Concrete is often mixed on the bare ground but it is preferable to do the work on a mixing board, 8 x 10 feet being about right for

PATMORE NURSERY CO.

Patmore's Reliable Seeds, Trees, Shrubs and Plants

can be found growing in every district in Western Canada, and we gratefully acknowledge the many nice letters WE ARE CONSTANTLY RECEIVING from our customers. We know our Seeds and Products are the best for this Western climate, and our customers are proving this. We can buy seeds to sell at half the price we do; but we won't handle that sort; we want the best only.

READ THIS LETTER—A SAMPLE OF MANY MORE:

Gentlemen,—We had great success with your seeds last year. I intend to use them exclusively this year. From one-tenth of an acre we harvested 40 bushels of fine onions, and from three-quarters of an acre we harvested 400 bushels of carrots. The cabbages were splendid and weighed from 6 to 16 pounds each. From 1½ acres we put in our cellars 5000 heads besides marketing several hundreds during the summer.

(Signed) ROBERT HAMILTON.
Saskatoon, Sask. JAMES GUY.

We make a Special Nursery Offer for this Spring:
FOR \$10.00 WE WILL SEND
50 Currant and Gooseberry bearing bushes of best varieties.
100 Raspberry Plants, best varieties.
12 Plum and Fruit Trees, young and thrifty, 2 to 3 feet high.
All of the above for \$10.00.

WHY NOT HAVE A GOOD FRUIT GARDEN?

We have to offer this Spring:
200,000 Maples, 5 to 10 feet.
200,000 Poplars and Willows, 3 to 4 feet high.

It is compiled jointly with Messrs. SUTTON & SONS (for whom we are Special Agents for Canada) and is a safe and profitable guide to Horticulture in the Canadian West, as we list and describe only such varieties as we have found reliable in our 25 Years of Practical, Steadily-Acquired Knowledge of Western Horticulture.

Write to-day for **Our Catalogue.**

SASKATOON, SASK. THE PATMORE NURSERY COMPANY BRANDON, MAN.

RELIABLE SEEDS-TESTED FOR WESTERN CONDITIONS

You saw this advertisement in this magazine. Don't forget to say so when writing.

board makes it easier to shovel when mixing the materials, and insures a concrete more free from dirt. To make a two bag 1-6 mix, set the box near one end of the platform and fill it level full of sand and gravel, raise the box and level off the top of the pile and set box on the pile and repeat the operation two more

times. Next spread the sand and gravel with the shovel, empty two sacks of cement on the heap, and we have the proper amounts and are ready to mix. Mix the dry cement and gravel thoroughly until the resultant mixture is uniform in color. Then add water. One good way to get the water in the mixture is to spread the mix out until the surface is fairly level. Now pour on

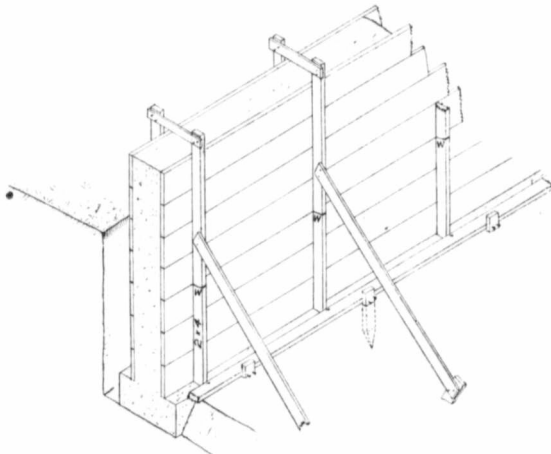

Fig. 5

the water and spade vertically into the mix giving the shovel a quarter turn each time to get the water down into the mixture. Shovel into a long heap and with one man on each side of the heap shovel the mixture into a long pile at the other end of the board, taking only a little at each swing of the shovel and giving the mix-

ture a spreading movement by giving the shovel a slight twist as the mixture is leaving it. Continue mixing the wet concrete until it again has a uniform color. Enough water should be added to make the concrete for the wall slushy. It can then be easily dumped into the forms and will be soft enough so that a man can get on it with rubber boots, and tread it down, sinking five or six

inches into the mixture. At the start, if it is hard to get down between the forms, the concrete can be puddled with a 2 x 4 to bring the air bubbles to the surface. If the concrete is not mixed wet as described, it must be tamped with a heavy tamp in order to get a strong, compact wall. It should at least have enough water so that the moisture will come to the surface when it is well tamped.

Concrete should be placed in position as soon as possible after water has been added to the mixture, as the cement then starts to set or harden at once. If it cannot be used within half an hour of the time that it was mixed wet, it should not be used at all.

Field stones can be thrown into the concrete without weakening the wall. They should be clean, however, and should be thoroughly wet down before being put into the wall in order that they will not absorb too much moisture from the concrete and thus weaken it. Large stones that are equal in size to the thickness of the wall, should be broken before being used. Where stones are thus used, the concrete must be made quite slushy.

It is well to leave the forms up for a week unless it is desired to put a smooth plaster coat on the outside of the wall, in which case the forms should come down a few days earlier. Knock off the braces and the vertical scantling and the plank should loosen up quite readily.

While the proportions of the mixture of concrete just described give a wall that is amply strong,

the 1-6 mixture is not waterproof. Such a wall is commonly made waterproof by thoroughly coating the outside below grade line with

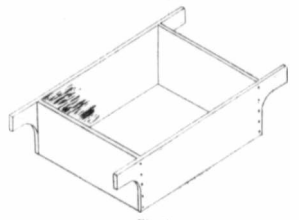

Fig. 6

tar or asphaltum. An old brush or broom will do for applying this waterproofing.



FIRE AT AVERY PLANT

Just as we are going to press word is received that a fire has occurred in the plant of the Avery Company, Peoria, Illinois. We are, however, advised that this fire was confined entirely to the blacksmith shop, with a loss estimated at \$75,000. All of the other departments of the Avery Company were running as usual, and as arrangements were made with a number of the other manufacturing concerns in Peoria to take care of the blacksmith work, we are advised that there will be practically no delay in the shipment of goods.



The intelligence and resolution of man in overcoming the physical difficulty are to be the source of our pleasure and subject of our praise.—Ruskin.

Sawyer-Massey Gas Tractors

We
are not
in a
Combine

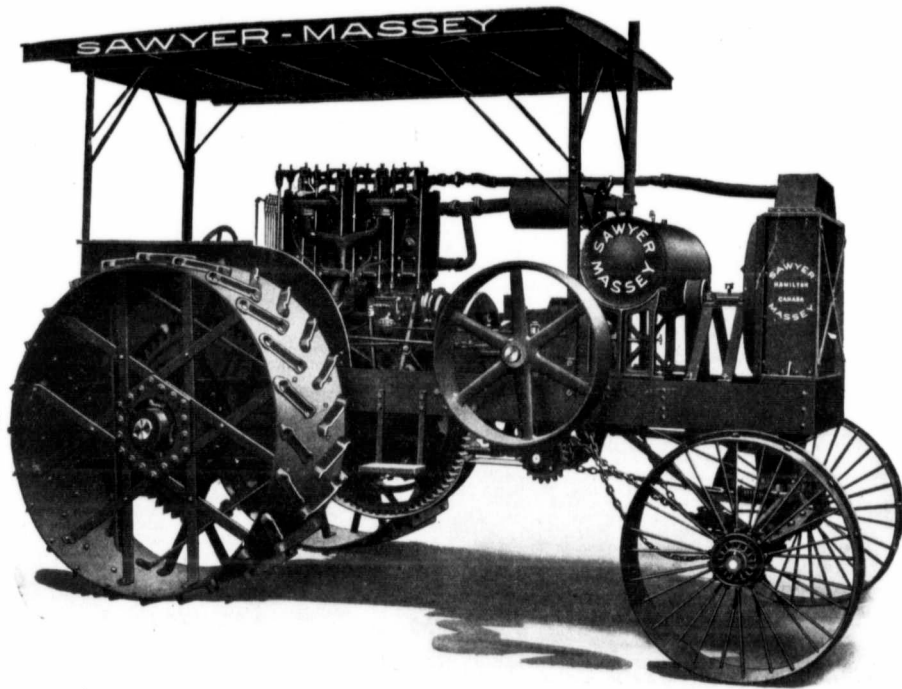

25-45 Horse Power

We back up our product with an experience of 76 years. We give you a tractor that has proven itself in the Canadian West to be the premier tractor. It is designed and perfected by Canadians and built by Canadian workmen. Although rated at 25-45 H.P. it usually exceeds this by ten per cent.

Our Engine is simple in construction, it is easy to operate and to keep in order. It is built by men who know positively the class of work that is to be done.

MOTOR—Is a 4-cylinder, 4-cycle vertical type, water cooled, the 4 cylinders ensure a continuous flow of power to the gearing, thus lessening strains. It has less vibration than any other tractor.

BEARINGS—Large new departure double row ball bearings used in bevel gear box. Crank shaft bearings are all die cast, Cam shaft bearings bronze and main shafts are babbitted.

CARBURETOR—Kingston floating ball.

CLUTCH—Two-shoe expanding.

COMPENSATING GEAR—Four pinion.

COOLING—Closed system.

WHEELS—Front, 40 inches diameter; 12 inches wide. Rear, 68 inches diameter; 30 inches wide. Extensions supplied if required.

GEARING—All contained within the frame.

Let us send you our catalog on Gas Tractors, it is very comprehensive and gives full specifications and illustrations

Sawyer-Massey Co. Limited

Manufacturers of

Steam and Gasoline Traction Engines, Threshers and Road Making Machinery

Head Office and Factory: **Hamilton, Ont., Canada**

Branches: **Winnipeg, Man. and Regina, Sask.**

You saw this advertisement in this magazine. Don't forget to say so when writing.

THE CANADIAN BANK OF COMMERCE
Report of Annual Meeting for 1912

At the annual meeting of The Canadian Bank of Commerce held in Toronto on 14th Jan. the statement presented showed profits for the year of \$2,811,806.42, the best in the history of the Bank, which has grown rapidly during the past few years.

After the reading of the Report the General Manager, Mr. Alexander Laird, addressed the shareholders, saying: We have closed another year with a record of uninterrupted prosperity, and we take pleasure in submitting a report which will compare favorably with any previous statement in the Bank's history.

In reviewing the business of the early part of the year we have to note a steady development. Great industrial activity, accompanied by large orders for manufactured goods of all kinds, gave an impetus to business which at once arrested our attention and produced a feeling of concern lest we should have difficulty in meeting the requirements of our customers.

We had expected the gradual return of better conditions in the great financial centres which, by permitting the marketing of a large amount of first-class securities, would enlarge the supply of available capital, but untoward events in Continental Europe and the uncertainty surrounding an exciting Presidential campaign in the United States made this impossible.

With the amalgamation of the Eastern Townships Bank our capital was increased to \$15,000,000. The average capital employed during the year was \$14,210,437, and the net earnings on this amount were \$2,811,806.42, an increase of \$506,397 over last year, being at the rate of 19.78 per cent. This result was attained after making the usual provision for all bad and doubtful debts, and a thorough revaluation of the entire assets of the Bank.

We are pleased to report that an examination of the accounts of the Eastern Townships Bank leaves us no reason to doubt the value of our purchase, and we record our appreciation of the zeal and the hearty co-operation of our associates in the difficult task incident to the adjustment of so important an acquisition.

We disbursed in dividends \$1,568,622.43, being at the rate of 10 per cent per annum, and an extra bonus dividend of 1 per cent for the year. The policy

of paying bonus dividends until such time as we are confident of being able to maintain a higher rate would seem to be a wise precaution, in view of the extraordinary development of our business and the desirability of making ample provision for any contingency likely to arise.

We have expressed the hope that our building programme could be curtailed, but the acquisition of the large territory covered by our eastern branches, and the continued growth in the West, necessitated the opening of a considerable number of branches requiring the building and remodelling of offices on an extensive scale. We have also a serious problem to face in the changes absolutely essential for the proper accommodation of Head Office and Toronto branch, our present premises having been for several years quite inadequate.

The increase of the staff, now numbering 3,000, required the appropriation of \$75,000 for the Pension Fund. We have added \$2,742,180 to Rest Account and carry forward a balance of \$771,578.88 in Profit and Loss. The Bank's Circulation account showed important fluctuations during the year, the minimum reached in January being \$10,403,322 and the maximum in November \$16,690,709. We had occasion to take advantage of the emergency provisions of the Bank Act amendment of 1908 early in October, and we closed our statement with a circulation of \$1,422,864 in excess of the amount of our paid-up Capital.

If the Bank Act introduced at this session of Parliament should be passed in its present form and a "Central Gold Reserve" established there will be no apprehension of a security of currency at a time when the emergency provisions are not operative; for with the deposit of gold or Dominion notes in the custody of trustees the banks will have the privilege of issuing their own notes to the full amount thus deposited. This will undoubtedly be a very important step towards ensuring that the business of the country should not be embarrassed through lack of currency. It is evident, however, that there will be no profit to the banks in availing themselves of the suggested privilege, and as we have reached the time when the need of currency is beyond the present limits of the bank's power to supply, it is desirable that in addition to the adventitious aids so wisely provided in the New Bank Act, the banks should anticipate an increasing demand for bank-note currency by the issue of additional currency.

During the year our deposits increased \$51,651,727. There was a considerable accession of special amounts which will be withdrawn in due course, and we received \$19,111,119 as a result of the Eastern Townships Bank amalgamation. The ordinary deposits show a very handsome increase. Current loans and discounts increased \$52,753,247 and call and short loans \$2,577,730, compared with last report. Investments in Government bonds, municipal and other securities were increased by \$2,821,024 and cash resources by \$1,625,271.

You will notice from the report of the Board of Directors the large increase in the number of our branches. We fully realize our responsibility in undertaking to control so many units in a great bank, and the importance of arranging for a complete organization of competent and loyal associates, with geographical divisions which thoroughly cover the field of our operations. We endeavor as far as possible to clothe our Superintendents and Managers with authority for a prompt discharge of the duties of management, and believe we

have succeeded in perfecting a system which meets every reasonable requirement. The distribution of branches at the close of the year was as follows:

Table with 2 columns: Branch Name and Number. Includes Alberta (49), British Columbia (42), Manitoba (23), New Brunswick (2), Nova Scotia (13), Ontario (79), Prince Edward Island (5), Quebec (91), Saskatchewan (53), Yukon (2). Total in Canada (359). Also includes Newfoundland (1), London, Eng. (1), United States (4), Mexico (1).

Total number of Branches ... 360

The number of the Bank's shareholders has increased during the year from 4,142 to 5,656, the increase being principally due to the taking over of the Eastern Townships Bank. The stock of the Bank is now quite widely distributed, not only in Canada but abroad, as will be seen from the following figures compiled as at the close of our year:

Table with 3 columns: Province/Country, No. of Shareholders, and Amount Held. Includes Ontario (1,388 - \$4,087,500), Quebec (1,127 - 3,213,650), Maritime Provinces (702 - 1,544,450), Western Provinces (118 - 242,950), Great Britain (1,569 - 3,204,400), United States (609 - 2,549,950), Other countries (83 - 157,100). Total: 5,656 \$15,000,000.

We have referred to the provisions of the new Bank Act for increased note circulation, and would like to advert to the proposal that is now being considered, of creating a system of independent audit to supplement what has always been regarded as complete and satisfactory in every well-organized bank. There can be no question as to the importance of a strict supervision of all matters pertaining to our banks, and we should welcome any plan which make for more efficient management and a proper recognition of the great responsibilities we are called upon to assume. We are disposed to believe that with the co-operation of the Canadian Bankers' Association working through the various Bank Clearing houses effective service could be rendered in the correction of abuses and the perfecting of methods for the encouragement of sound banking. We have possibly not taken advantage of our opportunities in this respect.

The Bank Act will probably sanction under proper liens and assignments the loaning of money to farmers and ranchers on the security of grain and cattle and other live stock in their possession. This will, undoubtedly, be a great advantage in many instances, and will at least legalize a practice already quite common, and probably tend to prevent hasty marketing of produce. As a matter of fact large advances are made to farmers on the security of notes, but actually upon what they possess in the way of products of a future and their reputation for honesty and ability, always an essential consideration when lending money. We have no hesitation in stating that our farmer customers are, almost without exception, satisfactory borrowers. Our aggregate advances to farmers run into large figures, estimate, at \$15,000,000 for the Western provinces.

Despite the money stringency during the closing months of 1912, and the fear that we may feel the pinch for some time to come, there are offsetting influences at work. The wonderful revival of trade in every branch, the bountiful harvests throughout the land and the consequent enormous increases

in traffic on the railways, afford excellent grounds for the assumption that the unusual prosperity we are enjoying is on a sound basis. There is, therefore, some warrant for the belief that with reasonable care and judgment in measuring our commitments there will be a continuance of prosperous conditions for the coming year. We must, of course, reckon with the adverse circumstances prevailing abroad, for in conducting a world-wide business we are sensitive to these influences. We are hopeful that with the settlement of present difficulties in Europe and the return of trade to normal channels, any apprehension for the immediate future will be dispelled. We are likely to experience on the part of investors a very decided reluctance to pay fancy prices when we come to dispose of the securities now awaiting a favorable market, and we should be prepared for a revaluation which will probably mean a higher yield for the purchaser.

The adoption of the Report was then moved by the President of the Bank, Sir Edmund Walker, C.V.O., who spoke as follows:

President's Address. The area of Canada in which the Bank is directly interested has become so large that we have decided to present the information collected regarding its industrial position in a new form. We shall hereafter include in the statement made to our shareholders reports from those senior officers of the Bank who have charge under the General Manager of the various geographical divisions of the Bank and who are better qualified than we are to set forth the facts regarding such district.

The year has been one marked, even in comparison with recent years of large expansion, by a continued increase in immigration, in building operations of all kinds, especially in connection with railroads, in foreign and domestic trade, in bank deposits, indeed, in almost everything connected with the prosperity of a country. Our object in stating what is so well known is that we may consider the causes of our rapid growth and whether in the methods of our expansion there is anything which needs to be checked. Our financial requirements are mainly determined by the volume of immigration. It is because of this that we must build so largely, and this also is the main cause of the excess of our imports over our exports. The immigration for the calendar year, December, being estimated, was 394,784, an increase over the record year of 1911 of 13 per cent. The immigrants came to us from forty-one countries and were divided as follows: British, 144,830; American, 140,456; from other countries, 109,498. In order to transport them to their inland destination 800 passenger trains of ten cars each, averaging 50 persons to each car, would be required. In the last two years we have added nearly 10 new people to each 100 people already in Canada taken as a whole, but as over half of these immigrants have gone to the Western provinces, the proportion of newcomers to these provinces in the same period has been about 20 to each 100. The population of Saskatchewan has increased five-fold in ten years. Clearly this is proportionately the largest immigration problem ever handled by any country. In order to house, settle, and arrange transportation for these people, we must borrow very largely, and as long as such streams of newcomers continue we are likely to be borrowers on a large scale, at least for many decades to come. In the excess of our imports over exports and in the volume of our securities sold abroad in order to settle that difference, one can clearly see the strain put upon Canada by this enormous accession of new people. The total of our foreign trade for the fiscal year ending March, 1912, was \$874,538,600. Our imports were \$559,220,000 and

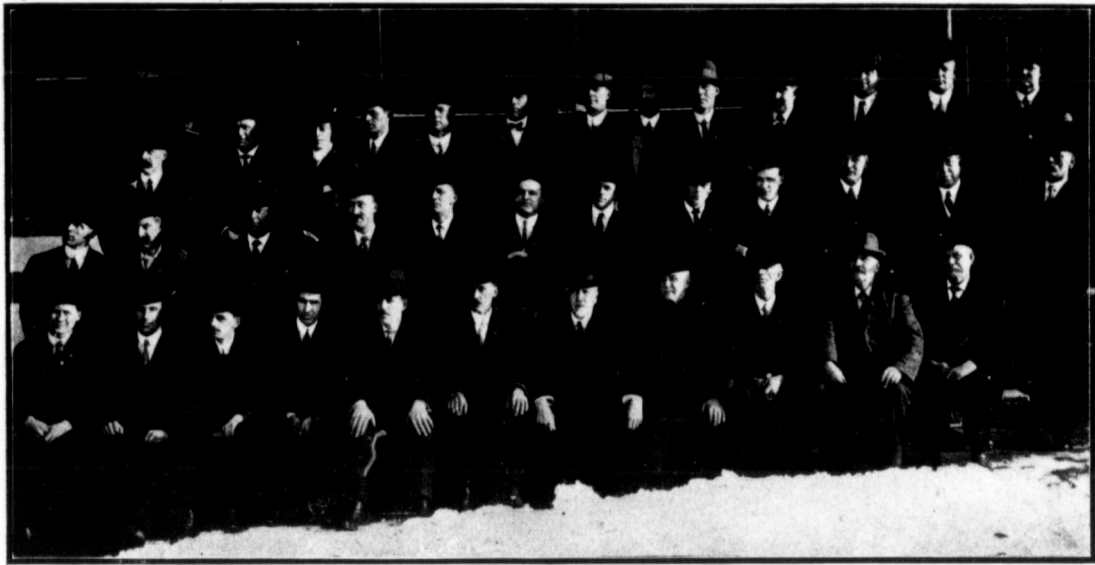

GROUP OF SAWYER-MASSEY MEN—ANNUAL DINNER, 1913

Top Row reading from left to right: W. White, Joint Winnipeg Manager; Joseph Clarke, C. S. Symmonds, H. O. Grubbs, S. Warren, G. H. Cook, J. H. Turnbull, Regina Manager; C. R. Laird
Second Row reading from left to right: J. Wade, J. Levy, A. Fleming, J. W. Math, Wm. Galbraith, E. J. McKee, Joseph Ritchie, M. J. Allan, Chief of Engineering Dept.; T. R. Bell, E. J. Ramsay, T. A. Drummond, Works Superintendent; George Beaton,
Bottom Row reading from left to right: Wm. Keith, J. McEwing, T. B. Christie, Works Manager; J. A. Findlay, W. R. Miller, W. A. Bailey, R. Harmer, President and Gen. Manager; T. S. Depew, Secretary-Treasurer, S. W. Tripp, James Paterson, J. C. Ramsay.

our exports \$315,317,000, the balance against us being \$243,903,000, and the figures for the half year ending September, 1912, show imports on an even larger scale. The imports of iron and steel in various forms from raw material to highly complicated manufactures amount in value to \$95,000,000. Almost all these articles are already being made in Canada, but not in sufficient quantities, or not of high enough quality, to satisfy our requirements. It is to the last degree desirable that such articles should be made at home, and to the extent of say \$50,000,000 or \$60,000,000 they clearly should be. With the exception of motor cars and parts to the extent of \$7,387,000, and a few other items, the whole of this amount may be safely attributed to the erection of new structures or the opening up of new farm lands. It is this large difference between our exports and imports which causes us to send so many securities to the London market; and if it were true that we are offering too many securities it would mean that we are importing too many goods or exporting too little, or both. Doubtless, some Canadian securities are offered which should not have been created, and doubtless our imports are unwisely increased to some extent by the extravagance of an unusually prosperous people, but the main cause each year is the same. We need more than ever new mileage of railways, vast quantities of new rolling stock, warehouse and port facilities, municipal expenditures in hundreds of new towns and an enlarged scale of improvements in all the older municipalities, the building of ordinary roads, bridges, etc., in many new areas of settlement, the creation of plants for new industries and the general increase of existing plants throughout all Canada, the erection of private dwellings in greater numbers, and of more permanent construction than in the past, and many other forms of betterment which need not be detailed. But while our needs are mainly measured by our immigration, we art apt to forget that it is the investor in our securities who has the power to determine finally the pace of our expansion. For every dollar we wish to fix in permanent improvements somebody should have saved a dollar, and at this extravagant moment the borrowers throughout the world exceed those whose savings take the form of loanable capital. It is for us, therefore, to consider not so much our needs as the opinion of the investor regarding our securities, and the condition of the

world's money market. If we do this we must conclude to restrict our building operations as much as possible for the moment, and we must expect to pay a higher rate of interest for our requirements. Men with business experience before entering upon building operations, large or small, assure themselves that the needed money is available. It is only our municipalities and reckless promoters who incur large obligations before they are sure of the necessary investor in the securities they propose to offer. Many of our towns and cities who have refused to consult the banks, find themselves embarrassed as a result, and improvements which may be wise and much needed, must be postponed for the moment. The existing securities will doubtless be absorbed in the near future, but at lower prices than heretofore in order to meet the investors' expectations of a higher return. Our municipalities, however, should seriously consider whether during periods of such rapid expansion the tax rate should not be largely increased. In the days of Western expansion in the United States 25 and 30 mills on a fairly high valuation of property were not uncommon rates. Again, should we not pay for local improvements in a far shorter time than we do? The Western cities of the United States make their local improvements by the issue of short term securities, the average life of which is usually not more than five years. Such securities often carry six per cent interest and do not appeal to the same class of investor as do long-term municipal debentures. We can easily see the bad effect on the credit of our municipalities of adding the heavy cost of local improvements spread over long terms, to the ordinary general debt. Such a system as that followed in the United States would probably not find favor with the subdivision promoter because it would be a powerful check on all speculative real estate schemes. At least a year ago it became generally known that there were many Canadian securities in existence which had not been absorbed by the investor and that real estate speculation was proceeding at too rapid a pace. Undoubtedly the knowledge of these facts has exercised some restraint upon our people. Transactions in inside city properties have probably been larger than ever but the sub-division promoter has not prospered. Direct investments of British capital in agricultural lands to be re-sold have been made in both the East and the West on a large scale. In common with the rest of the world

we are living in a time of high prices, and the incidence of these prices on those who have fixed incomes or earnings is so heavy as to constitute the greatest economic difficulty we have to face. I shall not attempt to deal fully with a subject which is being studied by Government Commissions in many leading countries and which will, let us hope, be referred to an international commission. There are so- forces which affect the general trend of prices, others which may cause any particular commodity to go above or below the line of the general trend, and again others which are local and produce such apparent anomalies as higher prices for foodstuffs in cities nearer sources of cheap production as compare with more remote centres of consumption. Without, therefore, discussing the effect of an enlarged and cheapened supply of gold, the enormous increase of credit partly made possible thereby, and the effect of many other forces causing a general upward trend of prices, we may profitably consider some local causes which put the people of Canada at an unnecessary disadvantage. One of the most powerful and inexcusable local causes for the high price of food is the condition of our country roads. It must be clear that if a farmer has to travel ten or twenty miles to a city to sell his produce, every hour of delay to himself and his horses and wagon, every bushel or pound less he is able to carry, every day lost in the length of the life of his horses and wagon, cause just so much increase in the cost of the article he has to sell. To the extent that this needless and cruel loss might, if avoided, partly add to the farmer's profit and partly lessen the cost to the consumer, the state of our roads is little short of a crime. If the bad roads around a city cause the price of food to be much higher than it need be, one of the results is to enable producers, hundreds, perhaps thousands of miles away, to enter into competition with the farmer in his own county, because the cost in transit over one mile over many miles of good railroad. This competition may help the consumer by keeping prices from rising still higher but it will not bring the price below the point fixed by the extra cost from the bad local roads. It will not do any good for those of us who live in well-paved cities to blame the farmers for bad roads. They cannot be expected to build good roads entirely at their own expense, and good roads will not come so long as we wait for anything

as unfair as this. It is not that we do not know how to construct good roads. We know how well what we should do, but we hesitate to do it. In the excellent report on Highway Improvements in Ontario for 1911 there is a sufficient abstract of the systems adopted by the various countries of the world and by thirty-three States in the United States; of these that are in use those in the State of New York seems to be the most complete. Under this system roads are classified as follows:
(1) State roads built at the entire cost of the state.
(2) County roads to which the state contributes one-half, the county 35 per cent, and the township 15 per cent. For maintenance the state collects from the townships \$50 per mile per annum, the remainder being contributed by the state.
(3) Township roads, to which the state contributes one-third of the cost of construction.
Can the people of Canada be made to realize that every man, woman and child suffers from the evil of bad roads whether they use the roads directly or not? Have we not as much intelligence as the citizens of these thirty-three neighboring states?
Another cause of high prices is the general inefficiency of most kinds of labor. Employment is so easily obtained that the worker is apt to be so lacking in training for the particular calling it falls to his lot to occupy, that for this reason alone three men are often needed to do the work of two. The necessity of buying food for three families instead of two clearly raises the price of food and every non-producer of food in Canada therefore suffers from this inefficiency of labor. Still another evil, tending to high prices and growing rapidly in these extravagant times, is the waste in the use of food. As seen in a modern hotel or dining car this shocks most of us, but in countless families the waste is nearly as bad proportionately. If three animals are bought where only two are really needed, the price of meat is raised for everybody. I must apologize for repeating facts which are so palpable, but in our desire to blame someone else for the suffering caused by high prices, we often refuse to see local causes which largely contribute to it and which we could at least moderate if we chose.
We have often spoken of the tendencies of modern life which increase
Continued on page 79

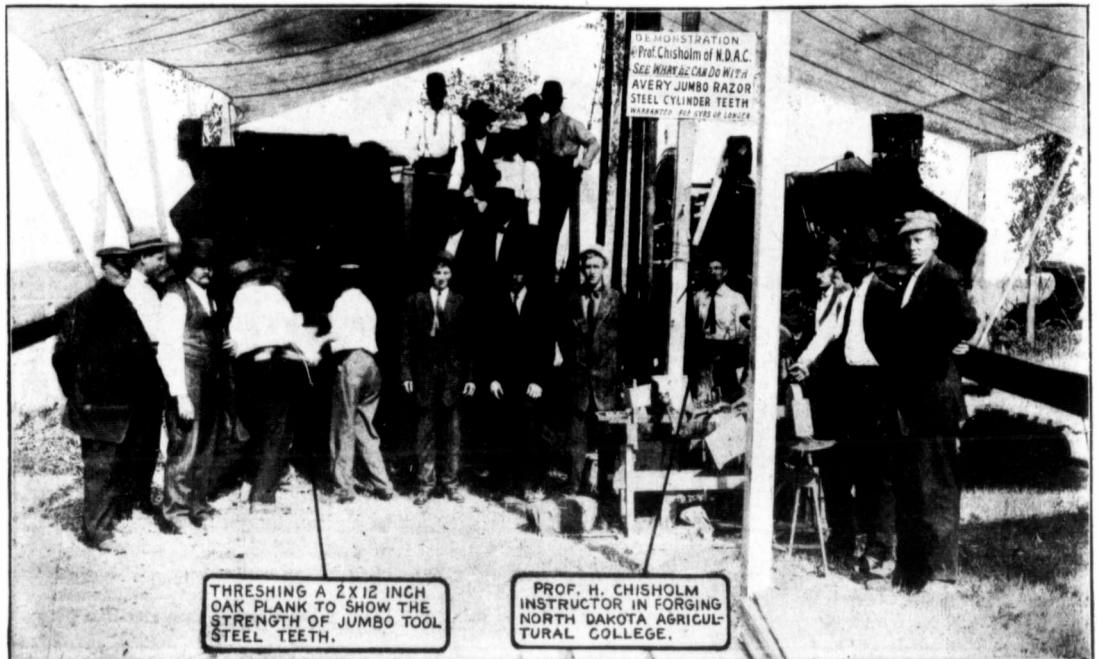

Buy a Separator with Good Teeth

Cylinder teeth are of the greatest importance. The Avery Jumbo Steel Tooth has no equal. You can't afford to bother with cylinder teeth now-a-days. It isn't the first cost of the cylinder tooth, it's the time lost putting it in.

Read these letters; one from the Instructor in Forging at the North Dakota Agricultural College telling about Avery Jumbo Tool Steel Teeth, and the others from men who are operating machines not so equipped.

Read what Prof. Chisholm says about Avery Jumbo Tool Steel Teeth

Agricultural College, N.D., August 14, 1912

Mr. J. B. Bartholomew,
President of Avery Company.

Dear Sir:—

The following report of a demonstration test of the metal in the Avery cylinder teeth, given at the North Dakota State Fair, in July 1912, is herewith submitted:

I have given a thorough examination and test of the metal in the Avery cylinder teeth, and have found in it a remarkable combination of fine crystallization, tensile strength, toughness combined with hardness and ductility. In five days—using both old and new teeth—I found it uniform and homogeneous in quality.

The demonstration consisted in making knives, hatchets, cold chisels of different types, punches, wrenches, wood chisels, etc. Cold chisels were repeatedly driven through cold iron and mild steel without injury to the cutting edge. A chisel was driven through 1/2-inch thickness of cold mild steel leaving the cutting edge intact. Teeth were hammered out, doubled over, and hammered together without fracture. In these tests an ordinary blacksmith's open fire was used, and no special treatment given the metal.

In my judgment the metal in the Avery cylinder teeth is all that the Company guarantees it to be.

Very respectfully,

H. CHISHOLM,
Instructor in Forging, North Dakota Agr. College.

Read these letters from men who are trying to get rid of that terrible Toothache they bought

Berryton, Kans., January 20, 1912

Avery Company,
Peoria, Ill.

Gentlemen:—A short time ago I met one of your agents, and he was showing me one of your "Jumbo" cylinder teeth. I am convinced he knows what he is talking about. He advised me to inquire of you as to the practicability of using the "Jumbo" spikes in my _____ separator, so I am asking you if the "Jumbo" spike can be used in _____ cylinder? I have quite a little trouble with the _____ spikes breaking.

Yours truly,

W. H. WATERS.

Ashland, O., January 7, 1913

Avery Company,
Gentlemen:—

Can you furnish some of your spikes for a _____ separator, 30 in. 12 bar cylinder. If so, please state price of same, and oblige,

R. F. D. No. 2.

KENNETH WITMER
Ashland, O.

Avery Jumbo Tool Steel Teeth are so good that we **guarantee them for life against breakage.** They eat up pitchforks almost like straw, and even spades, wrenches and other articles which accidentally fall into the cylinder almost never break them.

And that's only one advantage you get in buying an Avery—in 27 Field Tests they **saved an average of 99 9-10 per cent of the grain,** they are backed up by the **strongest grain saving guarantee ever given, all castings and shafting are guaranteed for one year against breakage.**

Factory ownerships have been changing. It is your privilege to make a change and select the machine that is most complete in every detail and best meets the requirements of a thresher. Write now for new 1913 Avery "Yellow-Fellow" Separator Catalog and get all the facts.

Check The Catalogs You Want and Mail the Coupon Today

These New 1913 Avery Catalogs are now ready for you. Each catalog shows the machines in natural colors on the front cover. Inside the books are an unusually large number of complete and detailed views of each machine which are extra fine.

Read about the New Avery Sold on Approval Policy on Tractors and Plows.

See the Double-Page Interior View of an Avery Separator in operation showing just how the grain goes through.

Learn about the Avery Strong Guarantees on Steam Engines, Separators, Tractors and Plows.

These are only some of the things you will want to see and read about. Check the catalogs you want on the coupon or write us a postal or a letter today.

EVERY COMPANY
675 Iowa St., Peoria, Ill.

Haug Bros. & Nellerhoe Co. Ltd., Winnipeg, Regina, Calgary
Western Canadian Distributors



Avery Company, 675 Iowa St., Peoria, Ill.
Please mail me your 1913 catalogs checked below:

- Avery Steam Traction Engines.
- Avery Gas and Oil Tractors.
- Avery "Yellow-Fellow" Separators.
- Avery "Self-lift" Engine Gang Plows
- Avery Gasoline Trucks.

Are you in the market? If so, when?

What for?

Name Town R.F.D.

State Date

Western Canada in the Making

Portion of an Address delivered by H. W. Hutchinson, at a Banquet given by him to the Implement Men of Winnipeg, in commemoration of his 30 years' service in the Implement Business in Western Canada

Mr. Chairman, gentlemen, competitors and friends: I cannot express to you tonight my appreciation of the honor you have done me in consenting to be my guests this evening. I exceedingly regret the absence of others engaged in the implement trade that I should like to have had as my guests, but I am deprived of that pleasure because of the illness of some, and the absence of others from the city.

As has been indicated to you by Mr. Hamilton, our worthy chairman, this little festive occasion tonight is to commemorate my thirty years active service in the implement business in Western Canada, and I have felt for some time that I should like to give some mark of appreciation to my competitors, whose unflinching courtesy I have appreciated at all times.

I have not prepared any address, nor any set speech, as I do not think you expect that, nor would you enjoy it. I thought, however, that on an occasion of this kind it might prove of interest to you if I were to make some reference by way of contrast to the conditions that existed in the North-West thirty years ago when I came here, and those that exist today. I have therefore before me a few figures relative to the wonderful development that it has been my good fortune to witness. I know we are all more or less engaged with figures in our business, but I believe that those I shall refer to will prove of interest to you.

It was the morning of the 5th of January, 1883, that I arrived in Winnipeg (a morning very similar to this morning), and the temperature was 30 below zero. I strolled down Main Street, in those days a serpentine trail without any pavements of any kind, and plank sidewalks. I had reached the wonderful City of Winnipeg, which as an Eastern boy I had heard much about, as the famous boom of 1882 had brought Winnipeg very prominently before the eyes of the Eastern people.

The resident population of Winnipeg at that time was stated to be 12,500, with probably 2,500 additional transients, many of whom had gone through the boom of '82 and had either made so much money they wished to revive it again, or had lost so much they were unable to get out of the country. It may surprise you

to know that the total population of Winnipeg and all Western Canada on the 1st of January, 1883, was only 91,812, including half-breeds, Indians and white people: viz.

43,000 resident in Manitoba
32,829 resident in Saskatchewan
15,583 resident in Alberta

The Dominion Government census of June, 1911 gave the West a population of 1,281,058, divided as follows:

Manitoba 454,681
Saskatchewan 453,508
Alberta 372,919

to which we must add 420,000 estimated increase since then.

Crop Area

In 1883 the total area in crop in the whole West was 536,000 acres, and the total yield therefrom, including oats, barley, wheat and flax, was 17,063,000 bushels, and the area in crop in 1912 was as follows:

Province	Acres in Crop	Total yield
Manitoba	5,922,000	182,092,000 bus.
Saskatchewan	9,184,000	237,279,000 bus.
Alberta	2,536,000	66,000,000 bus.
	17,642,000	485,371,000 bus.

From these figures it cannot but be admitted that the development in agriculture has been marvelous, more especially when I tell you that there was not a bushel of grain grown west of Broadview (which as you know is only 250 miles west of Winnipeg), excepting for domestic use. Previous to 1895 the Provinces of Saskatchewan and Alberta were given up entirely to ranching. In 1898, fourteen years ago, Saskatchewan Province had under crop 350,000 acres, and Alberta only 79,000 acres, which yielded 6,552,000 bushels and 2,806,000 bushels respectively of all kinds of grain; while in 1912 the acreage in crop in Saskatchewan had increased to 9,184,000 acres, while that in Alberta had increased to 2,536,000 acres, which yielded 237,279,000 bushels, and 66,000,000 bushels respectively, of all cereals, and yet gentlemen, the total area under crop in 1912 of 17,642,000 acres is less than one-tenth of the total arable land in the three Western provinces capable of producing grain without any further effort than plowing the virgin soil and sowing the seed.

Now if you can let your imagination carry you, not into the distant, but into the immediate future, is it not reasonable to assume that in five years' time thirty million acres will be in crop

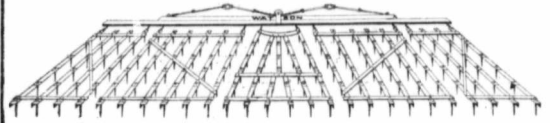

Watson's Steel Boss Harrow

Our New Steel Boss Harrow has won a reputation in the West. It is of proper construction and design to do the right kind of harrowing.

Tooth bars are of angle steel, cross braces are of channel steel. Each tooth is separately fixed in place by a steel wedge. Teeth are dagger-shaped, with edges directly in line of draft. Equipped with pulley hitch evener. Light draft, easy on horses. Width 24 feet. If your dealer cannot supply you, write us direct.

WE SELL—

- | | | |
|-----------------------|-----------------------------|------------------------|
| Channel Steel Harrows | Lawn Goods | Pole and Cordwood Saws |
| Boss Wood Harrows | Turnip Seed Sowers | Wheel Barrows |
| Harrow Carts | Warehouse Trucks | Root Pulpers |
| Pulverizers | Double Trees and Neck Yokes | Grain Grinders |
| Horse Powers | | |
| Straw Cutters | | |
| Heider Eveners and | | |
| Janesville Plows | | |



WINNIPEG

The Comet Magneto Holds First Place

In the minds of hundreds of the leading Gasoline Engine builders, jobbers and dealers.

THE COMET
30 Days
Free Trial



BECAUSE of neatness of mechanical design, simplicity of construction, and GREAT ELECTRICAL EFFICIENCY.

IT PAYS TO BUY THE BEST

Henricks Novelty Co.
1205 St. Paul St.
INDIANAPOLIS - IND.



SMUT Completely Killed

Last season the farmers in Western Canada lost over five million dollars through smut in their grain, even in spite of the fact that by far the largest percentage treated their seed grain. How much was your loss?

The Automatic Seed Grain Pickler picks at the rate of 125 bushels per hour, is self-operating, the weight of the grain supplying the power to operate; the machine is light though strongly built and with ordinary care will last does absolutely perfect work with any and every kind of grain, flax included. Last year we had orders for hundreds of machines more than we could manufacture and although every machine was sold with a guarantee of money back and freight paid both ways if the machine was not perfectly satisfactory in the users' estimation, still we have never yet had returned a single machine.

This machine has proven a huge success for the last two years. Do not allow your dealer to persuade you to buy another machine simply because he has another make in stock, but ask to see this machine; if he is an up-to-date dealer he will have it. But remember, order early. Price, for using formaldehyde \$17.00; built of solid copper for bluestone \$20.00; freight prepaid to your station and a guarantee with every machine. Write for further information or see your Dealer about it.

Dominion Specialty Works

Winnipeg

Manitoba

with a probable yield therefrom of one billion bushels?

With the immigration that is coming to us from all parts of the globe, I predict an even greater development in the future with a corresponding increase in yield.

Railways

When I came to Winnipeg thirty years ago from Toronto, I had to come through the States, as we had no connection with the East over Canadian territory, and it took me four days to make the trip, whereas today I can make the same trip in forty-two hours. The total mileage of railway in the West in 1883 was 1,652 miles, 1,338 of which was the main line of the C.P.R. from Fort William on the east to the foot-hills of the Rockies in the West, and it will be even more surprising to you to know that outside of the main Canadian Pacific artery, there was only 264 miles of branch line in the whole West, while today there is in Western Canada, exclusive of British Columbia, 12,745 miles of railway lines in operation by the various railways.

Banking Facilities

In 1883 there were only fifteen chartered banks in the West, which had grown to seventy-one in 1901, and 822 in 1912, located as follows:

	1883	1901	1912
Manitoba	10	52	196
Saskatchewan	2	19	372
Alberta	3	19	254
	15	71	822

What a marvelous growth, and what a contrast!

I came here, as I have stated before, thirty years ago following the boom. A great many were optimistic and hopeful that with the return of warm weather in the spring, trading in real estate would become more active, but in this they were disappointed. Business depression set in all over the country, and there was great discontent. A good deal of the grain was frozen, and unsaleable, and as the farmers hadn't stock to feed it to, they had to allow it to rot or burn it. The half-breeds and Indians, who counted the Western domain their rightful possession, had been driven back farther into the interior by the incoming of the white settlers, and this invasion and the usurpation of their rights and possessions was strongly resented, and finally resulted in rebellion in 1885, when under the leadership of Louis Riel, the Indians and half-breeds took up arms and attempted to defend their rights, and many of you have read of the Battle of Batoche which took place north of Saskatoon (which today is a thriving city), when the half-breeds and Indians took as prisoners many of the white residents, and looted their possessions, and the whole Western militia, aided by several detachments from Eastern Canada

(about 8,000 in all), were sent forward to Duck Lake, to quell the rebellion which lasted approximately three months. Many of the white people moved out of the country altogether, believing it an unfit place for them to live in, and the farmers owing to the limited branch lines of railway throughout the country were obliged to team their grain from ten to one hundred miles north to find a market for it; and I know it to be an actual fact that some farmers would start out on a Monday morning with probably sixty bushels of wheat, and would have to go a hundred miles to convert it into money, and this trip would require practically the whole week, and the expense of making it did not leave much of anything to buy the necessities of life with.

Therefore you cannot wonder at the discontent in those days. The very best cultivated farm lands in Manitoba could be bought for \$8 an acre, and the uncultivated for \$5; while in Saskatchewan and Alberta, the very best virgin land could be bought at \$1 to \$3 per acre; and with a succession of bad and frozen crops, low prices, can you wonder at the discontent, and the farmers were disinclined to cultivate larger areas, as they found it unprofitable to do so because of the lack of market facilities.

In those days the railway rates on all kinds of freight were exorbitant, and the people of the West for a time were powerless to free themselves from the bondage of these high rates.



Ask the laborer in the field, at the forge or in the mine; ask the patient, delicate-fingered artisan, or the strong-armed fiery-hearted worker in bronze and in marble and with the colors of light; and none of these who are true workmen will ever tell you that they have found the law of heaven an unkind one—that in the sweat of their face they should eat bread till they return to the ground; nor that they ever found it an unrewarded obedience if, indeed, it was rendered faithfully to the command, "Whatsoever thy hand findeth to do, do it with thy might."

John Ruskin



In manual toil, in commerce, in education, and in public service, at home, at the council board, in the church, there is not a bit of routine you can put your hand to but the saints and the heroes were at the beginning of it. "Princes dug this well, yea the nobles of the people hollowed it with their sceptres and with their staves."

George Adam Smith

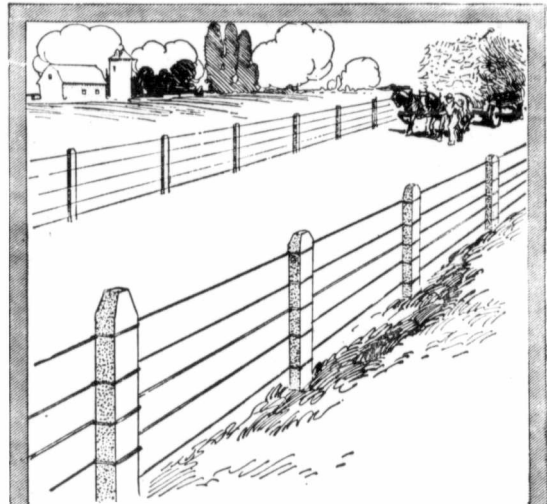

How Much of Your Road Money is Spent in Filling Ruts?

IF the millions of dollars that have been spent repairing worn-out, washed-out streets and roads had been used to build more miles of good highways, fewer farmers would now be wasting valuable time and money taking "round-about" routes to town.

FIRST cost of an ordinary dirt or macadam road is usually only a "starter." The cost of upkeep soon equals that first cost and there is always an ever-increasing annual expense for repairs. The worst feature of it is that such a road is never a really first-class highway.

IN estimating the cost of a road you should include the expense of keeping it in good condition for at least twenty years. If you don't, you're figuring on the first payment for that road, only. And the remaining payments are as certain as taxes. The upkeep cost of concrete roads is practically nothing.

Concrete roads are the best roads from the first—and the best and cheapest roads at the end of ten, fifteen and twenty years.

CONCRETE is the ideal paving material for streets in small towns as well as for main highways in the country.

Edward N. Hines, Wayne County, Michigan, Road Commissioner, and one of America's foremost authorities on good roads, says:

Any community that wants a good road, a road that is cheaper for even a short time under fairly heavy traffic than any other good road, a road that is inexpensively maintained, a road that is sanitary and dustless, a road that is not slippery, a road that affords good traction for any type of vehicle 365 days in the year, a road that in the long run, say 10, 15, 20 years and longer, is the cheapest of all good roads, should investigate the merits of concrete.

WRITE for the facts about Concrete highways. When convinced, use your influence to have the roads for which you pay built to last.

We have highway experts who will visit any community intending to build more roads and explain just why and how concrete roads are best and cheapest.

Canada Cement Company Limited

501-Herald Building, Montreal

550

Have you a copy of our big free book for farmers? "What the Farmer can do with Concrete?" If not, write for it. It's absolutely free.

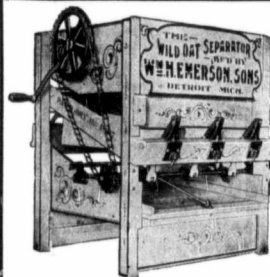

WILD OAT SEPARATOR

We positively guarantee our Separator to remove EVERY KERNEL of Wild or Tame Oats from your SEED WHEAT and NO WHEAT LOST with the oats.

Perfect Separation of OATS from BARLEY or RYE for Seed.

Made in Three Sizes:
6-Shoe Power Separator
3-Shoe Hand Separator
1-Shoe Elevator Wheat Tester

Factories: Detroit, Michigan and Windsor, Ontario
Write for Circular fully explaining this wonderful Separator

WM. H. EMERSON & SONS

81 Commercial Street

Detroit, Michigan



Glancing over January markets one has to notice that during that month wheat was steadier than throughout any other month of this crop year. An oversold position probably accounted for the mid-month rise, while the advance in the last few days resulted from fear of cold weather damage in the winter wheat belt.

Inspections to January 31st are large, totalling:

- Wheat94,304,250 bushels
- Oats30,357,600 bushels
- Barley 9,621,300 bushels
- Flax10,642,800 bushels

The percentage of tough and damp grain has been large, due to winter threshing, but this flow of off-grade grain will likely let up somewhat now. Strenuous endeavors should be made to market off-grade grain now.

The Argentine movement has been retarded, and is unusually late. Estimates of exportable surplus range around 148,000,000 bushels. As the Continent has recently required much high grade with which to blend off her own low grades, European buyers have booked large Argentine shipments of higher grades for February-March delivery. A poorer export demand than usual with us has resulted. It must not be overlooked that the United States has been exporting both wheat and flour in vast quantities, all this practically taking the place our exportable surplus has filled in past years. American millers claim they are well supplied at present in their wheat needs, and the excessive accumulation of flour shipments at ocean ports suggests that bakers and jobbers, who own these shipments, will not necessarily have to actively purchase for a little time. These are "bearish" features, but the season for winter wheat crop scares is almost at hand, and the Short Interest is timid. Australia has just harvested a good crop.

The world's estimate for 1912 crops show a surplus of some 150,000,000 bushels of wheat over that of 1911, but the consumptive demand has been broader, and the first half of a crop year being now over, when naturally the flow is heaviest, it follows that we are now entering upon the period when World's reserves dwindle.

Our domestic situation has been healthy. The Canadian Terminal

Elevators are not yet filled, and very probably the C.P.R. and G.T.P. at least will be able to continue, right through, accepting shipments to Fort William. For a time, till new elevator space is ready, C.N.R. shipments must be routed to Duluth. The all-rail movement East started late, but relatively has been heavier than last season, but Eastern milling demand is said to be "slow."

The spread on tough grain at Port Arthur terminals has widened somewhat, as in a few weeks such grain will be dried at the holders' expense, it being impossible to get it shipped all-rail from such terminals.

The European political embroglio and winter wheat damage will be the two greatest factors influencing the market for February. Continuation of the war (now unlikely) or crop damage would cause some rally, but lacking both or either of these incentives to higher prices, wheat will probably work in small fluctuations, keeping closely adjusted to foreign quotations, and with absence of a speculative element.

OATS

Stocks of this grain continue to increase, and shipments have been heavy. There is little prospect of better prices while the big corn crop in the United States continues to move in such volume. Many farmers will find their tough oats will spoil in April and May unless shipped sooner. The drying capacity of our own and Duluth terminals will again be severely taxed this spring to care for off grades.

BARLEY

The demand has been fair, with small fluctuations, and will likely improve. Farmers in both the U.S.A. and Canada are finding that this crop pays the best this year, but should beware of flooding the market next year, as they did this year with flax after the high prices of the last two seasons. By all means get the tough barley out before mild weather comes. While there is no option market in barley, opening-of-navigational quotations are two to three cents over present prices.

FLAX

Indications are that the bulk of the flax is out of the farmers' hands, and now we may expect the big Eastern crushers to

FARMERS! SHIP YOUR GRAIN

TO THE

CANADIAN ELEVATOR CO. LTD.
GRAIN COMMISSION MERCHANTS, WINNIPEG

It is as much our business to give satisfaction as to secure grain shipments. We watch the grading of each car and allow liberal advances on all bills of lading.

You saw this advertisement in this magazine. Don't forget to say so when writing.

Donald Morrison & Co.

ESTABLISHED 1904

GRAIN COMMISSION

**711 T Grain Exchange
WINNIPEG**

WE handle Wheat, Oats, Flax and Barley on commission, obtaining best possible grades and prices. Our work is prompt, accurate and reliable. Let us handle YOUR shipments this season. Daily or weekly market letter on application.

REFERENCES: Bank of Toronto, Northern Crown Bank and Commercial Agencies.

You saw this advertisement in this magazine. Don't forget to say so when writing.

More Good Advice to Grain Growers FROM McBEAN BROS.

WE issued a circular letter about six weeks ago advising farmers to hold their grain. Since then we have had an advance of from 5c to 10c per bushel on wheat—the low grades advancing the most. We still expect to see a further advance in the price of wheat, oats, barley and flaxseed, but it is most likely that we will have very strong, sharp reactions from time to time, that might discourage many holders of grain. We still advise farmers who have carloads of grain to ship to order cars at once, load them when they are ready, bill them forward to either Fort William, Port Arthur, Duluth or Superior, whichever place the railway company will take them. Don't miss getting your grain shipped when you get the chance, after shipping do not offer your grain for sale until the car is unloaded and the out turns back to the commission agent, and even then it may prove best to hold in store for a while. Load the grain, whenever possible, direct from the wagon into the car. If farmers adopt this method of shipping and marketing grain, we venture to say it will mean fully \$100 per car lot extra money for his net returns.

Write us for shipping instructions, market card giving prices, and also market prospect letter which gives our reasons for expecting the price of grain to advance. Do not listen to the

prattle and advice others give that are contrary to the advice we give. We are in this business to stay, and to hold farmers' business with us from year to year, we must give as true and accurate advice as we possibly can offer them. We have had around thirty years' experience in this Western Canadian grain business and we ought to know just what we are talking about, and we say again, don't be influenced to have your car lots of grain handled in any other way.

We understand that the elevators at Port Arthur are filled and the Canadian Northern Railway Co. will not take grain to Port Arthur, but they will take it to Duluth or Superior. When your grain is loaded and billed forward, send the shipping bill to us. Our facilities for handling grain shipped to either Duluth or Superior are equally as good as if shipped to either Fort William or Port Arthur. There is no difference between storing in Duluth or Superior—one place is equal to the other.

We are bulls on grain—wheat, oats, barley and flaxseed at below the present level. If you want your grain handled by an experienced and honest grain firm, which knows HOW and WHEN to sell on bulges and avoid selling on declines, ship to the old established firm of McBEAN BROS.—established in 1882 and still at it.

McBEAN BROS.
Grain Exchange

WINNIPEG

:: ::

MANITOBA

Consign your Grain to a firm that will look after your interests: call for re-inspection when necessary — obtain highest market prices, and make prompt returns:

Central Grain Company Limited
Bona fide COMMISSION MERCHANTS Licensed

707 Grain Exchange - Winnipeg, Man.

Car Tracin' and Claim Department in connection. Send us samples of your Grain, we will look after the grading and advise you promptly. The permanent success of our business depends on our customers' continued satisfaction.

Paid-up Capital: \$150,000

References—Any Bank or Commercial Agency

You saw this advertisement in this magazine. Don't forget to say so when writing.

Farmers! Ship Your Grain Direct

We are prepared to handle all kinds of grain in carloads direct from farmer to Eastern markets. Farmers may draw on us for high percentage of value, bill of lading attached. No delay in final returns. Reference: Sterling Bank of Canada. Full particulars furnished promptly.

Canada Grain Co. Ltd., Toronto

You saw this advertisement in this magazine. Don't forget to say so when writing.

gradually lift the price of flax so that they may sell their oil. Except off-grade flax, farmers need be in no great hurry to market the rest of their flax. The market here is in strong hands, but can be likely caused to fluctuate according to their pleasure.



Gasoline Traction Engines

Continued from page 18

gear, and left me helpless. I had to jack the engine up level to the ground, and get a large steam engine to pull me out on to dry land. Oh, the work and worry of it all!

I pulled out of that on to a higher quarter-section, and made very good time there for 30 or 40 acres, which was all there was fit to break with my outfit, as the rest were old bluffs and stumps, etc.

I decided then to pull home and did very well for about a week or ten days, when it came on very wet again.

To sum up, I plowed about 100 acres in the spring, and broke about 125 acres during the summer. I just did my own threshing last fall, and plowed about 25 acres between times. It has all been expensive plowing work, as the season was so wet. I use about 40 gallons of kerosene in an eight-hour day, and about 20 gallons of water.

I have one team and two men with the outfit, and it costs me \$1.00 per acre to plow stubble and considerably more for breaking.

I have done no discing, seeding, and only plowing. I don't think an engine is detrimental to plowed land. I was afraid last spring that it would be as it was so wet, but I could not see any difference in harvest time, where the tractor had been, and where it had not.

In conclusion I must say I believe there are times and conditions under which a tractor can be used very much to advantage, but my experience during the past season has taught me that it would be folly to depend altogether upon the tractor in this district anyhow, so I have decided to keep my horses to push the work when it is not fit for a tractor, and use the engine when it can be used to advantage.

Yours truly,
W. E. Martin,
Saltcoats, Sask.

February 1, 1913.



Canadian Bank of Commerce

Continued from page 73

the food consumers out of a proportion to the food producers, and it is pleasing to see some slight evidence of a return to the land which may help to correct this disproportion, but while the quantity of fruit, vegetables and cereals grown may immediately be increased so as to affect prices, the state of the cattle industry of North America is so serious that some years must pass before we may hope for a return of normal con-

We Lead the Way in Pedigreed Seed Grain

GARTON'S EARLY NO. 46 WHEAT (REGENERATED)

Bred by Garton Brothers, the celebrated Farm Plant Breeders, England.
The earliest, heavy yielding and most rust-resisting strain of wheat.

NO. 22 OATS

Bred by Garton Brothers by crossing together Abundance, Banner and Tartar King. The earliest, large-grained, strong-strawed oat in cultivation. Six days earlier than Abundance.

GARTON'S NO. 68 SIX - ROWED BARLEY

The earliest six-rowed barley out of a test of 134 trial lots.

Breeders and original introducers of No. 46 Wheat, Regenerated Abundance, Regenerated Banner Oats, Brewer Barley and Selected Strains of Grass, Clover and Root Seeds. Write for Catalogue (now in press describing fully all the above varieties of grains and seeds.

MARQUIS WHEAT

Bred by Dr. Saunders, the famous Plant Breeder of Ottawa.

Has proved an ideal wheat for western conditions. Our seed is raised from stock seed obtained from Indian Head Experimental Farm.

BLACK VICTOR OATS

The heaviest yielding Black Oat in cultivation. 47% more feeding value than any White Oat.

GARTON'S SELECTED HARDY ALFALFA

Proved by five years' trials to be the Hardest Strain in the West.

GARTON PEDIGREE SEED CO., Ltd.

Seed Farm 2480 Acres, CAREY, MANITOBA

259 Chambers of Commerce, WINNIPEG

Steady Markets. Demand Good

Undoubtedly the farmers who did not sell on street in December, but consigned and sold in January, saved several cents per bushel. The same will likely be the case on February consignments. We can handle Duluth or Superior shipments equally as well. Farmers try our service, and you will be convinced that experience and hustle can mean much to you.

BLACKBURN & MILLS (A. M. Blackburn) (D. K. Mills)

531 Grain Exchange Winnipeg, Man. Telephone Main 46

Licensed Reference: The Royal Bank of Canada Bonded

You saw this advertisement in this magazine. Don't forget to say so when writing.

ditions. It looks as if the United States would soon cease to export beef, and unless we at once change our course we may be in a similar condition. We must increase the number of beef cattle, sheep and swine on the land very largely if our annual consumption is to be supplied without depleting the herds. We shall hope the Commission regarding our cattle ranges will produce good results, and that the assurance of high prices for meat for some time to come may induce mixed farming to a degree not yet accomplished. Since 1908, while there has been a small increase in the number of horses in Canada, there has been a serious decline in the number of milch cows, beef cattle, sheep and swine. There should have been a very large increase and unless every possible effort to arrest the decrease is made, this class of food will grow steadily dearer in price. The falling off is most noticeable in Ontario, where the only important gains are in Saskatchewan and Alberta.

The Clearing House statements again give ample evidence of our rapid growth. The returns of twenty Clearing Houses for 1911 made a total of \$7,391,368,000, while for 1912 the figures were \$9,146,236,000, a gain of 23.74 per cent. Once more we have to record a gain in every Clearing House in Canada.

The building permits of the four chief cities were as follows:

	1911	1912
Montreal	\$14,580,000	\$19,642,000
Toronto	24,374,000	27,401,000
Winnipeg	17,550,000	20,475,000
Vancouver	17,652,000	19,388,000

The Silent Man

Judge Rinktum makes no foolish breaks, no blunders, bad or shocking; he goes his way day after day, and no one hears him talking. He answers "No" in accents low when some one asks a question, or murmurs "Yes," as in distress from verbal indiges-

tion. He won't debate, he won't orate, or break his solemn quiet; he shakes his head—all has been said—he wants no wordy riot. So in the town he has renown as being crammed with knowledge; his bunch of brains more lore contains than Yale or Harvard college. We're proud of him, this jurist grim, this man who never chatters; the referee and umpire he in all our village matters. The dames are proud when he has bowed in stately recognition; if Rinktum stands and shakes your hands, he betters your condition. Yet this old boy, our pride and

joy, whom some consider greater than Cicero or G. Pinchot, is but a selling plater. If he should drain his massive brain and take out all that's in it, he wouldn't need to do the deed, much more than half a minute. Oh, just look wise and you will rise and have good things before you; but talk too much and you're in Dutch, and no one will adore you.

It easeth some, though none it ever cured.
To think their colour others have endured.—Shakespeare.

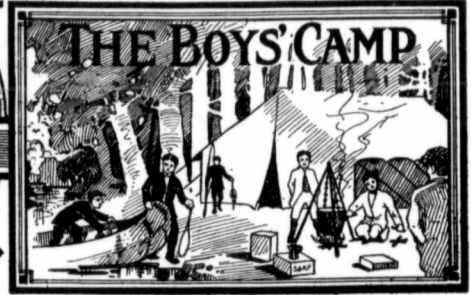

Girls' Cozy Corner

The Fairies' Shopping

Where do you think the Fairies go
To buy their blankets ere the snow?

When Autumn comes with frosty days,
The sorry shivering little Fays

Begin to think 'tis time to creep
Down in their caves for Winter sleep.

But first they come from far and near
To buy, where shops are not too dear.

(The wind and frost bring prices down,
So Fall's their time to come to town!)

Where on the hillside rough and steep,
Browse all day long the cows and sheep,

The mullein's yellow candles burn
Over the heads of dry sweet fern:

All summer long the mullein weaves
His soft and thick and woolly leaves.

Warmer blankets were never seen
Than those broad leaves of fuzzy green.

(The cost of each is but a shekel
Made from the gold of honeysuckle!)

To buy their sheets and fine white lace
(With which to trim a pillow-case).

They only have to go next door,
Where stands a sleek brown spider's
store.

And there they find the misty threads
Ready to cut into sheets and spreads.

Then for a pillow pluck with care
Some soft-winged seeds as light as air;

Just what they want the thistle brings,
But thistles are such surly things—

And so, though it is somewhat high,
The clematis the Fairies buy.

The only bedstead that they need
Are silky pods of ripe milk-weed.

With hangings of the dearest things—
Autumn leaves, or butterfly wings!

And dandelions' fuzzy heads
They use to stuff their feather beds;

And yellow snapdragons supply
The nightcaps that the Fairies buy.

To which some blades of grass they pin,
And tie them 'neath each little chin.

Then, shopping done, the Fairies cry,
"Our Summer's gone! O sweet, good-
bye!"

And sadly to their caves they go,
To hide away from Winter's snow—

And then, though winds and storms may
beat,
The Fairies' sleep is warm and sweet!

—Margaret Deland

Girls' Prize Letter

Quill Lake, Sask.

Dear Cousin Doris: I am a silent reader of your most interesting page, and now have taken the courage to write. Cousin Doris, I think your monthly chats are lovely, also the letters from the members.

My two brothers take the Canadian Thresherman and Farmer, and take great interest in it.

We live six miles from the town of Quill Lake, but only a mile or over from the lake. The lake is a very large one.

We have three cows and one calf, eighteen horses and 4 colts, also one large pig and eight little ones. The pigs are red. They are so cute.

Cousin Doris told us to tell about our experiences, or, rather, what we have done and are doing.

At present I am staying home from school helping Mamma, as she it not very well. I wash dishes, sweep the floors and sometimes wash a towel or so. About sewing, I do not do very much except for my doll, and lately I sewed an apron for myself on the sewing machine. It certainly does not look very good. I think that I will have to get instructions in putting the band on next time.

I am in the fifth grade at school. My studies are arithmetic, reading, spelling, geography, history, penmanship, drawing and composition. Reading, spelling and geography are my favorite studies. I tell Mamma that history is only names and dates. Do you not agree with me, Cousins?

How many of your girls intend to be teachers, when you get big? I do for one. I also intend to be a dressmaker and music teacher. I think I shall like such work.

I like fancy work quite well and have crocheted a doll's scarf, and am learning to embroider by starting on a pin-cushion.

I hope, dear Cousin Doris, that you and your little girl are well and happy. I have a dear little nephew that is two years old. He is so cute. I wonder how he and your little girl would get along together. Is not your little girl's name Monona?

Oh! This is such a long letter, now I must stop as I am afraid you will throw it in the waste basket long before you get through. Please excuse the mistakes in it. I am, your loving Cousin,

Inez M. Torell.

Aylesbury, Sask.

Dear Cousin Doris,—This is my first letter to your club. I thought I would like to write. I never write. I am in the IV. grade at school. My studies are reading, writing, spelling, geography, history, grammar. My favorite studies are reading and spelling. I would like to correspond with any of the girls. I am 12 years old. My father takes the Canadian Thresherman. I like to go to school. I like reading the letters in the Girls' Cozy Corner. My mother and brother went to Aylesbury for a holiday. I would like to receive a book. I live four miles east of Aylesbury. Wishing Cousin Doris success. — Hazel Harrop.

Girls' Prize Letter

Gilbert Plains, Man.

Dear Cousin Doris,—This is my first letter to the Girls' Cozy Corner. My father takes the Canadian Thresherman and Farmer. We like it fine. My parents came from Dauphin nine years ago. I am eleven years old in October. We live in Gilbert Plains now; we moved about two years ago. I have one sister; her name is May. For pets I have a little white and black pup and big black dog named Honey. I go to school every day. There are forty pupils. We have 90 hens and two geese and five ducks. Well, I had better close for this time. Wishing the club every success. Hoping to see my letter in print.—Eva E. Wilson.

Arcola, Sask.

Dear Cousin Doris,—This is my first letter to 'he girls' cozy corner. I like reading the girls' letters. I have five brothers and one sister. I am ten years old. I have to walk three miles to school. I have been going to school three years now. I am going to ride next summer. Well, I must close now. Wishing to see my letter in the Canadian Thresherman and Farmer, I am, yours truly,—Esther Butt.

Bardo, Alta.

Dear Cousin Doris: This is my first letter to the Girls' Cozy Corner. My brother takes the Canadian Thresherman and Farmer and I find very interesting in reading all the letters the girls and boys write, so I thought I would try to win a prize too, as I see the other girls do. I am 14 years of age and am in grade eight but the last year I have not been going to school because I live on a farm and have a lot of work to do.

We have about one hundred chickens, eighteen pigs, twelve sheep, twenty-seven horses, and fifty-seven head of cattle and now I have a duck and a pair of turkeys, so I am going to try to raise some if I have any luck. Last year I helped to plow and I harrowed over one hundred acres in all, and in haying I raked all the hay we put up because I don't care what I do as long as I can handle them. My brother and one of our neighbors bought a threshing outfit last spring, and have been threshing all summer, till late fall, but now my brother runs the stationary engine in Mackenzie's coal mine, at Dodd's Station, about 4 miles South-east of where we live, and then we have Round Hill, straight South; Kingman, seven miles South-West; Tofield nine and a half miles north, and Ryley, nine miles north-East, so we are encircled by railroads. It is a nice farm. We have it handy for water; we have one well in the barn and one at the house; and overlasting water too, but papa wants to sell now, as soon as there come a buyer. Two of my uncles have taken their homesteads up at Grand Prairie and many others of our relatives. Well, we have a very nice winter, because there is not even an half-inch of snow, so it has been a splendid one. I guess I must quit now to leave room for the others, hoping to see my letter in print, I remain, yours truly,

Signora Lerhecknis.

Send your Raw FURS to John Hallam

Sixty Thousand trappers now send us their Raw Furs. Why not you? We pay highest prices and express charges, charge no commission and send money same day goods are received. Millions of dollars are paid trappers each year. Deal with a reliable house. We are the largest in our line in Canada.

FREE Our "Up to the minute" Fur quotations and the last Edition of **HALLAM'S TRAPPERS GUIDE**, a book of 90 pages, mailed **FREE**.

Write to-day to John Hallam, Mail Dept 44 TORONTO, 111 Front St. E.

Mention this magazine when writing advertisers

SEND 1 DOLLAR

Receive by return mail post paid Two pretty Fall and Winter Dresses for little girls age 1 to 10. Material is soft warm goods for winter wear in checks and stripes in various pretty colorings made just as pictured. Add 15c for postage. Order at once.

Standard Garment Co.

17 Standard Building, London, Ont.

Mention this magazine when writing advertisers

NO MORE WET OR COLD FEET!!

Try a Pair of our famous (Health Brand) **FELT-LINED CLOGS**

as illustration, leather tops, wooden soles, lined felt. Men's or Women.

ONLY \$1.60

Express prepaid to your home, on receipt of money order or cash (no checks)

Higher 3 buckles \$2.25
High legged Wellingtons \$2.75 & 3.25
Low cut \$1.25

CANADIAN FELT-LINED CLOG CO.,
Dept. A, 363 Spadina Ave., Toronto, Canada

Mention this magazine when writing advertisers

Canadian Boys' Camp

Prize Letter

Bedford, Man.

Dear Cousin Doris: I have many play mates in this place. My sister comes in the bush and chops piles of wood for me. My dog comes with me too; he is very faithful. He catches squirrels and eats them. I have two axes. I cannot write very well yet. My mother taught me to write. I have only been to school for one year.

I remain,
Yours truly,
(Age 7) Russell White.

Shusherville, Dec. 3, 1912.

Dear Canadian Camp:

This is my first letter to your camp. I have four sisters and three brothers. We have a farm and a ranch. My two sisters and I live on the farm, and my

father, mother and three brothers and two sisters live on the ranch. My father takes the Canadian Thresherman and Farmer. Our ranch is about forty miles from the nearest post office, and our farm is two miles from the post office. On the ranch we have about 30 cattle and I think 33 horses and on the farm we have two cows, two pigs and about 80 chickens and a house. I will close wishing to see my letter in print.

I remain,
Arthur White.

Oak Lake, Man.
Dec. 23rd, 1912.

Dear Cousin Doris:

This is my second letter to your club. I received my book a week ago and like it very much, it is my first Christmas gift. I have read a lot of books. Here are a few names: "Bob Burton," "Joe's Luck," "Paul, the Pedlar," "Fertil, the Fiddler," "Slow and sure," "Tom, the boot black," "Saved by the life-boat," "Herbert Carter's Legacy." This is all the names I can think of just now.

We have a calf two weeks old; it is grey, with a red head and neck. I go to a French school now. I am in the fourth class; my studies are arithmetic, spelling, history notes, grammar and geography, but I don't like history notes, for I have to learn it by heart.

Well, I must close, hoping to see this letter in print, wishing this letter jumps the W.P.B.

Wishing you a Merry Xmas and a Happy New Year.

Yours affectionately,
Harold Robins.

Carmagna, British Columbia.

Dear Cousin Doris:

This is my first letter to your club. I have been a member of many clubs, but I think this one is the best.

I have been taking the Canadian Thresherman and Farmer and like it very much.

As soon as I get the magazine I look for the Girls' Cozy Corner. I have always resolved to write to help the boy's page out.

I do not see many boys writing so I thought I would write and help them out.

We have a small farm up here, we have one mare and a two-year-old colt and two cows, two calves and a year and a half old bull, and a lot of chickens.

I am not going to school now. The Trustees have made arrangements to put our teacher out at Christmas.

I guess I will close with a few riddles. When is a boat not a boat?

Ans. When it is a drift.

Father and mother, sister and brother, ran all day and couldn't catch each other?

Ans. Wagon.

I hope to see my letter in print.
Yours sincerely,
Raymond Camagna.

After the Sand Storm
By M. Gauss

Continued from last month

From time to time the shadow of a cloud crossed the plain; now and then a buzzard sailed by overhead. Lizards darted away from him. Over beside a cañon he saw a tarantula, rolled up like a ball of string. At last the sun stood in the Zenith; it was noon.

He now thought the blue streak looked like a cañon than it did like an outcrop of slate. But his eyes were dimmed and his mind was confused by the heat; so he preferred to depend on his observations of the early morning. He kept steadily toward the place.

He came to an arroyo, and started across it, the dry earth crumbled under his feet. And as he recovered his balance, he heard a pleasant sound.

Although it seemed to come from a distance, it was distinct—a dripping and trickling sound like that of water dropping on stones.

The sound of falling water grew louder, yet there was no moisture in the crevice. He began to believe the stream was a magic one, and that he was still far from it.

The Latest Columbia Hornless Graphophone
The \$45 Value Machine.....

\$26



THE ECLIPSE—Oak \$26, Mahogany \$32.50

Here is the newest musical instrument in the field—a hornless Columbia Graphophone—of-ford at \$26 to those who want the latest improvement in Graphophones and yet who believe \$26 is enough to pay. We will supply on very easy terms if desired. Write for full particulars.

No "hornless talking machine" of any make so far offered at anything like this price, has the Columbia features of the continuous tone chamber, the improved Columbia reproducer, the Columbia tapered tone-arm, the tone-control shutters, faultless and noiseless Columbia motor, nor the musical tone-quality that those Columbia features unite to produce.

The Columbia hornless Graphophone, "Eclipse," is 15 1/2 in. square, beautifully quartered oak; plays any disc record—all the recorded voices of the world's great artists without exception are at your command. Certainly price need no longer deprive you of the endless enjoyment that only a Columbia can bring. The "Eclipse" can be supplied in Mahogany Cabinet at \$32.50.

We have other Columbia models at all prices from \$20 to \$65.00. Complete illustrated list is sent free on application. Old machines of any make taken in exchange.



COLUMBIA RECORDS

Absolutely the best, perfect reproduction, longest wear, will play on any make of disc machine. Insist on having them 30,000 records always in stock. Double side records, two different selections, 85 cents. Specially imported English, Irish and Scotch records. Your old favorite songs. Complete Lists Free.

THE BEST IS THE COLUMBIA

You should hear Caruso, Bonci, Nordica, Tetrazzini, Nielsen, Melba, in Grand Opera; Harry Lauder, Collins and Harlan, Ada Jones, in comic selections; Kubelik, Mischa Elman, Scharwenka, Hoffman, in instrumental pieces, and many other artists on the Columbia Graphophone. You get the finest reproductions. The living voice of the artist. We will supply the "Eclipse" or any Columbia Graphophone, for cash or on very easy terms of payment. Send for full particulars.

CUT OUT THIS COUPON AND MAIL TO US.

WINNIPEG PIANO CO

295 PORTAGE AVE. WINNIPEG.

No. 67.

WINNIPEG PIANO CO., 295 Portage Ave. Winnipeg, Man.

Please send me your new Illustrated Machine Catalog and interesting history of the Graphophone.

I assume no obligation and all you send is to be mailed free.

Name.....
Street.....
City..... Prov.....

You saw this advertisement in this magazine. Don't forget to say so when writing.

Suddenly the arroyo came to an end. But although the earth looked as if it had been dry for centuries, the noise of water was louder than ever.

As he looked about him, he saw the cause of it. Over the edge of the arroyo, with the pebbles clinking musically, ran a tiny river of sand. Joe stared dully at it; then he turned away.

At the head of the arroyo he stumbled over an odd, whitish thing, half-buried in the sand; it was the skeleton of a burro. It lay where the creature had fallen, no doubt, when, on seeing that the stream-bed was wholly dry, it gave up hope.

Joe climbed out of the place and sat down in the shadow of a large rock. He was no longer overheated; he thought that he felt chilly, especially along the spine, towards mid-afternoon; above the western horizon he could see thick, white clouds, edged with gold.

He rose, and stumbled on toward the streak of blue. It seemed to grow no nearer as he walked.

But right before him he saw a cañon—green with the celars that covered its sides; watered by a frothy little stream that raced along a bed of clean pebbles.

Joe clenched his fist, and shook it at the desert. "What do you take me for?" he asked, aloud. "Think I don't know your tricks? Try 'em on a tenderfoot. There's no cañon anywhere near, I tell you." Then he rubbed his dazzled eyes, and the mirage first withdrew toward the horizon, and then disappeared.

As he toiled toward the southwest, hills and rocks began to cast long shadows. It would soon be night again.

Joe's strength was failing. Possibly by morning he would be out of his head from heat and thirst, and would not know what he was doing. He sat down to think.

When Decker told him to sell the steers and bring home the money, another man had said, "Say, Decker, seems to me you trust that kid too far." But Decker had a way of acting on his own judgment of a fellow. "And he trusted me," Joe reflected. Decker had been as kind as a father to him; a hundred times the boy had promised himself that he would someday repay him. And now every one would think—Decker himself would think—that Joe Travis had run away with his benefactor's money.

At this thought he rose, and stumbled a few steps farther. But he could not go on.

An idea occurred to him; he would write a letter. He thought he could convince one that no one except Decker

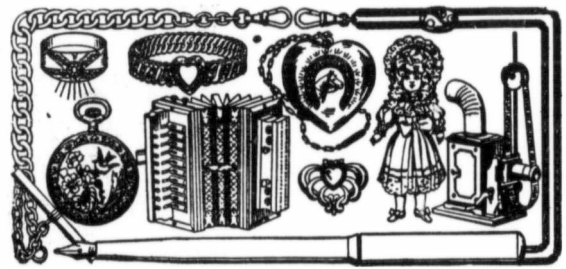

FREE TO YOU. The best premiums and biggest values ever offered. Gold and Silver Watches, Gem set Rings and Brooches, Laughing-producing MOVING PICTURE MACHINES, finely-decorated TEA SETS, SILVERWARE, ACCORDIONS, LOVELY DRESSED BOWLS and many other beautiful premiums given FREE for selling our high-class GOLD SMOKING CARDS at 6 for 10c. Our cards are the very latest designs in FIGURAL, BIRTHDAY, HOLIDAY, VIEWS, COMICS, &c., in artistic colors and of such superior quality that you will have no trouble selling them.

JUST SHOW THEM AND TAKE IN THE MONEY.

You can win any of these splendid premiums by selling \$5.00 worth and upwards, and if you will write to-day you can also win one of the EXTRA PREMIUMS we are giving to those who are prompt. Send us your name and address, plainly written, and we will forward you a package of cards and our big premium list. We get a great many repeat orders from our customers. WHY? BECAUSE OUR PREMIUMS ARE THE BEST. CO-SALT GOLD SEE CO. Dept. Toronto, Ont.

would understand. But the cattleman would be able to find his money, even if months or years should elapse before the finding of the letter.

He remembered that Decker sometimes spoke of money as "silage," just as some people speak of silver as "chicken-feed." Moreover, he had told Joe how he had once hidden some bills under a yucca-plant, and had marked the yucca by tying an old tin can to it.

He wrote with the stub of a blue pencil on a scrap of paper. There were many misspelled words, for he had little education. "I put the silage where you told me you did once," he said to Decker. Then he added the hope that it would be found "in good fix." And as he felt too weak to write more, he signed his name.

He now began looking for a yucca, under which to hide Decker's bills and gold. By some fortunate chance, he stumbled on an old tomato-can that would serve as a marker on the plant. He wondered a little at finding it so far in the desert, and went on, carrying it.

His eyes, dazzled by the long and glaring day, had become exceedingly painful; and he groped with both hands when he saw a plant of some kind before him.

The thing he touched was not yucca, but thim, dry and fragrant. It was cedar and cedar does not grow out on the desert.

The sun dipped behind a cloud. Joe's eyes were relieved, and he looked up. On the crown of a hill, directly in front of him, he saw a ragged edge of green stuff, and that meant that there was a watered cañon beyond. At last he had reached the place that in the morning had appeared to him as a far-away streak of blue.

A breeze brought the smell of evergreen; the ground was very rough. As he climbed the steep incline, he stumbled over sharp pink boulders. Among these a foot-path twisted; some calves, browsing on the slope, lunged awkwardly off. And now, sweet and distant, he heard the supper-horn at some ranch. He pressed on up the hill.

From the summit he looked down into a cañon, and upon a stream that in places was white with alkali, and much trampled by horses and cattle. The sun was setting. There was a red light on wet fields and gardens, on the water in the irrigating ditches. He saw a milk-house, a windmill, some long, low alkali ranch buildings. He had come out at Running Water ranch.

A man rode along the stream, and started to splash through. He lifted his eyes. "Why, it's Joe," he shouted. And Joe laid one hand on the belt in which the money had been faithfully kept, and waved the other to Decker.



Womans' Department
Conducted by PEARL RICHMOND HAMILTON

A HOUSEHOLD FORUM FOR THE DISCUSSION OF EVERYTHING THAT PERTAINS TO THE HOME



The House by the Side of the Road
 By Sam Waller Foss

There are hermit souls that live withdrawn
 In the peace of their self-content;
 There are souls, like stars, that dwell apart
 In a fellowless firmament.
 There are pioneer souls that blaze their paths
 Where the highways never ran—
 But let me live by the side of the road,
 And be a friend to man.

Let me live in a house by the side of the road,
 Where the race of men go by—
 The men who are good and the men who are bad,
 As good as bad as I,
 I would not sit in the scorners' seat,
 Nor hurl the cynic's ban—
 Let me live in a house by the side of the road,
 And be a friend to man.

I see from my house by the side of the road
 By the side of the highway of life,
 The men who press with the ardor of hope,
 The men who faint with strife,
 But I turn not away from their smiles
 Nor their tears—
 Both parts of an infinite plan—
 Let me live in a house by the side of the road,
 And be a friend to man.

I know there are brook-gladdened meadows ahead,
 And mountain of wearisome height;
 And the road passes on through the long afternoon,
 And stretches away to the night,
 But still I rejoice when the travellers rejoice,
 And weep with the strangers that moan,
 Nor live in my house by the side of the road,
 Like a man who dwells alone.

Let me live in my house by the side of the road,
 Where the race of men go by—
 They are good, they are bad, they are weak, they are strong,
 Wise, foolish—so am I,
 Then why should I sit in the scorners' seat
 ●●● hurl the cynic's ban?
 Let me live in my house by the side of the road,
 And be a friend to man.

A Word to Western Women

The Young Women's Christian Association

During the past seven years I have been very greatly interested in the young women of Western Canada, and owing to several experiences I have had with girls coming in to this city from rural homes, I feel that some information regarding the Young Women's Christian Association will be helpful to our girls as well as to our mothers.

I will mention the department of the work which is most useful to young women living in the outlying districts. The Young Women's Christian Association is a world-wide organization, and has half a million members. Its having associations in every continent, in every walk of life, an opportunity purpose is to give to all young women through the various departments to develop her physically, intellectually, spiritually and socially. It aims to give such a physical development as shall fit young women everywhere for the wear and tear of life; to give such a social life as shall cause them to value the true worth of character wherever found; to give such an intellectual life

invites young women throughout the country who contemplate going to any of these centres to communicate with them in order that the association may be of assistance in meeting them at the train, finding them comfortable boarding houses, and in obtaining suitable positions. The Travellers' Aid agents meet all trains, each agent wearing a badge of enamel, on which is engraved the letters Y. W. C. A. Any girl can feel perfectly safe in accepting any information or following any directions the Travellers' Aid agent may give. Last year in the city of Winnipeg three agents were engaged in the work of meeting trains—4,321 trains were met, and assistance given to 2,874

The stranger replied: "Your brother is ill and sent me to meet you in his place."
 The girl was just ready to go with him when she was rescued by a woman who had listened to the white slave villain.
 There are many dangers for unprotected and inexperienced young women who travel. Young women are warned to accept no offers of help from men or women who are unknown to them and not to go to any address given to them by strangers. The objects of such persons may be to entice young girls to their ruin.
 A young girl of my acquaintance stopped at the station between trains. She went out to buy some postage stamps. At the place where she bought her stamps a young man stepped up and asked her if she were a stranger. When she answered she was, he handed her a card saying: "Here is the address of a good inexpensive boarding house."
 The girl took the card, but one her way back to the station another man followed her and asked her for the card. This man was a private detective. He read the card and said to the girl: "My girl, if you go to this address you will be ruined."

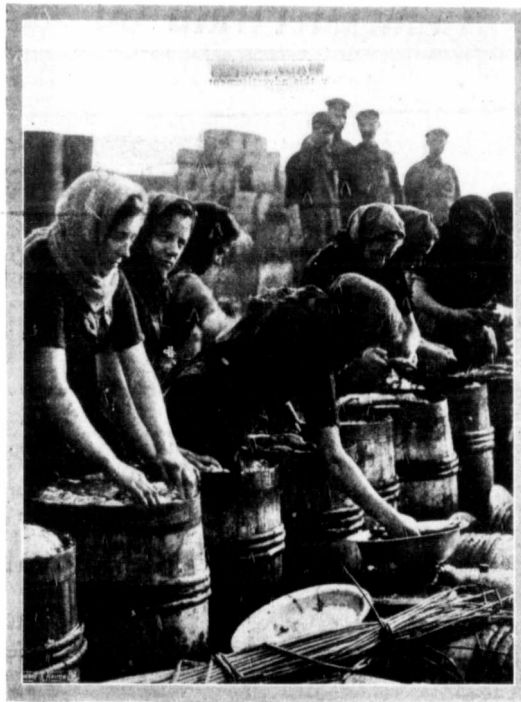

WOMEN WHO TOIL
 Highland Lassies Packing Herrings for the Foreign Market

as shall give them to some degree self-sufficiency and make them value a good place at house work over a poor place in a factory or shop; to give them such spiritual life as shall bring them into God's plan for the universe as His children. This no less is the aim of the association for all young women. The growth of the association work in the Dominion of Canada has been marvelous in the last few years. There are today thirty-three associations, thirty-one student, and four schoolgirl branches, with a total membership of 13,300. In Western Canada there are associations at Winnipeg, Brandon, Saskatoon, Prince Albert, Regina, Moose Jaw, Calgary, Edmonton, Vancouver and Victoria. The association at each of these points

women and girls to boarding houses, hotels, hospitals and various other places. It is not safe for young girls to travel alone unless they seek the aid of these Travellers' Aid women. I know of several cases where through their shrewd watching over a girl stopping between trains, they prevented the girl from falling into the hands of white slave agents. A girl once came into the city and expected to be met by her brother. Through a mistake her brother was not at the station. A white slaver can spot a strange girl alone immediately, and so one stepped up and asked her if she were looking for some one. "Yes," she replied, "I am looking for my brother—he promised to meet me."

Every girl who contemplates going to a city should write to the General Secretary of the Y. W. C. A. for directions to be met by a Y. W. C. A. Travellers' Aid agent. If a girl intends coming to Winnipeg—Miss Nellie Elliott, General Secretary of Y. W. C. A. in Winnipeg, will give her helpful and safe directions. Girls write to me from the Old Country asking how they may be safely directed at their changing places. If a girl writes to the General Secretary of the Y. W. C. A. in any city the general secretary will give her the name of the Travellers' Aid Agents who will meet her at the trains. A girl should give a minute description of herself and the time of arrival of her train.
 Not long ago one of our readers wrote me saying she had sent a young girl into the city, and wanted me to meet her at seven o'clock in the morning. As that was before daylight, I could not go. I went to Miss Elliott of the Y. W. C. A. and she very kindly told the Traveller's Aid agent to meet her, which she did, and brought her to the Y. W. C. A.
 The Y. W. C. A. of Canada, saves hundreds of Canadian and Old Country girls every year in just this way.
 Just a word in regard to the opportunities offered by the Y. W. C. A. homes. There are classes in the association building that cover all kinds of educational work that a girl needs. The class fees are very reasonable. There are Bible classes conducted by such capable and sympathetic teachers as Miss R. Rodgers and Miss E. Grace Brooking. Miss Brooking does a great amount of good, speaking in the factories of Winnipeg. The girls all love her and her reward will be the salvation of a great number of girls.
 A teacher's training course is conducted by Dr. W. A. McIntyre, Winnipeg's leading educational instructor. Then, there are courses in stenography, English, arithmetic, reading, grammar, French, German, elocution, music, domestic art, including embroidery, millinery and sewing. There are art classes in drawing, water color and oil painting, and china painting.
 A splendid course in domestic science, under Miss Marie A. Peck, is largely attended.



MOONEY'S BISCUITS

BISCUITS MUST BE FRESH TO BE PALATABLE

MOONEY'S BISCUITS ARE THE FRESH BISCUITS

Fresh enough to take the place of the bread and biscuits you bake yourself. Because the **MOONEY** system is so perfect that every biscuit is shipped the same day it leaves the oven.

The big Winnipeg factory is so close that your grocer gets **MOONEY'S** in a few hours—no long haul—no deterioration.

Besides the demand for **MOONEY'S**—the popular biscuit—is so great that his stock is always changing.

MOONEY'S never grow stale on the grocers' shelves, That's one reason why

MOONEY'S PERFECTION SODA BISCUITS

are fresher, crisper and more appetizing.

Ask for the big package or a sealed tin and judge for yourself.



You saw this advertisement in this magazine. Don't forget to say so when writing.

The president of the Winnipeg Branch is Mrs. Edward Brown. Miss Nellie Elliott is the General Secretary, and she is the right young woman in the right place, for she is sympathetic, kind, and very capable. She has the dignity necessary for an executive leader, yet she is approachable. Any girl who is in the atmosphere of her personality must feel inspired by honest womanly ambitions. The Winnipeg Y. W. C. A. must be a great power for good when it is under the management of a woman like Miss Elliott. The Y. W. C. A. in every city of Canada should have the sympathy and support of our Canadian men and women, for this institution is making a better womanhood, and the universal craving of every nation is for a clean, pure womanhood.

The following prayer for young women is one I would write on the heart of every woman and girl in Canada:

"Keep my mental home a sacred place, golden with gratitude, redolent with love, and white with purity. Let me send no thought into the world that will not bless, or cheer, or purify, or heal."

P. R. H.

Mothers' Corner

GOOD NIGHT TO MOTHER

From Mother's Magazine

In the city of Boston is an old lady whose "baby" is sixty-five years old, while the old lady herself is a wonderfully alert woman of ninety years. She has always had that dear delight of an old woman, a home of her own. Her "baby" has a large and fine house with spacious grounds, and in one corner in a neat little house, lives "mother," with her own "things" around her and a faithful attendant to care for her. The old lady has the satisfaction of "messing around" in her kitchen, and she can say as she "has a mind to," and it is her conviction that all old ladies should

have this privilege. The old lady's "baby" is a very handsome, big fellow, prominent in public affairs, and a man noted for the integrity of his character. He is a man of wealth and wide influence, and has the satisfaction of knowing that he has never done any-



Miss Nellie Elliott, Gen. Sec., Y.W.C.A., Winnipeg

thing to grieve his mother, who declares that he is and has always been a "good boy."

Every night of his life he goes over to the little house to say good-night to mother. He has not missed this duty and privilege a single night in more than thirty years, excepting when he has been out of the city. If he is going out in the evening, he always goes over to the little house to say "good-night to mother" before he starts, and his

kindness and tenderness to her are beautiful to witness. When he is praised for it he says, "It is only mother's goodness cropping out in me."

It is, after all, "mother's goodness cropping out" in children that makes so many good men and women in the world.

Mrs. Newell Sanders says: "Every good wife must be interested in what concerns her husband."

Edison's Tribute to His Mother

The great inventor pays a tribute to his mother which cannot fail to impress a needed lesson on the rather careless boys and girls of our day. In his childhood Edison was delicate, so that his mother, who had been a high-school teacher, taught him at home. "She had only the one pupil," says Mr. Edison, "which was fortunate for me, as I received thoroughly sound teaching. My mother also taught me how to read good books quickly and correctly, and this opened up a great world in literature. I have always been very thankful for this early training." No one appreciates better than the great inventor the part which his mother's careful training had on his career as a man. The reward, as is the case with every true mother, was in the success of her son; but a reward quite as acceptable as this is the appreciation of the child. No twentieth-century social philosophy can take the place of motherhood in its influence upon the rising generation, and any program which would destroy or weaken the purity of this relation must be condemned. The wizard Edison is but one of many thousands who owe a debt to motherhood that may never be fully paid.

The infant death rate of Huddersfield, England, was 138 per thousand before the Mayor began to offer rewards for the care of infants, and 85 per thousand after his enterprise had put

through a compulsory system of notification of births and care of children.

Nursing Contagious Diseases

By Dr. Edith B. Lowry, in Mother's Magazine

Disinfection during illness

All secretions, as that expelled when the patient coughs, should be burned. It is better to have the patient expectorate in small pieces of cloth which may be burned, than to use a sputum cup. The urine, the feces and even the water in which the patient is bathed should be disinfected before disposal so as to prevent the germs of the disease being scattered about. Chloride of lime or a five per cent carbolic acid solution may be used for this purpose. No articles should be carried from the sick room to other parts of the house. The patient should have separate dishes and these may be washed in the room. They never should be washed with the family dishes. The bed linen and night clothes should be allowed to soak several hours in a five per cent carbolic acid solution before being sent to the laundry. Then they should be boiled thoroughly and dried out of doors.

Exposing children to disease

There is a common superstition that all children must have all the so-called children's diseases and that the sooner they are over with the better, for then all worry is past. Some mothers have been known deliberately to expose their children to the contagion of measles or whooping cough. Such a proceeding should be condemned in no uncertain language. It is no more necessary for all children to have these diseases than it is for all adults to have small pox or typhoid fever. Indeed, the after effects of the latter diseases may not be nearly as serious as those from a seemingly mild attack of measles.

Measles

This apparently mild disease so often is regarded in the light of a joke that

it does not receive proper attention. In many of the smaller towns, no quarantine is enforced and children are allowed to return to school before they have fairly recovered from the disease. As a result, the other children in the room are exposed to the contagion. This should not be allowed, for the after effects of measles frequently are very serious.

Measles is an extremely contagious disease. The contagion may be present in any of the excretions from the patient. It may be carried in the clothes of a third person. One attack usually protects from subsequent attacks although recurrences have been known in the same person. However, the second attack usually is very mild.

The disease appears from seven to fourteen days after exposure. It is ushered in by a feverish cold; the eyes are watery, reddened and very sensitive to light. The nose "runs," there is loss of appetite and general feeling of chilliness and disinclination to exertion. The fever gradually rises to about one hundred and two degrees F. and may go one or two degrees higher while the eruption is appearing.

The eruption (breaking out) makes its appearance on the fourth day, usually occurring first on the forehead, then spreading to the remainder of the face and other parts of the body. At first this resembles small red papules or pimples. Later the face becomes blotchy-looking and swollen. The papules appear to be raised slightly. At times there are hemorrhages into the skin producing what is known as "black measles." Desquamation or peeling usually commences at the end of the first week. It appears fine and branlike. About the time the eruption appears on the face small, bluish-white spots surrounded by a red area appear on the mucous membrane of the cheeks and lips. These are called "Koplik's sign" and are regarded as positive evidence of measles.

The complications of measles are more serious than the disease. Broncho pneumonia not unfrequently occurs. Otitis media or inflammation of the middle ear is not uncommon. Following measles tuberculosis may make its appearance.

The child with measles should be kept in bed for about a week and quarantined for four weeks. Milk, broth, gruel and eggs should be the chief articles of diet. The body should be rubbed with oil or fresh lard every day to allay the itching and also to prevent the scattering of the desquamated skin. While the eyes are sensitive to light, the child should be kept in a darkened room or should wear dark glasses. The eyes should be cleaned frequently with a solution of boric acid. If the rash is delayed, hot drinks and hot baths may be given. A dry cough may be relieved by keeping a steaming teakettle in the room.

Scarlet Fever

This is an acute, contagious disease characterized by high fever, a scarlet rash, sore throat and a tendency to nephritis. The contagion usually is carried through clothes or in food, especially milk. The disease makes its appearance from a few hours to a week after exposure. It usually commences suddenly with vomiting or convulsions, sometimes with a chill. The throat is painful and there is difficulty in swallowing. Examination shows the throat and entire posterior part of the mouth inflamed. The tongue at first is coated, then this disappears and the papilla become bright red and swollen giving the appearance known as "strawberry tongue."

The rash usually lasts from five to seven days and is followed by a period of desquamation lasting from two to six weeks. The most dreaded complication is nephritis or inflammation of the kidneys. The urine should be examined daily, for even a mild attack of this disease may cause a serious kidney lesion. Plenty of water should be given to flush out the kidneys.

Among other complications are inflammation of the middle ear, which may produce deafness, and endocarditis or inflammation of the lining of the heart. The patient should be kept in bed even though the attack be mild, as this prevents a strain on the heart. The bowels should be kept free and the body bathed every day to relieve the kidneys of

some of their work. The throat should be sprayed or gargled every few hours with some mild antiseptic solution, as boric acid solution. The child should not be allowed to "blow" his nose hard as this tends to force some of the secretions into the passages to the ears. In this disease, as well as in measles, oil rubs night and morning are very beneficial.

PATTERN DEPARTMENT

Any of these patterns supplied by the Pattern Department of the E. H. Heath Co., for 10c., or stamps. Please order by number and state the month in which pattern appears.



A Variety of Garments that can easily be made by the Home Dressmaker.



- 7700 Fancy Blouse, 34 to 40 bust. With Long or Elbow Sleeves, with or without Frills and Chenille.
- 7677 Fancy Waist, 34 to 40 bust. With Fitted Lining, Long or Elbow Sleeves, Round or Square Neck.
- 7635 Fancy Blouse, 34 to 40 bust. With or without Chemisette, Tie Ends and Cuffs, with Robespierre Collar that can be made High or Low.
- 7477 Four-Piece Envelope Skirt, 22 to 30 waist. With or without Plaited Portions, with High or Natural Waist Line.

MAGIC

BAKING POWDER

MADE IN CANADA
CONTAINS NO ALUM
CONFORMS TO THE
HIGH STANDARD OF
GILLETT'S GOODS.

Rich in all the elements that go to make good flour. A 7lb. trial sack will make you a constant user of

PURITY FLOUR

More Bread and Better Bread

February's Greatest Brass Bed Bargain \$9.75

Thousands of Brass Beds like this one have been sold at \$18 to \$25 each, and proven satisfactory at that price. This bed is staple product of a large and reliable maker, and guaranteed perfect in material, workmanship and finish. Diameter of corner post, 2 inches; top rails, 1 in.; filling rods, 1/2 inch. Finish, satin or brass. Sizes, 4 ft. and 4 ft. 6 inches.

NEVER AGAIN

will \$9.75 bring you such a handsome Brass Bed.

POSITIVELY NO Order accepted after March 10th at above price. Order from this ad. or send for our

FEBRUARY FURNITURE BARGAIN BULLETIN

Save One-third to One-half on Reliable Guaranteed Satisfactory Furniture.

A MASTER DESIGN

2 inch Solid Brass Continuous Pillars

Handsome and Durable. An Astonishing Bargain.

High Grade, Continuous Post Brass Bed, cannot be excelled in design, material, construction or finish. The head end stands 60 inches high, the foot end 40 inches high. The massive posts and top rails are 2 inches in diameter, cross filling rods 2-8 inch thick, vertical filling rods 1/2 inch in diameter. Note especially the beautiful rounded corners, the large hucks in centre of posts. Made in 4 foot and 4 foot 6 inch widths. Best quality ball bearing casters.

Generally sold by others at \$28 to \$30. Price, \$17.50

Wingold Stores, Bannatyne Ave. Winnipeg

181-4-5

You saw this advertisement in this magazine. Don't forget to say so when writing.

I SLAVE



Narrow Minded and Set
DRUDGERY

WHICH DO YOU PREFER?

**MADAM
DO YOU REALIZE?**

What Science Has Done For You
DO YOU REALIZE SCIENCE WORKS WHILE
YOU SLEEP? IT HAS BANISHED WASH
DAY DRUDGERY FOR YOU.

It Has Produced The MARVELOUS

**I. X. L.
VACUUM WASHER**
PRICE \$3.50

I DON'T



Broad Minded, Progressive
EASE

That Washes ANYTHING and EVERYTHING From a Horse
Blanket and Overalls to the Finest Laces Absolutely
Perfect Without Injury

COUPON
BELOW
SAVES
YOU **\$2.00**

Washes a full tub of clothes in 3 minutes. NO rubbing
whatever required, consequently NO FRICTION or
wear and tear--YOUR CLOTHES WILL WEAR
3 TIMES AS LONG

COUPON
BELOW
SAVES
YOU **\$2.00**

You can wash a FULL tub of clothes as quickly and PERFECTLY as you can a single
garment. You can also do all your dry cleaning with it--A
SAVING OF MANY DOLLARS to you.

All Accomplished With NO SEVERE EXERTION WHATEVER--JOIN THE ARMY OF DELIGHTED HOUSEWIVES TODAY,
You Take No Risk.

Delivered to You All Charges Pre-Paid Under a
Money-Back Guarantee
Thousands Now in Use and

MILLIONS WILL BE

Canadian Thresherman and Farmer Coupon
Present or mail this Coupon and \$1.50 to Dominion
Utilities Mfg. Co., Ltd., 482½ Main Street, Winnipeg, Man.,
and you will receive one I.X.L. VACUUM WASHER.
All charges prepaid anywhere in Canada on condition
that your money is to be refunded if the Washer does not
do all that is claimed.
Name
Address
Province 1-2-13.

About Women

With Six Gored Skirt, Round or High
Neck, with Elbow or Three-Quarter
Sleeves.

7703 Semi-Princess Gown, 34 to 44
bust.

With Three-Piece Skirt, Long or Three-
Quarter Sleeves, with or without Chemi-
sette.

The above patterns will be mailed to
any address by the Fashion Department
of this paper, on receipt of ten cents for
each.

7692 Child's Caps, 6 months or 1 year
and 2 years.

7681 Child's Tucked Dress, 1, 2 and 4
years.

With or without Shirrings at Long
Waist Line.

707 Embroidery Design.

7695 Girl's Dress, 10 to 14 years.

With Tree-Piece Skirt, with Round or
Square Collar, Long or Low Shield, with
or without Lacings.

7686 Boy's Knickerbocker Suit, 2 to 6
years.

With Round or Sailor Collar.

7697 Child's Empire Dress, 1, 2 and 4
years.

With High or Square Neck, Long or
Short Sleeves, with Straight Lower Edge,
Adapted to Bordered Material.

The above patterns will be mailed to

any address by the Fashion Department
of this paper, on receipt of ten cents for
each.

Miss Sallie Webb, the teacher-banker
in the Cincinnati public schools, has
charge of a school savings bank—a system
organized in the schools to encour-
age children to save their pennies, nickels
and dimes.

Miss Edna Crik is the only woman
superintendent of a window glass fac-
tory. She began her career as a waitress,
but worked her way up by sheer ability.

Mrs. Eva MacDonald Valesh, is the
head of a newly organized Woman's
National Fire Prevention and Protective
Association, an organization to educate
house wives in the preventive measures
against, and primary elimination of fire.

Miss Irene Meredith of Atlanta and
Miss Kendrick of Richmond, are artistic
sign painters. Miss Meredith, who was
born in Memphis, can paint a sign any-
where and in any kind of print and

makes never less than \$75 and often \$150
a week. Miss Kendrick does scene paint-
ing for the stage and she has done much
decorative work.

Mme. de Ronsard, a heroine who
nursed British soldiers with Florence
Nightingale in the Crimean War, is now,
at the age of 84, living in an obscure
quarter of Cairo, Egypt, in sickness and
want, it is said. She commenced her
career as a sister of charity in 1849, and
was decorated twenty-two years later by
President Thiers for services rendered the
wounded during the commune.

Miss Isa Morgan, a Maryland girl,
conducts what is probably the most
unique enterprise in the States—a frog
farm—and is making money out of it.
She was a stenographer, but failing
health compelled her to take up outdoor
life. The full grown frogs bring from a
dollar to four dollars a dozen when sold
for food. Extra large specimens she
sells to biological laboratories, receiving
as much as three dollars each for them.

Part of "a Woman's Business" in Ireland

Lady Isabel Maria, countess of Aber-
deen, who is in this country for a brief
visit, in company with Miss Violet As-

quith, daughter of the prime minister of
England, is president of the woman's na-
tional health association of Ireland. She
reports progress in the eradication of the
white plague, attributing the better con-
dition of things largely to the more gen-
eral education in regard to such matters.
The woman's health association, she says
"is dedicated to just this sort of educa-
tion, and the fact that it is the 'women's
association' does not mean that the men
are excluded, but we feel that it is es-
sentially a woman's work. After all, it
means simply good food and clean things
and an open window, doesn't it? It is a
matter of the conduct of the home, and
that is a woman's business." Lady Aber-
deen has a genuinely international inter-
est in the white plague crusade, but her
special interest is in Ireland, where the
Earl of Aberdeen is Lord Lieutenant. She
has published three volumes on
"Ireland's Crusade Against Tuber-
culosis." She has been making a study
of hospitals and charity organization
methods in and about New York city.

Miss Virginia Brooks cleaned up West
Hammond, Illinois—both politically and
socially. It was full of grafting poli-
ticians. She proved that politicians are
often allowed to continue in power be-
cause reform movements are not man-

aged by leaders with half enough energy, originality and sympathy that they need to win success. The Woman's Home Companion says of her:

"Unlike many reformers, Miss Brooks knew how to appeal. In this instance 'the people' were mostly Poles. Miss Brooks began by learning their language. She then addressed them at public meetings with such effect that she completely won her impulsive, wa-o-hearted auditors. Not only was an incorporation project signally defeated, but Miss Brooks had so sturdy an army of Polish voters behind her that she felt strong enough to urge more active reforms. She started a weekly newspaper which exposed the dishonest officials who were protecting dive-keepers, and laid bare all sorts of graft in town contracts. At mass meetings in women's clubs she read out the names of all property-owners who had leased their places for questionable purposes, arousing public opinion, and sometimes hitting rather close to respectable citizens among those present. Through his agency there was posted on the front of every dive in town posters in big red type, advertising the names of the dive-keepers, with the notice:

"Warning to dives! Thirty days to vacate. Virginia Brooks.
"Fighting an organized ring is not an easy task, and Miss Brooks had many discouragements; but in the end the decent citizens were thoroughly awakened. A reform ticket was put in the field and won an overwhelming victory, and the last dive in West Hammond, called in derision 'The Virginia Brooks,' closed its doors."

At the Clinical Congress of Surgeons recently held in New York city which called forth an attendance of ten thousand surgeons who had come from all over the world to witness operations which demonstrated the great strides in surgery made in the past few years, a woman was accorded the distinction to operate before this critical body of surgeons. This woman was Dr. Mary D. Rushmore. She performed the operation with wonderful skill for she has won an enviable reputation in the profession of surgery. When asked about herself she replied: "After all, woman's real sphere is her home, and the greatest happiness comes from a congenial married life and the joy of mothering children. To achieve even reasonable success in any profession means that a woman must give up much to which she is naturally entitled and for which if she is a real woman she naturally longs. In my work, for years there was hard, uninterrupted labor. Even today I can not neglect for a moment keeping up with the strides made by my confreres, by constant study of the surgical journals and reports. While I am relieved by assistants in whom I have confidence, there is always responsibility and anxiety entailed by every operation. After each one I think over every step, wondering if I could have improved, watching developments and applying each experience to the next case. It is a profession where you can not stand still, a profession of never-ceasing work."

School Director Harry Boyle, of Oakland, Cal., has just formulated a scheme whereby he hopes to save Alameda County nearly \$100,000. He plans to have the teachers in the public schools serve as election officers. Boyle will take this matter up with a number of improvement clubs.

Young English Woman Farmers

Five young English women who run a farm and do all the farm labor themselves because they like it have been discovered by the New York Sun. Their farm—called Brockwell farm—is in Buckinghamshire. The young women are the Scott sisters, whose father, a retired sea captain, died a few years ago and left them this estate of 200 acres nestling close to the Chiltern hills. The girls—there were no boys in the family—had been born and brought up there and naturally were very much attached to the place. So they decided not to sell the farm, but to keep on living there and operate it themselves. Also they decided that it should be an entirely Adamless Eden. Not that they are man-hating bachelor girls or old maids. Nothing of that sort. They simply decided that it would simplify matters and likewise be a novelty to bar men altogether, so they hire nothing but woman

help. The girls are named Muriel, Cecily, Maude, Annie and Theresa. They wear short skirts and broad-brimmed hats when working in the fields, but when seen in town or in their reception room they are all daintily feminine. Naturally they are strong and sturdy and they really do work very hard and insist they enjoy it.

Each has a department to look after, and so well have they systematized the work that the farm is one of the most profitable in the shire and in a much more prosperous condition than when it was run by their father, with hired men to work it. At planting and harvesting time they all turn to and lend a hand to the hired women, but at other times Miss Muriel, who is the oldest, is book-keeper and financial manager; Miss Cecily has charge of the grain and the storing of farm products for sale. Three ricks that she constructed were pronounced by experts to be the finest in the shire. Miss Maude takes care of the dairy, Miss Annie looks after the trees, fruits and vegetables and also their planting and gathering. The horses also fall under her supervision, and she is an expert horseshoer, a knack which she has frequent cause to avail herself of. For that matter, all the girls are expert horsewomen, and among other things, conduct a thoroughly-equipped blacksmith shop. Miss Theresa, the youngest, looks after the chickens. The farm is equipped with every modern device in the way of labor-saving machinery, so that the lady farmers declare that farming is only a joke and not half as hard work as house-keeping.

Each one of the sisters is a musician of no small merit, and one of them is a writer and a regular contributor to magazines and newspapers, while another is an artist. On the walls of the rooms are some excellent paintings that came from her brush. They raise all the food for the live stock and produce everything for themselves except dresses, machinery and luxuries. Twice a year they hold a market of their own on the farm, and to it the farmers flock for miles around, assured that whatever they get there in the way of seeds, cattle and produce will be the best. During the rest of the year the girls send their overflow to the regular market, where it always commands the highest price.

A Heart Party By Elizabeth Burns

The invitations to this St. Valentine's party for men and girls read as follows: If your heart is empty,
Void of joy and treasure,
Come to my home on Friday night
And fill that void with pleasure.

Most heartily yours,

Mary Smith.

Partners for the first game of the evening were chosen by the mending of broken hearts. The men were given cardboard hearts broken in various ways, the girl whose portion of heart "needed" the man's broken heart was to be his partner for the game of Hearts.

For this game, cubes, or "dice," were made from wood. On each side of the cube was printed or burned one letter of the word H-E-A-R-T-S. Two couples played at each table. The dice were shaken, thrown on the table, and tally kept. At the end of a stated time the couples whose tallies were largest progressed. As the dice were thrown on the table, various words were spelled.

"H" counted 5.
"He" counted 10.
"Heart" counted 20.
"Hearts" counted 25.

The second game was the fashioning of one's heart's ideal from gum. To each guest was given a cardboard heart about four inches in diameter. In addition to cardboard hearts the hostess provided two sticks of gum for each participant in the game.

When the gum had been chewed and softened, it was transferred to the cardboard and molded into all sorts of "ideal" profiles, "full-face views," and "full-length portraits." The ideal of one modest maiden proved to be an Indian with a ferocious array of feathers, and there were others equally amusing.

Various prizes are given: a heart-shaped box of bonbons; a consolation prize of a tiny cany heart inscribed with the comforting words "Cheer up," and a heart-shaped emery pierced with needle darts.

RARE QUALITY FURS AT RECORD PRICES

Make your visit to the **BONSPIEL** a means of profit as well as a good time at the "Roaring Game." You can do it in a brief visit to the **Fairweather Fur Store**, where a great mid-season Clearing Sale is in progress, with special price-increments

During Continuance of Bonspiel

Big Discounts are marked on all our Furs and Fur Garments, perfect goods and first quality pelts in every case, solely for the purpose of making a complete clearance that we may start the new season with nothing in our fixtures but New Season's Goods.

Ladies' Fine Broadcloth Coats

lined throughout with chamois and satin, or good quality Muskrat and trimmed with dark Eastern Mink. Reg. \$125.

For \$83.50

Ladies' French Dyed Hudson Seal

deep shawl collar and cuffs, 50 and 52 inches long. Reg. \$200 and \$225.

For \$155

Ladies' Muskrat Coats

50 and 52 inches long, high storm collar and cuffs. Reg. \$100.

For \$67.50

Ladies' Russian Pony and Marmot Coats

50 inches long, shawl collar and cuffs. Reg. \$75.

For \$60

Men's Raccoon Coats

50 to 54 inches long. Shawl and notch collars. Reg. \$75.

For \$56.25

Men's Muskrat Lined Coats

with Otter and Persian Lamb collars, and in English Beaver shells. Reg. \$100.

For \$73.50

Men's Fine Hair Beaver Coats

natural Otter shawl collar. Reg. \$275

For \$200

Men's Black Dog and Corsican Lamb Coats

Reg. \$20 and \$35.

For \$15 and \$25

This is an Exceptional Opportunity

Fairweather
& CO. LIMITED

If you are not attending the "Bonspiel," write for Illustrated Catalogue with our Revised List of Clearing Prices.

297-9 Portage Ave.
WINNIPEG

ALL FIRST PRIZE GOODS BLUE RIBBON TEA



Blue Ribbon Coffee and Blue Ribbon Baking Powder have the same good Quality that Blue Ribbon Tea is famous for. They are guaranteed superior to all others and if you buy any one of those articles you are at liberty to return it and have your money refunded, but we know you will prefer to keep the goods.

Home Economics

As this department must go to press early this month, the home economics reports and also the report of the convention will be published in the March number. The special number for grandmothers will also be in March. We hope to receive many letters from our readers telling us about some memories of their grandmothers. Let us make this an interesting feature of the March number.

VIRDEN

A review of what one Home Economics Society has accomplished for its community.

Dear Mrs. Hamilton:

I thought it might be of interest and encouragement to your readers to give a description of what our Home Economics Society in Virden has been able to accomplish during the year. We have been just two years in existence and have grown from seventeen to over one hundred and fifty members, many of whom drive in ten miles and one fourteen to attend our meetings and these are among our most regular attendants. One of the greatest benefits of this society has been to make the town and country people better acquainted, hence better friends. We have emphasized the importance of labor saving devices in the home, and many of our members are using the vacuum cleaner, etc.

We have splendid addresses by our clergymen, doctors and others, but many of the very best from our own members on such subjects as "Music in the home," "How to succeed with plants and bulbs," "Are our ideals high enough," "Boys," etc. Much of our work, however, has been done for the community and school. Our very first work was the improvement of our cemetery, which like most others in the West, was sadly neglected and, as our town is one of the oldest, had lain so for thirty years. We met our town council, which was an unheard of thing for women, and with their aid and the advice of our Deputy Minister of Agriculture have changed the place from a wild uncared for estate to one of beauty, for so short a time and order. We have a wide wind break all around it ready for planting next spring, every grave levelled and every lot in order, borders and flower plots planted with trees, shrubs and perennials. Our town council gave us a one-horse mower and had all stakes levelled so we could use it. We collected from plot owners about three hundred dollars which enabled us to keep a caretaker all summer, and the ladies turned out and repeatedly poisoned gophers which were so dreadful, until during the latter part of the summer there was scarcely one to be seen.

We have obtained medical inspection for our consolidated schools and through the influence of our country members it is being extended to the rural districts and I may say that the first semi-annual report amply justifies the necessity.

We took up tag day for Ninette Sanatorium and made \$236.

We were asked by our town council to endorse the curfew, which we were glad to do, and our children are now off the street at 9 o'clock.

We were the first society that planned to have an exhibit at Lethbridge, and through our local member, Mr. H. C. Simpson, had it brought to the notice of the Minister of Agriculture, and then uniting with six others and with the aid of the department of transportation, etc., won first prize, a solid silver tea service given by the Regina Board of Trade, for our province. Virden winning 1st on pickles, preserves, etc., as well as on eggs and fancy work. In conjunction with the W.C.T.U. of our town we have maintained in it reading and rest rooms during the past year where our women driving in may be warmed, have a cup of tea, wait for husbands and have every convenience for tiding up. Our reading room is well supplied with the daily papers, magazine and books, given by the people of the town. We asked every family for a book. One of our doctors gave a set of history and biography, many others gave more than one, so we have a nice collection. Men and boys or any one may

spend here an hour or two, at any time thus helping to keep some at least from public bars, pool rooms, etc., and we hope help them to form the reading habit. Our magazines are all passed on to those wishing them. Our fee is only 25c. This debars no one, and we never ask for more in the society as our object is not money making. We have our cemetery improvement association formed from our members and men whom we have asked to join it. The reading and rest room committee, composed of our members and those from the W.C.T.U. carry on the work with an advisory board of men. We meet every month, June, July and August at the homes of our country members. Not the least important part of our work is the welcoming of strangers, a warm handshake to all who come. We have always served a cup of tea, and we always have good music, usually vocal, by our young people.

I would like to see every woman in the Dominion belong to one of these societies. I am sure we would then have higher ideals for both home and country. I would also like to see the different provinces of the Dominion united under one name, as was suggested by Mr. Patman at the Lethbridge Congress.

(The above review shows a marvelous development and accomplishment for a community.)

If every town in Manitoba had a society like the one at Virden, there would be no need of a "Million for Manitoba League." P.R.H.)

Deloraine

Home Economics Society

The annual meeting of this society was held in the basement of the Presbyterian Church on Saturday, Dec. 7th, and was well attended.

The annual report of the secretary, Mrs. W. I. Thumas, showed a membership of 44, that the society had held ten meetings during the year, with an average attendance of 28. There was also a special meeting addressed by Mrs. Stavert, of Winnipeg.

The election of directors resulted as follows: Mrs. Robert Gowanlock, Mrs. Weidenheimer, Mrs. Wm. Terryberry, Miss Jean Scott, Mrs. J. M. Rankin, Mrs. R. Price, Mrs. Jas Steedsman, Mrs. Wm. Steedsman, Mrs. W. J. Thomas, Mrs. R. S. Thornton.

The directors afterwards met and appointed Mrs. Thorton, President; Mrs. Gowanlock, Vice-president, and Mrs. R. N. Dymond, Secretary.

RECEIPTS

Substitute for Meat

Cook one pound of macaroni in boiling water until tender. Then place in a buttered baking dish, first a layer of macaroni, then cheese, seasoning with salt, pepper and butter. Take two eggs well beaten, add a cupful of sweet milk, then pour over top of macaroni. Bake for about one-half hour or until a nice brown.

Suet Pudding

One cup of suet, chopped fine; one and one-half cups of brown sugar; one cup of sour milk; one cup each of currants and seeded raisins; two and one-half cups of flour; one teaspoonful of soda; one teaspoonful each of cloves, allspice and cinnamon; one-half teaspoonful of salt and nutmeg. Mix all together thoroughly, and steam for three hours. It may be put into several smaller molds if one desires, in which case it need not be boiled quite so long. Serve with hard sauce.

Gingerbread

One cup of sugar, two cups of molasses, one cup of sour milk, two-thirds of a cupful of lard, one cup of raisins, a heaping teaspoonful of salt and one of soda, half a nutmeg, half a teaspoonful of cassia, a tablespoonful of ginger, and just a pinch of cloves.

Raised Cake

Three large cups of bread dough, two cups of sugar, one-half cup of milk, four eggs, one-half cup of melted butter, one-half teaspoonful of soda, the same of cassia, half a nutmeg, one cup of seeded raisins, and flour enough to make it of the consistency of pound cake. Beat well and let it rise in bread tins as you would yeast bread and bake in moderate oven.



TO OUR FRIENDS WHO INTEND TO VISIT WINNIPEG DURING BONSPIEL WEEK

We extend a most cordial invitation to visit our store.

You will find our salesmen most willing to show you round the store and glad to give you any information they can regarding Diamonds, Fine Jewellery or Silverware.

D. R. DINGWALL

LIMITED

JEWELLERS and SILVERSMITHS Cor. Portage Ave. and Main Street

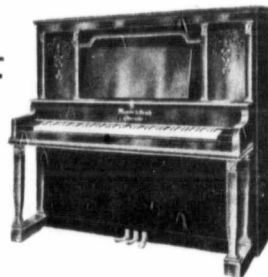

Mason & Risch Pianos

From "Factory to Home"

17 Western Branch Stores

For nearly half a century, the name MASON & RISCH has been a guarantee of the highest attainments in piano building. To your fathers and grandfathers it stood for sterling integrity, for all that is good in piano making. Truly, everything that intimate knowledge of the piano industry could put into an instrument is summed up in the name MASON & RISCH.

We built our first piano half a century ago. Since then, the MASON & RISCH PIANO has carried the fame of this house to the farthest musical centres. And if you are ever likely to buy a high-grade piano, remember "YOU PAY FOR THE PIANO ONLY." Not a dollar is added for the name and fame.

Our "FACTORY-TO-HOME" plan of selling, which means that you can buy MASON & RISCH PIANOS direct from the maker through our SEVENTEEN WESTERN BRANCH STORES, has been the means year after year of saving thousands of dollars to piano buyers. Write us for catalogue and full information before placing your order for a piano.

Mason & Risch Limited

Factory Branch:

272 Portage Ave., Winnipeg

The Greatest Thing in the World.
 The Story of a "Lunger"

PREACH health to the City man who thinks himself only half-sick? To the wreck buoyed up daily by an elusive tide of wealth?" Dr. Briggs turned with a sceptical shake of the head towards three blanket-enveloped men reclining in invalid chairs. "Might better try to hold Niagara from tumbling over the falls! No, sir, you fellows welter along until the acid atmosphere bites a piece out of your lungs—then you take the Lungers' Express for the health resorts. And, believe me, the symptoms of every one of you are identical: weak lungs, dim vision, mean thoughts, soul shrunk like a pigmy's, and a dark-brown taste of defeat on waking even on the brightest of mornings—haven't I hit it?" He paused inquiringly.

Baldwin and Meeker had arrived from the East in a very fragile condition of health the day before. Belclair had been a patient at the doctor's tiny log-cabin sanatorium—perched on a rocky mountain-side several thousand feet above the lovely Paradise Valley—for the past week. On the broad verandah, where they now sat enjoying the crisp evening air of the mountains they likewise ate, slept—and lived. The doctor's discourse with his patients always had in it all the vigour of tone, suggestion, and effect of a tonic itself. They always seemed content to nod languidly, and he was well pleased to carry on the lion's share of the conversation.

"Yes, you come out here half-dead," he continued, "filled with a dread of bitter doses to come. And what do I prescribe? Why, simply a steady diet of this clear-aired, rugged region! For breakfast I have you take a full-fledged mountain range; for lunch a noon-day vista showing the world under your feet; and, before making a supper off of fresh, giant-hill thought, I arrange for you to bathe for one hour in ruddy mountain sunset cooled by the rising mists of a hundred-mile valley! And what is the result?" he concluded, carrying his hearers along with his own exuberance. "Why, in a couple of years you have a vision that can see back to the heart of Adam—thoughts big enough to hold the universe, and still leave room for heaven; a soul capable of all the primæval joys of man seasoned with essence of heaven; and a daily waking sense of the power to tear up forests by

the roots and lead a host to conquest."

The three invalids had turned in their chairs, surveying him with a look that plainly said that they considered him but another—and most remarkable—wonder of this great and glowing West. Baldwin had stretched his thin neck far out of his blanket like a turtle, while something like hope came in his eyes; Meeker's dead-white hands flashed in the dim light as he seized the arms of his chair in an effort to brace up; Belclair chewed his thin moustache more determinedly.

"I know, gentlemen, that sounds as though I was laying it on thick," observed the doctor, meeting their gaze, "but some of the miraculous changes in human natures that I've seen are almost beyond comprehension.

"I can't explain what it is that gets into the people up here," he went on, his tone touched with a mysterious softness, "some uncatalogued elixir in the air, maybe. But you get these high places into the system; you begin to see and reckon everything from a great altitude, and get to be on speaking terms with the heavens and the stars, and see men and their mightiest works like ants crawling about their hills far beneath you.

"Then there comes a final stage in your development—I've felt it; they've all felt it—some day it'll sweep you fellows off your feet like a whirlwind inspiration," he assured them, fixing his clear gaze on each. "And then every mother's son of 'em—and daughter, too—gets the inevitable idea—namely, of doing the greatest thing in the world.

"Look up there above us—see those lights?" The doctor lifted his powerful arm, pointing towards twinkling points flashing here and there like jewels among the crags above. "Lungers' shacks, every one of 'em. Came here to die. Now they're staying here to live out long lives! That's where my patients go when they begin to get well, and the magic spell I speak of seizes them."

"And you may readily guess their little dramas are interesting," the doctor observed, filling his pipe. "Some are ludicrous, while others are pathetic and a few sublime, for it never fails to bring to the surface the primitive character of man, although buried for a thousand years among his ancestors.

"I'll give you briefly the history

Royal Household Flour
 Strength Nutrition Purity
The highest standard of perfection
 At All Grocers

You saw this advertisement in this magazine. Don't forget to say so when writing.

Lend Variety to the Daily Menu
 And add to the enjoyment of home cooking by using

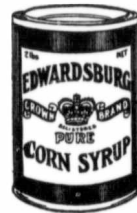

Crown Brand
Corn Syrup

The purest and most delicious table syrup obtainable.

Crown Brand—clear as strained honey—gives a delightful flavor to dumplings, puddings, pastry, etc., and is especially desirable for serving with Buckwheat and Griddle Cakes, Cookies and Biscuits.

It is a most nourishing food—splendid for children, because it is so easily digested.

Next Time Try Crown Brand—Your Grocer Has It

The Canada Starch Co. Limited

Manufacturers of **EDWARDSBURG** BRANDS
 Montreal Cardinal Toronto Brantford Vancouver

You saw this advertisement in this magazine. Don't forget to say so when writing.

Don't Fail to Renew Your Subscription
Before it is Too Late.

Pitner Portable Lamp

HERE is an illustration of the **Pitner Portable Lamp** with amber art shade No. 1473 (with plain 12-inch opalescent shade No. 961), which is considered by connoisseurs to be the only good lamp.

It can be burned at any desired brilliancy from five to one hundred and twenty-five candle power, and will give the whitest and purest light known to mankind. Manufactured of the best material, is artistic, and in every way better for household purposes than the kerosene lamp. Safe to handle, is perfectly clean, no odor, no wicks to trim, no glassware to keep clean, nothing to go out of order. A book of instructions accompanies each lamp, which is numbered, and corresponds with the number at the base of the

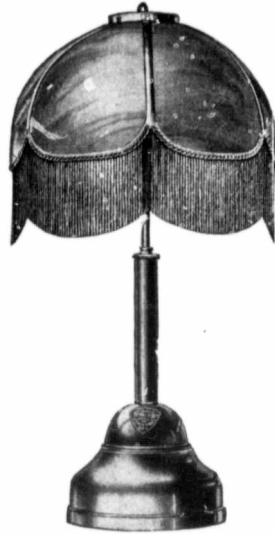

lamp. Guaranteed for a period of five years to give the owner perfect satisfaction in every respect, and if it fails to do this we agree to furnish a new lamp, or put same into thorough working order, gratis, any time within said period. It can be used in or out of doors, tied to a limb of a tree; used in and around the barn with perfect safety.

We carry in stock many designs in art glassware. Shades and globes can be attached rigidly to the holder, or otherwise. Please state requirements in ordering. Purchase one of these lamps for your home and you will find it will be one of the best investments you have made in your life.

Hardware Merchants, write us for full particulars

Portable Lamp Department

LIGHTING SYSTEMS LIMITED

62 Albert Street, Winnipeg

You saw this advertisement in this magazine. Don't forget to say so when writing.

of a case in point if you'd like—the most remarkable one, by the way, I've known. It can't fail to interest and encourage you. Besides, you'll never meet the Corsons, for a couple of months ago they moved away to a mountain region somewhere in Montana—for sufficient reasons, you'll agree."

The doctor paused a moment as though waiting for a voice of dissent. Noting, however, only a movement of expectancy on the part of his silent hearers, he proceeded without interruption:

Corson had been caught young, there in your city, between the upper millstone of money and the nether one of desire to get more, and ten years of grinding had worn him—body and soul—as thin as a transparent wafer. When I got him all the opaque and solid features of a man—health, ambition, will power—were gone! The most noticeable signs of life were a few drops of anemic blood, which now and then stained his handkerchief.

An immediate examination showed that his lungs weren't so bad; but rather that for years he'd been feeding ambition with his vitals—like the Spartan youth and wolf you read about. And, too, he'd given up hope, which I warn you, is a terrible thing.

I gave the man a month to live

—even in this healing atmosphere.

Up to that time I had not taken into consideration one element—or person, I should say—Corson's young wife.

It was she who had brought him, bodily—still fighting against it—to me.

Mrs. Corson was a little woman; with a stocky form that made you think of a stone wall. After that I can only remember—one can never forget them—her eyes! Gad, what eyes! They spoke, they sang, they pleaded, they wept, and finally—they won! I'd tell you they were black if I was sure they were, but I've seen them a troubled green and a fiery red as well. The first time I looked into them they swept my brain like a shower of burning sparks. I was numbering her husband's days when she came forward, seizing my hand with a firmness that told of purpose and capability. She had divined my thoughts.

"Doctor, you and I are going to save my husband's life," she said, in a subdued tone he could not hear. "He's given it up; so 've you—but I haven't. I've strength, health, hope—everything that he hasn't. If necessary I mean to put them all into him. I'm determined to save his life, even if it takes mine to do it. I'm a lover

and a worshipper of life, and I consider it the greatest thing in the world! Therefore, don't be afraid, doctor, to put my determination to any test."

Well, the effect of this girl's words and personality on me was galvanic. I cast a sidelong glance at the human wreck and saw him in a new light.

"Let me suggest first of all, doctor," she continued, "that he hates medicine. Give him as little as possible—rather treat his imagination. It's the only faculty that hasn't been undermined; in fact, it's his most powerful natural gift, and if we can rouse it, he's saved!"

"Then have no fear, for the daily scene from this verandah will stimulate and gratify the greediest imagination."

"Then we've solved it!" she cried, as though her husband had already risen endowed with the health and strength of the hills.

The woman's vigour and courage were wonderful.

Next day the battle royal began; Corson wasting his meagre strength to resist every effort that was made to help him, and she willing that he should be helped to live.

Day after day they sat on this verandah. He listless, his mind and soul wrapped in an almost palpable mantle of death and de-

feat—petulantly refusing to see, to eat, to live. And she—she was everywhere, she did everything, she saw everything, and when he would show a glimmer of intelligence then she described to him what she saw yonder across this grand valley of ours, in a low voice that swept along like an artist's brush, painting scenes with wonderful outline and color. Even then for days he scarcely lifted his eyes.

Although I knew that the man was sick—that the flame of life barely flickered—I hated him for what appeared such downright stubbornness under that girl's compelling suggestion.

Then suddenly—it was on a splendid evening during the third week they were here—things—our things up here—the wine-like air, the immensity of space, and all—began to grip him. All through her vital efforts, to be sure.

The three of us sat, as most people do of a night up here, marvelling that the things that we'd always thought of as impossible and far away seemed so—well, so near and possible to us. When suddenly Corson, in almost the first words he had uttered, echoed this very thought: "Look at the stars," he said, "seems as though one could pick a basketful from that ridge opposite!"

"Isn't it wonderful!" breathed his wife, meaning something more than the proximity of the stars.

Many minutes passed in silence, and I could see from the brilliance of her eyes that they were singing a song of thanksgiving. Then he spoke again after puzzling out something in the distance:

"See that sword-gash in the side of that mountain over there, Jennie? Well, there's blood rising from the wound!"

Mrs. Corson looked in alarm, first at her husband, then to the place he had indicated.

"A fire in the valley—isn't it, doctor?" she asked, turning to me.

I, too, had been watching it. In the deep cleft of the mountain's silhouette yonder a lambent blood-like flame was slowly jetting, bearing little resemblance to the rising moon, and seemingly more than three thousand feet below us.

Of our three visions, his was by far the most sublime—that was the point.

At last she had done it. His wonderful imaginative powers had been fired!

From that day she, too, took to gazing over the crags and precipices and muttering "the greatest thing in the world."

Of the two he was the more reckless and daring, she more practical and shrewd, and born to conquer, as I've repeated so often. And she resolved that she would show him the greatest thing in the world: subordinate his idea to hers! But how, was more than I could guess. I made bold to ask her.

Her reply was writ in her eyes, which took on a depth too profound for me to fathom. Her expression was that of Mona Lisa over again: the enigmatical eyes, the smiling lips, and behind it all the indefinable triumph! But it did not disclose her mode of warfare.

But not so with Corson. I was made acquainted with his doings down there in San Luis—that great pool of lights yonder to the right. His mad recklessness had won for him the name of "Dare Devil Corson."

Now nothing can win the hearts of our Western people more effectually than a man whose deeds are coloured by daring bravado. It happened that a man with such a character was greatly in demand at this time, because of the murderous incursions of a band of "greasers" desperadoes that periodically swept down from an almost inaccessible retreat in these mountains. A deed that will ever outshine all others in the annals of San Luis County was the capture of "Rattlesnake Miguel," the leader of this gang, by Corson.

Very little is known of the details. Suffice it is to say that

Corson found the outlaw's retreat, surprised Miguel alone, bested him, and took him singlehanded to San Luis!

During the few weeks that followed this remarkable performance I saw nothing of the Corsons. For one reason, I was kept busy with three very sick newcomers; for another, Corson no longer passed by my house here on his daily trips to the valley, but had made and used a new path from Cragside that required a daring man indeed to traverse.

So I only saw his Quixote-like form from a distance stalking among the perilous crags.

Well, I was not surprised when I heard that they had made him Sheriff of San Luis County. I went up at once to see his lonely wife.

"He has taken the odious office despite my pleading and entreaties—just as he does all things these days," she said, and I could see in her expressive eyes that she looked on this as a defeat in the contest. "Why, doctor, the man

exhibits the rapacious instincts of a bloodhound in his desire to pursue, to hunt to death if need be, fugitives of the law. He holds me and my ideas in utter contempt, he tries to overawe and conquer them by his bloody ones," she went on, turning to me with a fine scorn. "But wait, I tell you, we shall see what the greatest thing is; you shall be a judge of that, too, doctor."

I left her at the threshold, with again that strange triumph in her eyes which I could not fathom.

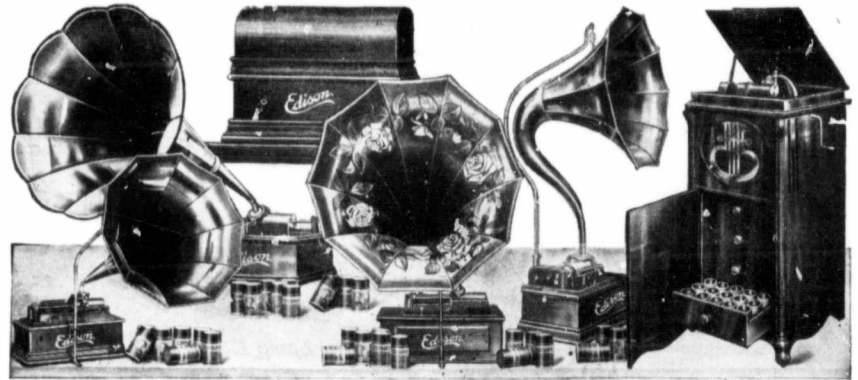

Wonderful NEW Edison Shipped

FREE



Mr. Edison's Pet and Hobby

He realizes the wonderful value of his phonograph as a reminder of home ties and as a maker of happy homes. And for this reason he worked for years striving to produce the most perfect phonograph. At last he has produced this new model, and his friends have induced him to take the first vacation he has had in over a quarter of a century. Just think of it: over twenty-five years of unremitting work on many new inventions—then his pet hobby perfected—then a vacation.

Write today for our New Edison Catalog that tells you all about the wonderful new model Edison with Mr. Edison's new model R Reproducer and the new parlor grand equipment. With this catalog we also send full explanation of our free shipment offer.

The Offer We will send you the new model Edison Phonograph and your choice of over a thousand records on an absolutely free loan. We want you to have all the waltzes, two steps, vaudeville, minstrels, grand operas, also the sacred music, etc., etc., by the world's greatest artists. Entertain your family and your friends. **Give plays and concerts right in your own parlor.** Hear the songs, solos, duets, and quartettes, the pealing organ, the brass bands, the symphony orchestras, the choirs of Europe's greatest cathedrals, the piano and violin concerts, virtuoso—all these we want you to hear **free** as reproduced on the new Edison. Then, when you are through with the outfit you may send it back to us.

Mr. Edison Says

"I want to see a phonograph in Every Home."

Read this remarkable free shipment offer on the first lot of the new style Edison Phonographs—these new Phonographs to be shipped **free** on this special offer now.

The Reason

Why should we make such an ultra-liberal offer? Why should we go to all this expense and trouble just so you can have all of these free concerts? Well, we'll tell you. We are tremendously proud of this magnificent new instrument. When you get it in your town we know everybody will say that nothing like it has ever been heard—so wonderful, so grand, so beautiful, such a king of entertainers—so we are pretty sure that at least some one, if not you, then somebody else, will want to buy one of these new style Edisons (especially as they are being offered now at the most astounding rock-bottom price and on easy terms as low as \$2.00 a month.) But even if nobody buys there is no obligation and we'll be just as glad anyway that we sent you the New Edison on our free loan; for that is our way of advertising quickly everywhere the wonderful superiority of the New Edison. But don't delay sending the coupon today.

Why should we make such an ultra-liberal offer? Why should we go to all this expense and trouble just so you can have all of these free concerts? Well, we'll tell you. We are tremendously proud of this magnificent new instrument. When you get it in your town we know everybody will say that nothing like it has ever been heard—so wonderful, so grand, so beautiful, such a king of entertainers—so we are pretty sure that at least some one, if not you, then somebody else, will want to buy one of these new style Edisons (especially as they are being offered now at the most astounding rock-bottom price and on easy terms as low as \$2.00 a month.) But even if nobody buys there is no obligation and we'll be just as glad anyway that we sent you the New Edison on our free loan; for that is our way of advertising quickly everywhere the wonderful superiority of the New Edison. But don't delay sending the coupon today.

FREE Our New Edison Catalog

Write today for our New Edison catalog and learn all about the wonderful New Edison. Learn how thousands of people are entertaining their friends by giving Edison concert—learn how the boys and girls are kept at home and all the family made happy by the wonderful Edison. No obligations whatsoever in asking for this **MAGNIFICENTLY ILLUSTRATED** catalog, so send the free coupon now—today.

Babson Bros. Edison Phonograph Dist., Dept. 7709
355 Portage Ave., Winnipeg, Man.

U.S. Office, Edison Blk., Chicago.

FREE Coupon

BABSON BROS.
Edison Phonograph Distributor
355 Portage Ave., Winnipeg, Man.

Dear Sir: Please send me your New Edison Catalog and full particulars of your free loan offer on the first lot of the new model Edison Phonograph.

Name.....
Address.....

One Half Bottle Earned Him \$50

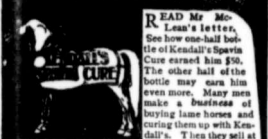

Kendall's Spavin Cure

It will be ready to cure cases of Curb, Spavin, Splint, Ringbone, Bony Growth of Lameness from bruises or other causes. Thousands of other farmers are doing so—have been doing it for over 35 years. It's the only safe remedy you can depend on. Get a bottle at once and see how much it will save or make for you. **42 drops give \$1 a bottle; 6 for \$5.** Ask your druggist for book, "Testimonials on the Cure," or write to: **D.R.E. KENDALL COMPANY** Essexburg Falls, Vermont.

Foot Wound, Nerve Sores, Gout, Rheumatism, etc. I bought a cure and got it cheap on the account of a friend. I got your cure and it cured me. I cannot say too much for it. Very truly yours, **Laury M. Lee.**

Run Your Binder with a Cushman Engine

Only two horses required—smooth, even running—no failures to bind—work goes right along.

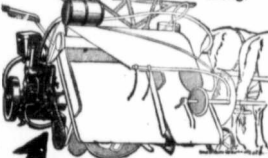

Horses Simply Draw Machine
The engine does all the work of operating. 4 h.p. Weight under 200 lbs. Speeds to 5 h. p. easily. Automatic throttle governor measures out fuel according to work. The original binder engine and more in use than all others combined. Detach and use for all-purpose farm power. Easy to handle, fits in anywhere. We also build 6 and 8 h. p. engines with same high efficiency—engines for all heavy duty. Write for free catalogue. **CUSHMAN MOTOR WORKS,** 2022 N St., Lincoln, Neb.

Farm Cushman The Original Binder Engine

Mention this magazine when writing advertisers

THE CENTRAL CANADA INSURANCE COMPANY
INCORPORATED IN CANADA
INSURANCE AGENCIES LIMITED
General Agents
Jos Cornell
Sole Agent
THE ALBERTA-CANADIAN INSURANCE COMPANY
INCORPORATED IN CANADA
THE MONTREAL TRAVELERS' ASSOCIATION
INCORPORATED IN CANADA

Best Service at lowest possible cost

Be Prepared!

The only farmer in an entirely safe position, is the farmer who takes advantage of the protection afforded by sound insurance. We write fire, live stock and hail insurance policies under very favorable policies, giving the best service at the lowest possible cost consistent with reliable protection. We have the benefit of years of experience in Western Canada, and insure the same men year after year. Enquire about our rates, policies and service, addressing any of the Companies shown above or **INSURANCE AGENCIES, LTD.** General Agents
Brandon Winnipeg Regina
Saskatoon Edmonton Calgary
Or see one of our 1,200 local agents.

Mention this magazine when writing advertisers

Again I wondered how she was going to make the slightest impression on the fervid purpose of a man such as Corson had become.

Tales of Corson's unmitigated fool-hardiness and daring became the subject of county talk. I expected any day to hear of his meeting a violent death. The subject became one of such painful anxiety to me that, knowing I could be of no help to his brave wife except in extremity, I charitably kept aloof from Cragside—hourly awaiting a summons.

Yet I suppose it must have been five months later, one afternoon, as I sat here in the twilight, that I saw someone almost tumbling over the crags up yonder, tearing in wild haste towards my shack. In the first shock of alarm the gathering fears of the past months whispered that at last the messenger had come telling me fatal news of Corson.

It was news from Cragside—brought by Corson himself, though. His wife was desperately ill!

After telling me this in a breathless gasp, he made a bound on the downward path towards the valley.

"Where the devil are you going?" I hailed, noting, as he turned, the strange fire in his eyes, which I had mistaken for solicitude.

"Why, haven't you heard?" he cried, pausing a moment. "Rattlesnake Miguel' broke out of gaol last night!"

"And your wife?" I demanded, subduing my wrath by making my query one of biting sarcasm.

"Well, the truth of the matter is the sheriff has got to get that villain—dead or alive—and I'm the sheriff!"

"Well, I hope to heaven—" I began, but he disappeared before I could finish my malediction.

"Well, that plucky little woman put in five ugly days and nights with death ever hovering at the door, chilling her heart and mine with his icy breath. Perhaps if she hadn't tried to conceal the great secret—heaven alone knew why then, I didn't—from his only half-seeing eyes, she would have fared better in her first ordeal of motherhood.

My heart mourned for her sad state of neglect, coupled to her precarious condition. For during that agonizing five days we received no word of Corson, except in the person of a trained nurse, whom he had hastily sent up from San Luis.

In the event the little woman did not succumb in one of the pluckiest struggles against death that I had ever witnessed. I fully anticipated a subsequent scandal, in which she would separate from her neglectful brute of a husband to let him go along his reckless, selfish ways alone.

For Sale By Original Inventor

(Patent No. 133694)

Improved Spark Arrester for Steam Engines, either portable or traction. Will positively prevent any live sparks from escaping and at the same time does not in any way interfere with the draft of the engine. It has been thoroughly tested. Testimonials from users gladly furnished. Will sell either Canadian or U.S. patents or shop rights.

Full enquiry solicited

W. Crawford - **Erinview, Man.**

You saw this advertisement in this magazine. Don't forget to say so when writing.

Big Ben

Big Ben—Two Good Alarms in One

Take your choice in Big Ben. He rings either way you wish—five straight minutes or every other half minute for all of ten minutes unless you switch him off. He's two alarms in one.

If you're a light sleeper, turn on the half minute taps before you go to bed. If you sleep heavily, set the five minute call. You can slumber then without the get-up worry on your mind.

When morning comes, and it's announced by Big Ben's jolly bell, you can't help getting up at once, for Big Ben never fails to get you wide awake.

Big Ben is really three good clocks in one, two excellent alarms and a fine time-keeper to keep in any room and tell time all day by.

If you have got to get up bright and early, if you have to get your help in the field on time, ask for Big Ben at your dealer's and try him for a week. You'll never want to be without him afterwards.

Big Ben stands seven inches tall. He is triple nickel-plated and wears an inner vest of steel that insures him for life. His big, bold figures and hands are easy to read in the dim morning light. His large, comfortable keys almost vind themselves.

He rings five minutes steadily or ten intermittently. If he is siled every other year, there is no telling how long he will last.

He's sold by 6,000 Canadian dealers. His price is \$1.00 anywhere. If you can't find him at your dealer's, a money order mailed to *Windsor La Salle, Illinois*, will send him anywhere you say duty charges prepaid.

You saw this advertisement in this magazine. Don't forget to say so when writing.

12-Gauge Hammerless "Pump" Guns

The Marlin

Hammerless 12-gauge repeating shotgun, Model 28, is a fine-appearing, beautifully balanced gun, without any objectionable humps or bumps; no holes on top for gas to blow out through or water to get in; can't freeze up with rain, snow, or sleet; it's solid steel breech (not a shell of wood) permits a thoroughly symmetrical gun without sacrificing strength or safety; it is the safest breech-loading shotgun ever built.

It is Hammerless with Solid Steel Breech (inside as well as out)—Solid Top—Side Ejection—Matted Barrel (which costs \$4.00 extra on other guns)—Press Button Cartridge Release (to remove loaded cartridges quickly from magazine without working through action) Double Extractors—Take-Down Feature—Trigger and Hammer Safety. Handles rapidly; guaranteed in shooting ability; price standard Grade "A" gun, \$22.50.

Send 3 stamps postage for Big Catalogue describing No. 28, A, B, C, D, T and Trap Special and all other Marlin repeating rifles and shotguns. Do it now!

The Marlin Firearms Co., 106 Willow Street, New Haven, Conn.

You saw this advertisement in this magazine. Don't forget to say so when writing.

ALBERTA INCUBATOR
125 EGGS
RAISE MORE POULTRY!
Largest profits by using our Canadian made incubator, built by poultry men of 15 years' experience. Just all stages of experimenting, proven the best by thousands of pleased users. None better at any price. Why? Only middlemen's profits when our large factory saves you half on the one high-grade 100 per cent hatch-recovery machine.

PROVEN SUCCESSFUL IN CANADIAN CLIMATE
Coming in the heavy winter with general cold, high, adverse winds, frost, snow, or crack, our incubator will keep you warm. It is light, can't burn, won't tip over, and is easy to clean. It holds even heat. Safety lamp saves oil. Low cost, low fuel, low maintenance, high economy, comes set up ready for operation. Simple, safe, sure, simple, a child can operate. Homeowner can take up stock earlier.

Also low prices on brooders, poultry and supplies. Write for catalogue and value book worth \$1.00 to you. **FREE!** Write postal note!

Alberta Incubator Co., Box 882 Mankato, Minn.

250 Egg \$17.95
Show Clutch From \$10.00
Winnipeg or Toronto

Guarantee Two Hatch Trials.
NO DUTY

Mention this magazine when writing advertisers



SYNOPSIS OF CANADIAN NORTH-WEST LAND REGULATIONS

Any person who is the sole head of a family or any male over 18 years old, may homestead a quarter-section of available Dominion land in Manitoba, Saskatchewan or Alberta. The applicant must appear in person at the Dominion Lands Agency or Sub-Agency for the district. Entry by proxy may be made at any agency, on certain conditions, by father, mother, son, daughter, brother or sister of intending homesteader.

Duties—Six months' residence upon selection of the land in each of three years. A homesteader may live within nine miles of his homestead on a farm of at least 80 acres solely owned and occupied by him or by his father, mother, son, daughter, brother or sister.

In certain districts a homesteader in good standing may pre-empt a quarter-section alongside his homestead. Price \$3.00 per acre. Duties—Must reside six months in each of six years from date of homestead entry (including the time required to earn homestead patent) and cultivate fifty acres extra.

A homesteader who has exhausted his homestead right and cannot obtain a pre-emption may enter for a purchased homestead in certain districts. Price \$3.00 per acre. Duties—Must reside six months in each of three years, cultivate fifty acres and erect a house worth \$300.00.

W. W. CORY,
Deputy of the Minister of the Interior
N.B.—Unauthorized publication of this advertisement will not be paid for.

Mention this magazine when writing advertisers

TACKS

WE ARE MANUFACTURERS OF ALL KINDS OF
Guaranteed Tacks and Small Cut Nails
ALSO MAKE A SPECIAL FEATURE OF
Brass Plating and Electro Tinning.
Write for Quotations to
Dominion Tack and Nail Co.,
Limited,
GALT, ONTARIO

Mention this magazine when writing advertisers

126 Chicks From 130 Eggs!

A 97% hatch! Mrs. Alma Shipp, Hale, Mo., did this with a Komon-Sense Incubator. Hundreds of others are doing likewise. So can you, because it's built right and heated right. It's durable and will last a lifetime with proper care. Think of it! This

Komon-Sense 130 Egg Incubator \$7.50
complete, with double-wafer regulator, high legs, deep nursery, egg-tester, lamp, thermometer and simple directions, all set up ready to run.

30 DAY FREE TRIAL
Hatches 90 per cent with least care and expense. Our customers' experience proves this.

Satisfaction guaranteed or no sale. 130-chick Komon-Sense Brooder alone, \$4.00. Incubator and Brooder ordered together, \$11.00. Order direct or send thought for Free Book.

Komon-Sense Incubator Co.
Box 74, Racine, Wis.

Incubator and Brooder \$10.50

Mention this magazine when writing advertisers

But here I reckoned without my hosts, it seems. Nor do I even now pretend to comprehend all that followed. For, all along, it seems that she understood Corson, and, even though his measure had grown to eccentric and giant proportions, she had comprehended every inch of it.

The very first intelligence she evinced after skirting the Valley of the Shadow was a whispered inquiry concerning him. And when I told her as gently as I could that I had had no news, her brow clouded for the merest instant with fearful apprehension; then an aureole of patience shrouded it, never leaving it, and she grew stronger by the hour.

It was early in the morning of the sixth day that he returned. A more unprepossessing and bedraggled bundle of humanity I never saw. It had rained during the night, which probably accounted for his mudstained clothes, which were ripped and torn in tatters as though from a struggle with wild beasts; he was hatless, and his hair was a tangled mass of wet locks; his face and hands were discolored with a bluish tinge that I knew to be powder burns, and on his clothes, and noticeably the back of his right hand, were dark red stains that explained themselves.

He had limped half-way across the room, where I sat eating a light breakfast, before I realized his purpose.

"Corson!" I cried, "you must not go in their yet—and looking like that!"

He turned round in a dazed fashion, but in that instant I saw the glint of victory flash from his keen eyes, and I knew that he had consummated that which he considered the greatest thing in the world. For a moment my loathing for the man was turned to involuntary admiration, for here was the most splendid figure of "the animal man triumphant" I ever hope to see. I noted, too, that he was on the verge of collapse from exhaustion and hunger.

"I've got to tell her," was his only comment, and before I could prevent it he had pushed noisily into the sick chamber. I could have shot the brute then and there.

I bounded in after him. He took his stand in the centre of the room, almost gibbering in his exuberance, while she, with luminous eyes, seemed to be waiting.

"Jennie—I'm famous!" he belated, pausing for breath at every few words. "They'll know me all over the country by tomorrow morning. For I went out alone and got him—the hound!—alone, and with bare hands: after he'd held the whole posse at bay for five hours I followed him into his

The Best Farm Lubricants

GRANITE Harvester Oil
A heavy, short-cut oil for farm machinery

Clings to the bearings and insures the least possible friction and wear. Moisture and changes of temperature do not affect it. The choice of the most successful farmers.

STANDARD Gas Engine Oil

Used and recommended by the leading engine builders all over the country. Keeps its body at high temperatures. Equally good for external bearings.

El Dorado Castor Machine Oil Silver Star Engine Kerosene
Capitol Cylinder Oil Imperial Motor Gasoline
Thresher Hard Oil Mica Axle Grease

Stock carried at 300 tank and warehouse stations in Western Canada. For addresses, price lists, etc., write any agency.

THE IMPERIAL OIL COMPANY, Limited
Main Office: **WINNIPEG**
Regina, Moose Jaw, Saskatoon, Edmonton
Calgary, Lethbridge, Vancouver

You saw this advertisement in this magazine. Don't forget to say so when writing.

FOR THE SIXTH SUGGESTIVE YEAR

The Great-West Life Stands FIRST of all the Companies for Canadian Business in 1912.

There are the best of reasons for this prominence. Many sound "reasons" are given in the new booklet "PROFITS 1913"—a record of RESULTS TO POLICYHOLDERS.

Ask for a copy and for personal rates

The Great West Life Assurance Company
Head Office: WINNIPEG.
Over \$83,000,000 of business now in force.

You saw this advertisement in this magazine. Don't forget to say so when writing.

Family Group Photos a Specialty

AT
STEELE & CO., LTD.
MAIN ST. AND BANNATYNE AVE. WINNIPEG

You saw this advertisement in this magazine. Don't forget to say so when writing.

PEERLESS PERFECTION



The Fence That's Locked Together

It's close enough to keep small fowl in and strong enough to keep large animals out. Securely locked together at each intersection of the wires. It's many times heavier and stronger than poultry netting, and being well galvanized, will last many years longer. Top and bottom wires are extra heavy. No top and bottom boards required. PEERLESS Poultry Fence is built so strong and heavy, that but half the ordinary number of posts are required. It gives you real fence service.

Here's How Strong It Is

Read this Letter

Dear Sir: I am writing a testimonial as to the strength of PEERLESS Junior Chicken Fencing. Mine is four feet high. It turns two horses each weighing 1600 pounds. They ran full tilt into the fence about 2 rods from each other at the same time. The result was that they both received a concussion over the fence, alighting on their heads and necks, scratching them up some, but the fence remained intact.

Yours truly,
Barry Carter, R. C. Jas. Boothford

Think of it—a poultry fence strong enough to withstand the combined weight of two big horses. And that without a top or bottom board either. If you are interested in such fencing, write us. Ask for our literature. We also manufacture farm fence and ornamental gates.

Agents nearly everywhere. Live agents wanted in unassigned territory.

The Banwell-Hoxie Wire Fence Co., Ltd.
Winnipeg, Man. Hamilton, Ont.

lair! He got me in the leg, then in the shoulder—and then I got hold of him! Heaven, how I—”

Here he screwed up his emaciated face into a hideous expression as he lived over again the terrific struggle. I tried to interpose.

“You fiend!” I whispered in his ear, trying in vain to push him from the room. “You’ll kill her, I say. Don’t you know that she nearly died while you were away?”

“Wait till I finish, won’t you!” he growled, shoving me violently aside. “Well, Jennie, I got him by his throat—he struck me with his knife, I grabbed it from him, and—and—”

Something seemed to have burst in his brain, and I feared a collapse.

His whole attitude, which had been that of choking a man to death, suddenly changed. He began to tremble violently.

“By heaven!” he said, hoarsely, passing his hand over his eyes, and looking about him in a startled fashion as though he had just awakened from a terrible nightmare in which he had unwittingly committed many crimes and now looked on the deeds in horror. Then I saw that his eyes had followed hers to the baby that lay in a basket beside her.

His brutal triumph, his gibbering tale, his dark deeds paled in the wonderful brightness of this mystery, which for the first time penetrated his own selfish career and brought his nature forward a thousand years again.

He looked from the child to the woman, his face working with the strong emotions of a man undone, and when he saw her wonderful eyes more benign than triumphant, he seized the edge of the bed and sank down in sheer weakness, sobbing, but tearless.

“Oh, Jennie, Jennie,” he sobbed. “To think of me—I, who owe everything to you, even life—deserting one to go and rob a poor devil of the other. I was set upon thrusting a life out of the world, while you offered your life to bring another into it—oh! dearest, that is the greatest thing in the world.”

The doctor paused, and for a moment the four men seemed to be lost in deep meditation.

“This has filled me with a hope of health I never dared cherish,” said Belclair, gratefully. “And, further than that, it has solved a question that has often presented itself to me for solution: What are the primitive impulses and motives in the character of man and woman.”

“According to that, then, the primitive nature of one seems bent on slaying, the other on preserving life, doesn’t it?” said the doctor.

“Exactly—the Corsons are the man and the woman of all ages.”

CHALLENGE GOLLARS



Save you money

Stop all laundry troubles. “Challenge” Collars can be cleaned with a rub from a wet cloth—smart and dressy always. The correct dull finish and texture of the best linen. If your dealer hasn’t “Challenge” Brand write us enclosing money, 25c. for collars, 50c. per pair for cuffs. We will supply you. Send for new style book.

THE ARLINGTON CO. OF CANADA
Limited
54-64 Fraser Ave., Toronto, Can.
8149

AUSTIN Well Digging and Prospecting Machinery

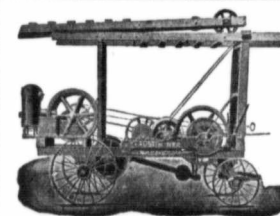

Rock Drilling, Hydraulic Jetting, or Hydraulic Rotary Machines to drill any depth in any formation. Operated by steam or gasoline engines, or horse power.

Write for Illustrated Catalogue No. 15.

AUSTIN MANUFACTURING COMPANY,
CHICAGO.

Canadian Sales Agents—**BURRIDGE COOPER CO., LTD.,** Winnipeg

REGISTERED TRADE MARK

JOSEPH RODGERS & SONS, Limited
SHEFFIELD, ENG.



Avoid imitations of our CUTLERY by Seeing that This EXACT MARK is on Each Blade.

SOLE AGENTS FOR CANADA

JAMES HUTTON & CO., MONTREAL

THE Double Track Route

GRAND TRUNK RAILWAY SYSTEM

TO
Detroit, London, Hamilton, Toronto, Montreal and New York via Niagara Falls

Smooth road-bed, polite employees, unexcelled dining-car service, and latest standard equipment

AGENTS, COOK'S TOURS AND ALL STEAMSHIP LINES

Rates, reservations and all particulars at Ticket Office

Phone Main 7098 260 Portage
WINNIPEG

CHEW MAPLE SUGAR TOBACCO

MILD, SWEET, MELLOW AND JUICY

Manufactured by
ROCK CITY TOBACCO CO.
Quebec Winnipeg



Waterloo MFG. CO. LTD.

SEPARATORS, WIND-STACKERS, FEEDERS, BAGGERS, ETC.

Waterloo Lion Brand

of Farm Machinery has never yet been surpassed by anything in Agricultural Engineering for quality, efficiency, durability and value. Plowing and Threshing Engines ranging from 14 to 30-H.P. are unsurpassed by anything of their size. Wind Stackers, Feeders, Baggers and Drive Belts a specialty.

Waterloo Separators
28-42 to 36-56

ARE THE GREATEST GRAIN SAVERS IN THE MARKET

The “Champion” Made in 2 sizes
28x42 33x52 36x56

Write for catalogue of complete line

Waterloo Manufacturing Co. Ltd.

FACTORY BRANCH OFFICE AND WAREHOUSE
WATERLOO-ONT. PORTAGE LA PRAIRIE MAN.

You saw this advertisement in this magazine. Don't forget to say so when writing.

3

Leading Brands

Sold everywhere throughout
Western Canada

DREWRY'S

Refined

Ale

(Registered)

Extra Stout

AND

Redwood

Lager

These well known malt
beverages are brewed from
barley malt and hops only.
Always uniform in quality and
flavor.

Mention this magazine when writing advertisers

WE WANT AGENTS

Everywhere in Western Canada

for
C.O.W.L. Brand Ranch & Farm
Remedies. (Preparations made from
refined Coal-Tar and blended with
suitable emolient oil).

Liberal Commissions
Full particulars, prices etc., on application.

The Carbon Oil Works, Limited
WINNIPEG CANADA
Write to Dept. "T" Remedies.

Mention this magazine when writing advertisers

**Dealers Increase
Your Sales!**

Take a Look at the
Strite Governor Pulley

It's the original and the
only thing for driving cream
separators with gasoline en-
gines—Once tried, always
used. TRY ONE. More in use
than all others combined.
Costs no more than imita-
tions. Also, ask about our
friction clutch pulleys.

STRITE GOVERNOR PULLEY CO., 310 S. 3RD ST., MINNEAPOLIS
Mention this magazine when writing advertisers

**PATENTS TRADE MARKS
AND DESIGNS**

Write for booklet, circulars, terms, etc.

FETHERSTONHAUGH & CO.
FRED. B. FETHERSTONHAUGH, F. C. M. E.
GERALD S. ROXBURGH, B. A. Sc.
Portage Avenue, WINNIPEG,
209-10 Bank of Nova Scotia

Mention this magazine when writing advertisers

In Answering Advertisements
in this Magazine be sure and mention
where you saw the advt. Remember
we guarantee the reliability of all
our advertisers.

Enough to Make a Cat Laugh



The Verdict

It was the first case ever tried in Stony Gulch, and the jury had sat for hours, arguing and disputing over it, in the bare little room at the rear of the court-room. At last they straggled back to their places, and the foreman, a tall mountaineer, voiced the general opinion.

"We don't think he did it," he said slowly, "for we allow he wa'n't there; but we think he would ef he'd had the chanst."

The New Judge

A new Missouri judge arose to charge the jury, and spoke as follows:

"Gentlemen of the jury: charging a jury is a new business to me, as this is my first case. You have heard all the evidence as well as myself. You have heard what the learned council has said. If you believe what the council for the plaintiff have told you, your verdict will be for the plaintiff; but if, on the other hand, you believe what the defendant's counsel has told you, then you will find a verdict for the defendant. But if you were like me, and don't believe what either of them said, then I'll be d—d if I know what you'll do. Constable, take charge of the jury."

Held Up

A suburban train was slowly working its way through one of the blizzards of '94. Finally it come to dead stop and all efforts to start again were futile.

In the wee, small hours of the morning a weary commuter, numb from the cold and the cramped position in which he had tried to sleep, crawled out of the train and floundered through the heavy snow-drifts to the nearest telegraph station. This is the message he handed to the operator:

"Will not be at office today. Not home yesterday yet."

National Trust Company, Ltd.
TORONTO, WINNIPEG, EDMONTON, MONTREAL, REGINA, SASKATOON
Capital and Reserve, \$2,800,000.00

The strain and worry of managing Estates will all be borne for you by this Company.

A PRIVATE Executor may die or become incapable of acting before the completion of the Trust. A Trust Company is PERMANENT and will survive the longest Trusts.

This Company's financial strength and expert staff ensure responsible and capable administration.

We act as Trustee, Executor, Administrator, Guardian, Liquidator, Assignee, Financial Agent

SAFE DEPOSIT VAULTS SAVINGS DEPARTMENT MONEY TO LOAN
D. H. COOPER, Manager, Winnipeg Branch, 323-325 Main St.

You saw this advertisement in this magazine. Don't forget to say so when writing.

— FIRE INSURANCE —

The Liverpool-Manitoba Assurance Co.

All Policies Guaranteed by

THE LIVERPOOL AND LONDON AND GLOBE INSURANCE COMPANY, LTD.

Northwest Branch - WINNIPEG, Canada
S. N. RICHARDS, Local Manager

You saw this advertisement in this magazine. Don't forget to say so when writing.

The Occidental Fire Insurance Co.
Head Office: WAWANESA, MAN.

A. NAISMITH, President R. M. MATHESON, Vice-President
A. F. KEMPTON, Sec. and Mgr. C. D. KERR, Treasurer

Subscribed Capital \$500,000.00
Security to Policy-holders 640,817.29

Full Deposit with Dominion Government
Agents wanted in unrepresented districts

You saw this advertisement in this magazine. Don't forget to say so when writing.

Alex. Naismith, Pres. Wm. Paterson, Vice-Pres. C. D. Kerr, Treasurer

The WAWANESA MUTUAL INSURANCE COMPANY
HEAD OFFICE: WAWANESA, MAN.
A. F. KEMPTON, Secretary-Manager

Amount of Insurance in force Dec. 31st, 1911 \$31,243,598.00
Assets over Liabilities 522,944.15

THE NUMBER OF FARMERS INSURED 21,543

The Largest Farmers Mutual Fire Insurance Company in Canada. Agents wanted in unrepresented districts

You saw this advertisement in this magazine. Don't forget to say so when writing.

INSURANCE—INSURANCE
FRED W. PACE F. J. L. HARRISON F. GRANT MILLAR

PACE, HARRISON & MILLAR
Keewayden Building - Portage Ave., East

General Agents:

NATIONAL FIRE INSURANCE COMPANY of Hartford, Conn. Assets Exceed \$12,000,000.00	GENERAL FIRE ASSURANCE COMPANY of Paris, France. Assets Exceed 7,500,000.00
--	---

Adjustment and payment of losses arranged from our office. Liberal contracts to live agents. WRITE FOR AGENCY.

You saw this advertisement in this magazine. Don't forget to say so when writing.

125-Egg Incubator and Brooder Both For \$13.75

If ordered together we send both machines for only \$13.75 and we pay all freight and duty charges to any R. R. station in Canada.

We have branch warehouses in Winnipeg, Man. and Toronto, Ont. Orders shipped from nearest warehouse to your R. R. station. Hot water, double walls, dead-air space between, double glass doors, copper tanks and boilers, self-regulating. Nursery under egg tray. Especially adapted to Canadian climate. Incubator and Brooder shipped complete with thermometers, lamps, egg testers—ready to use when you get them. Five year guarantee—30 days trial. Incubators finished in natural colors showing the high grade California Redwood lumber used—not painted to cover inferior material. If you will compare our machines with others, we feel sure of your order. Don't buy until you do this—you'll save money—it pays to investigate before you buy. Remember our price of \$13.75 is for both Incubator and Brooder and covers freight and duty charges. Send for FREE catalog today, or send in your order and save time.

Write us today.
Don't delay.

WISCONSIN INCUBATOR CO., Box 224, Racine, Wis., U. S. A.

You saw this advertisement in this magazine. Don't forget to say so when writing.

EUREKA HARNESS OIL

BEST FOR WEAR

Insist on the genuine Eureka Harness Oil in original packages.

Dealers Everywhere

THE IMPERIAL OIL CO., LIMITED

You saw this advertisement in this magazine. Don't forget to say so when writing.

Well Drilling Machines

Over 70 sizes and styles, for drilling either deep or shallow wells in any kind of soil on wheels or on glides or horns.

With en-powers, strong, simple, durable. Any mechanic can operate them. Send for catalog.

WILLIAMS BROS.,
ITHACA, N. Y.

Mention this magazine when writing advertisers

Imperial Bank

OF CANADA
Established 1876

Capital Authorized \$10,000,000
Capital Paid Up 6,620,000
Reserve Fund 6,620,000
Total Assets 72,000,000

BRANCHES IN WESTERN CANADA

Province of Manitoba
Brandon Portage la Prairie Winnipeg

Province of Saskatchewan
Balgonie Broadview North Battleford
Rothern Fort Qu'Appelle Prince Albert
Saskatoon Moose Jaw Regina
Wilkie Hague Wynyard

Province of Alberta
Athabaska Landing Edmonton Strathcona
Banff Lethbridge Wetaskiwin
Calgary Red Deer Redcliff
Rocky Mountain Hse. Medicine Hat Millet

SAVINGS DEPARTMENTS AT ALL BRANCHES

Interest allowed at Current Rates
Drafts and Letters of Credit issued available in all parts of the world.

Winnipeg Branch
N. G. LESLIE, Manager.

Mention this magazine when writing advertisers

The Pump That Pumps
Double-acting Lift, Tank and Spray
SPRAY PUMPS
PUMPS
Meyers HAY TOOLS
I Glass Valve of all kinds. Write for Circulars and Prices.
Meyers Stayon Flexible Door Hangers
with steel roller bearings, easy to push and to pull, cannot be thrown off the track—hence its name—“Stayon.” Write for descriptive circular and prices. Exclusive Agency given to right party who will buy in quantity.

Advised. Ochs

Mention this magazine when writing advertisers

Erickson Leg

Does not chafe, overheat or draw end of stump. Sent for Catalog.

Arms, Crutches, Stockings,
SOLD ON EASY TERMS.
E. H. Erickson Artificial Limb Co., Largest Limb Factory in World.
16 Wash. Av. So., Minneapolis, Minn.

Mention this magazine when writing advertisers

PEERLESS FARM FENCE

Made of the best galvanized open hearth steel wire. Wire interlocking locked in place with our lock clamps. Every rod guaranteed. Sent for Catalog. Agents wanted in open territory.

RANWELL-BROKE WIRE FENCE CO., LTD.
WINNIPEG, Manitoba HAMILTON, Ontario

Mention this magazine when writing advertisers



THE ORIGINAL PECH Boring Machine
THE OLD RELIABLE
Easiest to operate Bores Faster Most Durable

Improved Up-to-date Drilling Machines
DESCRIPTIVE CATALOGUE FREE
Cherokee Mfg. Co., Dept. A. Cherokee, Iowa.

Mention this magazine when writing advertisers

ERZINGER'S No. 2 CUT PLUG

Leads them all. It's the Best Dollar Tobacco sold anywhere.

JOHN ERZINGER
McIntyre Bldg. - 293 Portage Ave.
Phone 69 Phone 2677

Mention this magazine when writing advertisers

Mayor Dunne, of Chicago, recently visited a barber shop where the barber, failing to recognize him, was very talkative.

"Have you ever been here before?" he asked.

"Once," said the mayor.

"Strange that I don't recall your face."

"Not at all," the mayor assured him. "It altered greatly in healing."

Pay For No Trimmings



Thrifty Scot, on a visit to the City—"That's a big price for afternoon tea. Bid ye, wumman, an' I'll see what they'll charge without the band."

Perfectly Satisfied

A college professor, noted for his concentration of thought, returned home from a scientific meeting one night, still pondering deeply upon the subject that had been discussed. As he entered his room he heard a noise that came from under the bed.

"Is there some one there?" he asked absently.

"No, professor," answered the intruder, who knew his peculiarities.

"That's strange," muttered the professor. "I was almost sure I heard someone under the bed."

He Knew the Animal

The fifth day drew to its close, with the twelfth juryman still unconvinced. The court was impatient.

"Well, gentlemen," said the court officer, entering the jury-room, "shall I, as usual, order twelve dinners?"

"Make it," said the foreman, "eleven dinners and a bale of hay!"

Man wants but little here below,
As someone said before,
But when he gets it, don't you know,
He wants a little more.

Barber (to customer)—Positively, I am unlucky today. The omens are all against me. You are the thirteenth customer I have gashed since morning.

WINCHESTER



THE NEW WINCHESTER

MODEL 1912 20 GAUGE TAKE-DOWN Hammerless Repeating Shotgun

The lightest, strongest and handsomest repeating shotgun made. It weighs only 5 1/2 pounds, yet, all metal parts being made throughout of Nickel Steel, it has wonderful strength. In grace of outline and refinement of detail and finish, it is unapproached by repeating guns of other makes. It is exceedingly simple to load, unload and take down, and shoots with the strength and accuracy for which Winchester guns are noted.

Ask your dealer to show you one, or send to Winchester Repeating Arms Co., New Haven, Conn., for handsome, illustrated circular describing it.

A 20 GAUGE GUN FROM BUTT TO MUZZLE.

You saw this advertisement in this magazine. Don't forget to say so when writing.

IF YOU are at all interested in Home-Mixed Fertilizers

I would like to send you my book on the subject. It contains formulas and plenty of information for farmers who want to get the most and the best for their money. The book will be sent free upon request.

Dr. William S. Myers
Director Chilean Nitrate Propaganda
17 Madison Ave., New York
No Branch Offices

You saw this advertisement in this magazine. Don't forget to say so when writing.



If You Value Your Eyesight

You will equip your reading table with a **Rayo Lamp**

Authorities agree that a good kerosene oil lamp is the best for reading. The Rayo is the best oil lamp made—the result of years of scientific study. It gives a steady, white light, clear—mellow. Made of solid brass, nickel plated. Can be lighted without removing chimney or shade. Easy to clean and rewick.

At Dealers Everywhere.

THE IMPERIAL OIL COMPANY, Limited
WINNIPEG MONTREAL TORONTO ST. JOHN HALIFAX

You saw this advertisement in this magazine. Don't forget to say so when writing.

Patronize Those Who Patronize This Magazine

THE BEST LINIMENT

OR PAIN KILLER FOR THE HUMAN BODY

**Gombault's
Caustic Balsam**
IT HAS NO EQUAL

For the Human Body

It is penetrat- ing, soothing and healing, and for all the sores, Bruises of Wounds, Felons, Interior Cancers, Boils, Corns and Bunions. CAUSTIC BALSAM has no equal as a Liniment.

We would say, to all who buy it that it does not contain a particle of poisonous substance and therefore no harm can result from its external use. Persistent, thorough use will cure many old or chronic ailments and it can be used on any case that requires an outward application with perfect safety.

Perfectly Safe and Reliable Remedy for Sore Throat Chest Cold Backache Neuralgia Sprains Strains Lumbago Diphtheria Sore Lungs Rheumatism and all Stiff Joints

REMOVES THE SORENESS—STRENGTHENS MUSCLES
Cornhill, Tex.—"One bottle Gombault's Balsam did my rheumatism more good than \$150.00 paid in doctor's bills."
OTTO A. BEYER.
Price \$1.50 per bottle. Sold by Druggists, or sent by express prepaid. Write for Booklet B. The LAWRENCE-WILLIAMS COMPANY, Toronto, Can.

Mention this magazine when writing advertisers.



\$1500 to \$5000 Per Year

have been made by hundreds of people operating the "American" Drilling Machines. 40 years' experience, 59 reg- lar styles and sizes and the output of the world's largest manu- facturers of this kind of machinery make

"AMERICAN" MACHINES STANDARD

Made in types for every kind of earth and rock drilling or mineral prospecting, equip- ped with any power, or oper- ated with your traction en- gine. Our new 186 page Catalog Free.

THE AMERICAN WELL WORKS

General Office and Works:
AURORA ILL., U.S.A.

Chicago Office: First Nat. Bk. Bldg.

Mention this magazine when writing advertisers

MAKE YOUR OWN TILE



Cost \$4.00 to \$6.00 Per 1,000

Hand or Power

Send for Catalog

FARMERS' CEMENT TILE MACHINE CO. WALKERVILLE, ONT.

Mention this magazine when writing advertisers

Food for Quiet Hours

Reputation is the outward man; character is as the very life.

Read fiction as you eat pastry; not for the whole meal, but as a pleasant addition.

Nothing keeps a man from knowledge and wisdom like think- ing he has both. Sir W. Temple.

Better to be alone in the world, and utterly friendless than to have sham friends and no sympathy.

Happiness consists in activity. Such is the constitution of our nature; it is a running stream, and not a stagnant pool. Goode.

Cleverness, talents, elegant manners, graceful speech, and winsome ways; are nothing unless they are protected by the shield of firmness.

Men's lives should be like the days, more beautiful in the even- ing; or like seasons aglow with promise, and the autumn rich with golden sheaves, where good words and deeds have ripened on the field.

Loss takes a man's character to pieces, fibre by fibre and shows him what he is made of. Prosperity takes a man to the edge of a great cliff, and proves whether he be a giddy adventurer, or a wise pilgrim. Dr. Parker.

Censure and criticism never hurt anybody. If false, they cannot harm you, unless you are wanting in character; and if true, they show a man his weak points, and forewarn him against failure and trouble. Gladstone.

We should wear the garment of praise on the most commonplace of days. It should be the peasant's frock, and the merchant's coat, the lady's dress, and the servant's gown. It is the best for wear, for comfort, and for beauty, and it never gets out of fashion. Spurgeon.

Restraint

We know nothing and can know nothing of a disembodied life. Energy becomes efficient by limitation. Watts first confined and then directed the energy of steam. We cannot use the energy of the tides because we cannot control or imprison them. Think, then, of thy body as God's special gift for power. Young men who think that the ideal condition is one of untrammelled freedom need to bear in mind the parable of the steam, which is strong only when it is kept in restraint.



Horse-power and dollar- power find maximum work- ing power in the Ford. Winter's bad roads have few terrors for the Ford— because it has more power for its weight than any other car. An order now insures an early delivery.

Think of it—nearly 200,000 Fords have been sold and delivered. New prices —runabout \$675—touring car \$750—de- livery car \$775—town car \$1000—with all equipment, f.o.b. Walkerville, Ont. Get particulars from Ford Motor Company of Canada, Limited, Walkerville, Ont., Canada.]

SEEDING THAT FROST AND HAIL DO NOT AFFECT

NOW IS THE TIME TO PLANT YOUR GOLDEN SEED

A few dollars planted now in our high class property will pro- duce a rich harvest when other crops may fail. We are offering lots in our "Deer Lodge Subdivision" situated in the West End and adjoining Portage Avenue, where a five-cent car fare will carry you right to the property and in our "Woodlawn Subdivision" situated in the south- east of the City, at original prices.

So assured are we that prices will increase rapidly and good prof- its result, that we will guarantee to refund your money with six per cent per annum added, if at the end of two years you are not satisfied with your investment. Can anything be fairer than this?

Write for plans and full particulars.

PRICES LOW TERMS EASY

STEWART & WALKER LIMITED
202 STERLING BANK BLDG. WINNIPEG

You saw this advertisement in this magazine. Don't forget to say so when writing.

The 'BANNER' Cold Blast Lantern



Perfect Adjustments Handsome Appearance Very Large Well Patent Lift Lock We Invite Comparison Costs No More Than Inferior Lanterns

If your dealer doesn't stock them—write

Ontario Lantern & Lamp Co., Limited
Hamilton, Ontario

You saw this advertisement in this magazine. Don't forget to say so when writing.



Conducted for the benefit of Dealers, Threshermen and Farmers who have anything to sell or exchange. Three cents a word for each insertion.

MACHINE SHOPS. Practical machinist with position, manager or otherwise. Country town. Expert gasoline engine, automobiles. Business experience. Place where business could be taken over or partnership arranged later would suit. Address 1208 Alexander Ave., Winnipeg.

POSITION WANTED—Spring till winter driving gasoline engine. Rummly preferred, experienced electricity and gasoline plowing on prairie. Good character, abstainer, work long hours if necessary. Reply stating wages offered. Engineer, care Canadian Thresherman.

WANTED—Position as Engineer on a steam traction outfit. Fully experienced. Can furnish references. Address J. E. Peatch, Clava, Man.

SALESMEN WANTED—Threshermen or engineers to sell oils, greases, belts, packing, lacing, paints, etc. First class opportunity for first class men. O. L. Doty, Cleveland, Ohio.

SALESMEN—are drawing two to six hundred dollars per month. Traveling with their own teams. Selling oil, Lubricants, Oils, Greases, Paints and Specialties, direct to the consuming trade. Now is the time to take orders for gas and oil and spring delivery. Inland Oil Works Company, Winnipeg, Canada.

FOR SALE—4-55 B.H.P. 2-cylinder gasoline engine and 5-horse gang plow. Used one season; good reasons for selling. E. Schroeder, Hanley, Sask.

FOR SALE—A Cuddy steering device for a 20 H. P. International gasoline engine. Device only used two days. Terms: \$70 Cash, purchaser's shipping point. S. Melville Webb, Sunny Isle, Sask.

WANTED—Live salesmen in every good town and district in Western Canada to sell our Hardy Tested Nursery Stock. Highest commissions paid. Exclusive territory. Equipment free. Canada's greatest Nurseries. Stone & Wellington, Toronto.

FOR SALE—Cook of the North engine, 22 H. P. This engine is in perfect order and nearly new. Apply to E. Hear, Keyes, Man.

FARMS WANTED. We have direct buyers. Don't pay commissions. Write describing property, naming lowest price. We help buyers locate desirable property free. American Investment Association, 15 Palace Bldg., Minneapolis, Minn.

DO YOU WANT city houses or lots for your farm, or lots in other districts for your present home site? We have the best equipped and the most efficient exchange department in the city. We can get you property anywhere in the Dominion for what you have and can effect an exchange for you within a few days time. Thorndast, Reed & Lillholm, 645 Main St., Winnipeg.

WANTED—Strictly high class gas tractor salesmen for Minnesota, Nebraska, North and South Dakota, Montana and Western Canada. Permanent and attractive proposition to live salesmen that can make good. Address c/o Canadian Thresherman, Winnipeg, Man.

MARQUIS WHEAT—Won the world's championship again this year. It was grown from seed supplied by me. Get some of the big, strong seed that has proved its superiority. Make sure of it now. Money back guarantee. Sample and special price on request. Harris McAvayden, Farm Seed Expert, Winnipeg, Man.

STEAM PLOWMEN—Look! Good section of 11 steam plow land on C.N.R., Saskatoon-Regina line in Twp. 23, R. 26. Level—free from wind or stone. Clear title—only \$16 per acre, \$4 cash balance in 1, 2 and 3 years. This is exceptional. For further particulars, write S. O. Cronie, 12 Bank of Hamilton, Winnipeg.

FOR SALE

We have on hand at present a very full line of Rebuilt and Second-hand Engines and Separators who we are offering at attractive prices. Write us today what you are thinking of buying, when we shall be pleased to tell you what we have and quote prices. All our rebuilt goods are sold under same guarantee as new ones and of course are carefully inspected and look exactly like new. If you write us once we are sure to have the size you most want.

We also have a thoroughly Rebuilt 25 H. P. Saw Mill Engine. Can hardly be distinguished from new goods. Will be sold at a bargain.

SAWYER-MASSEY COMPANY LIMITED Winnipeg, Man.

BUYERS, ATTENTION! THE GEORGE WHITE & SONS COMPANY, LIMITED, BRANDON, MAN.

- ENGINES
2-25 H.P. White tractions thoroughly rebuilt and in good shape. Each \$160.00
1-16 H.P. American Advance tractor \$700.00
1-18 H.P. Minneapolis traction, \$600.00
1-20 H.P. Brasilia Corson, Each \$4000.00
1-20 H.P. White traction, \$1200.00
SEPARATORS—Second Hand
1-Aultman & Taylor, 28x50, all attachments, \$400.00
1-40x62 Waterloo separator, all attachments, \$400.00
1-30x60 Goddison separator, all attachments, \$300.00
1-30x60 American Shell all attachments, \$325.00
1-30x56 Fishie separator, all attachments, \$300.00
2-32x56 Great West separator, all attachments, \$200.00
1-30x56 Great West separator, all attachments, \$200.00
2-White Challenge separators, thoroughly rebuilt, all attachments. Each \$90.00
Write us re new goods—We have the best.

HOW TO START YOUR GAS ENGINE in the coldest weather, first clip. No hot water, (save time.) Formula No. 1. P.S. For your information—This Formula is a liquid, very high explosive, will evaporate in coldest weather. I use it myself at all times in cold weather. J. W. BARRON, 2112 Louise, Brandon

BARGAINS

- 1-32 H.P. Port Huron engine, rebuilt and in first class shape.
1-American-Abell 20 H.P. engine, rebuilt.
1-Minneapolis Separator 4x172, rebuilt. With all connections.
1-32x54 Avery Separator complete, just rebuilt.
1-30x60 Avery Separator to be rebuilt complete.
2-very 30 H.P. double undermounted engines.
1-30 H.P. Northwest engine, not rebuilt, cheap
1-J. I. Case steel, 42x60 separator complete with all attachments.
1-2470 Avery separator, will be rebuilt in time for next fall's work.
If you are interested in second hand goods please write and let us know what you want as we are making deals almost every day, and feel sure that we can fix you out with almost anything you want, either in new or second hand goods. HAUG BROS. & NELLEMOE Co. Ltd. WINNIPEG.

GASOLINE TRACTOR FOR SALE—I have a first class 30 H. P. Gasoline Tractor for sale. This Tractor is manufactured by Kincaid-Haines, Minneapolis, whose Gas Tractors have carried off two Diplomas and first class prizes at Agricultural Fairs than any other Tractor sold in Western Canada. Having disposed of my farm, I will sell this Tractor right. Buy now, so as to have use of it for thrashing season. Write for particulars, Address W. D. Weedy, Brandon, Manitoba.

FOR SALE

- No.
15 Horse Case Simple Portable Engine..... 20540
15 Horse Case Simple Portable Engine..... 18883
15 Horse Compound Portable Engine..... 13420
18 Horse Simple Traction Waterloo..... 323
18 Horse Portable Sawyer-Massey..... 5299
20 Horse Portable Sawyer-Massey..... 5419
20 Horse Simple Traction Sawyer-Massey..... 1116
20 Horse Compound Traction Engine, Case..... 1721
20 Horse Simple Traction Engine, Case..... 16912
32 Horse Simple Traction Engine, Case..... 19019
F. J. CASE, THRESHING MACHINE COMPANY, WINNIPEG, CANADA.

FOR SALE—One 65 horse power Marshall gasoline tractor, thoroughly overhauled and in first class condition. G.S.C. Box 3078, Winnipeg.

WANTED — SALESMEN AND SALESWOMEN—Hundreds of good positions now open paying from \$1,000.00 to \$5,000.00 a year. No former experience required to get one of them. We will teach you to be a high grade Traveling Salesman or Saleswoman by mail in eight weeks and assist you to secure a good position where you can earn good wages if you are learning Practical Salesmanship. Write today for full particulars and testimonials from hundreds of men and women we have recently placed in good positions; also list of good positions open. Address Dept. K. NATIONAL SALESMEN'S TRAINING ASSOCIATION, 806 Kent Building, Toronto, Ont.

Mention this magazine when writing advertisers.

OR SALE—Gas Traction engine, 25 horse power. In good condition, all ready to run. A snap, as I am going out of business. A. D. Danison, Dalnida, Sask.

WANTED—Positions as engineers on Rumely Oil Pull and Hart-Parr gasoline engines, by two parties. Address R. J. Sharp, Cotton Wood, Sask.

FOR SALE—One 30-in. Sawyer-Massey separator, one 30-in. Bell City separator, both with wind stacker and high bagger, in good shape. Would exchange for farm stock, motor car, straw cutter, hay press, etc.. C. D. Grant, Ituna, Sask.

BRED FOR EGGS AND MEAT—Bellevue Strain of White and Columbian Wyandottes, S. C. White Leghorns and Light Brahmas. Stock for sale. Over 30 years in business. Michael K. Boyer, Box 22, Hammonont, Atlantic County, New Jersey.

WANTED—Good engine for plowing. Have first class tractor section to exchange half mile from prosperous town. P.O. Box 189, Estevan, Sask.

POSITION WANTED AS FIREMAN—Steam plow, three seasons firing thrashing engine. Avery preferred. Good knowledge of gasoline engines. Write Box 3079, Canadian T. & F., Winnipeg, Man.

FOREMAN wishes to take care of big farm, first class work guaranteed. Address: Jilly Brown, Wilcox, Sask.

WANTED—Position on a gasoline or kerosene engine, must be 30 or 40 horse power, also steady run. Seven years experience. Can do repair work. Best references. Apply stating wages' size and make of Engine to: J. H. Hislop, Pelly, Sask.

WANTED NOW—For Western Trade—If liable men only, to sell our well-known lines of fruit and ornamental trees, shrubs, special potatoes, etc. Outfit free. Exclusive territory, pay weekly; whole or part time engagements. Write terms for winter months. Pelham Nursery Co., Toronto.

EXPERIENCED ENGINEER wishes position for coming season on steam plowing outfit, strictly temperate and reliable, can furnish references, apply stating wages. D. McDonald, Red Jacket, Sask.

FOR SALE—110 horse power Case engine 40x62 Case separator. Eight furrow Cokerhutt plow. Water tanks and caboose. Bargain. Write at once to: F. W. Hunter, Box 172, Stonewall, Man.

FOR SALE—One 30-60 horse power gas tractor, new, and one nearly new 8-bottom Cokerhutt plow. These are in Canada and will be sold at a bargain. Address: R. A. Caswell, Cherokee, Iowa, U.S.A.

45 VARIETIES, poultry, pigeons, ducks, geese, Incubators. Feed and supplies. Catalogue 4 cents. Missouri Squab Co., Kirkwood, Mo.

FOR SALE—Large Wind Mill and Stock Pump for 40-foot well; 20-foot Four Standard Steel Tower; 12-foot Wheel. Apply Purvis Bros, Box 1, Holland, Man.

FLOWING OUTFIT—Having sold my farm, I offer my 45 H. P. International 'Twin Cylinder Gasoline-Kerosene Tractor, with extension rims and belt pulley complete; also 8-furrow New Oliver Gang, with mold board and red bottoms, and 3 sets of shares, 1912 improvement; outfit in first class condition; cost, with new cook car, \$4000.00; will sacrifice for \$3000.00, has broken but two sections of land. Apply Wm. Anderson, 2262 Smith St., Regina.

WANTED POSITION on either steam or gas tractor for season of 1913. Have had several years experience. Can do own repairing. Strictly temperate. Address E. C. Winchester, Melita, Man.

FOR SALE—Big 'Dutchman' Engine Gang—six new breaker bottom, with extra sharp and standard. A bargain for cash. W. S. Mearns, Cut Knife, Sask.

FOR SALE—One 30 H.P. undermounted Avery Engine and ten-bottom Cokerhutt plow. Or will trade for land, livestock, or gasoline Engine. For particulars address P. O. Box 1830 Lethbridge, Alta.

WANTED—Position as engineer for steam or gasoline engine for plowing, etc.—Saskatoon 1913. R. J. C. Box 3079, Winnipeg.

FOR SALE—International 20 H.P. gasoline tractor with 4-bottom P. & O. Breaking Plow. Also Aultman Taylor New Century Separator, size 27x42 In first-class condition. Has done one season's work. Price and terms reasonable. Apply E. T. Hargreaves, Enfield, Sask.

WE DUPLICATE ALL INFERTILE EGGS. White and Columbian Wyandottes, Single Comb White Leghorns and Light Brahmas. We use trap nests. In business for 30 years. Branch eggs, \$3 for 15; \$5 for 30. The other varieties \$2 for 15; \$3 for 30, \$10 for 100. Address, Michael K. Boyer, Box 22, Hammonont, New Jersey.

You saw this advertisement in this magazine. Don't forget to say so when writing.



There Is No String To This Pipe

It is absolutely FREE to subscribers who take advantage of this offer

The Weekly Free Press and Prairie Farmer Winnipeg The Canadian Thresherman and Farmer

Both including Pipe for the nominal sum of \$1.25

The lowest price at which these two papers will be offered this year is \$1.25. It makes no difference whether you take the pipe or not, the price is the same. While the supply of these pipes lasts they will be given away free to all who subscribe. Better get your order in early and be sure of a good smoke.

1911.

Weekly Free Press and Prairie Farmer. Winnipeg, Man.

Find enclosed \$1.25, for which send the "Weekly Free Press and Prairie Farmer" one year, and the "Canadian Thresherman and Farmer" one year, together with pipe, to the following address:

Name
Town
Province P.O. Box

You saw this advertisement in this magazine. Don't forget to say so when writing.

WESTERN CANADIAN IMPLEMENT DIRECTORY

EXPLANATION.—First find the Implement Wanted and the Number opposite will be the Number of the Concern, in the first column, that handles it.

1—AMERICAN SEEDING MACHINE CO., Winnipeg.
2—BEATTY BROS., Brandon.
3—BELL ROBT. ENGINE & TRUSHER CO., Winnipeg.
4—BRANDON PUMP & WIND MILL WORKS, Brandon.
5—BRITISH CANADIAN AGRICULTURAL TRACTORS, Saskatoon.
6—BUFFALO PITTS CO., Moose Jaw.
7—BURRIDGE-COOPER CO., Winnipeg.
7-1—Canadian Armstrong Quam Co., Saskatoon.
8—CANADIAN FAIRBANKS CO., Winnipeg, Calgary, Saskatoon, Vancouver.
9—CANADIAN HOLT CO., Calgary.
10—CANADIAN MOLINE PLOW CO., Winnipeg.
11—CANADIAN RUBBER CO., Winnipeg, Vancouver.
12—CANADIAN STOVER CO., Brandon.
13—CANADIAN SWENSONS CO., Winnipeg.
14—CASE, J. I. T. M. Co., Winnipeg, Regina, Calgary.
15—COCKSHUTT PLOW CO., Winnipeg, Regina, Calgary, Edmonton.
16—CRANE & ORWAY, Winnipeg.
17—DEREE, JNO. PLOW CO., Winnipeg, Regina, Calgary, Edmonton, Saskatoon, Lethbridge.
18—DE LAVAL SEPARATOR CO., Winnipeg.
19—DOMINION SPECIALTY CO., Winnipeg.
20—DUIS GEO. & CO., Winnipeg.
21—EMPIRE CREAM SEPARATOR CO., Winnipeg.
21-1/2—GARDEN CITY FEEDER CO., Regina.
22—GAS TRACTION CO., Winnipeg, Saskatoon, Calgary.
23—GENERAL SUPPLY CO., Winnipeg.
24—GOODYEAR TIRE & RUBBER CO., Winnipeg, Regina, Calgary.
24-1/2—GOULD, SHAPLEY & MUIR, Winnipeg, Regina.
25—GRAY-CAMPBELL CO., Winnipeg, Brandon, Moose Jaw, Calgary.
26—HAG BROS. & NELLERME CO., Winnipeg, Calgary, Regina.
27—HARMER IMPLEMENT CO., Winnipeg.
28—HART PARR CO., P. la Prairie, Regina, Calgary, Saskatoon.
29—HERO IMPLEMENT CO., Winnipeg.
30—HNT. HARVESTOR CO., Winnipeg, Regina, Calgary, Edmonton, Saskatoon, Brandon.
31—LISTER R. A. & CO., Winnipeg.
32—LOUDEM HARDWARE & SPECIALTY CO., Winnipeg.
33—MANITOWA WINDMILL AND PUMP CO., Brandon.
34—MASSEY-HARRIS CO., Winnipeg, Regina, Calgary, Edmonton, Saskatoon.
35—MAYTAG CO., Winnipeg.
36—McLAUGHLIN CARRIAGE CO., Winnipeg.
37—McRAE ALEX., Winnipeg.
38—MELOTTE CREAM SEPARATOR CO., Winnipeg.
39—MINNEAPOLIS STEEL AND MACH. CO., Regina.
40—MOODY MATHEW & SONS, Winnipeg.
41—NEEPAWA MFG CO., Neepawa, Regina, Winnipeg.
42—NICHOLS & SHEPARD CO., Regina, Winnipeg.
43—ARMSTRONG MANUFACTURING CO., Saskatoon.
44—PETRIE MFG. CO., Winnipeg, Regina, Calgary, Vancouver, Edmonton.
45—PIONEER TRACTOR CO., Calgary.
46—RAYMOND MFG. CO., Winnipeg.
47—REVES & CO., Regina.
48—RENFREW MACH. CO., Winnipeg.
49—RIEBSBURY PUMP CO., LTD., Brandon.
50—RUMELY M. CO., Winnipeg, Calgary, Saskatoon, Regina.
51—SAWYER & MASSEY CO., LTD., Winnipeg.
52—SHARPLES SEPARATOR CO., Winnipeg.
53—STEVENS BRUSH CUTTER CO., Didsbury.
54—STEWART SHEAF LOADER CO., Winnipeg.
55—TUDHOPE-ANDERSON CO., Winnipeg, Regina, Calgary.
56—TRENIDEN MFG. CO., Virden.
57—VULCAN IRON WORKS, Winnipeg.
58—WATERLOO MFG. CO., P. la Prairie, Regina.

60—WATSON JNO MFG. CO. Winnipeg.
61—WESTERN FOUNDRY CO., Saskatoon.
62—WESTERN STEEL & IRON CO., Winnipeg.
63—WHITE, GEO. & SONS, Brandon.
63-1/2—WINNIPEG CEILING & ROOFING CO., Winnipeg.
64—WINNIPEG RUBBER CO., Winnipeg.
BUGGIES AND CUTTERS.
Armstrong Buggies and Cutters. 15
Harris Buggies and Cutters. 16
Hayne Carriages Co. 37
Hoanville Buggies and Cutters. 17
Dominion Carriages (Transfer Agents). 6
Gray Buggies and Cutters. 25
Greer Buggies. 62
Honey Buggies. 10
McLaughlin Buggies and Cutters. 36
Munro-McIntosh Buggies & Cutters 10
Reinder Buggies. 17
Tudhope Buggies and Cutters. 35
CREAM SEPARATORS.
Blue Bell. 30
Champion. 35
Deere No. 2 Cultivator. 15
De Laval. 18
Empire. 21
Massey-Harris. 34
Melotte. 31
Munro. 46
Sharples. 15
Standard. 48
CULTIVATORS AND STUMP PULLERS.
Climax Stiff Tooth Cultivators. 15
Cockshutt Cultivator. 15
Deering Cultivator. 15
Deering Cultivator. 15
Elk (2 Horse) Cultivator. 17
Flury's Cultivator. 17
Rustler and Wood Scuffer. 17
Hilborn Stump Puller. 64
K. A. (2 Horse) Cultivator. 21
McCormick Cultivator. 30
Massey-Harris Corn Cultivator. 35
Paris Scuffer. 49
Sylvester Cultivator. 34
Verity Cultivator. 34
DISC AND DRAG HARROWS.
Ajax Drag. 17
Bissell Disc. 17
Boss Drag. 50-62-60
Canadian Moline Boss Drag. 10
Canon Disc. 32
Case, J. I. Disc and Drag. 27
Cyclone Wheel Disc. 17
Cockshutt Disc and Drag. 15
Cockshutt Lever and Clip. 15
Deer Disc and Drag. 17
Deere King Boss Drag. 17
Deere Steel Boss. 17
Deering Disc Harrow. 30
Deering Disc and Drag. 30
Economy Disc. 10
Emerson Disc and Drag. 64
Evans Disc. 35
Flury's Steel Chained Drag. 17
Flury's Clipped Drag. 17
Flury's Disc. 30
Fuller and Johnston. 61
Grand Detour Drag and Disc. 60
Hoosier Wheel Disc. 35
International Diamond and Lever. 30
Massey-Harris Disc and Drag. 34
McCormick Disc. 30
Moline Flexible Drag and Lever. 10
Noxon Disc and Drag. 64
Parson Disc and Drag. 49
Scottish Disc and Drag. 7
Superior Wheel Disc. 17
Universal Disc. 35
Universal Tongue Trucks for Disc Harrows. 17
Watson Drag. 60
Wilkinson Drag and Disc. 61
Windsor Disc. 15
FED AND ENSLAGE CUTTERS AND PULPERS.
Cockshutt Feed Cutters. 15
Cockshutt Pulper. 15
Flury's Feed Cutter. 15
Geiser Feed Cutter and Grinder. 7
Massey-Harris Feed Cutter. 34
Watson's Feed Cutter. 60
Watson's Root Pulper. 60
FEED GRINDERS.
Brandon. 6
Challenge. 60
Cyclone. 9 & 27
Diamond. 55
Flury's. 17
Gold Shapley & Muir. 15
Manitoba. 37
Maple Leaf. 44
Scientific. 60
Stover Ideal. 10
Stover. 10
Victor. 60
Watson's Ideal. 60

GARDEN IMPLEMENTS, INCUBATORS AND POULTRY SUPPLIES.
Chatham Incubator. 25
Cypress Incubator. 60
Fountain Spray. 53
Iron Age (Garden Implements). 53-61
Maxwell. 55
Planet Jr. Garden Tools. 41-55
CLEANERS, FANNING MILLS AND PICKERS.
Acme Pickler. 6
Automatic. 19
Chatham Fanning Mills. 25
Foster Fanning Mill. 17
Hero Fanning Mill. 29
Hero Pickler. 29
Superior Fanning Mills. 27
Webber Grain Cleaner. 10
Wonder Fanning Mill. 15
GASOLINE ENGINES.
Avery Tractor. 26
Brandon. 6
Buffalo Pitts (Tractor). 6
Case Tractor. 14
Fairbanks (Stationary, Portable Tractor). 14
Plain City (Tractor). 43
Fuller & Johnston. 61
Gas Tractor (18 & 30"). 22
Geiser (Stationary, Portable Tractor). 48
Gilsen. 7
Hart-Parr Tractor. 28
Holt Caterpillar. 24-1/2
International. 30
International (Tractor). 30
Ivel (Tractor). 30
Manitoba. 33
Minneapolis. 30
Master Tractor. 60
Nichols & Shepard (Tractor). 42
Ohio (Tractor). 58
"Oil Pull" (Tractor). 57
Massey-Harris Oids. 34
Pioneer (Tractor). 45
Rustler (Tractor). 35
Sawyer-Massey (Tractor). 51
Stickney. 43
Stover (Stationary, Portable Tractor). 12
Sylvester. 63
Twin City "40" (Tractor). 38
Universal (Gas Tractor). 50
Watrous. 68
Waterloo Boy. 7
HARVESTING MACHINES.
Champion. 30
Deering. 30
Frost & Wood. 15
Massey-Harris. 34
Massey-Harris Drag. 34
Massey-Harris Corn Harvester. 30
Noxon. 55
PAY LOADERS, HAY PRESSES, TRUCKS, TOOLS, MOWERS, RAKES, SWEEP RAKES, HAY STACKERS AND SHEAF LOADERS.
Admiral Hay Press. 15
B.T. 2
Burrill. 51
Canon Hay Press. 30
Champion Hay Rake. 30
Champion Mower. 25
Champion Side Delivery Rake. 34
Dain Hay Loader and Stacker. 17
Dain Hay Press. 17
Dain Side Delivery Rig. 17
Deere Hay Loader. 17
Deering Hay Stackler. 30
Deering Sweep & Hay Rake. 30
Deering Mower. 33
Frost & Wood Mower. 15
Fredder. 15
Frost and Wood Champion Hay Loader. 15
International Hay Stackler. 30
International Sweep Rake. 30
International Hay Press. 30
Jenkins Sweep Rake. 10
Keystone Hay Loader. 30
Louden Hay Tools. 32
Massey-Harris Mower Rake. 34
Massey-Harris Sweep Rake. 34
Massey-Harris Hay Tedder and Stacker. 34
Massey-Harris Side Delivery Rake. 34
McCormick Hay Stackler. 30
McCormick Mower. 30
McCormick Sweep & Hay Rake. 30
Noxon Mowers & Rake. 55
Stewart Sheaf Loader. 34
Success Hay Loader. 10
Tiger Steel Rake. 15
HORSE POWERS AND JACKS, SAW MILLS, WOOD SAWS AND TREAD POWERS.
Caters Wood Saws and Jacks. 4
Cockshutt Horse Power. 15
Flury's Horse Power and Jacks. 17
Flury's Wood Saws and Tread Powers. 17
Hoosier. 30
Keeney. 30
Massey-Harris. 30
McCormick. 30
Monitor. 10
Power Pressed Scrapers. 15
Sylvester. 55
Van Brunt. 17

LAND ROLLERS AND PULVERIZERS.
Acme Pulverizers. 17
Canon Land Roller. 30
Canon Packer. 30
Campbell Sub-Surface Packer. 30
Cockshutt Land Roller. 15
Cockshutt Pulverizer. 15
Cockshutt Combined Pulverizer and Sub-Soil Packers. 15
Deere Land Roller. 17
Flury's Pulverizer. 17
Fullerton Sub-Surface Packer. 10
Hilborn Land Roller. 55
Hilborn Pulverizer. 64
Moline Parallel Pulverizer. 10
Verity Land Roller. 34
Verity Pulverizer. 17
Watson's Flexible Pulverizer. 60
Watson's Land Roller. 60
Western. 61
MANURE SPREADERS AND LITTER CARRIERS.
B.T. 2
Clow and Co. 30
Corn King. 30
Hawkeye. 35
Kemp. 35
Mandi. 10
Louden. 32
Massey-Harris. 10
National. 10
Success. 17
GANG FLOWS, ETC.
Canon. 30
Case, J. I. 27
Case, J. I. Engine Gang. 27
Canon Moul Engine Gang. 30
Cockshutt. 15
Cockshutt Engine Gang. 30
Deere. 62
Emerson. 55
Emerson Engine Gang. 55
Geiser Engine Gang. 57
Grand Detour. 60
Janeway Engine. 1
Massey-Harris. 10
Moline. 10
Moline Engine Gang. 10
Noxon. 49
Ohio. 49
Railroad Grading & Root. Flows. 58
Verity. 34
PORTABLE GRAIN ELEVATORS.
Cyclone. 17
G-bush. 17
N.orth Star. 27
Tusgart. 63
Winnipeg Milling & Roofing Co. 63
Wizard. 27
POTATO AND BEET MACHINERY.
Aspinwall Potato Planters and Sprayers. 15
Aspinwall Sorters and Cutters. 15
Deere Potato Diggers and Beet Lifters. 15
Dowden Potato Harvester. 17
Egan Potato Sprayer. 43
Egan Potato Planter. 43
Eureka Potato Planter. 17
Hoover Potato Digger. 17
Hoover Knott Potato Digger. 17
Spittstoser Sprayer. 17
RIDING ATTACHMENTS, HARROW CARTS, WHEEL BARROWS AND HAND CARTS.
Cockshutt Wheel Barrow. 15
Cockshutt Harrow Cart. 15
L'neer Harrow Cart. 17
Eclipse High Harrow Cart. 27
Emerson Harrow Cart. 55
Flury's Wheel Barrow. 17
Fuller & Johnston Harrow Cart. 61
Kramer Rotary Harrow. 17
Naylor Harrow Attachment. 27
P. & O. Harrow Cart. 30
P. & O. Hand Cart. 30
Racine Rotary Harrow. 14
Superior Harrow Cart. 10
Verity Wheel Barrow. 34
Watson's Wheel Barrow. 60
ROAD SCRAPERS AND ROAD MACHINES.
Cockshutt Scrapers. 15
Good Roads Machinery. 59
Hoosier. 30
Russell Elevator. 32
Standard Reversible Grader. 17
Toron Pressed Scrapers. 15
Sawyer & Massey Reversible Grader. 51
SEEDING MACHINES.
Cockshutt. 15
Deering. 30
Frost & Wood. 15
Hoosier. 30
Keeney. 30
Massey-Harris. 30
McCormick. 30
Monitor. 10
Power Pressed Scrapers. 15
Sylvester. 55
Van Brunt. 17

THRESHING MACHINERY, SELF FEEDERS, WIND STACKERS AND ATTACHMENTS.
Advance. 50
American Always. 50
Aultman & Taylor. 30
Avery. 15
Bell Holt. 8
Case J. I. 14
Cuddy Steering Device. 62
Garden City Feeder. 211
Hawkeye Feeder. 35
Hartley Weigher. 58-67
Minneapolis. 30
Brown Wing Carrier (Ask any Thresher Co.) 41
Goodson. 35-68
Newpawa. 6
Nichols & Shepard. 42
Parson's Feeder. 35
Perfection Weigher (Ask any Thresher Co.) 41
Pickering Governor (Ask any Thresher Co.) 41
Reeves. 47
Ruth Feeder. 35
Sawyer Massey. 51
Godfrey. 24
Watrous. 59
Whitford Justice Measure. 26
White-Gee & Sons. 35
White Wings Feeder. 35
THRESHERS' SUPPLIES.
Brown Wing Carrier (Ask Any Thresher Co.) 41
Canadian Fairbanks. 8
Canadian Rubber. 11
Canadian Tire. 17
Desmond Stephen. 17
General Supply Co. 23
Godfrey. 24
Thresher Supplies Carried in Western Canada by all the Thresher Co. 41
Madison Kity Lubricators. 35
Mansel Oil Pumps. 17
Maytag Co. 35
Ohio Injection Co. (Ask any Thresher Co.) 41
Handled by all Leading Jobs and Thresher Companies. 64
WAGONS AND SLEIGHS.
Adams Farm Trucks. 15
Adams' Lories & Heavy Team (See also Co.) 15
Adams' Wagons & Sleighs. 15
Anderson Metal Wheel Trucks. 55
Avery Wagons & Sleighs. 28
Bain Wagons & Sleighs. 39
Canadian Crescent Wagon. 20
Chatham Wagon. 10-64
Cockshutt Metal Wheel Truck. 15
Columbus Wagon. 30
Davenport Wagon. 17
Electric Steel Wheel Truck. 27
Fish Bros. (Racine) Wagon. 55
Genuine T. G. Mandt Wagon. 10
Grand Detour. 30
Gray Light Farm Sleigh. 25
Hamilton Wagon. 30
Hamburg American Wagon. 64-60
Metal Wheel Truck. 17
Milburn Wagon. 30
New Deal Farm Truck. 17
New Moline Wagon. 17
Northern Sheet Metal Wheel Truck. 17
Old Dominion Wagons & Sleighs. 30
Petrolia Wagons & Sleighs. 28
Rushford Wagon. 39
Stone & gravel Spreading Wagon. 58
T. G. Mandt Sleighs. 10
Water Wagon. 30
Winona Wagon. 30
WELL DRILLING MACHINERY.
Austin. 6
Armstrong. 71
Brandon. 6
Sparta. 8
Standard. 48
WIND MILLS, TANKS AND PUMPS.
Caters Pumps. 4
Caters Star Windmill. 4
Canadian Air Motor. 43
Chicago Aeromotor. 27-7
Florence Pump. 44
Gold Shapley & Muir Wind Mill and Pumps. 24-1/2
Hayes Pumps. 35
Londen Pumps. 34
Manitoba Pumps & Wind Mill. 33
Manitoba Tanks. 33
Ontario Pumps. 43
Riesbury Pumps. 49

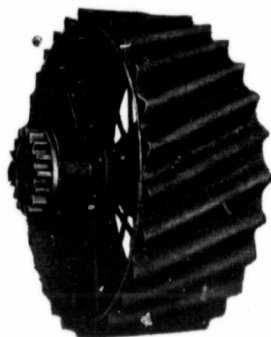

Tire Rolled Flat, 192" Long.

The illustration represents the tire and lugs of a Hart-Parr 60" drive wheel, rolled flat like a ribbon, with the lugs placed end to end. In this form the tire is 192" long and the lugs 252" long. The difference in favor of the lugs is 60", showing that they have 31% greater surface contact.

Lugs Rolled Flat, 252" Long.

BIG POWER FOR SPRING WORK

The size and quality of your 1913 harvest will depend, largely, on the start you give your crops this spring. The earlier the start, the better the crops. So this season, if you have a lot of spring plowing and seeding to do, don't depend on horses. Don't start with the odds against you and realize, too late, that your power supply is sadly over-taxed and inadequate. You need big, dependable power all year 'round, but you need it most in spring. You get it, too, if you own a

HART-PARR OIL TRACTOR

It furnishes you the combined power of 5 men and 15 to 30 horses. It will plow 25 to 30 acres a day, full plow depth. Work day and night and plow 50 to 60 acres daily. If it's sod to break or stubble to plow, with a Hart-Parr Oil Tractor you can jump right into your spring work as soon as the ground is fit to plow and stay with it until every furrow is turned and the last seed safely in its bed. The tractor does each operation in quick succession, without delay. Perfect plowing and a seed-bed, ideal for seed germination and growth, result. You finish weeks ahead of your neighbor who plows with horses. And this early start may mean the difference between profit and loss when your crops finally reach the elevator.

FIRST ON THE JOB IN SPRING

Unlike tractors with smooth tired drive wheels, fitted with wedge-shaped lugs, a Hart-Parr Tractor doesn't cut into the ground and dot it with a net work of small holes, with hard packed soil between. The drive wheels are equipped with wonderful wave formed lugs which afford 31% greater surface contact than any other form of lug. (See Illustration No. 2).

These lugs clean perfectly in soft ground and afford a bulldog grip without injuriously packing the soil. They do not chop up the ground but roll over it. Harrows, drills, discs, etc., cut the lug marks at right angles and thoroughly stir up the soil, leaving it in fine condition. These lugs really enable a Hart-Parr Tractor to work on ground so soft that it would force other tractors to stand idle for many days; in fact, you can put this "Modern Farm Horse" to work as soon as spring opens up.

This is only one of the many features that make Hart-Parr Oil Tractors the best tractor value on the market.

Farmers! Investigate This Best of All Tractors and Best of All Service

We want to send our brand new catalog and other literature to every Canadian farmer who ought to do tractor farming, but is still using horses. We want them to know why our tractors operate successfully on **cheapest kerosene**. We want them to learn of the advantages of our oil cooled engine. We want to show how our expert service **really serves**; how our quick delivery of repairs protects against serious delays and loss.

Write today for your share of this literature

Hart-Parr Company

30 Main St., Portage la Prairie, Man.

1616 8th Avenue, Regina, Sask.

57 West 23rd St., Saskatoon, Sask.

325 William Ave., Winnipeg

(Winnipeg Distributing House)

THE CHAPIN CO., 325 8th Ave. W., Calgary, Alta.

Agents for Alberta



You saw this advertisement in this magazine. Don't forget to say so when writing.

CASE

CASE

CASE

CASE

The PLOW that MEETS EVERY DEMAND

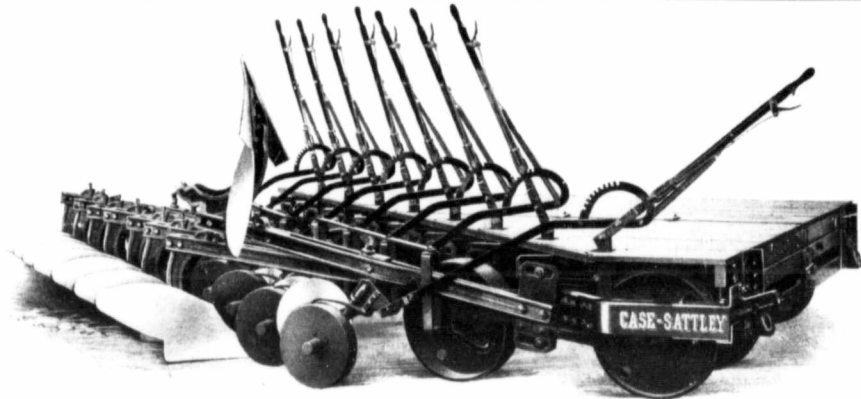

CASE-SATTLEY ENGINE GANG PLOWS

YOU couldn't ask more of an Engine Plow than the Case-Sattley Engine Gang-Plow will give you. Examine their Construction and you'll see that they are strongly and staunchly Built to with-stand Heavy Work and Hard Field Conditions. And yet—they pull wonderfully easy and are easily controlled. They insure Good Crops by plowing deep and with uniformity, putting the ground in the best condition for Seeding. Built in five sizes, 4, 6, 8, 10 and 12 Bottom, Stubble or Breaker. Can be used with steam or gasoline tractor.

Our Gang-Plow Catalog contains valuable Information of great interest to everyone interested in Power Plowing. WRITE FOR IT TODAY.

J. I. CASE THRESHING MACHINE CO.

INCORPORATED

741-791 STATE STREET, RACINE, WISCONSIN

CASE

CASE

CASE

CASE