

Genl. W. B. Bridges

FIELD SANITATION

BY

MAJOR

R. ST. J. MACDONALD, M.D.

Canadian Army Medical Corps



LONDON

OFFICIAL PUBLICATION

PUBLISHED BY THE JOINT COMMITTEE OF
HENRY FROWDE AND HODDER AND STOUGHTON
AT THE OXFORD PRESS WAREHOUSE
FALCON SQUARE, LONDON, E.C.

FIELD SANITATION

BY

MAJOR

R. ST. J. MACDONALD, M.D.

Canadian Army Medical Corps



LONDON

HENRY FROWDE

HODDER AND STOUGHTON

OXFORD UNIVERSITY PRESS

WARWICK SQUARE, E.C.

1918

Official Publication

66176600

UH600

M33

1918

PKX#

LONDON :

JOHN BALE, SONS AND DANIELSSON, LTD.,

88-91, GREAT TITCHFIELD STREET, OXFORD STREET, W.

00937435

PREFACE.

THIS book has arisen out of a series of Lectures by Major R. St. J. Macdonald, M.D., Sanitary Officer, Canadian Army Medical Corps, attached to the Third Canadian Division. The Lectures were given at the Divisional Sanitary School to officers, non-commissioned officers, and men engaged in sanitary work. The school was held in the Field as a matter of routine, and the various appliances, described and depicted, were on exhibit for purposes of illustration.

The Lectures are printed as they were spoken. They are the outcome of Major Macdonald's three years' service on the Western Front from Ypres to the Somme. They retain the flavour of the Field, and are reproduced in all the simplicity of the crude, but efficient, surroundings in which the School was held.

In the absence of books no literary references were possible, even if these had been desirable. With the illustrations, which were drawn by Corporal Sefton of the Sanitary Service, these Lectures give a faithful account of the measures which are in daily use—and with so great success—for the prevention of disease in the Army.

It is the intention that all medical officers shall be supplied with this book for their information and guidance in the discharge of their important duties. It may also be read with profit by officers in other Arms of the Service.

G. L. FOSTER, *Major-General,*
Director-General Medical Services,
Overseas Military Forces of Canada.

Sept. 1st, 1918.

CONTENTS.

	PAGE
1. PREVENTION OF DISEASE	1
2. WATER AND WATER SUPPLIES	13
3. AIR AND FOOD	32
4. DISPOSAL OF WASTE PRODUCTS	48
5. FLIES AND LICE	68
6. INFECTIOUS DISEASES AND DISINFECTION ...	91
7. DUTIES OF SANITARY PERSONNEL	111
8. SANITARY APPLIANCES—ILLUSTRATIONS AND DESCRIPTIONS	121

SYLLABUS.

FIRST LECTURE.

Prevention of Disease.

Preliminary remarks. Sanitary progress. Deaths from sickness and from wounds in past great wars. Causes of disease. Germs. Kinds of germs. Disease-producing germs. How germs get into the body. Proneness to disease. Immunity. How to prevent disease. Protective inoculation. Antityphoid inoculation. Results of antityphoid inoculation.

SECOND LECTURE.

Water and Water Supplies.

Sources of water. Impurities in water. Rain water. Surface water and underground waters. Pollution of waters. Diseases contracted from drinking water. Water purification. Boiling. Filtration. Chlorination. Chlorination of small quantities of water. Sodium bi-sulphate and chloride of lime tablets. Mineral waters. Water control. Drinking water at stand-pipes. Water for the front line. Water supply for an advance. Disinfection and cleaning of wells. Water-carts. Superstructure on carts. Chloride of lime. Lime juice in water-carts.

THIRD LECTURE.

Air and Food.

Ventilation. Impure air in barracks. Effects of impure air. Overcrowding. Ventilation in billets, barracks, tents, dug-outs. Cleanliness of food.

Diseases from food. Tape-worms. Dogs and diseases. Food poisonings. Tinned rations. Food contamination. Food contaminated by water, dust and mud, flies, infected persons. Safeguarding of food supplies. Food safes. Food at refilling points. Kitchens. Position of kitchens. Kitchen personnel.

FOURTH LECTURE.

Disposal of Waste Products.

Germs present in discharges from body. Disposal of excreta. Incineration. Burning. Types of incinerators. Latrines. Types of latrines. Fly-proof latrines for billets, camps, front line area. Pit and pail latrines. Selection of type of latrine. Disposal of urine. Soakage pits. Disposal of waste water. Sullage water from kitchens, ablution tables, baths, laundries. Disposal of dry refuse in camps, billets, shelled areas. Disposal of dead animals.

FIFTH LECTURE.

Flies and Lice.

Disease spread by flies. Life-history of flies. Kinds of flies. Development of flies. Prevention of fly breeding and killing of flies. Prevention of flies gaining access to infective material. Prevention of flies gaining access to food and cooking utensils. Treatment of horse manure. Incineration. Close packing. Giving manure to farmers. Manure in shelled area. Fly breeding in garbage. Killing of adult flies. Protection of food. Lice. Danger to individual. Disease spread by lice. Habits of lice. Dissemination of lice. Prevention of lousiness. Destruction of lice. Disinfestation by steam heat and dry heat. Cleanliness, ointment, powders, baths.

SIXTH LECTURE.

Infectious Diseases and Disinfection.

Infectious diseases. List of infectious diseases. Incubation period. Preventive measures. Notification. Removal of infected. Isolation of contacts. Disinfection. Venereal diseases. Incubation and quarantine period. Control of infectious diseases in civil population. Disinfection. Disinfectants. Antiseptics. Deodorants. Physical and chemical disinfectants. Disinfection by heat, boiling, steam, dry heat. Gaseous and liquid disinfectants. Sulphur. Formaldehyde. Chlorine. Clayton machine. Serbian barrel. Disinfection of a room, of clothing, of discharges from an infected person. Trench foot—causation and prevention.

SEVENTH LECTURE.

Duties of Sanitary Personnel.

Duties of sanitary personnel in front line area. In camps. In billets. In towns. Sanitary duties of Town Majors and Camp Commandants. Water duty personnel. Inspections of camps. Conditions found. Sanitary Standing Orders.

EIGHTH LECTURE.

Sanitary Appliances.

Improvised urinals. Latrines. Types of fly-proof latrines. Squatting latrines. Fly-proof covers for pails. Front line latrines Grease-traps. Improvised heaters for barracks, billets, and dug-outs. Food and meat safes. Refrigerator. Refuse containers. Ablution table. Improvised vapour bath. Treatment of waste water from ablution tables and bath-houses. Incinerators—types. Separation of urine. Measures for chlorinating small quantities of water. Arrangements at water-filling points. Chlorination of water at the pump. Water carriers.

FIELD SANITATION.

LECTURE I

IN beginning a series of lectures on the Prevention of Disease, I should like in the outset to ask you to give the closest attention. The importance of the subject of sanitation is sufficient reason for making this request, as I know how difficult it is to talk interestingly on a subject that at the best of times does not perhaps lend itself to very popular presentation.

In this war the infantryman is, of course, convinced that he is playing the great part; the gunner is equally certain that he is the chief factor; while the airman thinks that he, above all, as the eyes of the army, is most indispensable; and the hardy sailor, who goes down to the sea in ships, firmly believes that upon himself devolves the task of defeating the enemy.

And so it is that each unit in the Forces feels, and rightly feels, that through its efforts victory will come. That is the proper spirit, and is the spirit that sanitary personnel ought to have. That is the spirit that means victory, and it is when every branch of the Service is animated with this spirit that the most complete and perfect results are obtained. That is, above all, the spirit you should bring to this course, and I want you who are doing sanitary duties with battalions and other units to feel that you have the most important work to perform. It matters not how humble it may be; it matters not how uninteresting or unattractive it may be for others; for you it is the great opportunity. It is your contribution in this war. I want you to feel

that you have done, and are doing, a very great deal towards contributing to the splendid results obtained by the armies in the field. The more perfect the work done in the future the sooner will come the victorious end we are now approaching.

Some of you may wonder why you are troubled at this time with the prevention of disease, and may think this is a matter for medical men alone. This is a great mistake. It is, indeed, absolutely necessary to have the coöperation and the assistance of all ranks in order that the best results may be obtained. You all remember from your infantry or other training, "that the study of Sanitation and the Prevention of Disease is incumbent upon every officer and soldier." You may then ask the question, "Is it worth while?" "Have our efforts met with any, or what, success in the past?"

I am sure you all recognize the wonderful advances in preventive medicine. It is not so many years ago that small-pox was a very common disease, and you may have read that at one time it was so prevalent in this very country that few grown-up people were met, who did not show upon their faces its characteristic marks. Now, thanks to compulsory vaccination, the disease has practically disappeared.

Years ago the region of the Panama Canal was one of the danger spots of America on account of malaria and yellow fever. It has been stated that one of the chief reasons for the abandonment of the original canal scheme of De Lesseps, that distinguished French engineer, was the toll of human lives exacted. When, however, after the adoption of proper sanitary measures the work was finally completed by the American Government, these diseases almost ceased to exist, and to-day the canal zone is one of the healthiest spots in the world with an exceptionally low death-rate. The memory of many of you goes back to the day when the mere mention of the word "diphtheria" sent a shudder through every mother's heart, for she realized how faint was the hope for her stricken child. Now-

adays, thanks to medical progress, it conjures up no terrors. Prevention is the rule and cure almost a certainty.

There is a little island in the beautiful St. Lawrence in far-off Canada, where many crosses mark the graves of thousands of Irish immigrants, the victims of typhus or ship fever, about sixty years ago. This disease at the time was common and fatal. To-day it has well-nigh disappeared. Although some deaths are reported from the troops of the Central Empires on the Eastern Front, not a single case has occurred in the British Armies in France.

With regard to tuberculosis or consumption, the same improvement is noticed. Formerly jails and barracks and many public institutions were hotbeds of this disease, but in consequence of the greater attention paid to the laws of health, the mortality has been reduced one-half during the past forty years.

It is not perhaps generally known that in all the chief wars of the past more men have died from disease than from the weapons of the enemy, and it may be interesting as well as instructive to point out to you the part sickness has played in some of the great campaigns of other days. The most striking feature of all wars is the marked excess of the sickness admission rates over those of injuries received in action. Roughly, it has been estimated that for every soldier admitted to hospital for wounds, there were *twenty-five* admitted for some form of disease.

Many of you remember the South African War, a war which at that time was looked upon as one of considerable proportions and importance. Great Britain had engaged about 210,000 men, and of that number 6,965 were killed in action or died from wounds; 13,590 died from disease, and 72,551 were invalided. It was estimated that for every man admitted to hospital for wounds *seventeen* were admitted for disease.

In the Spanish-American War of 1898 ten times as many soldiers died from disease as from wounds

received in battle. At the beginning of last century, yellow fever carried off 50,000 of an army of 58,000 at San Domingo. The Bavarian Army of 28,000 in 1812 was so reduced in numbers after an epidemic of typhus that only 3,000 effectives were left. The same disease cost the Russians 60,000 out of 120,000 men after Plevna. The Turks for some time during the last Balkan War were losing 500 men a day from cholera.

In the war between Russia and Turkey in 1828 plague was responsible for the death of 6,000 men in one month, and from all causes the Russian Army of 100,000 suffered deaths to the huge number of 85,000. In the war of 1870-71 between Germany and France, there were 73,000 cases of typhoid fever with 6,900 deaths in the German Army.

It is no wonder that, in the face of such a record, every possible attempt was made to cut down the death-rate from sickness, and to the Japanese must be given the credit for first reducing the great disparity in the deaths from sickness and those from wounds. As a result of their efforts in preventive medicine in the war with Russia in 1904-5, the hitherto existing ratio was reversed, and twice as many men were killed in action or died from wounds as from disease.

You can readily understand how great at the outset of the present war was the concern felt by the directors of the Medical Services. Every effort was immediately put forth to prevent the spread of disease in the ranks of the soldiers. These methods met with most gratifying success, and the results shown in the Canadian Expeditionary Forces are most encouraging and illuminating. From the beginning of the war to December 31, 1917, there were: Killed in action, 22,919; died of wounds, 10,801; died of disease, 3,510. These are the figures of four fighting divisions in the field, and the results in the other British and Dominion divisions are equally satisfactory. These statistics show that nearly ten times as many men

have lost their lives from wounds received in battle as from sickness, and the reason is largely because of our increased knowledge of the causation of the disease.

THE CAUSES OF DISEASE.

From our point of view nearly all the diseases met with are caused by germs. There is, it is true, a class of diseases due to some disturbance of the function of the body caused by physical conditions such as trench foot and frost bite; but dealing with sound, healthy, physically fit young men, medically examined before they enlist, it is certain that nearly every single case of illness is due to germs.

Germs are exceedingly minute bodies belonging to the animal or vegetable kingdom. The most of them are so small that they must be greatly magnified before they can be seen. Their size may be anything from 1/5,000 to 1/10,000 part of an inch, and their shape may be equally variable.

If a germ or bacterium is shaped like a round dot, it is called a coccus; if it is like a rod or hyphen, it is known as a bacillus; if it is twisted or curved it is a spirochæte or spirillum. If a coccus is magnified 800 times it is as large as a period at the end of a sentence in a newspaper. A typhoid bacillus enlarged 800 times is the size of a hyphen between two words. All these various forms may be spoken of as germs, microbes, or bacteria. These are the names by which they are popularly known, whatever their shape or size.

Like all living things these germs reproduce and breed true; that is, each particular germ develops new ones like unto itself. Germs reproduce or multiply by dividing into two, and when conditions are favourable increase at an enormous rate; it has been calculated that one germ can produce 17,000,000 in twenty-four hours. They exist in myriad millions everywhere, in the air, in the ground, in water, though of course there are more in some places than

in others. You can realize there would be more in the air in cities than in the air on the top of a mountain or in the air above a body of water.

Although there are different kinds of germs, it must not be thought that they are all harmful; it is far from being the case. The vast majority are harmless and are capable of doing good, whilst often they are necessary to carry on the processes of Nature. Were it not for germs, certain kinds of cheese would not be so popular as they are; there would be no flavour to butter. The presence of germs in the stomach and digestive tract is necessary for proper digestion.

DISEASE-PRODUCING GERMS.

The number of disease-producing germs is fortunately very small.

What are the diseases produced by germs? The principal ones, as seen in the present campaign, are: typhoid, paratyphoid, dysentery, and diarrhœa.

Less frequently are: measles, scarlet fever, diphtheria, cerebrospinal meningitis, tetanus, mumps, and tuberculosis. And less frequently still are: plague, cholera, typhus, anthrax. Germs producing these diseases live, and thrive exceedingly well, when they gain access to the human body.

HOW GERMS ENTER THE BODY.—There are three principal ways in which germs enter the body:—

(1) Through the mouth and stomach by means of food and water; (2) through the nose, throat, and lungs by inhalation; (3) through a cut or wound of the skin.

Germs may enter the body in milk which has been infected on account of being handled by a person having a disease like scarlet fever, diphtheria, or typhoid fever. Milk may also convey a disease from which the cow may be suffering, especially tuberculosis. This latter is not at all uncommon, especially in children who drink a great deal of milk. Water may be contaminated by the human excreta soaking

or getting washed into it, and produce, for example, typhoid and cholera. Water, milk, and other foods may also become contaminated by flies which bring germs from latrines or from dust containing these germs. Typhoid, dysentery, and cholera are frequently spread by this means.

Germs enter the throat and lungs in the air that is breathed. The infection comes from dust as a rule. A person suffering from tuberculosis or consumption may expectorate in a room or on the street; the sputum dries up, gets into the air in dust, and is breathed by others. Diseases spread in this way are: pneumonia, influenza, tuberculosis, diphtheria, and small-pox.

Germs get into the body through cuts, scratches, or wounds. In this way the germ that causes tetanus is very dangerous. This particular germ is found in the soil, in the grass, or in fields that have been heavily manured, and for that reason it is quite evident why many more cases of this disease have occurred in the present war than in the South African War, where a great deal of the fighting took place in open wild country.

PRONENESS TO DISEASE.

It must not be thought, because disease germs are widely scattered and can get into the body of man in these various ways, that every time they do so disease will be set up. What happens when disease germs do enter the body is that they multiply in the blood and produce a certain poison, or, as it is called, a toxin. It is the distribution and circulation of this poison in the blood that makes a man ill.

There is a time between the entrance of the disease germs into the body and the setting up of disease which is known as the incubation or hatching period. This period may be a few days, as in scarlet fever, or several weeks as in typhoid, and is characterized by no symptoms; nothing can be observed except perhaps that the person is feeling unwell.

The reason why all persons do not contract the disease after the germs producing such have entered the body—why some do, and some do not, when equally exposed—is that there exists such a thing as immunity.

IMMUNITY.—We speak of a person as being immune to disease when he alone of several others equally exposed to the same infection *resists* disease. For example, all the men of a battalion may be drinking water infected with the germs of cholera and yet only half will get the disease. A platoon may be exposed to the infection of scarlet fever, and perhaps not more than five develop it. This power of resisting disease is called “natural immunity,” and is possessed by all, but by some to a greater extent than others; it may vary in the same person at different times and when exposed to different diseases. Man, for example, may be liable to Asiatic cholera, but is immune to hog or chicken cholera. Negroes very seldom develop malaria or yellow fever. It is believed the long sojourn of the race in the Tropics has given them an acquired immunity. Swine are not susceptible to glanders, though horses easily fall victims to the disease. It is very rare that dogs contract tuberculosis, but monkeys succumb quickly. This immunity or protection against disease varies considerably, and depends upon the health of the individual at the time of the exposure to infection. There is no question that excessive and long continued use of alcohol weakens the resisting powers and renders man very prone to disease. This is especially the case with pneumonia and tuberculosis. Immunity may be acquired by a previous attack of the disease. It is not often that an individual contracts an infectious disease more than once. The vaccination against small-pox and inoculation against typhoid give a form of acquired immunity.

This immunity is due to the fact that there exist in the blood of everyone certain substances which have the power of killing the germs that may get into it, or of neutralizing their toxins or poisons. If there is

a sufficient amount of this material in the blood, the onset of the disease will be resisted; if there is not, disease will develop. So long as a person keeps in good physical condition and leads a healthy, wholesome life, so long will his resistance to disease be at its best. It is quite possible for a person to carry the germs of pneumonia, influenza, and dysentery in the body without causing any symptoms, but if that person be exposed to great cold and wet, the resisting power may be overcome, and disease set up.

It is important to realize that a person may have completely recovered from a disease such as typhoid or dysentery, and still be a menace to the health of others; this occurs when he passes from his bowels or in the urine large numbers of bacilli. Such a person is called a "carrier." Many instances of disease spread in this way have occurred.

You have now been told how germs get access to the body, how by circulating in the blood they may cause disease, and how they come away from the body in the discharges from the bowels and in the urine, as in typhoid and dysentery; in expectoration, as in tuberculosis and pneumonia; and in the discharges from the skin, as in scarlet fever, measles, and small-pox.

HOW TO PREVENT DISEASE.

The next great subject to consider is how to prevent disease.

It is very obvious from what has been said that two things are necessary: (1) Keep up, or increase, the resisting powers of the body.

(2) Prevent, or lessen, the chance of disease germs entering the body. As already stated the resisting power of the individual is at its best when a clean, healthy, wholesome, regular life is led; and it is extraordinary what the human body can withstand, and resist, under these conditions. This natural resisting power can be increased by protective inoculation.

PROTECTIVE INOCULATION.—There are several diseases

in which protective inoculation gives excellent results, and it is hoped that as time goes on many more diseases may be added to the present number. The principal diseases in which we employ the protective inoculation are: small-pox, typhoid, diphtheria, cholera, tetanus, and plague.

The idea of inoculation or vaccination first suggested itself when it was noticed that a person having had one attack of an infectious disease seldom develops a second attack. It was thought that if a mild form of the disease could be given to an individual, it would prevent subsequent development of the disease.

It had been found that if the watery part of the blood of the person suffering from small-pox was injected into another, the second person would not develop the disease. This method, after the appearance of several cases of true small-pox, was discontinued and the present procedure adopted, namely, the passing of the germs of small-pox through the cow; in this method the cow is infected with the germs of small-pox from an actual case. The animal does not become ill, but develops sores, and from these sores or blisters is obtained a watery fluid, which when used as vaccine in a human being gives protection against small-pox.

The same result with similar phenomena is observed with regard to diphtheria. The germs of diphtheria when introduced into a horse cause the same appearance in the serum or blood of the animal of a soluble substance which counteracts the poisons of diphtheria, and this serum when injected into a man prevents the development of, and also acts as a curative agent against, diphtheria.

Let us take up the case of typhoid vaccination. It has been found that typhoid bacilli grow very readily on such substances as gelatin, and in ordinary broth or bouillon. The appearance is that of a white glistening growth with the gelatin and of a pale cloudiness in broth. The organisms are thus obtained and are killed by heating. It is this emulsion, then, consist-

ing of the dead typhoid bacilli, prepared with the most scrupulous care, that is injected into man when being inoculated against the disease. The effect is that the emulsion injected into the blood stimulates the tissues to produce an antibody which will counteract, or nullify, the effects of the poison or toxin produced by live typhoid bacilli when they gain entrance to the system in the process of eating or drinking.

EFFECTS OF ANTI-TYPHOID INOCULATION.—Is there any danger attendant upon this operation? Practically not the slightest. Before the men of the First Canadian Contingent, in number 33,000, left Canada, they received at Val Cartier anti-typhoid inoculation, and not a single individual was admitted to hospital as a direct result. The feeling that may occur is one of indisposition, lassitude, and weariness for a few hours; ninety-nine persons out of every hundred inoculated are able to carry on after forty-eight hours rest from duty. The protection thus given lasts for at least a year, and at the end of that time it is necessary to have it done again; in this the immunity conferred is not for such a long period as in the case of small-pox.

Has inoculation been a success? It has been one of the most striking successes of the whole war. It is also one of the greatest triumphs of modern medicine. It is a matter of pardonable pride for all medical officers to think that after a good deal of opposition it has finally been definitely established as one of the greatest boons ever conferred upon mankind. It may interest you to know that during the working out of experiments connected with the introduction of the serum, medical officers allowed themselves to be inoculated with three times the number of dead typhoid bacilli that are now given.

STATISTICS.—It is very easy to give a long array of figures to show the remarkable effect of anti-typhoid inoculation. In one of our own Canadian divisions for a period extending over six months during the spring and summer of 1916, there was not a single case of typhoid fever, and in the whole British Army

in France, an army running into nearly three millions, there have been comparatively few cases of this disease. In the South African War there were 57,000 cases with 8,000 deaths. One graveyard near Bloemfontein contains the bodies of 1,200 British soldiers, killed not by the bayonets of the Boer, not by the bullets of the sniper, but by the deadly bacilli of typhoid. Another very striking proof of the value of inoculation is shown in the figures taken from the United States Army records. During the Cuban War in 1898 a division of 20,000 men was under canvas at Chicamauga; with no inoculation during a period of ten months there were 1,729 cases of typhoid with 248 deaths. Three years later a division on the Mexican frontier, that had received inoculation, showed at the end of four months one case admitted to hospital and no deaths. Between the years of 1908 and 1913 there was not a single death from typhoid in the American Army, and in 1913 in an army of 90,000 men there were only three cases of typhoid.

OUTBREAK OF TYPHOID IN FLANDERS.

In the spring of 1915 a very extensive epidemic of typhoid occurred in Poperinghe, Vlamertinghe, Reninghelst, and surrounding districts. The people were unprotected and the mortality was very high. There were thousands of cases, and finally the Belgian Government took charge, and assisted by several British organizations got the epidemic under control at the end of three months. The first measure enforced by the Government was the passing of a law making inoculation compulsory. The people came promptly, and undoubtedly a great many were saved after receiving protective inoculation.

It is a remarkable fact that during that period, when disease was rife in the towns, when many of the wells were badly contaminated, and the bacilli of typhoid present in many homes and *estaminets*, practically no British soldier contracted the disease, although they

must have come into contact with the infection in a great many ways, as they were billeted throughout the whole area. The spread of disease can thus be prevented by protective inoculation as in the case of typhoid, paratyphoid, small-pox and diphtheria, cholera, plague, and tetanus.

Until such a time as scientists can provide protection against all infectious diseases, we must depend upon the second great means already mentioned for the prevention of disease, namely, to prevent, or lessen, the number of germs entering the body. How can this be accomplished? By the provision of good, clean water, clean food, clean air, clean camps and billets, proper disposal of excreta and dry refuse, disinfection, and control of the sick.

LECTURE II

Water and Water Supplies

The provision of an adequate supply of wholesome water is at all times a necessity. The quantity supplied is important for personal cleanliness, the quality is important on account of the danger of water-borne diseases.

SOURCES OF WATER SUPPLY.—All water comes from the clouds as rain or snow, and in falling on the ground may (1) evaporate and be lost; (2) flow down the sides of uplands and hills, and form rivers and brooks, lakes and ponds, according to the nature of the land or country; (3) sink into the ground if the soil is porous, and form springs or wells. These supplies are then referred to as rain water, surface water, and underground water.

IMPURITIES IN WATER.—Impurities may gain access

to water either at its source or during its distribution or storage. These impurities may be considered as being dissolved in water or in suspension. The impurities dissolved in water may be copper, lead, zinc, mercury, and arsenic. These poisons may be absorbed from the different metals used in making pipes, cisterns, or storage tanks, but arsenic or mercury may be deliberately added to the wells or springs by the enemy.

The suspended impurities are more important, and they may be either visible or invisible in water. The visible impurities are such materials as grit, mud, chalk, clay, or sand. These substances when taken into the body act as irritants to the delicate lining of the stomach, and cause inflammation which prepares the way for the germs that are always associated with such suspended matters. The invisible suspended impurities in water are germs and bacteria; these are the most important of all.

RAIN WATER.—Rain water, though not at all palatable, is the safest and purest of waters. In warm countries, where it is sometimes necessary to use it for drinking water, it must be properly caught and stored. Rain water is easily collected from the roofs of houses, barns, or other prepared surfaces. These surfaces, whatever they may be, as well as gutters, down pipes, or channels, must be kept free from pollution, such as excrement of birds, soot, decayed leaves, and refuse that might be blown upon the roof. The first washings should never be used, and when rain water is stored care should be taken that all receptacles are ventilated, well covered, and frequently cleaned to prevent pollution of the water. The best kind of tank is one of concrete, slate, or galvanized iron. Lead and copper are liable to give the poisons of these metals to the water, and wood after a short time begins to decay, and causes a disagreeable taste.

SURFACE WATER.—Surface waters are frequently used as a source of supply either from rivers or lakes. These waters are liable to pollution from:—

(1) Sewage of towns or cities running into them; (2) manure from cultivated lands along the banks; (3) latrines and urinals; (4) dead animals buried near banks; (5) swimming, or washing of clothes. Surface water running off hills uninhabited by man is much purer than that flowing over manured or well-cultivated lands thickly settled. There are cases where towns secure a good supply of drinking water from upland surfaces, but the gathering ground must be carefully watched so that no pollution gains access to the reservoir. Surface water should always be looked upon with suspicion and never used unless chlorinated.

UNDERGROUND WATERS.—Underground water from wells and springs is generally looked upon as being purer than surface waters, and there is a reason for the belief. As water trickles down through the different strata of earth it is filtered. The germs are caught in the upper layers, and therefore from a bacteriological point of view the water is pure. On the other hand, spring water or deep-well water may be hard on account of having absorbed mineral salts from the soil through which it passes.

POLLUTION OF UNDERGROUND WATER.—The chief causes of pollution of spring and well waters are:—

(1) Latrines, urinals, and middens in close proximity; (2) surface washings from houses or habitations getting access to water.

To give you an idea of the way in which water-borne diseases may develop, I shall ask you to picture a common village scene in this area. The well that supplies the drinking water is frequently placed near, often not more than a few feet from, the latrine. What occurs? A member of the family returns home after visiting a patient suffering from typhoid in a house where the necessary sanitary precautions were not taken; or the soldier returns after having "leave" in a town where the water supply contained the germs of typhoid. After the incubation or hatching period of from ten to fourteen days the individual becomes ill, and the excreta and urine are deposited in the

latrine or midden which is close to the well. The typhoid germs thus easily find their way into the water supply. This may be the means of spreading typhoid not only to the immediate members of the family, but also to all those who drink the water.

Again I should like to mention how water from a village may become polluted. Four miles distant from the village in question up in the hills, towards the source of the stream, is an isolated farmhouse. One of the household returns home suffering from typhoid. No preventive measures are taken, and the excreta is thrown on the ground outside the house. The ground slopes toward the river. Rains wash the excreta into the water supply, causing a small epidemic in the town ten miles away. That, as you know, is or rather was a very common method of getting an epidemic of typhoid fever in a village or town. You will not be surprised that typhoid fever develops in this way when I tell you that such a small quantity as one grain of excreta may contain twenty million germs, and a single drop of urine a thousand million germs. Typhoid bacilli may live for a week in soil and a month in water. This, then, is the way that typhoid is contracted from drinking water, and practically all that has been said about typhoid applies equally to paratyphoid or cholera.

Other diseases spread by impure water used for drinking are diarrhœa, parasitic diseases, lead, copper, mercury, and arsenic poisoning. Affections of the stomach may be caused by drinking hard water containing large quantities of iron, magnesium, and lime salts.

Having considered the sources of water supply and the ways in which contamination occurs it is now necessary to indicate the manner in which water may be purified and made fit for drinking. Before stating how water may be treated I shall say that all supplies must be purified before drinking, whether it be the soft water of the low-lying plains of Flanders or the hard chalk water of Artois and Picardy. In a thickly

populated country with an addition of millions of fighting men the danger of contamination of water supplies is very great, and it has been wisely decided that all water supplied to the Forces in the Field should be purified. How is it done?

WATER PURIFICATION.

There are three ways of purifying water:—

(1) Boiling; (2) filtration; (3) sterilization with bleaching powder.

BOILING.—This method is not applicable as a process on a large scale. It may be employed in small units when other means are not available. The water should be boiled for five minutes, in which time the germs that cause the ordinary water-borne diseases are killed. Boiled water is insipid; men will not drink it, and it is almost impossible to get water details to boil water day after day for long periods of time. The boiling of water was carried out with good results by the Japanese during the war with Russia, when large cauldrons were used and carried along with the advancing troops. In most cases the amount of fuel required for boiling large quantities of water is so great that it is impossible to obtain sufficient, and consequently other means must be adopted.

FILTRATION OF WATER.—By filtration of water is meant the system whereby water is passed through some material that removes the smallest particles of suspended matter, including germs. The materials most frequently used are: sand, gravel, canvas, flannel, sponge, asbestos, charcoal, candles of burnt clay or porous porcelain. Of these materials canvas, flannel, and felt are employed for purposes of clarification, that is, the removal of larger particles of sand, grit, and clay found in muddy and turbid waters. Filters of clay or pottery ware in the form of candles are very effective when dealing with moderately small quantities of water. The two best types are the Berkefeld and Pasteur-Chamberland.

These filters must be scraped and sterilized every three days by putting them in cold, clean water and bringing it to a boil for half an hour. The pores of these filter candles often get blocked by fine sand or clay, or germs may grow through them. Large filter candles have been fitted to water-carts, but in many cases were a failure, as the candles broke when the carts were driven over rough ground. These require a good deal of care, are fragile, and supply very small quantities of water. They are therefore only of service in small units, where they are carefully examined at frequent intervals.

SAND FILTRATION.—Filtration of water through sand is one of the most effective processes of water filtration. It gives good results in municipal life, but is not applicable in the field. The successful working of sand filtration depends upon the formation of a gelatinous layer composed of debris and dead bodies of bacteria. The surface of the filter bed is composed of sand and rubble, at least 12 in. of sand, and 3 ft. to 4 ft. of the other materials which act as a support to the sand. The sand must be clean and renewed frequently. The gelatinous layer which catches in its meshes the bacteria must be kept intact, and a part removed when it becomes too thick. Sand filtration on a large scale requires much time, care, and expert knowledge; it is rarely employed on active service.

An old and simple improvised method for filtration, or rather clarification, of water is to sink a barrel or box in a stream, placing a smaller barrel inside and filling up the inner space with clean sand. Holes are made in the bottom of the outer barrel and at the upper part of the inner one, thus ensuring clarification by means of sand. Another simple method of securing a certain amount of filtration or clarification applicable to river water consists in digging a pit 4 ft. to 5 ft. from the river and allowing the water to percolate through the soil before being used. In this arrangement when water is being drawn off care must be taken not to stir up the mud.

In addition to these there is another simple method of clarification with which all should be familiar. This consists in pouring the water through a blanket or sacking stretched over an improvised frame. The strained water is kept in a receptacle placed beneath. Sometimes it may be necessary to pass water through the strainer several times. A better result is obtained by adding some alum in the proportion of 5 gr. to a gallon, or a teaspoonful to a pail of water before it is poured through the strainer. The solution should be well stirred; the alum forms a gelatinous precipitate which entangles and immeshes most of the mud and suspended matters that are caught on the surface of the straining material. It must be remembered that alum does not sterilize the water but merely clears it, and should only be used for that purpose. Its action is slow, and it takes a couple of hours to do its work. The best results from the use of alum are seen when dealing with hard water containing lime, soft waters not being so readily cleared. Fortunately in the part of France and Flanders in which our lines have been cast we have very seldom had to resort to water clarification. I have now finished speaking of the boiling and filtration methods of purifying water, and may say at once that these methods are not practical, and are very seldom employed.

CHLORINATION OF WATER.—This brings us to the third and best method, namely, sterilization with bleaching powder, or the chlorination of water, as it is commonly called. This method is familiar to all, and consists in the addition of the proper proportion of chloride of lime to water, whether in water-carts, tanks, petrol tins, dixies, or water-bottles. I shall not give you any chemical reactions that take place, but will merely state that when the lime is added to the water it breaks up and gives off oxygen which kills or burns the germs that are in the water.

The amount of chloride added depends upon the quality of the water, and it is evident that as the oxygen given off will act on other impurities of an

organic or vegetable nature in water, as well as the bacteria, a greater quantity will have to be added to surface water after rains. In this case the washings have added a lot of vegetable matter, and as the oxygen given off from the lime will act on this as well as on the germs, it is necessary to add an extra amount.

Water details should take particular notice of what is said regarding the chlorination of water. The water-carts hold 110 gallons, and generally require one scoop of chloride of lime. Chloride of lime comes in one-quarter pound tins, and in each tin is found a measure that holds 2 grm. or 30 gr. of bleaching powder. When this quantity is added to the water-cart it gives approximately one part per million of free chlorine, the expression "free" or "available" chlorine meaning the amount of chlorine over and above that absorbed by the impurities present in the water. The number of scoops required can be easily ascertained by using the test case issued to all units. The chloride of lime is best used by adding some water and making a paste, which is then put into the cart. At the end of half an hour the water is sterilized. It has been found that if free chlorine is maintained in the water for half an hour the germs causing water-borne diseases will be killed.

There is a very simple way of showing the presence of free chlorine in water-carts. If you add a few drops of starch and iodide solutions, which are always in the test case, a blue colour at once appears if there is free chlorine present. When, however, the carts are being examined to see if the water details have been attending to the chlorination, the test should preferably be made three or four hours after the water has been chlorinated. If the test is not made until seven or eight hours after the chlorination it is possible that the chlorine has disappeared, and no reaction will be obtained.

CHLORINATION OF SMALL QUANTITIES OF WATER.—In many cases water-carts or large tanks are not avail-

able for supplying drinking water. In this event, arrangements must be made to chlorinate water in small quantities. The receptacles most commonly used are two-gallon petrol tins, rum jars, dixies, and water-bottles. Water details of battalions in the line or of small detachments must be familiar with the manner of chlorinating water for these small receptacles.

One of the methods adopted is to provide a strong solution of chloride of lime in a two-gallon petrol tin, and then add certain amounts of this strong solution to the water to be sterilized. If the water to be chlorinated is found to require one scoop of chloride of lime per water-cart, the procedure is as follows: One scoop of chloride of lime is added to a two-gallon petrol tin. The petrol tin is allowed to stand half an hour. Now, if a measure containing approximately 6 oz. of the strong solution is placed in a two-gallon petrol tin, the water receives the same amount of chlorination proportionately as the ordinary cart does when it requires one scoop per cart. A dixie containing three gallons would require 9 oz., and a water-bottle containing a quart of water would require almost an ounce.

A tin measure made from a jam or bean tin could very easily be marked to indicate three amounts, 6, 3, and 1 oz. respectively. These measures with a handle and a spout can be made by pioneers, or at the Divisional Supply Column, and one or two should be in possession of all water details. (See fig 57.) If the water is found to require two or three scoops of bleaching powder per water-cart, then two or three scoops respectively must be added to the two-gallon petrol tin in preparing the strong solution. The strong, or stock, solution must not be used after twenty-four hours; a fresh one should be prepared every day. The petrol tins or dixies may be tested for free chlorine half an hour after the stock solution has been added in order to ascertain whether it is of the correct strength. This is a simple and effective method of chlorinating water in small quantities.

WATER PURIFICATION BY SODIUM BISULPHATE.—There is another chemical method employed for sterilizing water, which consists in the use of tablets of sodium bisulphate. These tablets are obtained from the Senior Supply Officer of the Division, and are issued to medical officers for distribution. One tablet is sufficient to sterilize a water-bottle. The water should not be used for drinking until half an hour has elapsed. These tablets are only to be used in emergencies, as in the case of an advance before a regular supply of water can be obtained, or of small parties of men working in advanced places, or in the case of men being cut off from their units, and the only available water is that from the shell-holes and trenches. The bisulphate tablets may also be used by small units not in the possession of a water-cart, or by small working parties, or by any body of men where it is impossible to procure wholesome water. The men should be issued with a small bottle containing a number of these tablets. These tablets cannot be used with iron or copper water-bottles, as the action of the acid on the metal is liable to cause a development of poisons of these materials. In this respect the best type of water-bottle to use is one made of aluminium. These tablets are often made up with oil of lemon and sugar, and furnish a drink much like lemonade. The supply of tablets is generally limited, and therefore they should only be used in emergencies or under such conditions as those mentioned.

WATER PURIFICATION BY CHLORINATED LIME TABLETS.—Small tablets of chlorinated lime may also be effectually used for sterilizing water. They are conveniently put up in tabloid form, one of which is sufficient for two and a half gallons of water. The tablets should be folded in a sheet of smooth paper and powdered with the flat side of a knife. If mixed thoroughly with two and a half gallons of water the germs causing typhoid, cholera, and dysentery will be killed at the end of fifteen minutes. An objection to this method is that there is often a disagreeable taste

to the water. This taste can, however, be removed by adding a tablet of sodium sulphate to the two and a half gallons of water already sterilized. These tablets are put up in small bottles and issued with chlorinated lime. The tablets of chlorinated lime quickly take up water, and lose their strength if not kept carefully corked. They are not suitable for very warm climates. If the water to be treated either by bisulphate or chlorinated lime tablets is turbid or contains any matters in suspension, it should first be passed through a coarse strainer, as a piece of flannel or a jelly-bag.

Several other methods of purifying water are mentioned in books, but they are not practicable. The great method upon which we rely is that of chlorination, and you should never drink or allow anyone else to drink unchlorinated water. It makes no difference how good the water may appear to be, as taste and colour are no indication of purity. A sparkling, clear, beautiful-looking water may be badly polluted just as a water slightly brownish or greenish in colour, though not very inviting or palatable, may be safe for drinking. On no account drink water from wells used by civilians, even if positively assured by Madame that it is "très bonne pour les soldats." Do not think that because the civilians drink this water with apparently no bad results it is quite safe for you.

One of the reasons why not many cases of typhoid are seen in the civilian population is that some of these people have been drinking polluted water all their lives, many of them since their infancy. In that way the greater part of the population has become immune to these diseases. There have been several instances of typhoid occurring in families of civilians where the cause was polluted water and the bacilli of typhoid were found in the water. You may have passed through villages that have been put "out of bounds" for this reason. Another important point for you to remember is that anti-typhoid inoculation does not mean that you can drink with impunity water from

any source whatever. While inoculation does give excellent results and wonderful protection it does not guarantee that a person drinking continually from a well polluted with the germs of water-borne diseases will not contract these diseases. From what you have been told about immunity you can understand that by the continued use of contaminated water the toxins or poisons produced by the germs will eventually neutralize or counteract the protective substances received in the inoculation, and the disease will then develop. It is for the same reason that the inoculation must be repeated every year.

MINERAL WATERS.—I want to say a word or two about the drinking of mineral waters. Be very sure when you buy mineral or bottled waters that they are pure and fit for drinking. Do not think that because the water is bottled and has an attractive-looking label that it is a safe drinking water. Quite a number of these so-called mineral waters sold in local shops have been found on examination to contain water quite unfit for drinking.

There are, of course, a few standard waters like Perrier and Vichy that have always been found free from disease-producing germs and are quite safe, but on no account should other waters be taken until they have been examined and pronounced fit for drinking.

WATER CONTROL.—For the benefit of water details, I shall very briefly describe the method generally employed in Divisions for controlling water supplies. A certain number of authorized water points are selected by the O.C. the Sanitary Section in the area concerned. A list of these points is sent to the A.D.M.S. of the Division, who in turn sends the locations to the different units within his administrative area. The water at these points has been examined, and printed notices are affixed showing the amount of bleaching powder required per water-cart of 110 gallons. Every unit in the Division must send its water-carts to these authorized points, and in order to see that this is done it is customary to have a special chlorinating water detail posted at the different points.

These details keep a record of the carts, the unit, whether or not a water detail accompanies the cart, whether chlorination has been properly attended to, and the condition of the cart.

These reports are checked by the Sanitary Section and water patrol if there be such in the area. In this way it can be ascertained whether or not units are drawing their water supply from the properly authorized points. This system is in operation in the whole area occupied by the British Army in France and Belgium, and it is thus always possible for units either marching or at rest to obtain drinking water at these points. As the capacity of a water-cart is 110 gallons, two water-carts per battalion will supply 880 quarts, which is sufficient to fill the water-bottles of the whole battalion.

DRINKING WATER AT STAND PIPES.—When drinking water is available at stand pipes arrangements should always be made so that water-carts can be filled quickly and with a minimum of trouble. There should also invariably be tanks from which water-bottles, petrol tins, and dixies can be filled with chlorinated water. A light flexible hose-pipe is best adapted for this purpose, and a "stand" should be provided on which the hose-pipe can rest to prevent it from touching the ground when not in use. To ensure a continuous supply of chlorinated water two tanks are necessary, each one being used alternately. They should be fitted with small taps that can enter water-bottles and petrol tins; this prevents a waste of water. These tanks should be provided with dust-proof covers, and should be cleaned from time to time. (See fig. 59.)

WATER FOR THE FRONT LINE.

There should never be any difficulty about the supply of water for the battalions or any other Units in the rear. Sometimes it is difficult to provide drinking water for the trenches. The method generally adopted is that of filling the water-carts at the

authorized points behind the line and bringing them up at night as far forward as possible, often to Brigade Headquarters or other convenient points. Water-bottles may also be filled here, and a certain amount of water may be taken forward in petrol tins. These petrol tins are stored at Company Headquarters, where the men from the front line can come and fill their bottles.

In many cases water is pumped up as far forward as Battalion Headquarters, where it is available in tanks or at special points, and can be brought to the men in the front line by means of petrol tins. In these cases it is necessary that water details from battalions be on duty at the water point to see that the proper chlorination is being effected.

Where water is laid on by a system of pipe lines to the front area, a central chlorinating plant can be installed at the pump, thus ensuring a constant supply of chlorinated water at any point in the advanced area where water may be drawn. The objection to this method is that it might get water details out of the way of chlorinating water and lead them to suppose that all water from whatever source was chlorinated. The advantages, however, far outweigh this objection.

Another method frequently employed is that of sending a large number of petrol tins filled with water on trollies to convenient places in the support lines. Men from the different companies are sent back for full petrol tins, giving in exchange empty ones, which are brought back and refilled.

Very often it may be difficult, or impossible, to have water brought up to the front line by any of these means, and any available wells in the vicinity must be used. This sometimes happens when villages or areas have been lately captured from the enemy and the front lines pass through or near a village. In such cases it is not advisable to examine a great many of these wells and simply mark them as requiring one or two scoops of bleaching powder and expect that chlorination will be properly done. I have known an

instance where a water detail assured the Medical Officer that all water was being chlorinated for the different companies in the line, and when a complaint had been made about the taste of the water, it was found that the detail attempted to chlorinate all the water in the well by throwing in a goodly supply of "lime."

The most effective way to control the chlorination is to select two or three of the best wells per brigade and have the water details from the different battalions attend to the chlorination, relieving each other at frequent intervals. These details should be provided with a measure, as already described, for adding the proper amount of stock solution of bleaching powder to petrol tins. All other wells should be marked as unfit for drinking. As a rule the wells in the forward area are very badly polluted, and it is always advisable where possible to have water sent up the line from a reasonable distance behind, as it is much easier to control chlorination.

WATER SUPPLY IN CASE OF ADVANCE.

When an attack is planned with a fixed objective of a mile or more in depth every care must be taken to provide an adequate supply of drinking water. Each man going into the line in addition to his full water-bottle should be provided with a small bottle of sterilizing tablets that may be used in emergencies when no water is available except from shell holes or trenches.

Under Brigade arrangements a large number of two-gallon petrol tins filled with chlorinated water is placed in a dug-out or other protected place some time before zero hour. There are 1,600 petrol tins allotted to a Division for this purpose, and this number can be supplemented if necessary. This forms a reserve of water that can be taken further up the line by tram, pack mule, or hand carry. (See fig. 58.)

The Regimental Medical Officer should be provided

with two measuring tins, as already described, for the purpose of chlorinating water in small quantities in the event of wells in the captured territory being available. The Sanitary Section is responsible that samples of water in the wells taken over be examined for poisonous metals. Signs should always be ready to place on such wells, stating whether poisoned or fit for drinking with the number of scoops of chloride of lime required per cart.

If water is pumped up to the front line area, the pipes are extended very quickly by engineers, and the best method of chlorination is the introduction of chlorine at the source. (See fig. 60.) It should always be remembered that pipe lines may be cut and tanks destroyed by shell fire, and arrangements should be made for such contingencies. The best plan in such cases is an ample reserve of petrol tins.

DISINFECTION AND CLEANSING OF WELLS.

Sometimes it may be necessary, especially in the case of an advance, for wells in the area taken from the enemy or in our own front area to be cleaned out and made available for use. The first thing to do is to remove from the well all refuse that might have been thrown in it. A solution should then be made with half a barrel of freshly burned lime, and this should be poured into the well. The sides of the well should be scrubbed down as thoroughly as possible with the solution. At the end of a few hours the well should be pumped out, the same process repeated, and the well water allowed to stand for a day. At the end of that time the well is again pumped out and then allowed to refill. This process should be repeated until the water is perfectly free from lime.

If the burned lime is not available 1 per cent. solution of chlorinated lime may be substituted. In order that this solution may be made it is necessary to obtain the amount of water in the well. This can be done by making use of the following formula, which it is advisable to remember:—

$D^2 \times .7854 \times d \times 6.25 =$ gallons in well.

Where D = Diameter of well in feet.

Where d = the depth of water in well in feet.

The number of pounds of chlorinated lime required may also be calculated as:—

$$\frac{mD^2 \times d \times 23}{100}$$

The water should then be tested to determine the number of scoops of bleaching powder required. Any water that requires more than three scoops of bleaching powder is very grossly polluted, and should not be used for drinking purposes. Most of the springs and wells require one scoop in dry weather and perhaps two after rains. Frequent examination of the water is necessary to determine the exact amount.

In considering the advisability of using a well it is necessary to examine carefully the area surrounding the well. There is always a danger of the well being contaminated by the surface washings or the soakage from latrines, cesspools, manure heaps, or leaky drains. This particularly is the case where wells are situated at a lower level than any possible source of contamination, and therefore it is always advisable if possible to use a well that is situated on a high level. In this connexion it is necessary to remember that a well draws water from an area having a radius of four times its depth.

To prevent any surface washings from getting into a well, it should be lined on the inside with brick and cement to a depth of 12 ft. It should also be provided with a coping of brick or cement 1 ft. high. The well should always possess a properly fitting cover, the kind depending upon the method of raising the water. Scrupulous care should be taken to have the ground in the neighbourhood of the well free from refuse or debris.

WATER-CARTS.

One of the most important duties of the water personnel of battalions and other units is the keeping

of the water-cart in good condition. Water details are not supposed to do any other work except to chlorinate the water and look after the water-cart. There is, therefore, very little excuse for any water detail if his water-cart is not in good condition or not always filled with chlorinated water. The water tank in a cart should be carefully scrubbed out with the brush provided for that purpose by means of 1 per cent. solution of chlorinated lime at least every four days. If the lime is not available, boiling water can always be used. Petrol tins or any other receptacles used for storing water should also be cleaned frequently. On no account should potassium permanganate be used for the disinfecting of the interior of the tank.

Every effort should be made to keep the different articles in the box of the cart from getting lost or broken, and carts should be checked frequently to see that they are complete in every detail. If any of the taps start leaking or any of the fixtures get lost, the Quartermaster should at once be notified so that he may procure the proper repairs from Ordnance. On no account should articles of clothing, bread, or cheese be kept in the box of the cart. This box should be used only for the storage of the different parts of the cart and nothing else. Water-carts should never be used for supplying horses with water, or for carrying water to baths. If this practice is allowed it almost certainly means that the water will not always be chlorinated. The clarifying cylinders and cloths should be examined frequently, and the cloths should be washed often, and thoroughly dried to prevent them from rotting. The gauze carriers should also be cleaned, as otherwise they will become very dirty and get corroded.

CHLORIDE OF LIME TINS.—The greatest care should always be taken to examine the one-quarter pound tins of bleaching powder prior to use. If the powder on opening the tin shows any brown discoloration, or if there is any erosion of the tin, it should be discarded and a fresh tin obtained. The tins should be kept in

damp-proof boxes—small wooden boxes covered on the outside with tin and provided with a tin cover. These boxes should be large enough to hold two tins of bleaching powder and two tins of alum. If the unit is on the march an extra supply of these materials must be carried. A very good method to keep the lime fresh and dry is to place it in a wide-mouthed bottle with a tightly fitting cork and padded to prevent breakage. The little scoop in the one-quarter pound tins should also be kept dry and bright.

Water details must be careful always to add chloride of lime to the water in the body of the cart, and never put it in the metal gauze carriers of the clarifiers. The alum powder alone should be placed in these metal box carriers whenever it is necessary to clarify the water. In chlorinating water-carts or other receptacles the greatest care should always be taken that the proper amount of lime is added, as determined by frequent examinations. On no account should there be over-chlorination, as the taste of such water is disagreeable, as men will refuse to drink it, and, as a consequence, will probably have recourse to polluted water just because it tastes better. In these cases where a larger amount than one scoop is required a proportionately longer time should be allowed to pass before the water is used for drinking purposes. When chlorinating tanks and receptacles other than water-carts the exact capacity of these should also be ascertained.

SUPERSTRUCTURE ON WATER-CARTS.—An increased amount of water may be carried on a water-cart if a light wooden superstructure is arranged on it. This superstructure can carry about 35 petrol tins, which is often an advantage, especially when the Division is moving.

LIME JUICE IN WATER-CARTS.—Under no circumstances should lime juice be added to water-carts. The action of the lime juice on the galvanized iron is liable to produce zinc poisoning. An instance of this occurred not very long ago.

WATER REQUIREMENTS IN THE FIELD.—Each soldier requires daily the following amounts: in barracks, 20 gallons; in camps where no clothing is washed, 3 gallons; for drinking and cooking only, 1 gallon; for drinking as a minimum, 3 pints.

The daily requirements for animals are: horse, 10 gallons; mule or donkey, 6 gallons.

LECTURE III

Air and Food

The first subject upon which I wish to speak to you to-day is ventilation, the importance of which cannot be overstated. By ventilation is meant the removal of foul air in rooms, and replacing it by a supply of pure air. A constant supply of fresh air is as essential as a good supply of drinking water.

IMPURE AIR IN BARRACKS.—The air in barracks, billets, and tents is fouled by the breath of the occupants, by emanations or substances that come from the bodies and clothing, and by the products resulting from burning of fires and lights. The effects of breathing foul air are very marked, especially where there is any tendency to overcrowding. You have all experienced the feeling of lassitude and weariness so common when one gets up in the morning after sleeping in an overcrowded barrack room. It has been found that school children kept in a room improperly ventilated are duller and slower in working out problems than those occupying large airy rooms.

EFFECT OF IMPURE AIR.—The effects of continued breathing of impure air are: (1) The gradual weakening of the whole system; (2) debility; (3) loss of appetite and anæmia; (4) an increased predisposition to all kinds of sickness, especially bronchitis, pneu-

monia, tuberculosis or consumption, and cerebro-spinal fever.

It has occasionally happened that the air in small rooms occupied by a large number of men has become so poisonous that many of the inmates have suffered in consequence. This occurred several times in the history of the world when men have been shut up in dungeons or imprisoned in small rooms. You are all familiar since your schoolboy days with the story of the brave English civilians who perished during the Indian Mutiny in a small cellar known as the Black Hole of Calcutta. The air in deep wells and mines where no circulation takes place is often so impure that working men lose their lives when making a descent into them. It is not an uncommon thing to hear of street labourers losing their lives when entering a man-hole or going into a sewer. Death is due to poisoning by carbonic acid gas or another poison known as carbon monoxide. You must, therefore, remember that air may become very dangerous, even though it does not contain germs, although under Army conditions what mostly concerns us is the vitiation of the air by the germs of disease.

OVERCROWDING.—Overcrowding is the placing of a number of men in a smaller cubic space than has been found experimentally to furnish the required amount of fresh air. If one hundred men are placed in a barrack room built for forty men there is overcrowding. The amount of air that has been found necessary in ordinary circumstances is 3,000 cubic feet per head, per hour, and a cubic capacity of the room of 1,000 cubic feet. It is laid down in Army Regulations that each individual should have from 60 to 80 square feet of floor space and 600 to 1,000 cubic feet of air space, but it is very seldom on active service that more than 40 square feet or 400 cubic feet can be obtained. Another great danger resulting from the overcrowding of men in barracks and billets is the spread of infectious diseases. It is quite evident that if 100 men are living in one hut and a case of scarlet fever develops

the remaining 99 are also liable to contract the disease; but if 50 are living in the room, then only 49 will be exposed to infection.

METHODS OF VENTILATION.—Barracks are ventilated by: (1) Windows; (2) special ventilating openings; (3) stoves, braziers, and fireplaces. The more windows that exist the better the ventilation there is, and if possible windows should be placed on opposite sides of the room so that cross ventilation can be carried out. Simple arrangements can be made by windows to enable sufficient air to pass in and out of the room without causing draughts. Foul air on account of being warm rises to the top of the room and tends to accumulate there, hence the necessity of providing vents to allow it to escape.

If a sufficient amount of air is not provided by windows, special ventilators may be used. These are simple and are of various kinds, and are placed at a height of about six feet above the floor level. This height is employed in order to prevent draughts of cold air from striking upon the backs and heads of the occupants who may be living in the room. Open fireplaces act as good outlets, and when a fire is burning the utility of the ventilating shaft is greatly increased. Ventilation in huts and barracks can be arranged by having ventilating openings along the ridge of the roofs and under the eaves. Windows should be kept open day and night, weather permitting. The upper sashes of windows can be open at all times for three or four inches. One can always tell when entering a room from the outside by the smell or stuffiness whether or not proper ventilation is being effected.

BILLETS.—Billets are provided for troops when on the march from one area to another or when out on rest. In agricultural districts ten men can be billeted to each inhabitant, and five men to each inhabitant in towns and industrial centres. These numbers, however, are seldom adhered to, and it generally works out that as many men as can lie down in a room are assigned to it.

BARRACKS.—The ventilation of barracks is usually much better than that of billets in villages, as barracks have been built by Army authority. The very bad practice is sometimes seen in billets of double or treble bunking, in which two or three times as many men are placed as are compatible with good ventilation. These bunks are also very frequently placed so close to the wall that it is impossible to keep the rooms clean, and rubbish is often thrown under the lower bunks, where it accumulates and is difficult to remove. Where these conditions occur in the old French type of Baraque, hastily constructed huts with poor ventilation, it is necessary to make openings or ventilators at the bottom which will give access to fresh air and also enable the huts to be cleaned. The billeting of troops in barns, sheds, and outhouses, although very unsatisfactory and frequently very cold, is not as productive of disease as overcrowding of men in small rooms of houses in industrial districts. On account of a great number of cracks, holes, and other openings in the ordinary billet in agricultural communities, there is always an abundant supply of fresh air.

TENTS.—When tents are not overcrowded, they furnish the most healthful and convenient place for troops, and it has been noticed that the incidence of all diseases is much less when men are placed in tents than when they are in huts or billets. This was marked when Canadian soldiers were living on Salisbury Plain. Although conditions at that time were very trying on account of mud and rain, yet there were fewer cases of disease than when the men were moved into huts.

The bell tent is supposed to hold fifteen men, but it is seldom that more than eight men are placed in a single tent. Tents should always be opened up as much as possible during the day. The fly should always be rolled up and the door open so as to allow as much sun as possible to get into the interior. During the night the door should be left open; on no account should the small ventilating holes at the top

be stuffed up with paper or sacking in order to make the tent warm. If the ventilating openings in the tent are not kept properly opened there is just as much danger of having the air contaminated as in a close billet. If the tent has a floor, this floor should be removed at least once a month and the ground in the tent cleaned and ventilated. Tents are frequently set on a base of sandbags to make them warmer and more roomy. Where this is done care should be taken to arrange ventilating openings in the sandbags for the admission of fresh air.

DUG-OUTS.—The ventilation of dug-outs in the shelled area is important and difficult. In every case where it is at all possible, especially in deep dug-outs, there should be two entrances, thus allowing a continuous supply of fresh air to circulate through the dug-out. If it is impossible to make a second entrance it is not difficult to have a ventilating shaft constructed. The second shaft should always be directly opposite the door, and if there are others they should be in a line at right angles so that the prevailing winds may sweep through. This should be done on account of long periods of time that men must live in these places with very little opportunity of getting out into the fresh air.

Great care must be taken not to dry clothes over open braziers in dug-outs on account of the danger of men getting poisoned by the organic vapour driven off the clothes or from the carbon monoxide gas that comes from the burning charcoal. Whenever dug-outs, cellars, caves, or other closed shelters with no proper ventilation are occupied by men in winter, special care must be taken that no danger results from the use of braziers, burning coke or charcoal, or stoves without chimneys. Several men died a short time ago on account of these gases escaping from charcoal braziers in dug-outs and also in covered motor lorries. For the same reason the use of chloride of lime in large quantities to disinfect dug-outs should not be permitted as men have been gased through the chlorine that is

evolved. Damp or wet clothes should not be dried in barrack rooms, billets, or dug-outs, and provision for this should be made in separate drying sheds that are not to be used for living or sleeping rooms.

Dug-outs are often very damp on account of the percolation of moisture through the walls, roofs, and floors. The best way to avoid this is to have the ground over the top and around about the dug-out so levelled and drained that no water will collect on the ground surface within ten feet of the wall.

CLEAN BARRACKS.—Closely associated with ventilation is the cleanliness of barracks, huts, and billets. While it is most essential that pure air be introduced from outside, it is also necessary to keep the air inside rooms as clean and fresh as possible. This is done by taking all precautions to prevent dust and dirt from accumulating on floors, walls, shelves, boxes, and such places. A dirty barrack room is a great menace to health, as the germs of disease will remain alive for a long time in dust, and when the dust is disturbed or blown about it is sure to be inhaled into the lungs. It is, therefore, necessary to keep barrack rooms at all times scrupulously clean and free from dirt and dust. All chairs, tables, and benches should be scrubbed once a week with a solution of cresol, one and a half ounces to the gallon of water. The floors should be swept daily and scrubbed with water once a week.

Dusting should always be done with a damp cloth that has been washed from time to time in a disinfecting solution. On no account should water be sluiced indiscriminately over the floor or on the walls. Barrack rooms can never be properly cleansed in this way; some of the water escapes between the cracks of the floor or between the ceiling and flooring of upper stories, thus causing dampness. A considerable amount of water gets into the ground underneath the floor of the hut and a good deal is absorbed by the floor boards. The effect, therefore, is that too much water, dust, and refuse get under the floor, and if a fire is lighted in a barrack room in the evening, and

the windows closed, a sickening odour develops from the heated organic material, and perhaps there is decomposing material under the floor. This dampness and impure state of the air will lower the resisting power of the body and predispose to sore throat, rheumatism, and infectious disease.

Floors should not be covered with sand, as this causes dirt and dust to accumulate. Another practice that should always be avoided is that of putting blankets on recently washed floors, orderly rooms, or mess rooms to keep them clean. These blankets very quickly get full of dust, and mud, and filth from the boots, and in a very short time the air in the room becomes laden with germs of all kinds. On fine days blankets should always be placed out in the sun to be aired and freshened.

EATING IN BARRACK ROOMS.—One of the things most to be guarded against is the fouling of barracks by scraps of food and refuse after eating. It is, of course, impossible for you to have separate dining rooms. That makes it very necessary that all places where food is eaten should be kept clean and tidy. In these huts or billets where there are two or three rows of bunks it is very difficult to do this. If food must be kept in a hut or billet, it should always be put in a clean box and protected from flies. (See figs. 28-35.) Sandbags with simple lids that can be easily made should be hung on a nail outside the door of every tent, and the N.C.O. in charge should see that the men put scraps of food and refuse in this bag. (See fig. 36.) The contents of the sandbag, or whatever sort of receptacle is used, should be removed to the incinerator daily and burned. Another thing to remember is to keep huts and billets as free as possible from unnecessary boxes, packing cases, or chests. These materials simply invite dust, and it is extremely difficult to keep them clean on account of the tendency to throw refuse in or near them.

CLEAN FOOD.

It is not necessary to say a word about the quantity or kind of food received in the Army. It is worth noting, however, that never in the history of the world has an army been so well fed, so well clothed, or so well looked after as the British Army of the present day. There is an abundance of good, wholesome food, and a sufficient variety to give all the chemical constituents necessary for building up and repairing the tissues, and maintaining the energy of the body. It is indeed wonderful, and a matter for congratulation and a great tribute to the navy that, notwithstanding the submarine menace, and the general shortage of food the world over, there should be such uninterrupted flow of food to the armies in the Field. There does not seem to be a shortage in any single article of diet for the men at the front.

DISEASES CAUSED BY FOOD.—There are certain diseases that animals furnishing food may develop, which may be communicated to man by eating the food. For example, tuberculosis of the udder of the cow, where the germs of tuberculosis get into the milk, may give rise to tuberculosis of the bowels. The same disease may be caused by eating the meat of the cow so affected. It has been stated, though not definitely proved, that cows may develop diseases very similar to scarlet fever and diphtheria, and that these diseases may be communicated to man. The commonest affection caused by eating diseased meat is that due to tape-worms. There are two different varieties of tape-worms generally met in civil life, one found in the meat of the cow, and the other in the meat of the pig.

TAPE-WORMS.—There is a connexion between the conveyance of these affections and dogs. A dog may eat the flesh of a pig with tape-worms, and develop the disease to the extent of passing from the bowels the eggs or ova of the worms. These eggs may get into milk or water and be taken into the body of man

with the result that tape-worms are produced. You have often heard of, and many of you are likely familiar with the condition known as "measly meat," which is the name applied to meat so affected. You must remember, however, there is very little danger of contracting any of these diseases, as the germs of tuberculosis or consumption, and worms in meat are all killed if the meat is properly cooked and the milk boiled.

For the reason just given in civilian life dogs are never permitted around abattoirs or meat shops, neither should they be tolerated in the vicinity of messes, kitchens, or cookhouses in the Field. The somewhat common practice on the part of officers, non-commissioned officers, and men of keeping dogs should not be encouraged. And as rabies, a disease also associated with dogs, is common in the whole area occupied by the British Army in the Field, there is further ground for keeping the number of dogs down to a minimum, or at least muzzled and kept under supervision. I might add in passing that a not inconsiderable amount of food is consumed by dogs. All meat furnished the armies in the Field is carefully inspected and stamped before shipment, and as it is brought up the line in refrigerator cars and well cooked before eating, there is never any question as to its wholesomeness.

FOOD POISONING.—There is much more danger from food poisoning, or as it is generally called ptomaine poisoning. By these terms is meant a group of diseases caused by living germs in the meat, or by toxins, or poisons formed by these germs. This form of poisoning generally occurs with the flesh of pigs in various forms, but fish and tinned meats may also be the cause. In civil life bear meat has frequently caused death from ptomaine or food poisoning. A sure means of prevention is to see that food comes from an authorized source. The quality of meat shipped is nearly always good, but cooks, if at all suspicious, should take a piece of meat, and open

with a knife; and if there is an odour of putrefaction the meat should be discarded. This frequently occurs with no evidence on the surface, the meat looking clean and healthy.

TINNED RATIONS.—A large quantity of food comes as tinned rations, and it is necessary to say a few words about examination of the tins. The tin should always be concave at the ends, and should give a dull sound on tapping. If the contents go bad there are gases formed by putrefaction, and the ends of the tins will be bulged out, or "blown." Such tins should be discarded. If there are more than two holes in the tin your suspicions should be aroused. On account of the way the contents are put into tins, it is necessary to have one or two holes, but never three. If there are three it means that the tin went bad, putrefaction set in, and a hole was made to allow the gas to escape and prevent the tin from being "blown." This third hole should be looked for near the rim.

Tins should always be painted with date of filling, and labelled, as a fresh-looking label does not necessarily mean fresh contents. The rim of the tin should not show any projections of solder from the seams or holes. Solder consists of lead, tin, or zinc, all poisonous metals. If there is much solder present it may, on account of its solubility, get into solution and cause poisoning. During the early days of the war the soldering of tinned food and all mess tins and dixies was very poorly done. Large amounts of solder were allowed to remain along the joints, and on examination it was found that certain foods cooked in dixies could absorb enough lead to cause poisoning. This carelessness in manufacturing these articles has been checked and practically no danger now exists.

The contents of all tinned rations should be carefully examined, and if there is heavy blackening of the interior of the tin, the tin should be at once discarded, as it means decomposition has taken place. The blackening is due to a deposit of sulphide of iron, resulting from the chemical action of the products of

decomposition on the solder and tin. The examination of tins of meat rations is very important and very necessary. Sometimes tins of meat ration have been salvaged from dug-outs or billets, where they have been for long periods of time. And it is particularly necessary that these should be carefully looked at for any evidence of "blowing," or whether there are any signs of their being eaten through with rust, or in any way damaged. If there is the slightest doubt about the purity of the contents they should at once be discarded. While cooking is a protection against the forms of food poisoning caused by living germs, and only then when the temperature is high enough to reach the interior, it will not destroy poisons already formed in meat, or obviously germs that might have gained entrance after cooking.

FOOD CONTAMINATION.—You must allow me once more to mention the principal diseases caused by contamination of food: typhoid, paratyphoid, dysentery, diphtheria. Foods are contaminated by flies, dust, infected persons, and water. To appreciate how this is done, let me give you a few examples:—

FOOD CONTAMINATED BY WATER.—Milk may be rendered dangerous for use if it is diluted with water that contains germs of typhoid. Milk may be contaminated, though not watered, if the pail containing it is cleaned out with water laden with disease germs, even though only two or three drops remained in the bottom. Again, if the milk is left uncovered it may be contaminated by dust blowing into it from rooms in which it is stored.

If in a camp there is an open trench being used as a latrine, and there is a typhoid case, or a typhoid carrier uses this latrine; and, as frequently happens in such cases, the excreta and urine are deposited on the sides of the trench, then the germs of the disease get on the earth, or the sides of the trench, and from there on the boots of men. This mud is brought into the billets or dug-outs, and is deposited on the floor, where it dries and gets into the air as dust, and if

there is any milk or food not protected, it gets into the stomach of men and causes disease. The dust from latrines, urinals, or other infected places may be blown directly into buildings through open doors and windows, and thus pollute the food-stuffs.

Another way in which food may be contaminated by dust occurs as a result of the pernicious practice of cleansing cooking utensils with sand or mud, taken very frequently from near latrines, perhaps from the path or walk leading directly to the latrines.

To prevent this sand should first be burned to kill any germs, or wood ashes may be employed. These materials should always be kept in a box especially for the purpose. Although germs causing disease in this way may live in dust or mud for four or five days only, you must not think there is very little danger. As a matter of fact the danger is very great, when you remember the enormous number of germs that may be in the smallest grain of excreta or drop of urine. The grounds of camps are very frequently infected by burying the contents of latrine buckets not deeply enough, and with too little covering in close proximity to kitchens. Hence the great necessity of never having kitchens or dining rooms placed near foul ground.

FOOD CONTAMINATED BY FLIES.—Food is very frequently contaminated by flies, and one of the greatest problems in the field of sanitation is that dealing with the fly question. The measures taken against the production and development of flies will be dealt with later. At present I merely wish to point out that flies invariably are found in the trench where excreta or other refuse is buried. The flies get the germs of disease on their legs or bodies, and then may go direct to some bread, jam, or milk, and thus contaminate them. A great number of infectious diseases are caused in this way.

FOOD CONTAMINATED BY INFECTED PERSONS.—I am here repeating what has been told you already. A person suffering from typhoid, or a typhoid carrier, employed in cookhouses or otherwise in the handling

of food very often is the means of spreading disease. Milk is perhaps most frequently contaminated in this way from the hand of the person employed in dairies or in connexion with food distribution. Many cholera epidemics have been caused by infected milk. I may point out that milk is a great breeding-place for germs; much better than water, or almost any other food-stuffs. There are many instances mentioned in medical books showing the number of cases of disease spread by carriers. The following examples illustrate how this has occurred. A cook who turned out to be a carrier on one occasion made some pies which caused 110 cases of paratyphoid and six deaths. Another cook, a carrier, at intervals was responsible for 28 cases and two deaths.

TREATMENT OF CARRIERS.—The only way to prevent the spread of disease is to see that no person who is a carrier of any disease should be employed in handling or distribution of food. All men doing duty around kitchens should have their excreta examined, if any suspicion exists. In some battalions when a case of typhoid or dysentery occurs, all the remaining men are made to undergo examination. This entails a great deal of work, but it is the only way to be sure of preventing the spread of disease in that manner. Other diseases besides typhoid and paratyphoid liable to be contracted in this way are cholera, dysentery, diphtheria, and cerebrospinal meningitis.

A great deal of care should be exercised in the food eaten. Milk bought from civilians should not be taken unless previously boiled for a few minutes. In some parts of the country farmers or others are not permitted to sell unboiled milk to soldiers. There is perhaps more trouble with unboiled milk in officers' messes than anywhere else. Fortunately condensed milk is supplied in tins, and there is not the necessity for buying fresh milk. Unwashed vegetables should always be looked upon with suspicion, and when fruit or lettuce or vegetables are bought from civilians, the greatest care should be taken to see that they are well

washed with chlorinated water before consumption. There is always a danger of contracting typhoid from shell fish, oysters, or mussels grown in sewage-polluted water; in many camps the consumption of these articles is forbidden.

SAFEGUARDING OF FOOD SUPPLIES.—Having spoken of the ways food might be contaminated, I wish now to take up the protection of food. Food should always be protected from flies at all times, before, during, and after preparation. This brings us to the question of kitchens and cookhouses. To prevent the fouling of food, it is advisable when possible to have large dining rooms. This can be done at the base and with certain units well behind the lines, but it is out of the question with most of the fighting units. With these food must be taken in tents, barracks, billets, or dug-outs, as it is impossible to have common dining rooms.

FOOD SAFES.—It is necessary to have several receptacles, so that if food is kept for any length of time it cannot be contaminated by dirt or flies. It is very easy to improvise food safes. An ordinary 50 lb. biscuit box can be provided with a cover of canvas having a weight at the end. The tin boxes that biscuits come in may also be utilized. Large tin ammunition cases are useful, and on account of their size are most convenient. You will be able to see different types at the sanitary exhibit arranged for this school. (See figs. 28-35.) There are certain articles of food that attract flies to a greater extent than others, namely, jam, beef, butter, beans, cheese, sugar; these must be especially protected at all times. Meat, on account of being cooked before eating, is not as important in this respect. In every kitchen there should be plenty of dishes for washing the hands, also separate towels, and always a quantity of cresol, $3\frac{1}{2}$ oz. per gallon, for disinfecting purposes. It is often possible in officers' and other messes behind the line to provide wire gauze for all windows and doors of kitchens and cookhouses. There should really not be the slightest difficulty in securing the protection of all

food-stuffs, as enough boxes and tins can always be obtained by every unit for this purpose.

FOOD AT REFILLING POINTS.—In considering the protection of food supplies, I shall especially call your attention to the necessity of having food protected at refilling points. Too often there is not the slightest effort made in this direction. Food-stuffs are left on the ground near dumps or in wagons, lorries, or barges uncovered and unprotected. The result is that there is contamination from the germs in the mud, dirt, and dust. Representations should frequently be made so that all refilling points are provided with clean fly-proof and dust-proof storage sheds. The greatest care should also be taken to see that food on transport wagons is covered as a protection against dust and dirt.

KITCHENS.—As the question of the protection of food is closely associated with kitchens, I shall speak about kitchens and cookhouses. In the first place, kitchens should be situated as far as possible from latrines, at least 100 yards. This can be done when camping in the open, but it is manifestly impossible in many billets in towns.

The next thing to consider is the personnel in kitchens. All those cooking and handling food should be scrupulously clean at all times. It is well to have certain men detailed permanently to handle food. If that is so, much better results can be obtained. Men should not be sent to cookhouses and kitchens to do fatigue duty because they are not fitted for their work with battalions. With this practice it is impossible to keep things clean. Cooks and helpers should be healthy and of clean habits. No person who has had typhoid, paratyphoid or dysentery should be permitted to work in kitchens. Any of the helpers in a cookhouse or kitchen developing diarrhœa should be at once relieved. Cooks and their assistants should be watched for any infectious diseases; and it is certainly the duty of sanitary personnel to report any cases of rashes occurring on workers in kitchens.

Cooks and their assistants should be clean persons and wear clean clothing. Special canvas suits can always be drawn for cooks. These are washable and should be washed at frequent intervals. On no account should cooks or their assistants sleep in the kitchen, shave in them, or keep any articles of clothing or equipment there. There is a strict Army order which especially states that under no circumstances should any one sleep in a cookhouse. It is one of the most difficult things to prevent, and a variety of reasons is given, the chief being that it is necessary to see that no food-stuffs are stolen.

The cookhouse should be thoroughly cleaned out daily and whitewashed every month. Cookhouses should be sprayed weekly with a solution of formalin, 2 oz. to a gallon, and two or three times weekly during the fly season. All windows and shelves should be washed down daily. Chopping blocks should be regularly scoured, a wire brush being used for the purpose. No dirty rags or cloths should be allowed to be kept in any cupboard, or drawers, or in kitchens, and a sufficiency of clean cloths should be available. All cans, dishes, plates, knives and forks should be carefully cleaned with sterilized sand or wood ashes, or fresh quarried chalk, after a meal has been finished. It is essential that fly-proof boxes be provided for utensils, such as plates, knives, forks, cups, and saucers. If this is not done flies may get access and foul them with their excreta.

It is hardly necessary to say that cooks and their assistants should not have anything to do with the care and cleansing of urinals and latrines. This precaution is essential with regard to food that requires no further cooking. It is not imposing a great hardship on cooks or their assistants to ask them to keep their kitchens clean and tidy, and it is remarkable that in many cases battalion cookhouses up the line are kept in a much more cleanly and sanitary state than those in billet towns.

It is imperative that all precautions should be taken

to prevent rats from getting access to food in the trenches, and one of the best safes to use is a biscuit or petrol tin with tin cover set in the wall of a dug-out. If wooden boxes or tables are used it will be necessary to cover them with strong wire or expanded metal, as otherwise rats will get access to the food.

There is a special danger of contracting a disease known as acute hæmorrhagic jaundice, a fatal disease, on account of rats urinating on food, and infecting it with germs of the disease. If any of you notice an appearance of sickness among rats, or rats that have died apparently from poisoning, you should at once report it to your medical officer.

LECTURE IV

Disposal of Waste Products

You will remember that, in speaking to you a few days ago about the causation of disease, I said we worked along two lines, first, in maintaining the resisting power of the individual at its highest; and secondly, in preventing, or lessening the liability of, disease germs gaining entrance to the body.

I have already told you how the resisting power is kept up locally by protective inoculation. I have also told you that we lessen the possibilities of disease germs gaining access to the body by ensuring clear air, clean food, clean billets, and barracks, with a proper disposal of waste products. It is of the disposal of waste products I propose to speak to-day.

The germs of disease, as you know, are found in the waste products, the discharges from the body, and in the bodies themselves of men and animals. It is consequently necessary to dispose of these waste

products in such a way that there can be no danger of the germs getting back into the body again and thus causing disease.

DISPOSAL OF EXCRETA.—The proper disposal of excreta is of the greatest importance, and every effort should be made at all times to see that human excreta is so disposed of as not to be a menace to health. In what way is there danger? Why are we so insistent that special care should be given? The great danger is either on account of the liability to contaminate water supplies, or the accessibility of flies to faecal material. If the first occurs, epidemics of water-borne diseases, such as typhoid and cholera, may take place. If the second occurs, there is the danger of flies directly conveying the germs of disease from the excreta to the food.

It has already been pointed out the manner in which germs may get from a latrine to a water supply like a river or well, and also how flies alternating between latrines and kitchens may spread disease. How, then, should excreta be disposed of? There are two ways:—(1) Incineration or burning; (2) burying.

Incineration is much the better, and should always be carried out when possible. If all faecal material is burned, then of course the germs are killed and there is no danger. It is therefore the quickest and most effective way of disposing of infected material. This can easily be done in incinerators, and is the method employed in many large barracks, where it gives complete satisfaction. It is not applicable in the field to any extent except at rest stations and permanent camps well behind the line, but it is eminently suitable for units at the base and on the lines of communication.

There is sometimes an objection raised on account of the odours produced in the incineration, an objection that should never be considered, as often the odours are purely imaginary, and most incinerators are so constructed as to burn up all the gases produced. A more serious objection is that they often require fuel

that is difficult to obtain. Except in the case of a few units there is not enough dry refuse available from the ordinary camps to burn the excreta. This difficulty can sometimes be avoided by obtaining sawdust from the engineers' dumps or buying it at French saw mills, where it can be purchased for a few centimes a load. Dry horse manure in the summer may also be used.

Incinerators should always be covered over. They should be placed as far as possible from living rooms and kitchens, although there is little objection to having them within 50 yards, and often in small camps it may be necessary to have them much closer.

If there is enough sawdust available, it can be used to soak up the urine and then burned. If not, it is desirable to have close to the incinerator a soakage pit into which urine from the latrine pails may be emptied. Sometimes a base may be arranged where the solids can be mixed with dry refuse or sawdust before being put into the incinerator. (See fig. 48.) This base as well as the floor of the incinerator should be of concrete when possible. There should also be a shed or shelter provided to store the refuse and fuel, and keep it dry.

The success in the operation of the incinerator depends upon having as great a depth of fire as can be obtained with the maximum of heat. The great heat generated can be used for baths and ablution tables; and many ingenious devices have been arranged to this end. In some incinerators a drying shelf is put in to make the burning up of the solids easier. (See fig. 48.)

You will see the different types of incinerators at the exhibit, except, of course, the cast-iron and more elaborate ones that are used behind the lines. Of the latter the Horsfall is probably known to most of you and gives good results. In this type the fire brick needs to be renewed every few months; the iron sides and door frequently crack on account of the great heat produced, hence it is necessary to support them with iron straps.

Another type of incinerator for burning excreta is one made of brick of the usual pattern with a closed chamber, a dry slab, and a chimney. They are somewhat expensive, as bricks are not always available, and there is the difficulty of getting transport to haul the bricks. They require skilled men to build them, and need to be renewed every few months.

The type made from biscuit tins or four-gallon petrol tins filled with clay and wired together with a grate of iron bars, a drying shelf, and a flue of cresol drums gives equally good results. (See fig. 48.) It has the advantage that it can be made any time from material always available in the field. It usually lasts two or three months, and then a new one can be made.

The biscuit tin incinerator is, I think, preferable for use in camps close to the line when the burning of excreta is attempted. It is simple and easily constructed; no skilled labour is required, and it is inexpensive. These closed types of incinerators are distinct from open ones. The closed are better for burning excreta, as they can produce more heat, and are more quickly started, not so liable to be put out by rain, and are not productive of bad odours.

This is a suitable time to say something about the different types of incinerators. They have been classed as open or closed ones. These terms are self-explanatory. They may be referred to according to their special uses as: excreta incinerators; refuse incinerators; manure incinerators. Incinerators for burning excreta should be of the closed type. And while these incinerators will also burn all the other refuse from the camp, it is not advisable to burn jam, bean, and beef tins in them, for the solder from the tins will often run together and form a cake which binds the tins and other solid refuse to the sides of the brick, and causes it to disintegrate. It is always wise to have an additional incinerator for burning tins.

REFUSE INCINERATORS.—These are generally of the open type, and there is a great variety of them to be seen in the field. They are usually made from

corrugated iron, biscuit tins filled with clay, stones from shelled buildings, sandbags, expanded metal, or heavy wire. In the construction there is no advantage in making elaborate ones, even though portable, as they are seldom, or never, carried from one area to another.

Probably the best type is that made from biscuit tins and damaged corrugated iron. It is usually left to the ingenuity of the sanitary personnel to provide incinerators, and it is wonderful what effective ones can be made by utilizing the material at hand. A 50-gallon water tank damaged by shrapnel, set on cresol drums or biscuit tins, makes a very effective incinerator. Shell holes in the advanced area can also be used. (See figs. 49-53.)

MANURE INCINERATORS.—These are built so as to provide as large a surface as possible for the spreading of the manure, and it is advisable to have them built high from the ground so that a good draught may be procured. A popular variety is known as the "bedstead." This consists of wire placed on cresol drums, and made in sections which can be linked together. (See figs. 54-55.)

Whichever type of incinerator is in use the greatest attention should be exercised in keeping everything around as clean as possible. All tins and everything brought to the incinerator should be burned. There is no excuse for having anything unburned in the vicinity, otherwise flies will be attracted.

In billet towns there should be one large incinerator, or rather several incinerators close together at a convenient spot situated at the outer limits of the town. All units should be instructed to bring refuse there every morning, where it can be burnt by "P.B." men under the Town Major.

Very often around incinerators a great deal of material is dumped that can be salvaged. To prevent waste Salvage Companies generally have men detailed to pick out coats, boots, cartridges, &c., that may be of some use. The cartridges, however, are a danger

if accidentally put into an incinerator, and many injuries have occurred in this way. Care should be taken by salvage men not to allow any of this material to be placed in the shed for keeping the material to be burned. Arrangements should be made that all articles salvaged be removed from the neighbourhood of the incinerator at once, as otherwise a nuisance is created. The burnt tins should not be allowed to accumulate too close to the incinerator. The men in charge of the incinerator should always be instructed to set aside cresol drums or petrol tins, as they can be made use of in constructing urinals, latrines, and incinerators. The smaller tins are valuable for making roads and paths, or putting in soakage pits.

BURIAL OF EXCRETA.—The second method of disposal of excreta is by burying. This is an old and, if properly carried out, a satisfactory method. In ancient times excreta was disposed of by simply spreading it on the land as a fertilizer, a method, of course, very objectionable and very dangerous to health. Occasionally one still sees this being done, but it should not be tolerated in small communities. The nuisance can be remedied by applying to the French Mission.

Disposal by burial is carried out by means of deep trenches. When excreta is deposited in deep trenches the material is at once attacked by bacteria present in the earth, and after a shorter or longer period the faecal matter disappears. The soil bacteria can as a rule kill off the disease-producing germs in three or four days. The bacteria that inhabit the deeper layers of the soil do not break up and dispose of the excreta as completely or as satisfactorily as the bacteria in the upper layers of the soil. For that reason the use of shallow trenches not deeper than 2 ft. gives more perfect results. There is not as much liquefaction, and no foul-smelling gases are produced. This method of shallow trenches is only applicable to small units and is very seldom employed at the Front, except in some cases where the underground water is near the surface, and deep pits are out of the question. Pits, 10 ft. or

12 ft. deep, 20 ft. or 30 ft. long and 1 ft. 8 in. wide, should therefore be used in all cases.

The latrine accommodation varies in permanent and temporary camps, in the former 8 per cent. and the latter 5 per cent., these figures representing either yards or seats. It is more desirable to have one or two large latrines than several small ones, as they are much easier looked after. In camps occupied for a few days only the trenches need not be more than 3 ft. or 4 ft. deep, and in these cases, as it is impossible to have seats made, it is necessary to take every precaution to prevent flies from getting access to the faecal material. This is done by making every man throw some dry earth in the latrine after using it. If this is neglected it may be advisable to post a permanent sentry on the latrine. Care should also be taken not to soil the sides with urine on account of the danger of the urine-sodden mud often loaded with disease germs getting on the boots and thence to billets.

A very common practice that should be watched for is that of kicking some earth in the trench from the sides. Often the only way to remedy this is to take disciplinary action against those offending. If these trenches are properly looked after, it is not necessary to use any disinfectant. If, however, cresol is available, it is well to sprinkle the sides with a 5 per cent. solution. The trench should be narrow enough—1 ft. to 1 ft. 6 in.—so that men may straddle it; or a pole supported by forked uprights may be conveniently arranged as a seat. When latrines are filled up to within 8 in. of the ground level they should be covered over with earth. A rear party should always be left behind to close the latrines and mark the ground "foul," so that succeeding units may not select the same place. On the march, when it is impossible to dig trenches, men should always cover up their excreta with an entrenching tool or any available implement such as a piece of wood or tin.

LOCATION OF LATRINES.—Latrines should be so placed

that there is no danger of contaminating water supplies in the vicinity either by direct soakage from the trench, or indirectly by surface water in wet weather overflowing from the trench or its neighbourhood. It is astonishing how often units will place latrines on the side of a small stream or near a well or spring. This is very important, and you should always watch the situation of latrines or urinals to see that they are located so that the direction of the ground water or any soakage is away from the springs, wells, or water-courses, and that they are never closer than 100 yards from kitchens, food stores, or tents. When camps are located in or close to woods latrines should be placed comparatively near the billets, for if they are too far away men will not use them, and will invariably foul the ground in the vicinity.

There is always the greatest trouble in preventing men from going into the hedges or bushes or woods close to camps, and it may be necessary to put such places "out of bounds" or have picquets on them.

FLY-PROOF LATRINES.—Latrines are usually spoken of as being "fly-proof" or "open." The latter should only be tolerated under conditions, as already mentioned, that is, on the march or in temporary billets. And when they are used the excreta should be covered frequently with earth, and the vicinity sprayed with 5 per cent. cresol or treated with lime. (See figs. 9-22.)

"Fly-proof" latrines are used with deep pits or pails. Where deep pits are used some sort of a box arrangement must be provided to keep flies out of the trench. This can only be done if the covers are made to fall automatically. It seems a very simple matter, yet one has only to visit many camps to see how often latrines supposed to be fly-proof are usually open.

The remedy is to have a strong bar of 2 in. by 4 in. material along the back of the latrine so that the lids will stand a good deal of pressure against them. Small blocks of wood behind the lids are useless, as they are easily broken off, and such requests as "Please

close the lids" should not be considered as making fly-proof latrines, because little attention is ever paid to them. Men going to the latrines often take advantage of the opportunity to louse themselves; they lean back against the lids, which must be strong enough to support them. (See figs. 10, 11, and 12.)

The sides and ends of latrines should also be "fly-proof," that is, without any openings or cracks, and there should be no possible means of flies getting access to the trench. Biscuit boxes, 50 lb., set on frames are advisable, but should be tin-lined, or at least possess a urine shield in front to prevent urine from getting into and soaking through the woodwork. It is often a very difficult matter to obtain enough material to make "fly-proof" latrines, and very often substitutes for wood must be used. A frame of wood with sides and ends made of four-gallon petrol tins is very satisfactory; the sides may also be sheeted with corrugated iron or canvas if nothing else can be found.

Sandbag latrines with a wooden cover may be resorted to at times. (See fig. 19.) The type known as the "squatting latrine" should not be used. It is exceedingly difficult to keep clean, and the floor gets covered with mud and fouled with excreta, which is very dangerous. The lids very seldom are self-closing, and on the whole this type is very unsatisfactory; they may be employed in Indian and Chinese labour camps, as these races are accustomed to squatting, and will stand on any other kind of latrine provided for them. (See fig. 16.) Latrines can conveniently be made in batteries of four, or as two-seaters and one-seaters. The latter should be constructed of very light material when intended for the trenches, and to be easily carried up by one man.

PAIL LATRINES.—Pail latrines are used when the excreta is to be incinerated, or when the ground in which the camp is situated is so limited that deep trenches cannot be employed, or when the underground water is close to the surface of the ground. (See figs. 13, 14, 15, 17.) In any case the pails must be made

"fly-proof." If the latrine is boxed on all sides the pails should come up close to the seat, so that there is no danger of the solid or liquid discharges getting on the floor. In fixed camps it is of great advantage to have the floor of concrete.

Paper should always be provided in a proper box, and no "camp butterflies" allowed to blow all over the area. The buckets may be provided with sawdust, which will help in the burning, or coal oil, which in addition keeps flies away, or a solution of cresol, 2 oz. to the gallon, or dry earth may be employed. These measures are, of course, not always possible in the field.

Where there is a scarcity of lumber individual seats may be made for pails in such a way that covers close automatically. If it is difficult to get the ordinary issue latrine pails, petrol tins or cresol drums may be substituted. These latter are preferable for use in the line, as they are lighter and can be more easily handled by one man, and are cheap and always available. The large pails when full require two men to carry them, and for this purpose two poles may be arranged like a stretcher, substituting for the canvas two clasps of iron to fit around the pail.

The pail system is sometimes adopted in billeting villages, and arrangements are made with civilians to take away the contents of the pails in what are called vindage carts—large iron carts with tightly fitting covers. These pails are emptied at least one half-mile from the village. This practice is often objectionable if the cart is not watertight. When this system is in use two sets of pails should be employed, so that while one set is being emptied and cleaned the other set is in action. In cleaning the pails should be washed with a solution of cresol 5 per cent., then brushed over with oil. The woodwork on the latrines should be carefully scrubbed at least twice a week with a solution of cresol. "Lime" which is with difficulty obtained should not be thrown into or around latrines or urinals indiscriminately.

In deep pit latrines where you depend upon bacterial action the disinfectant will kill the bacteria, and no purification will take place. If, on the other hand, it is desired to disinfect the trench and its contents or prevent flies from being attracted to the latrine, the trench, bucket, and surroundings may be sprayed with a 5 per cent. solution of cresol.

SELECTION OF TYPE OF LATRINE.—In deciding on the type of latrine to be used much depends upon the situation. At the base, on the lines of communication, and in the Divisional reserve area the pail system may be used in conjunction with incinerators. In billet towns for the brigades in rest deep pits with fly-proof latrines are the most satisfactory where there is enough ground available. It is not desirable to use civilian latrines, and arrangements should always be made for separate latrine accommodation. If it is necessary for the reasons already given to use pails, the contents must be buried as far away from the camp as possible. There is absolutely no excuse for using pail latrines and burying the contents of pails 10 ft. or 15 ft. distant. It is just as well, and much more sanitary to instal a deep pit latrine with "fly-proof" covers at the outset.

LATRINES FOR TRENCHES.—For the front line, support, and reserve trenches fly-proof deep pit latrines should be used where possible. At one time it was considered necessary to have the pail system, but the former is much more satisfactory. There is a great deal of extra work required to empty the pails which are seldom properly cleaned and washed. The fly-proof covers that are provided for pails, petrol tins, and cresol drums are very often lost or not used, and consequently it is an open latrine.

Deep pit latrines can even be satisfactorily introduced in crater posts or advanced saps. A very convenient portable latrine for the front line is made, and you will see a sample of it in the exhibit. It is simply a biscuit box or a biscuit box arrangement fly-proof that can be placed over a trench; or if no trench is

desired, a pail is placed inside the box. This is a much better fly-proof scheme than the cover made to fit over the pail, and as I have already said, a cresol drum is preferable to the issue pail on account of its lightness and convenience for handling. (See figs. 21, 22.) If pails are used they are generally emptied into shell holes twice daily, about dusk in the evening and about daybreak, the contents being covered with earth. These one-seated latrines can be obtained at the Sanitary Section or made at the transport lines by pioneers and sent up to the advanced ration dump; from there they can easily be carried up to the line.

The latrines should be so camouflaged or simply constructed as not to simulate a machine-gun emplacement or trench mortar position, or a sniping post. A great many casualties have occurred at latrines largely on account of this simulation. A suitable place for a latrine would be in a sap about 15 ft. or 20 ft. from the firing trench. The situation of latrines and urinals should always be properly indicated by directing signs which can be obtained from the sanitary workshop.

DISPOSAL OF URINE.—The proper disposal of urine is just as important as the disposal of the solid excreta, because urine may contain countless millions of germs causing disease. The great danger of infective urine is not sufficiently realized by the majority of men, and there is far too much indiscriminate urinating in the vicinity of the huts, billets, and other places. Unfortunately, the example set by many of the civilians in this country is not one that can commend itself from a sanitary point of view.

Urine should be disposed of in closed soakage pits, 6 ft. to 8 ft. deep, and 3 ft. or 4 ft. square, according to circumstances. The pit should be filled with broken brick or rubble or burnt tins from the incinerator. These latter are always available, but when used they should be perforated in several places so that they will not hold the urine. The urine may be received into gutters made out of corrugated iron, or wooden gutters tin lined for large units; for small units very

satisfactory ones can be improvised from petrol tins or cresol drums. (See figs. 1-8.)

In all cases there should be a waste pipe leading to the bottom of the pit, and if the soil is fairly absorbent, the urine will disappear. If it is not absorbent, there will be more or less purification as the urine comes up through the tins, and it can be run off by means of a syphon into a second and third pit if necessary.

It is always desirable to have the opening where the waste pipe joins the urinal covered with perforated tin to prevent matches, cigarette ends, &c., from getting into the pipe and blocking it. Small drip cans can be arranged and fixed in the upper portions of urinals, so that ten or fifteen drops per minute of oil or solution of cresol may be distributed over the urinals, thus discouraging flies. These soakage pits may be placed quite near huts and tents, and thus can take the place of the customary urine tubs that are often allowed to overflow, and are liable to be spilled while being removed.

Occasionally urine pails may be necessary when men are billeted in large factories or buildings of several stories, when it is too much to expect that the men will go far outdoors, especially if the weather is unfavourable. The pails in these cases should be removed early in the morning, care being taken to avoid spilling or splashing; the contents should be buried in a trench and well covered over with earth.

Open trenches should not be used as urinals. It is impossible to prevent the sides of the trench from getting soiled with urine. The consequence is that the sodden mud gets on the men's boots, and infected germs are thus brought into the kitchens and billets. These open trenches are also very attractive places for flies.

The types of urinals just mentioned may also be used in the front line area and in the long communicating trenches. Urinals for trenches are preferably dark in colour, as they do not show up so well on aeroplane photographs.

Urine soakage pits should when constructed near latrine trenches be separate, as there is much less likelihood of having foul-smelling gases develop in the latrines. Soakage pits should not be situated close to wells or streams; in the former case, if constructed, care should always be taken that the subsoil water is directed from the wells towards the pits. All urinals should be frequently sprayed with a 5 per cent. cresol solution or kerosene during the fly season.

DISPOSAL OF SULLAGE WATER.—Sullage water includes the waste water from kitchens, ablution tables, bath houses, and laundries. There are very few more unsightly things in a camp than the indiscriminate throwing on the ground or in trenches of the waste water from kitchens, or the feeble efforts made to dispose of the water by simply pouring it into a pit in the ground without any attempt at purification.

Sullage water has always been hard to dispose of on account of its containing fat, greasy matter, and soap. These materials when undergoing decomposition around camps are very offensive, attract flies, and pollute drinking water if allowed to go into streams without treatment. When sullage water flows into a pit the greasy and fatty matters, if the soil is absorbent, soon form on the sides of the pit and bottom an impermeable coating that prevents any soakage. If the pit is dug in clayey soil or a non-absorbent soil like chalk, it rapidly becomes filled up, and the effluent, unless treated with something to remove grease, becomes a nuisance.

The extent of the treatment frequently consists in pouring the sullage water into a cresol drum or box with perforated bottom, filled with straw, or grass, or rubble, and set over a pit in the ground. (See fig. 23.) This is a very crude and unsatisfactory method. The straw, hay, or rubble does not remove all the greasy material, and the result is that the pit becomes impervious and necessitates the making of new pits. In this way a great deal of ground becomes unnecessarily fouled in a camp. Hay, straw, and

grass catch a certain amount of grease and fat, but not enough to ensure good soakage.

Experience in this war has shown that the best and most efficient and satisfactory way of dealing with sullage water is to treat it first with chloride of lime in one chamber, and then allow the water to pass through a filter bed. (See figs. 25 and 45.)

The chloride of lime causes the grease to separate very quickly and rise to the surface, from which it can be skimmed daily or as often as necessary; a clear water is left below, which is conducted by means of a syphon to a second chamber or a pit filled with rubble, pebbles, and sand.

These second pits or filter beds are prepared by having large rubble below, then pebbles, and on the top at least 4 in. of sand. Here there is upward filtration, and as sand is the best filtering material available, the effluent is perfectly clear, and, being chlorinated, can safely be discharged into any ditch or drain. If broken brick or rubble cannot be obtained, perforated burnt tins may be substituted.

The sullage water from kitchens may first be poured into a box with a strainer to catch large particles of food; the box with a perforated bottom is placed over a small pit in the ground, where the chloride of lime can be added and stirred. The strainer is made from tin which is perforated, and the boxes arranged with a self-closing lid to make it fly-proof. In the box beneath the strainer hay or straw may be used to catch some of the grease, and this is burned daily. The syphon should go to within 3 in. or 4 in. of the bottom of the small pit and to near the bottom of the large one, so as to ensure an upward filtration.

The dimensions of the pits will depend upon the size of the units. An empty petrol box is large enough for company cookhouses. The first pit is a 3-ft. cube, and separated from it by a yard or more, according to circumstances, is the second pit, usually 10 ft. long by 3 ft. wide and 8 ft. deep. The size of the pits will, of course, vary with the amount of liquids. The

chloride of lime should be added daily in the proportion of 1 per cent. by volume. Stirring is necessary until the greasy and soapy matters show signs of bleaching. The amount to give the best result will very soon be arrived at by the detail told off for this purpose.

The use of pits rather than box is desired as being cheaper, and they are also more easily constructed. There is no reason why this method cannot be adopted for all sullage water, whether in connexion with kitchens, ablution tables, baths, or laundries. The greasy scum when removed may be dried and burnt in the incinerator or buried. Whenever chloride of lime is used for this purpose cresol should not be added, as it interferes with the scum.

ABLUTION WATER.—Ablution water may be disposed of in exactly the same way. A waste pipe from the ablution table should lead directly into a small pit at the end of the table to which the "lime" is added, and a second pit is arranged as a filter bed. The short arm of the syphon goes to within 3 in. of the bottom in the first pit and close to the bottom in the second. The filtering material consists of burnt perforated tins, broken brick, rubble, pebble, and 6 in. of sand on the top. This allows an upward filtration, and the effluent may be used again or safely discharged into a watercourse.

In connexion with the sand on the top of the filter bed, I might mention that it is well to have it covered with coal cinders or rubble, as if it is exposed the men will certainly use it for cleaning their mess tins. Apart from the interference with working of filter bed, this is, of course, a very dangerous practice. The junction of the waste pipe with the ablution table should be covered with perforated tins to prevent pieces of soap and other toilet articles from getting into the pipe. The chloride of lime should be added daily, the mixing tank skimmed, and the scum burned or buried.

Ablution tables can be very simply fitted up with a board rest to hold soap and mirrors, thus adding

greatly to their usefulness and convenience. (See figs. 43, 45.) I should strongly advise you to adopt, and recommend, this plan. It is much more effective than any other method. The materials required can always be found around every camp; no skilled labour is required; the small quantity of "lime" can be easily obtained; and it gives a clear, chlorinated effluent without offensive odour, that can be turned into a stream without danger, or it may be used over again for washing or cleansing purposes.

You will be shown in the workshop plans of the different arrangements required for small and large units, and you will also see the satisfactory effluent that comes from such an installation at a bath house.

DISPOSAL OF SULLAGE WATER IN THE TRENCHES.—In the shelled area it is impossible to expect that any such system as this can be introduced; the most that can be hoped for is to have all sullage water placed in a covered receptacle, which is emptied at convenient times into shell holes or pits and covered over. Sometimes even this cannot be done, and the only procedure is to throw the water as far away from the dug-outs as possible over the parapet or parados.

THE EVAPORATION OF SULLAGE WATER.—A very successful method of disposing of sullage water from kitchens is that known as the evaporation method. It can be adopted where trench kitchens and camp kettles are used. A pit 5 ft. deep, and 5 ft. 6 in. wide, and 2 ft. or 3 ft. long according to circumstances is dug between the distal camp kettles and the flue, and a perforated tin may be used as a grease trap through which all the water about the cookhouse is poured before going into the pit. The great heat of the fire passing over the exposed surface of the water and the heat around the flue causes a rapid evaporation on the broad surface exposed. A certain amount of water depending upon the nature of the soil soaks away and the rest is evaporated. It is a cleanly, sanitary, and time-saving method, that should be more frequently adopted. (See fig. 41.)

DISPOSAL OF REFUSE.—The refuse of a camp consists of such things as kitchen garbage, paper, sacks, tins, cigarette boxes, orange peelings, and general rubbish. It is essential for cleanliness and health that the refuse should not be thrown on the ground where it may be blown all over the camp or left exposed to flies. There should always be separate receptacles for dry and liquid refuse. These should be fly-proof and water-tight if possible. In camps cresol drums or biscuit tins with tightly fitting covers may be used and placed near every row of tents; in billets or barracks sacks should be placed outside the doors and removed daily to incinerator, and contents burned. Sacks when employed, if tins are not available, should be provided with fly-proof self-closing covers. In the trenches sandbags are the best kind of receptacles, and every dug-out should possess one hung on a nail outside. (See figs. 38, 39, 40.)

There should also be sandbags at regular intervals along the different trenches, and all ranks should be instructed to put refuse or rubbish in them. (See figs. 36, 42.) A very bad practice is sometimes seen in the trenches, namely, the throwing of bits of food, orange peelings, cigarette boxes, papers covering chocolates, and biscuits, empty jam, bean, and bully beef tins, on the bottom of the trenches or under duck boards, or even over the parapet or parados. If this practice is permitted it invariably means tremendous numbers of flies with a high sick admission rate. It is certainly an easy enough thing to put all this rubbish in proper receptacles that can be removed to shell holes at opportune times and buried. On no account should this refuse be dumped in latrine pits, as is too often done. Regular refuse dumps should be established at convenient places in the trenches, where all this material may be buried. In camps where the incineration of fæces is carried out the dry refuse is very valuable as a source of fuel.

Solid kitchen refuse should also be placed in proper fly-proof receptacles and taken to the incinerator,

where it is burned and buried. The large particles of food caught by the strainers in grease traps should also be burned. It is possible in some villages behind the line to give the kitchen refuse to farmers to feed the pigs. If this is permitted, the greatest care is necessary to see that all refuse is removed in a cleanly manner, that it is not spilled about in the camp or near the billet, or along the roads, and also that the farmer comes for it once or twice a day at regular hours, whether it suits his own convenience or not.

When kitchen refuse is stored in tubs, barrels, or boxes, they should always be furnished with tight-fitting covers, and should be raised on wooden stands close to cookhouses, the stands to be made of four short posts supporting a rough wood framework. They should not be put flush up against the wall or in dark corners of buildings, as in such cases a great deal of refuse gets on the ground behind the receptacles, which, besides being unsightly, attracts flies. In many cases the receptacles may be set on small concrete platforms raised some inches above the ground level.

In billet towns it is advisable where possible to have the military remove all civilian refuse in the morning. On account of the shortage of labour it is impossible for the municipal authorities to remove household refuse frequently enough; that accounts for the way in which the streets get littered with all sorts of rubbish and waste material, giving rise to offensive odours and attracting flies. It is also wise to have large refuse receptacles, fly-proof and watertight, placed near *estaminets*, Y.M.C.A. huts, and cinemas.

DISPOSAL OF DEAD ANIMALS.—The disposal of dead animals is a difficult and tedious problem. The amount of time taken and labour required is not inconsiderable. Under certain circumstances where there have been heavy casualties among horses special fatigue parties must be told off to bury them. To depend upon the unit concerned in these cases very often means that the bodies may be left unburied for

days. This has happened in some recent fighting on the present Front.

There are two methods usually recommended for dealing with dead bodies—burning and burying. The first, though the most satisfactory, may be dismissed at once as being impractical in the field, because large incinerators are required and much fuel. The only course left is to bury the body. One very necessary procedure previous to burying is to slash open the intestine so that gases may escape. Then the body should be buried as deeply as possible, 8 ft. or 10 ft. It is a great mistake to dig a shallow pit close to a road or near dug-outs and tumble a horse in with a covering of 3 ft. or 4 ft. If that is done there is sure to be a nuisance. Gases formed in the body will cause a swelling to take place; the earth becomes opened and flies get access to the dead body, while very offensive odours are produced. Much trouble was experienced in one Division from this method of disposal, and it became necessary to put fresh earth over the sites and spray the ground daily for some time. A good solution to make use of in these cases to keep away flies and prevent the development of odours is what is known as "C solution," which can be obtained from the Senior Supply Officer through indent by Quartermasters. A 5 per cent. solution of cresol also gives good results.

When time permits and materials are available you can combine burning and burying. The body is disembowelled, and the viscera buried and covered with 2 ft. of earth. The body is then filled with straw, kerosene being added, and set on fire. This destroys the greater part of the body, and what remains can be buried in shallow pits.

If the animal should have died from a disease like anthrax or tetanus, it would be necessary to disinfect the surface of the ground where fouled by the blood of the animal. This is one of the advantages of the burning method in such conditions; otherwise spray with "C solution" or 5 per cent. cresol. The pre-

paration known as "C solution" gives excellent results when no other method of dealing with dead animals can be applied. When the body of a dead horse is much decomposed several applications of the solution sprayed on will remove the smell, kill flies, and prevent putrefaction. If there is no time to dig pits, the preparation may be injected into one of the larger arteries in the neck, and if this operation should prove difficult the abdomen may be opened and intestines slashed to let out gases, and the fluid poured freely into the cavity. The body should also be sprayed. Putrefaction will be delayed for nearly two weeks and no odour produced.

LECTURE V

Flies and Lice

I cannot too strongly impress upon you the importance of adopting all possible measures to combat the fly nuisance. A great deal has been written, and you have often read, and have been told, of the great necessity of continually keeping up the fight against one of our particular enemies, the fly. Why is so much attention paid to flies, and why are you continually being asked to have certain fixtures made "fly-proof"? For the very good reason that it has been shown positively that flies spread disease.

What are the fly-borne diseases? The diseases—to repeat once more—spread by flies are: typhoid fever, paratyphoid, cholera, dysentery, diarrhoea, erysipelas and conjunctivitis, the latter being an inflammatory condition of the eyes. It has been stated that flies in addition carry the germs of tuberculosis, anthrax, and plague. Trench fever, the condition known to many of you as P.U.O., may also be due to flies. This

disease is caused by a germ, and the infection may be conveyed by flies or lice.

Are we sure that flies really cause disease, and should we take measures to destroy or prevent flies from breeding? There is nothing of which we can be more certain. The germs that cause cholera were found on the flies examined in a sick room during an epidemic of this disease in Hamburg. The germs that cause tuberculosis or consumption were found on several flies collected from a room in which a consumptive person had lived. The germs that cause typhoid fever were found on the legs of flies three weeks after the flies had been infected with the organisms. Flies carry germs on their feet, and this is proved by a well-known laboratory experiment of allowing a fly to walk over the plate of gelatine, a substance on which germs readily grow. At the end of a few hours every footprint is shown in parallel lines of growing colonies.

It was proved as long ago as 1850 that flies caused some cases of cholera on a British ship stationed in the Mediterranean. This ship, having no sick on board, called at the port of Malta. No person from the boat went on shore, and there was absolutely no connexion of any kind between the people on the ship and those on shore. No water or food supplies were brought on board. At the time, however, there were some cases of cholera in Malta, and it was noticed by everyone that a great many flies from the port swarmed around the boat. After a short period in the harbour the ship put to sea again, and at the end of three days, which is the incubation or hatching period, some cases of cholera developed. These were undoubtedly caused by flies, and no new case developed when they had been five days out at sea. During the winter when there were no flies the ship, though constantly running in and out of the Mediterranean ports, developed no cholera. Several attacks of typhoid in India were also clearly traced to the agency of flies.

Flies get a great deal of infective material, that is

germs, from latrines. A very notable connexion between typhoid and flies occurred in a town in England. This town had three different methods of dealing with excreta, namely, water-closets, pails, and middens. It is well known, of course, that it is very easy for flies to get access to middens, less easily to buckets, and with difficulty to water-closets.

During a period of ten years it was found that the ratio of liability to contract typhoid was ten times as great in the houses with middens; and nearly four times as great in the houses with the pail system as in the houses with water-closet accommodation.

LIFE-HISTORY OF FLIES.—I think that perhaps it would be wise to tell you something of the life-history of the fly. The fly in its life goes through different stages. It begins as an egg or ovum, and at the end of twenty-four hours usually passes into the next stage known as the larva or maggot. Then within a week the maggot becomes the pupa or chrysalis, which is an intermediate stage, and at the end of three to five days the adult fly is formed. Complete development takes place generally from ten to fourteen days, though in very hot weather it may be accomplished in seven days. A very remarkable thing about the ordinary fly is that its body and legs are covered with a great many hairs. These can properly be seen under the microscope. And it is on account of these hairs, moistened with a sticky material, that flies are able to transport or carry around such a large number of germs.

KINDS OF FLIES.—The flies that are chiefly responsible for disease are of three kinds, namely: house flies; blow flies, or blue-bottles; and latrine flies. All flies lay their eggs in moist, warm places, usually in fæcal material which is fermenting, and thus giving the heat necessary to development. It is also easily digested food. The manure from horses is a favourite breeding place, more so than cattle manure, which has a tendency to cake. It has been frequently stated that 90 per cent. of all house flies lay their

eggs in horse manure, and this is important, as it gives us a clue in the treatment to be adopted. House flies also lay their eggs in fermenting vegetable refuse and kitchen rubbish heaps. Latrine flies breed in the same places and in human excrement. Blue-bottles are supposed to have a special preference for decaying flesh, bones, dead bodies, bean, and bully-beef tins.

DEVELOPMENT OF FLIES.—The maggots of flies need moist conditions in order to develop, but when full grown they seek a drier place, or may burrow into the ground 2 in. or 3 in., where they change into a hard brown-like substance or pupa, within which the fly develops. Flies reproduce very rapidly. It has been estimated that a female fly lays one hundred and fifty eggs at one time, and that within a month she may produce half a million flies.

INFECTION CONVEYED BY FLIES.—How can flies transport disease-producing germs? Flies, as you have just been told, feed on excreta, 1 gr. of which may contain sixteen million germs; they may feed on sputum or wounds. From there they go to the kitchens, where they contaminate food, drink, and cooking utensils by means of the germs carried on their feet, in their crops, or dropped with their excreta. A single fly may contain in its crop as many as twenty million germs capable of causing typhoid fever.

PREVENTION OF FLY-BORNE DISEASES.—You have been told how flies may cause disease. You have been told something of the life-history of the fly, its development, and habits. And now the great question is how to prevent flies from causing disease. This is a large problem when one considers the enormous number of men and horses that are concentrated in the areas occupied by the Army in the Field. Among the thousands, the millions, of men there must be many carriers of disease; there must necessarily be a certain number of fly-borne diseases; and there is an immense quantity of horse manure and other waste

matter, the breeding places of flies, so that there is every encouragement for their growth and development.

But fortunately on account of the great attention paid to sanitation by all ranks, on account of the coöperation existing between all branches of the Service, great as the problem of controlling fly-borne disease is, it has been solved. However, that is no reason why you should feel that your efforts may be relaxed, or the slightest armistice permitted to occur in the fight that must always be maintained against flies.

THE FIGHT AGAINST FLIES.—The fight against fly-borne disease is conducted along three great lines:—

(1) Prevention of fly breeding and killing of flies; (2) prevention of flies getting access to infective material containing germs; (3) prevention of flies getting access to food and cooking utensils.

With regard to the prevention of fly breeding, you know that the greatest breeding place is horse manure. What, then, is the proper treatment of horse manure?

TREATMENT OF HORSE MANURE.—There have been a great many methods of dealing with horse manure tried in this campaign, and I shall describe the most successful, merely mentioning some of the less satisfactory. The most successful method is that known as "close packing." This consists in making heaps of the manure very much like the farmer does to allow fermentation to occur before putting it on the land. The idea is that when fresh manure is close packed fermentation sets in, a great deal of heat is generated, and the fly larvæ will not develop. It is necessary to pack the manure tightly and to see that the surface is beaten down firmly. This is essential to success. The size of the heap generally made is 10 ft. long and 10 ft. wide by 5 ft. high. When the manure heap has been completed it is always well to cover the top and sides with a foot of earth well packed and beaten down with a shovel. The spraying of the heap every evening with cresol, 1 volume; kerosene, 20 volumes,

made up to 100 volumes of water is of great assistance in preventing the breeding of flies. This method gives good results and is quite practicable.

In villages manure dumps should be selected well outside the town, if possible 600 yards. It has been noticed that flies will not travel much further than this distance or perhaps 1,000 yards if hungry. It is an advantage to have one or two "P.B." men at every dump to see that the treatment is properly carried out. If certain units have no wagons the Town Major can always call on some other to provide the necessary transport. Manure from individual horses should always be placed in sandbags outside the billet so that it can easily be removed. In many cases it may be possible to lay narrow gauge railways and run cars from stables, where there are many horses, to the dump.

Though the manure from the military may be properly looked after, there is always the trouble with the middens of the farmers in the villages. This problem can usually be satisfactorily arranged if properly dealt with. In nine cases out of ten, if the farmer is approached quietly and diplomatically, he will listen to your request, and when the reasons are explained to him he will generally comply with your wishes. If there is difficulty in getting the manure removed it can always be sprayed with cresol 5 per cent., as well as the ground, for at least 2 ft. around the manure heap. The small quantity employed will not have any effect on the manure from an agricultural point of view, and there is no danger of its affecting the water in the well, which is always so close to the midden.

Another method available for dealing with manure in civilian middens has been authorized, and that is digging pits 3 ft. deep in the ground, as far as possible from billets and cookhouses, and dumping the manure in these pits, covering each load with a layer of earth taken from the pits and piled on the surface. Men

and horses can be demanded by the Town Major for this purpose.

TREATMENT OF HORSE MANURE IN ADVANCED AREAS.—A very satisfactory method of treating manure in advanced areas, in the vicinity of old disused trenches, or in the area taken over from the enemy after an advance, is to dump the manure every day in the old trenches not now required, and at once cover the manure with earth from the sides, taking care to pack it down. This method has been employed with great success after some of our late offensives, and it is remarkable how few flies are to be seen in these areas. It has the advantage also of filling up the trenches and allowing them to be bridged at frequent intervals.

INCINERATION OF MANURE.—This method is not applicable on a large scale, and at best can only be employed during the hot days of the summer. But in a European climate such as we have here it is not to be depended upon. It is, of course, the most satisfactory method there is, except that the value of the manure is lost to the country. It is very well adapted for small units, and you will see in the exhibit types of incinerators employed for the purpose. An incinerator made from a bundle of old wire may be employed. A very common one is that known as the "bedstead." Large meshed wire netting is placed on iron bars, supported on cresol drums or biscuit tins. They are easily erected, and the material can always be obtained. These incinerators work well if put on the top of heaps where they are exposed to the wind. The fire may be helped along with a little kerosene. When burning well manure to the depth of two and a half feet may be added. The ashes are removed from underneath the grate, and with a little care on the part of the attendant the fire can be kept on indefinitely. These methods can only be employed by smaller units, as otherwise too much labour and material would be required. (See figs. 54, 55.)

SELLING MANURE TO FARMERS.—The giving or selling

manure to farmers is seldom successful, as the farmer will not come regularly every day for it. He may occasionally be stimulated if you set the manure on fire, for then he realizes its agricultural value will be lost to him. If manure is hauled away daily from the horse lines to a distance of about a mile, and thinly spread on the ground, there is very little danger, as in this way there is not much fermentation, and conditions are not favourable for the development of the fly.

I might here say a word about a very bad practice frequently seen, that is, the spreading of night soil—the contents of middens or privies of civilians—on the ground close to billets or camps occupied by soldiers. This is a very dangerous custom and should never be allowed. When it is necessary to clean out these places the contents should be taken well away from billets or other buildings, and buried in deep pits or spread on the land at least half a mile away.

If there is any difficulty, all that is necessary is to have the matter reported through the regular way to an officer, who will in turn report to Division, and the matter will be taken and remedied by the French Mission.

Several other methods of treating manure have been advocated at different times, such as the application of borax in the proportion of one pound to 15 cubic feet of manure, chloride of lime, sodium arsenite. These chemicals may be a source of danger to wells in the vicinity of middens, and as borax and lime cannot be obtained, they are never employed.

STABLES AND HORSE LINES.—While speaking on this question, I would like to say that stables and horse lines should not be placed too close to billets, huts, kitchens, or dining rooms. Of course, in some instances on active service it is difficult to have horse lines as far away as one would like, but in cases where they are fairly close, often within 100 or 200 yards from kitchens, the greatest care should be taken to keep the stables as clean as possible. Spraying all

the standings frequently with a solution of cresol is invaluable.

Picquet lines should be burned over once a week. In dealing with the manure question you should always see that manure is removed from stables or standings every day. If this is not done there is sure to be a greater or lesser accumulation; and it is always more difficult to keep the lines in a satisfactory state if the piles are allowed to get too large, as it will take a strong fatigue party to remove it, and several days may elapse. On no account allow manure to be thrown in large heaps at the foot of the horse standings. In the first year of the war this was done, and, apart from the great danger of fly breeding, it indicated carelessness and lack of cleanliness.

FLY-BREEDING IN GARBAGE.—While ninety per cent. of the flies lay their eggs in horse-manure there are other places to be looked after as well, namely, garbage, kitchen and other refuse, jam, bean and bully-beef tins. Garbage refuse and dirt of any kind should not be allowed to lie uncovered in a camp or lines. It should always be placed in proper receptacles until removed. Liquid kitchen sullage should be kept separate from dry garbage. All dry garbage should be burnt in an incinerator as soon as possible. All receptacles used for garbage must be regularly cleaned.

In a clean camp where all garbage is properly burned and buried you never see a fly. In other words, a clean camp is the greatest enemy to fly-breeding. If it is impossible to burn garbage in shelled areas, it should be buried in a trench or shell hole, and covered over with a layer of earth at least a foot deep. Flies are generally attracted to kitchens; hence the reason for having floors and tables kept clean. No grease, fat, or organic matter should be left exposed to the flies. All tables, meat blocks, or any cooking utensils should be cleaned immediately after use. Flies also breed and get their food in excreta. The greatest care must be exercised regard-

ing the disposal of excreta. All latrines should be made "fly-proof." How this is done will be dealt with at another time. It is sufficient to say now, that since human excreta forms a breeding-place for flies, the correct thing is to make it impossible for flies to get into the latrine. Make it "fly-proof."

TREATMENT OF ADULT FLIES.—This is the next point to be considered, and there are a great many methods mentioned in different books and employed by different units. The killing of adult flies cannot be prosecuted with much vigour by the fighting units, but a great deal can be accomplished in rest camps, on the lines of communication, or at the base.

Flies may be destroyed by fly "swatters" or fly switches, which can be easily and readily improvised and made use of in kitchens and messes; a disc of leather, wire gauze, or other such material four or five inches in diameter and mounted on a handle is very effective.

Fly traps can sometimes be drawn from the Senior Supply Officer and should be asked for. "Fly ballons" made with wire gauze and baited with jam or sugar are very useful. Fly papers or strings coated with a sticky material may be employed, and are very effective. The flies can be disposed of by heating the wire in a flame. The sticky material may be made by boiling linseed or castor oil or any other vegetable oil with about double its weight of resin. I do not suppose that this means will be employed by many of the men in the battalions, but I am simply giving you the formula, as it may be useful to you if you are sent to camps behind the line or at the base. The mixture consists of: resin, 62 parts; castor oil, 26 parts; honey, 12 parts. "Tangle-foot" is one of the best mechanical methods, and may be made by mixing cream and sugar in equal parts.

A solution of the best fly poison is prepared as follows: formalin, 2 tablespoonfuls; sugar, 1 dessert-spoonful; water, 1 pint. This makes an attractive solution for flies, kills them and is not dangerous to

man or domestic animals. It can be used in shallow tins or trays, and small bread crusts may be put in as a resting-place for flies. When this poison is employed it is desirable that no water should be available for flies in the vicinity.

There are other poisons, such as sodium arsenite, sodium fluoride, and copper sulphate sometimes effectively employed, but they are dangerous to man and animals, and I should not advise their use, as they may lead to the poisoning of food or water intended for human consumption. They may, however, be employed for spraying manure piles at times, and can be prepared by mixing a pound of poison with one of sugar and dissolving in five gallons of water. Pyrethrum powder dusted on windows or cupboards is said to destroy flies. A teaspoonful of it burned in a tent will cause all flies to disappear; the vaporizing of the same quantity of cresol will also drive flies out of rooms and tents.

The spraying of mess rooms, kitchens, and billets with a solution of cresol is very effective for keeping flies away from these places. The solution is said to be improved by adding five volumes of formalin, and if applied with a spray having a very fine nozzle gives better results. Some of these preparations are not available for troops in the line, but you can always get cresol, and a five per cent. solution can be employed with good results in places where flies breed or congregate.

I have now spoken of the method adopted for the prevention of fly breeding and of the means and ways of killing the adult fly, and shall now say something of the method of the second line of defence against flies, namely, the prevention of their access to infective material. If in spite of our efforts some flies do breed, then no danger will result if we prevent this small number from getting near infective material. The infective material we have to deal with, as containing germs, consists of the solid and liquid excreta of persons who are carriers or have such diseases as

typhoid, dysentery or diarrhœa, the expectoration from a consumptive, the material vomited by a cholera patient, or the exfoliations from a case of scarlet fever. The method of dealing with excreta will be dealt with separately, and the treatment of the actual sick does not come much in our work. The means of treating the various discharges will be touched upon when considering the subject of disinfection.

PROTECTION OF FOOD.—I have now come to the third and last line of defence in the fight against the fly, namely, the protection of food supplies. If flies do breed, and if they get into contact with infective material containing germs, then our only hope is to prevent them from getting near food-stuffs. This is indeed a most difficult problem, especially at the Front. Food protection can be carried out with the greatest degree of success well behind the line and in more or less permanent camps, but even in shelled areas or the trenches it is surprising how well food can be protected with a little work and effort.

In kitchens and dining rooms in the rest area where huts or buildings are available all entrances, such as windows and doors, may be made fly-proof with fine wire gauze. Butter muslin is also a valuable protective covering against flies. Food and meat safes can easily be made from the boxes that the food comes in, and these boxes can be obtained from the Quartermasters. You will see in the workshop and at the exhibit different kinds of food safes that can readily be improvised from the boxes that are always available at the Quartermasters' stores. (See figs. 28-35.) Food kept in billets close to the Front and in the support line can with a little care be also very well protected against flies. The ordinary fifty-pound biscuit box can be readily made into a safe for your cheese, bread, and biscuits. Also the biscuit tin covers of the boxes may be made with a fine wire on a frame or sacking with a weight at the bottom. These food safes may be made at the transport lines by pioneers and sent up the line. Frequently they

are made in sanitary workshops by the sanitary sections and are available on indent. In dug-outs boxes may be set in excavations in the side and thus kept cool. The difficulty here is often from rats, and generally any food safes to be effective must be covered with revetting material made rat proof as well as fly proof. (See fig. 42.)

LICE.

Let me tell you at the outset, what you all know by experience, that the louse problem is one of the most difficult, as it is one of the most important, matters that we have to deal with at the Front. There are few things that the fighting soldier dreads more than lice, and there are few things that cause him more actual discomfort or make life more miserable for him. Men have often stated that they would not mind the cold, the wet, or the long hours if they could get rid of the lice. It is therefore desirable that every possible means should be taken to destroy lice, and nothing should be left undone to free the soldier from such a grave menace to health and military efficiency.

DANGER TO INDIVIDUAL.—When a man is "loused" he is very liable to get inflammatory infection of the skin due to the continued scratching. This scratching may give rise to what is known as "louse rash," a condition very distressing, very common, and often mistaken for scabies or itch. He loses sleep, and often gets in a run-down condition, and his value as a fighter is much lessened.

DANGER TO OTHERS.—Lice within the past few years have acquired a special significance, as it has been proved definitely that they carry the germs of typhus fever, relapsing fever, trench fever, and, according to some authorities, typhoid and paratyphoid. In all the Eastern wars the louse played a great part in the spreading of typhus fever, especially in the last Balkan war, and in the Crimean war. There is no question that the terrible and fatal epidemic of typhus seen in

the Serbian army and in the civilian population during the first year of this war was due to this pest. There is always the danger of the organisms causing typhus being brought from the Eastern front by soldiers transferred here, so that if troops are to any extent affected with lice there would be great danger of the spread of this very serious disease.

TRENCH FEVER SPREAD BY LICE.—It has been definitely established that trench fever is caused by a germ which gets access to the blood. Trench fever is a well-defined disease, and is not, as has frequently been thought, a form of enteric fever. The disease is transmitted from one infected person to another by means of the bite of the ordinary body louse, and this appears to be the common means of transmission. It has also been proved that, if the body juices or excreta get rubbed into the skin through a slight wound or an abrasion by scratching trench fever may develop. The incubation period varies from five to twenty days.

TYPHUS SPREAD BY LICE.—Typhus fever is spread in the following way by lice: A louse bites a person suffering from typhus, and thus gets the germs of the disease from the blood of the person. The louse then bites another individual and conveys the germs in that manner. It has been noticed that the louse does not convey the germs of disease until nine days after it has fed on the blood of the person suffering from the disease. It is also worth remembering that the excreta of the lice contains germs, and the disease may therefore be caused by scratching into the skin the germs contained in the excreta of the lice when killed on the body.

RELAPSING FEVER SPREAD BY LICE.—Relapsing fever is very apt to be spread by lice, and, as a matter of fact, a few cases have occurred where it was introduced by troops serving in other theatres of the war. This disease is caused by a germ of the type I mentioned to you as spirilla, a curved organism, contained only in the body juices of the louse, not in faeces as in typhus. Relapsing fever is not caused directly by

the bite of the insect, but only when a scratch or bite gets inoculated by the body fluid of the louse that has been crushed in scratching. There is practically no danger of this disease spreading through the agency of lice. It is also worthy of note that when a person suffering from typhus or relapsing fever has been washed, cleansed, and freed from lice he is no longer a source of danger to others.

The louse problem is so important that it would be well to say a few words about the character and life-history of the louse itself. Many of you will probably wonder how the Army over here got infected with lice. In the early days of the war, when the men were first called to the colours, some came from the slums of the big cities, sordid and verminous surroundings, and were hurriedly gathered together in tents and barracks that must have been fearfully overcrowded. This herding together caused direct transference of infected to clean men; and on account of barracks being constantly occupied without any disinfectant new troops became quickly infected.

In this way many men came over to France verminous, and owing to the lack of bathing facilities and want of disinfectors the lice very quickly reproduced, until in a short time practically all troops were verminous. Under these conditions, the overcrowding, difficulty of washing and changing of clothing, everything was most favourable for the multiplying and spreading of the pest.

There are three kinds of lice that appear on the body: the clothes or body louse, the head louse, and the crab louse. The body louse lays its eggs, which are called "nits," on the clothes, the head louse lays its eggs in the hair of the head, and the crab louse on the other hairy portions of the body. For our purpose we shall speak of the different kinds as one and the same. The colour of lice varies, and they are generally spoken of as black or grey; it is assumed by some that the colour varies according to the complexion of the individual bearing them.

HABITS OF LICE.—It has been found by experiment and observation that lice have special places for laying eggs, showing preference for the fork of the trousers, the armpits, and the triangles of the tail of the shirt. Other popular places are the shirt seams, neck of the shirt, and the seams of the trousers.

Lice accumulate where there is moisture, heat, and shelter. They live for a period of thirty to forty days, and the female louse generally lays from three to eight times in that period. The eggs hatch out in about a week, and it has been estimated that a female during her lifetime may have a progeny of six thousand. It is thus quite evident that under favourable conditions lice can spread very quickly. Lice feed by sucking human blood, and they may suck for a quarter of an hour at a time. They tend to die out away from the human body, and the longest time they have survived when away from their host and without any food was nine days.

The eggs of the lice are much more resistant than the adult, and that is the reason that often when clothes are disinfected the adults are killed, but the next day and the following days for a week the eggs secluded beneath the folds of clothing hatch out in successive crops. Hence the difficulty in securing complete sterilization. You will now realize that lice live on the blood of man, and that the body and clothing of men are necessary for its existence and reproduction.

Lice do not as a rule wander very far away from their host. But if their home conditions are comfortable, that is, warmth and shelter, they may move about. If several men sleep together, and one is infested with lice and the others free from the pest, it is certain that within a short time all will be "lousy." There does not seem to be much preference shown by lice in choosing their victims, though persons with delicate sensitive skins and those never infested before are more liable to receive the attentions of the pests.

DISSEMINATION OF LICE.—How do the soldiers get lice, and in what places do they get them? If you ask a soldier where he thinks he gets the lice, in nine cases out of ten he will say dirty dug-outs or billets. He will say that he goes into the line or billets clean, and in a day or two gets lousy. It has generally been assumed that the places where lice are found, and from which they spread are: (1) Dug-outs, billets, or bivouacs with the materials in them, as blankets, stoves, and beds; (2) the soldier himself with his clothing and equipment. I may say at once that the great source of infestation is the soldier himself.

Dug-outs, billets, and other living places of themselves are not the great sources of infestation. I have already told you of the eggs upon the clothing developing on successive days and thus spreading the pest. In fact, the most conclusive evidence goes to show that dug-outs of themselves—and the same applies to billets or bivouacs—are not really responsible to any extent for the spread of lice. One observer who has done very valuable work states that after careful examination of five good dug-outs with boarded floors—removing floor in two instances—he did not find a single louse.

All the kits, greatcoats, and equipment were examined at the same time. On another occasion eight dug-outs with floors and tables were examined and no lice found. The dug-outs that are spoken of as being the worst are the large ones. In small dug-outs occupied by officers, N.C.O.s, or men, lousiness is not as common. This is probably because here the opportunities for personal cleanliness are much greater. On account of lice preferring warm material it is very unlikely that they wander on the ground, though on account of being able to live from seven to nine days on the soil, there will be certainly some cases spread by this means. When a dug-out is being vacated by one unit and the kits, beds, and equipment removed, the lice are generally taken along with them. From this evidence it must be assumed

that the dug-outs are not as culpable as it is generally thought. There is no question that lice can be, and are, found sometimes in dug-outs, but these places do not furnish the chief source of the pest.

This observer also found by experiment that blankets and straw are not important agents either in harbouring or in dissemination. The reason given is that the clothing worn next to the skin is warm and forms the natural habitat of lice, and is not likely to be deserted for the colder straw, palliasses, or blankets. It is therefore reasonable to think that the soldier himself is the great source of infestation. That is not so surprising when one realizes that 95 per cent. of all soldiers who have seen six months service are lousy, averaging each twenty lice, and one of the reasons for the spread of the pest is that at the time when men are out of the trenches and supposed to take baths, there are always some who are excused from parade by reason of duty or disinclination, and who have not had their outer clothing disinfected, and thus a certain number of carriers are always present.

These men may infect others either accidentally, when lice may get from the clothing of one person to another in the act of dressing or undressing, or indirectly from blankets or kit. The chief way, however, in which lice spread is from one infected person to another, as when men are compelled to sleep close together for long periods. Here the conditions are most favourable, warmth, the inclination of lice to move in the warmth, and the overcrowding. It has been found that if lice are not killed in the outer clothing they will get into the underclothing within half an hour. The great source of danger is the eggs, and it is necessary to kill them. As eggs hatch out in about a week it is essential that the trousers should be ironed and brushed once a week at the least, so that if all living adult lice are killed, and if the clothing is made free from living eggs every week or ten days, no second generation is developed, and freedom from the pest is secured. The few lice that

may incidentally wander on a person may be disregarded.

PREVENTION AND TREATMENT.—Having said something about the history and habits of lice, it is now most important to take up the question of prevention and treatment. Although so many soldiers are lousy, and although everyone who goes up the line for a tour of duty expects to get lousy, it cannot be too strongly impressed upon you that "lousiness" can to a great extent be prevented.

The preventive measures against lice consist in: (1) Personal cleanliness; (2) clean billets; (3) destruction of lice and eggs on the clothing. With regard to the first of these measures, personal cleanliness, little need be said, since bathing parades are compulsory and medical inspections are frequent. There is very little excuse for anyone being a constant menace to the health of others. These weekly inspections should be held by the Company or Medical Officer, and if carried out properly no man of any unclean habits or lice carriers would escape.

The question of clean billets has already been considered, and it is only necessary to state here that when possible billets or barrack rooms should be fitted with bunks made of wire or canvas stretched on frames. These bunks should be about six inches above the floor, and should also be a foot or more back from the wall at the head of the bed. This will enable the under surface of the bunks to be kept clean. If straw is used, it is preferable to have palliasses than loose straw. All papers, cigarette ends, orange peelings, and refuse of every kind should be placed in sandbags or other proper receptacles; and no dirt or rubbish should be allowed to accumulate in the billet. The floors, walls, skirting boards, woodwork of beds or bunks should be washed with a 5 per cent. solution of cresol, or about 12 oz. to the gallon of water.

DESTRUCTION OF LICE.—We now come to the actual killing of lice and their eggs. If the head is washed

twice a week with kerosene or soap there will be little danger of head lice. Should they be found, however, the best thing to do is to have the hair cut short and treated with kerosene or petrol, or equal parts of kerosene and olive oil, and then well washed with soap and water, or cresol soap. Other articles that may be used are: white precipitate ointment, soap liniment, or a solution of formalin. In very bad cases the "nits" that are protected by a hard substance known as chitin require special treatment. This substance is quite resistant to acids and alkalis, but it is soluble in chloroform or a 10 per cent. solution of acetic acid, either of which can be used, to be followed by kerosene or petrol. The treatment of head lice is very simple as compared with that necessary for the body louse.

DESTRUCTION OF BODY LICE ON THE INDIVIDUAL.— There have been a great many powders and ointments recommended to kill lice and their eggs. Most of these, as you all know, are useless at the Front. There are some, however, that give good results, and I think it is well for you to know them and not waste time at the sacrifice of much comfort in experimenting with or trying some of the useless so-called "sure cures."

If you are lousy and in a position to get clean underclothing but no bath, the best thing to do is to use a powder known as "N.C.I." Pick off all the lice you can, and thus ensure that no more eggs can be deposited. As eggs are generally laid at the fork of the trousers, remove the white patch which binds the seams at the fork. This can be removed without causing any discomfort. Then dust this powder freely on the shirt and breeches. If this is done at night, and you roll your trousers tightly in your blankets, very few lice will be found alive in the morning.

N.C.I. powder is composed of: naphthalene, 96 per cent.; creosote, 2 per cent.; iodoform, 2 per cent. This powder is fatal to lice, and is the best and most successful insecticide in use. One ounce of this

powder per man should be freely dusted on the interior of all clothing once a week. To give you an idea of its efficiency, I will tell you the result of an experiment made by one of the best known workers on this problem. A sleeping bag was made from a blanket, and five hundred live lice were allowed to roam at large in the blanket. N.C.I. powder was then dusted freely over the front and back of the shirt and of the riding breeches as far as the knees. The heroic investigator wore socks, opened up the neck of his shirt and underclothes, making conditions as favourable as possible for lice. In the morning an examination of the clothing and body resulted as follows: The socks gave 155 dead lice, the breeches 30 dead lice, and no lice at all were found on the shirt. The result of this experiment is certainly very gratifying, and all those who use this powder speak of its good results. It can be obtained by your Quartermaster from the S.S.O. The powder should be dusted on the inside of all clothing once a week. This will be found quite sufficient.

There is one point to be mentioned about this powder. It is an irritant if used too freely at the fork of the trousers. For that reason it is usual, where possible, to associate with this powder the use of an ointment as an insecticide for this part of the trousers. The best of all the ointments is vermijelli, and it should be rubbed over the body from the neck to the knees. If used locally the lice will migrate to other places. As I have just said, the most effective is a combination of N.C.I. and vermijelli, the ointment smeared at the fork of the trousers and the powder dusted on the shirt and trousers. Vermijelli is composed of: crude mineral oil, 9 parts; soft soap, 5 parts; water, 1 part. One ounce of this ointment is sufficient for one week to smear on the fork of the trousers and along the seams. The action of this grease is to smother the young lice as they hatch from their eggs.

There are many other preparations which have been

tried and found unsatisfactory for use in the Field, as Oxford grease, and various powders and sulphur. With ordinary care the combination of "N.C.I." and vermijelli will keep men comparatively free from lice. In the trenches or billets an effective way of destroying the eggs of lice is by the use of a piece of hot metal or a tinder lighter along the seams of the clothing. There are several other methods that might be employed to kill lice and their eggs when men are in billets behind the line. If shirts are boiled for five minutes the lice and eggs are killed. If soaked thoroughly in $1\frac{1}{2}$ per cent. solution of cold cresol all lice are killed at the end of one hour. This is a very convenient method that can be employed under most circumstances other than being in the line as cresol is always available. A 7 per cent. cold solution of chloride of lime will kill lice on clothing at the end of twenty-four hours. Hot irons are of much service for killing both lice and their eggs, and are especially valuable in dealing with such articles as leather breeches on account of the leather getting damaged if disinfected by steam.

DIVISIONAL BATHS.—On a large scale lousy clothing is treated at divisional baths. These baths have developed into a great success, and good bath houses are now found in every divisional area. The object of these baths is to deal with a large body of men in a short time, to enable them to have a bath, get a clean suit of underclothing, and have their outer garments disinfected. Bathing arrangements are made by the Divisions, and usually a divisional bath officer is appointed, who is responsible that all garments are washed and disinfected. These divisional baths can be very quickly installed in areas, and are very satisfactory. There is never any trouble about getting a bath and clean underclothing, but often there is difficulty in having outer garments disinfected. The ordinary disinfecting apparatus is limited in capacity, and too often men are issued with clean underclothing only to become infected within

one half-hour from dirty outer clothing. The methods employed at divisional baths for killing lice and eggs are for the most part either steam or dry heat. Several different types of "plants" have been devised, in some of which dry heat has been used, and in others steam. The most satisfactory and successful method at present in use is the dry method of disinfestation, introduced by Major Orr, C.A.M.C., when sanitary officer at Shorncliffe. It consists of a hot air chamber constructed of corrugated iron with a ventilator at the top, and a door for putting in and removing the clothing. The fire is applied from below, and coke, coal, or wood may be used. It is simple, efficient, time-saving, and economical. It is much to be preferred to the moist heat method, and renders the use of powder and grease—which are often objectionable—largely unnecessary. The scheme has been adopted by the Canadian Corps in France, where it is employed in connexion with all the baths. The dry heat method has the advantage also of not affecting articles that may be destroyed by steam, as breeches, belts, &c. In some Divisions the moist heat method is employed either by means of a Foden lorry "Thresh," or by means of a large jacketed chamber. Where a "Thresh" is used the garments not too tightly packed are given half an hour at a temperature of 220° F., and a pressure of 5 lb. per square inch. The "Thresh" has room for sixty blankets or twelve kits at one working. On this basis it is estimated that at least eight would be required per Division, and as there is only one Foden allowed per Division, it is evident that the necessary disinfestation could not be carried out properly by this means.

Another scheme adopted in some divisional areas in conjunction with the "Thresh" consists in having the seams of the outer clothing ironed with a hot iron which instantly kills lice and their eggs. It takes about fifteen minutes to go over the clothing, and the work of a Division would require fifty permanent ironers. This scheme rarely works out in practice.

LECTURE VI

Infectious Diseases and Disinfection

Infectious diseases are those diseases that may be communicated from one individual to another, whether by direct or indirect contact, such as diphtheria, measles, small-pox. They are caused by germs, and I have already explained how the germs may pass from one person to another through the air, water, food, soil, or clothing. For all practical purposes there is no difference between infectious and contagious diseases, though the former is the term usually employed. Sometimes the distinction is made as to whether there is direct contact between the patient and the person exposed; if so the word "contagious" is used, and if no direct contact, the word "infectious."

Another term frequently used when speaking of infectious disease is "incubation." This is the time that elapses between the entrance into the body of the germs causing the disease and the first manifestation of illness. It is the "hatching" period during which nothing can be observed. Quarantine is the period during which a person having been exposed to a disease must be segregated. The different periods of quarantine for different diseases depend on the differences in the incubation periods for those diseases.

An outbreak of infectious disease is one of the gravest calamities that can occur in a camp. The duty of medical officers is to keep the efficiency of the fighting forces at the highest point. In fixed camps, at the base, or on the lines of communication, the question of infectious diseases is not so serious or so important as with fighting battalions in the line. The organization of a campaign for combating the spread of infectious diseases calls for great resourcefulness, energy, and ability on the part of the medical officers.

It is a very serious matter to recommend the quarantining of a company or whole battalion that is due for a tour in the trenches. The question will, of course, largely depend upon the military situation, and while perhaps the preventive measures cannot be adopted to the same extent as in civil life, yet a great deal can be accomplished. If a number of cases of infectious disease occur in one company, it is quite often possible in so-called "peace times" to keep that company out of the line in quarantine.

The principal infectious diseases met with in this country are measles, mumps, diphtheria, scarlet fever, cerebrospinal meningitis, and small-pox. The following are fairly common in other theatres of the war: Typhus, relapsing fever, dysentery, cholera, malaria, and plague. What should be done when a case of infectious disease develops? The first thing is to prevent its spread to others, and then determine how, and why, it has occurred.

The following general measures can be adopted in dealing with any infectious diseases immediately a case develops in a camp:—

(1) Notification; (2) removal of infected; (3) isolation of contacts; (4) disinfection; (5) preventive measures. The notification should be made at once to the proper authority, and the infected person immediately removed to a special hospital set apart for infectious diseases. Early notification is absolutely necessary in order to get quick results, to enable preventive measures to be instituted, and to determine the origin of the disease.

While awaiting removal the person should be kept separate from all others. The next thing is to isolate the "contacts," that is, those who have been exposed to the same infection. Sometimes it is not necessary to isolate all contacts, and it is sufficient to have them inspected every day for the ordinary quarantine period. This is done with regard to the less serious of the infectious diseases as mumps and measles. The contacts of the following should always be isolated:

small-pox, diphtheria, scarlet fever, cerebrospinal meningitis, typhus and relapsing fever, cholera, plague, yellow fever.

MEASLES AND MUMPS.—The contacts of measles and mumps should be inspected for sixteen and twenty-four days respectively.

SMALL-POX.—All contacts of small-pox should be immediately vaccinated if not successfully done within two years. They should be isolated and medically inspected every day for eleven days after a successful vaccination, or eighteen days after exposure if there is any question as to the success of the vaccination. There should also be frequent examinations of all men in the camp, in addition to the contacts, and any cases with a rash at once isolated.

A case of small-pox occurred in this Division last year. The medical authorities were at once communicated with, and the patient was removed to an infectious disease hospital. The whole company to which he belonged was quarantined for sixteen days. All the men in the company were vaccinated, as there was some difficulty in determining who had, and who had not, been successfully vaccinated within two years. These men were kept by themselves, not allowed to go to *estaminets* or such places, and were not permitted in any way to come in contact with others.

The billet occupied by the case was thoroughly disinfected, as well as any clothing left behind. The men in this particular unit were able to carry on their work without coming into contact with any one else. They were carefully examined every day by their medical officer for a period of sixteen days. These precautions proved effective, and not another case occurred.

SCARLET FEVER.—With regard to scarlet fever all contacts should be inspected for ten days, and if there should be an epidemic all cases of sore throat should be looked upon as suspicious and isolated for three days.

DIPHTHERIA AND CEREBROSPINAL MENINGITIS.—The contacts of a case of diphtheria should be at once isolated. The germs of the disease are found in the nose and throat, and they can very easily be discovered by bacteriological examination. It is usual to have three negative results before releasing the contacts. Exactly the same procedure is adopted with cerebrospinal meningitis. Contacts of the infectious diseases should be isolated in well-ventilated huts or barracks. There should never be any overcrowding, and the greatest possible amount of fresh air available should be obtained. This particularly applies in the case of cerebrospinal meningitis.

It has been noticed that this disease is very prone to spread when an outbreak occurs in barracks. There is not nearly so much danger if men are living in tents or bivouacs. Although the tents may be wet, damp, and uncomfortable, there seems to be better and fresher air with much less liability to contract the disease. The most thorough disinfection should be done when dealing with cerebrospinal meningitis. Any personal equipment and bedding left behind should always be burned. The billet or tent occupied by the case must also be carefully disinfected.

TYPHUS AND RELAPSING FEVER.—These diseases are not likely to be seen on this Front, though it is well to be prepared to take immediate action. As you remember, they are spread by lice, so that the first thing to be done is to free patients from all lice and isolate them for fourteen days. The contacts should be inspected by the medical officer every morning and evening. A special campaign for the destruction of lice should be inaugurated.

PLAGUE.—This disease is spread by fleas, and, like typhus and relapsing fever, is associated with dirty surroundings and the presence of fleas and lice. The obvious preventive measures are absolute cleanliness and the destruction of lice and fleas. Plague is spread by fleas which have fed on plague-stricken rats. In countries where plague is common, as in the Eastern

theatre of war, every effort is made to render barracks rat-proof. All contacts of these diseases should be isolated for ten days. In times of epidemic the population should receive a protective inoculation against plague. A vaccine has been in use for some years and gives good results.

TYPHOID, PARATYPHOID, DYSENTERY, AND CHOLERA.—It is hardly necessary to say anything about these diseases, as I have so often indicated the lines on which preventive measures are carried out. But let me again point the danger that arises from "carriers." About 3 per cent. of all persons who have had typhoid continue to pass the germs in the discharges from the bowels and bladder after they have recovered. It is therefore necessary that those in a unit who have had these diseases should be at once examined bacteriologically whenever a case occurs. The immediate friends and those sleeping near or opposite the infected person should also be considered as possible carriers. Protective inoculation gives the most wonderful results in preventing the spread of typhoid and paratyphoid.

You are familiar with the channels of infection. You know that these diseases are spread by infected water and food through the agencies of flies and dirt. You know that such vegetables as lettuce or water-cress washed or watered with contaminated water may give rise to them. You know that cooks or mess orderlies may contaminate the food. You know that the bedding, blankets, and clothing of carriers may spread these diseases, and, of course, you all know that alternating as they do between latrines and mess rooms they are often the causative agents.

The precautions, then, are to ensure a pure supply of drinking water, protection of all food supplies, and the proper disposal of all waste products. Severe epidemics of typhoid, paratyphoid, and dysentery are nearly always due to contaminated water. Small outbreaks as well as individual cases are often due to infected food. Quite a number of cases of paratyphoid

and typhoid fever occurred during some recent very heavy fighting, and it is quite possible that these cases were due to contaminated food. In this fighting where advances were being made there was no latrine accommodation. In the shelled area old latrines had disappeared, and it was impossible to provide new ones; the consequence was that men used trenches and shell holes and could not easily cover their excreta. As a result large areas of ground were fouled, and the clothing and boots of men must have conveyed into the dug-outs the germs of disease.

As men on arriving in their dug-outs were often wet or tired they frequently eat food without washing their hands, and in this way contracted disease. The scarcity of water often makes it difficult to secure enough for ablution purposes during fighting periods. It is no use to say that in these cases men should do this or that. The most we can hope for is that they do the best they can.

MALARIA AND YELLOW FEVER.—A word is necessary about diseases that are caused by mosquitoes. The preventive measures include the removal of breeding places by good drainage, the isolation of infected persons in mosquito-proof rooms, filling in pools or ponds of stagnant water that cannot be drained, covering all cisterns, oiling large bodies of water, and the protection of barracks and buildings by making doors and windows mosquito-proof.

After a case of infectious disease has occurred, and the patient has been properly dealt with, the next thing to do is to determine the cause. It may be found that the water supply is bad, in which event there will be many cases. If the water is at fault a new source of supply must be provided. There may be a "carrier" in the kitchen, and his removal is sufficient. The milk or other foods may be contaminated; perhaps fruit or vegetables eaten raw may be the source of infection. All these possible sources should be thoroughly looked into, and in most cases the cause can be found.

VENEREAL DISEASES.—A good many soldiers are lost to the fighting forces by these diseases, and every attempt is being made by the Army to reduce the number of cases. Under the heading "Venereal Diseases" are included syphilis and gonorrhœa. They are caused by germs, and if neglected and not treated in time they are bound to lead to serious consequences.

These diseases are usually contracted by sexual intercourse, but some cases may be caused accidentally. A case of syphilis may be caused if one soldier smokes the pipe of a friend who has the disease. Gonorrhœa may be contracted from infected water-closets; some men say they get the disease in this way. The infection may be found in large public latrines. In any of the cities where there are a good many of these cases the latrines necessarily get infected at times. The germs get on the hands of men who are diseased, and from there to the towel in the public latrines, and another individual may, and often does, get the germs from the towel on his face and into the eyes, thereby causing very serious inflammation.

These cases not only render a man unfit for longer or shorter periods of time and of no service to his country in time of need; but they may also very greatly impair the state of his health. Gonorrhœa, for example, may lead to disease of the heart valves, bladder, kidney, and a very serious type of rheumatism. Syphilis often gives rise to disease of the bones, the internal organs, the muscles, and the brain.

I do not think it is sufficiently realized how difficult these cases of venereal disease are to cure, and how long a time it takes even with the best of treatment. Their effects are very far-reaching, and it is only necessary to visit any large public institution to see how many of the occupants can trace their presence there to one or both of these diseases. It is a most tragic sight at any special hospital for children to mark the large number of little ones who have been made blind for life through gonorrhœa. Another important

thing to remember is that if a man marries before he is properly cured of these diseases he is liable to communicate them to his wife and in certain cases to his children.

How can they be prevented? The only way is: (1) To avoid the cause; (2) to be careful when using any public sanitary conveniences.

Another point I wish to impress upon you is that, if you should by chance contract either of these diseases, you should report at once to your medical officer. Do not attempt to hide or conceal it; you know there is a very severe penalty in the Army for concealment of these diseases, and when found out a man will be punished for it. Do not try to treat yourself, or do not think that by using some of the very many so-called cures or preventives that you will get over it quickly. It is a great mistake.

The only way to get quick results is to parade at once before your medical officer and get the proper treatment. To try and conceal the disease is a mean thing to do. It is not playing the game, and is not fair to the comrade who stands by your side. There is great danger of conveying the disease to others, and if you try to carry on you are almost sure to be the means of spreading the disease. For your own sake and for the sake of your comrades report at once to the proper authorities.

I might give you a list of the incubation and segregation periods of the different infectious diseases in case any of you want to make a note of them:—

Disease	Incubation period	Quarantine period
Small-pox	10 -- 19 days	20 days
Chicken-pox	10 -- 16 "	20 "
Scarlet fever	1 -- 4 "	10 "
Measles	10 -- 14 "	21 "
Typhus	5 -- 14 "	15 "
Enteric	10 -- 14 "	23 "
Plague	2 -- 8 "	21 "
Cholera	3 -- 6 "	12 "
Diphtheria	2 -- 10 "	12 "
Mumps	10 -- 20 "	24 "
Relapsing fever	2 -- 8 "	14 "

CONTROL OF INFECTIOUS DISEASES IN THE CIVIL POPULATION.—If you should happen at any time to notice a case of infectious disease in civilian houses, it is your duty to notify at once your medical officer or the Town Major. The Town Major then immediately puts the house "out of bounds" to all troops until disinfected and all preventive measures have been taken.

Arrangements have also been made with *maires* of villages and French civilian doctors that they notify the Town Major of all cases of infectious diseases occurring in the civil population. The Town Major informs the sanitary officer of the area, who investigates the case, and is responsible that all troops billeted there are removed, that proper quarantine be maintained, and efficient disinfection measures employed.

Medical officers must assist the French authorities as much as possible in preventing the spread of infectious diseases, and in such cases as typhoid and paratyphoid must inoculate all civilian contacts.

DISINFECTION.—In speaking of infectious diseases I frequently mentioned disinfection as being necessary in their prevention. If germs are the cause of disease, and we know they are, and if these germs come away in the discharges of the body, in the breath, and from the skin, and I have shown you that such is the case, then it is necessary when dealing with diseases that we should do everything possible to kill these germs and prevent them from getting into the bodies of others and thus set up disease.

What is a disinfectant? A disinfectant is an agent that will destroy infection, that is, the germs that cause disease. An antiseptic, on the other hand, is an agent that will hinder the growth and development of germs, impairing their vitality, but does not necessarily kill them. A deodorant is a substance that will remove a bad smell.

Disinfectants are divided into: (1) Physical; (2) chemical. Physical disinfectants are fire, heat, sun-

light, and fresh air. Chemical disinfectants may be solid, liquid, or gaseous.

Fresh air and sunlight are the best disinfectants; and the air in a room is disinfected by opening doors and windows, and admitting fresh air and sunlight. If the day is warm and the sun powerful, germs in the air and on the tables, walls, chairs, &c., are killed by the direct rays of the sun. Fire is the best and most efficient of all disinfectants, but it can only be employed for the destruction of articles of no material value. When articles of clothing badly infected are being burned a complete destruction of these articles must take place, and care must be taken that no particles are scattered about by the wind.

DISINFECTATION BY HEAT.—Articles may be disinfected by boiling or by dry or moist heat. Boiling is a simple and efficient method of disinfecting linen, cotton, metallic, or earthenware articles. Woollen and leather articles should never be boiled. Boiling should be continued for at least fifteen minutes. Moist heat is one of the most valuable means at our disposal for disinfecting. And as you know special disinfectors like the "Thresh" are provided for each Division. All tunics, trousers, and greatcoats, articles of cotton and wool are best disinfected by moist heat under pressure. The temperature may be as high as 235° or 240° F., and articles should be subject to this temperature for half an hour. There is an arrangement in these disinfectors whereby the articles are dried before being taken out, which is of great advantage, as if removed while wet or damp they are liable to shrink and be damaged. Steam may be employed as current steam where there is simply the temperature of boiling water 100° Centigrade or 212° Fahrenheit. This temperature may with good effect be raised five or ten degrees by adding a salt like calcium chloride to the water.

An important thing to remember when using the portable "Thresh," or Foden lorry Thresh disinfectant, is that articles of clothes should not be packed too tightly

or rolled into bundles. If that is done the steam cannot penetrate properly, and poor results are obtained. You often hear complaints about clothing coming back from the disinfectant with lice still to be found. That condition almost invariably results from either close packing of the clothes or too short exposure to the steam. Not more than a hundred articles of underclothing or thirty-five blankets should be put into a disinfectant at one time, and they should be left in at least forty minutes. (See fig. 56.) There is a splendid form of disinfectant made, though not seen up here, that can give either dry or moist heat. This dry heat is the best method of dealing with leather goods, furs, and pictures, that may be ruined by steam heat.

CHEMICAL DISINFECTANTS.—I now come to chemical disinfectants which may be either gaseous or liquid, and these are very much used in military and civil life. The chief gaseous disinfectants are sulphur fumes, formaldehyde, and chlorine. Of these sulphur is the one most frequently employed. These gases are, as generally employed, not so effective as either steam or liquid disinfection. It is difficult for the gases to penetrate garments, and the disinfection is often largely on the surfaces alone. The sulphur is placed on a metal dish that in turn is supported over a pail of water to prevent any danger of fire. The sulphur may be covered with oil or alcohol to make it burn better. The quantity of sulphur used depends upon the size of the room, and it is usual to have 3 lb. for every thousand cubic feet of air space. The room where sulphur vapour is being used should be made air tight by covering up all the windows, crevices in the walls or floors, ventilators, fireplaces, and doors. Every opening through which the gas might escape must be carefully closed over with strips of paper applied by means of paste made from flour and water. Sulphur vapour only acts in the presence of moisture, and that is generally procured from the walls already wet as a result of the liquids employed in washing,

or some water may be boiled to procure vapour. The room should be kept tightly closed for ten hours. This is the procedure to be adopted in fumigating a room with sulphur, chlorine gas, or formaldehyde.

Where chlorine is used it is produced by the action of hydrochloric, or muriatic, acid on chloride of lime in the proportion of a pint of acid to the pound of lime. It is very irritating to the eyes, nose, and lungs, as many of you know from bitter experience, and is now seldom employed. It is, however, most effective.

CLAYTON MACHINE.—A satisfactory method of disinfecting with sulphur is by means of the Clayton apparatus, an electric machine that quickly burns up the sulphur. The gas is delivered into an air-tight hut, room, or cellar, made tight by pasting paper over the cracks and crevices. A convenient size of room or hut to use is one 20 ft. by 15 ft. by 10 ft., thus giving a cubic capacity of 3,000 ft. In a hut of this size six hundred blankets can be treated for lice and their eggs in three hours. The blankets should be hung on lines 1 ft. apart and at least 1 ft. from the ground. Clayton disinfectors give good results at rest stations, operated and run by field ambulances where there are many blankets to be disinfected.

FORMALDEHYDE VAPOUR.—This may be produced by heating the formalin in a copper boiler, and allowing the gas to flow into a room by means of a tube placed in the keyhole. A convenient way of generating formaldehyde gas is from potassium permanganate and formalin, 1 lb. of the crystals to one pint of formalin for every thousand cubic feet of air space. The room is prepared for disinfection, and the crystals of permanganate of potash are put in a metal receptacle or tin pail, and the pail is placed in a large tub to prevent any of the froth from overflowing. Formalin is poured on the permanganate, and the room is closed as rapidly as possible by sealing up the door from the outside. This gas also is very irritating. The ordinary box respirator or "P.H."

helmet may be used when entering or leaving the room and gives complete protection.

These gaseous disinfectants are very readily applied and can generally be easily obtained. They are not as valuable as liquid disinfectants, and they are really only to be depended upon for surface disinfection. Sulphur is probably the most powerful; it is cheap, and can be obtained in almost every small shop. It is especially effective in disinfecting ships, and will kill rats if sufficiently concentrated. Formalin is also very easily applied, but not so powerful as the other two.

SERBIAN BARREL.—The Serbian Barrel is a popular and efficient method of disinfecting on a small scale. It consists of an ordinary sized barrel of about sixty gallons capacity with the bottom perforated, and a flat lid covered with blankets or cloths, and well weighted down. The barrel is placed over a boiler of some kind, metal preferably, and the junction of the boiler with the tank should be covered with baked mud or bricks so as to prevent any steam from escaping. Fire underneath the boiler should be very strong and vigorous to fill the barrel with steam in a little over half a minute. The capacity of the barrel is seven blankets, and they are completely disinfected at the end of one half-hour's exposure to current steam, when both lice and eggs are killed. It is a simple arrangement that does not require much fuel, and can easily be improvised in the field.

LIQUID DISINFECTANTS.—The principal liquid disinfectants are cresol, formalin, chloride of lime, carbolic acid, bichloride of mercury. Liquid disinfectants are very powerful, and when steam is not available they may be used for articles of clothing. Cresol is very well adapted for wood and iron, and is invariably employed in disinfecting rooms. Carbolic acid is also very effective for the same purpose; it dissolves the grease that may be on woodwork, and thus kills the germs; it has no tarnishing effect on metals. These liquids may be used with a spray for disinfecting walls and ceilings. A very good sprayer is

the MacKenzie, and a gallon of disinfectant solution should be sufficient for 400 square feet. A very powerful disinfectant much used in civilian life, but rarely used here, is bichloride of mercury in the proportion of 1—1,000. It has no advantages over cresol or carbolic acid, but has the disadvantage of frequently causing poisoning on account of having no odour or colour. To prevent this a solution is always prepared with a colouring agent like aniline blue.

DISINFECTATION OF A ROOM.—To give you an idea how disinfection is carried out more or less in detail, I shall consider a case of scarlet fever. The patient is removed, and leaves all surplus clothing behind. The object is to disinfect the clothing and bedding in the room occupied and the discharges that may have been left.

The first thing to do is to burn whatever is of little or no value, such as old clothes, papers, books. Everything in the room must be disinfected. This includes clothing of various kinds, tables, chairs, woodwork, books, and leather articles.

If there is a disinfecting station close at hand all clothing, materials, mattresses, &c., should be wrapped up in sheets, sprinkled with cresol, and removed to the disinfector. If there is no disinfector available, resort must be had to other methods. Cotton sheets, linen goods, such as sheets, pillow-cases, and woollen articles, should be boiled for half an hour or soaked in cresol solution—4½ oz. to the gallon—for a period of not less than two hours; if that time is not available, a strength of 12 oz. to the gallon for a period of half an hour should be used. Mattresses, pillows, uniforms, or ordinary clothes can be disinfected by spraying thoroughly with formalin, 8 oz. to the gallon of water. Books, furs, and leather goods, when no dry heat disinfection can be employed, should be suspended on lines drawn across the room and subject to the action of formaldehyde. Riding breeches and strappings can be disinfected by hot ironing.

When flannel or woollen articles of clothing are to receive damp disinfection, it must be remembered that these articles are ruined if the water is too hot. The temperature should not exceed 95° Fahrenheit or 35° Centigrade, as otherwise there will be very serious shrinkage. In washing woollen articles lukewarm water should be made use of, never boiling or very hot water. Washing soda is not advisable; the issue of yellow soap only should be used. Grease and perspiration can be removed by adding a little ammonia in the proportion of one tablespoonful to two gallons of water. Articles may then be rinsed in clear tepid water, wrung and well pulled out before drying.

This disposes of the clothing. The next materials are chairs, tables, woodwork. They are easily disinfected by washing them carefully with a solution of cresol, 8 oz. to the gallon of water. Ceilings are difficult to do; sometimes they can be sprayed with formalin in the same proportions. In washing rooms the greatest care must be taken to see that all corners, cracks in the skirting boards or walls get a good soaking with the disinfecting solution, as it is in these dark, inaccessible places that germs are sure to be found. In disinfecting a house, such articles as door-knobs, railings, or staircases, and all objects that are frequently handled should be given special attention. When this work has been accomplished there are very few articles left in an ordinary room that require disinfection. There may be some books, furs, and leather, and these can all be subjected to formaldehyde gas. Strings are drawn across the room, and all such articles are hung on them, books with the pages well open.

The room is then sealed up as tightly as possible. It is essential that this be done very carefully, as, in order to get good results, the gas must be as concentrated as possible. The windows, doors, fireplaces, and ventilators are all well sealed up and the gas produced in the way described. The room is left for

eight hours before being opened, when all the articles should be taken out and well aired in the sun. The doors and windows should also be thrown open, allowing the sun and air to penetrate. It is very easy to disinfect an ordinary barracks, as there are few articles in them compared with a house. Liquid disinfection is the best method. It is always well in disinfecting such places to lime or whitewash all woodwork.

DISCHARGES FROM INFECTED PERSONS.—These discharges are best disinfected by liquids; an equal amount of cresol or carbolic acid in proportion to the bulk of the excreta or urine should be applied of a strength of 5 per cent. When a case of typhoid exists the greatest care should be taken to disinfect urine in this way. If these solutions are not available—though it is hard to imagine such a condition—they may be treated with boiling water. Any discharges from the mouth, nose, or throat may be treated by a solution of one of these disinfectants.

This finishes the most important part of disinfection; but the disinfection of the hands, which is also done by using any one of these solutions; and finally washed with warm water should not be forgotten. If possible, a nail-brush should be employed. I cannot too strongly impress upon the sanitary personnel, those actually employed in sanitary work, the urgent necessity of disinfecting their hands before meals. There is no question that germs are frequently conveyed to food from soiled hands, and this could be very easily prevented if the hands were always carefully washed before eating.

The preparation of these disinfectants is as follows: carbolic acid, 5 per cent. solution or 8 oz. to the gallon; formalin, 5 per cent. or 8 oz. to the gallon; cresol, 5 per cent. or 8 oz. to the gallon. For special purposes, such as spraying manure, cresol should be used in the strength of 12 oz. to the gallon. Bichloride of mercury, 1—1,000 solution, is made by dissolving 1 oz. in three gallons of water, adding 1 oz. of strong hydrochloride acid, coloured with aniline blue or fuchsin.

TRENCH FOOT.

I have been asked in giving this series of lectures to impress upon you the necessity of taking all measures to prevent the affection known as trench foot.

What is trench foot? It is a condition produced by (1) prolonged standing in cold water and mud; (2) the long-continued wearing of wet socks, putties, and boots. Trench foot is hastened by wearing tight boots, putties, or socks, or anything that has a tendency to cause constriction of the lower limbs.

What does it look like? Most of you are familiar with the appearance which is suggestive of chilblains. At first there is a tingling sensation of the legs, followed by pain. As the condition progresses there is a swelling of the feet with diminished sensation. In some marked cases there is a cyanosis, that is, a blackening of the skin with increased swelling, and the formation of blebs. If no treatment is given the condition becomes much more serious, and a dry gangrene, the death of the tissues, develops, leading perhaps to the loss of large amounts of skin, of one or several toes, or in very severe cases to a portion of the lower limb.

What really happens is, that by long-continued contact with cold water the tissues absorb a certain amount of water, just as a cloth does. The result is that these tissues getting filled with water the circulation of the blood is interfered with, and as a consequence after some time portions of the skin die from want of nourishment brought to them by the blood.

In the olden days this condition was known as frost-bite, and was the cause of heavy loss during the Crimean war. It is not necessary to have great cold or even frost to produce trench foot; it is the standing for long periods of time in waterlogged trenches that brings about the condition. From a medical standpoint it is so important that every case must be

specially reported upon, giving all details as to the time spent in the trenches, the amount of water in them, and what precautions were adopted. The importance of trench foot could not perhaps be more impressed upon you than by the fact that the Division will cut down, or discontinue, the leave allotment of units showing a high percentage of cases. The reason for this is that the condition can be prevented by carrying out the proper treatment laid down.

WHAT IS THE TREATMENT?—(1) Trench foot can be prevented by making the trenches as dry as possible. This is an engineers' problem that can be, and has been, solved. Soak pits may be constructed under the bath mats or saps, where the water may run off from the trenches into deep soak pits.

(2) Waterlogged trenches should be held by as few men as the military situation permits, and for short periods.

(3) By the provision of hot drinks of coffee, tea, or rum at frequent intervals.

(4) By as much movement as possible while in the trenches. Hot drinks and moving have the effect of maintaining good circulation, which is essential.

(5) By ensuring that the men go into the trenches with dry socks, boots, putties, with legs well rubbed with whale oil or anti-frostbite grease, and with an extra pair of socks.

(6) By the provision of dry clothes and socks on coming out of the trenches.

These are the preventive measures that should be adopted. The exact detailed method of coping with the condition is as follows: Before a battalion goes into the line the company officer or platoon commander should see that all men have their feet washed and dried. Then each man rubs anti-frostbite grease or whale oil well into the skin. It is not sufficient merely to rub it in lightly. It must be rubbed in thoroughly until the skin is dry. The oil or grease is applied for the same reason that you rub dubbin into boots to keep out the wet, namely, to keep the water from

getting into the tissues of the legs. When that is completed clean dry socks are put on and also dry boots, and men going up the line are given when possible long gum boots. When these boots are provided care should be taken to have the socks pinned to the trousers to prevent them from working down under the heel. Garters must not be worn.

The men are now ready for the trenches, and they should carry with them two pairs of socks, one pair on their feet and one pair in their pack. The following morning they take off their wet pair and put on the dry. This is done up the line. Down at the transport lines the Quartermaster or Q.M. serjeant draws as many pairs of clean dry socks as he may require from the baths officer. In the evening when the rations are sent up a clean pair of socks is also sent up for each man and the wet pair brought back, thus ensuring a clean dry change every day. Then at every opportunity, and it can often be arranged every other day, the men should wash and dry their feet and rub in oil or grease when in the support line and have their feet inspected by N.C.O.s. This procedure should be carried out when the battalion is in the line.

When the battalion comes out into reserve a special inspection of the men's feet should be made by the medical officer. This is very important, and much good can be accomplished by such regular inspections. Many men are lost to their battalions for long periods on account of feet affection. It is stated that in the Franco-Prussian war 30,000 men were incapacitated on account of sore feet.

TREATMENT OF TRENCH FEET BY THE FRENCH.—A good deal of success has attended the treatment adopted by the French medical officers. The feet are very thoroughly washed with a soap comprised of soft potash soap, 1,000 parts; powdered sodium borate (borax), 100 parts. After this warm whale oil is well rubbed into them, and the feet are dusted with a powder of talc, 100 parts; powdered camphor, 25 parts. About a teaspoonful of the powder is dusted

over each foot. After coming out of the trenches the same procedure is adopted.

If the feet are tender they may be treated with a solution of formalin, two teaspoonfuls to the pint of water; they may be hardened by a solution of alcohol and water or by a 2 per cent. solution of salicylic acid. Chafing of the heel on account of the friction between the sock and the foot may be prevented by soaping the inside of the sock, so that when the foot gets hot and begins to sweat, the lather formed by the soap acts as a lubricant. When the weather is cold and there is no sweat, a powder of boracic acid, salicylic acid, and talcum may be employed. Another painful condition often met with is blistered heels. These blisters should be opened and painted with iodine, then some absorbent cotton put on and held in place by adhesive plaster.

CORNS.—Hard corns should be carefully pared and the core removed by painting for a few days with salicylic paint, which is probably the most effective application. Soft corns between the toes may be treated by dusting with boracic or zinc powder and some absorbent cotton placed to absorb the moisture. Ingrowing toe nails sometimes give trouble. They are prevented by cutting the nails square and keeping them properly trimmed. If the nail is growing into the flesh, it can often be made to grow straight by inserting a small bit of absorbent cotton under it. These are simple rules which, if properly attended to, will reduce very greatly the number of men rendered inefficient by feet trouble.

LECTURE VII

Duties of Sanitary Personnel

It might not be amiss to review briefly the duties of those responsible for the sanitation of camps, billets, and areas.

FRONT LINE AREA.—In the front line area latrines should be visited once every day, cleaned, and repairs made if necessary. If pails are in use, they should be emptied twice daily, just after dawn and before dark, the greatest care being taken to cover the excreta with earth.

The sandbags containing refuse should be collected from in front of the dug-outs, from the kitchens and trenches, and the contents brought to a refuse dump and buried. These refuse and excreta dumps should be placed in shell holes or pits as far away as possible from kitchens and dug-outs.

The men occupying dug-outs are responsible for their cleanliness and sanitary condition; all refuse to be removed is placed in sandbags at the entrance to the dug-out, and then is taken away by the sanitary fatigue men. They should systematically go over the trenches with empty sandbags for any rubbish or odds and ends that may have been thrown on the bottom of the trench. There should be at least four men per platoon detailed for sanitary work in the trenches, and this number can be supplemented at any time when necessary.

These men should be kept permanently at work, and should not be asked to do guard or sentry duty. Only in emergencies or on special occasions should they be asked to perform any other work. If the sanitation of the front area is to be properly looked after, men who have had instructions in sanitation should be permanently detailed for this work and nothing else.

The long communicating trenches leading from the

main road to the support lines should also be carefully gone over for refuse, and the latrines inspected daily. It is necessary to have latrines not only in camps behind the lines but also along all public roads, paths, and sunken roads leading towards the front line area. If this is not done there is sure to be a great deal of ground pollution in the approaches to the front line.

The chlorination of water should be attended to by the medical personnel attached to battalions. It is usual to have one man at the transport lines and the others in the trenches. It makes no difference where the water comes from—standpipes, tanks, or water-cart; the water details under instructions from their medical officer must see that it is invariably chlorinated.

The duties of water details in units are the same wherever they are, or whatever their situation, in the trenches, camps, billets, or on the march. They should never be employed on any other duties, and if they are detailed for other work should at once report to their medical officer. Sometimes it may be necessary to disinfect dug-outs, and this is also done by sanitary men supervised by the medical officer.

DUTIES OF SANITARY PERSONNEL IN CAMPS.—Where men are placed in huts or tents in camps away from villages good sanitation is easily effected. Latrines should be washed with cresol solution every morning, and in warm weather the surroundings and urinals should also be sprayed with 5 per cent. cresol to keep flies away. The latrines should always be kept "fly-proof," and battalion pioneers asked to make any repairs, such as replacing hinges and lids. All refuse should be daily burned in the camp incinerator, which must be provided. Burnt tins should not be allowed to accumulate near the incinerator, but buried daily in disused trenches, or placed in soakage pits on roads or walks.

All huts and tents should be swept, cleaned, ventilated, and refuse removed to the incinerators. Suitable receptacles, fly-proof and watertight preferably,

or sandbags should be placed near every row of tents or huts for the reception of all refuse. Ablution tables should be washed daily, and kept clean and tidy. Especial care should be taken to keep kitchens and their surroundings clean. All liquid and dry refuse must be removed twice daily. All woodwork, food-safes, and refuse receptacles should be kept lime-washed and clean. The transport lines should also be kept scrupulously clean. All manure should be removed daily to the dump and close packed. The standings should be lime-washed, and the usual care taken of latrines. In addition to this the whole area within the camp lines should be carefully searched for any refuse, such as papers, tins, clothes. Grease traps and soakage pits should be daily examined, cleaned, and changed when necessary. For military reasons, to escape bombing and in order to be screened from enemy aeroplanes, camps are frequently placed in woods or forests. Such camps are exceedingly difficult to keep clean, and men will persist in throwing refuse behind trees, in trenches, or in old dug-outs. They will also wander into the woods and foul the ground rather than go to the latrine. They will even do this in preference, though latrines may be quite near and convenient. To prevent this practice latrines and urinals should be placed close to huts and tents. The strictest discipline must be enforced, and men punished who are found committing a nuisance.

Very often it may be necessary to put woods outside the camp area "out of bounds," or have the wood patrolled by sentries during the day and until the bugle sounds "lights out." Camps in the forward area are generally under Camp Commandants, who are responsible for sanitation, just as billet towns are under Town Majors. It will be the duty of some of you to work with these officers, and you should therefore be familiar with sanitary requirements.

SANITATION IN BILLET TOWNS.—The sanitary personnel is responsible for billets, tents, and lines occupied in a village to exactly the same extent as in

camp. If there is a central incinerator, all the refuse should be removed there, where it is disposed of by men under the Town Major. Manure should be removed to the authorized dumps. All latrines, billets, cookhouses, and mess rooms should be kept in a cleanly state.

The Town Major is responsible for the general sanitation of billet towns. He usually has a staff of "P.B." or "T.U." men attached, and one or more sanitary inspectors from the sanitary section as advisors in sanitation. If no permanent men are on his staff he has authority to call upon the nearest unit to provide fatigues necessary for cleaning up roads, streets, drains, and accumulations of refuse. He should, if the men are available, have one large incinerator erected on the outskirts of the town, to which all refuse should be brought before 10 a.m.

Units in the village having transport must bring their own refuse; where units have no transport they will bring all garbage to the incinerator in hand carts that are usually available. He should see that the area around incinerators is kept clean, and all burnt tins removed and buried, or otherwise disposed of. The Town Major is also responsible that all horse manure is removed to a dump and "close packed." This can only be satisfactorily done when a man is detailed for duty at the dump, who reports to the Town Major any unit not complying with the regulations.

The situation of the manure dump and incinerator should be selected by the Town Major in conjunction with the sanitary officer of the area. The situation of these and also the location of water points should be given to all incoming units by him. He is also responsible that streets, yards, and drains are kept clean. There is great danger of spreading diseases through mud and dust. Although germs will not live very long in mud or dust, still on account of the enormous numbers present there is much danger, and every effort should be made to keep the streets and

drains clean. The practice of scraping the mud off the centre of streets and allowing it to accumulate on the sides should not be permitted. Arrangement should be made giving each unit in the town a certain area to keep clean. The mud should be removed half a mile away from the limits of the town. The Town Major should see that garbage is removed to incinerators. Instructions should be issued to all units to have garbage ready for removal at 9 a.m. One or two G.S. waggons may be demanded from units alternately for this purpose. When garbage is removed in this way arrangements should be made with the local mayor, so that civilians be prohibited from putting any garbage on the public streets between the hours of 9 a.m. and 9 p.m.

In billet towns there should be proper receptacles for refuse placed at prominent street corners and near *estaminets*, cinemas, and Y.M.C.A. huts to prevent refuse from being thrown on the street. Much difficulty is sometimes met with in dealing with middens. However, the Town Major can furnish labour and transport to remove all manure to the fields of the farmer, and arrangements can generally be conveniently made through the French Mission.

Sometimes middens and watering-places in billet towns get filled with dirty water and drainage from streets, stables, and urinals. These constitute a great nuisance in summer on account of offensive odour and as breeding-places for mosquitoes. They should be pumped out, the muck at the bottom removed, and then they should be allowed to fill up with clean water. Town Majors and Camp Commandants are given very large powers, and can compel units to keep their areas in a clean and satisfactory condition. No units should be allowed to move out of billet town or area without having received a clearance certificate from the Town Major. If a unit should go away without such and leave the area in an unsatisfactory state, the Town Major has authority to make the offending unit send back a fatigue party to clean up.

WATER-DUTY PERSONNEL.—I cannot too strongly impress upon water-duty personnel their great sense of responsibility. There is no more important work in the field than the safeguarding of water supplies. Non-commissioned officers and men specially trained in water duties should constantly inspect all water supplies in their area.

They should see that no pollution gets access to streams, reservoirs, wells, and watercourses of any kind. Very frequently units place tents or construct dug-outs close to the edge of canals, moats, rivers, or streams; if this is permitted, contamination of the water will certainly occur, either through the latrines, urinals, or waste products from living places.

They should also inspect all wells or springs in the area, and report those that should be closed or marked as unfit for drinking, and if fit the quantity of "lime" required for sterilization. They should ascertain whether the waste water from the cookhouses, baths, ablution tables, or laundries goes into any watercourse without treatment. They should patrol their area every day and see that no contamination occurs either at the source, storage, or distribution of the supply.

Twice a month at least all water-carts in the area should be tested for free chlorine, the condition of the cart noted, and fittings examined and reported upon. This report should state if all parts of the cart are in good condition, if any are missing, if there is a sufficient amount of bleaching powder, alum, or chlorinated tablets. They should note whether water-carts, tanks, barrels, or other receptacles for containing water are periodically cleaned and scrubbed with bleaching powder. They should visit all canteens to see that no unauthorized mineral waters are on sale, and that all water used in the preparation of "soft drinks" and milk has been properly chlorinated. They should see that all units not provided with water-carts take adequate and proper measures to chlorinate small quantities of water.

DIRTY CAMPS.—You are now familiar with the

sanitary requirements of camps and barracks, and as a contrast I should like to point out to you the conditions that are often found on every day inspections. Latrines are situated a few yards away from kitchens or water supplies. If fly-proof originally, lids are missing, the covers do not fall down automatically, or they are tied to the rail at the back to prevent them from closing. There are cracks or holes in the sides of the latrines through which flies may enter. Papers are scattered all around the latrine, and there is no evidence that the woodwork has been lately scrubbed with cresol. If pit latrines are in use no attempt is made to cover the excreta, and flies abound everywhere. If camps are in woods or close to hedges, trenches, or shell holes, there is fouling of these places with human excreta, a practice that, apart from the great danger, is most disgusting.

If pail latrines are in use, the pails show no evidence of ever having been washed or disinfected, and particles of solid excreta are visible on the sides. The excreta dump is not covered with earth, or not sufficiently covered, thus attracting flies. Occasionally bucket pails are filled to overflowing, and left in conspicuous places by departing units to be found by those taking over, who often for a day or two will refuse to do the necessary cleaning up. Incinerators are found full, and the ground littered with every description of unburnt refuse which is covered with flies. There may be no incinerator at all, and holes in the ground are filled with uncovered and unburnt refuse.

MESSES AND KITCHENS.—Messes and kitchens are often found in a very unsanitary state, officers' messes especially being open to criticism. On one occasion an inspection of an officers' mess showed an unsatisfactory condition of things. The cooks and helpers were not at all clean-looking, their clothes were dirty. The tables on which the food was prepared and the meat blocks were dirty and greasy. Dish-cloths were dirty and greasy, and gave the impression of being

seldom washed. Men were sleeping in the kitchen, kept their kits there, shaved and washed in it, and also cleaned their boots in the kitchen. Scraps of food were lying round the kitchen; no food safes were provided; jam, butter, and bean tins were left opened, and the whole mess swarmed with flies.

Outside the mess conditions were no better. Some cresol drums were used for the reception of solid and liquid refuse, but they were not provided with covers; some of them had filled up, and the ground around was covered with greasy liquid. Tea leaves were thrown in a hedge close to the kitchen, also refuse and scraps of food. No proper arrangements were made for the disposal of liquid refuse, and small uncovered pits with great masses of decomposing organic matter were literally black with flies.

On another occasion an inspection of a double-bunked hut showed that scraps of food, jam tins, cigarette ends, papers, and such stuff had been thrown under the lowest bunk, where it had likely remained for some days. The floors were very dirty, smelly, and greasy, with no sign of having been washed recently. Some of the men were sitting in front of the hut cleaning their mess tins with sand picked up on the footpath leading to the road. A short distance away some men of this unit were drinking water from a pump close to a midden in the yard of a civilian, though the water-cart was not more than twenty yards away. It is not uncommon to find the conditions just described, and the only remedy is to report, and keep on reporting, the unit concerned until proper action is taken.

You may sometimes be asked to submit standing sanitary orders for a camp, and for that reason you might make a note of the following as forming a basis for such standing sanitary orders.

SANITARY STANDING ORDERS.

(1) It is absolutely forbidden to use any water for drinking purposes other than properly chlorinated water.

(2) All solid excremental matter should be burned in an incinerator constructed for that purpose. Where incineration is impossible, deep pits with fly-proof seats must be used. All latrines must be kept clean. When pails are used they should be, after emptying, cleansed and treated with heavy oil and sawdust, or a solution of cresol 1-300 placed in the bottom. The seats must be scrubbed daily with a solution of cresol and water. Toilet paper should be provided.

(3) Proper urinals leading into separate closed pits should be constructed. During hot weather urinals should be frequently sprayed with crude oil or cresol.

(4) Each hut, billet, or series of tents must have a fly-proof receptacle for rubbish, and this rubbish is to be collected daily and burned in an incinerator. All empty tins and bottles must be burned and afterwards buried.

(5) Refuse from kitchens must be kept in fly-proof receptacles, and if given to farmers should be systematically removed. Proper fly-proof grease traps should be provided at every cookhouse. All food should be stored in fly-proof receptacles. Cooks or assistants must not wash, shave, sleep, or keep their clothes in cookhouses. No man of dirty habits should be employed in a cookhouse. No man who has recently had an infectious disease or is a known "carrier" should be employed in a cookhouse. Food safes should always be provided, and cooking utensils cleaned with boiling water.

(6) Food must not be kept in tents or huts, but should be stored in fly-proof receptacles. Mess tins and dishes must not be cleaned with sand unless the sand has been roasted. Tables must be scrubbed after each meal. The floors and walls of huts must be kept

clean by washing and sweeping. Spitting is forbidden, except in small boxes filled with sand or sawdust. The sand or sawdust should be burned in the incinerator.

There must be no overcrowding, and the windows should be kept open day and night, weather permitting.

All washing places must be kept clean and provided with grease traps. The practice of washing indiscriminately within the lines and throwing waste water on the ground must not be permitted.

(7) Drains around huts, grounds, and in the area of streets must be kept clear of all kinds of rubbish. No waste paper or rubbish of any kind is to be thrown into the drains, on the ground, or around and under huts.

All horse manure must be (a) removed to authorized dump and close packed; (b) given to farmers to remove under strict supervision; (c) sprayed with kerosene or cresol. All stables and horse lines must be kept clean and free from refuse of all kinds.

(8) Pools or ponds of stagnant water (breeding-places of flies) must, when possible, be drained or sprayed with cresol or kerosene.

LECTURE VIII

Sanitary Appliances

The drawings shown in the following pages were made from devices prepared in connexion with a demonstration of sanitary fixtures. Types are shown that can readily be improvised in the field. Most of them are to be recommended, though some are inserted for the purpose of pointing out defects.

It is not the intention that these types be rigidly adhered to. Indeed, it is expected that improvements will be made upon many of them. It is worthy of note that nearly all the articles exhibited can be made from salvaged materials of little value and available in every camp, namely, biscuit and bacon boxes, petrol tins, and cresol drums, corrugated iron, expanded metal.

URINALS.

FIG. 1.

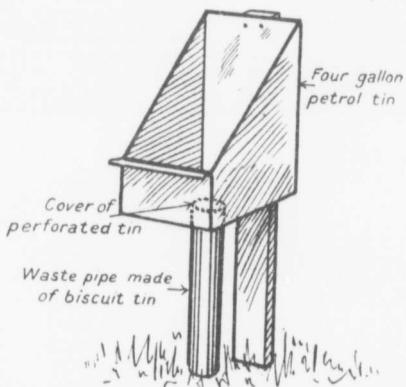
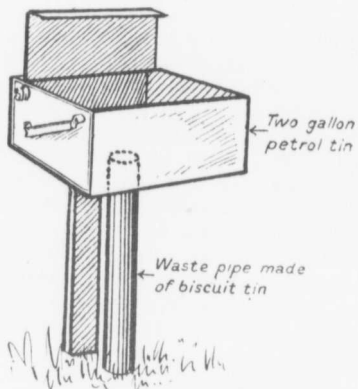

FIG. 2.

FIG. 1.—Made from a two-gallon petrol tin, with one side raised to prevent splashing; oiled to delay rust formation. The urine passes through the waste-pipe, made from biscuit tin, and enters into pit filled with stones, broken brick, or burnt perforated tins.

FIG. 2.—Made from four-gallon petrol tin with lip on front to prevent splashing. The bottom of petrol tin should be cut and bent downwards on the inside of the waste-pipe to prevent leakage. A piece of perforated tin should be placed over the waste-pipe in every type of urinal to prevent the pipe being blocked by odds and ends.

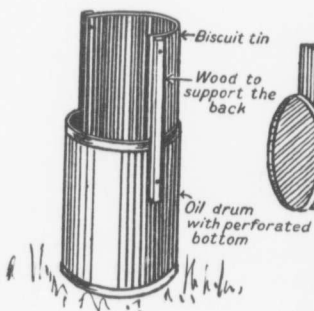

FIG. 3.

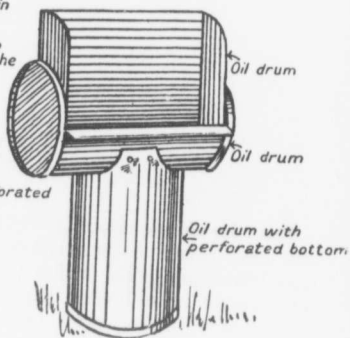

FIG. 4.

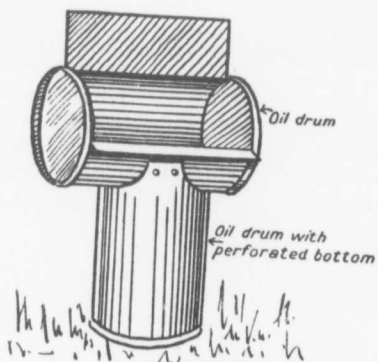

FIG. 5.

FIG. 3.—Made from damaged oil drum with holes in bottom, with back of biscuit tin supported by three strips of wood. This type is suitable for fairly loose soil, and can be set over pit filled with stones or burnt perforated tins.

FIG. 4.—Made from three damaged oil drums. The lower drum is perforated at bottom.

FIG. 5.—Made from two oil drums. The upper drum has been cut and iron raised to provide a back and lip.

FIG. 6.

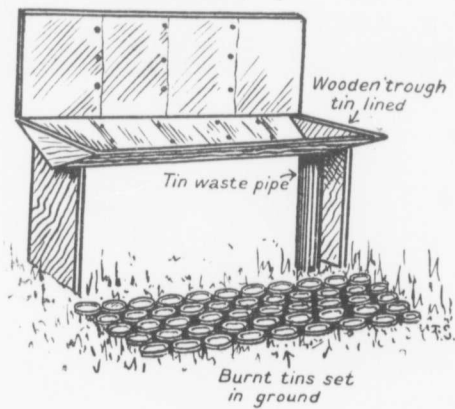
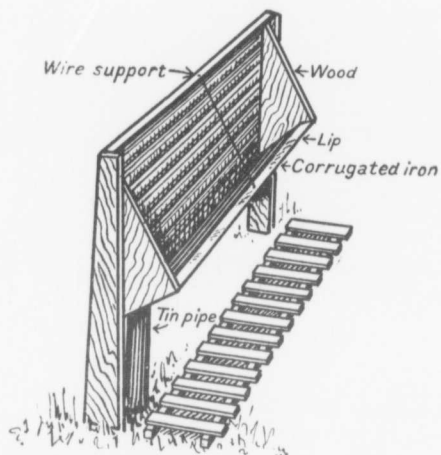

FIG. 7.

FIG. 6.—Constructed from one sheet of corrugated iron, bent at a suitable angle, and closed in at both ends to prevent leakage. The waste-pipe leading into the pit is made from old biscuit tin, painted to prevent rust.

FIG. 7.—Wooden trough; back lined with biscuit tin, with waste-pipe leading into soakage pipe. Trough is supported by two stout strips of wood secured in ground.

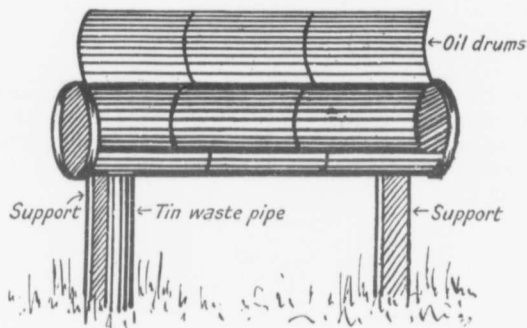

FIG. 8.

FIG. 8.—An improvised urinal made from three oil drums and supported by two strips of wood secured in the ground. The waste-pipe is made from old biscuit tins, painted to prevent rust. These urinals are best placed adjacent to the latrine with separate soakage pits, and within the screen if supplied. The waste-pipe should go to the bottom of the pit if the ground is not absorbent.

LATRINES.



FIG. 9.

FIG. 9.—Made from four-gallon petrol tin with detachable seat. The nail at the front secures the seat to the petrol tin. The wood support at the back keeps the seat firm.

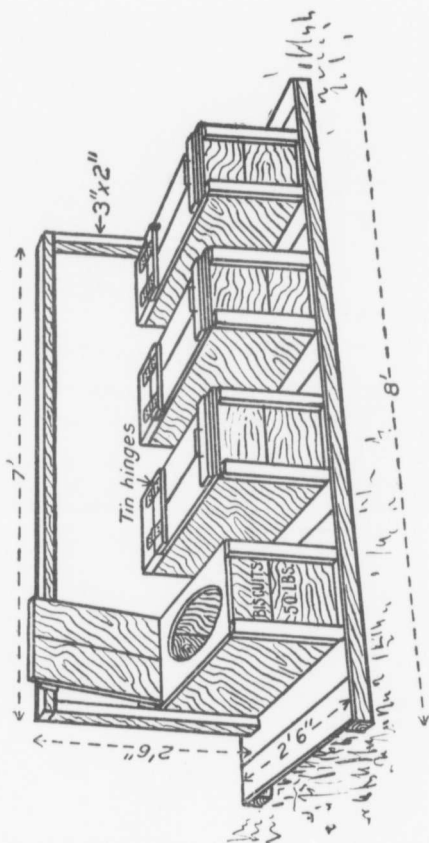

FIG. 10.

FIG. 10.—Made from biscuit boxes with self-closing lids and urine deflectors to prevent fouling of ground in front. The rail for automatic closing is made of wood. Wire is sometimes used instead of wood, but is not to be recommended. The base is 8 ft. in length. This allows for a convenient space of 10 in. between each seat. The dimensions of pit required for this type are 7 ft. by 2 ft. by 8 ft. Although sufficiently strong, the whole can be removed bodily to a new pit. Staples interlocked—when they are available—make simple and satisfactory hinges.

FIG. 11.

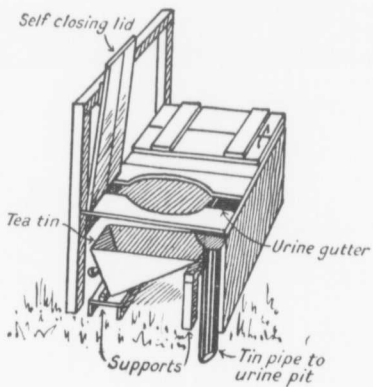

FIG. 12.

FIG. 11.—Single seat pit latrine made from biscuit box, with self-closing lid and tin urine shield. This type is easily constructed, and can be used as an officers' latrine.

FIG. 12.—This type of latrine can be installed when the contents of the latrine buckets have to be burned. The urine is received by the tin trough, and flows down the waste-pipe into soakage pit. This enables the solids to be removed without danger of spilling, and also makes incineration much easier.

FIG. 13.

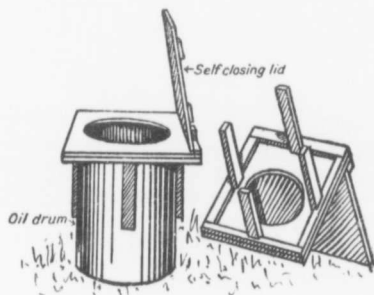
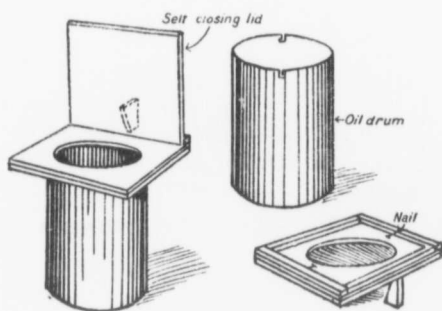

FIG. 14.

FIGS. 13 and 14.—Two improvised latrines with self-closing lids, suitable for front line trench use.

FIG. 13.—Shows a simple arrangement of securing the cover to the drum.

FIG. 14.—The four supports fastened to the cover keep the seats firm.

FIG. 15.

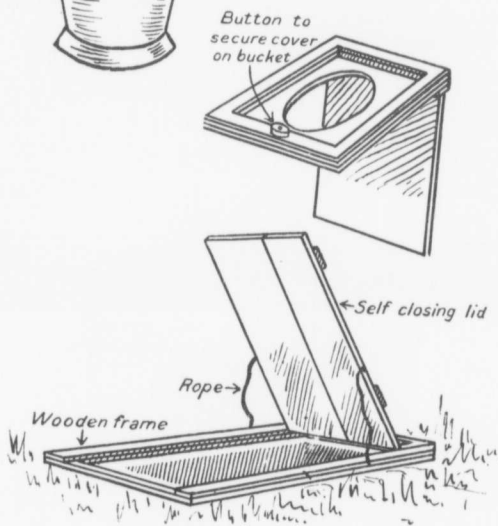
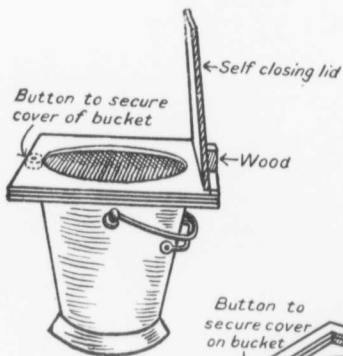

FIG. 16.

FIG. 15.—Shows a fly-proof seat with self-closing lid. The seat is made secure by a turn of a button on the underside of the seat.

FIG. 16.—Squatting latrine with self-closing lid. Not recommended on account of difficulty of keeping clean; foot rests easily fouled. This type also requires much lumber.

FIG. 17.

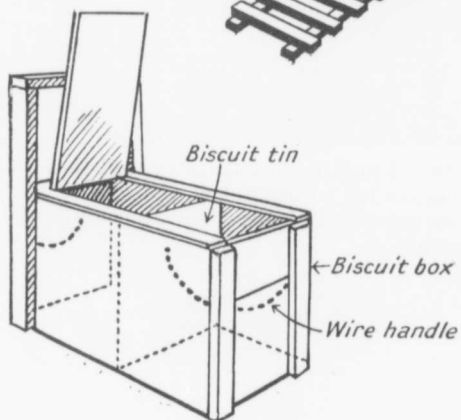
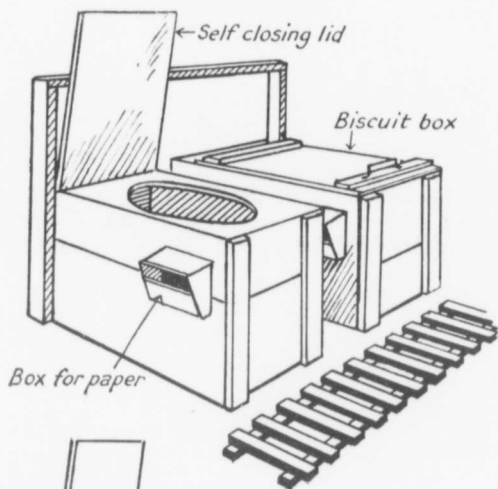

FIG. 18.

FIG. 17.—Box latrine with self-closing lids and tin urine deflectors. All material except rail and supports can be obtained from biscuit boxes.

FIG. 18.—Latrine made from biscuit box with self-closing lid and two biscuit tins inside. This method keeps the solids comparatively dry, and can be removed without danger of spilling.

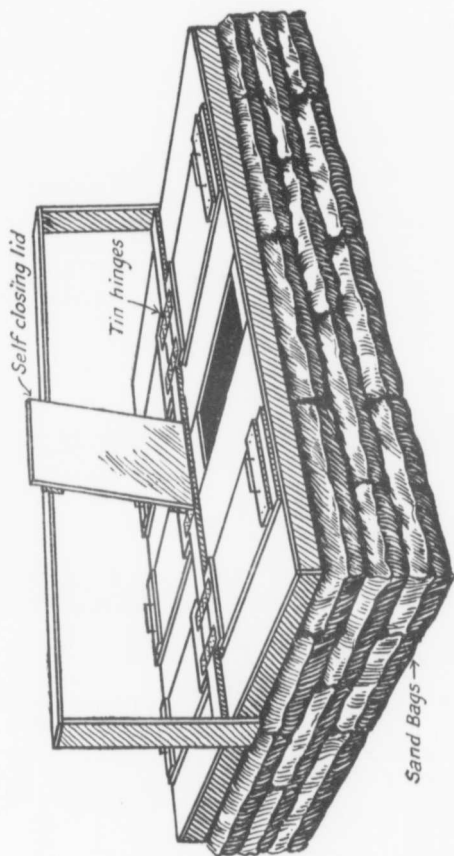

FIG. 19.

FIG. 19.—Deep fly-proof latrine with self-closing lids and tin urine shields to prevent escape of urine between the sandbags. Sandbags can be used when the supply of lumber is limited.

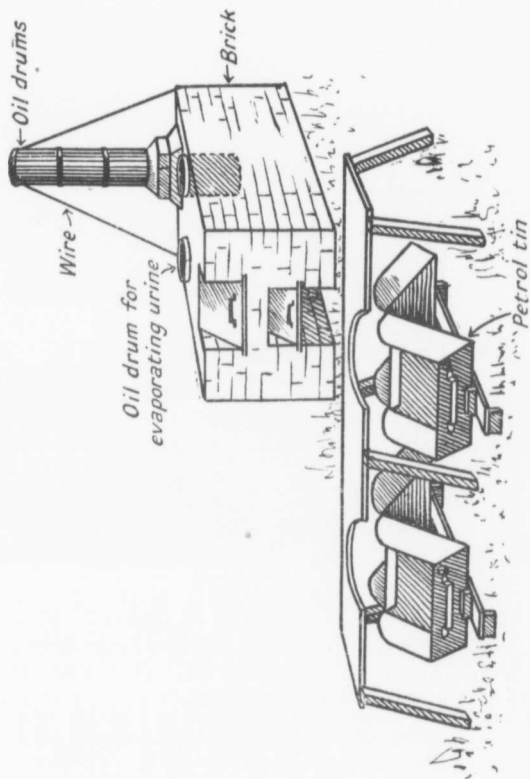

Fig. 20.

FIG. 20.—This latrine can be made from petrol tins placed as shown in diagram. The incinerator should be conveniently sited, so that the contents of the buckets can be removed and burned. (Macpherson's model.)

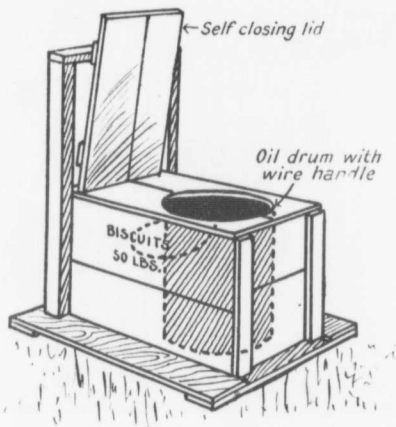

FIG. 21.

FIG. 21.—Fly-proof latrine improvised from oil drum and biscuit box with self-closing lid. This type may be used as a deep pit or pail latrine.

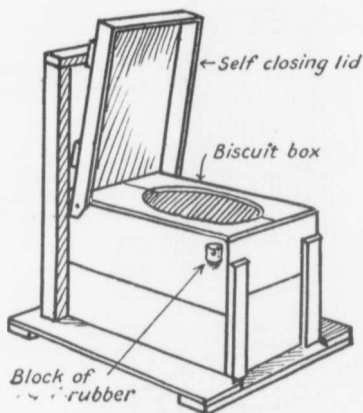

FIG. 22.

FIG. 22.—This type of latrine is suitable for listening posts, advanced saps, crater lips, and positions close to the enemy. The lid is constructed so that in falling it holds a considerable quantity of air which, compressed, acts as a cushion. A hollow block of flexible rubber on each side adds to the efficiency. It is practically silent when set over a deep pit.

GREASE-TRAPS.

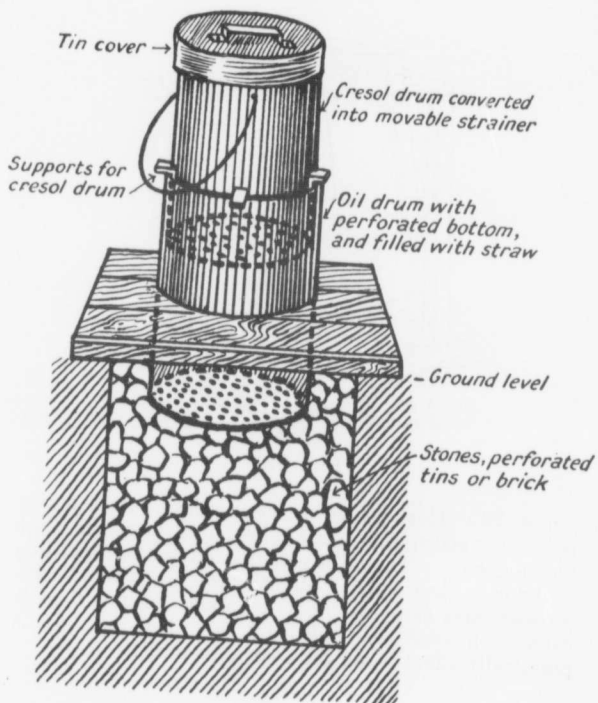

FIG. 28.



FIG. 23.—Grease-trap and soakage pit suitable for small cookhouse improvised from oil drums and cresol drum with cover. The inner drum is perforated at bottom, and serves as a coarse strainer. The outer drum is perforated at bottom, and contains grease-catching material, hay or straw, which must be removed daily. The soakage pit can be filled with some burnt tins. This type can be installed if the ground is absorbent.

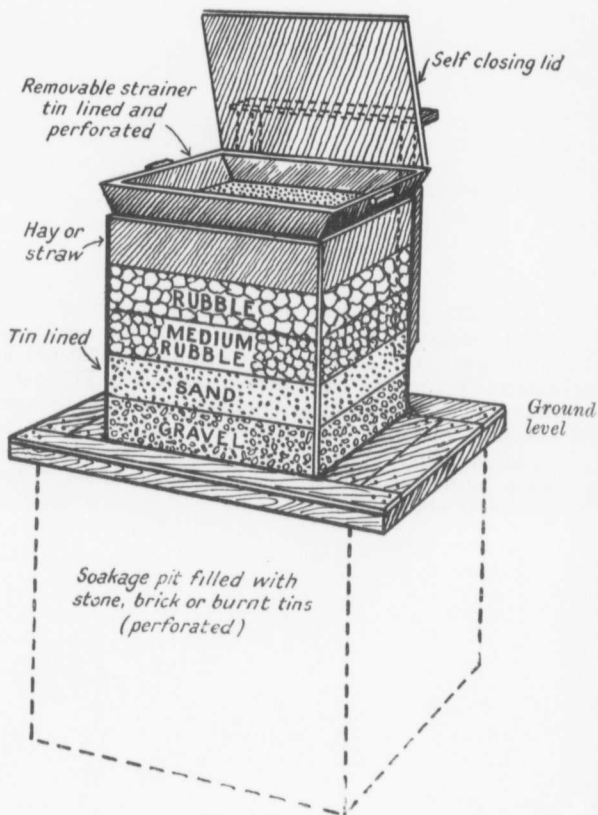

FIG. 24.

FIG. 24.—Grease-trap with self-closing lid and removable strainer. Filter chamber is perforated at bottom. A good plan is to fill the upper portion of the filter chamber with hay or straw, sprinkled with chloride of lime. This catches and holds the grease, allowing the clearer liquids to run freely away through the filter and into soakage pit filled with stone, brick, or burnt tins. The hay or straw must be burned and renewed daily. Most of the material required for this type can be obtained from bacon boxes and biscuit tins.

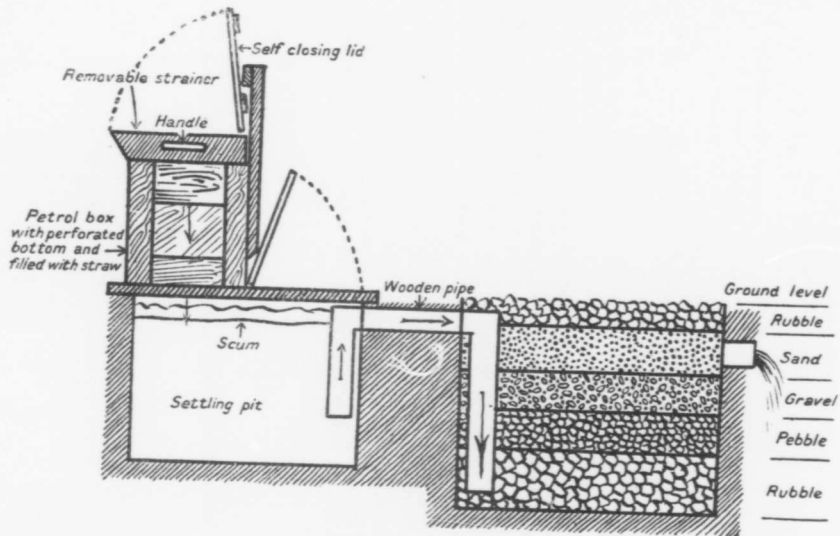

FIG. 25.

FIG. 25.—Grease-trap with strainer and filter bed for sullage water. This method is suitable in places where ground is not absorbent. The strainer is made from bacon boxes and is perforated at bottom. The hinges from a petrol box are used on the self-closing lid above the strainer. The petrol box is perforated at bottom, and contains hay or straw, which must be removed daily. To increase the efficiency chloride of lime should be added to waste water in settling pit. This should be thoroughly mixed and allowed to remain overnight. The scum should be removed each morning. The chlorinated water passes through the wooden pipe, and enters the filter bed close to the bottom. The water rises through the filter bed composed of rubble, medium rubble, gravel, and sand, and can be turned into any stream or ditch.

HEATERS.

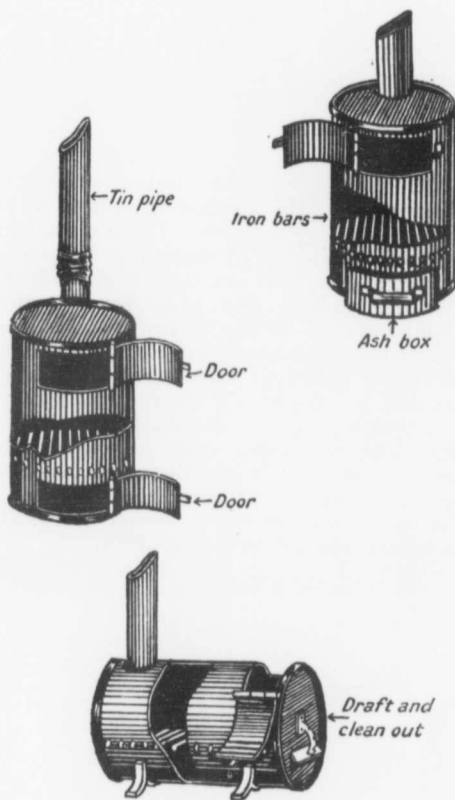

FIG. 26.

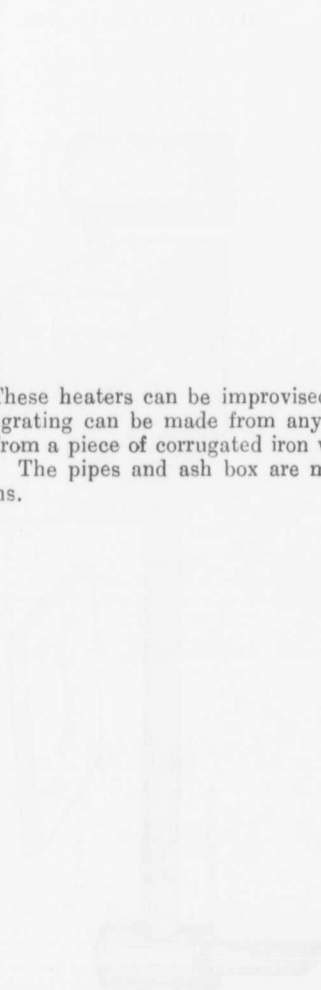

FIG. 26.—These heaters can be improvised from oil drums. The grating can be made from any available iron bars, or from a piece of corrugated iron with holes for air inlets. The pipes and ash box are made from old biscuit tins.

BARRACK-ROOM HEATER.

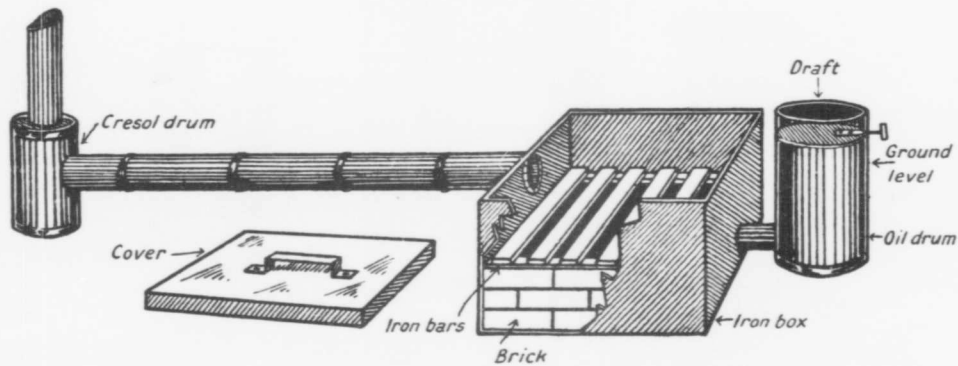

FIG. 27.

FIG. 27.—All material except bricks and iron bars can be improvised from oil drums and corrugated iron. Box and cover made either from oil drums or corrugated iron; should be set in ground to its own depth. The check draft is an oil drum with the top cut out, and used to regulate the supply of air. For a wood fire some of the bricks can be taken away and the grating lowered. The pipes can be made from oil drums or corrugated iron. This type of heater may be used in special rooms for drying clothes, if an improvised frame is placed over the pipe, which is preferably a couple of feet above the ground.

FOOD SAFES.

These food safes are made from ordinary biscuit boxes. The doors are made from the lids with leather or tin hinges. One or two boxes may be used, depending on the size of the mess. They are ventilated, lined with tin for cleanliness, and fitted with a tin tray (made from biscuit tin) for catching blood. They are cheap, portable, and fly-proof, useful for storing bread, jam, butter, meat. Collapsible food safes are made so that they can be easily carried from one area to another, and when placed on a wagon take up very little room.

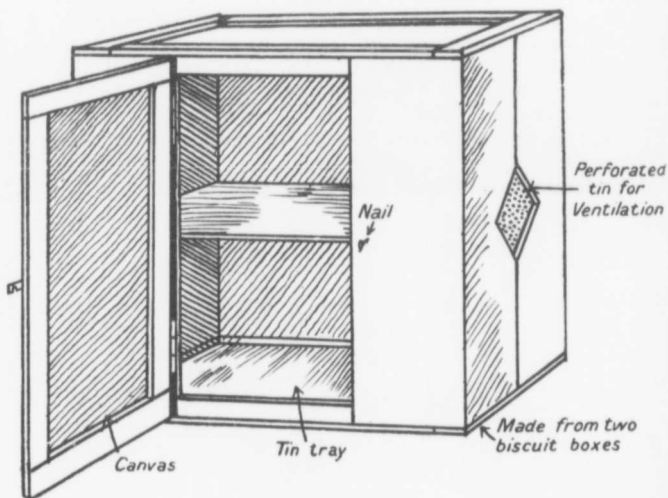

FIG. 28.



FIG. 28.—Made from two biscuit boxes with perforated tin on both sides for ventilation. The door is made from wood and canvas; removable tin tray on lower shelf. The hinges are made from old biscuit tin and wire.

FIG. 29.

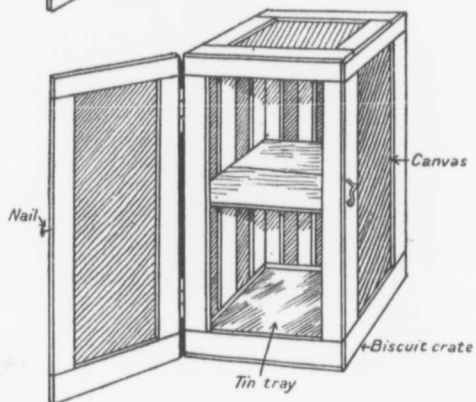
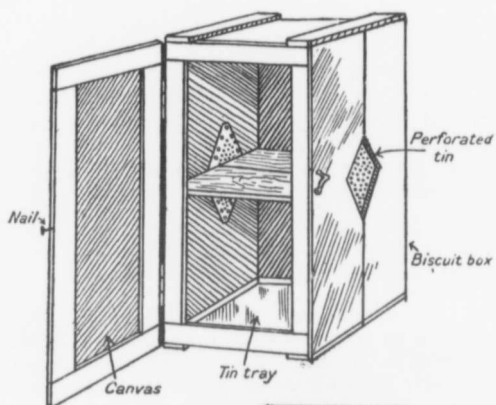

FIG. 30.

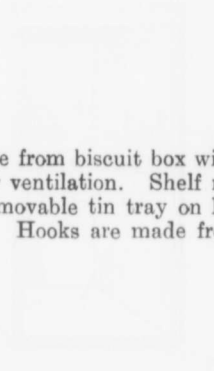

FIG. 29.—Made from biscuit box with perforated tin on both sides for ventilation. Shelf made from lid of biscuit box. Removable tin tray on lower shelf made from biscuit tin. Hooks are made from nails.



FIG. 30.—Made from a biscuit crate with canvas sides and top. Tin tray on lower shelf. The hinges and hooks are improvised from nails and biscuit tin.

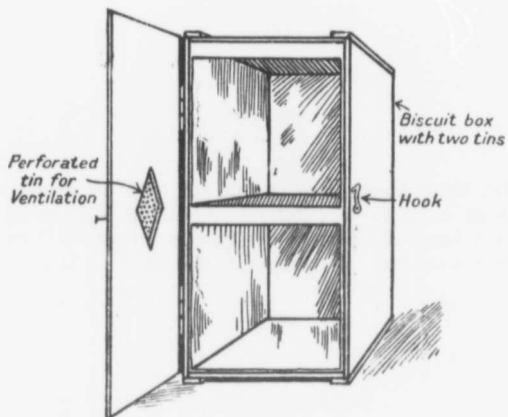

FIG. 31.

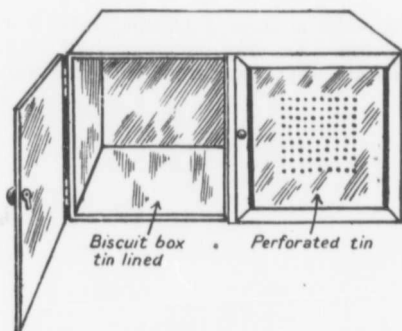

FIG. 32.

FIG. 31.—Made from a biscuit box and two tins. The tops of the biscuit tins are cut away and then replaced in the box. The door is made from a lid of a box. Hinges and hooks are made from nails and biscuit tin.

FIG. 32.—Biscuit box, tin-lined; door made from lid of box. The door on the right is made from wood frame and perforated tin for ventilation.

MEAT SAFES.

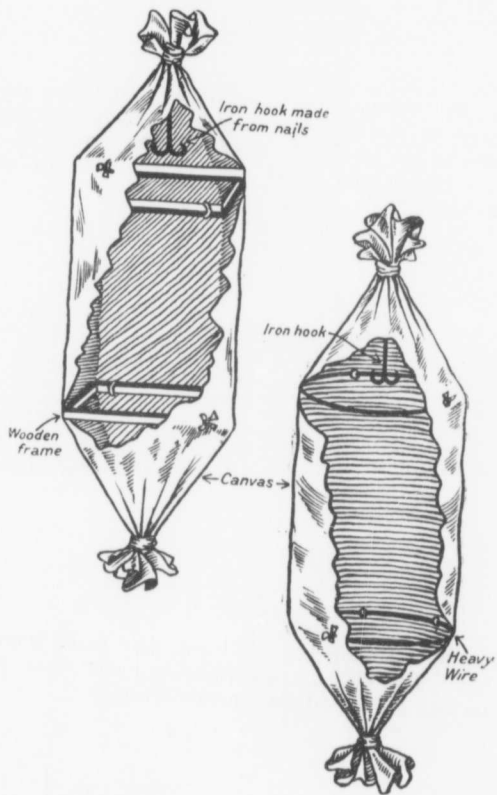

FIG. 33.

FIG. 34.

FIG. 33.—Made from two wooden frames covered with sacking.

FIG. 34.—Made from two iron hoops covered with sacking.

FIG. 35.

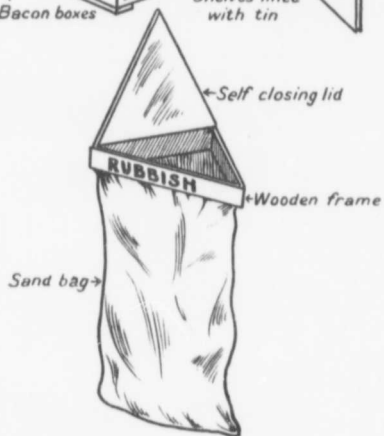
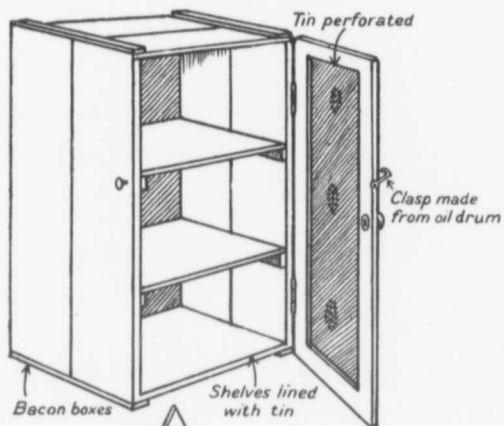

FIG. 36.



FIG. 35.—Food safes made from two biscuit boxes lined with tin. The shelves are made from lids of boxes. The door is made from wood frame and tin perforated for ventilation.



FIG. 36.—Dry refuse bag with self-closing lid. The sandbag hangs from a nail at each corner. This arrangement can be nailed to a wall or post, which acts as a lever and causes the lid to close automatically.

REFRIGERATOR.

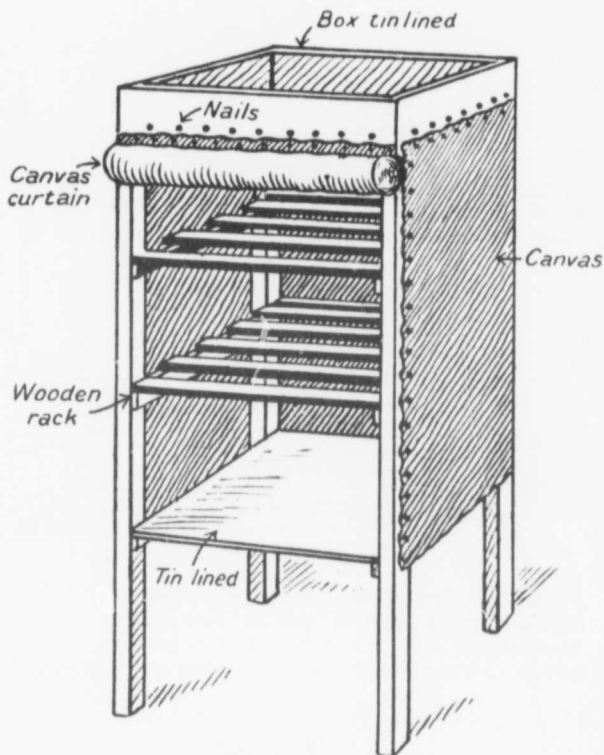

FIG. 37.

FIG. 37.—Wooden frame with shelves. The frame is covered with canvas. The canvas curtain in front is weighted with an iron rod. The tin-lined box containing water is perforated at the sides with nail holes to allow water to drip slowly on sacking. Water-soaked canvas chills the air inside the refrigerator.

FIG. 38.

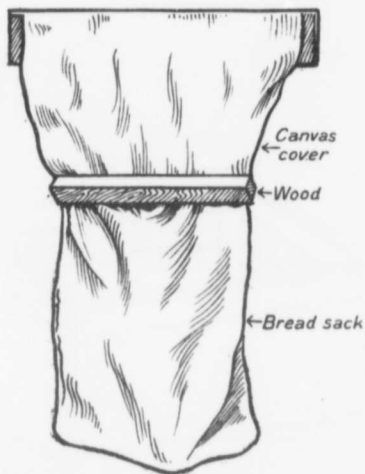

FIG. 39.

FIG. 38.—Fly-proof sack for dry refuse, suitable for trenches and camp huts.

FIG. 39.—Oil drum with handle and fly-proof cover for refuse. Can be placed between huts or tents in men's lines.

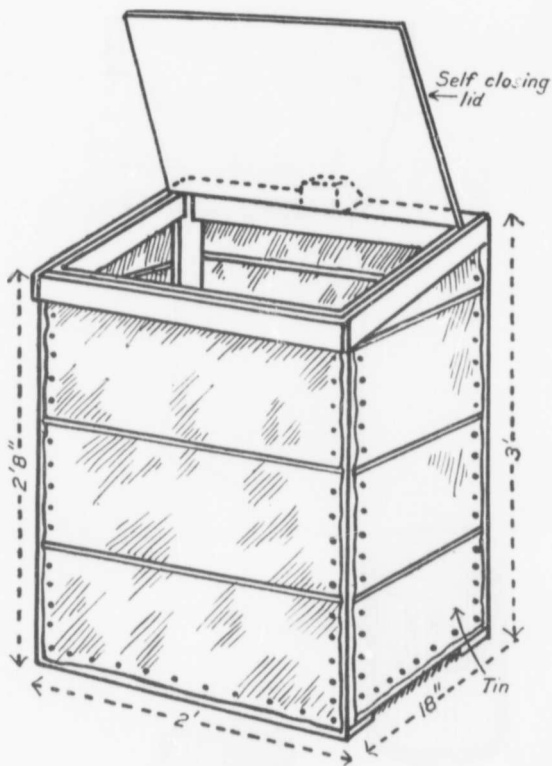

FIG. 40.

FIG. 40.—Large refuse box with self-closing lid, suitable for towns. Framework covered with wire netting and canvas on the outside. Bottom made from wood.

GREASE-TRAPS.

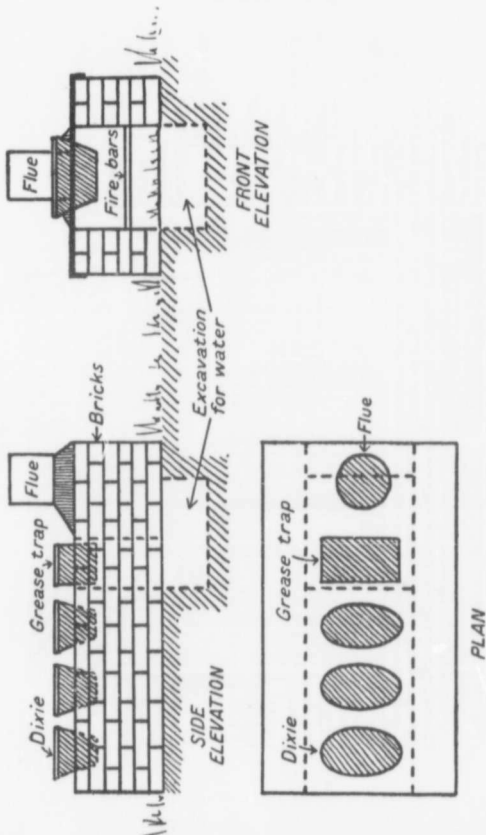

FIG. 41.

FIG. 41.—Method of disposal of kitchen sullage by evaporation. The trap for straining off solids can be improvised from biscuit or petrol tins. The sides of the excavation should be lined with corrugated iron. The iron preserves the heat, and, being a conductor of heat, assists in evaporation of waste water.

KITCHEN IN RESERVE AREA.

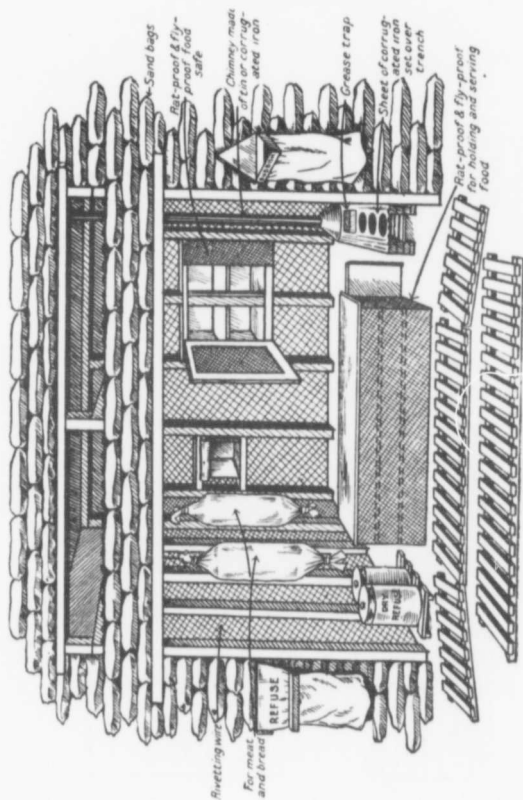

FIG. 42.

FIG. 42.—The sanitary fixtures shown in this sketch are rat-proof and fly-proof, and can be improvised from materials available in the reserve area. The kitchen sillage can be disposed of by evaporation.

ABLUTION TABLE.

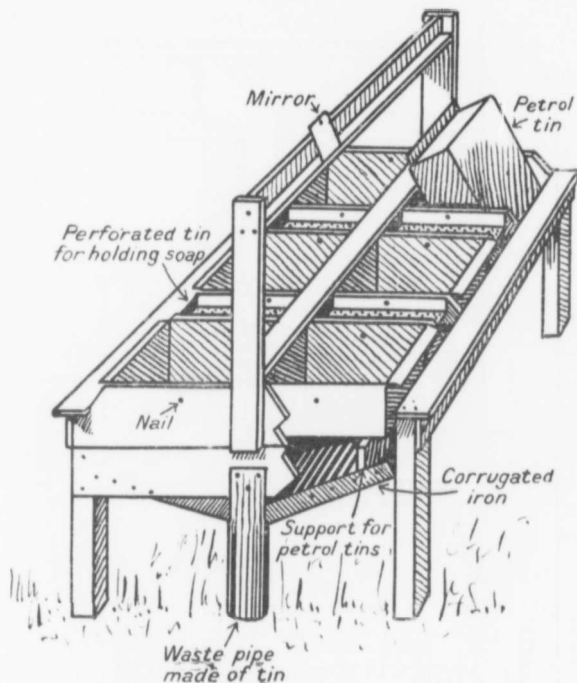

FIG. 43.

FIG. 43.—Wash bowls can be made from petrol or biscuit tins. The bowls are held by nails placed a little more than half-way from the front. Soap boxes are made from tin with perforated bottom and nailed between bowls. Rail is made for holding mirror at convenient angle for shaving.

IMPROVED VAPOUR BATH.

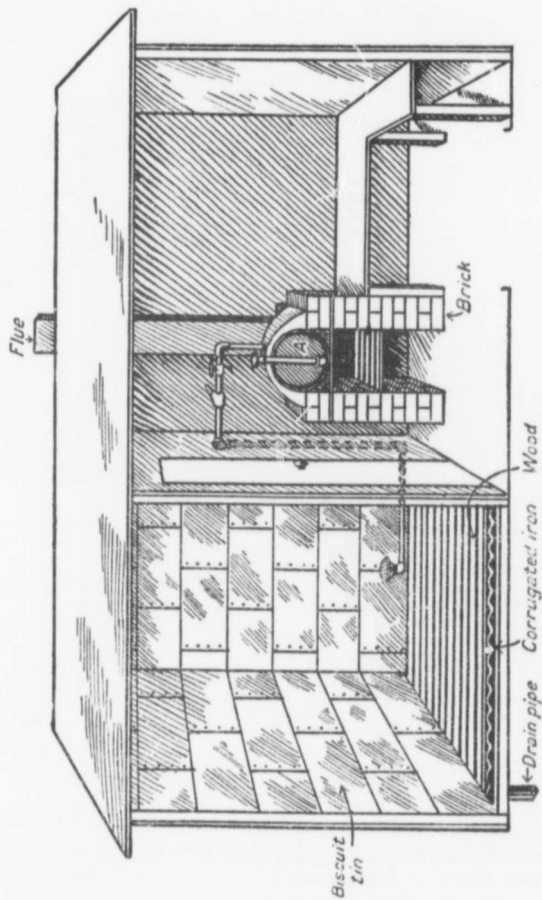

FIG. 44.

FIG. 44.—The boiler can be improvised from oil drum. The iron pipe (A) is fitted with a simple safety valve made from tin, and can be removed when the boiler requires a supply of water. Supply pipe with stop-cock enters the boiler from the top. When the stop-cock is opened the steam passes out through the 6-inch spray. The cabinet is lined with tin to prevent escape of steam. The floor of bath-room is lined with sheets of corrugated iron, and over these are placed a number of trench boards; the flue is made from corrugated iron. It is cheap, easily constructed, and suitable for rest stations.

ABLUTION TABLE WITH SCHEME FOR TREATING WASTE WATER.

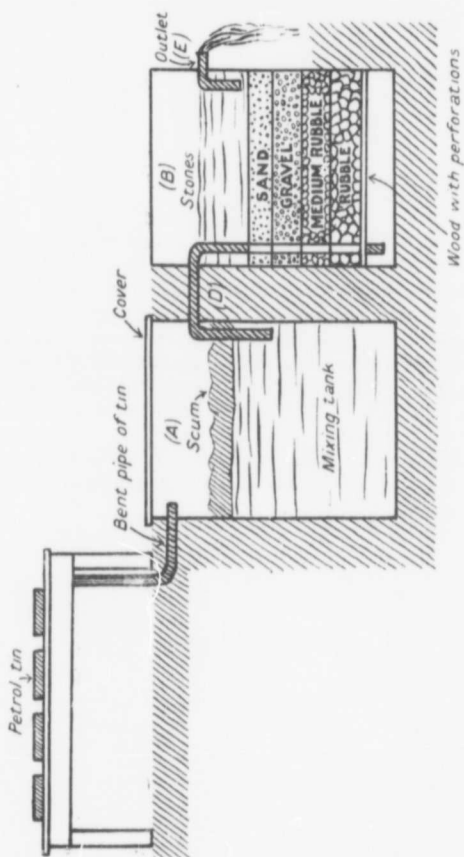

FIG. 45.

FIG. 45.—The waste water from the ablution table flows through the bent pipe and enters pit (A). Each day chloride of lime is added and mixed thoroughly and the scum removed every morning. The pipe (D) receives the waste water well below the scum in pit (B), and rises through the filter and comes away through outlet (E).

TREATMENT OF WASTE WATER FROM BATH-HOUSES.

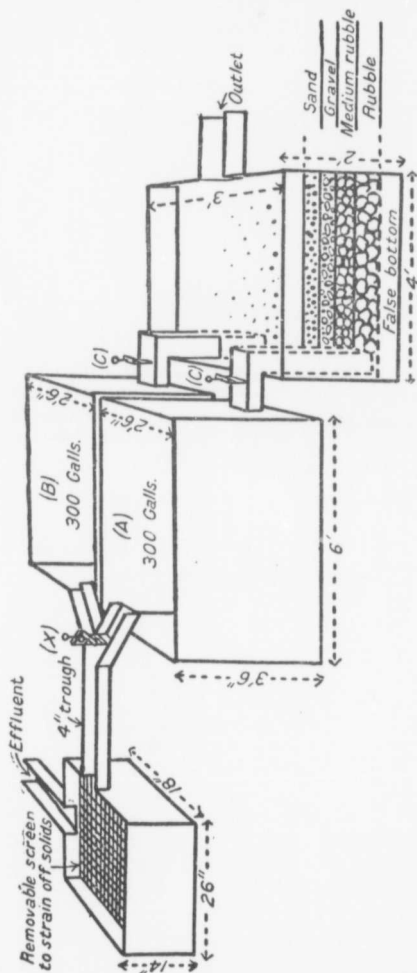

FIG. 46.

FIG. 46.—(A) and (B) are two wooden tanks painted inside and outside with tar, each capable of dealing with one day's flow. Chloride of lime 1 per cent. is added, thoroughly mixed, and allowed to remain overnight. The following morning the soap and flocculent precipitate are removed and valve (C) opened to allow for filtration. (A) and (B) are used alternately and are controlled by valves at (X). Communication between each tank, and the filter is by means of a 2 in. pipe with a valve, stop-cock, or wooden box with valve, let in 1 ft. above the floor of the tank, and discharging at bottom of 3 ft. filter bed. The filter bed is composed of broken brick or rubble with a layer of shingle and 4 in. of sand on top. The capacity of the tank in sketch is 300 gallons a day. The dimensions of the tank should be 20 ft. by 12 ft. by 4 ft. 6 in., the dimensions of the filter 10 ft. by 8 ft. by 3 ft. The scum may be dried and burnt in the incinerator. An effluent bright, clear, and sterilized results, which can be used again for washing purposes or turned into any stream or ditch.

TREATMENT OF WASTE WATER FROM BATH-HOUSES.

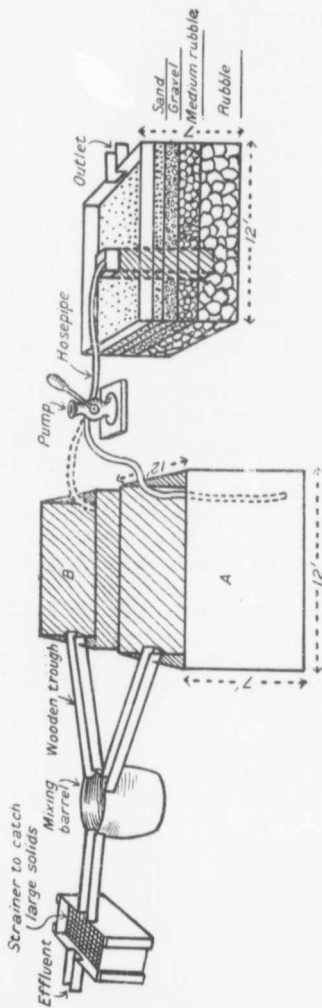

FIG. 47.

FIG. 47.—The sketch shows a method of disposal of waste water from bath-houses. Chloride of lime is added, and thoroughly mixed with waste water in barrel in proportion of $\frac{1}{2}$ to 1 per cent. The mixture then flows into tanks (A) and (B), which are used alternately, and are controlled by a block of wood placed in the trough near the barrel. Each tank is capable of dealing with one day's flow, and when full should be allowed to remain overnight. The following morning the greasy scum is removed, and the clearer water pumped out and forced upward through the filter. The water can be used again or turned into any stream or ditch. The tanks in sketch are pits in the ground lined with corrugated iron.

DESTRUCTOR AND URINE SOAKAGE PIT.

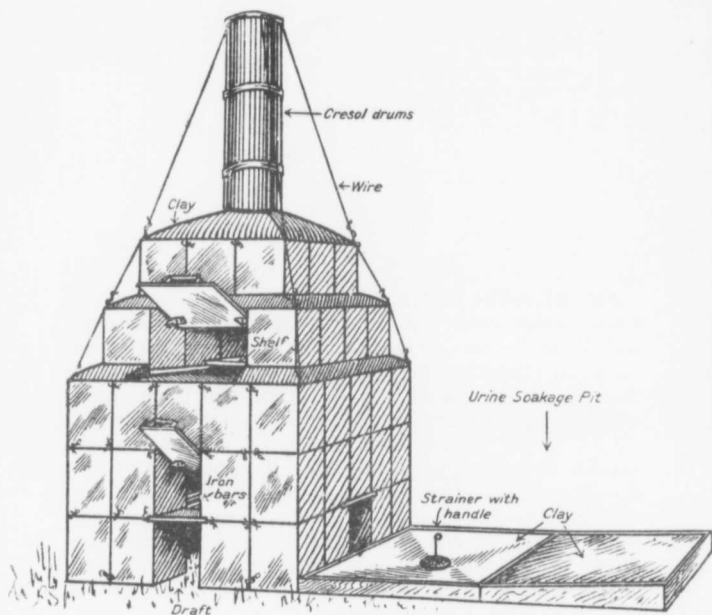

FIG. 48.

FIG. 48.—This destructor can be improvised from damaged biscuit or petrol tins, and is particularly suitable when contents of latrine buckets must be burnt. 75 tins are required. The grating can be made from any available iron bars, best placed from front to back to facilitate cleaning. All tins must be filled with clay and fastened by wire hoops to give strength. The doors with handles are made from oil drums, and the drying shelf is made from corrugated iron. Urine soakage pit. Wooden frame filled with clay, and waste-pipe leading into pit filled with tin cans and broken brick.

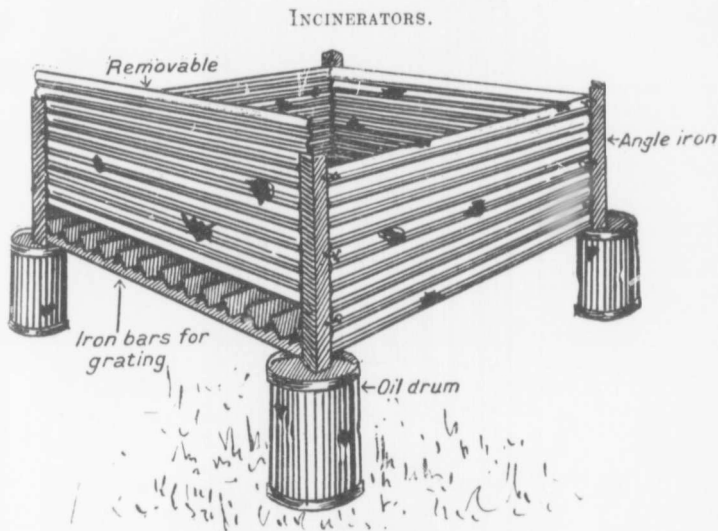

FIG. 49.

FIG. 49.—Made from four damaged sheets of corrugated iron. Three of the sheets are fastened to iron supports by wire loops. One sheet removable for cleaning. The supports can be set on four damaged oil drums filled with clay.

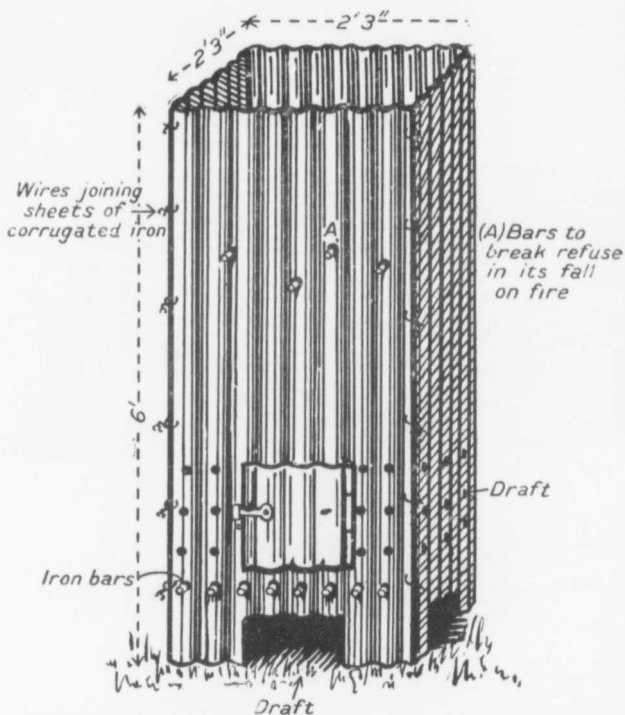

FIG. 50.

FIG. 50.—Made from four sheets of corrugated iron fastened by wire loops. The iron bars used for grating can be pulled out to clear fire. The four irregular-placed bars break the refuse in its fall on the fire. Air inlets are made on four sides above grating. The lower drafts can be used for scraping out ashes. Tin cans too large to fall through grate can be taken out at door. This type was suggested by XVII Corps.

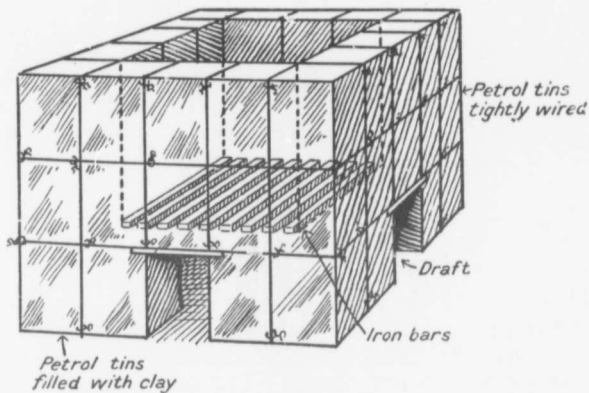

FIG. 51.

FIG. 51.—Made from biscuit or petrol tins filled with clay and wired together. Grating made from any available iron bars. The air inlets can be used for scraping out ashes and tin cans.

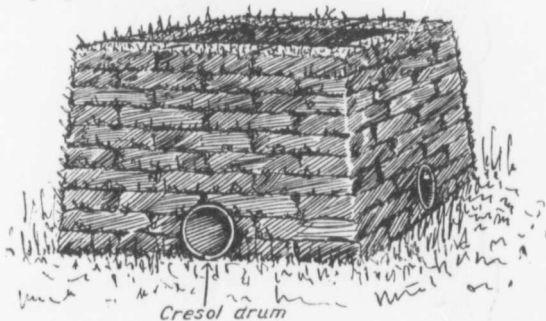

FIG. 52.

FIG. 52.—Made from turf sods with cresol drums used for air inlets. Old iron bars of any kind will serve as grating.

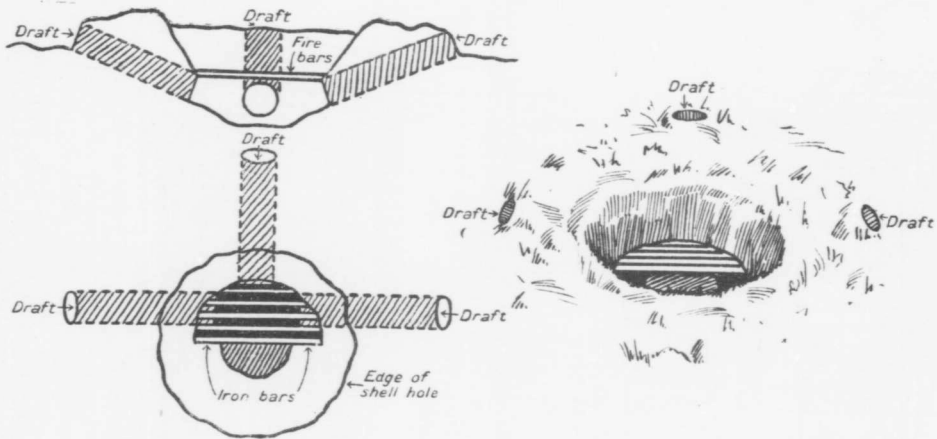

FIG. 53.

FIG. 53.—A simple incinerator suitable for forward areas and constructed in a shell hole. The grating may be made from any available iron bars or a perforated sheet of corrugated iron. To secure a draught of air under and through the material to be burned old oil drums can be set in ground from the bottom of the trenches to the base of the shell hole. The idea of this type of incinerator is that in advanced areas or areas under observation the smoke is dissipated much better than in the ordinary type.

MANURE INCINERATORS.

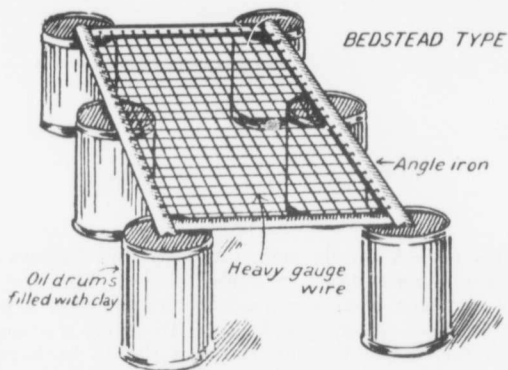

FIG. 54.

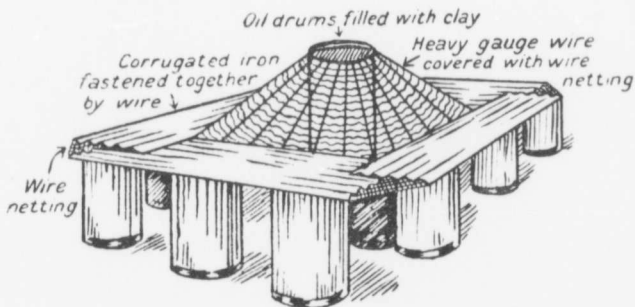

FIG. 55.

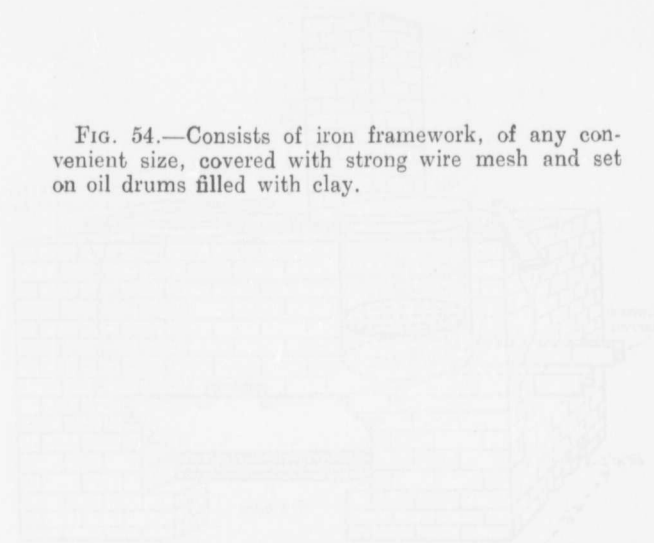

FIG. 54.—Consists of iron framework, of any convenient size, covered with strong wire mesh and set on oil drums filled with clay.

FIG. 55.—Heavy wires are fastened to oil drums and corrugated iron and covered with strong wire mesh. The sheets of corrugated iron are supported by damaged oil drums filled with earth.

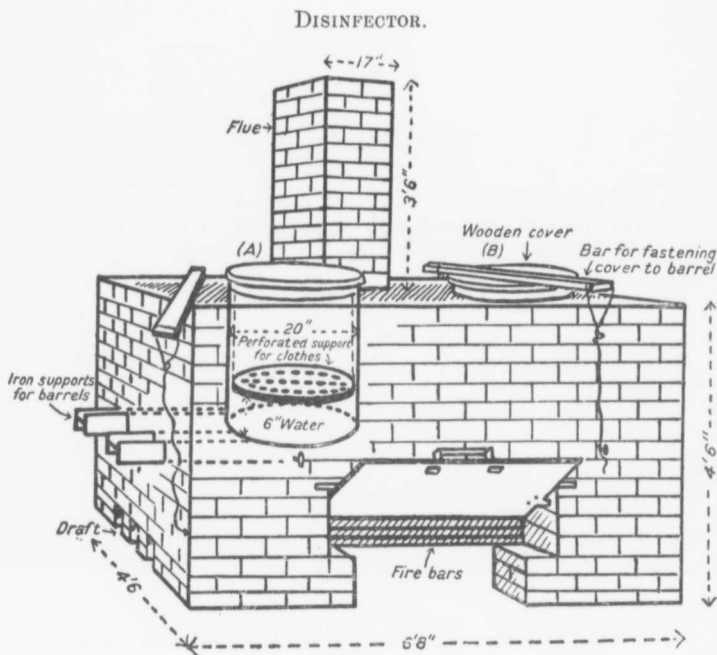

FIG. 56.

FIG. 56.—This type is capable of disinfecting 300 blankets per day. (A) and (B) are two iron barrels each containing 6 in. of water, and a smaller wooden barrel perforated at the bottom. The lids are made of wood with a layer of felt making the joint steam-tight. This design was suggested by 92nd British Field Ambulance.

MEASURE FOR CHLORINATING SMALL QUANTITIES OF WATER.

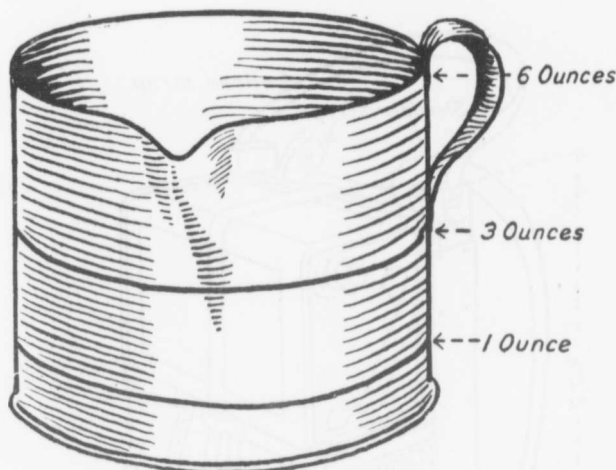

FIG. 57.

FIG. 57.—The quantity of bleaching powder required for 110 gallons is ascertained. If one scoop is found to be sufficient for the water in question, then one scoop of bleaching powder is added to a two-gallon petrol tin. This furnishes the concentrated solution, and it is worked out that 6 oz. of this solution is the required quantity for chlorinating a two-gallon petrol tin, 9 oz. for a dixie, and 1 oz. for a water-bottle. If it is found that two scoops of bleaching powder are required for the water, then two scoops are needed in preparing the concentrated solution. These measures can be made by sanitary sections or supply columns, and should be distributed to water personnel of units,

WATER CARRIER.

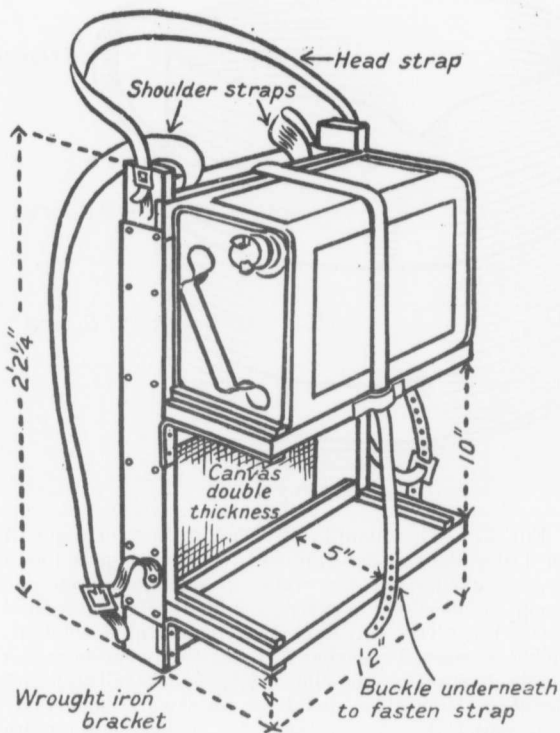

FIG. 58.

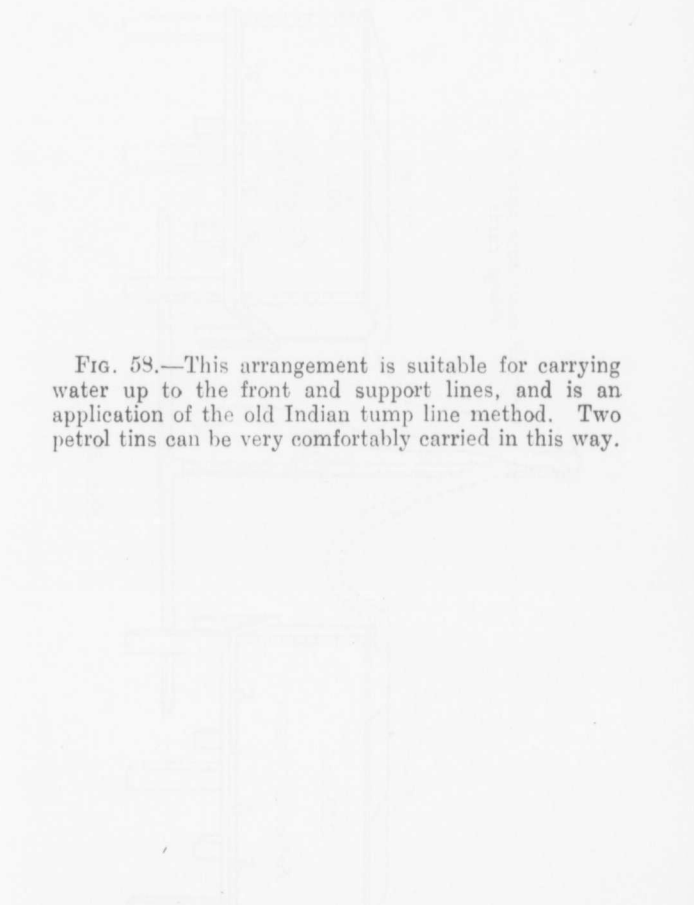

FIG. 58.—This arrangement is suitable for carrying water up to the front and support lines, and is an application of the old Indian tump line method. Two petrol tins can be very comfortably carried in this way.

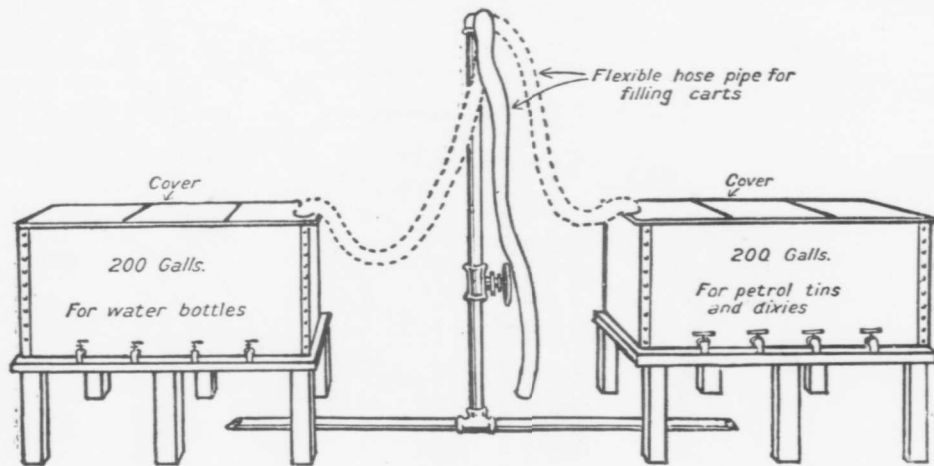

FIG. 59.



FIG. 59.—This sketch shows a convenient arrangement for water-filling points. There should be two tanks at every point, so that chlorinated water is always available. These tanks should be fitted with taps to fill dixies and water-bottles, and should be provided with dust-proof covers. There should always be a flexible rubber pipe to fill carts.

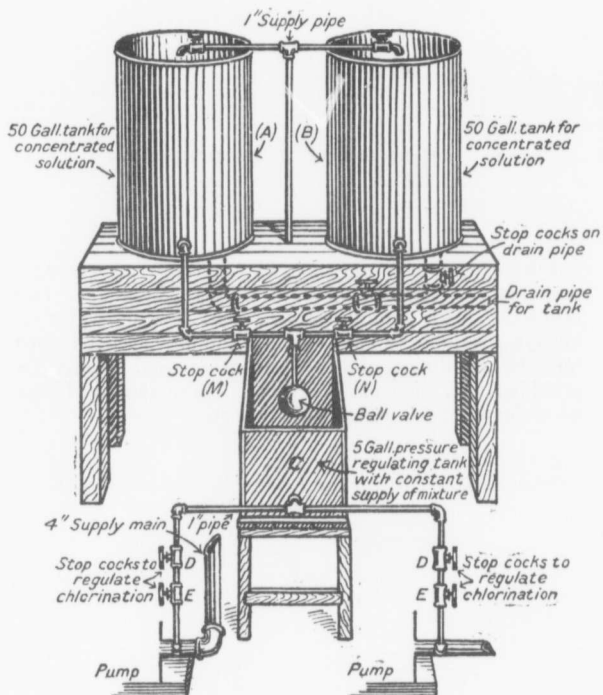

FIG. 60.

FIG. 60.—This is a simple and efficient method and can readily be introduced at all pumping stations, and ensures a constant supply of chlorinated water. It can very quickly be installed—in two or three days. The utensils required are few, and as seen from sketch are two fifty-gallon tanks, one small five-gallon tank with ball cock, a quantity of $\frac{1}{2}$ in. and 1 in. piping, and a few two-way cocks. These materials are always available at any R.E. dump. In the sketch there are two tanks "A" and "B," each capable of containing 500 gallons.

In large pumping stations these tanks could be increased in size. The tanks at present in use are galvanized iron, with an inner facing of tar and cement to prevent any galvanic action with zinc on account of concentrated solution of bleaching powder; concrete tanks would be better. At the bottom of each tank is a drain pipe for washing out and cleaning the tank.

When tank "A" is being emptied, stop cock "M" is open and "N" closed. When tank "B" is being emptied *vice versa*. "C" is a five-gallon tank similarly lined. It has a ball valve and acts as a pressure-regulating tank, and always contains a supply of the mixture. The stop cock "D" is for shutting off the supply when one pump only is working. The sketch shows two pumps in action. The stop cocks "E" are "set" so that the required quantity of concentrated solution goes into suction pipe in the required time. Tanks "A" and "B" are used alternately, one being in operation while the other is being filled. The calculated quantity is placed first in a two-gallon petrol tin with the top removed, where it is well mixed with water. The solution is left for thirty minutes, and allowed to mix freely with water entering tank. At the end of thirty minutes the water is allowed to run into regulating tank "C," from which it runs directly into main suction.

The amount of bleaching powder required is calculated as follows: In a particular instance 24,000 gallons of water were pumped per day. As the water needed one scoop, or 30 grains per 110 gallons, the total amount indicated per day of ten hours would be 6,545 grains. This is approximately 1 lb. bleaching powder, which is easily emulsified in fifty gallons of water. If fifty gallons will be delivered into the main in one day of ten hours, then five gallons must be delivered into the main per hour, or one pint in one and a half minutes. The cock "E" by experiment is therefore "set," so that the regulating tank "C" is emptied at the rate of one pint per one and a half minutes.

THE END.