

Technical and Bibliographic Notes / Notes techniques et bibliographiques

The Institute has attempted to obtain the best original copy available for scanning. Features of this copy which may be bibliographically unique, which may alter any of the images in the reproduction, or which may significantly change the usual method of scanning are checked below.

L'Institut a numérisé le meilleur exemplaire qu'il lui a été possible de se procurer. Les détails de cet exemplaire qui sont peut-être uniques du point de vue bibliographique, qui peuvent modifier une image reproduite, ou qui peuvent exiger une modification dans la méthode normale de numérisation sont indiqués ci-dessous.

- | | | | |
|-------------------------------------|---|-------------------------------------|---|
| <input type="checkbox"/> | Coloured covers /
Couverture de couleur | <input type="checkbox"/> | Coloured pages / Pages de couleur |
| <input type="checkbox"/> | Covers damaged /
Couverture endommagée | <input type="checkbox"/> | Pages damaged / Pages endommagées |
| <input type="checkbox"/> | Covers restored and/or laminated /
Couverture restaurée et/ou pelliculée | <input type="checkbox"/> | Pages restored and/or laminated /
Pages restaurées et/ou pelliculées |
| <input type="checkbox"/> | Cover title missing /
Le titre de couverture manque | <input checked="" type="checkbox"/> | Pages discoloured, stained or foxed/
Pages décolorées, tachetées ou piquées |
| <input type="checkbox"/> | Coloured maps /
Cartes géographiques en couleur | <input type="checkbox"/> | Pages detached / Pages détachées |
| <input type="checkbox"/> | Coloured ink (i.e. other than blue or black) /
Encre de couleur (i.e. autre que bleue ou noire) | <input checked="" type="checkbox"/> | Showthrough / Transparence |
| <input type="checkbox"/> | Coloured plates and/or illustrations /
Planches et/ou illustrations en couleur | <input checked="" type="checkbox"/> | Quality of print varies /
Qualité inégale de l'impression |
| <input checked="" type="checkbox"/> | Bound with other material /
Relié avec d'autres documents | <input type="checkbox"/> | Includes supplementary materials /
Comprend du matériel supplémentaire |
| <input type="checkbox"/> | Only edition available /
Seule édition disponible | <input type="checkbox"/> | Blank leaves added during restorations may
appear within the text. Whenever possible, these
have been omitted from scanning / Il se peut que
certaines pages blanches ajoutées lors d'une
restauration apparaissent dans le texte, mais,
lorsque cela était possible, ces pages n'ont pas
été numérisées. |
| <input type="checkbox"/> | Tight binding may cause shadows or distortion
along interior margin / La reliure serrée peut
causer de l'ombre ou de la distorsion le long de la
marge intérieure. | | |
| <input checked="" type="checkbox"/> | Additional comments /
Commentaires supplémentaires: | | Continuous pagination. |

The Canadian Patent Office

RECORD



Vol. XXV.—No. 6.

JUNE 30th, 1897.

Price free by post in Canada and the United States, \$2.00.
SINGLE NUMBERS, - - - 20 Cts

NOTICE.

All solicitors, agents or attorneys who, in circulars or advertisements, or otherwise, refer to the Commissioner or Deputy Commissioner of Patents, or to any other official of the Patent Office, for evidence of their professional standing, do so without authority.

INVENTIONS PATENTED.

NOTE.—Patents are granted for 18 years. The term of years for which the fee has been paid, is given after the date of the patent.

No. 56,050. Preserving Compound.

(Appareil pour préserver les conserves.)

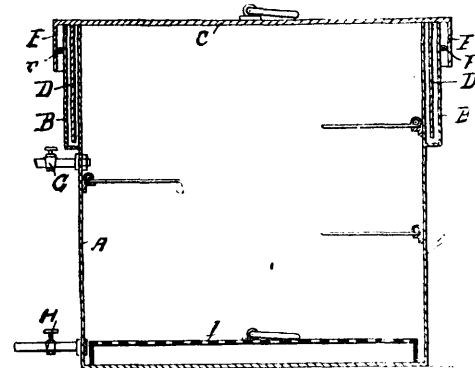

56050

Thomas Henry Lee Bake, London, Middlesex, England, 1st June, 1897; 6 years. (Filed 31st August, 1896.)

Claim.—An apparatus for storing and preserving alimentary and other substances, consisting of a tank having a deep pocket B around its upper edge, a lid having a depending rim D dipping into the said pocket, an outer depending rim E, a packing F interposed between the said rim E and the sides of the pocket B, a cock or valve G to admit gas to the interior of the tank and an outlet cock or valve H, substantially as set forth and for the purposes described.

No. 56,051. Active Material for Secondary Battery Plate.

(Matériel pour plaques de piles secondaires.)

Sigmund Adolf Rosenthal, London, England, 1st June, 1897; 6 years. (Filed 24th October, 1896.)

Claim.—Active material, for application to a lead conductor to form a secondary battery plate, consisting of a finely powdered lead oxide made into a stiff paste by intimate mixture with India-rubber solution, sulphate of ammonium solution, and, if desired, powdered inert material, substantially as described.

No. 56,052. Paper Pulp Screen. (Tamis à pulpe.)

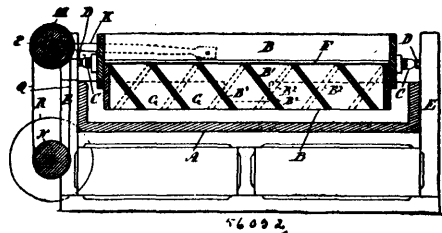

56052

James Bishop and John Painter, both of Hull, Quebec, Canada, 1st May, 1897; 6 years. (Filed 14th December, 1896.)

Claim.—1st. A paper pulp strainer, comprising a bottomless trough divided by a vertical longitudinal partition B¹ and transverse partitions B², on opposite sides thereof, the partitions on one side of the longitudinal partition sloping in an opposite direction to the partitions on the other side, a screen F covering the divisional spaces within the trough, and means for reciprocating the trough longitudinally in a horizontal plane, as set forth. 2nd. A paper pulp strainer, having a bottomless trough divided by partitions into rows of spaces sloping in opposite directions longitudinally of the trough, said rows separated by a vertical partition, a screen covering the divisional spaces, a vat below said trough, and means for reciprocating the trough in a horizontal plane relatively to the sloping spaces, as set forth. 3rd. In a pulp strainer, the combination of a vat to receive the screened pulp, a bottomless trough divided by partitions sloping in opposite directions, a sieve or screen covering the divisional spaces, and means for reciprocating the trough in a horizontal plane relatively to the direction of the slope of the partitions, substantially as set forth.

No. 56,053. Apparatus for Tanning.

(Machine à tanner.)

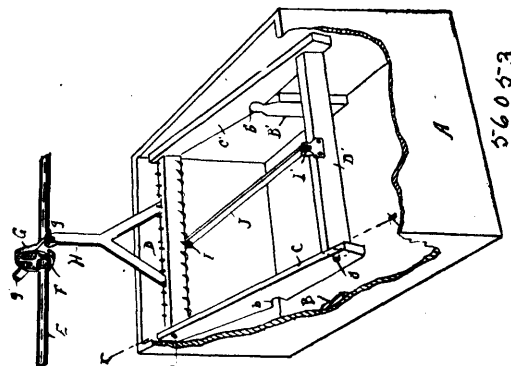

56053

Edwin Du Bois Ralston, Pennsylvania, U.S.A., 1st June, 1897; 6 years. (Filed 22nd March, 1897.)

Claim.—1st. The combination, with a tanning-vat, of a pair of oscillatory bars positioned as shown and each provided with a series of hooks or leather supports above and below its centre of vibration

the upper series of hooks being in different vertical planes from the lower series on each bar for the purpose set forth, a driving mechanism, and connections between the driving mechanism and the bars whereby they are given simultaneous vertical and oscillatory motions, substantially as described. 2nd. The combination, with a tanning-vat, of a frame composed of side bars and cross-bars, the cross-bars being journaled in the side bars, a driving mechanism, a connection between the driving mechanism and frame whereby the frame is given a vertical motion within the vat and the cross-bars of the frame an oscillatory motion, and hooks or leather supports on the cross-bars so located that adjacent sides of leather suspended therefrom are made to move in opposite directions by the oscillations of the cross-bars. 3rd. The combination, with a tanning vat, of a rocking-frame therein composed of side bars pivoted in the vat, and cross-bars journaled in the ends of the side-bars, a connecting-rod between the cross-bars, a driving mechanism, a pitman actuated by the driving mechanism to rock the frame and oscillate the cross-bars, and hooks or leather-supports on the cross-bars so located that adjacent sides of leather suspended therefrom are made to move in opposite directions by the oscillations of the cross-bars.

No. 56,054. Darning Implement.

(Instrument à repriser.)

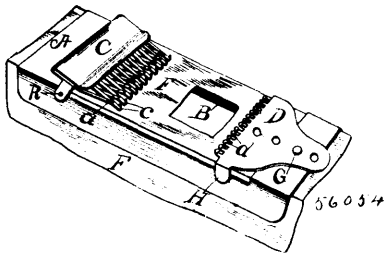

Andrew Edward Smythe, assignee of Mary S. Schafor, both of Chicago, Illinois, U.S.A., 1st June, 1897; 6 years. (Filed 11th March, 1897.)

Claim.—1st.—A darning implement, comprising in combination a table having an opening in its upper surface, a frame fitting over the table having an opening registering with the opening thereof, and adapted to clamp the goods upon the table, a set of stationary hooks carried by the frame at one end of the opening therein, a warp-head adjustably mounted on the frame having a set of hooks arranged at the opposite side of said opening, and a pivoted plate carrying the third set of hooks adapted to work in the interspaces between the stationary set of hooks, and to alternately raise and depress one set of the warp-threads as said plate is rocked upon its pivot, the set of stationary hooks and the set of hooks on the pivoted plate having their points laterally inclined at an angle to their bodies but in opposite directions, substantially as described. 2nd. A darning implement, comprising in combination, a table having an opening in its top, a frame adapted to embrace the sides of the table and to clamp the fabric to be mended thereon, and provided with an opening in its upper surface registering with that of the table, and adjustable warp-head carrying a set of hooks at one end of the table-opening, a set of hooks formed integrally with the frame and projecting into the opening thereof and having their points turned laterally at an angle with their bodies, and a pivoted plate mounted on the frame and having a series of hooks adapted to work in the interspaces between the said set of stationary hooks, and having their points turned laterally at an angle to their bodies but in the opposite direction to the points of the set of stationary hooks with which they co-operate, substantially as and for the purposes described. 3rd. A darning implement, comprising in combination, a table composed of sheet metal having an opening in its body, a skeleton frame also composed of sheet metal, and having flanged sides adapted to embrace the sides of the table, and having an opening adapted to register with the opening of the table, and a series of hooks formed integrally with the frame and projecting into the plane of said opening, a warp-head mounted to slide upon the frame at the opposite end of said opening, and having a series of apertures therein, a hook or lug upon said frame adapted to engage the apertures and providing a fastening for the warp-head in the adjusted position, and a plate formed of sheet metal doubled upon itself pivoted upon the frame and having integrally formed therewith a series of hooks to engage one set of the warp-threads and adapted by its oscillation to carry said set of warp-threads alternately above and below the warp-threads carried by the stationary hooks, substantially as and for the purposes described.

No. 56,055. Combined Fire Escape and Ladder.

(Sauveteur d'incendie et échelle combinés.)

Michael Moss, Montreal, Quebec, Canada, 1st June, 1897; 6 years. (Filed 27th March, 1897.)

Claim.—1st. A fire apparatus consisting of a carrier frame or vehicle, a series of oblong sections carried by said carrier frames and set one within the other, a series of sheaves mounted at the top and

bottom of the ends of both sides of all of said sections excepting the inner section, one or more drums carried by said carrier frame at

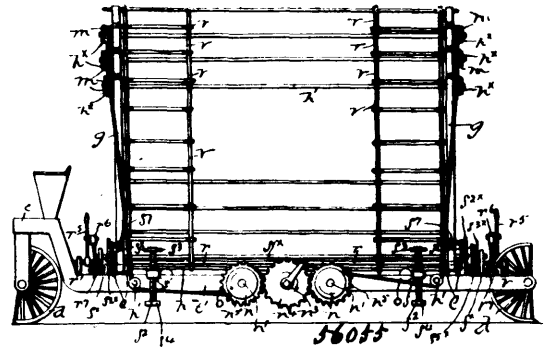

each side thereof, ropes connected to the bottom of said inner section and taken over and under the sheaves mounted respectively at the top and bottom of said sections, the free ends of said ropes being connected to said drum, and means for simultaneously rotating said drums, for the purpose set forth. 2nd. A fire apparatus consisting of a carrier frame or vehicle, a series of oblong sections carried by said carrier frame and set one within the other, a series of sheaves mounted at the top and bottom of the ends of both sides of all of said sections excepting the inner section, one or more drums carried by said carrier frame at each side thereof, ropes connected to the bottom of said inner section and taken over and under the sheaves mounted respectively at the top and bottom of said sections, the free ends of said ropes being connected to said drums, means for simultaneously rotating said drums and a series of draw-bridges carried by said sections and adapted to be extended laterally therefrom, for the purpose set forth. 3rd. A fire apparatus consisting of a carrier frame or vehicle, a series of oblong sections carried by said carrier frames and set one within the other, a series of sheaves mounted at the top and bottom of the ends of both sides of all of said sections excepting the inner section one or more drums carried by said carrier frame at each side thereof, ropes connected to the bottom of said inner section and taken over and under the sheaves mounted respectively at the top and bottom of said sections, the free ends of said ropes being connected to said drums, means for simultaneously rotating said drums, and means for locking said sections, excepting the inner section against vertical movement, for the purpose set forth. 4th. A fire apparatus consisting of a carrier frame or vehicle, a series of oblong sections carried by said carrier frame and set one within the other, a series of sheaves mounted at the top and bottom of the ends of both sides of all of said sections excepting the inner section, one or more drums carried by said carrier frame at each side thereof, ropes connected to the bottom of said inner section and taken over and under the sheaves mounted respectively at the top and bottom of the sections, the free ends of said ropes being connected to said drums and means for simultaneously rotating said drums, a series of ladders carried on each side of said sections and adjacent to each end thereof, for the purpose set forth. 5th. A fire apparatus consisting of a carrier frame or vehicle, a series of oblong sections carried by said carrier frame and set one within the other, a series of sheaves mounted at the top and bottom of the ends of both sides of all of said sections excepting the inner section one or more drums carried by said carrier frame at each side thereof, ropes connected to the bottom of said inner section and taken over and under the sheaves mounted respectively at the top and bottom of said sections, the free ends of said ropes being connected to said drums, means for simultaneously rotating said drums and means for tilting said sections, means for retaining said apparatus against overbalancing when said sections are tilted, for the purpose set forth. 6th. In combination with a vehicle having an extensible structure pivotally mounted thereon, a shaft located at one side of said vehicle and extending longitudinally thereof, a pair of pinions mounted upon said shaft near the ends thereof, a pair of rods pivotally connected at one end to said extensible structure at the opposite side thereof to that at which said shaft is mounted, the lower ends of said rods being made in the form of racks and said racks being adapted to engage said pinions, and ratchet and pawl mechanism for rotating said shaft for the purpose of tilting said extensible structure to one side or the other, a pair of extensible rods carried by said vehicle and adapted to be extended laterally thereof said extensible rods having vertical screw-threaded openings in the ends thereof and vertical screw-threaded rods adapted to take through said openings and bear upon the ground for the purpose of retaining said structure against overbalancing, as set forth. 7th. In combination with a carrier frame, an extensible structure consisting of a series of sections adapted to inclose one another, one, the inner, of said sections being composed of two oblong frames having a platform extending between and connected to their top and bottom sides, respectively, the outer section being composed of two oblong frames pivotally connected at their bottom sides to said carrier frame, and the sections intermediate of said inner and outer sec-

tions being each composed of two oblong frames having a platform extending between and connected to the bottom sides thereof, means for extending said structure, a shaft extending longitudinally from end to end of said carrier frame, a disc mounted upon each end of said shaft, four locking pins or bolts, adapted to take through perforations in said sections at each end of each frame thereof, link connections between said pins or bolts and said discs, one of said discs having its periphery gear-teethed, a second shaft mounted at right angles to said first mentioned shaft, a worm mounted upon one end of said second shaft and adapted to be engaged by said gear-toothed disc, and a crank handle mounted upon the opposite end of said second shaft, for the purpose of rotating the discs, substantially as set forth.

No. 56,056. Smoke Consumer. (Appareil fumivore.)

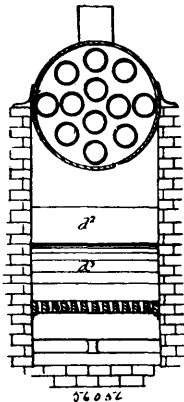

Charles Moisan, Montreal, Quebec, Canada, 1st June, 1897; 6 years. (Filed 6th April, 1897.)

Claim.—1st. In combination with the fire of a smoke consumer, an air supply adapted to be forced across one side of said fire and around one end to the other side thereof, to be drawn through said fire by the said passage of the air across the first mentioned side of same, means for forcing the air in said circuit, and a communication between the space at the side of the fire across which said air supply is forced and the chimney connection, for the purpose set forth. 2nd. In combination with the fire of a smoke consumer, an air supply adapted to be forced across one side of said fire and around one end to the other side thereof, to be drawn through said fire by the said passage of the air across the first mentioned side of same, means for forcing the air in said circuit consisting of live steam and means for injecting same, and a communication between the space at the side of the fire across which said air supply is forced and the chimney connection, for the purpose set forth. 3rd. A furnace comprising a fire chamber, a heat retaining chamber and communicating passage or passages between said heat retaining chamber and the chimney connection, for the purpose set forth. 4th. A furnace comprising a fire chamber, a heat retaining chamber and communicating passages between said heat retaining chamber and the chimney connection, the ends of said passages adjacent to said chimney connection being inclined towards one another, for the purpose set forth. 5th. In a smoke consuming furnace, the combination of an inclosing chamber the front wall whereof is adapted to support the forward end of a fire grate, a bridge adapted to extend transversally from side to side of said chamber and from the floor to within a short distance of the top thereof, said bridge being adapted to support the rear end of said grate, a flue formed in said bridge and extending from a point above said grate to a point below same; an air supply directed towards the upper end of said flue, means for forcing said air supply into said flue, and a communicating passage or passages between the space above said bridge and the open air, for the purpose set forth. 6th. In a smoke consuming furnace, the combination of an inclosing chamber the front wall whereof is adapted to support the forward end of a fire grate, a bridge adapted to extend transversely from side to side of said chamber and from the floor to within a short distance of the top thereof, said bridge being adapted to support the rear end of said grate, a flue formed in said bridge and extending from a point above said grate to a point below same, an air supply directed towards the upper end of said flue, means for forcing said air supply into said flue consisting of a live steam supply and means for injecting same, and a communicating passage or passages between the space above said bridge and the open air, for the purpose set forth. 7th. A smoke consuming furnace, the combination of an inclosing chamber, a bridge located transversely thereof and extending from side to side and from the bottom to within a short distance of the top thereof, a vertical transverse partition located intermediate of

said bridge and the rear of said chamber, a communication between the space or sub-chamber thus formed at the rear of said partition and the open air, a pair of horizontal flues extending through said partition and inclined towards one another at their rear ends, said flues affecting a communication between the said sub-chamber and the sub-chamber between said partition and the bridge, a grate located between said bridge and the front wall of the inclosing chamber and supported by said wall and bridge, a curved flue formed in said bridge and extended from a point above said grate to a point below same, a combined air and live steam supply directed towards the upper end of said flue, and means for forcing said combined air and live steam into said upper end of the flue, for the purpose set forth. 8th. A smoke consuming furnace, the combination of an inclosing chamber, a bridge located transversely thereof and extending from side to side and from the bottom to within a short distance of the top thereof, a vertical transverse partition located intermediate of said bridge and the rear of said chamber, a communication between the space or sub-chamber thus formed at the rear of said partition and the open air, a pair of horizontal flues extending through said partition and inclined towards one another at their rear ends, said flues affecting a communication between the said sub-chamber and the sub-chamber between said partition and the bridge, a grate located between said bridge and the front wall of the inclosing chamber and supported by said wall and bridge, a curved flue formed in said bridge and extended from a point along said grate to a point below same, a combined air and live steam supply directed towards the upper end of said flue, and means for forcing said combined air and live steam into said upper end of the flue, said means consisting of an injector having the nozzle thereof projecting inwardly through said front wall of the inclosing chamber and diverted towards the upper end of said flue, the rear end of said nozzle having a damper controlled opening to the open air, and a live steam supply to said nozzle, for the purpose set forth. 9th. A smoke consuming furnace, the combination of an inclosing chamber, a bridge located transversely thereof and extending from side to side and from the bottom to within a short distance of the top thereof, a vertical transverse partition located intermediate of said bridge and the rear of said chamber, a communication between the space or sub-chamber thus formed at the rear of said partition, and the open air, a pair of horizontal flues extending through said partition and inclined towards one another at their ends, said flues effecting a communication between the said sub-chamber and the sub-chamber between said partition and the bridge, a grate located between said bridge and the front wall of the inclosing chamber and supported by said wall and bridge, a curved flue formed in said bridge and extended from a point along said grate to a point below same, a combined air and live steam supply directed towards the upper end of said flue, and means for forcing said combined air and live steam into said upper end of the flue, said means consisting of an injector having the nozzle thereof projecting inwardly through said front wall of the inclosing chamber and directed towards the upper end of said flue, the inner end of said nozzle being horizontally flared or extended in width to present an oval or oblong opening, the rear end of said nozzle having a damper controlled opening to the open air, and a live steam supply to said nozzle, for the purpose set forth. 10th. A smoke consuming furnace, the combination of an inclosing chamber, a bridge located transversely thereof and extending from side to side and from the bottom to within a short distance of the top thereof, a vertical transverse partition located intermediate of said bridge and the rear of said chamber, a communication between the space or sub-chamber thus formed at the rear of said partition, and the open air, a pair of horizontal flues extending through said partition and inclined towards one another at their rear ends, said flues effecting a communication between the said sub-chamber and the sub-chamber between said partition and the bridge, a grate located between said bridge and the front wall of the inclosing chamber and supported by said wall and bridge, a curved flue formed in said bridge and extended from a point along said grate to a point below same, a combined air and live steam supply directed towards the upper end of said flue, and means for forcing said combined air and live steam into said upper end of the flue, said means consisting of an injector having the nozzle thereof projecting inwardly through said front wall of the inclosing chamber and directed towards the upper end of said flue, the rear end of said nozzle being connected to the apex of a conical section having two openings therein and a smaller opening intermediate of said openings, a steam injector located in said intermediate opening and in line with the centre of said nozzle, a valve controlled steam supply to said steam injector, the opening below said intermediate opening being provided with a damper and the opening above said intermediate opening being provided with a rotary device, for the purpose set forth. 11th. A combined air and live steam injector comprising a nozzle of tubular form, the rear end of said nozzle having a damper controlled opening to the open air, and a live steam supply to said nozzle, for the purpose set forth. 12th. A combined air and live steam injector comprising a nozzle of tubular form, the rear end of said nozzle being connected to the apex of a conical section having two openings therein and a smaller opening intermediate of said openings, a steam injector located in said intermediate opening and in line with the centre of said nozzle, a valve controlled steam supply to said steam injector, the opening below said intermediate opening being provided with a damper and the opening above said intermediate opening being provided with a rotary device, for the purpose set forth.

No. 56,057. Bridge. (Pont.)

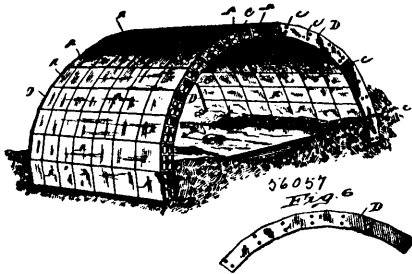

Benjamin Lindsay Blair, Indianapolis, Indiana, U.S.A., 1st June, 1897; 6 years. (Filed 13th April, 1896.)

Claim.—1st. A bridge composed of hollow clay blocks, the ends whereof at those portions exposed to receive water are filled with concrete, substantially as and for the purposes set forth. 2nd. A bridge composed of hollow blocks, the ends being filled with concrete imbedded therein, and protecting plates secured to the ends of the bridge by means of bolts, substantially as set forth. 3rd. The combination, in a bridge, of hollow clay blocks forming the arch, concrete filling the ends of those of said blocks into which by their situation water is apt to enter, bolts imbedded in said concretes, and metal plates secured to said bolts and protecting the ends of the arch, the whole being arranged and operating, substantially as set forth. 4th. As a new article of manufacture, hollow burned clay blocks for building bridges, the openings wherein are filled with concrete after the blocks are made, whereby water is excluded therefrom, substantially as set forth.

No. 56,058. Hinge. (Penture.)

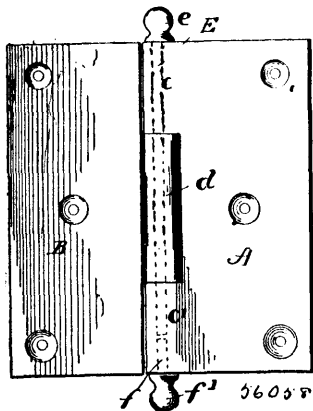

Charles Hammon Davis, Glouster, Ohio, U.S.A., 1st June, 1897; 6 years. (Filed 15th April, 1897.)

Claim.—1st. A hinge provided with a pintle fitted loosely therein, whereby the leaves may be separated by simply pulling out the pin, substantially as described. 2nd. A hinge having two leaves formed with engaging knuckles, and a pin fitting loosely in said knuckles, whereby it may be readily removed, substantially as described. 3rd. The combination with a door-jamb and door, of a hinge having two leaves connecting said jamb and door and provided with engaging knuckles, a false pintle plug rigidly fitted from below in one knuckle, and a pintle having a head and fitting loosely in said knuckles, substantially as described.

No. 56,059. Skirt Binding. (Bordure de jupes.)

Lillian Francis Doty, Chicago, Illinois, U.S.A., 1st June, 1897; 6 years. (Filed 15th April, 1897.)

Claim.—1st. A skirt binding of chamois skin, substantially as described. 2nd. A skirt binding formed of a piece of upwardly doubled chamois skin, substantially as described. 3rd. The combination with a skirt having its lower edge doubled back, of a skirt

binding consisting of an upwardly doubled strip of chamois skin sewed to the doubled edge of the skirt. 4th. The combination with

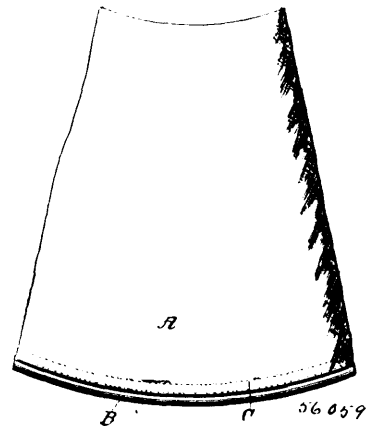

a skirt having its lower edge doubled back, of a skirt binding consisting of an upwardly doubled strip of chamois skin sewed to the doubled edge of the skirt, and a supplemental binding having a doubled edge secured to the chamois skin.

No. 56,060. Wheat Steamer.

(Appareil pour passer le blé à la vapeur.)

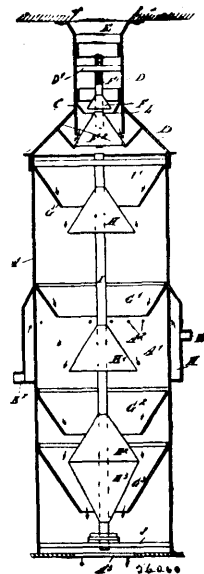

William Leon Mathews, Marlette, Michigan, U.S.A., 1st June, 1897; 6 years. (Filed 15th April, 1897.)

Claim.—1st. A wheat steamer, comprising a casing having a cap supporting a central feed pipe, a regulating pipe mounted to turn on said feed pipe and provided with a cross-piece, a non-rotary screw-threaded rod engaging in a tapped opening in said cross-piece, a regulating cone on the said rod, a series of annular hoppers arranged one above another in said casing, a deflecting cone below and for each hopper, and an inverted cone in the lower hopper of the series to prevent clogging, substantially as shown and described. 2nd. A wheat steamer, comprising a casing having a cap supporting a central feed pipe, a regulating pipe mounted to turn on said feed pipe and provided with a cross-piece, a screw rod screwing in said cross-piece, means for preventing a rotary movement of the screw rod, and a cone fitting into the said feed pipe and secured to said rod, to permit of regulating the feed opening upon turning said regulating pipe, substantially as shown and described. 3rd. A

wheat steamer, comprising a casing having a cap supporting a central feed pipe, a regulating pipe mounted to turn on said feed pipe and provided with a cross-piece, a screw rod screwing in said cross-piece, a cone fitting into the said feed pipe and secured to said rod, to permit of regulating the feed opening upon turning said regulating pipe, and a fixed guide in which the said rod is fitted to slide but prevented from turning, substantially as shown and described. 4th. The herein described apparatus, comprising a casing having a central feed pipe, a hopper secured within the said pipe, a vertically movable cone arranged adjacent to said hopper, and means for adjusting the cone, substantially as described. 5th. The herein described apparatus, comprising a casing having a central feed pipe, a hopper secured within the said pipe, screw rod arranged in the feed pipe and carrying a cone adjacent to the hopper, a rotatable part engaging the screw-thread, and a deflecting cone arranged below the hopper and having an angular opening to receive the screw-thread and hold it against turning, substantially as described.

No. 56,061. Check Hook. (Crochet de sellette.)

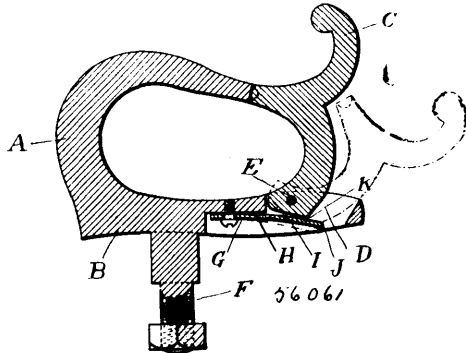

Henry H. Whitney, Deering, Maine, U.S.A., 1st June, 1897; 6 years. (Filed 17th April, 1897.)

Claim.—1st. In a check-rein hook, a base adapted to be secured to a saddle tree, a hook on said base, a closure bar pivotally secured to said base and adapted, in its normal position, to engage the end of said hook but capable of being swung out of engagement therewith, and a spring adapted to engage and hold said closure bar yieldingly, both when in engagement with said hook and when wide open, substantially as and for the purposes set forth. 2nd. In a check-rein hook, in combination, a base adapted to be secured to a saddle tree and having a downwardly extending portion at the front thereof, a socket in the top of said base, a hook on said base, a closure bar pivoted in said socket, said closure bar being provided on its lower extremity with flattened edges, a leaf spring mounted in said socket and adapted with its free end to bear against the flattened edges of said closure bar, whereby the said bar may be held in open or closed contact with the hook, substantially as and for the purpose set forth.

No. 56,062. Nut Lock. (Arrête-écrou.)

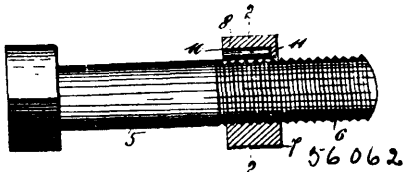

Oliver Isaac Davis, Westville, Connecticut, U.S.A., 1st June, 1897; 6 years. (Filed 17th April, 1897.)

Claim.—1st. In a nut lock, a nut provided with the usual transverse screw-threaded bore, in one side of which is formed a transverse groove, the outer wall of which is inclined in a direction opposite to that in which the nut must be turned in order to remove it, and a key plug which is placed in said groove, substantially as shown and described. 2nd. A rod, shaft, bolt, or spindle provided with a screw thread, a screw-threaded nut mounted thereon, said screw-threaded nut being provided in one side of the central screw-threaded bore thereof with a transverse groove, the outer wall of which is inclined in a direction opposite to that in which said nut is turned in order to remove it, and a key plug which is placed in said groove, substantially as shown and described. 3rd. In a nut lock, a nut provided with the usual screw-threaded bore, in one side of which is formed a transverse groove, the outer wall of which is inclined, and a key plug which is placed in said groove, and means for operating said plug when in position, substantially as shown and described. 4th. In a nut lock, a rod, bolt or spindle and a nut which is provided with a groove which is formed transversely of the threads thereof, the outer wall of said groove being inclined in a direction opposite to that in which said nut is turned in order to

remove it, and a key plug which is placed in said groove, substantially as shown and described. 5th. In a nut lock, a nut which is provided with a groove which is formed transversely of the threads thereof, the outer wall of said groove being inclined in a direction opposite to that in which said nut is turned in order to remove it, and a key plug which is placed in said groove and adapted to operate on the thread of a spindle bolt or rod, and means for preventing the key plug from operating, substantially as shown and described.

No. 56,063. Safety Brake for Elevator Cars.

(Frein de sûreté pour élévateurs.)

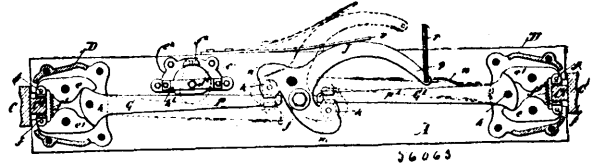

Thomas Jefferson Vail, Hartford, Connecticut, assignee of Edward Collins, New York, State of New York, both in the U.S.A., 1st June, 1897; 6 years. (Filed 20th April, 1897.)

Claim.—1st. In a safety brake for elevators, in combination with a running rope *r* controlled by a governor, trip and clamp mechanism, a compound lever system comprising lever *J* having long arm *q* and short arms as *m*, *n*, levers *G* (*G*¹), clamping levers *e-e*¹ and pivoted brake shoes *f-f* acting upon the guide runners *C*¹ *C*¹ to clamp the same when operated by unusual stress upon the rope *r*, substantially as specified. 2nd. In a safety brake for elevators, the head blocks *D* *D*, the clamping levers *e-e*¹ pivoted within the said head blocks, brake shoes *f-f* pivoted to the said clamping levers, one on each side of the guide runners, lever *J* having arms *m*, *n* and *g*, levers *G* (*G*¹) pivoted within the head blocks having short arms acting in opposite directions on the arms of the clamping levers *e-e*¹, long arms *p-p*¹ acted on in opposite directions by the short arms *m-n* of the lever *J* and rope *r*, substantially as specified. 3rd. In a safety brake for elevators, a pair of clamping levers as *e-e*¹ pivoted in head blocks *D*-*D*, carrying brake shoes *f-f* pivoted thereto, which engage with the guide runner, and compound levers acting upon the said clamping levers to compress the brake shoes through the medium of a rope cord or chain *r* when an unusual strain occurs upon the latter through the accelerated motion of the car downward, substantially as specified. 4th. In a safety brake for elevators, the combination of head block *D*, adjustable guide plates *S* held to webs *s*, clamping levers *e-e*¹, carrying pivoted brake shoes *f-f*, lever *G* acting upon the said clamping levers simultaneously to compress the brake shoes, and pivoted lever *J* having short arm *m* acting on the long arm of lever *G*, and long arm *q* acted upon by the rope or chain *r* when strains occurs in the said rope or chain, all substantially as specified. 5th. In a safety brake for elevators, the combination of the head block *D*, guide plates *S*, clamping levers *e-e*¹, brake shoes *f-f*, lever *G* acting upon the said clamping levers simultaneously to operate the brake shoes, lever *J* having arm *n* acting upon long arm lever *G*, and arm *q* acted upon by the rope or chain *r* when strain occurs in the said rope or chain, substantially as specified. 6th. In a safety brake for elevators, the clamping levers *e-e*¹ pivoted in head blocks *D*, carrying pivoted brake shoes *f-f*, which engage with the guide runners, in combination with double acting lever *G*, operating simultaneously in opposite directions on the clamping levers, lever *J* and rope *r*, substantially as specified. 7th. In a safety brake for elevators, the combination with the main operating mechanism of means operating synchronously therewith, whereby the brake is maintained in the position assumed after having been either partially or wholly set. 8th. In a safety brake for elevators, the combination with the main operating mechanism of automatically acting cam mechanism acting synchronously therewith to maintain the brake in the position assumed after having been either partially or wholly set. 9th. In a safety brake for elevators, the combination with a clamping lever or jaw actuated by a long lever, said levers being respectively provided with a brake shoe, suitable supports therefor and a main operating lever acting upon said long lever, of cam mechanism operating in appropriate proximity to one of said levers, whereby the various parts are maintained in the position assumed after the brake has been either partially or wholly set. 10th. In a safety brake for elevators, the combination with the main operating mechanism, of an automatically rotated cam *e*¹ acting in synchronism therewith and so arranged in relation thereto as to maintain the brake in the position assumed after it has been either partially or wholly set. 11th. In a safety brake for elevators, the combination with the main operating mechanism, of an automatically rotated cam *e*¹ provided with a plurality of flattened surfaces and acting synchronously therewith, said cam being so arranged in relation to said operating mechanism as to maintain the brake in the position assumed after it has been either partially or wholly set. 12th. In a safety brake for elevators, the combination with the main operating mechanism of the automatically rotated cam *e*¹ so arranged in relation thereto as to maintain the brake in the position assumed after it has been either partially or wholly set, and means whereby the extent of rotation of said cam is limited. 13th. In a safety

brake for elevators, the combination with the main operating mechanism of the automatically rotated cam c^1 acting in synchronism therewith, and having a fin or ridge h^1 adapted by contact with an abutment f^2 to limit the rotation of said cam, said cam being so arranged in relation to said main operating mechanism as to maintain the brake in the position assumed after it has been either partially or wholly set. 14th. In a safety brake for elevators, the combination with the main operating mechanism of the automatically rotated cam c^1 acting in synchronism therewith, and provided with a ridge or fin h^1 adapted to limit the rotation of said cam by contact with an abutment f^2 provided with a guide groove g , said cam being so arranged in relation to said main operating mechanism as to maintain the brake in the position assumed after it has been either partially or wholly set. 15th. In a safety brake for elevators, the combination with the main operating mechanism of the cam c , rigidly mounted upon the shaft a^1 in approximate proximity to said mechanism, said shaft being subjected to an unremitting torsional strain, whereby when said actuating mechanism is put in operation, said cam is rotated synchronously therewith to maintain the various parts in the position assumed after the brake mechanism has been either partially or wholly set. 16th. In a safety brake for elevators, the combination with the main operating mechanism of a cam c^1 rigidly mounted on a shaft a^1 in such proximity to said main operating mechanism as to remain in constant contact therewith, and a coiled spring i operating on said shaft whereby when said main operating mechanism is actuated, said cam is rotated in synchronism therewith. 17th. In a safety brake for elevators, the combination with the main operating mechanism of a cam c^1 automatically rotated, acting synchronously therewith and in such proximity thereto as to prevent the brake from assuming its normal position after it has been either partially or wholly set and means whereby said cam may be so rotated as to allow the various parts to assume such position. 18th. In a safety brake for elevators, the combination with the main operating mechanism of the cam c^1 rigidly mounted upon the shaft a^1 in appropriate proximity to said mechanism, said shaft being subjected to an unremitting torsional strain, whereby when said actuating mechanism is put in operation said cam is rotated synchronously therewith to maintain the various parts in the position assumed after the brake has been either partially or wholly set, said shaft being so constructed and arranged as to be capable of rotation to return the various parts to their normal position. 19th. In a safety brake for elevators, the combination with the main operating mechanism consisting substantially of brake shoes adapted to engage the guide runners and a compound lever system for compressing the same against said runners, of cam mechanism operating in conjunction with one of said levers in said system and in synchronism with the operation of the same to maintain the brake in position assumed after the brake has been either partially or wholly set. 20th. In a safety brake for elevators, the combination with the main operating mechanism consisting substantially of brake shoes adapted to engage the guide runners, and pivoted respectively to a clamping lever jaw acted upon by a long, double acting lever, actuated by the main operating lever, of mechanism applied to one of said levers and acting synchronously with the operation of said main operating lever to maintain the brake in the position assumed after the brake has been either partially or wholly set. 21st. In a safety brake for elevators, the combination with the main operating mechanism consisting substantially of brake shoes adapted to engage the guide runners, and pivoted respectively to a clamping lever or jaw acted upon by a long, double acting lever, actuated by the main operating lever, of a cam c^1 rigidly mounted on a shaft a^1 in such proximity to one of said levers as to remain in constant contact therewith, and a coiled spring i operating on said shaft whereby when said main operating mechanism is actuated, said cam is rotated in synchronism therewith.

No. 46,064. Car Fender. (Défense de chars.)

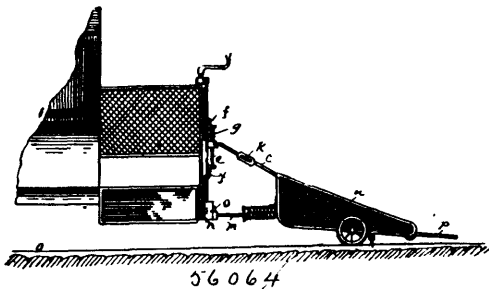

56064

John P. Kane, Dawson, and Samuel O'Neil, Fayette City, both in Pennsylvania, U.S.A., 1st June, 1897; 6 years. (Filed 20th April, 1897.)

Claim.—1st. In a car-fender, the fender proper scoop shape in form, provided with a suitable netting, a supporting rod hinged to the top of the fender, cylinders hinged to the rear of same, a supporting-rod secured to the car and operating in said cylinders, said fender supported by pony-wheels at the side, and provided

with spring-actuated padded arms at the front and means for releasing the spring, substantially as shown and described. 2nd. In a car-fender, the fender proper, cylinders hinged at the rear of said fender, supporting-rods operating in the cylinders, a supporting-rod connected to the top of said fender, and to a sliding collar on a rod attached to the front of the car, said fender carrying spring-arms adapted to engage an object and lift the same on the fender and means for releasing the spring, substantially as shown and described. 3rd. In a car fender, the front rail thereof carrying a semi-circular portion provided with lugs, spring-actuated arms secured to the side rails and adapted to engage the lugs of the semi-circular portion, said fender being supported by pony-wheels and by supporting-rods operating in cylinders secured to the fender, the rear of said rods attached to a bracket on the car, a centre connecting-rod attached to the fender and to a collar operating on a rod secured to the car, substantially as shown and described. 4th. In a car-fender, the fender proper having suitable netting, a semi-circular portion on the front rail of said fender, said portion carrying lugs, spring-actuated arms secured to the side rails, said arms engaging the lugs, cylinders secured to said fender, supporting-rods secured to the car and operating said cylinders, pony-wheels supporting said fenders and a supporting-rod connected to the fender and to a sliding collar and a rod attached to the front of the car, said rod provided with a screw-buckle, substantially as shown and described. 5th. In a car-fender, the fender proper having suitable netting, a semi-circular portion on the front rail of said fender, said portion carrying lugs, spring-actuated arms secured to side rails, said arms engaging the lugs, cylinders secured to said fender, supporting-rods secured to the car and operating said cylinders, pony-wheels supporting said fender, a brush or scraper secured to the fender in front of said pony-wheels and a supporting-rod connected to the fender and to a sliding collar and a rod attached to the front of the car, said rod provided with a screw-buckle, substantially as shown and described.

No. 56,065. Car Coupler. (Attelage de chars.)

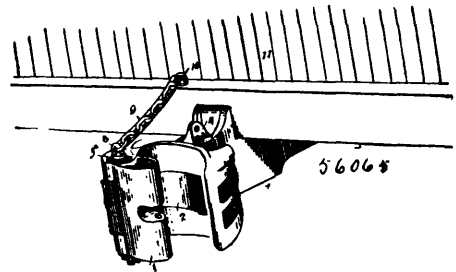

56065

William Constantine Beal, David E. Naxville and William D. Ballantine, all of Fernandina, Florida, U.S.A., 1st June, 1897; 6 years. (Filed 26th April, 1897.)

Claim.—1st. In a car-coupling, the combination of a draw-head, and knuckle pivoted to the same and provided at the end of the arm with an inclined rib or flange having upper and lower inclined edges, a vertical flange arranged on the end of the arm and extending downward from the rear or upper end of the inclined rib, and a vertically-movable locking-pin provided at its front with an inclined recess engage the upper and lower edges of the same, the lower portion of the locking-pin being arranged to engage said vertical flange to limit the outward or opening movement of the knuckle, substantially as described. 2nd. In a car-coupling, the combination of a locking-pin composed of a longitudinal flange $4b$, and a transverse-flange $4a$, arranged at the front or outer edge of the longitudinal flange and provided at its front with an inclined recess 5 , and a vertical recess 7 , extending upward from one end of the inclined recess, a draw-head provided with an opening for the locking-pin and having one of its sides contiguous to and conforming to the configuration of the outer face of the longitudinal flange and the adjacent face of the transverse flange to support the same, and a knuckle provided at the end of its arm with a rib, substantially as described. 3rd. In a car-coupling, the combination of a draw-head, a knuckle pivoted to the same and provided at the end of its arm with an inclined edge and having a notch or seat at the upper or rear end of the same, and a locking-pin supported upon the inclined edge and arranged to engage the seat or notch automatically when the knuckle is open, whereby the knuckle is locked in its open position, substantially as and for the purpose described. 4th. In a car-coupling, the combination of a draw-head, a knuckle pivoted to the same and provided at the end of its arm with an inclined rib or flange, having at its upper end a substantially V-shaped notch or seat, and a locking-pin having an inclined recess forming upper and lower shoulders, the upper shoulder being adapted to rest in the notch or seat of the arm of the knuckle, substantially as described.

No. 56,066. Ice Cream Disher. (Utensil pour crème à la glace.)

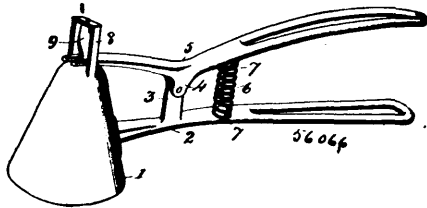

Samuel Francis Rukenbrod, Wilbur H. Appleton and Jones Candel, all of Youngstown, Ohio, U.S.A., 1st June, 1897: 6 years. (Filed 22nd April, 1897.)

Claim.—1st. A device of the character described, comprising a cup, a stationary arm secured thereto, a movable arm, cutting blades rotatable within the cup, said blades adapted to be rotated by the movable arm, and means for returning the movable arm to its normal position, substantially as described. 2nd. A device of the character described, comprising a dipper, an arm secured thereto, a movable arm pivoted to the stationary arm, a spiral shaft suitably journaled and extending within the dipper, said shaft adapted to be engaged by the movable arm and rotated by the movement of the same, cutting blades movable within the dipper to which the end of the shaft is secured, and means for returning the movable arm to its normal position after being rotated, substantially as described. 3rd. A device of the character described, comprising a dipper or cup, a stationary arm secured at one end thereto, a movable arm pivoted to the stationary arm, the inner end of the movable arm being slotted, a spiral shaft suitably journaled and adapted to be engaged by the slotted end of the arm, cutting blades secured to the shaft and rotatable within the cup, said blades adapted to be rotated by the depression of the outer end of the movable arm, and a spring for returning the movable arm to its normal position after being depressed, substantially as described. 4th. A device of the character described, comprising a cup or dipper, a stationary arm secured thereto, a lug raised from said arm, a movable arm having depending lugs between which the lug of the stationary arm extends, whereby the movable arm is pivoted thereto, a bracket upon the inner end of the cup, a spiral shaft journaled at one end in said bracket and extending within said cup, cutting blades secured upon the end of the shaft within the cup, the inner end of the movable arm being slotted and adapted to embrace the spiral shaft, and a spring adapted to normally hold the outer end of the movable arm raised, whereby when said arm is depressed its inner end is raised and the spiral shaft rotated, thus causing the cutting blades to separate the cream contained within the cup from the walls thereof, substantially as described.

No. 56,067. Manufacture of Axle Boxes and Apparatus Therefor. (Fabrication de boîtes à graisse.)

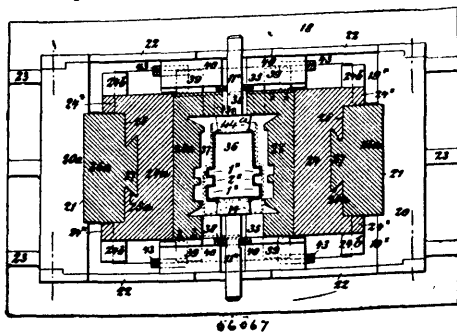

The Fox Solid Pressed Steel Co., Chicago, Illinois, U.S.A., assignee of Samson Fox, Leeds Forge, Leeds, York, England, 1st June, 1897; 6 years. (Filed 23rd April, 1897.)

Claim.—1st. Apparatus for the manufacture of axle-boxes, comprising a rigid or non-expanding collapsible mandrel corresponding to the desired form of axle-box and composed of a core and interlocked segments, a pair of laterally-movable dies provided with studs, weighted levers engaging said studs, vertical supports for said dies, top and bottom dies, and means for laterally compressing a metal tube on said collapsible mandrel, forming the desired axle-grooves in said tube and vertically compressing said tube on the collapsible mandrel between said top and bottom dies, while the tube is held by the laterally-movable dies, substantially as described. 2nd. Apparatus for the manufacture of axle-boxes, comprising a recessed base-plate formed with vertical supports, a pair of laterally-movable dies adapted to slide on said supports and to descend into said hollow base-plate when not carried by said supports, a bottom die carried by said base-plate, a vertically-movable

cap-piece having wedge-shaped extensions adapted to reciprocate said laterally-movable dies, a top die carried by said movable cap-piece, a collapsible mandrel or inner die supported between said lateral and top and bottom dies by said base-plate, studs fixed to said laterally-movable dies, weighted levers pivoted to said cap-piece and adapted to engage said studs, and means for permitting said levers to engage said studs and for disengaging the levers therefrom at the required times, substantially as herein described for the purposes specified. 3rd. Apparatus for the manufacture of axle-boxes, comprising a recessed base-plate formed with vertical supports, a pair of laterally-movable dies adapted to slide on said supports and to descend into said base-plate when not carried by said supports, blocks carrying said dies, and each having its outer end face downwardly inclined, a bottom die carried by said base-plate, a vertically-movable cap piece having wedge-shaped extensions arranged to act against the inclined surfaces of said blocks, a top die carried by said cap-piece, a collapsible mandrel or inner die supported between said lateral and top and bottom dies by said base-plate, projections 29 and 30 carried by said laterally-movable dies, studs fixed to said laterally-movable dies, weighted levers pivoted to said cap-piece formed with recesses adapted to engage said studs and each provided with a pin 45, and fixed rods 43, each having an inclined surface adapted to act against the pin of the corresponding weighted lever, substantially as herein described for the purpose specified.

No. 56,068. Bracket. (Console.)

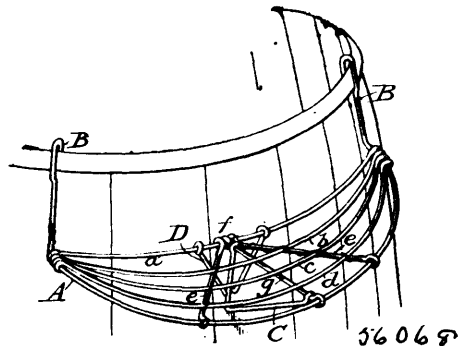

Edward Lenney, Potsdam, New York, U.S.A., 1st June, 1897; 6 years. (Filed 30th May, 1896.)

Claim.—1st. A bracket adapted for attachment to a barrel or other receptacle composed of a series of wires suitably secured together, forming a stand and provided with a series of hooks adapted to be secured to said barrel or other receptacle, and a folding brace piece secured to said bracket, substantially as described. 2nd. A bracket adapted for attachment to a barrel or other receptacle, composed of a series of wires suitably secured together, forming a stand and provided with a series of hooks adapted to be secured to said barrel or other receptacle, and a folding brace piece secured to said bracket, and a pivoted stay wire adapted to engage the brace-piece and prevent lateral movement thereof, substantially as described. 3rd. A bracket composed of a series of curved wires forming a crescent-shaped base and having two or more hooks secured thereto, a central cross-rod, inclined brace rods, and a folding brace-piece pivoted on the central cross-rod, substantially as described. 4th. The herein described bracket comprising an external wire formed with integral hooks, a second external wire secured at each end to the first wire adjacent the hooks, and a series of intermediate curved wires also secured to the first wire adjacent the hooks, and suitable bracing wires, substantially as described.

No. 56,069. Spring Seat for Vehicles. (Siège à ressort pour voitures.)

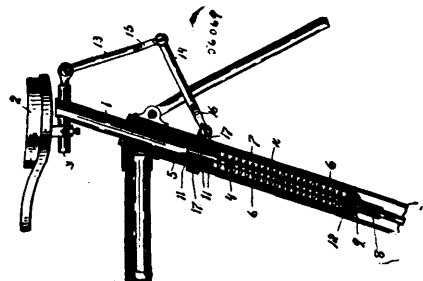

Albert Henry Holland, Buffalo, New York, U.S.A., 1st June, 1897; 6 years. (Filed 24th March, 1897.)

Claim.—A spring-seat for vehicles consisting of a bar carrying the seat, a tubular casing secured within the frame of the vehicle and

within which the seat-bar reciprocates, a spiral spring within the tubular casing, one end of which has a bearing contact with the seat-bar, the other end having a bearing contact with a fixture within the tubular casing, and a flexible keeper having one end secured to the frame of the vehicle and the other end secured to the reciprocating seat-bar.

No. 56,070. Car Buffer. (Tampon de chars.)

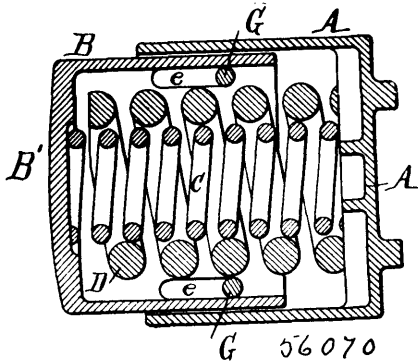

Gould Coupler Company, New York, State of New York, assignee of Willard Fillmore Richards, Buffalo, New York., both in the U.S.A., 1st June, 1897; 6 years. (Filed 26th April, 1897.)

Claim.—1st. The combination with a socket adapted to be secured to the end of a car, of a tubular follower guided in said socket and provided near one side thereof with a longitudinal slot, a stop pin or bolt passing through said socket and the longitudinal slot of the follower, and a buffer spring or springs arranged in said socket and follower, substantially as set forth. 2nd. The combination with a socket adapted to be secured to the end of a car, of a tubular follower guided in said socket and provided in its upper and lower walls and near opposite sides thereof, with longitudinal slots, stop pins passing through said socket and the longitudinal slots of the follower, and a buffer spring or springs arranged in said socket and follower, substantially as set forth.

No. 56,071. Car Coupler. (Attelage de Chars.)

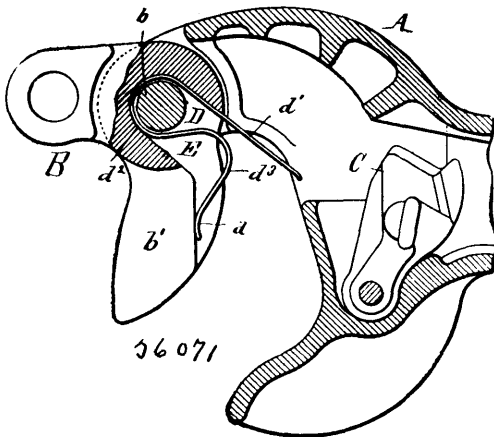

Gould Coupler Co., New York, State of New York, assignee of Willard Fillmore Richards, Buffalo, New York, both in the U.S.A., 1st June, 1897; 6 years. (Filed 26th April, 1897.)

Claim.—1st. The combination with the drawhead, the knuckle or coupling jaw and a lock, of a knuckle opening device interposed between the drawhead and the back of the knuckle and comprising a light primary spring bearing against one of said parts and a secondary auxiliary spring acting upon the other part and arranged to come into action after the primary spring has been strained, substantially as set forth. 2nd. The combination with the drawhead, the knuckle or coupling jaw and a lock, of a knuckle-opening spring consisting of a branch bearing against the drawhead and branch bearing against the knuckle and having a bulge or auxiliary spring, substantially as set forth. 3rd. The combination with the drawhead the knuckle or coupling jaw and a lock, of a knuckle opening spring consisting of an elastic strip extending around the knuckle pivot and having an outer

branch bearing at its free end against the drawhead and an inner branch bearing at its free end against the knuckle and provided with an outward bulge forming an auxiliary spring which is adapted to bear against said outer branch, substantially as set forth.

No. 56,072. Vehicle Wheel. (Roue de voitures.)

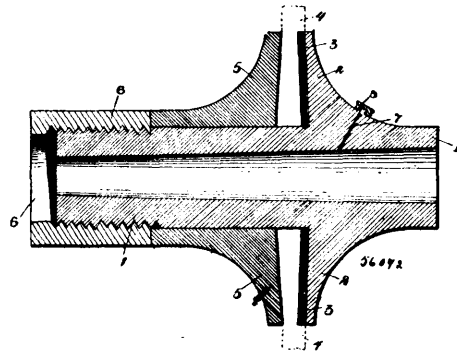

Joseph H. Strong, Berwindsale, Pennsylvania, U.S.A., 2nd June, 1897; 6 years. (Filed April 22nd, 1897.)

Claim.—A hub consisting of three parts, namely a box having an outwardly extending grooved plate, a smooth portion adjacent said plate and a screw-threaded end portion, a movable plate having an opening and an extension and situated upon the smooth portion of said box, and a screw-threaded collar upon the screw-threaded portion of said box bearing against the end of the extension of said movable plate.

No. 56,073. Tobacco Pipes, and Cigar and Cigarette Holders. (Porte-pipes, cigares et cigarettes.)

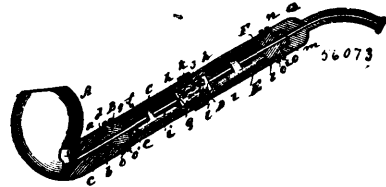

Harry Elmer Gilchrist, Gouverneur, New York, U.S.A., 2nd June, 1897; 6 years. (Filed 15th March, 1897.)

Claim.—1st. A stem for pipes, and cigarette holders, comprising a nicotine chamber C, a saliva chamber E, and a purifying chamber D, said purifying chamber being formed of two parts or sections h, and arranged between and adapted to extend into said first-named chambers and forming a communicating connection there-between, substantially as described. 2nd. A stem for pipes, and cigar and cigarette holders, comprising a nicotine chamber C, in communication with the bore of said stem and a joint B, having an extended tube entering said nicotine chamber, a purifying chamber D, formed of two parts or sections h, one of which is adjustably attached at one end to said nicotine chamber, a saliva chamber E, adjustably secured to the other end of said purifying chamber, a mouth-piece G, and a joint F, having an extended tube connecting said saliva chamber and mouth-piece, substantially as described. 3rd. The combination, with a stem for pipes, cigar, and cigarette holders, made in sections, of a purifying chamber D, consisting of two parts or sections h, adjustably secured together and removably secured between the two sections of the stem and in communication with the bore of said stem and forming a joint therefor, and a suitable absorbent material for said chamber, whereby the chamber may be removed from the stem and its parts separated for cleansing purposes, substantially as described. 4th. The combination, in a stem for pipes, and cigar and cigarette holders, having a nicotine chamber C, and a saliva chamber E therein, of a purifying chamber D, formed of two parts or sections h, adjustably secured together and removably secured within said stem between said nicotine and saliva chambers and communicating therewith, substantially as described.

No. 56,074. Lamp and Coal Oil Stove. (Lampe et poêle à l'huile)

James Norris Luxon, Hamilton, Ontario, Canada, 2nd June, 1897; 6 years. (Filed 22nd April, 1897.)

Claim.—1st. A lamp burner having a wick tube, and a movable flame controlling tube sliding upon the same. 2nd. A lamp burner

having a smooth and even wick tube and a sliding flame controlling tube surrounding said wick tube, and means for moving the outer

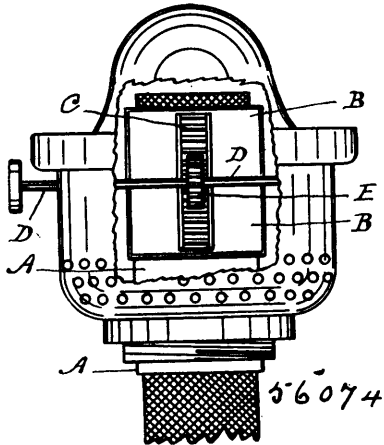

end of the flame controlling tube over the end of the wick tube. 3rd. In a lamp burner, a wick tube, a sliding flame controlling tube, controlling the same, and provided with teeth, and a rotatable shaft having a pinion engaging said teeth.

No. 56,075. Unrefillable Bottle.

(Appareil pour empêcher le remplissage des bouteilles.)

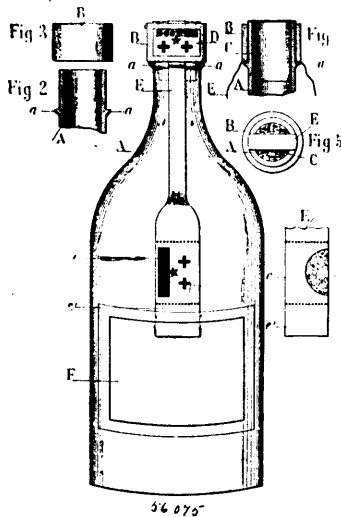

André Braly and Louis Braly, both of Paris, France, 2nd June, 1897; 6 years. (Filed 23rd April, 1897.)

Claim.—An arrangement for preventing the fraudulent refilling of bottles, flasks and other containers, and verifying the origin of their contents consisting in the combination with a bottle or other container of suitable shape, of a transparent ring with an inner label and a safety band passing over the cork inserted between the ring and the bottle, the said band being attached to the bottle and bearing a detachable label having on its visible side the same signs and numbers as the label of the ring, and on the reverse side other signs and characters by which the producer can verify its identity, substantially as described and shown in the drawings.

No. 56,076. Process for the Manufacture of Butter.
(Procédé pour la fabrication du beurre.)

Walter Cole, Toronto, Ontario, Canada, 2nd June, 1897; 6 years. (Filed 23rd April, 1897.)

Claim.—1st. The process of manufacturing butter, which consists in first subjecting the cream to natural lactic fermentation sufficient to coagulate the albuminous sacs of the butter globules, second, producing a rapid alcoholic fermentation in the non-fatty solids of the cream to destroy the viscosity of the cream, and to effect the separation of the butter globules from the remaining elements of

the cream, substantially as herein set forth. 2nd. The process of manufacturing butter, which consists in first subjecting the cream

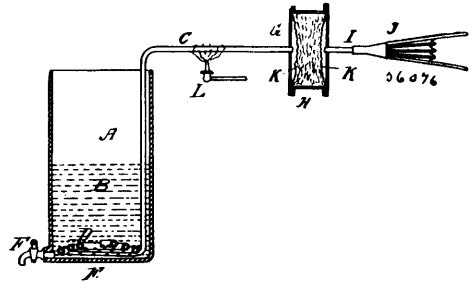

to natural lactic fermentation sufficient to coagulate albuminous sacs of the butter globules, second, suitably heating the material and subjecting it to a non-churning aeration sufficient to produce rapid alcoholic fermentation of the non-fatty solids without breaking the sacs of the butter-globules, and thereby producing a separation of the other elements from the butter globules and facilitating the collection of the globules by specific gravity at the top of the material, substantially as described.

No. 56,077. Jars for Preserving Fruit and Other Substances. (Jarres pour fruits, etc.)

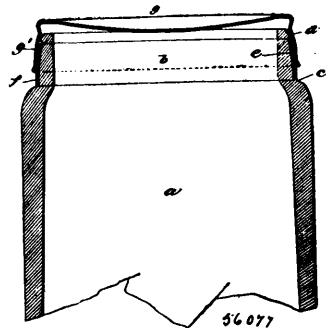

Katherine Ellmaker Gunkle, Frazer, Pennsylvania, U.S.A., 2nd June, 1897; 6 years. (Filed 23rd April, 1897.)

Claim.—As an improved article of manufacture, the herein described jar, having its mouth of essentially the diameter of the body of the jar and with a slightly curved taper externally, and provided with a flat circumferential gasket applied vertically to said tapered portion of the mouth, combined with the metal cover having its skirt or flange essentially cylindrical, whereby said cover is adapted to be applied to the gasket upon the mouth of the jar whether the jar's mouth be of the exact size of the cover or not, substantially as described.

No. 56,078. Lacing. (Lacets.)

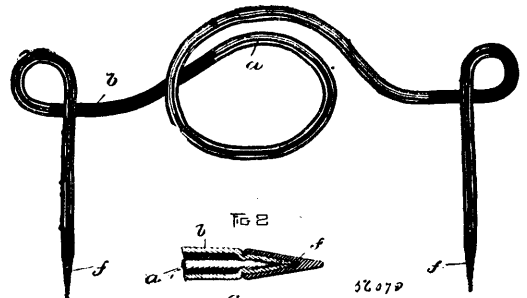

Eleazer Kempshall, Newton, Mass., U.S.A., 2nd June, 1897; 6 years. (Filed 21st April, 1897.)

Claim.—As an article of manufacture, a lacing comprising a tubular woven body or sheath, a non-metallic, flexible core within said sheath and of less diameter than the hole in the sheath, and tips arranged about the ends of the lacing, and anchored to the ends of the core and sheath.

No. 56,079. Fire Escape. (Sauveteur d'incendie.)

Evariste Perreault, Fall River, Massachusetts, U.S.A., 2nd June, 1897; 6 years. (Filed 22nd April, 1897.)

Claim.—1st. A fire escape, having a body portion, a shaft extending through the same, a drum mounted on the shaft, a rope running

forth. 3rd. In hydro-carbon motors, a reservoir c^1 , in combination with the working cylinder a adapted to store air compressed into

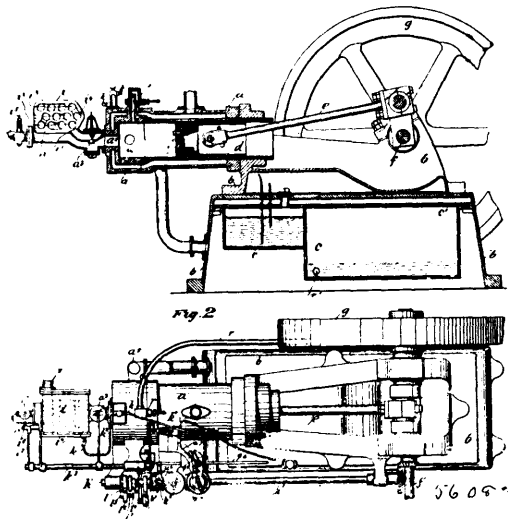

integral upwardly projecting rim-flange, an integral depending flange, and provided with the air and fuel inlets and the smoke-

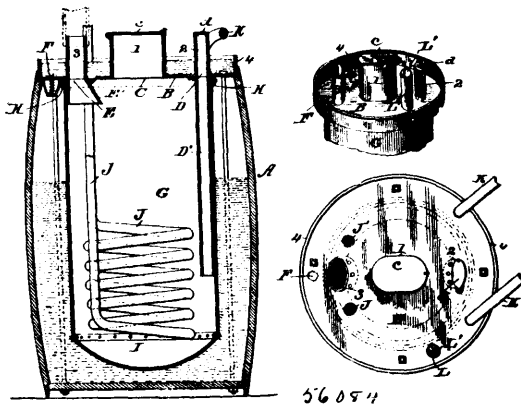

outlet, and with upwardly extending tubes above the fuel-inlet and smoke-outlet and with the funnel leading to the outlet below the cap and the fire-chamber or furnace secured to the depending flange of the cap, all substantially as described and for the purpose set forth.

No. 56,085. Table. (Table.)

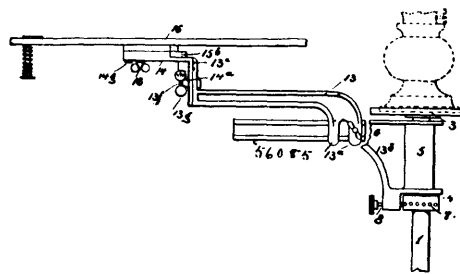

Edward E. Bennett, Lincoln, Nebraska, U.S.A., 2nd June, 1897; 6 years. (Filed 26th April, 1897.)

Claim.—1st. A table-supporting post provided with a bearing at its upper end and a collar at the lower end of said bearing formed with peripheral pin sockets therein, and a table-supporting bracket, having a sleeve and a pin socket formed thereon to fit the journal of the post and hold the pin opposite the sockets of the collar, and a spring-actuated pin having a spur to lock said pin out of engagement with said pin sockets, substantially as described. 2nd. The combination with a table-supporting post, of a bracket arm fitted thereon, an adjustable arm section having a loop or sleeve to slide thereon and adapted to be reversibly connected therewith, a clamping bolt to connect said adjustable arm section and bracket arm, and a table supported upon the arm section, substantially as described. 3rd. The combination with a table-supporting post, a bracket arm, an adjustable arm section having an upturned end plate provided with radial recesses, an angle plate supporting a table having a plate to fit the upturned end plate of the adjustable arm and provided with a rib to fit said radial recesses, and a clamping bolt to secure said angle plate and arm plate together, substantially as described. 4th. combination with a table, of a bracket angle plate having a U-shaped socket upon the horizontal plate thereof, a hub plate secured to the under side of the table to fit into said socket, and a pin fitted upon the said horizontal plate opposite the opening of the socket thereon to hold the hub plate therein, substantially as described. 5th. The combination with a table, of a bracket angle plate having a U-shaped socket, a hub plate secured to the under side of the table to fit into said socket, a pin fitted into the angle plate opposite the opening of the U-shaped socket and a clamping bolt in the angle plate to secure the hub plate and table fixedly thereto, substantially as described.

No. 56,086. Wardrobe. (Garde-robe.)

Bryon R. McIntyre, Flint, Michigan, U.S.A., 2nd June, 1897; 6 years. (Filed 21st April, 1897.)

Claim.—1st. The combination of the grooved heads A and B, with the grooved standards C and C¹, for the engagement of the panels D, substantially as specified. 2nd. The combination of the grooved heads A and B and the grooved standards C and C¹ and the door E formed with the grooved rail e and e¹ engaging the panel f, sub-

the said reservoir c^1 by the action of the piston d by way of valve r and pipe r^1 , (said air being drawn through the main inlet valve a^5), the air so compressed into the reservoir c^1 being afterwards re-admitted into the working cylinder a as required for starting and other purposes connected with hydro-carbon motors, substantially as set forth. 4th. In combination with a hydro-carbon oil motor, a bunsen burner and gas generator combined consisting of two tubular parts m and m^1 , one fitting into the other and formed with a spiral groove m^2 between their faces communicating with a hydro-carbon oil inlet m^3 , and regulating valve m^4 , and hydro-carbon oil-gas outlet and jet-piece in the outer part m^1 , the latter being adapted to receive a burner m^5 , and the inner part m the impact of a bunsenized hydro-carbon oil flame, all substantially as and for the purpose specified. 5th. In combination with a hydro-carbon oil motor, a bunsenized oil gas blow pipe for heating directly or indirectly the extended combustion chamber i^1 , and generator i , consisting of two tubular parts m , m^1 , one fitting into the other and formed with a spiral groove m^2 between their faces communicating with a hydro-carbon oil inlet and regulating valve m^4 , and hydro-carbon oil-gas outlet m^3 , the latter forming the branch piece of a , jet ring n inclosed in a vaporizing dish n^1 , n^2 , below a deflector n^3 , the said vaporizing dish and tubular parts being employed concentrically over a jet pipe n^6 fed with compressed air which comingles with the gas issuing from the jet pipe n , all substantially as set forth. 6th. In hydro-carbon oil motors, the combination of the combustion chamber, the generator i the continuous gas maker, a bunsenized oil-gas blow pipe for the intense preliminary heating of the generator i and the continuous gas maker, and a hydraulic apparatus for the purpose of producing an air pressure to be utilized for intensifying the flame of the said bunsenized oil-gas blow pipe, all substantially as set forth. 7th. In hydro-carbon motors, the employment of a measuring device consisting of a cylinder q and plunger q^1 inside thereof adapted to oscillate on a pivot q^2 formed with oil inlet and outlet q^6 and q^7 , which serve for suction and delivery respectively and communicate alternately with a port q^5 leading to the barrel of the said cylinder, the said inlet and outlet being respectively in communication with a hydro-carbon oil supply tank and a feed regulating tap or valve k^1 , the latter being controlled by the action of the governor and communicating with the vaporizing chamber i^2 of the gas generator i , all substantially as and for the purpose set forth. 8th. In hydro-carbon oil motors, the employment of a hydro-carbon oil supply apparatus immersed in a hydro-carbon oil supply tank and consisting of a disc p formed with concentric chambers p^6 adapted to rotate between a bed plate p^1 and cover plate p^2 , the said bed plate being formed with inlet and outlet p^8 and p^9 respectively, and the said concentric chambers conveying successively the hydro-carbon oil from the inlet p^8 to the outlet p^9 from whence it is drawn into the vaporizing chamber i^2 by the suction of the piston d , all substantially as set forth. 9th. In hydro-carbon oil motors, in combination with the exhaust valve lever h^2 and disc-shaped measuring apparatus, a filling piece or lever u controlled by the action of the governor and adapted to render the exhaust valve lever h^2 inoperative and thus retaining the exhaust valve a^4 off its seat during the waste stroke of the piston for the purpose of governing the speed of the motor, all substantially as set forth.

No. 56,084. Steam Generator and Tank-Heater.

(Générateur à vapeur et chauffeur de réservoirs.)

Thomas Forsythe Butterfield, DeWitt, Iowa, U.S.A., 2nd June, 1897; 6 years. (Filed 23rd April, 1897.)

Claim.—A portable tank-heater, substantially as described, comprising the head-plate or cap forming the tank-top and having an

stantially as set forth. 3rd. The combination of the grooved heads A and B, the grooved standards C and C', and the panels D, the

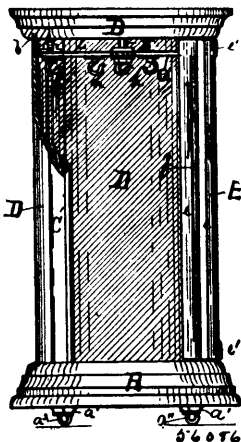

door E, and the rotating arms G, revolving on its axis g and containing the series of hooks h and the rollers L, substantially as specified and set forth.

No. 56,087. Stove. (Poêle.)

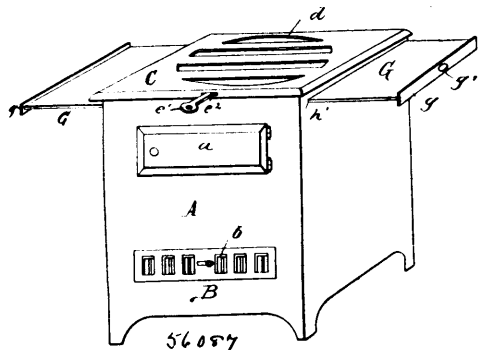

James Rothlisberger, Niagara Falls, and Julius Herman Graichen, Buffalo, both in the State of New York, U.S.A., 2nd June, 1897; 6 years. (Filed 21st April, 1897.)

Claim.—1st. The combination with the stationary top plate of a stove having slots over the fire chamber, of a damper arranged below said top plate and provided with slots adapted to register with the slots of the top plate and having a manipulating device which projects from said damper outwardly below said top plate, whereby said damper can be operated without disturbing the vessel resting on said top plate, substantially as set forth. 2nd. The combination with the stationary top plate of a stove having slots over the fire chamber, of a damper arranged below said top plate and having slots adapted to register with those of the top plate, and an imperforate damper arranged below said slotted damper and adapted to exclude the heat from the same and from the overlying top plate, substantially as set forth. 3rd. The combination with the stationary top plate of a stove having transverse slots over the fire chamber, of a longitudinally movable damper arranged below said slotted top plate and having transverse slots adapted to register with the slots of the top plate and two imperforate dampers arranged below said slotted damper add adapted to be moved transversely in opposite directions for exposing the slotted damper to the heat or excluding the heat therefrom, substantially as set forth.

No. 56,088. Air Hose Coupling. (Joint de boyaux à air.)

James Samuel Arkins, Menomée, Michigan, U.S.A., 2nd June, 1897; 6 years. (Filed 24th April, 1897.)

Claim.—1st. In an air brake hose coupling, the combination with one member of the coupling, of a spring-actuated valve, and means for holding said valve in operative or away from its seat, substantially as described. 2nd. In an air brake hose coupling, the combination with one of the coupling members, of a valve for closing the opening therein, and provision whereby said valve may be held away from its seat for allowing the escape of air, substantially as described. 3rd. In an air brake hose coupling, the combination with one of the coupling members, of a valve normally closing the opening therein and provided with a stem notched as described, and a device for engaging the notch of said stem for hold-

ing the valve away from its seat, substantially as described. 4th. In an air brake hose coupling, the combination with one of the

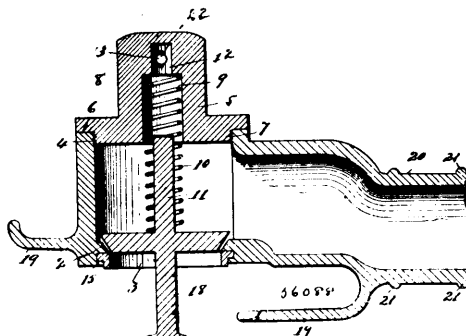

coupling members, of a valve for closing the opening therein, an inwardly projecting stem on said valve provided with a notch as described, a coiled spring surrounding said stem within the body of the coupling member for normally pressing said valve to its seat, and a thumb-screw for engaging the notch in the stem, substantially and for the purpose specified. 5th. In an air brake hose coupling, the combination with one of the coupling members having an opening, of a spring-actuated valve for normally closing said opening, the said valve being provided with an outwardly projecting foot piece adapted to be engaged by the complementary members of the hose coupling for unseating the valve when the two members are joined, substantially as described. 6th. In an air brake hose coupling, the combination with one of the coupling members, of a valve for normally closing the opening of said member, and lateral projections on said valve working in grooves within the coupling member, substantially as described. 7th. In an air brake hose coupling, the combination with one of the coupling members having oppositely arranged grooves as described, of a spring-actuated valve for normally closing the opening in said member, lateral projections on said valve working in said grooves, an inwardly projecting stem on said valve provided with a notch, and a device for engaging said notch and holding the valve away from its seat, substantially as described.

No. 56,089. Car-truck. (Châssis de chars.)

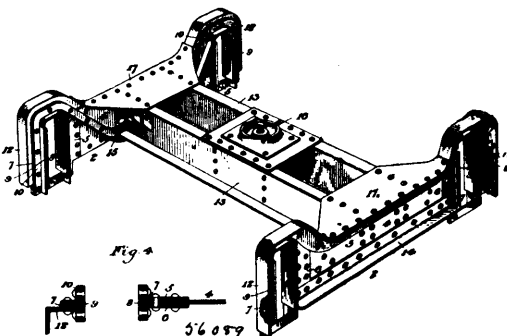

Frederick Henry Kindl, Pittsburg, Pennsylvania, U.S.A., 2nd June, 1897; 6 years. (Filed 20th April, 1897.)

Claim.—1st. A car-truck having a metal frame, said frame having secured to its inner face an angle-iron upon which the transom rests, and having a horizontally-extending strengthening angle-iron secured to its outer face, substantially as described. 2nd. In a car-truck, a side frame having a horizontally-extending angle-iron, the ends of which are bent downwardly and form portions of the pedestal, substantially as described. 3rd. In a car-truck, a slide frame having an upper angle-iron, the ends of which are bent downwardly to form portions of the pedestal, a body-plate secured to the intermediate portion of the angle-iron, and angle-irons of inverted U-shape inclosing the journal-box openings of the pedestals, substantially as described. 4th. In a car-truck, a side frame comprising an upper angle-iron having ends bent downwardly to form portions of the pedestals, a central plate secured to the intermediate portions of said angle-iron, angle-irons of inverted U-shape inclosing the journal-box openings of the pedestals and secured to the end portions of the upper angle-iron, and plates secured to said inverted U-shaped angles and to the central plate, substantially as described. 5th. In a car-truck, a side frame having secured to its inner face an angle-iron, the end portions of which inclose the top and sides of the journal-box opening in the pedestals, while its intermediate portion is bent downwardly to form a rest for the transom, substantially as described. 6th. In a car-truck, a side frame having secured to its inner face an angle-iron, the end portions of which inclose the top and sides of the journal-box opening in this

pedestals, while its intermediate portion is secured to the central plate of the frame, substantially as described. 7th. In a car-truck, a side frame having an upper angle-iron with its end portions bent down to form portions of the pedestal, two angle-irons riveted directly to the downwardly-bent portions, one of said angle-irons being of inverted U-shape, and a flanged plate secured to the inner portion of the pedestal and secured to the inner leg of the inverted U-shape angle, substantially as described. 8th. In a car-track, a side frame having an upper angle-iron with its end portions bent down to form parts of the pedestal, two angle-irons riveted directly to the downwardly-bent portions, one of said angle-irons being of inverted U-shape, the other being a bottom angle-iron, and a flanged plate secured to the inner portion of the pedestal, substantially as described. 9th. In a car-truck, a metal side frame having an upper angle-iron, the ends of which are bent to form parts of the pedestals, and a flat plate having its end portions bent to fit the angle-iron and secured to the angle-iron and to the transom, substantially as described.

No. 56,090. Sewer Trap. (Fermelure d'égout.)

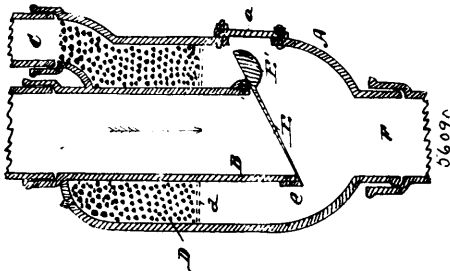

Ezra Henry Rogers, Detroit, Michigan, U.S.A., 2nd June, 1897; 6 years. (Filed 20th April, 1897.)

Claim.—1st. In a sewer trap, the combination of the outer shell, a soil or waste pipe, and an inclined weighted valve pivoted thereto, substantially as described. 2nd. In a sewer trap, the combination of the outer shell, a soil or waste pipe, a ring encircling said soil or waste pipe, and an inclined weighted valve pivoted to said ring, substantially as described. 3rd. In a sewer trap, the combination of the outer shell, a soil or waste pipe located within said shell, a disinfected chamber, perforations in said soil or waste pipe affording communication with the disinfected chamber, a cover provided with an opening leading into the soil or waste pipe, suitable openings in said cover leading into the disinfected chamber and provided with means for closing the same, and an inclined weighted valve pivoted to said soil or waste pipe, substantially as described. 4th. In a sewer trap, the combination of the outer shell, a soil or waste pipe, and an inclined weighted valve pivoted thereto, said valve formed with a cup-shaped portion filled with lead or other suitable material, substantially as described.

No. 56,091. Pipe Coupling. (Joint de tuyaux.)

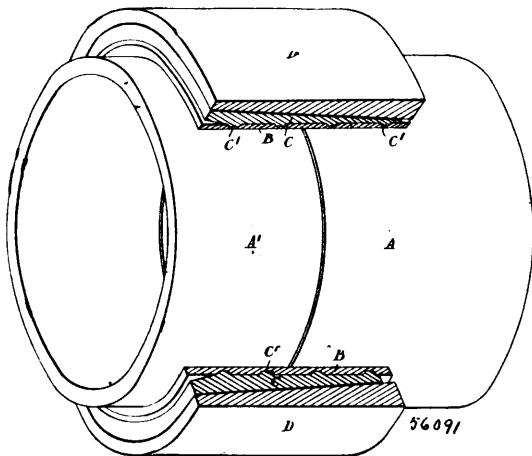

David John Russell Duncan, Westminster, England, 2nd June, 1897; 6 years. (Filed 21st April, 1897.)

Claim.—1st. Making a pipe joint by forcing an internally tapered sleeve or compression ring such as D onto a compressible wedge such as C, both D and C forming parts of the permanent joint, substantially as and for the purpose described. 2nd. In a pipe joint, the employment of an external compression ring, forming part of the permanent joint, substantially as described. 3rd. In a pipe

joint, the employment of a compressible wedge such as C, forming part of the permanent joint, substantially as described. 4th. In a pipe joint, a circumferentially tapered wedge, which is also the packing, substantially as described. 5th. In a pipe joint, the combination of a sleeve or compression ring, a circumferentially tapered wedge and a packing strip all forming parts of the permanent joint, substantially as described. 6th. In a pipe joint, the combination of a sleeve or compression ring and a circumferentially tapered wedge having a packing strip attached to it, and all forming parts of the permanent joint, substantially as described.

No. 56,092. Deep Boring Apparatus. (Appareil à percer.)

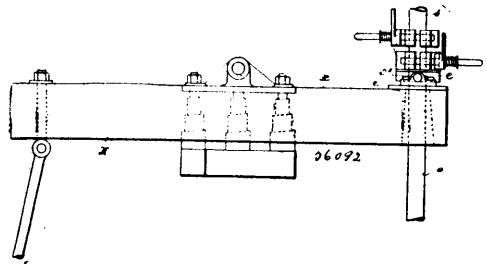

Anton Raky, Rupprechtsan, Alsace, Germany, 2nd June, 1897; 6 years. (Filed 24th April, 1897.)

Claim.—1st. In a boring apparatus for deep borings, having the rods held by a lowering device consisting of two clamps arranged one over the other upon one of the boring rods, and being adapted to be fixed to, loosened from, and displaced along the same, the combination with said clamps, of means for limiting the way of upward displacement of the upper clamp, substantially as and for the purpose hereinbefore set forth. 2nd. In a boring apparatus for deep borings, having the rods held by a lowering device consisting of two clamps arranged one over the other upon one of the boring rods, and being adapted to be fixed to, loosened from, and displaced along the same, the combination with said clamps, of means for mechanically raising the upper clamp off the lower one up to a predetermined height, substantially as and for the purpose hereinbefore set forth. 3rd. In a boring apparatus for deep borings, having the rods held by a lowering device consisting of two clamps arranged one over the other upon one of the boring rods, and being adapted to be fixed to, loosened from, and displaced along the same, the combination with said clamps, of pins held by the upper clamp and resting upon the lower one, springs arranged upon said pins, traverses guided by the latter and supported by said springs, and bolts secured at one end to said traverses and at the other end to the upper clamp, substantially as and for the purpose hereinbefore set forth.

No. 56,093. Boring Apparatus for Deep Borings. (Appareil à percer.)

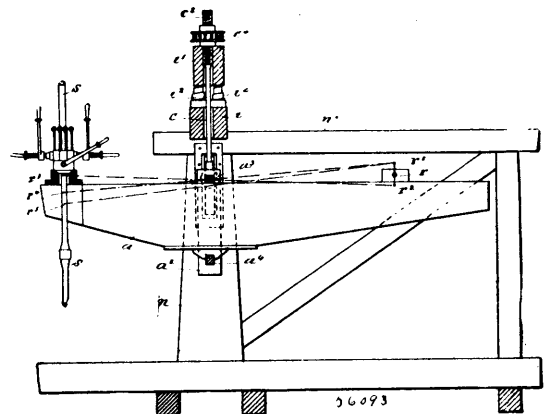

Anton Raky, Rupprechtsan, Alsace, Germany, 2nd June, 1897; 6 years. (Filed 24th April, 1897.)

Claim.—1st. In a boring apparatus for deep borings, having an oscillating beam, the combination with the latter and its axle, of means for raising or lowering this axle, substantially as and for the purpose hereinbefore set forth. 2nd. In a boring apparatus for deep borings, having an oscillating beam, the combination with the latter, its axle, and the bearings or supports of this axle, of means for raising or lowering said bearings or supports, substantially as and for the purpose hereinbefore set forth. 3rd. In a boring apparatus for deep borings, having an oscillating beam, the combination with the latter and its axle, of rods holding the latter or its bearings or supports, and means for moving said rods so as thereby to raise or lower

the said axle, substantially as and for the purpose hereinbefore set forth. 4th. In a boring apparatus for deep borings, having an oscillating beam, the combination with the latter and its axle, of vertical rods holding the latter or its bearings or supports, and means for moving said rods in their longitudinal direction, substantially as and for the purpose hereinbefore set forth. 5th. In a boring apparatus for deep borings, having an oscillating beam, the combination with the latter and its axle, of vertical rods holding the latter or its bearings or supports, and means for moving said rods in their longitudinal direction, the other ends of said rods being screw-threaded and having worm-wheels upon these ends, and being combined with a worm for rotating said wheels, substantially as and for the purpose hereinbefore set forth. 6th. In a boring apparatus for deep borings, having an oscillating beam, and an elastic support for said beam, the combination with the latter, and its axle, of means for raising or lowering this axle independent of the tension or strength of the elastic means of said support, substantially as and for the purpose hereinbefore set forth. 7th. In a boring apparatus for deep borings, having an oscillating beam and an elastic support for said beam, the combination with the latter and its support, or means for increasing the tension or strength of the elastic means of said support according to the increase in weight of the rods on the latter being elongated to the increase in depth of the bore-hole, substantially as and for the purpose hereinbefore set forth. 8th. A boring apparatus for deep borings, having an oscillating beam supported by a number of loose springs adapted to be put between, or removed from, the two frame-beams holding, and being held by, said springs, the tension or strength of the combined springs being regulable according to the weight of the rods by correspondingly determining the number of the said springs, substantially as and for the purpose hereinbefore set forth.

No. 56,094. Machine for Forming Seamless Shoes.

(Machine pour la fabrication de chaussures sans coutures.)

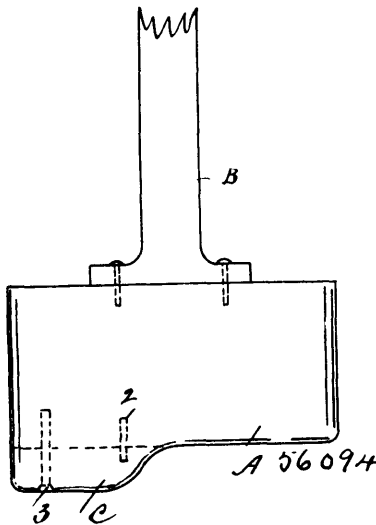

Thomas Timoch Marshall, Hamilton, Ontario, Canada, 3rd June, 1897; 6 years. (Filed 24th April, 1897.)

Claim.—1st. A device of the character described, consisting of a former or die of suitable design and construction having a lower in-step formation for shoes, said die to receive a single piece of leather of suitable design, a divided dieplate in frame to conform to said die or former, in combination with power connected to upper slide bar of former or die, substantially as described. 2nd. In a device of the character described, a former or die of suitable design and construction provided with a lower shoe in-step former secured thereto, a piece of leather, applied to the lower part thereof, a suitable parted dieplate to conform to and to receive said die, a slide bar on the upper part of the die for connection with means for operating the same, substantially as described and set forth. 3rd. A device of the character described, consisting of a former or die of suitable design and construction a single piece of leather applied to the lower part thereof to form moccasins a suitable dieplate in halves to conform to said die with leather a slide bar on the upper part of the die for connection with means for operating the same, substantially as described. 4th. In a device of the character described, a former or die of suitable design or construction provided with a lower detachable bicycle shoe in-step former having pin 2, and flush headed screw 3, a single piece of leather applied to the lower part of said die, a suitably parted dieplate to conform to said die with leather a slide bar secured to and vertical with the upper part of the die and power applied to said slide, substantially as described.

No. 56,095. Brake Shoe. (Sabot de frein.)

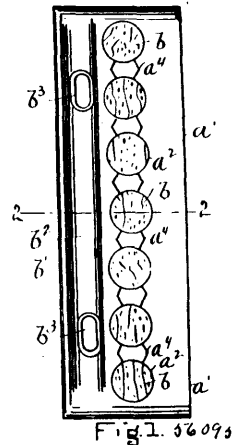

William Wirt Whitcomb, Brooklyn, and Frank Fiske Coggin, Wakefield, both in Mass., U.S.A., 3rd June, 1897; 6 years. (Filed 23rd April, 1897.)

Claim.—1st. As an improved article of manufacture, a composite brake-shoe consisting of a metal body portion provided with one or more sockets or openings, and a cork block or section fitted into said opening and retained therein by the expansion of the cork in its socket, substantially as and for the purpose specified. 2nd. As an improved article of manufacture, a brake-shoe provided with a plurality of sockets a^2 and connecting intervening openings a^1 formed in that part of the body portion in line with the portion of the tread of the wheel worn by the rail, and cork sections or blocks inserted into the sockets a^2 in a compressed state, substantially as and for the purpose specified. 3rd. As an improved article of manufacture, a composite brake-shoe consisting of a body portion provided with a plurality of sockets or openings, and a plurality of compressed cork sections inserted into said sockets or openings and retained therein solely by the expansion of the cork, substantially as described.

No. 56,096. Lumberman's Boot. (Chaussure.)

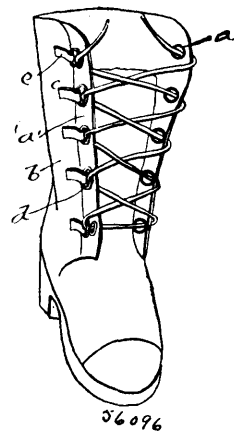

James Whitham, Montreal, Quebec, Canada, 3rd June, 1897; 6 years. (Filed 20th April, 1897.)

Claim.—A lumberman's boot having eyelets a in the front edges of the quarters thereof and auxiliary holdfast rings d located concentrically of the eyelets and secured to the quarters by attachment strips c , substantially as and for the purpose set forth.

No. 56,097. Raisin Seeding Machine. (Vide raisin)

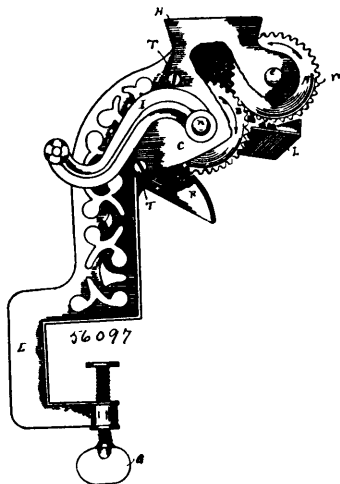

Charles L. Spencer, Providence, Rhode Island, U.S.A., 3rd June, 1897; 6 years. (Filed 26th April, 1897.)

Claim.—1st. In a raisin seeder, the combination of a frame, the upper end of which is provided with a perforated web or flange, of plates secured to said perforated portion, said plates being provided with flanges, which abut each other and form a hopper, each of said plates being provided with perforations forming bearings, an elastic roller journaled in two of said bearings, the periphery of which is provided with longitudinal corrugations, a crank-shaft in the other bearings, gear-wheels and washers alternately secured on said shaft, a clearer, and a shedder, substantially as set forth. 2nd. In a raisin seeder, the combination with a frame, of plates secured to the upper end thereof, said plates being provided with a hopper, an elastic roller and a series of geared wheels journaled between said plates, a clearer provided with wings secured to the plates below the elastic roller, the portion of the clearer between the wings being cut away on a curve to correspond with the curvature of the wheels, and secured adjacent thereto, and a shedder, substantially as set forth. 3rd. In a raisin seeder, the combination with a frame, of plates secured to the upper end thereof, an elastic roller and a series of geared wheels journaled between the plates, a series of washers alternately between the wheels, a clearer below the elastic roller, and a shedder secured between the lower portion of the plates between the wheels, and the lower portion being provided with a spout, substantially as set forth.

No. 56,098. Car-brake. (Frein de chars.)

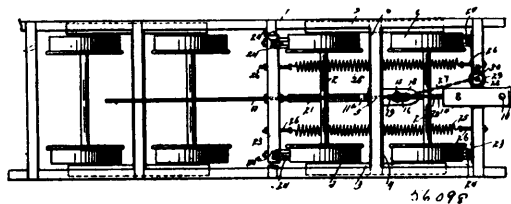

Benjamin F. Jackson, Sutton, West Virginia, U.S.A., 3rd June, 1897; 6 years. (Filed 26th April, 1897.)

Claim.—1st. In a car-brake, the combination of wheels, brake-beams having shoes engaging the wheel-treads, springs connecting the brake-beams and arranged to hold the same with their shoes normally engaging the car-wheels, rods having their inner ends adjacent and having their outer ends connected to the brake-beams, a draw-head, and a lever connected to and arranged to be moved by said draw-head, said lever having engagement with the inner ends of the brake-bars, and being adapted when moved to actuate said brake-rods to move the brake-beams, substantially as set forth. 2nd. In a car-brake, the combination of wheels, brake-beams having shoes engaging the wheels, a truck-frame whereon the wheels are mounted, a car-body supported on the truck-frame, means for supporting the brake-beams from the car-body, a box carried on the truck-frame and having a passage extending through it, springs connecting the brake-beams and arranged to hold the same with their shoes normally engaging the wheels, brake-rods connected at their outer ends to the brake-beams and having their inner ends arranged to slide in the passage in said box, a pivoted brake-lever having one end engaging the brake-rods and adapted to move the same in opposite directions, a draw-head, and a connection between the draw-head and the lever, arranged when the draw-head is moved to actuate said lever to disengage the brake-lever from the wheels, substantially as set forth.

3rd. In a car-brake, the combination of wheels, brake-beams having shoes engaging the wheels, a truck-frame whereon the wheels are mounted, a car-body supported on the truck-frame, means for supporting the brake-beams from the car-body, a box carried on the truck-frame and having a passage extending through it, springs connecting the brake-beams and arranged to hold the same with their shoes normally engaging the wheels, brake-rods connected at their outer ends to the brake-beams and having their inner ends arranged to slide in the passage in said box, a pivoted brake-lever having one end engaging the brake-rods and adapted to move the same in opposite directions, a draw-head, a connection between the draw-head and the lever, arranged when the draw-head is moved to actuate said lever to disengage the brake-lever from the wheels, a brake-staff having a pawl-and-ratchet device, and a chain connected to the lever and arranged to be wound on the brake-staff, substantially as set forth.

No. 56,099. Envelope. (Enveloppe.)

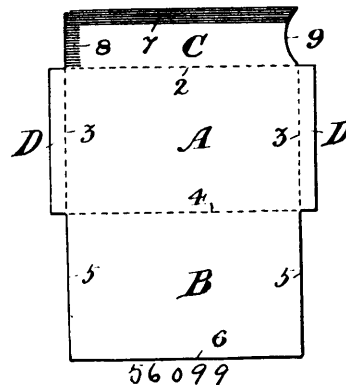

David A. Ross, Quebec, Quebec, Canada, 3rd June, 1897; 6 years. (Filed 14th April, 1897.)

Claim.—1st. In an envelope, the combination with the body of the envelope, of a closing flap of a substantially rectangular shape, having its upper edge and one side gummed and the other side scalloped out, so that the envelope may be quickly opened with the finger, as described as set forth. 2nd. In an envelope, the combination with the body of the envelope, of a closing flap, the said flap having its free edge parallel to the upper edge of the envelope and reaching entirely across, a gummed margin on the said flap, and having its edge or edges scalloped out, substantially as set forth. 3rd. In an envelope, the combination with the body of the envelope, of the flap C, having gummed margins 7 and 8, and one of its edge scalloped out or hollowed out, as at 9, substantially as set forth.

No. 56,100. Smoke Consumer. (Appareil fumivore.)

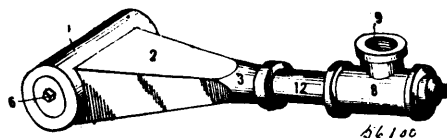

Reuben R. Bryant and Horace R. Wheeler, both of Detroit, Michigan, U.S.A., 3rd June, 1897; 6 years. (Filed 29th April, 1897.)

Claim.—1st. As a new article of manufacture, a device for the purpose set forth, consisting of a chamber having a curved front wall, said wall having apertures therein, a movable body in said chamber, and said chamber having communication with a suitable steam source, substantially as described. 2nd. A device for the purpose set forth, consisting of a cylindrical chamber closed at its ends and having a series of perforations in its front wall, a steam connection at its rear side, and balls or slugs adapted to operate within said chamber, substantially as described. 3rd. A boiler provided with a chamber suitably connected thereto, said chamber having apertures adapted to be alternately opened and closed by means of movable bodies located therein. 4th. A boiler provided with a cylindrical chamber located within the fire-box thereof, and connected thereto, said chamber having at its inner face, apertures adapted to be alternately opened and closed by means of movable bodies located therein. 5th. A smoke consuming device comprising a cylindrical chamber, located within the fire-box of a boiler, and provided at its inner face with apertures adapted to be alternately opened and closed by means of movable balls, said chamber having internally formed on its rear portion, a super-heating chamber, terminating in a sleeve adapted to form a pipe connection. 6th. A smoke consumer comprising a cylindrical chamber provided with apertures on its inner portion, independently moving bodies within said chamber, adapted to alternately open and close said apertures, a super-heating chamber formed integral with said cylindrical cham-

ber, and provided with partitions, said super-heating chamber terminating in a flanged sleeve adapted to form a pipe connection whereby the cylindrical chamber is connected with the steam dome of the boiler. 7th. A device for the purpose set forth, consisting of a cylindrical chamber closed at its ends and having a series of diverging apertures through its front wall, a plurality of movable bodies adapted to operate against the curved wall of said chamber, and said chamber having a super-heating box formed integral therewith and extending therefrom, and means on said box for connection with a steam source, substantially as described. 8th. A device for the purpose set forth, consisting of a cylindrical chamber 1, closed at its ends by means of screw-plugs, said chamber having a series of diverging apertures arranged in alignment with each other in the front wall of said chamber, a plurality of movable bodies located within said chamber and adapted to operate against the front curved wall thereof, a super-heating chamber formed integral with said chamber 1, and extending therefrom, said super-heating chamber having a steam partition therein, and means for a steam connection therewith, substantially as shown and described. 9th. A system, for the purpose set forth, consisting of a cylindrical chamber 1 having balls therein and a series of apertures 5 through its curved front wall, said chamber being closed at its ends and having a super-heating chamber or box 2 formed integral therewith and extending therefrom, a plurality of diverging steam partitions in said box, all of which parts are adapted to be extended into a fire-box in about the position shown and described, a pipe forming a steam connection between said super-heating box and a T connection outside of the front wall, a pipe forming a steam communication between the interior of a boiler and said T, and means for regulating the flow of steam, substantially as described.

No. 56,101. Hat Case. (Boîte à chapeau.)

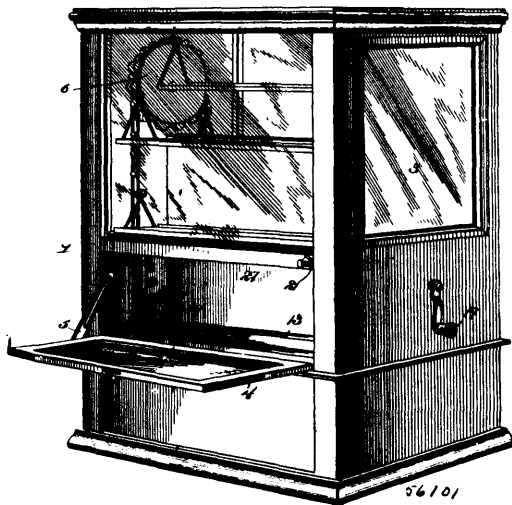

Robert Szczyz, John J. Sprafka and Henry O'Keefe, all of Minto, North Dakota, U.S.A.. 3rd June, 1897; 6 years. (Filed 29th April, 1897.)

Claim.—1st. In a display-rack, the combination of a case or cabinet, upper and lower sprocket wheels arranged therein and disposed at opposite sides thereof, endless sprocket chains, to permit the shelves to move freely, arranged on the sprocket wheels, a series of shelves pivotally connected with and carried by the endless chains, and a spring-actuated bolt arranged to engage the links of one of the sprocket chains, extending through a slot of the case and provided at its outer end with a lug, adapted, when the plate is withdrawn, to be turned transversely of the slot, whereby the bolt is held out of engagement with the sprocket chain, substantially as described. 2nd. In a display-rack, the combination of a case or cabinet, upper and lower sprocket wheels, sprocket chains arranged thereon, a series of shelves pivotally connected to and carried by the endless chains, a housing located opposite one of the sprocket chains and provided, at its inner end, with upwardly and downwardly extending arms, a plate arranged adjacent to the housing, disposed at the opposite side of the adjacent portion of the sprocket chains and provided with an opening, the terminals of the bolts and arms being diverged, and a spring-actuated belt mounted in the housing and adapted to extend through a link of the sprocket chains and the opening of the plate, said belt being arranged in the slot of the case and provided with a lug adapted, when the bolt is withdrawn, to be disposed transversely of the slot, whereby the bolt is held out of engagement with the sprocket chain, substantially as described. 3rd. In a display-rack, the combination of a case or

cabinet, upper and lower sprocket wheels, sprocket chains arranged on the wheels, a series of shelves pivotally connected to and carried by the endless chains, a housing located opposite one of the sprocket chains and provided at its inner end with upwardly and downwardly extending arms and located at the outer side of the adjacent sprocket chain, a plate located on the inner side of the latter, located adjacent to the housing and provided with an opening, and a bolt mounted in the housing and adapted to extend through a link of the adjacent sprocket chain and through the opening of said plate, substantially as described.

No. 56,102. Carpet Sweeper. (Balayuse de tapis.)

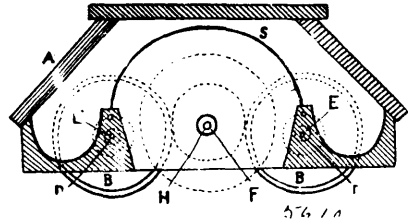

Bissell Carpet Sweeper Co, assignee of Walter J. Drew, both of Grand Rapids, Michigan, U.S.A., 3rd June, 1897; 6 years. (Filed 30th April, 1897.)

Claim.—1st. In a carpet sweeper, the combination of the drive-wheels, a journal extending through the end wall of the case, openings through the end wall of the case for the reception of said journal, a dust-pan into which said journal or pivot is driven, and a spring adapted to close the said dust-pans, substantially as described. 2nd. The combination of a sweeper case, the drive-wheels placed on the outside of said case, a pivot or journal passing through enlarged openings in said case and supporting the wheels placed on the outside and entering into the dust-pan and rigidly connected therewith, a brush-roller, a pair of dust-pans, each dust-pan turning upon the same pivot as its corresponding drive-wheel, a spring attached to each dust-pan at a point eccentric the turning point of said dust-pan, said spring adapted to retain the dust-pans closed and also to produce frictional contact between the drive-wheels and the brush-roller, substantially as described. 3rd. The combination of a sweeper case, the drive-wheels placed on the outside of said case, a pivot or journal for the brush-roller passing through enlarged openings in the ends of the case and supporting the wheels on the outside and entering into the dust-pan and rigidly connected therewith, a brush-roller, a pair of dust-pans, each dust-pan turning upon the same pivot at its corresponding drive-wheel, a spring attached to each dust-pan at a point adapted to retain the dust-pans closed, and also to produce frictional contact between the drive-wheels and the brush-roller, substantially as described. 4th. The combination in a carpet sweeper, of a case, a pivot extending through an enlarged opening in the case, a drive-wheel mounted on the outer end of said pivot and adapted to revolve thereon, a dust-pan within the case rigidly attached to the said pivot and turning with the same when the dust-pan is tilted, substantially as described. 5th. In a carpet sweeper, and in combination with the case thereof, of a dust-pan composed of a single piece of wood, open at both ends, secured within the case by means of a pivot passing through the end of the case, substantially as described.

No. 56,103. Wagon Body, for Carrying Grain, etc., in Bulk. (Boîte à grain pour wagons.)

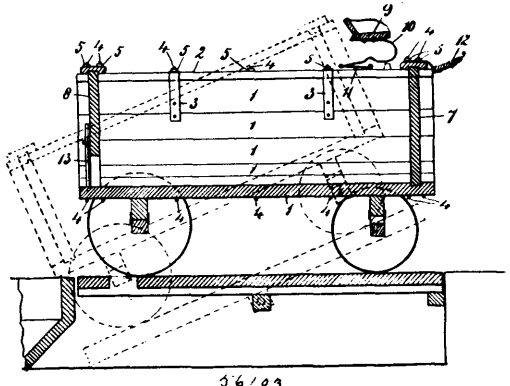

William J. W. Kennedy and John Ketter, both of Newota, Manitoba, Canada, 3rd June, 1897; 6 years. (Filed 30th April, 1897.)

Claim.—1st. A wagon body or grain tank, having a semi-circular bottom and built of straight staves 1, the ends closed by fixed heads 7, 8, and having a coping 2, at the sides and ends, internal clamps

3, and outside bands 4, having the ends screw-threaded and passing through the coping, and provided with nuts 5, to tighten the staves together, as set forth. 2nd. The seat springs 10, having a folding flap-section 11 hinged thereto and to the coping, for adjustment of the seat, as set forth.

No. 56,104. Book Supporter. (*Support pour livres.*)

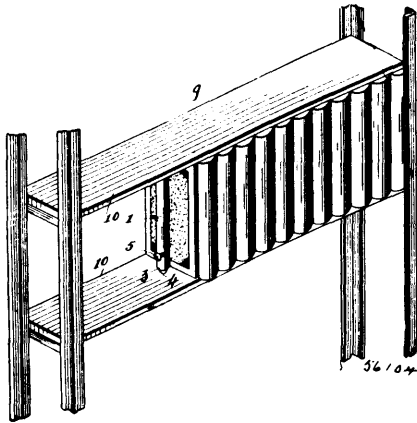

George W. Ladd, East Freetown, Mass., U.S.A., 3rd June, 1897; 6 years. (Filed 26th April, 1897.)

Claim.—1st. A book supporter having a prong at the lower end thereof adapted to engage the upper surface of a book shelf, and a spring-pressed prong in the upper end thereof adapted to engage the lower surface of the next higher book shelf. 2nd. A book supporter having a prong at the lower end thereof adapted to engage the upper surface of a book shelf, a spring-pressed prong in the upper end thereof adapted to engage the lower surface of the next higher book shelf, and means for changing the length of said supporter, substantially as and for the purpose described. 3rd. A book supporter made up of a tubular member having a prong at one end and a partition on the inside thereof, a spindle slidingly mounted in said tubular member provided with a prong upon its outer end and located at a point opposite the prong on said tubular member, and a spring for normally urging said spindle outwardly engaging the upper surface of said partition, substantially as and for the purpose described. 4th. In a book supporter, the combination with a tube, of a rod or bar adjustably mounted in the lower end of said tube having a tooth or projection upon its lower end, and an outwardly spring-pressed spindle in the opposite end of said tube provided with a prong or projection upon its upper end, substantially as and for the purpose described. 5th. In a book supporter, the combination with a tube, of a slidingly mounted rod or bar fitting within the lower end thereof provided with a pointed prong or projection upon its lower end, a thumb screw extending through said tube engaging the outer surface of said rod or bar for adjusting the relative positions of said tube and bar, and an outwardly spring-pressed spindle in the opposite end of said tube having a pointed prong or projection on its outer end, substantially as and for the purpose described. 6th. In a book supporter, the combination with a tube having a partition on the inside thereof, of a slidingly mounted rod or bar in the lower end of said tube having a pointed prong or projection upon it, a thumb screw for adjusting the relative positions of said tube having a pointed prong or projection upon its outer end, and a spring engaging the under side of said spindle and the upper surface of said partition, substantially as and for the purpose described.

No. 56,105. Furnace. (*Fournaise.*)

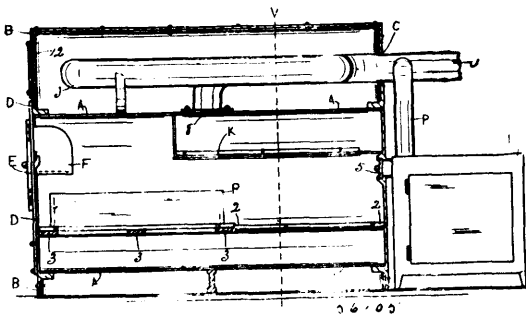

Thomas Heddon, Hamilton, Ontario, Canada, 3rd June, 1897; 6 years. (Filed 27th April, 1897.)

Claim.—1st. A furnace of the character described, consisting of a longitudinal steel plate furnace forming an elliptical tube, and riveted

and provided with front and rear vertical plates secured thereto, a suitable fire grate supported on transverse bars on longitudinal ledges, in combination with a cook-stove capable of receiving hot air from the furnace through an opening in rear projection of said rear plate, the hot air radiating around the oven in the stove and passing into a coiled smoke pipe by means of vertical pipe connections, substantially as described. 2nd. A furnace of the character described, having upper and lower semi-circular form and riveted and provided with front and rear vertical plates, secured thereto, said front plate having outer attached plate with opening and door and an inner detachable shute, a coiled smoke pipe resting on the furnace, in combination with a stove capable of receiving hot air through opening in rear plate of furnace, connecting pipes from the stove to the said smoke pipe, and means for regulating the hot air admitted into the stove, substantially as described. 3rd. A furnace of the character described, having upper and lower semi-circular form and riveted and provided with front and rear vertical plates, secured thereto, said front plate having outer attached plate with opening and door and an inner detachable shute, a fire-box and grate for coal, a diaphragm K, terminating in front of the smoke outlet into a coal smoke pipe resting on the furnace, in combination with a stove capable of receiving hot air through opening in rear plate of furnace, connecting pipes from stove to the said smoke pipe, and means for regulating the hot air admitted into the stove, substantially as described. 4th. A furnace of the character described, in combination with a cook stove connected to the rear end thereof by means of the hot air passages having regulating slides and formed on rear vertical plates of the furnace and entering the upper part of the connected end of the stove, a hot air passage around the central oven of the stove and upwards through the vertical pipes which connect said passage to the furnace smoke pipe coiled on the top of the furnace, and an opening 12, with cover in front plate of furnace, said plate provided with attached outer plate with inner coal shute, substantially as described. 5th. A furnace of the character described, consisting of one or more steel plates riveted together forming an elliptical tube with a removable diaphragm terminating in front of the smoke outlet and a removable fire-pot capable of resting on the furnace grate in combination with a cook stove having a hot air channel around the oven and pipes attached to stove, connected to furnace smoke pipe, and a damper for admitting and cutting off hot air from the furnace, substantially as described. 6th. A furnace of the character described, in combination with a cook stove hot air from the furnace circulating through a channel around the oven of the stove and up through pipes connected to the furnace smoke pipe, and a damper in said smoke pipe manipulated by rod O, substantially as described.

No. 56,106. Stopper for Bottles.

(*Bouchon pour bouteilles.*)

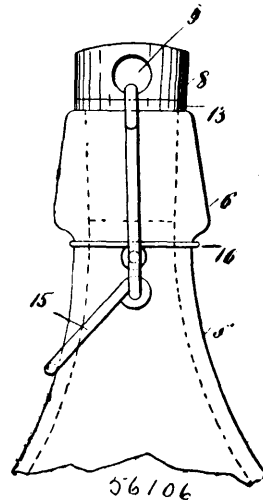

Ferdinand August Keiner, Brooklyn, New York, U.S.A., 3rd June, 1897; 6 years. (Filed 28th April, 1897.)

Claim.—1st. A stopper for bottles or similar vessels, comprising a cylindrical portion on which is formed an annular head, and a tubular casing mounted on said cylindrical portion, said cylindrical portion being provided at its lower end with a screw-thread, substantially as shown and described. 2nd. A stopper for bottles or similar vessels, comprising a cylindrical portion on which is formed an annular head and a tubular casing mounted on said cylindrical portion, said cylindrical portion being provided at its lower end with a screw-thread, and said casing being provided at its upper end with an annular flange or rim, substantially as shown and described. 3rd. A stopper for bottles or similar vessels, comprising a cylindrical portion on which is formed an annular head, and a tubular casing mounted on said cylindrical portion, said cylindrical portion

being provided at its lower end with a screw-thread, and said casing being provided at its upper end with an annular flange or rim, and the head of the cylindrical portion of the stopper being provided with a transverse opening, substantially as shown and described.

No. 56,107. Collapsible Box. (Boîte pliante.)

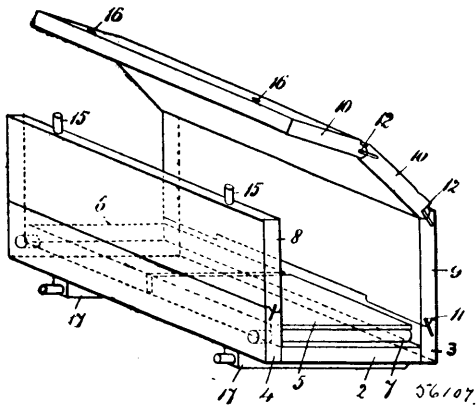

Thomas S. Usher, Brantford, Ontario, Canada, 3rd June, 1897; 6 years. (Filed 28th April, 1897.)

Claim.—1st. A collapsible wooden box, comprising a bottom 2, back and front strips 3 and 4 nailed thereto, ends 5 and 6 folding inwardly flat against said bottom, a front 8 hinged to strip 4, and folding upon said ends, and a back 9 and top 10 in sections hinged together and to strip 3, and folding upon the front, as set forth. 2nd. A collapsible wooden box composed of an integral bottom and side strips and section, forming the front, back and top, connected thereto, and to one another by a hollow and round hinge-joint and a pintle passing therethrough, and ends folding inwardly, the front folding upon the ends and the back upon the front, and the top sections against the front and strip 4, as set forth.

No. 56,108. Pulley. (Poulie.)

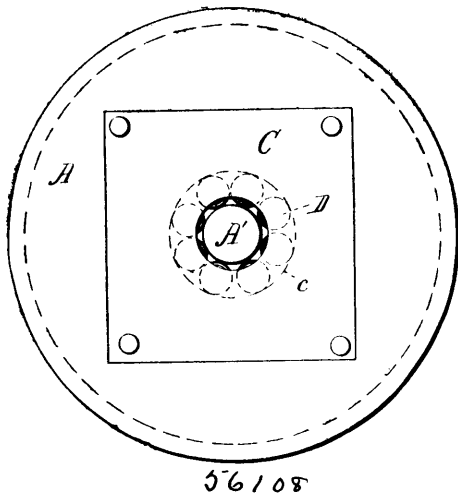

William Symphorien Melanson, Church Point, Nova Scotia, 3rd June, 1897; 6 years. (Filed 28th April, 1897.)

Claim.—The combination, with a wheel or pulley, of a central plate let into it and provided with a ball race on each side, two similar plates arranged adjacent to the aforesaid plate, and each provided with a ball race, and balls running in the said ball races, substantially as set forth.

No. 56,109. Whiffletree Attachment.

(*Attelage de palonniers.*)

William D. Hopkins, Goffstown, New Hampshire, U.S.A., 3rd June, 1897; 6 years. (Filed 27th April, 1897.)

Claim.—As a new article of manufacture, a whiffletree attachment consisting of a pair of wires twisted together at their central portions

and having their extremities bent outwardly and then downwardly

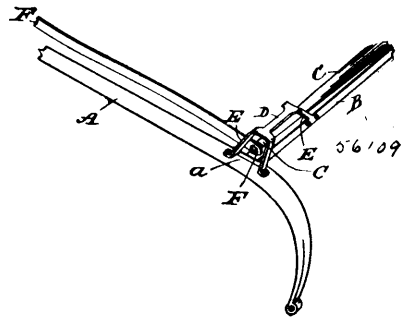

to form yokes, an attaching plate secured to the extremities of one yoke and an attaching plate secured to each end of the second yoke.

No. 56,110. Barrel-Forming Machine.

(*Machine pour la fabrication des barils.*)

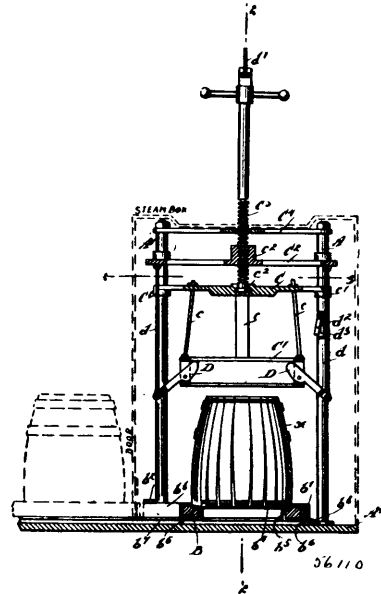

John Hauenstein, Brewer, New Uhn, Minnesota, U.S.A., 3rd June, 1897; 6 years. (Filed 26th April, 1897.)

Claim.—1st. A barrel-forming machine, comprising a carriage adapted to support a barrel and receive a hoop, a vertically-movable, contractible ring, means for raising and lowering the said ring to engage the barrel-staves near the ends resting on the carriage, and mechanism for operating the contractible ring to bend the ends of the staves inward, the end of the barrel when the staves are bent inward being adapted to be forced into the hoop held in the carriage, substantially as specified. 2nd. A barrel-forming machine, comprising a carriage adapted to receive a hoop and support a barrel, a cam-ring, a series of levers pivoted thereto and having cam-shaped inner ends, mechanism for simultaneously operating the cams to bend the ends of the barrel-staves inward, and means for forcing the end of the barrel within the hoop held in the carriage, substantially as specified. 3rd. A barrel-forming machine, comprising a platform, standards extended therefrom, a sectional carriage adapted to receive a hoop and to support a barrel, movable on the platform, a presser-plate movable vertically on the standards, a screw-plate movable vertically on the standards, a screw engaging both of said plates, a cam-ring supported by the presser-plate, cam-levers pivoted in the cam-ring, and connections between the cam-levers and screw-plate, substantially as specified. 4th. In a barrel-forming machine, the combination with a ring-shaped carriage adapted to support a barrel and comprising hinged sections adapted to receive a hoop, and locking means for said sections, of cams adapted to engage the barrel-staves to bend the ends of the staves inward, and means for forcing, the barrel downward, whereby its end is carried within the hoop, substantially as specified. 5th. In a barrel-forming machine, the combination with standards, of a screw-plate movable vertically thereon, a presser-plate also movable vertically thereon, cams supported by the presser-plate and having connection with the screw-plate, an operating-screw engaging the screw-plate and presser-plate, and the yielding stops, substantially as specified. 6th. A barrel-forming machine,

comprising a contractible ring, consisting of a ring and a series of levers pivoted to said ring, and having cam-shaped inner ends, a vertically-movable plate supporting said ring, a vertically-movable screw-plate connected with the said cam-levers, and an operating-screw engaging the supporting-plate and screw-plate, substantially as specified.

No. 56,111. Vehicle Brake. (Frein de voitures.)

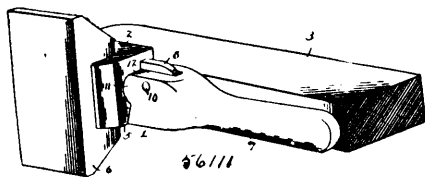

Isaac Newton Keeling, Tomahawk, Arkansas, U.S.A., 3rd June, 1897; 6 years. (Filed 26th April, 1897.)

Claim.—The combination with a brake-shoe of a clamping device comprising a back provided at its inner end with a vertical flange or tongue, a stationary jaw located at the outer side of the back and rigid therewith, and engaging the brake-shoe, a movable jaw engaging the inner side of the brake-shoe, and provided with an opening receiving the said flange or tongue, and a locking lever fulcrumed on the flange or tongue above its centre, and provided adjacent to its upper edge with a cam 11, and having a shoulder below the latter, said shoulder forming a stop adapted to engage the movable jaw, and maintaining the lever in substantially a horizontal position when the parts are locked, substantially as described.

No. 56,112. Clamp for Wire Fences. (Crampon pour clôtures en fil de fil.)

(Crampon pour clôtures en fil de fil.)

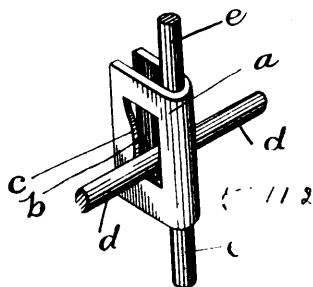

Harry Louis Frost, Columbus, Ohio, U.S.A., 3rd June, 1897; 6 years. (Filed 26th April, 1897.)

Claim.—In a clamp for wire fences, a metallic plate or frame having on each side of its centre transverse slotted openings, the upper ends of which are larger than the lower ends thereof and the outer edges of which are curved inwardly, said plate being adapted to be folded centrally, substantially as and for the purpose specified.

No. 56,113. Automatic Vehicle. (Voiture.)

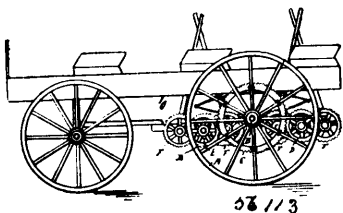

Aretas B. Andrews, Centre Point, Iowa, U.S.A., 3rd June, 1897; 6 years. (Filed 29th April, 1897.)

Claim.—In an automatic vehicle and motor power, the combination with geared carrying-wheels attached to a revolving shaft or axle, a plurality of spring actuated cylinders and a double train of gearing connecting them with the carrying-wheels, one train to give positive and forward motion, and the other to give intermittent backward motion to the cylinders, one or more pinions adapted to slide in and out of mesh with the intermittently-moving, winding-gears, and an automatic shifter therefor consisting essentially of a screw-threaded shaft *j*, a nut *J*¹ mounted thereon, a spring *j*¹ connecting it with a stirrup *U*, and angled stirrup *U*¹ to shift the said pinion in and out of mesh, and a spring actuated plunger *V*, with an angled head engaging the angled portion of said stirrup, substantially as described.

No. 56,114. Car Fender. (Défense de chars.)

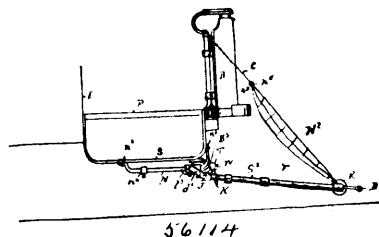

Henry Burden, Troy, New York, U.S.A., 3rd June, 1897; 6 years. (Filed 29th April, 1897.)

Claim.—1st. The combination with the slide-boxes *C, C*, each provided with a slide *N*, attached to the under side of the car at each end of the latter and provided with an adjustable stop *n*⁴, each of said slide-boxes having depending sides, and intermediate pin or shaft *W*, and provided with a latch bar *I*, which at each of its ends connects with one of said slide-boxes, of the fender sides *S*² *S*², each provided with the U-form hook *J*, at its rear end, each adapted to hook onto one of the shafts or pins *W*, the tripping-shaft *T*, provided with bearings depending from the car-bottom, and having latches *L*, adapted to hook onto said latch-bar *I*, means for tripping the said shaft and a net which at its lower front end is connected to the outer end of the fender, and at its upper end connected by chains with the dashboard of the car, by which said fender may be attached and detached from each end of the car, and when attached to be held with its front end raised from the ground, substantially as shown and described. 2nd. In a car-fender, the combination with a slide-box provided with a slideway at each side of each end of the car, and having a latch-bar arranged to connect at each of its ends with one of said slide-boxes, of the fender-sides *S*² *S*², each provided with a hook *J*, adapted to connect with one of said slide-boxes, substantially as described, the tripping-shaft *T*, having bearings in which to turn depending from the car-bottom, and provided with a latch *L*, adapted to hook onto said latch-bar, and having a crank or turn lever *K*, the nose-piece *D*², having the slide rods *e*², provided with a spring *g*, and arranged in the fender sides, and a trigger *T*, whereby when said nose-piece is moved rearwardly, its slide-rod trigger will engage with the crank *K*, to turn the tripping-shaft *T*, so as to raise its latch from the bar *I*, and thus allow the fender at its front end to fall to the ground, substantially as shown and described. 3rd. In a car-fender, the combination with the fender-sides *S*² *S*², connected by the cross-bars *b*¹ and *b*², and each provided with a slide-rod *e*², of a spring-nose-piece *D*², connected at its ends to one of the slide-bars *e*², the slide-boxes *C, C*, each provided with a slide *N*, having the shaft or pin *W*, the U-form hooks *J*, on the rear end of the fender-sides, the tripping-shaft *T*, provided with the turn levers *K*, and latches *L*, the latching bar *I*, and the triggers *T*² *T*², each connected to one of the said slide-rods *e*² constructed and arranged to operate, substantially as and for the purposes set forth. 4th. In a latching and latch-tripping mechanism for car-fenders, the combination with a slide-box, having a slide at each side, and each end of the car, in which slide-boxes the rear ends of the fender sides make hook and journal, a latch-bar at each of its ends connected to one of said slide-boxes, a tripping-shaft provided with bearings in which to turn, and having latches adapted to hook onto and unlatch from off the latch-bar by the rotation of said tripping-shaft, a crank arm or turn lever on the latter by which it may be rotated, a nose-piece provided with a slide-rod in each of the frame sides, a trigger on the inner end of said slide-rods, whereby as the latter are moved rearwardly said trigger will engage with the crank on the tripping-shaft to rotate the same, and raise its latch from off the latch-bar, substantially as shown and described.

No. 56,115. Rail Joint. (Joint de rails.)

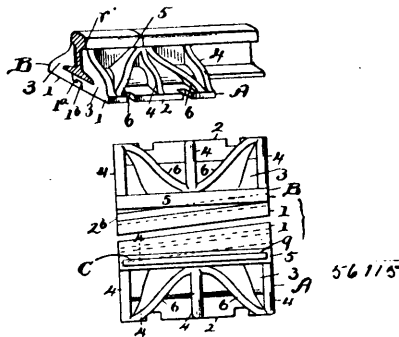

George D. Chaffin, jr., Toledo, Ohio, U.S.A., 3rd June, 1897; 6 years. (Filed 30th April, 1897.)

Claim.—1st. In a rail joint, the combination of the fixed and movable joint members, each having a base upon which the rails to be con-

ected rest, a body part which extends over the rail flanges and up to the balls of the rails, a longitudinal outwardly extended flange on the upper edge of said body which may engage beneath the balls of the rails, external vertical ribs, and diagonal truss ribs which are joined to the longitudinal flange at their upper ends, substantially as and for the purpose specified. 2nd. In a rail joint, the combination of the fixed and movable joint members, each having a base upon which the rails rest, a body part which extends over the rail flanges and up to the ball, a longitudinal outwardly extended flange on the upper edge of the body, a plurality of external vertical ribs which are formed on the body part and are joined at their upper ends to the said flange, and external diagonal truss ribs, which are joined at their upper ends to the flange and to one vertical rib, and at their lower ends respectively to the lower ends of the vertical ribs on both sides of said vertical rib, substantially as and for the purpose specified. 3rd. In a rail joint, the combination of the fixed and movable joint members, each having a base upon which the rails rest, a body part which extends over the flange of the rails and upward along side of the web of the rails, and an outwardly extended longitudinal flange on the upper edge of said member, one or both of said flanges having in its upper surface a longitudinal groove, and an electrical rail bond in said groove, substantially as and for the purpose specified.

No. 56,116. Sieve for Threshing Machines.
(*Crible pour machines à battre.*)

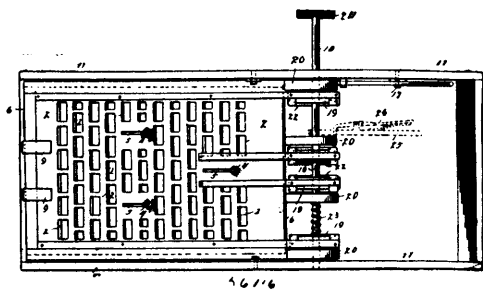

William Bartelt, Fairfield, Washington, U.S.A., 4th June, 1897; 6 years. (Filed 29th April, 1897.)

Claim.—1st. A sieve or screen comprising overlying sections or parts slidably related and having corresponding and registering openings which are varied by relatively moving the sections, and one of the sections having other openings of smaller size intermediate of the main openings, substantially as and for the purpose described. 2nd. A sieve or screen comprising overlying slidable sections or parts having corresponding openings and adapted to have the size of the openings varied by relatively moving the sections, and lips extending from the upper section and projecting through the openings of the lower section to extend across the joint between the two sections and provide lips therefor, substantially as set forth. 3rd. A sieve or screen comprising overlying slidable sections or parts having corresponding openings, lips projecting from the lower section, and other lips extending from the upper section and projecting through the openings of the lower section to overlap the joint formed between the sections and act jointly with the lips of the lower section, substantially as and for the purpose set forth. 4th. The combination with a sieve or screen comprising relatively movable sections or parts having corresponding openings, of a longitudinally-movable shaft, pinions secured upon the shaft, rack-bars having connection with the movable screen-section and meshing with the pinions, and a locking mechanism for securing the parts in an adjusted position and engaged and disengaged by a longitudinal movement of the shaft, substantially as set forth. 5th. In combination, a frame provided with a screen composed of overlying sections slidably related and having corresponding openings, means for supporting the frame at one end and serving to relatively adjust the sections, keepers at the opposite end of the frame, a crank-shaft having its horizontal portion operating in the said keepers, a rod having connection with an arm of the crank-shaft and extending within convenient reach to be operated for varying the inclination of the frame, and means for securing the said rod and holding the frame in the adjusted position, substantially as described.

No. 56,117. Military Hair Brush. (*Brosse à cheveux.*)

George William Glover, New York, State of New York, U.S.A., 4th June, 1897; 6 years. (Filed 28th April, 1897.)

Claim.—The herein described military brush, consisting of a handleless brush back hollowed out to provide a comb receptacle in its top portion, the side walls and one end wall of said receptacle being undercut to provide a continuous groove 6 below the top surface of the brush back, the opposite end of the brush back being

cut away between the side walls 5 of the receptacle 3 from the edge of the end wall of said receptacle to the edge of the brush back and to a plane in line with the base of the continuous groove 6, a sliding cover 7 adapted to enter and be removed from the brush back through the passageway provided by the cut-away portion of the brush back, said cover being bevelled as at 8, continuously

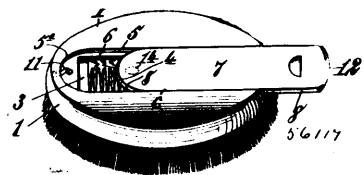

along its two side edges and one end to provide a tongue to fit the continuous groove 6 of the brush back, a spring finger secured to the brush back at the end opposite the cut-away portion and arranged in the path of the underside of the cover, and a seat in the underside of the sliding cover to receive said spring finger and retain the cover in closed position, substantially as described.

No. 56,118. Concentrating or Separating Machine.
(*Machine à concentrer ou séparer.*)

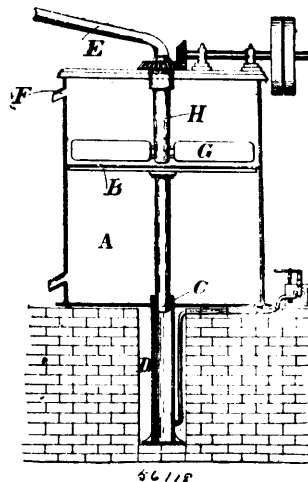

Walter Palmer Wynne and Thomas Tregartha, both of Ballarat, Victoria, Australia, 4th June, 1897; 6 years. (Filed 28th April, 1897.)

Claim.—1st. A concentrating or separating machine having an adjustable false bottom capable of being gradually lowered, substantially as and for the purposes herein described. 2nd. In a concentrating or separating machine, a set of rotatable arms or stirrers in combination with an adjustable false bottom capable of being gradually lowered, substantially as and for the purposes herein described.

No. 56,119. Switch Tongue Thrower.

(*Aiguilleur pour chars de rue.*)

David Mersereau Allen and William P. Ferries, both of Melrose Park, Illinois, U.S.A., 4th June, 1897; 6 years. (Filed 28th April, 1897.)

Claim.—1st. In a switch thrower, the combination with a casing or housing provided with an inverted U-shaped slot, of a depressible rod movable in said casing and provided with an operating handle adapted for movement in the slot, a disc-wheel journaled to the lower end of the rod, and a coil spring encircling the rod and interposed between the lower end of the casing and the operating handle, being adapted to normally raise the rod. 2nd. In a switch thrower, the combination with a switch tongue and a bracket fastened thereto, said bracket having an upwardly extending portion which reaches up above the tongue, of a casing provided with an inverted U-shaped slot, a removable cap for the casing, a rod removable vertically in the casing and provided with an operating

handle that is adapted for movement in the slot, the lower end of said rod being formed into a fork, a disc-wheel which is straddled

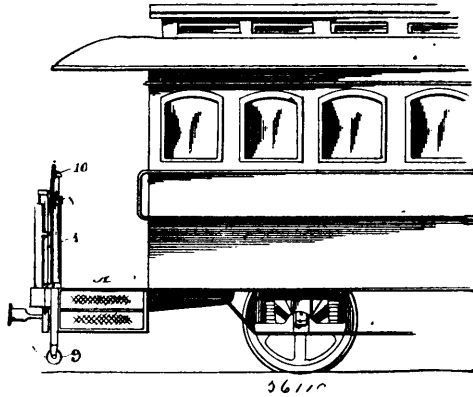

by the fork and is journaled thereto, and a coil spring bearing against the bottom of the casing and pressing against the operating handle, said spring being adapted to keep the rod normally elevated.

No. 56,120. Apparatus for Reclaiming Crystallized Syrups. (*Appareil pour dissoudre les sirops cristallisés.*)

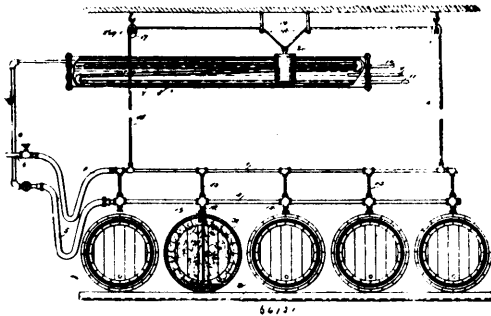

Edward Davis Smythe, New York, State of New York, U.S.A., 4th June, 1897; 6 years. (Filed 18th February, 1897.)

Claim.—1st. An apparatus for reclaiming crystallized syrup from original packages, comprising a steam inlet pipe, a steam outlet pipe, a nipple on the outlet pipe, a bushing adjustable on the nipple and adapted for engagement in the bung hole of the barrel, an injecting tube extended from the steam inlet pipe through the nipple and designed to extend nearly to the bottom of a barrel, and a counterbalancing mechanism for assisting in raising the several pipes, substantially as specified. 2nd. An apparatus for reclaiming crystallized syrup from barrels, comprising a steam inlet pipe and steam outlet pipe, a flexible connection between the steam inlet pipe and the steam supply pipe, a condenser, a flexible connection between the outlet pipe and said condenser, steam injecting tubes extended from the steam inlet pipe to the steam outlet pipe and designed to pass downward into barrels, nipples on the outlet pipe, bushings having screw thread engagement with said nipples and adapted to engage in the bungholes of barrels, a rope extended from the apparatus through pulleys secured to an overhead support, and a counterbalance connected with said rope, substantially as specified.

No. 56,121. Vehicle Wheel and Brake. (*Roue et frein de voitures.*)

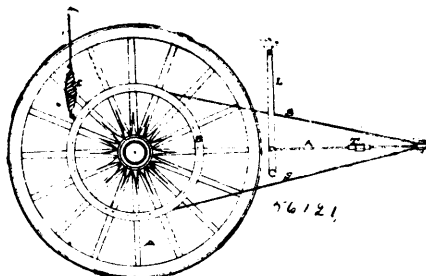

Thomas Spelman, Halifax, Nova Scotia, Canada, 4th June, 1897; 6 years. (Filed 22nd February, 1897.)

Claim.—A brake attachment to a wheeled vehicle of any kind comprising a brake wheel B, strap S, lever C, adjustable rod R, and

foot lever L, for applying power to said brake strap, all formed, arranged, combined and operated substantially as and for the purpose hereinbefore set forth.

No. 56,122. Woven Wire Fencing Apparatus.

(*Appareil pour faire les clôtures en tissus métalliques.*)

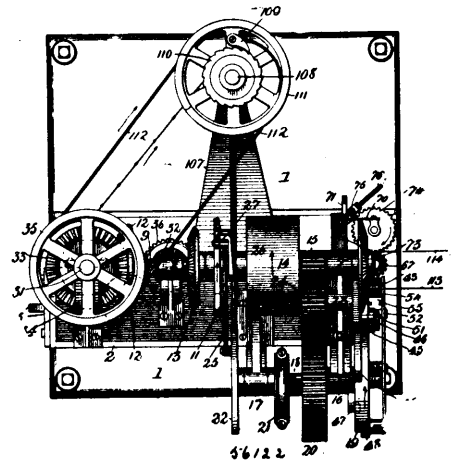

Albert James Bates, Joliet, Illinois, U.S.A., 4th June, 1897; 6 years. (Filed 22nd February, 1897.)

Claim.—1st. In a wire fence machine, the combination of mechanism for intermittently feeding a plurality of longitudinal strand wires, mechanism for intermittently feeding a plurality of stay wires, mechanism for cutting off suitable lengths of the stay wires to span the spaces between the strand wires, and mechanism for simultaneously coiling the adjacent ends of the lengths of the stay wires around the strand wires. 2nd. In a wire fence machine, the combination of mechanism for intermittently feeding a plurality of longitudinal strand wires, mechanism for intermittently feeding a plurality of stay wires transversely of the strand wires, mechanism for cutting off suitable lengths of the stay wires to span the spaces between the strand wires, and mechanism for intercoiling the adjacent ends of the lengths of the stay wires around the strand wires. 3rd. In a wire fence machine, the combination of mechanism for intermittently feeding a plurality of longitudinal strand wires, mechanism for intermittently feeding a plurality of stay wires in line with one another transversely of the strand wires, mechanism for cutting off suitable lengths of the stay wires to span the spaces between the strand wires, and mechanism for intercoiling the adjacent ends of the lengths of the stay wires around the strand wires. 4th. In a wire fence machine, the combination of mechanism for intermittently feeding a plurality of longitudinal strand wires, mechanism for intermittently feeding a plurality of stay wires in line with one another transversely of the strand wires, mechanism for cutting off suitable lengths of the stay wires to span the spaces between the strand wires, mechanism for coiling the outer ends of the outermost lengths of the stay wires around the border strand wires, and mechanism for intercoiling the adjacent ends of the lengths of the stay wires around the intermediate strand wires. 5th. In a wire fence machine, the combination of mechanism for intermittently feeding a plurality of longitudinal strand wires, mechanism for intermittently feeding a plurality of stay wires transversely of the strand wires, mechanism for cutting off suitable lengths of the stay wires to span the spaces between the strand wires, mechanism for crimping the strand wires at the junction of the stay wires to more firmly secure the latter. 6th. In a wire fence machine, the combination of mechanism for intermittently feeding a plurality of longitudinal strand wires, mechanism for intermittently feeding a plurality of stay wires transversely of the strand wires, mechanism for cutting off suitable lengths of the stay wires to span the spaces between the strand wires, mechanism for intercoiling the adjacent ends of the lengths of the stay wires around the strand wires, and mechanism for taking up the fencing as it is formed. 7th. In a wire fence machine, the combination of a plurality of coilers through which longitudinal strand wires are fed, a plurality of guides through which stay wires are fed transversely to the coilers, mechanism for cutting off suitable lengths of the stay wires to span the spaces between the strand wires, and mechanism for holding the stay wires intermediately of the coilers while their ends are being coiled around the strand wires. 8th. In a wire fence machine, the combination of a plurality of coilers through which longitudinal strand wires are fed, a plurality of guides through which stay wires are fed transversely to the coilers, mechanism for cutting off suitable lengths of the stay wires to span the spaces between the strand wires, and guides adapted to hold the cut lengths of the stay wires intermediately of the coilers while their ends are being coiled around the strand wires, and to

yield so as to release the stay wires after the coiling operation. 9th. In a wire fence machine, the combination of a plurality of coilers through which longitudinal strand wires are fed, a plurality of guides through which transverse stay wires are fed to the coilers, mechanism for feeding in the stay wires transversely of the strand wires, and mechanism for cutting off suitable lengths of the stay wires to span the spaces between the strand wires, said feeding and cutting mechanisms being arranged and adapted to feed the stay wires in and cut them off with the ends of adjacent lengths over-lapping at the coilers. 10th. In a wire fence machine, the combination of a plurality of coilers through which longitudinal strand wires are fed, mechanism for feeding a plurality of stay wires transversely of the strand wires, mechanism for cutting off suitable lengths of the stay wires to span the spaces between the strand wires, and mechanism for rotating the coilers in one direction only to coil the ends of the stay wires around the strand wires. 11th. In a wire fence machine, the combination of a plurality of coilers through which longitudinal strand wires are fed, mechanism for feeding stay wires to the coilers transversely of the strand wires, mechanism for cutting the stay wires, mechanism for intermittently rotating the coilers in one direction only, and mechanism for locking the coilers against rotation during the intermission of their rotation. 12th. In a wire fence, the combination of a plurality of coilers through which longitudinal strand wires are fed, mechanism for feeding stay wires to the coilers transversely of the strand wires, mechanism for cutting the stay wires, a rack and gear mechanism for rotating the coilers in one direction only, and mechanism for throwing said rack into and out of engagement. 13th. In a wire fence machine, the combination of a plurality of coilers through which longitudinal strand wires are fed, mechanism for feeding stay wires to the coilers transversely of the strand wires, a rack and gear mechanism for intermittently rotating the coilers in one direction only, mechanism for throwing said rack into and out of engagement, and means for locking and holding the coilers while the rack is out of engagement, so as to prevent rotation and insure the re-engagement of the rack. 14th. In a wire fence machine, the combination of a plurality of coilers arranged in line with one another, a rack and gear mechanism for rotating said coilers, said rack being supported in parallel relation with the line of coilers by pivoted levers, and mechanism for swinging the levers to throw the rack into and out of engagement. 15th. In a wire fence machine, the combination of a plurality of coilers arranged in line with one another, a gear rack for rotating said coilers, a rack supporting bar, pivoted levers carrying said bar, a rod connecting said levers, mechanism for swinging the levers to throw the bar and its rack toward and from the coilers, and mechanism for reciprocating the rack. 16th. In a wire fence machine, the combination of a plurality of coilers arranged in line with one another, the gear-rack 55 supported in parallel relation with the line of coilers on pivoted levers 44, 45, the rod 50 connecting said levers to move together, and the cam-wheel 19 upon which the rollers 46, 47 of the lever 45 work. 17th. In a wire fence machine, the combination of a plurality of coilers, arranged in line with one another, the gear-rack 55 supported in parallel relation with the line of coilers on pivoted levers 44, 45, the rod 50 connecting said levers to move together, the cam-wheel 19 upon which the rollers 46, 47 of the lever 45 work, the lever 57 pivotally connected to the rack-bar and to the connecting rod 59, and the rod 61 connecting the lever 57 to the crank 62 of the cam-wheel. 18th. In a wire fence machine, the combination of a plurality of coilers arranged in line with one another and provided with pinions, a reciprocating rack-bar in parallel relation with said line of coilers and adapted to be thrown laterally into and out of engagement with said pinions, a keeper-plate movable laterally with the rack-bar, and pins 53 on the said plate at the side of the coiler pinions opposite from the bar. 19th. In a wire fence machine, the combination of a plurality of coilers through which longitudinal strand wires are fed, guide tubes corresponding to the coilers for feeding transverse stay wires thereto, and intermediate guides located between the coilers for directing the stay wires from one coiler across the intervening space to the next adjacent coiler. 20th. In a wire fence machine, the combination of a plurality of coilers through which longitudinal strand wires are fed, guides extending between the coilers for directing the stay wires from one coiler across the intervening space to the adjacent coiler, and cutters for cutting the stay wires after they have been projected through the said guides, said guides being adapted to hold the stay wires during the operation of the coilers and to release them after the coiling is completed. 21st. In a wire fence machine, the combination of a plurality of coilers through which longitudinal strand wires are fed, co-operating rolls for feeding stay wires through the coilers transversely of the strand wires, and mechanism for throwing some of the feed rolls out of action, so as to interrupt the feeding-in of some of the stay wires. 22nd. In a wire fence machine, the combination of a plurality of coilers through which longitudinal strand wires are fed, the shaft 67 carrying feed rolls 59, one for each coiler, the co-operating feed rolls 72 mounted in spring arms and geared to the rolls 69, and means for throwing the rolls 72 into and out of operative connection with the rolls 69. 23rd. In a wire fence machine, the combination of the driven feed rolls 69, the co-operating rolls 72 geared to the rolls 69, the spring arms 70 in which the rolls 72 are mounted, and the cam-faced levers 76 for throwing the rolls 72 into operative connection with the rolls 69. 24th. In a wire fence machine, a stay wire feeding mechanism includ-

ing suitably driven pairs of feed rolls 59, 72, one roll of each said pair making one complete rotation in a plurality of operations and having a portions of its periphery cut away corresponding with its movent at one operation, whereby the feeding action will be omitted at intervals as described. 25th. In a wire fence machine, the combination of strand wire feeding mechanism, stay wire feeding mechanism, and stay wire cutting and coiling mechanism, with mechanism for crimping the strand wires at the junction of the stay wires, said mechanism consisting of rolls between which the completed fencing passes, one of said rolls having a plain surface and the other being provided with notches or recesses into which the coils of the stay wire pass. 26th. In a wire fence machine, the combination of strand wire feeding mechanism, stay wire feeding mechanism, mechanism for cutting the stay wires and for coiling them around the strand wires, the tension roll 99 having a plain periphery, and the take-up roll 93 having notches or recesses 94 in its periphery, the surface of the rollers 99 and 93 being in such proximity that the strand wires are crimped at the junction of the stay wire coils as the coils pass into the recesses 94. 27th. In a wire fence machine, the combination of a plurality of coilers, a stationary cutter-bar, carrying a plurality of cutters corresponding to the coilers, a movable cutter-bar carrying a plurality of cutters corresponding to and co-operating with the fixed cutters, and mechanism for moving the movable cutter-bar toward and from the stationary bar to operate all the cutters simultaneously. 28th. In a wire fence machine, the combination of a plurality of coilers, a stationary cutter-bar carrying a plurality of cutters corresponding to the coilers, and a movable cutter bar carrying a plurality of cutters corresponding to and co-operating with the fixed cutters, said movable bar being mounted on eccentric wrists 82 of a pair of levers 83, 84, connected together by a rod 87, and means for operating the levers. 29th. In a wire fence machine, the combination of take-up rolls for taking up the completed fencing, tension rolls co-operating with said take-up rolls, spring arms in which the tension rolls are mounted, and cam-faced levers for throwing the tension rolls into operative connection with the take-up rolls. 30th. In a wire fence machine, the combination of strand wire feeding mechanism, stay wire feeding mechanism, mechanism for cutting the stay wires and coiling them around the strand wires, mechanism for taking up the completed fencing, and differential gearing for driving the take-up mechanism, whereby the intervals between the stay wires may be varied. 31st. In a wire fence machine, the combination of the shafts 30, 31, of the take-up mechanism, said shafts being interguarded by the gears 36 and 37 respectively, and the idler 38 of the drive shaft 9 having the adjustable gears 12 and 13 adapted to mesh with the gears 32 and 33 on the shafts 30 and 31 respectively. 32nd. In a wire fence machine, the combination of a winding drum, a ratchet wheel fixed on the shaft of the drum, a driving wheel loosely journaled on said shaft, and a pawl carried by the driving wheel and engaging the ratchet wheel. 33rd. In a wire fence machine, the combination of a longitudinally sectional winding drum, a driven head-piece in which the ends of the drum sections are fitted, a rotatable stand in which the other ends of the drum sections are fitted, and means for releasably securing said sections together and to the head and stand. 34th. In a wire fence machine, the combination of a driven head-piece 105, the rotary stand 101, the longitudinally sectional winding drum composed of the parts 100, 100, and the detachable fastening pieces 102 and 104. 35th. In a wire fence machine, the combination of a plurality of coilers through which the longitudinal strand wires are fed, a plurality of guides through which stay wires are fed to the coilers transversely of the strand wires, mechanism for feeding the stay wires through the guides, and mechanism for cutting off suitable lengths of the stay wires to span the spaces between the strand wires, said wires being curved so as to present the ends of the stay wires at an angle to the face of the coilers in order that the body position of the wires may not interfere with the action of the coiling pins. 36th. In a wire fence machine, the combination of a plurality of coilers arranged in vertical line one over another, a plurality of similarly arranged guides and feed rolls for feeding the stay wires to the coilers, take-up rolls for taking the fencing from the coilers, and a winding drum for reeling the completed fencing, said take-up rolls and winding drum being located and arranged in parallel relation to the lines of coilers and stay wire feed-rolls. 37th. In a wire fence machine, the combination of bed and head-plates suitably connected by vertical standards, a plurality of coilers arranged in vertical line one over another, a vertically reciprocating rack-bar in parallel relation with the line of coilers, a plurality of vertically arranged guides and feed rolls for directing and feeding stay wires to the coilers, and take-up and tension rolls for taking the fencing from the coiling, said take-up rolls being located and arranged vertically in parallel relation to the line of coilers.

No. 56,123. Pea Harvester. (Machine à récolter les pois.)

George Wettlaufer, Stratford, Ontario, Canada, 4th June, 1897; 6 years. (Filed 27th February, 1897.)

Claim.—(1st. The combination, with a finger bar, and its outside shoe D, provided with a slot and serration e, longitudinally adjustable upright b, provided with serrations engaging with the serrations on the shoe, and having a vertical slot and serrations on its side a, serrated block d, secured to the shoe D, and engaging with

the said serrations on the side of the upright *b*, an upright *c*, secured to the shoe *D*, and provided with a vertical slot, and serrations on

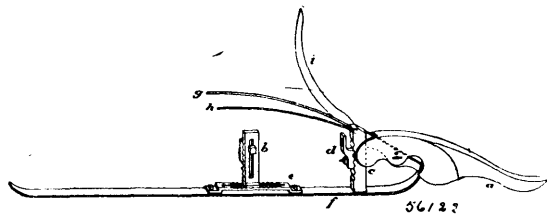

its side, a block *d*, provided with a hole engaging with the point of the guard on the cutterbar, and serrations engaging with the serrations on the upright *c*, and bolts securing the block *d*, to the upright *C*, and the upright *C*, to the shoe *D*, substantially as set forth. 2nd. The combination, of the cutterbar and its inside shoe *E*, with ratchet arm and wheel, perforated shoe plate *m*, pin *l*, substantially as set forth. 3rd. The combination of the cutterbar and the rods *o*, fastened as shown in figure 4, with the rod *p*, with the knife *i*, and the rods *g*. and *h*, substantially as set forth.

No. 56,124. Signal Lantern. (Signal avec feux.)

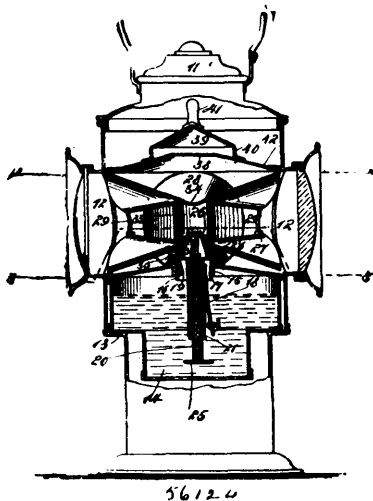

Willard Richardson Dodson, Jermyn, Pennsylvania, U.S.A., 4th June, 1897; 6 years. (Filed 5th March, 1897.)

Claim.—1st. In a signal lantern, a casing, an oil receptacle within the casing, a burner having a conical shield, a transparent chimney-tube, two horizontal disc-like reflector sections centrally orificed and having the chimney-tube located between them and aligned with the orifices, and a second shield rigidly secured to the lower reflector-section and embracing the first shield, substantially as described. 2nd. In a signal lantern, an oil receptacle, the same having an opening in its upper side, a tube having a flange, the tube being passed through the opening and supported on the oil receptacle through the medium of the flange, a conical shield on the flange, a second tube movable within the first tube, a needle passing through the first tube and into the second tube and capable of locking the latter, and a wick passed through the second tube and conical shield, substantially as described. 3rd. In a signal lantern, a casing, an oil receptacle within the casing, a burner, horizontally disposed reflector-sections, and spring pressed bolts carried by the reflector-sections and locking with the casing, substantially as described. 4th. In a lantern, an oil receptacle having an opening therein, a tube projected through the opening and held with its upper end out of the receptacle, a spring arm fixed to the tube, a needle movable transversely through the tube and actuated by the arm, a second tube reciprocated through the first tube, the second tube being longitudinally perforated, and a wick held in the second tube, substantially as specified. 5th. In a lamp, the combination of two disc-like reflector-sections, the same being extended in approximately parallel planes and having central openings therein, a transparent chimney tube engaging at its respective ends the reflector-sections, and fastening devices at the outer portions of the sections, said devices tending to draw the sections together and to forcibly hold them against the chimney tube, substantially as described. 6th. In a lamp, the combination of two disc-like reflector-sections extending in approximately parallel planes, the sections having matched waved portions forming outwardly flaring light radiating passages and being centrally perforated, a transparent chimney tube engaging at its respective ends the reflector-sections and held between the same, and fastening devices at the outer portions of the reflector-sections whereby the sections are moved together and forced against the chimney tube, substantially

as described. 7th. In a lantern, the combination with a casing and its oil receptacle, of a burner, two horizontal reflector-sections centrally perforated, a chimney tube held between the sections, and a shield superposed on the upper reflector-section and contained within the casing, the said shield being centrally orificed and having a dome plate held to cover said orifice, substantially as described.

No. 56,125. Wrench. (Clé à écrou.)

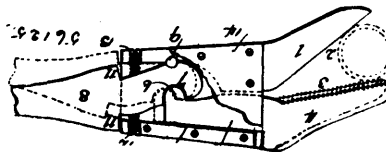

John Elmer Wood, Beverly, Mass, U.S.A., 4th June, 1897; 6 years. (Filed 15th March, 1897.)

Claim.—1st. In a wrench, the combination with a pair of jaws, the inner surfaces of which converge with relation to each other, and one jaw rigid, and the other non-pivotal and movable endwise or longitudinally with relation to the other, of a handle for operating said movable jaw, substantially as set forth. 2nd. In a wrench, the combination with two jaws, one of which is non-pivotal and movable endwise, of a handle pivoted to one jaw and connected with the other so as to pull endwise upon and move the movable jaw in the direction in which the latter is swung by the movement of the wrench. 3rd. In a wrench, the combination with a fixed jaw and a casing connected therewith, of a longitudinally-movable jaw having a shank which fits and slides within the casing, a handle pivoted within the casing and constructed and adapted to impart a longitudinal sliding movement to the movable jaw, and a spring located within the casing and arranged to bear upon the opposite sides of the handle-lever at a point in rear of its pivotal bearing, substantially as set forth.

No. 56,126. Filter. (Filtre)

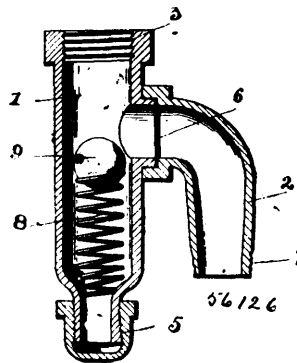

Samuel Henry Jones, Scranton, Pennsylvania, U.S.A., 4th June, 1897; 6 years. (Filed 27th March, 1897.)

Claim.—1st. A filter, made up of a casing adapted to be screwed upon an ordinary faucet having an opening in its lower end, a spout extending outwardly from the upper end of said casing, a filtering screen therein, and a cap normally fitting upon the lower end of said casing and adapted to be screwed upon the lower end of said spout, substantially as and for the purpose described. 2nd. A filter, made up of a casing adapted to be screwed upon an ordinary faucet having an opening at its lower end, a spout extending outwardly from the upper end of said casing, a filtering screen therein, a cap normally fitting upon the lower end of said casing and adapted to be screwed upon the lower end of said spout, and means located in said casing for preventing the direct impact of the water from the faucet with the bottom thereof, but permitting the free passage of said water therethrough. 3rd. A filter, made up of a casing adapted to be screwed upon an ordinary faucet having an opening at its lower end, a spout extending outwardly from the upper end of said casing, a filtering screen therein, a cap normally fitting upon the lower end of said casing, and a ball loosely mounted upon the upper end of said spring, whereby the direct impact of the water against the bottom of said casing is prevented, but free passage of the same therethrough is permitted.

No. 56,127. Machine for Grinding and Polishing Plate Glass. (Machine pour polir les surfaces.)

Phillip Semmer, Pittsburg, Pennsylvania, U.S.A., 4th June, 1897; 6 years. (Filed 16th March, 1897.)

Claim.—1st. A machine for grinding and polishing plane sheets of glass and other plane surfaces, consisting of a horizontal cylinder adapted to receive the glass, the glass resting on edge in the cylinder, and a cushion located in the said cylinder, said cylinder having a

revolving motion. 2nd. A machine for grinding and polishing plane sheets of glass and other plane surfaces, consisting of a cylinder

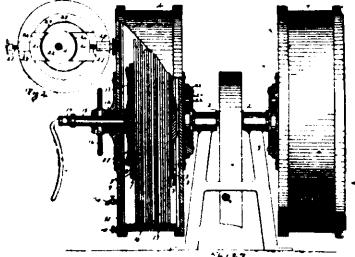

adapted to receive the glass, and a cushion located in said cylinder, said cushion being secured to the cylinder at intervals and between the intervals extending towards the centre of the cylinder. 3rd. A machine for grinding and polishing plane sheets of glass and other plane surfaces, consisting of a horizontal cylinder adapted to receive the glass and perpendicularly arranged grinding discs located in said cylinder, said cylinder having a revolving motion. 4th. A machine for grinding and polishing plane sheets of glass and other plane surfaces, consisting of a horizontal cylinder adapted to receive the glass, the glass being adapted to rest on edge in the cylinder, and a removable side closing one end of the cylinder, and perpendicularly arranged grinding discs located in said cylinder, said cylinder having a revolving motion. 5th. A machine for grinding and polishing plane sheets of glass and other plane surface, consisting of a horizontal cylinder adapted to receive the glass, the glass resting on edge in the cylinder, a perpendicular grinding disc permanently secured to one end of the cylinder, and a grinding disc perpendicularly arranged and adjustably secured to the opposite end of the cylinder, said cylinder having a revolving motion. 6th. A machine for grinding and polishing plane sheets of glass and other plane surfaces, consisting of a cylinder adapted to receive the glass, and a laterally adjustable grinding disc secured to one side of the cylinder, said cylinder having a revolving motion. 7th. A machine for grinding and polishing plane sheets of glass and other plane surfaces, consisting of a cylinder adapted to receive the glass and a laterally adjustable grinding disc secured to one side of the cylinder, and a device for retaining said disc in a desired position, said cylinder having a revolving motion. 8th. A machine for grinding and polishing plane sheets of glass and other plane surfaces, consisting of a horizontal cylinder adapted to receive the glass, the glass resting on edge in the cylinder and a cushion in said cylinder, said cushion consisting of an elastic belt, elastic sections transversely arranged and interposed between said belt and cylinder, said cylinder having a revolving motion. 9th. A machine for grinding and polishing plane sheets of glass, and other plane surfaces, consisting of a horizontal cylinder adapted to receive the glass, the glass resting on edge in the cylinder, said cylinder adapted to receive a suitable liquid and abrasive, buckets located within said cylinder and adapted to elevate the liquid and abrasive, and deposit the same on the upper edge of the glass, said cylinder having a revolving motion. 10th. A machine for grinding and polishing plane sheets of glass and other plane surfaces, consisting of a horizontal cylinder adapted to receive the glass, the glass resting on edge in the cylinder, a cushion located within the cylinder, buckets located within the cylinder on each side of the cushion, said cylinder adapted to hold a liquid and an abrasive, said buckets adapted to elevate the liquid and abrasive and deposit the same on the upper edge of the glass, said cylinder having a revolving motion. 11th. A machine for grinding and polishing plane sheets of glass and other plane surfaces, consisting of a horizontal cylinder adapted to receive the glass, the glass resting on edge in the cylinder, said cylinder having an opening in one end, an arm protruding through said opening and a disc secured to the inner end of said arm, said cylinder having revolving motion. 12th. A machine for grinding and polishing plane sheets of glass and other plane surfaces, consisting of a horizontal cylinder adapted to receive the glass, the glass resting on edge in the cylinder, said cylinder having at one end an opening, a shifting arm protruding through said opening, a suitable device adapted to shift said arm and retain it in a desired position, a disc secured to the inner end of the said arm, said cylinder having a revolving motion. 13th. A machine for grinding and polishing plane sheets of glass and other plane surfaces, consisting of a horizontal cylinder adapted to receive the glass, the glass resting on edge in the cylinder, pulleys arranged under said cylinder, said cylinder resting on said pulleys, said cylinder having a revolving motion.

No. 56,128. Tin Can Testing Machine.

(Appareil à faire l'épreuve des boîtes métalliques.)

Otto Asche, Paris, France, 4th June, 1897; 6 years. (Filed 6th April, 1897.)

Claim.—1st. The process herein described, of testing the perfect air-tightness of closed and filled conserving tins or other cans, which consists in swelling or convexing the bottoms of the conserving tins or cans (making use for that purpose of their elasticity) so as to produce in the inside of the tins or cans a partial vacuum and to

cause a rush of outward air into the conserving tins or cans, which are not air-tight, substantially as set forth. 2nd. The process herein described, of testing the perfect air-tightness of filled and closed conserving tins or other cans, which consists in swelling or convexing the bottoms and simultaneously the covers of the conserving tins or cans (making use for that purpose of their elasticity) so as to produce in the inside of the tins or cans a partial vacuum, and to cause a rush of outward air into the tins or cans which are not air-tight, substantially as set forth. 3rd. The process herein described, of testing the perfect air-tightness of filled and closed conserving tins or other cans, which consists in swelling or convexing one or any part of the bodies of the conserving tins or cans (making use for that purpose of their elasticity) so as to produce in the inside of the tins or cans a partial vacuum, and to cause a rush of outward air into the tins or cans, which are not air-tight, substantially as set forth.

No. 56,129. Machine for Smoothing the Edges of Cuffs and Collars. (*Fer à lisser les rebords des poignets et collets.*)

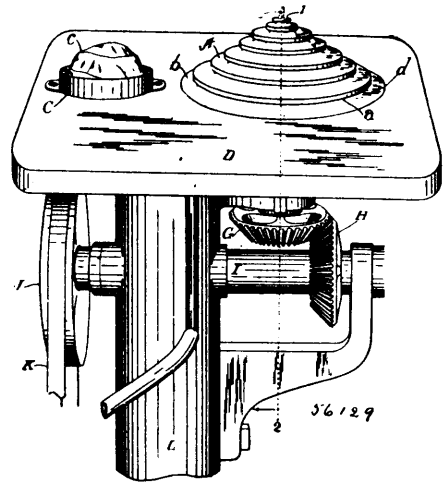

Fred E. Fay, Los Angeles, California, U.S.A., 4th June, 1897; 6 years. (Filed 12th April, 1897.)

Claim.—1st. The combination of a vertical rotating shaft, means for rotating the shaft, a circular head fixed on the top of such shaft and being solid and stepped on its upper face and having around the steps respectively a peripheral groove, and the heating appliance arranged beneath the head to heat it. 2nd. In an ironing machine for smoothing the edges of cuffs and collars, the cone shaped revolving head having its upper face stepped and provided with peripheral grooves around the steps respectively. 3rd. In ironing machine, comprising a circular rotating head having a peripheral groove, the walls of which are adapted to be heated and to smooth the cuff or collar at its edge, and the lower wall of which groove is wider than the upper wall and projects to form a stop, rest and guide for the cuffs and collars. 4th. In a machine for ironing the edges of collars, a circular rotary head having its upper face stepped and provided with peripheral grooves and terminating at the top in a button or knob having a small neck to approximately fit into the internal angles of the collar, substantially as and for the purpose set forth. 5th. The machine for smoothing the edges of cuffs and collars, provided with a vertical rotating shaft and a gas burner arranged near such shaft, and a solid circular head having its upper face stepped and provided with peripheral grooves, and in its under side a central socket to fit the upper end of the shaft, and an annular groove to receive the flame from the gas burner.

No. 56,130. Dyeing Apparatus.

(Appareil pour teindre.)

Ernest Thomas, Lengenfeld, Germany, 4th June, 1897; 6 years. (Filed 12th April, 1897.)

Claim.—1st. Dyeing apparatus, comprising a vat, a perforated cage therein, pipe connections from the bottom to the top of the vat, and steam pipe having a nozzle passing into said pipe connections, so as to cause a circulation of the liquid in the vat. 2nd. In a dyeing apparatus, the combination with the vat, of a perforated cage made to open to receive the material to be dyed, and steam pipe connections for circulating the liquid in the vat. 3rd. In a

dyeing apparatus, the combination of a vat, a perforated cage therein and steam pipes extending into said vat and having nozzles,

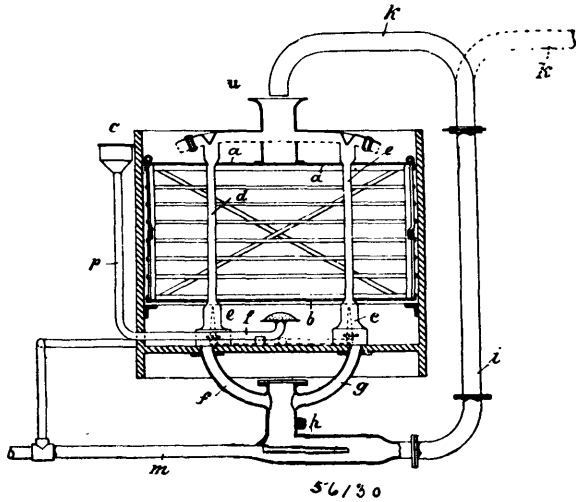

pipe connections from the bottom to the top of the vat, and a steam pipe having a nozzle extending into said vat, whereby the liquid in the vat may be circulated from either the inside or the outside or both.

No. 56,131. Machine for Constructing Twisted Wire Fabric. (*Machine pour la fabrication de tissus métalliques.*)

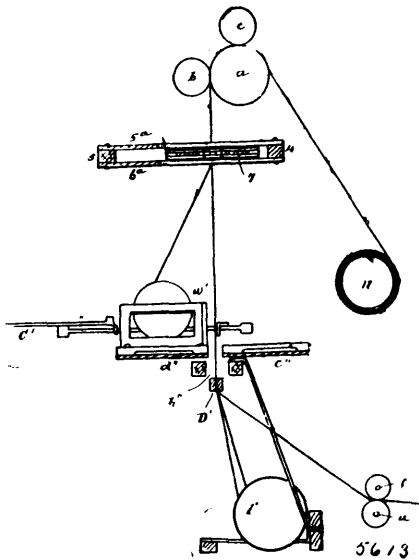

Frank B. Hart, Detroit, Michigan, U.S.A., 4th June, 1897; 6 years. (Filed 20th April, 1897.)

Claim.—1st. In a machine for constructing twisted wire fabric, the combination of twisters and means whereby they are operated, with shifting plates adapted to shift the wires of said fabric from one set of twisters to another, means for operating said shifting plates, means for preventing the wires of said fabric from being twisted below said twister plates, substantially as described. 2nd. In a machine for constructing wire fabric, wire twisting discs adapted to twist said wires, means for operating said wire twisters, wire shifting plates adapted to shift the wires of said fabric from one set to another of said twisters, means for operating said shifter plates, wire carrying spools adapted to carry one set of the wires of said fabric and to be operated longitudinally, a second set of stationary wire spools carried below said movable spools and adapted to carry the remaining set of wires of said fabric and a shifter bar adapted to engage said remaining set a point above said spools and below said movable spools and to shift said spools laterally across the path of said longitudinal moving spools, substantially as described. 3rd. In a wire twisting machine, the combination with a twisting mechanism, of two series of wire supply spools, a shifter bar adapted to shift the wires of one series and mechanism for operating said

shifter bar, one of said series of wire supply spools being stationary and the other movable, and means for operating said movable spools, and tension feed rollers adapted to feed stiffening wires and to keep them under tension while being operated upon, substantially as described. 4th. In a machine for twisting wire, the combination with a twisting mechanism of two series of wire supply spools, the spools of both series and the twister being placed at different distances apart, a shifter bar provided with a guide blocks for the wires and means for giving the said blocks different movements, substantially as described. 5th. In a machine for twisting wire, the combination with a twisting mechanism, of a supply spool, a roll adapted to support the rear face of the spool, and a fixed rest arranged to support the front face, substantially as described. 6th. In a wire twisting machine, the combination of a shifting bar D¹, a reciprocating spool carrier, twisting discs, and wire shifting plates, substantially as described. 7th. In a wire twisting machine, a reciprocating shifting bar provided with blocks m¹¹, n¹¹, o¹¹, in combination with means whereby the blocks m¹¹ and n¹¹ shall have a greater movement than blocks o¹¹, while block m¹¹ has a greater movement than n¹¹, substantially as described. 8th. In a wire twisting machine, the shifter bar D¹ provided with a rack M¹ supported in ways beneath the space b¹¹, in combination with the shaft K¹ carrying the pinion L¹ at its upper end and the five pointed wheel E¹ at its lower end, and the master-wheel B provided with studs constructed and operated, substantially as and for the purpose described. 9th. In a machine for constructing wire fabric, the plates c¹¹, d¹¹, provided with means for guiding the carrier frames and flanged spool carriers w¹, the arms B¹, C¹, crank-wheels Y, A¹, and shafts X, Z provided with gear-wheels at their lower ends, and adapted to be operated by the master-wheel B, and pinion S, substantially as and for the purpose set forth. 10th. In a wire twisting machine, the wire shifters 5^a, 6^a, slotted at 3 and bevelled on both sides as at 3 and secured in pairs to the upper and lower faces of the bars 4, 5, of the shifting frame, the combination with the twisting discs 12, the bars 12^a, arms 24, 25, upon the shaft D¹¹, said shaft being provided with the arm 23, the shaft A¹¹ provided with an arm 22, connecting rod 22^a, star-wheel B¹¹ mounted upon said shaft A¹¹ adapted to be operated by lugs C, C, carried upon gear m, means for operating said gear whereby motion is transmitted to the shifting plates, substantially as described. 11th. In a wire twisting machine, the feed rollers a, b, c, connected by gear-wheels and supported in bearings above the wire twisting discs, in combination with the ratchet-wheel e, pawl g pivoted to the arm f, the slotted rock arm i operated by the wrist pin of the crank-wheel l upon the end of the shaft n, a connecting rod s, the gear m mounted upon said shaft n, the pinion u upon the shaft p adapted to engage with said gear m and to be driven from the main pulley V, substantially as described. 12th. In a machine for constructing twisted wire fabric, the combination with a wire twisting mechanism, of feed rollers located above said twisters and adapted to take the constructed fabric from the said twisters and feed it to the reel, tension feeding rolls below said twisters adapted to feed stiffening wires and to keep them under tension while being operated upon and woven into said fabric, means whereby the feeding of said rolls may be adjusted and means for increasing the tension of the rolls, substantially as described. 13th. In a wire twisting machine, the expandible reel n¹ having its slats fixed to slotted sliding plates, and plats being secured to cross-arms upon the shaft of the reel, and operated by central nuts p¹ to expand and contract the circumference of the reel, substantially as described. 14th. In a wire twisting machine, the combination with a twisting mechanism and means for operating the same, the feed rollers a, b, c, ratchet e, lever f, pawl g, connecting rod s, tension feed rollers, ratchet e¹, lever g¹, rod r rock arm i and means for adjustably securing rods r and s to said rock arm,

No. 56,132. Nut Lock. (*Arrête-écrou.*)

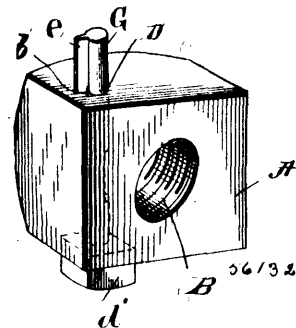

Clifford Cortland Cuyler, Arago, Oregon, U.S.A., 4th June, 1897; 6 years. (Filed 24th April, 1897.)

Claim.—1st. A nut-lock comprising the nut having the usual threaded opening, a key-passage-way extending through the nut transverse the threaded opening and passing through one side of the threaded opening and communicating therewith, of a key adapted to pass through the said key-opening and having at one end a fin, and intermediate its end a cut-away portion a distance from the

head equal to the distance from the outside of the nut to a central line drawn through the nut transverse the key, substantially as and for the purpose described. 2nd. A nut-lock comprising a nut having the usual threaded opening, a key-opening extending transverse the threaded opening and communicating therewith, a slit extending throughout the key-opening and at one side of the threaded opening, and a key having an intermediate cut-away portion for the purpose described, and a fin or projection at one end adapted to register with said slit, substantially as described. 3rd. A nut-lock comprising a nut having the usual threaded opening, a key-opening extending transversely the threaded opening and communicating therewith, a slit extending longitudinal the key opening, a key having an intermediate cut-away portion, at one end a head and at the opposite end a fin or projection adapted to engage the slit, the fin being a distance from the head equal to the width of the nut, whereby the turning of the key will lock the nut in position and also the key against removal, substantially as described.

No. 56,133. Garment Hanger. (Accroche-vêtement.)

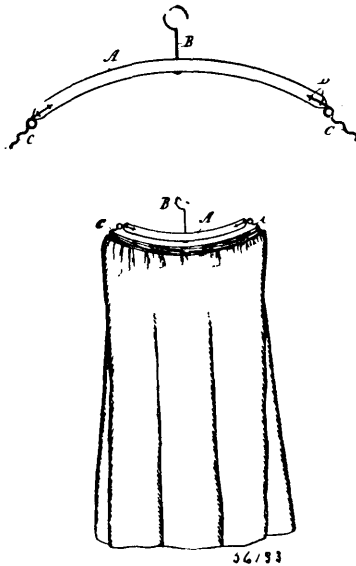

Ethel M. Bigsby, assignee of Herbert E. Cross, both of Detroit, Michigan, U.S.A., 4th June, 1897; 6 years. (Filed 26th April, 1897.)

Claim.—A garment hanger consisting of the herein described curved bar having outwardly bearing springs mounted on its ends substantially as and for the purposes specified.

No. 56,134. Concentrator. (Concentrateur.)

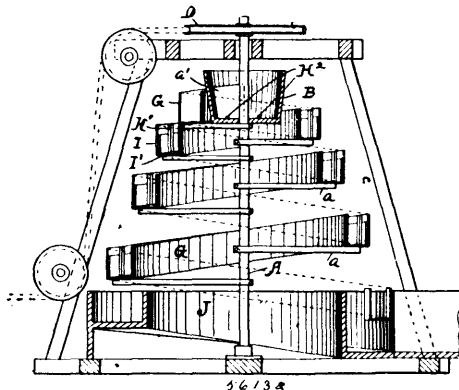

Clarence A. Holmes, Seattle, Washington, U.S.A., 4th June, 1897; 6 years. (Filed 26th April, 1897.)

Claim.—1st. In a concentrating device, the combination of a spiral flume having a downward incline from end to end, and means for rotating it about its central axis in a direction to retard the flow of the water therein, and means in said flume for arresting and holding the metallic particles, substantially as shown and described. 2nd. In a concentrating device, the combination of a spiral flume having a downward incline from end to end, and means for rotating

it about its central axis in direction to retard the flow of water therein, and riffles upon the bottom and sides of said flume, substantially as shown and described. 3rd. In a concentrating device, the combination of a hopper or box, and a side discharge opening therefrom, with a flume connected with said discharge opening and extending spirally, riffles and amalgamating plates on the sides and bottom of said flume, and means for rotating the flume in a direction to retard the flow of water therein, substantially as shown and described. 4th. In a concentrating device, the combination of a spiral flume having an incline from one end to the other, means for adjusting the amount of this incline, and means for rotating said flume in a direction to retard the flow of water therein, and means for arresting and holding the metal particles therein, substantially as shown and described. 5th. In a concentrating device, a hopper and a spiral flume, substantially as described.

No. 56,135. Endoscopic Instrument. (Instrument endoscopique.)

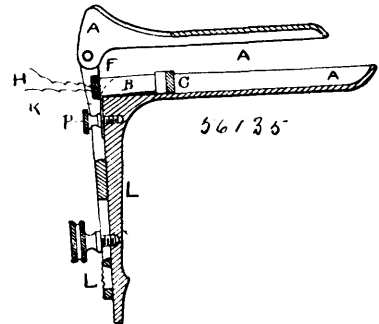

John Wesley Daily, Boston, Mass, U.S.A., 4th June, 1897; 6 years. (Filed 27th April, 1897.)

Claim.—An endoscopic instrument having a separate, or independent tube inclosing therein an incandescent electric lamp and detachably connected to the instrument by means of a slotted plate and set-screw, as shown and described, as and for the purposes set forth.

No. 56,136. Cultivator. (Cultivateur.)

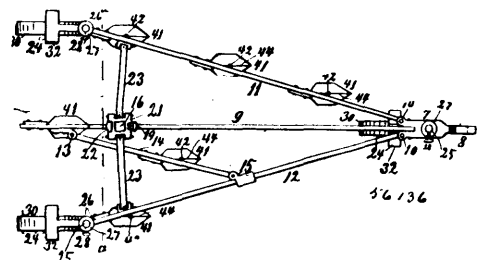

Frank Edwin Johnson, Minneapolis, Minnesota, U.S.A., 4th June, 1897; 6 years. (Filed 24th April, 1897.)

Claim.—1st. A cultivator having a frame consisting of a draw-head with a hitching hook at its front end, a central frame bar extending rearwardly therefrom, two side bars pivotally secured to and extending rearwardly from the drawhead, an oblique frame bar pivoted near the rear end of the central bar and having its front end pivoted to a block or guide sliding upon one of the slide bars, and teeth arranged upon all of said bars and means for spreading the side bars, substantially as shown and described. 2nd. The cultivator having a drawhead and a rigid central frame bar as 9, extending therefrom, the side frame bars 11 and 12, hinged thereto, with their front ends, the oblique bar 14, pivoted to the central bar and having its other end slidingly connected to one of the side bars and three cultivator teeth secured to one of the side bars and one to the rear end of the opposite side bar, one tooth to the central bar and one near the middle of the oblique frame bar, and means for spreading, closing, raising and lowering the frame, substantially as and for the purpose set forth.

No. 56,137. Alarm Device. (Cellule d'alarme.)

John F. Snapp, Frichton, Indiana, U.S.A., 5th June, 1897; 6 years. (Filed 26th April, 1897.)

Claim.—1st. An automatic fire alarm device, comprising the body, spring arms B, B' connected at one end to the body and having sockets at their free ends, a rigid bar of combustible material having its ends seated in the sockets of the spring arms so as to hold said arms apart, an inclosure carried by the arm B, and having an opening in one of its end walls, a contact C arranged in said inclosure and adapted to be electrically connected with a generator

and an electrical signal, a portion connected to the arm B¹ and extending through the opening in the wall of the inclosure, a con-

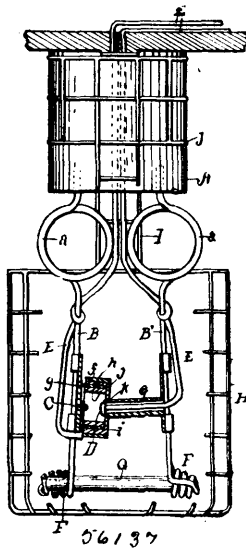

tact D carried by said portion of the arm B¹, and arranged in the inclosure and adapted to be electrically connected with the same generator and electrical signal as the contact C, and the wire cage connected with the body and surrounding the spring arms and their appurtenances, substantially as specified. 2nd. In an automatic fire alarm device, the combination of an inclosure comprising the wall *g* having a non-conducting lining, and a non-conducting cover having a central aperture, a contact arranged in said inclosure and adapted to be electrically connected with a generator and an electrical signal, a spring arm having a projecting portion extending through the aperture of the inclosure cover, a contact at the end of said projecting portion adapted to be electrically connected with a generator and a signal, and means for normally holding the contacts apart, substantially as specified. 3rd. In an automatic fire alarm device, the combination of an inclosure having an opening in one of its end walls, a contact C arranged in said inclosure and adapted to be electrically connected with a generator and an electrical signal, a piece *e* extending through and occupying the opening in the wall of the inclosure, a contact D carried by said piece *e* and adapted to be electrically connected with the same generator and electrical signal as the contact C, a combustible device adapted to normally hold the contacts apart, and means for moving said piece *e* inwardly when released so as to bring the con- C, D, together, substantially as and for the purpose set forth.

No. 56,138. Gas Generating and Utilizing Machine.
(*Fournaise à générer et utiliser le gaz.*)

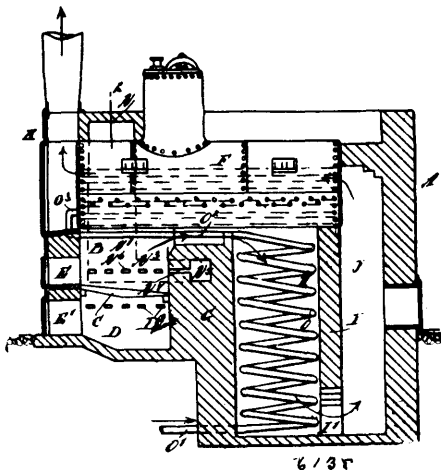

Seymour Green Smith, Plainfield, New Jersey, U.S.A., 5th June, 1897; 6 years. (Filed 28th April, 1897.)

Claim.—1st. A furnace, consisting of a casing having a fire-box in communication with a consuming chamber, the casing also having a condensing and gasifying chamber, comprising two legs straddling

the fire box and communicating at their lower ends with side chambers connected by a transverse channel, the chambers and channel having jets delivering into the fire box, a boiler located above the fire box and consuming chamber, a blower delivering into the condensing and gasifying chamber, and a steam pipe leading from the boiler to the blower, substantially as described. 2nd. A furnace, comprising a casing having a fire box, the furnace also having a condensing and gasifying chamber having two legs straddling the fire box, each leg communicating with a side chamber and the side chambers being connected by a transverse channel, the chambers and channel having jet openings delivering into the fire box, a boiler, a blower delivering into the condensing and gasifying chamber, and a steam pipe passing from the boiler to the nozzle of the blower, substantially as described. 3rd. A furnace, comprising a casing having a fire box, a consuming chamber divided from the fire box by a bridge wall, the casing also having a condensing and gasifying chamber leading to the fire box, and a chamber rearward of the consuming chamber with which the consuming chamber directly communicated, a boiler located above the consuming chamber and fire box and receiving the products of combustion from the chamber which communicates with the consuming chamber, a blower delivering into the condensing and gasifying chamber, and a steam pipe leading from the boiler to the nozzle of the blower, substantially as described. 4th. A furnace, comprising a casing having a fire box and a consuming chamber in communication with the fire box, the furnace also having an additional chamber rearward of the consuming chamber and directly communicating therewith, a boiler located above the fire box and consuming chamber and receiving the products of combustion from the chamber rearward of the consuming chamber, and a feed water pipe coiled within the consuming chamber, substantially as described. 5th. A furnace, comprising a casing having a fire box and a consuming chamber, the casing also having a condensing and gasifying chamber communicating with the fire box, a boiler located above the fire box and consuming chamber, a feed water pipe coiled within the consuming chamber, a blower delivering into the condensing and gasifying chamber, and a steam pipe leading from the boiler to the blower, substantially as described. 6th. A furnace, comprising a casing having a fire box and a consuming chamber divided by a bridge wall, the casing also having an additional chamber rearward of the consuming chamber, and a condensing and gasifying chamber above the fire box, the condensing and gasifying chamber having legs straddling the fire box, and the legs respectively communicating with side chambers connected by a transverse channel, the side chambers and passage having jet openings delivering into the fire box, a boiler located above the fire box and consuming chamber, and a blower delivering into the condensing and gasifying chamber, substantially as described.

No. 56,139. Spittoon. (Crachoir.)

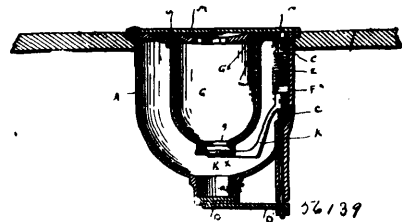

John P. Kane and Samuel Dinsmore, Dawson, Pennsylvania, U.S.A., 5th June, 1897; 6 years. (Filed 29th April, 1897.)

Claim.—1st. In a spittoon, the combination with a weather casing or box having a pivoted cover, a post mounted in a tubing communicating through an aperture with the interior of the casing, the upper end of the said post being square, a spring interposed between a collar on the post and a bracket on the inner wall of the casing of the spittoon or receptacle, having diametrically-disposed lugs on its outside adapted to register in recesses in the periphery of the opening of the casing, and a key for locking the receptacle to the casing or box, substantially as shown and described. 2nd. In a spittoon, the combination with the outer casing having an integral tubing opening therein, a vertically-movable spring-actuated post carried in said tubing, of the spittoon mounted within the casing, valve-plates carried on the post and designed to be seated under registering apertures in the bottoms of the spittoon and casing, and means for opening the valves by depressing the said post, and rotating the same, substantially as shown and described. 3rd. In combination with the spittoon having lugs on its inside wall, and held in the casing in the manner described, the cover having lateral recesses in its central aperture, and the key having lateral arms provided with recesses for engagement with the lugs on the inside of the spittoon, and lateral projections which are adapted to engage in the recesses in the central aperture of the cover, whereby the latter may be turned and locked, in the manner shown and described.

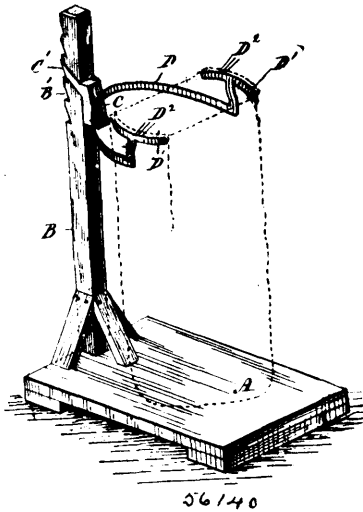
No. 56,140. Bag-holder. (Accroche-sac.)

William J. W. Kennedy, Menota, Manitoba, Canada, 5th June, 1897; 6 years. (Filed 3rd May, 1897.)

Claim.—A bag-holder, comprising a platform A, post B, provided with step notches B¹, a socket C, fitting on said post and engaging the notches, and spring-arms D, secured to the socket and having T-shaped ends provided with teeth D², as set forth.

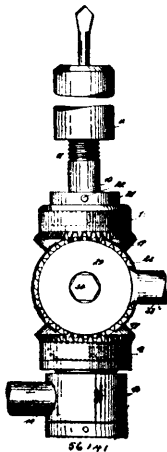
No. 56,141. Double Acting Ratchet Drills or Bits. (Foret à rochet ou mèche à double effet.)

Frank A. Reynolds and Stephen H. Manning, both of Lewiston, Maine, and Herschel C. Parker, Brooklyn, New York, all in the U.S.A., 5th June, 1897; 6 years. (Filed 4th May, 1897.)

Claim.—1st. A device of the character described, comprising a drill-shaft, ratchet wheels having teeth of similar pitch secured to the drill-shaft, gear wheels journaled on the drill-shaft, said gear wheels being recessed to fit over the ratchet wheels and provided with pawls to engage the ratchet wheels, a sleeve journaled on the drill-shaft between the gear wheels, said sleeve having recessed ends to receive and shield the teeth of the gear wheels, and a lever pinion journaled on the sleeve and engaging the two gear wheels, substantially as described. 2nd. A device of the character described, comprising a drill-shaft, a pair of ratchet wheels of similar pitch secured thereto, gear wheels journaled on the drill-shaft and provided with pawls to engage the ratchet wheels, a bearing sleeve journaled on the drill-shaft and having its ends recessed to receive and shield the gear of the gear wheels, and a lever pinion journaled on the sleeve and engaging the gear wheels, substantially as described.

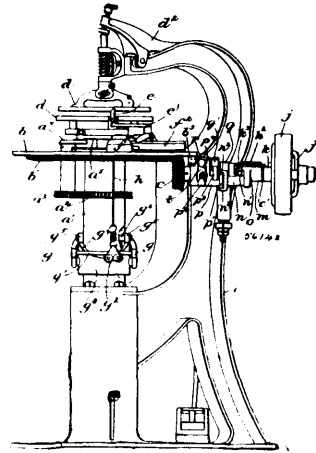
No. 56,142. Sole Rounding Machine.*(Machine pour arrondir les semelles.)*

The Flagg Manufacturing Co., assignee of Edward Erickson, both of Boston, Mass., U.S.A., 5th June, 1897; 6 years. (Filed 3rd May, 1897.)

Claim.—1st. A sole-rounding machine, comprising a rotary table, a movable carrier mounted thereon, a knife-holder adapted to move back and forth on said carrier, a flexible pressure-transmitting cord or chain connected with the knife-holder, and a guiding pulley for said cord having provisions for permitting lateral movements of the portion of the cord that passes over said pulley. 2nd. A sole-rounding machine, comprising a rotary table, a movable carrier mounted thereon, a knife-holder adapted to move back and forth on said carrier, a flexible pressure-transmitting cord or chain connected with the knife-holder, and a guiding pulley for said cord having end flanges separated by a cylindrical body which is considerably longer than the thickness of the cord, whereby the cord is enabled to slip laterally between said flanges. 3rd. In a sole-rounding machine, the combination with a rotary table carrying a knife-holder and provided with gear-teeth, of a shaft, a pinion on said shaft meshing with said gear-teeth, a clutch-pulley loosely mounted on said shaft, members on said shaft adapted by their partial rotation to move said pulley longitudinally into engagement with the shaft, and mechanism for automatically turning said members in a clutch releasing-direction, consisting of a sleeve mounted on an auxiliary shaft and having gear-teeth which mesh with corresponding gear-teeth in one of the before-mentioned members, a collar mounted on said auxiliary shaft and adapted to turn said sleeve, a stop member on said collar, and a complementary stop-member on the rotary table adapted to engage the first-mentioned stop-member and thereby rotate the said collar and sleeve. 4th. In a sole-rounding machine, the combination with a rotary table carrying a knife-holder and provided with gear-teeth, of a shaft, a pinion on said shaft meshing with said gear-teeth, a clutch-pulley loosely mounted on said shaft and adapted to be moved longitudinally into or out of engagement with a complementary clutch member affixed to the shaft, a clutch-operating mechanism, including a collar mounted on an auxiliary shaft and having an arm or handle, and connecting devices between said collar and the clutch-pulley whereby opposite movements of the collar are caused to connect and disconnect the clutch-pulley and the clutch member on the shaft, a shaft-arresting mechanism connected with the collar and operated thereby, a sliding bolt carried by said collar and adapted to act as a stop-member, a stop-member on the rotary table adapted to engage the bolt and thereby turn the collar in its clutch-disengaging direction, and means for disengaging said stop-members, the said means consisting of a lever pivoted to the before-mentioned arm or handle, and a sliding plate connected with said lever and having a diagonal slot engaging a stud on the sliding bolt, the said plate being moved by the lever in a direction transverse to the said bolt, so as to retract the same.

No. 56,143. Stump Puller. (Arrache-souche.)

Benoite Corriveau, d'Israëli, Québec, Canada, 5 juin 1897; 6 ans. (Déposé le 22 avril 1897.)

Résumé.—Un appareil pour arracher les souches comprenant deux forts crochets B disposés en V, une roue supportant l'avant de l'ap-

pareil, une maille à laquelle on attèle les chevaux, etc., et des mancherons servant à ajuster convenablement la machine sur les souches

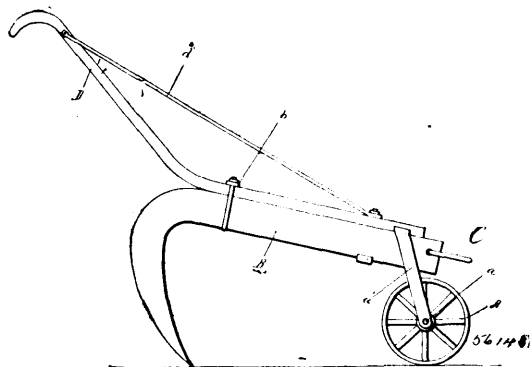

que l'opérateur désire arracher, le tout tel que décrit dans la spécification précédente et pour les fins indiquées.

No. 56,144. Flooring. (Parquetage.)

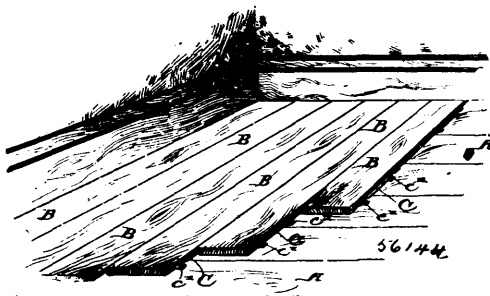

John White Heaton, Caroline A. Heaton, Samuel Stephens, all of Indianapolis, and Alexander Craigmile Ayres, Woodruff Place, all in Indiana, U.S.A., 5th June, 1897; 6 years. (Filed 5th May, 1897.)

Claim.—1st. The combination, in an upper or parquetry floor or surfacing, of the flooring strips B having grooves in their edges, and the thin metal strips C having tongues cut from their edges and bent downward at right angles with the plane of said strips and thence outwardly parallel therewith and adapted to be secured to the under floor upon which said upper floor is laid and thus secure said upper floor thereto, the whole being constructed and arranged substantially as shown and described. 2nd. A fastening for parquetry floors and such like structures, consisting of a straight flat strip of sheet metal having projections or ears thereon, said projections or ears being formed by cutting into the strip of metal from the side, and bending the portion so cut downwardly at right angles to the plane of the strip, and thence outwardly in a plane substantially parallel with the strip, substantially as shown and described and for the purpose specified.

No. 56,145. Hoodwink. (Bandeau.)

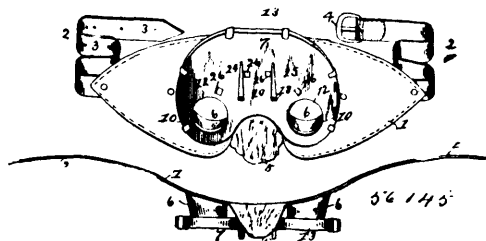

Edmund De Moulin and Ulysses S. De Moulin, both of Greenville, Illinois, U.S.A., 5th June, 1897; 6 years. (Filed 1st May, 1897.)

Claim.—1st. In a hoodwink, the combination with a suitable face-pad provided with projecting eye-pieces, of a casing attached to and connecting the outer ends of the eye-pieces and having openings to correspond therewith, a suitable shutter mechanism provided with double shutters adapted to close the openings of the casing and to be operated alternately to distort the vision through the eye-pieces, said shutter mechanism being entirely inclosed within the said casing, whereby compactness is secured and liability to injury obviated, and means for operating the shutter mechanism from the exterior of the casing, substantially as described. 2nd. In a hoodwink, the combination with a face-pad provided with projecting eye-pieces,

of a casing attached to and connecting the outer ends of the eye-pieces, and provided with openings corresponding therewith, a shutter mechanism arranged within the casing, disposed at right angles to the line of vision and moving simultaneously in opposite directions, and means for operating the shutter mechanism from the exterior of the casing, substantially as described. 3rd. In a hoodwink, the combination with a face-pad provided with projecting eye-pieces, of a casing mounted on and connecting the outer ends of the eye-pieces and provided with corresponding openings, a pair of shafts journaled on the casing and disposed longitudinally of the eye-pieces, and provided with exteriorly-arranged handles, and a shutter mechanism comprising two pairs of shutters disposed at right angles to the line of vision and mounted on the said shafts and connected together to move simultaneously in opposite directions, one pair of shutters having one of its members fixed to one shaft and loose on the other, and the other pair being reversely arranged so that each shaft has one fixed shutter and one loose shutter, whereby the shutters are independently geared and are capable of independent operation, substantially as and for the purpose described. 4th. In a hoodwink, the combination with the face-pad, provided with fastening means, and having the projecting eye-pieces fastened thereto, of an inclosing casing attached to said projecting eye-pieces and containing a shutter mechanism, said shutter mechanism consisting of a pair of opaque screens, one of which is fast on a shaft and the other of which is loose on a shaft, said screens being provided with intermeshing gears, a pair of coloured transparent screens mounted on the aforesaid shafts, one of said latter screens fixed to one of the shafts and the other loose on its shaft, said screens provided with intermeshing gears and a flanged separating-plate adjusted between said pairs of screens, handles external to said casing and applied respectively to the projecting ends of said shafts, and stops therefor, whereby through the operation of said handles the light through said eye-pieces is interrupted or distorted, substantially as set forth.

No. 56,146. Table. (Table.)

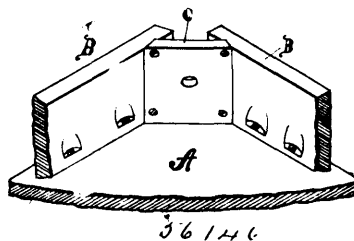

Summer E. Paine, Orwell, Ohio, U.S.A., 5th June, 1897; 6 years. (Filed 1st May, 1897.)

Claim.—1st. The combination with a table-top having the side pieces or rails secured thereto, with their ends separated and having projections below their upper edges and forming a seat for the leg, the corner-piece bridging the space between the side rails, of the leg having the solid top portion and recesses below said portion on its inner ends, for the reception of the projections on the side rails, and a fastening device passing through the corner-piece and into the leg for holding the same to its seat, substantially as described. 2nd. In a table, such as described, the combination with the top, the side pieces or rails secured thereto and having their ends below their upper edges cut diagonal to form projections E and the corner-piece bridging the space between the side pieces or rails within the corner, of the leg having the squared upper end with recesses corresponding to the projections E formed thereon by cutting away the inner side of said leg at an obtuse angle and a fastening device passing through the corner-piece and into the leg for holding the parts in adjusted position, substantially as described.

No. 56,147. Door Hanger Track. (Ferrure de porte.)

George C. Gardner, Chicago, Illinois, U.S.A., 5th June, 1897; 6 years. (Filed 3rd May, 1897.)

Claim.—1st. In a device of the class described, the combination with a roller having suitable bearing faces, of an elastic casing formed with the cup portions a', anti-friction balls C, interposed between said cups and bearing faces, and a screw connecting said cups and adapted to draw them toward each other, substantially as described. 2nd. In a device of the class described, the combination with a roller composed of a web portion having a suitable periphery and separate bearing cones secured to said web portion, of an elastic casing having the recessed cup portions a', anti-friction balls C, interposed between said bearing cones and cups, and a screw connecting said cups and adapted to draw them toward each other, substantially as described. 3rd. In a device of the class described, the combination with a grooved roller having suitable bearing faces, of an elastic casing comprising two shells formed with the annular recessed portions a', adapted to serve as bearing cups, anti-friction balls interposed between the bearing faces on the roller and said cups, and a screw connecting the cups whereby they may be drawn toward each other to take up the wear, substantially as described. 4th. In a device of the class described, the combination with a roller

formed of two web portions *c*, flanged at their peripheries and having the overhanging flanges *b*² and the bearing cones *b*⁴ having the

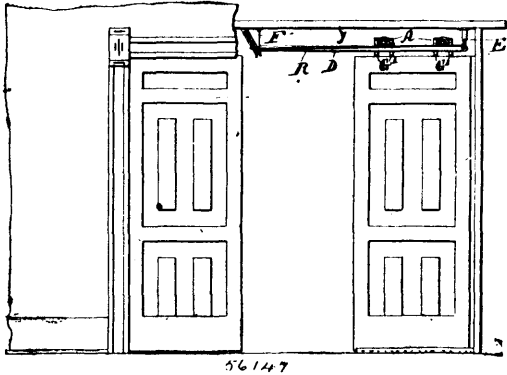

flanges *b*³, held between the overhanging flanges *b*², of a casing formed with suitable bearing cups, and anti-friction balls *C*, interposed between the bearing cones and cups, substantially as described. 5th. The combination with suitably supported ball cups, of a roller or pulley composed of two annular sheet metal pieces secured together having their outer and inner edges offset in opposite directions to form grooves around the outer and inner margins and two inner circular pieces, the combined outer edges of which just fill said inner groove and are firmly held therein and whose inner portions are offset in opposite directions to form suitable bearing surfaces for the balls opposed to the said cups whereby the main portion of the roller and portions upon which the balls are to run may be made of such material as best adapted thereto, substantially as described. 6th. The combination with a track loosely supported at one end and connected with a link *c*, at the opposite end, said link being pivoted to a suitable support, of the rod *R*, connected to said link and extending toward the free end of the track, and a suitably guided block *F*², connected with the rod *R*, and means for moving the block toward or away from the pivoted end of the track whereby said end of the track may be lowered or raised, substantially as described. 7th. The combination with the track connected at one end with a link *c*¹, pivoted to a suitable support, of the standard *F*, adapted to receive the free end of the track and having the inclined guideway *F*¹, and the slide block *F*², sliding in said guideway, and a rod connecting said block with the link *c*², and the set screw *f*³, adapted to move said slide block in said guideway and thereby raise the pivoted end of the track, substantially as described.

No. 56,148. Dust Screen for Windows.

(Store de fenêtre.)

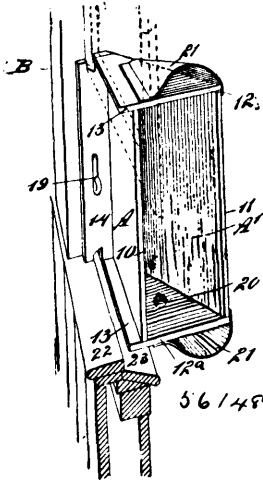

Hugh Brooks Shutts, Shawneetown, Illinois, U.S.A., 5th June, 1897; 6 years. (Filed 1st May, 1897.)

Claim.—1st. The dust screen having an open box body constructed to fit a window frame, and a rotatable handle with a catch or eccentric to engage the window frame, substantially as described. 2nd. A dust screen for car windows, consisting of a box-body having its outer side inclined outwardly from the front edge of the body, the ends of the body being provided with escape-openings, and hoods located over the escape-openings, being secured to the outer faces of the ends of the box-body, the said hoods being open at their rear ends and otherwise closed, the box-body being likewise

open at its rear end, as and for the purpose set forth. 3rd. A dust screen for car windows, consisting of a box-body angular in cross-section, its rear or expanded portion being open and the ends of the body provided with escape openings, and hoods located over the outside of the openings, which hoods are contracted at their forward ends and open at their rear or expanded ends, and a fastening device for attaching the screen to a car, substantially as described. 4th. A dust screen for car windows, consisting of a box-body angular in cross-section and provided at the top and at the bottom with escape-openings, and hoods shaped correspondingly to the box-body and secured to the outer faces of the ends of the box over the escape-openings, the box being open at its wider portion and closed at its contracted portion, and the hoods having corresponding portions also closed and open, and means, substantially as described, for attaching the screen at either side of a window frame, as and for the purpose set forth. 5th. A dust screen for car windows, consisting of a box-body, angular in cross-section and provided at the top and at the bottom with escape-openings, and hoods shaped correspondingly to the box-body and secured to the outer faces of the ends of the box over the escape openings, the box being open at its wider portion and closed at its contracted portion, and the hoods having corresponding portions also closed and open, an upright secured to the inner front portions of the box-body, the said upright being provided with a rib upon its forward face adapted to enter a sash-groove in a window frame, and the ends of the upright being recessed to receive the bottom rail of a window-sash, as and for the purpose specified.

No. 56,149. Strap for Boots and Shoes.

(Courroie pour chaussures.)

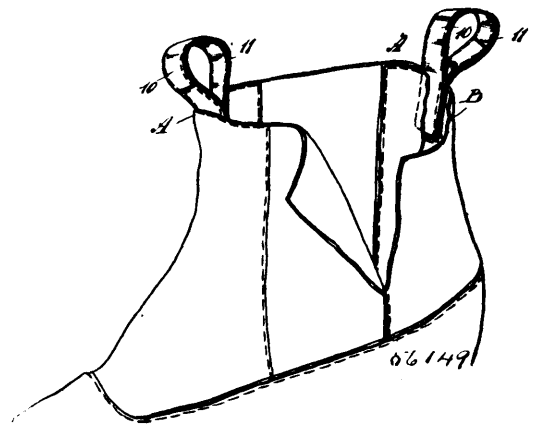

George E. Shoop, Golconda, Illinois, U.S.A., 5th June, 1897; 6 years. (Filed 1st May, 1897.)

Claim.—1st. A strap for boots and shoes, comprising a body consisting of strips of a pliable material, laid one upon the other and secured together at their side edges, and a strip of rubber located between the strips of the pliable material between the fastening at the edges of the said body material, as and for the purpose set forth. 2nd. A boot strap, having two strips of flexible material laid one upon the other and secured together at the side edges, and a flat spring enclosed between the strips, substantially as described.

No. 56,150. Machine for Soaking and Sterilizing Bottles. (Machine pour tremper et stériliser les bouteilles.)

Emil Kersten, Richmond, Virginia, U.S.A., 5th June, 1897; 6 years. (Filed 1st May, 1897.)

Claim.—1st. A machine for sterilizing and soaking bottles, comprising a tank adapted to receive a cleaning liquid, a wheel mounted to revolve and arranged to pass with its lower portion through said liquid, and provided with transverse inclined openings extending entirely therethrough, and pipes open throughout their lengths and inserted in said openings and arranged to receive and hold the bottles to be cleansed in an inclined position relative to the face of said wheel, substantially as set forth. 2nd. A machine for sterilizing and soaking bottles, comprising a tank adapted to receive a cleansing liquid, a wheel mounted to revolve and adapted to pass with its lower portion through said liquid, supports secured to said wheel and inclined in the direction in which said wheel is designed to revolve, said supports being inserted in the necks of the bottles to be cleansed and holding said bottles in the inclined position relative to the face of said wheel, and a guide board held on said tank and adapted to be engaged by the bottom of the bottles as the latter move down into said liquid, as and for the purpose set forth. 3rd. A machine for sterilizing and soaking bottles, comprising a tank adapted to receive a cleansing liquid, a wheel mounted to revolve and adapted to pass with its lower portion through said liquid, hollow pipes open at both ends and having one end inserted in

openings extending entirely through said wheel, said pipes being inclined in the direction in which said wheel is designed to revolve

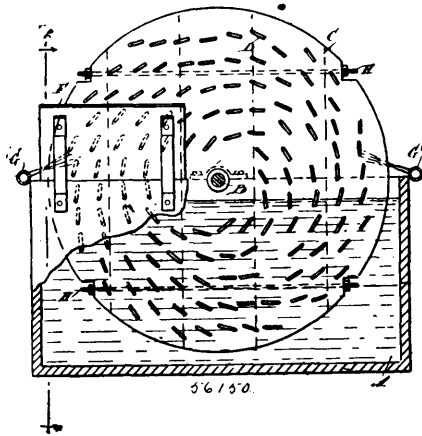

and inserted in the necks of the bottles to be cleaned, whereby said bottles are held in an inclined position relative to the face of said wheel, and a guide board held on said tank and adapted to be engaged by the bottoms of the bottles as the latter are moved down into said liquid, as and for the purpose set forth. 4th. In a machine for soaking bottles, the rotatable disc consisting of segmental sections or strips bolted together and carrying bottle supports, substantially as described. 5th. In a machine for soaking bottles and the like, the rotatable disc or wheel carrying bottle supports, in combination with one or more spraying devices, substantially as described.

No. 56,151. Steam Boiler. (Chaudières à vapeur.)

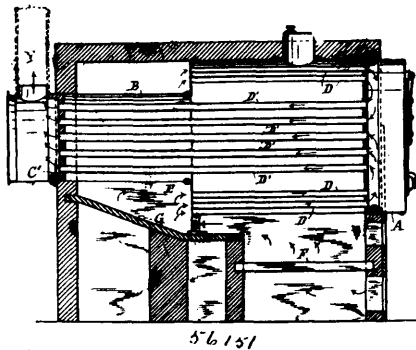

James Ross Vance, Geneva, New York, U.S.A., 5th June, 1897; 6 years. (Filed 3rd May, 1897.)

Claim.—1st. In a steam boiler, the combination of a horizontal cylinder, a smaller horizontal cylinder concentric with and projecting from one end of the first cylinder, fire tubes extending through each cylinder, a chamber at one end of the large cylinder communicating with all the tubes, one end of each of the tubes in the larger cylinder opening into the furnace, and a chamber at the end of the smaller cylinder communicating with its tubes and the chimney, substantially as described and shown. 2nd. In a steam boiler, the combination of a horizontal cylinder, a smaller horizontal cylinder concentric with the first cylinder and projecting from one end of the latter, said cylinders being of substantially the same length, the larger cylinder having substantially twice the diameter of the smaller cylinder, fire tubes extending through each cylinder, a chamber at one end of the large cylinder communicating with all the tubes, one end of each of the tubes in the larger cylinder opening into the furnace, and a chamber at the end of the smaller cylinder communicating with its tubes and the chimney, substantially as shown and described. 3rd. In a steam boiler, the combination of a horizontal cylinder, a smaller horizontal cylinder joined to one end of the larger cylinder and concentric therewith, partitions C and C', fire tubes extending through the cylinders and supported by the partitions, short fire tubes extending through the large cylinder and supported by one of the partitions and the end of the cylinder, a furnace enclosing the boiler having the grate below the large cylinder, and a flue leading back beneath the small cylinder having an inclined surface, substantially as and for the purpose specified.

No. 56,152. Meat Chopping Machine. (Pilon à viande, etc.)

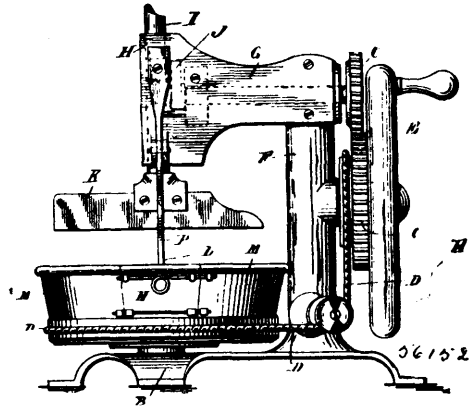

Ellen Graddon, Regent's Park, London, England, 5th June, 1897; 6 years. (Filed 4th May, 1897.)

Claim.—The particular construction and arrangement of the several parts of the chopping machine as shown on the annexed drawings and the operation of the movable parts as set forth.

No. 56,153. Post Hole Augers. (Tarière.)

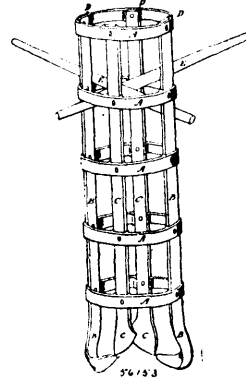

John Richmond Morris, Huron, Ontario, Canada, 5th June, 1897; 6 years. (Filed 5th May, 1897.)

Claim.—1st. The combination of the diggers B, B, and the lifters C, C, substantially as and for the purposes hereinbefore set forth. 2nd. The combination with the diggers E, E, and the lifters C, C, of the open top, substantially as and for the purposes hereinbefore set forth.

No. 56,154. Singletrees and Hook Therefor. (Crochet de palonniers.)

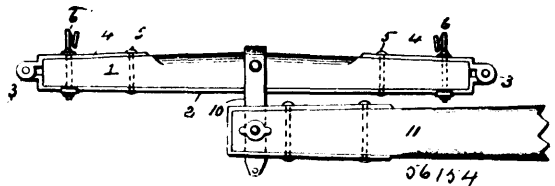

Allen J. Clark, Jackson, Tennessee, U.S.A., 7th June, 1897; 6 years. (Filed 3rd May, 1897.)

Claim.—1st. In a single or double tree a metallic strip passing behind the tree, a hinge joint fashioned at the end of the rear strip and at the end of the tree, a second strip hinged to the rear strip at said hinge joint, the last said strip passing in front of the tree, said strips being adapted to be secured to the tree on opposite edges. 2nd. In a single or double tree a metallic strip passing behind the tree and around the end of the same, a curved tongue located at the extreme end of said strip and forming a member of a hinged joint, a second strip having a suitable perforation, the curved tongue of the first strip adapted to enter said perforation and thus secure the two strips together, the last strip being adapted to pass in front of the tree, said strips adapted to be secured to opposite edges of the tree. 3rd. In combination with the tree a hook adapted to engage a chain or trace, said hook having on its shank a squared section, a plate having a squared perforation located at the forward edge of the tree, the inner surface of the plate being concaved and conform-

ing to the surface of the forward edge of the tree, said plate being thereby held in permanent position, the shank of the hook passing through the perforation in the plate and through a perforation in the tree, a second plate located at the rear edge of the tree and a nut engaging the thread at the rear end of the hook shank and adapted to take up the shrinkage in the tree.

No. 56,155. Steam Boiler Furnace.

(Fornaise de chaudière à vapeur.)

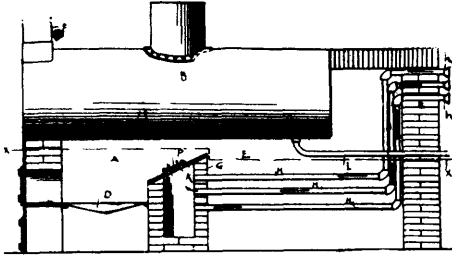

John Price, Trenton, New Jersey, U.S.A., 7th June, 1897; 6 years. (Filed 1st May, 1897.)

Claim.—In a steam-boiler furnace, the combination with the fire-bridge having an interior chamber, and an upwardly and rearwardly inclined upper wall provided with an air-discharge opening or openings, and means for controlling such opening or openings, of a plurality of air conducting flues, whose forward ends open into said chamber, said flues having horizontal portions which extend rearwardly through the lower portion of the combustion chamber, thence vertically through the rear portion of said chamber, thence horizontally out through the rear wall of said chamber, opposite the rear end of boiler, and terminate in enlarged open ends, said flues being arranged in superpose series extending substantially the width of the combustion-chamber, and separated from each other both individually and serially.

No. 56,156. Roof Gutter. (Gouttière pour toitures.)

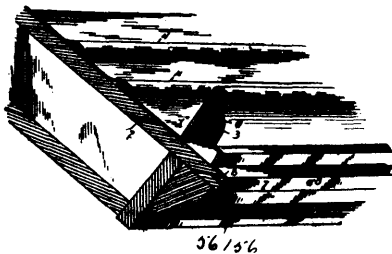

James R. Bryant, Crawfordsville, Indiana, U.S.A., 7th June, 1897; 6 years. (Filed 1st May, 1897.)

Claim.—A sheet metal gutter comprising an apron portion, and a flange arranged perpendicularly at the foot of the apron, the said apron being provided with S-shaped crimps constituting flat rests for the shingles or other roofing material, and also establishing an air-passage as described, in combination with a separately formed moulding or cornice of sheet metal interposed between the flange of the gutter and the edge of the roof, the contiguous edges of the gutter-flange, and the moulding or cornice being reversely bent to form hooked lips which are brought together in interlocking engagement, whereby the application of the gutter to the roof is facilitated and the strength of the gutter increases, substantially as described.

No. 56,157. Fabric Brushing Machine.

(Machine à brosser les étoffes.)

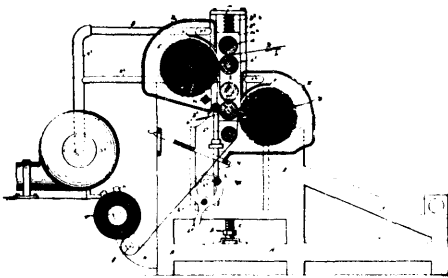

Frederick A. H. Dewald and Edward Cripell, both of Catskill, New York, U.S.A., 7th June, 1897; 6 years. (Filed 1st May, 1897.)

Claim.—1st. In a machine of the class herein specified, said machine being provided with brush rollers E and F, and with two sets

of feed rollers as *a* and *a'* and *b* and *b'*, one set of which is placed above the other, the combination with lower set of feed rollers, of a vertically adjustable guide roller, which is mounted in front thereof, substantially as shown and described. 2nd. In a machine of the class herein specified, said machine being provided with brush rollers E and F, and with two sets of feed rollers as *a* and *a'* and *b* and *b'*, one set of which is placed above the other, the combination with the lower set of feed rollers of a vertically adjustable guide roller, which is mounted in front thereof, said feed roller, and said guide roller being mounted in a vertically adjustable frame, and said guide roller being mounted on supports which are vertically adjustable on said vertically adjustable frame, substantially as shown and described. 3rd. In a machine for brushing knit goods, woollen goods, and other fabric, said machine being provided with brush rollers, the combination with said rollers of casings, by which the same are inclosed, said casings being provided with pipes, which are in communication therewith, and which are also in communication with blower substantially as shown and described. 4th. The combination with the brush rollers of a fabric brushing machine, of casings by which said rollers are inclosed, said rollers being provided with pipes which are in communication therewith, and with a blower substantially as shown and described.

No. 56,158. Axle Box. (Boîte à graisse.)

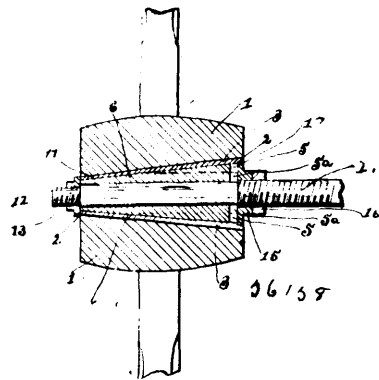

William James McLean, Gloster, Mississippi, U.S.A., 7th June, 1897; 6 years. (Filed 1st May, 1897.)

Claim.—1st. The combination with an axle-spindle having its outer end screw-threaded and provided with a nut, and its inner end enlarged and screw-threaded, a flange-nut and a lock-nut upon the latter end, the axle-skein having V-shaped tongues, and an axle-box having V-shaped grooves engaged by said tongue, a shoulder and flange upon the inner end of the axle-box engaged by said flanged nut to adjust the box and skein upon the axle-spindle, substantially as shown and described. 2nd. The combination with a straight axle-spindle having screw-threads upon each end, and a nut upon its outer end, and a flange-nut upon its inner end, and a lock-nut upon the same end, an axle-box having V-shaped tapering grooves extending through its length, an interior shoulder surrounded by a flange having said grooves continued therein, an axle-skein having tongues to engage said grooves and adjustably held against the outer end by said flanged nut housed by the flange of the axle-box, substantially as shown and described.

No. 56,159. Roadway Gate. (Barrière.)

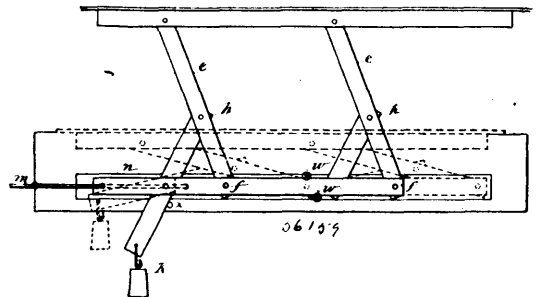

Fred Hammond Nichols, Lynn, Mass., U.S.A., 7th June, 1897; 6 years. (Filed 1st May, 1897.)

Claim.—A roadway gate apparatus comprising a chamber, a fixed bar *n* therein, bars *h* pivoted at their lower ends upon said fixed bar, bars *c*, pivoted upon the free ends of the bars *h*, a bar *a* pivoted upon the upper ends of the bars *c*, a bar *f* pivoted to the lower ends of the bars *c*, guides, as *v*, between which the bar *f* slides, and means for moving said bar *f*, to operate the gate, substantially as described.

No. 56,160. Scraper and Grader.
(*Grattoir et machine à régalege pour chemins.*)

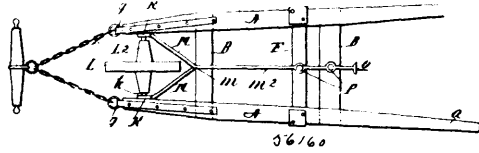

Stephen Dombrowsky, Oyster Bay, New York, U.S.A., 7th June, 1897; 6 years. (Filed 1st May, 1897.)

Claim.—1st. The herein described scraper and grader which consists of a frame, the forward end of which is provided with a wheel which is supported between vertical bars which are pivotally connected with the frame, and the upper ends of which are connected with a yoke which extends backwardly, and which is provided with a rod by which the wheel may be raised or lowered, and said frame being also provided at or near its rear end with a plate or blade which is suspended therefrom, and crosswise thereof, and which is held at an inclination thereto, substantially as shown and described. 2nd. The herein described scraper and grader which consists of a frame which comprises two side bars, a wheel suspended between the forward ends thereof, by means of a frame pivotally connected therewith, said side bars being provided with handles at their rear ends, and said frame by which the wheel is suspended, being provided with a rod by which the wheel may be raised or lowered, and said frame being also provided near its rear end with legs, or supports, and with a plate or blade which is suspended therefrom, and transversely thereof, and which is adapted to serve as a scraper, substantially as shown and described. 3rd. The herein described scraper or grader, which comprises the side bars as A, which are provided with handles at their ends, a wheel pivotally supported between the forward ends of said side bars by means of vertical bars which are pivotally connected therewith, a yoke by which the upwardly ends of said vertical bars are connected, a rod connected with said yoke, and extending backwardly, and provided with means for operating the same, to raise or lower the wheel, said frame being also provided near its rear end with a plate or blade which is suspended therefrom, and transversely thereof, and which is held at an inclination thereto, substantially as shown and described.

No. 56,161. Pipe Coupling. (*Joint de tuyaux.*)

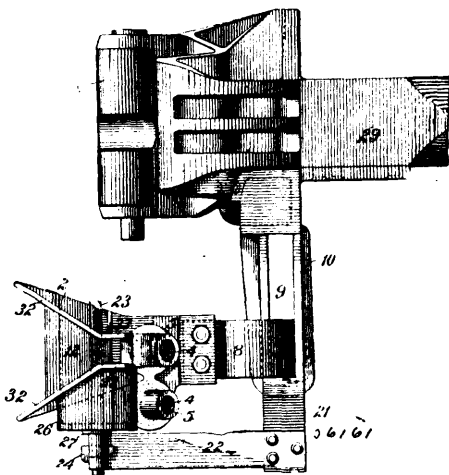

Nicholas F. Niederlander, St. Louis, Missouri, U.S.A., 7th June, 1897; 6 years. (Filed 30th April, 1897.)

Claim.—1st. In an automatic pipe coupling, the combination with two half sections, which are adapted to be coupled together by a longitudinal movement when the half sections are engaged, and by a lateral movement relative to one another at the end of the longitudinal movement, of means for holding the half sections laterally apart during the longitudinal movement until the openings through the half sections are in position to register by a lateral movement, and non-riding abutting surfaces which are engaged when the half sections are coupled for preventing relative movement of the half sections beyond the coupling position, substantially as set forth. 2nd. In a pipe coupling, the combination with two half sections, which are adapted to be coupled together by a longitudinal movement and a lateral movement relative to one another at the end of the longitudinal movement, of means for holding the half sections laterally apart until the longitudinal movement is completed, and non-riding abutting surfaces which are adapted to be engaged when the half sections are coupled for locking the half sections together

to prevent longitudinal movement of the half sections, relative to one another, beyond the coupling position, substantially as set forth. 3rd. In a pipe coupling, the combination with two half sections, which are adapted to be coupled together by a longitudinal movement and a lateral movement relative to one another at the end of the longitudinal movement, of means for holding the half sections laterally apart in the act of coupling, and means for locking the half sections together when in the coupled position to prevent lateral movement of the half sections, substantially as set forth. 4th. In a pipe coupling, the combination with two half sections, which are adapted to be coupled together by a longitudinal and a lateral movement relative to one another, of a tongue and groove on the face of each half section, which is adapted to engage with a similar tongue and groove on the other half section, the tongues and grooves being so formed as to overlap one another and lock the two half sections together as they approach one another by a lateral movement and to prevent relative movement of the half sections beyond the coupling position, substantially as set forth. 5th. In an automatic pipe coupling, the combination with two half sections, which are adapted to be coupled together, of a tongue formed on the face of each half section, which is adapted to engage with a groove on the other half section, the tongues and grooves being so formed that their sides overlap when the sections are brought together into the coupled position by a longitudinal and lateral movement only, and thereby lock the two half sections together so as to prevent lateral movement apart of the half sections, substantially as set forth. 6th. In a pipe coupling, the combination with two half sections, which are adapted to be coupled together by a longitudinal and lateral movement relative to one another, of a tongue on each half section which is adapted to bear on the face of the other half section for holding the two half sections laterally apart until the longitudinal movement is completed, and a groove formed in each half section into which the tongue on the other half section is adapted to fit, the tongues and grooves being formed with overlapping portions so as to interlock with one another by a longitudinal and lateral movement and prevent lateral or longitudinal movement of the half sections relative to one another, except when they are moved longitudinally in the proper direction for uncoupling, substantially as set forth. 7th. In an automatic pipe coupling, the combination with a half section or shoe, of a hanger or support, a spring secured to the hanger and forming a support for the half section or shoe, and a rod or pin on the outer end of the spring, which passes through the hanger or shoe and forms a guide therefor, substantially as set forth. 8th. In an automatic pipe coupling, the combination with a half section or shoe, of a spring secured to the shoe and adapted to engage with a similar half section or shoe, a hanger or support, an opening in the hanger through which the spring on the shoe passes, and a spring secured at one end to the hanger and at its other end loosely connected to the half section or shoe, substantially as set forth. 9th. In an automatic pipe coupling, the combination with a half section or shoe, of a hanger or support, a spring secured to the hanger, which is adapted to support and to offer an elastic yielding resistance to lateral movement of the half section or shoe, and a guide rod or pin secured to the spring and passing through an opening in the half section or shoe, the opening through the shoe being so formed as to permit longitudinal or angular movement of the shoe relative to the spring and guide, substantially as set forth. 10th. In an automatic pipe coupling device, the combination with a half section of the coupling device, of a vertical elastic hanger with which the half section is loosely connected in such a manner as to permit a free vertical and longitudinal movement of the connecting portion of the half section relative to the hanger within certain limits, and which is adapted to yield longitudinally when acted on by a movement of the half section beyond the limit of the free movement, substantially as set forth. 11th. In an automatic pipe coupling device, the combination with a half section of the coupling device, of a spring attached to the half section, and a vertical elastic hanger, to which the half section is loosely connected by means of the spring, and which is adapted to yield when acted on by a longitudinal movement of the half section, substantially as set forth. 12th. In an automatic pipe coupling device, the combination with a half section or shoe, of a spring secured to the shoe and adapted to engage with a similar half section or shoe, a vertical elastic hanger, and an opening in the hanger through which the spring passes, the hanger being adapted to yield and offer an elastic resistance to inward movement of the shoe and spring, substantially as set forth. 13th. In an automatic pipe coupling device, the combination with a half section or shoe, of a vertical elastic or spring hanger, a spring secured to the shoe and passing through an opening in the hanger, and a spring secured to the hanger and provided with a guide rod or pin, which is loosely connected with the shoe, substantially as set forth.

No. 56,162. End Gate for Wagons.
(*Arrière panneau de tombereaux.*)

Columbus M. Davis, Waggoner, Illinois, U.S.A., 7th June, 1897; 6 years. (Filed 1st May, 1897.)

Claim.—1st. In a device of the class described, the combination with an end gate or door, of a horizontal locking bar provided at its outer end with a hook, a substantially vertically-disposed operating lever fulcrumed at its lower end and connected between its ends with the locking bar, a substantially L-shaped keeper having a horizontal

portion receiving the operating lever, and a link arranged on the upwardly extending portion of the keeper and engaging over the

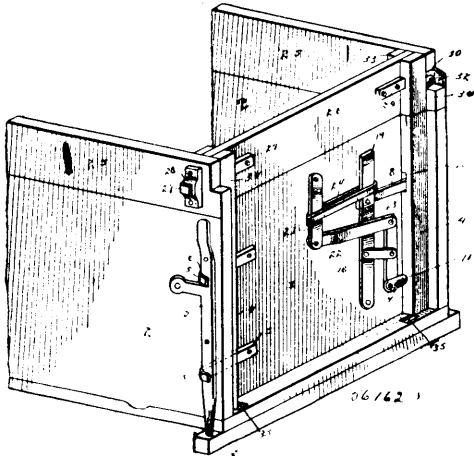

outwardly and downwardly to form a wing floor and a portion adapted to swing outwardly and in a direction at right angles to the

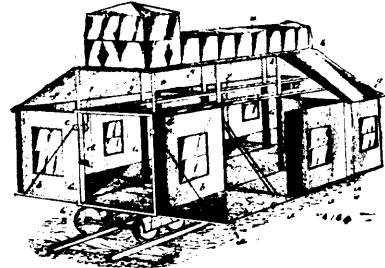

upper portion of the operating lever, substantially as described. 2nd. In a device of the class described, the combination with an end gate or door provided at its side with rigid hooks, upper and lower rods provided at its side with rigid hooks, upper and lower rods disposed horizontally and arranged to slide on the end gate or door, one of the rods being provided with a hook, of an operating lever disposed substantially vertically, fulcrumed at its lower end and connected between its ends with the upper rod, the lever 17, fulcrumed at its upper end and pivoted at its lower end to the lower rod, a link pivoted to the operating lever and similarly connected to the lever 17, at a point between the ends thereof, and means for holding the operating lever against movement when the parts are locked, substantially as described. 3rd. In a device of the class described, the combination of an end gate or door provided on one side with rigid hooks, a substantially L-shaped keeper mounted on the end gate or door and having one portion disposed at a slight inclination, upper and lower locking rods or bars being provided with a hook, an operating lever disposed vertically in the horizontal portion of the keeper, fulcrumed at its lower end and pivoted between its ends to the upper rod or bar, a link arranged on the upper portion of the keeper and engaging the handle portion of the operating lever, and a lever 17, fulcrumed at its upper end, pivoted at its lower end to the lower rod or bar and connected between its end with the operating lever, substantially as described. 4th. In a device of the class described, the combination of a wagon body provided at one side with horizontal openings and having upper and lower openings 12 and 13 at its outer side, an end gate having at one side a cleat 4, provided with upper and lower openings, rigid hook mounted on the opposite side of the end gate and extending through the horizontal openings of the wagon body, a lower rod or bar guided in the lower opening of the cleat 4, and engaging the opening 13 of the wagon body, an upper rod arranged in the upper opening of the cleat and provided at its outer end with a hook, said rod passing through the upper opening 10 of the wagon body, an operating lever connected with the upper rod, a lever 17 fulcrumed at its upper end and connected at its lower end to the lower rod or bar, a link connecting the lever, means for holding the operating lever when the parts are locked, and reinforcing bars secured to the outer faces of the sides of the wagon body engaged by the rigid hook and provided with horizontal arms, substantially as and for the purpose described.

No. 56,163. Hammock-spreader. (Etendeur de hamacs.)

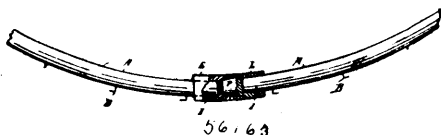

William H. Shetterly, Kalamazoo, Michigan, U.S.A., 7th June, 1897; 6 years. (Filed 1st May, 1897.)

Claim—In a hammock-spreader, the metal coupling composed of two metal parts, each part cored on its outer end to receive the hammock-sticks, one of said metal parts having its inner end tapered, and the other part having a funnel-shaped core in its inner end to receive the inner end of the other part, and both parts being attached rigidly to their respective hammock-sticks, substantially as set forth.

No. 56,164. Railway Car, etc. (Chars de chemin de fer, etc.)

Albert Bierstadt, New York, State of New York, U.S.A., 7th June, 1897; 6 years. (Filed 11th May, 1897.)

Claim.—1st. A railway car or other like vehicle provided with a side wall or walls composed in part of a portion adapted to swing

said floor, substantially as described. 2nd. A railway car or other like vehicle provided with a side wall or walls composed in part of a portion adapted to swing outwardly and downwardly to form a wing floor and means for raising, lowering and supporting said swinging portion, a portion adapted to swing outwardly and in a direction at right angles to said floor, a portion adapted to swing outwardly from and in a direction at right angles to said last-mentioned swinging part, and a portion adapted to swing outwardly and upwardly to form a wing roof, substantially as described. 3rd. A railway car or other like vehicle provided with an extensible roof and means for raising and lowering said roof and a side wall or walls composed in part of a portion adapted to swing outwardly and downwardly to form a wing floor, substantially as described. 4th. A railway car or other like vehicle having a side wall composed of swinging portion and an extensible roof, substantially as described. 5th. A railway car or other like vehicle having a side wall composed of outwardly swinging portions and an extensible roof, substantially as described. 6th. A railway car or other like vehicle provided with an extensible roof and a side wall or walls composed in part of a swinging portion, substantially as described. 7th. A railway car or other like vehicle provided with a side wall or walls composed in part of a portion adapted to swing outwardly from the floor of the car to form a wing floor and a portion attached to and adapted to swing upwardly from said swinging portion, substantially as described. 8th. A railway car or other like vehicle provided with a side wall or walls composed in part of a portion adapted to swing downwardly and outwardly from the floor of the car to form a wing floor, a portion attached to said swinging portion at its upper end when folded, and extending inwardly at right angles thereto, a portion adapted to swing upwardly from said last-mentioned portion having attached at its lower end when folded, a portion extending outwardly at right angles thereto, a portion adapted to swing upwardly and in a direction at right angles to the roof of the car to form a wing roof and a portion adapted to swing in a direction at right angles to the wing floor, substantially as described. 9th. A railway car or other like vehicle provided with a side wall or walls composed in part of a portion adapted to swing upwardly from and in a direction at right angles to the roof of the car to form a wing roof and means for extending the same upwardly from the roof, substantially as described. 10th. A railway car or other like vehicle having a side wall composed of swinging portions adapted when opened or unfolded to form a wing and when closed to form a space or casing adapted to hold a picture or other like article, and an extensible roof, substantially as described. 11th. A railway car or other like vehicle having a side wall composed of outwardly swinging portions adapted when opened or unfolded to form a wing and when closed to form a space or casing adapted to hold a picture or other like article, and an extensible roof, substantially as described. 12th. A railway car or other like vehicle provided with a side wall composed of swinging parts adapted to be joined to the corresponding swinging parts of a side wall of a similar car to form a structure, as and for the purposes described. 13th. A railway car or other like vehicle provided with a side wall composed of parts adapted to be joined to the corresponding parts of a side wall of a similar car to form a structure, as and for the purposes described. 14th. The combination of two railway cars or other like vehicles, a part of the side wall of one being joined to the corresponding part of the side wall of the other to form a structure, as and for the purposes set forth. 15th. A railway car or other like vehicle provided with an extensible roof and a side wall or walls composed in part of an outwardly and downwardly swinging portion to form a wing floor and adapted to be moved simultaneously with the raising and lowering of the extensible roof, substantially as described. 16th. A railway car or other like vehicle provided with an extensible roof and a side wall or walls composed in part of a portion adapted to be moved simultaneously with the raising or lowering of the extensible roof, an upwardly swinging portion and a portion adapted to swing outwardly and at right angles to the car. 17th. A railway car or other like vehicle provided with an extensible roof and a side wall or walls composed in part of an outwardly and downwardly swinging portion to form a wing floor and adapted to be moved simultaneously with the raising or lowering of the extensible roof and means for producing such simultaneous result, substantially as described. 18th. A railway car or other like

vehicle provided with an extensible roof and a wing roof adapted to be raised or lowered simultaneously with the raising or lowering of said extensible roof, substantially as described. 19th. A railway car or other like vehicle provided with an extensible roof, a wing roof adapted to be raised or lowered simultaneously with the raising or lowering of said extensible roof, and means for producing such simultaneous action, substantially as described. 20th. A railway car or other like vehicle provided with an extensible roof, a wing roof adapted to be raised or lowered simultaneously with the raising or lowering of said extensible roof, an outwardly swinging portion adapted to form a wing floor and to be lowered or raised simultaneously with the raising or lowering of said extensible roof and wing roof, and means for producing such simultaneous action, substantially as described. 21st. A railway car or other like vehicle provided with a roof which is capable of being raised, and with one or more side walls that are composed partly of hinged portions capable of being raised to form wing roofs on the lower sides, in combination with two gear wheels gearing one with the other, means for operating one of the same, and suitable means actuated by the other wheel for operating ropes or chains attached to the extensible roof and also to the said movable portions of the side walls, substantially as and for the purposes hereinbefore set forth. 22nd. A railway car or other like vehicle provided with a roof which is capable of being raised, and whose side walls are partly composed of portions hinged on their upper edges and capable of being raised to form wing roofs on the lower sides, said vehicle comprising operating mechanism such as the gear wheels 22 and 23, figs. 14 to 21 inclusive and the worm 24 adapted to act (by means of a cross head such as 25 sliding in suitable guides) upon ropes such as 27 passing over pulleys 28, 29, a cross head 30 connected by ropes 31 passing over pulleys 32 to the uprights that carry the roof of the vehicle, and a rope such as 33 attached at one end to the floor of the vehicle and which after having passed over pulleys 34 mounted at the ends of movable cross beams 35 sliding in the top of the roof of the vehicle, is attached at its other end to the portions which are hinged and are adapted to form wing roofs such as *g*, figs. 14 to 21, the whole with the object of raising the movable central roof whilst raising at the same time the said movable portions *g* on the lower sides for the purpose of forming wing roofs, substantially as hereinbefore described. 23rd. A railway car or other like vehicle comprising one or more side walls partly composed of portions which are capable of swinging downwardly and outwardly so as to form a wing floor on each side of the main floor, and of other portions hinged to the first named portions and adapted to swing upwardly and outwardly perpendicularly to the said floor so as to form the lateral partitions or walls of the extended or enlarged car, substantially as described, in combination with the gear wheels and means for operating the same, a worm actuated by one of the gear wheels and operating suitably guided movable cross heads, one of which carries a pulley over which passes a rope that is attached at the end to the floor of the car and that after passing over suitable guide pulleys, is connected either to the outer end of the said portion which is adapted to form the wing floor on the lower side of the extended vehicle, or to the upper edge of the extensible portions designed to constitute the side partitions or walls of the extended car, the whole with the object of lowering or raising the said portions, substantially as hereinbefore described. 24th. A railway car or other like vehicle, whose side walls are partly composed of portions capable of swinging down so as to lengthen the floor, and of other portions capable of being raised perpendicularly to the first named portions so as to constitute side partitions or walls at the ends of the (by this means) lengthened or extended floor, the said vehicle comprising means consisting substantially of a rope such as 44, (figs. 14 to 21) passing over pulleys such as 45 and 46, and capable of passing over pulley 47, movable crossheads 39 and 41, upon one (41) of which there is mounted a pulley 42 over which the rope 44 also passes, said rope being attached at one of its ends to the fixed floor of the vehicle, and at its other end either to one or to the other of the aforesaid extensible portions, according to the circumstances of the case, and also of operating mechanism such as the gear wheels 15, 16 and the crank handles or keys 28 for operating the cross heads 16 and 20, for the purpose of lowering and raising the said extensible portions, substantially as described hereinbefore. 25th. A railway car or other like vehicle, provided with a roof capable of being raised, and with one or more side walls composed partly of portions capable of being raised so as to form wing roofs at the sides of the main roof, and partly of portions capable of being swung downward so as to lengthen the floor, and to which there are movably jointed other portions capable of being raised so as to form side walls at the sides of the floor thus lengthened, in combination with means for raising the main roof, whilst at the same time raising on the sides of the latter the portions designed to form the wing roofs, and with means for swinging down portions designed to lengthen the floor, as also for raising the extensible portions designed to constitute the side walls of the extended or enlarged car, the whole substantially as hereinbefore described and as illustrated in figs. 14 to 21 inclusive of the accompanying drawings and for the purposes set forth.

No. 56,165. Floor Clamp. (Crampon pour planchers.)

Frank F. Soule, Mansonville, Quebec, Canada, 7th June, 1897; 6 years. (Filed 11th May, 1897.)

Claim. In a floor clamp, the combination with the frame of a

toggle having one member pivoted to the frame, the other member carrying a floor clamping plunger mounted for reciprocation in the

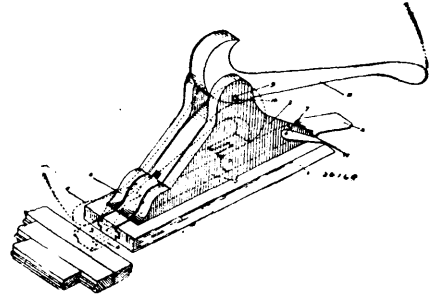

base of the frame, a spring for contracting said toggle, a cam lever for depressing the same, and a trust dog, substantially as described.

No. 56,166. Caster. (Roulette de meubles.)

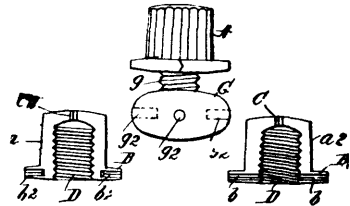

George William Phillips, New York, State of New York, U.S.A., 7th June, 1897; 6 years. (Filed 13th May, 1897.)

Claim.—1st. An attachment for the legs of billiard tables, and other heavy articles of furniture, which comprises a socket or tubular casing which is adapted to be inserted into the end of said legs, said socket or tubular casing being composed of two similar parts, and provided with a screw-threaded bore, and an adjustable attachment connected therewith, consisting of a head provided with a screw-threaded shank, substantially as shown and described. 2nd. An attachment for the legs of billiard tables, and other heavy articles of furniture, which comprises a socket or tubular casing which is adapted to be inserted into the end of said legs, said socket or tubular casing being composed of two similar parts, and provided with a screw-threaded bore, and an adjustable attachment connected therewith, consisting of a head provided with a screw-threaded shank, and said head being provided with radial holes or openings in the sides thereof, substantially as shown and described. 3rd. An attachment for the legs of billiard tables, and other heavy articles of furniture, which comprises a socket or tubular casing which is adapted to be inserted into the end of said legs, said socket or tubular casing being composed of two similar parts, and provided with a screw-threaded bore, and an adjustable attachment connected therewith, consisting of a head provided with a screw-threaded shank, and said head being also provided with a caster which is connected therewith, substantially as shown and described.

No. 56,167. Dust-Bag Frame and Handle. (Receptacle pour la poussière.)

(Receptacle pour la poussière.)

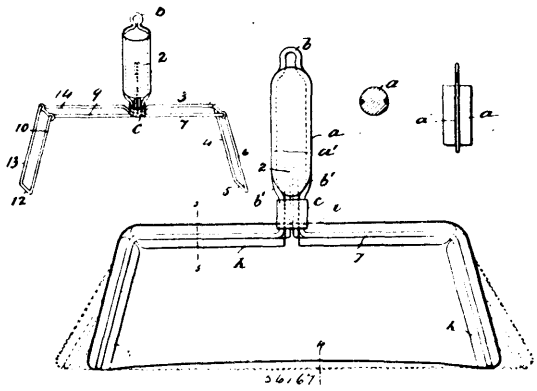

David Hunt, Boston, Mass., U.S.A., 7th June, 1897; 6 years. (Filed 10th May, 1897.)

Claim.—1st. The dust-bag or dust-pan herein described, having an extensible supporting-frame and a flexible lip or edge strip connected thereto, and adapted to be drawn and held taut by extending said supporting frame, substantially as described. 2nd. The

dust-bag or dust-pan herein described, having an elastic supporting-frame, and a flexible lip or edge strip connected thereto, and curved longitudinally, and adapted to be straightened out by extending said frame, substantially as described. 3rd. The elastic supporting frame comprising a top portion and two outwardly projecting side portions, a handle attached to the top portion, and a flexible lip or edge strip connected with said frame, and adapted to be drawn and held taut between the lower ends of the side portions by pressure upon the frame, substantially as described. 4th. The extensible supporting-frame, comprising a top portion and two outwardly projecting side portions, a handle attached to the top portion, and a flexible lip or edge strip consisting of a metallic edge, and a belt to which it is applied, said strip being supported upon said frame and adapted to be drawn to conform to irregularities by pressure upon the frame, substantially as described. 5th. The extensible supporting-frame comprising a top portion and two outwardly projecting side portions, a handle attached to the top portion, and a belt encircling the frame, and having a metallic edge between the lower ends of the side portions, and a flexible bag attached to said belt, substantially as described. 6th. The supporting-frame and attached handle herein described, consisting of the block *a*, socketed at one end and having grooved sides, a wire bent to form a supporting-frame and to enter the grooves in the sides of the block *a*, the ends of said wire entering the socket in said block *a*, and being thereby secured, substantially as described. 7th. The supporting-frame and attached handle herein described, consisting of the block *a*, socketed at one end and having grooved sides, a wire bent to form a supporting-frame and to enter the grooves in the sides of the block *a*, and also to form an eye at the outer end of the block *a*, substantially as described. 8th. The supporting-frame and attached handle herein described, consisting of the block *a*, socketed at one end and having grooved sides, a wire bent to form a supporting-frame and to enter the grooves in the sides of the block *a*, the ends of said wire entering the socket in said block *a*, and being thereby secured, and a ferrule or clamp near the lower end of the block *a* through which the wire passes back and forth, substantially as described. 9th. The handle consisting of the block *a*, having grooved sides, and the wire embracing it, entering the grooves in its sides, and formed at one end with an eye, and projecting a short distance beyond the block at the opposite end for connection with a frame, substantially as described. 10th. The handle consisting of the block *a*, having grooved sides, and a wire adapted to enter said side grooves, and formed at one end with an eye, substantially as described.

No. 56,168. Sheet Metal Can.

(*Bidon en feuille metallique.*)

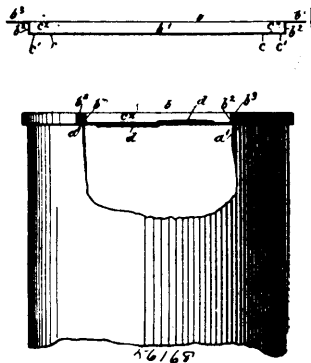

Max Ams, New York, State of New York, U.S.A., 7th June, 1897; 6 years. (Filed 10th May, 1897.)

Claim.—A can cover having a vertical neck or wall, a laterally extending flange which forms a lap joint with the top edge of the can; and provided with two indented or weakened concentric circles that form a ring between them, the outer circle being formed at the base of the vertical neck or wall; combined with the can, having a flange at its top over which the flange on the cover forms a lap joint; and a tongue secured to one end of the ring through a cut therein, the tongue being protected by the chime of the can body, substantially as set forth.

No. 56,169. Wagon Brake. (*Frein de wagons.*)

Calvin Craig Long, Washington, Iowa, U.S.A., 8th June, 1897; 6 years. (Filed 7th May, 1897.)

Claim.—1st. The combination with a lever adapted to be attached at the side of a wagon, of a lever frame provided with a horizontally-projecting stud on which the lever is fulcrumed, said stud having a concaved exterior adapted to enter a corresponding hole in the lever, said lever being provided with longitudinal tapering edges, and an arc-shaped ratchet disposed below the fulcrum of the lever, as and for the purposes set forth. 2nd. The combination in a

wagon-brake of a frame adapted to be secured to the side of the wagon-body, said frame consisting of a horizontal bar provided with

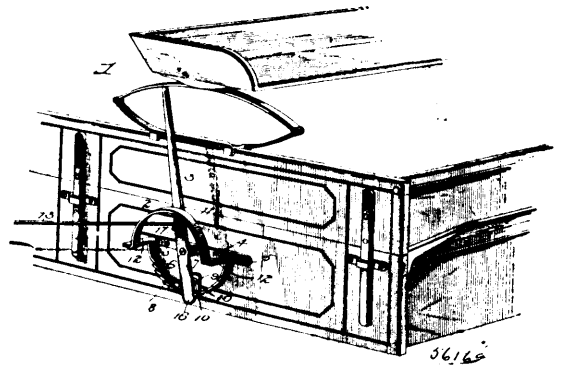

a stud, an arc-shaped bar arising from horizontally-extending arms, an arc-shaped ratchet secured to and projecting downwardly from said arms, and a lever fulcrumed in the frame, and having the longitudinal edges of its lower end bevelled to engage the ratchet, substantially as described.

No. 56,170. Axle. (*Essieu.*)

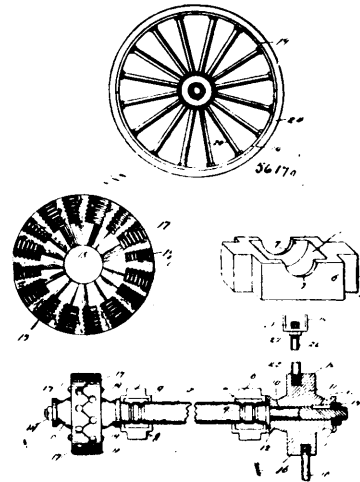

Albert Grovers and John August Swenson, both of New York, State of New York, U.S.A., 8th June, 1897; 6 years. (Filed 6th May, 1897.)

Claim.—1st. A wheel comprising a hub, which is divided transversely, the separate parts thereof being provided with spoke holes and being also adapted to interlock, and a fellow through which the outer ends of the spokes pass, said outer ends of the spokes being screw-threaded and provided with nuts or burrs, substantially as shown and described. 2nd. A wheel comprising a hub which is divided transversely, the separate parts thereof being provided with spoke holes and being also adapted to interlock, and a fellow through which the outer ends of the spokes pass, said outer ends of the spokes being screw-threaded and provided with nuts or burrs, and said fellow being U-shaped in cross-section and composed of separate parts, substantially as shown and described. 3rd. The herein described bearings or journal boxes, for a vehicle axle, said axle being provided with the usual spindles, and with wheels mounted thereon, one of said wheels being keyed to the axle and the hubs of said wheels being divided transversely and the separate sections thereof being provided with spoke holes in which the inner ends of the spokes are placed before the separate parts of the hub are bolted together, substantially as shown and described. 4th. A wheel comprising a hub which is divided transversely, and the separate parts of which are provided in their adjacent faces with spoke holes, said separate parts being adapted to interlock, and the spoke holes being arranged alternately on opposite sides of a central transverse line, and said separate parts being folded together, and a fellow through which the outer ends of the spokes pass, said outer ends of the spokes being screw-threaded and provided with nuts or burrs, substantially as shown and described. 5th. The herein-described journal-box for the axle of a vehicle, said axle being provided with the usual spindles and with wheels mounted thereon, said journal-boxes being arranged adjacent to the hubs of said

wheels, and said axle being provided with washers adjacent to said journal boxes, and said hubs being provided with rims within which said washers fit, substantially as shown and described.

No. 56,171. Journal Box or Bearing.

(*Coussinet de tourillons.*)

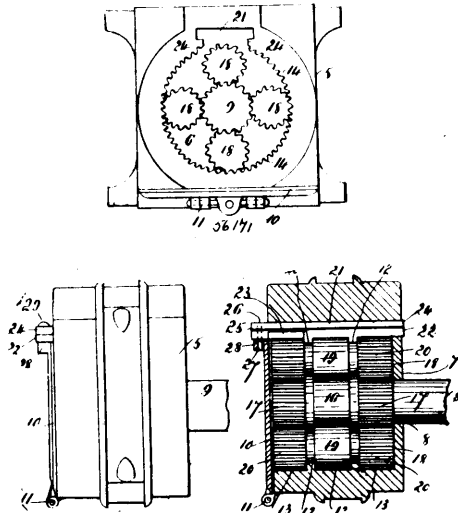

Erwin Harrison Spencer, Grayling, Michigan, U.S.A., 8th June, 1897; 6 years. (Filed 6th May, 1897.)

Claim.—1st. A bearing for shafts and axles, comprising a box or casing having a central circular chamber formed therein, which is open at one end and the opposite end of which is provided with a central circular opening through which the shaft or axle passes, the walls of said circular chamber being provided with two inwardly directed annular ribs or flanges, whereby said walls are divided into three annular spaces, a shaft or axle which passes through the circular opening in the end of the box or casing, and which is provided with two collars or annular flanges, said shaft or axle being provided outside said collars or flanges with cogs or gear teeth, and a plurality of rollers mounted in said box or casing around said shaft or axle, said rollers being provided with two annular grooves, which are adapted to receive the ribs or flanges formed in the walls of the circular chamber, and those formed on the shaft or axle, and the ends of said rollers being provided with cogs or gear teeth, which correspond with those formed on the shaft or axle, and which operate in connection therewith, substantially as shown and described. 2nd. A bearing for shafts and axles, comprising a box or casing having a central circular chamber formed therein, which is open at one end and the opposite end of which is provided with a central circular opening through which the shaft or axle passes, the walls of said circular chamber being provided with two inwardly directed annular ribs or flanges, whereby said walls are divided into three annular spaces, a shaft or axle which passes through the circular opening in the end of the box or casing, and which is provided with two collars or annular flanges, said shaft or axle being provided outside said collars or flanges with cogs or gear teeth, and a plurality of rollers mounted in said box or casing around said shaft or axle, said rollers being provided with two annular grooves, which are adapted to receive the ribs or flanges formed in the walls of the circular chamber, and those formed on the shaft or axle, and the ends of said rollers being provided with cogs or gear teeth, which correspond with those formed on the shaft or axle, and which operate in connection therewith, and the annular chambers formed at each end of the circular chamber by the inwardly directed flanges or ribs in the walls thereof, being also provided with cogs or gear teeth which correspond with those formed on the ends of the rollers, and which operate in connection therewith, substantially as shown and described. 3rd. A bearing for shafts and axles, comprising a box or casing having a central circular chamber formed therein, which is open at one end, and the opposite end of which is provided with a central circular opening through which the shaft or axle passes, the walls of said circular chamber being provided with two inwardly directed annular ribs or flanges, whereby said walls are divided into three annular spaces, a shaft or axle which passes through the circular opening in the end of the box or casing, and which is provided with two collars or annular flanges, said shaft or axle being provided outside said collars or flanges with cogs or gear teeth, and a plurality of rollers mounted in said box or casing around said shaft or axle, said rollers being provided with two annular grooves, which are adapted to receive the ribs or flanges formed in the walls of the circular chamber, and those

formed on the shaft or axle, and the ends of said rollers being provided with cogs or gear teeth, which correspond with those formed on the shaft or axle, and which operate in connection therewith, and the annular chambers formed at each end of the circular chamber by the inwardly directed flanges or ribs in the walls thereof, being also provided with cogs or gear teeth which correspond with those formed on the ends of the rollers and which operate in connection therewith, and said box or casing being provided with a hinge door, which is adapted to cover the open end of the circular chamber, substantially as shown and described. 4th. A bearing for shafts and axles, comprising a box or casing having a central circular chamber formed therein, which is open at one end and the opposite end of which is provided with a central circular opening through which the shaft or axle passes, the walls of said circular chamber being provided with two inwardly directed annular ribs or flanges, whereby said walls are divided into three annular spaces, a shaft or axle which passes through the circular opening in the end of the box or casing, and which is provided with two collars or annular flanges, said shaft or axle being provided outside said collars or flanges with cogs or gear teeth, and a plurality of rollers mounted in said box or casing around said shaft or axle, said rollers being provided with two annular grooves, which are adapted to receive the ribs or flanges formed in the walls of the circular chamber, and those formed on the shaft or axle, and the ends of said rollers being provided with cogs or gear teeth, which correspond with those formed on the shaft or axle, and which operate in connection therewith, and the annular chambers formed at each end of the circular chamber by the inwardly directed flanges or ribs in the walls thereof, being also provided with cogs or gear teeth which correspond with those formed on the ends of the rollers, and which operate in connection therewith, and said box or casing being provided with a hinge door which is adapted to cover the open end of the circular chamber, and said circular chamber being provided in one side thereof, with a transverse chamber which is adapted to be filled by the plate after the rollers have been placed in position, said plate being formed on its inner surface, to correspond with the walls of the circular chamber, being provided at each end with cogs or gear teeth, and with a central smooth portion, and means for holding said plate in position, substantially as shown and described.

No. 56,172. Sweeping Machine. (*Balayeuse.*)

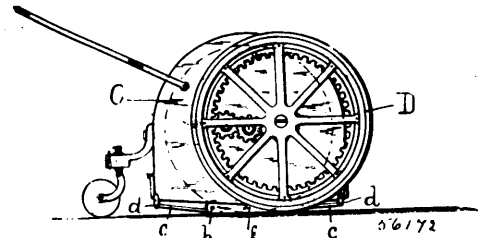

Onondaga Sweeper Co. and Franklin Baylis, John Seegle Hitchcock and Franklin Baylis, all of Syracuse, New York, U.S.A., 8th June, 1897; 6 years. (Filed 1st May, 1897.)

Claim.—1st. The combination with the rotary brush and its enclosing case, of two driving-wheels respectively on opposite sides of said case, an internally toothed gear on each of said wheels, a pinion on each end of the brush-shaft, and intermediate pinions transmitting motion from the internally toothed gears to the pinions of the brush-shaft, as set forth. 2nd. The combination with the rotary brush and its enclosing-case, of two driving-wheels respectively on opposite sides of said case and carrying the same, an internally toothed gear on each of said wheels, two pinions pivoted respectively to opposite sides of the case and provided with tubular hubs, the brush-shaft extending into said hubs and journalled therein by interposed anti-friction ball-bearings, pawl and ratchet mechanisms transmitting motion in one direction from said pinions to the brush-shaft, and intermediate pinions transmitting motion from the internally toothed gears to the pinions of the brush-shaft, as set forth. 3rd. The combination with the rotary brush, its enclosing-case and dust-pan, of guard-plates separate from the dust-pan and extending along the sides of the case at the bottom thereof and connected to the case by vertically yielding supports allowing said plates to conform to the unevenness of the floor and close the spaces under the sides of the case independently of the dust-pan, as set forth. 4th. The combination of the rotary brush, its enclosing-case and dust-pan, of vertically yielding guard-plates separate from the dust-pan and extending along the bottoms of the sides of the case and along the receiving edge of the dust-pan and over said edge, said guard-plates being connected to the case by vertically yielding supports to allow them to move vertically without disturbing the dust-pan and to conform to the unevenness of the floor and by maintaining contiguous thereto confine the sweepings in the case and conducting them to the dust-pan as set forth. 5th. The combination with the rotary brush, its enclosing-case and dust-pans, respectively, in the front and rear portions of said case, of bottom guard-plates extending across the case beneath the dust-pans and hinged to the case, respectively, adjacent to the front and rear thereof, side guard-plates pivotally con-

ned at their ends to the aforesaid bottom guard-plates adjacent to the inner edges thereof, and inclined dust-guiding flanges extending from the inner edge of the latter plates part way over the dust-pans, substantially as shown and described.

No. 56,173. Pipe Joint and Conduit.
(*Joint de tuyau et conduit.*)

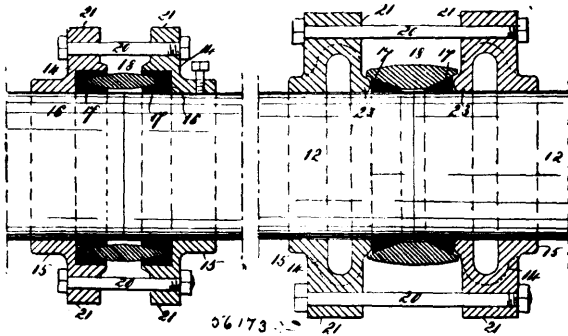

Nimrod Simmons, Bristol, Gloucester, Great Britain, 8th June, 1897; 6 years. (Filed 10th May, 1897.)

Claim.—1st. The herein described pipe joint, the same consisting of packing material placed at or adjacent to the point where the joint is to be made, and means for compressing said material so as to make a tight joint, substantially as shown and described. 2nd. A coupling or joint for pipes, the same consisting of two rings or bands, a binding ring placed between the same, and packing material adjacent to said binding ring, and means for compressing said packing material upon the pipe or the sections thereof, by drawing said rings or bands together, substantially as shown and described. 3rd. The herein described coupling device for pipes, the same consisting of two rings or bands provided with projecting shoulders or jaws through which are passed bolts provided with nuts or burrs, a binding ring placed between said rings or bands, and packing material used in connection with said binding ring, and adapted to be compressed upon the pipes or the separate sections thereof, by drawing the said rings or bands together, substantially as shown and described. 4th. The herein described coupling for pipes, the same consisting of two rings or bands through which the sections of pipe to be coupled are passed, said rings or bands being provided with rabbet grooves in their adjacent sides in which are placed packing material, and a binding ring placed between said rings or bands and provided with outwardly directed flanges or rims which are adapted to be formed into said packing material when said rings or bands are drawn together, substantially as shown and described. 5th. The herein described coupling for pipes, the same consisting of two rings or bands through which the sections of pipe to be coupled are passed, said rings or bands being provided with rabbet grooves in their adjacent sides in which are placed packing material, and a binding ring placed between said rings or bands and provided with outwardly directed flanges or rims which are adapted to be forced into said packing material, when said rings or bands are drawn together, said rings or bands being provided with projections or jaws through which are passed bolts, substantially as shown and described.

No. 56,174. Sleigh Knee. (*Courbe pour traîneaux.*)

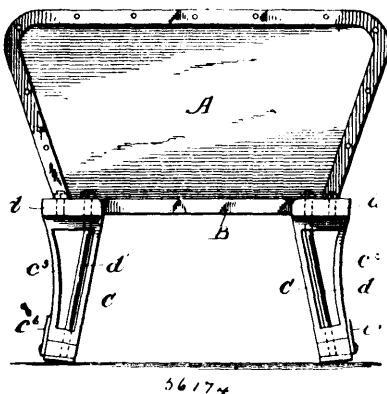

Byron Wallace Kellogg, Vernonville, Ontario, Canada, 8th June, 1897; 6 years. (Filed 8th May, 1897.)

Claim.—In a sleigh knee, the combination with a flanged box or casting adapted to be secured to one of the sleigh beams, and provided with bolt apertures in its bottom, of spaced inclined braces secured to the under side of said box at its opposite edges, and each com-

prising a main supporting bar and a bracing bar extending at an angle thereto, an angular attaching plate secured to the lower end of said braces and provided with extended apertured ears, a bolt adapted to be passed through the runner, said angular plate, the box or casting and the sleigh beam, and suitable rivets adapted to be passed through the apertures of the extended ends and the sleigh runners, substantially as described.

No. 56,175. Saw. (*Scie.*)

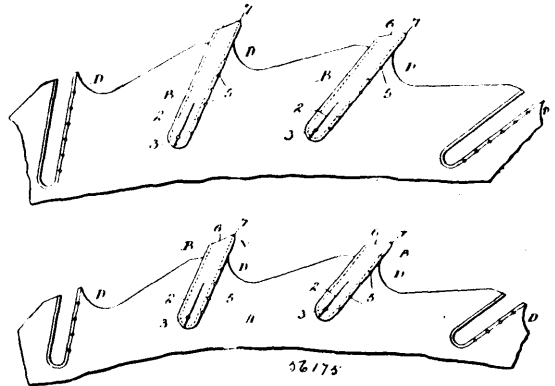

Dewey Phillips, East Arlington, Vermont, U.S.A., 8th June, 1897; 6 years. (Filed 8th May, 1897.)

Claim.—1st. A removable tooth for a saw plate, having a bevelled end and grooved edges with cutting edges at the sides of the tooth at or near the outer end, and an intermediate straight cutting or chisel edge between such side cutting edges, substantially as set forth. 2nd. A removable saw tooth having a bevelled end, a substantially straight cutting edge to clear the wood from the kerf, and side cutting edges to plane the surfaces of the wood at the opposite sides of the kerf, substantially as set forth.

No. 56,176. Process for the Treatment of India-Rubber. (*Procédé pour le traitement du caoutchouc.*)

Eugen Hormung and Stefan Hansel, both of Vienna, Austria, 8th June, 1897; 6 years. (Filed 10th May, 1897.)

Claim.—1st. A process for preventing india-rubber, gutta percha and their compositions from becoming hard and brittle, such process consisting in mixing the india-rubber, gutta percha or a composition of the same, before it is vulcanized and treated, with a plastic mass consisting of a mixture of precipitated gelatine or glue insoluble in water and vulcanized oil preferably swelled with a hydrocarbon, substantially as hereinbefore described. 2nd. As a new article of manufacture, india-rubber, gutta percha or a composition of the same mixed as hereinbefore described with precipitated insoluble gelatine or glue in the form of a plastic mass to prevent it from becoming hard and brittle.

No. 56,177. Car Fender. (*Défense de chars.*)

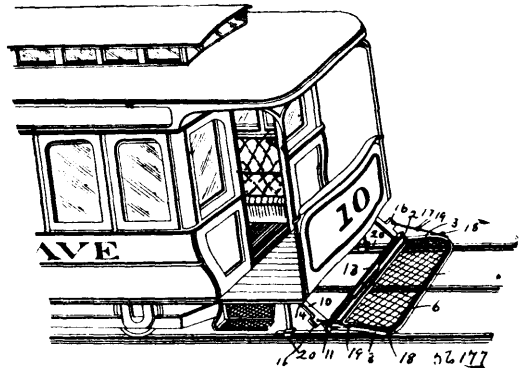

Susan Frances Moore, Peabody, Mass., U.S.A., 8th June, 1897; 6 years. (Filed 8th May, 1897.)

Claim.—1st. In a car fender, a pair of arms adapted to pass under the car and to be detachably connected to the bottom of a car beneath the platform thereof, and a cross bar connecting the free ends of said arms, in combination with a scoop pivotally connected to said cross bar, and braces interposed between said scoop and arms, and arranged below the plane of the platform, substantially as and for the purpose specified. 2nd. In a car fender, a pair of arms adapted to be detachably connected to the bottom of a car beneath the platform thereof, a cross bar connecting the front ends of said arms, a scoop pivotally connected to said cross bar, braces interposed

between said scoop and arms, a slide frame connected to the scoop frame and extending beneath the car platform, hangers under the car with which said slide frame has a sliding connection and fastening means for said slide frame, substantially as described. 3rd. In a car fender, the combination with spaced and substantially parallel supporting arms arranged beneath the car platform and connected at their front ends by a cross bar having its forward edge turned downward and its rear edge turned upward to form a transverse stop shoulder, of a scoop frame pivotally connected to said cross bar on its upper side and bearing against the down-turned edge thereof, the said edge forming a rest for holding the scoop frame in proper working position, and the upturned rear edge of said car serving to take the back thrust of the scoop frame when subjected to a sudden shock, substantially as described. 4th. In a car fender, a transverse beam secured to the under side of the car and provided with spaced openings, in combination with spaced parallel supporting arms having their rear ends reduced and removably fitted in the said openings, a cross bar connecting said arms at their forward ends, a scoop frame pivotally connected at its rear edge to said cross bar, and one or more braces interposed between said arms and lateral ears on the side bars of the scoop frame, all arranged for joint operation, substantially as described.

No. 56,178. Pumping Machine. (Pompe.)

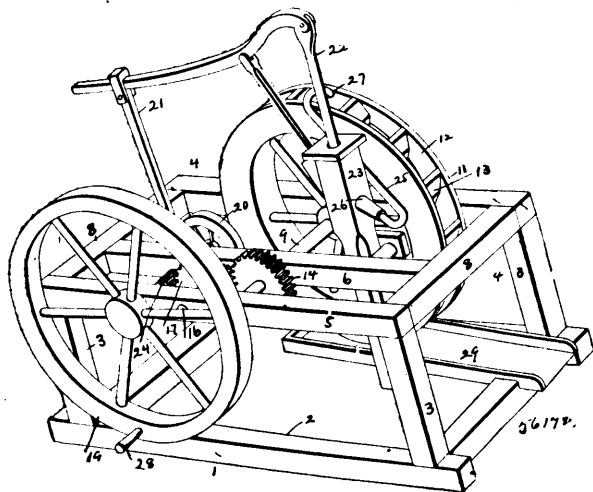

John George Gigueux, Dubberley Station, Louisiana, U.S.A., 8th June, 1897; 6 years. (Filed 8th May, 1897.)

Claim.—1st. The combination with a suitable support, of a water wheel, and mechanism operatively connected with the water wheel and designed to be actuated thereby to project a column of water upon the water wheel, substantially as specified. 2nd. The combination with a suitable support, of a power shaft, a water wheel thereon, a gear wheel upon the shaft, a second shaft, a pinion upon said shaft engaging the gear wheel on the power shaft, a gear wheel upon said second shaft, a pump shaft, a pinion upon the power shaft engaging the last named gear wheel, and mechanism carried by the pump shaft and designed to connect said pump shaft with mechanism for elevating water, substantially as specified. 3rd. The combination with a suitable support, of a power shaft, a water wheel upon the power shaft provided with a peripheral groove and transverse inclined buckets, a pump shaft operatively connected with the power shaft through intermediate gears, mechanism designed to elevate water and discharge it upon the water wheel, and mechanism intermediate the power shaft and the water elevating mechanism, substantially as specified. 4th. The combination with the water wheel, a pump comparatively connected with the water wheel, of a pipe extending from the pump and provided with an angular nozzle above the water wheel, substantially as specified. 5th. The combination with a suitable support, of a power shaft, a water wheel carried by the power shaft, and brake mechanism operatively connected with the power shaft, substantially as specified. 6th. The combination with a suitable support, of a power shaft, an adjustable brake shoe in operative relation with the power shaft and water wheel, and a water wheel mounted upon said shaft, a pump shaft, a train of gears intermediate the pump shaft and the gear wheel on the power shaft, a fly wheel provided with a handle and keyed upon the pump shaft, a pump wheel likewise keyed upon the pump shaft, means for operatively connecting the pump wheel to the pump, and a pipe designed to convey the water from the pump and to discharge it upon the water wheel, substantially as specified. 7th. The combination with a suitable support, of a power shaft, a brake cap provided with a brake shoe in operative relation with the power shaft, compression screws passing through the brake cap and into the support, a water wheel carried by the shaft provided with a peripheral groove, and a series of angular buckets within said groove, a water wheel carried by the power

shaft, a second shaft provided with a pinion in mesh with said gear, a second gear wheel upon the second shaft, a pump shaft provided with a pinion in mesh with said last named gear, a fly wheel upon one extremity of the pump shaft, a pump wheel upon the opposite extremity of the pump shaft, a pump operatively connected with the pump wheel, a water pipe extending from the pump and provided with an inclined nozzle end above the water wheel, and a chute below the water wheel designed to receive the water therefrom, substantially as specified.

No. 56,179. Stop Valve. (Soupape d'arrêt.)

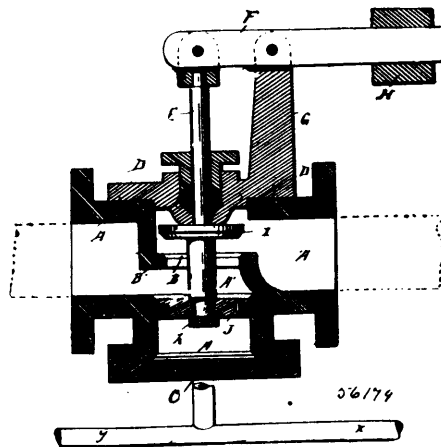

John Seymour Dodge, Mayersville, Mississippi, U.S.A., 8th June, 1897; 6 years. (Filed 6th May, 1897.)

Claim.—1st. The combination with the body portion of the valve casing, of a pipe leading from the end of the cylinder of said casing and connected to the steam pipe, a pipe leading from the same end of the cylinder to the steam-drum, a cap with stuffing-box, a valve-stem passed through said box, a lever fulcrumed on a standard rising from said cap and pivotally connected with said stem, a disc I upon said stem upon one side of the valve-seat, a piston on said stem on the other side of said seat, and a stop-nut on the end of the stem in line with the opening in the end of the cylinder, all substantially as shown and described and for the purpose specified. 2nd. The combination with the body portion of the valve casing, of a pipe leading from the end of the cylinder of said casing and connected to the steam-pipe, a pipe leading from the same end of the cylinder to the steam-drum, a cap with stuffing-box, a valve-stem passed through said box, a lever fulcrumed on a standard rising from said cap and pivotally connected with said stem, a disc I upon said stem upon one side of the valve-seat, a piston on said stem on the other side of the said seat, a stop-nut on the end of the stem in line with the opening in the end of the cylinder, and independent valves in said pipes upon opposite sides of the opening in the end of the cylinder, substantially as described. 3rd. The combination with the body portion of the valve-casing, of a pipe leading from the end of the cylinder of said casing and connected to the steam-pipe, a pipe leading from the same end of the cylinder to the steam-drum, a cap with stuffing-box, a valve-stem passed through said box, a lever fulcrumed on a standard rising from said cap and pivotally connected with said stem, a disc I on said stem on one side of the valve-seat, a piston on said stem on the other side of the said seat, a stop-nut on the end of the stem in line with the opening in the end of the cylinder, and independent valves in said pipes upon opposite sides of the opening in the end of the cylinder, the body portion having connection with the boiler on the side of the valve-seat, substantially as described.

No. 56,180. Means for Securing Cams to Shafts. (Moyen d'assujettir les cames aux arbres.)

Edward Anderson Blanton, jr., London, England, 8th June, 1897; 6 years. (Filed 11th May, 1897.)

Claim.—1st. A shaft having a series of eccentric bosses arranged around its circumference, in combination with a hub having a series of eccentric recesses adapted to engage the bosses, substantially as described. 2nd. A shaft having a series of eccentric bosses extending longitudinally of the shaft and arranged around its circumference, in combination with a series of hubs each having a series of eccentric recesses corresponding to the bosses on the shaft, substantially as described. 3rd. A shaft having a series of eccentric bosses

arranged around its circumference and extending longitudinally of the shaft and having plain surfaces interposed between the extremi-

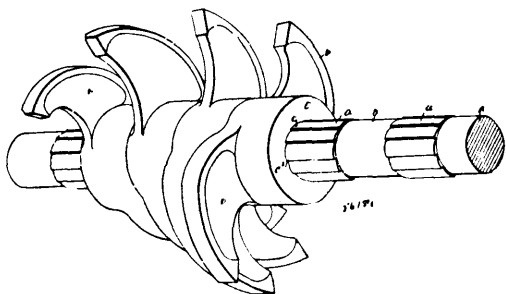

ties of the bosses, in combination with a series of hubs having eccentric recesses corresponding to the eccentric bosses, substantially as described. 4th. A shaft having a series of eccentric bosses, the outer surfaces of which are in the form of an involute curve, in combination with a hub having a series of recesses the surfaces of which correspond to the external surfaces of the bosses, substantially as described.

No. 56,181. Toe Weight. (Contre-poids de sabots.)

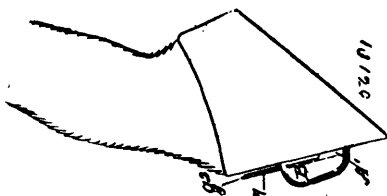

Griffith D. Williams, Peckville, Pennsylvania, U.S.A., 8th June, 1897; 6 years. (Filed 7th May, 1897.)

Claim.—1st. The herein described toe-weight, consisting of an inverted T-shaped clip or spur adapted to be secured to the hoof and having its vertical arm or spur offset from the hoof a short distance and inclined backwardly with respect thereto, and the weight proper having upon its rear side a loop or seat designed to slidingly engage the said arm, and recessed or cutaway at its lower portion to receive the transverse or head portion of the spur, said weight being retained in place upon the spur solely by friction, its own gravity, and the backward inclination of said vertical arm, substantially as specified. 2nd. The combination with the inverted T-shaped clip or spur adapted to be secured upon the hoof of a horse, and having its vertical arm of slightly spring character and inclined backwards, or towards the hoof, the vertical and transverse edges of said clip or spur having a receding bevel, of a weight having a bevelled-wall recess to seat the transverse or head portion of said clip or spur, and a bevelled-wall groove or opening for engagement with the vertical arm of the same, substantially as specified.

No. 56,182. Collapsible Box. (Boite pliante.)

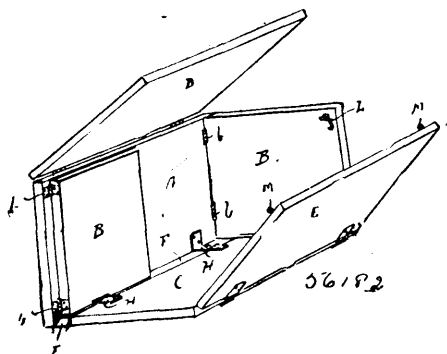

Herbert A. Cobleigh, Ozone Park, New York, U.S.A., 8th June, 1897; 6 years. (Filed 6th May, 1897.)

Claim.—A collapsible or folding box or crate, substantially as herein shown and described, consisting of a back A, ends B, a bottom C, front E and a top or cover D, said back A having secured along one edge thereof, a strip F to which the bottom is hinged, the ends B being hinged to the back A, and adapted to be folded there-upon over the strip F, which strip is secured in position by angular plates G, to one end of which plates are secured the hinges H at-

taching the back A to the bottom C, the top B and the front E, being provided with three-plate hinges K, and the ends B having secured thereto hooks L to retain the front E in connection therewith, all constructed and arranged as herein specified.

No. 56,183. Seine Needle. (Aiguille pour seines)



William J. May, Homosassa, Florida, U.S.A., 8th June, 1897; 6 years. (Filed 6th May, 1897.)

Claim.—1st. A seine-needle having its body provided with a longitudinal recess 6, a plate 9 having the flange 10 for covering said recess, and a knife-blade 8 having an expanded curved cutting end 13, substantially as described. 2nd. A seine-needle, having its body, at one side of the eye therein, provided with a longitudinal recess 6, and a knife-blade 8 having an expanded curved cutting end 13, corresponding in shape and size approximately to one-half of the point of the needle, substantially as described.

No. 56,184. Sash Fastener. (Arrête-croisée.)

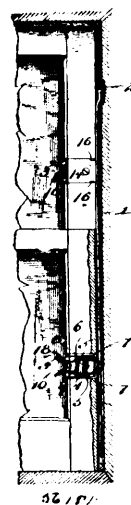

Frank Bogart Townsend, Penn Yan, New York, U.S.A., 8th June, 1897; 6 years. (Filed 5th May, 1897.)

Claim.—1st. An improved sash-fastener comprising a suitable casing, a cross-flange or web disposed within the same and provided with transverse slots or notches, a pair of finger levers extending through and slidably mounted and fulcrumed in said slots or notches and having their outer ends perforated to engage a supporting-rod, a pin passing through aligning perforations in said levers and headed at its extremities, and a spiral spring surrounding said pin and interposed between said levers, all combined and arranged substantially as and for the purpose specified. 2nd. In a sash-fastener, a suitable casing, a pair of levers fulcrumed therein and perforated to engage a supporting-rod, a spring for holding said levers in engagement with the supporting-rod, and a locking plate pivotally mounted within the casing at or near one end thereof and provided with shoulders or catches for engaging said levers and holding the same out of engagement with the supporting rod, the same being combined and arranged substantially as set forth.

No. 56,185. Tea Infuser. (Appareil à infuser le thé.)

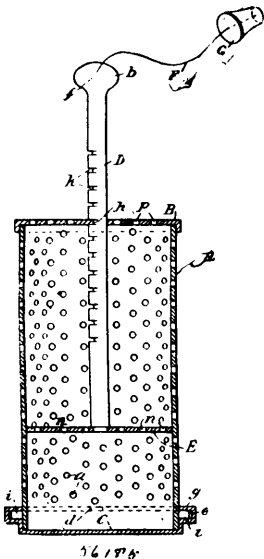

John Henry Sutthoff, Seattle, Washington, U.S.A., 8th June, 1897; 6 years. (Filed 15th May, 1897.)

Claim.—1st. In a tea infuser, a perforated cylinder, a measuring piston adjustably located therein with means for locking it in its adjusted position, and a movable cap for said cylinder, substantially as described. 2nd. In tea infusers, a perforated cylinder A, provided at one end with a perforated cover B, permanently attached thereto and provided with an opening *h*, of elliptical form and at the other end with oppositely arranged pins or projections *i*, a rod D, operating in the opening *h*, of cover B, and provided at one end with knob *b*, and with slots *k*, cut across one edge and a perforated piston E, attached to the opposite end and operating in cylinder A, being capable of adjustment therein to different measures by said slots *k*, of rod D, adapted to engage the perimeter of said opening *h*, a removable cover C, provided with slots *d*, and attached to the end of the cylinder A, by the engagement of slots *d*, with the pins *i*, providing for the introduction and retaining of tea leaves substantially as described. 3rd. In a tea infuser, a perforated holder, the adjustable piston with its rod, and the float attached to the infuser by a cord, substantially as described. 4th. The improvements in tea infusers herein shown and described including the perforated holder having the removable cap and the follower piston with its rod having the slots by which the piston may be adjusted. 5th. In a tea infuser, a perforated cylinder, a piston adjustable therein and having notches to engage internal pins or projections on the cylinder, and a removable cap having slots adapted to engage external pins on the cylinder, substantially as described. 6th. In a tea infuser, a perforated cylinder, a piston longitudinally adjustable therein, guides carried by the piston, slotted bars connected to the edges of the piston, said guides having notches to engage internal pins on the cylinder and a removable cap having slots to engage external pins on the cylinder, substantially as described.

No. 56,186. Cutter Head. (Porte-outil.)

William H. Holder, Jacob W. Walters, Richard H. Heffelfinger and Samuel F. McKeehan, all of Scranton, Pennsylvania, U. S. A., 8th June, 1897; 6 years. (Filed 21st April, 1897.)

Claim.—1st. In a cutter-head, the combination of the cutter-stocks in sliding engagement with the head and carrying cutters adapted to be projected beyond one side of said head; together with lugs on the driving-shaft and engaging the cutter-stocks to move them alternately in opposite directions, for the purpose set forth. 2nd. In a rotary cutter, the combination of the cutter-head having heads B and B¹, provided with transverse recesses or grooves; cutter-stocks provided at their ends with webs or splines in engagement with said transverse recesses and carrying cutters adapted to be projected beyond one side of said cutter-head; together with lugs on the driving-shaft and in engagement with the cutter-stocks for moving them alternately in opposite directions, for the purpose set forth. 3rd. In a rotary cutter, the combination, of the cutter-head having heads B and B¹, provided with transverse recesses or grooves; cutter-stocks mounted between said heads and provided at their ends with webs or splines in engagement with said transverse recess, the cutter stocks being provided with recesses and carrying cutters adapted to be projected beyond one side of the cutter-head; and lugs on the driving-shaft in engagement with the recesses in the cutter-stocks for moving them alternately in opposite directions, for the purpose set forth. 4th. In a rotary cutter, the combination with the driving-shaft A having lugs projecting from opposite sides thereof, of heads B and B¹,

mounted on said shaft and held in places by collars *a* and *a*¹, said heads being provided with transverse grooves; cutter-stocks

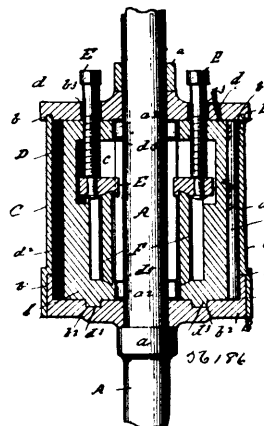

mounted between the heads and provided at their ends with webs or splines in engagement with the transverse recesses, the lugs on the driving-shaft engaging recesses in the cutter-stocks, substantially as shown and for the purpose set forth. 5th. In a rotary cutter, the combination with the driving-shaft A having lugs projecting from opposite sides thereof, of the heads B and B¹, mounted on said shaft and provided on their inner sides with transverse recesses or grooves; a cylinder connecting the heads to each other; and cutter-stocks mounted in the cylinder between the heads B and B¹, and provided with webs or splines in engagement with the transverse recesses therein, the cutter heads having recesses with which the lugs on the shaft engage, substantially as shown and for the purpose set forth. 6th. In a rotary cutter, the combination with the driving-shaft A having lugs projecting from opposite sides thereof, of heads, as B and B¹, mounted on said shaft, and cutter-stocks located between the heads and in movable engagement therewith, the cutter-stocks having recesses which receive the shaft and permit a limited movement of said cutter-stocks, the cutter-stocks being also provided with recesses with which the lugs on the shaft engage, substantially as shown and for the purpose set forth.

No. 56,187. Vehicle Spring. (Ressort de voitures.)

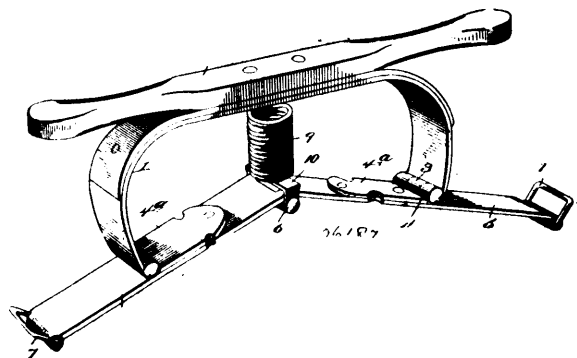

Seth Marion Moore and Delbert L. Larsh, both of Norman, Oklahoma, U.S.A., 8th June, 1897; 6 years. (Filed 5th May, 1897.)

Claim.—1st. In a device of the class described, the combination of a transverse spring centrally secured to a suitable support and consisting of a central horizontal portion and substantially vertically disposed arms, the oppositely inclined bars normally converging toward their inner ends and hinged together at that point, and a vertically disposed coiled spring interposed between the central portion of the transverse spring and the inner ends of said bars and connected with those parts, substantially as described. 2nd. In a device of the class described, the combination of a substantially semi-elliptic leaf spring centrally secured to a suitable support and consisting of a horizontal portion and substantially vertically disposed curved arms adapted to be spread or forced outward, the oppositely inclined bars hinged at points intermediate of their ends to the arms of the spring, and a coiled spring connecting the inner ends of the arms with the central portion of the said spring, substantially as described. 3rd. In a device of the class described, the combination of a substantially semi-elliptic leaf spring having a horizontal portion and provided with curved sides, oppositely inclined bars hinged at their inner ends and similarly connected at points intermediate of their ends to the terminals of the leaf spring, stirrups arranged at the outer ends of the inclined bars, a shackle

embracing the inner ends of the bars and connected with the pintle or pivot thereof, and a coiled spring secured to the shackle and connected with the horizontal portion of the last spring, and interposed between the latter and the inclined bars, substantially as described.

No. 56,188. Sash Fastener. (Arrête-croisée.)

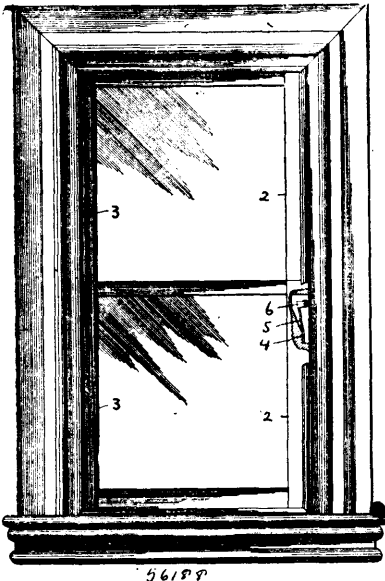

Winfield Scott Pettit, Hamonton, David Reed Pettit, Haleyville, and Edwin Devaul Sutton, Mauricetown, all of New Jersey, U.S.A., 8th June, 1897; 6 years. (Filed 8th May, 1897.)

Claim.—1st. A sash holder comprising flat springs secured to the outer edges of the side rails, and friction rollers carried at the outer or free end of the springs, substantially as shown and for the purpose set forth. 2nd. A sash holder comprising flat springs secured to the outer edges of the side rails of the sash so that their free ends will project outward therefrom, and rollers supported in frames which are swivelled to the outer ends of the springs, substantially as shown and for the purpose set forth. 3rd. In a sash holder, the combination with the side rails having recesses in their outer ends, the bottom of said recesses being inclined downward from one end to the other, of flat springs secured at one end in the shallow end of the recesses and curved to project beyond the sash, roller frames pivoted to the free ends of the flat springs and presenting ears which are pierced transversely, and rollers located in said frames, substantially as shown and for the purpose set forth.

No. 56,189. Dumping Car. (Char à bascule.)

(*Char à bascule.*)

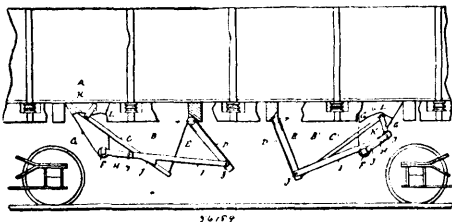

George H. Dunham, New York, State of New York, assignee of William McMahon, Rathway, New Jersey, all in the U.S.A., 8th June, 1897; 6 years. (Filed 13th May, 1897.)

Claim.—1st. The combination with a hopper, having a door or gate hung so as to approach the perpendicular, of a lever attached to said door and a crank for operating the same, and a locking device for locking said lever and crank in the closed position, substantially as set forth. 2nd. The combination, with a hopper and its door or gate, of mechanism located outside of the car body, comprising a lever and its operating crank, a shaft upon which said crank is carried, and a shoulder upon said lever located so as to abut against said shaft, substantially as set forth. 3rd. The combination, with a hopper and its door or gate, of mechanism located outside of the car body comprising a lever and its operating crank, a shaft upon which said crank is carried, a shoulder upon said lever located so as to abut against said shaft, and a locking device, substantially as set forth.

No. 56,190. Bicycle Support.

(*Support de bicycles.*)

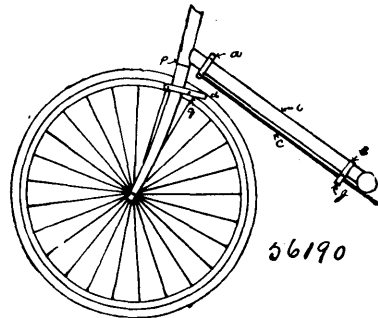

George William Hall, Brantford, Ontario, Canada, 8th June, 1897; 6 years. (Filed 22nd April, 1897.)

Claim.—A rest or brace attached to and carried on the frames of bicycles, with a lock for securing bicycles when not in use, substantially as set forth.

No. 56,191. Ball Bearing. (Coussinet à roulettes.)

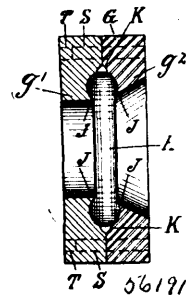

Mitchell T. Buchanan, Ingersoll, Ontario, Canada, 9th June, 1897; 6 years. (Filed 13th May, 1897.)

Claim.—1st. A ball bearing consisting of a ball case G, formed in two portions g^1, g^2 , in the adjacent faces of which a ball recess H, is formed, and provided with flanges J, and the balls I, substantially as and for the purpose set forth. 2nd. A ball bearing consisting of a ball case G, formed in two portions, g^1, g^2 , in the adjacent faces of which a ball recess H, is formed, and in one portion, a socket T, is formed, and to the other a pin S, is secured, and which ball case is provided with the flanges J, and the balls I, substantially as and for the purpose set forth. 3rd. In a ball bearing, a ball case G, in which is formed an inner groove K, to catch the dust and grit, substantially as and for the purpose set forth. 4th. In a ball bearing, a ball case G, in which is formed the ball recess H, and the inner groove K, to catch the dust and grit, substantially as and for the purpose set forth. 5th. A ball case G, formed in two portions, g^1, g^2 , in the adjacent faces of which a ball recess H, is formed and provided with the flanges J, and the balls I, in combination with the bearing cone B, substantially as and for the purpose set forth. 6th. A ball case G, formed in two portions, g^1, g^2 , in the adjacent faces of which a ball recess H, is formed, and in one portion, a socket T, is formed, and to the other a pin S, is secured, and which ball case is provided with the flanges J, and the balls I, in combination with the bearing cone B, substantially as and for the purpose set forth. 7th. A ball case G, formed in two portions, g^1, g^2 , in the adjacent faces of which a ball recess H, and inner groove K, is formed, and in one portion, a socket T, is formed, and to the other a pin S, is secured, and which ball case is provided with the flanges J, and the balls I, in combination with the bearing cone B, substantially as and for the purpose set forth. 8th. The ball cases G, G, each formed in two portions, g^1, g^2 , in the adjacent faces of which portions, a ball recess H, is formed and provided with the flanges J, and the balls I, in combination with the bearing cones B, B, spindle A, hub E, and axle nut D, substantially as and for the purpose set forth. 9th. The ball cases G, G, each formed in two portions, g^1, g^2 , in the adjacent faces of which portions, a ball recess H, and inner groove K, is formed, and provided with the flanges J, and the balls I, in combination with the bearing cones B, B, spindle A, hub E, bolts L, and axle nut D, substantially as and for the purpose set forth.

No. 56,192. Hand Rest for Bicycle Handle Bars.

(*Appui-mains pour manches de bicyclette.*)

Alexander William Biddle, Philadelphia, Pennsylvania, U.S.A., 9th June, 1897; 6 years. (Filed 3rd May, 1897.)

Claim.—1st. In combination with a bicycle handle bar, two broad slightly convex upper-surfaced hand rests conforming substantially

in form and extent to the open palms of the hands of the rider, substantially as and for the purpose specified. 2nd. In combination

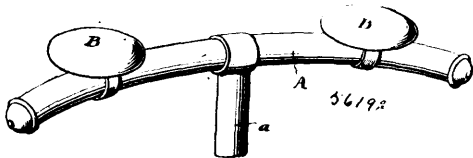

with a bicycle handle bar, two broad slightly convex upper-surfaced hand rests conforming substantially in form and extent to the open palms of the hands of the rider, and means for attaching said hand rests to said handle bar, substantially as and for the purpose specified. 3rd. In combination with a bicycle handle bar, two broad slightly convex upper-surfaced hand rests conforming substantially in form and extent to the open palms of the hands of the rider, and means applied to said hand rests for permitting of their independent adjustment with respect to said handle bar, substantially as and for the purpose specified.

No. 56,193. Propelling Mechanism for Cycles.
(*Mécanisme de propulsion pour cyclettes.*)

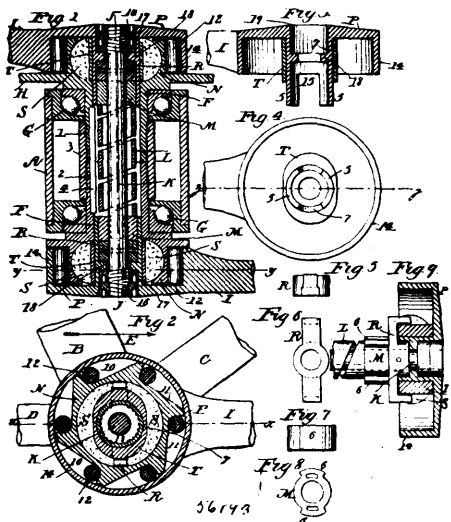

Gerard Beekman, New York, State of New York, U.S.A., 9th June, 1897; 6 years. (Filed 10th May, 1897.)

Claim.—1st. In a cycle, the combination with a rotary driven element, of two rotary pedal cranks flexibly connected in diametrically opposite relation to each other upon their axis of rotation and having their pivot of flexure on said axis, and clutch mechanism operated by the flexure of said cranks whereby to engage with said driven element. 2nd. In a cycle, the combination with a rotary driven element, of two rotary pedal cranks flexibly connected in diametrically opposite relation to each other upon their axis of rotation, torsional elastic means located on said axis connecting said cranks and tending to support them in said relation, and clutch mechanism operated by the flexure of said cranks whereby to engage with said driven element. 3rd. In a cycle, the combination with a rotary driven element, two rotary pedal cranks flexibly connected in diametrically opposite relation to each other upon their axis of rotation and having their pivot of flexure on said axis, of a clutch mechanism consisting in diametrically movable parts engaging with said driven element, and cam formations connected to said cranks and upon their axis acting on said diametrically movable parts so as to press them against said driven element by the motion of flexure of said cranks. 4th. In a cycle, the combination with a rotary driven element, of two rotary pedal cranks flexibly connected in diametrically opposite relation to each other upon their axis of rotation and having their pivot of flexure on said axis, each said crank provided with two independent clutch mechanisms; one clutch positively engaging with said driven element by the initial forward propelling rotation of a crank irrespective of its relative flexure to the other crank, and the other clutch frictionally and controllably engaging with said driven element by the retardation or backward rotation of said cranks and according to the relative flexure thereof produced or initiated by simultaneously opposing pressures of the feet of the rider on the respective crank pedals.

No. 56,194. Bicycle. (Bicycle.)

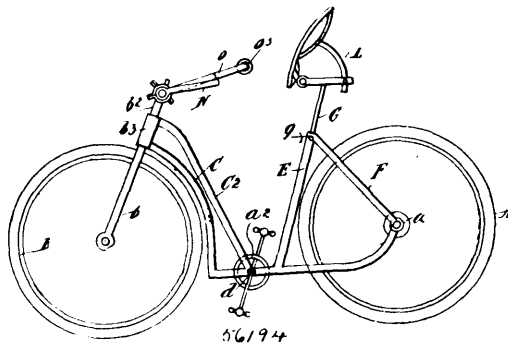

Joel Mix Gilbert, Clinton, Connecticut, U.S.A., 9th June, 1897; 6 years. (Filed 10th May, 1897.)

Claim.—1st. The combination with the frame of a bicycle or similar vehicle, of a guiding mechanism which consists of a cross-bar rigidly secured to a vertical rod which is adjustably connected with the forward fork of the machine, said cross-bar being provided with a backwardly-directed yoke which is adapted to support a handle bar which is provided with curved spring arms which are connected with the ends of the cross-bar, and which rest upon backwardly-directed yoke, substantially as shown and described. 2nd. The combination with the frame of a bicycle or similar vehicle, of a guiding mechanism which consists of a cross-bar rigidly secured to a vertical rod which is adjustably connected with the forward fork of the machine, said cross-bar being provided with a backwardly-directed yoke which is adapted to support a handle bar which is provided with curved spring arms which are connected with the ends of the cross-bars and which rests upon said backwardly-directed yoke, the arms of said handle bar being connected with clamps or bands which are mounted on the ends of the cross-bar, and the ends of said cross-bar being also provided with jaws between which said clamps or bands are mounted, said jaws being connected by cross-heads which limit the movement of the handle bar, substantially as shown and described. 3rd. The combination with the frame of a bicycle or similar vehicle, of a guiding mechanism which consists of a cross-bar rigidly secured to a vertical rod which is adjustably connected with the forward fork of a machine, said cross-bar being provided with a backwardly-directed yoke which is adapted to support a handle bar which is provided with curved spring arms, which are connected with the ends of the cross-bar, and which rest upon said backwardly-directed yoke, the arms of said handle bar being connected with clamps or bands which are mounted on the ends of the cross-bar, and the end of said cross-bar being also provided with jaws between which said clamps or bands are mounted, said jaws being connected by cross-heads which limit the movement of the handle bar, and each of said clamps or bands being provided with springs, one end of which is secured thereto, and the other rigidly connected with one of said jaws or with the cross-bar, substantially as shown and described. 4th. The combination with the bicycle or similar vehicle, of a steering or guiding mechanism, consisting of a cross-bar rigidly secured to the forward vertically-adjustable rod of the frame, said cross-bar being provided with a backwardly-directed yoke, and a handle bar which is adapted to rest thereon, said handle bar being provided with spring arms which extend across said yoke and which are connected with said yoke, being provided with rings or clamps which are provided with projections or locking devices, which are adapted to engage with said spring arms and from which said spring arms are adapted to be disconnected, as and for the purpose set forth, substantially as shown and described.

No. 56,195. Brake for Velocipedes. (Frein de velocipèdes.)

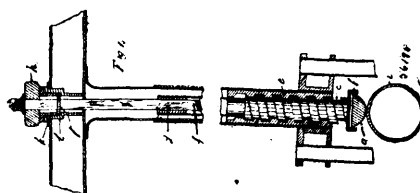

George Frederick Cadden, Coventry, Warwick, England, 9th June, 1897; 6 years. (Filed 8th May, 1897.)

Claim.—In brakes for velocipedes, a hollow screwed tube working in a socket carrying a movable brake surface, a rod of suitable section engaging in said hollow tube through the medium of a socket; a thumb piece or wheel for rotating said rod so that the brake may be applied to the surface of tire of wheel and shoulder upon said rod in order that the same may be retained in position

between the bearing and the screwed cap formed upon the hollow tube carrying the forks or handle bar, said hollow tube carrying the forks inclosing the rod and screwed hollow tube aforesaid.

No. 56,196. Bicycle. (Bicycle.)

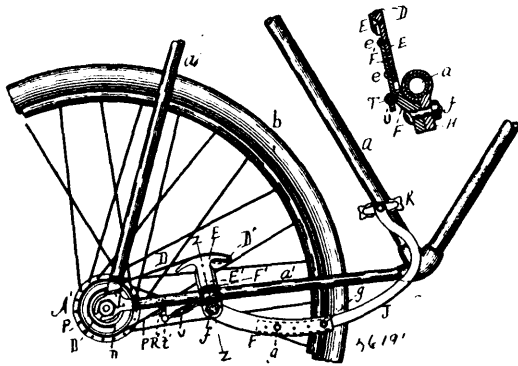

John Albert Anderson, Wakefield, Mass., U.S.A., 9th June, 1897; 6 years. (Filed 4th May, 1897.)

Claim.—1st. In a bicycle of the character described, in combination a drum enclosing the mechanism for imparting motion to the wheel; a band-brake disposed around said drum; a lever actuated by the pedal and pivotally secured to the frame of the machine, a driving connection intermediate of and connecting said lever and drum, and a brake-rod connected at one end with the band-brake and at the other end by means of a slotted connection with the pedal-lever, whereby a lengthened stroke of said lever will apply the brake, substantially as described. 2nd. In a bicycle of the character described, in combination, the frame, driving-shaft, hub provided with the flange A^1 and drum A^{11} , the clutching mechanism adapted to engage said drum, the band-brake P disposed around the drum, the swinging segment E provided with the shank E^1 , the pedal lever $F F^1$ pivotally secured to the frame and supporting said segment and shank, the brake-rod connected at one end with the ends of the band-brake and slotted to the other end, and a pin or bolt extending from the portion F^1 of said lever into said slot, substantially as set forth. 3rd. In a bicycle of the character described, in combination the frame, driving-shaft, hub provided with the flange A^1 and drum A^{11} , the clutching mechanism adapted to engage said drum, the band-brake P disposed around the drum, the swinging segment E provided with the shank E^1 , the pedal lever $F F^1$ pivotally secured to the frame and supporting said segment and shank, the bell crank $R R^1$ pivotally secured to the frame of the machine and having its arms pivotally connected with the opposite ends of the band-brake, and a brake-rod secured at one end to one arm of the bell-crank and at the other end by means of a slotted connection with the pedal lever, substantially as described.

No. 56,197. Seat Support for Bicycles.

(Support de sieges pour bicycles.)

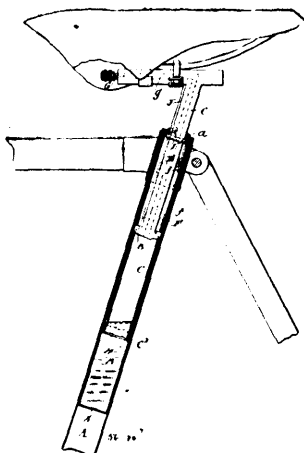

Edward Castildine Martin, Melbourne, Victoria, Australia, 9th June, 1897; 6 years. (Filed 8th April, 1897.)

Claim.—1st. A pneumatic seat-support consisting of a cylinder such as B , in combination with a hollow plunger such as C , fitted at its lower end with a hydraulic packing ring (such as c^1), working

in oil or other liquid in the bottom of said cylinder and carrying the saddle or seat at its upper end, substantially as and for the purposes herein described. 2nd. In a pneumatic seat-support, an inner tubular liner or cylinder such as B , fitting into the hollow back-stay of the frame of a bicycle in combination with a hollow plunger and saddle-pillar carrying the saddle or seat substantially as and for the purposes herein described. 3rd. In a pneumatic seat-support, an inner tubular liner such as B , fitting into the hollow back-stay of the frame of a bicycle, in combination with a hollow plunger and saddle-pillar provided with means such for instance as the nipple G , whereby one end of a length of rubber tube can be connected to it whilst the other end of said tube can be connected to the ordinary inlet valve or valves of the pneumatic tires of the vehicle-wheel, substantially as and for the purposes herein described.

No. 56,198. Bicycle Brake. (Frein de bicycle.)

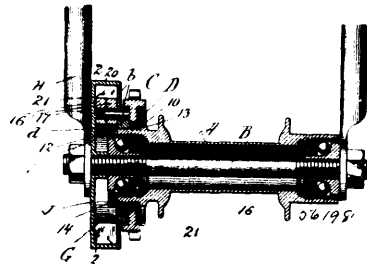

Nathan Edward Martin, Greenfield, Mass., U.S.A., 9th June, 1897; 6 years. (Filed 7th May, 1897.)

Claim.—1st. In a brake for a bicycle of the character described, the combination with the wheel-hub having a flange or disc thereon provided with the slots f, f , of the two brake members G, G , affixed or anchored to the disc at a common point and having inward projections at points between their anchorage and their free ends, the sprocket-wheel loosely mounted on the hub and having the lugs g, g , with the eccentric outer surfaces which protrude through and beyond said disc slots and engage said inward projections of the brake members, and the disc having a fixed support and provided with the annular flange, which surrounds the brake members, substantially as described. 2nd. In a brake for a bicycle of the character described, the combination with the wheel-hub having a flange or disc thereon provided with the slots f, f , of the brake members G, G , affixed or anchored to the disc at a common point, having the inward projections at points between their anchorage and free ends, which are adjustable radially, the sprocket-wheel loosely mounted on the hub and having the lugs g, g , with the eccentric outer surfaces which protrude through and beyond said disc slots and engage said adjustable projections of the brake members, and the disc having a fixed support, and provided with the annular flange, which surrounds the brake members, substantially as described. 3rd. In a brake for a bicycle, the combination with the wheel-hub having the flange or plate fixed thereon, of the sprocket-wheel mounted loose about said hub for an independent rotational movement relative thereto, one of these said parts being slotted and the other having a lug with an eccentric surface protruding through and beyond and movable along the slot, a frictional device mounted on one of said parts and having an inwardly-projecting member which is adjustable and in bearing engagement on said lug, and the fixed disc, and having the flange surrounding the friction device, for the purpose set forth. 4th. In a brake for a bicycle, the combination with the wheel-hub having the flange or disc fixed thereon provided with the slots f, f , of the brake members G, G , each having the inwardly-extending member 16 at one end and having inwardly-projecting members at points between its free end and said member 16, the stud uniting said member 16 to the disc, the sprocket-wheel loosely mounted about the hub and having the lugs g, g , with the eccentric outer surfaces protruding through said slots and in engagement with said inward projections of the brake members, and the disc J having the flange 20, all substantially as described. 5th. In a brake for bicycles, in combination, the wheel-hub having its end portion externally screw-threaded, the sprocket-wheel fitted to turn about said hub and having the projections g, g , which are provided with eccentric outer surfaces, the annular disc or plate b internally screw-threaded and provided with the eccentric arc slots f, f , said plate having a screw engagement on the hub with its face adjacent the side of the sprocket-wheel, the lugs of the latter protruding through and beyond said slots, the brake members G, G , affixed to the plate b and having the opposing inward extensions in bearing engagement on the eccentric surfaces of said sprocket-wheel lugs, detachable means for locking said plate upon the hub, and the disc J mounted on a fixed support, and having the annular flange which encloses brake members and closely overlies the edge of said plate b , substantially as described. 6th. In a brake for bicycles in combination, the wheel-hub having its end portion externally screw-threaded and provided with the shoulder 13, the flanged plate D on the hub against said shoulder, the sprocket wheel fitted to turn on said flanged plate and having the projections g, g , which are pro-

vided with eccentric outer surfaces, the annular plate *b* internally screw-threaded and provided with the concentric arc slots *f, f*, said plate screwing on the hub and having its face adjacent the sprocket-wheel, said lugs of the latter protruding through and beyond said slots, brake members *G, G*, both affixed or anchored to the plate at a common point and having the opposing inward extensions in bearing engagement on the eccentric surfaces of said sprocket-wheel lugs, the nut *d* screwing on the end of the hub against said plate *b*, and the disc *J* mounted on a fixed support and having the annular flange which encloses brake members and overlies the edge of the said hub plate *b*, all substantially as shown and described. 7th. In a brake mechanism, the combination with the hub, the sprocket-wheel, mounted thereon as described, having lugs *g* with eccentric surfaces, slotted plate *b* on the hub, the brake members *G, G*, each having inward lugs *16*, and end shoulder *21*, said shoulders being in abutment, a stud uniting each lug to the plate and the fixed flanged disc as shown. 8th. In a brake for a bicycle of the character described, the combination with the wheel-hub having a flange or disc thereon provided with the slots *f, f*, of the brake members *G, G*, affixed or anchored to the disc at a point common to both and having at points between its free ends and anchorage the screw-threaded sockets, the screw-plugs engaged in said sockets and inwardly-projected, the sprocket-wheel loosely mounted on the hub and having the lugs *g, g*, with the eccentric outer surfaces which protrude through and beyond said slots and engage said inwardly-projecting screw-plugs, and the disc *J* having a fixed support and provided with the annular flange, which surrounds the members *G*, substantially as described.

No. 56,199. Handle for Velocipedes.
(*Manches de velocipedes.*)

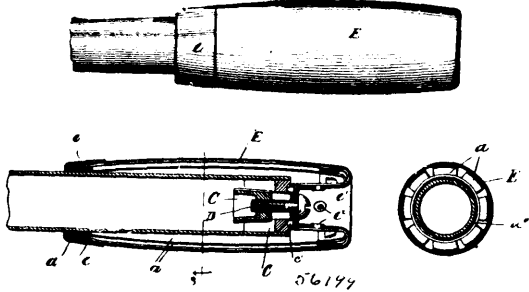

William John Grotenhuis and Henry Turner Sidway, both of Chicago, Illinois, U.S.A., 9th June, 1897; 6 years. (Filed 7th May, 1897.)

Claim.—1st. In a handle for velocipedes, the combination of an elastic metallic core formed of a series of independent longitudinal strips secured rigidly together at one end and flexibly at the other end, and a covering of fibrous material for inclosing and protecting the same, substantially as described. 2nd. In a handle bar for velocipedes, the combination of a core portion formed of a series of metallic strips independently and longitudinally arranged and secured together by a ring at one end and flexibly to each other by means of a cup-shaped portion at the other end, substantially as described. 3rd. In a handle bar for velocipedes, the combination of an elastic core formed of a series of metal strips longitudinally arranged, one end of which is cup-shaped and provided with an integral securing disc, and a covering of flexible or yielding material having perforations therein, substantially as described. 4th. In a handle bar for velocipedes, the combination of an elastic core formed of a series of metallic strips longitudinally arranged, a ring for rigidly securing the ends of one portion of the longitudinal strips together, a cup-shaped disc flexibly securing the other ends of the metallic strips together, an expanding cylindrical block adapted to be inserted into the handle bar and provided with one or more indentations, projections on the cup-shaped disc adapted to enter the indentations on the block, and means for securing the cup-shaped disc to the block to expand the same and hold the parts in operative position, substantially as described. 5th. In a handle bar for velocipedes, the combination of an elastic core formed of a series of metal strips longitudinally arranged and secured rigidly together at one end by means of a securing ring and provided with bayonet-shaped free ends, a cup-shaped end portion having a series of strips formed integrally with a base portion, the free ends of such strips having indentations, perforations or openings, adapted to receive the bayonet-shaped ends of the metallic strips and flexibly secure the parts together, substantially as described.

No. 56,200. Flexible Coupling for Conduits.
(*Joint flexibles pour conduits.*)

Henry Knight Austin, Reading, Mass., U.S.A., 9th June, 1897; 6 years. (Filed 5th April, 1897.)

Claim.—1st. An elastic coupling of the character specified, having distensible automatically-contracting end portions, which are internally enlarged at points near their ends. 2nd. An elastic coupling

of the character specified, having distensible automatically-contracting end portions, and an intermediate external finger-rest or shoulder.

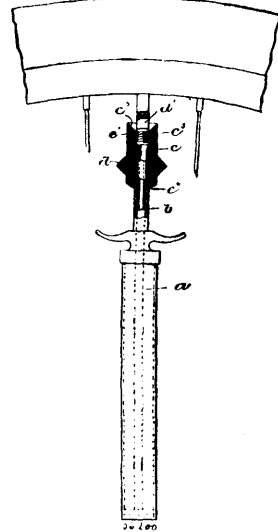

3rd. An elastic coupling of the character specified, having distensible automatically-contracting end portions, and an end recess or guide. 4th. An elastic coupling of the character specified, comprising distensible elastic end portions or mouths having sufficient inherent elasticity or contractile force to grasp the terminal portions of an air-valve and an air-pump, and automatically form and maintain air-tight joints therewith.

No. 56,201. Bicycle Gearing. (*Engrenage de bicycles.*)

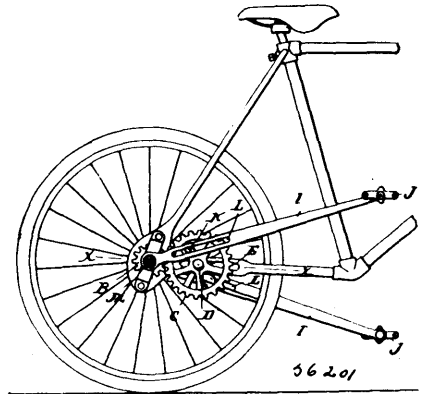

Frederick John Repp, Steelton, Pennsylvania, U.S.A. 9th June, 1897; 6 years. (Filed 24th April, 1897.)

Claim.—1st. In combination with bicycle pinions, secured upon the hub of the drive wheel, gears meshing with said pinions, levers fulcrumed upon the axial line of said hub, said levers having slots formed therein, crank-pins carried by the gears projecting within the slots, as specified. 2nd. In combination with a bicycle and the drive wheel thereof, to pinions secured to the hub of said wheel, two gears adapted to mesh with said pinions, said gears being detachably secured to the frame of the machine, levers fulcrumed concentric with a hub having slots formed therein, crank-pins projecting from the gear wheels within said slots and pedals carried by said levers, substantially as and for the purpose set forth. 3rd. The herein described combination with a bicycle, of a pair of pinions rigidly mounted upon the hub of the drive wheel, gear wheels detachably secured to the frame of the machine, and adapted to mesh with the pinions, crank-pins projecting from said wheels, levers fulcrumed concentric with the drive-wheel, said levers having slots formed therein for the reception of the crank-pins, and pedals carried upon the outer ends of the levers, substantially as and for the purpose set forth.

No. 56,202. Process of Covering Bicycle Frames.
(*Procédé pour couvrir les cadres de bicycles.*)

A. G. Spalding & Bros., Jersey City, New Jersey, assignee of James Ellsworth Robinson, Chicago, Illinois, all in the U.S.A., 9th June, 1897; 6 years. (Filed 15th April, 1897.)

Claim.—1st. The process of covering the hollow joints and tubing of bicycle frames, which consists in applying celluloid or other like

material thereto in the semi-liquid or plastic state while the metal is heated from within, permitting the same to harden, and repeating

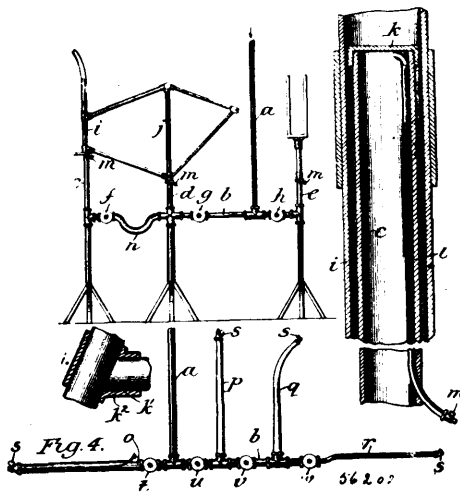

the operation until the desired thickness of coating is attained. 2nd. The process of covering bicycle frames or other similar structures with celluloid or other like material, which consists in heating the frame from within, applying coats of plastic celluloid or other like material thereto, and permitting them to dry successively, then applying a further coat and smoothing it by means of a soft fabric while yet plastic. 3rd. The process of covering bicycle frames with celluloid or other like material, which consists in first heating the joints and tubing from within, applying coats of liquid celluloid or other like material to the joints and permitting them to dry successively until a sufficient body is attained, holding sheet celluloid or other like material upon suitable mandrels to fit the respective tubes and forks, and placing said molded structures upon the heated frame and cementing them thereto.

No. 56,203. Bicycle Gearing. (Engrenage de bicycles.)

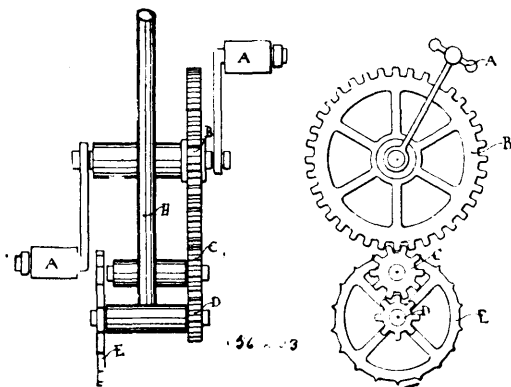

Carl C. Schmidt, Saint John, New Brunswick, Canada, 9th June, 1897; 6 years. (Filed 23rd April, 1897.)

Claim.—A combination of three wheels, cogged or toothed, fitting into one another, the largest one to be turned with the ordinary pedal attachment, and the smallest one D being on the same axle as the ordinary wheel E, and by the revolution of the said wheel D the wheel E is made to revolve.

No. 56,204. Bicycle Handle Bar.

(Attache de frein pour bicycles.)

Thomas H. Burton, Chicago, Illinois, U.S.A., 9th June, 1897; 6 years. (Filed 8th March, 1897.)

Claim.—1st. In a bicycle, the combination with a steering head post having a tubular bearing thereon, a handle-bar mounted to rock in said bearing and a locking mechanism comprising locking teeth arranged concentric to the handle-bar and a sliding wedge or plate having its ends projected through apertures in the bar and adapted to engage with said teeth, the apertures of the bar being out of alignment with the inter-spaces of the locking teeth, substantially as described. 2nd. In a bicycle, the combination with a steering-head post having a tubular bearing mounted thereon, a handle-bar mounted to rock in said bearing, a locking mechanism comprising teeth formed on the tubular bearing and a wedge

mounted and adapted to slide in slots in the handle-bar and having its ends projecting to engage said teeth, a thumb-piece mounted

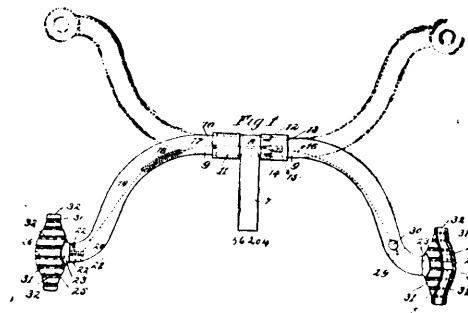

No. 56,205. Bicycle Support. (Support de bicycles.)

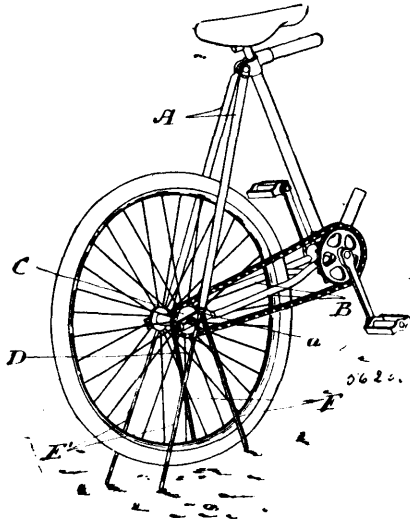

William Preston, assignee of George Kennie, both of Stratford, Ontario, Canada, 9th June, 1897; 6 years. (Filed 14th April, 1897.)

Claim.—1st. In a bicycle, a hollow rear fork member, in combination with a support slidable therein, means for holding the support concealed within the rear fork member and for holding it extended, substantially as and for the purpose specified. 2nd. In a bicycle, a hollow rear fork member, in combination with a support slidable therein and divided a short distance from its upper end, one of the parts being hinged to the main portion of the support, and means for holding the support concealed within the said rear fork member, substantially as and for the purpose specified. 3rd. In a bicycle, a hollow rear fork member, in combination with a support slidable therein, and divided a short distance from its upper end, both of the parts being hinged to the main portion of the support; and means for holding the support concealed within its said rear fork member, substantially as and for the purpose specified. 4th. In a bicycle, a hollow rear fork member, in combination with a support slidable therein, and divided a short distance from its upper end, both of the parts being hinged to the main portion of the support; means for holding the support concealed within its said rear fork member, and a spring between the parts of the support tending to spread them, substantially as and for the purpose specified. 5th. In a bicycle, a hollow rear fork member having a sleeve, with a bayonet slot cut therein, brazed within its lower end, in combination with a support slidable therein, and having a pin thereon near its lower end adapted to engage with the said slot, and means for holding the support extended, substantially as and for the purpose specified. 6th. In a bicycle, a hollow rear fork member having a sleeve, with a bayonet slot cut therein, brazed within its lower end, in combination with a support slidable therein, and divided a short distance from its upper end, one of the parts being hinged to the main portion of the support; and a pin connected to one of the parts near its lower end and adapted to engage with the said slot, substantially as and for the purpose specified. 7th. In a bicycle, a hollow rear fork member having a sleeve, with a bayonet slot cut therein, brazed within its lower end, in combination with a support slidable therein; and divided a short distance from its upper end, one of the parts being hinged to the main portion of the support; a pin connected to one of the parts near its lower end and adapted to engage with the said slot; the lower end of the divided portion of the support being flush with the lower end of the fork member when the pin is so engaged, and provided with a projection, substantially as and for the purpose specified. 8th. In a bicycle, a hollow rear fork member having a sleeve, with a bayonet slot cut therein, brazed within its lower end, in combination with a tubular support slidable therein, and divided a short distance from its upper end, one of the parts being hinged to the main portion of the support, a pin connected to one of the parts near its lower end and adapted to engage with the said slot, the lower ends of the divided parts of the support being closed and provided with hollow projections having rubber pads secured therein, substantially as and for the purpose specified. 9th. In a bicycle, a hollow rear fork member, having a sleeve with a bayonet slot cut therein, brazed within its lower end, in combination with a tubular support slidable therein, and divided a short distance from its upper end, both of the parts being hinged to the main portion of the support, a pin connected to one of the parts near its lower end and adapted to engage with the said slot, the lower ends of the divided parts of the support being closed and provided with hollow projections having rubber pads secured therein, and a spring located between the parts of the supports tending to spread them, substantially as and for the purpose specified.

No. 56,206. Bicycle Support. (Support de bicycles.)

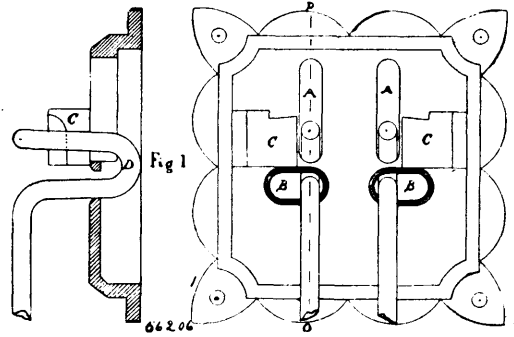

Frederick L. Thurston, Hamilton, Ontario, Canada, 9th June, 1897; 6 years. (Filed 15th April, 1897.)

Claim.—1st. This arrangement of the slots in the casting of a bicycle holding frame. 2nd. The form of the hooks D on the ends of a bicycle holder wire. 3rd. The combination of the slots A and B, in the casting, and form of the hooks D on the wire of a bicycle holder, by which it can be thrown in and out of gear, all as described and set forth in the drawing and specification.

No. 56,207. Sprocket Wheel. (Roue dentée.)

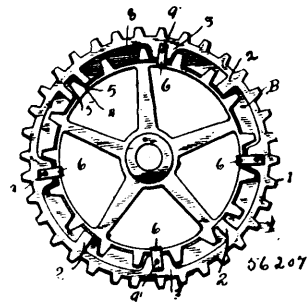

John B. Young, Chicago, Illinois, U.S.A., 9th June, 1897; 6 years. (Filed 22nd September, 1896.)

Claim.—1st. The combination with a sprocket-wheel, of a supplemental sprocket-rim therefor, and a clamping device for holding the sprocket wheel and rim relatively fixed, substantially as described and shown. 2nd. The combination with a sprocket-wheel, of a supplemental sprocket-rim having lugs projecting between the teeth and the sprocket wheel, and a clamping device for holding the sprocket-wheel and rim relatively fixed, substantially as described and shown. 3rd. The combination with a sprocket-wheel, of a supplemental sprocket-rim having arms straddling the rim of the sprocket-wheel, substantially as described and shown. 4th. The combination with the sprocket-wheel, of a supplemental sprocket-rim, clamping plates straddling the rim of the sprocket-wheel, and a fastening device connecting said clamping-plates and the supplemental rim, substantially as described and shown. 5th. The combination with the sprocket-wheel, of a supplemental sprocket-rim having inwardly projecting bifurcated lugs resting between the teeth of the sprocket-wheel, clamping plates located on both sides of the supplemental rim, and straddling the rim of the sprocket-wheel, and screws passing through the clamping plates and bifurcations in the lugs, substantially as described and shown. 6th. The combination with the sprocket-wheel, of a supplemental sprocket-rim having radial arms projecting between the teeth of the sprocket-wheel and provided with a slot, clamping plates located on opposite sides of the supplemental-rim and straddling the rim of the sprocket-wheel, said clamping plates being provided with lugs adapted for the reception of the radial arms, and screws passing through the clamping-plates and slots, substantially as described and shown. 7th. The combination with a sprocket-wheel, of a supplemental sprocket-rim having a bifurcated inwardly projecting lug straddling a tooth of the sprocket-wheel, and adapted to prevent relative rotation of the sprocket-wheel and rim, and a clamping device for preventing lateral displacement of the rim, substantially as described and shown. 8th. The combination of a sprocket-wheel, and a supplemental sprocket-rim provided with a series of lugs projecting between the teeth of the sprocket-wheel, and also having bifurcated lugs straddling the rim of the sprocket-wheel and supplemental rim together, substantially as described and shown.

No. 56,208. Device for inflating Pneumatic Tires.

(Appareil pour gonfler les bandages pneumatiques.)

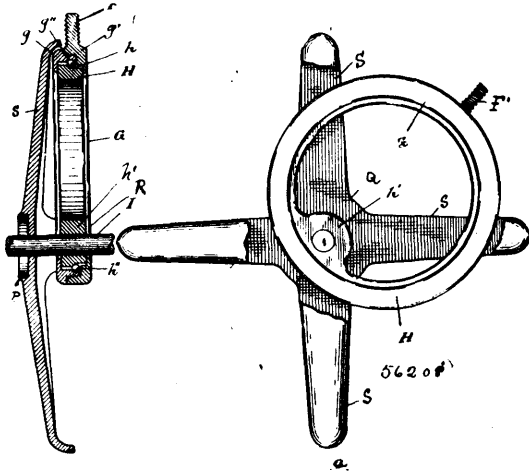

James Riggs, Toronto, Ontario, Canada, 9th June, 1897; 6 years. (Filed 2nd January, 1897.)

Claim.—1st. In a device for inflating pneumatic tired wheels, the combination of an air pump connected to the valve of the tire, a stationary eccentric disc mounted on the wheel axle, and an eccentric strap surrounding the disc, revolving with the rim of the wheel, and operating the air pump, substantially as specified. 2nd. In a device for inflating pneumatic tired wheels, the combination of an air pump connected to the valve of the tire, a stationary eccentric disc mounted on the wheel axle, an eccentric strap surrounding the disc, revolving with the rim of the wheel, and operating the air pump, and a safety valve for the tire, substantially as specified. 3rd. In a device for inflating pneumatic tired wheels, an air pump connected to the valve of the tire, a stationary eccentric disc mounted on the wheel axle, an eccentric strap surrounding the disc, revolving with the rim of the wheel and operating the air pump, in combination with the wheel hub, composed of two independent sections, and a brace to hold the sections asunder consisting of two hubs mounted on the axle, one on each side of the eccentric disc, and a plurality of arms radiating from each hub, the outer ends of the arms of one hub uniting with the outer ends of the arms of the other hub, and each brace hub fitted to receive the end of the adjacent wheel hub section, substantially as specified. 4th. In a device for inflating pneumatic tired wheels, an air pump connected to the valve of the tire, a stationary eccentric disc mounted on the wheel axle, an eccentric strap surrounding the disc, revolving with the rim of the wheel and operating the air pump, in combination with the wheel hub, composed of two independent sections, and a brace to hold the sections asunder consisting of two hubs mounted on the axle, one on each side of the eccentric disc, and a plurality of arms radiating from each hub, the outer ends of the arms of one hub uniting with the outer ends of the arms of the other hub, and each brace hub fitted to receive the end of the adjacent wheel hub section, and a safety valve for the tire, substantially as specified. 5th. In a device for inflating pneumatic tired wheels, the combination of the pneumatic tire, an air injecting apparatus operated during the revolution of the wheel for inflating the tire, and a safety valve for the tire consisting of a hollow stem connected to the tire, a longitudinally movable pin in the bore of the stem having a flange and a washer serving as a valve to close the end of the bore, an adjustable cap inclosing the end of the stem and pin, pressing against the cap and flange, substantially as specified. 6th. In a device for inflating pneumatic tired wheels, a wheel hub composed of two independent sections in combination with a brace to hold the hub sections asunder, consisting of two hubs mounted on the wheel axle, and a plurality of arms radiating from each hub, the outer ends of the arms of one hub uniting with the outer ends of the arms of the other hub, each brace hub fitted to receive the end of the adjacent wheel hub section, substantially as specified.

No. 56,209. Rubber Tire. (Bandage en caoutchouc.)

Frederick William Huestis, Boston, Mass., U.S.A., 9th June, 1897; 6 years. (Filed 14th April, 1897.)

Claim.—1st. A tire for vehicles composed of two tubes of rubber, an inner tube and an outer tube, and a wrapping of fibrous rubber-coated threads interposed between the tubes, said threads being wound spirally about the inner tube, substantially as specified. 2nd. A tire for pneumatic use, consisting of an inner tube, a wrapping of fibrous threads having a homogeneous rubber coating and separately applied about the inner tube, and an outer tube to inclose the fibrous wrapping, the whole to be subsequently vulcanized, substantially as explained. 3rd. A tire for vehicles, composed of an inner tube of rubber, an outer tube of rubber, two layers of threads interposed between the tubes, and a layer or coating of rubber inter-

posed between the layers of threads. 4th. A tire for vehicles consisting of an outer covering of rubber, and one or more layers of

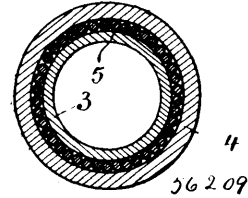

threads saturated in rubber cement and laid contiguously. 5th. A tire for vehicles consisting of an outer covering of rubber, a layer of contiguous rubber-saturated threads, wound spirally, and a second layer of contiguous rubber coated threads laid at an angle to the threads of the first layer. 6th. A tire for vehicles consisting of an outer covering of rubber, one or more layers of contiguous rubber-saturated threads wound spirally, and an inner layer of flexible woven material upon which the threads were wound.

No. 56,210. Bicycle Support. (Support de bicycles.)

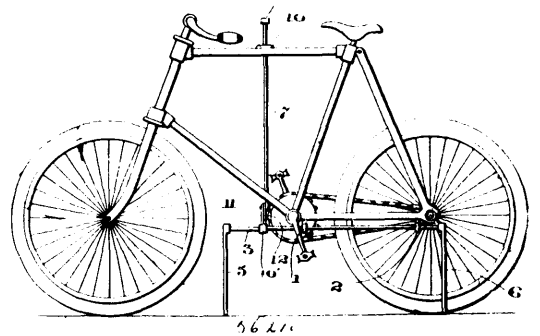

Joseph Henry Iler, Troy, New York, U.S.A., 9th June, 1897; 6 years. (Filed 15th April, 1897.)

Claim.—1st. In a bicycle support, the combination with pivoted legs, of a shifting rod, connections between said rod and the legs and means for locking the shifting rod. 2nd. In a bicycle support, the combination with pivoted legs, of a shifting rod or bar, rocker arms connected to the legs and links connecting the rocker arms with the shifting bar. 3rd. In a bicycle support, the combination with bearings connected with the members of the rear fork, of shafts journalled in said bearings, front and rear legs carried by each shaft, a reciprocable shifting bar or rod having a handle, rocker arms connected to the shafts, links pivotally connecting the rocker arms with the shifting bar, and a locking catch adapted to engage with the shifting bar and the latter.

No. 56,211. Cyclometer. (Cyclomètre.)

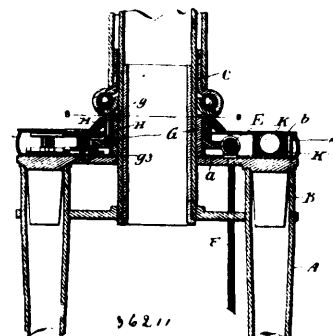

Charles Shochon Labofish and Charles Robert Harris, both of Williamsport, Pennsylvania, U.S.A., 10th June, 1897; 6 years. (Filed 2nd March, 1897.)

Claim.—1st. The combination with a bicycle-frame, of a cyclometer consisting of an indicating device which surrounds and is adapted to rotate on a part of the frame, and means for rotating this indicating device operated by a wheel of a machine. 2nd. The combination with a bicycle-frame, of a two-part cyclometer, one part of which surrounds and rotates upon the steering-head, and means operated by a wheel of the machine for turning this part of the cyclometer. 3rd. The combination with a bicycle-frame, of a two-part cyclometer, one part surrounding the steering-head and

actuating the other part. 4th. The combination with a bicycle-frame, of a two-part cyclometer, one part surrounding the steering-head, and the other secured to the fork-crown and gearing connecting the two parts. 5th. The combination with a bicycle-frame, of a two-part cyclometer, one part secured on the fork-crown at one side of the steering-head and the other part surrounding the steering-head and a spirit-level located on the other side of the steering-head. 6th. The combination with a bicycle-frame, of a metal case adapted to rest on the fork-crown and provided with a central opening for the passage of the steering-head, a cyclometer located within said case at one side of the steering-head and a spirit-level located therein on the opposite side, substantially as set forth. 7th. The combination with a bicycle-frame, of a two-part cyclometer, one part resting on the fork-crown and the other surrounding the steering-head, a worm-wheel and gearing for actuating the section of the cyclometer surrounding the steering-head, and gearing connecting the two sections of the cyclometer.

No. 56,212. Pedal Rubber.

(Caoutchouc pour pedales.)

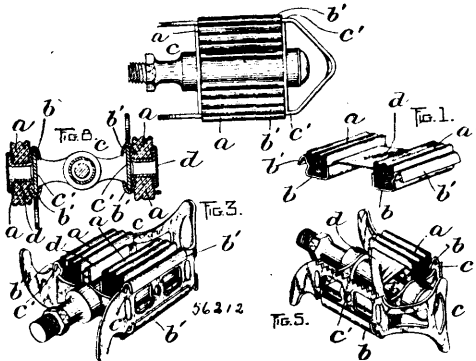

The Robert Malcolm Co., San Francisco, assignee of Frank Judson Willard, Sacramento, both in California, U.S.A., 10th June, 1897; 6 years. (Filed 17th April, 1897.)

Claim.—1st. An attachment for pedals, consisting of a pair of elastic tread-blocks, and a pair of holders exterior of and adapted to clamp the bases of said blocks, each of said holders having hooks or a hooked flange adapted to engage the edges of the pedal, and a spring connecting the holders, whereby they can be stretched to fit the pedals and be held there by the tension of the spring. 2nd. An attachment for pedals, consisting of a pair of elastic tread-blocks, and a pair of holders clamping exteriorly the bases of the blocks and having hooked flanges projecting from one side and adapted to engage the edges of the pedal, and an elastic piece having its ends connected with the inner sides of the holders and having its intermediate portion adapted to be passed under the shaft of the pedal. 3rd. A rubber attachment for pedals, consisting of a pair of holders, each holder being provided with a laterally projecting hooked flange on one edge adapting it to be adjusted to the edges of the pedal, elastic blocks having their bases fitted into and clamped by the holder, and a spring-piece connecting the sides of the holders opposite to those upon which the flanges are formed, whereby the frames may be readily fitted to the pedal and held in place. 4th. An attachment for bicycle-pedals, comprising two elastic or frictional tread-blocks, sheet-metal holders confining said blocks and provided with hooked coupling-flanges adapted to engage the tread-bars or plates of the pedal, and an elastic web connecting said blocks and holders and adapted to co-operate with said hooks in holding the blocks in their operative positions.

No. 56,213. Pneumatic Tire.

(Bandage pneumatique.)

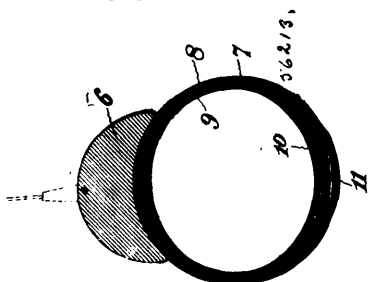

The Para Rubber and Manufacturing Co., assignee of David Wagner Deshler, both of Williamsport, Pennsylvania, U.S.A., 10th June, 1897; 6 years. (Filed 1st May, 1897.)

Claim.—A pneumatic tire composed of an outer tubular covering, an inclosed inflation tube and a flexible and impenetrable protective

strip secured between the inflation tube and the tread portion of the outer tubular covering but separate from the latter, the said protective strip being composed of cemented layers of pliable light-weight woven fabric united throughout in a compact, tough and puncture-proof body, substantially as described.

No. 56,214. Seat for Bicycles. (Siège de bicycles.)

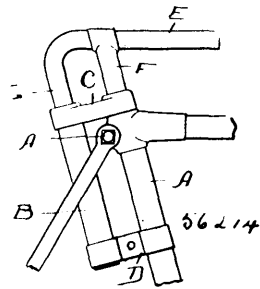

Benjamin F. Field, Chicago, Illinois, U.S.A., 10th June, 1897; 6 years. (Filed 20th April, 1897.)

Claim.—1st. The combination with a bicycle saddle provided with two parallel depending posts of the frame tube adapted to receive one of the posts, and a guide tube arranged parallel with the frame tube and adapted to receive the other post, substantially as specified. 2nd. The combination with a bicycle saddle provided with two parallel depending posts, of the frame tube adapted to receive one of the posts, and a guide tube arranged parallel with the frame tube and adapted to receive the other post, and springs inserted in said tubes and supporting the posts, substantially as specified. 3rd. The combination with a bicycle saddle provided with two parallel depending posts F and G, of the frame tube receiving one of said posts, a guide tube arranged parallel with the frame tube and receiving the other post, springs inserted in said tubes and supporting the posts, and means for limiting the upward movement of the seat, substantially as specified. 4th. The combination with a bicycle saddle provided with two parallel depending posts F and G, of the frame tube receiving one of said posts, a guide tube arranged parallel with the frame tube and attached thereto, and receiving the other post, and springs inserted in said tubes and supporting the posts, substantially as specified.

No. 56,215. Support for Bicycles.

(Support pour bicycles.)

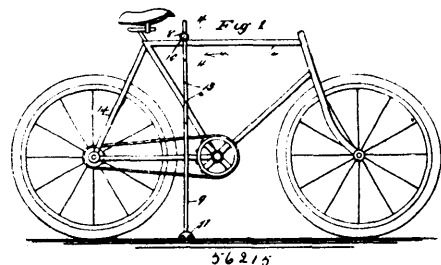

Martha Gubbard Mason, San Diego, California, U.S.A., 10th June, 1897; 6 years. (Filed 15th April, 1897.)

Claim.—1st. A support for bicycles, consisting of a bar or rod which is adapted to be suspended from the frame of the vehicle, said bar or rod being provided at each end with hubs or heads through which are passed rods, the lower ends of which are provided with feet, said rods being vertically adjustable in said hubs or heads, substantially as shown and described. 2nd. The combination with the frame of a bicycle, or a support suspended therefrom, said support consisting of a cross rod which is provided at each end with heads or hubs, and with upright rods which are passed therethrough, and adjustable therein, said rods being provided at their lower ends with feet which are adapted to rest upon the ground, substantially as shown and described.

No. 56,216. Bicycle Lantern. (Lanterne de bicycles.)

John Charles Miller, Waterbury, Connecticut, U.S.A., 10th June, 1897; 6 years. (Filed 17th April, 1897.)

Claim.—1st. In a bicycle lantern, the combination, with the fount thereof, of a flanged suspension collar secured to the top of the said fount, and a conical ring located within the lower portion of the said collar, and acting as a funnel and as a fender. 2nd. In a bicycle lantern, the combination with a fount, provided upon its top with a flanged suspension collar, of a lantern body provided with a depending fount-supporting collar formed with a lip into

which the forward portion of the flange of the said suspension collar is hooked, a fount catch-plate secured to the said suspension

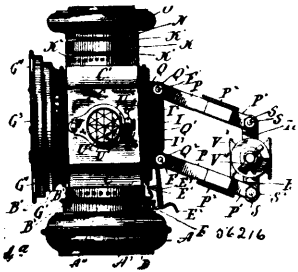

collar of the fount, and a suspended, swinging fount-catch connected with the body of the lantern and depending in position to engage with the said fount-catch plate. 3rd. In a bicycle lantern, the combination with the main or body portion thereof, of a removable fount, two suspension frames connected with the lantern for affording a yielding support for the same, and a swinging, spring-actuated fount-catch suspended from the pivot of the lower suspension frame of the lantern. 4th. In a bicycle lantern, the combination, with the main or body portion thereof, of a removable fount, an upper and a lower suspension frame connected with the lantern for affording a yielding support for the same, a swinging spring-actuated fount-catch, comprising a locking-finger, a stop-finger, a finger piece and a plate, the upper end of which is adapted to be suspended from the pivot of the lower suspension-frame; and a spring engaging with the said plate and coiled upon the said pivot. 5th. In a bicycle lantern, the combination with the body thereof, of a conical lens-holder applied thereto, and a removable lens-holding ring adapted to be secured to the forward edge of the lens-holder and to engage with the lens. 6th. In a bicycle lantern, the combination with the body thereof, of a conical lens-holder secured to the front of the said body, and a removable lens-holding ring adapted to engage with the lens, and furnished with segmental locking flanges for connecting it with the forward edge of the lens-holder. 7th. A reflector for a lantern, comprising a conical reflector-ring, a reflector-cup and two arms connecting the ring and cup and adapting them to be handled as one piece. 8th. A reflector, comprising a conical reflector-ring, a reflector-cup and two longitudinally bowed spring-arms permanently connected with the ring at their forward ends, and adapted to have the cup removably connected with their rear ends. 9th. In a bicycle lantern, the combination with the body thereof, of a conical lens-holder secured thereto, a removable lens-retaining ring connected with the forward edge of the lens-holder, a reflector comprising a reflector-cup, two arms connected with the same, and a reflector ring which is also connected with the said arms, and partly located within the lens-holder; and a lens which is placed against the forward edge of the reflector-ring, and exerts an inward thrust upon the same so to hold it and therefore the cup in place. 10th. In a bicycle lantern, the combination with the body thereof, of a conical lens-holder, a removable lens-holding ring adapted to be connected with the forward edge of the said holder, and a reflector comprising a reflector cup, two arms and a reflector-ring, which is formed with a draft-opening and with a locating-finger, which co-acts with the lens-holder for insuring the right location of the reflector within the body of the lantern. 11th. In a bicycle lantern, the combination with the body thereof, of a cap-supporting collar secured to the top of the said body, a cap connected with the upper end of said collar and a conical current-breaker located centrally within the upper end of the sleeve. 12th. In a bicycle lantern, a conical current-breaker comprising a cone, arms extending outwardly and downwardly therefrom, and a ring in which the lower ends of the said arms terminate. 13th. In a bicycle lantern, the combination with the body thereof, of a cap-supporting sleeve permanently secured thereto and formed with air-inlet openings, and a fender permanently secured within the said collar and guarding the said air-inlet openings. 14th. In a bicycle lantern, the combination with the body thereof, of a cap-supporting collar permanently secured thereto and formed with air-inlet openings, a fender guarding the said openings, located permanently within the said collar, a removable current-breaker set into the upper end of the collar and a cap-supporting ring set over the upper end of the said collar and removably connected therewith and containing air-egress openings, and a cap connected with the said ring. 15th. In a bicycle lantern, the combination with the body thereof, of two suspension frames pivotally connected at the forward ends with the back of the said body, and a yoke connecting the rear ends of the said frames and comprising one or more corrugated discs. 16th. In a bicycle lantern, the combination with the body thereof, of two suspension frames pivotally secured thereto, a yoke connecting the rear ends of the said frames and comprising one or more corrugated discs, and a clip having one or more corrugated faces to co-act with those of the yoke. 17th. A fork-clip for securing bicycle lanterns to the forks of bicycles, the said clip comprising two pivotal fork-clasping arms, and a tubular box, the outer end of which is corrugated.

No. 56,217. Spring Wheels for Bicycles and other Vehicles. (Roue à ressort pour bicycles, etc.)

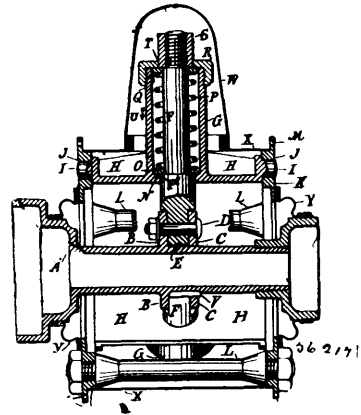

William George Gibbs, Geelong, New South Wales, Australia, 10th June, 1897; 6 years. (Filed 17th April, 1897.)

Claim.—1st. In combination, the inner hub having the flanges, the spring pins connected to the said flanges, the outer hub rings fastened a fixed distance apart, and the cylinders enclosing the bodies of said spring pins and having trunnions journalled in the outer hub rings, substantially as set forth. 2nd. In combination, the inner hub having the flanges, the spring pins connected to the said flanges, each spring pin having a shoulder F^1 , with a body portion enclosed by a spiral spring P within a cylinder G , and an end portion having a nut or enlargement S thereon with washers O, Q , between the ends of said spring and the parts F^1 and S respectively, substantially as set forth. 3rd. The cylinders G , each having trunnions journalled in outer hub rings, and having a shoulder N and cap R having a hole T , in combination with spiral spring P and washers O, Q , between said spiral springs and the cylinder ends, substantially as set forth. 4th. The combination of the inner hub, the flanges, the spring pins connected to the flanges and each having a shoulder F^1 and a nut or enlargement S , the cylinders each having a shoulder N and a cap R , and internal washers O, Q , and spring P , and having trunnions H , with ends I journalled in outer hub rings, and the bolts L connecting the said hub rings at a fixed distance apart, substantially as set forth.

No. 56,218. Bicycle Boot. (Chaussure pour bicycles.)

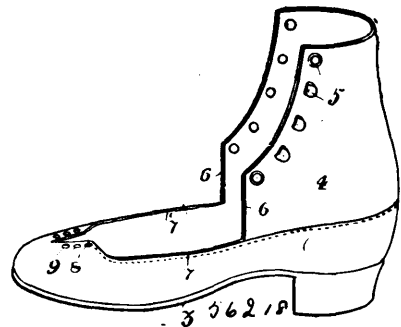

Antoine Laroque, Montreal, Quebec, Canada, 10th June, 1897; 6 years. (Filed 17th May, 1897.)

Claim.—1st. A boot adapted to support the ankle of the wearer, and having that portion of the upper over the instep entirely cut out or dispensed with, the said part of the upper embracing the ankle being joined to the toe portion by the low sides, substantially as set forth and for the purposes described. 2nd. A bicycling boot, consisting of the upper embracing the ankle, lace holes 9 in said toe portion, and elastic band or strap 10 , substantially as described and set forth.

No. 56,219. Ball Bearing for Bicycles, etc.

(Cousinet à roulettes, etc.)

Alfred Marceau, Brooklyn, New York, U.S.A., 10th June, 1897; 6 years. (Filed 22nd April, 1897.)

Claim.—1st. In a ball bearing for vehicles, the combination, with a spindle or axle and its hub having screw-threaded ends, of ball-supporting elements in each end, consisting essentially, of a ball race cap having a rearwardly extending flange adapted to be screwed into the screw-threaded end of the hub and having a ball-retaining disc or flange at the front of said cap, and means connected with said cap, at or near the end of the screw-threaded flange, for form

ing the ball-race, and balls therein, substantially as and for the purpose set forth. 2nd. In a ball bearing for vehicles, the combination,

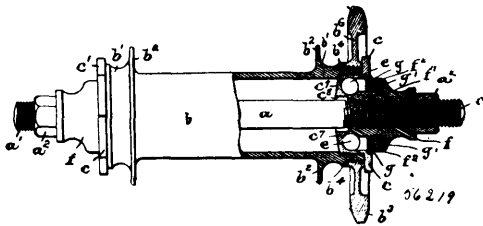

with a cylindrical spindle or axle, and its hub having screw-threaded ends, of ball-supporting elements in each end, consisting essentially, of a ball-race cap *c*, having a rearwardly extending flange *c*³, adapted to be screwed into the screw-threaded end of the hub, and having a flange *c*⁴ forming a central opening in the face of said cup, and a cup-shaped ball-holder in said cap, removably held therein by friction, and being adapted to be removed from the hub with said ball-race cap, in its operative holding or retaining position in said cap and balls therein, substantially as and for the purposes set forth. 3rd. The combination, with a ball-race cap *c* having on its face an annular flange or rib *c*⁵ and a flange *c*⁶, of a cone *f* having an annular flange *f*² into which said flange *c*⁶ is fitted, an inwardly extending and annular flange *c*³ on said cap, and a cup-shaped ball-holder *d* removably held in position in said flange *c*³, and balls therein, substantially as and for the purposes set forth. 4th. In a ball bearing for vehicles, the combination, with a cylindrical spindle of axle, and its hubs having screw-threaded ends, of ball-supporting elements in each end, comprising therein, a ball-race cup *c* having a rearwardly extending flange *c*³ adapted to be screwed into the screw-threaded end of the hub, a flange *c*⁴ forming a central opening *c*² in the face of the cap, an annular flange or rib *c*⁵ and a flange *c*⁶ on the face of said cap, a cone *f* having an annular flange *f*² into which said flange *c*⁶ is fitted and a cup-shaped ball-holder *d* in said cap, removably held therein by friction, and being adapted to be removed from the hub with the ball-race cap, and balls therein, substantially as and for the purposes set forth. 5th. A sprocket wheel for a bicycle bearing, having a web-portion *b*⁸, out of alignment with the central vertical plane of the wheel, and provided with a screw-threaded hub *b*⁷, substantially as and for the purposes set forth.

No. 56,220. Fire Escape. (Sauveteur d'incendie.)

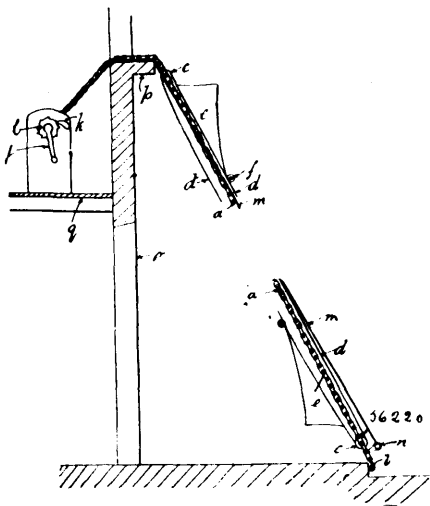

Charles William George Aldridge and William Charles Clark, both of London, England, 10th June, 1897; 6 years. (Filed 17th April, 1897.)

Claim.—1st. The combined construction and arrangement of the various parts, substantially as described and shown. 2nd. In fire escapes, a flexible chain or support which carries a movable continuous band having pockets thereon for the reception of individuals, safety bolts or catches for arresting the movement of the band, guide ropes or cards for enabling an individual to control his descent, hooks or the like for enabling one end of the fire escape to be attached to the curb or edge of a pavement or such suitable support, a winch for rolling up and holding the fire escape when not in use, a cabinet or covering for said winch. 3rd. In fire escapes, a continuous band having pockets for the reception of individuals and carried upon a support through the medium of rollers or the like.

No. 56,221. Method of Forging Solid Metal Car-Wheels. (Méthode de forger les roues de chars.)

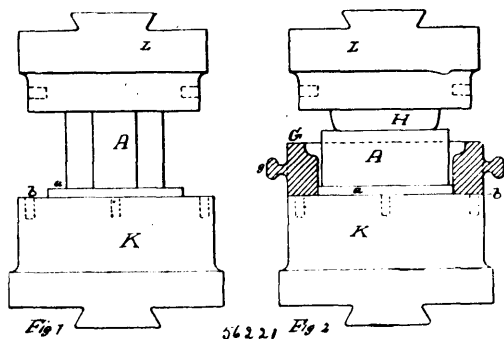

Samuel H. Ralston, Morrilstown, Pennsylvania, U.S.A., 10th June, 1897; 6 years. (Filed 13th January, 1897.)

Claim.—1st. The method of producing car-wheels from suitable blooms, ingots, or billets, consisting essentially, first, in forging a rudimentary flange on a wheel blank, and second, shaping and finishing by forging the wheel blank causing the metal to flow radially outwards from the hub to the tread and flange under an operative force, substantially as set forth. 2nd. The method of producing car-wheels from suitable blooms, ingots, or billets, consisting essentially, first, in forging a flange on a wheel blank, by means of blows or pressure at right angles to the side of the blank, and second, shaping and finishing by forging the wheel blank causing the metal to flow radially outwards from the hub to the tread and flange under an operative force.

No. 56,222. Foot Vise. (Etau à pieds.)

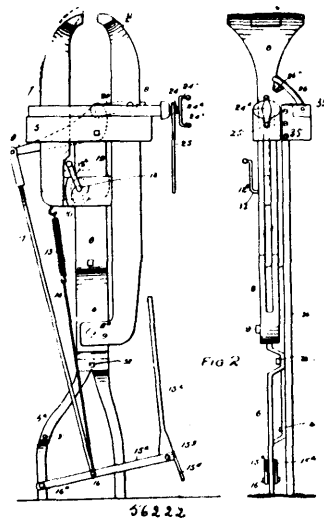

Edward B. Newman and Henry Cole, both of Denver, Colorado, U.S.A., 10th June, 1897; 6 years. (Filed 13th March, 1897.)

Claim.—1st. In a vise, the combination of the stationary frame, the pivoted jaws 7 and 8 surrounded by said frame, the foot-lever, the pitman connected with said lever, the bell-crank lever connected with the upper extremity of the pitman, the link connecting the jaw 8 with the bell-crank lever, a rod also connected with the foot-lever, and a coil-spring connecting the rod with the lower extremity of the jaw 7, and suitable means for adjusting the jaw 7 with reference to the jaw 8, substantially as described. 2nd. In a vise, the combination of a suitable frame, of the pivoted jaws 7 and 8 mounted on the frame, the foot-lever, the pitman connected with said lever, the bell-crank lever fulcrumed on the frame and connected with the pitman, the link connecting the pitman with the jaw 8, the rod also connected with the foot-lever, a coil-spring connecting the rod with the jaw 7, a yoke surrounding the jaws, and a screw engaging a threaded aperture formed in one end of the yoke and bearing against the stationary frame, substantially as described. 3rd. In a vise, the combination with a suitable frame, the pivoted jaws, and suitable means for adjusting and operating the jaws, of means for raising one of the jaws above the other, said means consisting of a crank-pin and a disc eccentrically mounted thereon and located in an aperture formed in the jaw, the pin being journaled in a suitable support independent of the jaw to be raised, as and for the purpose

set forth. 4th. In a vise, the combination with a suitable frame, the jaws 7 and 8, and suitable means for adjusting and operating the jaws, of means for raising one jaw above the other, said means consisting of a pin and a disc eccentrically mounted thereon and located in an aperture formed in the jaw, the pin being journaled independently of the jaw to be raised, and connected with the disc by a feather and spline, substantially as described. 5th. In a foot-vise, the combination with a suitable frame, the pivoted jaws 7 and 8, and means for adjusting the jaw 7, of an operating foot lever, and means for connecting the lever with the jaw 8, said lever being composed of two parts hinged together, and a yielding connection substantially as described, between the lever and a suitable support, whereby as the lever is released, the outer part thereof will rise and remain in an upright position, as and for the purpose set forth. 6th. In a vise, the combination with the frame, of the pivoted jaws 7 and 8, the operating foot-lever composed of two parts pivotally connected, a suitable connection between said foot-lever and the jaw 8, and a yielding connection, substantially as described, between said lever and the jaw 7, whereby as the lever is released, the outer part thereof will rise to an upright position, as and for the purpose set forth. 7th. In a vise, the combination with the frame, and the jaws 7 and 8, of a foot-lever composed of two parts pivotally connected, a suitable connection between said lever and the jaw 7, said connection consisting of a rod and a coil-spring, whereby as the lever is released, its outer part will rise to an upright position, as and for the purpose set forth. 8th. In a foot-vise, the combination of the pivoted jaws 7 and 8, the frame supporting the jaws, a foot-lever, a suitable connection between said lever and the jaw 6, and a lock comprising the arm pivoted on the frame and carrying a lug adapted to pass between the jaw 8 and the frame, as and for the purpose set forth. 9th. In a foot-vise, the combination of the pivoted jaws 7 and 8, the frame supporting the jaws, the operating foot-lever, a suitable connection between said lever and the jaw 8, and a movable locking-arm having a wedge-shaped projection adapted to pass between the jaw 6 and the frame, as and for the purpose set forth. 10th. In a vise, the combination with the supporting-frame, the pivoted jaws 7 and 8, and means for adjusting the jaw 7, comprising the yoke surrounding the jaws, the screw passing through a threaded aperture formed in the yoke, its inner extremity engaging the frame, said screw having a cross-head at its outer extremity, and projections or lugs formed on the cross-head, and a detachable arm having an aperture adapted to engage the projections on the cross-head substantially as described. 11th. In a vise, the combination with the supporting-frame, the pivoted jaws 7 and 8, means for adjusting the jaw 7, comprising a yoke surrounding the jaws and resting on the frame, a screw engaging a threaded aperture in the yoke, its inner extremity bearing against the frame, its outer extremity being provided with a cross-head having lugs or projections, a detachable lever-arm adapted to engage the lugs on the cross-head, an operating foot-lever, and a suitable connection between said lever and the jaw 8, substantially as described. 12th. In a foot-vise, the combination with the frame, the pivoted jaws 7 and 8, and suitable means for adjusting the jaw 7 with reference to the jaw 8, of a foot-lever composed of two parts pivotally connected, a connection with the jaw 7, comprising a rod and a spring, this connection being made between the pivoted joint and the fulcrum, and a connection with the jaw 8, comprising the rod, the bell-crank lever and the link, substantially as described.

No. 56,223. Manufacture of Textile Fabrics for Underclothing. (*Fabrication de tissus pour vêtements.*)

Carl Muhlinghaus, Lennep, Rhenish Prussia, assignee of Robert Thomalla, Berlin, both in Germany, 10th June, 1897; 6 years. (Filed 2nd November, 1895.)

Claim.—In making double stuffs for undershirts and the like the use of unprepared and raw material for the inner part still containing its natural and greasy matter and prepared material for the outer part, substantially as and for the purpose hereinbefore set forth.

No. 56,224. Sap Bucket. (*Seau à sève.*)

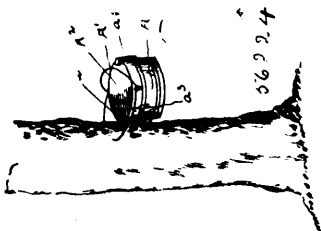

Jackson A. Taylor, James S. Parker and George T. Hays, all of Woodville, Alabama, U.S.A., 10th June, 1897; 6 years. (Filed 19th May, 1897.)

Claim.—1st. A bucket provided with a cover, backwardly and downwardly extending prongs near the bottom of the bucket, and

pivoted hooks attached to the upper end of said bucket. 2nd. A bucket provided with a cover having a stationary section and a hinged section, a sap-spoon extending from said stationary section, downwardly and backwardly projecting prongs near the bottom of said bucket, and pivoted hooks near the upper end of said bucket. 3rd. A bucket provided with downwardly and backwardly projecting prongs near its bottom, and pivoted arms at its upper end portion, said arms being provided with backwardly-bent end portions to form hooks.

No. 56,225. Pipe-Wrench. (*Clé à écrou pour tuyaux.*)

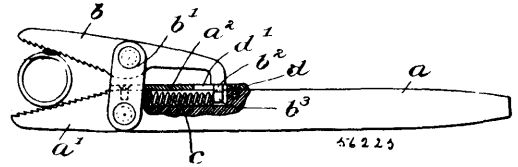

Samuel May, jr., Boston, assignee of Daniel Rupert Porter, Chelsea, both in Massachusetts, U.S.A., 10th June, 1897; 6 years. (Filed 22nd March, 1897.)

Claim.—1st. A pipe-wrench comprising in its construction a handle having a rigid jaw and a longitudinally extending recess back of the same, a jaw supported by links pivoted to it and to the handle, said jaw having a heel-piece engaging the longitudinal recess in the handle, a spring in said recess and bearing against the heel-piece of the jaw, and a slotted plate fastened over the recess. 2nd. A pipe-wrench comprising in its construction a handle having a rigid jaw, a movable jaw, links connecting the jaws and pivoted to each of them, and a spring exerting itself longitudinally of the jaws, and thereby tending to close them by moving the links, substantially as described.

No. 56,226. Spool Holder. (*Porte-bobines.*)

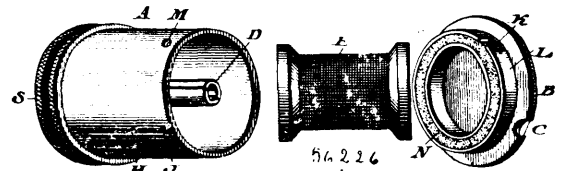

Abraham Moyer Yeakel and Mahlon Hunsicker Myers, both of Perkasie, Pennsylvania, U.S.A., 11th June, 1897; 6 years. (Filed 23rd March, 1897.)

Claim.—1st. A casing having a closed and an open end, and a longitudinally-extending slot with a widened end, a spool-holding spindle secured to said closed end, a cap for the open end of said casing, a cutter on said cap, and a spring on said spindle adapted to press the spool in the direction towards said cutter, the widened end of said slot being adjacent to said cutter. 2nd. A spool holder consisting of the casing A, having the longitudinally-extending slot H, with the widened end J in its side, the spindle D secured to the closed end of said casing, the cap B with the hollow flange L having a slot adapted to engage a pin on said casing, and packing in said flange L, forming a cushion. 3rd. A spool holder consisting of a casing, having a closed and an open end, and a longitudinally-extending slot with a widened end, a spindle secured to the closed end of said casing, a cap closing the open end of said casing and having a cutter on its rim adjacent to said widened end of the slot, said spindle projecting through said closed end and said cap having a boss thereon.

No. 56,227. Machine for Printing and Cutting Cards. (*Machine pour imprimer et couper les cartes.*)

Frank Richard Bischoff and Herman Spegel, both of New York, U.S.A., 11th June, 1897; 6 years. (Filed 24th March, 1897.)

Claim.—1st. In a machine for printing and cutting cards, the combination with a box or casing provided with a slot in the front thereof, and a removable top, of a roller mounted in supports connected with said top and adapted to receive a strip of paper, said top being also provided with a slot through which said strip of paper is passed, a shaft mounted transversely of the box or casing, and provided with a type plate cylinder, a type plate connected with said cylinder, a ratchet wheel connected with said shaft, a cutting blade pivotally supported above the slot in front of the casing, a lever pivotally connected with said cutting blade, and adapted to be operated by the shaft on which the type plate cylinder is mounted, a feed roller mounted below the shaft on which the type plate cylinder is mounted, an inking roller mounted adjacent to said type plate cylinder, and means for revolving the shaft on which the type plate cylinder is mounted, substantially as shown and described. 2nd. In a machine for printing and cutting cards the combination with a box or casing provided with a slot in the front thereof, and a removable top, of a roller mounted in supports connected with said top and

adapted to receive a strip of paper, said top being also provided with a slot through which said strip of paper is passed, a shaft

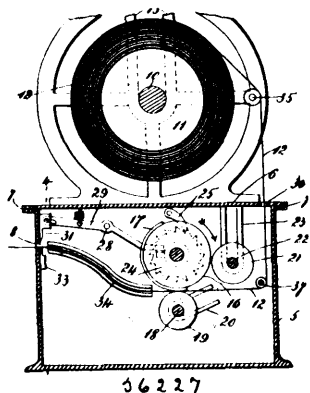

mounted transversely of the box or casing, and provided with a type plate cylinder, a type plate connected with said cylinder, a ratchet wheel connected with said shaft, a cutting blade pivotally supported above the slot in front of the casing, a lever pivotally connected with said cutting blade, and adapted to be operated by the shaft on which the type plate cylinder is mounted, a feed roller mounted below the shaft on which the type plate cylinder is mounted, an inking roller mounted adjacent to said type plate cylinder, and means for revolving the shaft on which the type plate cylinder is mounted, and a pivoted pawl which is adapted to operate in connection with said ratchet wheel, substantially as shown and described. 3rd. A card printing and cutting machine, comprising a box or casing which is provided with a removable top, said box or casing being also provided in the front thereof with a transverse slot below which is mounted a cutting blade, and said removable top being provided with supports for a paper roll, and with a transverse slot through which the paper is passed, and devices mounted in said box or casing, and adapted to feed the strip of paper therethrough, and through said slot in the front thereof, and means connected therewith for printing the cards and cutting the same, substantially as shown and described.

No. 56,228. Propeller. (Propulseur.)

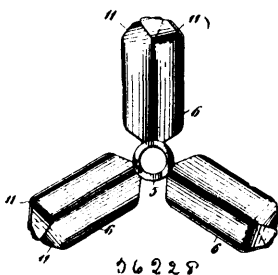

Thomas Washington Southington and James Tilley Mitchell, both of Locust Valley, New York, U.S.A., 11th June, 1897; 6 years. (Filed 26th March, 1897.)

Claim.—1st. A propeller provided with blades which project radially from the head thereof, and which are secured obliquely thereto, said blades being curved longitudinally as described, and being split at their ends, and the wings or parts thus formed being turned in opposite directions, substantially as shown and described. 2nd. A propeller provided with blades which project radially from the head thereof, and which are set obliquely to said head, said blades being bent centrally and longitudinally to form a forwardly directed portion, at each side of which they are segmental in form in cross-section, the edges thereof being directed forwardly, substantially as shown and described. 3rd. A propeller, the blades of which project radially from the head thereof, and are curved longitudinally so as to form a forwardly directed central portion, the sides of each blade adjacent to said central portion being segmental in form, in cross-section with the edges thereof directed forwardly, and the outer end of each blade being also split for a portion of its length, and the separate parts thus formed being turned in opposite directions, substantially as shown and described. 4th. A propeller, provided with blades which project radially from the head thereof, and which are secured obliquely thereto, said blades being curved longitudinally as shown and described.

No. 56,229. Spreading-Cart. (Charette d'étendage.)

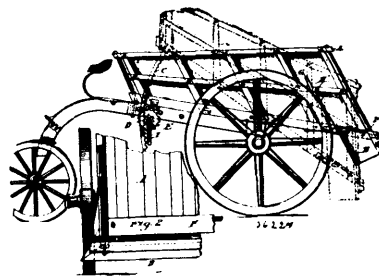

Roy Stone, Washington, Columbia, and The American Road Machine Company, Kennett Square, Pennsylvania, both in the U.S.A., 11th June, 1897; 6 years. (Filed 31st March, 1897.)

Claim.—1st. The combination in a spreading-cart or wagon, of a cart-body having a horizontal aperture, a controlling gate therefor, and a discharge-mouth, the low-end of which has a lip adapted for levelling the discharged material, said mouth being adjustable in relation to the ground, for the purpose set forth. 2nd. A spreading-cart or wagon provided with a flaring discharge-mouth behind the wheels, the delivery opening thereof extending laterally beyond the wheel tread, for the purpose set forth. 3rd. In a spreading-cart or wagon, the combination of the tiltable cart-body, the discharge-mouth on the rear end of said body, the means for tilting said body to bring the discharge-mouth to substantially horizontal position, and mechanism for holding the body and its discharge-mouth rigid at the positions of adjustment, substantially as and for the purpose set forth.

No. 56,230. Thill Coupling. (Arçon de limonière.)

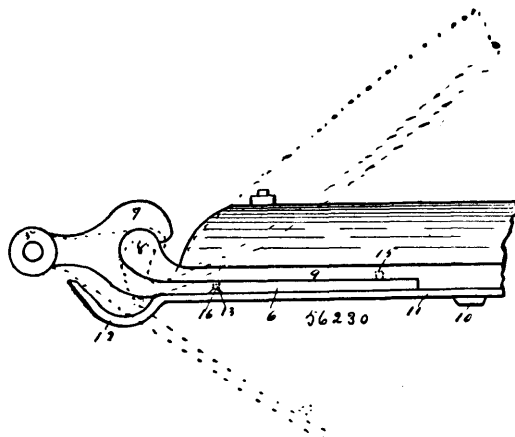

James Cavanagh, assignee of Nicholas Shults, both of Lake City, Michigan, U.S.A., 11th June, 1897; 6 years. (Filed 3rd May, 1897.)

Claim.—1st. A thill or pole coupling, comprising a pivoted thill-eye provided with its integral socket and attaching-bar, a thill-iron provided with the lug adapted for attachment in a detachable manner with the socket of the thill-eye, and a latch or the like for engagement with the attaching-bar to hold it in place substantially as set forth. 2nd. A thill or pole coupling, comprising a pivoted thill-eye provided with its integral socket and attaching-bar, said attaching-bar having a lug on the upper side, a thill-iron provided with a lug adapted for attaching in a detachable manner with the socket of the thill-eye, said thill-iron having a socket on the under side to receive the lug of the attaching-bar to keep it from displacement, and a spring latch adapted to swing over the attaching-bar to hold it in position, substantially as set forth. 3rd. A thill or pole coupling comprising a pivoted thill-eye provided with the integral socket and attaching-bar, a thill-iron provided with a lug adapted for detachable attachment with the socket of the thill-eye, a latch adapted to swing over the attaching-bar, to hold it in place, said latch and attaching-bar and the parts against which they rest being provided with interlocking lugs and sockets to hold the parts from lateral displacement, substantially as set forth.

No. 56,231. Ice Creeper. (Grappin.)

Honoré Prevost, James Luther Rankin and George A. Beaverly, all in Montreal, Quebec, Canada, 11th June, 1897; 6 years. (Filed 7th May, 1897.)

Claim.—1st. In an ice-creeper, a series of adjustable ice gripping projections adapted to be adjusted towards the centre of the tread of a boot or the like, means for adjusting and carrying said pro-

jections, and means for affixing said creeper to said tread. 2nd. In an ice creeper having ice gripping projections, a pair of adjustable

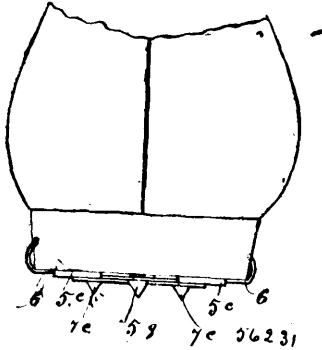

clamps, means for carrying and means for adjusting said clamps for the purpose set forth. 3rd. In an ice creeper, the combination of a slotted frame piece having a pair of guideways formed upon its upper side, said frame pieces being slotted longitudinally of said guideways, a pair of perforated clamps located in said guideways, an actuating plate fulcrumed upon the lower side of said frame piece, said actuating plate being slotted eccentrically thereof and transversely of the slots in said frame piece, a pair of studs having conical heads and diminished ends, the bodies of said studs passing upwardly freely through the slots in said actuating plate and frame piece and the diminished ends thereof taking through the perforations in the clamps to which said studs are rigidly connected by rivetting or flattening said diminished ends, for the purpose set forth. 4th. In an ice creeper, the combination of a frame piece in the form of a cross having its transverse arms slotted longitudinally and formed with a pair of guideways upon the upper side thereof, one end of said frame piece being semi-circular in form and provided on its edge with a series of downwardly projecting ratchet-teeth, a pair of perforated clamps located in said guideways, an actuating plate formed with a rapidly projecting arm having one edge upwardly off-set to engage said ratchet-teeth and fulcrumed upon the lower side of said frame piece, said actuating plate being slotted eccentrically thereof and transversely of the slots in said frame piece, a pair of studs having conical heads and diminished ends, the bodies of said studs passing upwardly freely through the slots in said actuating plate and frame piece, and the diminished ends thereof taking through the perforations in the clamps to which said studs are rigidly connected by rivetting or flattening said diminished ends, substantially as and for the purpose set forth. 5th. In an ice creeper, the combination of a frame piece in the form of a cross having its transverse arms slotted longitudinally and formed with a pair of guideways upon the upper sides thereof, one end of said frame piece being semi-circular in form and provided on its edge with a series of downwardly projecting ratchet-teeth, the other end of said frame piece being tapered and carrying a conical projection rigidly on the underside thereof, a pair of perforated clamps located in said guideways, an actuating plate formed with a radially projecting arm having one edge upwardly off-set to engage said ratchet-teeth, and fulcrumed upon the lower side of said frame piece, said actuating plate being slotted eccentrically thereof and transversely of the slots in said frame piece, a pair of studs having conical heads and diminished ends, the bodies of said studs passing upwardly freely through the slots in said actuating plate and frame piece, and the diminished ends thereof taking through the perforations in the clamps to which said studs are rigidly connected by rivetting or flattening said diminished ends, substantially as and for the purpose set forth. 6th. In an ice creeper, a pair of adjustable clamps, ice gripping projections carried by said clamps, means for carrying and means for adjusting said clamps, for the purpose set forth. 7th. In an ice creeper, the combination with the part-, a device comprising a portion adapted to unite said parts together and an ice gripping portion. 8th. In an ice creeper, the combination of perforated movable parts, a slotted stationary frame piece and slotted movable parts, devices adapted to unite said parts together and to present ice gripping portions, said devices consisting of studs having conical heads and diminished ends, the bodies of said studs passing upwardly freely through said slotted movable part and slotted frame piece, and the diminished ends taking through said perforated movable parts and adapted to be flattened down against said perforated parts, for the purpose set forth.

No. 56,232. Method of Constructing Fireproof Floors, Flats, Partitions and Walls. (Méthode de construire des planchers, etc., à l'épreuve du feu.)

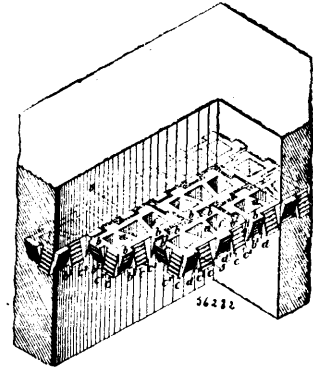

The Hanson Fire Proof Floor Syndicate Limited, assignee of John Treadway Hanson, both of London, England, 11th June, 1897; 6 years. (Filed 10th May, 1897.)

Claim.—1st. A floor, wall or the like composed of blocks having upon the sides and ends oppositely inclined projections *b, c*, so arranged that the inclines *b, b'* of one block are adjacent to or in contact with the inclines *c, c'* of adjacent blocks, substantially as described. 2nd. Blocks for the manufacture of fire-proof floors and the like constructed substantially in the manner hereinbefore described and illustrated in figures 1 to 3 of the accompanying drawings. 3rd. The manufacture or construction of fire-proof floor, (or wall) substantially in the manner hereinbefore described and illustrated in the accompanying drawing.

No. 56,233. Valve Gear. (Soupape.)

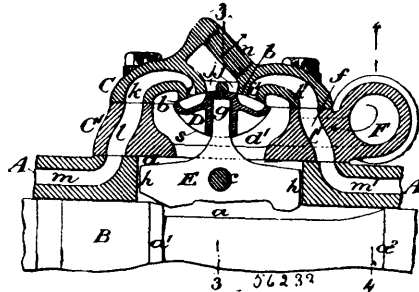

The Ingersoll-Sergeant Drill Company, assignees of Henry Clark Sergeant, both of Westfield, New Jersey, U.S.A., 11th June, 1897; 6 years. (Filed 11th May, 1897.)

Claim.—1st. The combination with an engine cylinder and a piston therein provided with tappet surface, of a valve-chest on the said cylinder containing a valve-seat of concave arc-formed longitudinal profile facing towards the cylinder, a valve having a corresponding convex arc-formed longitudinal profile facing away from the cylinder, and a three-armed oscillating tappet lever having its axis of oscillation coincident with the centre of the arc of the valve and seat, one arm of the said lever engaging with the valve at the back thereof and its other two arms constituting tappets to be acted upon by the said tappet surfaces, substantially as herein described.

No. 56,234. Door Latch. (Loquet de porte.)

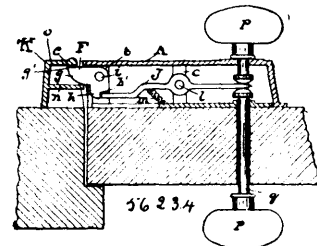

Charles Hall Ayars and Maurice Bertram Ayars, both of Salem, New Jersey, U.S.A., 11th June, 1897; 6 years. (Filed 17th May, 1897.)

Claim.—In a latch, a keeper having the ordinary flanged outer plate *o*, and separate trip-plate *n*, whose edge projects beyond the

edge of said outer flanged plate, combined with a latch-case having a single-pronged latch *F*, pivoted in the case and provided with an outer flat face *e*, and an opposite curved face *g*, which curve intersects the said flat face and forms a curved point end *g'*, the said flat face and point end always projecting exteriorly of the case-opening, so that upon closing the door said point end will pass the said outer flanged plate of the keeper and strike the said projecting trip-plate thereof, whereby the curved face will slide on the trip-plate and thereby the latch will be tilted to the locked position and wholly concealed in the keeper.

No. 56,235. Steam-boiler Furnace with Artificial Draft for Burning Coal Dust. (Chaudière à vapeur.)

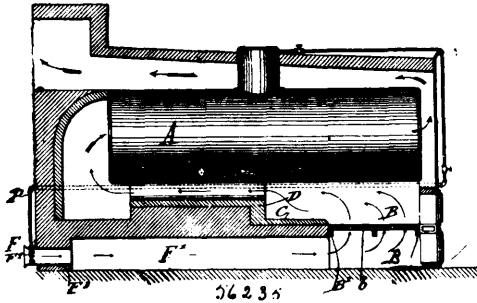

The Parsons Manufacturing Co., assignee of Henry E. Parsons, both of Brooklyn, New York, U.S.A., 11th June, 1897; 6 years. (Filed 17th May, 1897.)

Claim.—1st. The combination with a steam-boiler having a closed front wall, of grate-bars having conical openings, and a steam-blower for supplying artificial draft to the fuel on said grate-bars, substantially as set forth. 2nd. In a steam-boiler furnace, a storing platform arranged back of the grate and in front of the fire-bridge, substantially as set forth. 3rd. The combination with a steam-boiler, of grate-bars having conical tapering openings, a closed front wall for the steam-boiler, a steam-blower, a pipe connecting the steam-blower with the dome of the steam-boiler, and means for superheating the steam in its course to the steam-blower, substantially as set forth. 4th. In a steam-boiler furnace, a number of alternately arranged baffle-walls extending alternately from the side walls of the furnace in the channel back of the fire-bridge, substantially as set forth. 5th. A steam-blower for steam-boiler furnaces, consisting of an exterior casing, a nozzle-frame arranged in said casing and connected with the steam-supply pipe, the nozzle-frame being provided with radial arms having forwardly-projecting nipples with conical bases, cylindrical bosses in the rear walls of the radial arms, and air-tubes adjusted in said bosses and provided with conically tapering inner ends, substantially as set forth.

No. 56,236. Hay, Grain and Fodder Elevator. (Elevateur à grain, etc.)

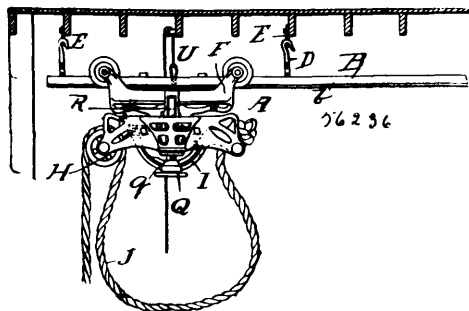

The Whitman & Barnes Manufacturing Co., Akron, Ohio, assignee of Manias George Grosscup, Chicago, Illinois, both in the U.S.A., 11th June, 1897; 18 years. (Filed 17th May, 1897.)

Claim.—1st. In a hay, grain or fodder elevator, a trolley carrying a lever to which the lifting cable is attached, an independently pivoted gripping dog to which said lever is loosely connected between the pivot and gripping face of said dog, and in proximity to another portion of the lifting cable which said dog is adapted to engage when actuated by said lever upon its release, and means for releasing said lever, for the purpose specified. 2nd. In a hay, grain or fodder elevator, in combination, a lever to which the lifting cable is attached, a separate dog loosely connected with said lever and adapted to engage another portion of the cable, means for holding said dog out of such engagement and means for allowing it to make such engagement at any desired point or elevation of the cable, for the purpose specified. 3rd. In a hay, grain or fodder elevator, in

combination, a travelling trolley, a lever pivoted therein and carrying one end of the lifting cable, said lever being connected to an independently pivoted dog adapted to contact with the lifting cable, the pivot of said dog being nearer the point of cable contact than is the pivot of said lever, means for holding said lever in an elevated position whereby the dog is out of engagement with the lever, and means for allowing it to descend and thereby cause the dog to engage the cable, for the purpose specified. 4th. In a hay, grain or fodder elevator, the combination of the lever *I*, the wheel *H*, and the dog *m*, the said dog being connected with the said lever and being pivoted at a point nearer the wheel *H* than is the pivot of said lever, for the purpose specified. 5th. In a hay, grain or fodder elevator, a trolley carrying a pivoted lever connected to a dog adapted to engage the elevating cable and a rod adapted to hold the lever in an elevated position whereby the dog is out of engagement with the cable, in combination with a stop secured to the track on which the trolley runs, a lever carried by said trolley engaging with said stop and connecting with the said rod, and means for causing said last mentioned lever to become disengaged from said stop at any desired point of elevation of the load whereby the dog is allowed to grip the cable and hold the load for descending, for the purpose specified. 6th. In a hay, grain or fodder elevator, a trolley having means for engaging and locking the elevating cable and a lever adapted to hold said means out of operation, in combination with a stop-plate supported by the track on which the trolley runs, said stop-plate having a recess in its edge in which said lever is adapted to lie and thereby prevent the trolley from travelling along the track and also prevent the cable from being locked, and means for forcing said lever out of said recess whereby it may be moved clear of said stop-plate and the elevating cable locked, for the purpose specified. 7th. In a hay, grain or fodder elevator, the combination of a track composed of a plate having elongated slots in it, and a hook for supporting the same, consisting of a shank having two wings on each side thereof, said upper and lower pairs of wings having a pair of notches between them, for the purpose specified. 8th. In a hay, grain or fodder elevator, a supporting track consisting of an inverted channel-shaped bar, having elongated slots through its upper wall, in combination with a hook consisting of a shank having projecting from it two pairs of wings, one pair being above the other pair and having a pair of notches between them, the members of each pair being substantially diametrically opposite, whereby said hook may be inserted through said slot and then turned substantially ninety degrees, thereby becoming locked and having its lower wings brace said track against a pressure tending to force the walls thereof inward, for the purpose specified. 9th. In a hay, grain or fodder elevator, a hook for supporting a track, consisting of a shank having three wings on each side thereof, the upper pair of wings and the middle pair having a pair of notches between them, and the middle and lower pairs of wings having a pair of notches between them, either of said pairs of notches being adapted to co-operate with the track whereby the latter may be supported in a choice of positions, for the purpose specified.

No. 56,237. Egg Tester.

(Appareil à faire l'épreuve des œufs.)

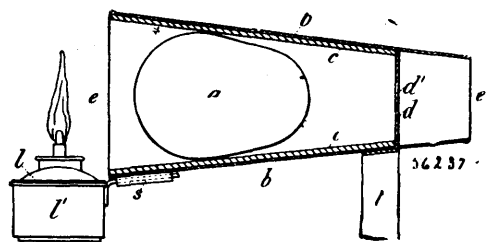

William Tyree, Wellington, New Zealand, 11th June, 1897; 6 years. (Filed 7th September, 1895.)

Claim.—1st. In an egg testing apparatus, the combination with the conical tube *b* of the lining *c*, the orifice plate *d* near the smaller end of the said tube, and a lamp socket *s* at the larger end of the said tube, substantially as set forth and described. 2nd. In an egg testing apparatus, the combination with the conical tube *b* of the lining *c*, substantially as set forth and described.

No. 56,238. Napkin Fastener.

(Attache de serviettes de table.)

Wm. A. Mason, London, Ontario, Canada, 11th June, 1897; 6 years. (Filed 11th June, 1896.)

Claim.—1st. The napkin attacher or fastener consisting of the spring finger *F*¹, formed with a hook *H*, with the curved portion *C*¹, and opening *O*, in combination with the finger *F*², formed with curved portion *C*², and the neck *A*, substantially as and for the purpose set forth. 2nd. The spring finger *F*¹, formed with a hook *H*, with the curved portions *C*¹ and *E*¹, and with the opening *O*, in combination with the finger *F*², formed with the neck *A*, and with the curved portions *C*² and *E*², substantially as and for the purpose

set forth. 3rd. The spring finger F¹, formed with a hook H, with curved portions C¹ and E¹, and with the aperture B, and opening O,

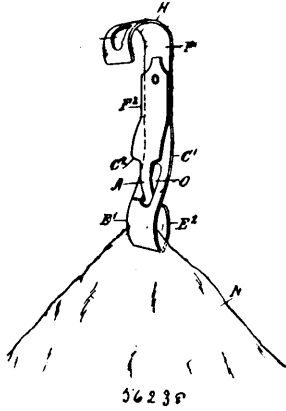

in combination with the finger F², formed with the neck A, and with the curved portions C² and E², substantially as and for the purpose set forth.

No. 56,239. Stereopticon Panorama Machine.
(Appareil stereoptique.)

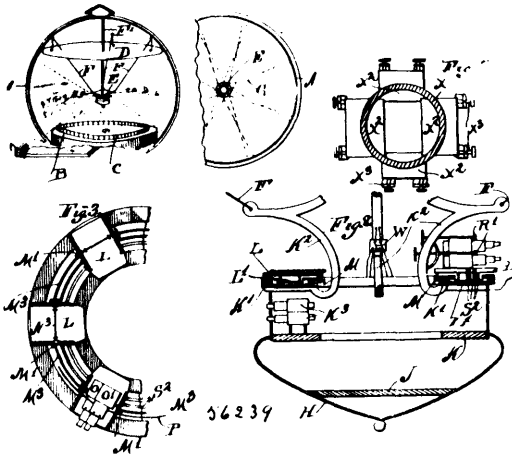

Charles A. Chase, Chicago, Illinois, U.S.A., 11th June, 1897; 6 years. (Filed 20th March, 1896.)

Claim.—1st. A stereopticon apparatus for projecting the whole or a part of a horizon view on the walls of an enclosing, spherical, cylindrical or equivalent apartment, all substantially as shown and for the purpose specified. 2nd. The combination of a polyhedral shaped apartment with a series of stereopticons grouped near the centre, a series of plates one for each stereopticon and all forming one continuous picture, and means and devices for adjusting the several parts so as to project the whole or a part of a horizon view on the apartment wall, as and for the purpose described and shown. 3rd. The combination of a building or the like A, stereopticons O, annular table K¹, carriages L, slides N, all as shown and for the purpose described. 4th. The blender having slide X² and controlling screw rods X³, in combination with stereopticons O O associated side by side so as to throw slightly overlapping pictures. 5th. The combination of a series of stereopticons adapted to reproduce wholly or partially a horizon view, with a series of slides, one for each stereopticon, each slide containing slightly more than its proportionate amount of the total picture, and movable shutters in advance of the plate to blend and reduce the light of the overlapping portions. 6th. The method of reproducing landscapes or the like consisting in photographing the entire horizon from a given point, dividing the negative into sections and preparing stereopticon plates from such sections, and then inserting said plates in a number of reproducers or stereopticons arranged so that the several sections will be projected upon a surrounding receiving surface, the contiguous or adjoining sections blending or uniting so as to form a continuous horizon view.

No. 56,240. Car Burnishing Machine. (Brunisseur.)

Guillermo Antonio Farini, London, England, and François Xavier Gaudric, Port Hope, Ontario, Canada, 11th June, 1897; 6 years. (Filed 10th March, 1897.)

Claim.—1st. In a burnishing machine, adjacent, separated burnishing devices, an interposed feed, arranged to rotate the

article while being fed. 2nd. In a can burnishing machine, adjacent, separated burnishing devices, an interposed table, a guide

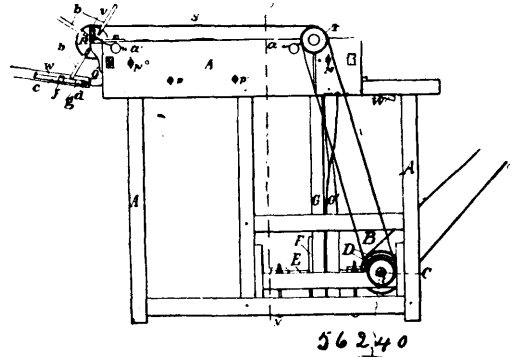

on which the can is fed, a feed belt travelling over the guide way and acting as a feed for the cans. 3rd. In a can burnishing machine, the combination of horizontally parallel, separated, rotating burnishing brushes, and an interposed feed device. 4th. In a can burnishing machine, the combination of two horizontal parallel, separated, rotating, burnishing brushes, having the teeth or bristles spirally arranged, means for rotating the brushes towards each other, and a feed for the cans between the brushes. 5th. In a can burnishing machine, the combination of adjacent separated burnishing devices, means for adjusting them in relation to each other and the interposed feed comprising a feed belt, pulleys from which the belt runs, and a spring backed support for the initial or entering pulley, substantially as described.

No. 56,241. Smoke Consuming Apparatus.
(Appareil pour consumer la fumée.)

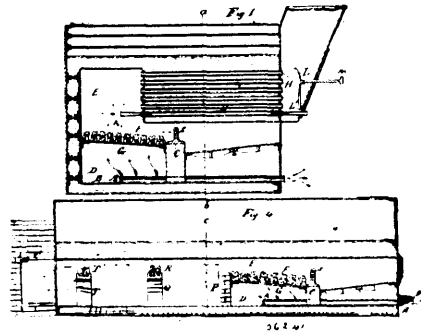

Samuel Albert Johnson, London, England, 11th June, 1897; 6 years. (Filed 10th January, 1897.)

Claim.—1st. A boiler furnace having an air duct A, discharging into an air chamber D, rearward of the fire bridge C, a perforated floor or grating G, dividing said chamber from the combustion chamber E which receives the products of combustion from the furnace, blocks or lumps E, of asbestos or fire clay placed upon said floor, and a block S, of metal superposed on the fire bridge, as set forth. 2nd. A furnace and boiler having an air duct A, discharging into an air chamber D, in rear of the fire bridge C, a metal block S, superposed on said bridge, a perforated floor or grating G, dividing said air chamber from the combustion chamber E, above, into which the products of combustion from the furnace are discharged, blocks or lumps F, of asbestos, fire clay or refractory material placed on said floor or grating, and a multi-flue boiler having one or more of the lower flues H, provided with an inlet tube J, and a perforated tube K, at the opposite end discharging into the combustion chamber E, as set forth. 3rd. A boiler furnace having an air duct A, discharging into an air chamber D, rearward of the furnace, a grating or open floor G, separating said chamber from the combustion chamber E, which receives the products of combustion from the furnace, blocks or lumps F, of asbestos or fire clay placed on said floor, a perforated block of metal S, placed on the fire bridge C, and one or more diverting bridges Q, T, rearwardly of a bridge P, supporting one end of said floor, and lumps or blocks of refractory material R, T¹, placed thereon, as set forth.

No. 56,242. Key Opened Can.
(Clé pour ouvrir les boîtes métalliques.)

Albert Frederick Remy, Mansfield, Ohio, U.S.A., 12th June, 1897; 6 years. (Filed 17th June, 1896.)

Claim.—1st. In a can or package, the head struck up from a single piece of metal and provided with circumferential bead and flange and with an inwardly-extending recess which opens into said

bead, combined with a ripping wire fitted in said bead and having a hook-shaped end, which is held in said recess and with its other

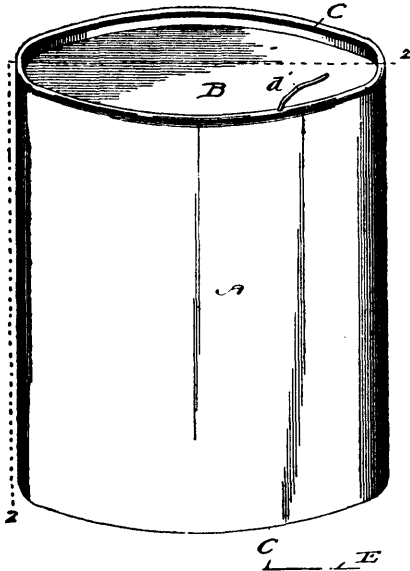

end passed through the wall of the bead, and a can-body seated in the bead, against the ripping wire therein, and united with the flange of the head, as and for the purposes described. 2nd. A head for packages, cans and the like, provided with a raised bead and with a bulged portion forming a pocket which opens into a groove formed by said bead, combined with a ripping wire, one end of which is confined in said pocket and the other end extended through the bulged portion of the head. 3rd. A head for packages, cans and the like, made of a single piece of metal with a peripheral bead and with a bulged portion which lies out of the line of the bead and forms a pocket that opens into said bead, combined with a ripping wire adapted to said bead and having a hook-shaped end which is confined in the pocket, the other end of said wire passing inwardly through the bulged portion of said head. 4th. A can-head provided with a raised or bulged portion and a slit or opening which is formed to produce a tongue or lip, combined with a ripping wire having one end held by the raised or bulged portion and its other end passed through the slit or opening, said slit or opening being hermetically sealed, as and for the purposes described. 5th. A can-head provided with a raised or bulged portion, forming on one side of said head a pocket, and with a slit or opening partially closed by a tongue or lip, and a ripping wire having a hook shaped end fitted against the bulged portion, and its other end passed through a slit or opening, said slit or opening being hermetically sealed, and the hooked end of the ripping wire securely attached by solder, which accumulates around the lip or tongue and in the pocket, respectively, of said head, substantially as and for the purposes described. 6th. A can-head having a raised circumferential bead, and the bulged or raised portion which lies within said bead, and is provided with a slit or opening partially closed by a tongue, and a ripping wire seated in a groove formed by said raised bead, and having one end raised by the bulged or raised portion, and its other end passed through the slit or opening which is hermetically sealed by a suitable agent, substantially as and for the purposes described. 7th. Co-acting dies for making can heads, the female die provided with a punch and with a puncturing tooth or spur, and the male die having a coincident cavity and recess, for the purposes described, substantially as set forth. 8th. In dies for stamping or shaping can-heads, a female die provided with a bead-and-flange-forming rib, a punch within said rib, and a spur or tooth extending above the rib and punch, combined with a male die having a groove coincident with the rib, a cavity and a recess to register, respectively, with said punch and the tooth or spur, substantially as and for the purposes described. 9th. In dies for stamping and shaping can-heads, the female die provided with a fixed punch within a rib and with a projecting tooth or spur, combined with a movable ring which surrounds said female die, and a male die having a rigid external ring, and an annular groove in its face and coincident with the rib, a cavity and the recess which register, respectively, with the punch and the tooth or spur of the female die, substantially as and for the purposes described.

No. 56,243. Manufacture of Rolled Oats, etc.

(Fabrication de gruau, etc.)

Thos. Jardine, Liverpool, England, 12th June, 1897; 6 years. (Filed 10th August, 1896.)

Claim.—1st. The treatment of oats and other cereals and the production therefrom of a cooked food which has merely to be

mixed with boiling water or boiled for a minute or two to become ready for the table, which consists of shelling or hulling the grains or seeds, then cooking them by boiling with occasional stirring, drying to such an extent as to eliminate in great measure the water absorbed by the grains during the cooking, and finally hot rolling the grains while still soft and yielding, whereby they are rolled into flakes or filaments and dried at the same time, substantially as described. 2nd. In the treatment of oats and other cereals for the production of an article of cooked food, the continuous process which consists in cooking the hulled grains or seeds, evaporating therefrom in great measure the water absorbed by said grains in the cooking, rolling them into flakes or filaments whilst still soft and yielding, and finally drying said flakes or filaments, substantially as described. 3rd. As a new article of manufacture a farinaceous food product, consisting of translucent flakes, filaments or flattened pieces of cooked hull grains of oats or other cereals, which only require to be mixed with boiling water or to be boiled for a minute or two to render them ready for the table, substantially as described.

No. 56,244. Gas Engine. (Machine à gaz.)

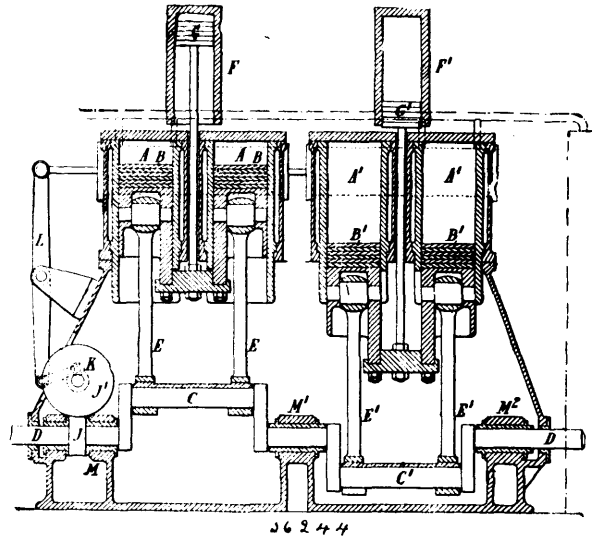

John Magee, Caledonia Place, Paisley, and James Ramsay Sandilands, Glasgow, Lanark, both in Scotland, 12th June, 1897; 6 years. (Filed 1st September, 1896.)

Claim.—1st. In gas engines, the combination with two motor cylinders the pistons of which act upon the same crank so that such pistons move in unison, of valve mechanism for controlling the supply to, compression of, firing of, and exhaust from each of such cylinders so that the piston of one of such cylinders will hold the other piston on its upstroke in thrust on the crank, all substantially as and for the purpose specified. 2nd. The combination of two sets of cylinders arranged in the manner set forth in the preceding claim, the pistons of each set of such cylinders acting upon opposite cranks of the motor shaft, substantially as and for the purpose specified. 3rd. The combination with a motor cylinder or cylinders, of an air cushioning cylinder or cylinders or cushioning spring or springs operated so as to hold the piston or pistons of the motor cylinder or cylinders in thrust on the crank shaft during its or their upstroke, all substantially as specified.

No. 56,245. Manufacture of Ozone and Apparatus therefor. (Fabrication d'ozone et appareil pour cet objet.)

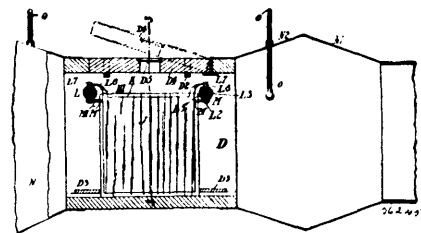

Charles John Yarnold, Brixton, Surrey, England, 12th June, 1897; 6 years. (Filed 19th August, 1896.)

Claim.—1st. An ozone generator of the kind above described which has projections or obstructions for the purpose described, in the passages traversed by the fluid treated in it. 2nd. An ozone

generator D, with corrugated plates J J', substantially as and for the purpose described. 3rd. An ozone generator D in which the casing at one end or at each end is extended to form expansion chambers N, substantially as and for the purpose described. 4th. The complete process of the manufacture of ozone, in which an oxygen-containing fluid is passed through a purifying bath B, and drying and cooling apparatus C, and thence through an ozone-generator which has projections or obstructions in the passages traversed by the fluid, finally passing through a deacidifying bath, substantially as hereinbefore described.

No. 56,246. Treatment of Complex Sulphate Ores.

(*Traitement de minerai.*)

Francis Ellershausen, London, England, 12th June, 1897; 6 years. (Filed 18th September, 1896.)

Claim.—1st. The described process for simultaneously separating the zinc (in the form of oxide of zinc) and obtaining the lead and precious metals from complex sulphide ores, such process consisting in rapidly heating the crushed ore (to which a sufficient quantity of fluxing material has been added to prevent oxidation) to red heat in a sump in a reverberatory furnace, and then adding to the mixture kept in a heated state, a sufficient quantity of molten metallic iron to effect the desulphurization of the ore, substantially as hereinbefore described. 2nd. In treating ore containing a large proportion of gangue by the process, using a bath of molten lead in the sump prior to the introduction of the ore, as and for the purpose described.

No. 56,247. Billiard Cue Holder.

(*Porte-queue de billard.*)

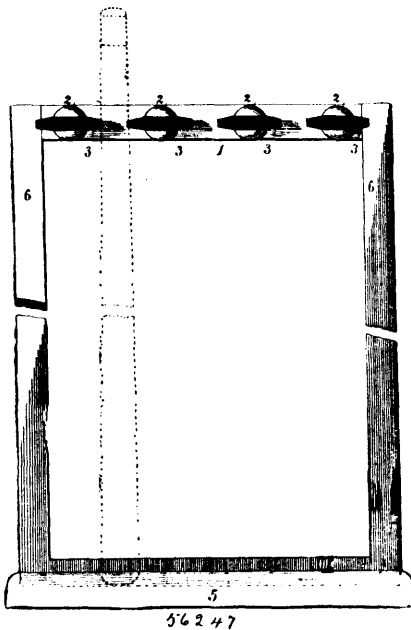

Francis Beattie, Banff, N.W.T., Canada, 12th June, 1897; 6 years. (Filed 7th December, 1896.)

Claim.—1st. A billiard cue holder comprising a support, arms carried thereby providing space for the cues, and the movable frictional retaining pieces for retaining the cues in said spaces, substantially as set forth. 2nd. A billiard cue holder comprising the support arms carried thereby, and the horizontally arranged disks movably carried by said arms for retaining the cues between the arms, substantially as set forth. 3rd. A billiard cue holder comprising a support, arms having bifurcated outer ends, and the disks journaled in said bifurcations, substantially as set forth. 4th. A billiard cue holder comprising a support, arms detachably carried thereby, and the movable frictional retaining pieces carried by said arms, substantially as set forth. 5th. A billiard cue holder comprising the base having a recessed face to receive the butt ends of the cues, the cross bar supported from said base, the arms carried by said cross bar and having bifurcated ends, and the disks journaled in said bifurcations and retaining the upper ends of the cues between the arms, substantially as set forth. 6th. A billiard cue holder comprising the support, the arms having screw shanks engaging said support, and the movable friction pieces carried by said support, substantially as set forth.

No. 56,248. Revolving Flower Stand.

(*Porte-fleurs tournant.*)

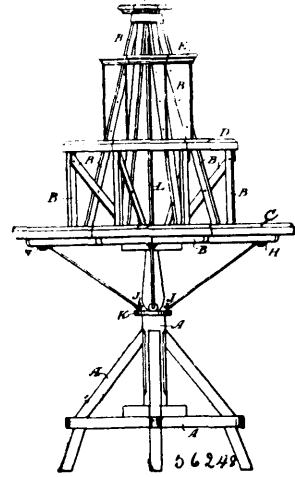

Sigurdur Anderson, Winnipeg, Manitoba, Canada, 12th June, 1897; 6 years. (Filed 24th April, 1897.)

Claim.—The combination of tiers of shelves C, D, E and F, on the framework B, with an iron rod L revolving in the pedestal or base A, substantially as and for the purpose hereinbefore set forth.

No. 56,249. Antiseptic Compound.

(*Composé antiseptique.*)

Leopold Charles Urban, both of Milwaukee, Wisconsin, U.S.A., 12th June, 1897; 6 years. (Filed 16th December, 1896.)

Claim.—1st. The herein-described process of manufacturing an antiseptic compound, consisting in adding to a given quantity of carvacrol about double the quantity, by weight, of commercial sodium hydroxid, and dissolving the same in water, forming a clear solution; next, adding to this described aqueous alkaline solution an aqueous iodine solution, under continuous stirring, at about 15° centigrade, forming a yellowish-gray or buff-coloured precipitate, and continuing this addition and agitation until no more of the said precipitate is formed; next, separating this precipitate by filtration and carefully washing it with cold distilled water and finally spreading out the purified mass on an absorbent surface, and air-drying the said precipitate at a temperature of about 15° to 18° centigrade. 2nd. The herein-described new iodine-substitution product of carvacrol, consisting of an amorphous practically odorless powder of a yellowish-gray or buff colour, insoluble in water and alkali, sparingly soluble in alcohol and readily soluble in ether, chloroform, benzene or other light and volatile petroleum distillates and in various expressed vegetable oils, such as olive oil, cotton-seed oil and the like, and incapable of melting under about 153° centigrade.

No. 56,250. Mould for Casting Brake Shoes and Products therefor.

(*Moule pour couler les sabots de freins, etc.*)

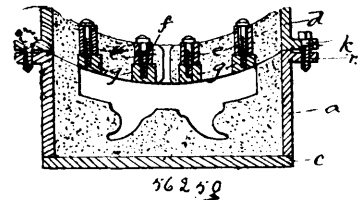

David McIntosh, Montreal, Quebec, Canada, 12th June, 1897; 6 years. (Filed 2nd February, 1897.)

Claim.—1st. A mould having one or more chills suspended therein, for the purpose set forth. 2nd. A mould for casting chilled brake shoes comprising a drag and cope with a chill or chills permanently connected with said cope, for the purpose set forth. 3rd. In a mould for casting chilled brake shoes, the combination of the drag 2, the cope d having transverse webs e, e, and chills g, suspended by said webs, for the purpose set forth. 4th. In a mould for casting chilled brake shoes, the combination of the drag a, the cope d, having transverse perforated webs e, e, chills g, and screw bolts f, for securing said chills to the webs, for the purpose set forth. 5th. A brake shoe cast with its bearing face up and chilled, and the lugs on its rear face projecting downward and toughened by retarded cooling, as described and for the purpose set forth.

No. 56,251. Siphon. (*Siphon.*)

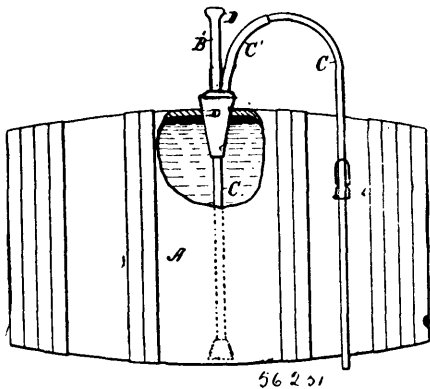

Frank Stebbins Hillhouse and Horace B. Peck, both of Kalamazoo, Michigan, U.S.A., 12th June, 1897; 6 years. (Filed 15th March, 1897.)

Claim.—1st. In a combined bung and siphon, the combination of the tapered bung B, containing the enlarged passage D², a branch passage therefrom out at the top of the bung, the handle B¹, extending upwardly from the centre thereof with an aperture D¹ therethrough joining to the enlarged passage D², and enlarged in the disc D at the top, a tube C inserted into the top of the bung and connected to the branch passage to the enlarged passage D², a siphon pipe or tube C inserted through the pipe C¹, down through the enlarged passage D², all co-acting together substantially as described for the purpose specified. 2nd. In a combined bung and siphon, the combination of the tapered bung B, containing the enlarged passage D², a branch passage therefrom out at the top of the bung, the handle B¹, extending upwardly from the centre thereof with an aperture D¹ therethrough joining to the enlarged passage D², and enlarged into a disc D, at the top, a pipe C², adapted to connect to the top of the passage D¹, from the handle B¹, a tube C¹ inserted into the top of the bung and connected to the branch passage to the enlarged passage D², a siphon pipe or tube C, inserted through the pipe C¹, down through the enlarged passage D², all co-acting together substantially as described for the purpose specified. 3rd. In a combined bung and siphon, the combination of the tapered bung with an enlarged passage extending upwardly therein and branching out at the top of the bung at one side, a handle or stem extending upwardly from the centre of said bung and containing a passage which connects to the top of the enlarged passage in the bung, a siphon tube smaller than the enlarged passage in the bung adjustably inserted through the branch passage out at the top of the bung, co-acting together substantially as described. 4th. In a combined siphon and bung, the combination of a tapered bung with an upwardly projecting handle therein enlarged at the top into a disc having a passage extending downwardly through the same, and a siphon pipe adjustably inserted in said bung so as not to entirely close the passage through the bung and handle, for the purpose specified.

No. 56,252. Nose-piece for Eyeglasses.
(*Appui-nez pour monocles.*)

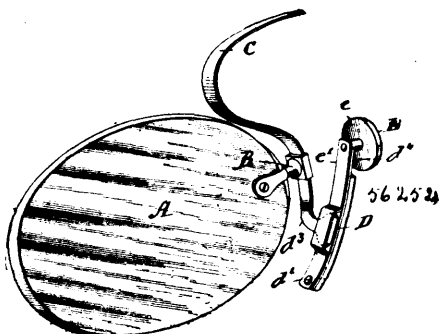

F. A. Hardy & Co., assignee of Henry Borsch, all of Chicago, Illinois, U.S.A., 12th June, 1897; 6 years. (Filed 24th March, 1897.)

Claim.—1st. In a nose-piece, the combination of a main pad, an auxiliary pad and means supporting them so that they are adapted to bear upon the nose independently of each other and so that the auxiliary pad is adapted to yield more readily than is the main pad to pressure exerted upon its face, substantially as set forth. 2nd. In a nose-piece, the combination of a main pad, means for supporting it so that when in use it is practically unyielding, an auxiliary

pad, and means for supporting it and tending constantly to project it beyond the face of the main pad (toward the nose) with a yielding force, substantially as set forth. 3rd. In a nose-piece, the combination of a main-pad, means for supporting it so that when in use it is practically unyielding, an auxiliary pad disposed substantially in line with the main pad, and means for supporting the auxiliary pad and tending constantly to project it beyond the face of the main pad (toward the nose) with a yielding force, substantially as set forth. 4th. In a nose-piece, the combination of a main pad, means for supporting it so that when in use it is practically unyielding, an auxiliary pad, and a spring engaging the auxiliary pad and tending constantly to project it beyond the face of the main pad (toward the nose) with a yielding force, substantially as set forth. 5th. In a nose-piece, the combination of a main pad, a base-plate supporting it so that when in use it is practically unyielding, an auxiliary pad, and a spring engaging the auxiliary pad and tending constantly to project it beyond the face of the main pad (toward the nose) with a yielding force, said spring being in turn supported by the base-plate of the main pad, substantially as set forth. 6th. In a nose-piece, the combination of a main pad, means for supporting it so that when in use it is practically unyielding, an auxiliary pad, means tending constantly to project the auxiliary pad beyond the main pad (toward the nose) with a yielding force, and means for guiding the auxiliary pad, substantially as set forth. 7th. In a nose-piece, the combination of a main pad, a base-plate supporting it so that when in use it is practically unyielding, an auxiliary pad, and a spring, secured to the base-plate of the main pad, by which the auxiliary pad is supported and carried, the parts being so constructed and arranged that the spring tends constantly to project the auxiliary pad beyond the face of the main pad (toward the nose) with a yielding force, substantially as set forth.

No. 56,253. Mould for Casting Metal Articles.
(*Moule pour couler des objets en métal.*)

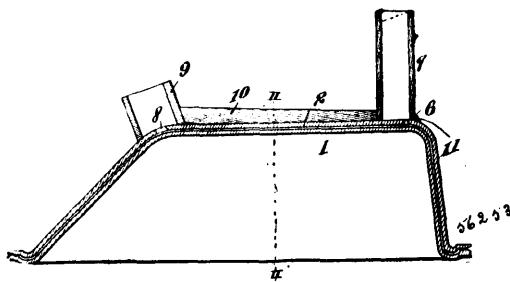

Louis Jacob Crecelius and the Western Brass Manufacturing Company, all of St. Louis, Missouri, U.S.A., 12th June, 1897; 6 years. (Filed 29th March, 1897.)

Claim.—1st. A mould composed of members having plane faces in contact, the edges of said members beyond the plane faces being divergent to form V-shaped channels to the outer edges of the mould to receive a packing, substantially as described. 2nd. A mould composed of two members of material fusible at a higher temperature than the fusing temperature of the ingot to be cast, one of said members being provided with an inlet and a feed port adapted to permit the feeding of molten material to the ingot to fill the mould on shrinkage of the ingot, substantially as described. 3rd. A mould composed of members providing an interior cavity, detachable means for holding said members together, one of said members being provided with an inlet, a gate located over said inlet, an escape and feed port provided in the member containing said inlet, and a gate located on said member and surrounding said port, substantially as described. 4th. A mould composed of a lower member 1, and an upper member 2, said upper member being provided with an inlet 6, and with an outlet port 8, said outlet port being of greater dimension than said inlet, a gate 7 located on said member surrounding said inlet, and a gate 9 located on said member, and surrounding said outlet port, and detachable means for holding said members together, substantially as described. 5th. A mould composed of a lower member and an upper member, and provided with a cavity between them, said upper member being provided with an inlet and an outlet port removably combined, gates adapted to be located on said upper member and surrounding said inlet and outlet port, a packing surrounding each of said gates, and means for detachably holding said members together, substantially as described. 6th. A mould for casting sanitary articles, composed of lower and upper members provided with a cavity between them, means for detachably holding said members together, an inlet and an outlet port in said upper member, and suitable gates located on said upper member surrounding said inlet and outlet ports, substantially as described. 7th. A mould composed of separable lower and upper members, said upper member being provided with an inlet and a feed port and a heat retaining bar located on said upper member, substantially as and for the purpose set forth. 8th. A mould composed of separable lower and upper mould members, said upper member being provided with an inlet and a feed and gas

escape port, said mould being arranged during the act of moulding with said feed and gas escape port at a greater elevation than said inlet, substantially as and for the purpose described.

No. 56,254. Perforator. (Perforateur.)

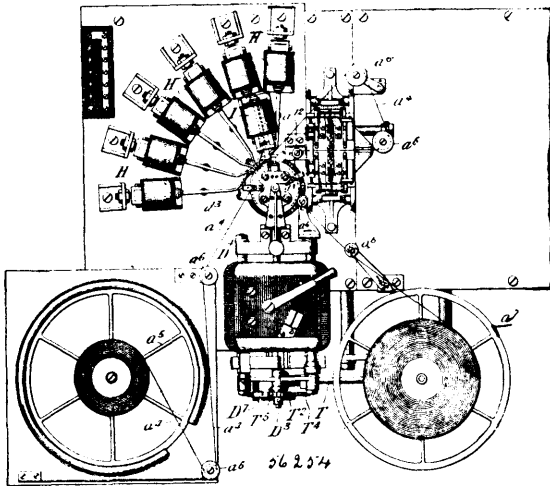

Charles L. Buckingham, New York, assignee of Joseph Gardam, and Emil Germann, both of Brooklyn, all in the State of New York, U.S.A., 12th June, 1897; 6 years. (Filed 29th March, 1897.)

Claim.—1st. The combination, substantially as described, of a series of punch actuating magnets, a series of circuit selecting keys for operating said punches, a paper feed, and a series of feed controlling magnets, different ones of which are brought into action by said keys according to the extent of feed required. 2nd. The combination in a perforator, of a gang of punch operating devices, a series of controlling keys, a variable paper feed provided with a series of setting devices for predetermining the extent of feed, means controlled by said keys upon the depression thereof for bringing different ones of said setting devices into action according to the length of feed required, a motor for imparting a continuous rotary tendency to said feed wheel, a fixed stop for arresting said wheel, and means for releasing said setting devices. 3rd. The combination with a series of punch actuating magnets, of a series of circuit selecting keys, a variable feed device having a series of stop pins, a series of stop pin setting magnets, and circuit controllers therefor governed or operated by said keys. 4th. The combination with a series of punch-actuating magnets, of a series of circuit selecting keys, a variable feed device having a series of stop pins, a series of stop pin setting magnets, a series of circuit controllers therefor connected to the keys, a stop pin releasing device, and means for actuating the same when the punches are withdrawn from the work. 5th. In a perforator, the combination, substantially as described, of a series of punch actuating devices, a series of controlling keys for selecting the punches to be actuated, a feed mechanism, a series of dogs operating on the same to set and prepare said mechanism for a feed movement different in extent for the different dogs, actuating devices controlled by said keys for actuating different ones of said dogs according to the key depressed, a releasing device for said feed mechanism, and means for actuating the same when the punches are withdrawn from the work. 6th. The combination of a series of punch actuating or controlling magnets, a series of key levers, a series of chains or cords transverse thereto and engaged thereby in different groups or combinations according to the perforations desired, a series of circuit closers connected with said chains, paper feed devices, a series of stop setting magnets for the paper feed, and circuit controllers for said magnets connected to a set of supplemental chains or cords engaged by said key levers, as and for the purpose described. 7th. The combination with a keyboard perforator wherein the depression of one of the keys produces the desired group of sequence of perforations, an escapement wheel having a series of movable teeth or pins, a fixed stop or abutment for arresting said teeth or pins, and means controlled by each of said keys whereby when the same is depressed to actuate the desired punches it at the same time sets or moves a pin sufficiently far removed from said fixed stop or abutment to permit a feed movement of the desired length to take place. 8th. As a means for obtaining any desired intermittent rotation of irregular steps, a variable feed escapement wheel having a series of sliding stop pins or teeth, each adapted to be set into or out of position for engagement with a stop, and means for setting these pins at any required position with reference to said stop. 9th. The variable feed escapement wheel herein described, provided with a series of movable stop pins, a series of setting arms or levers having stationary supports operating on said pins singly or one at a time for each step of rotation, a stationary stop, and a detent arm or lever adapted to engage with and reset the pin, which for the time being is in engage-

ment with the stationary stop. 10th. A variable feed escapement wheel having a series of movable stops, pins or teeth normally out of the path of a stop, means for independently setting said stop pins or teeth into and out of operative position, one at a time for each step of rotation, a stop for arresting said pins, said pins being adapted to be moved in the wheel in a direction transverse to the plane of the wheel, and means for holding said pins in the position in which they are set. 11th. A variable feed escapement wheel having a series of movable stop pins or teeth adapted to be independently set into and out of operative position, one at a time for each step of rotation, a stop for arresting said pins, a series of setting devices for setting said pins, and a pair of centreing cam plates between which the pins move before reaching said setting devices. 12th. The combination with the escapement wheel, having movable stop pins or teeth, of a releasing arm or dog adapted to yield when engaged by a pin, as and for the purpose described. 13th. The combination with the escapement wheel having movable stop pins, of a series of setting arms or dogs, and a releasing arm for engaging with the pin which engages with a fixed stop or abutment, said arm being adapted to yield and move past the abutment when engaged by the pin which has been set to next engage said abutment. 14th. The combination, substantially as described, of an escapement wheel carrying a number of movable stop pins or teeth, a series of stop setting magnets acting on pins at different distances from a fixed stop and a stop pin releasing magnet for actuating the pin by which the wheel is held from movement. 15th. The combination of a series of actuating magnets operated in different combinations, a variable feed wheel carrying a series of movable stop pins, a series of setting magnets different ones of which are operated according to the combination of actuating magnets operated and length of feed required, a stop pin resetting magnet, and a circuit controller therefor governed by the said actuating magnets and adapted to act only when all of the actuated devices return to normal position. 16th. The combination, substantially as described, of a series of punches, a series of actuating magnets therefor, feed mechanism provided with an escapement wheel whose teeth or pins are adapted to be set into and out of position to engage a stop, a series of actuating magnets for setting said pins one at a time, a tooth resetting magnet for releasing the wheel, and a circuit controller therefor engaged by the punch mechanism or part moving therewith. 17th. The combination in a perforator, of a series of punches, a paper feed mechanism having a variable feed wheel, a series of stop setting devices for predetermining the extent of feed, a releasing magnet for resetting said stops and freeing the wheel to allow the feed to take place, and a circuit controller therefor connected with the punches. 18th. The combination with a typewriter, of a series of circuit controllers actuated by the typewriter levers, and a circuit breaker engaged by the typewriter carriage at the end of a line for opening the circuits of said circuit controllers. 19th. The combination of a series of operating magnets, a series of circuit selecting keys, a magnetically actuated marker and means controlled by said keys for closing a circuit of said marker after a predetermined number of operations of said keys. 20th. The combination with a series of punch operating magnets, a series of circuit selecting key levers, an escapement connected with said levers, a traveller moved step by step thereby, and a circuit breaker adapted to be engaged by said traveller to open the circuit of the magnets after the operation of a predetermined number of keys. 21st. The combination with a series of punch operating magnets, a series of circuit closers, a typewriter whose keys or key levers are provided with selecting devices acting on said circuit closers, and a circuit breaker engaged by the paper carriage for opening the circuit at the end of a line. 22nd. The combination, substantially as described, of a series of punch actuating magnets, a series of circuit controlling keys or levers therefor, and mechanism for opening the circuit of said magnets upon the operation of a predetermined number of keys equal to the number of spaces or characters in each of the lines of the message. 23rd. The combination with a series of independent actuating magnets and their retractors, of one or more magnets placed in a common return circuit for said actuating magnets, and connected to the mechanism so as to assist the actuating magnets in overcoming the retractor. 24th. The combination, substantially as described, of a series of punches and independent actuating magnets therefor, of retracting devices operating on the armature of said magnets, and an assisting magnet or magnets for assisting the said actuating magnets in overcoming their retracting devices. 25th. The combination, substantially as described, of the paper feed wheel, the take up reel and a driving motor common to the two wheels, a spring between said motor and paper feed wheel, and a ratchet and pawl connection between the motor and take up reel whereby the motor may be turned backward without affecting the take up reel and its driving connections. 26th. The combination of a paper feed wheel having a series of independent movable teeth or pins, and a fixed stop, substantially as described, whereby the said feed wheel shall have a definite predetermined irregular step of rotation, a take up reel on which the paper is wound as fast as fed from said feed wheel, a driving motor for said wheel, and an intermediate frictional driving connection for compensating for increase in the size of the roll of paper. 27th. A feed paper wheel having on its periphery teeth adapted to engage with perforations in the paper to be fed, and provided with stop pins or teeth adapted to be set into and out of position to engage with a suitable stop. 28th. In a perforator, the combination with the paper feed wheel

having teeth entering perforations in the paper, of means for freeing said wheel from its driving power to permit the paper to be adjusted freely in front of the punches while engaged with said wheel. 29th. The combination, substantially as described, with the feed escapement wheel and its driving spring, means for mechanically connecting the two ends of said spring to prevent the same from unwinding, as and for the purpose described. 30th. The combination, substantially as described, of a paper feed escapement wheel having movable stops or pins for determining irregular steps of rotation, a stop for arresting the said wheel in definite positions, an actuating spring for driving said wheel, a driving motor for winding up said spring, a take up reel, and a belt connection between said reel and the paper feed wheel or driving wheel therefor. 31st. The combination, substantially as described, of the driving wheel connected at one end to a spiral spring, a drum connected at the other end to said spring, and a locking device connecting said driven wheel and drum together at will, as and for the purpose described. 32nd. A variable feed escapement wheel having adjustably movable top pins or teeth set staggering, and a stop for arresting said wheel, as and for the purpose described. 33rd. The combination with the punches and the feed wheel over which the paper strip is fed, of means for adjusting the length of paper strip between the feed wheel and the egress side of the punch box or head, as and for the purpose described. 34th. The combination with a series of punch actuating devices and a series of controlling keys for bringing the same into operation in different combinations, of a rub out key for bringing said punch actuating devices into operation so as to produce a continuous series of holes uniformly spaced. 35th. In a perforating system, the combination, substantially as described, of a fillet of paper with a central row of perforations, a mechanism for perforating holes in the borders of said fillet, a feed wheel whose teeth engage with the central row of perforations for moving said fillet of paper, and a means for adjusting the length of paper between said feed wheel and a punch head for perforating the outer holes of the fillet whereby the the outer perforations in the fillet are brought into transverse alignment with those of the central row, as and for the purpose set forth. 36th. As a means of automatically transmitting messages for reproduction by a page printer at a distant station, a tape in which said messages are perforated, one line following another in series upon said tape and each line consisting first of groups of distinctive perforations for so marking each line of character as to produce pulsations that shall not materially affect the receiving instrument. 37th. The combination, substantially as described, of a series of punch actuating magnets, a feed mechanism, a series of feed controlling magnets governing the extent of feed, a series of controlling keys governing the circuits of said punch actuating and feed controlling magnets, and a circuit making and breaking device placed in a common circuit of said magnets and controlled or operated by said keys in common. 38th. The combination, substantially as described, with a series of punch actuating mechanisms and their controlling keys, of a variable feed mechanism, a series of feed controlling magnets in separate circuits governed by said keys according to the length of feed required, and a circuit maker and breaker common to said circuits and governed by said keys in common. 39th. In a perforator, the combination of a variable feed controlling wheel, having a series of movable stop pins or teeth adapted to set into and out of position for engagement with a stop, a series of magnets operating respectively on pins located at graduated distances from the stop, a series of circuit controlling and actuating devices for operating different ones of said circuit controllers according to the length of feed required, and a circuit maker and breaker placed in a common circuit of said magnets and operated by said actuating devices in common. 40th. The combination, substantially as described, of the paper feed wheel having pins or teeth engaging a line of perforations in the paper both before and after it passes the punches, and a pivoted take up wheel or idler bearing on the paper between the feed wheel and the ingress side of the punch box or head for stretching the paper fillet within said punch head, as and for the purpose set forth. 41st. The combination in a perforator, of a series of magnets, punch actuating mechanism operated thereby, a paper feed wheel having pins or teeth engaging a line of perforations in the paper, and provided also with a series of invariable stop pins, a series of magnets for adjusting different ones of the said pins into position to engage with a stop, a magnet operating on said pins to adjust them into position to be freed from the stop, and a circuit controller therefor connected to the punch actuating mechanism. 42nd. The combination with the variable feed wheel having stop pins set staggering, of a releasing dog, and a stop plate provided with a recess into which the dog may be retired when struck by a pin, as and for the purpose described. 43rd. A feed wheel for feeding a fillet of paper, a motor for applying a continuous propelling force to the said feed wheel for effecting rotation, escapement teeth or stops moving with the wheel which are movable relatively to said wheel for releasing the same, and a stop for arresting said escapement teeth or stops in a definite position, as and for the purpose set forth. 44th. A feed wheel for feeding a fillet of paper moving through steps of various length, a motor for applying a continuous propelling force for rotating said wheel, a series of escapement teeth or stops moving with said wheel which are movable relatively thereto, and a stop for arresting said wheel in definite positions.

No. 56,255. Perforator. (*Perforateur.*)

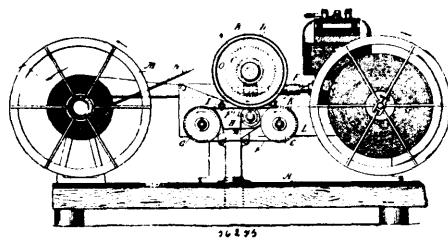

Charles L. Buckingham, New York, assignee of Emil Germann, Brooklyn, all in the State of New York, U.S.A., 12th June, 1897; 6 years. (Filed 29th March, 1897.)

Claim.—1st. In a punching apparatus, the combination, substantially as described, of a punch-wheel having radially projecting punches, and a series of co-operating dies formed as a flexible band or strip. 2nd. In a punching apparatus, the combination, substantially as described, of a wheel carrying a series of radially projecting punches, and a perforated metal band forming a die plate for said punches. 3rd. The combination, substantially as described, of the punch-wheel, the endless die band, and the grooved supporting wheel beneath the band at the point where it is engaged by the punches. 4th. The combination, with the endless die band, of the toothed clearance wheel meshing therewith, as and for the purpose described. 5th. The combination, with the travelling die band, of the wheel having its surface over which the band passes, formed with a grooved periphery, as and for the purpose described. 6th. The combination of the punch-wheel shaft, the punch-wheel, a perforated metal band forming the die plate for said punches, a motor for driving said punch-wheel and die plate, and the take up wheel belted to the shaft of said punch-wheel.

No. 56,256. Cigar and Ash Holder and Receiver and Like Articles. (*Porte-cigares et réceptacle à cendre, etc.*)

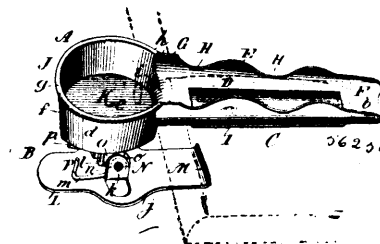

George Holt Fraser, assignee of George Farnsworth Prendergast, both of New York, State of New York, U.S.A., 12th June, 1897; 6 years. (Filed 27th March, 1897.)

Claim.—1st. In articles of the described character, a holder for application to the top of tables and other objects, and fastening means for engaging the underside of such objects and retaining said holder in place, and a pivotal connection between said holder and fastener traversing the edge of the object to which said parts are applied, said holder having on its top face provisions for receiving and holding cigars and other articles, and said fastener having a handle outwardly of its pivotal connection to said holder. 2nd. In articles of the described class, a receiver adapted to be carried on the upper side of tables and like objects, and attaching means adapted to engage the underside of the object to which the receiver is applied, and a connection between said means and the bottom of said receiver adapted to traverse the edge of said object, said receiver having a compartment for holding cigar ashes and other deposits, and having a portion projecting beyond the edge of such object, and said fastening having a handle under such portion, substantially as and for the purpose set forth. 3rd. A holder for cigars and the like, consisting of a member having an oblong, trough-like upper side and an under bearing portion adapted to rest on the top of a table or other object, and having transverse notches H, in its side walls. 4th. A holder for cigars and the like, consisting of a member having an oblong concave compartment for the cigar and transverse grasping apertures through the opposite walls of said compartment at the sides of said compartment, and having bearings for resting on the top of a table or other object. 5th. A receiver for cigar ashes and other articles, adapted to be supported at and depend over the edge of a table or other object, a bearing portion connected to said receiver for engaging the upper part of a table or other object, and means for engaging the under face of the table or other object, connected pivotally to the bottom of such receiver for attaching the latter to such an object, and having a handle under the receiver. 6th. A cigar holder and ash receiver connected together, consisting of a trough-shaped body and a substantially cylindrical flat-bottomed cup at the end thereof, both formed of a single integral metal plate, and an elastic

fastener connected to said parts for attaching both separately to a table or other object, having a handle under said cup, and a clamping portion under said trough. 7th. The holder E and receiver J, the former having means resting on a table or other object, and the latter connected to said holder and projecting beyond said object, and a fastening for holding said holder removably to the object to which it is applied, consisting of a plate pivoted to the bottom of said receiver, having an inner clamping end and an outer handle under the edge of said receiver, and a spring between said handle and receiver. 8th. The top member A and fastening B, ears k, plate O, pin N, and spring P, substantially as set forth. 9th. The top member A, and fastening B, a spring operating said fastening, and a stop for the latter. 10th. The top member A, and fastening B, projecting ears fixed to said parts, a tubular rivet pivoting them together, and a spring between them operating the fastening. 11th. The top member A and fastening B, projecting ears fixed to said parts, a tubular rivet pivoting them together, and a spring between them operating the fastening, having a bent end serving as a stop m.

No. 56,257. Extincteurs chimiques sur charriots.
(*Fire Extinguisher.*)

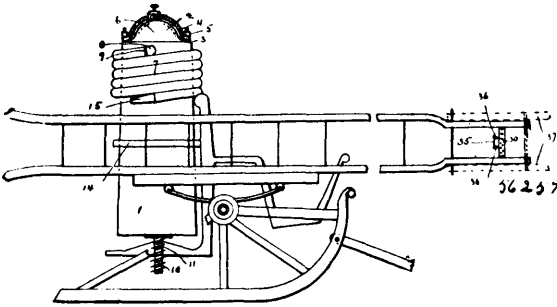

Jean-Baptiste Lalime et Joseph Côté, cessionnaire à Arthur Hypolite Durand, tous de Montréal, Québec, Canada, 12 juin 1897; 6 ans. (Filed 12 février 1897.)

Résumé.—1er. Dans un extincteur, la combinaison d'un tonneau en bois, portant sur des galets 13 et un pivot vissé 10, autour duquel s'enroule le boyau. La tête métallique 2 hermétiquement boulonnée et portant le mécanisme de mélange 6; accompagné d'échelles, le tout est monté sur un véhicule; tel que décrit.

2e. Une lance en forme de poignée pouvant se fermer ou s'ouvrir, par la seule main qui le dirige, et formée d'un bouchon 19, mû par une bielle 23, et un levier 22, et pressé sur le bout de la lance par un ressort 27, tel que décrit.

No. 56,258. Wrench. (*Clé à écrou.*)

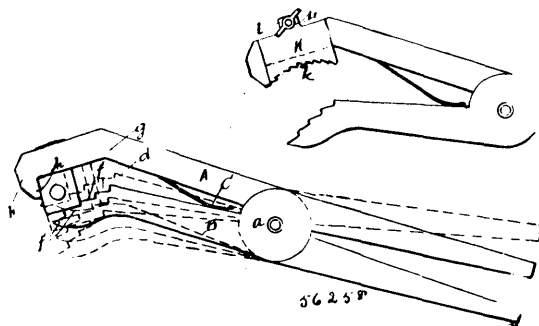

John Francis Tiner, Sutherland Springs, and Ella Jane Newton, Austin, both in Texas, U.S.A., 14th June, 1897; 6 years. (Filed 31st March, 1897.)

Claim.—1st. In a wrench, the two inter-pivoted members A and B, having elongated shanks forward of their pivotal points, the shank of one member terminating in an inwardly bent jaw portion having the claw or shoulder h, and the other of said shanks terminating in an outwardly bent jaw portion, the inner face of which is formed with a series of steps or offsets whose longitudinal walls are arranged to be successively brought into substantially parallel relation to the face of the opposite jaw portion adjacent to the claw as the jaws are closed, and whose transverse walls are arranged to come into similar relation to the inner face of said claw, substantially as specified. 2nd. In a wrench, the two inter-pivoted members A and B, having elongated shanks forward of their pivotal points, the shank of one member terminating in an inwardly bent jaw portion having the claw or shoulder h, and the other of said shanks terminating in an outwardly bent jaw portion, the inner face of which is formed with a series of steps or offsets arranged in the

manner described, in combination with the attachment X adapted to be detachably secured to one of said jaw portions, substantially as and for the purpose described.

No. 56,259. Adjuster. (*Ajusteur.*)

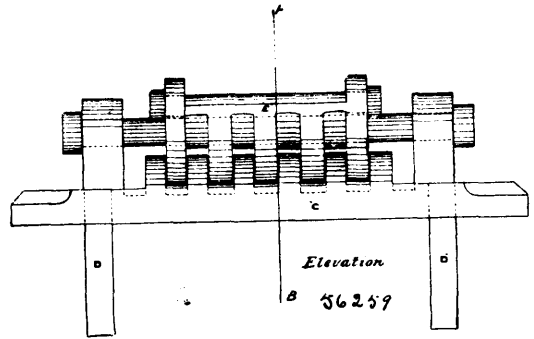

Louis Leroque and Archibald McGillis, both of Port Arthur, Ontario, Canada, 14th June, 1897; 6 years. (Filed 4th May, 1897.)

Claim.—The combination of the parts C, E, F and H, substantially as and for the purpose hereinbefore set forth.

No. 56,260. Draught Equalizer. (*Régulateur de tirage.*)

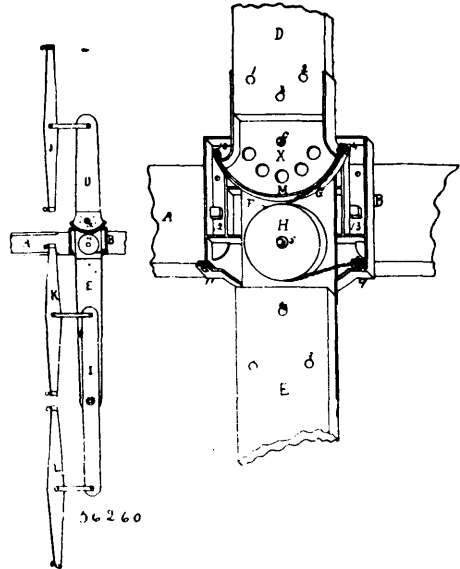

William E. Stafford, Wesley A. Stafford and Edwin W. Edwards, all of Shedden, Ontario, Canada, 14th June, 1897; 6 years. (Filed 21st May, 1897.)

Claim.—1st. The combination with the pole of a vehicle or implement, of a pole-plate secured thereto, and provided with a trunnion for draught levers to turn upon, substantially as and for the purpose hereinbefore set forth. 2nd. The combination with the pole of a vehicle or implement, of the pole-plate B, and the draught-levers D and E, substantially as and for the purpose hereinbefore set forth. 3rd. The combination with the pole-plate B, of the draught levers D and E, trunnioned thereon and secured to each other, substantially as and for the purpose hereinbefore set forth. 4th. The combination of the draught levers D and E, the chain G, and the pulley H, substantially as and for the purpose hereinbefore set forth. 5th. The combination in a draught equalizer of the pole-plate B, the draught levers D and E, and the connecting chain G, with the pulley H, substantially as and for the purpose hereinbefore set forth.

No. 56,261. Process of Extracting Fat from Wool.

(*Procédé pour extraire la graisse de la laine.*)

Parker Cairns McIlhiney, New York, State of New York, U.S.A., 14th June, 1897; 6 years. (Filed 9th December, 1896.)

Claim.—1st. The process of cleansing and extracting fat and grease from wool, which consists in washing the wool with a solvent such as rectified petroleum or other liquid having a boiling point substantially between 170° and 250° centigrade, the solvent being maintained at a temperature which will not injure the wool, and

afterwards recovering the solvent by distillation. 2nd. The process of cleansing and extracting fat or grease from wool, which consists

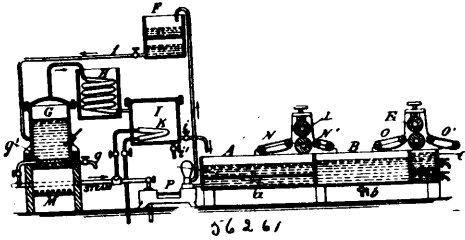

in washing the wool with a solvent such as rectified petroleum or other liquid having a boiling point substantially between 170° and 250° centigrade, the solvent being maintained at a temperature which will not injure the wool, separating the wool from the solvent, and subjecting the solvent containing the fat or grease to distillation with the aid of free steam to separate the solvent from the fat or grease, substantially as specified.

No. 36,262. Repeating Magazine Firearms.
(Magazine de fusil à répétition.)

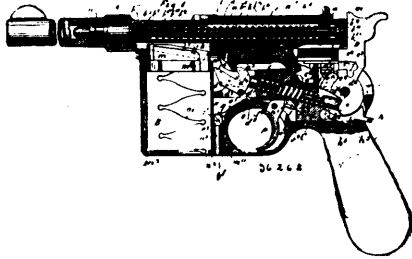

Paul Mauser, Obendorf, Wurtemberg, Germany, 14th June, 1897; 6 years. (Filed 14th November, 1896.)

Claim.—1st. A recoil operated firearm with a movable barrel and a breech bolt locking device, in which the unlocking and opening of the breech bolt after firing can only be effected when the recoil barrel A, after having cocked the hammer by means of a nose as provided on an extension as at the rear end of the breech case a, has arrived at the end of its rearward movement, whereupon simultaneously with the unlocking of the breech bolt the barrel is locked and held in this position, till the released breech bolt, after having ejected the empty cartridge case in its rearward movement, owing to the momentum given to it by the recoiling barrel, re-advances under the influence of a locking spring b² pushing a fresh cartridge from the magazine into the barrel and becomes again locked in its forward position through the upwardly moving block c, whereby at the same time the barrel is again unlocked and pushed forward to its firing position when only the firing of another shot can be effected substantially as herein shown and described. 2nd. In a firearm of the character herein described a locking block c pivoted to the breech case a and serving to alternately lock the breech bolt b in its firing position and the barrel A in its rearward position, such block being actuated by the main spring d in such a manner that the latter causes both the unlocking of the breech bolt and the advancing movement of the barrel substantially as herein shown and described. 3rd. In a firearm of the character herein described the arrangement and combination with the hammer d and the bolt locking c of a main spring d in such a manner as to enable it to act upon the hammer as well as to effect the unlocking of the breech bolt b after the shot and the advancing movement of the barrel substantially as herein shown and described. 4th. In a firearm of the character herein described, a trigger mechanism with a trigger p, arranged in a trigger piece o, and a spring q acting upon the trigger and also serving for fixing the magazine bottom plate, said trigger acting with its nose p¹ on the trigger bar f only till the gun is fired and pushing off said bar against a shoulder o⁴ on the trigger guard piece o, thus permitting the trigger bar to re-cock the recoiled hammer substantially as herein shown and described. 5th. In a firearm of the character herein described, a safety device g whereby both the hammer in its cocked and uncocked position and at the same time the barrel and the breech bolt can be secured substantially as herein shown and described. 6th. In a firearm of the character herein described, the combination of the magazine B¹ and a lock case B into one, the said magazine having a removable bottom plate held in its closed position by means of a bolt m³ actuated by the trigger spring q whilst the feeding plate n, on the magazine becoming empty, abuts with its rear edge against the front side of the recoiled breech bolt b to prevent the advancing movement of the breech bolt and thereby indicate that the store of cartridges is exhausted, substantially as herein shown and described. 7th. In a firearm of the character herein

described, the connection of the barrel A and the lock C with each other and with the lock case B without the aid of screws by pushing them from the rear into the lock case and fixing them by means of a lock holder h pivoted at the rear end of the lock body C and caused by a spring h¹ to enter with its nose h⁵ a recess h⁶ in the lock case whilst it is held in this position by the tail piece c of the uncocked hammer D and cannot be released to take away the barrel and the lock from the lock case until the hammer is cocked, substantially as herein shown and described.

No. 56,263. Machine for Manufacturing Bottles, etc.
(Machine pour la fabrication de bouteilles, etc.)

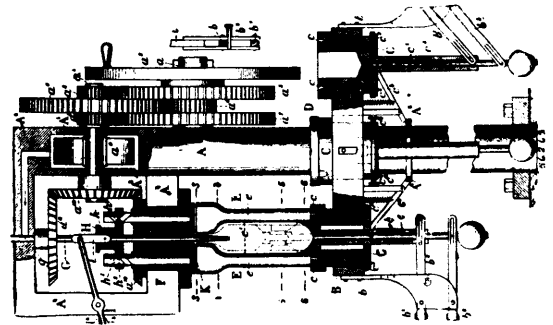

Jean Baptiste Vernay, Paris, France, 14th June, 1897; 6 years. (Filed 9th December, 1896.)

Claim.—1st. In a machine for manufacturing bottles and other articles of blown glass, the use of rotating templets successively giving to the articles the ball shape and the outer definitive shape, and the combination of these templets with a rotating rod penetrating axially into the mass of glass to effect the blowing. 2nd. The combination with these templets of a rotating disc carrying cups which are successively placed underneath the templets to bring to them the charge of glass, these cups rotating or otherwise with the templets. 3rd. In a machine for manufacturing bottles and other articles of blown glass, the use of templets for making the ring in combination with a mould of any type for shaping the body of the article. 4th. In a machine for manufacturing articles of unblown glass, the use of rotating templets to give the outside shape and the combination of these templets with a rotating mandril also penetrating axially into the mass of glass to give the inside shape to the articles. 5th. The combination with the cups and templets of two concentric rods for giving shape to the bottom of the articles to be manufactured. 6th. In a machine for manufacturing blown or unblown bottles or other articles of glass, the use of templets fixed in their journal. 7th. In a machine for manufacturing bottles and other articles of glass, the combination of the fixed vertical axis A opening A¹, fan a⁹, hollow arm a², orifice a³, fixed A⁴ having central hold, ring A⁵, fixed upon axis A and provided with notch A⁶, stud a, on axis A, horizontal axis a¹, fly wheel a², gear and bevel wheels, horizontal disc B having supports bb; levers b¹, b², spring pin b³, cups C; concentric rods c¹, c²; lever c⁴, horizontal arm D; templets E E, journal F, blow pipe G, sockets H, cross head h¹ with projection h², helicoidal grooves round the axes of the templets, lever I, arms i, bronze ring K, all substantially as described and for the purpose set forth.

No. 56,264. Tubular Frame for Lanterns.
(Cadre tubulaire pour lanternes.)

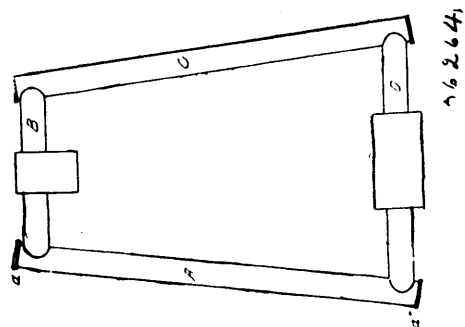

Alfred Huggins and Gilbert F. McKenzie, both of Monkton, Ontario, Canada, 14th June, 1897; 6 years. (Filed 11th February, 1897.)

Claim.—In a lantern in combination with the tubular frame screw caps A, A¹, A¹¹, A¹¹¹ placed at the angles thereof, substantially as shown and for the purpose set forth.

No. 56,265. Water Wheel. (Roue hydraulique.)

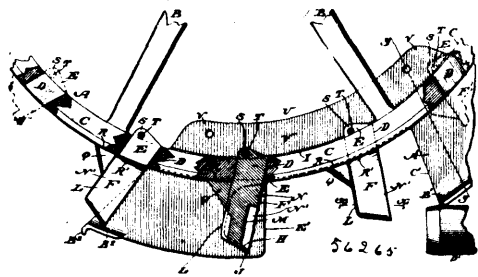

Daniel Hug, Colorado, U.S.A., 14th June, 1897; 6 years. (Filed 10th February, 1897.)

Claim.—1st. In a water wheel, a bucket having diverging chambers arranged side by side, the upper portion of said bucket having a V-shaped wall therein, the sides of which form the top of said chambers, the latter discharging at opposite sides of said bucket. 2nd. In a water wheel, a bucket having an inclined base, a plurality of chambers diverging therefrom, a V-shaped wall in the upper portion of said bucket, the sides of said wall forming the top of said chamber, the latter having their exits curved and contracted, and means for attaching said bucket to a water wheel. 3rd. The combination of a bucket provided with a shoulder or abutment Q, and a tongue E attached to said bucket, with a water wheel having in the rim thereof, a slot in which said tongue is inserted, and a pin passing transversely through said tongue, and having a bearing upon the inner periphery of said rim, said abutment being adapted to contract with the outer periphery of said rim. 4th. In a water wheel, a bucket having an inclined base H, the chamber K extending therefrom, the upper portion of said bucket being V-shaped and forming the top wall of said chambers K and the chambers P into which the latter chambers discharge said chambers P having a contracted outlet, a shoulder Q attached to the rear of said bucket, and a tongue S projecting from the latter. 5th. In a water wheel, a protector or casing, the same having attaching devices for a suitable support, an inwardly laterally extending portion, the same being continued downwardly, and an outwardly curved portion, the same being curved inwardly and thence continued laterally, and a portion of said protector adjacent the discharge nozzle being cut away. 6th. A protector for a water wheel consisting of two sections, each section having an upright flange V, the latterly and inwardly extending member X, the same being curved downwardly and having the outwardly curved portion Z, said protector extending thence downwardly and having the curvature A¹, and the lateral extension B¹, attached thereto. 7th. A protector for a water wheel, consisting of two sections, each section having an upright flange V, the laterally and inwardly extending members X, the same being curved downwardly and having the outwardly curved portion Z, the latter extending thence downwardly, and having the curvature A¹, the lateral extension B¹ attached thereto, one extremity of said casing having the downwardly deflected lip B², and means for holding said sections in position, a portion of the latter being cut away. 8th. The combination of a bucket provided with a shoulder or abutment Q, and a tongue or tenon E attached to said bucket and extending at an oblique angle to said abutment, with a water wheel having a slot in the rim thereof, through which said tongue passes, said slot being out of alignment with a radius of said wheel, and a pin passing through said tongue and resting transversely upon the inner periphery of said rim, said abutment being in contact with the outer periphery of said wheel. 9th. In a water wheel, a bucket having a plurality of diverging chambers, the upper portion of said bucket having a V-shaped wall therein, the sides of which wall assist in forming said chambers, which latter discharge at opposite sides of said bucket. 10th. In a water wheel, a bucket having a suitable base, a plurality of chambers diverging therefrom, a V-shaped wall in the upper portion of said bucket, the sides of said wall forming the top of said chambers, and means for attaching said bucket to a water wheel. 11th. In a water wheel, a bucket having a lower chamber provided with a uniform curvature and flaring sides, in which the incoming fluid is first received, a frog provided with overhanging edges located above said chamber, and a plurality of diverging outlet chambers, a wall of each chamber being formed by said frog. 12th. In a water wheel, a bucket consisting of the chamber 4, provided with the unbroken curved rear wall 2, the outwardly flaring sides 3, the frog 5 located above the latter, provided with the overhanging edges 7, the chambers 9 into which said chamber 4 discharges, said chambers having the outwardly flaring walls 10 and 11. 13th. In a water wheel, a bucket composed of a lower chamber, a plurality of diverging chambers above said lower chamber, and a frog, the above parts being proportioned and arranged in respect to each in substantially the manner described.

No. 56,266. Combination Cans and Openers. (Boîte de fer-blanc et appareil à les ouvrir combinés.)

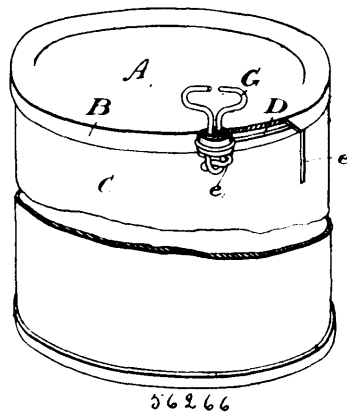

John Henry Stephens, Peterborough, Ontario, Canada, 14th June, 1897; 6 years. (Filed 8th February, 1897.)

Claim.—1st. In combination the can provided with an annular shoulder, a lid or cover provided with a depending flange closely encircling the shoulder, a wire ring resting upon the shoulder and having its free ends extending downwardly past the flange of the lid or cover so as to lie close to the can, and a ring of solder extending between the bottom of the flange and the shoulder and beneath the wire ring as and for the purpose specified. 2nd. In combination the can provided with an annular shoulder, a lid or cover provided with a depending flange closely encircling the shoulder, a wire ring resting upon the shoulder and having its free ends extending downwardly past the flange of the lid or cover so as to lie close to the can, a ring of solder extending between the bottom of the flange and the shoulder and beneath the wire ring and a lever key having an opening in the bottom thereof into which a depending end of the wire ring is designed to be inserted and around which bottom the wire and flange is designed to be wound, as and for the purpose specified.

No. 56,267. Coal Recorder for Railways. (Registre à charbon pour chemins de fer.)

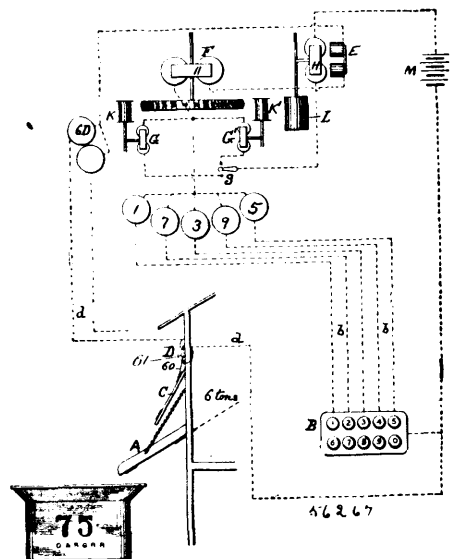

Frank A. Walters, Denver, Colorado, U.S.A., 14th June, 1897; 6 years. (Filed 28th January, 1897.)

Claim.—1st. The improved storage and recording system comprising the receptacles, chutes, or storage devices of determinate capacity, means for discharging the same, time recording mechanism, recording mechanism for the capacity, symbol, or other distinguishing feature, of the said receptacles, chutes or storage devices, and means for actuating both the said recording mechanisms when each of the said receptacles, chutes, or storage devices is discharged, substantially as set forth. 2nd. The improved stor-

age and recording system comprising the receptacles, chutes or storage devices of determinate capacity, means for discharging the same, time recording mechanism, recording mechanism for the capacity, symbol, or other distinguishing feature of the said receptacles, chutes or storage devices, and means for actuating both the said recording mechanism when each of the said receptacles, chutes, or storage devices is discharged, and recording mechanism for arbitrary symbols to indicate the party discharging the same, whereby record may be made of the time of discharge, the storage device or capacity discharged, and the party so discharging it, substantially as set forth. 3rd. In combination with two or more chutes or receptacles and means for severally discharging the same, the same chutes or receptacles being rated, or distinguished by capacity, arbitrary symbol or other distinguishing feature, time recording mechanism for the said chutes or receptacles, operating connections for the said time recording mechanism actuated by the discharge of each said chute or receptacle, recording mechanism for each said capacity, symbol or other distinguishing feature, individual operating connections therefor each acting upon the discharge of the corresponding chute or receptacle and other recording mechanism for the number, symbol, or other distinguishing feature of the engine or party opening or discharging the said chute or receptacle, substantially as set forth. 4th. In combination with two or more chutes or receptacles and means for severally discharging the same, the same chutes or receptacles being rated or distinguished by capacity, arbitrary symbol or other distinguishing feature, time recording mechanism common to all the said chutes or receptacles, operating connections for the said time recording mechanism actuated by the discharge of each said chute or receptacle, recording mechanism for each said capacity, symbol, or other distinguishing feature, and the individual operating connections therefor each acting upon the discharge of the corresponding chute or receptacle, substantially as set forth. 5th. In combination with two or more chutes or receptacles and means for discharging the same, the said chutes or receptacles being rated or distinguished by capacity, arbitrary symbol, or other distinguishing feature, a recording mechanism for each said capacity, symbol or distinguishing feature, individual operating connections therefor, each automatically actuated upon the discharge of the corresponding chute or receptacle, and other recording mechanism for the number or other distinguishing symbol, of the engine or party discharging such chute or receptacle, substantially as set forth. 6th. An electrically operated recording mechanism, an electric circuit and source of energy therefor, and an apron or other relatively moving body, in combination with a circuit controller containing the following elements: a movable contact actuated by the motion of the said relatively moving body and connected with the said circuit, a co-operating contact also connected with the said circuit, a spring for separating the said contacts, and a release for the said spring also actuated by the motion of the said body, whereby a single movement of the said body may both open and close the said contacts and control the said circuit and recording mechanism, substantially as set forth. 7th. In combination in a recording device, actuated by a key, the key provided with record making projections 86, the electric contacts actuated by the said projections, the insulating plates 84 with spaces between for the passage of the said projections, and means for preventing the turning of the key in a reverse direction, substantially as set forth. 8th. In combination in a recording device, actuated by a key, a set of keys therefor each provided with a projection or head 88, a ratchet 89, engaging the said head of the key, a pawl for the said ratchet, and means for preventing the withdrawal of the key when partly turned, substantially as set forth.

No. 56,265. Step-Ladder. (Echelle à marches.)

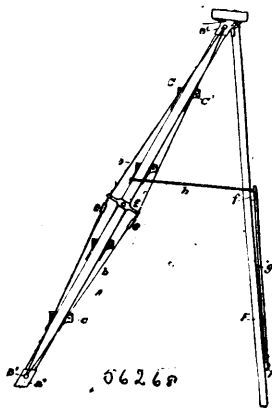

Albert Burnham Maguire, Stratford, Ontario, Canada, 14th June, 1897; 6 years. (Filed 18th January, 1897.)

Claim.—1st. In a step-ladder, the combination, with front legs provided with steps, of lateral projections on the upper and lower end portions of the said legs, twisted wire trusses looped over the

said projections and provided with means for tightening them, and bridges supporting the middle portions of the said trusses, substantially as set forth. 2nd. In a step-ladder, the combination, with front legs provided with steps, of trusses formed of twisted wires connected to the upper and lower end portions of the said legs, and bridges supporting the middle portions of the said trusses, substantially as set forth. 3rd. In a step-ladder, the combination, with front legs provided with steps, of rear legs pivoted to the front legs and provided with a brace at about the middle of their length and a bail pivoted to the front legs, passing around the rear legs and resting on the said brace, substantially as set forth.

No. 56,269. Blast Process for Engraving.

(*Procédé pour graver*)

Theodore Truchelut, Paris, France, 14th June, 1897; 6 years. (Filed 14th January, 1897.)

Claim.—The herein before described process for engraving, consisting of the projection by blasting mixture of an abrading powder and a solvent chemical, or of a simple or a compound substance capable of acting mechanically by abrasion and chemically by solution upon the surface to be engraved.

No. 56,270. Peroxide of Manganese and Carbon Electrodes. (Péroxyde de manganèse et électrode de carbone.)

Albrecht Heil, Frankish, Crumbach, Germany, 14th June, 1897; 6 years. (Filed 7th January, 1897.)

Claim.—The method of producing peroxide of manganese and carbon electrodes, which consists in reducing these electrodes before use, in an electrolyte (that contains chlorine but is free from nitrogen) by the action of an electric current from a separate or external source, and in then converting the said electrodes into chlorine compounds by reversing the current, substantially as herebefore described.

No. 56,271. Elastic Tire for Vehicle Wheels.

(*Bandage élastique pour roues de voitures.*)

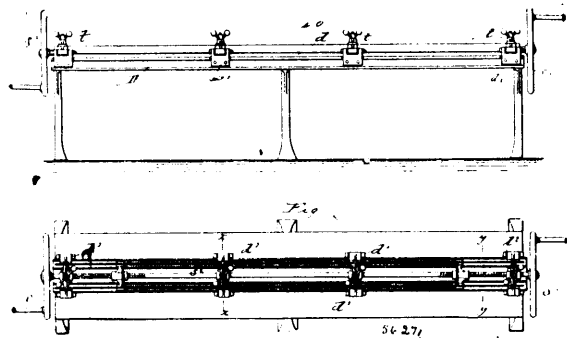

Rudolf Edward Cunf-Pierron and Isidor Klein, both of Vienna, Austria, 14th June, 1897; 6 years. (Filed 15th February, 1897.)

Claim.—1st. An elastic tire consisting of a series of compressed plates or discs set up on end around the rim of a wheel, coinciding perforations in said plates or discs, a securing band or bands passing through such perforations, and means for securing the ends of such band or bands and means to secure the tire to the wheel rim. 2nd. An elastic tire consisting of a series of compressed plates or discs set up on end around the rim of a wheel, irregular perforations in said discs for the purpose specified, coinciding perforations in said discs, a securing band or bands passing through said coinciding perforations, means for securing the ends of said band or bands, and means to secure the tire to the rim of a wheel. 3rd. An elastic tire consisting of a series of segments, each segment being formed of a number of coinciding discs having coinciding slots and irregular perforations, said discs being compressed together to form said segments, means to secure said segments together and means to secure the same to the rim of a wheel. 4th. The combination of a longitudinally-divided mould having a stationary part and a hinged part, means for securing said parts together, a detached stem having a foot plate to fit inside at the bottom of the mould, said stem being adapted to receive the plates forming the tire segments as specified, a closure plate to said stem capable of moving thereon, and having means to arrest a return movement when required and means to press said plate down on the inserted discs. 5th. The combination of a longitudinally-divided mould having a stationary part and a hinged part, means for securing said parts together, a detachable stem having foot plate to fit inside said mould, and adapted to receive the discs forming the tire as specified, a closure plate to said stem consisting of upper and lower plates *p*, *p*¹, pawls *q*, *q*¹, between said plates to engage teeth on said stem, a plunger *M*¹ having boring *l*¹, a radially mounted arm *n*¹ to carry said plunger, and means to force said plunger into the mould. 6th. The combination with a suitable support, of parallel bars *d*, shaped as described, a spindle intermediate

said bars and having oppositely-threaded ends and nuts travelling on said ends and having portions running in the bars *d*. 7th. The combination with a suitable support, of parallel bars *d*, shaped as described, a spindle intermediate said bars and having oppositely-threaded ends and nuts travelling on said ends and having portions running in the bars *d*, and means as described for maintaining the discs or plates in position while being compressed. 8th. The combination of a pair of pivoted levers having bifurcated jaws for the purpose specified and perforations in said jaws, and means as described for operating the levers in the manner and for the purpose specified. 9th. The combination of a suitable support, of a rail *r*, a vertically movable plunger and a grooved roller carried by the latter and co-operating with the rail *r*, as described. 10th. The combination of a suitable support, a rail *r*, a vertically movable plunger and a grooved roller carried by the latter and co-operating with the rail *r*, and means as described for moving the rail longitudinally beneath the roller.

No. 56,272. Knitting Machine. (Machine à tricoter.)

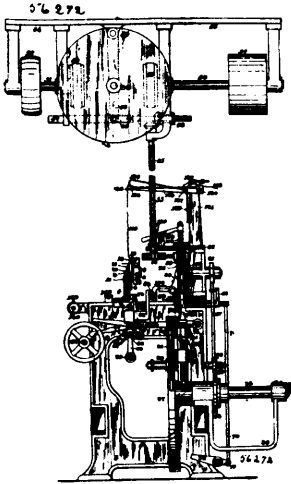

Richard Challands, Frederick William Pare and James Hill Smith, all of Nottingham, Nottingham County, England, 14th June, 1897; 6 years. (Filed 30th December, 1896.)

Claim.—1st. In straight and parallel bar latch needle knitting machines, the combination of the needles 1, means controlling the number of needles in work, the knitting cam 11 and mechanism whereby the length of the traverse of the knitting cam is varied substantially as set forth. 2nd. In straight and parallel bar latch needle knitting machines the combination of the needles 1, means controlling the number of needles in work, the knitting cam 11, mechanism for operating the said cam and mechanism worked by the said cam operating mechanism whereby the traverse of the cam is varied substantially as set forth. 3rd. In straight and parallel bar latch needle knitting machines the combination of the needles 1, means controlling the number of needles in work, the knitting cam 11, the driving mechanism, whereby the length of the traverse or movement of the cam may be varied and mechanism whereby the number of traverses of the cam may be varied relatively to the speed of the driving mechanism, substantially as set forth. 4th. In straight and parallel bar latch needle machines the combination of the needles 1, means which control the number of needles in work, the knitting cam 11, the crank wheel 27, and connections and means for adjusting the crank pin 29 of the said wheel at different distances from its centre whereby the extent of the movement of the cam is varied substantially as set forth. 5th. In straight and parallel bar latch needle knitting machines the combination of the needles 1, the means which control the number of needles in work, the knitting cam 11, a crank wheel 27 and connections whereby the cam is driven, the crank pin 29 of the wheel being radially adjustable, and automatic mechanism for changing the position of the crank pin whereby the amount of movement imparted to the cam may be varied substantially as set forth. 6th. In straight and parallel bar latch needle knitting machines the combination of the needles 1, the means which control the number of needles in work, the knitting cam 11, means whereby the length of the traverse of the cam may be varied, comprising a crank wheel 27 with a radially adjustable crank pin 29 and mechanism for automatically changing the position of the crank pin and mechanism for varying automatically the speed of the said crank wheel, substantially as set forth. 7th. In straight and parallel bar latch needle knitting machines the combination of the needles 1, means which control the number of needles in work, the knitting cam 11, a crank wheel with a fixed axle and connections whereby the cam is driven and means for automatically adjusting the position of one or both of the connecting link axles on the intermediate lever 23 relatively to the fulcrum of the same whereby the extent of the movement of the cam is

varied substantially as set forth. 8th. In straight and parallel bar latch needle knitting machines the combination of the needles 1, the means which control the number of needles in work, the knitting cam 11, a crank wheel and connections whereby the cam is driven, the position of one or both of the connecting link axles on the intermediate lever 23 being automatically adjustable relatively to the fulcrum, and automatic mechanism for changing the position of one or both axles on the intermediate lever whereby the amount of the movement imparted to the cam may be varied substantially as set forth. 9th. In a straight and parallel bar latch needle knitting machine, the combination of needles 1, means which control the number of needles in work, the knitting cam 11, means whereby the length of the traverse of the knitting cam may be varied comprising a crank wheel with a fixed crank pin and an intermediate lever 23 upon which one or both of the connecting link axles are adjustable relatively to the fulcrum, mechanism for automatically changing the position of the said axles, and mechanism for varying the speed of the said crank wheel substantially as set forth. 10th. In straight bar latch needle knitting machines, the combination of the needles 1, thread carriers 12, 13, knitting cams 11, producing two courses for each traverse of the same, and an expanding crank 27 driving the said knitting cams, constructed, arranged and operating substantially as herein described with reference to the accompanying drawings and for the purpose herein set forth. 11th. In straight bar latch needle knitting machines, the combination of the needles 1, thread carriers 12, 13, knitting cams 11, producing two courses at each traverse of the same, an expanding crank 27, driving the said cams and lifters 86, slides 92, and plates 95 for raising additional needles into work and supporting them in that position, constructed, arranged and operating as herein described with reference to the accompanying drawings and the purpose herein set forth. 12th. In straight bar latch needle knitting machines, the combination of the needles 1, needle jacks 2, web holders 21, knitting cam 11, expanding crank 27, fashioning screws 85, and splicing thread carrier mechanism, constructed, arranged and operating substantially as herein described with reference to the accompanying drawings and for the purpose herein set forth. 13th. In straight bar latch needle knitting machines, the combination of an expanding crank 27, needle lifting and supporting mechanisms, needles 1, and needle jacks 2, so formed that all needles in work may be raised and lowered at the same time, and a bar 73 for so moving the jacks, constructed, arranged and operating substantially as herein described with reference to the accompanying drawings and for the purpose set forth. 14th. In straight bar latch needle knitting machines, the combination of the needles 1, the needle jacks 2, the needle lifting and supporting mechanisms, fashioning screw mechanisms geared to a shaft 53, which is connected to a frictional driving mechanism and means whereby the fashioning screws, the above mentioned shaft and crank wheel screw 30 may be coupled together, constructed, arranged and operating substantially as herein described with reference to the accompanying drawings and for the purpose set forth. 15th. In straight bar latch needle knitting machines, the combination of the needles 1, needle beds 3, needle jacks 2, an expanding crank 27, fashioning screws 85, needle lifting appliances, splicing thread carriers 134 and 135, thread tension and take up levers 124 and star wheel pattern mechanism, constructed, arranged and operating substantially as herein described with reference to the accompanying drawings and for the purpose set forth. 16th. In straight bar latch needle knitting machines, the combination of the needles 1, thread carriers 12, 13, knitting cams 11, producing two courses at each traverse of the same, a crank with a fixed axle driving the said cams through an intermediate lever 23 upon which one or both of the connecting link axles are automatically adjustable relatively to the fulcrum of the lever substantially as herein described with reference to the accompanying drawings and for the purpose set forth. 17th. In a straight bar latch needle knitting machine, the combination of the needles 1, thread carriers 12, 13, knitting cams 11, producing two courses at each traverse of the same, a crank with a fixed axle driving the said cams through an intermediate lever 23 upon which one or both of the connecting link axles are automatically adjustable relatively to the fulcrum and lifters 86, slides 92 and plates 95 for raising additional needles into work and supporting them in that position, constructed, arranged and operating as herein described with reference to the accompanying drawings and for the purpose set forth. 18th. In straight bar latch needle knitting machines, the combination of the needles 1, needle jacks 2, web holders 21, knitting cams 11, producing two courses at each traverse of the same, a crank with a fixed axle driving the same through an intermediate lever 23, upon which one or both of the connecting link axles are automatically adjustable relatively to the fulcrum, fashioning screws 85, and splicing thread carrier mechanism constructed, arranged and operating substantially as herein described with reference to the accompanying drawings and for the purpose set forth. 19th. In straight bar latch needle knitting machines, the combination of a crank with a fixed axle driving the knitting cams 11, through an intermediate lever 23, upon which one or both of the connecting link axles are automatically adjustable relatively to the fulcrum, needle lifting and supporting mechanisms, needles 1, carried by needle jacks 2, so formed that all the needles in work may be raised and lowered at the same time, and a bar 73 for so moving the jacks constructed, arranged and operating substantially as herein described with reference to the accompanying drawings and

for the purpose set forth. 20th. In straight bar latch needle knitting machines the combination with the needles 1, the needle jacks 2, the needle lifting and supporting mechanisms, fashioning screw mechanism geared to a shaft 55, which is connected to the frictional driving mechanism, and a crank with a fixed axle driving the knitting cams 11, through an intermediate lever 23, upon which one or both of the connecting link axles are automatically adjustable with regard to the fulcrum, constructed, arranged and operating substantially as herein described with reference to the accompanying drawings and for the purpose set forth. 21st. In straight bar latch needle knitting machines, the combination of the needles 1, needle bed 3, needle jack 2, a crank with a fixed axle driving the knitting cams 11, through an intermediate lever 23, upon which one or both of the connecting link axles are automatically adjustable with regard to the fulcrum, fashioning screws 85, knitting cams 11, producing two courses at each traverse, needle lifting appliances, splicing thread carriers 134 and 135 and star wheel pattern mechanism constructed, arranged and operating substantially as herein described with reference to the accompanying drawings and for the purpose set forth. 22nd. In straight bar latch needle knitting machines, the combination of the needle bed 3, thread carriers 12, 13, web holders 21, needles 1, carried by centre jacks 2, needles carried by fashioning jacks 2 on both side of the centre jacks in each needle bed, knitting cam boxes 7, fitted with a cam plate 10, held in position by a removable key 14, and a screw 15, which has a nut in a block 16, sliding in a cam box and adjustable from the top of the cam box, the cam plate having attached to it inclines 11, for producing two courses at each traverse and thread carriers 12, 13, for feeding the needles raised by each incline as herein described with reference to the accompanying drawings and for the purpose set forth. 23rd. In straight bar latch needle knitting machines, the combination with the needles 1, needle bed 3, needle jacks 2, web holders 21, knitting cams 11, and thread carriers 12, 13, of fixed and sliding plates 92 and 95, for supporting the needles and jacks in work, the sliding plates being carried by needle lifter brackets 82, moved by fashioning screws 85 and fitted with springs 94, or spring catches 93, for supporting the last needle and jack raised into work as herein described with reference to the accompanying drawings and for the purpose set forth. 24th. In straight bar latch needle knitting machines, the combination with the needles 1, needle beds 3, needle jacks 2, web holders 21, knitting cams 11, thread carriers 12, 13, and fixed and sliding plates 95, 92, for supporting the jacks and needles in work, of needle lifters 86, fitted to slide in brackets 82, moved horizontally by bars 83, attached to the fashioning screws 85, and moved vertically by cam shaped slots 87, at the lower ends of the slide and a rod 88, carried by a shaft 90, which is oscillated in opposite directions alternately by two cams 155 and 156, each of which acts as a counter cam to the other cam as herein described with reference to the accompanying drawings and for the purpose set forth. 25th. In straight bar latch needle knitting machines, the combination with the needles 1, needle beds 3, needle jacks 2, knitting cam boxes 7, jack and needle supporting plates 92, thread carriers 12, 13, needle lifters 86, and cams 155, 156, actuating the same of a bar 93 carried and arranged so that all the needles in work can be raised when the knitting cams are at either end of their traverse and the fashioning needles be lowered out of work when the knitting cams are in the centre of their traverse as herein described with reference to the accompanying drawings and for the purpose set forth. 26th. In straight bar latch needle knitting machines, the combination with the needles 1, needle beds 3, needle jacks 2, thread carriers 12, 13, knitting cams 11, needle lifting and supporting mechanisms, of fashioning bars 83, carrying the needle lifting slide brackets 82, and connected to fashioning screws 85, geared together by an intermediate wheel 60 and intermittently rotated by ratchet mechanism thrown in and out of action by star wheel pattern mechanism as herein described with reference to the accompanying drawings and for the purpose set forth. 27th. In straight bar latch needle knitting machines, the combination with the needles 1, needles beds 3, needle jacks 2, knitting cams 11, thread carriers 12, 13, needle lifting and supporting mechanisms of a crank wheel 27, with a movable crank pin 29, carried by slides 28, and fitted with a screw 30, which is intermittently rotated by a star wheel 31, fitted thereto, and a lever 32, which is moved into the circular path of the star wheel by means of star wheel pattern mechanism as herein described with reference to the accompanying drawings and for the purpose set forth. 28th. In straight bar latch needle knitting machines, the combination with the needles 1, needle jacks 2, needle beds 3, knitting cams 11, thread carriers 12, 13, fashioning screws 85, needle lifters 86, and crank wheel 27, with an expanding crank pin 29, of a sliding spindle 100, carried, guided and rotated by a hollow spindle 96, which is geared to the intermediate wheel 60, actuating the fashioning screws and to a vertical shaft 55, geared to the friction drive, as herein described with reference to the accompanying drawing and for the purpose set forth. 29th. In straight bar latch needle knitting machines, the combination with the needles 1, needle jacks 2, needle beds 3, thread carriers 12, 13, knitting cams 11, expanding crank 27, fashioning screw 85, and a spindle 100, guided, carried and rotated by a hollow spindle 96, of an arrangement of gearing 56, 57, 58, by which the rotation of the vertical shaft 55, geared to the friction drive may be varied relatively the rotation of the fashioning screws 85, as herein described with reference to the accompanying drawings and for the purpose set forth. 30th. In straight bar latch

needle knitting machines, the combination with the needles 1, needle jacks 2, needle beds 3, thread carriers 12, 13, knitting cams 11, expanding crank 27, and fashioning screws 85, of a ratchet wheel 61, actuating the fashioning screws and connecting shaft to the vertical drive, and a clawker 67, continuously actuated but held clear of the ratchet wheel by a lever 69, which is connected to star wheel pattern mechanism and thrown into gear at or about the same time as the crank wheel screw 30 is, actuated as herein described with reference to the accompanying drawings and for the purpose set forth. 31st. In straight bar latch needle knitting machines, the combination with the needles 1, needle beds 3, needle jacks 2, knitting cams 11, thread carriers 12, 13, fashioning screws 85, fashioning screw actuating mechanism and an expanding crank 27, of a star wheel pattern, mechanism intermittently rotated by ratchet mechanism, a lever 164 held in contact with the star wheel 163, and also connected to a rocking shaft 72, carrying the lever 32, against which the star wheel 31, on the crank wheel screw 30 strikes and a lever 71, connected to another lever 69, which controls the relative positions of the fashioning screw ratchet wheel 61, and clawker 67, as herein described with reference to the accompanying drawings and for the purpose set forth. 32nd. In straight bar latch needle knitting machines, the combination with the needles 1, needle jacks 2, needle beds 3, knitting cams 11, thread carriers 12, 13, expanding crank 27, needle lifting and supporting devices, and fashioning screws 85, of splicing thread carriers, 134, 135, fitted to slide on a fixed rod 136, actuated by levers 142, 143, travelling with the knitting cams adjustably fixed tumbler cams 147, 148, and tumbler cams, carried by the fashioning bars 83, for disconnecting the splicing carriers and their actuating levers as herein described, with reference to the accompanying drawings, and for the purpose set forth. 33rd. In straight bar latch needle knitting machines, the combination of the needles 1, needle jacks 2, needle beds 3, knitting cams 11, thread carriers 12, 13, expanding crank 27, fashioning screws 85, work rollers 129, and splicing carriers 134, 135, with thread tension and take-up appliances, as herein described, with reference to the accompanying drawings, and for the purpose set forth. 34th. In straight bar latch needle knitting machines, the combination of the needles 1, needle jacks 2, needle beds 3, knitting cams 11, thread carriers 12, 13, expanding crank 27, needle lifting and supporting devices and fashioning screws 85, with a stop device comprising a pivoted lever 113, a cam or incline on the fashioning screw nut 84, a sliding catch and a spring 117 connected to the belt fork 107, as herein described with reference to the accompanying drawings, and for the purpose set forth. 35th. In straight bar latch needle knitting machines, the combination of the needles 1, needle jacks 2, needle beds 3, knitting cams 11, thread carriers 12, 13, expanding crank 27, fashioning screws 85, a spindle 100, for coupling the crank wheel screw 30 to the fashioning screws 85, with a safety lever 112, coupled to the belt fork rod and so shaped that when the belt is on the fast pulley the coupling spindle 100 cannot be lowered, and when the coupling spindle is lowered the belt cannot be moved on to the fast pulley as herein described, with reference to the accompanying drawings, and for the purpose herein set forth. 36th. In straight bar latch needle knitting machines, the combination of the needles 1, needle jacks 2, needle beds 3, knitting cams 11, thread carriers 12, 13, expanding crank 27, an intermediate lever 23, a vertical shaft 55, to a friction drive gearing actuating the same and the fashioning screws, a stop appliance and a safety appliance as herein described, with reference to the accompanying drawings, and for the purpose set forth. 37th. In straight bar latch needle knitting machines, the combination of the needles 1, needle jacks 2, needle beds 3, web holders 21, knitting cams 11, expanding crank 27, fashioning screws 85, fashioning bars 83, needle lifting and supporting appliances, a bar 73 for raising and lowering the needles and jacks 2, fashioning screw, actuating ratchet mechanism and connecting gearings, a star wheel pattern mechanism, knitting thread carriers 12, 13, splicing thread carriers 134, 135, and connected mechanism thread tension and take up appliances, a coupling spindle 100, stop and safety appliances work rollers 129, intermediate lever 23, and adjustable connecting link, arranged, constructed and combined, as herein described, with reference to the accompanying drawings and for the purpose set forth.

No. 56,273. Electrode. (*Electrode.*)

Albert E. Woolf, New York, State of New York, U.S.A., 14th June, 1897; 6 years. (Filed 13th February, 1897.)

Claim.—1st. An electrode for electrolysis of saline solutions consisting of an exposed thin plate of metal or metals of the platinum group, said plate being comparatively long from end to end, and narrow from its inner attached edge to its outer free edge, a connected conducting plate of base metal, the platinum compound plate being attached at its long edge to a similar edge of said conducting plate and having a long free edge, and a coating of insulating material applied to the surface of said conducting plate, and to the joint at the attached edges of said plates to protect them from the corrosive action of gases, substantially as described. 2nd. An electrode for electrolysis of saline solutions consisting of an exposed thin plate of metal or metals of the platinum group, said plate being comparatively long from end to end, and narrow from its inner attached edge to its outer free edge, a connected conducting plate of base metal, the platinum compound plate being attached at

its long edge to a similar edge of said conducting plate and having a long free edge, and a coating of insulating material applied to the

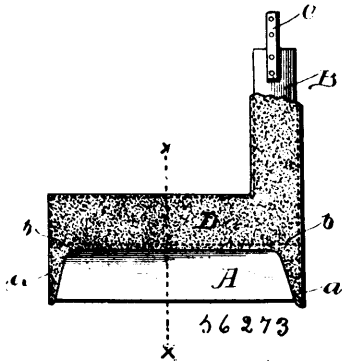

surface of said conducting plate, to the joint at the attached edges of said plate and to the ends of said platinum plate, to prevent the corrosive action of gases and give greater strength and rigidity to the electrode, substantially as described.

No. 56,274. Dehorner. (Instrument pour decorner.)

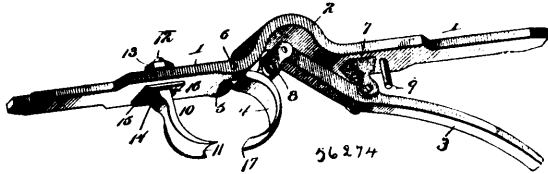

Benoni A. Bullock, Michigan, U.S.A., 14th June, 1897; 6 years. (Filed 26th February, 1897.)

Claim.—1st. In a dehorner, oppositely-curving cutters, the one having a curved edge and the other provided with an approximately U-shaped cutting edge, substantially as set forth and for the purpose described. 2nd. In a dehorner, a stock, a cutter pivoted to the stock, a lever fulcrumed to the stock and operatively connected with the pivoted cutter for actuating it, a second cutter to co-operate with the pivoted cutter, and means for adjustably connecting the second cutter with the stock, substantially as and for the purpose described. 3rd. In a dehorner, the combination of a pivoted cutter, a second cutter having a stem and a bracing shoulder at the base of the stem, a wedge interposed between the shouldered end of the adjustable cutter and its support, and means applied to the stem for securing the adjustable cutter in the required position, substantially as specified. 4th. In a dehorner, a stock having an arch between its ends, co-operating cutters at one side of the arch, one of the cutters being pivoted to the stock at one end of the arch, and an operating lever fulcrumed to the stock at the opposite side of the arch and having connection with the pivoted cutter, the arch affording clearance for the inner end of the said lever, substantially as specified. 5th. A dehorner comprising a bar having a portion between its ends bent to provide an arch, a cutter pivoted to the bar at one end of the arch, a second cutter having a threaded stem passing through an opening in the bar and having a bracing shoulder at the base of the stem, a slotted wedge interposed between the shouldered end of the adjustable cutter and the bar for properly positioning the cutter, securing means applied to the stem of the adjustable cutter for holding it in place, an operating lever fulcrumed to a stud provided on the bar at the opposite side of the arch, a link connecting the inner end of the lever with the pivoted cutter, and a stop for limiting the inner movement of the lever, substantially as set forth.

No. 56,275. Matrix Bar or Plate and Method of Making the Same. (Barre de matrices ou plaques et méthode de fabrication.)

Alexander S. Capehart, Bismarck, North Dakota, U.S.A., 14th June, 1897; 6 years. (Filed 4th March, 1897.)

Claim.—1st. A matrix for a line casting machine, consisting of a flat hard metal plate containing a soft metal stratum and cutaway at the edge to form an open-side recess and expose a part of the soft metal stratum in which the intaglio character is formed, substantially as and for the purposes described. 2nd. A matrix bar or plate having means by which it may be mechanically handled in a line casting machine, and composed of hard and soft metal strata laid and held together by heat and pressure, with the hard metal outermost at the edges of the bar or plate, and the hard metal edge of the latter cutaway to form an open-side recess which exposes a part of the soft metal in which the intaglio character is formed, substantially as and for the purposes described. 3rd. A matrix bar or plate for a line casting machine, consisting of strata of hard and soft metals united by heat and pressure, with the hard metal outer-

most, and cutaway to form a recess, one or more, with open sides, exposing a part of the soft metal in which an intaglio character is

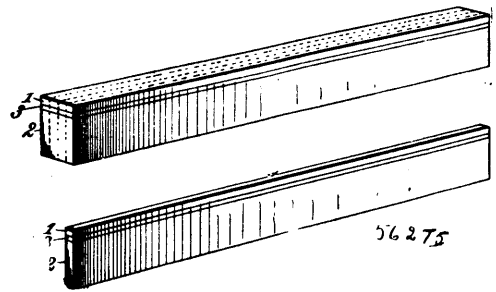

formed, substantially as and for the purposes described. 4th. A compound metal body for the manufacture of matrix bars or plates for line casting machines, consisting of hard metal strata and an intervening soft metal stratum, the strata being relatively disposed to present a continuous edge of hard metal constructed and adapted to be cut-away or removed to provide an open-side recess and expose a part of the soft metal stratum in which an intaglio character may be formed at the bottom of said recess, substantially as and for the purposes described. 5th. The method or process herein described of manufacturing a matrix bar or plate for a line casting machine, which consists in laying brass and copper strata together by heat and pressure, with the brass strata outermost, so that the edges of the bar or plate are composed of hard metal, and cutting-away or removing a portion of the hard metal edge to provide an open-side recess and expose a portion of the copper in which an intaglio character may be formed to lie at the bottom of the said recess, substantially as described. 6th. The method or process herein described of manufacturing a blank matrix bar or plate, which consists in superimposing layers of hard and soft metal, with the hard metal layers outermost, and then cuttingaway or removing a part of the hard metal at one edge of the blank to expose a part of the soft metal which constitutes a bottom wall to the recess and serves to receive the desired intaglio, substantially as described. 7th. The method or process herein described, of manufacturing matrix bars or plates for line casting machines which consists in laying strata of hard and soft metals together by heat and pressure, with the hard metal strata outermost, dividing such compound metal into blanks of the desired form or shape, cuttingaway or removing portions of the hard metal edges of the blanks to expose portions of the soft metal which constitutes bottom walls of the recesses thus formed, and forming intaglio characters in the soft metal at the bottoms of the recesses, substantially as described.

No. 56,276. Type Line Casting Machine.

(Machine pour couler les barres de caractères.)

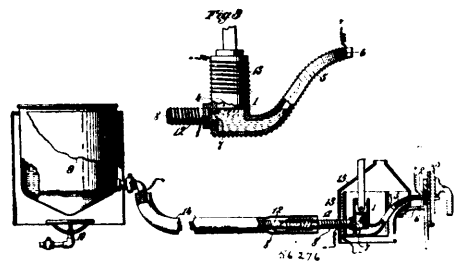

Alexander S. Capehart, Bismarck, North Dakota, U.S.A., 14th June, 1897; 6 years. (Filed 4th March, 1897.)

Claim.—1st. The combination with the mold of a type-line casting machine, constructed to cast a printing bar bearing a line of relief characters, of an electrically heated casting-pot co-operating with the mold, means for causing metal to flow from the casting-pot into the mold, a melting-pot arranged remote from said casting-pot, and an electrically heated conduit leading from the melting-pot and communicating with the casting-pot. 2nd. The combination with the mold of a type-line casting machine, constructed to cast a printing bar bearing a line of relief characters, of an electrically heated casting-pot having a delivery mouth to close one side of the mold and introduce metal thereinto, means for displacing the metal in the pot and forcing it therefrom into the mold, a melting-pot arranged remote from the casting-pot, and an electrically heated conduit leading from said melting-pot and communicating with said casting-pot. 3rd. The combination with the mold of a type-line casting machine, constructed to cast a printing bar bearing a line of relief characters, of a casting-pot co-operating with the mold, a plunger for displacing the metal in the pot and forcing it to flow into the mold, a melting-pot arranged remote from the casting-pot, a conduit leading from the melting-pot and communicating with the casting-pot, and means for electrically heating said conduit and said cast-

ing-pot. 4th. The combination with the mold of a type-line casting machine, constructed to cast a printing bar bearing a line of relief characters, of an electrically heated casting-pot co-operating with the mold and having a lateral orifice in its side, a melting-pot arranged remote from the casting-pot, an electrically heated conduit leading from the melting-pot and communicating with the casting-pot through said lateral orifice therein, and means for displacing the metal in the casting-pot and forcing it to flow into the mold. 5th. The combination with the mold of a type-line casting machine, constructed to cast a printing bar bearing a line of relief characters, of an electrically heated casting-pot co-operating with the mold and having a lateral orifice in its side, a melting-pot arranged remote from the casting-pot, an electrically heated conduit leading from the melting-pot and connected with the lateral orifice of the casting-pot, and a plunger which opens and closes communication between said conduit and the casting-pot through said lateral orifice, and serves to force the metal into the mold. 6th. The combination of a mold, a casting-pot co-operating with the mold, a melting-pot arranged remote from the casting-pot, a conduit leading from the melting-pot and communicating with the casting-pot, and a plunger arranged in the casting-pot for displacing the metal therein and forcing it to flow into the mold. 7th. The combination of a group of line casting machines, having molds and electrically heated casting-pots co-operating with the molds, with a melting-pot having a plurality of electrically heated connections with the casting-pots of said line casting machines. 8th. The combination with the mold of a type-line casting machine, of a casting-pot having an electric heating device applied about its throat which delivers the molten metal into the said mold, a melting pot arranged remote from said casting-pot and a conduit leading from the melting-pot to the casting-pot, substantially as and for the purposes described.

No. 56,277. Device for Measuring Oats, etc.

(Appareil à mesurer l'avoine, etc.)

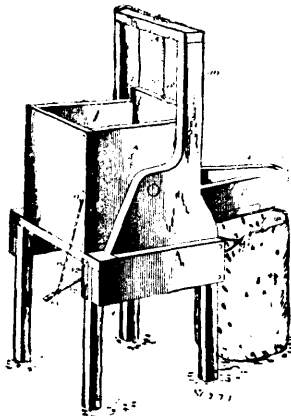

Anthony Daniel Besson, Forest House, Pennsylvania, U.S.A., 15th June, 1897; 6 years. (Filed 9th March, 1897.)

Claim.—A device of the class described, comprising the frame 1, provided with the guard 7, having integral securing spurs 8, 8, the notched plate 22, the standards 16, 16, and the cross brace 15, in combination with the measuring box 2 mounted on trunnions 3, 3, in said frame, and provided with the converging trough or chute 4, having the discharge orifice 6 in its forward end, the lever 17 fulcrumed in the lower end of a rod 13, pivoted to a staple secured to said box, and the sliding door 10 mounted in the front end of said box, and connected by a rod 13 to the cross brace 15, substantially as shown and described.

No. 56,278. Tobacco Cutting Machine.

(Machine à couper le tabac.)

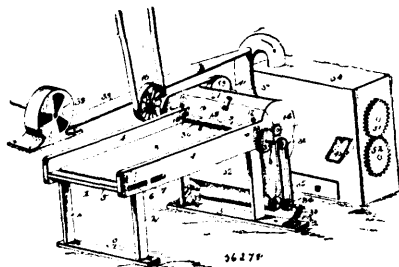

Nicholas P. Perkins, Roanoke, Virginia, U.S.A., 15th June, 1897; 6 years. (Filed 9th March, 1897.)

Claim.—1st. In a tobacco cutting machine, a cutting device comprising the rotating shaft 15, upon which is mounted series of discs

19 having radial cutting teeth 20, and a series of discs 17, which are thinner in cross-section than the discs 19 and are mounted on said shaft alternately with the former, and are formed with elongated knife edge cutting teeth 18 and intermediate shorter teeth 18', in combination with the stationary throat plate 24 having the rectangular slits 23, through which the elongated teeth 18 pass, and the straight edges 25, contiguous to the teeth 20 on the discs 19, and means substantially as described for continuously feeding the material to said cutting device, as and for the purpose set forth. 2nd. In a tobacco cutting and grading machine, the shaft 15, the cutting discs 17 and 19 mounted alternately on said shaft, the throat plate 24 having the slits 23 and the intermediate straight edges 25 contiguous to the discs 17 and 19 respectively, the roller 8 mounted in fixed bearings, the roller 5, and the endless apron 8' connecting said rollers, the roller 9 vertically adjustable in boxes 10-10 in the sides of the machine, in combination with the chambers 32 and 34', the air or blast pipe connecting them, the conveyer shafts 41-44, located in said chamber, the reticulated circular casings 42 and 43, encompassing said conveyer shafts 41-43 respectively, and the vibrating trough mounted in said chamber 34' between the said casings 42 43, substantially as and for the purpose set forth. 3rd. In a tobacco cutting machine, comprising a series of toothed cutting discs 17 and 19, and a throat plate 24 formed with slits 23, the combination with the feed roller 9, and the rollers 5 and 8 mounted in the same plane and connected by an endless feed apron 8', substantially as and for the purpose set forth. 4th. In a tobacco cutting machine comprising a feeding device substantially as described, the combination with the main shaft 15, upon which is mounted a series of cutting discs 17 formed with radial edged outer cutting teeth 18, and intermediate inner cutting teeth 18' and a series of alternating smaller cutting discs 19, formed with radial edged cutting teeth 20, substantially as and for the purpose set forth. 5th. In a tobacco cutting machine, means substantially as described for cutting the tobacco, in combination with a receiving and assorting chamber provided with stationary perforated cylindrical chutes 42 and 43, in which are located the rotating conveyer shafts 41 and 44, substantially as and for the purpose set forth. 6th. In a tobacco cutting and grading machine, the main shaft 15, provided with the toothed cutting discs 17 and 19, the slitted throat plate 23, 24, the endless feed apron 8' mounted on the rollers 5 and 8, and the feed roller 9, mounted in the same vertical plane as the roller 8, in combination with the chamber 32, the bottom of which is provided with a conveyer shaft 33, an air pipe leading from the fan 39, the pipe 37 leading to the chamber 34 in which is located the conveyer shafts 41-44, the perforated cylindrical chutes 42 and 43, and the inclined vibrating trough 46, substantially as shown and described. 7th. In a tobacco cutting machine, a main shaft, a polygonal faced drum mounted thereon, and a series of sectional toothed cutting discs secured to the polygonal faces of said drum, substantially as and for the purpose set forth.

No. 56,279. Ripping Scissors. (Ciseaux à fendre.)

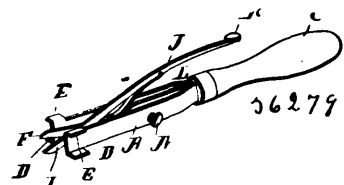

Charles Edwin Butler, New York, State of New York, U.S.A., 15th June, 1897; 6 years. (Filed 13th March, 1897.)

Claim.—1st. A ripping device consisting of two plates, guide and guard strips projecting therefrom, and a pair of scissors located between said plates, substantially as shown and described. 2nd. A pair of ripping scissors, consisting of two plates, a screw for regulating the distance between said plates, a pair of scissors located between said plates, and a handle in which said plates and scissors are secured, substantially as shown and described. 3rd. The combination of the plates A and B, secured with a suitable handle, a stationary blade also secured within said handle, a swinging blade pivoted to the first named blade, a spring for holding said swinging blade open, guide strips projecting from said plates, and guides also projecting from said plates, substantially as and for the purpose set forth. 4th. The herein described combination of the handle C, a stationary blade F, secured within said handle, spring plates A also secured within said handle, a screw M, passing through one of said plates and the blade and threaded into the opposite plate, a swinging plate pivoted to the first named blade, a spring I, adapted to hold the last named blade in its open position, a button K, for closing said blade, guide strips D projecting from the outer ends of the plates, and the guards E also projecting from said plates, all arranged substantially as and for the purpose set forth.

No. 56,280. Cigarettes and Methods of Making the Same. (*Cigarette et méthode de fabrication.*)

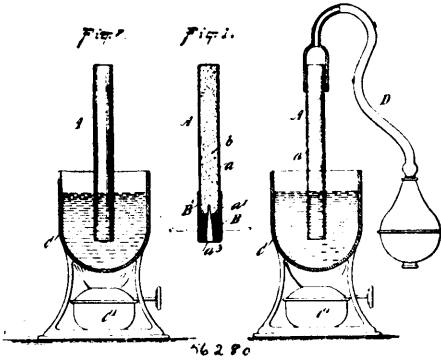

Louis Hernan Sondheim, New York, State of New York, U.S.A., 15th June, 1897; 6 years. (Filed 8th March, 1897.)

Claim.—1st. As a new article of manufacture, a cigarette having at one end an integral mouthpiece, the outer surface of which consists of a saliva proof cover, and the interior of which mouthpiece is formed of a portion of the tobacco filling within said cover, permeated and solidified into a cohesive mass by a binding substance, the solidified filling extending forward from the extreme end of the cigarette and forming a substantial backing for the saliva proof cover for a material distance therein, to sustain such cover against transverse pressure, said solidified part permitting the passage of smoke, substantially as described. 2nd. As a new article of manufacture, a cigarette having at one end thereof an integral mouthpiece, the surface of which consists of a saliva proof cover, and the interior of which is formed of a portion of the tobacco within said cover, permeated and solidified into a cohesive mass by paraffine or other wax, the solidified filling extending forward from the extreme end of the cigarette and forming a substantial backing for the saliva proof cover for a material distance therein, to sustain such cover against transverse pressure, said solidified part having a smoke passage, substantially as described. 3rd. As a new article of manufacture, a cigarette having a mouthpiece, consisting of a covering on the outside of the wrapper at the mouth end of the cigarette, and of a material portion of the bottom lying within said covered part of the wrapper, permeated and bound into a solidified, cohesive mass by a binding substance, the said interior mass forming a substantial backing for the wrapper and the outside covering against the transverse pressure exerted upon the same in smoking, said mass permitting the passage of smoke, substantially as described. 4th. As a new article of manufacture, a cigarette having its filling at one end solidified into a cohesive mass by a binding substance to form a mouthpiece, the solidified mass being provided with an aperture for the passage of smoke, and said mass which forms the walls of the aperture being of a greater depth than the diameter of the aperture at the inner end, whereby the tobacco will be prevented from falling out, and the saliva prevented from entering the cigarette, substantially as described. 5th. As a new article of manufacture, a cigarette having a material portion of its filling at one end combined with a binding substance to solidify same and form a well-defined barrier, said barrier having an aperture permitting the passage of smoke, substantially as described. 6th. The herein described method of forming mouthpieces on cigarettes, consisting in applying a binding substance to the filling at one end in such manner that said substance will permeate the filling and combine with same into a solidified mass to a material distance inward from said end to form a firm backing for the wrapper against the transverse pressure exerted, when the cigarette is held between the teeth, substantially as described. 7th. The herein described method of forming mouthpieces on cigarettes, consisting in applying to the filling at one end paraffine or other wax heated to a degree that it will readily permeate the filling and thereby effect a solidification of the filling for a material distance and thus form a firm backing for the wrapper against transverse pressure, substantially as described. 8th. The herein described method of forming mouthpieces on cigarettes, consisting in applying a binding substance to the filling at one end to form a substantial solidified barrier in the cigarette at said end, provided a saliva proof covering around such modified end, substantially as described. 9th. The herein described method of forming mouthpieces on cigarettes, consisting in applying a binding substance, to a material portion of the filling at one end to solidify same, shaping and smoothing said solidified end by pressure, substantially as described. 10th. The herein described method of forming mouthpiece on cigarettes, consisting in applying a binding substance to the filling at one end to solidify the same and form a well defined barrier for the purpose set forth, substantially as described. 11th. The herein described method of forming mouthpieces on cigarettes, consisting in applying a binding substance to the filling, at one end, to permeate and solidify the same, and form a well defined barrier for the purpose set forth, and subjecting said solidified end to pressure in the

presence of heat, substantially as described. 12th. The herein described method of forming mouthpieces on cigarettes, consisting in applying a binding substance to the filling at one end and drawing the same into the cigarette by suction, whereby a well defined barrier for the purpose set forth, will be formed, as described.

No. 56,281. Lawn Sprinkler.

(*Machine à arroser le gazon.*)

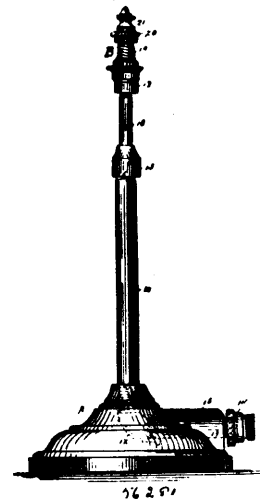

Charles A. Ashton, Piqua, Ohio, U.S.A., 15th June, 1897; 6 years. (Filed 8th March, 1897.)

Claim.—1st. In a lawn sprinkler, a spraying head, the same consisting of a base having a bore in two diameters, a helical closely coiled spring secured at its wider end to the said base above the enlarged portion of its bore, a cap secured to the contracted end of the said spring, and an apertured plug removably secured in the said cap, as and for the purpose specified. 2nd. In a lawn sprinkler, a spraying head, consisting of an apertured base having a flanged upper end, a coiled spring on the base within the flange thereof, and a cap having on its under side a flange surrounding the upper end of the spring and provided with an apertured plug, substantially as described.

No. 56,282. Clothes Wringer. (*Essoreuse de linge.*)

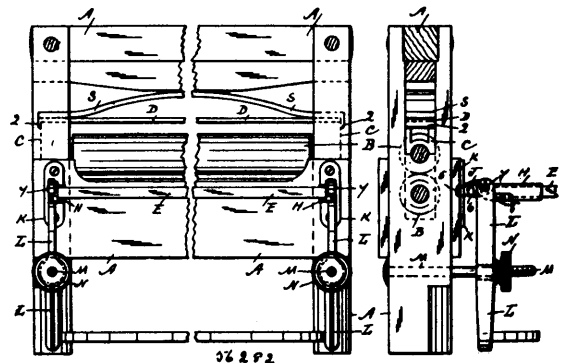

George B. Dowswell, Hamilton, Ontario, Canada, 15th June, 1897; 6 years. (Filed 8th March, 1897.)

Claim.—1st. A wringer of the character described, consisting of a frame with rollers, a flat horizontal bar resting upon the upper loose bearings thereof, end lips on said bar to retain said bearings in vertical and horizontal position in the frame and a controlling spring on said bar, substantially as described. 2nd. A wringer of the character described, consisting of a frame with rollers, a table in side arms pivoted to the pivotal links in said frame, the connected lever clamps on their threaded bars, having hand screws and the upper ends pivoted to said links at 3, and the lower ends of said clamps capable of inner pressure by means of lowering said table, and stops on arms of table to engage with the outer parts of the clamps when the table is in a level position, substantially as described.

No. 56,283. Duplex Tube. (Tube.)



Marion Chester Stone, Washington, Columbia, U.S.A., 15th June, 1897; 6 years. (Filed 5th March, 1897.)

Claim.—1st. As a new article of manufacture, an artificial straw consisting of a single strip of paper or other suitable material bent to form two tubes extending side by side. 2nd. As a new article of manufacture, an artificial straw consisting of a single strip of paper bent longitudinally in the form of an S, with its edges turned inward toward each other, and a water-proofing material applied to said straw.

No. 56,284. Car Fender. (Défense de chars.)

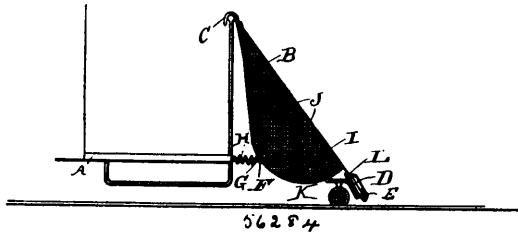

Norman Taylor Macferon, Allegheny, Pennsylvania, U.S.A., 15th June, 1897; 6 years. (Filed 15th March, 1897.)

Claim.—1st. The combination with the fender frame, of an axle curved as shown and pivotally mounted centrally and forwardly of the fender, a plate, rods supporting the same, and projections extending from the lower surface of said rods, substantially as and for the purpose specified. 2nd. The combination with the fender frame, of an axle curved as shown and pivotally mounted centrally and forwardly of the fender, a circular plate, rods connecting the same, the axle being flattened at its highest point and pivoted to said plate, substantially as herein shown and described. 3rd. The combination with the fender frame, of an axle curved as shown and pivotally mounted centrally and forwardly of the fender, a circular plate, rods connecting the same, the axle being flattened at its highest point and pivoted to said plate, and projections extending from the lower surfaces of said rods to limit the movement of the axle, substantially as herein shown and described.

No. 56,285. Music Leaf Turner and Holder. (Porte et tourne feuille.)

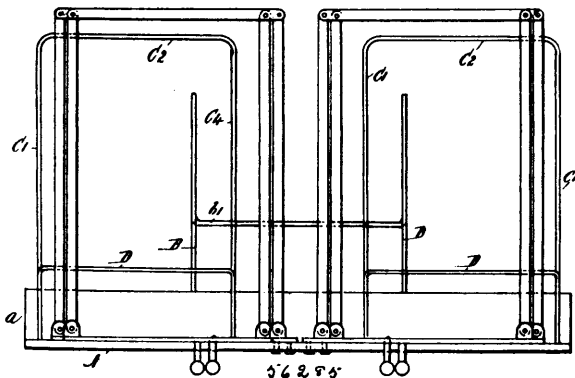

William Stevenson, Whitehall, New York, U.S.A., 15th June, 1897; 6 years. (Filed 19th March, 1897.)

Claim.—1st. A music holder and turner, comprising a base plate A, and means for supporting the same, said base plate being provided with a series of transverse slots near the middle thereof, and a corresponding number of frames which are adapted to support the sheets of music, each frame being provided with a pin which is adapted to pass through one of said slots, and each frame being also provided with an arm which is pivotally connected with the bottom thereof, and which extends outwardly, and by means of which the frames are turned, substantially as shown and described. 2nd. A music holder and turner, comprising a base plate A, and means for supporting the same, said base plate being provided with a series of

transverse slots near the middle thereof, and a corresponding number of frames which are adapted to support the sheets of music, each frame being provided with a pin which is adapted to pass through one of said slots, and each frame being also provided with an arm which is pivotally connected with the bottom thereof, and which extends outwardly, and by means of which the frames are turned, each of said slots in the base plate being also provided at its outer end with a circular enlarged opening through which a head connected with the pins secured to each frame is adapted to pass, and said base plate being also provided with a sliding plate which is adapted to close said circular opening, substantially as shown and described. 3rd. A music holder and turner, comprising a base plate A, and means for supporting the same, said base plate being provided with a series of transverse slots near the middle thereof, and a corresponding number of frames which are adapted to support the sheets of music, each frame being provided with a pin, which is adapted to pass through one of said slots, and each frame being also provided with an arm, which is pivotally connected with the bottom thereof and which extends outwardly and by means of which the frames are turned, each of said slots in the base plate being also provided at its outer end with a circular enlarged opening through which a head connected with the pins secured to each frame is adapted to pass, and said base plate being also provided with a sliding plate, which is adapted to close said circular opening, and said base plate being also provided with vertical and stationary loops or frames within which sheets of music may be placed, substantially as shown and described. 4th. A music holder and turner, comprising a base plate and means for holding the same in connection with the piano stand or other instrument, said base plate being provided with a transverse slot near the middle thereof, and a frame adapted to hold a sheet of music, the bottom portion of which is provided with a pin, which is adapted to enter said slots, and said bottom portion being also provided with an arm which is pivotally connected therewith, and which extends forwardly across said base plate and by means of which said frame is adapted to be operated, substantially as shown and described.

No. 56,286. Inhaler. (Inhaleur.)

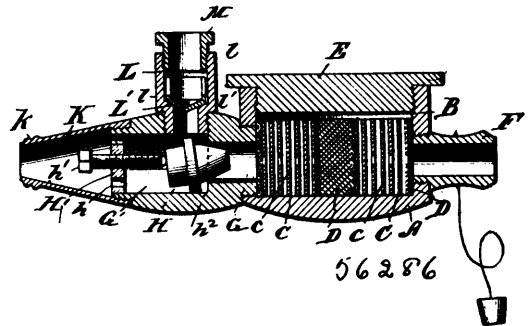

Charles Denison, Denver, Colorado, U.S.A., 15th June, 1897; 6 years. (Filed 19th March, 1897.)

Claim.—1st. In an inhaler, a medicament-chamber, an inlet at one end thereof, a valve-chest connected with the other end thereof, and provided with an exhaling opening, an adjustable outlet-valve within the valve-chest, and a suction-piece secured to the valve-chest. 2nd. In an inhaler and exhaler, the combination with a casing constituting a medicament-chamber, of an induction-tube secured to one end thereof, a valve-chest secured to the other end of the casing and provided with an exhaling-opening, a valve within the valve-chest, a suction-piece secured to the outer end of the valve-chest, and a threaded valve-adjusting device between the valve-chest and the suction-piece. 3rd. The combination with the valve-chest, and medicament-chamber, of an induction-tube secured to the latter, a detachable suction-piece, an adjustable valve within the valve-chest, a threaded adjusting device between the valve-chest and the suction-piece, and an exhaling-tube communicating with said valve-chest, and provided with an adjustable valve. 4th. The combination with the medicament-chamber, and valve-chest, of a suction-piece secured to the outer end of the valve-chest, an adjustable valve within the valve-chest, a threaded valve-adjusting device between the valve-chest and the suction-piece, and an exhaling-tube provided with means for regulating the exhalations. 5th. In an inhaler, a medicament-chamber, an inlet at one end thereof, a valve-chest connected with the other end thereof, and provided with an exhaling opening, an adjustable outlet-valve within the valve-chest, and a bifurcated nose-piece connecting with the outer end of the valve-chest.

No. 56,287. Spike and Drift Bolt Puller. (Arrache cheville et boulon.)

Lawrence C. Lounsbury and Alexander Campbell, both of Albion, Florida, U.S.A., 15th June, 1897; 6 years. (Filed 20th March, 1897.)

Claim.—The combination in a spike and drift bolt puller of the

foot-piece G, made with the heel-piece D, fitted with converging jaws B which move in slots y, the converging jaws being connected

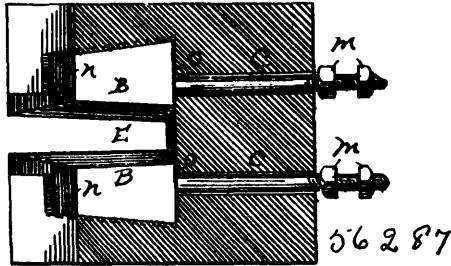

to and operated by a lever L which is pivotally connected to the foot-piece G.

No. 56,288. Machine for Making Nipples for Wheel Spokes. (*Machine pour faire les mamelons pour rails de voiture.*)

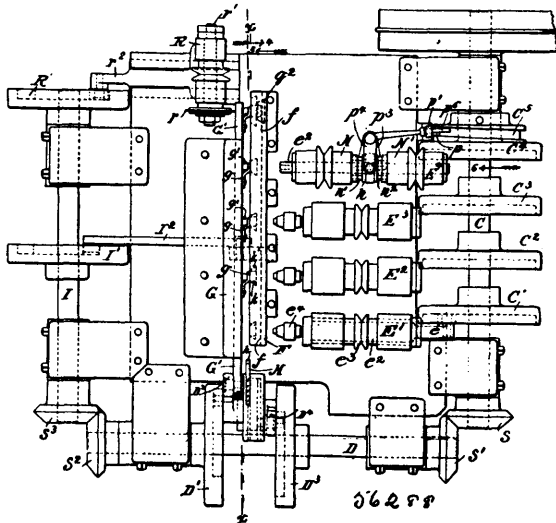

William G. Allen, Hartford, Connecticut, U.S.A., 15th June, 1897; 6 years. (Filed 20th March, 1897.)

Claim.—1st. In a nipple-making machine, the combination of a series of holders comprising each a fixed jaw and a positively operated movable jaw, said holders being set at suitable distance apart on a fixed support, a feed slide having a series of feeding jaws corresponding to the work holders, mechanism for reciprocating said feed-slide through a distance equal to that between adjacent work holders, and a series of cutting tools, for acting successively upon the blanks in said work holders, substantially as described. 2nd. The combination of a ledge horizontally slotted to form a passage for the blanks, and having lateral openings at intervals, a series of tools on reciprocating carriages, one opposite each of said openings, a series of work-holders comprising each a stationary jaw and a sliding jaw working in said ledge, a feed-slide parallel to said ledge, carrying feeding jaws corresponding to the work holders, and means for actuating said slide, tools and work holders, substantially as described. 3rd. The combination of a ledge horizontally slotted and having lateral openings from said slot at suitable intervals, a series of tools on reciprocating carriages, said tools being adapted to enter said openings to act on the work, a series of work holders, one at each opening, comprising each a stationary jaw and a movable jaw, mechanism for actuating the movable jaws positively, a second ledge parallel to the first, a feed slide working, a series of feeding devices thereon comprising each a stationary jaw and a spring-actuated jaw, and mechanism for operating said tools and slide, substantially as described. 4th. The combination, with a feed slide having a series of feeding jaws for feeding a blank step by step, comprising each a stationary jaw and a spring-actuated jaw, of a series of work holders on a stationary support, comprising each a fixed jaw and a movable jaw, the meeting faces of said jaws being in a different plane from the plane of feed movement of the blanks, a series of tools for operating successively upon the blanks, and mechanism for actuating said feed-slide, tools and work holders, substantially as described. 5th. The combination of a carrier having a spring-holding finger for delivering blanks one by one to the machine, a series of positively operated work holders the first of which takes the blanks from the carrier, a series of tools corresponding to the work holders, the first of which takes the blanks from the carrier, a series of tools corresponding to the work holders, and a feed

slide provided with a series of feeding jaws which carry the blanks from one work holder to the next, substantially as described. 6th. The combination of the work-holders arranged at suitable intervals apart on a stationary support and comprising each a stationary jaw and a movable jaw, the tools for operating successively upon the blanks in said work holders, the feed slide, a series of feeding jaws thereon, comprising each a stationary jaw and a jaw movable parallel with the movement of the work holding jaw, the meeting faces of the work holding jaws and feeding jaws respectively being in different planes, and mechanism for operating said tools, feed slide and work holders, substantially as described. 7th. The combination, with a series of work holders on a stationary support, and with a feed slide having feeding devices for carrying the blanks successively to the several work holders, of a chamfering and centering tool, a drill, a tapping tool, a die for flattening the sides of the blank and a slotting tool, said tools being arranged to act upon the blanks while in said work-holders, and mechanism for actuating said tools, feed slide and work holders, substantially as described. 8th. The combination, with suitable work holders, and with feeding devices for carrying a blank successively to said work holders, of tools for drilling the blank, a tapping tool, for threading the drilled blank, a reciprocating support for the spindle of said tool, two sleeves rotating in opposite directions on said spindle, mechanism for reciprocating said support, and clutch mechanism for connecting said spindle with one sleeve on the forward movement of said support and with the other sleeve on the return movement, substantially as described. 9th. The combination with work holders and with feeding devices for carrying a blank successively to said work holders, of tools for drilling and threading the blanks, a cutting tool or die for shearing the sides of the blanks at one end, while held in one of said work holders, and a cutter for notching the other end of the blank while in said work holder, substantially as described.

No. 56,289. Artificial Foot. (*Pied artificiel.*)

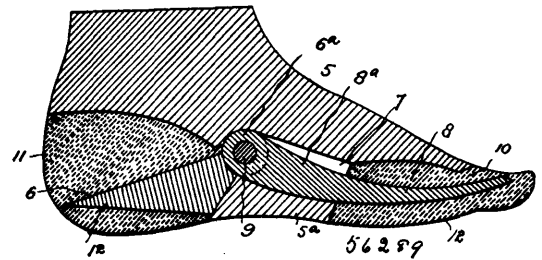

Paul A. Haberl, Denver, Colorado, U.S.A., 15th June, 1897; 6 years. (Filed 22nd March, 1897.)

Claim.—1st. An artificial foot comprising the body part and the independent heel and toe parts movably attached to the body part, and reinforced by some independent yielding substances placed both above and below the said movable parts, substantially as described. 2nd. An artificial foot comprising the body part and the independent heel and toe pieces movably attached to the body part, and reinforced by some yielding substance placed between the said pieces and the body part, substantially as described. 3rd. In an artificial foot, the combination of the body part and the independent heel and toe pieces movably hinged to the body part at a common point, substantially as described. 4th. In an artificial foot, the combination of the body part having a depending central part 5a, and the parts 6 and 8 hinged to the body part in such manner as to be capable of movement independently of each other and projecting respectively to the front and rear of the part 5a.

No. 56,290. Hammer. (*Marteau.*)

Albert R. Treat, Los Angeles, California, U.S.A., 15th June, 1897; 6 years. (Filed 22nd March, 1897.)

Claim.—1st. A nail holding attachment for hammers, consisting of a clamp, a body casing secured to said clamp and provided with a slot in one of its ends to receive a nail, jaws pivoted in the said casing and extending over the slot therein, the jaws being spring-controlled at their inner ends, as and for the purpose specified. 2nd. A nail holding attachment for hammers consisting of a clamp, a casing attached to the said clamp and extending at right angles therefrom, the said casing having a longitudinal slot in its outer end, and spring-controlled jaws pivoted within the casing, the free ends of the said jaws extending longitudinally over the slot in the casing, as and for the purpose specified. 3rd. A nail holding attachment for hammers consisting of a clamp, a casing attached to the rear end of said clamp, and extending beyond its forward end, the casing being at a right angle to the clamp, the said casing being provided with a slot in its forward end, spring-controlled jaws pivoted within the casing and extending over the slot therein, and a stop flange projected from the forward edge of the clamp over the said jaws, as and for the purpose specified. 4th. The combination, with a hammer and its handle, of a clamp secured to said hammer handle, a casing attached to the clamp at its forward end, which

casing extends beneath the head of the hammer along the front edge of the shank of the hammer, the casing being provided with a slot in

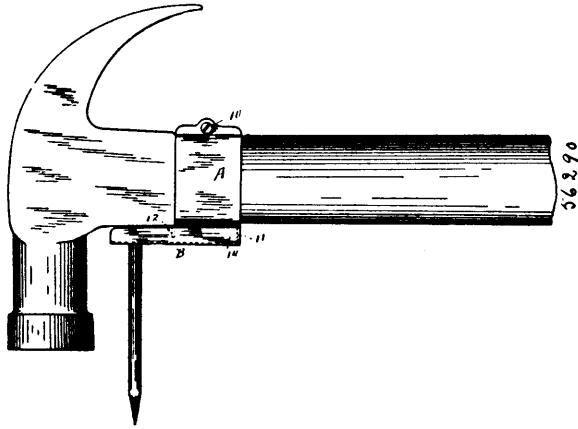

its forward end, and spring-controlled jaws pivoted within the casing, whereby the nail may be held by the jaws parallel with and below the head portion of the hammer, and the head of the nail may be brought between the jaws and the shank of the hammer, as and for the purpose specified.

No. 56,291. Bridge for Musical Instruments.

(Chevalet pour instruments de musique.)

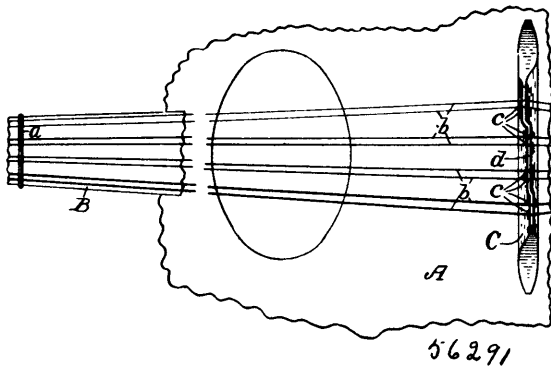

George Russell Stebbins, Rochester, New York, U.S.A., 15th June, 1897; 6 years. (Filed 22nd March, 1897.)

Claim.—1st. A bridge for a stringed musical instrument, having the bearings for the strings thereon formed forward or back of one another, each bearing being immovable and the whole bridge in a single piece, substantially as described and shown. 2nd. In combination with the nut and the frets of a stringed musical instrument, a bridge having immovable bearings for the strings, the bridge being in a single piece and the line of the string-bearings being irregular and out of parallel with the parts, substantially as specified.

No. 56,292. Register. (Registre.)

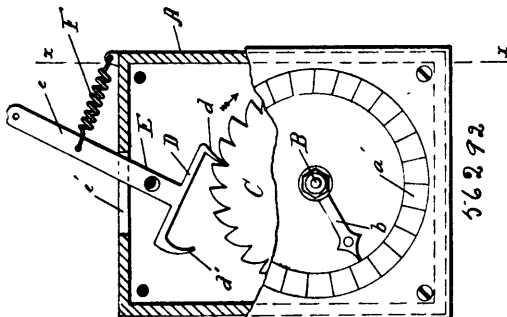

John C. Goodspeed, Nashwaak, New Brunswick, Canada, 15th June, 1897; 6 years. (Filed 23rd March, 1897.)

Claim.—1st. In a register, the combination, with a dial, of a shaft provided with a pointer and arranged centrally of the dial, an escapement wheel secured on the said shaft, and a pivoted escapement engaging with the said wheel, substantially as set forth. 2nd. In a register, the combination, with an escapement wheel, of a pivoted escapement engaging with the said wheel and provided

with a lever for operating it, and a spring for moving the said escapement in one direction, substantially as set forth. 3rd. In a register, the combination, with an escapement wheel, of a pin, an escapement pivoted loosely on the said pin and provided with an operating lever for operating it and also for rocking it out of engagement with the said wheel, and a spring for restoring the said escapement to its normal position substantially as set forth.

No. 56,293. Irrigator. (Appareil d'irrigation.)

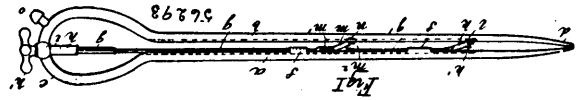

Frederic Clifford Tice, Roanoke, Virginia, U.S.A., 16th June, 1897; 6 years. (Filed 24th March, 1897.)

Claim.—1st. A combined dilator and irrigator, consisting of two hollow, separable arms united at one end, and having holes or perforations in their free ends and adapted to be supplied with and discharge an irrigating fluid, a rod mounted to slide on one of said arms, and means for connecting said rod with the other arm whereby the said arms may be directly separated or retracted without sliding movement of one arm upon the other, substantially as described. 2nd. In a combined dilator and irrigator, the combination of two hollow, separable arms united at one end and having holes or perforations in their free ends, and adapted to be supplied with and discharge an irrigating fluid, a sliding rod mounted on one of said arms, links connecting said rod with the other arm, and means for sliding said rod to effect the positive separation and approach of said arms, substantially as described. 3rd. In a combined dilator and irrigator, the combination of two hollow, separable arms united at one end and having holes or perforations in their free ends, and adapted to receive and discharge an irrigating liquid, one of said arms being provided with a longitudinal groove or channel, a rod mounted to slide in said groove, links connecting said rod with the other arm, and means for sliding or moving said rod to effect the positive separation and approach of said arms, substantially as described. 4th. In a combined dilator and irrigator, the combination of two hollow, separable arms united at one end and having holes or perforations in their free ends, and adapted to receive and discharge an irrigating liquid, one of said arms being provided with a longitudinal groove and clips bridging said groove, a rod mounted in said groove and under said clips, and means for connecting said rod with the other arm, whereby upon movement of said rod in opposite directions the arms will be separated and brought together respectively, substantially as described. 5th. In a combined dilator and irrigator, the combination of two hollow, separable arms having holes or perforations in one end of each of said arms and adapted to receive and discharge an irrigating liquid, a rod mounted on the inside of one of said arms, links connecting said rod with the other arm, and a screw-threaded sleeve for positively moving said rod to separate or bring together the said arms, substantially as described. 6th. In a combined dilator and irrigator, the combination of two hollow, separable arms having holes or perforations in one end thereof and adapted to receive and discharge an irrigating fluid, one of said arms being provided with clips or loops slotted longitudinally, a rod adapted to slide under said clips or loops, links connecting said rod with the other arm, and means for sliding said rod when confined under said clips or loops, substantially as described. 7th. In a combined dilator and irrigator, the combination of two hollow, separable arms having holes or perforations in one end and adapted to receive and discharge an irrigating fluid, a rod mounted to slide upon one of said arms, links connecting said rod to the other of said arms, one of said links remote from the end of said rod having a sliding connection with said rod and being shorter than the remaining link, substantially as described. 8th. In a combined dilator and irrigator, the combination of two hollow, separable arms united at one end and provided near said end with a fluid supply or inlet device, a rod mounted to slide upon one of said arms, an end link and an intermediate link connecting said rod with the other arm, the end link being of a greater length in proportion to its distance from the union of the arms in proportion to its distance from the union of said arms, substantially as described. 9th. A combined dilator and irrigator, comprising hollow, separable arms adapted to be supplied with and discharge an irrigating fluid independently of and also in conjunction with its dilating function, and means to separate said arms, consisting essentially of a longitudinally-movable rod arranged upon one of the arms and connected by movable joints with the other arm, substantially as described. 10th. A combined dilator and irrigator, comprising hollow, separable arms adapted to be supplied with and discharge an irrigating fluid independently of and also in conjunction with its dilating function, and means to separate said arms, consisting essentially of a longitudinally-movable rod, slotted clips upon one of the arms adapted to retain the rod while in use and permit its longitudinal movement and also adapted to admit of the ready removal or detaching of the rod for cleansing purposes, and links connected with said rod and connecting with the other arm, substantially as described.

No. 56,294. Reflecting Cap for Lamp Burners.
(*Réfecteur pour becs de lampes.*)

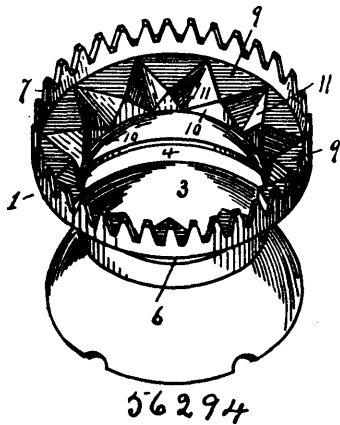

Benjamin F. Fowler and Fred T. Higgins, both of Minneapolis, Minnesota, U.S.A., 16th June, 1897; 6 years. (Filed 25th March, 1897.)

Claim.—1st. A cap for burners having a fixed combustion point, said cap being provided with an annular series of pyramidal projections arranged in the plane of the flame, each projection having a horizontal upper face and angularly-disposed side faces arranged approximately at angles of forty-five degrees with a radii of the cap, substantially as specified. 2nd. A cap for burners having a cavity to receive the burner, said cavity being partly closed at its top by a shield having an opening to register with the opening in the burner to which the cap is applied, and provided above the plain of said shield with an upwardly flared rim terminating in an upstanding flange 7, and an annular series of pyramidal projections 8 disposed within said flared rim and having upper, inner and lateral reflecting-faces, substantially as specified. 3rd. As a new article of manufacture, a reflecting-cap for burners having a bell-shaped or conical lower portion 2, an upwardly-convexed shield 3 provided with an opening to register with the wick-tube of a burner, an upwardly flared rim 6 terminating in a flange 7, and an annular series of pyramidal projections 8 arranged within said rim and having upper, inner, and lateral flat reflecting-faces intersecting to form the apices of the projections, said cap being of integral construction, substantially as specified. 4th. A cap for burners having a cavity to receive the burner, said cavity being partly closed at its top by a shield having an opening to register with the opening in the burner to which the cap is applied.

No. 56,295. Insect Destroyer.
(*Machine pour détruire les insectes.*)

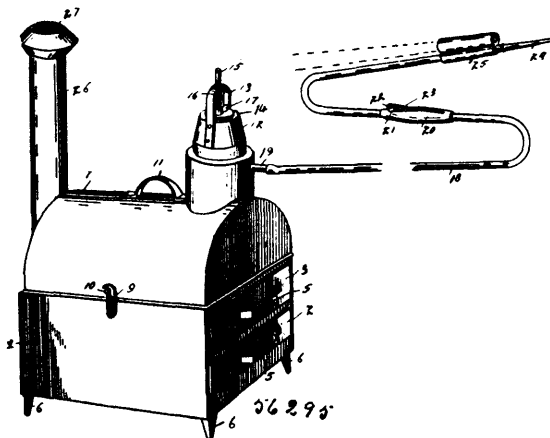

Richard Calvin Madden, Duster, Texas, U.S.A., 16th June, 1897; 6 years. (Filed 27th March, 1897.)

Claim.—In an insect destroyer, the combination with an open rectangular frame or body having longitudinal ledges upon its interior, and also having a smoke-stack communicating therewith, of longitudinally-sliding and removable trays or drawers having surrounding sides and constituting the fire-box and ash-pan of the device, the rear wall of the fire-box being apertured in line with the lower end of the smoke-stack to promote the draft, a removable steam-boiler of substantially semi-cylindrical form having its flat

face disposed downward and supported upon ledges of the main body or frame, pivoted hooks for holding the boiler in place, a flexible pipe communicating with the boiler and having a discharge-nozzle at its outer end, a metal socket or ferrule surrounding said pipe behind the nozzle and carrying a tapering socket adapted to receive the end of a handle, whereby the nozzle may be elevated and carried to any point, and a steam cut-off located intermediate the ends of the flexible pipe and comprising a metal sleeve surrounding said pipe, and a spring-arm attached at one end to said sleeve and carrying at its free end a plug which operates through an opening in the sleeve and serves to pinch the flexible pipe for closing the steam passage therein, all combined and arranged substantially as described.

No. 56,296. Net Float Turning Lathe.
(*Tour pour flotteurs de seines.*)

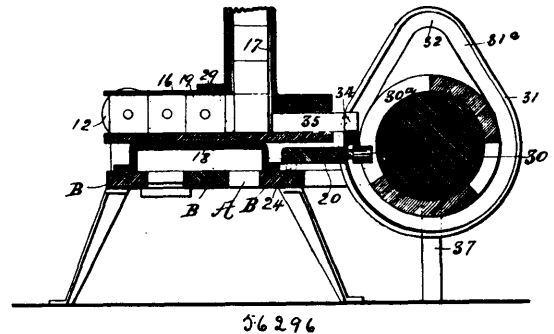

Herbert Smith, Enderby, British Columbia, Canada, 16th June, 1897; 6 years. (Filed 29th March, 1897.)

Claim.—1st. In a lathe for net-float turning, the combination of an oscillatory frame 20 arranged upon a suitable bed, of cylindered tubes secured in and forming a part of the said frame, of frames 25 arranged at each end of the first frame, the parallel portion thereof passing through the tubes in the first frame, and the parallel opposite sides of the frame 25 being provided with pulley-wheels 26^a, and means for throwing the said wheels backward, whereby the frames will be reciprocated, substantially as specified. 2nd. A lathe for net-floats having an oscillating reciprocating frame, in combination with a fixed frame 16 with a chute, arranged between augers on either side thereof, and cutter-heads arranged parallel thereto, of a portion of the frame 16 arranged to receive a block and oscillate to the said augers, and of means for oscillating the blocks to the revolving knives in the cutter-heads, as set forth. 3rd. In a lathe for turning and boring net-floats, the combination of an oscillatory frame having reciprocating frames arranged at each end thereof, of a chute for blocks having an oscillating portion, of cutter-heads arranged on either side of the said chute and portions of the oscillatory frame passing therethrough to engage the opposite ends of the blocks placed therein, and means for oscillating the said blocks against the knives in the cutter-heads, substantially as specified. 4th. In a lathe for making net-floats having a suitable frame to support the cutter-heads and augers suitably arranged thereon, the combination of an oscillating frame arranged upon a bed A, a chute rigidly fixed intermediately thereof and between the cutter-heads and augers, of a drum 30 lying parallel and in proximity to the bed A and oscillatory frame, a winding channel 30^a around the said drum, a projecting pin on the frame 20 having a spindle 20^b interposed in the said channel, and means for imparting slow motion to the said drum, whereby the frame on the bed A will be oscillated, substantially as set forth. 5th. In a net-float machine, the combination of an oscillatory frame arranged upon a bed, of reciprocating frames on either ends of the said oscillating frame, of a drum arranged at one side thereof, flanges on either side of the said drum, semi-elliptical projections on either side of the said flanges, projections 36 on each end of the edge of the drum and at an even plane with the elliptical portions, the said projections 36 engage wheels or rolls on the ends of the projecting frames whereby the shafts 27 on the opposite side of the oscillating frame will be thrown backwards at regular intervals, as set forth. 6th. In a machine for net-float making, a combination of reciprocating, oscillating frames arranged upon a bed, augers and cutter-heads arranged intermediately within the said frames, a chute for blocks having an oscillatory portion arranged at right angles to and between the said cutter-heads, of a drum having grooved flanges on its ends in proximity to one side of the bed and oscillatory frame, of a semi-elliptical deviation from the common radii in one side of the grooves, and at an even plane with the vertical portions in the channel 30^a, as 30^b in the said drum, of a cross-arm 34 projecting into the channels of the groove of the flanges on either end of the drum, a plunger or ram 35 secured to the cross-arm and extending into the rigidly fixed chute in the frame 16, and means for imparting slow motion to the said drum: whereby the plunger will be oscillated into the block chute in the frame 16, substantially as and for the purpose herein-before set forth.

which the outer ends of the said levers are forced apart, and the inner ends of said levers being adapted to enter the notches or re-

thereof, secured to the top of said sides, the oppositely disposed guides B secured to the inner faces thereof, the upper cross-head C

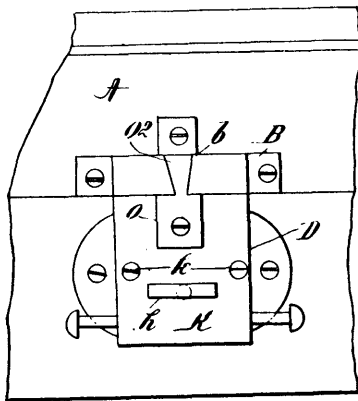

56299

cesses formed in the sides of that part which is secured to the upper sash, and the casing which is adapted to be secured to the lower sash being provided with a cross-head which is mounted between the outer ends of said levers, and which is adapted to hold said outer ends in the locked position, substantially as shown and described.

No. 56,300. Dump Wagon. (Wagon à bascule.)

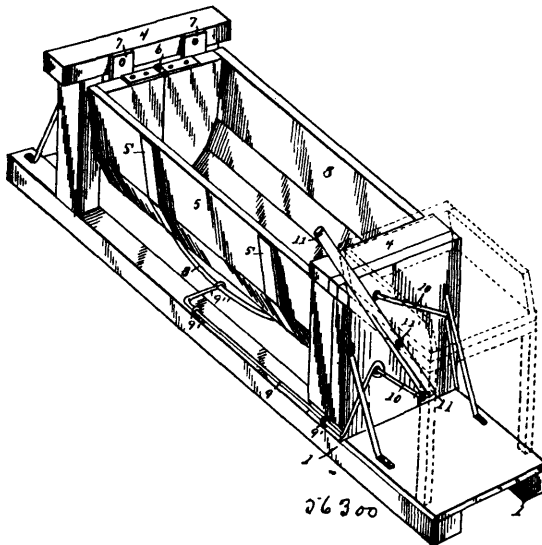

56300

William Henry Earle, Plainesville, Ohio, U.S.A., 16th June, 1897; 6 years. (Filed 17th April, 1897.)

Claim.—1st. A dump wagon consisting of a suitable frame work having uprights rising therefrom and suitable braces, the box sections pivoted in said frame, and means for opening and closing the lower edges of said sections, for the purpose set forth. 2nd. A dump wagon consisting of a suitable frame work having uprights rising therefrom, the box consisting of two sections hinged together and pivoted to said frame work, the seat at the forward end of said box and the lever for operating the sections of said box to open and close their lower edges, substantially as and for the purpose set forth. 3rd. A dump wagon consisting of a suitable frame work having uprights rising therefrom, the box consisting of two sections hinged together and pivoted by means of hangers to said frame work, the lever pivoted to the forward end of the box, the rock-shafts, links and bails connecting the sections of said box with said lever and all adapted to operate, substantially as and for the purpose set forth.

No. 56,301. Mechanical Movement for Drop Hammers, Rock and Deep Well Drills, etc. (Mouvement mécanique.)

John Augustus Hawthorn, Lancaster, Pennsylvania, U.S.A., 16th June, 1897; 6 years. (Filed 15th April, 1897.)

Claim.—1st. The combination in a mechanical movement with the framework having the sides A, the cross-piece A¹, with the rearwardly projected arm a² and the pivot pin A³ at the rear end

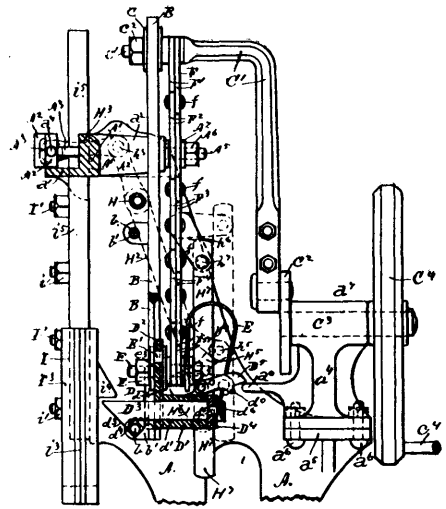

56301

and the lower cross-head D mounted on said guides, of the lazy-tongs rack as described, pivotally mounted on said pivot pin A³, having the lower end thereof pivoted to the cross-head D and the upper end to the cross-head C, with the mechanism provided to reciprocate the said upper cross-head, whereby the lazy-tongs rack will reciprocate the said lower cross-head over a much greater distance, substantially as described and for the purpose hereinbefore set forth. 2nd. The combination in a mechanical movement having a lazy-tongs rack pivot point at the top of the framework as shown, oppositely disposed cross-head guides supported by the sides of said framework, an upper and a lower cross-head mounted on said guides, a lazy-tongs rack as described mounted on said pivot point, having one end pivoted to the said upper cross-head, with mechanism provided to reciprocate said cross-head, and the other end pivoted to the said lower cross-head, with the lower cross-head D, having the rearward extension D¹, with the angular orifice d¹ through the body thereof, of the lift D³, having its shaft movable back and forth in said orifice, the upwardly and forwardly sloping face d³, and the downwardly projecting lip d⁴ at the forward end thereof, the cross-bar D⁴, with the guide-riding extremities d⁴ secured to the rear end of said shaft, and the means provided, such as the spring E⁵, to keep said bolt pressed forward, all substantially as described and for the purpose set forth. 3rd. In a mechanical movement, the combination with the lower cross-head supporting the lift-bolt D³, and the cross-bar D⁴ secured to the rear end of said bolt, having the upwardly projected plate D², and the angular orifice d² through the body of said plate, of the bolt E having the angular portion e³ in said orifice d², the shoulder e² against the rearward face of said plate D², the elastic packing E¹ above said angular portion e³ to fill said orifice d², the washer E² against said angular portion e³, and the nut E³ on the threaded portion e⁴ screwed home onto the back of said washer E², the lazy-tongs bars F⁵ on the cylindrical portion d⁵, the washer E⁴, the spring E⁶ and the washer E⁶ on the angular portion e⁶, and the nut E⁷ on the threaded end e⁷ screwed home onto said washer, with the bifurcated end of the spring pressing against the back of said cross-bar D², all substantially as described and for the purpose set forth. 4th. In a mechanical movement, in combination, the sides A, A, the cross-piece A¹ having the shelf a¹ with the orifice a², the grip-bar A² with the end pivot pins and nuts a⁴, the shaft H journaled through said sides, the hand lever H¹ having the upper extension h¹, and the lever H² having the upper extension h², the links H³, H³, by means of said pivot pins and nuts a⁴ connecting the said extensions h¹ and h² with the said grip-bar A², all substantially as described and for the purpose set forth. 5th. In a mechanical movement, in combination, the sides A, A, of the framework, the shaft H journaled through said sides, the hand lever H¹ and the connecting lever H², the outside lever-arm H⁵ and the inside lever-arm H⁶ both rigidly secured to the said shaft journaled through the intermediate sides A, the link H⁴ connecting the free end of said lever H² and the free end of said lever-arm H⁵, the parallel lever-arm h⁶ pivoted above the inside lever-arm H⁶, and the parallel guide-bar H⁷ pivoted to the free end of said lever-arm H⁶ and h⁶, all substantially as described and for the purpose set forth. 6th. In a mechanical movement, in combination, the rack-bar G, having the gear-teeth g and the vertical slots g¹ and g¹, the guide-pins G¹ and G¹ secured into a side A and passed through the said slots, and the plates g² and g² riveted onto said

pins, movably secured to the said sides, the pinion G^2 having the gear-teeth g^3 intermesh with the said teeth g , the shaft G^3 journaled through the adjacent side A of the framework, and having the inner end rigidly secured into the centre of said pinion, the hand-wheel G^4 rigidly secured to the outer end of said shaft, and the handle g^4 secured to the rim of said wheel, and the cam-shaped guide-plate G^5 having the offset straight edges g^6 and g^9 , and the incline plane g^7 joining said straight edges, rigidly secured to the said rack-bar, all substantially as described and for the purpose set forth. 7th. The combination in a mechanical movement with the cross-head D, having the rearwardly projecting arms D^1 , the shaft of the backwardly and forwardly movable lift-bolt D^2 within said arm, the cross-bar D^3 , having an extremity d^8 moving up and down on the cam-shaped guide G^5 , secured to the rear end of the shaft, the spring E^5 to keep said bolt pressed forward within said arm, and the upwardly projected ears d^7 at the rear end thereof, of the latch-lever D^5 , having its forward end pivoted between said ears and its rearward end projected beyond said cross-bar and adapted to ride thereon, the stop-hook d^9 projected from the under edge of said latch to drop behind said bar and hold said bolt, and the forwardly projected finger a^9 to lift said latch and release said bolt, with mechanism provided to reciprocate said cross-head, all substantially as described and for the purpose hereinbefore set forth. 8th. In a mechanical movement, in combination, the bars F^1 , F^2 , F^3 , F^4 and F^5 and the central pivot pins f^1 , all arranged and pivoted together as shown, the pairs F^0 and F^1 , having their free ends adapted for pivotal connection respectively with the lower and the upper cross-heads, and the pair F^2 , where they cross, for securing to the framework pivot, being longer above than below, all substantially as described and for the purpose set forth. 9th. In a mechanical movement, in combination, the sides A, with the brackets a^3 , the cross-piece A^1 , having the shelf a^1 with the vertical orifice a^2 and the arm a^5 , with the pivot pin a^6 , the bolts and nuts a , the standard A^4 having the shaft-bearing a^7 , and the forwardly projected finger a^9 , and the bolts and nuts a^6 , all arranged and secured in position to constitute the framework hereinbefore described.

No. 56,302. Fireplace Heater. (Chauffeur pour foyers.)

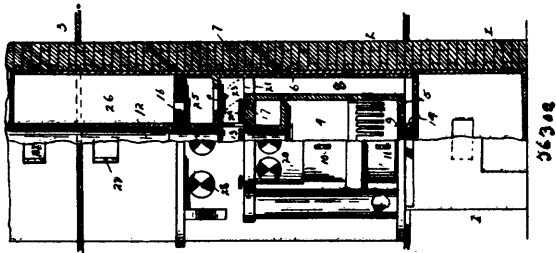

H Ezekiah Howe, Olean, New York, U.S.A., 16th June, 1897; 6 years. (Filed 3rd May, 1897.)

Claim.—1st. In a heater of the character described, the combination with the inner and outer walls, the side air passages, the chamber with which said passages communicate the chamber located above the same, and the dampers or registers therefor of the smoke-pipe having openings therein, and the dampers for opening and closing the same, substantially as described. 2nd. In a heater of the character described, the combination with the base, the side passages communicating with the room in which the heater is located, and the hot-air reservoir adapted to communicate with a room below the heater, and with a chamber above the heater provided with registers of the smoke-pipe communicating with a chamber provided with openings, the dampers for opening and closing said openings, the chamber above the same provided with registers, and the sliding damper for regulating the draft in the smoke-pipe, substantially as described.

No. 56,303. Rim Clamp for Wheels.

(Agrafe de jantes pour roues.)

Charles Schalles, Cortez, Colorado, U.S.A., 16th June, 1897; 6 years. (Filed 30th April, 1897.)

Claim.—1st. A rim clamp for wheels, the same consisting of a segmental body bar provided at about the centre of its length with a laterally extending arch forming a break in the face of the bar adapted for engagement with the rim of the wheel, clamps located upon the body bar on opposite sides of the arch, and lock levers adapted for shifting and locking the clamps in their shifted position, as and for the purpose specified. 2nd. A rim clamp for wheels, the same consisting of a segmental body bar having a lateral arch formed upon its ends, dividing the inner or contact face of the body bar, clamping yokes slidably connected with the body bar, adjusting screws carried by the said yokes, and lock levers adapted for locking and shifting the yokes, as and for the purpose specified. 3rd. A clamp for the rim of vehicle wheels, the same consisting of a segmental body bar provided with an outward extension adapted to receive a saw and forming a space in the contact face of said body

bar, clamping yokes having slidably connection with the body bar, provided at one end with a cam face and at the opposite end with

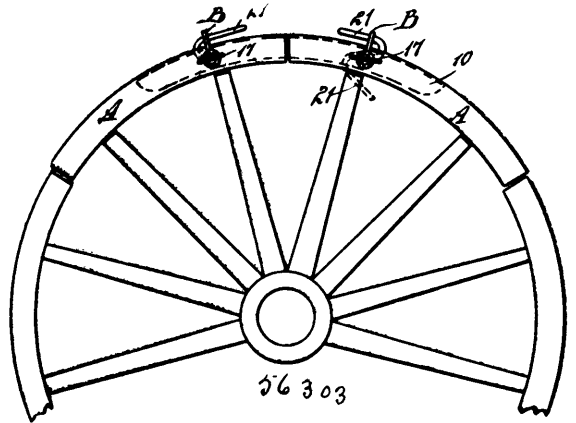

an adjusting screw, and levers provided with cam faces, adapted for engagement with the similar faces of the clamping yokes, the said levers serving to shift the clamping yokes and lock them in their shifted position, substantially as shown and described. 4th. In a rim clamp for wheels, the combination with a body bar, of a fastening device provided at one end with a cam inner face, and at the opposite end with an adjusting screw, and a cam lever mounted between the body bar and the end of the fastening device having a cam face, substantially as described. 5th. In a rim clamp for wheels, the combination with a body bar provided with a spindle mounted to slide therein, of a yoke-shaped fastening device provided at one end with an eye having a cam inner face, and at its other end with an adjusting screw, and a lock lever having a cam surface and mounted on the spindle between the body and the same face of the eye of the yoke, substantially as described.

No. 56,304. Telegraphic Relay. (Relais télégraphiques.)

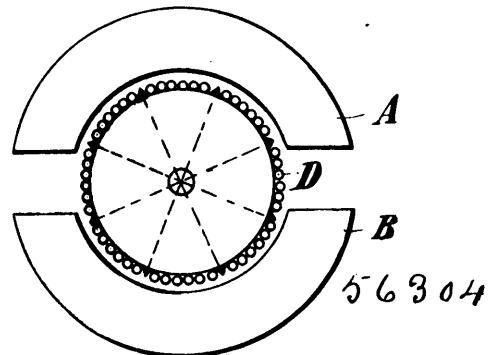

Charles Goodwin Burke, Brooklyn, N.Y., U.S.A., 16th June, 1897 6 years. (Filed 4th May, 1897.)

Claim.—1st. The combination in an instrument of the kind described, of two permanent magnets presenting their respective poles to each other, one pole of one magnet being joined to a like pole of the other magnet by a pole piece of soft iron common to both and forming one side of the field, the other like poles of the magnets being similarly joined together by a soft iron pole piece forming the other side of the field, the conjoined poles of like polarity being in line with each other at one side of the field and parallel with the conjoined poles of opposite polarity at the other side of the field, and a coil supported in the space between the pole-pieces and capable of limited movement at right angles to the lines of force therein. 2nd. A rotary coil for relay instruments adapted to be suspended or supported in a magnetic field and consisting of a spool or core with a conductor wound thereon in convolutions parallel with its axis, the direction of the winding being opposite in opposite halves of the coil, and no two immediately successive convolutions or paths in the same direction being contiguous to each other, as set forth. 3rd. The combination with magnetic poles and within a circular field of force maintained thereby, of a suspended rotary coil, composed of an equal number of sections or divisions, the direction of winding of the sections on one side of the diameter of the coil being opposite to that of the remaining sections, successive convolutions being laid or wound in order in the different sections or divisions, as set forth. 4th. A cylindrical coil wound longitudinally in sections, the course of the wire in adjacent sections of one-half of the coil being in a direction opposite to that of the course of the wire in adjacent sections of the other half of the coil, the direction of the winding

being downward in one section on one side of the coil and upward in the corresponding section at the opposite side of the coil and progressively from section to section.

No. 56,305. Concentrator. (Concentrateur.)

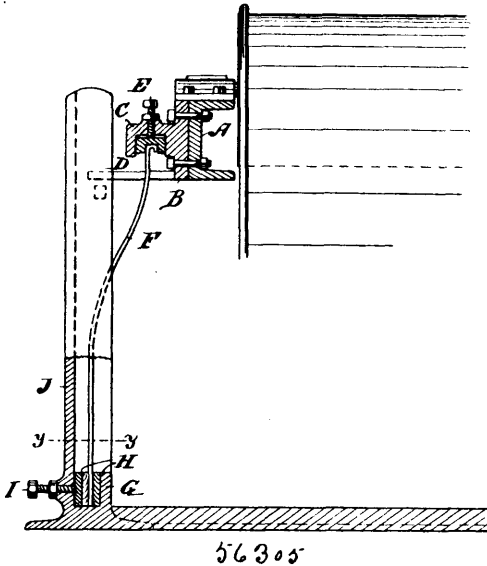

John O. Norborn, San Francisco, California, U.S.A., 16th June, 1897; 6 years. (Filed 7th May, 1897.)

Claim.—1st. The oppositely curved elastic supporting arms or springs upon the upper ends of which the frame of the concentrating table is supported, and means for adjusting said springs. 2nd. The side bars of a concentrating table having supports bolted thereto, vertically adjustable sliding blocks movable in channels therein, said blocks being connected with the upper ends of oppositely curved springs, said springs having the lower ends clamped and supported substantially as described. 3rd. A mechanism for supporting and adjusting the frames of endless travelling concentrator belts consisting of socketed supports having clamps between which the lower ends of oppositely curved springs are secured, attachments to the side bars of the concentrator frame having channels formed therein and socketed blocks slidable vertically in said channels, with adjustable screws, said blocks having the lower faces formed with sockets adapted to receive the upper ends of the spring arms and allow of limited oscillating movement therein.

No. 56,306. Lock. (Serrure.)

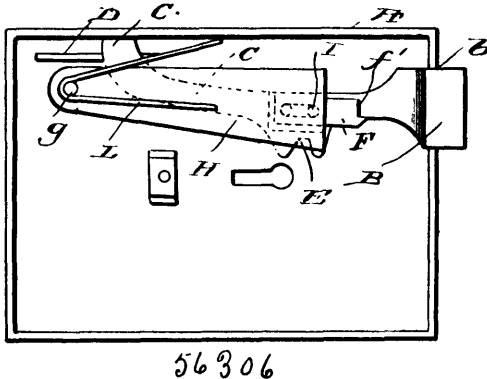

Lewis Sanford Diar, Rankin, Pennsylvania, U.S.A., 16th June, 1897; 6 years. (Filed 8th May, 1897.)

Claim.—1st. The improved lock herein described comprising the case with its cover, the bolt mounted to move through an opening in the end walls of the case and having a curved shank formed upon the under side of its inner end with a groove and with a longitudinal slot, a lug on the inner wall of the case fitting said groove, a pin on the inner wall of the case engaging said slot and a pivoted tumbler with a spring acting thereon, substantially as described. 2nd. The improved lock herein described comprising the case with its cover, the bolt mounted to move through an opening in the end walls of the case and having a curved shank formed upon the under side of its inner end with a groove and with a longitudinal slot, a lug on

the inner wall of the case engaging said slot and a pivoted tumbler with a spring acting thereon, a plate on the upper face of the shank of the bolt and having a notch and a stud on the inner end of the tumbler adapted to engage said notch, substantially as described.

No. 56,307. Corset Stiffener, (Renfort de corset.)

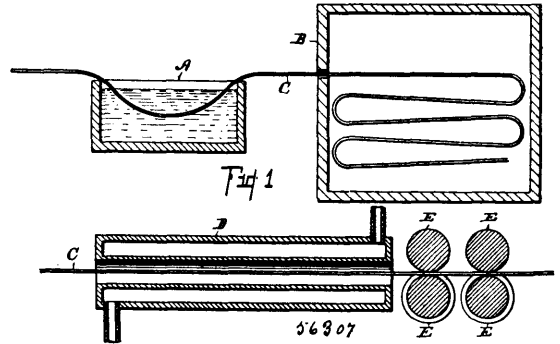

Edward Kirk Warren and Jonas Howard Holden, both of Three Oaks, Michigan, U.S.A., 16th June, 1897; 6 years. (Filed 8th May, 1897.)

Claim.—1st. A process of manufacturing corset stiffeners consisting in bundling together the fibres of quills to form cords or blades, sizing said cords or blades, drying the same, heating the dry sized quills until they are thoroughly softened and applying cold pressure to the same, substantially as set forth. 2nd. A process, in manufacturing corset stiffeners consisting in bundling the fibres of quills into suitable blades, sizing the same, heating the blades until the fibres of the quills become softened, and applying cold pressure to the same to form blades, as specified. 3rd. As an improved article of manufacture, an elastic cord or blade comprising the fibre or splints of feathers, wrapping thread and a sizing, all compacted together and moulded to form the fibre or splints and the thread embedded in the mass, as and for the purpose set forth. 4th. As an improved article of manufacture, an elastic cord or blade comprising the fibre or splints of quills of feathers incorporated together, and a sizing all compacted together and moulded to form the fibre or splints into a continuous mass, as and for the purpose set forth.

No. 56,308. Machine for Pickling Wheat, etc. (Machine pour laver le blé, etc.)

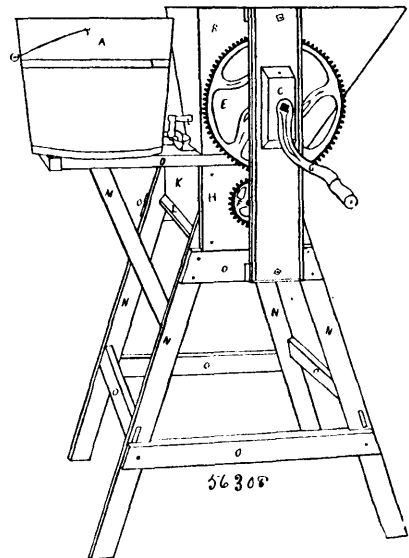

William G. Mattice, Carberry, Manitoba, Canada, 16th June, 1897; 6 years. (Filed 11th May, 1897.)

Claim.—1st. The combination of tube I with box K, substantially as and for the purpose hereinbefore set forth. 2nd. The combination of the screw S with the box K, substantially as and for the purpose hereinbefore set forth.

No. 56,309. Spading Machine. (*Machine à bêcher.*)

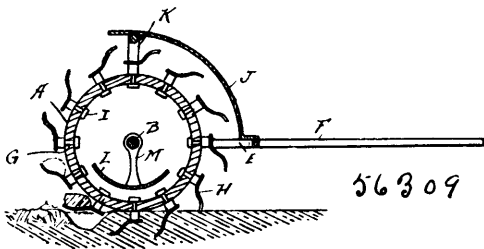

Frederick Holzhauser, Detroit, Michigan, U.S.A., 16th June, 1897; 6 years. (Filed 10th May, 1897.)

Claim.—1st. The combination of the roller having spades secured to the surface thereof, comprising each a sigmoidal blade *a* and a shank *G* formed integral therewith, projecting therefrom at an angle, and provided with a reduced angular portion adapted to a similarly-shaped aperture in the roller, and a screw-threaded end, and a nut for said screw-threaded end, substantially as and for the purpose set forth. 2nd. The combination of the spade roller, a shaft therefor, a draft-frame in which said shaft is mounted, standards on said frame, and a curved plate secured to the draft-frame and to said standards, said draft-frame and plate adapted to be turned on the shaft as an axis to form a sled for carrying the roller, substantially as described. 3rd. The combination of the spade roller, a shaft therefore, a draft-frame secured to the ends of said shaft, standards on said frame on either side of the roller and substantially over the shaft, and a curved plate secured at one end to the draft-frame and at the other end to said standards.

No. 6,310. Tube Coupler. (*Joint de tube.*)

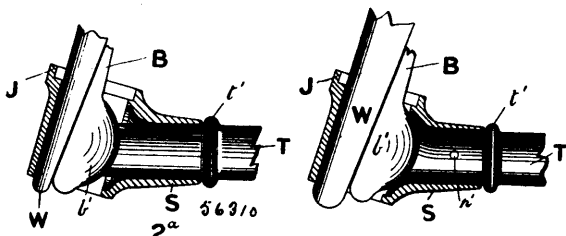

Edwin Taylor, Warstone Lane, Birmingham, Warwick, England, 16th June, 1897; 6 years. (Filed 10th May, 1897.)

Claim.—1st. The improvements in the junctions of tubes with their sockets by expanding the mouth of the tube after it has been inserted into its socket, in the manner substantially as herein set forth and as shown on the accompanying drawings. 2nd. Securing tubes into their sockets by expanding or flattening out the mouth of the tube after it has been inserted into its socket by means of a tool with an enlargement at one end, a wedge-shaped tool or a ball or any suitably shaped wedge piece, and a wedge-shaped tool in the manner substantially as herein set forth, and as shown upon the accompanying drawings. 3rd. Securing tubes into their junctions or sockets by expanding that part of the tube which fits into the junction or socket, and then turning down the edges of the junction or socket into the tube, in the manner as herein set forth and illustrated. 4th. Securing tubes into their junctions by forming the junction larger internally in the centre than at its edges, and expanding the tube in the junction after it has been inserted, in the manner substantially as herein set forth and illustrated on the drawings. 5th. Securing tubes into their junctions by bulging out that part of the tube which is directly over the socket of the junction, in the manner substantially as herein set forth and as illustrated on the accompanying drawings. 6th. Securing tubes into their sockets by bulging the top end of the socket into the mouth of the tube which is expanded in the manner substantially as herein set forth and shown on the drawings. 7th. Securing tubes into their sockets by forming the mouth of the socket elliptical or cone or other shape than round and the end of the tube to correspond, in the manner as herein set forth and as shown on the drawings. 8th. Expanding tubes in their junction and sockets by two plugs caused to advance towards one another by a screw motion, their ends being shaped so as to force apart wedge or other shaped pieces, in the manner substantially as herein set forth and shown. 9th. Expanding tubes in their junctions and sockets by the use of a tapering screw working in two suitably shaped expanding pieces, in the manner substantially as herein set forth and shown on the drawings. 10th. Expanding the mouth of a tube in its socket by two tools whether hinged or not, and a wedge tool which is forced between by another wedge tool, in the manner substantially as herein set forth and as shown on the drawings. 11th. Expanding tubes in their junctions by two tools which are forced apart by a wedge tool, in the manner substantially as herein set forth and as shown. 12th. Expanding tubes in their junctions and sockets by a hinged or flexible tool, in the manner

substantially as set forth and as shown. 13th. Expanding tubes in their sockets and junctions by a flexible tapering tool passing between two wedge tools, in the manner as herein set forth.

No. 56,311. Ventilated Boot and Shoe.

(*Chaussure ventilée.*)

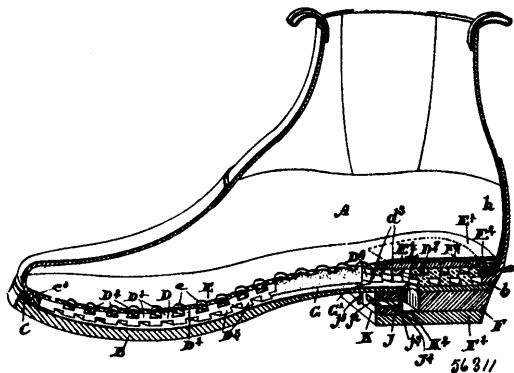

John Ernest Kennedy, Montreal, Quebec, Canada, 17th June, 1897; 6 years. (Filed May 12, 1897.)

Claim.—1st. In a shoe, a collapsible centre sole provided with cross-tongues or ridges, and a longitudinal channel in the same, as and for the purpose specified. 2nd. In a shoe, a collapsible centre sole comprising a central web having upper and lower collapsible tongues extending across the web and forming cross grooves, the tongues on one side being opposite the grooves on the other, as and for the purpose specified. 3rd. In a shoe collapsible centre sole comprising a central web having upper and lower collapsible tongues extending across the web and forming cross grooves, the tongues on one side being opposite the grooves on the other and a channel extending longitudinally through substantially the centre of the sole, as and for the purpose specified. 4th. In a shoe, a collapsible centre sole comprising a central web having upper and lower collapsible dovetail-shaped cross tongues extending across the web and forming correspondingly shaped grooves, the tongues on one side being opposite the grooves on the other, as and for the purpose specified. 5th. In a shoe, a collapsible centre sole comprising a central web having upper and lower collapsible tongues extending obliquely across the web and forming correspondingly shaped grooves, the tongues on one side being opposite the grooves on the other, as and for the purpose specified. 6th. In combination, the upper, the welt, the outer sole, and the collapsible centre sole provided with cross tongues or ridges having lateral extensions extending underneath the welt, and means for securing such extensions in position, as and for the purpose specified. 7th. In combination the upper, the welt, the outer sole and the collapsible centre sole provided with cross tongues or ridges having lateral extensions extending underneath the welt, means for securing such extensions in position, and an insole having a downwardly projecting rib extending around the vertical upper portion of the toe and sides of the collapsible centre sole, as and for the purpose specified. 8th. In combination the upper, the welt, the outer sole, the collapsible centre sole provided with cross tongues or ridges, and a central channel, the insole provided with a line of perforations above the central channel, and an aperture in the heel of the boot connecting the said channel with the outer air, as and for the purpose specified. 9th. In combination the upper, the welt, the outer sole, the collapsible centre sole provided with cross tongues or ridges, and a central channel having an enlarged central portion extending over the arch of the sole, and a narrowed rear portion extending beneath the top tongues of the heel portion of the collapsible sole, so as to form openings between the tongues, and a compressible flap forming part of the heel portion of the insole and designed to be brought to press against the heel portion of the collapsible centre sole, as and for the purpose specified. 10th. In combination the upper and outer sole, the collapsible centre sole provided with cross tongues or ridges at the heel portion thereof, a central channel extending into the lower portion of such heel portion, and communicating with the upper part by openings between the tongues, an insole covering the collapsible centre sole and provided with a heel flap designed to be brought to press against the heel portion of the collapsible centre sole, and an aperture in the heel of the boot connecting the centre channel with the outer air, as and for the purpose specified. 11th. In combination, the upper and outer sole, the collapsible centre sole provided with cross tongues or ridges at the heel portion thereof, a central channel extending into the lower part of such heel portion and communicating with the upper part by openings between the tongues, an insole covering the collapsible centre sole and having the heel portion horizontally slit to form two flaps, an opening formed in the lower flap, a layer fitting such opening and resting upon the tongues of the collapsible centre sole, and an aperture in the heel of the boot connecting the centre channel with the outer air, as and for the purpose specified. 12th. In combination, the upper and the outer sole, the collapsible centre sole

provided with cross tongues or ridges, and a channel extending into the toe and heel portion, the insole provided with suitable openings communicating with the channel, the heel, the chamber therein, an opening in the outer sole communicating with such chamber, and a valve connecting such chamber to the outer air, and so constructed as to allow the air to pass inwardly, but not outwardly, as and for the purpose specified. 13th. In combination, the upper and the outer sole, the collapsible centre sole and openings in the same communicating with the interior of the boot, and a valve connecting such openings with the outer air, and so constructed as to allow the air to pass inwardly but not outwardly, as and for the purpose specified. 14th. In combination, the upper and the outer sole, the collapsible centre sole and channel opening in the same, the heel, the chamber in the heel, the opening connecting such chamber to the channel opening in the collapsible centre sole, the valve in the front end of the heel, and a suitable flap located in the chamber in the heel and covering the inner opening of the valve, as and for the purpose specified. 15th. In combination, the upper and the outer sole, the collapsible centre sole and channel opening in the same, the heel, the chamber in the heel having a dove-tail front end, the valve casing correspondingly dove-tail shaped to fit such chamber provided with the front plate and registering inner and outer slots, the roller valve provided with a central aperture, and a pin extending through a slot in the front plate for controlling said valve and for the purpose specified.

No. 56,312. Heater. (Chaufeur.)

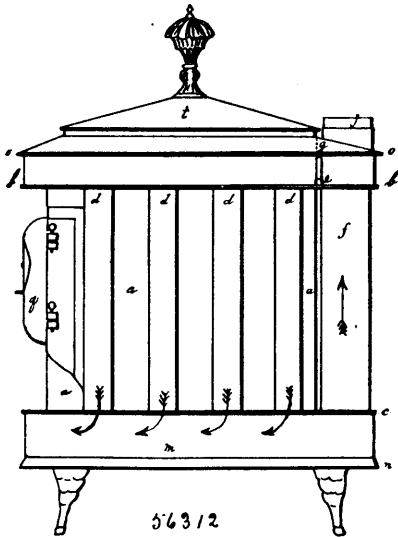

Robert O. Dobbin, Waterloo, Ontario, Canada, 17th June, 1897; 6 years. (Filed 13th May, 1897.)

Claim.—1st. In a heater, the arrangement of a series of pipes or tubes *d* on either side of a fire box and connected therewith by means of two projecting rims *bb, cc*, as and for the purpose herein specified. 2nd. In a heater, the combination with the fire box *a* and a series of tubes *d*, of the flues *h, i* and *f*, constructed as and for the purpose herein specified. 3rd. In a heater, the combination with a fire-box *a*, flues *d, h, i* and *f* and outlet *j*, of the direct draught damper placed at the rear of fire-box and so constructed that when it is open the products of combustion will pass directly to the outlet of the heater and when closed they will pass successively through the flues *d, h, i* and *f* to the same outlet *j*.

No. 56,313. Electric Pump. (Pompe électrique.)

George F. Atwood, Boston, Mass., U.S.A., 17th June, 1897; 6 years. (Filed 13th May, 1897.)

Claim.—1st. In a water elevating apparatus, the combination of a tank, a pump, a connection between the discharge pipe of the pump and the tank, a shaft journalled in suitable bearings and having a crank connected by a pitman with the piston of the pump, a gear wheel fixed on the shaft, an electro-motor having a worm on its shaft or arbor in mesh with the said gear wheel, an electric generator, an electric connection between one pole of said generator and the commutator of the motor, the contact pieces arranged above the tank, an electrical connection between the other pole of the generator and one contact piece, an electrical connection between the other contact piece and the commutator of the motor, a float in the tank, and a piece of conductive material interposed between the contact pieces and connected with the float and adapted when the float moves downwardly to effect electric connection between the

contact pieces and close the circuit and, when the float is raised to interrupt the circuit, substantially as specified. 2nd. In a water

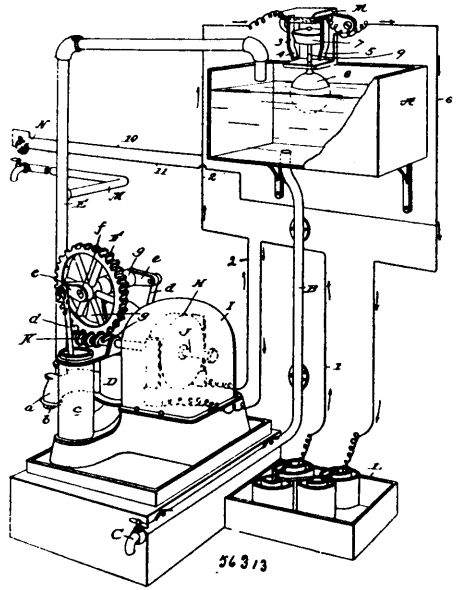

pumping apparatus, the combination of a pump having a discharge pipe, a shaft journalled in suitable bearings and having a crank connected by a pitman with the piston of the pump, a gear wheel fixed on the shaft, an electro-motor having a worm on its shaft or arbor in mesh with the said gear wheel, an electric generator, and a circuit closing device electrically connected with the electro-motor and the electric generator, substantially as specified. 3rd. In a water elevating apparatus, the combination of a tank, resilient contact pieces arranged above the tank and having the inwardly inclined lower portions, a float in the tank, and a piece of conductive material connected with the float and arranged between the contact pieces, substantially as specified.

No. 56,314. Railway Switch.

(Aiguille de chemins de fer.)

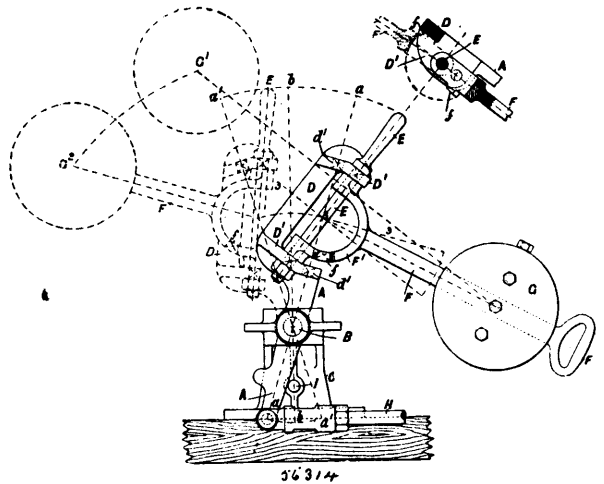

Gustave Jean Marie Vanneste, Brussels, Belgium, 17th June, 1897 6 years. (Filed 14th May, 1897.)

Claim.—1st. The combination with a switch lever pivoted upon a horizontal axis, of a weighted arm pivoted about an axis formed or carried by the lever, the axis of the weighted arm being normally at such an inclination that throughout the oscillation of the lever the axis will make an acute angle in the same direction with regard to the horizontal so that the weighted arm after having oscillated the lever from its normal position will always tend to swing back again and to return the lever and switch to the normal position, substantially as specified. 2nd. In a switch lever combined with a weighted arm pivoted to swing about an axis carried by the lever for the purpose of oscillating said lever, the switch lever constructed with a bracket portion so formed as to admit of the said axis being mounted either at an angle to the lever or in line therewith, the weighted arm being so formed as to enable the arm to be adapted to

either position of the axis by merely reversing the arm as specified. 3rd. A switch operating lever mounted to oscillate on a horizontal axis and adjusted to move through an arc wholly on one side of the vertical passing through said axis in combination with a weighted arm pivoted to swing about the said lever itself as an axis and with a stop on the lever to limit the motion of the arm about the lever so that when arrested by said stop the weighted arm will be in an unstable position from which it will tend to return by gravity to its normal position and thereby to also return the switch to its normal position, as specified. 4th. A switch operating lever mounted to oscillate on a horizontal axis in combination with a weighted arm pivoted to swing about the said lever itself as an axis and with a screw coupling connecting the switch lever and switch rod and permitting the adjustment of the position of the arc through which the lever oscillates with regard to the vertical through the axis of oscillation of the lever in order that the return action of the lever may be readily made automatic or not as required. 5th. A switch operating lever mounted to oscillate on a horizontal axis in combination with a weighted arm pivoted to swing about the said lever itself as an axis and with a screw coupling connecting the switch lever and switch rod and permitting the adjustment of the position of the arc through which the lever oscillates with regard to the vertical through the axis of oscillation of the lever, the said arm being at such an angle to its axis that by inverting it upon its axis its height will be adapted to suit the position of the arc of oscillation of the switch lever according as the return action of said lever is to be automatic or non-automatic as specified.

No. 56,315. Moistening Brushes. (Brosse à humecter.)

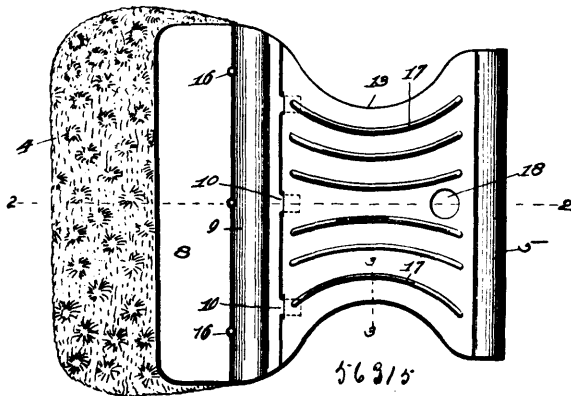

George E. Mayger, St. Louis, Missouri, U.S.A., 17th June, 1897; 6 years. (Filed 14th May, 1897.)

Claim.—In a device of the class described, a brush formed of sponge, and a non-corrosive sheet metal handle attached to said sponge, substantially as specified. 2nd. In a device of the class described, a brush formed of sponge, a sheet metal plate placed with one of its edges in contact with said sponge, a second sheet metal plate upon the opposite side of said sponge from the first mentioned plate and having arms projecting from one of its edges through apertures in the first mentioned plate, thus forming connections between the two plates, and rivets inserted through said plates and through said sponge as required to hold said sponge securely in position between said plates, substantially as specified. 3rd. In a device of the class described, the brush 4 formed of sponge and the handle 5 formed of non-corrosive sheet metal, said handle consisting of the pieces 6 and 7, said piece 7 consisting of the portions 8 and 9 formed integral, and the arms 10 projecting from one edge of said portion 9, said piece 6 consisting of the portions 11, 12, 13 and 14 formed integral and having the apertures 15 to receive the arms 10, and said portion 13 having beads 17, and the rivets 16 connecting said pieces 6 and 7, substantially as specified.

No. 56,316. Hook and Eye. (Porte et agrafe.)

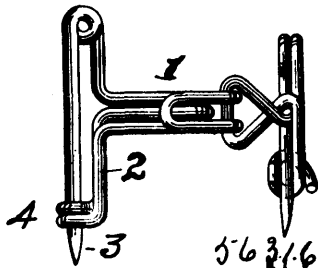

Virginia Brown, Houstonia, Missouri, U.S.A., 17th June, 1897; 6 years. (Filed 14th May, 1897.)

Claim.—1st. A hook forming part of the ordinary hook and eye having a safety-pin attachment at its rear end, and a pin projecting

rearward from the forward end of the hook, substantially as shown and for the purpose set forth. 2nd. A hook forming part of the ordinary hook and eye having a safety-pin attachment at the rear end of the hook, the wire of which the hook is made being extended between the portions forming the shank and turned back upon itself to provide the additional pin, substantially as and for the purpose set forth. 3rd. An eye forming part of the ordinary hook and eye made up of wire bent upon itself centrally to form a loop in the rear of which the parts are twisted upon themselves and extended to form an ordinary safety-pin, substantially as shown and described.

No. 56,317. Piano Stool. (Banc de pianos.)

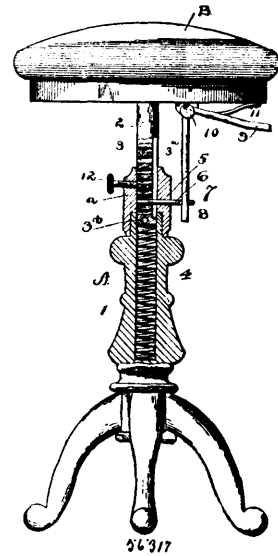

Samuel Smith Goshorn, Philadelphia, Pennsylvania, U.S.A., 17th June, 1897; 6 years. (Filed 14th May, 1897.)

Claim.—In a stool of the class described, the combination with a stool standard provided with a vertically extending opening, of a seat, a stem connected to the seat and slidable in the opening, being provided with a series of transversely extending apertures and a longitudinally extending groove, a coil spring seated in the opening and pressing against the bottom end of the stem, a pin movable in the standard and adapted to enter the grooves and apertures, a spring pressed bell crank lever hinged to the seat and adapted for operating the pin, and a clamping screw adapted to bind on the stem.

No. 56,318. Seed Attachment for Wagons.

{(Attache de trainaux pour wagons.)

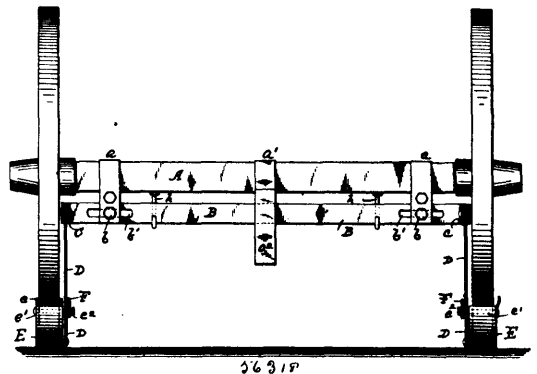

Peter Henseler, Union Hill, New Jersey, U.S.A., 17th June, 1897; 6 years. (Filed 17th March, 1897.)

Claim.—1st. The combination, with the axle of a vehicle, of a transverse supporting bar arranged parallel with the axle, hinged pieces applied to the ends of said supporting bar, U-shaped runners, pivot-links connecting the said hinged pieces with the runners, and means for locking the runners to the wheels, substantially as set forth. 2nd. The combination, with the axle of a vehicle, of a transverse supporting bar arranged parallel with the axle, hinged pieces

applied to the ends of said bar, U-shaped runners, pivot-links between the hinged pieces and the runners, means for supporting the runners and intermediate pieces in a position parallel with the axle, and means for locking the runners to the wheels at right angles to the axles, substantially as set forth. 3rd. The combination, with the axle of a vehicle having clips, of a transverse supporting bar attached to said clips, a central hanger applied to the axle, folding pieces hinged to the ends of the supporting bar, runners adapted to be applied to the wheels and provided with hooded transverse pins, pivot-links connecting the folding pieces with the runners, and locking hooks connecting the pivot-links with the transverse pins of the runners, substantially as set forth.

No. 56,319. Fabric Branding Compound.
(Composé pour marquer les tissus.)

Alice Louisa Potter, Neptune Street, Saint Kilda, Victoria, Australia, 17th June, 1897; 6 years. (Filed 4th May, 1897.)

Claim.—A compound consisting of glue, gelatine, or size, water, bicromate of potash, lamp-black, raddle or other suitable colouring matter, turpentine or other drying liquid, to which may be added Spanish clay, mixed together and heated by boiling, substantially in the proportions, and for the purposes hereinbefore described.

No. 56,320. Boxes, Cases and Crates.
(Boîte, caisse à claire-voie.)

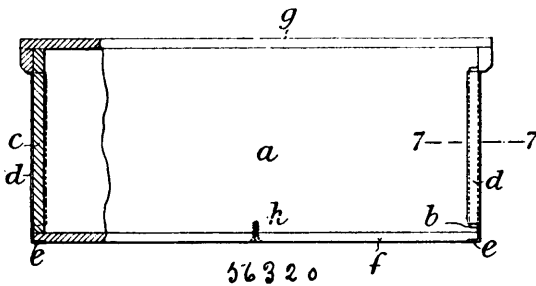

Hyman Abraham, London, England, 17th June, 1897; 6 years. (Filed 15th May, 1897.)

Claim.—1st. A box, case or crate wherein the sides (or ends) are provided at their edges with strips adapted to slide into metal channels or clips on the edges of the ends (or sides), the said ends or sides being also provided at their bottoms with metal channels or clips to receive the bottom of the box, substantially as and for the purpose hereinbefore described. 2nd. The case or box and the crate hereinbefore described and illustrated, and each consisting of the sides *a, a*, having the strips *b, b*, of the ends *c, c*, having the metal channels *c, c*, and the metal clips *d, d*, into which the strips *b, b* slide, of the bottom *f*, which slides into the said channels, and of the cover or lid *g*.

No. 56,321. Fire Bridge for Boiler Furnaces.
(Pont à feu pour fournaies de chaudières.)

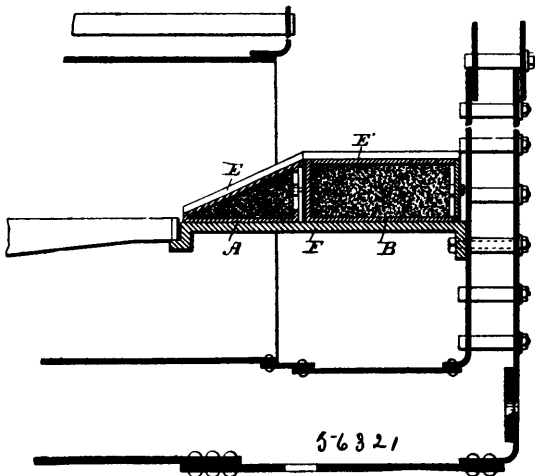

James Reagan, Philadelphia, Pennsylvania, U.S.A., 17th June, 1897; 6 years. (Filed 15th May, 1897.)

Claim.—1st. A fire bridge composed of the sections *A* and *B*, of box line form, having inclined and flat tops respectively, and grooves or channels *E* and *E'*, formed therein, with the interior and grooves filled with ashes or other non-conductors of heat, substantially as and for the purpose specified. 2nd. A fire bridge com-

posed of the hollow sections *A* and *B*, having open ends *C, C'*, and covers or lids *D, D'*, for the introduction of ashes or other material, and grooves or channels *E, E'*, on the upper surface for the intention of ashes, substantially as specified. 3rd. The combination in a fire bridge, of the hollow sections *A* and *B*, covers or lids *D, D'*, tap bolts *k*, grooves or channels *E, E'*, tongues and grooves *G, G'*, substantially as specified.

No. 56,322. Barn Frame. (Charpente de granges.)

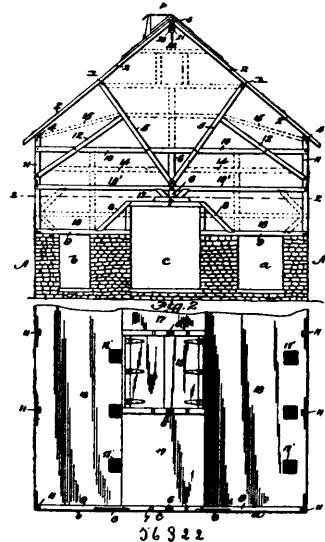

Robert Samuel McPheeters, Helena, Minnesota, U.S.A., 17th June, 1897; 6 years. (Filed 15th May, 1897.)

Claim.—1st. The improved barn frame comprising the usual side posts, horizontal plates and inclined rafters, the purlins *1*, arranged in the middle of the latter, the purlin braces *5*, extending downward and inward, the vertical centre posts *6*, on which the braces converge, the supplemental inclined braces *12*, connecting said side posts and purlin braces, and the horizontal brace-and-tie beams *10*, connecting and gained into opposite side posts, centre post, purlin braces and supplemental braces, as shown and described. 2nd. The combination with the basement, having a central drive-way *c*, provided with a hatch as specified, of the frame having inclined rafters and a connecting ridge-pole, the purlins, and inwardly inclined or converging braces *5*, for the latter, centre posts on which the braces are set, a track arranged directly beneath the ridge pole, a carriage running thereon, and a hay sling suspended from said carriage, for elevating hay through the hatch and conveying it between opposite purlin braces toward either end of the barn, as shown and described.

No. 56,323. Railroad Spike. (Cheville de chemin de fer.)

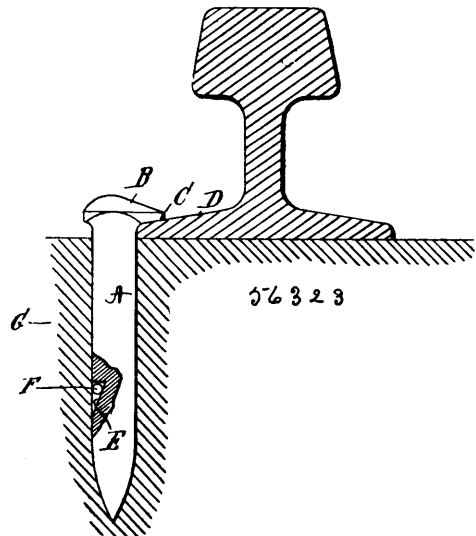

Righter William Beidleman, Nanticoke, Pennsylvania, U.S.A., 17th June, 1897; 6 years. (Filed 17th May, 1897.)

Claim.—1st. A spike provided with a notch or recess in one side thereof, the back of which forms an outwardly and downwardly

directed inclined plane, as a roller mounted or placed in said notch or recess, substantially as shown and described. 2nd. A railway spike, which is provided with a head, and a flat slide or surface, said flat side or surface being provided with a notch or recess which is triangular in form in vertical section, whereby an outwardly and downwardly inclined plane is formed, and a roller mounted or placed in said notch or recess, substantially as shown and described.

No. 56,324. Range or Stove for Cooking.
(Poêle de cuisine.)

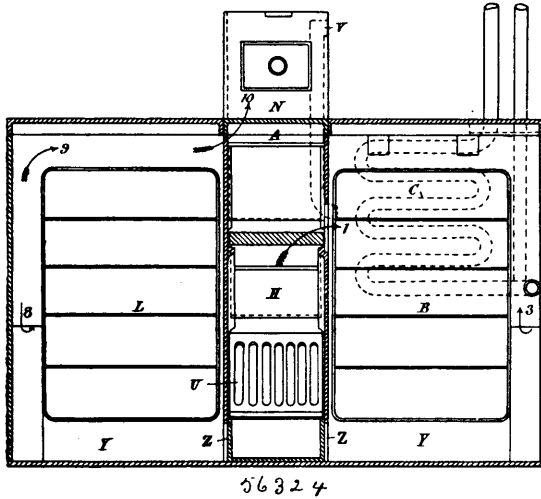

Lawson Tait, Birmingham, Warwick, England, 17th June, 1897; 6 years. (Filed 17th May, 1897.)

Claim.—1st. A range or stove for cooking, having a fire box inclined downwards from the front to rear closed at the upper part and with fire bars or grate at the lower part, and there also an entrance to a chamber in which an oven is contained. 2nd. The combination consisting of the inclined fire box A, and the lid F and the fire bars G, the oven chamber communicating with the fire box, the hot oven B therein, and a coil of pipe C in the chamber serving as a water heater or boiler. 3rd. The combination consisting of the inclined fire box A, the lid F and the fire bars G, the oven chamber communicating with the fire box, the hot oven B therein, and a sliding damper H immediately beneath the fire bars or grate. 4th. The combination consisting of the inclined fire box A, the lid F and the fire bars G, the oven chamber communicating with the fire box, the hot oven B therein, and an air supply pipe delivering heated air at the entrance to the chamber to meet the highly heated gases leaving the fire. 5th. The combination consisting of the inclined fire box A, the lid F and the fire bars G, the oven chamber communicating with the fire box, the hot oven B therein, and a flue passage M from the chamber containing the hot oven B, over the fire box A into a second chamber containing a cool oven L. 6th. The combination consisting of the inclined fire box A, the lid F and the fire bars G, the oven chamber communicating with the fire box, the hot oven B therein, and an inclined grid U and divided ash pan S T by which cinders and ashes are separated and separately collected.

No. 56,325. Brace for Structures. (Tirant pour édifices.)
Edgar Kidwell, Houghton, Michigan, U.S.A., 17th June, 1897; 6 years. (Filed 17th May, 1897.)

Claim.—1st. The combination of a structure to be braced, shoes secured thereto, a brace adjustable in said shoes and means for adjusting the brace, substantially as described. 2nd. The combination of a structure to be braced, shoes secured thereto, sockets carried by the shoes, said sockets being oppositely screw-threaded, and a brace having its ends oppositely screw-threaded, said brace adapted to extend within the sockets and be adjusted therein, substantially as described. 3rd. The combination of a structure to be braced, shoes secured thereto and provided with lugs, the supporting timber of the lugs being recessed to receive the lugs, sockets carried by the shoes and oppositely screw-threaded, and a brace having its ends screw-threaded to correspond with the sockets in which its ends extend and in which it is adjustable, substantially as described. 4th. The combination of a structure to be braced, shoes provided with a series of inclined projections, the timbers of the structure recessed to correspond to the shape of the projections of the shoes, and a brace adjustable in the shoes, substantially as described. 5th. The combination of a structure to be braced, shoes secured to the same, said shoes provided with wedge-shape openings, a brace having its ends extending within the shoes and slotted, and wedges adapted to be driven through the openings in the shoes and engage the slotted ends of the brace for adjusting the same, substantially as described. 6th. The combination of a structure to be braced,

shoes secured to the same, sockets carried by the shoes, braces secured within the sockets and having their meeting ends oppositely

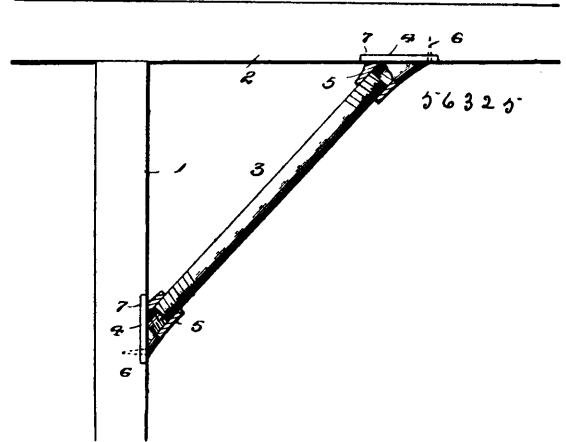

screw-threaded, and a sleeve provided with opposite screw-threads, adapted to connect the ends of the braces and be moved thereon for adjusting the same, substantially as described. 7th. The combination of a structure to be braced, shoes secured to the same, sockets carried by the shoes, a brace adapted to fit at one end within one of said sockets and adjustable at its opposite end within the other socket, said brace having perforations therein, said perforations being at angle to each other, and a rod adapted to be inserted through said perforations for adjusting the brace, substantially as described.

No. 56,326. Hot Water Heater. (Calorifère à eau.)

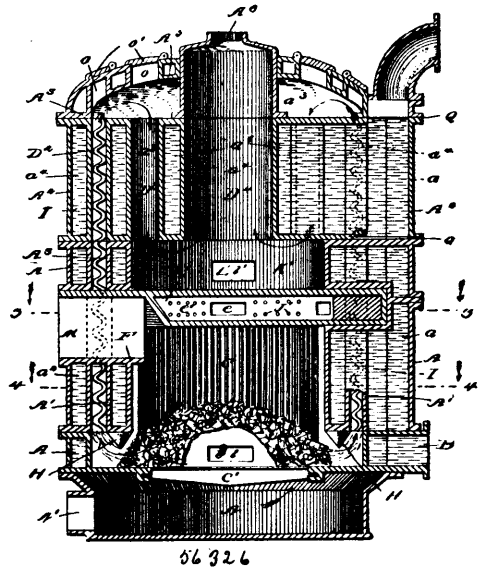

Robert H. Laird, Pittsburg, Pennsylvania, U.S.A., 17th June, 1897; 6 years. (Filed 17th May, 1897.)

Claim.—1st. The combination of a fuel pot, a hot air chamber over the fuel pot, passage-ways from the chamber to the outside thereof, and passage-ways from such chamber to the fuel pot, means for supplying air to the fuel pot through the grate bars thereof, water receptacles around the fuel pot A, below the hot air chamber, means for discharging below the adjacent water receptacle surrounding it, the products obtained in such fuel pot, passage-ways through the water receptacles for the products so discharged from the fuel pot, and passage-ways communicating with the last named passage-ways and with the chimney through the hot air chamber, substantially as described. 2nd. The combination of a fuel pot, a hot air chamber over the fuel pot, passage-ways from the chamber to the outside thereof, and passage-ways from such chamber to the fuel pot, means for supplying air to the fuel pot through the grate bars thereof, water receptacles around the fire pot below the hot water chamber, passage-ways through the water receptacles for the products obtained in the fuel pot, and passage-ways communicating with the last named passage-ways and with the chimney through the hot air chamber to the passage-ways extending therethrough.

substantially as described. 3rd. The combination of a fuel pot, a hot air chamber over the fuel pot, passage-ways from the hot air chamber to the outside thereof, and passage-ways from such hot air chamber to the fuel pot, means for supplying air to the fuel pot through the grate bars thereof, water receptacles around the fire pot below the hot air chamber, and receptacles for water above such hot air chamber, passage-ways through the water receptacles for the products obtained in the fuel pot, the passage-ways through the water receptacles above the hot air chamber, communicating with the chimney and passage-ways, through the hot air chamber connecting the passage-ways through the water receptacles, below the hot air chamber with the passage-ways through the water receptacles above such hot air chambers, substantially as described. 4th. The combination of a fuel pot, a hot air chamber over the fuel pot, passage-ways from the hot air chamber to the outside thereof, and passage-ways from such hot air chamber to the fuel pot, means for supplying air to the fuel pot through the grate bars thereof, water receptacles around the fire pot below the hot air chamber, and receptacles for water above such hot air chamber, passage-ways through the water receptacles for the products obtained in the fuel pot, the passage-ways through the water receptacles above the hot air chamber communicating with the chimney, and passage-ways through the hot air chamber connecting the passage-ways through the water receptacles below the hot air chamber with the passage-ways through the water receptacles above such hot air chamber, with passage-ways from the hot air chamber to such passage-ways extending there-through, substantially as described. 5th. The combination of a fuel pot, a hot air chamber over the fuel pot, means for supplying air to the hot air chamber, passage-ways from the hot air chamber to the fuel pot above the fuel therein, means for supplying air to the fuel in the fuel pot through the grate thereof, and means for discharging the products obtained in the fuel pot midway of the burning fuel, whereby the air coming through the grate bars and through the passage-ways from the hot air chamber extends through the burning fuel. 6th. The combination of a fuel pot, with vertical grooves larger at the back thereof than at the open face in the wall of the fuel pot, a hot air chamber over the fuel pot, means for supplying air to the hot air chamber, passage-ways from the hot air chamber to the fuel pot above the fuel therein, means for supplying air to the fuel in the fuel pot through the grate thereof, and means for discharging the products obtained in the fuel pot midway of the burning fuel, whereby the air coming through the grate bars and through the passage-ways from the hot air chambers extends through the burning fuel. 7th. In a hot water heater, a fuel pot, a hot air chamber over the fuel pot, means for supplying air to the hot air chamber, passage-ways from the hot air chamber to the fuel pot above the fuel therein, means for supplying air to the fuel in the fuel pot through the grate thereof, and means for discharging the products obtained in the fuel pot midway of the burning fuel, and means for supplying additional air from the hot air chamber to the fuel pot, whereby the air coming through the grate bars and through the passage-ways from the hot air chamber extends through the burning fuel, and additional hot air is supplied to the products obtained after such products have left the fuel pot, substantially as described. 8th. In a hot water heater, a fuel pot, with vertical grooves larger at the back thereof than at the open face in the wall of the fuel pot, a hot air chamber over the wall of the fuel pot, means for supplying air to the hot air chamber, passage-ways from the hot air chamber to the fuel pot above the fuel therein, means for supplying air to the fuel in the fuel pot through the grate thereof, and means for discharging the products obtained in the fuel pot midway of the burning fuel, and means for supplying additional air from the hot air chamber to the fuel pot, whereby the air coming through the grate bars and through the passage-ways from the hot air chamber extends through the burning fuel, and additional hot air is supplied to the products obtained in the fuel pot after such products have left such fuel pot, substantially as described. 9th. A hot air chamber consisting of a fire clay disc, a second fire clay disc and a fire clay ring, with fire clay pipes extending through the discs and chamber with perforations through the bottom disc, substantially as described. 10th. A hot air chamber consisting of a fire clay disc, a second fire clay disc and a fire clay ring, with fire clay pipes extending through the discs and chamber with perforations through the bottom disc and through the pipes from the chamber, substantially as described. 11th. A hot air chamber, consisting of discs and rings, composed of refractory material, pipes extending through the discs and chamber with perforations through the bottom disc, substantially as described. 12th. A hot air chamber consisting of discs and rings composed of refractory material, pipes extending through the discs and chamber, with perforations through the bottom disc and through the pipes from the chamber, substantially as described. 13th. The combination of a fuel pot, a hot air chamber over the fuel pot, passage-ways from the hot air chamber to the outside thereof, and means for supplying steam through the hot air chamber to the fire pot, substantially as described. 14th. The combination of a fuel pot composed of refractory material, a hot air chamber over the fuel pot, passage-ways for the discharge of the products obtained in the fuel pot at its lower end and connected with an annular exit flue between the fuel pot and the outer casing, substantially as described. 15th. The combination of a fuel pot, vertical grooves larger at the back thereof than

at the open face in the wall of the fuel pot, a hot air chamber over the fuel pot, means for supplying air to the hot air chamber, passage-ways from the hot air chamber to the fuel pot above the fuel therein, means for supplying air to the fuel pot through the grate thereof, and means for discharging the products obtained in the fuel pot at the lower end thereof, through an annular exit flue or passage-way between the fuel pot and the outside casing thereof, means for supplying additional air from the hot air chamber to the annular exit flue from the fuel pot, whereby the air coming through the grate bars and through the passage-way from the hot air chamber extends through the burning fuel and additional hot air is supplied to the products obtained in the fuel pot after such products have left such fuel pot, substantially as described. 16th. The combination of the fuel pot, vertical grooves larger at the back thereof than at the open face in the wall of the fuel pot, a hot air chamber over the fuel pot, means for supplying air to the hot air chamber, passage-ways from the hot air chamber to the fuel pot above the fuel therein, means for supplying air to the fuel in the fuel pot through the grate thereof, and means for discharging the products obtained in the fuel pot at the lower end thereof, substantially as described. 17th. The combination of a fuel pot, a hot air chamber consisting of discs and rings with pipes extending through the discs and chamber, and a water extension through the medium of said discs, substantially as shown and described.

No. 56,327. Show Window. (*Fenêtre d'étalage.*)

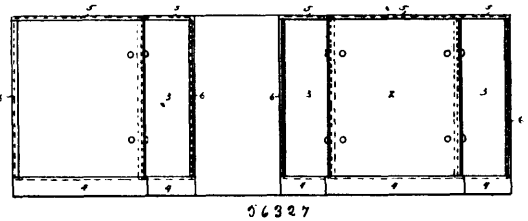

Frederick Pollard, Cleveland, Ohio, U.S.A., 17th June, 1897; 6 years. (Filed 17th May, 1897.)

Claim.—1st. The combination in a show window, of a base, a top and end frames, two or more abutting glass plates, and metallic straps secured to said plates near their adjacent ends by bolts and nuts, substantially as and for the purpose set forth. 2nd. The combination in a show window, of a base, a top and end frames, two or more abutting glass plates, metallic straps secured to said plates near their adjacent ends by bolts and nuts, and a soft strip and water-tight filling between adjacent surfaces of said plates, substantially as and for the purposes set forth.

No. 56,328. Bread Raiser. (*Four pour le pain.*)

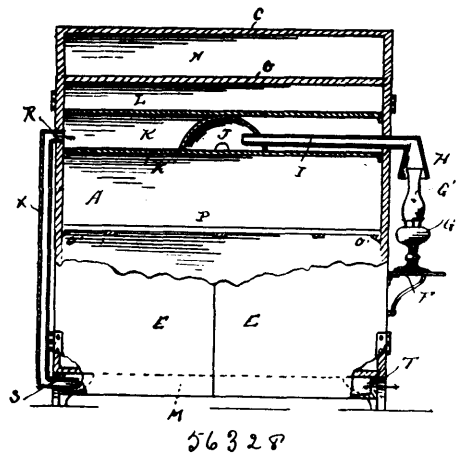

Jennie M. Tinker, Ellwood, Pennsylvania, U.S.A., 17th June, 1897; 6 years. (Filed 17th May, 1897.)

Claim.—The combination with the oven having a partition and a plate above the same, forming between them a hot-air chamber, of a reflector arranged within the hot-air chamber between said partition and plate, a bracket secured to the outer wall of the oven for supporting a lamp, and a pipe extending into the hot-air chamber and through said reflector, and having at its outer end a cone-shaped pipe, the bottom open end of which is arranged above said bracket and adapted to receive the upper end of the lamp chimney, all substantially as herein shown and described.

No. 56,329. Gang-Saw Mill. (Scierie.)

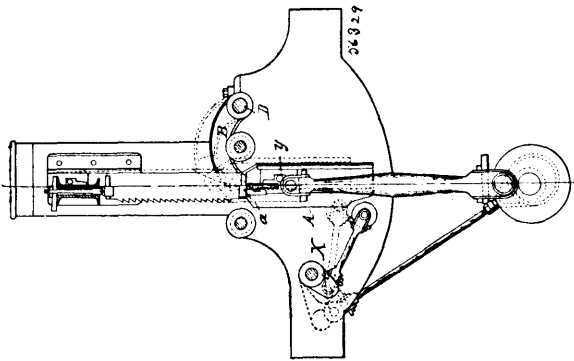

Daniel Crane, Saginaw, Michigan, U.S.A., 18th June, 1897; 6 years. (Filed 17th May, 1897.)

Claim.—1st. The combination in a gang-saw mill, of the lower oscillating slides A, A, the rock-arms B, B, to which said slides are pendulously secured by swing-pins, the shaft D carrying the rock-arms, the quadrant-arm E on said shaft, the worm G with which said quadrant engages, actuating connection for said worm for imparting motion thereto at will in reverse directions, the lifting-arm F secured to shaft D, and means operated by said arm for controlling the rate of feed, all substantially as set forth. 2nd. In a gang-saw mill, the combination with the feed mechanism and fixed upper slide-ways, of lower oscillatory slideways, rock-arms on a rock-shaft to which said oscillatory slide-ways are pivotally secured, means for imparting motion to said rock-shaft in reverse directions to raise or lower said oscillatory slideways, and a connection between said rock-shaft and feed mechanism adapted to correspondingly accelerate or retard the feed, substantially as described. 3rd. In a gang-saw mill, the combination with the feed-rolls, the oscillatory slideways and rock-arms on a rock-shaft to which said slideways are pivotally secured, of the combination wheel I adapted to be drawn peripherally, one side thereof forming a face-plate friction and the other being provided with opposite annular friction-faces, a friction-wheel between said annular faces adapted to be moved into contact with either and to be driven thereby in reverse directions, connection between said friction-wheel and the rock-shaft, and an edge friction-wheel in engagement with the face-plate friction, forming a variable-speed drive in connection for the feed-rolls, substantially as described. The combination in a gang-saw, of the rocker-base J and the combination-lever L, having shaft M provided with the lever N, the eccentric O with its rod connected to lever R, all substantially as set forth. 5th. The combination with the wheel I having opposite annular friction-faces and the oscillatory slideways pendulously secured to rock-arms on the rock-shaft, of the shaft G¹, the hollow shaft H sleeved thereon having the extension-arm h, the friction-wheel f, journaled at the end of the arm b between the opposite annular faces of the wheel I, a sprocket and chain connection between said friction-wheel and the shaft G¹, a drive connection between said shaft and the rock-shaft, and means for moving said friction-wheel f at will into contact with one or the other of said annular faces, substantially as described.

No. 56,330. Mechanical Sugar Bowl. (Sucrier.)

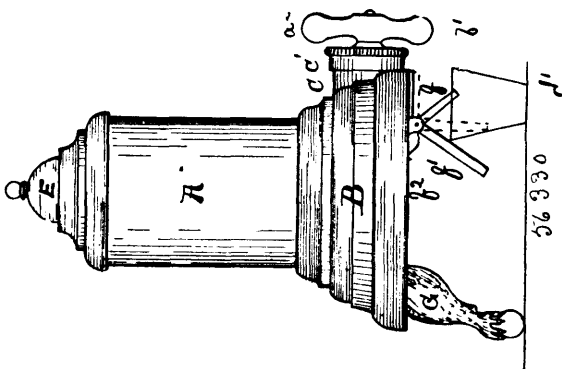

William Leslie Cameron, Chatham, Ontario, Canada, 18th June, 1897; 6 years. (Filed 17th May, 1897.)

Claim.—1st. The combination of the tank A, having the hopper bottom B connected to the tubular chamber C, substantially as specified. 2nd. The combination of the tank A, having the hopper bottom B, connected to the tubular chamber C, containing the rotating worm conveyer D, substantially as set forth. 3rd. The combination of the tank, having a hopper bottom and the tubular

chamber, containing the rotating worm conveyer, engaging with the handle for the operation of the said conveyer, substantially as specified. 4th. The combination of the tank A, the bottom B, the tubular chamber C, having the elbow c, and the hinged flap f, and retained by the spiral spring f³, substantially as specified and set forth.

No. 56,331. Life-Guard for Street Cars. (Garde-corps pour chars de rue.)

(Garde-corps pour chars de rue.)

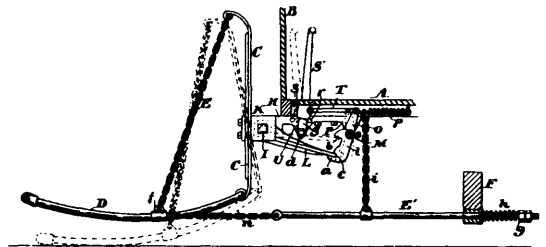

George Ashael Parmenter, Cambridge, Mass., U.S.A., 18th June, 1897; 6 years. (Filed 17th May, 1897.)

Claim.—1st. The combination of a rocker-shaft mounted in bearings on the end of a car, a pair of elliptic or leaf springs firmly secured to said rocker-shaft and projecting above and below the same, a fender or scoop pivoted to the lower ends of said springs and suspended by a suitable connection from their upper ends, a rearwardly projecting arm rigidly secured upon said rocker-shaft, a second rocker-shaft mounted in bearings beneath the car platform, a tumbler arm secured upon and pendent from said second rocker-shaft and provided with lugs a and b and the detent c, means for normally holding said tumbler arm in engagement with said rearwardly projecting arm to hold the scoop in raised position, and means for tripping said tumbler arm to permit the scoop to fall to the ground. 2nd. The combination of the rocker-shaft I, the leaf springs C C, secured to said shaft and projecting above and below the same with both the upper and lower ends thereof free to yield, the scoop D pivoted to the lower ends of said springs and suspended from the upper ends thereof and movable about its pivotal connection to said springs, means for locking said scoop in its normal raised position, means for disengaging said locking devices to permit said scoop to fall to the ground, and a yielding connection between the rear cross-rod of said scoop and the truck frame. 3rd. The combination of the rocker-shaft I, the springs C C, the scoop D, the suspension chains E, the arm L, the rocker-shaft M, the tubular arm l, the arm o, the spring p, the link T, the lever S, S¹, the pilot board F, the rod E¹ provided with a head or collar g, the spring h, and the flexible connection n, all constructed, arranged and operating substantially as described.

No. 56,332. Saluting Device. (Appareil à saluer.)



James C. Boyer, Spokane, Washington, U.S.A., 18th June, 1897; 6 years. (Filed 17th May, 1897.)

Claim.—1st. An automatic device for effecting salutations, comprising power-moved mechanism adapted for removable attachment on

the head of a person, and a device in the head gear of said person, actuated by the mechanism when the person bows, and operating to lift, turn and then lower the head gear, as specified. 2nd. An automatic device for effecting salutations, comprising a support, means for holding said support on the head of a person, spring-actuated gearing on the support, an attachment in the head-gear of said person adapted to rotate on the support, and means, substantially as described, for transmitting motion from the gearing to the head-gear attachment, whereby said head-gear is lifted, turned and lowered when the wearer bows, as specified. 3rd. In a device for effecting automatic salutations, the combination with a case of spring-actuated rotary gearing in and on said case, a clamping device on the case adapted to engage the head of a person, a lifting-arm, a gear-wheel outside of the case and on which the arm is carried, an attachment in the person's head-gear, the same being rotatably mounted on the case and clamped to the sweat-band of the head-gear, a vertically-slidable post, a laterally-projecting pin adapted to be engaged by the lifting-arm when said arm is swung around by the gearing, and means for normally restraining the gearing and adapted to release it upon the bowing of the head, as specified 4th. The combination of a clamp adapted to engage a person's head, a motor carried by said clamp and capable of operation to raise the hat from the head, and a trip normally restraining the motor and capable of operation to release the same, substantially as described. 5th. The combination of actuated gearing, two arms moving with said gearing, a vertically-movable guide-plate, a bar carried by and independently movable in said guide-plate, the bar being respectively adapted to be engaged by the arms, and means for controlling the arms, substantially as described. 6th. The combination of a motor, a guide-plate having a vertically-elongated depression, the upper edge of which is inclined, a bar movable longitudinally in the depression and having a pin adapted to receive the operative force of the motor, and means for controlling the motor, substantially as described. 7th. The combination of a motor, a guide-plate having a semi-circular inclined part at its upper portion, a bar movable on the guide-plate and having a pin adapted to receive the operative force of the motor, and means for controlling the motor, substantially as described. 8th. The combination with a frame, of a motor capable of operation to raise a hat, and a balanced trip normally restraining said motor, the trip being released when disturbed in its equilibrium by the rocking of the frame, substantially as described. 9th. The combination with a frame, of a motor, a longitudinally-movable bar, an arm actuated by the motor and capable of raising the bar, and a balanced trip normally restraining the arm, the trip being released when disturbed in its equilibrium by the rocking of the frame, substantially as described. 10th. The combination with a frame, of actuated gearing, an arm moving with said gearing, a longitudinally-movable bar capable of being lifted by the arm, means for restraining the operation of the arm, and a balanced weight the same being connected to actuate said means and being capable of rocking to release the arm by and upon the rocking of said frame, substantially as described.

No. 56,333. Materials for Incandescing Metals and Process of Manufacturing the Same.
(*Procédé de fabrication de pellicules incandescentes.*)

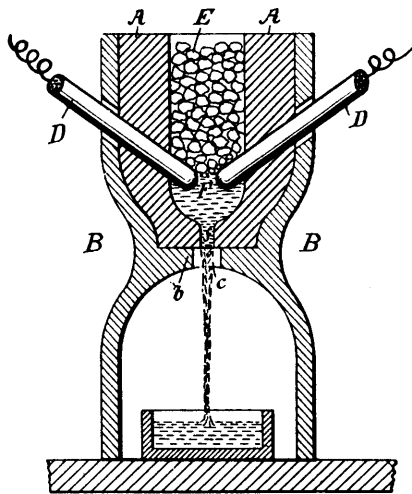

56333

The Canadian Sterling Light Company, Camden, assignees of W. L. Voelker, Elizabeth, New Jersey, both in U.S.A., 18th June, 1897; 6 years. (Filed 13th June, 1896.)

Claim.—1st. A material for use in making incandescing mantles, consisting of the oxides of magnesium and calcium, first combined in the proportions substantially as hereinbefore specified, and then

fused at high temperatures, substantially as and for the purpose hereinbefore set forth. 2nd. A material for use in the manufacture of incandescing mantles, consisting of the oxides of magnesium and calcium intimately mixed together in the proportions substantially as hereinbefore specified, and of traces of colour-producing mineral oxides, and all fused together at high temperatures, substantially as and for the purpose hereinbefore set forth. 3rd. The process of manufacturing materials for producing incandescence, consisting in mixing together the oxides of magnesium and calcium, substantially in the proportions hereinbefore specified, and then heating the combined minerals to a very high temperature, substantially as and for the purpose hereinbefore set forth. 4th. A material for the manufacture of incandescents consisting of the oxides of magnesium and calcium combined and fused in the proportions substantially as hereinbefore specified, and of a viscous carbonizable joining material, substantially as and for the purpose hereinbefore set forth.

No. 56,334. Heel Trimming and Randing Machine.
(*Machine à finir les talons de chaussures.*)

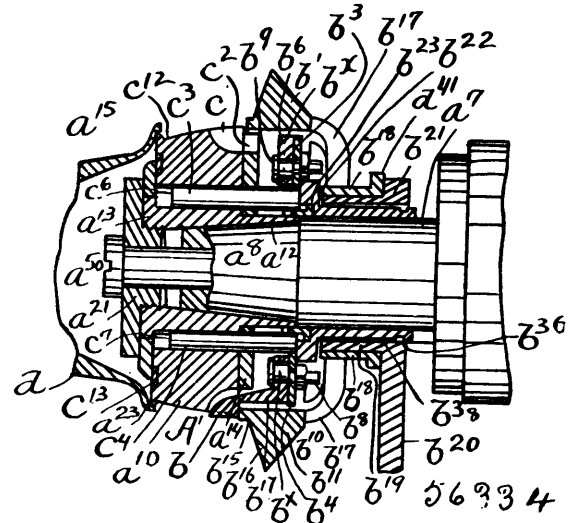

Ambrose Stevens Vose, Brookline, Mass., U.S.A., 18th June, 1897; 6 years. (Filed 25th May, 1897.)

Claim.—1st. In a heel-trimming machine, the combination of the following instrumentalities, viz., a rotary cutter provided with a heel-trimming knife or blade and with a rand knife or blade, and having a socket or pocket for the reception of an auxiliary heel-trimming knife or blade, a shaft upon which the said rotary cutter is mounted to rotate therewith, a top-lift guide movable with relation to the rotary cutter and disconnected from its shaft to revolve independently thereof, and the said auxiliary knife or blade co-operating with the said heel-trimming knife and movable axially with the said top-lift guide, the said auxiliary knife or blade being normally extended into the said socket or pocket, for the purpose specified. 2nd. In a heel-trimming machine, the combination of the following instrumentalities, viz., a rotary cutter consisting of a body or head of a width substantially equal to the height of the heel at its breast and provided with heel-trimming blades or knives of a width substantially equal to the width of the cutter head or body, a rand-knife carried by the said head or body, a rand-guard co-operating with the said rand-knife, a shaft upon which the said rotary cutter is mounted to rotate therewith, a top-lift guide movable axially away from the cutter head or body and disconnected from the said shaft, and an auxiliary heel-trimming knife movable axially with the said top-lift guide to act on the top-lift end of the heel not acted upon by the main heel-trimming knives, substantially as described. 3rd. In a heel-trimming machine, the combination of the following instrumentalities, viz., a rotary cutter of a width substantially equal to the height of the heel at its breast, a heel trimming knife of a width substantially equal to the width of the said rotary cutter, and a rand-knife carried by said cutter, a rand-guard co-operating with the said rand-knife, a shaft upon which said rotary cutter is mounted to rotate therewith, a top-lift guide movable bodily, axially and radially with relation to the said rotary cutter and disconnected from said rotary shaft, and an auxiliary heel-trimming knife movable axially with the top-lift guide to act on the top-lift end of the heel not acted upon by the main heel-trimming knife, substantially as described. 4th. In a heel-trimming machine, the combination of the following instrumentalities, viz., rotatable shaft, a rotary heel-cutter mounted on said shaft and having a fixed position thereon, a rand-knife movable with the said rotary cutter, a rand-guard co-operating with said rand-knife, a top-lift guide movable on the said shaft with relation to the rotary cutter and disconnected therefrom, an auxiliary knife-carrier independent of and detachably secured to the said top-lift guide,

and an auxiliary knife secured to said carrier and co-operating with said rotary heel-cutter, substantially as and for the purpose specified. 5th. In a heel-trimming machine, the combination of the following instrumentalities, viz., a rotary cutter provided with heel-trimming knives, a rotatable rand-knife having a fixed relation to the heel-trimming knives, a rand-guard having a fixed position with relation to the heel-trimming knives in its operative position and co-operating with the said rand-knife, an auxiliary heel-trimming knife provided with a shank or arm and co-operating with the main heel-trimming knife to form an extension of the top-lift end thereof, and a movable hollow or recessed top-lift guard normally close to the top-lift end of the main heel-trimming knife and extended over the shank or arm of the auxiliary knife, substantially as described. 6th. In a heel-trimming machine, the combination of the following instrumentalities, viz., a rotary heel-cutter provided with a heel-trimming knife or blade, a shaft on which said cutter is mounted to rotate therewith, a top-lift guide loosely mounted on the said shaft to revolve independent of said shaft and movable axially with relation to the said cutter and provided with an annular ledge or rim substantially in line with the cutting edge of the heel-trimming knives, and an auxiliary heel-trimming knife having its cutting edge in substantially the same line or plane as the cutting edge of the main heel-trimming knife and automatically movable axially with the top-lift guide and connected to the said rotary heel-cutter to rotate therewith, substantially as described. 7th. In a heel-trimming machine, the combination of the following instrumentalities, viz., a rotary cutter consisting of a head or body having its periphery of substantially the same contour as the finished heel, and provided with slots in its periphery, a plurality of main heel-trimming knives inserted in said slots and having their cutting edges of substantially the contour of the finished heel, a rand-knife revoluble with the said rotary cutter, a rand-guard co-operating with said rand-knife, a hollow or recessed top-lift guide movable bodily with relation to the rotary cutter, and an auxiliary heel-trimming knife having its shank or arm extended into the hollow or recessed top-lift guide and secured thereto to move therewith, and having its cutting edge adapted to form a continuation of the cutting edge of the main heel-trimming knife, substantially as described. 8th. In a heel-trimming machine, the combination of the following instrumentalities, viz., a rotary cutter consisting of a body or wheel provided with heel-trimming knives or blades, and a rand-knife inserted into a slot in the side or face of the said body or wheel and provided with a clearance-notch c^{15} , and means to move the said knife to adjust it with relation to the said body or wheel, substantially as described. 9th. In a heel-trimming machine, the combination of the following instrumentalities, viz., a rotary heel-cutter, a rand cutter, an auxiliary heel knife or blade co-operating with said heel-cutter, a carrier for said auxiliary heel knife or blade connected to the rotary heel-cutter to revolve therewith and movable bodily with relation to said rotary cutter, and means to adjust said auxiliary heel-knife in its carrier, substantially as described. 10th. In a heel trimming machine, the combination of the following instrumentalities, viz., a rotary cutter consisting of a body or wheel provided with peripheral knife-receiving slots, knives or blades inserted in said slots, a socket or pocket in the said body or wheel intermediate of the said knife-receiving peripheral slots, a shaft on which the said body or wheel is mounted to revolve therewith, an auxiliary knife or blade inserted in said socket or pocket, and a carrier for said auxiliary knife or blade loose on the said shaft but connected to said body or wheel to revolve therewith and movable bodily away from said body or wheel, substantially as described. 11th. In a heel-trimming machine, the combination of the following instrumentalities, viz., a rotary cutter consisting of a body or wheel provided with a peripheral knife-receiving slot extended across the said body or wheel, a main heel-trimming knife inserted in said peripheral slot, a shaft on which said body or wheel is mounted to revolve therewith, a separate and auxiliary heel-trimming knife co-operating with the main heel-trimming knife, and a carrier for said auxiliary knife loose on said shaft but connected to said body or wheel to revolve therewith and movable bodily away from the main heel-trimming knife, substantially as described. 12th. In a heel trimming machine, the combination of the following instrumentalities, viz., a rotary cutter consisting of a body or head provided with a heel-trimming knife having its cutting-edge of a width substantially equal to the height of the heel at its breast, and of a shape substantially the same as the contour of the finished heel, a rand-knife, a rand-guard co-operating therewith, a shaft on which said body is mounted to rotate therewith, an auxiliary heel-trimming knife separate from the main heel-trimming knife but co-operating therewith, a hollow or recessed top-lift guide movable bodily with relation to the rotary cutter and disconnected from the cutter-shaft, and means to connect the auxiliary heel-trimming knife to the said body or wheel and to the top-lift guide, substantially as and for the purpose specified. 13th. In a heel-trimming machine, the combination of the following instrumentalities, viz., a rotary cutter provided with a heel-trimming knife, a rand-knife, a rand-guard co-operating therewith, a shaft on which said cutter is mounted to rotate therewith, an auxiliary heel-trimming knife, a carrier for said auxiliary knife loose on said shaft and movable with relation to the rotary cutter, and means to connect the said carrier with the rotary cutter to cause the same to rotate simultaneously therewith and to guide the carrier in its movement away from the rotary cutter, substantially as and for the purpose specified. 14th.

In a heel-trimming machine, the combination of the following instrumentalities, viz., a rotary heel cutter provided with a heel-trimming knife, a shaft on which said cutter is mounted to rotate therewith, a top-lift guard loose on said shaft and movable axially on said shaft with relation to the cutter fast thereon, an auxiliary heel-trimming knife, a support for the said knife loose on said shaft but connected to said rotary cutter and to the top-lift guard, to revolve with the cutter without imparting rotation to the said top-lift guard, and yet axially movable with the said guard, for the purpose specified. 15th. In a heel-trimming machine, the combination of the following instrumentalities, viz., a rotary heel-cutter provided with a heel-trimming knife or blade, a shaft on which said cutter is mounted to rotate therewith, a top-lift guide loosely mounted on said shaft and radially and axially adjustable with relation thereto, and an auxiliary heel-trimming knife co-operating with the main heel-trimming knife and connected to the rotary heel-cutter to rotate therewith and to the top-lift guide to move axially with relation to the heel-cutter and to permit the top-lift guide to be adjusted radially without moving the auxiliary knife, substantially as described.

No. 56,335. Extension Table. (Table à rallonge.)

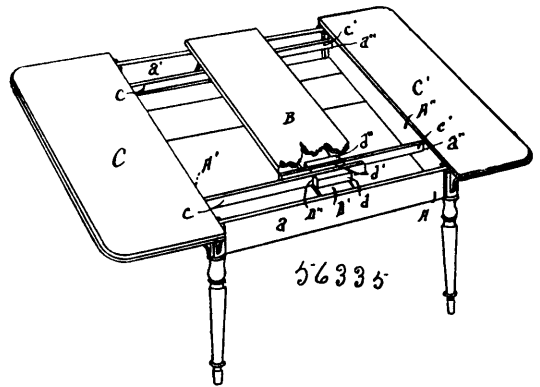

William H. Mays, Los Angeles, California, U.S.A., 18th June, 1897; 6 years. (Filed 19th May, 1897.)

Claim.—1st. In an extension table, the combination of the frame having the central or middle section rigidly secured thereto, the end or marginal sections each rigidly secured to slide bars arranged to reach, when the table is extended, from the end rails of the frame to the rigid middle section, each slide-bar being arranged to slide in two short guideways, one provided in the end rails and the other formed of blocks secured to the middle section, all of such guideways being adapted to allow the slides to slide endwise therein, but to prevent their movement in any other direction, substantially as and for the purpose set forth. 2nd. The combination set forth, of the frame having the middle section rigidly secured to its side rails, and having the dovetail guideways secured to the middle section, the dovetail slide-bars, each arranged to slide in one of the guideways in the end rails and in one of the guideways secured to the middle section, and the end or marginal sections secured to the slides, substantially as set forth. 3rd. The combination, of the frame having the middle section rigidly secured to its side rails, the middle guideways each formed of three blocks secured to the rigid middle section and having their opposing faces bevelled, and a bottom piece secured to the blocks, all arranged to form two short dovetail guideways, the end rails of the frame having the dovetail guideways provided therein, the dovetail slide-bars, each arranged to slide in one of the guideways of the middle section and one of the guideways of the end sections, and the end or marginal sections secured to the slide-bars, substantially as and for the purpose set forth.

No. 56,336. Sand Pump. (Moulin à sable.)

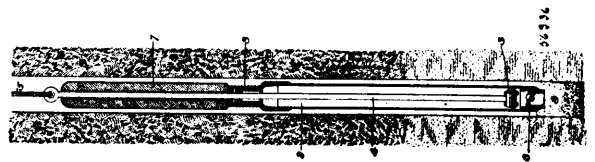

Fred Elliott Youngs, Allegheny, Pennsylvania, U.S.A., 18th June, 1897; 6 years. (Filed 19th May, 1897.)

Claim.—1st. A sand-pump comprising a pump-barrel, and a spring tending to force the pump-barrel downwardly. 2nd. A sand-pump for deep wells comprising a pump-barrel, a sinker and a spring.

No. 56,337. Construction of Plank Floors.
(*Construction de planchers en madriers.*)

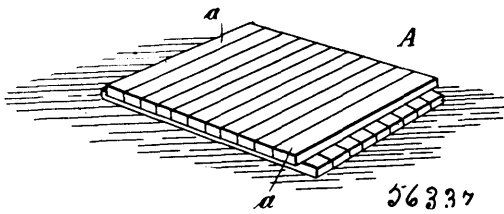

Oswald Kahnt, Sagan, Prussia, Germany, 18th June, 1897; 6 years.
(Filed 19th May, 1897.)

Claim.—1st. The improved wooden flooring without visible nails consisting of single squares, in which the two parallel edge pairs are constructed stepped in opposite directions, which squares are alternately secured through their projecting edges upon the beams, so that between every two of such squares a square is placed with its lower projecting edges under the stepped edges of the two neighbouring squares. 2nd. The wooden square applicable for the construction of the flooring as set forth in claim 1, consisting of two layers of narrow planks secured the one upon the other, in which layers the planks run at right angles to each other and project over each other at the ends.

No. 56,338. Burglar Alarm and Lock.
(*Serrure d'avertisseur d'effraction.*)

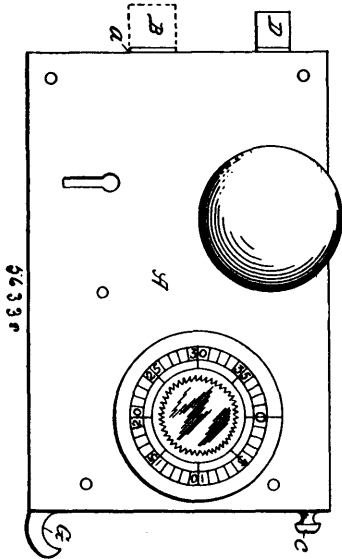

Simon Christopher Wolfe, Washington, Pennsylvania, U.S.A., 18th June, 1897; 6 years. (Filed 19th May, 1897.)

Claim.—1st. An improved combination alarm lock, consisting of a suitable case provided with a combination device which adapts the lock proper to be unlocked from the outside or inside without firing the alarm, said device consisting of a combination lock, a lever having a lug or projection adapted to enter recesses in discs of said combination lock, an arm pivotally secured to the locking bolt of the lock proper and adapted to engage with said lever, and an auxiliary wall for protecting the combination lock, dog, trip, levers and spring, a bolt for throwing the mechanism in or out of gear, and a bolt having a lateral movement for firing the alarm by pressure, in combination with a hammer for receiving a cartridge substantially as shown and described. 2nd. An improved combination burglar alarm lock, consisting of a suitable case, provided with a locking bolt, an arm or lever connected with said bolt and adapted to engage the end of a lever having a lug or projection, said lever being pivoted to a dog for engaging a hammer, and a trip movably secured in or to a support and adapted to engage said dog, a lever and spring for holding the same in contact with the locking bolt, a bolt for throwing the mechanism in or out of gear, and a combination device consisting of permutation discs provided with recesses to be engaged by the said lug or projection, in combination with said mechanism for unlocking the lock proper from the outside or inside without firing the alarm, substantially as shown and described.

No. 56,339. Sap Spout. (*Gargouille à sive.*)

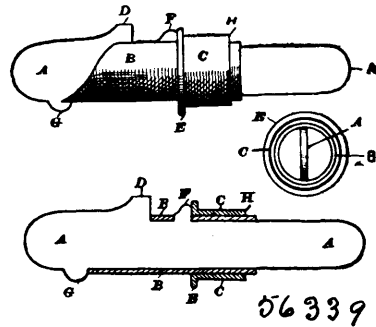

Hiram A. Lawrence, Farnham, Brome, Quebec, Canada, 18th June, 1897; 6 years. (Filed 20th May, 1897.)

Claim.—1st. In combination with any sap spout, a double or sectional seat to prevent leakage as herein set forth. 2nd. In combination with any sap spout, a binding thimble or tube strengthener, as described and shown. 3rd. In combination with any sap spout, a water and tree-wash excluder, as and for the purpose herein set forth.

No. 56,340. Steam Generator. (*Générateur à vapeur.*)

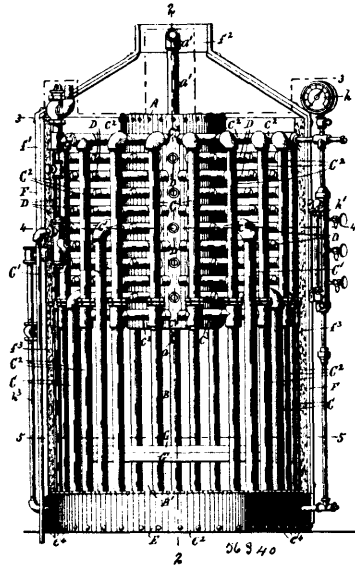

Deyo Samuel Worden, East Penfield, New York, U.S.A., 18th June, 1897; 6 years. (Filed 20th May, 1897.)

Claim.—1st. In a generator, the combination of a drum A supported above the combustion-chamber B, upright heads C arranged at the side of the combustion-chamber A, connections or pipes c for connecting the upper ends of the heads C to the drum A, additional upright heads C² arranged at the side of the combustion-chamber and extending above the heads C, and connection or pipes c², c³, arranged above and beneath the connections or pipes c and connected to the drum A and to the additional heads C², substantially as and for the purpose described. 2nd. In a generator, the combination of a drum A supported above the combustion-chamber B, upright heads C arranged at the side of the combustion-chamber A, connections or pipes c for connecting the upper ends of the heads C to the drum A, additional upright heads C² arranged at the side of the combustion-chamber and extending above the heads C, connections or pipes c², c³ arranged above and beneath the connections or pipes c and connected to the drum A and to the additional heads C², and tubes D projecting outwardly from the drum A between the connections or pipes c, c², c³, and formed with closed outer ends, substantially as and for the purpose specified. 3rd. In a generator, the combination of a drum A supported above the combustion-chamber B, upright heads C² arranged at the side of the combustion-chamber B and extending upwardly therefrom and having their upper ends and intermediate portions connected to the drum A, and tubes D formed with closed outer ends and projecting outwardly from the drum A, substantially as and for the purpose described. 4th. In a generator, the combination of a water-containing base E, a drum A supported above the combustion-chamber B, upright heads C² arranged at the side of the combustion-chamber A and

having their lower ends connected to the base E and their upper ends extended above the combustion-chamber B, water-connections c^2 , c^3 between the drum A and the upper ends and the intermediate portions of the heads C^2 , and tubes D extending laterally from the drum A between the water-connections c^2 , c^3 , substantially as and for the purpose specified. 5th. In a generator, the combination of a drum A supported above the combustion-chamber B, upright heads C^1 arranged at the side of the combustion-chamber B and extending upwardly therefrom and having their upper ends connected to the intermediate portion of the drum A, and tubes D formed with closed outer ends and projecting outwardly from the drum A above the heads C^1 , substantially as and for the purpose set forth. 6th. In a generator, the combination of a water-containing base E, an upright drum A supported above the combustion-chamber B, upright heads C, C^1 , C^2 of unequal length arranged at the side of the combustion-chamber B and having their lower ends connected to the base E, and their upper ends provided with laterally extending connections opening, respectively, into the top, the intermediate portion, and the base of the drum A, and tubes D formed with closed outer ends and projecting outwardly from the drum A between the connections of said heads, substantially as and for the purpose described. 7th. The herein described water-containing base E for a generator, the same consisting of a bottom well e^1 having a downturned flange e^2 at its outer edge, a top wall e provided with a downturned flange e^2 at its outer edge lapping upon the former flange e^2 , and forming the side wall of the base, and rivets e^4 passed through the flanges e^2 , e^3 , substantially as and for the purpose specified. 8th. In a generator, the combination of a drum A supported above the combustion-chamber B, upright heads arranged at the side of the combustion-chamber B and extending upwardly therefrom and having their upper portions connected to the drum A, the lower ends of two of the heads being separated a greater distance than the corresponding ends of the remaining heads, a shell F enclosing said drum and upright heads and formed with an opening f^4 therein aligned with the space between said two of the heads, a grate-support G^1 arranged within the shell F and enclosed by the upright heads, said grate-support consisting of a split ring formed of less height than the opening f^4 and having its opposite ends detachably secured together, substantially as and for the purpose set forth. 9th. In a generator, the combination of a drum A supported above the combustion-chamber B, upright heads C^2 arranged at the side of the combustion-chamber B and extending upwardly therefrom and having their upper ends and intermediate portions connected to the drum A, and an enclosing shell F consisting of vertical sections f , f^1 , removably secured together for permitting access to the heads C^2 , substantially as and for the purpose described.

No. 56,341. Combination Sad Iron and Heater.

(*Fer à repasser et chauffeur.*)

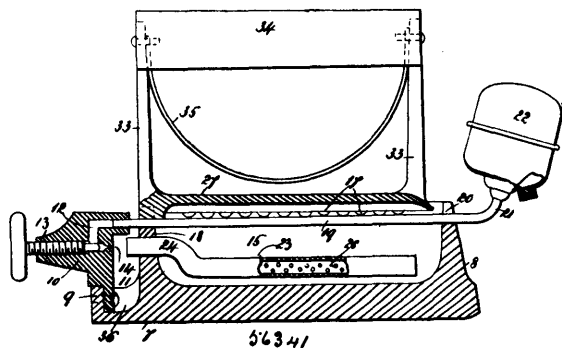

DeLeonard Rugg, Catskill, New York, U.S.A., 18th June, 1897; 6 years. (Filed 20th May, 1897.)

Claim.—1st. In a device of the character herein described, a base or iron provided in the top thereof with a longitudinal chamber, a burner tube mounted in said chamber, and provided with an angular arm or extension which projects through the rear wall thereof, said burner tube being adapted to be turned so that it will be adjacent to the bottom of said chamber or to the top thereof, an oil supply pipe which extends longitudinally through said chamber near the top thereof, and which projects through the end walls of said chamber, a valve casing secured to the rear end of the base or iron and provided with an angular chamber with which said pipe communicates, said angular chamber being also provided with a port or passage which opens rearwardly of the arm or extension of the burner tube, substantially as shown and described. 2nd. In a device of the character herein described, a base or iron provided in the top thereof with a longitudinal chamber, a burner tube mounted in said chamber and provided with an angular arm or extension which projects through the rear wall thereof, said burner tube being adapted to be turned so that it will be adjacent to the bottom of said chamber or to the top thereof, an oil supply pipe which extends longitudinally through said chamber near the top thereof, and which projects through the end walls of said chamber, a valve

casing secured to the rear end of the base or iron and provided with an angular chamber with which said pipe communicates, said angular chamber being also provided with a port or passage which opens rearwardly of the arm or extension of the burner tube, and said burner tube being provided with perforations, substantially as shown and described. 3rd. In a device of the character herein described, a base or iron provided in the top thereof with a longitudinal chamber, a burner tube mounted in said chamber and provided with an angular arm or extension which projects through the rear wall thereof, said burner tube being adapted to be turned so that it will be adjacent to the bottom of said chamber or to the top thereof, an oil supply pipe which extends longitudinally through said chamber near the top thereof, and which projects through the end walls of said chamber, a valve casing secured to the rear end of the base or iron and provided with an angular chamber with which said pipe communicates, said angular chamber being also provided with a port or passage which opens rearwardly of the arm or extension of the burner tube, and said burner tube being provided with perforations, and said longitudinal chamber being provided with a detachable cap or cover, substantially as shown and described. 4th. In a device of the character herein described, a base or iron provided in the top thereof with a longitudinal chamber, a burner tube mounted in said chamber and provided with an angular arm or extension which projects through the rear wall thereof, said burner tube being adapted to be turned so that it will be adjacent to the bottom of said chamber or to the top thereof, an oil supply pipe which extends longitudinally through said chamber near the top thereof, and which projects through the end walls of said chamber, a valve casing secured to the rear end of the base or iron and provided with an angular chamber with which said pipe communicates, said angular chamber being also provided with a port or passage which opens rearwardly of the arm or extension of the burner tube, and said burner tube being provided with perforations, and said longitudinal chamber being provided with a detachable cap or cover being provided with upwardly directed arms, to which the handle is secured, substantially as shown and described.

No. 56,342. Pipe Coupling. (*Joint de tuyaux.*)

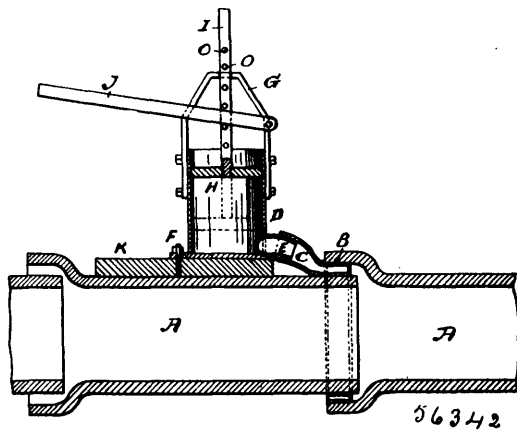

Gustav Lehlback, Newark, New Jersey, U.S.A., 18th June, 1897; 6 years. (Filed 20th May, 1897.)

Claim.—1st. In a device for filling the joints of connecting pipe sections with cement, the combination with the receptacle D, having an open upper end adapted to allow the withdrawal of the piston, the bail fastened to said receptacle at its opposite sides and turned over and above the open end of the receptacle, a piston separable from said receptacle, a piston rod having said piston at one end and at its upper opposite end bearing at one of its sides against one side of the bail and at its opposite side provided with a series of bearings, and a hand lever fulcrumed upon said bail and adapted to press against the side of the piston rod and hold it against the bail when forcing down the piston, substantially as set forth. 2nd. The combination with a receptacle for fluid cement mortar, a piston and means for operating the same, a duct from said receptacle, and a textile cover pervious to air in connection with said duct and adapted to be applied to the pipe joint, substantially as set forth. 3rd. The combination with a receptacle for fluid cement mortar, a piston and means for operating the same to force the fluid cement mortar from said receptacle, a duct of porous textile fabric in connection with said receptacle to receive the mortar therefrom and a textile cover adapted to be fastened over the pipe joint, said parts being arranged and adapted to operate substantially as set forth. 4th. In a device for filling the joints of connecting pipe sections with cementitious matter, the combination with the mortar receptacle D, separate and independent of the said sections, a cover adapted to extend around the pipe and convey the mortar into the joint formed by said sections, a duct connecting said receptacle and cover, a bail serving as a guide or bearing, a piston, a piston rod extending from said piston to said bail and having a bearing o , and a lever fulcrumed on said bail and engaging said piston rod to de-

press the same, substantially as set forth. 5th. In a device for filling the joints of connecting pipe sections with fluid cementitious matter, the combination with the receptacle D, having an open upper end, a spout at its lower end, and a bail extending over and above said open end and recessed to receive the piston rod, a piston, a piston rod, extending from said receptacle upward through said open end of the receptacle and engaging the said bail, a lever engaging the piston rod, and means for transmitting the fluid cementitious matter to the joint under pressure, substantially as set forth. 6th. In a device for filling the joints of connecting pipe sections with fluid cementitious matter, the combination with the receptacle D, separate from and independent of the pipe sections, and having an open upper end adapted to allow the withdrawal of the piston, a bail extending over said open end, a piston separable from said receptacle, a piston rod having a series of bearings, and adapted to press against said bail, a duct leading from said receptacle to said pipe section and a cover for conveying the cementitious matter around the joint under pressure of said piston, substantially as set forth. 7th. In a device for filling the joints of connecting pipe sections with solidifiable cementitious fluid, the combination with a cylindrical receptacle D, separate from and independent of the pipe sections, mounted upon a bed plate K, and, at its upper end, having an opening to allow the insertion of the mortar and the withdrawal of the piston, a bail extending over and above said opening, a piston and its rod the latter bearing at one side of said bail, a lever bearing against said piston rod at the side opposite that engaged by the bail, a duct leading from the receptacle to the pipe sections, and a cover, all said parts being arranged and combined substantially as set forth. 8th. The combination with a cylinder, independent of and separable from the pipe sections, its piston and means for operating said piston in said cylinder, a duct leading from said cylinder to said pipes, and a band-like cover of textile fabric adapted to be fastened over the joint formed by the meeting ends of the pipe sections, and form a receptacle with said meeting ends, substantially as set forth. 9th. The device for filling the joints of pipes with cementitious matter consisting of a receptacle D, separate from and independent of the pipe and open at its upper end, a bail extending over and considerably above the open end, of said receptacle, a lever fulcrumed at one side of said bail, a piston working within the receptacle and bearing on said bail, a piston rod, a series of lateral projections, said lever being loosely fulcrumed to allow a free transfer from bearing to bearing, a duct and means for leading the cementitious matter around the pipe, substantially as set forth. 10th. The combination with the cylindrical receptacle for mortar separable from and independent of the pipes, a duct consisting of flexible textile fabric leading to a cover adapted to surround the pipe at the joint formed by the sections, said cover consisting of a band of textile fabric adapted to be bound around the pipe over the joint to close the same, and a piston and means for operating the same, all arranged and operating substantially as set forth. 11th. In a device for filling the joints of connecting pipes with a solidifiable cementitious fluid, the forcing apparatus comprising a cylinder, open at its lower end to allow an ejection of the fluid under pressure, and open at its upper end to allow the removal of the piston, a piston hugging the walls of said cylinder and removable from said cylinder through said upper openings, a bail or guide G, extending over said open upper end, a piston rod having a series of projections at one side and bearing on said bail at the other, and a lever loosely fulcrumed on said bail and movable laterally away from the piston rod to admit free transfer from one projection to the next, said parts being arranged and combined substantially as set forth.

No. 56,343. Coach and Car Step.

(*Marches de chars et carrosses.*)

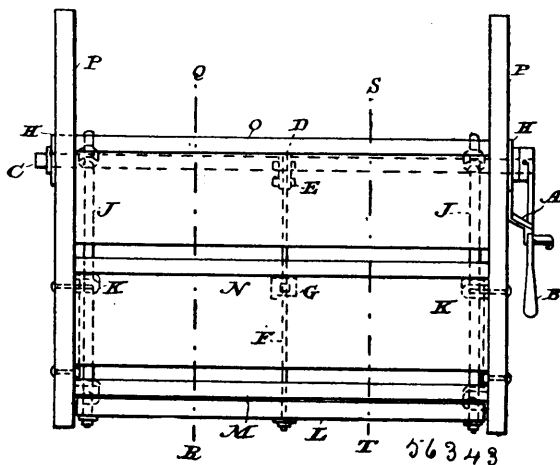

Frederick Augustus Taylor, Patrick Williams Farrell and Wesley Solomon Quebe, all of Galveston, Texas, U.S.A., 18th June, 1897; 6 years. (Filed 20th May, 1897.)

Claim.—In combination, the step frame with the stationary steps, the movable step L, the guide bars J, extending up at an angle from the ends of the movable step, the guides K, on the step frame for the two bars J, a central operating rod F, extending up at an angle, the guide G, on one of the stationary steps for the bar F, and the rock shaft c, with the arm D, and toggle E, connected with the bar F, the said operating rod having sliding movement only in its guides, which is permitted by the lever and link connection, and the said rock shaft being journalled in the corner of the step with the operating arm D extending rearwardly therefrom, substantially as described.

No 56,344. Heating Apparatus.

(*Appareil de chauffage.*)

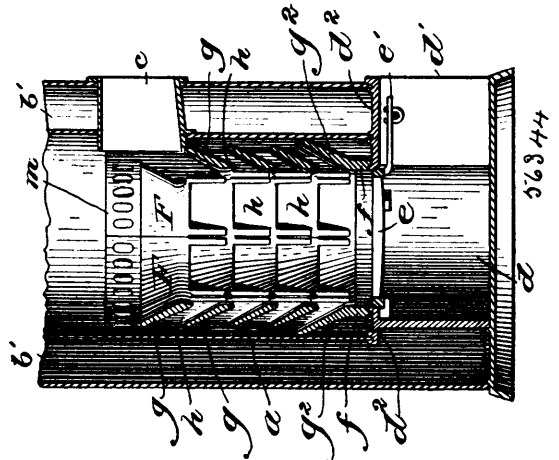

Charles Joseph Ridgway, Winthrop, Mass., U.S.A., 18th June, 1897; 6 years. (Filed 20th May, 1897.)

Claim.—1st. A fire-box composed of a series of downwardly and inwardly inclined plates located one above the other and separated by air spaces, substantially as described. 2nd. A fire-box composed of a series of sections, as f, each section being composed of a foot, a series of downwardly and inwardly inclined plates g, said sections being adapted to be set side by side to thereby form a suitable fire-box, substantially as described. 3rd. The combination with a body and grate, of a heater, of a fire-box composed of a series of superimposed downwardly and inwardly inclined plates separated by air spaces, all of said plates with the exception of the lowermost one of the series being removed at their outer edges from the inner side of the said body, the lowermost of said series of plates being wider to contact with the inner side of said body, and prevent the entrance of air into said space except from the fire-box, and to direct back into the fire-box any ashes, soot, &c., entering the space between the fire-box and the said body, substantially as described.

No. 56,345. Non-refillable Bottle.

(*Appareil pour empêcher le remplissage des bouteilles.*)

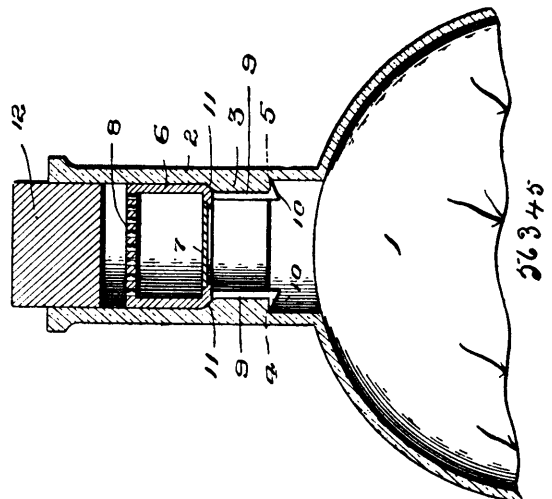

George H. Knaust, New York, State of New York, U.S.A., 18th June, 1897; 6 years. (Filed 21st May, 1897.)

Claim.—1st. In a non-refillable bottle, the combination of a bottle neck having an annular enlargement therein, and a valve-seat con-

sisting of a tubular body with a valve in the lower portion thereof and provided with a forminate cap, said body also having depending spring-arms, and lower shouldered ends and adapted to engage the annular enlargement, substantially as and for the purpose specified. 2nd. In a non-refillable bottle having a valve-seat consisting of a tubular body with a valve in the lower portion thereof, and an upper forminate cap, substantially as and for the purpose specified.

No. 56,346. Ironing Boards, Ladders and Benches.
(Table à répasser echelle et banc.)

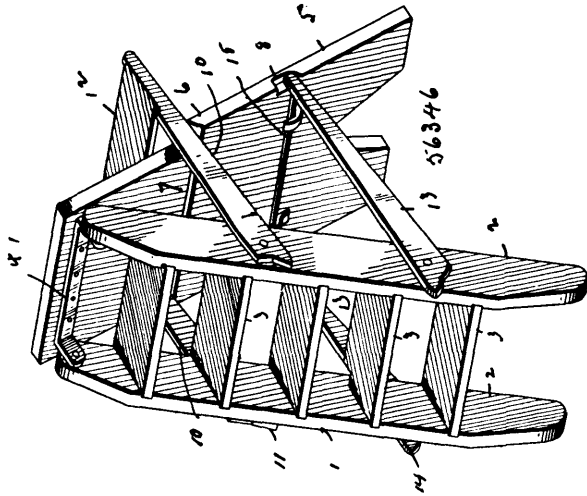

Ross Victor Inghish, Tawas, Michigan, U.S.A., 13th June, 1897; 6 years. (Filed 21st May, 1897.)

Claim.—1st. The combination of a ladder, a board pivoted to the upper end thereof, having its side edges cut away at their upper ends, forming shoulders and having stops upon its inner surface, a frame pivoted to said ladder having a rung or cross-bar in its outer end adapted to engage said stops for preventing the contraction or separation of said board and ladder, and a second frame having a strip constituting a pan support at its outer end, the second frame being pivoted to said ladder and adapted to rest upon the shoulders of said board. 2nd. The combination of a pair of beams, a board pivoted to one end thereof having shoulders formed in its outer edges and a pair of frames also pivoted to said beams, the inner ends of the side bars of said frames having pointed projections thereon adapted to engage said shoulders, substantially as and for the purpose described. 3rd. In a device of the character set forth, the combination with a ladder having two parallel side beams, of a board pivoted to the upper ends of said beams, the said board having its edges cut away at points adjacent to its pivotal connection with said beams, forming shoulders thereon, the said board being further provided with a transverse groove on its inner surface and with stops at its lower end and also having notches in its outer edges forming shoulders thereon, a frame pivoted to said beams near the upper ends thereof, having a flat strip connecting the side bars thereof at one end and having the opposite ends of said side bars formed with teeth or projections thereon, and a second frame pivoted to said beams at points near their opposite ends, the side bars thereof being connected by a rung or rod at one end and having their opposite ends formed with projections, substantially as and for the purpose described.

No. 56,347. Harvester Cutter Bar.
(Souche de lames de moissonneuses.)

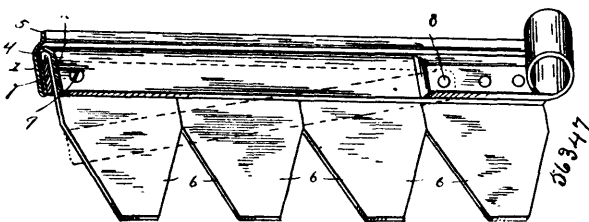

William E. Ball and Alice C. Bailey, both of Zanesville, Ohio, U.S.A., 18th June, 1897; 6 years. (Filed 22nd May, 1897.)

Claim.—1st. A cutter bar formed of three layers of sheet metal, two of said layers having an opening between them to receive the cutters, and the third layer extending rearward to prevent rocking when the cutter-bar is in motion, substantially as described. 2nd. A cutter-bar formed of sheet metal bent into three folds, one of which extends in the rear of the cutter-bar proper to prevent rock-

ing when in motion, substantially as described. 3rd. A cutter-bar formed of sheet metal bent into three folds, and having its lower end bent upward and then outward to form a flange, substantially as described.

No. 56,348. Hanger for Shade Rollers.
(Porte-rideau de fenêtre.)

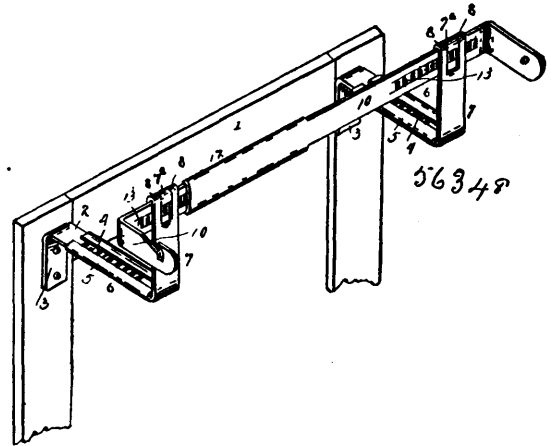

Julius W. Crigler, Bloomington, Illinois, U.S.A., 18th June, 1897; 6 years. (Filed 22nd May, 1897.)

Claim.—1st. In a shade hanger, the combination with the angular brackets adapted to be secured to a window-sash, of the extensible angular brackets connected therewith, the three vertical arms at the upper ends thereof, the central one of which is formed with a bend, so that it will be in a different plane from the other two, and the ends of said arms being bent or curved inwardly forming ways, and the overlapping adjustable hanger-bars, seated in said ways, substantially as described. 2nd. In a shade hanger, the combination with the angular brackets adapted to be secured to a window-sash, of the angular extensible brackets having inwardly turned flanges engaging therewith, the arms in different planes at the upper ends of said extensible brackets, and one of said arms of each bracket formed with a projection, the overlapping adjustable hanger-bars having depressions coinciding with said projections and one of said bars formed with flanges overlapping the other bar, substantially as described.

No. 56,349. Derrick. (Grue.)

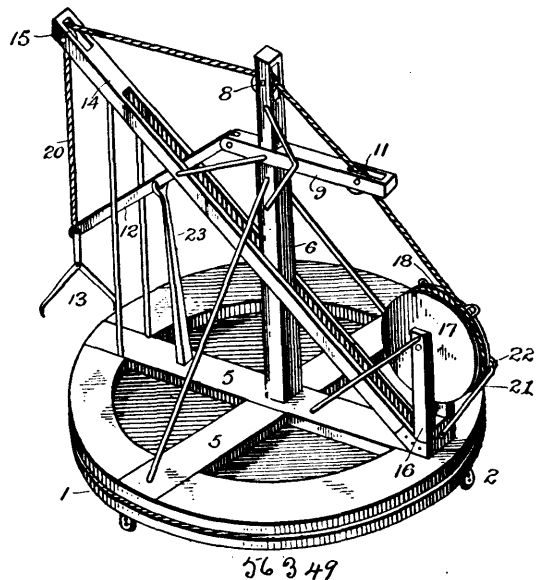

George Vassar Stallings, Scrawn, Texas, U.S.A., 18th June, 1897; 6 years. (Filed 22nd May, 1897.)

Claim.—1st. The combination with a base piece, of a derrick frame mounted to rotate thereon, an upright rising centrally from said derrick frame having a roller in the upper end or extension thereof, a cross beam on said upright having an opening in its outer end in which is mounted a roller, a steadying lever pivoted to the

opposite end of said cross beam, a bracing beam having bifurcated ends secured to the lower part of said derrick frame and extending upwardly therefrom diagonally, the arms thereof surrounding said upright and said steadying lever, a roller in the upper end of said bracing beam, a basket or gripping device secured to the outer end of said steadying lever, a drum mounted to rotate in said derrick frame and a cord attached to said drum, passing around the rollers in said cross beam, said upright and said bracing beam and attached at its outer end to said steadying lever, substantially as and for the purpose described. 2nd. The combination with a base piece mounted upon rollers, of a derrick frame mounted to rotate thereon and having anti-friction rollers on the under side thereof, an upright rising centrally from said derrick frame having a gudgeon upon its lower end which projects through the bottom of said derrick frame and fits an opening in said base piece, constituting the pivot upon which said derrick frame rotates, a roller mounted in the upper end or extension of said upright, a cross beam on said upright having an opening in one end in which is mounted a roller, a steadying lever pivoted to the opposite end of said cross beam, a basket or gripping device attached to the outer end of said lever, a bracing beam having bifurcated ends attached to the lower part of said frame and extending diagonally therefrom, the arms thereof surrounding said upright and said steadying lever, a roller in the upper end of said bracing beam, a drum having a peripheral groove therein mounted to rotate in uprights secured to one side of said derrick frame, handles upon the outer edge of said drum having openings therethrough, a stop bar having an inturned outer end adapted to fit within the opening in one or the other of said handles, and a cord attached to said drum, passing around the rollers in said cross beam, said upright and said bracing beam, and attached at its outer end to said steadying lever, substantially as and for the purpose described.

No. 56,350. Pump. (*Pompe foulante et aspirante.*)

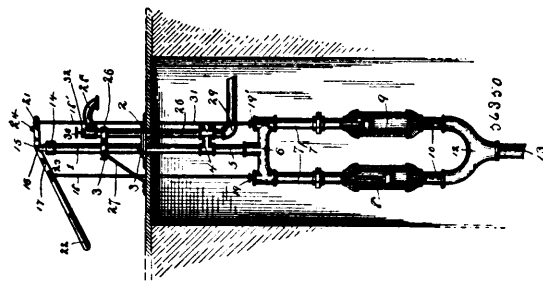

Charles Garfield Hayes, Tiskilwa, Illinois, U.S.A., 21st June, 1897; 6 years. (Filed 22nd May, 1897.)

Claim.—A duplex pump comprising the tubular standard 1, the cap-bracket 14, secured to the upper end thereof and provided with the integral vertical parallel arms 15-15, the case or box 4, secured to the lower end of said standard, the three-way yoke 6, provided with the stuffing boxes 19-19¹, the vertical pipe 5, connecting said case and yoke 6, the pump cylinders 8 and 9, the parallel pipes 7-7, connecting said cylinders independently to said yoke, the Y-fitting 12, the parallel pipe 1, 10¹, connecting the lower ends of said cylinders with said fitting and the suction pipe 13, depending from said fitting, in combination with the elbow 23, and the discharge pipe 25, communicating with the case 4, a horizontal disc valve mounted in said case and adapted to alternately close the contiguous end of the elbow or discharge pipe, means substantially as described for operating said valve, the lever 17, fulcrumed in the cap-bracket 14, and provided with the detachable handle 22, and the connecting rods 18-18¹, connecting said lever with the pistons in the cylinders 8-9, as and for the purpose set forth.

No. 56,351. Carriage Jack.

(*Chèvre de voitures.*)

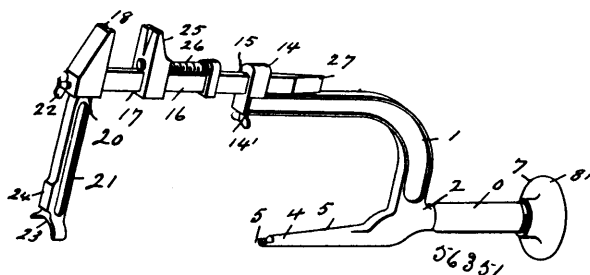

Charles Edward Thompson, Leesburg, Virginia, U.S.A., 21st June, 1897; 6 years. (Filed 22nd May, 1897.)

Claim.—1st. A carriage-jack of the class described, comprising the brace 1, formed with the integral socket 14, having set-screw

14¹, the socket 2, and the spindle 3, and the removable tubular handle 6, the wrench 17, provided with the shank 16, the sliding jaw 25, and the rigid jaw-head 18, having recess 19, and the detachable arm 21, formed with the integral bearing 23, and the shoulder 24, substantially as and for the purpose set forth. 2nd. A jack of the class described, formed with the integral socket 2, the removable tubular handle 6, having the screw-cap 7, provided with the flange 8¹, and the recess 8, the piston 12, and the screw-threaded rod 19, having a handle 9, substantially as and for the purpose set forth.

No. 56,352. Valve for Steam Engines.

(*Soupape pour machines à vapeur.*)

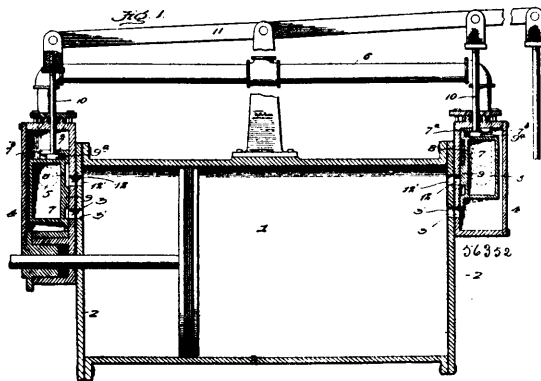

Daniel Webster Branch, Montgomery, Alabama, U.S.A., 21st June, 1897; 6 years. (Filed 22nd May, 1897.)

Claim.—1st. The combination with the cylinder of a steam engine having ports at its ends, which alternately act as inlet and outlet ports, of valve boxes at the ends of the cylinder having inlet and outlet pipes, and ports corresponding to those in the heads of the cylinder, slide valves having open sides and open ends, and provided on their upper edges with strips having slots, and valve rods having cross heads at their lower ends which engage said slots, and means for alternately reciprocating said valve rods, substantially as set forth. 2nd. The combination with the cylinder of a steam engine having ports at its ends, which alternately act as inlet and outlet ports, of valve boxes at the ends of the cylinder having inlet and outlet pipes, and ports corresponding with those in the heads of the cylinder, slide valves having open sides and open ends, and provided on their upper edges with strips having slots, and vertically adjustable valve rods having cross heads at their lower ends, which engage said slots, and means for alternately reciprocating said valve rods, substantially as set forth.

No. 56,353. Windlass. (*Treuil.*)

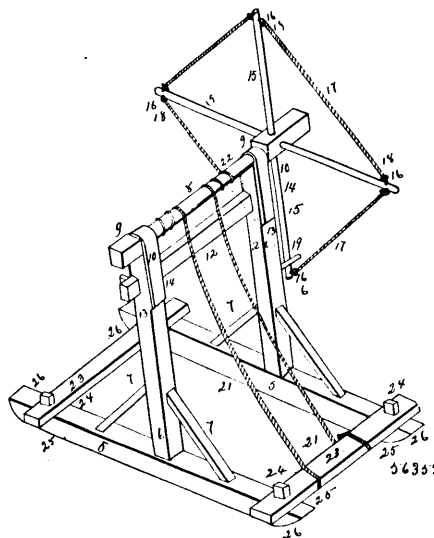

Charles Douglass Lee, Salmon, Idaho, U.S.A., 21st June, 1897; 6 years. (Filed 22nd May, 1897.)

Claim.—1st. The portable windlass, comprising the base rails provided with the rigid uprights, having semi-circular bearings in their

upper ends for the main shaft, which is rotatably secured therein by the straps secured to the cross-brace and uprights by removable pins, substantially as and for the purpose specified. 2nd. The portable windlass, comprising the base rails 5, 5, having the recesses 25 in its bevelled ends, in which are secured the cross braces 23, 23¹ by pins 24, having shoulders 28, and the uprights 6, 6, provided with the rectangular recesses 13 and cross-brace 12 secured therein by pins 14, and having the semi-circular bearings 9, in which is journalled a shaft 8, having the straps 10 secured by said pins 14, said shaft 8 being provided with flexible ropes or chains 21 extending to the brace 23, and having its outer end provided with radial arms 15, having holes 16 through which passes a hand rope 17, having knots 18, on each side of the holes 16, and the locking pin 19 removably secured in a hole 20 in the upright 6¹, substantially as and for the purpose specified.

No. 56,354. Claw Bar. (Barre à griffes.)

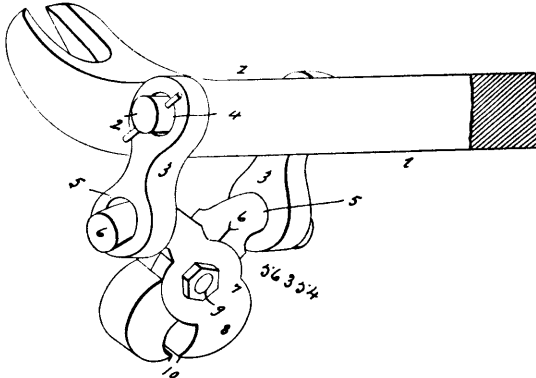

John Lindgren, Porter's Mills, Wisconsin, U.S.A., 21st June, 1897; 6 years. (Filed 22nd May, 1897.)

Claim.—The bar 1 provided with the transverse bolt 2, the links 3, 3 swivelled thereto, in combination with the grip-vise 7, the curved arms 6, 6 of which engage the orifices or eyes in the lower ends of said links, substantially as described.

No. 56,355. End Gate for Wagons.

(Arrière-panneau de tombeau.)

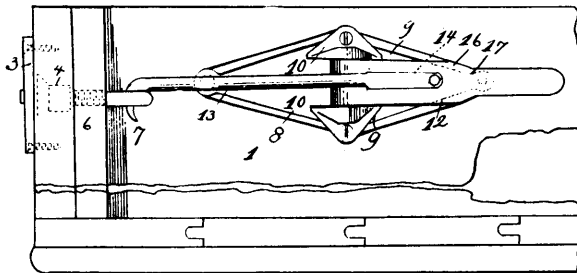

56355

William Herbert Arner, Groveland, New York, U.S.A., 21st June, 1897; 6 years. (Filed 22nd May, 1897.)

Claim.—1st. The socket 3 provided with the eye bolt 7, in combination with the plate 8 having integral parallel arms 9, 9, the lever 12 having its bifurcated ends 10, 10 fulcrumed in said arms, and provided with the horizontal hook 13, substantially as and for the purpose set forth. 2nd. The socket 3 having an integral internally screw-threaded shank 4, the eye bolt 7, the threaded end 6 of which is adjustably secured in said socket, in combination with the hand lever 12, having its bifurcated end fulcrumed in the arms 9, 9 of the plate 8, and the horizontal hook 13, pivoted at one end between the bifurcated ends of said lever and its free end adapted to engage the bolt 7, substantially as shown and described. 3rd. The socket 3, having internally threaded shank 4, the eye bolt 7 adjustably secured therein, in combination with the lever 8, having its end fulcrumed in the arms 9, 9 of the plate 8, the hook 13 pivoted at one end to said lever, and having its free end in contact with said eye bolt, and the spring 16 secured at one end to said lever and having its free end in operative contact with said eye bolt, substantially as shown and described.

No. 56,356. Corset Fastening.

(Appareil pour assujétir les corsets.)

Carl John Holmgren, Minneapolis, Minnesota, U.S.A., 21st June, 1897; 6 years. (Filed 22nd May, 1897.)

Claim.—1st. The combination with the bifurcated lever A, fulcrumed to the shoe B, of the lever D, fulcrumed between the arms

of said bifurcated lever, and formed with a hooked end E, terminating in a toe c, provided with a recess c¹, substantially as and for

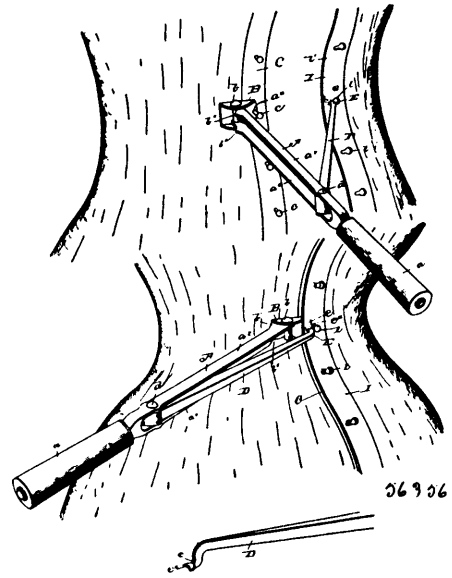

56356

the purpose set forth. 2nd. The bifurcated lever A, provided with a handle a, lugs b¹, b¹, and fulcrumed to the shoe B, formed with a recess a¹, in combination with the lever D, fulcrumed between the arms a², a², of said lever A, and having its free end terminating in a hook E, provided with a toe c, formed with a recess c¹, substantially as and for the purpose set forth. 3rd. In a device for fastening corsets upon the person, a lever provided with a handle and a shoe pivoted thereto, in combination with an auxiliary lever pivoted to the former, and having its free end terminating in a hook formed with a stud engaging a recess, substantially as and for the purpose set forth.

No. 56,357. Rotary Trimming Machine.

(Machine à recéper rotative.)

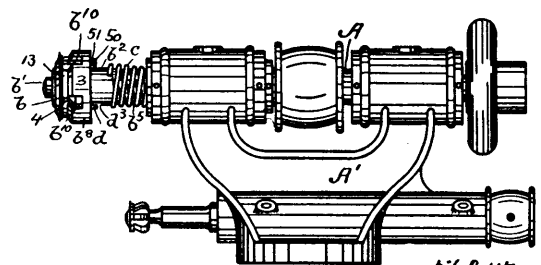

56357

Ambrose Stevens Vose, Brookline, Mass., U.S.A., 21st June, 1897; 6 years. (Filed 25th May, 1897.)

Claim.—1st. In a rotary trimming machine, the combination of the following instrumentalities, viz:—A rotary shaft, a cutter head or wheel carried thereby to rotate therewith and provided with a periphery of different diameters to form a bed narrower than the width of the cutter head, cutters or knives carried by said head and co-operating with said bed, and a guard longitudinally movable on the said shaft and embracing or fitted over the portion of the periphery of smaller diameter, substantially as and for the purpose specified. 2nd. In a rotary trimming machine, the combination of the following instrumentalities, viz:—In a rotary shaft, a cutter head or wheel carried thereby to rotate therewith and having its periphery reduced in diameter from one side toward the opposite side for a portion of its width to form a narrow bed 13, and the reduced portion 14, knives or cutters carried by said head and co-operating with the said bed, and an automatically adjustable guard fitted over the reduced portion 14 of the cutter head, substantially as and for the purpose specified. 3rd. In a rotary trimming machine, a cutter head or wheel having its periphery reduced in diameter from one side toward the opposite side for a portion of the width of the cutter head or wheel to form a narrow bed 13, slots or openings in said wheel extended across the periphery of the same and interrupting the continuity of the bed, cutters or knives in said slots having inclined cutting lips 2, 3, and an intermediate convex cutting edge 4 co-operating with the bed 13, and means to secure the said knives to the said head or wheel, substantially as described

4th. In a rotary trimming machine, a cutter head or wheel having its periphery reduced in diameter from one side toward the opposite side for a portion of the width of the cutter head or wheel to form a narrow bed 13, inclined slots or openings in the said wheel extended across the periphery of the same and interrupting the continuity of the said bed 13, transverse concavities a^5 made in the periphery of the wheel in both the bed 13 and the portion of reduced diameter and communicating with the said inclined slots, knives or cutters inserted in said inclined slots, a ring a^7 fastened to the side of the head or wheel of reduced diameter and provided with concavities a^{12} forming a continuation of the concavity a^5 but of smaller diameter, whereby one wall of the concavities a^{12} laps by and forms a side support for the knives or cutters, and means to adjustably secure the said knives or cutters to said head or wheel, substantially as described. 5th. In a rotary trimming machine, the combination of the following instrumentalities, viz:—A rotary shaft, a cutter head or wheel carried thereby to rotate therewith and provided with a periphery of different diameters to form a bed narrower than the width of the cutter head, knives or cutters carried by said head and provided with lips 2, 3, and the cutting edge 4, co-operating with said bed, an automatically operated axially slotted guard movable in opposite directions on the said shaft, and a stop to limit its movement toward the cutter head, substantially as described. 6th. In a rotary trimming machine, the combination of the following instrumentalities, viz:—A rotary shaft, a cutter head or wheel carried thereby to rotate therewith and provided with a periphery of different diameters to form a bed narrower than the width of the cutter head, knives or cutters carried by said head and co-operating with said bed, an automatically operated guard movable in opposite directions on the said shaft, and an adjustable stop carried by the guard and co-operating with the said head, substantially as and for the purpose specified. 7th. In a rotary trimming machine, the combination of the following instrumentalities, viz:—A rotary shaft, a cutter head or wheel carried thereby to rotate therewith and provided with a periphery of different diameters to form a bed narrower than the width of the cutter head, knives or cutters carried by said head and co-operating with said bed, and a sleeve provided with a guard and with an adjustable extension loose on said shaft to move axially thereon, and a spring encircling said sleeve and normally forcing the said sleeve toward the cutter head, substantially as described. 8th. In a rotary trimming machine, the combination of the following instrumentalities, viz:—A rotary shaft, a cutter head or wheel carried thereby to rotate therewith and provided with a periphery of different diameters to form a bed narrower than the width of the cutter head, cutters or knives carried by said head and co-operating with said bed, and a sleeve provided with a guard and with an adjustable extension loose on said shaft to move axially thereon, and a spring encircling said sleeve and normally forcing the said sleeve toward the cutter head, substantially as described. 9th. In a rotary trimming machine, the combination of the following instrumentalities, viz:—A rotary shaft, a cutter head carried thereby and provided with knives or cutters, and a sleeve loosely mounted on the said shaft to move axially thereon and provided with a guard for the said knives, a second sleeve loosely mounted on the said shaft and adjustably connected to the guard carrying sleeve to form an adjustable extension thereof, a spring to move the said sleeves in one direction, and stops to limit the simultaneous movement of the said sleeves in opposite directions, substantially as described. 10th. In a rotary trimming machine, the combination of the following instrumentalities, viz:—A rotary shaft, a cutter head or wheel carried thereby to rotate therewith and provided with a periphery of different diameters comprising the reduced portion 14, the raised bed 13 and the reduced portion or ledge 15 on the opposite side of the bed 13 from the reduced portion 14, cutters or knives carried by the said head and provided with lips 2, 3, and an intermediate cutting edge 4, a guard fitted over the reduced portion 14 and provided with slots for the reception of the lips 3, and a shield secured to the shaft and provided with the flange b^{20} fitted over the annular ledge 15, substantially as described. 11th. In a rotary trimming machine, the combination of the following instrumentalities, viz:—A rotary shaft, a cutter head carried thereby to rotate therewith and provided with a periphery of different diameters to form a smooth reduced portion 14, and a raised bed 13, knives or cutters carried by said head and provided with the cutting lips 2, 3, and the intermediate cutting edge 4, co-operating with the raised bed 13, and a sleeve loosely mounted on the said shaft and provided with a guard embracing the reduced portion 14 and provided with slots for the reception of the lips 3, and a spring to act on said sleeve, substantially as described. 12th. In a rotary trimming machine, the combination of the following instrumentalities, viz:—A rotary shaft, a cutter head carried thereby and provided with knives or cutters, and a sleeve loosely mounted on the said shaft to move axially thereon and provided with a guard for the said knives, a second sleeve loosely mounted on the said shaft and adjustably connected to the guard carrying sleeve to form an adjustable extension thereof, and a spring to move the said sleeves in one direction, substantially as described.

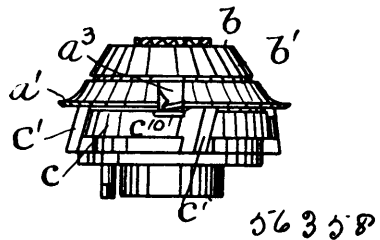
No. 56,359. Rand Guard and Knife.*(Garde bordure et couteau.)*

Ambrose Stevens Vose, Brookline, Mass., U.S.A., 21st June, 1897; 6 years. (Filed 25th May, 1897.)

Claim.—1st. The combination with a rand-guard or shield, of a knife or blade carried thereby or revolve therewith, means to adjust the said knife on its guard, and means to secure the said knife in its adjusted position, substantially as described. 2nd. The combination with a rand-guard or shield provided with a slot or opening in its rim portion, and with a channel in its body portion communicating with said slot or opening, of a rand-knife consisting of a blade and a shank, the said blade being extended through the said slot or opening and the said shank fitting the said channel, means to act on the said shank to adjust the said blade, and means to secure the knife in its adjusted position, substantially as described. 3rd. The combination with a guard or shield consisting of a frustum-shaped body portion provided with a slot or opening in its rim portion and with a channel in its outer side, of a knife consisting of a shank fitted into the said channel, and a blade extended at an angle to said shank to extend into the said slot or opening, a clamping device to secure the said shank to the guard, and an adjusting device for the knife carried by the clamping device, substantially as described. 4th. The combination with a rand-guard or shield, of a rand knife carried thereby to revolve therewith, a clamping device to secure the said knife to the guard, and an adjusting device carried by the clamping device to co-operate with the said knife, substantially as described. 5th. The combination with a rotary cutter provided with an annular body or wheel provided with a notch or recess c^{10} , on one side, of a rand-guard co-operating with said body and provided with a slot or opening in its face adjacent to the rotary cutter to register with the notch or recess c^{10} , a rand-knife provided with a blade extended through said slot and having its cutting edge separated from one side of the slot to leave a clearance-space for the passage of the cut material to the rear side of the blade, the said recess forming a clearance-space for the passage on the front side of the blade of the cut material, substantially as described. 6th. The combination with a frustum-shaped rand-guard provided with a slot or opening in its rim portion and with a channel on its outer side communicating with said slot, a rand-knife consisting of a shank to enter the said channel and a blade at an angle to the shank to enter the said slot or opening, a hollow clamping device fitted over the rand-guard to engage the shank of the said knife, an adjusting device for the knife, and means to secure the clamping device to the guard, substantially as described. 7th. The combination with a rand-guard or shield consisting of an annular body portion, a rand-knife secured to the said body portion and movable axially thereon, a clamping device to secure the said knife in its adjusted position, and means to adjust said knife in its guard, substantially as described.

No. 56,359. Door Hanger. (Ferrure de porte.)

Henry L. Ferris, Harvard, Illinois, U.S.A., 21st June, 1897; 6 years. (Filed 25th May, 1897.)

Claim.—1st. A door hanger comprising a bearing wheel and frame adapted to be secured to the door, projecting above the latter and provided with a suitable housing for said wheel, of a strap secured at its lower end to the frame, a spreader interposed between the upper portion of the door and the central portion of said strap and means for securing the strap at said central portion, the upper end of the strap extending to or near the housing, and a tie-bolt for securing the sides of the housing against lateral spread and at the same time locking the wheel in position and securing the upper end of said tie-bolt, substantially as and for the purpose specified. 2nd. A door hanger comprising a frame provided at its upper end with a housing and adapted to be secured at its lower end to a door, an aperture in each side of said housing, flanged thimbles, the reduced portions of which fit in said apertures, apertures extending through each of said thimbles constituting journal bearings, a wheel the hubs of which are suitably journaled within said thimbles, a centrally enlarged opening extending through both hubs, a tie-bolt extending through the thimbles and through said central opening without being in contact with the latter, and means for securing said tie-bolt ends upon the outside of said thimbles, substantially as described. 3rd. A door hanger comprising a frame adapted to be secured at one end to a door and having at its opposite end a housing, apertures through the sides of said housing,

flanged journal bearings in said apertures, anti-friction rollers in said bearings, a supporting wheel mounted in the said housing between

and between which and either of such other elements there exists independently the relation of armature and field, means for estab-

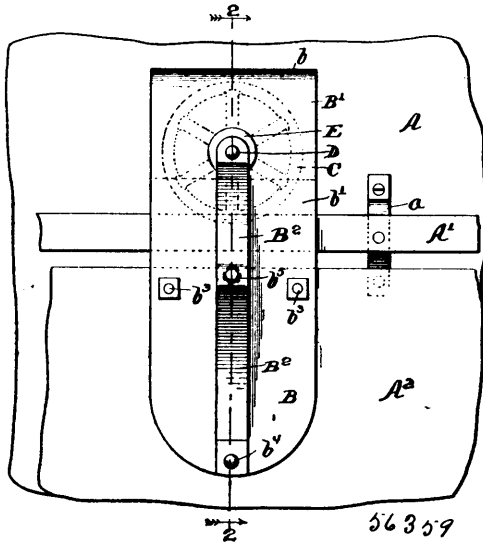

the sides thereof, provided with bearing surfaces constituting journals supported directly and only upon said anti-friction rollers, and a single tie-bolt passing centrally through said wheel and through the housing for securing the same together, substantially as described.

No. 56,360. Grinding Mill. (Moulin à blé.)

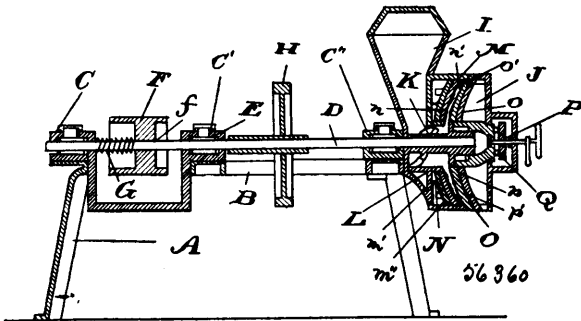

The Gould, Shapley & Muir Co., Limited, Brantford, Ontario, Canada, assignees of John Muir, same place, 21st June, 1897; 6 years. (Filed 8th February, 1896.)

Claim.—1st. In a grinding mill, the combination of two grinding plates M, O, one stationary and having U-shaped cushion springs N, and the other rotated by a shaft and adjustable to and from the other by a feed screw P, as set forth. 2nd. In a grinding mill, the combination with the driving shaft, of a series of journal boxes or bearings C, C¹, C², having rollers therein, a grinding plate O, on said shaft, a stationary grinding plate M, having springs N, and a feed regulator P, provided with ball bearings Q, as and for the purpose set forth. 3rd. A grinding plate for grinding mills, having a dress comprising three concentric circles of radial teeth or cutting edges, the inner coarse, the middle circle finer, both raking in one direction, and the teeth of the outer circle raking in the opposite direction to the other teeth, as set forth. 4th. A grinding plate for grinding mills, having a dress comprising radial teeth or cutting edges 6, uniform throughout the plate and provided with mutilations or indentations 9, dispersed or in diagonally broken rows or lines, as set forth.

No. 56,361. Electric Machine. (Machine électrique.)

William Henry Cooley, Brockport, New York, U.S.A., 21st June, 1897; 6 years. (Filed 3rd September, 1896.)

Claim.—1st. In an alternating current machine, in combination with the armature and field thereof, rectifying devices carried by such armature or field and co-operating with others carried by a third element, and means for establishing and maintaining a relative synchronous rotation between such third element and the armature or field carrying such rectifying devices. 2nd. Three elements, one of which is located in operative relation to two others

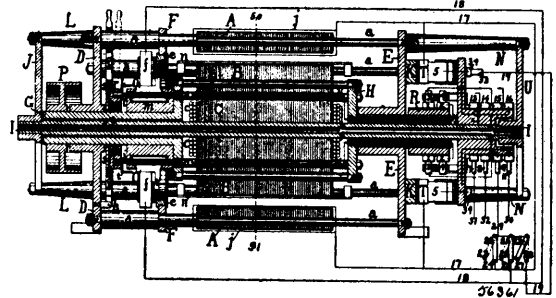

lishing and maintaining between two of such elements, located in operative relation to each other, a relative synchronous rotation by means of alternating currents supplied to windings on one or both of them, rectifying devices carried by said two of such elements co-operating together, and means for supplying alternating currents to such rectifying devices. 3rd. In combination with the armature and field of an alternating current machine and a commutator connected with the windings on one of such elements, a third element, means for establishing and maintaining a relative synchronous rotation between such third element and such armature or field, current rectifying devices carried by such third element and by such armature or field, and brushes carried by such third element, supplying direct currents from such rectifying devices and bearing upon such commutator. 4th. In combination with the armature and field of an alternating current machine, a third element located in operative relation to such armature or field, means for establishing and maintaining a relative synchronous rotation between such third element and such armature or such field, current rectifying devices carried by such third element and by such armature or field co-operating together, and means for supplying to windings, on both such armature and such field, currents rectified by such rectifying devices. 5th. Two elements bearing the relation to each other of armature and field, one or both of them revoluble, means for supplying to windings on one or both of such elements alternating currents and thereby establishing and maintaining a relative synchronous rotation between them, current rectifying devices carried by such elements and co-operating together, and means for supplying the currents rectified thereby to windings on that one of such elements carrying such rectifying devices and also to windings on a third element, located in operative relation thereto, in a manner to produce an angular displacement between the poles in such last two elements. 6th. Three elements, one of which is located in operative relation to two others and between which and either of such other elements there exists independently the relation of armature and field, means for establishing and maintaining between two of such elements, located in operative relation to each other, a relative synchronous rotation by means of alternating currents supplied to windings on one or both of them, rectifying devices carried by said two of such elements co-operating together, and means for supplying direct currents from such rectifying devices to windings on that one of such three elements located in operative relation thereto. 7th. In combination with the armature and field of an alternating current machine, a third element or member, current rectifying devices carried by such armature or field and co-operating with others carried by such third element or member, and means for producing and maintaining a constant relative synchronous rotation between such third element or member and such armature or field carrying such rectifying devices, and means for supplying the currents rectified thereby to windings on such armature and on such field, and for maintaining an angular displacement between the poles produced thereby in such armature and in such field. 8th. Three elements, one of which is located in operative relation to two others, and between which and either of such other elements there exists independently the relation of armature and field, means for establishing and maintaining between two of such elements, located in operative relation to each other, a relative synchronous rotation by means of alternating currents supplied to windings on one or both of them, rectifying devices carried by said two of such elements co-operating together, and means for supplying direct currents from such rectifying devices to windings on that one of such three elements located in operative relation to the other two. 9th. In combination with the armature and field of an alternating current machine, a third element, means for establishing and maintaining a relative synchronous rotation between such third element and such armature or such field, current rectifying devices carried by such third element and such armature or field co-operating together, and means for supplying to windings on the one of such armature or field, carrying such rectifying devices, direct currents from such rectifying devices. 10th. In an alternating current machine, in combination with the two elements thereof, constituting the armature and field, rectifying devices carried in part by one of such elements and co-operating with others carried by a third element, means for establishing and maintaining a relative synch-

ronous rotation between said one of such first named elements and such third element, and means for supplying rectified currents from such rectifying devices to windings on the other one of such first named elements. 11th. In an alternating current machine, in combination with the two elements thereof, constituting the armature and field, a commutator connected to the windings on one of such elements, rectifying devices carried by the other one of such elements co-operating with others carried by a third element, such third element also carrying brushes bearing on such commutator and supplying rectified currents from such rectifying devices, and means for establishing and maintaining a relative synchronous rotation between such third element and that one of such first named elements carrying such rectifying devices. 12th. Three elements, one of which is located in operative relation to two others, and between which and either of such other elements there exists independently the relation of armature and field, means for establishing and maintaining between two of such elements, located in operative relation to each other, a relative synchronous rotation by means of alternating currents supplied to windings on one or both of them, rectifying devices carried by said two of such elements co-operating together, and means for supplying direct currents from such rectifying devices to windings on the third one of such three elements. 13th. In an alternating current machine, in combination with the two elements thereof, constituting the armature and field, rectifying devices carried in part by one of such elements and co-operating with others carried by a third element, means for establishing and maintaining a relative synchronous rotation between said one of such first named elements and such third element, and means for supplying rectified currents from such rectifying devices to windings on the other one of such first named elements, producing poles therein bearing a constant angular relation to those in said one of such first named elements bearing the relation of armature or field thereto. 14th. Three elements, one of which is located in operative relation to the others, and between which and either of such other elements there exists independently the relation of armature and field, means for establishing and maintaining between two of such elements, located in operative relation to each other, a relative synchronous rotation by means of alternating currents supplied to windings on one or both of them rectifying devices carried by said two of such elements co-operating together, and means for supplying direct currents from such rectifying devices to windings on the third one of such three elements, producing poles therein bearing a constant angular relation to those in that one of such three elements in operative relation to the other two. 15th. In an alternating current machine, in combination with the two elements thereof, constituting an armature and field, means for producing rotatively progressing poles or series of poles in one of such elements, rectifying devices carried in part by said one of such elements, co-operating with others carried by a third element, means for establishing and maintaining a relative synchronous rotation between said one of such first named elements and such third element, and means for supplying rectified currents from such rectifying devices to windings on the other one of such first named elements and for producing poles therein bearing a constant angular relation to the rotatively progressing poles produced in the first named one of such two elements constituting the armature and field. 16th. In an alternating current machine, in combination with the two elements thereof, constituting the armature and field, a commutator connected to the windings on one of such elements, means for producing rotatively progressing poles or series of poles in the other one of such elements, rectifying devices carried by said other one of such elements co-operating with others carried by a third element, such third element also carrying brushes bearing on such commutator and supplying rectified currents from such rectifying devices, and means for establishing and maintaining a relative synchronous rotation between such third element and that one of such first named elements carrying such rectifying devices. 17th. Three elements, one of which is located in operative relation to two others and between which and either of such other elements there exists independently the relation of armature and field, means for producing in said one of such elements, located in operative relation to the other two, rotatively progressing poles or series of poles, means for establishing and maintaining between such element and one of the other two elements, located in operative relation thereto, a relative synchronous rotation, rectifying devices carried by such last two named elements, co-operating together, and means for supplying direct currents from such rectifying devices to windings on the third one of such three elements, and for producing poles therein bearing a constant angular relation to the rotatively progressing poles or series of poles produced in that one of such three elements located in operative relation to the other two. 18th. Two elements, bearing the relation to each other of armature and field, one or both of them removable, means for supplying to the windings on one or both of such elements, alternating currents and thereby establishing and maintaining a relative synchronous rotation between them, in combination with current-directing devices, carried by such elements and co-operating together, constituting means for producing a polar progression in conductors arranged on one of such elements, located in operative relation to a third element to which it bears the relation of armature or field. 19th. Two elements bearing the relation to each other of armature and field, one or both of them revolvable, means for supplying to windings on one or both of such elements alternating

currents, and thereby establishing and maintaining a relative synchronous rotation between, in combination with current-directing devices, carried by such elements and co-operating together, constituting means for producing a polar progression in conductors arranged on one of such elements, located in operative relation to a third element to which it bears the relation of armature or field, such third element wound with insulated wire. 20th. Two elements bearing the relation to each other of armature and field, one or both of them revolvable, means for supplying to windings on one or both of such elements alternating currents and thereby establishing and maintaining a relative synchronous rotation between them, in combination with current-directing devices, carried by such elements and co-operating together, constituting means for producing a polar progression in conductors arranged on one of such elements, located in operative relation to a third element to which it bears the relation of armature or field, such third element wound with insulated wire in a closed coil. 21st. In an alternating current machine, in combination with the two elements thereof, constituting the armature and field, current-directing devices carried in part by one of such elements and co-operating with others carried by a third element, means for establishing and maintaining a relative synchronous rotation between said one of such first named elements and such third element, means for supplying alternating currents to such directing devices, such current-directing devices constituting means for producing, in that one of such first named elements carrying them, a constant polar progression at all times during such synchronous rotation. 22nd. In alternating current machine, in combination with the two elements thereof, constituting the armature and field, current-directing devices carried in part by one of such elements and co-operating with others carried by a third element, means for establishing and maintaining a relative synchronous rotation between said one of such first named elements and such third element, the other one of such first named elements wound with insulated wire, means for supplying alternating currents to such current-directing devices, such current directing devices constituting means for producing, in that one of such first named elements carrying them, a constant polar progression at all times during such synchronous rotation. 23rd. In an alternating current machine, in combination with the two elements thereof, constituting the armature and field, current directing devices carried in part by one of such elements and co-operating with others carried by a third element, means for establishing and maintaining a relative synchronous rotation between said one of such first named elements and such third element, the other one of such first named elements wound with insulated wire in a closed coil, means for supplying alternating currents to such current directing devices, such current directing devices constituting means for producing, in that one of such first named elements carrying them, a constant polar progression at all times during such synchronous rotation. 24th. In an alternating current machine, an element wound with insulated wire connected with the sections of a commutator having brushes bearing thereon, another element located in operative relation to such first named elements, means, independent of relative rotation between such elements, for producing and maintaining a relative synchronous rotation between such commutator and such brushes, means for supplying alternating currents to such brushes, such insulated wire so connected to such commutator sections that such synchronous rotation between such commutator and such brushes shall produce a polar progression in the windings on such first element. 25th. In an alternating current machine, an element wound with insulated wire connected with the sections of a commutator having brushes bearing thereon, another element located in operative relation to such first named element, means, independent of relative rotation between such elements, for producing and maintaining a relative synchronous rotation between such commutator and such brushes, means for supplying alternating currents to such brushes, such insulated wire so connected to such commutator sections that such synchronous rotation between such commutator and such brushes shall produce a polar progression in the windings on such first element, such other element wound with insulated wire. 26th. In an alternating current machine, an element wound with insulated wire connected with the sections of a commutator having brushes bearing thereon, another element located in operative relation to such first named element, means, independent of relative rotation between such elements, for producing and maintaining a relative synchronous rotation between such commutator and such brushes, means for supplying alternate currents to such brushes, such insulated wire so connected to such commutator sections that such synchronous rotation between such commutator and such brushes shall produce a polar progression in the windings on such first element, such other element wound with insulated wire in a closed coil. 27th. In an alternating current machine, two magnetically distinct windings, having a common mechanical support, a separate element located in operative relation to each of such magnetically distinct windings, means for producing and maintaining a relative synchronous rotation between one of such separate elements and the windings located in operative relation thereto, in combination with current directing devices controlled by such synchronous rotation constituting means for producing a polar progression in the other winding. 28th. In an alternating current machine, two magnetically distinct windings, having a common mechanical support, a separate element located in operative relation to each of such mag-

netically distinct windings, means for producing and maintaining a relative synchronous rotation between one of such separate elements and the windings located in operative relation thereto, in combination with current directing devices controlled by such synchronous rotation, constituting means for producing a polar progression in the other winding, that element located in operative relation to such last-named winding wound with insulated wire. 29th. In an alternating current machine, two magnetically distinct windings, having a common mechanical support, a separate element located in operative relation to each of such magnetically distinct windings, means for producing and maintaining a relative synchronous rotation between one of such separate elements and the windings located in operative relation thereto, in combination with current directing devices controlled by such synchronous rotation, constituting means for producing a polar progression in the other winding, that element located in operative relation to such last-named winding wound with insulated wire in a closed coil. 30th. In an alternating current machine, two magnetically distinct windings, having a common mechanical support, a separate element located in operative relation to each of such magnetically distinct windings, means for producing and maintaining a relative synchronous rotation between one of such separate elements and the windings located in operative relation thereto, in combination with current directing devices controlled by such synchronous rotation, constituting means for producing a polar progression in the other winding, that element, located in operative relation to such last named winding, wound with insulated wire, current rectifying devices controlled by such synchronous rotation, and means for supplying the alternating currents rectified thereby to the windings on such last-named element, and producing therein magnetic poles maintaining a constant angular relation to those progressively set up in that winding located in operative relation thereto. 31st. In combination with the armature and field of an alternating current machine, rectifying devices co-operating together and carried by mechanism forming an organized part of such machine and controlled in its operation by alternating currents supplied to the machine, means for supplying alternating currents to such rectifying devices, means for supplying such alternating currents so rectified, by such rectifying devices, to such armature or to such field, such rectifying devices located in series with the windings on such armature or on such field, and constituting means for rectifying such alternating currents independent of the rate of relative rotation between such armature and field. 32nd. In an alternating current machine, in combination with the armature and field thereof, current directing devices for supplying such alternating currents to windings on one of such elements of armature or field, constituting means for producing, in said one of such elements, magnetic poles which shall remain constant in sign for all rates of relative rotation between such armature and such field. 33rd. In an alternating current machine, in combination with the armature and field thereof, current directing devices for supplying such alternating currents to windings on such armature and on such field, constituting means for producing in such armature and in such field magnetic poles which shall remain constant in sign for all rates of relative rotation between such armature and such field. 34th. In an alternating current machine, in combination with the two elements constituting the armature and field thereof, current directing devices for supplying such alternating currents to the windings on one of such elements of armature or field, constituting means for producing, in said one of such elements, magnetic poles or series of poles, rotatively progressing therein at a fixed and uniform rate, at all times and for all speeds of relative mechanical rotation between such elements. 35th. In an alternating current machine, in combination with the two elements constituting the armature and field thereof, current directing devices for supplying such alternating currents to the windings on such armature or on such field, constituting means for producing in one of such elements magnetic poles or series of poles, maintaining, at all times and for all speeds of relative mechanical rotation between such armature and field, such a relation to any given point in the periphery of such other element, as shall constitute a relative synchronous mechanical rotation between such magnetic poles or series of poles and such given point. 36th. In an alternating current machine, in combination with the two elements constituting the armature and field thereof, current directing devices for supplying such alternating currents to the windings on such armature and on such field, constituting means for producing in one of such elements, magnetic poles or series of poles, maintaining, at all times and for all speeds of relative mechanical rotation between such armature and field, such a rate of progression, relative to any given point in said one of such elements, as shall constitute the difference between the actual rate and a synchronous rate of mechanical rotation of such other element. 37th. In a machine for use with alternating currents in combination with the armature and field thereof, current directing devices for supplying such alternating currents to windings on such armature and on such field, constituting means for producing magnetic poles or series of poles in such armature and in such field, such magnetic poles or series of poles, in either one or both of such elements, rotatively progressing at such a rate that for all relative rates of mechanical rotation between such elements, the united rates of rotative progression of the magnetic poles or series of poles in each of such elements, relative to a fixed point outside of such elements, shall be equal to a synchronous rate of ad-

vance or progression. 38th. Two magnetically separate and distinct series of field magnets, mechanically united, and each energized by alternating currents of different phase, two magnetically separate and distinct armatures located in operative relation to such magnets, mechanically united, and wound with insulated wire, and means for supplying to the windings on each of such armatures rectified currents from both of such alternating currents of different phase. 39th. Two magnetically separate and distinct series of field magnets, mechanically united, and each energized by alternating currents of different phase, two magnetically separate and distinct armatures, located in operative relation to such magnets, mechanically united, and wound with insulated wire, and means for supplying to the windings on each of such armatures rectified currents from both of such alternating currents of different phase, and for maintaining between the poles produced thereby and those produced in such fields by such alternating currents a constant angular relation. 40th. Two magnetically separate and distinct series of field magnets, mechanically united, and each energized by alternating currents of different phase, two magnetically separate and distinct armatures, located in operative relation to such magnets, mechanically united, and wound with insulated wire, means for supplying to the windings on each of such armatures rectified currents from both of such alternating currents of different phase, means for rectifying such alternating currents consisting in devices carried by such field magnets and still another armature, or other armatures located in operative relation thereto, and means for establishing and maintaining between such field magnets and such last named armature or armatures, located in operative relation thereto, a relative synchronous rotation. 41st. Two magnetically separate and distinct series of field magnets, mechanically united, and each energized by alternating currents of different phase, two magnetically separate and distinct armatures, located in operative relation to such magnets, mechanically united, and wound with insulated wire, means for supplying to the windings on each of such armatures rectified currents from both of such alternating currents of different phase, means for rectifying such alternating currents consisting in devices, carried by such field magnets and a third element, co-operating together, and means for establishing and maintaining between such field magnets and such third element, a relative synchronous rotation. 42nd. In combination with one element consisting in two or more series of magnets, each series energized by alternating currents of different phase, a second element and means for establishing and maintaining a relative synchronous rotation between such first and second elements, rectifying devices carried by such elements co-operating together, brushes carried by such second element supplying direct currents, from such rectifying devices, to the windings on a third element through the sections of a commutator, connected thereto and upon which such brushes are arranged to bear. 43rd. In combination with one element consisting in two or more series of magnets, each series energized by alternating currents of different phase, rectifying devices for each of such alternating currents of different phase, carried in part by such element and by a second element co-operating together, means for establishing and maintaining a relative synchronous rotation between such first and second elements, and means for supplying such alternating currents to such rectifying devices, brushes carried by such second element and supplying direct currents from such rectifying devices to the windings on a third element, located in operative relation to such first named element, through the sections of a commutator connected therewith and upon which such brushes are arranged to bear. 44th. In combination with one element consisting in two or more series of magnets, each series energized by alternating currents of different phase, another element located in operative relation thereto, rectifying devices carried in part by such first-named element and by a third element co-operating therewith, means for establishing and maintaining a relative synchronous rotation between such first named element and such third element, means for supplying direct currents from such rectifying devices to the windings on the second element, and for producing therein magnetic poles bearing a constant angular relation to those rotatively set up in such first named element, for all rates of relative rotation between such first and second elements. 45th. In combination with the armature of a multiphase alternating current machine, rectifying devices for each alternating current of different phase, co-operating together and carried by mechanism controlled in its operation by such alternating current of different phase, co-operating together and carried by mechanism controlled in its operation by such alternating currents of different phase supplied to such machine and forming an organized part of such machine, means for supplying such alternating currents of different phase to such rectifying devices means for supplying to the armature or armatures of such machine such alternating currents of different phase rectified by such rectifying devices, located in series with such armature or armatures. 46th. In an alternating current machine, an element consisting in a field having rotatively progressing magnetic poles produced therein, an armature located in operative relation thereto and wound with insulated wire, rectifying devices carried by such first named element and co-operating with others carried by a third element, means for maintaining a relative synchronous rotation between such first and such third named elements, and means for supplying such alternating currents to such rectifying devices and for supplying such alternating currents, rectified thereby, to the windings on such armature and thereby

producing therein magnetic poles bearing a fixed angular relation to such rotatively progressing magnetic poles, for any and all rates of relative rotation between such armature and field. 47th. In an alternating current machine, an element consisting in a field having rotatively progressing magnetic poles, advancing at a synchronous rate, produced therein, an armature located in operative relation thereto and wound with insulated wire, rectifying devices carried by such first named element and co-operating with others carried by a third element, means for maintaining a relative synchronous rotation between such first and such third named elements, and means for supplying such alternating currents to such rectifying devices and for supplying such alternating currents, rectified thereby, to the windings on such armature and thereby producing therein magnetic poles rotatively progressing in such armature at a rate which shall constitute the difference between the actual relative rotation between such armature and field and a synchronous rate of relative rotation between such armature and field. 48th. In combination with the armature and field of an electric machine and means for producing in one of such elements rotatively progressing magnetic poles, advancing at a synchronous rate, current directing devices constituting means for supplying alternating currents to the windings on the other one of such elements and thereby producing therein magnetic poles that, for any and all rates of relative mechanical rotation between such elements, shall remain constant in sign and shall rotatively progress in such other one of such elements at a rate which shall constitute the difference between the actual relative rotation between such elements and a synchronous rate of relative rotation between such elements. 49th. In combination with the armature and field of an electric machine and means for producing in one of such elements rotatively progressing magnetic poles, current directing devices, constituting means for supplying alternating currents to the windings on the other one of such elements and thereby producing therein magnetic poles that shall, for any and all rates of relative rotation between such elements, remain constant in sign and bear a fixed angular relation to such rotatively progressing magnetic poles. 50th. In an electric machine, a compound element, one of the component parts of which is located in operative relation to a second element and constituting therewith the armature and field of a motor proper, the other component part of such compound element located in operative relation to a third element and constituting therewith the armature and field of a motor generator, electric conductors constituting a winding on one of such motor generator elements independent of any winding supplied with electric currents for producing magnetic poles in such motor generator element, means independent of relative rotation between such motor elements, for maintaining a relative rotation between such motor generator elements, such generative winding connected in series with the windings on one of such motor elements. 51st. In an electric machine, a compound element, one of the component parts of which is located in operative relation to a second element and constituting therewith the armature and field of a motor proper, the other component part of such compound element located in operative relation to a third element and constituting therewith the armature and field of a motor generator, electric conductors constituting a winding on one of such motor generator elements independent of any winding supplied with electric currents for producing magnetic poles in such motor generator element, means independent of relative rotation between such motor elements, for maintaining a relative rotation between such motor generator elements, and means for supplying the electric currents induced in such generative winding to windings on one of such motor elements and thereby producing therein magnetic poles bearing a constant angular relation to those in the other one of such motor elements. 52nd. In an electric machine, a compound element, one of the component parts of which is located in operative relation to a second element and constituting therewith the armature and field of a motor proper, the other component part of such compound element located in operative relation to a third element and constituting therewith the armature and field of a motor generator, electric conductors constituting a winding on one of such motor generator elements independent of any winding supplied with electric currents for producing magnetic poles in such motor generator element, means independent of relative rotation between such motor elements, for maintaining a relative rotation between such motor generator elements, and means for supplying the electric currents induced in such generative winding to windings on one of such motor elements and thereby producing in each of

such motor elements magnetic poles bearing a constant angular relation to those in the other. 54th. In an electric machine, a compound element, one of the component parts of which is located in operative relation to a second element and constituting therewith the armature and field of a motor proper, the other component part of such compound element located in operative relation to a third element and constituting therewith the armature and field of a motor generator, electric conductors constituting a winding on one of such motor generator elements independent of any winding supplied with electric currents for producing magnetic poles in such motor generator element, means independent of relative rotation between such motor elements for inducing electric currents in such generative winding, and means for supplying the electric currents induced in such generative winding to windings on one of such motor elements and thereby producing therein magnetic poles bearing a constant angular relation to those in the other one of such motor elements. 55th. In an electric machine, a compound element, one of the component parts of which is located in operative relation to a second element and constituting therewith the armature and field of a motor proper, the other component part of such compound element located in operative relation to a third element and constituting therewith the armature and field of a motor generator, electric conductors constituting a winding on one of such motor generator elements independent of any winding supplied with electric currents for producing magnetic poles in such motor generator element, means independent of relative rotation between such motor elements, for inducing electric currents in such generative winding, and means for supplying the electric currents induced in such generative winding to windings on each of such motor elements and thereby producing in each of such motor element magnetic poles bearing a constant, angular relation to those in the other. 56th. Three elements, two of them revoluble relatively to and independently of each other, two of such elements located in operative relation to each other and constituting an armature and field, a third element located in operative relation to a magnetic mass constituting or carried by one of such elements of armature and field, means, controlled by a relative rotation between such armature and field, for maintaining in such third element and in such magnetic mass magnetic poles maintaining to each other a practically uniform relation and rotatively progressing in either one or both of such third element and magnetic mass, independent of relative rotation between such third element and magnetic mass. 57th. Three elements, two of them revoluble relatively to and independently of each other, two of such elements located in operative relation to each other and constituting an armature and field, a third element located in operative relation to a magnetic mass constituting or carried by one of such elements of armature and field, means, controlled by the relative rotation between such armature and field, for maintaining in such third element and in such magnetic mass magnetic poles constant in sign and maintaining to each other practically uniform relation and rotatively progressing in either one or both of such third element and magnetic mass, independent of relative rotation between such third element and magnetic mass. 58th. Three elements, two of them revoluble relatively to and independently of each other, two of such elements located in operative relation to each other and constituting an armature and field, a third element located in operative relation to a magnetic mass constituting or carried by one of such elements of armature and field, a commutator connected to windings on one of such elements of armature and field, a commutator connected to the windings on such magnetic mass, a commutator connected to the windings on such third element, brushes carried by the other one of such elements of armature and field and bearing on such commutators and supplying electric currents to the windings connected thereto. 59th. The within described method of operating alternating current motors consisting in supplying the energy from alternating current mains or feeders, through devices controlled by a relative synchronous rotation between one of the elements of such motor and a third element, in such a way as to produce in the armature and field of such motor magnetic poles constant in sign and bearing a fixed angular relation to each other independent of relative rotation between the armature and field of such motor. 60th. The within described construction for an electric machine consisting in the operative elements thereof, constructed, arranged and operating in the manner and for the purpose substantially as shown and described.

No. 56,362. Heater. (Chauffeur.)

Friedrich W. G. Boettcher, Duluth, Minnesota, U.S.A., 21st June, 1897; 6 years. (Filed 3rd March, 1896.)

Claim.—1st. The combination with two or more groups of compartments situated one group above another, of a heater extending from one group to the other, and having substantially uniform dimension from its top to its bottom, means for retarding the flow of products through the heater, and means for carrying away the products of combustion, substantially as described. 2nd. A combined heater and cooking-stove, comprising a fire-box, an oven adjutably mounted above the same and closing the cross section of

the heater but provided with suitable recesses for the upward passage of heat above the same, and a damper for closing the rear

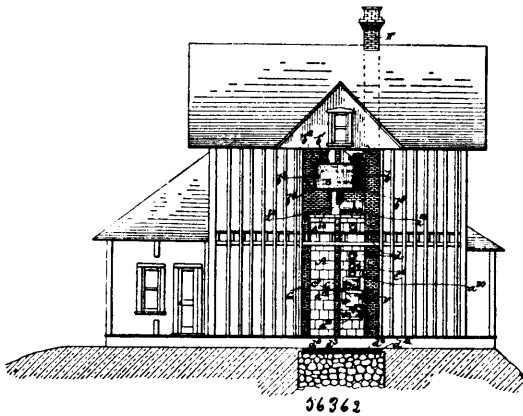

recess so as to cut off the heat from that part of the oven, substantially as described.

No. 56,363. Nut Lock. (*Arrête-écrou.*)

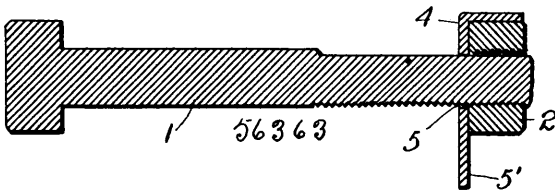

Christopher Columbus Howard and Lizzie Saunders, both of Lebanon, Missouri, U.S.A., 21st June, 1897; 6 years. (Filed 2nd November, 1896.)

Claim.—The combination with a bolt consisting of a screw-threaded shank having a head at one end, the other end portion of said shank being partially cut away to form a flat and smooth face, of a screw-threaded nut, and a washer having an aperture consisting of a segment of a circle and a flat side to conform to the contour of the cut-away portion of the shank, and having also wings or fingers to be bent against the lateral faces of the nut, substantially as shown and specified.

No. 56,364. Dyeing Apparatus. (*Appareil à teindre.*)

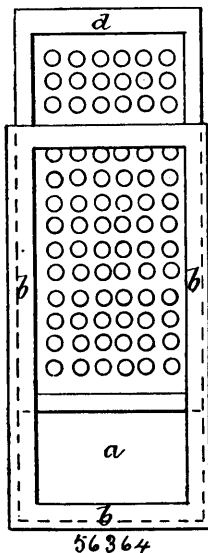

Charles Edward Middleton, Francis Phillips Middleton and Arthur Thomas Middleton, all of Aclington, Lancaster, England. 21st June, 1897; 6 years. (Filed 8th August, 1896.)

Claim.—1st. The improved cop case, substantially as described and shown, for the purpose set forth. 2nd. In a dyeing vat, the metal flanges or surfaces *i* and *l*, the improved metal lid *k*, and guide or slide *h*, either with or without spring *hr*, substantially as described and shown, for the purpose set forth.

No. 56,365. Insulator. (*Isolateur.*)

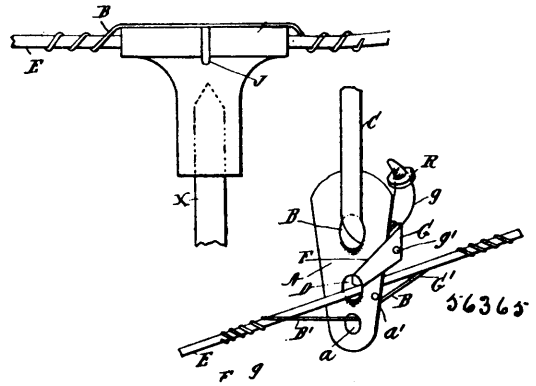

Benjamin Du Bois Smock, Wickatunk, New Jersey, U.S.A., 21st June, 1897; 6 years. (Filed 13th July, 1896.)

Claim.—1st. An insulator for electric wires, consisting of a body portion provided with an opening to receive a wire, and a ribbed wedge adapted to be inserted to hold the wire therein, substantially as set forth. 2nd. An insulator for electric wires, consisting of a body portion provided with an opening to receive a wire, and a ribbed wedge adapted to be inserted to hold the wire therein, said insulator being also provided with an opening which is adapted to receive a hanger hook by which it is suspended, substantially as shown and described. 3rd. An insulator for electric wires, consisting of a body portion provided with an opening adapted to receive a wire, and a ribbed wedge adapted to be inserted to hold the wire therein, said insulator being also provided with an opening which is adapted to receive a hanger hook by which it is suspended, and said hanger hook being provided with a screw button which is detachably connected therewith, substantially as shown and described. 4th. An insulator constructed herein described, and provided with means for connecting a wire therewith, said insulator being provided with an opening which is adapted to receive a hanger hook, and a hanger hook which is adapted to be passed through said opening, and provided with a detachable button, substantially as shown and described. 5th. An insulator consisting of a body portion provided with an opening having an inclined outlet and grooves, and a removable wedge having ribs fitted to said grooves, substantially as shown and described.

No. 56,366. Process and Apparatus of Making Dough. (*Procédé et appareil pour faire de la pâte.*)

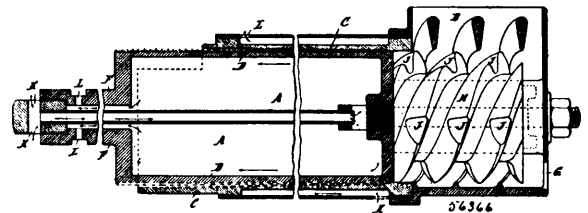

Auguste Desgoffe, Paris, France, and Octave Avedyk, Brussels, Belgium, 21st June, 1897; 6 years. (Filed 14th November, 1896.)

Claim.—1st. A process for the transformation of whole grain into bakers' dough in a single operation, consisting in crushing the previously soaked grain between the spirals of a series of male and female helices having their spirals arranged in an opposite direction one to the other and in forcing the dough thus obtained to pass without interruption between the spirals of a kneading helix fixed on the same motor shaft in order to be there worked with or without the free access of air into the dough, substantially as hereinbefore set forth. 2nd. An apparatus for carrying out the herein described process, characterized by several series of male and female helices converging from the feed end to the discharged end, and all preferably pitched to 17° 40' to a perpendicular from the axis, some of which helices serve at the commencement to cause the grain to advance, and others to decorticate it, until both together, because of their convergence unite or assist in reducing the grain and the bran to an impalpable paste which is then seized by a kneading and working device fixed on the same shaft as the male helices of the crushing apparatus, substantially as hereinbefore described and shown in the accompanying drawings. 3rd. In an apparatus for the manufacture of bakers' dough from whole grain such as described, a kneading and working device composed essentially of a box open to the air and containing a helix and a counter helix, the helix being fixed on the same shaft as the mandrel of the crushing or grinding apparatus and having spirals deeper and spaced further apart than those of the crushing device, in order to contain a greater quantity

of dough, and having the helices notched or recessed to assist the kneading of the dough, substantially as here-in-before described and shown in the accompanying drawings.

No. 56,367. Ore Extracting Process.

(Appareil à extraire le minerai.)

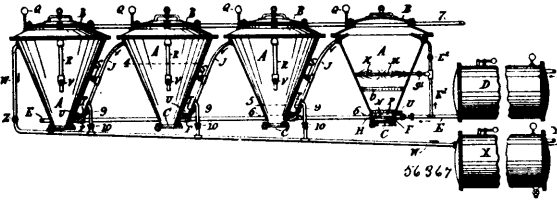

David White and Thomas Moore Simpson, both of Stawell, Victoria, Australia, 21st June, 1897; 6 years. (Filed 4th December, 1896.)

Claim.—1st. The process of extracting precious metals from slimes and other auriferous and argentiferous material, which consists in subjecting said material when contained in a closed vat together with a solvent solution of potassic cyanide, or other suitable material, to the action of gas introduced and put into circulation, substantially as and for the purposes set forth. 2nd. The process of extracting precious metals from slimes and other auriferous and argentiferous material which consists in charging said material into a series of vats containing a solvent solution of potassic cyanide, or other suitable material, closing said vats and causing gas and charged gas to be introduced and made to circulate repeatedly into, through and out of the various vats in said series successively by the agency of a compressor or pump outside said vats, and jets within the said vats, substantially as and for the purposes set forth. 3rd. The process of extracting precious metals from slimes and other auriferous and argentiferous material, which consists in charging said material into two or more vats containing a solvent solution of potassic cyanide or other suitable material, closing said vats, causing a flow of gas to pass through the contents of one vat and then causing the gas charged by passing through the first vat to pass through the contents of the second vat, substantially as and for the purpose specified. 4th. In an apparatus of the class described, a pear-shaped or conical vat, provided with a removable cover, a discharge door at its lower end, an inlet pipe provided with a series of jets within the vat, an outlet pipe near its upper end and one or more transverse gratings, substantially as and for the purpose specified. 5th. In apparatus of the class described, two or more pear-shaped or conical vats each provided with a removable cover, a discharge door at its lower end, an inlet pipe connected with a source of gas provided with a series of jets within the vat, an outlet pipe connecting the upper part of the first vat with the inlet pipe of the second and an outlet pipe from the upper part of the last vat connected with a receiver, substantially as and for the purpose specified. 6th. In an apparatus of the class described, two or more pear-shaped or conical vats each provided with a removable cover, a discharge door at its lower end, an inlet pipe connected with a source of gas provided with a series of jets within the vat, an outlet pipe connecting the upper part of the first vat with the inlet pipe of the second, an outlet pipe from the upper part of the last vat connected with a receiver, and connection between the outlet pipe from the first vat and the said receiver, suitable stopcocks being provided at all necessary points, substantially as and for the purpose specified. 7th. In apparatus of the class described, the combination of the vats A, the covers B, discharge doors C, the jets N and M, the pipes E and F, the pipes J, the pipes g, and the pipe W, a flow of gas in the pipe E, substantially as and for the purpose specified.

No. 56,368. Pessary. (Pessaire pour médecines.)

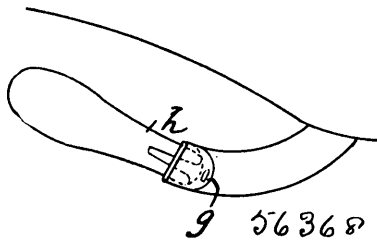

Franz Carl Heinrich Fickert and Phillip Grand Hammerschmitt, at Schwerin, Grand Dukedom Mecklenburg, (Germany, 21st June, 1897; 6 years. (Filed 19th January, 1897.)

Claim.—1st. A pessary comprising a cup having a spring rim, and a perforated chamber for containing medicine. 2nd. In a pessary, the combination of an outer cup, closed at bottom and having a spring-rim, of an inner perforated cup or diaphragm, substantially as and for the purpose set forth. 3rd. In a pessary, the

combination of an outer cup, having a spring rim, and an inner cup secured in said outer cup and having a hole for insertion of the medicine into the space between said cups, and perforations for diffusion of the medicine. 4th. In a pessary, the combination of outer and inner cups, the inner cup being perforated, substantially as and for the purpose set forth.

No. 56,369. Can Soldering Machine.

(Machine à souder les boîtes en fer blanc.)

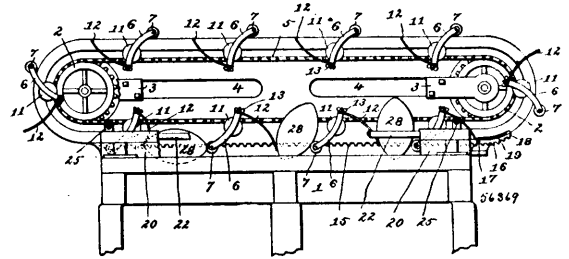

James L. Ashley and William E. McDermott, both of Brookfield, Washington, U.S.A., 23rd June, 1897; 6 years. (Filed 21st January, 1897.)

Claim.—1st. In a can soldering machine of the character described, a series of carriers, a friction roller journaled in the lower end of each of said carriers, a tension spring secured to the upper end of each of said carriers, the tension spring of one carrier acting in conjunction with the friction roller of the following carrier. 2nd. In a can soldering machine of the character described, a carrier, a rack, a second rack hinged to one end of said rack, a spring holding the hinged rack normally in line with the first named rack, and means connecting said rack with the carrier. 3rd. In a can soldering machine, a series of carriers, a friction roller journaled in the lower end of each of the carriers, a tension spring secured to the top of each of said carriers, a shaft extending laterally from said carriers, the tension spring of one carrier acting in conjunction with the friction roller of the following carrier, a pinion journaled on said shaft, a rack adapted to be engaged by said pinion, and an endless belt to which the carriers are secured, and means to operate the same. 4th. In a can soldering machine, an endless link belt, sprocket wheels adapted to engage said belt, a carrier having friction rollers at its lower end, and a tension spring secured to its upper end, a shaft extending laterally from said carrier, a pinion journaled on said shaft, means securing the carrier to the endless belt, a rack, a second rack hinged to the first named rack, a spring holding said second rack normally in line with the first named rack, a lower guide, a solder bath, and a front guide consisting of a rail, rods secured to said rail and loosely mounted in suitable standards, a coiled spring and an adjustable collar on said rods, all combined and operating as described.

No. 56,370. Manufacture of Aluminium Alloy.

(Fabrication d'alliage d'alumine.)

William Pearson, Birmingham, England, 23rd June, 1897; 6 years. (Filed 2nd February, 1897.)

Claim.—The method of making alloys of aluminium and cobalt, which consists in melting aluminium in a nickel crucible adding mercuric chloride as a flux to clear the same from dross, drawing the aluminium from the bottom of the crucible or melting vessel and running it into the melted cobalt.

No. 56,371. Gas Separator. (Séparateur à gaz.)

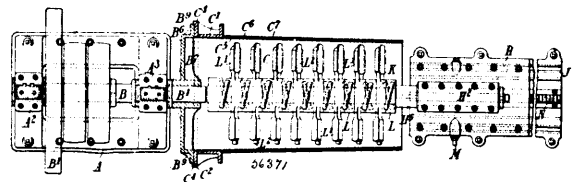

William Adolph Komeman, London, England, 23rd June, 1897; 6 years. (Filed 4th February, 1897.)

Claim.—1st. In separating apparatus, the combination of a strainer C, with helical discharge apparatus comprising shaft K, radial arms L¹ suitably secured thereto by means of bosses L, and carrying radially adjustable scrapers L², arranged to be capable of rotary motion and disposed in a helix in planes oblique to the axis of the strainer for the purpose specified. 2nd. In separating apparatus, the combination of a rotating strainer C, with stationary helical discharge apparatus, comprising overhanging shaft K, radial arms L¹, suitably secured thereto by means of bosses L, and carrying radially adjustable scrapers L², disposed in a helix in planes oblique to the axis of the strainer, for the purpose described. 3rd.

In separating apparatus, the combination of a strainer C, rotating upon its axis, with an independent or self-contained extracting device insertable in such strainer but not connected therewith, and comprising suitably supported radial arms L¹, and radially adjustable scrapers L², disposed in a helix of fine pitch or in planes oblique to the axis of the strainer, substantially as described. 4th. In separating apparatus, a discharge apparatus adapted to extend into a strainer C, from an independent support which is readily movable in the direction of the axis of the strainer, for the purpose specified. 5th. In a centrifugal separator, a strainer comprising two concentric perforated shells C⁵, C⁷, with a layer of felt, textile or other porous material C⁶, between them for the purpose specified. 6th. In a centrifugal separator, the modified construction of cage wherein the head C⁶ and shell C⁷ are integral with each other and receive internally a shell C⁵ and layer C⁶, substantially as described. 7th. In a centrifugal separator, stationary discharge apparatus comprising an adjustable head stock H, a fixed or rotatable shaft K, and blades or vanes fixed obliquely or helically thereon, for the purpose specified. 8th. In a centrifugal separator, the combination with a head B⁶, of a ring C¹ encircling one end of a taper perforated shell C⁵, which is fixed to it, a taper perforated shell C⁷, and means to draw the outer shell C⁷, endwise towards the inner one C⁵, substantially as and for the purpose specified. 9th. In a centrifugal separator, a strainer C, rotatable about a horizontal or approximately horizontal axis, and provided with an independent extraction device comprising suitably supported radial arms L¹, and radially adjustable scrapers L², disposed in a helix of fine pitch or in planes oblique to the axis of the strainer, for the purpose specified. 10th. In a separating apparatus of the kind described, the combination with a cage rotatable about a horizontal axis of a casing F, a trough F⁰, and a conveyor C¹, with or without the flange C⁹ or C¹⁰, for the purpose specified.

No. 56,372. Grain Weighing or Measuring Device.

(Appareil à mesurer et peser le grain.)

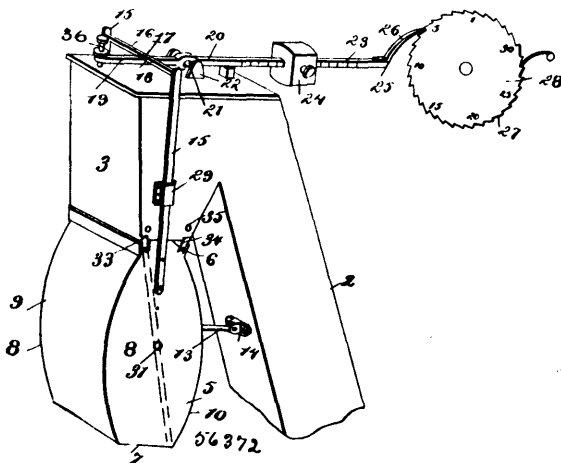

Harry Wilson Mosher, Geneva, Nebraska, U.S.A., 23rd June, 1897; 6 years. (Filed 9th March, 1897.)

Claim.—1st. A grain weighing machine, comprising a hopper provided with a centrally pivoted oscillating valve and suspended to one end of a scale beam, adapted to oscillate vertically, the upper end of said valve alternately engaging the rigid locking recesses located in line with and above the mouth of said hopper, substantially as and for the purpose set forth. 2nd. The rigid support 3, upon which is mounted an adjustable scale beam from which is suspended a hopper provided with a centrally pivoted oscillating valve normally locked in position and adapted to be released by the downward movement of the scale beam and hopper, substantially as and for the purpose set forth. 3rd. The elevator chute, provided with a discharge opening and side plates having locking recesses, and having a scale beam mounted thereon, in combination with a vertically reciprocating hopper suspended from said scale beam, and provided with a centrally pivoted valve, the upper end of which is adapted to alternately engage the locking recesses on the side plates of the chute, substantially as and for the purpose set forth. 4th. In a grain weighing machine, comprising an adjustable scale beam adapted to operate a grain counter, and provided with a suspended hopper open at the top and bottom, and provided with a centrally pivoted valve, the upper end of which extends beyond the mouth of the hopper and is adapted to be engaged and locked in position by a recess in a plate rigidly located above the mouth of said hopper, substantially as and for the purpose set forth. 5th. A grain weighing machine, comprising a stationary support upon which is mounted a scale beam adapted to automatically register its movement on a counter, a vertically reciprocating hopper suspended from said beam and provided with an internally pivoted oscillating valve, dividing said hopper into two equal compartments, which are alternately opened and closed by the automatic action of said valve, the upper end of which is controlled by engagement with a

recess in a rigid plate secured to the stationary support, substantially as and for the purpose set forth. 6th. The elevator chute 2, having the discharge opening 3, the sides of which are provided with the guide brackets 29-29 and the recesses 33 34, the scale beam 20 fulcrumed in a stationary bracket 22 rigidly secured to the top of the chute, and provided with the adjustable weight 24 and having the central V-shaped bearing 18, in combination with the hopper 5, the oscillating valve 30, centrally pivoted in said hopper, the side bars 15-15 rigidly secured at their lower ends to the sides of said hopper and extending upwardly through said guide brackets 29-29, and the cross bar 16 connecting the upper ends of said side bars 15-15, and provided with a central knife edge bearing 17, resting upon the bearing 18 in the scale beam 20, substantially as and for the purpose set forth.

No. 56,373. Stove and Range. (Poêle.)

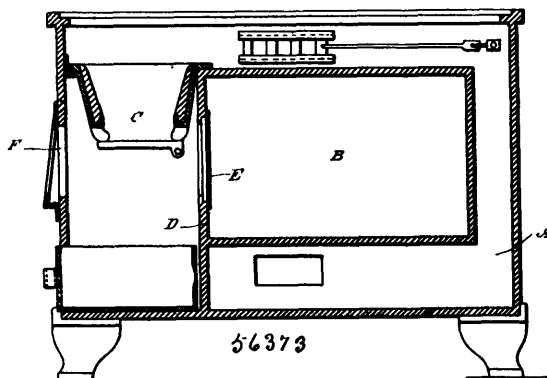

Joseph Wilfred Chapleau, Montreal, Quebec, Canada, 23rd June, 1897; 6 years. (Filed 18th March, 1897.)

Claim.—1st. In a stove or range, the providing of suitable lights permitting the inspection of the interior of the oven, substantially as described and for the purposes set forth. 2nd. In a stove or range the providing of suitable lights to view the interior of the oven lighted up by the glow from the fire in the fire-place, substantially as described and for the purposes set forth.

No. 56,374. Egg Tester.

(Appareil à faire l'épreuve des œufs.)

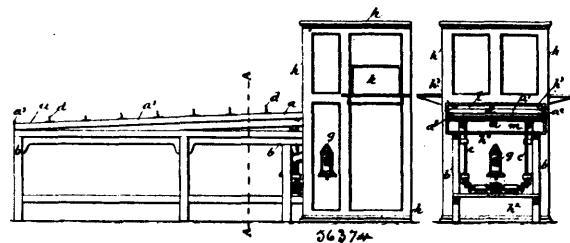

James Lyons, Alfred Lyons and George Lyons, all of Manchester, England, 23rd June, 1897; 6 years. (Filed 22nd March, 1897.)

Claim.—1st. In an apparatus for sorting round or partially round objects, a plain or table a furnished with standards or bars d which impede the rolling progress of the said objects according to their sizes, all substantially as and for the purpose set forth. 2nd. In an apparatus specified, for the purpose of testing eggs, a glass g the underside of which table is exposed to the rays of a light or lights or reflector, all substantially as set forth. 3rd. In combination with the testing device specified, the frame f adapted to slide upon the plain or table a, all substantially as and for the purpose set forth.

No. 56,375. Machine for Pressing Hay.

(Presse à foin.)

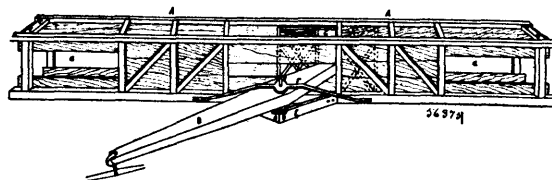

John Fretts Madden, London, Ontario, Canada, 23rd June, 1897; 6 years. (Filed 22nd March, 1897.)

Claim.—In a hay press, of the kind described, lever B fulcrumed at D in braces E and F attached to the main body of the press, and plunger C, all formed, combined and operated substantially as and for the purpose hereinbefore set forth.

No. 56,376. Flower Holder. (Porte-fleur.)

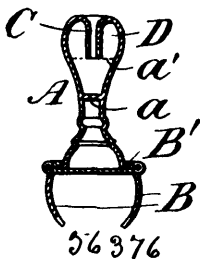

Adoniram Bird Cough, Tremont, Maine, U.S.A., 23rd June, 1897; 6 years. (Filed 23rd March, 1897.)

Claim.—1st. The combination with a flower-holder having a closed bottom, and a bulged top with a depressed opening terminating in an inwardly-extending tubular neck, of a socket in which the bottom of said holder is held, and spring-clamps pivotally connected with said socket, substantially as shown and described. 2nd. A flower-holder having a closed bottom and a bulged top with a depressed opening terminating in an inwardly-extending tubular neck, a socket in which the bottom of said holder is held, and spring-clamps pivotally connected with said socket, the said socket being provided with an annular outwardly-extending flange fitted in said groove, substantially as described.

No. 56,377. School Bag. (Sac d'école.)

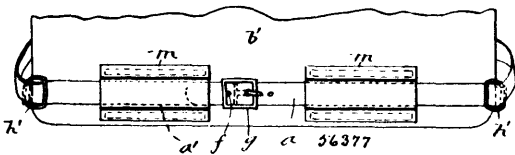

John Alexander Hawthorne, Montreal, Quebec, Canada, 23rd June, 1897; 6 years. (Filed 27th March, 1897.)

Claim.—1st. A school bag comprising a body and flap with a carrying strap secured to the flap, and its projecting lengths passed through rings on the side edges of the bag, for the purpose set forth. 2nd. A school bag comprising a body or flap with a carrying strap secured to the flap, and its projecting lengths passed through rings on the side edges of the bags, and their ends connected to the lower corners of the bag, as shown and described. 3rd. A school bag comprising a body and flap, with a carrying strap secured to the flap and its projecting lengths passed through rings on the side edges of the bag, and through bridge pieces secured upon the body of the bag, for the purpose set forth. 4th. A school bag comprising body b^1 , flap b , strap a, a^1 , having one end provided with perforations f , and a buckle secured to the other end thereof secured by rivet c , and passing through stilts d , in flap through rings e , on side edges of body b^1 , through eyes h^1 at lower corners of body b^1 , and through bridge pieces m , upon the rear side of the body of the bag and said ends a, a^1 , of the strap being connected together by means of said buckles, all substantially as shown and described.

No. 56,378. Advertising Toy. (Jouet.)

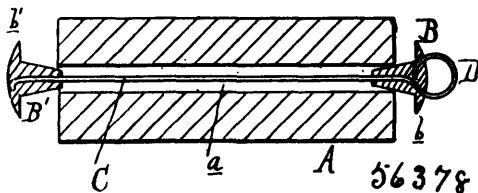

Robert Scribo West, Cleveland, Ohio, U.S.A., 23rd June, 1897; 6 years. (Filed 2nd April, 1897.)

Claim.—A toy consisting of a block of wood having a longitudinal opening therein, a wire passing through said opening, and metallic cones secured upon the ends of said wire, adapted to be turned in frictional contact with said block, substantially as and for the purpose set forth.

No. 56,379. Eyeglass. (Lorgnon.)

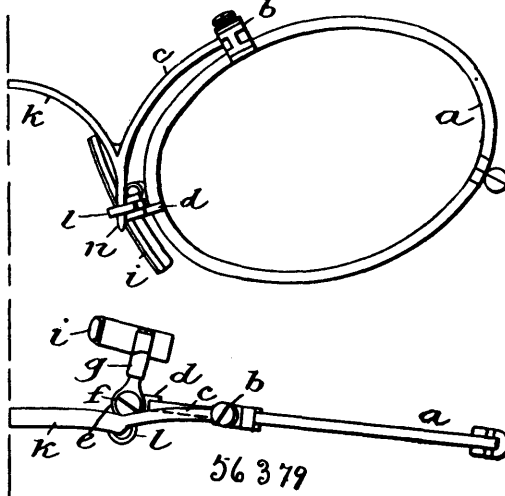

George Culver, Middlesex, London, assignee of Jules Cotlet, France, 23rd June, 1897; 6 years. (Filed 1st April, 1897.)

Claim.—The combination in a flexible eyeglass or "pince-nez" of lens frames, levers pivoted upon the lens frames, a spring or elastic connection between the lens frames, a bridge piece, contact plates or plaquettes mounted upon the levers, and an operative connection between the bridge piece and the levers, substantially as described.

No. 56,380. Rotary Mould. (Moule rotatoire.)

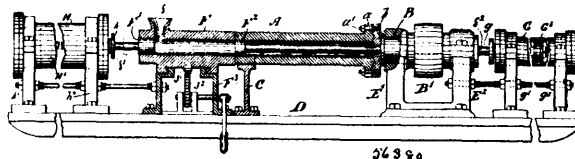

George Howlett Clowes, assignee of Ferdinand Deming, both of Waterbury, Connecticut, U.S.A., 23rd June, 1897; 6 years. (Filed 8th April, 1897.)

Claim.—1st. The combination, with a rotary mould, of two pistons and means for longitudinally moving said pistons into position to form the end walls of said mould, substantially as specified. 2nd. The combination, with a rotary mould, of two pistons, means for longitudinally moving said pistons together into position to form the end walls of the mould, and means for returning said pistons independently of each other, substantially as specified. 3rd. The combination, with a mould, of means for rotating the same, a chamber at one end of the mould, two pistons closing the ends of the chamber, means for moving the pistons along the chamber and for moving one of them into the mould, so that molten metal will be moved from the chamber into the mould. 4th. The combination, with a mould, of means for rotating the same, a chamber located at one end of the mould from which molten metal passes to the mould, and means for causing a relative transverse movement between the mould and the chamber, substantially as specified. 5th. The combination, with a mould, of means for rotating the same, a chamber located at one end of the mould from which molten metal passes to the mould, a piston movable lengthwise of the mould for ejecting a casting therefrom, and means for causing a relative transverse movement between the mould and the chamber, substantially as specified. 6th. The combination of a rotary mould, having a movable end wall as a piston, a receiving chamber, a piston and means for actuating this latter piston to move a mass of molten metal from the chamber into the mould, substantially as specified. 7th. The combination of a rotary mould, a piston movable lengthwise of the mould, a receiving chamber, a second piston and means for causing differential movement of the pistons to move a mass of molten metal from the chamber into the mould and to simultaneously cause an increase in the volume of the space in which the metal is held, substantially as specified.

No. 56,381. Globe Nozzle. (Lance de boyaux.)

The Globe Nozzle Co., Chicago, Illinois, U.S.A., 23rd June, 1897; 6 years. (Filed 9th April, 1897.)

Claim.—1st. The combination of a pipe terminal having an approximately spherical end made in sections and provided with a discharge exit, a cap 10, provided with openings and fitting said pipe end with a universal joint connection, and a perforated packing 5, having a passage closing the joint between the pipe and the cap

in every situation of the latter and also closing the joint between the end sections and co-extensive with the diameter of the spherical

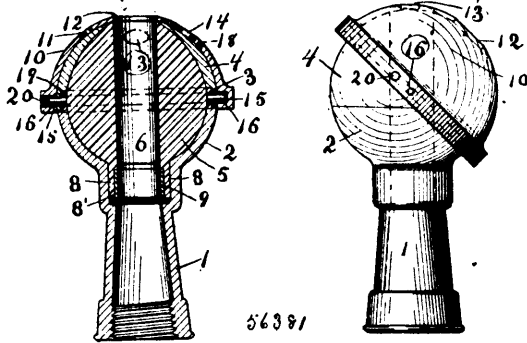

end, substantially as described. 2nd. The combination of a pipe terminal having an approximately spherical end made in sections and provided with a discharge exit, a cap, 10, provided with openings and fitting said pipe end with a universal joint connection, and a perforated packing, 5, having a passage closing the joint between the pipe end and the cap in every situation of the latter and also closing the joint between the end sections and co-extensive with the diameter of the spherical end, said packing having an extension, 8, substantially as described. 3rd. The combination of the pipe terminal having spherical end 2, a hollow hemispherical part 4, secured to said end, a cap 10, having several openings and movable about said parts 4 and 2 to cause any desired opening to register with the pipe passage, and the tubular packing, substantially as described. 4th. In combination with a pipe terminal having an approximately spherical end, an approximately hemispherical cap provided with several perforations and having a groove 16, and pins 15, fixed in the spherical end and situated in said grooves, substantially as described. 5th. In a variable nozzle the combination of a solid rubber sphere having a discharge passage through its centre, enclosed in an approximately spherical end, surmounted by a hemispherical cap having several perforations of different sizes, the cap pivoted on two pins at its base permitting it to partially rotate to expose either of the perforations to the line of discharge or to cut off at will, as and for the purpose above specified.

No. 56,382. Envelope. (Enveloppe.)

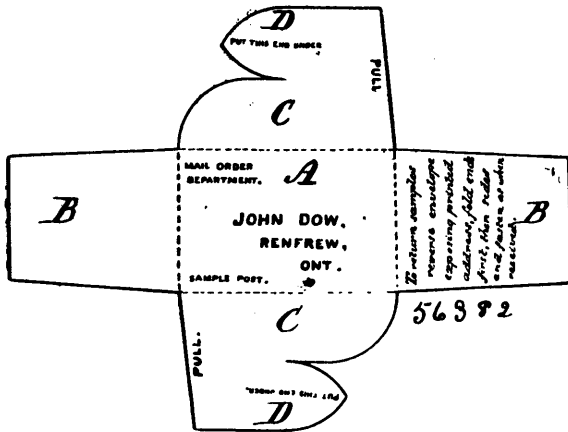

The E. B. Eddy Co., assignee of Robert Erskine Stewart, both of Hull, Quebec, Canada, 23rd June, 1897; 6 years. (Filed 15th April, 1897.)

Claim.—A blank for making a reversible envelope, made in one piece and unglued, and comprising a central rectangular body portion A, inside flaps B, extending therefrom to fold thereon, and outside flaps C, extending from the top and bottom of said body, said outside flaps folding upon the flaps B, and having notched out tongues, D, to interlock, as set forth.

No. 56,383. Offsetting Mechanism for Sawmill Carriages. (Mecanisme compensateur pour chariots de scierie.)

Philip J. Buck and Daniel W. Bennett, both of Thompson, Michigan, U.S.A., 24th June, 1897; 6 years. (Filed 28th May, 1897.)

Claim.—1st. The combination with a sawmill-carriage, of offsetting mechanism, a bar disposed horizontally and connected with

the offsetting mechanism and provided with stops, and a shifting device arranged to slide in and frictionally engage the supporting-

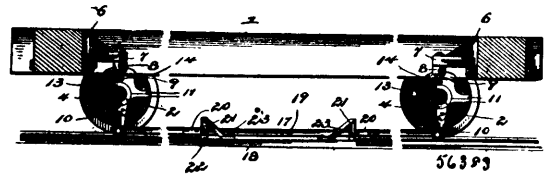

surface, and provided with vertical guides receiving the connecting-bar and located adjacent to said stops, substantially as described. 2nd. The combination of a sawmill-carriage, levers fulcrumed on axles of the carriage and depending therefrom and provided above the same with cam-heads, connected with the sawmill-carriage frame and adapted to move the same laterally, a horizontal bar connecting the levers and frictionally engaged with stops, a rectangular block arranged to slide on and frictionally engage the floor or other supporting-surface, and the vertical guides receiving the horizontal bar and arranged adjacent to the stops, and comprising vertical bars, base plates and inclined braces supporting the vertical bars, substantially as described. 3rd. The combination of a sawmill-carriage, offsetting levers fulcrumed intermediate of their ends on the axles and provided at their upper ends with cam-heads engaging the sawmill-carriage frame, a horizontal bar connecting the depending portions of the levers, a shifting device arranged to slide on and frictionally engage the supporting-surface and provided with vertical guides receiving the horizontal bar, and means for holding the horizontal bar and the shifting device against longitudinal movement on each other, substantially as described. 4th. The combination of a sawmill-carriage, brackets mounted on the sawmill-carriage frame and provided with depending vertically-disposed antifriction-wheels, offsetting levers fulcrumed intermediate of their ends on the axles and provided at their upper ends with cam-heads engaging the antifriction-wheels, a horizontal bar connecting the depending portions of the offsetting levers and provided with stops, and a frictional device arranged to slide on and frictionally engage the supporting-surface, and provided with vertical guides receiving the horizontal bar and located adjacent to said stops, whereby the bar and the shifting device are prevented from moving horizontally on each other, substantially as described.

No. 56,384. Miners' Combination Tool. (Outil pour miner.)

(Outil pour miner.)

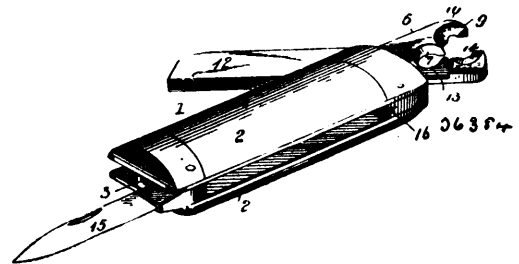

Alfred Strum and Ezekiel R. Dean, both of Wickes, Montana, U.S.A., 24th June, 1897; 6 years. (Filed 19th March, 1897.)

Claim.—1st. In a tool of the character described, the combination with the handle and the slide, formed near one end with a concave cutting edge and at the extremity with a concave jaw, of the lever pivoted to said slide formed with a straight cutting edge and a concave jaw registering with the jaw of the slide and the spring, substantially as described. 2nd. In a tool of the character described, the combination with the handle comprising the sides, the slotted strip, and the slotted block, of the slide, the arms bent over the same and projecting through the slot in said strip and the ends bent at right angles in opposite directions, and said slide formed with a concave cutting edge and a concave jaw, the lever pivoted to said slide formed with a straight cutting edge and a concave jaw, the spring and the pivoted knife blade, substantially as described.

No. 56,385. Sad-iron. (Fer à repasser.)

William E. Hoyt, New York, State of New York, assignee of F. Hagerty, San Francisco, California, both in the U.S.A., 24th June, 1897; 6 years. (Filed 22nd March, 1897.)

Claim.—The herein described sad-iron having the hollow body or chamber, the side air-feeding ducts or flues leading from the upper portion of the body to the base thereof, and base-flue extending from near one end of the chamber to about the centre thereof, the

sliding or movable door or gate in one end of the iron adapted to be tilted inward to rest upon the base-flue, to allow the air to be fed

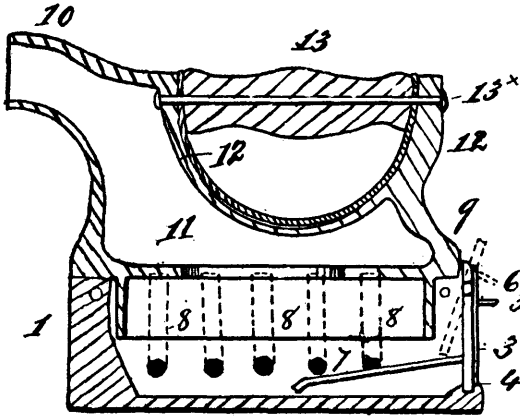

56385

through the base-flue as well as the side flues, and the hollow top for carrying off the products of combustion.

No. 56,386. Feed Cutters. (Coupe-nourriture.)

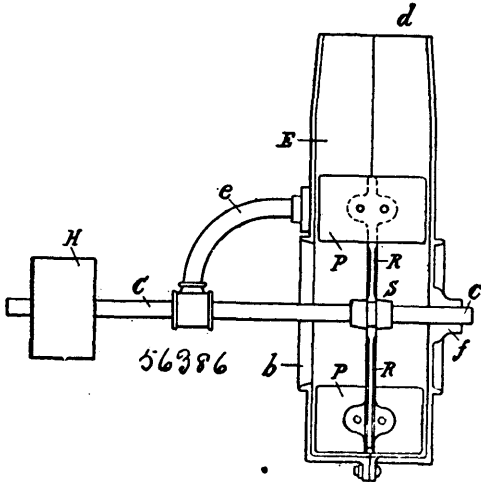

56386

Mark Ashman and William Ashman, both of Nissouri, Ontario, Canada, 24th June, 1897; 6 years. (Filed 4th January, 1896.)

Claim.—1st. In a conveyer attachment for feed cutters, the fan case E, and the conveying tube K, said fan case being provided with the bearing f, the stay or brace e, and the axial inlet opening b, in combination with the fan shaft C, whereby said fan case is pivotally mounted and held in line on said fan shaft, so that it may be adjusted to conduct the cut feed at any angle vertically from the machine at the same time permitting the unobstructed axial inlet opening b, to be formed in said fan case, substantially as and for the purposes set forth. 2nd. In a conveyer attachment for feed cutters, the fan case E, the conveying tube K, and the elbow L, said fan case being provided with the bearing f, the stay or brace e, and the axial inlet opening b, in combination with the fan shaft C, whereby said fan case is pivotally mounted and held in line on said fan shaft, so that it may be adjusted to conduct the cut feed at any angle vertically and in any lateral direction from the machine, at the same time permitting the unobstructed axial inlet opening to be formed in said fan case, substantially as and for the purposes set forth. 3rd. The fan case E, provided with the bearing f, the stay or brace e, and the axial inlet opening b, the fan shaft C, and the fan blades P, in combination with the pulleys G and H, the belt J, and the cutter shaft B, whereby the cut feed or other material is carried forward by the artificial current of air as well as by being thrown forward by the fan blades, at the same time the fan blades operate on a separate and independent shaft and at a different or greater speed than the cutter shaft, substantially as and for the purpose set forth.

No. 56,387. File and Rasp. (Lime et râpe.)

Herman Nass, Pittsburg, Pennsylvania, U.S.A., 24th June, 1897; 6 years. (Filed 29th May, 1897.)

Claim.—1st. In a file, a bar having a shank provided with a screw thread, said bar and shank being slotted to receive a fastening

plate, file plates secured on the bar, a collar engaging the fastening plate, and a handle on the screw-threaded end of the bar, substan-

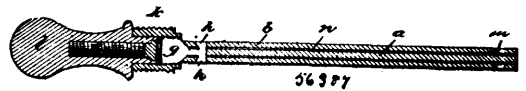

tially as shown and described. 2nd. In a file, a bar, studs secured in the bar near its outer end, a shank formed on its opposite end, said bar and shank being slotted to receive a fastening plate, said plate having lugs to engage the file blades secured on the bar, a handle on the shank and a collar engaging the fastening plate and handle to hold the parts in their position, substantially as shown and described. 3rd. A file, consisting of the file blades secured on a bar, said bar provided with a shank end to receive a handle, a fastening for the file blades, and a collar for securing said blades, substantially as shown and described. 4th. A file, consisting of a bar provided with studs near its one end, a shank formed on its opposite end, a fastening plate in said bar, file blades secured thereon by the studs and fastening plate, a handle on the shank end of the bar, a collar engaging said handle and fastening plate, said bar being provided with a layer of suitable material interposed between the same and the file blade, substantially as shown and described. 5th. In a file, a bar provided at its outer end with means for attachment with the outer ends of the files which are applied to its sides, and at its inner end with a threaded shank, and a slot to receive a clamping or fastening plate, combined with an internally threaded handle, a screw collar secured to the handle, and a clamping or fastening plate placed in the slot in the bar, and which plate has means upon its outer end to engage with the inner ends of the files applied to opposite sides of the bar, and a screw thread upon its inner end to engage with the collar on the handle; and the two files each provided with a perforation at each end, substantially as shown. 6th. In a file, the bar d, provided with a threaded shank c, and slot f, at its inner end, and with the projection m, at its outer end, and the handle l, internally threaded to receive the shank e, and provided with the internally threaded collar k, combined with a separate clamping or fastening plate g, which is placed in the slot f, and which is provided with the hooks or catches h, at its outer end and is screw-threaded at its inner end; and the two files applied to opposite sides of the bar, and provided with perforations at both ends, substantially as shown and described.

No. 56,388. Door Indicator. (Indicateur de portes.)

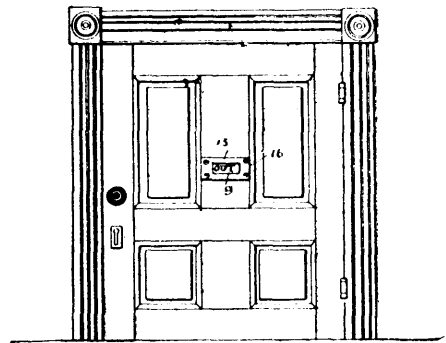

56388

Edward Dundon, Fort Leavenworth, Kansas, U.S.A., 24th June, 1897; 6 years. (Filed 31st March, 1897.)

Claim.—1st. In a door indicator, the combination with a door, of a movable indicator slide carried thereby, and a lever which is pivotally connected to the slide and pivoted to the door, said lever extending transversely through the latter and provided with a free handle. 2nd. In a door indicator, the combination with a door, of a movable indicator slide carried thereby, and a bell crank lever which has one of its arms connected to the slide, and its other arm projecting transversely through the door and provided with a free handle, said lever being pivoted to the door. 3rd. The herein-described door indicator, comprising the combination with a movable indicator slide and a housing therefor which is provided with a sight opening, of mechanism for moving the slide to any desired extent, and springs adapted to co-act with the slide and retain it in position after any degree of adjustment has been effected. 4th. In a door indicator, the combination with a door plate and a housing plate having a sight opening, of an indicator slide movable between the housing plate and door plate, ribbon springs bearing on the indicator slide and serving to hold it in position after adjustment, and an operating lever connected to the indicator slide.

No. 56,389. Label. (Etiquette.)

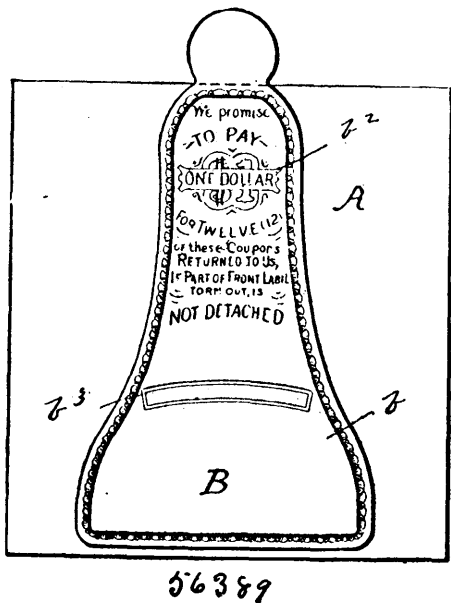

Rudolph August Wittemann, New York, State of New York, U.S.A., 24th June, 1897; 6 years. (Filed 1st April, 1897.)

Claim.—1st. A coupon label device and label comprising a label proper having suitable identifying marks or characters thereon and adapted to be secured to a shipping or other package, together with a coupon secured to said label in such manner that when detached the identifying mark or marks on the label will adhere to the coupon while the label is defaced, said coupon having a portion thereof adapted to be grasped for removing the coupon from the package, whereby the label is adapted to serve as an incentive for selling the particular class of goods contained in the original packages and may be effectually cancelled and the coupon readily identified to prevent fraud, substantially as described. 2nd. In combination with a label having identifying marks or characters thereon and adapted to be secured to a shipping or other package, a coupon representing a certain value secured to the back of the label so as to remove a portion of the latter from the package to which it is applied when the coupon is detached, said coupon being concealed by the label and having its body portion underlying the indentifying mark or marks on the label and adapted to serve as a guide or cutter for removing that portion of the label which adheres to the coupon, and also having a portion thereof exposed to provide a free end or flap adapted to be grasped while removing the coupon from the package, whereby the label is adapted to serve as an incentive to sell the particular class of goods contained in the original package and may be effectually cancelled and the coupon readily identified to prevent fraud, substantially as described. 3rd. A label having identifying marks or characters thereon and adapted to be secured to a shipping or other package, combined with a coupon device also having identifying marks or characters thereon, and consisting essentially of an elongated strip secured to the back of the label and having its body portion formed of different widths, and also having at one end a projecting portion or flap which extends beyond the edge of the label, so as to provide a small exposed portion to be grasped for forcibly removing the coupon with the overlying identifying marks or characters on the label, substantially as described. 4th. The combination with a label having identifying marks or characters thereon and adapted to be secured to a shipping or other package, of a coupon representing a certain value secured to the back of the label so as to remove a portion of the latter from the package to which it is applied when the label is detached, said coupon having its body portion concealed by the label and underlying the identifying mark or marks on the label, and adapted to serve as a guide or cutter for removing that portion of the label which adheres to the coupon, and also having a small portion thereof exposed to provide a free end or flap adapted to be grasped while removing the coupon from the package, whereby the label is adapted to serve as an incentive to sell the particular class of goods contained in the original package, and may be effectually cancelled and the coupon readily identified to prevent fraud, substantially as described. 5th. A label and defacing device, comprising a label proper having suitable identifying marks or characters thereon and adapted to be secured to a shipping or other package, together with a coupon having an enlarged portion intermediate its ends, and secured to said label in such manner that when detached the identifying mark or marks on the label will adhere to the coupon while the label is defaced, said coupon also having a flap projecting beyond the edge of the label and adapted to

be grasped for removing the coupon from the package, whereby the label is adapted to serve as an incentive for selling the particular class of goods contained in the original packages and may be effectually cancelled and the coupon readily identified to prevent fraud, substantially as described.

No. 56,390. Binder for Periodicals. (Reliure.)

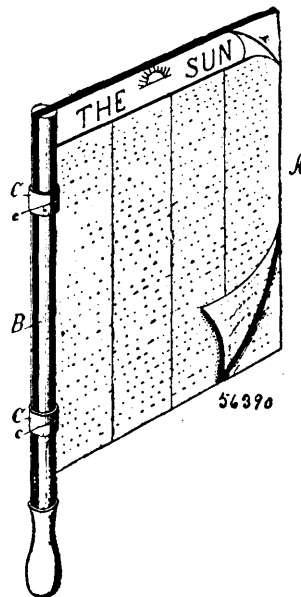

Artemas Melvin Bogle, Towanda, Pennsylvania, U.S.A., 24th June, 1897; 6 years. (Filed 1st April, 1897.)

Claim.—1st. A temporary binder for periodicals, or the like, comprising a spring clip having apertures formed in its opposite ends, and turned-under portions forming loops under said apertures, substantially as described. 2nd. A temporary binder, comprising a single plate of metal bent into an approximately semi-circular form and provided at each end with an aperture, and a loop extending under said apertures so that a space for the insertion of the detaching levers is left below the said aperture, substantially as described.

No. 56,391. Wrench. (Clé à écrou.)

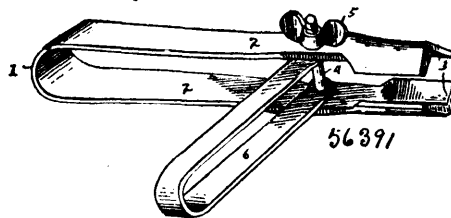

John J. Reinhart, Loogootee, Indiana, U.S.A., 24th June, 1897; 6 years. (Filed 2nd April, 1897.)

Claim.—1st. A wrench consisting of two U-shaped spring members pivoted upon a single bolt, one of said members having opposing jaws at its free ends, and the other member adapted to be swung outward to serve as an operating handle, or to fold out of the way within the other member, substantially as described. 2nd. A wrench comprising spaced connected arms having nut-engaging jaws at their ends, in combination with a bolt connecting said arms for operating the jaws, and an auxiliary handle fulcrumed on said bolt and adapted to fold, substantially as described. 3rd. A wrench comprising connected spaced arms having nut-engaging jaws at their ends, in combination with a bolt connecting said jaws, and an auxiliary handle fulcrumed on said bolt between said arms, said auxiliary handle being in the form of a loop and comprising spring terminal portions which operate upon the aforesaid arms, substantially as described.

No. 56,392. Syrup Drawing Device.

(Appareil pour soutirer le sirop.)

Edward S. Palmbla, Chicago, Illinois, U.S.A., 24th June, 1897; 6 years. (Filed 3rd April, 1897.)

Claim.—1st. In a device for drawing heavy liquids, the combination with a longitudinally reciprocating and laterally oscillating

by the manipulation of said controlling valve, the liquid filtered through the first two compartments may be reversely directed to cleanse the third compartment and by manipulation of said auxiliary valve, be discharged into the said drain pipe, during the continuous delivery of pure filtered liquid from the apparatus, substantially as set forth. 3rd. In a valve, a casing having a plurality of external orifices, a valve plug chamber, a plurality of ports opening into said chamber, a plug fitted to rotate in said chamber and provided with a port, adapted to register with said chamber ports, a plane member of the valve casing adapted to permanently connect the predetermined pair of said chamber ports, by a passage-way in said plane casing members, substantially as set forth. 4th. In a valve, a casing having seven external orifices, a plug chamber, twelve ports opening into said plug chamber, a plug fitted to rotate in said chamber and provided with two ports, adapted to register with said chamber ports, two plane members of said casing each adapted to permanently connect predetermined pairs of said chamber ports by passage-ways in said plane members of the casing, substantially as set forth.

No. 56,395. Gauge. (Jauge.)

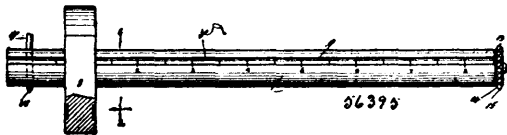

Bert Fuller, Sacramento, California, U.S.A., 24th June, 1897; 6 years. (Filed 7th April, 1897.)

Claim.—1st. A combined rule and scribe, consisting of a body portion, provided with a scale, a sliding block mounted thereon, and a revoluble wheel at one end, said wheel being provided at its perimeter with serrations or teeth, substantially as shown and described. 2nd. A combined rule and scribe, consisting of a body portion, provided with a scale, a sliding block mounted thereon, and a revoluble wheel at one end, said wheel being provided at its perimeter with serrations or teeth, and said body portion being also provided at the end opposite the wheel, with a transverse pointed pin, substantially as shown and described.

No. 56,396. Mucilage Bottle.

(Bouteille à mucilage.)

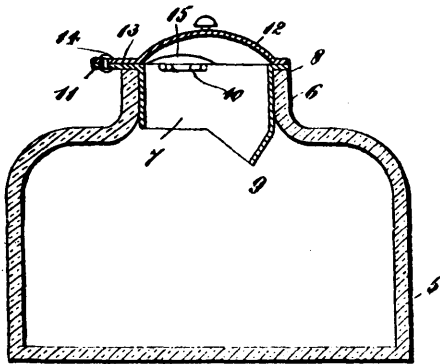

Patrick George McCollam, Canon, Colorado, U.S.A., 24th June, 1897; 6 years. (Filed 7th April, 1897.)

Claim.—1st. A mucilage bottle provided with a neck, and a removable attachment consisting of a short tube, which is adapted to be inserted into the neck, and which is provided with an annular flange which rests thereon, and a cap pivotally connected therewith, substantially as shown and described. 2nd. A mucilage bottle provided with a neck, and a removable attachment consisting of a short tube, which is adapted to be inserted into the neck, and which is provided with an annular flange which rests thereon, and a cap pivotally connected therewith, said tube being provided at its upper end with a spring yoke shaped holder for the handle of the brush, and said cap being provided adjacent thereto, with a semi-circular notch or recess through which the handle of the brush passes, substantially as shown and described. 3rd. A mucilage bottle provided with a neck, and a removable attachment consisting of a short tube, which is adapted to be inserted into the neck, and which is provided with an annular flange which rests thereon, and a cap pivotally connected therewith, said tube being provided at its upper end with a spring yoke shaped holder for the handle of the brush, and said cap being provided adjacent thereto, with a semi-circular notch or recess through which the handle of the brush

passes, and the lower end of the tubular attachment being provided at one side with a segmental inwardly and downwardly directed flange, as and for the purpose set forth.

No. 56,397. Mail Bag. (Sac postale.)

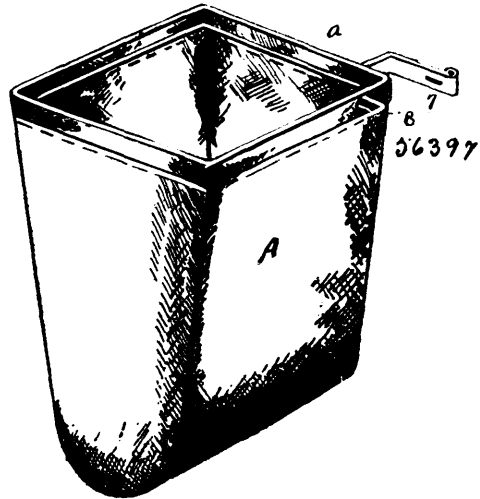

George A. Pile, Jennerstown, Pennsylvania, U.S.A., 24th June, 1897; 6 years. (Filed 7th April, 1897.)

Claim.—1st. The combination of a hinged mouth-frame, composed of hinged parts folding flat, the front of said frame having hooks thereon and the rear of the frame having apertures therein, hinged slides upon the rear of the frame having afterwards adapted to receive the hooks, an eye upon the front of the bag, a hasp pivoted to the slides and adapted to move the slides, a spring having its opposite ends secured to the said frame and slides, and adapted to throw the slides upon the release of the hasp, and a spring-lock contained within the material of the bag and adapted to lock one of the slides to the adjoining part of the frame. 2nd. In a mail bag, the combination with a bag provided at its upper end with a channel, of a locking device seated in said channel and consisting of a sliding bar designed to engage flanged fingers, a coiled spring connected to said sliding arm, the opposite end bearing against the frame in the channel of the bag, and a safety-catch located in a slot in the frame having one end secured to said frame, the opposite end working freely in a slot in the sliding locking-bar, and a lug on the catch to engage the end of the slot of the sliding locking-bar.

No. 56,398. Pneumatically Operated Organ. (Orgue.)

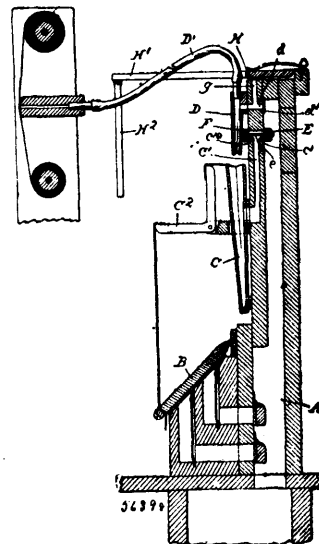

Melville Clark, Chicago, Illinois, U.S.A., 24th June, 1897; 6 years. (Filed 9th April, 1897.)

Claim.—1st. In a pneumatic organ, in combination with an exhaust wind-chest, a primary pneumatic and a motor pneumatic, both exterior to the wind-chest and communicating therewith for exhausting and, with the outer air, for venting said pneumatics; the

valves which control the exhaust and vent ports of the motor pneumatic being connected to and operated by the primary pneumatic to exhaust the motor pneumatic when the primary pneumatic is vented, and to vent said motor pneumatic when the primary pneumatic is exhausted; connections from the motor pneumatic by which the sound-producing devices are caused to speak when said motor pneumatic is collapsed, and suitable means for uncovering the vent of the primary pneumatic; the vent valve of the motor pneumatic being at its seat normally under the influence of gravity when free from any influence proceeding from the wind-chest. 2nd. In a pneumatic organ, in combination with an exhaust wind-chest, a primary pneumatic and a motor pneumatic both exterior to the wind-chest and communicating therewith for exhausting and, with the outer air, for venting said pneumatics; the valves which control the exhaust and vent ports of the motor pneumatic being connected to and operated by the primary pneumatic to exhaust the motor pneumatic when the primary pneumatic is vented, and to vent said motor pneumatic when the primary pneumatic is exhausted; connections from the motor pneumatic by which the sound-producing devices are caused to speak when said motor pneumatic is collapsed, and suitable means for uncovering the vent of the primary pneumatic; the vent valve of the motor pneumatic and its connection to the primary pneumatic being exterior to the wind-chest, said primary pneumatic being adapted normally under the influence of gravity and when free from any influence proceeding from the wind-chest to stand expanded and in position to hold said valve at its seat. 3rd. In a pneumatic organ, in combination with an exhaust wind-chest, a primary pneumatic and a motor pneumatic both exterior to the wind-chest and communicating therewith for exhausting and, with the outer air, for venting said pneumatics; the valves which control the exhaust and vent ports of the motor pneumatic being connected to and operated by the primary pneumatic to exhaust the motor pneumatic when the primary pneumatic is vented, and to vent said motor pneumatic when the primary pneumatic is exhausted, connections from the motor pneumatic by which the sound-producing devices are caused to speak when said motor pneumatic is collapsed, and suitable means for uncovering the vent of the primary pneumatic; said primary pneumatic being adapted normally when vented and thereby relieved from the influence of the wind-chest, to expand by the action of gravity on its moving wall to the extent necessary to hold the exhaust valve of the motor pneumatic off its seat and the vent valve of said pneumatic at its seat. 4th. In a pneumatic organ, in combination with an exhaust wind-chest, a primary pneumatic and a motor pneumatic, both exterior to the wind-chest, and communicating therewith for exhausting and with the outer air for venting said pneumatics, the valves which control the exhaust and vent ports of the motor pneumatic being connected to and operated by the primary pneumatic to exhaust the motor pneumatic when the primary pneumatic is vented, and to vent said motor pneumatic when the primary pneumatic is exhausted, connections from the motor pneumatic by which the sound-producing devices are caused to speak when said motor pneumatic is collapsed, and suitable means for uncovering the vent of the primary pneumatic, the exhaust communication of the primary pneumatic with the wind-chest being restricted relatively to the vent of said primary pneumatic, and the vent valve of the motor pneumatic being adapted normally, under the influence of gravity, when the primary pneumatic is vented, to stand at its seat. 5th. In a pneumatic organ, in combination with an exhaust wind-chest, a primary pneumatic and a motor pneumatic, both exterior to the wind-chest, and communicating therewith for exhausting and with the outer air for venting said pneumatics, the valves which control the exhaust and vent ports of the motor pneumatic being connected to and operated by the primary pneumatic to exhaust the motor pneumatic when the primary pneumatic is vented, and to vent said motor pneumatic when the primary pneumatic is exhausted, connections from the motor pneumatic by which the sound-producing devices are caused to speak when said motor pneumatic is collapsed, the moving wall of the primary pneumatic being pendulous and at normal position under the influence of gravity when said pneumatic is vented and freed from the influence of the wind-chest, adapted to hold the motor pneumatic vent valve at its seat. 6th. In combination with the wind-chest, a primary pneumatic and a motor pneumatic whose communication with the wind-chest is controlled by the primary pneumatic, the valve which effects such control having its stem tubular and constituting a communicating duct between the wind-chest and the primary pneumatic. 7th. In combination with the wind-chest, a primary pneumatic and a motor pneumatic, having its communication with the external air controlled by the primary pneumatic, the valve which effects such control having its stem tubular and constituting the communicating passage between the wind-chest and the primary pneumatic. 8th. In combination with the wind-chest, the primary pneumatic exterior thereto and a motor pneumatic, whose communication is controlled by the primary pneumatic, the valve which effects such control having its stem tubular and constituting a communicating duct between the wind-chest and the primary pneumatic. 9th. In combination with the wind-chest, a primary pneumatic exterior thereto, a motor pneumatic also exterior thereto, valves which control the communication of the motor pneumatic with the wind-chest and with the external air being operated by the primary pneumatic and being mounted on a common stem, said stem being tubular and constituting the communication between the wind-chest and the

primary pneumatic. 10th. In combination with the wind-chest and an exterior primary pneumatic, a tube which is attached to the fluctuating wall of the pneumatic and which extends into the wind-chest constitutes the means of communication between the wind-chest and the pneumatic, and a pallet or valve within the pneumatic adapted to be seated over the inner port of said tube when the pneumatic is collapsed. 11th. In combination with the wind-chest, a primary pneumatic exterior thereto and a motor pneumatic, whose communication with the wind-chest and with the outer air is controlled by the primary pneumatic, the valve which effects such control having its stem tubular and constituting the communicating duct between the wind-chest and the pneumatic, and a pallet or seat within the primary pneumatic, on which the inner port of said duct seats when the pneumatic is collapsed.

No. 56,399. Organ. (Organ.)

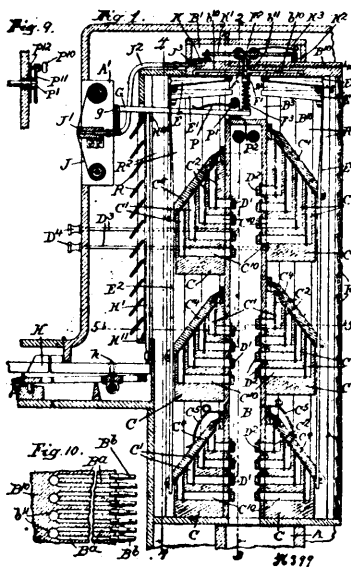

Melville Clark, Chicago, Illinois, U.S.A., 24th June, 1897; 6 years.
(Filed 9th April, 1897.)

Claim.—1st. In an organ, in combination with the manual, and the valves which control the sounding devices, an air chamber and the pneumatics communicating with such chamber arranged in a plurality of horizontal rows and connected to and operating said valves respectively, valves which control the communications of said pneumatics respectively with the air chamber and connections from said valves respectively arranged in parallel vertical fore-and-aft planes and extending to the respective keys of the manual. 2nd. In a pneumatic organ, in combination with an air chamber having ports leading through its wall, valves which control said ports respectively and means for operating the same, a plurality of ducts leading into said ports and a plurality of pneumatics connected with such ducts respectively and valves which control the sounding devices corresponding to and operated by said pneumatics respectively. 3rd. In a musical instrument in which the valves which control the action of the air upon the sounding devices are operated by pneumatic motors, manual keys and the wind-chest, said sounding-device-controlling valves, and connections therefrom to the motors being exterior to the wind-chest, valves which control communication between the pneumatic motors respectively and the wind-chest, and mechanical connections from the keys of the manual to the latter valves respectively. 4th. In a musical instrument in which the valves which control the action of the air upon the sounding devices are operated by pneumatic motors and in which the said valves and pneumatic motors are exterior to the wind-chest, manual keys and mechanical connections therefrom to the valves which control the communication between the pneumatic motors and the wind-chest, the pneumatic motors and said mechanical connections being exterior to the wind-chest. 5th. In an organ, in combination with a vertical wind-chest, reed-chambers mounted upon the vertical sides thereof in vertical rows, exterior valves for said reed-chambers respectively, pneumatic motors located exterior to the wind-chest in line with said vertical rows of valves, and connections from said pneumatic motors to the several valves in their respective rows, the valves which control communication of said pneumatic motors respectively with the wind-chest, and suitable means for operating said latter valves. 6th. In an organ, in combination with a manual and the wind-chest, reed-chambers mounted on the vertical sides of the wind-chest in vertical rows, exterior valves for such reed-chambers respectively, pneumatic motors located exterior to the wind-chest in line with the vertical rows respectively of reed-chamber-valves, connections from the pneumatic motors respectively to the several valves in their respective vertical rows, valves which control

communication from the wind-chest to the pneumatic motors respectively, and mechanical connections to said valves from the keys of the manual respectively. 7th. In an organ, in combination with the reed-chambers mounted upon the vertical sides of the wind-chest in vertical rows, exterior valves for the said reed-chambers respectively, pneumatic motors located exterior to the wind-chest in line respectively with the vertical rows of valves and above said rows, and provided with connections downward to the several valves, valves which control the communication of the pneumatic motors respectively with the wind-chest, and suitable means for operating said latter valves. 8th. In an organ, in combination with a wind-chest erected vertically, reed-chambers mounted on the vertical sides thereof in vertical rows, downwardly seating valves for said reed-chambers, pneumatics mounted in line with said vertical rows respectively and above the same, mechanical connections from the pneumatics to the uppermost valves of their respective rows, and from each such valve successively to the one below it in the row, and a spring acting upon the lowest valve in the row, tending to seat the same and thereby seat all the valves above it in the row. 9th. In an organ, in combination with the manual, a wind-chest erected vertically and having at its upper side a horizontal extension, reed-chambers mounted upon the vertical wall of the wind-chest, pneumatic motors mounted on the under side of said horizontal extension above the reed-chambers respectively, downwardly seating valves for said reed-chambers and connections thereto from the pneumatics above them respectively. 10th. In an organ, in combination with the manual, a wind-chest erected vertically and having at its upper side a horizontal extension, reed-chambers mounted upon the vertical wall of the wind-chest, pneumatic motors mounted on the under side of said horizontal extension above the reed-chambers respectively, downwardly seating valves for said reed-chambers and connections thereto from the pneumatics above them respectively, the valves which control communication of said pneumatics respectively with the wind-chest, and mechanical connections from the keys of the manual respectively to said latter valves. 11th. In an organ, in combination with the manual, the wind-chest erected vertically and having at its upper end a supplementary portion extended horizontally forward and rearward beyond the front and rear vertical walls of the main portion, reed-controlling valves mounted on the front and rear sides of said main portion, pneumatic motors arranged in pairs, individuals of which are located above the front and rear reed-controlling valves respectively and mounted upon the horizontally extended supplemental portion of the wind-chest and communicate therewith, a valve for each pair of pneumatics controlling the communication of both individuals of the pair with the wind-chest, and mechanical connections from the keys of the manual to said latter valves respectively. 12th. In an organ, in combination with the wind-chest, pneumatics mounted exteriorly thereon corresponding respectively to the several notes or pitches to be sounded, a plurality of reed-controlling valves corresponding to each note or pitch, and connections from such valves respectively to the corresponding pneumatics, valves which control communication between the pneumatics respectively and the wind-chest, and suitable means for operating said pneumatic-controlling valves whereby said pneumatic operates a plurality of reed-valves corresponding to the same pitch. 13th. In a reed organ, a block having formed in it a plurality of chambers for reeds pertaining to the same set, separate valves which control said chambers respectively at the speaking side of the reed, the chambers merging at the opposite side of the reeds in a common throat leading from the reeds to the wind-chest. 14th. In a reed organ, a block having formed in it chambers for reeds pertaining to a plurality of sets, the reeds of each set having extended groups of contiguous chambers merging in a common throat which extends from the reeds to the wind-chest, and mutes which control said throats at their emergence into the wind-chest. 15th. In a reed organ, a block having individual chambers for the several reeds of a plurality of sets, corresponding individuals of the several sets having the chambers opening at an exterior surface of the block in rows transverse to the rows which constitute the said sets respectively, valves which control said transverse rows respectively, the several sets of reeds having extended groups of their contiguous chambers merging at the side of said reeds toward the wind-chest in throats or passages which are common to all the individuals of said groups respectively, such throats or passages extending from the reeds to the wind-chest, and mutes which control the throats at their openings into the wind-chest. 16th. In a reed organ, in combination with a wind-chest, a block mounted thereon having chambers for reeds pertaining to a plurality of sets, those of each set being arranged in a row extending right and left, said rows being successively more and more remote from the wind-chest, throats or passages from the inner ends of said reed-chambers, extended groups of the reed chambers of the several sets respectively having a common or single throat or passage-way, whose lateral extent is the total lateral extent of all the reed chambers of such group. 17th. In a reed organ, in combination with a wind-chest erected vertically, a reed block mounted upon one of the vertical sides thereof, having its upper and beveled end sloping down away from the wall of the wind-chest, reed chambers pertaining to a plurality of sets of reeds formed vertically in such block and arranged set by set in rows which are successively more and more remote from the wind-chest, and such chambers emerging through such sloping surface, and throats or passages from their lower ends respectively leading into the wind-chest, extended

groups of contiguous reed chambers in the respective sets, having their throats or passages to the wind-chest merged in one.

No. 56,400. Valve. (Soupape.)

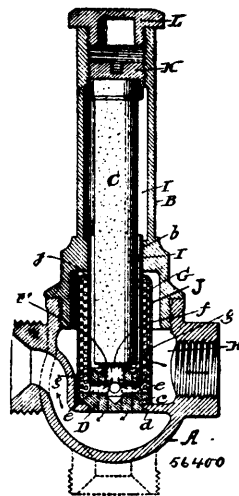

Warren Webster & Co., Camden, assignee of John A. Serrell, Bayonne, and Meredith Leith, Merchantville, all in the U.S.A., 25th June, 1897; 6 years. (Filed 12th April, 1897.)

Claim.—1st. The combination with the expanding piece of a thermostatic valve, of the protecting casing about the expanding piece to protect it from direct contact with the steam until it has passed through the valve as set forth. 2nd. A thermostatic valve for a "vacuum system," divided internally into a vacuum and a pressure chamber, and having the expanding piece located in the vacuum chamber, whereby it is subjected to steam at low temperature and pressure as described and for the purpose set forth. 3rd. The combination with the expanding piece of a thermostatic valve, of the valve seat having its inlet passage-way extending forward from below the expanding piece so that the flow of air and vapour takes place in a direction opposite to the expansion of the expanding piece as described. 4th. A thermostatic valve having the inlet chamber of the body divided into two compartments communicating with one another only through a passage-way of the valve-seat piece, and having an expanding piece located in the compartment of the inlet chamber on the discharge side of the valve-seat piece as shown and set forth. 5th. A thermostatic valve having its body provided with an internal chamber having an inlet passage-way leading into it, and an independent discharge passage-way leading from it, and an expanding piece located in said internal chamber and controlling one of said passage-ways only as set forth. 6th. A thermostatic valve having its body provided with an internal closed compartment, a valve seat piece having inlet passage-way *c f* leading into said compartment, and independent outlet passage-way *g* leading therefrom, and an expanding piece located in the compartment and controlling the inlet passage-way *c f* only as described. 7th. The combination with the removable valve seat piece *D* having inlet passage-way *c f* and outlet passage-way *g*, of the casing *G* connected with the removable seat piece *D*, and forming, when applied to the valve-body, a closed compartment as set forth and shown. 8th. The removable cap or bonnet carrying the casing *G* and valve seat piece *D* as set forth and for the purpose mentioned. 9th. The removable screen loosely supported by the removable casing *G*, as and for the purpose hereinbefore set forth.

No. 56,401. Leaf Turner. (Tourne-feuille.)

Joseph Berron, Jackson, Maine, U.S.A., 25th June, 1897; 6 years. (Filed 12th April, 1897.)

Claim.—1st. In a leaf turner, the combination with a base, a post secured thereto, and a desk carried by the said post, of arms pivoted to the desk and provided at their front ends with clips for engaging with the leaves, pedals pivoted to the base, cords attached to the rear ends of the said arms and running in opposite directions and attached to the said pedals, and guide pulleys for supporting the cords, substantially as set forth. 2nd. In a leaf turner, the combination with a base, a post secured thereto, a post slidable in the aforesaid post, and a desk secured to the said slidable post, of arms pivoted to the said desk, pedals pivoted to the said base, cords connected to the said arms and pedals, guide pulleys for the cords supported by the said desk, post and base, and slidable guide pulleys operating automatically to keep the said cords taut when the

slidable post is moved vertically, substantially as set forth. 3rd. In a leaf turner, the combination with a stationary hollow post B

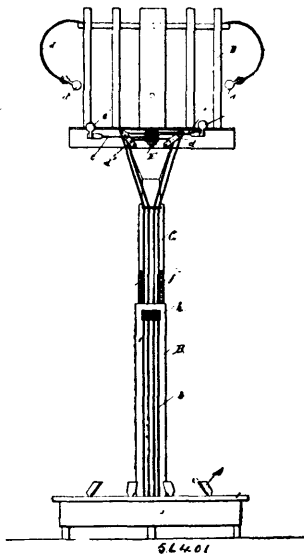

provided with toothed racks, of a slidable post C also provided with toothed racks, plates guiding the post C in the post B, toothed pinions gearing into the rack on the posts B and C, a shaft carried by the said pinions, guide pulleys *g*¹ journaled on the said shaft, guide pulleys *h* carried by the upper part of the post B, leaf turning arms supported by the post C, and operating cords attached to the said arms and passing under the pulleys *g*¹ and over the pulleys *h*¹, substantially as set forth. 4th. The combination with the stationary hollow post B, and the post C slidable therein, of brackets secured to the post B, and an eccentric journaled in the said brackets and bearing against the back of the post C, so that the said post C may be clamped in any position, substantially as set forth.

No. 56,402. Mucilage Bottle. (Bouteille à mucilage.)

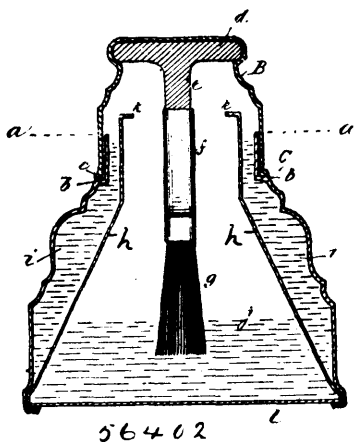

John Lindsay, assignee of Thomas Alexander Fick, both of Paris, Ontario, Canada, 25th June, 1897; 6 years. (Filed 14th April, 1897.)

Claim.—1st. A bottle for mucilage or other liquids, constructed with an inner and an outer wall, and a water reservoir space between said walls, substantially as specified. 2nd. A bottle for mucilage or other liquids, constructed with an inner and an outer wall and a water reservoir chamber between said walls, the inner wall higher than the outer wall, and the top edge turned inward to form a flange to clean the brush, substantially as described. 3rd. A bottle for mucilage and other liquids, constructed with inner and outer walls, the outer wall formed with an annular projection a short distance from its mouth, and a cover formed with a corresponding annular projection on the exterior wall, to prevent water from evaporating from the water chamber between the two said walls, substantially as specified. 4th. In combination with a bottle formed with exterior and interior walls, and a water reservoir space

between said walls, constructed with an annular cap held in the inside of the cover and a pin or projection depending from said cap, upon which is held the ferrule of a brush, the cover forming a convenient handle to hold the brush or spreading device, substantially as specified. 5th. A bottle for mucilage or other liquids, consisting of the combination of outer and inner walls A, *h*, a water space *i* between said walls, flange *b* on the outer wall, wiper flange *k* on the top of the inner wall, the cover B enclosing the wood cap *d* and projection *c* to hold the ferrule *f*, of the brush *g*, all constructed substantially as and for the purpose specified.

No. 56,403. Safety Cut-off for Gas Burners.

(*Détente de sûreté pour brûleurs à gaz.*)

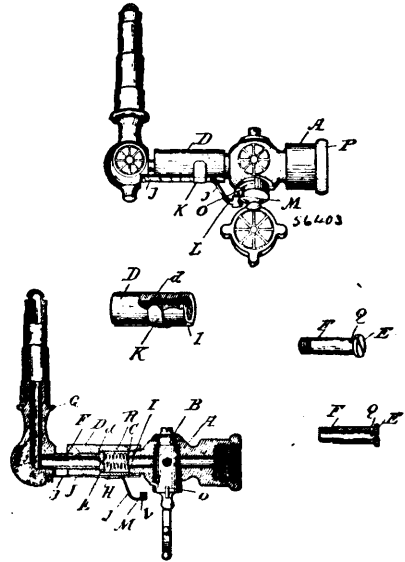

Philip C. Folwell, George H. Leslie and George Hambly, all of Toronto, Ontario, Canada, 25th June, 1896; 6 years. (Filed 17th April, 1897.)

Claim.—1st. In a safety cut-off for gas burners, the combination of the main valve, controlling the passage of the gas from the gas pipe, and a secondary valve to automatically close the passage from the main valve to the burner, after the main valve has been closed, or partially closed, to extinguish the light, substantially as specified. 2nd. In a safety cut-off for gas burners, the combination of the main valve, the burner, a cylindrical passage from the main valve to the burner, a secondary valve controlling the gas from the cylindrical passage, automatically operated to close the passage after the operation of the main valve, to cut off the gas from the gas pipe, substantially as specified. 3rd. A safety cut-off for gas burners consisting of a main valve, the burner, a cylindrical passage from the main valve to the burner, a spring operated piston valve to close the cylindrical passage after the main valve has been turned sufficiently to extinguish the light, substantially as specified. 4th. In a safety cut-off for gas burners, the combination of the main valve, the burner, a cylindrical passage from the main valve to the burner, and a spring operated piston valve within the cylindrical passage, substantially as specified. 5th. In a safety cut-off for gas burners, the combination of the main valve, a cylinder connected to the main valve, a valve seat within the cylinder, the burner, a piston valve to engage the valve seat, and a hollow piston rod connected to the piston valve and burner, substantially as specified. 6th. In a safety cut-off for gas burners, the combination of the main valve, a cylinder connected to the main valve, a valve seat within the cylinder, the burner, a piston valve to engage the valve seat, a hollow piston rod connected to the piston valve and burner, a guide rod connected to the burner, a guide embracing the cylinder and guide rod, a spring latch connected to the guide rod, and a catch connected to the main valve plug, adapted to engage the latch, substantially as specified.

No. 56,404. Car Coupler. (Attelage de chars.)

David K. Clark, William H. Frater, both of Upper Sandusky, Elmore H. Conaway and William R. Conaway, both of Caledonia, all in Ohio, U.S.A., 25th June, 1897; 6 years. (Filed 3rd May, 1897.)

Claim.—1st. In a car-coupler, a draw-bar having a forward longitudinal chamber therein, a knuckle pivotally connected to said draw-bar, a locking-arm pivotally connected to said knuckle and working in said chamber, and a locking-pin adapted to engage said locking-arm, substantially as set forth. 2nd. In a car-coupler, a draw-bar having a forward longitudinal chamber therein, a knuckle pivotally connected to said draw-bar, a headed locking-arm pivot-

ally connected to said knuckle and working in said chamber, and a locking-pin having an opening adapted to receive and engage the

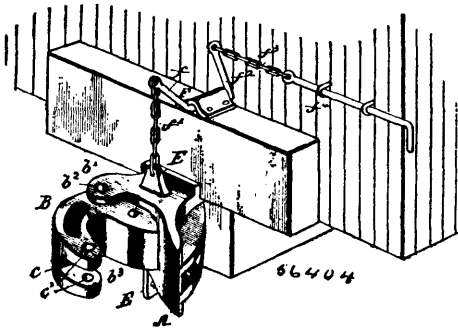

headed end of said locking-arm, substantially as set forth. 3rd. In a car-coupler, a draw-bar having a forward longitudinal chamber therein, a knuckle pivotally connected to said draw-bar, a headed locking-arm pivotally connected to said knuckle and working in said chamber, and a locking-pin having a hole or opening therein adapted to receive the headed end of said locking-arm and having a slot extending from said opening with the edges of which said headed end is designed to engage, substantially as set forth. 4th. In a car-coupler, a draw-bar having a forward longitudinal chamber therein, ears or lugs projecting from the forward end of said draw-bar, a knuckle provided with a web or flange pivotally secured between said ears or lugs, a spring for normally holding said knuckle open or unlocked, a stop for limiting the outward movement of said knuckle, a headed locking-arm pivotally connected to said knuckle and adapted to work in said chamber, and a locking-pin adapted to engage the headed end of said locking-arm, substantially as set forth.

No. 56,405. Musical Instrument.

(Instrument de musique.)

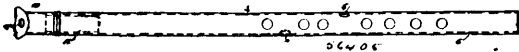

Carlo Tomaso Giorgi, New York, State of New York, U.S.A., 25th June, 1897; 6 years. (Filed 10th April, 1897.)

Claim.—1st. A mouth-piece for a flute, having a substantially cylindrical chamber, and a mouth-hole in the longitudinal line of the flute, substantially as specified. 2nd. A mouth-piece for a flute, of cylindrical form and having a resounding chamber 12, 13, and having a mouth-hole in a direct line with the bore of the flute, said mouth-piece being curved relatively to the flute, substantially as specified. 3rd. A flute having eleven finger-holes, the first one of which is arranged out of line with the second hole, whereby the phalange of the first finger may engage over the first hole and the said finger engage with the second hole, whereby all of the eleven holes may be controlled by the ten fingers of a player, substantially as specified.

No. 56,406. Moistening Machine.

(Machine à humecter.)

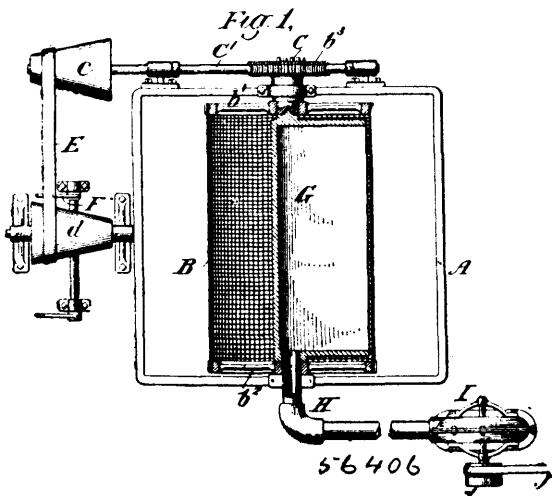

Pierre Lorillard, jr., Tuxedo Park, New York, U.S.A., 25th June, 1897; 6 years. (Filed 12th April, 1897.)

Claim.—1st. The combination of a foraminous or reticulated screen, means for supplying the screen with particles of liquid, a discharge device on one side of the screen, and means for forcing fluids through the discharge device and the screen to project the liquid carried by the latter in a finely divided state, substantially as specified. 2nd. The combination of a tank containing liquid, a movable foraminous or reticulated screen dipping into said tank, and adapted to elevate particles of liquid therefrom, a discharge device on one side of the screen, and means for forcing fluid through the discharge device and the screen to project the liquid carried by the latter in a finely divided state, substantially as specified. 3rd. The combination of a tank containing liquid, a foraminous or reticulated screen movable therein and arranged to elevate particles of liquid from the tank, and means for forcing said particles of liquid from the screen in a finely divided state, substantially as specified. 4th. The combination of a tank containing liquid, a cylindrical foraminous or reticulated screen dipping therein and adapted to elevate particles of liquid from the tank, a discharge device mounted centrally within the screen and having its point of discharge at or near the periphery of the screen, and means for rotating the latter, substantially as specified.

No. 56,407. Bacon and Ham Suspender and Advertiser.
(Appareil pour suspendre les jambons.)



John Wynn, Cardiff, South Wales, G. B., 25th June, 1897; 6 years. (Filed 12th April, 1897.)

Claim.—1st. A device for suspending bacon, ham and the like, consisting of a wire or rod B, having an eye C, or loop at one end, in combination with a cross-piece A, rigidly connected to the wire at the other end, substantially as described. 2nd. A bacon or ham suspender, comprising a twisted wire B, looped at its upper end, and rigidly connected to a cross bar A, at its lower end, substantially as described.

No. 56,408. Spring Tension Adjuster.

(Resort à tension pour moulin à vent.)

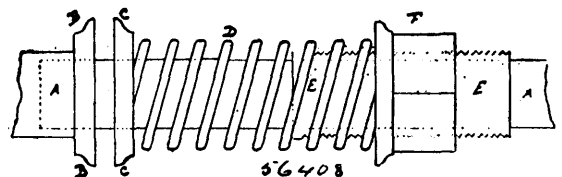

Edward Smart, Toronto, Ontario, Canada, 25th June, 1897; 6 years. (Filed 12th April, 1897.)

Claim.—The combination in a windmill or air motor of a sleeve and a nut travelling thereon, for the purpose of regulating the pressure of the spring of a safety clutch, substantially as hereinbefore set forth.

No. 56,409. Apparatus for Compressing Air.

(Machine de compression pour l'air.)

Merrill E. Clark, Worcester, Mass., U.S.A., 25th June, 1897; 6 years. (Filed 12th April, 1897.)

Claim.—1st. In apparatus for compressing air, the combination of a shaft, having at one end a piston adapted to be moved, and a piston at the opposite end of said shaft adapted to act upon a volume of air in the cylinder of an air-compressor, and an intermediate disc, and

mechanism for imparting motion to said disc, whereby said pistons may be returned to their initial positions after the completion of the

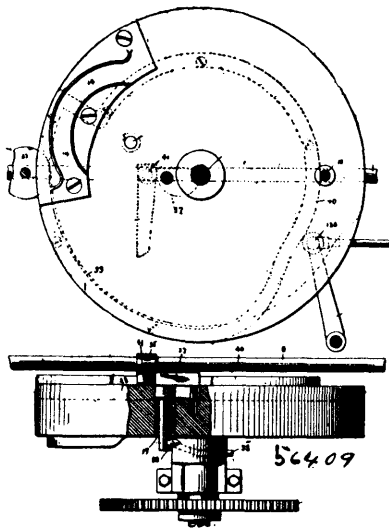

stroke, substantially as described. 2nd. In apparatus for compressing air, the combination of a shaft, having at one end a piston adapted to be moved, and a piston at the opposite end of said shaft adapted to act upon a volume of air in the cylinder of an air-compressor, and an intermediate disc provided with a projection adapted to contact with an arm attached to said shaft, and mechanism for imparting motion to said disc, whereby said pistons may be returned to their initial positions after the completion of the stroke, substantially as described. 3rd. In apparatus for compressing air, the combination of a shaft, having at one end a piston adapted to be moved, and at the opposite end of said shaft a piston adapted to act upon a volume of air in the cylinder of an air-compressor, and an intermediate disc provided with a cam adapted to contact with a roll on said shaft, and provided with a projection adapted to contact with an arm attached to said shaft, and mechanism for imparting motion to said disc, whereby an incomplete stroke may be completed and said pistons returned to their initial positions after the completion of the stroke, substantially as described. 4th. In apparatus for compressing air, the combination of a shaft, having at one end a piston adapted to be moved and at the opposite end of said shaft a piston adapted to act upon a volume of air in the cylinder of an air-compressor, mechanism for gripping said shaft, and an intermediate disc provided with a cam adapted to contact with a roll on said shaft, and provided with a projection adapted to contact with an arm attached to said shaft, and a cam-path adapted to actuate a roll which imparts a thrust to a bar connected with said gripping mechanism, and mechanism for imparting motion to said disc, whereby said shaft may be gripped and an incomplete stroke may be completed and the grip upon said shaft may be released and said pistons returned to their initial positions, substantially as described. 5th. In apparatus for compressing air, the combination of a shaft, having at one end a piston adapted to be propelled by an explosion, and at the opposite end a piston adapted to act upon a volume of air in the cylinder, of an air-compressor, and an intermediate disc provided with suitable cam-paths, and rolls adapted to travel in said cam-paths, said disc being provided with a projection adapted to contact with an arm attached to said shaft and suitably connected with the exhaust and supply valves of an engine, and properly timed, and mechanism for imparting motion to said disc, whereby the exhaust-valve may be opened by the progress of a roll through one of said cam-paths and said pistons returned to their initial positions, and the explosive supplied to the cylinder of the engine by the progress of a roll through another of said cam-paths, substantially as described. 6th. In apparatus for compressing air, the combination of a shaft, having at one end a piston adapted to be propelled by an explosion, and at the opposite end a piston adapted to act upon a volume of air in the cylinder, of an air-compressor, and an intermediate disc provided with suitable cam-paths and provided with a cam adapted to contact with a roll on said shaft, and provided with a projection adapted to contact with an arm attached to said shaft, said disc being suitably connected with the exhaust and supply valves and properly timed, and mechanism for imparting motion to said disc whereby an incomplete stroke may be completed, the exhaust-valve opened, said pistons returned to their initial positions, and the explosive supplied to the cylinder of the engine, substantially as described. 7th. In apparatus for compressing air, the combination of a shaft, having at one end a piston adapted to be propelled by an explosion, and at the opposite end a piston adapted to act upon a volume of air in the cylinder, of an air-compressor, to which cylinder is secured mechanism for gripping

said shaft, and an intermediate disc provided with suitable cam-paths and provided with a cam adapted to contact with a roll on said shaft, and provided with a projection adapted to contact with an arm attached to said shaft, and a cam-path adapted to actuate a roll which imparts a thrust to a bar connected with said gripping mechanism, said disc being suitably connected with the exhaust and supply valves and properly timed, and mechanism for imparting motion to said disc whereby said shaft may be gripped, an incomplete stroke may be completed, the gripping mechanism disengaged, the exhaust-valve opened, said pistons returned to their initial positions, and the explosive supplied to the cylinder of the engine, substantially as described.

No. 56,410. Computing Machine. (Machine à compter.)

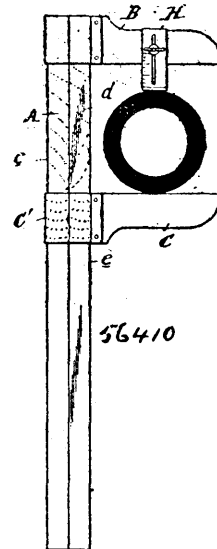

Alfred E. Putman, Milan, Michigan, U.S.A., 25th June, 1897; 6 years. (Filed 12th April, 1897.)

Claim.—1st. A computing caliper, comprising a shank having arranged longitudinally and side by side thereon, a progressive series of diminished scales formed by dividing a given unit by different numbers, a fixed caliper arm at one end of said shank, and a sliding arm on said shank carrying a number opposite each scale on the shank corresponding to the number used in forming said scale. 2nd. A computing caliper, comprising a tabulated shank having a fixed arm at one end thereof, and a sliding arm sleeved thereon, said shank having a rhombic cross-section forming the faces *a, b, c* and *d* on which the numbers or scales are placed in longitudinal parallel rows, and the sliding arm abutting against the face *c* and carrying members in alignment with each of said rows. 3rd. A computing caliper comprising a tabulated shank having a fixed arm at one end thereof, and a sliding arm sleeved thereon, and an arm having a scaled shank adjustably secured to said fixed arm for the purpose described. 4th. A computing caliper comprising a shank, having arranged longitudinally and side by side thereon, a progressive series of diminished scales, formed by dividing a given unit by different numbers, a fixed caliper arm at one end of said shank, a sliding arm on said shank, a number opposite each scale on the shank corresponding to the number used in its formation, and an arm adjustably secured to said fixed arm having a scaled shank indicating progressively the difference between the diameter and one-half the circumference of a circle. 5th. A computing caliper comprising a tabulated shank, a sliding arm sleeved thereon and an arm or stop secured at one end of the shank for the purpose described.

No. 56,411. File Grinding Machine. (Machine à aiguiser les scies.)

James Turner, Paterson, New Jersey, U.S.A., 25th June, 1897; 6 years. (Filed 12th April, 1897.)

Claim.—1st. The combination in a grinding machine of a grinding wheel, a carriage arranged tangentially opposite said wheel, means for reciprocating the carriage, a series of rocking beds supported by the carriage and adapted to hold file blanks, and means for automatically rocking said beds upon their longitudinal axes, substantially as described. 2nd. The combination with the reciprocating carriage and grinder of a grinding machine, of a series of rocking beds each provided with an arm, a link connected with all of said arms, and means for automatically reciprocating the link, substantially as set forth. 3rd. The combination with the carriage, of a rocking bed having a curved face *x* and means of securing a file blank upon said face, substantially as set forth. 4th. In a file

grinding machine, the combination with a reciprocating bed having a curved face with bearings at its ends and yielding bearings inter-

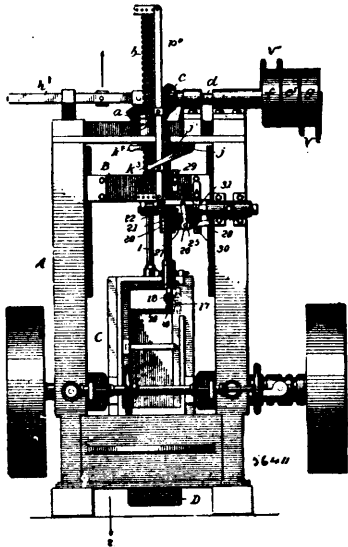

mediate the ends of said bed, substantially as described. 5th. The combination of the rocking bed F having a recess at one end to receive the tang of a file blank, and a sliding sleeve 10 for securing the point of the blank, substantially as set forth. 6th. The combination with a reciprocating carriage, rocking beds carried thereby, a link having a slotted arm 16, a shaft moving with the carriage and provided with a crank pin 17 entering the slot of said arm, and means for rotating the shaft, substantially as set forth. 7th. The combination with the reciprocating carriage, its rocking bed, and shaft 19, of a ratchet wheel through which the shaft passes, a bracket supporting the said ratchet wheel, an arm carrying a pawl engaging said wheel, a rock shaft provided with arms one of which is connected with the shaft, and studs or pins upon the support for the carriage C arranged to make contact with the arms of the rock shaft, substantially as and for the purpose set forth. 8th. The combination with a reciprocating carriage and cross bar, of the rocking beds and shaft 19 for operating the same, a bracket G carried by the frame of the machine and supporting a ratchet wheel through which the shaft 19 extends, a rock shaft supported by the bracket and provided with arms, one of which is connected with an arm carrying a pawl engaging the ratchet wheel, and adjustable pins 29, 30, upon the cross bar B, substantially as described.

No. 56,412. Organ. (Orgue.)

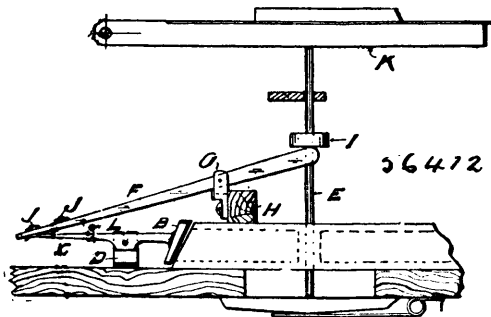

Samuel Howard, Manchester, England, 25th June, 1897; 6 years. (Filed 12th April, 1897.)

Claim.—1st. In American organs and like musical instruments operating on the exhaust principle, the application of a separate mute to each cavity of the reed box or cavity board representing the treble or bass, in combination with levers which are each acted upon by a pallet plunger of the reed box, and which in turn act permissively upon the mute of the next higher or lower note and allow such mute to close its cavity, substantially as and for the purposes set forth. 2nd. In American organs and like musical instruments operating on the exhaust principle, the combination of pallet plungers E, collars I, levers F, fingers J, brackets G, rail H, mutes B, carried by stems C, all mounted and operating as and for the purposes set forth. 3rd. In American organs and like musical instruments operating on the exhaust principle, and containing four or more sets of reeds, the combination of levers F, operating per-

missively upon one, two or more mute stems, as set forth. 4th. In American organs and like musical instruments operating on the exhaust principle, the combination of the foregoing arrangement of mutes, levers and stems with a rod or rail L, operated by a suitable stop, for the purpose described. 5th. In American organs and like musical instruments operating on the exhaust principle, the combination of mutes, levers and stems with rods or rails M, N and O, operated by suitable stop or stops, for the purposes described and illustrated on the accompanying drawings.

No. 56,413. Inkstand. (Encrier.)

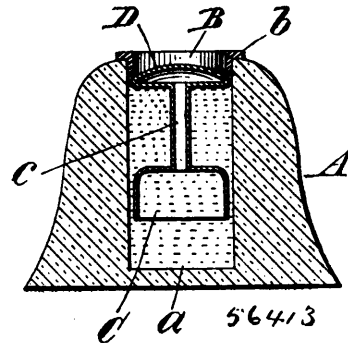

Lincoln Ninde Thomas, Madisonville, Ohio, U.S.A., 25th June, 1897; 6 years. (Filed 12th April, 1897.)

Claim.—1st. In an automatic inkstand, the combination of a body or bottle having a deep, vertical well, a ring or internal rim in the upper orifice of said well, a buoyant body or float submerged in the fluid-contents of said well and having a central, upright arm or stem surmounted by a valve head or cap, the latter bearing in intimate contact with the lower edge of the said ring or rim by the constant, upward, vertical pressure of the said fluid-contents resultant from the displacement-action caused by the submerging of said float, substantially as herein set forth. 2nd. In an automatic inkstand, a buoyant body or float composed of a float-proper having a central, upright arm or stem, and a convex valve head or cap surmounting said stem, substantially as herein set forth. 3rd. In an automatic-inkstand, a buoyant body or float composed of a float-proper C, a central, upright arm or stem c, and a convex cap or valve-head D, the whole buoyant body being made integral and hollow, substantially as herein set forth. 4th. In an automatic inkstand, a buoyant body or float composed of a solid float-proper, a central, upright arm or stem attached to said float-proper, and a valve cap or head surmounting said stem, the latter having an auxiliary passage-way therein for the upward passage of the ink therethrough, substantially as herein set forth.

No. 56,414. Meat Skewer. (Brochette à viande.)

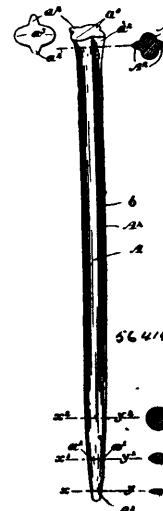

Walter Scott Shipe, Toronto, Ontario, Canada, 25th June, 1897; 6 years. (Filed 13th April, 1897.)

Claim.—1st. A skewer comprising a body portion with broadened point having double knife edge and knife edge tip, as and for the

purpose specified. 2nd. A skewer comprising the body portion with broadened point having double knife edge sides and knife edge tip and a flaring enlarged head, as and for the purpose specified. 3rd. A skewer comprising the body portion with broadened point having double knife edge sides and knife edge tip and longitudinal ribs having knife edges, as and for the purpose specified. 4th. A skewer comprising the body portion with broadened point having double knife edge sides and knife edge tip, longitudinal ribs having knife edges and flaring rounded head ends for the ribs, as and for the purpose specified. 5th. A skewer comprising the body portion with broadened point having double knife edge sides and knife edge tip, longitudinal ribs having knife edges, and flaring head ends in the body portion between the ribs, as and for the purpose specified. 6th. A skewer comprising the body portion with broadened point having double knife edge sides and knife edge tip, longitudinal ribs having knife edges, flaring rounded head ends for the ribs, and flaring head ends in the body portion between the ribs, as and for the purpose specified. 7th. A skewer comprising a body portion and longitudinal ribs having knife edges, as and for the purpose specified. 8th. A skewer comprising the body portion with broadened point having double knife edge and an outwardly flaring winged head, as and for the purpose specified. 8th. A skewer comprising the body portion with broadened point having double knife edge sides and knife edge tip, the breadth of the point having a gradual taper until it reaches the circular portion of the body and the thickness of the point between the knife edges also having a gradual taper until it reaches the circular portion of the body, as and for the purpose specified.

No. 56,415. Machine for Digging Potatoes.

(Machine pour arracher les patates.)

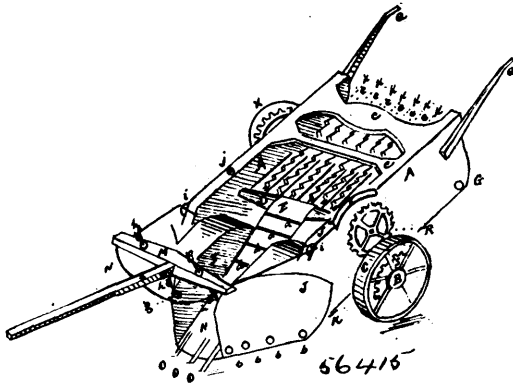

Gilbert Trambly and Martha Victoria Clay, both of Amherstburg, Ontario, Canada, 25th June, 1897; 6 years. (Filed 21st April, 1897.)

Claim.—The feeder H, of which the landsides T, T, the steel guides O, O, O, and the gauge rods f, f, form a part, substantially as and for the purpose hereinbefore set forth, and in combination with the separator, which consists of the separator bar P, of which the separator rods k, k, k, k, k, k, k, and the separators c, c, c, c, c, c, form a part, substantially as and for the purpose hereinbefore set forth.

No. 56,416. Chart for Cutting Trousers.

(Echelle pour découper les pantalons.)

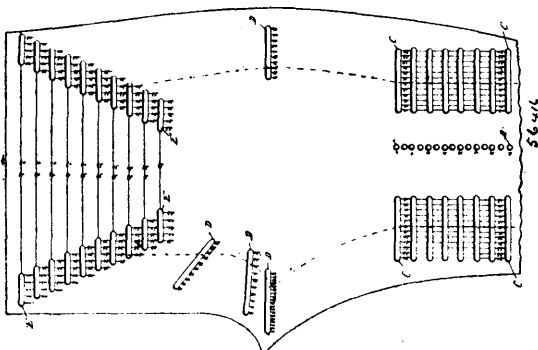

David Yrénée Bruneau, Kingsley Falls, Québec, Canada, 25 juin 1897; 6 ans. (Filé 12 avril, 1897.)

Résultat.—Une échelle pour tailler les pantalons constituée par une feuille de carton (ou autre substance convenable) dans laquelle

sont découpées des séries d'ouvertures oblongues B, C, D, E, graduées pour permettre de marquer sur le toffe, à l'aide des mesures ordinaires, un nombre suffisant de points du contour de chaque morceau d'un pantalon pour permettre de découper ce morceau, le tout tel que décrit, et pour les fins mentionnées.

No. 56,417. Knitters and Crocheters Ball and Spool Holders. (Boule, etc., pour tricoter et ouvrage au crochet.)

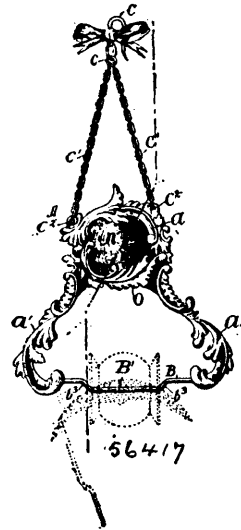

Annie Lovering Perot, Philadelphia, Pennsylvania, U.S.A., 26th June, 1897; 6 years. (Filed 15th April, 1897.)

Claim.—1st. A device of the class described, comprising an approximately U-shaped frame embodying a holding portion or members having a hinge connection at one end and a locking connection at the other end, and means for suspending the device in position, substantially as and for the purpose set forth. 2nd. A device of the class described, comprising an approximately U-shaped frame embodying a transverse top or cross piece carrying side pieces or arms and having a holding portion or members provided with a hinge connection at one end and a detachable locking connection at the other end, and means connected with said top or cross piece for suspending the device in position, substantially as and for the purpose set forth. 3rd. A device of the class described, comprising a suspending device adapted to be attached to the dress of the operator, a frame embodying a transverse top or cross-piece to which the suspending device is pivotally or loosely connected and depending side pieces or arms extending downwardly from the ends of said top or cross piece, and a bottom rod or bar having one end connected by a hinge joint with the lower end of one of the depending side pieces and its free end detachably connected with the opposite side piece, substantially as and for the purpose set forth. 4th. A device of the class described, comprising an approximately U-shaped frame embodying a transverse top or cross piece and depending side pieces or arms extending from the ends of the same, a bottom rod or bar having one end connected by a hinge joint with the lower end of one of the side pieces and its free end detachably connected with the opposite side piece, and suspending devices connected with the top or cross piece of the frame, substantially as and for the purpose set forth. 5th. A device of the class described, comprising a frame having a flat or smooth back face and its front face in relief and embodying a top or cross piece and depending side pieces or arms, a bottom rod or bar having one end connected by a hinge joint with the lower end of one of the side pieces and its free end detachably connected with the opposite side piece, and devices connected with the frame for suspending the same in position, substantially as and for the purpose set forth. 6th. A device of the class described, comprising an approximately U-shaped frame embodying depending side pieces or arms, and means for suspending the same in position, in combination with a rod or bar having a central bend forming end shoulders or angles and having one end connected by a hinge joint with the lower end of one of the side pieces and its free end detachably connected with the opposite side piece, substantially as and for the purpose set forth. 7th. A device of the class described, comprising an approximately U-shaped frame embodying a top or cross piece and depending side pieces or arms, a bottom rod or bar having one end connected by a hinge joint with the lower end of one of the side pieces and its free end detachably connected with the opposite side piece, a suspending hook or device adapted to be attached to the dress of the operator, and a chain or free connection connecting the suspending device with the top or cross piece of the frame, substantially as and for the purpose set forth. 8th. A device of the class described, comprising an approximately U-shaped frame embodying

a top or cross piece and depending side pieces or arms, a bottom rod or bar having a central bend forming end shoulders or angles and having one end connected by a hinge joint with the lower end of one of the side pieces and its free end detachably connected with the opposite side piece, a suspending hook or device adapted to be attached to the dress of the operator, and a chain or free connecting device connecting the suspending device with the top or cross-piece of the frame, substantially as and for the purpose set forth. 9th. A device of the class described, comprising the frame embodying the top and depending side pieces or arms, a bottom holding rod or bar having one end connected by a hinge joint with the lower end of one of the side pieces and its free end detachably connected with the opposite side piece, and a suspending device having a free pivotal or swivel connection with the top of the frame, substantially as and for the purpose set forth.

No. 56,418. Umbrella. (Parapluie.)

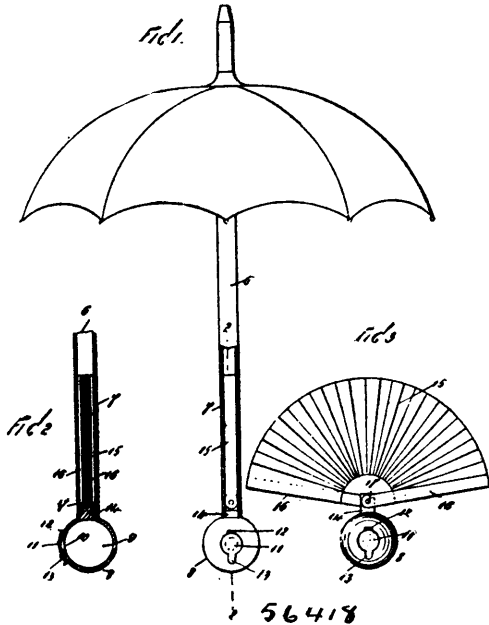

Katherine Eliza Landan, New York, State of New York, U.S.A., 26th June, 1897; 6 years. (Filed 15th April, 1897.)

Claim.—1st. A parasol or umbrella which is provided with a tubular stick, and a detachable handle, said detachable handle being provided with a shank which is adapted to be inserted into the end of the tubular stick, and a fan which is connected with the end of said shank and which is also adapted to be inserted into said tubular stick, substantially as shown and described. 2nd. A parasol or umbrella, the stick of which is provided with a tubular extension, and a handle which is provided at one side with a short shank which is adapted to be inserted into said tubular extension of the stick, said shank being provided with a fan which is adapted to be folded so as to be inserted into said tubular extension of the stick, substantially as shown and described. 3rd. A parasol or umbrella, the stick of which is provided with a tubular extension, and a handle which is provided at one side with a short shank which is adapted to be inserted into said tubular extension of the stick, said shank being provided with a fan which is adapted to be folded so as to be inserted into said tubular extension of the stick, said handle being hollow and provided at one side with an opening and a hinged cap or cover, substantially as shown and described.

No. 56,419. Pipe Coupling. (Joint de tuyau.)

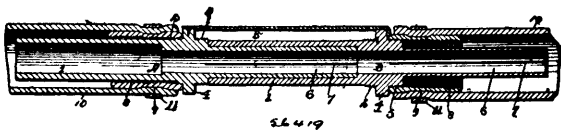

George Rodabush Thacker, Phillipsburg, Kansas, U.S.A., 26th June, 1897; 6 years. (Filed 20th April, 1897.)

Claim.—1st. In a pipe coupling, the combination of duplicate coupling-members each provided with a socket and an expansion-tube adapted to fit the socket of the other coupling-member, substantially as described. 2nd. In a pipe coupling, the combination with respective screw-threaded sleeves, of duplicate-coupling members each provided with a socket having external screw-threads

adapted to engage with the sleeve, and an expansion-tube adapted to fit the socket of the other coupling member, substantially as described. 3rd. In a pipe coupling, the combination with respective screw-threaded sleeves, of duplicate coupling-members each having a socket provided with an integral nut and respective screw-threaded sections thereon on opposite sides of said nut, said screw-threaded sections being adapted to engage with the sleeve, and an expansion-tube adapted to fit the socket of the coupling-member substantially as described.

No. 56,420. Egg Case Fastener.

(Attache pour boîtes à œufs)

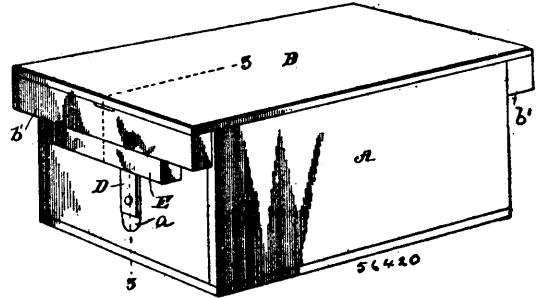

Warren Greene Davis, Winconsin, U.S.A., 26th June, 1897; 6 years. (Filed 8th May, 1897.)

Claim.—1st. A crate or case for the purpose described provided with guideways or grooves and a cover or lid provided with arms adapted to engage in the said guideways and fasten the cover to the crate or case, substantially as described. 2nd. A crate or case for the purposes described provided with guideways or grooves at its ends, the lower ends of said grooves or guideways being formed into shoulders, and a cover or lid having spring arms fastened thereto, and adapted to engage the shoulders referred to, for the purposes described. 3rd. A crate or case for the purposes described provided with guideways or grooves at each end, the upper portion whereof being made deeper than the lower portion, shoulders formed in the said lower portions of said guideways or grooves, a cover or lid having spring arms fastened thereto with studs at their lower ends, and cleats arranged transversely across the ends of the crate or case, substantially as described.

No. 56,421. Lock. (Serrure.)

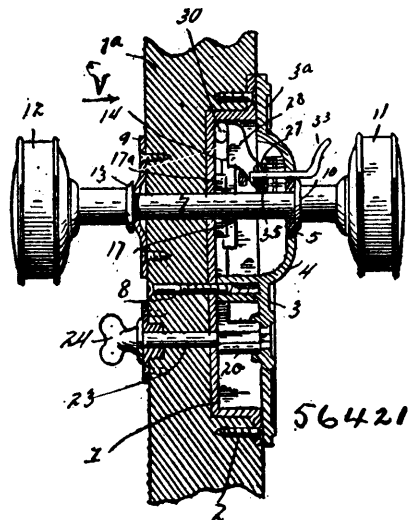

Edwin H. Boneberg and Jacob Elsaesser, both of Buffalo, New York, U.S.A., 26th June, 1897; 6 years. (Filed 2nd May, 1897.)

Claim.—1st. The combination in a lock provided with knobs for operating it, of a slotted locking bolt provided with projecting portions at the rear end of the bolt, means for keeping it forward with a yielding force, a locking bar on the knob-shaft adapted to operate against said projecting portions, a locking latch or foot-piece 28, and a cam bar 29 for lifting it out of engagement with the locking bar, for the purposes described. 2nd. The combination in a lock provided with knobs for operating it, of a slotted locking bolt provided with projecting portions at the rear end of the bolt, means for keeping it forward with a yielding force, a locking bar on the knob

shaft adapted to operate against said projecting portions, a locking-catch for lifting it out of engagement with the locking-bar, and a key for forming and breaking an electric circuit with an electric bell, for the purposes described. 3rd. The combination in a lock, of the slotted bolt through which the knob-shaft passes, means for keeping the bolt forward with a yielding force, a notch in the under side of the bolt, a main locking pivoted pawl adapted to engage with the notch and lock said bolt, a notch in the back of the main locking-pawl, a supplementary pawl adapted to be brought into engagement with the notch in the main locking-pawl and thereby lock it, and means on the inner side of the lock for operating the supplementary pawl, for the purpose described.

No. 56,422. Shoe Scraper. (Grattoir à chaussures.)

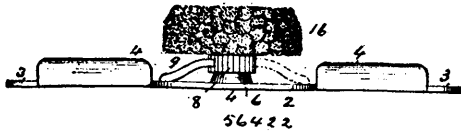

Fred Trumpler, Hoople, North Dakota, U.S.A., 26th June, 1897; 6 years. (Filed 17th May, 1897.)

Claim.—1st. A shoe scraper, comprising a plate having brush and scraper members disposed one at each side of the brush, as set forth. 2nd. A shoe scraper, comprising a base member having a flat central portion, having a vertical pintle, and a vertical scraper member at each end of the flat portion, and a brush held to rotate on the said pintle to engage the sides of the shoe as specified. 3rd. A shoe scraper, comprising a casting having a central flat portion, and apertured flat ends, and vertical scraper members between the central and the end portions, the flat portion having a pintle, a spur-wheel held thereon, a detent for engaging such wheel and a brush, consisting of a hub held to rotate with the spur-wheel in one direction, substantially as shown and described. 4th. A shoe scraper, consisting of a metal body having a central flat portion and apertured flat ends, and vertical scraper portions intermediate the ends, and the flat portion, the central portion having a pintle, a spur-wheel held therein having projections on its upper face, a rotary brush consisting of a body having brushes, arranged to form a conical upper portion, said body having sockets to receive the projections on the spur-wheel and a detent for holding the spur and brush from revolving one way as specified. 5th. The combination with a scraper having a pair of separated scraper portions, of a brush held to rotate between such scraper portions, means for holding it from rotation as the foot is drawn back to scrape the shoe, said brush having its upper end made conical as set forth.

No. 56,423. Bed. (Lit.)

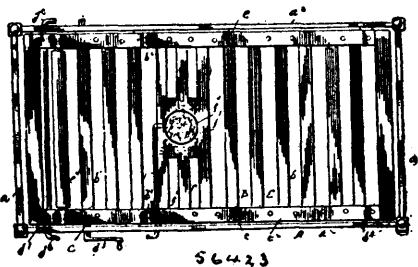

Isaac Laurin, Rhinelander, Wisconsin, U.S.A., 26th June, 1897; 6 years. (Filed 19th May, 1897.)

Claim.—1st. The herein-described improved bed, comprising a bedstead, a bed-frame secured therein and having a pivoted section, curved arms secured to said pivoted section, and provided with teeth in their front edges and notches in their rear edges, a shaft rotatably mounted in said bedstead and having pinions mounted thereon and adapted to engage the teeth of said arms, spring-arms adapted to engage said notches, and a shaft adapted to disengage said spring-arms from said notches, substantially as described. 2nd. The herein-described improved bed comprising a bedstead, a bed-frame secured therein, and having a pivoted section, curved arms secured to said pivoted section, and provided with teeth in their front edges and notches in their rear edges, a shaft rotatably mounted in said bedstead, and having pinions keyed thereon and adapted to engage the teeth of said arms, spring-arms adapted to engage said notches, and a rotatable rod or shaft having a crank-handle and angular portions adapted to disengage said spring-arms from said notches, substantially as set forth. 3rd. The herein described improved bed, comprising a bed-frame having a pivoted member, spring-slats secured to said bed-frame, one of which is provided with a central enlarged portion having a hole or opening,

a trap adapted to normally close said opening and having an arm or extension pivotally connected to said latter slat, and a rod or arm for normally holding said trap closed, substantially as and for the purpose set forth. 4th. The herein-described improved bed, comprising a bed-frame having a pivoted member, spring-slats having central bowed portions, and outer slotted ends secured to said bed-frame, one of which is provided with a central enlarged portion having a hole or opening, a ledge or support formed on the under side of said enlarged portion adjacent said opening, a trap pivotally connected to said slat, and adapted to normally close said opening, and a rod or arm the inner end of which is adapted to rest on said ledge or support and hold said trap in its normally closed position.

No. 56,424. Portable Suspended Crib. (Crèche portative.)

(Crèche portative.)

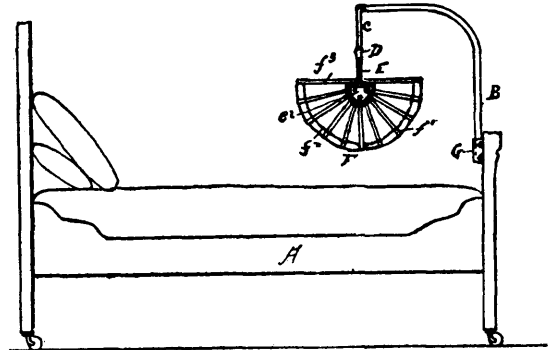

56424

William W. Ranney, Columbus, Ohio, U.S.A., 26th June, 1897; 6 years. (Filed 22nd May, 1897.)

Claim.—1st. The combination, with a pair of end blocks, of a basket formed of rods secured to said end blocks, a pair of hangers each having one end flattened out to form a plate, which is secured to its respective end block, and means for pivotally supporting the pair of hangers, substantially as described. 2nd. The combination, with a pair of end blocks having a series of holes in their edges, a basket formed of a series of rods whose ends are secured in the respective holes in the end blocks, and a pair of hangers having plates, each plate being secured to its respective end block, of a cross-piece to which the hangers are pivoted, one at each end, and means for supporting the cross-piece rotatably, substantially as described. 3rd. The combination with a rotatable crane, of a T on the end of the crane, a pair of basket-supporters fixed to the T and bent downward, a gooseneck secured to each support, each provided with a slot, a hanger pivoted in each slot, and a basket carried by the hangers, substantially as described. 4th. A socket for supporting a portable hammock, comprising a socket casting having a cylindrical hole to receive the crane, a bearing-surface at the bottom of said hole, and a series of flanged lugs provided with screw-holes, said casting having a flat portion on each side of a concave rear surface, in combination with a stirrup-bolt whose ends are arranged to enter the screw-holes of the lugs, substantially as described.

No. 56,425. Plough. (Charrue.)

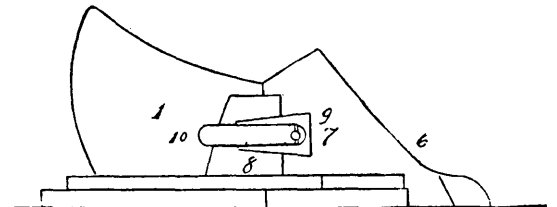

2 16 56425

Malray Mitchell Wroten, Mer Rouge, Louisiana, U.S.A., 26th June, 1897; 6 years. (Filed 22nd May, 1897.)

Claim.—1st. A plough, the point of which is provided with a dovetail recess and an inclined segmental eccentric face, substantially as shown and described. 2nd. A plough, the point of which is provided with a rectangular dovetail tongue 16, and a wedge-shaped dovetail tongue 3, provided with an integral stud 7, on which is mounted a pivoted clamping arm 8, in combination with a mould-board having an integral brace 5, having a wedge-shaped dovetail recess 4, and a shoe provided with a rectangular dovetail recess 15, substantially as and for the purpose set forth.

No. 56,426. Nut Lock. (Arrête-écrou.)

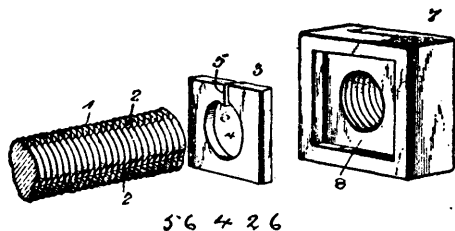

Richard Kidder Gregory, Greensboro, North Carolina, U.S.A., 26th June, 1897; 6 years. (Filed 22nd May, 1897.)

Claim.—A nut lock comprising the bolt 1, the threaded end of which is provided with a series of longitudinal ratchet shaped grooves 2, the rectangular washer 3, having a central circular orifice 4, radial slots 5, and projecting ratchet shaped tooth 6, formed integral with one of the edges of the washer which form the slot 5, and the nut 7 having its inner face provided with a rectangular recess 8, adapted to contain said washer 3, substantially as shown and described.

No. 56,427. Car Fender. (Défense de chars.)

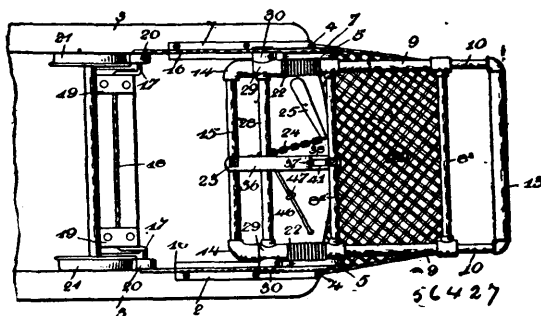

Samuel Colwell Bole, Leechberg, Pennsylvania, U.S.A., 26th June, 1897; 6 years. (Filed 22nd May, 1897.)

Claim.—1st. A combined fender and brake, comprising the guide plates 1 and 2, the pivoted straps 5-5, the rectangular frame 8, pivoted to the lower ends of said straps, the rods 10-10 mounted in said frame 8, the spiral springs 22-22 mounted on said rods, the cross rod 15 connecting the rear ends of the rods 10-10, and provided with the eye-bolt 23, the crank arm 25, connected to said eye-bolt by a chain 24, and mounted on a vertical shaft 26, provided with an operating wheel 27, the spring arm 36 fixed on the cross rod 15, and the arm 38 rigidly mounted on the cross rod 8¹ and formed with vertical slot 41, the bell crank lever 40 fulcrumed in said slot, and having a depending end 42, and a longer horizontal arm 43, a lever 46 fulcrumed in a bracket 47, and having its inner end pivoted to said arm 43 and its outer end connected to a vertical rod 48 extending through the front platform, substantially as shown and described. 2nd. A car fender and brake, comprising the rectangular frame 8 suspended from the front platform by the pivoted straps 5-5, the friction rollers 20-20 mounted on the arms 17 of the crank shaft 18, and the rods 16-16 connecting said arms 17 with the frame 8, substantially as and for the purpose set forth. 3rd. A combined brake and fender, comprising the rectangular frame 8, suspended from the car by the pivoted straps 5-5, the arm 38 rigidly fixed on the cross bar 8¹ of said frame, and formed with a wedge-shaped tooth 39 and a vertical slot 41, a bell crank lever 40 fulcrumed in said slot, said lever having a short depending end 42, and its horizontal arm 43 provided with a detent 44, a lever 46 pivoted to the outer end of said arm and provided with a vertical rod 48 extending upwardly through the car platform, in combination with the spring arm 36 fixed on the cross rod 15, and the arm 31 fixed on the cross rod 28, and having a wedge-shaped tongue 32 and an integral finger 33 having a locking pawl 34, substantially as shown and described.

No. 56,428. Wire Stretcher. (Tendeur de fil de fer.)

Elvin Stephen Barrows, North Clarendon, Vermont, U.S.A., 26th June, 1897; 6 years. (Filed 22nd May, 1897.)

Claim.—1st. A bar provided with a swivelled claw knee, substantially as and for the purpose set forth. 2nd. A bar provided with a claw knee pivoted thereto by a bolt, substantially as and for the purpose set forth. 3rd. A bar provided with a pointed end, and having the claw knee pivoted thereto by a bolt, substantially as and for the purpose set forth. 4th. A bar provided with a swivelled knee, having a V-shaped slot, substantially as and for the purpose set forth. 5th. The combination with the bar, of the claw knee pivoted to a sleeve detachably secured to said bar by a set screw,

substantially as and for the purpose set forth. 6th. A bar provided with a pointed end, and having a claw knee pivoted thereto, the

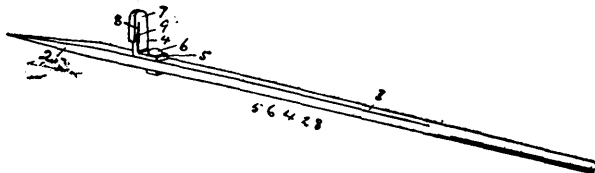

base of the V-shaped slot of which is directed towards said bar, substantially as shown and described.

No. 56,429. Scarf Holder. (Porte-écharpe.)

Fig. 1.

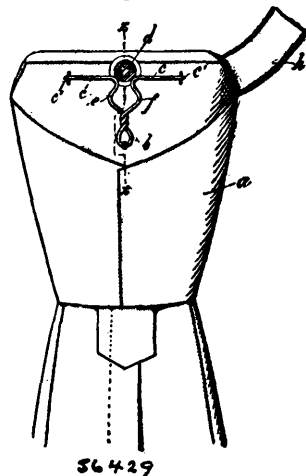

Herman Goldbeck, Schwenkendorf Estate, Mohrungen, Prussia, 28th June, 1897; 6 years. (Filed 10th May, 1897.)

Claim.—1st. The improved cravat holder, consisting of the clip e, f, formed of the twisted wire, which is secured with arms for projecting at right angles in such a manner to the cravat that the said arms can be pushed sideways, whilst the lower part of the fastener b, twisted into the form of a loop, is firmly secured to the cravat, the clip e, f, grasping the neck of the shirt stud d by means of the spring, and thus securing the cravat without side bands, constructed and arranged substantially as hereinbefore described. 2nd. A modification of the cravat holder, set forth in claim 1, in which the spring action of the clip is increased by means of a spiral spring g connecting the arms e, f, thereof, constructed and arranged, substantially as hereinbefore described. 3rd. The improved clip for cravats, constructed with reference to the accompanying drawing, constructed and arranged substantially as hereinbefore described.

No. 56,430. Bottle Sealing Device. (Appareil à sceller les bouteilles.)

(Appareil à sceller les bouteilles.)

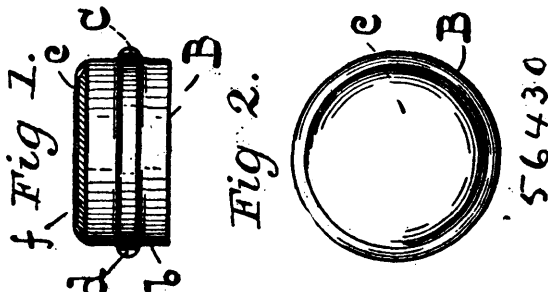

Lewis Kalling, Baltimore, Maryland, U.S.A., 28th June, 1897; 6 years. (Filed 25th May, 1897.)

Claim.—In combination with a bottle head, a cap to fit over the same, having a hollow bead in its side or lateral wall and a gasket situated in the hollow bead, or between the lateral wall of the cap and the exterior surface of the bottle head, the said head being crushed or flattened onto the gasket so as to distort its original shape and thereby form a tight joint, substantially as specified.

No. 56,431. Whiffletree Iron. (Fer de palonnier.)

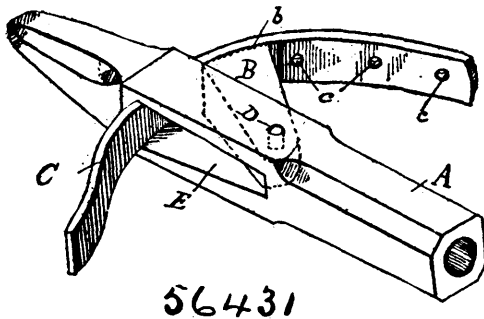

John W. Jones, Onondaga, Michigan, U.S.A., 28th June, 1897 ; 6 years. (Filed 25th May, 1897.)

Claim.—The combination with the main whiffletree iron having a slot to receive a pivoted catch and a seat in the end of the slot, of the cam-shaped catch pivoted in the slot and carrying on its outer face a pin adapted to be supported in the seat in the slot.

No. 56,432. Cotton Chopper. (Machine à coton.)

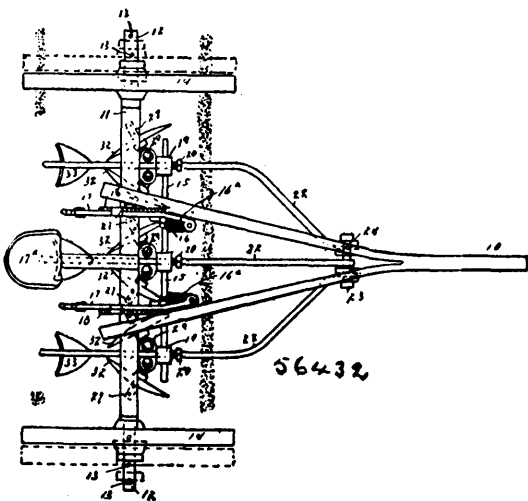

John Richman Miller, Bend, Texas, U.S.A., 28th June, 1897 ; 6 years. (Filed 25th May, 1897.)

Claim.—1st. In a cotton chopper, the combination of the hangers comprising two parallel bars, concave rotary disks pivoted thereto on each side of the centre, with a plough beam passing between said bars and guided thereby, and a shovel upon its rear end occupying the space between said disks, substantially as described. 2nd. In a support for rotary disks, the combination of a depending arm having a horizontal head extending across the line of motion, and provided with vertical holes therethrough near each end and locking pin-holes adjacent thereto, with arms having journals at right angles to each other, one of said journals passing through one of the holes in the head, a notched disk fixed to its upper end, a pin adapted to engage one of said notches and a pin-hole in the head, and a rotary disk journaled upon the horizontal journals, substantially as described. 3rd. In a support for rotary disks, the combination of a depending arm having a horizontal head upon its lower end, and extending across the line of motion and provided with a vertical hole therethrough near each end, and locking pin-holes adjacent thereto, with bars having right angled journals pivoted in said holes, notched disks fixed to their upper ends, locking-pins engaging said notches and the pin holes, disks fitting the horizontal journals and means for adjusting the disks consisting of holes through the journal and pins therefor, substantially as described. 4th. In a cotton-chopping machine, a hanger, angular spindles adjustable in the said hanger, a locking device for the spindles, and disk choppers adjustably mounted on the spindles, as and for the purposes specified.

No. 56,433. Windmill. (Moulin à vent.)

Anton Zwiebel, Burlington, Wisconsin, U.S.A., 28th June, 1897 ; 6 years. (Filed 25th May, 1897.)

Claim.—1st. The combination in a windmill of the class described having a segmental shield at one side of the windward side of the

wind-wheel, of a second shield normally disposed at the lee side of the first-mentioned shield, the shields adapted to move one past the

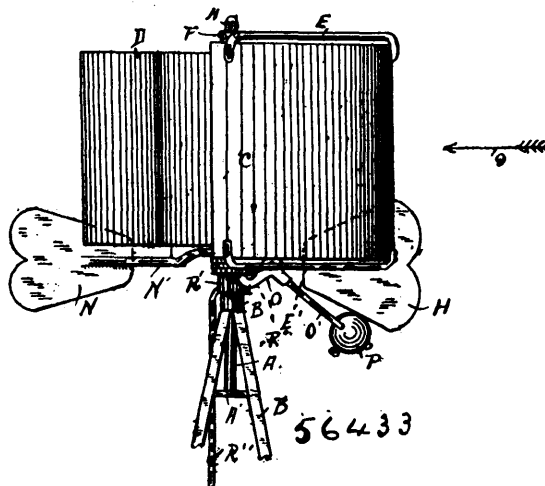

other from the normal position and be maintained on the windward side of the wind-wheel by the action of the wind on vanes connected to the same, and means for returning the shields to the normal position independent of the action of the wind, substantially as shown and described. 2nd. The combination in a windmill of the class described, having a shield maintained at one side of the windward side of the wind-wheel by the action of the wind on a vane connected therewith, of a second shield normally at the lee side of the first-mentioned shield, the second shield moved out from the lee side of the first shield by the action of the wind upon a vane connected therewith, and means connected between the two shields for presenting a yielding resistance to such movement and for returning the shields to the normal position substantially as stated. 3rd. In a windmill of the class described, a two-part shield at one side of the windward side of the wind-wheel, one of the shields normally at the lee side of the other, each side provided with a vane which by the action of the wind opens the shields, a weighted lever mounted on the support of one of the shields, the lever having an arm connected to the support of the other shield, and adapted by the gravity of the weight to yieldingly hold the shields in the closed position against the pressure of the wind against the vanes, substantially as described.

No. 56,434. Window. (Fenêtre.)

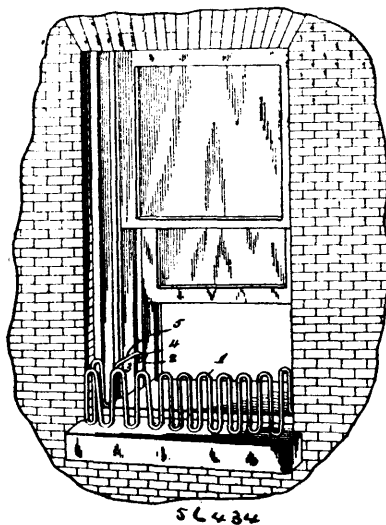

John F. Fullagar, Kearney, New Jersey, U.S.A., 28th June, 1897 ; 6 years. (Filed 25th May, 1897.)

Claim.—A guard for windows consisting of a single piece of metal formed into a series of convolutions, the end convolutions terminating short of the other convolutions, the extremities of the end convolutions being bent at right angles and extending rearward, and means for detachably securing the guard to the window, substantially as shown and described.

No. 56,435. Motor Vehicle. (Voiture à moteur.)

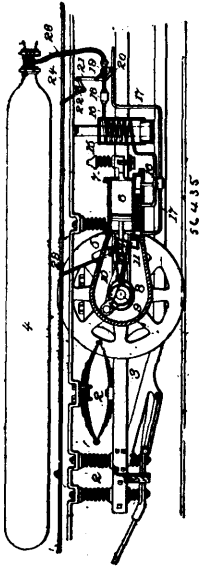

Walter Harris Knight, New Brighton, New York, U.S.A., 28th June, 1897; 6 years. (Filed 25th May, 1897.)

Claim.—1st. In a motor vehicle, the combination of a truck or running gear, a vehicle body spring-mounted thereon, fluid pressure reservoirs carried by the vehicle body, a motor or motors carried by the truck or running gear and comprising an engine or engines, controlling handles or levers on the vehicle body and flexible connection therefrom to the controlling valves of said engine or engines, substantially as set forth. 2nd. In a motor vehicle, the combination of a truck or running gear, a vehicle body spring-mounted thereon, fluid pressure bottles or reservoirs carried by the vehicle body, a controlling handle or lever on the vehicle body, a fluid pressure motor carried by the truck or running gear and flexible connections between said fluid pressure bottles or reservoirs and said motor, and between said controlling handle or lever and the controlling valves of said motor, substantially as set forth. 3rd. In a motor vehicle, the combination of a truck or running gear, a vehicle body spring-mounted thereon, fluid pressure bottles or reservoirs carried by said vehicle body, a motor carried by said truck or running gear, and comprising an engine and a heating device, and flexible piping from said fluid pressure bottles or reservoirs to said motor, substantially as set forth. 4th. In a motor vehicle, the combination of a truck or running gear, a vehicle body mounted thereon, fluid pressure reservoir, a motor adapted to derive therefrom operating fluid under pressure, and having a casing completely covering its operating parts, and controlling mechanism having operating handle or lever on the vehicle body and entering said casing by airtight connection, substantially as and for the purposes set forth. 5th. In a motor vehicle, the combination of a fluid motor, a casing enclosing the moving parts of the motor and protecting the same from dust, a controlling device inside the casing, and a controlling device outside the casing having dust-tight communication with the controlling device inside the casing. 6th. In a motor street car, the combination of a fluid motor for propelling the car, a casing enclosing the moving parts of the motor and protecting same from ingress of dust and egress of oil, controlling mechanism inside the casing, and controlling mechanism on the car platform having dust-proof communication with the controlling mechanism in the casing. 7th. In a motor vehicle, the combination of a truck or running gear, a vehicle body mounted thereon, a fluid pressure reservoir and motor carried by said vehicle, said motor having high and low pressure throttle valves and a distributing valve, and a single controlling device connected to and adapted to operate all of said valves, simultaneously. 8th. In a motor vehicle, the combination of a truck or running gear, a vehicle body mounted thereon, a fluid pressure reservoir and motor carried by said vehicle, said motor having high and low pressure throttle-valves, a distributing valve and cylinder pressure relief valve, and a single controlling device connected to and adapted to operate all of said valves simultaneously. 9th. In a motor vehicle, the combination of the truck or running gear, and a motor mounted thereon, and having a cylinder, and a casing surrounding the operating parts, the cylinder exhaust passage connected to said casing, and said casing having a restricted and muffled escape passage adapted to retain a low pressure and the lubricant, and to exclude dust, substantially as set forth. 10th. In combination, the vehicle having running gear and a vehicle body mounted upon springs upon the running gear, a propelling motor operated by fluid pressure and mounted upon the running gear, a casing enclosing

the moving parts of said motor and protecting the same from dust, controlling apparatus outside said casing making dust-tight communication with controlling apparatus inside the casing, and a controller on the vehicle body connected by flexible or jointed connections with the said controlling apparatus outside the casing. 11th. The combination, in an air motor, of valves for opening a connection between the ends of the cylinder, and mechanism for operating said valves at will. 12th. The combination, in an air motor, of valves for opening a connection between the two ends of the cylinder, a controlling device for operating the throttle of the motor and connection, whereby the said controlling device opens the valve or valves in the connection between the ends of the cylinder so as to relieve the motor of compression occurring at the ends of the stroke when the motor is not doing work. 13th. A compound air motor having high pressure and low pressure cylinder and compression relief valves on the low pressure cylinder.

No. 56,436. Motor for Motor Vehicles.

(Moteur pour voitures à moteur.)

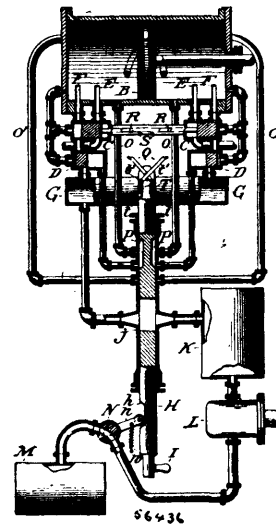

Walter Harris Knight, New Brighton, New York, U.S.A., 28th June, 1897; 6 years. (Filed 25th May, 1897.)

Claim.—1st. A controller for fluid pressure engines operated from a low pressure reservoir supplied from a reservoir of high pressure, combining a low pressure throttle valve for admitting pressure to the engine from the low pressure reservoir or supply, and a stop valve or high pressure throttle for opening the passage from the high pressure to the low pressure reservoir, both valves being operated by the same handle. 2nd. A controller for fluid pressure engines, combining a throttle valve for admitting pressure to the engine from a low pressure reservoir, and a valve for controlling the cut-offs, both operated by the same handle. 3rd. A controller for fluid pressure engines, combining a throttle valve for the engine, and cut-off valves, minimum cut-off being in operation with the first opening of the throttle, and the maximum cut-off when the throttle is fully opened. 4th. A fluid pressure engine combined with a high pressure reservoir, a low pressure reservoir, a reducing valve for regulating the supply from the high pressure to the low pressure, a stop valve for shutting off the high pressure, and a controlling mechanism for operating the throttle valve of the engine and the high pressure stop valve simultaneously. 5th. A fluid pressure engine combined with a high pressure reservoir, a low pressure reservoir, a reducing valve for regulating the supply from the high pressure to the low pressure, a high pressure throttle or stop valve for shutting off the high pressure, suitable reversing mechanism, and a controlling mechanism adapted to simultaneously operate the throttle valve, the high pressure throttle or stop valve and the reversing mechanism. 6th. A controller for fluid pressure engines, combining a throttle valve, a main valve and separate cut-off valves, means for controlling the cut-off valves, and means for reversing the engine, all operated by one handle. 7th. A controller for fluid pressure engines, in which the valves are operated by fluid pressure, the combination of a throttle valve, cut-off controlling valve, and reversing mechanism for throwing the main valve in position to reverse the engine, all controlled by one handle. 8th. A controller for fluid pressure engines, combining a stop valve for shutting off passage between high pressure and low pressure reservoir, a throttle valve, a cut-off controlling valve, and a main valve reversing mechanism. 9th. The combination of the handle I, controlling valve H, comprising throttle valve J, cut-off controlling valve P, a valve reversing mechanism and stop valve N.

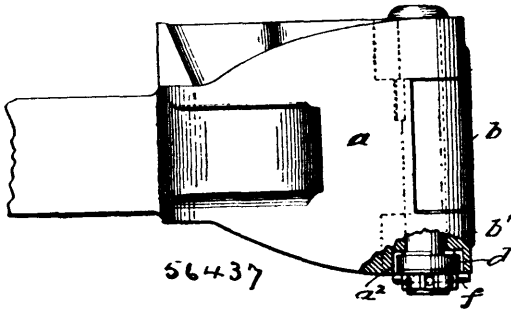
No. 56,437. Car Coupler. (Attelage de chars.)

Stephen Jones Meeker, Newark, New Jersey, U.S.A.; 28th June, 1897; 6 years. (Filed 25th May, 1897.)

Claim.—1st. In a car-coupler, the combination with the draw-head having a pocket or recess in its under side, of the swinging hook or knuckle having a connecting arm or pin projecting through said pocket provided with a plate or disc removably secured thereon in a position about flush with the under surface of the draw-head, whereby an enclosed accessible pocket is formed within the surface line of the draw-head, the said plate being provided with a flange or projection on its upper surface, and a coiled spring removably supported within said pocket in the draw-head and on its covering plate, having connection at its opposite ends with the said flange or projection and with the draw-head respectively, substantially as described and for the purpose set forth. 2nd. In a car-coupler, the combination with the draw-head and the swinging hook or knuckle having a connecting arm or pin, of a plate or disc supported on said pin, provided with a flange or projection on its upper surface, and a coiled spring supported on said plate having one end connected with the flange or projection thereon, and its opposite end connected with the draw-head, substantially as and for the purpose set forth. 3rd. In a car-coupler, the combination with the draw-head and the swinging hook or knuckle having a connecting arm or pin, of a plate or disc supported on said pin, provided with flanges or projections on its upper surface, and a flat coiled spring supported on said plate having one end constructed for detachable and adjustable connection with the flanges or projections thereon, and its opposite end connected with the draw-head, substantially as described and for the purpose set forth. 4th. In a car-coupler, the combination with the draw-head and the swinging hook or knuckle having a connecting arm or pin, of a plate supported on said arm, provided with a flange or collar on its under side having an opening therein whereby the plate may be removably secured on its supporting arm by a pin or its equivalent, and a flat coiled spring supported on said plate having one end connected therewith, and its opposite end connected with the draw-head, substantially as described and for the purpose set forth. 5th. In a car-coupler, the combination with the draw-head and the swinging hook or knuckle having a connecting arm or pin, of a plate supported on said arm, provided with a flange or collar on its under side having a series of oppositely located openings therein whereby the plate may be removably and adjustably secured on its supporting arm by a pin or its equivalent, and a coiled spring supported on said plate with one end connected therewith and its opposite end connected with the draw-head, substantially as described and for the purpose set forth. 6th. A knuckle opening attachment for car-couplers, consisting of a plate or disc having means for detachable connection with an arm or pin of a coupler knuckle, and with means for supporting and retaining a coiled spring thereon, a coiled spring supported upon said plate or disc with end connected therewith, and a device having a removable connection with the outer end of said spring and with the said plate or disc, substantially as described and for the purpose set forth. 7th. In a car-coupler, the combination with the draw-head and the swinging hook or knuckle having a connecting arm or pin, of a plate supported on said arm constructed for detachable and adjustable connection therewith and provided with a flange or collar on its under side having ribs or projections on its outer surface, and a coiled spring supported on said plate having one end connected therewith, and its opposite end connected with the draw-head, substantially as described and for the purpose set forth.

No. 56,438. Car Coupler. (Attelage de chars.)

Stephen Jones Meeker, Newark, and William Peniston Deacon, East Orange, both in New Jersey, U.S.A.; 28th June, 1897; 6 years. (Filed 25th May, 1897.)

Claim.—1st. In a car-coupler, the combination with the draw-head, of a horizontally moving coupling hook or knuckle pivotally supported by said draw-head, provided with a part or extension on its inner arm which moves beneath the locking device or pin when the latter is raised from locking engagement with the knuckle, and is of sufficient length to support said pin thereon when the knuckle is in its open position, which said pin supporting part or extension

is formed with an inclined surface extending throughout its entire length and in the direction of its movement, which incline descends

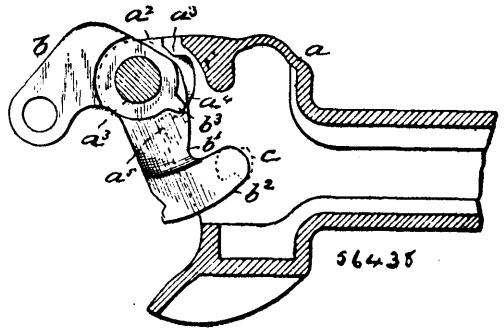

from the forward to the rear edge of said pin supporting part, substantially as described and for the purpose set forth. 2nd. In a car-coupler, the combination with the draw-head provided with two ears or bearings arranged one above the other, and with a horizontally arranged groove in its vertical wall between said bearings, which groove terminates at one end thereof in a stop-wall or projection, of a coupling hook pivotally supported between said bearings, and provided with a projection on its vertical wall extending into said groove in the draw-head, substantially as described and set forth.

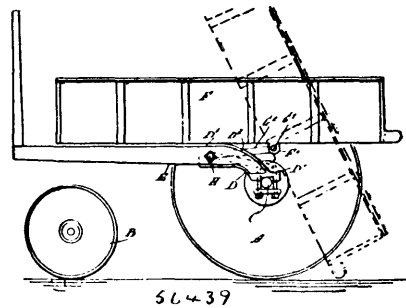
No. 56,439. Dumping Wagon. (Wagon a bascule.)

Thomas Hill, Jersey City, New Jersey, U.S.A.; 28th June, 1897; 6 years. (Filed 25th May, 1897.)

Claim.—1st. A dumping wagon, comprising a body portion provided with a plate having eyes, side rails curved rearward and downward and terminating in seats in which the eyes on the body portion are designed to engage, a rod having its ends pivoted in the eyes and arms extended from said rod to a pivotal engagement with the side rails, substantially as specified. 2nd. A dumping wagon comprising a body portion having eyes secured thereto, a rod extended transversely of the body portion and having its end engaged in the eyes, rearwardly and downwardly curved sleeves on the side rails of the wagon terminating in seats in which the eyes may engage and turn, arms extended forward from said transverse rod, and a rod to which the arms are pivoted, the said rod passing through the side bars and through the sleeves and serving to hold said sleeves in place, substantially as specified. 3rd. A dumping wagon, comprising side bars, curved sleeves terminating in upwardly-curved seats, on the rear ends of said side bars, clips engaging the axle of the wagon, springs supported on said clips and on which the sleeves are mounted, a body portion having eyes adapted to turn in the seats on the sleeves, and the arms connecting the body portion to the side bars, substantially as specified. 4th. A wagon of the class described, having a transverse bar having bearings in eyes on the wagon body, and having integral forwardly-extended arms adapted for pivotal connection with the side bars of the wagon, substantially as specified. 5th. In a dumping wagon, the combination with the side bars thereof, of metal box-like sleeves engaging over the rear ends of the side-bars and having the curved portion terminating in curved seats forming bearings for the dumping movement of the body, substantially as specified.

No. 56,440. Bottle. (Bouteille.)

Napoléon Guillaume Pierre Fortin, West Medway, Mass., U.S.A.; 28th June, 1897; 6 years. (Filed 26th May, 1897.)

Claim.—1st. A bottle or other vessel provided with a neck, and means for sealing or closing the same, consisting of a disk or plate as 9, which is provided at one side with a port or passage, a removable plug which is adapted to be inserted into the neck above

said disk or plate, a supplemental disk or plate which is adapted to be forced into the neck above said plug, said plug and said disk or

and are provided with a wheel which is mounted between the same, and by which they are supported, said frame being also provided

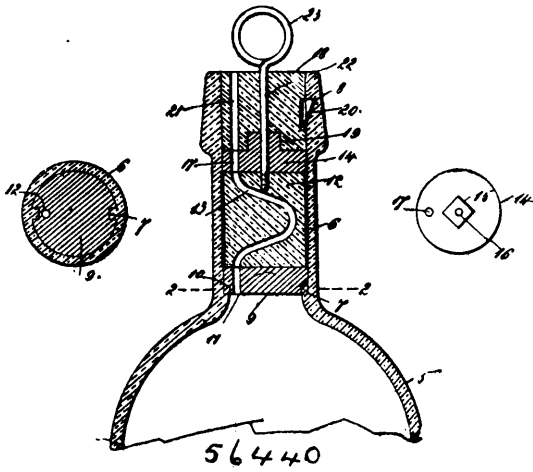
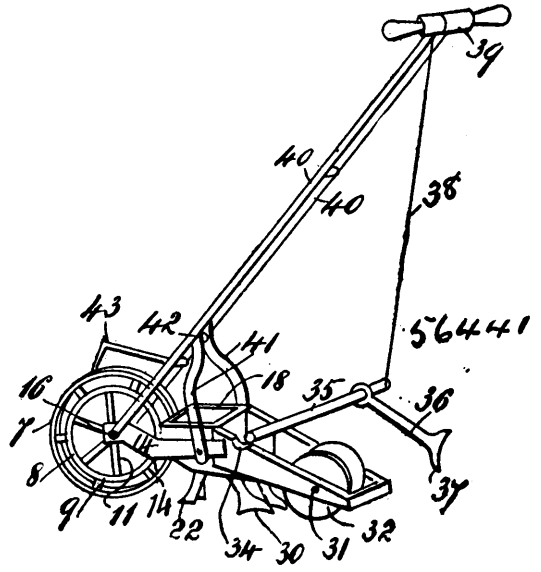

plate being provided with ports or passages which are adapted to register, and the port or passage in the plug being adapted to register with the port or passage in the disk or plate 9, and a supplemental plug which is adapted to be secured into the neck of the bottle above said supplemental disk or plate, and which is provided with a port or passage which is adapted to register with the port or passage in said disk or plate, substantially as shown and described. 2nd. A bottle or other vessel provided with a neck and means for sealing or closing the same, consisting of a disk or plate as 9, which is provided at one side with a port or passage, a revoluble plug which is adapted to be inserted into the neck above said disk or plate, a supplemental disk or plate which is adapted to be forced into the neck above said plug, said plug and said disk or plate being provided with ports or passages which are adapted to register, and the port or passage in the plug being adapted to register with the port or passage in the disk or plate 9, and a supplemental plug which is adapted to be secured into the neck of the bottle above said supplemental disk or plate, and which is provided with a port or passage which is adapted to register with the port or passage in said disk or plate, said supplemental plug and said supplemental disk or plate being adapted to be secured together so neither can turn in the neck, substantially as shown and described. 3rd. A bottle or other vessel provided with a neck, and means for sealing or closing the same, consisting of a disk or plate as 9, which is provided at one side with a port or passage, a revoluble plug which is adapted to be inserted into the neck above said disk or plate, a supplemental disk or plate which is adapted to be forced into the neck above said plug, said plug and said disk or plate being provided with ports or passages which are adapted to register, and the port or passage in the plug being adapted to register with the port or passage in the disk or plate 9, and a supplemental plug which is adapted to be secured into the neck of the bottle above said supplemental disk or plate and which is provided with a port or passage which is adapted to register with the port or passage in said disk or plate, said supplemental plug and said supplemental disk or plate being adapted to be secured together so that neither can turn in the neck, and a key for turning the revoluble plug which is passed through the supplemental plug and supplemental plate, substantially as shown and described.

No. 56,441. Cultivator. (Cultivateur.)

Edmund Piggott, Dresden, Ontario, Canada, 28th June, 1897; 6 years. (Filed 26th May, 1897.)

Claim.—1st. The herein described garden implement, consisting of a seed drill comprising a main wheel, a frame consisting of suitable side bars or parts, the forward ends of which are mounted on the shaft or axle of the main wheel, and the rear ends of which project downwardly and backwardly, and are provided with a wheel which is mounted between the same, and by which they are supported, said frame being also provided with a seed or grain box, in the bottom of which is an opening which communicates with a chute through which the seed or grain passes, and said frame being also provided rearwardly of said grain or seed box with two ploughs or shovels, one of which is located at each side of the frame, and which are adapted to cover the seed, said seed or grain box being also provided with a pivoted lever having an arm which is adapted to move back and forth over the opening in the bottom of said box, and said lever being adapted to be operated by the main wheel, substantially as shown and described. 2nd. The herein described garden implement, consisting of a seed drill comprising a main wheel, a frame consisting of suitable side bars or parts, the forward ends of which are mounted on the shaft or axle of the main wheel, and the rear ends of which project downwardly and backwardly,



with a seed or grain box, in the bottom of which is an opening which communicates with a chute through which the seed or grain passes, and said frame being also provided rearwardly of said grain or seed box with two ploughs or shovels, one of which is located at each side of the frame, and which are adapted to cover the seed, said seed or grain box being also provided with a pivoted lever having an arm which is adapted to move back and forth over the opening in the bottom of said box, and said lever being adapted to be operated by the main wheel, and said box being provided with means for regulating the size of the opening in the bottom thereof, substantially as shown and described. 3rd. The herein described garden implement, consisting of a seed drill comprising a main wheel, a frame consisting of suitable side bars or parts, the forward ends of which are mounted on the shaft or axle of the main wheel, and the rear ends of which project downwardly and backwardly, and are provided with a wheel which is mounted between the same, and by which they are supported, said frame being also provided with a seed or grain box, in the bottom of which is an opening which communicates with a chute through which the seed or grain passes, and said frame being also provided rearwardly of said grain or seed box with two ploughs or shovels, one of which is located at each side of the frame, and which are adapted to cover the seed, said seed or grain box being also provided with a pivoted lever having an arm which is adapted to move back and forth over the opening in the bottom of said box, and said lever being adapted to be operated by the main wheel, and said box being provided with means for regulating the size of the opening in the bottom thereof, and said frame being also provided with upwardly directed side bars which are connected with rods or bars, the lower ends of which are mounted on the shaft or axle of the main wheel, and which project upwardly and backwardly and are provided with a cross-head or handle bar, and means connected with the frame for marking out a succeeding line or furrow, substantially as shown and described. 4th. The herein described garden implement, consisting of a seed drill, comprising a main wheel, a frame consisting of suitable side bars or parts, the forward ends of which are mounted on the shaft or axle of the main wheel, and the rear ends of which project downwardly and backwardly, and are provided with a wheel which is mounted between the same, and by which they are supported, said frame being also provided with a seed or grain box in the bottom of which is an opening which communicates with a chute through which the seed or grain passes, and said frame being also provided rearwardly of said grain or seed box with two ploughs or shovels, one of which is located at each side of the frame, and with a marker, for marking out a succeeding line or furrow, substantially as shown and described. 5th. In a garden implement, the combination with a suitable wheel, of a yoke or frame, the sides of which are mounted on the shaft or axle of said wheel, said yoke being extended backwardly and provided with vertical standards or bars, the lower ends of which are mounted on the shaft or axle of the wheel, said yoke or frame being also provided with suitable shovels or ploughs, and means for adjusting the height of the handle rods or bars, substantially as shown and described.

No. 56,442. Steam boiler. (Chaudière à vapeur.)

Samuel Edgar Snedeker, White Plains, U.S.A., 28th June, 1897; 6 years. (Filed 26th May, 1897.)

Claim.—1st. A steam generator, comprising a furnace, which is provided at the front thereof with a grate, and rearwardly of said

grate with a transverse buffer wall, said furnace being also provided with a downwardly and backwardly directed partition rearwardly

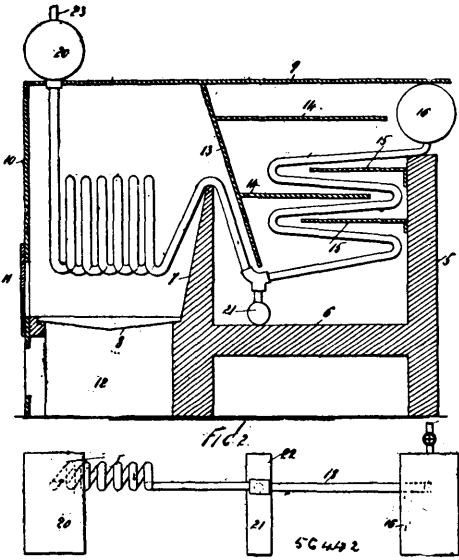

of said buffer wall, and with horizontal partition plates which extend backwardly toward the rear wall of the furnace, and with corresponding partition plates which extend forwardly from the rear wall of the furnace, a water supply drum or vessel mounted over the rear portion of the furnace, a pipe connected therewith, and coiled back and forth longitudinally of the rear portion of the furnace between said partition plates, said pipe being carried downwardly beneath said transverse partition, and then upwardly over said buffer wall, and formed in coils over the grate, said coils being in communication with a steam drum, substantially as shown and described. 2nd. A steam generator, comprising a furnace, which is provided at the front thereof with a grate, and rearwardly of said grate with a transverse buffer wall, said furnace being also provided with a downwardly and backwardly directed partition rearwardly of said buffer wall, and with horizontal partition plates which extend backwardly towards the rear wall of the furnace, a water supply drum or vessel mounted over the rear wall of the furnace, a pipe connected therewith and coiled back and forth longitudinally of the rear portion of the furnace between said partition plates, said pipe being carried downwardly beneath said transverse partition, and then upwardly over said buffer wall, and formed in coils over the grate, said coils being in communication with a steam drum, and the pipe in the rear portion of the furnace being provided below said transverse partition with a mud drum which is in communication therewith, substantially as shown and described.

No. 56,443. Dressing for Harness.

(Huile pour harnais.)

Charles E. House, Yates, Michigan, U.S.A., 28th June, 1897; 6 years. (Filed 26th May, 1897.)

Claim.—An improved oil-dressing composed of logwood, drop-black, fish-oil, copperas, soap, vinegar, extract of potatoes, melted rubber, cottolene, and water, all in the proportions set forth.

No. 56,444. Car Coupler. (Attelage de chars.)

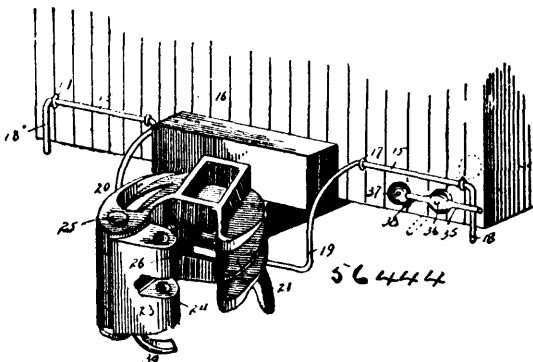

Eugene D. Whipple, Creston, Iowa, U.S.A., 28th June, 1897; 6 years. (Filed 26th May, 1897.)

Claim.—1st. In a car coupler of the vertical-plane type, the combination with the hinged knuckle and the impact arm, of a swinging

locking-block having an engaging abutment or notch thereon, or an abutment or notch upon the draw-head adapted to engage with said former abutment or notch when the locking-block is retracted into its unlocked position, said locking-block also having journals resting in and moving upon bearings in the draw-head, said locking-block being loosely mounted within its journal bearings. 2nd. In a car coupler of the vertical-plane type, the combination with the knuckle and the impact arm, of a swinging locking-block, an engaging face on said locking-block against which the impact-arm contacts in the opening of the said knuckle to impart to the said block an initial movement from its unlocked position, an abutment or abutments upon the drawhead adapted to engage with an abutment or abutments on the locking-block when the latter is retracted into its unlocked position, and intermembering journal bearings on the locking-block and draw-head, whereby the locking-block rotates in falling by gravity into a locking position about a constant centre of rotation. 3rd. In a car coupler of the vertical-plane type, the combination with the knuckle and the impact arm, of a swinging locking block, an engaging face on said locking-block in the form of a bevel, against which a bevel face on the impact-arm bears or presses in the opening of the knuckle, an abutment or abutments upon the draw-head engaged with an abutment or abutments on the locking-block when the latter is retracted into its unlocked position, the bevel face of the impact arm in its engagement with the bevel face on the locking-block disengaging the locking-block from its secured position by virtue of the intermembering abutments and intermembering journal-bearings on the locking-block and draw-head, whereby the locking-block rotates in falling by gravity into a locking position about a constant centre of rotation. 4th. In a car coupler of the vertical-plane type, a removable and replaceable safety-arm secured to a perforated plate-piece, which latter is detachably held on the underside of the draw-head by a dovetail connection, the said safety-arm extending toward the centre of the draw-head. 5th. In a car coupler of the vertical-plane type, a removable and replaceable safety-arm, a perforated plate from which the safety-arm projects, and a knuckle-pin extended through the perforation of the plate, and means for holding the safety-arm and plate on the knuckle-pin. 6th. In a car coupler, a safety-arm projected from a plate held on the draw-head, and a tang engaging the draw-head to hold the plate in position. 7th. In a car coupler, a removable and replaceable safety-arm, a perforated plate from which said safety-arm projects, which plate is held upon the underside of the draw-head by a dovetail connection and a knuckle-pin passing through the plate and held thereto.

No. 56,445. Washing Machine. (Machine à laver.)

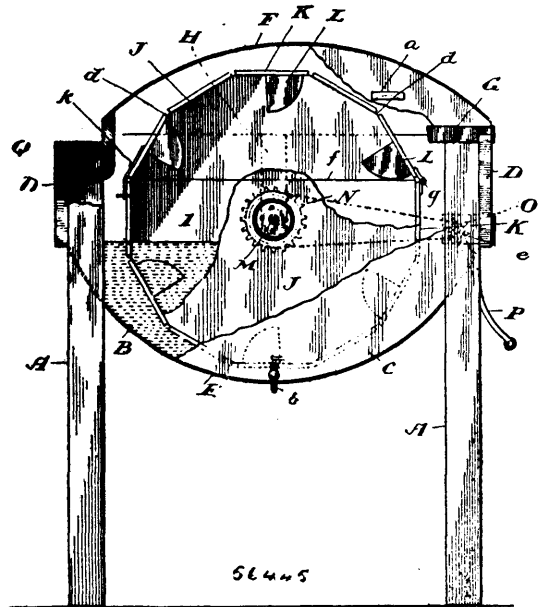

James Adam Gowans, Stratford, Ontario, Canada, 28th June, 1897; 6 years. (Filed 28th May, 1897.)

Claim.—1st. In a washing machine, a washing chamber in combination with a rotatable washing cylinder journaled therein, and a series of projections or pegs projecting from the internal periphery of the cylinder, substantially as and for the purpose specified. 2nd. In a washing machine, a washing chamber in combination with a rotatable washing cylinder journaled therein, and a series of projections or pegs projecting from the internal periphery of the cylinder, openings being formed in the periphery of the cylinder, substantially as and for the purpose specified. 3rd. In a washing machine, a washing chamber and a removable cover for the same

in combination with a rotatable washing cylinder journaled therein and provided with openings for the passage of water, a series of pegs or projections secured to the internal periphery of the cylinder, and a cover or lid for the cylinder provided with suitable fastenings, substantially as and for the purpose specified. 4th. A cylinder for a washing machine comprising the polygonal ends J, provided with gudgeons M, the cross-bar X, with openings d between them, and a series of pegs or projections L, connected to the said cross-bars, substantially as and for the purpose specified. 5th. A cylinder for a washing machine comprising the polygonal ends J, provided with gudgeons M, the cross-bars K, with openings d between them, a series of pegs or projections L, connected to the said cross-bars, the cylinder being divided from end to end and provided with suitable hinges and fastenings, substantially as and for the purpose specified. 6th. A cylinder for a washing machine comprising the polygonal ends J, provided with gudgeons M, the cross-bars K, with openings d between them, and a series of pegs or projections L, connected to the said cross-bars, the cylinder being provided from end to end and provided with suitable hinges and fastenings, substantially as and for the purpose specified. 7th. In a washing machine, a washing chamber provided with a draw-off cock, in combination with a washing cylinder provided with openings for the passage of water, a series of pegs or projections secured to the internal periphery of the cylinder, a cover or lid for the cylinder, gudgeons secured to the ends of the cylinder, removable bearings pieces in the sides of the washing chamber for the said gudgeons, a sprocket-wheel secured to one of the gudgeons, a sprocket-wheel secured to a shaft journaled to the frame of the machine, and a sprocket chain connecting the two sprocket-wheels, substantially as and for the purpose specified.

No. 56,446. Potato Digger. (Arrache-patates.)

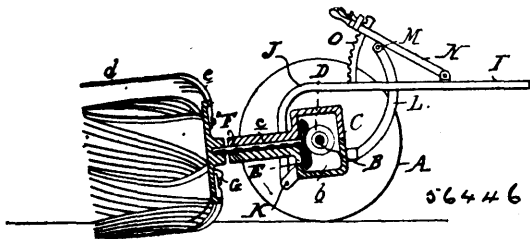

Judson D. Perry, Detroit, Michigan, U.S.A., 28th June, 1897; 6 years. (Filed 28th May, 1897.)

Claim.—1st. In a potato digger, an axially drawn rotary cage, comprising a head and a series of digging scoops arranged around and secured to said head having rearwardly extending tines. 2nd. In a potato digger, an axially drawn rotating cage, comprising a head and a series of digging scoops secured thereto having rearwardly extending tines inclined to roll the potatoes towards the rear of the cage as the scoops are lifted above the ground. 3rd. In a potato digger, an axially drawn rotary cage, comprising a head and a series of digging scoops arranged around and secured to said head, each consisting of the cutting blade d secured to the shanks c and the tines f bent to form a slightly spiral shape to the scoop. 4th. In an agricultural implement, the combination with the wheeled axle, a frame supported thereon and a rearwardly extending shaft journaled in said frame and having a drive connection with said axle, of a draft pole, a yoke frame secured to said pole and pivoted to said frame below the axle, an arm extending forward and upward from the frame beside the pole, a lever pivoted to said pole and bearing on the upper end of said arm, and a segment to which said lever is adjustably locked. 5th. In an agricultural implement, the combination with the wheeled axle, a frame supported thereon and a rearwardly extending shaft journaled in said frame and having a drive connection with said axle, of a draft pole, a yoke frame secured to said pole and pivoted to said frame below the axle, the bifurcated arm L extending forward and upward from said frame and embracing said pole, the roller M at the upper end of said arm, the lever N pivoted to said pole and bearing on the roll M, and the segment O to which said lever is adjustably locked. 6th. In an agricultural implement the combination with a wheeled axle of the frame C sleeved thereon, having bearings a and one or more enlargements b forming gear casing and one or more bearings on said casings for a shaft extending at right angles to the axle.

No. 56,447. Pulverizer. (Broyeur.)

Judson D. Perry, Detroit, Michigan, U.S.A., 28th June, 1897; 6 years. (Filed 28th May, 1897.)

Claim.—1st. A soil pulverizer, comprising an axially drawn rotary head having a series of cutting blades arranged around and secured

thereto, adapted in the rotation of said head to cut through the soil. 2nd. A soil pulverizer, comprising an axially drawn rotary head

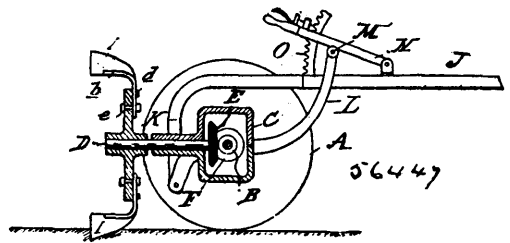

having a series of cutting blades arranged around and secured thereto, adapted in the rotation of said head to make a drawing cut through the soil. 3rd. A soil pulverizer, comprising an axially drawn rotary head, having secured thereto a series of triangular shaped curved cutting blades I adapted in the rotation of the head to cut through and spade up the soil. 4th. A soil pulverizer, comprising a wheeled frame carrying an axially drawn rotating head having secured thereto a series of triangular shaped curved cutting blades I adapted in the rotation of the head to make a drawing cut through the soil, and a draft attachment for said frame permitting said head to lift when an obstruction is struck by the knives.

No. 56,448. Draft Tube for Locomotive Boiler Furnaces. (TUBE de tirage pour foyers de chaudières de locomotives.)

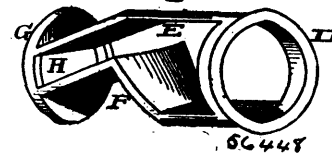
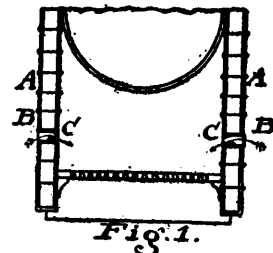

George Cowles Sharpe, Columbus, Ohio, U.S.A., 28th June, 1897; 6 years. (Filed 28th May, 1897.)

Claim.—In a locomotive furnace the combination with the draft-tubes B, B, of the diverting-tubes C, consisting of the rings D, part E extending straight inward two-thirds, thence downward thirty-six degrees, the part F extending inward one-third distance, thence upward at an angle of forty-five degrees, thence downward on a line parallel with parts E, and the disc G joining both parts E and F, and having slot H, leading into the furnace, substantially as described.

No. 56,449. Nut Lock. (Arrête-écrou.)

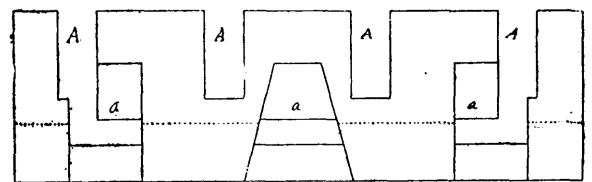

Thomas Walter John O'Meara, Ste. Brigitte des Saults, Canada, 28 juin 1897; 6 ans. (Déposé 7 octobre 1896.)

Résumé.—La combinaison avec les rails R, les éclisses S, S, les boulons et les écrous b, T, d'un coussinet B, ayant les ouvertures A, A, A, A, et les secondes ouvertures a, a, a, le tout déposé tel que décrit et pour les fins indiquées.

TRADE - MARKS

Registered during the month of June, 1897, at the Department of Agriculture--
Copyright and Trade-Mark Branch.

6062. THE McCORMICK MANUFACTURING COMPANY, LIMITED, London, Ont. Biscuits, 1st June, 1897.
6063. THE GOLD MEDAL FURNITURE MANUFACTURING COMPANY, Toronto, Ont. Beds, Mattresses, Woven Wire Mattresses, bed bottoms and woven wire bed bottoms, 1st June, 1897.
6064. SAMUEL T. CHURCH, Toronto, Ont. Name of a System of Educational Training for the Correction of Stammering and analogous voice errors, 2nd June, 1897.
6065. VAN DULKEN, WEILAND & COMPANY, Rotterdam, Holland. Gin, 2nd June, 1897.
6066. VILLENEUVE & COMPAGNIE, Montreal, Que. Cigares, 3 juin 1897.
6067. JOHN KERR MARTIN, Paris, Ont. Washing Compound, 4th June, 1897.
6068. DAVID D. WILSON, Seaforth, Ont. Eggs, 4th June, 1897.
6069. DANIEL BYER, Markham, Ont. Ointment and Antiseptic Healing Wash for the cure of Cancers, Wounds and Sores, 8th June, 1897.
6070. MICHIGAN AMMONIA WORKS, Detroit, Michigan, U.S.A. Ammonia Compounds, 8th June, 1897.
6071. JOHN E. GARRETT, New Glasgow, N.S. Liquid Medicine for internal and external use, 9th June, 1897.
6072. THE NATIONAL CASH REGISTER COMPANY, Dayton, Ohio, U.S.A. Cash Registers, 9th June, 1897.
6073. THE FARBENFABRIKEN, vormals FRIEDRICH BAYER & COMPANY, Elberfeld, Prussia, Germany. An Artificial Fertilizer, 10th June, 1897.
6074. JAMES NICOLL WALKER, St. Catharines, Ont. Pills, 11th June, 1897.
6075. DAVID RUSSELL, St. John, N.B. A Medicinal and Pharmaceutical Preparation, 11th June, 1897.
6076. JOHN S. PEARCE, London, Ont. Cheese Bandage, 11th June, 1897.
6077. ABRAHAM ISAACS, St. John, N.B. Tobacco, Cigars and Cigarettes, 11th June, 1897.
6078. THE ALONZO O. BLISS COMPANY, Washington, D.C., U.S.A. Proprietary Medicine, 11th June, 1897.
6079. JEAN H. LARKIN, Toronto, Ont. Tea, 15th June, 1897.
6080. ROBERT HERRON & COMPANY, Montreal, Que. Baking Powder, 15th June, 1897.
6081. ALLEN S. OLMSTED, Le Roy, New York, U.S.A. Powder for the Feet, 15th June, 1897.
6082. JEYES' SANITARY COMPOUNDS COMPANY, LIMITED, 64 Cannon Street, London, England. General Trade Mark, 15th June, 1897.
6083. THOMAS ELLIOTT, Lambton Mills, Ont. Flour, 16th June, 1897.
6084. THE HAMILTON COFFEE AND SPICE COMPANY, LIMITED, Hamilton, Ont. Baking Powder, 18th June, 1897.
6085. THE J. C. McLAREN BELTING COMPANY, Montreal, Que. Belting, 19th June, 1897.
6086. GEORGE D. ROSS & COMPANY, Montreal, Que. General Trade Mark, 19th June, 1897.
6087. CHARLES ALBERT GRIFFITH, Toronto, Ont. Cut and Plug Tobacco, 23rd June, 1897.
6088. THOMAS KINNEAR, Toronto, Ont. Tea, 23rd June, 1897.
6089. } HERCULES SANCHE, New York, N.Y., U.S.A. Instruments and Appli-
6090. } ces or Apparatus for the cure of Disease, 24th June, 1897.
6091. } Assigned to the ANIMARIUM COMPANY, New York, N.Y.,
6092. } U.S.A.

-
6093. WALTER ERNEST BOOTH, Detroit, Michigan, U.S.A. Bath Tubs, 26th June, 1897.
6094. WILLIAM JAMES RICHARDSON, Rossland, B.C. A Printer's Inksolver or Composition for reducing printer's ink, 26th June, 1897.
6095. WILLIAM BUCK, Brantford, Ont. Fire Bricks, 28th June, 1897.
6096. JESSE JAMES FOSTER, Toronto, Ont. Dr. Ward's Blood and Nerve Pills, 28th June, 1897.
6097. ARSENE A. LAROCQUE, Joliette, Que. Manufactured Cut and Plug Tobacco, 29th June, 1897.
6098. F. B. DAKIN & COMPANY, Iberville, Que. Earthenware Sanitary Goods, and more particularly Water Closets, 29th June, 1897.
6099. OSWALD MAY MALCOLM, Vancouver, B.C. Canned Salmon, 29th June, 1897.
6100. GEORGE ROBERTSON & SON, Kingston, Ont. Tea, 29th June, 1897.

COPYRIGHTS

Entered during the month of June, 1897, at the Department of Agriculture--
Copyright and Trade-Mark Branch.

9270. A PRACTICAL CATECHISM ON BAPTISM. By John Laing, M.A., D.D. Wm. Briggs (Book-Steward of the Methodist Book and Publishing House), Toronto, Ont., 1st June, 1897.
9271. MAP OF TRAIL CREEK MINING CAMP, WEST KOOTENAY DISTRICT, B.C. McGregor, Atkinson & Co., Rossland, B.C., 1st June, 1897.
9272. THE BELL TELEPHONE COMPANY OF CANADA, LIMITED, DISTRICT OF EASTERN ONTARIO, SUBSCRIBERS' DIRECTORY, MAY, 1897. The Bell Telephone Company of Canada (Ltd.), Montreal, Que., 1st June, 1897.
9273. MURRAY'S INTEREST TABLES. B. W. Murray, Toronto, Ont., 1st June, 1897.
9274. HARK! THE DRUM. (Patriotic Song.) Words and Music by H. H. Godfrey, Toronto, Ont., 2nd June, 1897.
9275. L'INDICATEUR DE QUÉBEC ET LÉVIS, 1897-98. (The Quebec and Lévis Directory.) Boulanger et Marcotte, Québec, Qué., 2 juin 1897.
9276. MOTHER-LAND BEYOND THE SEA. Words and Music by Kate Macintosh. Wm. Briggs (Book-Steward of the Methodist Book and Publishing House), Toronto, Ont., 3rd June, 1897.
9277. THE MONTREAL SUBURBAN CYCLING AND SPORTING GUIDE, 1897. (With Map.) James Ewing, Montreal, Que., 3rd June, 1897.
9278. THE CANADIAN MAGAZINE. (June, 1897.) The Ontario Publishing Company (Ltd.), Toronto, Ont., 4th June, 1897.
9279. AS LONG AS THERE'S LOVE IN YOUR HEART. Words and Music by Chas. Graham. Arranged by Hermann Schloss. Whaley, Royce & Co., Toronto, Ont., 4th June, 1897.
9280. GAYEST MANHATTAN. (March and Two-Step.) By J. W. Bratton. Whaley, Royce & Co., Toronto, Ont., 4th June, 1897.
9281. GENEVIEVE! THE TALK OF THE TOWN. (Song and Chorus.) Words by Walter H. Ford. Music by John W. Bratton. Whaley, Royce & Co., Toronto, Ont., 4th June, 1897.
9282. KATE O'DONOGHUE. (Song and Chorus.) Words and Music by Chauncey Olcott. Whaley, Royce & Co., Toronto, Ont., 4th June, 1897.
9283. SADIE, MY LADY. (Song and Chorus.) Words by W. H. Ford. Music by J. W. Bratton. Whaley, Royce & Co., Toronto, Ont., 4th June, 1897.
9284. THE OLD-FASHIONED MOTHER. Words and Music by Chauncey Olcott. Whaley, Royce & Co., Toronto, Ont., 4th June, 1897.
9285. WAY DOWN IN CAROLINA; OR, IRENE. Words and Music by L. O. Vincent. Whaley, Royce & Co., Toronto, Ont., 4th June, 1897.
9286. QUINTE. (Prelude and Song.) Words by Rozelle V. Funnell, M.D. Music by Cecil J. A. Birkett. Rozelle V. Funnell, M.D., Ottawa, Ont., 4th June, 1897.
9287. ART SUPPLEMENT OF THE DAILY MAIL AND EMPIRE, TORONTO, SATURDAY, 5TH JUNE, 1897. The Mail Printing Company, Toronto, Ont., 5th June, 1897.
9288. THE STORY OF THE FLAG. (Song.) Words and Music by H. H. Godfrey, Toronto, Ont., 5th June, 1897.
9289. CANADA'S DIAMOND JUBILEE MARCH. By Marsh Jones, Watford, Ont., 5th June, 1897.
9290. LIFE AND WORK OF D. J. MACDONNELL, MINISTER OF ST. ANDREW'S CHURCH, TORONTO, (with a Selection of Sermons and Prayers.) Edited by Prof. J. F. McCurdy, Ph. D., LL.D. With Protraits and Illustrations. Wm. Briggs (Book-Steward of the Methodist Book and Publishing House), Toronto, Ont., 7th June, 1897.
9291. THE WESTMINSTER. (A Paper for the Home. Vol. II, No. 6, June, 1897.) The Westminster Company, Toronto, Ont., 7th June, 1897.

9292. MASSEY'S MAGAZINE. (June, 1897.) The Massey Press, Toronto, Ont., 8th June, 1897.
9293. MINING MAP OF THE LAKE OF THE WOODS AND SHOAL LAKE, DISTRICT OF RAINY RIVER. Compiled by Chalmers and Charlesworth, O.L.S. L. C. Charlesworth and John Chalmers Rat Portage, Ont., 8th June, 1897.
9294. ESTABELLE AND OTHER VERSE. By John Stuart Thomson. William Briggs (Book-Steward of the Methodist Book and Publishing House), Toronto, Ont., 9th June, 1897.
9295. STUDENTS' REFERENCE BOOK OF HISTORY AND GEOGRAPHY. By Wm. R. Wood, Riverbank, Ont., 9th June, 1897.
9296. TOKEN OF LOVE WALTZES. By Maurice Laurent. Willimott H. Billing, Toronto, Ont., 9th June, 1897.
9297. MY GIRL IS A WINNER! Words and Music by E. Nattes. Whaley, Royce & Co., Toronto, Ont., 9th June, 1897.
9298. QUEEN'S JUBILEE WALTZ. By Captain R. G. Dickson, Niagara-on-the-Lake, Ont., 10th June, 1897.
9299. JOHN SAINT JOHN AND ANNA GREY. (A Romance of Old New Brunswick.) By Margaret Gill Currie. Wm. Briggs (Book-Steward of the Methodist Book and Publishing House), Toronto, Ont., 10th June, 1897.
9300. THE LION AND THE LILIES. (A Tale of the Conquest and Other Poems.) By Charles Edwin Jakeway. Wm. Briggs (Book-Steward of the Methodist Book and Publishing House), Toronto, Ont., 10th June, 1897.
9301. GUARANTEED DIVIDEND BOND. (Policy-form.) The Excelsior Life Insurance Company of Ontario, Limited, Toronto, Ont., 11th June, 1897.
9302. GUARANTEED DIVIDEND BOND RATES AND GUARANTEED OPTIONS. (Leaflet.) The Excelsior Life Insurance Company of Ontario, Limited, Toronto, Ont., 11th June, 1897.
9303. MAPS OF THE LAURENTIAN, SHAWENEGAN, ST. MAURICE AND WINCHESTER CLUBS. By Aurélien Boyer, C.E., Montreal, Que., 11th June, 1897.
9304. THE MILITARY JUBILEE GAME RULES. John McLean Sutherland, Lancaster, Ont., 11th June, 1897.
9305. ART SUPPLEMENT OF THE DAILY MAIL AND EMPIRE, TORONTO, SATURDAY, 12TH JUNE, 1897. The Mail Printing Company, Toronto, Ont., 12th June, 1897.
9306. THE DELINEATOR. (A Journal of Fashion, Culture and Fine Arts. July, 1897.) The Butterick Publishing Company (Ltd.), New York, N.Y., U.S.A., 12th June, 1897.
9307. THE GLASS OF FASHION UP TO DATE. (July, 1897.) The Butterick Publishing Company (Ltd.), New York, N.Y., U.S.A., 12th June, 1897.
9308. DREAM OF THE PAST WALTZ. By Carl Faust. Willimott H. Billing, Toronto, Ont., 12th June, 1897.
9309. OPEN AND READ. (Re The Ontario Mutual Life Assurance Company.) W. H. Riddell, Waterloo, Ont., 12th June, 1897.
9310. HISTOIRE DE LA SEIGNEURIE DE LAUZON. (Premier Volume. Par J. Edmond Roy, Lévis, Qué., 14 juin 1897.
9311. ON WINGS OF STEEL. (Wheeling Song.) Words and Music by H. H. Godfrey, Toronto, Ont., 15th June, 1897.
9312. THE GAY McCARTY. (Song.) Words by David Battle. Music by J. Norris Hillman. David Battle, Thorold, Ont., 16th June, 1897.
9313. HISTORY OF THE COUNTY OF ANNAPOLIS, INCLUDING OLD PORT ROYAL AND ACADIA. By the late W. A. Calnek. Edited and completed by A. W. Savary, M.A., Annapolis Royal, N.S., 17th June, 1897.
9314. MAP OF ROSSLAND AND ITS MINES. Compiled by C. H. Ellacott, B.A.Sc., P.L.S., Rossland, B.C., 18th June, 1897.
9315. JUBILEE SONGS OF THE ANGLIO-SAXON RACE. Words by John Woodruff. Music by Herbert Spencer. John Woodruff, Ottawa, Ont., 18th June, 1897.
9316. CORYELL'S MAP OF PORTION OF KETTLE RIVER MINING DIVISION, BRITISH COLUMBIA. John A. Coryell, Midway, B.C., 18th June, 1897.

9317. DIAMOND JUBILEE OFFICIAL PROGRAMME OF THE CITY OF TORONTO, 22ND JUNE, 1897. C. E. Choat, Toronto, Ont., 18th June, 1897.
9318. CANADIAN QUEEN'S JUBILEE SONG. Words by Wm. Little. Music by Ach. Fortier. Wm. Little, Montreal, Que., 19th June, 1897.
9319. ARTS SUPPLEMENT OF THE DAILY MAIL AND EMPIRE, TORONTO, SATURDAY, 19TH JUNE, 1897. The Mail Printing Company, Toronto, Ont., 19th June, 1897.
9320. TORONTO ILLUSTRATED GUIDE BOOK AND SOUVENIR. Compiled by J. Lawlor Woods. G. M. Rose & Sons, Toronto, Ont., 19th June, 1897.
9321. THE VICTORIA DIAMOND JUBILEE HISTORY OF CANADA. By Wm. Peter Smith, Esq., M.A., F.R.C.S. G. M. Rose & Sons, Toronto, Ont., 19th June, 1897.
9322. VICTORIA SIXTY YEARS A QUEEN. (A Sketch of Her Life and Times.) By Richard T. Lancefield. With an Introduction by Hon. G. W. Ross, LL.D. G. M. Rose & Sons, Toronto, Ont., 19th June, 1897.
9323. CANADIAN SUMMER RESORT GUIDE, 1897. (Fourth Edition.) Frederick Smily, Toronto, Ont., 19th June, 1897.
9324. EQUALITY. By Edward Bellamy. D. Appleton & Co., New York, N.Y., U.S.A., 19th June, 1897.
9325. DIAMOND JUBILEE SUNDAY SCHOOL SOUVENIR. (Card.) The Endeavor Herald Company, Toronto, Ont., 23rd June, 1897.
9326. THE BROKEN WING. (Song with Violin or Flute Obligato.) Words by H. Butterworth. Music by John C. Walling. Whaley, Royce & Co., Toronto, Ont., 23rd June, 1897.
9327. THE DOMINION CONVEYANCER. By Wm. Howard Hunter, B.A. (Second Edition.) The Carswell Company (Ltd.), Toronto, Ont., 25th June, 1897.
9328. FIRE INSURANCE LAW OF ONTARIO. Compiled by R. J. MacLennan, Barrister. The Carswell Company (Ltd.), Toronto, Ont., 25th June, 1897.
9329. ARTS SUPPLEMENT OF THE DAILY MAIL AND EMPIRE, TORONTO, SATURDAY, 26TH JUNE, 1897. The Mail Printing Company, Toronto, Ont., 26th June, 1897.
9330. APPLICATION AND CONTRACT OF THE YORK COUNTY LOAN AND SAVINGS COMPANY. Joseph Phillips, Toronto, Ont., 28th June, 1897.
9331. CIRCULAR OF THE YORK COUNTY LOAN AND SAVINGS COMPANY. Joseph Phillips, Toronto, Ont., 28th June, 1897.
9332. CLASS B CERTIFICATE OF THE YORK COUNTY LOAN AND SAVINGS COMPANY. Joseph Phillips, Toronto, Ont., 28th June, 1897.
9333. RECREATION MARCH. (Two-Step.) By Jeff. Rice. Colin C. McPhee, Chatham, Ont., 30th June, 1897.