

Technical and Bibliographic Notes / Notes techniques et bibliographiques

The Institute has attempted to obtain the best original copy available for filming. Features of this copy which may be bibliographically unique, which may alter any of the images in the reproduction, or which may significantly change the usual method of filming, are checked below.

L'Institut a microfilmé le meilleur exemplaire qu'il lui a été possible de se procurer. Les détails de cet exemplaire qui sont peut-être uniques du point de vue bibliographique, qui peuvent modifier une image reproduite, ou qui peuvent exiger une modification dans la méthode normale de filmage sont indiqués ci-dessous.

Coloured covers/
Couverture de couleur

Coloured pages/
Pages de couleur

Covers damaged/
Couverture endommagée

Pages damaged/
Pages endommagées

Covers restored and/or laminated/
Couverture restaurée et/ou pelliculée

Pages restored and/or laminated/
Pages restaurées et/ou pelliculées

Cover title missing/
Le titre de couverture manque

Pages discoloured, stained or foxed/
Pages décolorées, tachetées ou piquées

Coloured maps/
Cartes géographiques en couleur

Pages detached/
Pages détachées

Coloured ink (i.e. other than blue or black)/
Encre de couleur (i.e. autre que bleue ou noire)

Showthrough/
Transparence

Coloured plates and/or illustrations/
Planches et/ou illustrations en couleur

Quality of print varies/
Qualité inégale de l'impression

Bound with other material/
Relié avec d'autres documents

Continuous pagination/
Pagination continue

Tight binding may cause shadows or distortion along interior margin/
La reliure serrée peut causer de l'ombre ou de la distorsion le long de la marge intérieure

Includes index(es)/
Comprend un (des) index

Title on header taken from:/
Le titre de l'en-tête provient:

Blank leaves added during restoration may appear within the text. Whenever possible, these have been omitted from filming/
Il se peut que certaines pages blanches ajoutées lors d'une restauration apparaissent dans le texte, mais, lorsque cela était possible, ces pages n'ont pas été filmées.

Title page of issue/
Page de titre de la livraison

Caption of issue/
Titre de départ de la livraison

Masthead/
Générique (périodiques) de la livraison

Additional comments:/
Commentaires supplémentaires:

This item is filmed at the reduction ratio checked below/
Ce document est filmé au taux de réduction indiqué ci-dessous.

10X	12X	14X	16X	18X	20X	22X	24X	26X	28X	30X	32X
								✓			

The Canadian Patent Office

RECORD



Vol III.—No. 11.

NOVEMBER, 1875.

Price in Canada \$2 00 per An.
United States - \$2 50

CONTENTS.

INVENTIONS PATENTED.....	157
INDEX OF INVENTIONS.....	CLXVI
INDEX OF PATENTEES.....	CLXVII
ILLUSTRATIONS.....	169

INVENTIONS PATENTED.

No. 5153. CHARLES BOECKH, Toronto, Ont., 8th September, 1875, for 5 years: "Improvements in Fibre and Bristle Combing Machines." (Perfectionnements aux machines à peigner les fibres et les soies de cochon.)

Claim.—1st. The combination with the frame G, G, provided with the bevelled flanged faces g, g, and revolving comb J, of the slotted guard plates K, K, or their equivalent; 2nd. The crank shaft H, with cone wheel I, comb J, and rods J, in combination with the driving shaft B, operated from the foot treadle E.

No. 5154. JAMES H. SHELDON, Chicago, Ill., U. S., (Co-inventor with and Assignee of W. W. HORTON), 8th September, 1875, for 5 years: "Improvements in the Manufacture of Illuminating Gas." (Perfectionnements dans la fabrication du gaz d'éclairage.)

Claim.—1st. The process of making illuminating gas by enriching gas evolved from wood or vegetable substances, by distilling hydrocarbons with such gas after it has been cleaned of its impurities, 2nd. The process of making illuminating gas by distilling hydrocarbons and uniting with their product, in the same retorts under high heat, gas evolved from wood or vegetable substances after being deprived of its impurities, 3rd. The process of making an illuminating gas by a union of gas evolved from wood or vegetable substances after being purified and gas evolved from hydrocarbons by heat, the union taking place at a common high temperature.

No. 5155. GEORGE H. THOMPSON, Oneida, AGUSTUS A. MATHEWS and MARCUS O. MATHEWS, Seneca, Ont., 10th September, 1875, for 5 years: "Apparatus to Prevent Horses from Jumping." (Appareil pour empêcher les chevaux de sauter.)

Claims.—1st. The circular shape of the projection B, 2nd. The mode of attaching to the halter, the hooks a, a, and the loose rings z, z. 3rd. The mode of attaching the strap by the loops o, o.

No. 5156. JAMES D. MANN, Kentville, N. S., 10th September, 1875, for 5 years: "Snow Plough." (Charrue à neige.)

Claim.—1st. The combination of the inclined surface A, with the snow-splitters B, B, and mould board C, 2nd. The combination of the flanges D, D, with the parallel sides E, E, and mould board C.

No. 5157. JOHN GUEST, jr., Merrickville, Ont., 10th September, 1875, for 5 years: "Churn Power." (Moteur de baratte.)

Claim.—1st. The adjustable eye f having screws secured by nuts g, in combination with the wheel D, having slots d, d. 2nd. The adjustable counter balance weight G, having screws secured by nuts g, in combination with the wheel D, having slots e, e.

No. 5158. ROBERT GILCHRIST, Louisville, Ky., U. S., 10th September, 1875, for 5 years: "Extension Ladder." (Echelle à rallonge.)

Claim.—1st. Two or more ladders E, E, pivoted together and applied one within the other, the pivot bolts serving as stepping rounds and bearings, in combination with finger bolts h, having pieces h, pivoted to them; 2nd. Pulleys G, G, with their ropes combined with eyes f, and ladders which are pivoted to standards B, and which are also pivoted together.

No. 5159. JAMES EDGAR, New York, U. S., 10th September, 1875, for 5 years: "Coal Shovel." (Pelle à charbon.)

Claim.—1st. A shovel stamped up of sheet metal together with its concave handle; 2nd. The combination of a projector C, with the concave handle B, of a scoop A.

No. 5160. JOHN W. MANN, Woodhouse, Ont., 10th September, 1875, for 10 years: "Seed Sower." (Semoir à grains.)

Claim.—1st. The manner of perforating the plate P, and sliding plate Q, through which the seeds pass and are evenly and uniformly distributed on the ground, 2nd. The construction and mode of working of the seed shifter M, by which the seeds are impelled through the holes, 3rd. The motion communicated to it through the arm F, by working in the grooved collar E.

No. 5161. FRANCIS M. GARDNER, Hornellsville, N. Y., U. S., 10th September, 1875, for 5 years: "Lifting Attachment for Shovels and Forks." (Appareil à lever les pelles et les fourches.)

Claim.—1st. A lifting attachment consisting of one or two arms and a handle, the one or both arms provided with a hook for attaching and detaching at will with lugs or clips on the handle, or with the blade of an ordinary shovel or scoop, or with the cross-bar or head of a pitch-fork, upon each side of the main rigid-handle, 2nd. The clamp or clip D, removably secured to the handle for the connection of the lifting attachment.

No. 5162. CHARLES B. LONG, Worcester, Mass., U. S., 10th September, 1875, for 5 years: "Leather Crimping Machine." (Machine à cambrer les cuirs.)

Claims.—1st. The pressure plates I, within the frames H, H, provided with projections f, f, in combination with the right and left hand screws F, 2nd. The pressure-plates I, within the frames H, H, operated automatically by the right and left hand screws F, in combination with the gears 1, 2, and 3 and the weighted levers L; 3rd. A series of crimping-jaws I, arranged one above the other, in combination with a series of levers adapted A to vary the gripping-power of the jaws and to act independently upon each pair of jaws, 4th. The jaws or plates I, provided with right and left threaded devices for their positive adjustment in combination with the weighted levers L, 5th. The clamping jaws R, provided with the stems y, y, and levers 7, and 8 and adapted to be operated by rods z, z; 6th. In combination with the clamping jaws R, provided with a suitable guide for direction, the ear lever 7, connecting rod z and lever O; 7th. The combination of the lag z, spring catch l, lever Q, and upright shaft provided with a forked device for operating the clutch for engaging or releasing the pulley C; 8th. The combination of hand lever O, and pivoted lever P, forked arm K, and a weighted lever L; 9th. In combination with the endless chain c, provided with projections s and the pivoted cranks v, 10th. The combination with the presser plates I of the projections f, f, right and left hand screws F, gears 1, 2, and 3, levers L, and weights J; 11th. The combination of the plates I, projections f, f, right and left screws F, gears 1, 2, and 3,

levers L, forked upright K₁, and pivoted levers P and M; 12th. In combination with the plates I, and their supporting projections f, f₁, right and left screws for operating said plates, and the forms F, 13th. The combination of the forms F, of the plates I, right and left screws F₁, gears 1, 2 and 3, weighted levers L, pivoted cranks v, and endless chain c₁, provided with projections for automatically operating or applying pressure to the material in its passage between the jaws, 14th. The combination with the form or forms F, of the plates I, right and left screws F₁, gears 1, 2, and 3, weighted levers L, pivoted cranks v, projections 4, endless chain c₁, provided with ears s, chain wheel E, gear C, and driving shaft B₁, 15th. The combination with the form F, of plates I, right and left screws F₁, gears 1, 2, and 3, levers L, pivoted cranks v, chain c₁, provided with lugs or ears s, chain wheel E, gear C, driving shaft B₁, and clutch and lever S, 16th. The combination of the presser-plates I, pressure screws F, gears 1, 2, and 3, lever L, forked rod K, levers P and M, lever O₁, clutch wheel C₁, gear C, chain wheel E, chain c₁, lug S, and pivoted cranks v; 17th. The combination of clamping jaws R, pivoted ear or lever 7, 8, rods z, z₁, foot lever or treadle O₁, with projections 9, 10, for automatic disengagement of the material.

No. 5163. WILLIAM D. EWART, Chicago, Ill., U. S., 10th September, 1875, for 5 years: "Drive-Chain." (Chaîne à traîner.)

Claim.—1st. An open hook C, in combination with the link of a drive chain adapted to be coupled together; 2nd. The combination of the open hook C, and side bar A, made sufficiently small near the end bar B, to pass through the opening of the hook; 3rd. The ribs d, made upon the open link of a drive chain; 4th. The link of a drive-chain with an open hook C, cast on a chill in the shape shown; 5th. The coupling hook C, cast on the end-bar of the link of a drive-chain.

No. 5164. LAWRENCE GLYNN, Cambridgeport, Mass., U. S., 10th September, 1875, for 5 years: "Pipe Wrench." (Clé à tuyaux.)

Claim.—The combination of the handle a, hook jaw b, hinge c, and adjustable toothed jaw d, e, f, arranged and secured in a slotted opening through the handle a.

No. 5165. HIRAM W. WHITE, Oskaloosa, Iowa, U. S., 10th September, 1875, for 5 years: "Guitar Head." (Sommier de guitare.)

Claim.—The hollow spindle D, sliding rod E, knob B, and worm wheel b, in combination with the screw key C.

No. 5166. HIRAM W. WHITE, Oskaloosa, Iowa, U. S., 10th September, 1875, for 5 years: "Chin-Rest for Violins." (Mentonnière de violon.)

Claim.—1st. The chin-rest A, and attaching-clamp hook C, connected by a set screw B, and working in a threaded socket in the rest A, 2nd. The combination of the supplemental set screw D, with the clamp hook C, attaching screw B, and chin rest A.

No. 5167. HIRAM W. WHITE, Oskaloosa, Iowa, U. S., 10th September, 1875, for 5 years: "Chin-Rest for Violins." (Mentonnière de violon.)

Claim.—The chin rest F, with clamp hook H, attached to a shank G, screwed adjustably into the said rest F.

No. 5168. ALEXANDRE MANBRÉ, Penge, Eug., 10th September, 1875, for 5 years: "Process and Apparatus for Breaking Cereals and other Vegetable Substances for the Extraction of Fatty Matter therefrom and the Manufacture of Sugar and the Production of Spirits, &c." (Procédé et appareil de traitement des céréales et autres végétaux pour l'extraction des matières grasses et la fabrication du sucre et des spiritueux, &c.)

Claim.—1st. The removal of fatty matter from cereals and other vegetable substances by distillation; 2nd. The treatment of grain seed, nuts, roots, and other vegetable substances containing fatty and starchy matters by distilling off the fatty matter and converting the starchy matter into saccharine matter in one operation; 3rd. The production of a saccharine substance entirely free from fatty matter; 4th. The converting and distilling apparatus constructed with a body a, lined with non corrosive metal and provided with the pipe b, for the introduction of the material to be heated, the pipe c, for the admission of steam, the distilling pipe d.

No. 5169. JOHN COMMINS, Charleston, S. C., U. S., 10th September, 1875, for 15 years: "Fire Kindler." (Allumoir de feu.)

Claim.—1st. A kindling material composed of lumps or pieces of coal, coke or charcoal coated with an inflammable composition; 2nd. A kind-

ling material composed of lumps or pieces of coal, coke or charcoal coated with a solution of rosin and gum turpentine, charcoal dust, coal dust and saw dust; 3rd. A kindling material in which charcoal dust and coal dust are used as a coating upon lumps or pieces of coal.

No. 5170. ABEL F. SKIDMORE and ENOS MOORE, Litchfield, Mich., U. S., 10th September, 1875, for 5 years: "Hoop Machine." (Machine à cercles.)

Claim.—1st. The shuttle B, provided with knives C, and oscillating knives D, 2nd. The knife D, operated by spring, for bevelling the ends of the hoops in combination with the guide T, 3rd. The arm X, rod P, elbows O, arms Q, pawls R, R, and springs S, S, S₁, in combination with the ratchet wheels K and feed roller F.

No. 5171. ISAAC C. RICHARDSON, Nashua, N. H., U. S., 10th September, 1875, for 5 years: "Steam Heating Apparatus." (Appareil de chauffage à la vapeur.)

Claim.—1st. The radiators N, composed of the concentric chambers O, O, separated by annular air spaces P, P, and held in position by flanged and grooved rings R, R, and the transverse angled flue S, combined with the tubes M, T, and boiler B; 2nd. The tubes G, and D, arranged and combined with the tank C, and boiler B; 3rd. The float H, and bent hollow stem I, attached to its bottom, in combination with the tank C, and chamber F.

No. 5172. ELI B. WHITE, Arkona, Ont., 10th September, 1875, for 5 years: "Barrel or Circular Box." (Baril ou boîte circulaire.)

Claim.—A barrel or cylindrical box composed of two sheets of wood A, B, cylindrically made; the grain of the wood diagonal, and with respect to each other transversely; and the intermediate sheet of wood c, cylindrically made, with the fibre running longitudinally with or without the strip D or other fastening.

No. 5173. HENRY WAUDBY, Toronto, Ont., 13th September, 1875 (Extension of Patent No. 603), for 5 years: "Machine for making Stove-pipe Stones." (Machine à faire des douilles de tuyaux de poêles en pierre.)

Claim.—1st. The general arrangement of the sides A, B, C, D and E, 2nd. The cylindrical shaped metallic sheet G, which in combination with the wooden cove F, forms the cove for the stove-pipe hole, the said metallic sheet G, being so made that it may be withdrawn from the casting.

No. 5174. EDWARD BIDDLE, Carlin, Nev., U. S., 14th September, 1875, for 5 years: "Hydraulic Jack." (Cric Hydraulique.)

Claim.—The rectangular-tube A₁, A₂, ram B, piston C, and screw C₁.

No. 5175. JOHN RICE, Black Brook, N. B., 14th September, 1875, for 5 years: "Roller Hoisting Apparatus for Saw-mills." (Appareil à élever les fendeurs de scieries.)

Claim.—The combination of the hoisting drum or axle C, chain E, and wheel D, with the pressure roller A, the wheel D, being geared with a friction drum I, arranged to connect and disconnect at will.

No. 5176. JOHN REGAN, Ottawa, Ont., 14th September, 1875, for 5 years: "Frannings and Moulds to make Wells, Cement Pipes, Drains, &c." (Moulinets et moules pour faire les puits, tuyaux en ciment, drains, &c.)

Claim.—1st. The combination of the centred frame A, and the stone corbel B, with the formation for core C, and the core D, to build a spring well or other well, and make its cement pipes; 2nd. The combination of the float F, the core G, the junction core H, and the formation for core I, to make cement pipes, drains and sewers, and the junctions and shafts thereof; 3rd. The construction of said cement pipes and pipe drains, sewers, shafts and well trenches made also of cement or cement and concrete.

No. 5177. JAMES B. CLARK, Plantsville, Ct., U. S., 14th September, 1875, for 5 years: "Dies for Heading and Squaring Bolts." (Estampe pour entêter et écarri les boulons.)

Claim.—The combination of the stationary holding die g, with the movable shaping die c, and heading die.

No. 5178. HENRY BOLTON, Elizabethtown, Ont., 14th September, 1875, for 5 years: "Potato-digger." (Arache-patates.)

Claim.—1st The plate E adjustably attached to the standard B, for securing the horizontal spring-arms D: 2nd The plate E secured to the standard and having the gains G, for the adjustment of the arms D.

No. 5179. JOHN A. MACKINNON, Sandwich, Ont., 14th September, 1875 (Extension of Patent No. 627), for 5 years: "Improvements on Whistle-trees." (Perfectionnements aux palonniers.)

Claim.—1st. The novel combination of shell a, hooks b, bi, bolts c, bolts or rods d, holes dt, springs e, chain or cord f, chain g, pulleys h, pins i, divisions j, and spring coverings k: 2nd. The novel combination of the hook bi, holes dt, bolts or rods d, springs e, chain or cord f, and chain g, or their equivalents, together with the other parts of the whistle-tree.

No. 5180. WILLIAM R. FENERTY, Halifax, N. S., 20th September, 1875, for 5 years: "File and Tool Handle." (Manche de lime et d'outils.)

Claim.—1st. The combination of the metallic handle A, A, and the wooden plug B, or B2. 2nd The combination with the handle A, A, and plug B, or B2, of the screw thread E, and the shape F, F, to H, H, as set forth.

No. 5181. GEORGE KELLY, London, Eng., 20th September, 1875, for 5 years: "Feather Renovating Machine." (Machine à rafraîchir la plume.)

Claim.—1st. The box A, with double casing C, D, to lower half, and having sliding door N, screw M, and lid I, the whole supported on legs B, B: 2nd. A feather renovating apparatus A, the construction of double casing C, D, the upper one having a series of perforations K1, and operating in conjunction with space E, and steam inlets J, K, either as dampening or drying chambers as required: 3rd. In combination with the preceding claims the paddles G, G1, G2, G3, operated by shaft F, and crank H.

No. 5182. JOHN W. JOHNSON, CHARLES M. MANVILLE, STEPHEN W. ALVORD EDWIN E. BUFFINGTON, LYMAN B. RODGERS, ELIJAH R. MYER, ISAAC WOSBURG and COLIN F. NICHOLS, Towanda, Pa., U. S., and CHARLES M. DUNLAP, Seaforth, Ont., 20th September, 1875, for 5 years: "Fanning Mill." (Tarrare ventilateur.)

Claim.—1st. The vibrating shoe H, provided with the inclines j, j1, K, screens h, h1, and E: 2nd. The long screen E, provided with the finer and coarser sieves i, i2, and valve M: 3rd. The fan shaft b, provided at both ends with crank pinions B, B1, the latter driving a smaller crank pinion B2 in combination with the transferable connecting rods c, f, elbow lever f1, on the removable bracket F, and removable crank arm D, on the rocking shaft D1.

No. 5183. GEORGE H. BLISS, West-Stockbridge, Mass., U. S., 20th September, 1875, for 5 years: "Culinary Apparatus." (Appareil de cuisine.)

Claim.—1st. The combination of the vessel A, closed at the top by a suitable cover, and open at the bottom, and adapted to be used upon the top of a stove or range by being placed over an opening therein directly over the fire, and a double leaved folding gridiron or skeleton food-holder C, supported vertically therein in a position to admit of a free and equal access of the heat from the fire to both sides thereof, to cook both sides of the food contained therein without turning: 2nd. In combination with the bottomless vessel A, adapted to be used upon the top of a stove or range by placing it over an opening therein directly over the fire and the gridiron or food-holder C, supported vertically therein the trough or spout D, provided with the air tube or space E, beneath it: 3rd. In combination with the bottomless vessel or casing A, adapted to use upon the top of a stove or range by placing it over an opening therein directly over the fire, and the gridiron or food-holder C, supported vertically therein in position to admit of a free and equal access of the heat of the fire to both sides thereof, the detachable trough or spout D, arranged to form the upper side or cover of the air passage E. 4th. The combination of the bottomless vessel or casing A, adapted to use upon the top of a stove or range, the double leaved gridiron or skeleton food holder C, supported vertically therein and the inclined trough or spout D, and tube E, made in one piece and detachably mounted in the lower end of said casing A: 5th. The combination of the bottomless vessel or casing A, adapted to use upon the top of a stove or range, the double leaved gridiron, or skeleton food holder C, supported vertically therein, the inclined trough or spout D, projecting through the side of the casing A, and the detachable drip pan F, suspended from said projecting spout.

No. 5184. ALBERT CUNNINGHAM, Milwaukee, Wis., U. S., 20th September, 1875, for 5 years: "Saw-mill Dog." (Clameau de scierie.)

Claim.—1st In combination with two or more sets of dogs attached to a saw mill carriage, the shaft R, R1, provided with the universal joints Q, Q, and with the extension feathered coupling sleeve S. 2nd The dog I, having two teeth or hooks, 3rd. In combination with the bed plate A the dogs I I 1, moving in a curved line and the dogs b, b, b, moving in a straight line, both adapted to be projected into a log simultaneously from opposite directions. 4th. The combination of lever H, pawl L, spring J, and pin i: 5th. The combination of lever H, cam N, arm F, and plate E, 6th. The combination of lever H, connecting rod C, connecting bar D, and dogs I I 1: 7th The combination of lever H, pawl I, and ratchet y.

No. 5185. FRANKLIN H. KALBFLEISCH, New York, U. S., 20th September, 1875, for 5 years: "Carrier for Acid." (Ustensile pour les acides.)

Claim.—A carrier for caustic acids provided with a pouring nozzle and lined with lead extending through the nozzle and overlapping its upper surface or edge.

No. 5186. GEORGE WALLING, Port Perry, Ont., 20th September, 1875, for 5 years: "Machine for Producing a Current of Cold Air around Mill Stones." (Machine à produire un courant d'air froid autour des meules des moulins.)

Claim.—1st. The combination of the suction wheel E, with the tube or box D1, D2, or D3, D2, the covered conveyer box A, and the air tight spouts B, B: 2nd. The combination of the chamber I, as a receptacle of flour with the tube or box D1, D2, or D3, D2, and the wheel E: 3rd. The combination of the air-tube K, K, and the spouts B, B, and the suction wheel E. 4th. The combination of the suction wheel E, with the tubes K, K, and the curb of the millstones.

No. 5187. JAMES J. MARTIN, Cobourg, Ont., 20th September, 1875, for 5 years: "Improvements in Washing Machines." (Perfectionnements aux machines à laver.)

Claim.—The form and construction of the cylinder, and the consequent application of the combination of steam and boiling water applied through the medium of the apertures left in the cylinder, and the change of position of the articles caused by the projections in the cylinder.

No. 5188. CHARLES J. RIPLEY, Cumberland, Ont., 20th September, 1875, for 5 years: "Tag-pin for Vehicle Shafts." (Atteloir de collier de cheval.)

Claim.—The combination of the draw-pin B, having notch C, and chisel pointed end d, and spring E, with the shafts A

No. 5189. TIMOTHY STEBINS, Boston, Mass., U. S., 20th September, 1875, for 5 years: "Hydraulic Elevator." (Élévateur hydraulique.)

Claim.—1st. The wheel E, provided with the buckets e, e, and water tight casing in combination with the port g, provided with the hinge jaw h, for automatically adjusting the flow of water, 2nd The wheel E, and pipe G, provided with the valve I, in combination with the pipe K, four way cock N, exhaust pipe n, cylinder k, piston M, piston rod M1, and brake F1. 3rd. The swinging frame B, provided with the yoke b, and drum A in combination with the levers I, and h1, and automatic port g.

No. 5190. ROBERT S. GALBRAITH, and WILLIAM SNOW, Montreal, Que., 20th September, 1875, for 5 years: "Umbrella and Parasol Case." (Étui de parapluie et de parasol.)

Claim.—1st The combination of the case c, and umbrella or parasol. 2nd. The combination of the cap a, ferule b, case c, ferule d, bush e, and ferule f, 3rd. In the manufacture of umbrella or parasol cases the combination of alternate layers of paper and woven fabric united by cement

No. 5191. JOHN BROKENSHIRE, Kingston, Ont., 22nd September, 1875 (Extension of Patent No. 613), for 5 years: "Improvements on Ships' Pumps." (Perfectionnements aux pompes de navires.)

Claim.—1st. The internal chamber A, in connection with the barrels B, B, the plungers C, C, and the valves D, D, together with the hole or plug H, for sounding, and the opening M, as access to the same and the turn cock L, with pipes K: 2nd. In combination with the above in the construction of the spears or double guides R in connection with the friction-rollers S, S, and eccentrics P, P.

No. 5192. HENRY J. YEARGIN, and WILLIAM KEITH, Liberty, Tenn., U. S., 23rd September, 1875, for 15 years: "Combined Land Roller and Harrow." (Rouleau et herse combinés.)

Claim.—1st. The combination of the main harrow frames A, A1, tongue B, and rear harrow frames C, C1, all hinged and arranged as set forth; 2nd. The combination of frames A, A1, tongue B, frames C, C1, hinged as shown, the extended arms d, and handles d1; 3rd. The combination in a harrow composed of sections hinged together of two independent rolls D, D1; 4th. The combination of the harrow frames A, A1, C, C1, hinged as set forth, the inclined cutting teeth G, G1, and the rolls D, D1.

No. 5193. DAVID W. RAWSON, Croydon, N. H., U. S., 24th September, 1875, for 5 years: "Clothes Washers." (Laveuse à linge.)

Claim.—The combination of the valve V, tube or handle B, expanded foot D, and spiral spring S.

No. 5194. JOHN McBEAN, Chicago, Ill., U. S., 25th September, 1875, for 5 years: "Improvements on Street Pavements." (Perfectionnements dans le pavage des rues.)

Claim.—A street pavement made of stone blocks set in rows and having the spaces between the rows filled with a composition of tar and pitch and pebble gravel or asphaltum and gypsum, or concrete, the whole being covered with a top dressing.

No. 5195. STEPHEN WEBSTER, St. Catharines, Ont., 25th September, 1875, for 5 years: "Oil Tank." (Réservoir à huile.)

Claim.—The application of water up and around the sides and over the top of the inside tank "No. 2," or any part of the sides or top of said inside tank "No. 2."

No. 5196. WALCOTT J. PARMLEE, Herkimer, N. Y., U. S., 25th September, 1875, for 5 years: "Art of Producing Wrought Metal Carriage Axle Boxes." (Art de faire les boîtes d'essieux de voitures en métal forgé.)

Claim.—1st. The shearing dies B, with the top and bottom shoulder b; 2nd. The step dies c, with the single step d, for the formation of a single step d1, in the set metal blanks C; 3rd. The bending dies E, with the semi-circular bends e, and f, for the formation of the bends e, and f, in the stepped blank C; 4th. The combination of the arbour G, the box collar H, and the open die F, by the aid of which the stepped and bent blank C, is welded into an axle box; 5th. The swaging dies J, for the swaging of the small section of the axle box; 6th. The swaging dies Q, with the depressions q, and the arbour N, for the swaging of the larger section of the skelp C; 7th. The combination of the dies J, and Q, operating separately for swaging the axle box; 8th. A sheet or plate metal axle box produced by the combined operations of shearing off a blank from a strip of sheet iron and of stepping, bending, and welding and finally swaging the same at each end separately.

No. 5197. GUSTAV KOLLMEYER, and EDWIN SCHMIDT, Hamburg, Germ., 25th September, 1875, for 5 years: "Improvements on Sewing Machines." (Perfectionnements aux machines à coudre.)

Claim.—1st. Giving the needle bar m, a rocking as well as a sliding motion and the mode of and mechanism for imparting such rocking motion for sewing machines applicable to button hole work; 2nd. The right and left working shuttle C, with straight shuttle race D, parallel to the driving spindle y, in a shuttle machine with one needle; 3rd. The thread brake t, in combination with the shuttle C; 4th. The feed or stitch regulator consisting of the lever l, lever z, screw t, and slot in combination with an eccentric or cam w; 5th. In sewing machine with one needle the right and left working shuttle, the straight shuttle race, rocking needle-bar, thread brake and stitch regulator all combined.

No. 5198. JARVIS HOWE, Milford, Mass., U. S., 25th September, 1875, for 5 years: "Sand Papering Machine." (Machine à papier de verre.)

Claim.—1st. The combination in a sand papering machine of the roll A its shafts J, and spindle D; 2nd. The expanding sand paper roll B; 3rd. The combination of a roll made tapering in the part to be covered with a sand paper tube, whose interior is likewise made tapering to correspond with that part of the roll which it is to cover; 4th. The sand paper tube consisting of a tube of paper or equivalent material covered with a coating of sand or equivalent material; 5th. The roll A, composed of spindle t, washers u, v, wires y, and bends W, W1; 6th. In a sand papering machine, the roll c, with a bearing at only one end.

No. 5199. JOHN D. IMBODEN, Richmond, Va., U. S., 25th September, 1875, for 5 years: "Car Axle Lubricator." (Graisseur d'essieu de wagons.)

Claim.—1st. The detachable spring frame B, for the purpose of holding a lubricating fabric pressed against a car axle journal; 2nd. The leather, rubber or felt shield or cushion to protect the webbing from abrasion and wear at the points of contact with the journal.

No. 5200. HERMAN F. EBERTS, Detroit, Mich., U. S., 25th September, 1875, for 5 years: "Improvements on Wheel-fenders for Vehicles." (Perfectionnements aux garde-crottes des roues de voitures.)

Claim.—The sheet metal wheel fender A, having its edges turned or rolled around a wire strengthening frame B.

No. 5201. ARMAND H. B. BLANCHARD, Montreal, Que., 25th September, 1875, for 5 years: "Improvements on Cloth Measures." (Perfectionnements aux mesures de drap.)

Résumé.—1o. La combinaison de la verge A, et du couteau N; 2o. La combinaison de la verge A, et du porte-cravate E, K, L; 3o. Le système accenseur de latige H, dans le cylindre I; 4o. La combinaison des tiges C, C, glissant dans les croissants D, D, permettant d'avancer et de reculer la verge à volonté.

Claim.—1st. The combination of the rod A and the knife N; 2nd. The combination of the rod A, and of the cravat holder E, K, L; 3rd. The hoisting gear of the rod H, in the cylinder I; 4th. The combination of the rods C, C, sliding in the crescents D, D, permitting the rod to slide backward and forward at will.

No. 5202. MICHEL DURAND, Montreal, Que., 25th September, 1875, for 5 years: "Fire Escape." (Appareil de sauvetage en cas d'incendie.)

Résumé.—1o. L'arrêt à échelons et à ressort-taquet I, avec ses communications g, h, communiquant aux lanchnes t, j, et à la poignée d, alarme W; 2o. Le système d'alarme au moyen de la roue H, et de la lanchnette K, communiquant à la cloche d'alarme Q; 3o. Le frein L; 4o. Le barreau d'embarcation R, avec ses chaînes d'embarcation s, et la grande chaîne T.

Claim.—1st. The tumbler with steps and spring and cleat I, with its communications g, h, with the latches t, j, and the alarm knob W; 2nd. The alarm system by means of the wheel H, and of the latch K, communicating with the alarm bell Q; 3rd. The brake L; 4th. Entrance bar R, with escape chains s, and the large chain T.

No. 5203. GEORGE W. COOK, and EDWARD H. HORSFEL, Chicago, Ill., U. S., 25th September, 1875, for 5 years: "Improvements on Car-trucks." (Perfectionnements aux trains des wagons.)

Claim.—The roller C1, having flange a, journalled in elongated bearing in a frame A1, attached to the car truck, on each side of the car wheels or intermediately in their path.

No. 5204. WILLIAM W. LAMBIE, and JAMES LAMBIE, St. Marys, Ont., 25th September, 1875, for 5 years: "Improvements on Fanning Mills." (Perfectionnements aux tarrares-cribleurs.)

Claim.—1st. The sieve A, having all its holes of the same size but cut for the set apart on the upper portion and gradually coming near together as they approach the lower end; 2nd. The sieve supports F jointed to the head board at B, the vertically adjustable board G, with the fastening bolts K, and the shaker.

No. 5205. SAMUEL S. RYCKMAN (Assignee of P. Mutter), Hamilton, Ont., 15th September, 1875, for 5 years: "Lamp Chimney Cleaner." (Nettoyeur de cheminées de lampes.)

Claim.—1st. The combination of the rubber disc B, or its equivalent with the handle A, attached by rivets C; 2nd. The small disc F, in combination with the handle for cleaning small chimneys.

No. 5206. NORRIS D. MARTIN, and GILMAN W. SEAVER (Assignees of W. Hodgdon), North Troy, Vt., U. S., 25th September, 1875, for 5 years: "Milk Cooler." (Rafraichissoir à lait.)

Claim.—1st. The combination of the overflow pipe E, and exhaust pipe F, having stop cock J, with the vat D; 2nd. Providing the pan C

with feet I; 3rd. The arrangement of the perforated pipe G, within the vat D, opposite to the outlets E, F, in combination with the funnel K; 4th. The combination of the frame A, having legs B, vat D, and pan C.

No. 5207. ALBERT H. WATKINS, Wellesley, Norfolk, Mass., U. S., 25th September, 1875, for 5 years: "Vapour Burner." (Bec à gaz.)

Claim.—1st. The combination and arrangement of the straddling tubes D, D, for supplementary jets with the tube, through which ammonia passes to the burner tube; 2nd. The combination of the shield H, burner tube B, with the gas chamber F, provided with the straddling tubes D, D.

No. 5208. HENRY C. MOODY, Oswego, N. Y., U. S., 28th September, 1875, for 5 years: "Improvements on Children's Carriages." (Perfectionnements aux voitures d'enfants.)

Claim.—The curtains B, B, subdivided vertically, the top secured to the front bow of the carriage, the outer edge running on wires or cords C, attached to the sides whereby the curtains can be raised or drawn laterally and secured by ribbons D, E.

No. 5209. DANIEL GURNEY, Watertown, N. Y., U. S., 28th September, 1875, for 10 years: "Improvements on Milk Coolers." (Perfectionnements aux rafraichisseurs à lait.)

Claim.—1st. In milk coolers, the water tank or vat, provided with a bottom tube or tubes connecting the entrance chamber of the water with any lateral issuing channel at the central part or parts of the vat for distributing the cool water simultaneously over separate sections of the same; 2nd. The end channel *f*, of the vat provided with aperture *g*, for conveying water of section *st* plied from the central issuing channels to exit aperture.

No. 4210. VERFLANCK COLVIN, Albany, N. Y., U. S., 28th September, 1875, for 5 years: "Portable Boats." (Bateaux portatifs.)

Claim.—The blocks A, A, B, B, and prow pieces C, C in combination with a removable and collapsible skin or cover, provided with thongs or their equivalents by which it may be attached to the frame.

No. 5211. ALVARO G. RYKERT, Attica, N. Y., U. S., 28th September, 1875, for 5 years: "Carriage Painter's Jack." (Chèvre de peintre de voitures.)

Claim.—The platform C, constructed in one piece with the pivot pin *c*, the arms *f*, *f*, provided with lugs or teeth *e*, *e*, and arms *f*, *f*, having a slot *g*, adjustable jaw *h* and eccentric lever *i*, all in combination with the socketed sector-wheel B, upright A, spring catch *a*, *b*, and set screw *d*.

No. 5212. GEORGE H. JONES, Rose, N. Y., U. S., 28th September, 1875, for 5 years: "Improvements in Turbine Water Wheels." (Perfectionnements aux turbines hydrauliques.)

Claim.—1st. The water-wheel provided with the buckets having increased depth downward from the concave face of the same; 2nd. The water-wheel bucket provided with a raised dividing edge; 3rd. The combination with a suitable gate of the seat extended in such a manner as will allow the different sized compartments or chambers to be used separately or both simultaneously by the use of a single gate; 4th. The combination with a water-wheel of a syphon draft to be arranged above the same and connected thereto in a manner that will admit of adjustment; 5th. The sliding gate provided with adjustable bearings and other devices by which a portion of the friction of the gate upon its bearing surfaces is converted from sliding into rolling friction.

No. 5213. JOSEPH W. REED (Assignee of M. Van B. Osborn), Kalamazoo, Mich., U. S., 28th September, 1875, for 5 years: "Improvements on Lubricators." (Perfectionnements aux graisseurs.)

Claim.—1st. The combination with the pipe H, I, globe J, and hollow plug K, having supply and discharge orifices of the air openings P, Q; 2nd. The combination with the case A, of the concentric lining C, and intermediate non-heat conducting substance; 3rd. The combination of the pipe K, extending up in the reservoir with the vent P, of the plug K; 4th. The combination of valve T, with plug K, and passage I; 5th. The combination of waste pipe U, with the valve T, and plug K; 6th. The combination of one or more interchangeable plugs V, of different sizes with the hollow plug K.

No. 5214. SAMUEL WILLIAMS and GEORGE S. BRYANT, Boston, Mass., U. S., 28th September, 1875, for 5 years: "Mitting Machine." (Machine à onglet.)

Claim.—1st. The combination of the lever E, and double edged knife F, with the table or bed A, the post B, and the two abutments C, C; 2nd. The combination of the lever E, and double edged knife F, with the table or bed A, the post B, the two abutments C, C, and the guides D, D.

No. 5215. CHARLES L. HOLLAND, Ipswich, Mass., U. S., 28th September, 1875, for 5 years: "Lock-nut." (Noix de sûreté.)

Claim.—In combination with a serrated surface *e*, of the bolt *d*, elastic washer *g*, and serrated nut *f*, or their equivalents.

No. 5216. ROSWELL H. ST. JOHN, Springfield, Mass., U. S., 28th September, 1875, for 5 years: "Sewing Machine." (Machine à coudre.)

Claim.—1st. A take up operated independently of the needle bar; 2nd. The loose cam collar E, with recess *u*, the stop screw *v*, and the gravitating slide J, in combination with the take up arm T; 3rd. The combination of the horizontally divided cross head G, the horizontally divided crank wrist slide *x*, and the adjusting screw *w*, for taking up the wear of the parts; 4th. The ball headed screw *Q* applied to the feed and shuttle driver R, for coupling said driver to the transmitting lever J, and regulating the throw of the shuttle; 5th. The raw hide strip or strips *a*, to reduce friction, wear and noise within the shuttle race; 6th. A shuttle race constructed with dust grooves or depressions; 7th. A shuttle sewing machine adapted to sew in one and the same direction while the shaft is rotated in either direction.

No. 5217. JAMES S. BOGLE, Springfield, Mass., U. S., 28th September, 1875, for 5 years: "Seeding Machine." (Machine à semer.)

Claim.—1st. In combination with a series of flanged distributing wheels, a series of gauges attached directly and rigidly to a rock shaft whereby said gauges are simultaneously operated between the inner periphery of said flanges and the driving shaft for the purpose of gauging the size of the measuring channel; 2nd. The rock shaft F, in rear of the distributing wheel; 3rd. The adjustable gauge *i*, pivoted in rear of the driving shaft its forward end operating behind a stationary flange on the casing plate; 4th. The gauge *h*, provided with slotted or open ends whereby it may be attached to or removed from the rock shaft F, at will without removing the shaft or displacing any of the remaining gauges; 5th. The enlarged run or reservoir on the seed cup conforming at its lower end to the movement of the gauge E, whereby the heel *z*, of said gauge under its various adjustments is kept flush with the curved edge of a and enlarged seed run, thus preventing the grain from crowding in the measuring channel; 6th. The gauge formed as described whereby the form of measuring channel between said gauge and the inner periphery of the flange of the distributor wheel *ri* remain the same under the various adjustments of the said gauge; 7th. The distributor casing provided with the opening in the flange *ci*, to permit the displacement of dirt or other obstructing material that may accumulate on top of the gauge; 8th. The distributor casing provided with the open shaft bearing C₃ for the rock shaft E, permitting the removal or adjustment of the distributors without displacing said shaft; 9th. The spring G₄ in combination with the governing arm G, and pinion I; 10th. The indicator plate K, and spring J, in combination with the shaft I, pinion H, governing arm G, and spring G₂, for adjusting the gauges; 11th. The pendulum slotted bracket H, provided with a bearing for the rock shaft I, in combination with the arm G.

No. 5218. HERRENSTEIN COURTEILLE, New York, U. S., 28th September, 1875, for 5 years: "Improvements on the Manufacture of Blasting Powder." (Perfectionnements dans la fabrication de la poudre à mine.)

Claim.—1st. The combination with peat, charcoal and hard coal, of sulphates of metal; 2nd. The combination with nitrate of soda or saltpetre sulphur and charcoal, of peat, hard coal, sulphates of metal, and oils or fats; 3rd. The process of manufacturing powder by compounding under treatment of direct and externally applied steam of metallic sulphates, peat, charcoal and oils or fats with saltpetre and sulphur, in the manner and in the proportions set forth, whereby the product is made complete while under treatment in mass.

No. 5219. HORACE S. WOLF, South Bend, Ind., U. S., 2nd October, 1875, for 5 years: "Process of Cleansing Gas Retorts." (Procédé de nettoyage des cornues à gaz.)

Claim.—The process of cleansing gas retorts by the use of potatoes.

No. 5220. LAURENS E. DE WARU, Philadelphia, Pa., U. S., 2nd October, 1875, for 5 years: "Improve-

ments on Forming Seams of Boots and Shoes, &c." (Perfectionnements dans la maniere de faire les coutures des chaussures, &c.)

Claim.—1st A seam protected by an outside stay whose edges are turned under and sewed to the leather or fabric by blind stitch seams prior to the formation of the seam of the leather or fabric; 2nd. The method of forming seams in boots and shoes, the same consisting in first stitching the outside stay on the quarters and then sewing together the edges of said quarters. 3rd. The new article of manufacture, the same consisting of a boot, or shoe, the seams of which are protected by outside stays, the edges of which are turned under and sewed to the upper by blind stitch seams.

No. 5221. GREGORY S. THOMPSON, Port Hope, Ont., 2nd October, 1875, for 5 years: "Improvements on Threshing Machines." (Perfectionnements aux machines à battre.)

Claim.—In combination with the cylinder of a threshing machine, the sliding plate C, consisting of a series of curved or straight bars C₂, attached at equal or unequal distances apart, to a cross-head C₁, or its equivalent, the said cross head being provided with one or more rows of teeth D.

No. 5222. JOHN NICKERSON, Simcoe, Ont., 2nd October, 1875, for 5 years: "Milk and Meat Safe Shelf." (Tablette de luterie et de dépense.)

Claim.—The combination of slide-pieces a, a, and movable-bars b, b, b, fitting into the socket C, and slot d.

No. 5223. HENRY A. HOWE, Detroit, Mich., U. S., 2nd October, 1875, for 5 years: "Improvements on Harvesters." (Perfectionnements aux moissonneuses.)

Claim.—1st. A harvester platform so connected with the main frame of a harvester, that it can be swung around behind the latter. 2nd. The eye bolt swivelled in the heel of the shoe and the bearing at the front end of said shoe, in combination with the frame bar connecting it with the main frame of a harvester, and the collar-bearing sleeved in said frame-bar.

No. 5224. ROBERT L. DOWNTON, and JANE A. MILLER, St. Louis, Mo., U. S., 2nd October, 1875, for 15 years: "Middlings Purifier." (Épurateur des gruaux.)

Claim.—1st. The combination with the graded reel A, of two or more air legs E, E₁, in communication respectively with different portions or hoppers D, D₁, of the bolt chest by which the different grades of middlings as delivered from the bolt may be separately purified. 2nd. The combination of the graded reel or bolt A, clothed with different grades of cloth and two or more air legs, each air leg consisting of a series of separating chambers, having at the bottom an inclined passage for the purpose of conducting the material away from the currents of air, and introducing that material at a point above the air inlet in each successive chamber for repurification; 3rd. The combination with the separating chamber I, of the perforated equalizing partition S; 4th. The combination with the fan and the air-pipe M, leading to the dust room, and communicating with the series of separating chambers forming the leg of the setting chamber P; 5th. The combination with the graded reel or bolt A, and sets of separators or air-legs E, E₁, each having a series of separating chambers, of the pipes M, M, fans N, N, and separate dust room O, O; 6th. The combination with the inclined board or plate G, of the slide G₁, to partially close the passage or spout between the chambers I, 7th. The combination with the separating chamber I, of the air openings J, K, at opposite sides and in the lower portion of said chamber spreading board or plate H, and equalizing partition or board S; 8th. The combination with the separating chamber I, of the pivoted slats H, 9th. The combination with the equalizing board or plate S, in chamber I, of the hopper S₁, discharging into said chamber below the said board, 10th. In combination with a vertical series of separating chambers I, forming an air leg E, the pipe M, in communication with said chamber.

No. 5225. ROBERT L. DOWNTON and JANE A. MILLER, St. Louis, Mo., U. S., 2nd October, 1875, for 15 years: "Process of Manufacturing Middlings Flour." (Procédé de préparation de la farine des gruaux.)

Claim.—The process of manufacturing middlings flour by passing the middlings after their discharge from a purifier through or between rolls, and subsequently bolting and grinding the same.

No. 5226. CHARLES B. CLARK, Buffalo, N. Y., U. S., 2nd October, 1875, for 5 years: "Brush, Cloth and Mop Holder." (Manche de brosse, de lavette et de torchon.)

Claim.—1st. In combination with the fixed jaw a, having a slotted screw threaded shank and a nut z, applied thereto, the movable jaw b pivoted within said slotted shank and having the rear end constructed with a lever f, on which the nut z operates so that the end of said lever f will enter the slot by the movement of the nut z, and the latter overlap and enclose the end of said lever f; 2nd. The combined mop and brush holder constructed with the jaws a, b, each of which is formed with a head or rib h, on its inner and outer edges, either or both for strengthening the said jaws a, b, and permitting the latter to be cast comparatively light. 3rd. In a combined mop and brush holder the fixed and pivoted jaws a, b, each constructed with a concave surface k, k, and upper and lower series of teeth f, g, whereby the jaws are strengthened and the mop or the brush is more securely held in position.

No. 5227. HENRY A. WILLIAMS, West Medway, Mass., U. S., 2nd October, 1875, for 5 years: "Machine for Rolling Crimping Tacks, Awls, &c." (Machine à étirer les broches de cambrage, alènes, &c.)

Claim.—1st. The combination of the rollers having the coincident dies or grooves, for forming tacks, &c. provided with the raised notched surfaces forming the sides and edges of said dies or grooves; 2nd. The combination with roller dies A, B, of the feeder S, L, lever M, and cams O, and s. 3rd. The combination of cams U, and W, with lever M, feeder S, L, and the die rollers; 4th. The cams U, and W, arranged in combination with lever M, and its string P, and in relation to cam O whereby the feeder is enabled to shift back on the wire for a new hold. 5th. The grippers a, b, combined with the die rollers and the feeder S, L. 6th. The combination of grippers a, b, cutters X, y, and the feeder S, L, with the die rollers; 7th. The roller housings mounted on ways and provided with an adjusting screw in combination with automatic feed mechanism.

No. 5228. RICHARD D. CHATTERTON, Cobourg, Ont., 2nd October, 1875, for 5 years: "Railway Carriage Coupling." (Attelage de wagons de railroute.)

Claim.—The use of the tumbling catch B.

No. 5229. HELEN M. MACDONALD, Lowell, Mass., U. S., 2nd October, 1875, for 5 years: "Skirt Protector." (Protecteur de jupon.)

Claim.—A skirt protector having a fluted, plated, plain, or other border bound with or composed of enamelled cloth or other water proof material.

No. 5230. FARRELLY ALDEN (Assignee of A. Alexander), Pittsburgh, Pa., U. S., 2nd October, 1875, for 5 years: "Compound Steam Engine." (Machine à deux cylindres.)

Claim.—The combination of the two steam cylinders a, and C, with an auxiliary cylinder b, each supplied with valves, ports, and pistons having a common stem d, the two steam cylinders operating alternately and alternately admitting their exhaust steam into the auxiliary cylinder b to operate the piston therein while their own pistons are balanced by the free circulation of the exhaust steam around them.

No. 5231. WILLIAM H. REED, Chicago, Ill., U. S., 2nd October, 1875, for 10 years: "Gas Carburetter." (Carburateur à gaz.)

Claim.—An air carburetter having a double convolute-wall forming two separate and independent convolute-chambers a, b, inside of a case A, in one of which chambers is an absorbent, and in the other a substance which is a poor conductor of heat.

No. 5232. ISRAEL C. MAYO, Gloucester, Mass., U. S., 2nd October, 1875, for 5 years: "Culinary Boiler." (Marmite.)

Claim.—The combination of the trough B, educt C, boiler A, condenser F, and one or more steaming vessels D, having a perforated cover E.

No. 5233. ERASTUS G. GRAVES, Rome, N. Y., U. S., 2nd October, 1875, for 5 years: "Improvement in Snow Ploughs." (Perfectionnements des charrues à neige.)

Claim.—1st. The wings M, hinged to the rear end of the double mould board E, in combination with the pivoted and longitudinally slotted arms N, N₁, and damping screw S. 2nd. The combination with a tapered shovel-plane A, and an adjustable double mould board E, having the form F, of the vibrating and adjustable arms or rods N, N₁, and set screw S. 3rd. The combination of an incline shovel A, having slot D, and the endwise movable mould-board E, having rock bar e of the pinion G, shaft H, sprocket wheels I, endless belts J, sprocket wheels K, and shaft L.

No. 5234. DAVID MAXWELL, Paris, Ont., 2nd October, 1875, for 5 years: "Improvements on Straw Cutters." (Perfectionnements aux hache-paille.)

Claim.—1st. The longitudinal and horizontal bar F, arranged under the feed box D to support the same and form the lower lip of the mouth of the cutting box D. 2nd. The arrangement of the shaft E under the feed box D, and gear wheels f, g, connecting with the central transverse shaft driving the knife wheel C. 3rd. The flat bent steel spring H applied to depress the upper feed roller d.

No. 5235. CHARLES B. CLARK, Buffalo, N. Y., U. S., 2nd October, 1875, for 5 years: "Lock Hinge." (Penture de sûreté.)

Claim.—In combination with the locking-inclines m, n, ni, ni, the auxiliary locking stop f and recess g, said inclines, stop and recess arranged and operating in conjunction with each other.

No. 5236. BENJAMIN W. THURMAN, Gordonsville, Va., U. S., 2nd October, 1875, for 5 years: "Stump Extractor." (Arrache-Souche.)

Claim.—1st. In a stump extractor, a bisected or divided hinged clamp having spurs or serrations on its inner sides in combination with an extracting mechanism; 2nd. The combination of the long power lever F, the pivoted arm O, the connecting chain B, and the hinged or divided clamp A; 3rd. The combination of the truck hounds F', F', stepped blocks G, G, adapted to be attached thereto, and standards H, H, for adjusting and holding the truck frame.

No. 5237. CHESSER C. HOLMAN, Hamilton, Ont., 2nd October, 1875, for 5 years: "Improvements in Boxes." (Perfectionnements dans les boîtes.)

Claim.—The arrangement and construction of a cubic wood or metal box A, with the tin cover C, perforated with holes a, a, a, and covered by the riveted star F, also the arrangement of the circular box A₁, with circular cover C₁, perforated with holes a₁, a₁, a₁, opened and shut by the riveted and perforated disc D, with projection b.

No. 5238. GEORGE W. COPELAND, Malden, Mass., U. S., 2nd October, 1875, for 5 years: "Improvements in the Manufacture of Boots and Shoes." (Perfectionnements dans la fabrication des chaussures.)

Claim.—The completed shoe made as described, also the series of manipulation producing that result consisting first in removing a thin veneer a, from or scarping a lip a₁, on the upper surface of the insole lasting and the arrangement of the lasting tacks to secure ready removal, laying the welt C, withdrawing the last and permanently uniting the welt C, upper B, and insole A, by a line of wax thread stitches d, laid on the exposed surface of the insole A, caused by turning back the flap a₁, restoring the flap a₁, and cementing it to its original position, again inserting the last and withdrawing the lasting tacks, or if the welt C, and upper B, are attached to the insole A, by a metallic seam, the adjustment and clenching of the same on the exposed surface of the insole A, to be readily curved by the flap a₁, or veneer a, and then in fastening the outside to the welt C, by a line or lines of wax thread stitches d, sewed outside the upper.

No. 5239. RICHARD C. GWATHMEY, Louisville, Ky., U. S., 2nd October, 1875, for 5 years: "Machine for Holding Objects, particularly Cylindrical Ones." (Machine à saisir des objets, surtout cylindriques.)

Claim.—A combination of four bodies or systems of bodies which will be called Applying Bodies, and which in virtue of certain properties size, shapes and position, will be effectual for holding objects particular objects formed with such surfaces as could be imparted by being turned in a lathe, and for other purposes. These properties are as to position; 1st. That the Applying Bodies shall be in relation each to an axis which axis shall be perpendicular to the plane in which the bodies move; 2nd. That these axes shall constitute two pairs; 3rd. That the two constituent axes of each pair shall be fixed relatively to each other; 4th. That the distance between the axes of one pair shall be equal to the distance between the axes of the other pair; 5th. That one or both pairs of axes shall revolve around a point at a finite or an infinite distance; 6th. That a radial line from such point of revolution shall bisect at right angles a line connecting the middle point of a straight line which connects the two of one pair, with the middle point of a straight line which connects the two axes of the other pair, while at the same time the two straight lines connecting such axes shall, if necessary, meet the aforesaid radial line at the same point. The properties as to a size and shape are, 1st. That the four Applying Bodies shall have their sections that lie in same plane perpendicular to their axes, circular around their respective axes, and of the same diameter at least as to such of their surfaces as are applied to objects, 2nd. Any deviation from such size and shape to suit any particular purpose, such modification being available from the relation of the Applying Bodies to the above described axes. And that the objects to be held or acted upon by the Applying Bodies shall be formed in adaptation to the shape of the Applying Bodies to be attached in any way to any machinery that will hold them in the required position and communicate to them the required movement.

No. 5240. FERDINAND ERDMANSKI, St. Louis, Mo., U. S., 2nd October, 1875, for 5 years: "Improvements on Razors." (Perfectionnements aux rasoirs.)

Claim.—1st. The combination of supporting back or frame B consisting of main part B¹, and hinged and fastened to part B² with a detachable symmetrical razor blade C. 2nd. The razor blade C having perforations a, in combination with pin b, of the lower main part B¹, and recess b¹, of the top part of supporting frame B, for the purpose of securing steady position of blade.

No. 5241. RICHARD D. CHATTERTON, Cobourg, Ont., 2nd October, 1875, for 5 years: "Improvements in the Construction of Railway Carriage Draw-Bars and Springs." (Perfectionnements dans la confection des ressorts de choc et de traction des voitures de rail-route.)

Claim.—1st. The wedge draw or buffing bar A, of a railway carriage in combination with levers B, B, bearing upon springs C, C, adapted so as to increase their power and range; 2nd. The prolongation of the buffing bars A, of a railway carriage by a connecting rail or bar H, between them so as to produce the immediate transmission of the shock of a collision to the buffing bar of the next adjoining carriage.

No. 5242. JOSEPH H. KILLEY, and WALTER MURHEAD, Hamilton, Ont., 2nd October, 1875, for 5 years: "Improvements in Steam Boilers." (Perfectionnements dans les chaudières à vapeur.)

Claim.—1st. In combination with the horizontal tubes C, of a boiler, the arrangement of the vertical tubes D, as shown, provided with the openings F, near the bottom; 2nd. The manner of securing the tubes D, by means of the wire G, 3rd. In combination with the boiler A, the steam pipe H, or coil of pipes perforated with holes b, &c., the central one connected with the dome for taking the steam from the boiler 4th. In combination with a steam boiler A, the arrangement of the scum pipe I, perforated with hole d, &c. terminating with the taps J, J, for removing scum from the boiler; 5th. In combination with a steam boiler A, the arrangement of the wind ejecting pipe K, placed near the bottom of the boiler perforated with holes e, e, &c., the pipe terminating with the taps L, L, outside the boiler; 6th. In combination with a steam boiler A, the peculiar arrangement of the fire-bars M, consisting of the alternate bevelings f, on each side cut down from the top to the line z, z, forming corrugations or air passages for the greater admission of air, also the hollow bearings g, g.

No. 5243. WILLIAM H. REED, Chicago, Ill., U. S., 2nd October, 1875, for 10 years: "Air Blower for Carbureters." (Machine à produire un courant d'air dans les carburateurs.)

Claim.—1st. In an apparatus for supplying air regularly to gas carbureters, the helical flange C, provided with web a and case B, combined with the case A, having an induction-passage g and an induction pipe E, and rotated as described; 2nd. The helix C, having web a, in combination with the perforated shaft D, and case B, open at one end.

No. 5244. LOUIS P. BRUNELLE, and SIGISMUND MOHR, Quebec, Que., 5th October, 1875, for 5 years: "Gravity-Battery." (Batterie de gravité.)

Claim.—1st. The combination of the cylinder E, made of glass or other material, having perforations c, in its lower part forming the feeder G, and the central residue-zinc-receiver F, independent of or attached to the cylinder E, with a gravity-battery, 2nd. The combination of the two vertical zincs B, C, admitting the perforated cylinder E, in their middle, with a gravity battery, 3rd. The combination of the copper coil-plate D, surrounding the perforated part or feeder G, of the cylinder E, with a gravity-battery.

No. 5245. NATHANIEL W. WESCOTT, and CHARLES L. SPENCER, Providence, R. I., U. S., 5th October, 1875, for 15 years: "Knitting Loom." (Métier à tricoter.)

Claim.—1st. The combination with the latch-needles C, of a knitting-loom of the internal dividing wheel G, and external latch-guard M, 2nd. The combination with the latch-needles C, and the "cam-rise" in casing E, of the latch-guard M, 3rd. The combination with the latch-needles C, of the external-latch-guard M, the external-wheel H, and the internal dividing-wheel G: 4th. The combination with the latch-needles C, and "cam-rise," of a knitting-loom of the dividing wheel G, and the adjustable web-guide F; 5th. The pockets e, at the upper-ends of the needle-grooves in cylinder C in combination with wheels G, H, 6th. The combination with the latch-needles C, and "cam-fall," of a knitting-loom of the adjustable guide L, pressure burr O, and wheels G, H, 7th. The adjustable latch-guard M 8th. In combination with the trumpet shaped thread-guide F, the flange I, perforated, 9th. The relative arrangement of the guide F, with respect to the "cam-rise," for the needles in combination with wheels G, H: 10th. The grooved latch-needle carrying cylinder C, bevelled at d.

No. 5216. GEORGE W. COPELAND, Malden, Mass., U. S. (Assignee of F. D. Ballou), 5th October, 1875, for 5 years: "Boot and Shoe Wax Thread Sewing Mechanism." (Machine à coudre les chaussures au fil ciré.)

Claim.—The shaping of the table A, which supports the work at the place where the feeding and sewing mechanism operates as a mere elevated projecting exterior and interior work support B, not continued beyond the exterior wall a, of the throat in which the stitching and feeding mechanism operates sufficiently to impede the turning of a shoe horizontally, in stitching round the outside of the upper, an elevated work-support B, located at or near the edge of the work plate A, and forming a thin wall a, to the needle-throat higher than the depth of the channel in the sole with or without the shield a₂ and of such size, in plan, that the work of the machine it is lapped to the depth of the channel by the sides of the channel, the presser foot G, when constructed and arranged, and used as a guard or guards and gauge, the combination of the presser-foot G, with the elevated projecting work-support B, when arranged to guard and guide the work as the sewing and feeding proceeds, the combination of a sewing and feeding mechanism working in a throat surrounded by an elevated projecting work-support B, a short and narrow exterior work-support forming the exterior wall a₂ of the needle-throat extended beyond the throat merely sufficiently to connect the exterior work-support with the fixed parts of the machine, and so shaped as not to interfere with the turning of the shoe horizontally or inclining the same in stitching around and through the outer margin of the sole and an interior work support, forming the interior wall of the elevated throat the arrangement, combination and location of the presser-bar H, and foot G,awl E, and awl bar needle F, and needle-ber, and feeding device in connection with an elevated projecting-throat B, and work-support A, in relation to each other and in relation to the work to permit the sewing around and through the outer margin of the sole, and the consequent turning and inclining of the shoe freely and without interference with the sewing-mechanism or frame work of the machine

No. 5247. ROBERT ALDRED, Glencoe, Ont., 5th October, 1875, for 5 years: "Rail-Road Track Lifting Machine." (Machine à lever les voies de railroutes.)

Claim.—A frame constructed of wrought iron in combination with two screws B, B, supported by two-pivoted-nuts C, C.

No. 5248. SAMUEL R. SMITH, and JOSEPH SIMPSON, Manchester, Eng., 5th October, 1875, for 5 years. "Improvements on Production and Manufacture of Iron, Steel, and other Metals, and on the Apparatus and Compounds employed therein." (Perfectionnements dans la production et la fabrication du fer, de l'acier et autres métaux, et dans les appareils et les composés pour cet objet.)

Claim.—1st. The production purification and refining of iron, steel, and other metals. 2nd. The process called our Great Force process; 3rd. The apparatus to carry out our Great Force process; 4th. The process called our Liquid process; 5th. The apparatus to carry out our Liquid process; 6th. The process called our Retort Generating process; 7th. The apparatus to carry out our retort generating process; 8th. The refining of iron and other metals, and the manufacture of steel in our trunion ladle; 9th. The apparatus called our Trunion Ladle; 10th. The refining of iron and other metals and the manufacture of steel in our metal receiver; 11th. The apparatus called our metal receiver; 12th. The pipe or pipes descending into the metal; 13th. The smelting and melting of iron and other ores by means of our vacuum or exhaust furnace; 14th. The furnace called our vacuum or exhaust furnace; 15th. The smelting and melting of iron and other ores, and the purification thereof as well as the manufacture of steel by means of our vacuum or exhaust furnace when combined with the chamber and descending-pipes; 16th. The furnace called our vacuum or exhaust furnace when used not only for the smelting and melting of iron and other ores, but also for the purification thereof as well as for the manufacture of steel; 17th. The combination of our great force process either with our trunion-ladle or our metal receiver or our vacuum or exhaust-furnace; 18th. The combination of our liquid process (with or without the retort-oven used as a heater) either with our trunion-ladle or our metal-receiver or our vacuum or exhaust-furnace; 19th. The combination of our retort generating-process either with our trunion-ladle or our metal-receiver or our vacuum or exhaust-furnace; 20th. The apparatus called our heating annealing and balling retort-oven furnace; 21st. The apparatus called our retort puddling-furnace; 22nd. The refractory-materials decomposed; 23rd. The several modes of using gaseous-compounds as purifier; 24th. The several modes of using gaseous compounds for heating-purposes.

No. 5249. FRANÇOIS X. BELLEFEUILLE et ACHILLE BELLEFEUILLE Trois-Rivieres, Qué., 5th Octobre 1875, pour 5 ans: "Grain Threshing Machine." (Machine à battre les grains.)

Résumé. 1. La charpente A; 2o. Le lit E; 3o. La combinaison avec la charpente A la toile G; 4o. La combinaison avec le porte-paille L, de la toile G; 5o. Le soufflet K; 6o. La combinaison de la charpente A, tambour B, lit E, toile G, porte-paille L, soufflet K, et porte-passe M.

Claim.—1st. The frame work A; 2nd. The bed E; 3rd. The combination of the framework A, with the sheet G; 4th. The combination with the straw carrier L, G, the sheet G; 5th. The blower K; 6th. The combination of the frame work A, drum B, bed E, sheet G, straw carrier L, blower K, sieve frame M.

No. 5250. LORENZO DILL, Greenville, Ohio, U. S., 5th October, 1875, for 5 years: "Car Coupling." (Atelage de wagons.)

Claim.—The combination of the coupling bar D, the pivoted and forked swing-bar E, and the draw-head A.

No. 5251. ROBERT D. ROBBINS, Port Perry, Ont., 5th October, 1875, for 5 years: "Improvements in Mowing and Reaping Machines." (Perfectionnements dans les faucheuses-moissonneuses.)

Claim.—1st. In constructing a reaping and mowing machine in which the cutter bar O, is placed in the centre-line of the axle C; 2nd. The shaft G, and spur nitre pinion I, in combination with the spur nitre pinion L, and shaft I; 3rd. The crank-wheel M, with wrist-pin F, in combination with the slotted-heel R, and knife Q; 4th. The swing-bar J, with branched ends hinged on to the over hanging-box H, and pin d, in combination with the shaft L, and cutter bar O, with all the gearing connected thereto; 5th. The shoe P, hinged on the swing box N, and bracket T, in combination with the keeper-plate p, and cutter bar O; 6th. The tongue X, hinged on the axle C, and passing through a vertical slot in the frame A, so as to allow the machine to work independently of the tongue, and thus permit the automatic raising and depressing of the cutter-bar O.

No. 5252. EDWARD D. HARGREAVES, Sarnia, Ont., 5th October, 1875, for 5 years: "Railway Car Ventilator." (Ventilateur de voiture de railroutes.)

Claim.—The combination and arrangement of belting or gearing B, axle A, pipes E, openings F, exhaust fan D, with the railway car.

No. 5253. THOMAS HARVEY, and ALEXANDER HARVEY, London, Ont., 5th October, 1875, for 5 years: "Dumping Wagon." (Wagon à bascule.)

Claim.—1st. The wagon-box G, C, with movable bottom pieces A, A, pivoted at ends B, B, B, B; 2nd. In combination with the above the bars F, H, pin J, chain K, handle L, brace D, and tie-rod E.

No. 5254. PARLEY J. AYRES, Lindsay, Ont., 5th October, 1875, for 5 years: "Portable Buggy Top." (Soufflet de voiture mobile.)

Claim.—The arrangement of the tapered-socket B, in combination with the tapered pin, the connection of the anvil rib by the socket E, and elastic band and brace F.

No. 5255. HUGH SELLS, Vienna, Ont., 5th October, 1875, for 5 years: "Cider Mill." (Moulin à cidre.)

Claim.—1st. The combination of the pinion and lever K, K₁, the standards L, L, plate d, and wedge e, with the press-bar l, provided with the rack b, and its guide j, on the cross-piece A₁; 2nd. The revolving face-plate D, of iron with the wooden-disc E attached thereto with metal studs, or teeth as a grinder, in combination with the hopper, so arranged as to force the apples against the revolving wooden-disc E.

No. 5256. SAMUEL L. PORTER, and DUANE PECK, Rochelle, Ill., U. S., 5th October, 1875, for 15 years "Railway Rail Support." (Coussinet de railroute.)

Claim.—1st. A metallic railway tie constructed of symmetrically arranged bed-pieces or supports connected by diagonal braces; 2nd. The bed plate or rail support A, provided with lugs or ledges D, at both sides of the rail in combination with locking plate E, key F, set screws f, and the rails C; 3rd. The bed plate having slotted bolt orifices in combination with the rail and fastening screw bolts having projecting disc heads and nuts to be tightly applied to the rail base; 4th. The bed plate provided with bolt orifices, having a square nut orifice and diagonal extension slot.

No. 5257. NIKOLAS YAGN, St. Petersburg, Russia, 5th October, 1875, for 5 years: "Improvements on Feeding Apparatus of Steam Boilers." (Perfectionnements aux appareils d'alimentation des chaudières à vapeur.)

Claim.—1st. The self-acting apparatus for feeding steam boiler with water consisting of two reservoirs R, and R₁, placed one above the other and separated one from the other by an intervening non-conductor

of heat O, which reservoirs are communicating with each other by means of pipes B, C, and d, with the steam boiler D, by pipes E, and G, provided with valves I, and K, and with a well or cistern by the pipe A, provided with one or more valves F; 2nd. In the combination with the steam boiler D, of the aforesaid apparatus for feeding the same automatically and periodically in proportion to the dispense of water in the said boiler, the upper reservoir R, being completely filled with cold water up to the moment when a due vacuum is produced in the apparatus respectively sucking the water from the well or cistern periodically and instantaneously by the pipe A, whilst in the lower reservoir R, a periodical and momentaneous condensation of steam takes place at the very moment when this reservoir is emptied from water, and the cold water enters suddenly in it from the upper reservoir R, the influx of steam from the boiler not being interrupted; 3rd. The combination with the lower reservoir R, of the pipe G, provided with a screw tap or sliding valve K, constantly more or less open for the entry of the steam from the boiler into this reservoir; 4th. The combination with the orifice of the pipe B, in reservoir R, of an obturator or valve S, provided with a float T; 5th. The combination with the reservoir R, of a float W, which float may be replaced by one or more perforated partitions n; 6th. The combination with the reservoirs R, and R₁, of the tubes A, B, C, and d; 7th. The combination with the reservoirs R, R₁, of the pipe B, provided with partitions z, z.

No. 5258 JOHN SHIRREFF, Chatham, N. B., 5th October, 1875, for 5 years: "Improvements on Freezing and Refrigerating Machines." (Perfectionnements aux appareils rafraichisseurs congelateurs.)

Claim.—1st. The arrangement and combination of a vertical freezing and preserving chamber or chambers C, placed in and in combination with a main or outer freezing and preserving chamber A; 2nd. The arrangement and combination of vertical tubes G, in connection with vertical chamber C; 3rd. The doors O, in connection with the vertical chamber C; 4th. The thermometer P, in connection with doors O; 5th. The horizontal pipes J, siphon pipes K, and T; 6th. The arrangement of stoppers L, to tubes G; 7th. The arrangement of one or more vertical chamber C.

No. 5259. JOHN S. ROGERS, Gloucester, Mass., U. S., 5th October, 1875, for 5 years: "Art of Extracting Gelatine from Salted Fish Skins." (Art d'extraire la gelatine des peaux de poisson sale.)

Claim.—The process of treating salted fish skins for the procuring of their gelatine, such consisting in certain specified steps, to wit, soaking and agitating them in cool water so as to desalt and descale them and afterwards boiling them in fresh water, and removing superfluous matters therefrom and finally straining or filtering the gelatinous solution and if need be evaporating it to or partially to dryness.

No. 5260. DANIEL HAWKESWORTH, Digby, N. S., 5th October, 1875, for 5 years: "Spark Arrestor." (Arrete flammeche.)

Claim.—A cylinder A, having a series of internal triangular plates a, a, arranged circumferentially and spirally, overlapping each other sidewise and at the points.

No. 5261. DAVID STEELE, Hamilton, Ont., 5th October, 1875, for 5 years: "Improvement on Apparatus for Extinguishing Fires." (Perfectionnements aux extincteurs d'incendies.)

Claim.—1st. An arrangement of perforated water pipes for outside protection laid above the parts of buildings, &c., to be protected from fire connecting with a stand pipe having cocks set in suitable places for shutting off the water from any desired section of the system; 2nd. A combination for inside protection consisting of a perforated metallic ceiling and a supply pipe whereby the water is distributed and directed in the form of a shower bath; 3rd. In combination with the perforated ceiling F, and supply pipe A, a metallic water tight sub-floor secured to the joists having an eduction pipe for carrying off the doused water.

No. 5262. PETER WOOD, Uxbridge, Ont., 5th October, 1875, for 5 years: "Shaft-coupling for Cutters." (Ajutage des limonieres de traveaux.)

Claim.—1st. The combination of the collared staples, one being attached to shafts, and the other attached to cross-bar on cutter; 2nd. The combination of the two slotted eyes, one being attached to cross bar on the cutter and collared staple on the end bar on shafts, and the other attached to end bar on shafts and collared staple on cross bar on cutter; 3rd. The combination of the collared slotted eyes and retaining knobs.

No. 5263. IONATIUS HAHN, Pittsburgh, Pa., U. S., 5th October, 1875, for 15 years: "Hydraulic Crane." (Grue hydraulique.)

Claim.—1st. The combination of the crane post jib and frame, the crane post being hinged to the frame so that the jib and post travel together in a vertical plane around a common axis; 2nd. The combina-

tion of a crane post, its supporting stand or frame and suitable mechanism for raising an iron erige the post and its load, the post being connected to its stand by a hinge joint or connection and the power for raising and lowering the post being applied directly thereto; 3rd. In combination with a crane post hinged to its stand or frame an oscillating cylinder and piston, the piston acting upon the post to raise and lower the same; 4th. In combination with a crane post hinged to its stand or frame, an oscillating cylinder and piston acting upon the post to raise and lower the same and an annular cylinder and piston for raising and cushioning the post; 5th. In combination with the crane post and the piston and cylinder for raising the post upon its vertical pivot, a vertical rod and cross arm or mechanism for adjusting and preserving the level of the cylinder; 6th. The combination of the crane post, its frame or stand, the oscillating cylinder for operating the post and a single pair of supporting wheels, the several parts being relatively arranged so that the points of support centre of trunnions and fulcrum are in a vertical line whereby the weight of the load is transmitted directly to the ground.

No. 5264. ALEXANDER BETTES, Warrensburgh, Mo., U. S., 5th October, 1875, for 5 years: "Heating Stove." (Calorifere.)

Claim.—1st. The combination of the oval or nearly cylindrical exterior case A, the plain lining or inner wall B, arranged parallel thereto, and provided with flanges C, C, to form the smoke flues, and having an opening D, on each side of the stove at the rear end of the combustion chamber H; 2nd. The oblique diaphragms E, cut out at F, forming the side flues, in combination with the vertical flue J, joined to, and forming an integral part of the case, or independent, and the openings K, L, the latter provided with a valve X.

No. 5265. THOMAS KANE, Hamilton, Ontario, 11th October, 1875, for 5 years: "Coal Ash Sifter." (Tamis à cendre de charbon.)

Claim.—1st. In combination with a barrel A, or other equivalent receptacle, the arrangement of the half circular sieve H, constructed as shown, made to revolve in the said barrel, &c.; 2nd. In combination with the barrel A, or other receptacle, the arrangement of the cover B, provided with the block E, rim D, handle F, and opening O; 3rd. The arrangement of securing the sifter or sieve H, with the handle F, by means of the rod G, metallic pieces K, L, and nut M.

No. 5266. FRANCOIS X. BELLEFEUILLE, and ACHILLE BELLEFEUILLE, Trois-Rivières, Que., 11th October, 1875, for 5 years: "Horse-power." (Manège à cheval.)

Résumé.—1o. La charpente ayant les poteaux B, B₁, B₂, et B₃, et munie de la pièce horizontale C, et de la pièce transversale M, 2o. L'arrangement en dedans de la charpente de tout l'engrenage; 3o. La combinaison dans une seule roue F, de la roue à chaîne et de la roue d'engrenage F.

Claim.—1st. The frame works, having the post B, B₁, B₂, and B₃, and furnished with the horizontal piece C, and the transverse piece M; 2nd. The arrangement inside of the framework of all the gearing; 3rd. The combination in a single wheel F, of the chain wheel and gear wheel F.

No. 5267. EDSON FITCH, and LEWIS H. HAMILTON (Assignees of G. R. Clark), New Liverpool, Que., 11th October, 1875, for 5 years: "Paper Match Box Machine." (Machine à boîte d'allumettes en papier.)

Claim.—1st. In combination with the frames A, the receiver a, rods b, b, guides c, rod d, lever e, shaft f, cam D, lever g, roller h, and spring i; 2nd. In combination with the frame A, the lever E, shaft j, cam F, lever k, shaft l, roll r, m, rod n, and lever o; 3rd. In combination with the rollers q, the frame r, shaft s, enlargement t, cam G, and roller u; 4th. The revolving plate p, and shaft r, in combination with the clip g₁, pin h₁, and dogs v; 5th. In combination with the shaft v₁, the plate w, pins x, bar y, frame z, grooves a₁, catches b₁, and springs c₁; 6th. In combination with the bar y, the lever d₁, rod e₁, shaft l, roller f₁, and cam F; 7th. In combination with the frame A, and standard j₁, the plate k₁, movable plate l₁, bar m₁, cam D, lever n₁, and rod o₁; 8th. In combination with the standard j₁, the bar p₁, lever q₁, spring r₁, and fork s₁; 9th. In combination with the frame work A, the guide H, die t₁, lever u₁, links v₁, shaft w₁, cam G, lever z₁, roller y₁, rod z₁, and lever a₂; 10th. The combination of the die t₁, with the dies b₂, c₂, d₂ guides e₂, cam k, levers f₂, and g₂, shaft h₂, rollers i₂, and j₂, and rods k₂, and l₂; 11th. In combination with the table A, the bars m₂, blocks n₂, and o₂, hinge p₂, plates q₂, springs r₂, lever s₂, shaft l, enlargement r, and cam k; 12th. The combination of the roller frame c, with the snugs u₂, forks v₂, rollers w₂, bands z₂, and springs z₂; 13th. In combination with the roller frame c, the cam G, roller a₃, lever b₃, rod c₃, and snug d₃; 14th. In combination with the table B, the bar m₃, wedges e₃, lever f₃, rod f₃, bell crank g₃, rod h₃, forks v₃, rollers i₃, bands z₄, and fixed piece k₃.

No. 5268. CHARLES Z. MATTISON, and GEORGE W. SHAW, St. Louis, Mo., U. S., 11th October, 1875, for 5 years: "Spinning Machine." (Rouet.)

Claim.—1st. The combination of the wheels C, F, and G, when the wheels F and G, vary as to the numbers of teeth, and are connected respectively with the bobbin and fler frame so as to give positive rotation to both and at different speeds; 2nd. The combination of cog wheels

O, and P, a shaft Q, with cog barrel or wheels Y, and W, and cam R, 3rd. The combination of the cog wheels O, and P, screw shaft Q, Qr, thread carrier a, b, with split nut engaging the shaft wheels W, and Y, and cam R; 4th. The provision in a spinning machine of a bobbin so arranged that it can be reversed for doubling and twisting.

No. 5269. EDWARD BALREMA, and HENRY BEUMER, Lafayette, Ind., U. S., 11th October, 1875, for 5 years: "Waggon Axle." (Fessieu de wagon.)

Claim.—1st. An axle adapted to turn in boxes, combined with a thimble-skein adapted to turn upon the thimble so that there is an independent revolution of the axle and of the traction wheels; 2nd. In combination with an axle, a box in which it is to revolve, and thimble-skains capable of revolution upon a thimble rigidly attached to said axle.

No. 5270. GEORGE MEACON, Beverly, Mass., U. S., 11th October, 1875, for 5 years: "Catamenial Sack." (Garni.)

Claim.—1st. In combination with the outer-sack a, and the inner-sack b, of the rounded edge d, elastic lip e, and porous band or welt f; 2nd. In combination with the outer-sack a, and the inner-sack b, of the central front and rear-bands g, h, and the side-bands i, j, k, k, for attachment around the limbs.

No. 5271. ALBRECHT E. BARTHEL, Detroit, Mich., U. S., and WILLIAM SMITH, Toronto, Ont., 11th October, 1875, for 5 years: "Peat Machine." (Machine à tourbe.)

Claim.—1st. The process for the preparation of peat for fuel consisting in placing the green-peat within a grinding mill A, from which it falls when ground into a hopper B, leading into a revolving screen C, which separates the fine peat from the coarse substances therein, the former falling through the screen into the buckets of the elevator D, from which it is discharged by the spout E, on to the top drying pan F, within the kiln I, heated by the steam-pipes H, the worms G, revolving within the pan F, convey the peat to its opposite end when it falls over on to the pan beneath and the worms G, therein repeat the operation till the lower pan is reached from whence the peat is propelled into the pressing machine J, by the revolving worm H, the whole arrangement of parts being such that no manual labour is employed from the time that the peat enters the grinding mill A, till it is discharged from the pressing machine J; 2nd. The double bottom pans E, with revolving worms G, arranged one pan above the other within a kiln I, in combination with the steam pipes H, 3rd. Drying peat by passing it through a drying kiln, and pressing it while yet hot into a continuous stream; 4th. The head block p, pivoted on p, in combination with the screw p', for the purpose of contracting the channel q, 5th. The plunger r, having a reciprocating motion in combination with the channel q.

No. 5272. CALVIN L. FISHER, Spring, Pa., U. S. 20th October, 1875, for 5 years: "Improvements in Side-spring Vehicles." (Perfectionnements dans les voitures à ressorts de côté.)

Claim.—1st. The elastic braces J, J and K, K, and their application to side-spring vehicles, 2nd. The combination of side-springs E, constructed with a scroll e, on one or both ends with axles A, and B, platform or box H, and elastic self-adjusting braces or reaches J, J, and K, K, 3rd. The platform or box H, and its combination with the elastic braces J, J, and K, K, springs E, and axles A, and B.

No. 5273. ALEXANDER WORSTER, Groveton, N. H., U. S., 20th October, 1875, for 5 years: "Locking Latch." (Loquet-serrure.)

Claim.—The combination of a locking bolt provided with two arms D, and H, forming an obtuse angle on the under or lower side, as shown in the drawings, and provided with a pin a, and notch f, the fixed pin d, the spring F, and the latch C, provided with the pin b, and operating on the pivot f, near its centre, together with the semi-circular cam E, operating by means of the usual knob and shaft on the upper rear extremity of the latch C.

No. 5274. WILLIAM F. NEAL, Liberty, Me., U. S., 20th October, 1875, for 5 years: "Horse Hay Rake." (Rateau à cheval.)

Claim.—1st. The tooth support bars C, as forked at their front ends, or parts connected with the axle by means of a rod and eye bolts; 2nd. The combination of the bar C, forked at its rear part, with two teeth g, g, (pivoted to the prongs of the fork) and with a duplex brace J, applied to such bar and teeth; 3rd. The combination of the connector bar f, with the swinglo tree G, and the axle A, the said bar being applied thereto and the thills D; 4th. The combination of two or other suitable number of clearers R, R, with the thills D, and the rake head or axle A, provided with the tooth support bars C, 2nd teeth g; 5th. The combination of the slotted adjustable slides c, c, and their clamp screws d, d, with the thills D, and the rake head or axle A, its tooth bars C, and teeth g; 6th. The duplex brace J, provided with the loops j, j, and the eye k, for application to the two teeth g, and their carrying bar C.

No. 5275. AUGUSTUS CORNELL, Bosanquet Ont., 20th October, 1875, for 5 years: "Quilting-frame." (Métier à piquer.)

Claim.—1st. The movable bar B, which slides on the rollers A, A, 2nd. The hooks attached to the movable bar B, and to the piece C.

No. 5276. GEORGE B. THURBER, Upton Station, Que., 20th October, 1875, for 5 years: "Oscillating Steam Engine." (Machine à vapeur oscillante.)

Claim.—1st. A stationary valve D, with waste boxes W, and live steam and exhaust ports E, and Et, and S, having their openings in the concave face of the valve, by means of which live steam is supplied and exhaust steam received from the cylinder, at the proper time by its oscillation, 2nd. A cylinder with a convex face in the form of a segment of a circle, having its centre in common with the supporting trunnions passages a, and b, so arranged that they will receive and exhaust steam at the proper time by the oscillation of the cylinder. Also the lubricating chambers L.

No. 5277. JAMES HARRIMAN, Thorold, Ont., 20th October, 1875, for 5 years: "Tumbling Rod and Coupling Joint Covering." (Chemise de tige à joint universel.)

Claim.—1st. The coupling joint covering composed of the cylindrical sections A, D, and F, fitting and held together to form a ball joint casing, 2nd. The ball joint casing having on the outer ends polygonal formed rings G, 3rd. The sectional covering for tumbling rod composed of board H, and polygonal rings I, fitting endwise together.

INDEX OF INVENTIONS.

Acids, carrier for, F. H. Kalbelsch..... 5185
 Awns, crimping tools, &c., machine for rolling, H. A. Williams..... 5227
 Axle boxes, art of producing wrought metal carriage, W. J. Parmlee..... 5190
 Barrel or circular box, F. B. White..... 5172
 Boat, portable, H. Calvin..... 5210
 Bolts, dies for heading and squaring, J. B. Clark..... 5177
 Boot and shoe wax thread sewing mechanism, G. W. Copeland..... 5216
 Boots and shoes, G. W. Copeland..... 5238
 " " forming seams of, L. E. De Waru..... 5220
 " " "..... 5237
 Box, C. C. Holman..... 5153
 Bristle and fibre combing machine, G. Boeckh..... 5226
 Brush, cloth and mop holder, C. B. Clark..... 5251
 Buggy, top portable, P. J. Ayres..... 5199
 Car axle lubricator, J. D. Imboden..... 5203
 " trucks, G. W. Cook and E. H. Horsey..... 5270
 Catamental sack, G. Moseon..... 5176
 Cement pipes, wells and drains, J. Regan..... 5203
 Children's carriages, H. C. Moody..... 5157
 Churn power, J. Guest, Jr..... 5255
 Cider mill, H. Sells..... 5265
 Coal ash sifter, T. Kane..... 5277
 Coupling joint covering and tumbling rod, J. Harriman..... 5263
 Crane, hydraulic, I. Hahn..... 5227
 Crimping tools, awls, &c., machine for rolling, H. A. Williams..... 5183
 Cullinary apparatus, G. H. Bliss..... 5232
 " boiler, I. C. Mayo..... 5239
 Cylindrical objects, machine for holding, R. C. Gwathmey..... 5176
 Drain, cement pipes and wells, J. Regan..... 5163
 Drive chain, W. D. Ewart..... 5244
 Electric battery, gravity, L. P. Brunelle and S. Mohr..... 5204
 Fanning mill, W. W. and J. Lambie..... 5182
 " " J. W. Johnson, C. M. Manville, S. W. Alvard, E. E. Buffington, L. B. Rodgers, E. R. Myer, I. Vosburg and G. F. Nichols..... 5168
 Fatty matter from cereals, &c., A. Mambre..... 5161
 Feather renovating machine, G. Kelly..... 5153
 Fibre and bristle combing machine, C. Boeckh..... 5180
 File and tool handle, W. R. Fenerty..... 5202
 Fire escape, M. Durand..... 5261
 " extinguisher apparatus, D. Steele..... 5169
 " kindler, J. Commins..... 5225
 Flour, manufacturing middlings, R. S. Downton and J. A. Miller..... 5161
 Forks and shovels, lifting attachment for, F. M. Gardner..... 5176
 Framing and moulds to make wells, cement pipes, &c., J. Regan..... 5258
 Freezing and refrigerating machine, J. Shirreff..... 5231
 Gas carburetter, W. H. Reed..... 5213
 " air blower for, W. H. Reed..... 5154
 " illuminating, J. H. Sheldon..... 5219
 " reports, process of cleansing, H. S. Wolf..... 5259
 Gelatine, extracting from salted fish skins, J. S. Rodgers..... 5165
 Guitar head, H. W. White..... 5223
 Harvester, H. A. Howe..... 5192
 Harrow and land roller, combined, H. J. Yeargin and W. Keith..... 5171
 Heating apparatus, steam, I. C. Richardson..... 5170
 Hoop machine, A. F. Skidmore..... 5155
 Horse, apparatus to prevent from jumping, G. H. Thompson, A. A. Mathews and M. O. Mathews..... 5271
 " hay rake, W. F. Neal..... 5266
 " power, F. X. and A. Bellefeuille..... 5189
 Hydraulic elevator, T. Stebins..... 5218
 Iron, steel, &c., manufacture, apparatus and compounds for production of, S. R. Smith and J. Simpson..... 5211
 Jack, carriage-painters, A. G. Rykert..... 5171
 " hydraulic, E. Reddle..... 5215
 Kitting loom, M. W. Westcott and C. L. Spencer..... 5158
 Ladder, extension, R. Gilchrist..... 5205
 Lamp chimney cleaner, S. S. Rickina..... 5192
 Land roller, and harrow, combined, H. J. Yeargin and W. Keith..... 5273
 Latch, locking, A. Worster..... 5162
 Leather crimping machine, C. B. Long..... 5255
 Lock hinge, C. B. Clark..... 5213
 Lubricator, J. W. Reed..... 5267
 Match box (paper) machine, L. H. Hamilton..... 5291
 Measures, cloth, A. H. B. Blanchard..... 5224
 Middlings, purifier, R. L. Downton and J. A. Miller..... 5296
 Milk cooler, N. D. Martin and G. W. Seaver..... 5209
 " " D. Gurnsey..... 5222
 " and meat safe shelf, J. Nickerson.....

Mill stones, producing cold air round, G. Walling..... 5186
 Mitring machine, S. Williams and G. H. Bryant..... 5170
 Moulds and framings to make wells, &c., J. Regan..... 5251
 Mowing and reaping machine, R. D. Robbins..... 5215
 Nut, lock, L. C. Holland..... 5195
 Oil tank, S. Webster..... 5271
 Peat machine, A. E. Barthel and W. Smith..... 5178
 Potato digger, H. Bolton..... 5218
 Powder blasting, H. Courtelle..... 5191
 Pump, ships, J. Brokenshiro..... 5275
 Quilling frame, A. Cornell..... 5241
 Railway carriage draw bars and springs, R. D. Chatterton..... 5250
 " car coupling, L. Dill..... 5228
 " coupling, R. D. Chatterton..... 5252
 " car ventilator, E. F. Hargreaves..... 5256
 " rail support, S. L. Porter and D. Peck..... 5247
 " track lifting machine, &c., Aldred..... 5240
 Razor, F. Erdmanski..... 5198
 Sand papering machine, J. Howe..... 5184
 Saw mill dog, A. Cunningham..... 5175
 " roller hoist, apparatus for, J. C..... 5217
 Seeding machine, J. S. Hogle..... 5160
 Seed sower, J. W. Mann..... 5197
 Sewing machine, G. Kallmeyer and E. Schmidt..... 5216
 " " R. H. St. John..... 5262
 Shaft coupling for cutters, P. Wood..... 5159
 Shovel, coal, J. Edgar..... 5161
 " and forks, lifting attachment for, F. M. Gardner..... 5229
 Skirt protector, H. M. Macdonald..... 5156
 Snow Plough, J. D. Mann..... 5233
 " " E. G. Graves..... 5200
 Spark arrester, D. Hawkesworth..... 5268
 Spinning machine, C. E. Mattison and G. W. Shaw..... 5168
 Spirits and Sugar from cereals, &c., A. Mambre..... 5242
 Steam boiler, J. H. Killey and W. Muirhead..... 5257
 " " feeding apparatus of, N. Yagu..... 5230
 " engine, compound, F. Alden..... 5276
 " " oscillating, G. B. Thurber..... 5248
 Steel, iron, &c., manufacture, apparatus and compounds for producing, S. R. Smith and J. Simpson..... 5264
 Stove, heating, A. Bettes..... 5173
 " pipe stones, machine for making, H. Wandby..... 5234
 Straw cutter, D. Maxwell..... 5194
 Street pavement, J. McBean..... 5236
 Stump extractor, B. W. Thurman..... 5168
 Sugar and spirits from cereals, &c., A. Mambre..... 5221
 Threshing machine, G. S. Thompson..... 5249
 " " grain, F. X. and A. Bellefeuille..... 5188
 Tug-plate for vehicle shafts, C. J. Riply..... 5277
 Tumbling rod and coupling joint covering, J. Harriman..... 5212
 Turbine water wheel, G. H. Jones..... 5190
 Umbrella and parasol case, R. S. Galbraith and W. Snow..... 5207
 Vapour burner, A. H. Watkins..... 5200
 Vehicles, wheel fenders for, H. F. Eberts..... 5272
 " side spring, C. L. Fisher..... 5167
 Violins, chin rest for, H. W. White..... 5269
 Waggon axle, E. Balkema and H. Beumer..... 5253
 " dumping, F. & A. Harvey..... 5193
 Washer, clothes, D. W. Rawson..... 5187
 Washing machine, J. G. Martin..... 5176
 Wells, cement pipes and drains, J. Regan..... 5179
 Whistle tree, J. A. Mackinnon..... 5184
 Wrench, pipe, L. Glynn.....

INDEX OF PATENTEES.

Alden, Farrelly, compound steam engine..... 5230
 Aldred, Robert, railway track lifting machine..... 5217
 Alvord, Stephen W., J. W. Johnson, C. M. Manville, E. E. Buffington, L. B. Rodgers, E. R. Myer, I. Vosburg, C. F. Nichols and C. M. Danlop, fanning mill..... 5182
 Ayres, Parley J., portable buggy top..... 5254
 Balkema, Edward, and H. Beumer, waggon axle..... 5269
 Barthel, Albrecht E., and W. Smith, peat machine..... 5271
 Bellefeuille, Francois X., and Achille, grain threshing mill..... 5240
 " " " horse power..... 5266
 Bettes, Alexander, heating stove..... 5261
 Beumer, Henry, and E. Balkema, waggon axle..... 5269
 Bidde, Edward, hydraulic jack..... 5174
 Blanchard, Armand H. B., cloth measures..... 5201
 Bliss, George H., cullinary apparatus..... 5153
 Boeckh, Charles, fibre and bristle combing machine..... 5153
 Hogle, James S., seeding machine..... 5217
 Bolton, Henry, potato digger..... 5178

Brookshire, John, ship's pump	5101	Mattison, Charles Z., and G. W. Shaw, spinning machine	5268
Brunch, Louis P., and S. Mohr, gravity battery	5211	Manville, Charles M., J. W. Johnson, S. W. Alvord, E. E. Bullington, L. B. Rodgers, E. R. Myer, I. Vosburg, C. F. Nichols, and C. M. Dunlop, fanning mill	5182
Bryant, George S., and S. Williams, mirling machine.....	5211	Maxwell, David, straw cutter.....	5234
Bullington, Edwin E., J. W. Johnson, C. M. Manville, S. W. Alvord, L. B. Rodgers, E. R. Myer, I. Vosburg, C. F. Nichols, and C. M. Dunlop, fanning mill.....	5182	Mayo, Israel C., culinary boiler.....	5232
Chatterton, Richard D., railway carriage coupling.....	5228	Meacom, George, cat-mental sack.....	5270
" " " draw bars and springs.....	5211	Miller, Jane A., and P. L. Downton, middlings purifier.....	5224
Clark, Charles B., brush, cloth and mop holder.....	5236	" " " manufacture of middlings flour	5225
" " " lock hinge.....	5235	Mohr, Sigismund, and L. P. Brunelle, gravity battery.....	5244
Colvix, Verplank, portable boat	5210	Moody, Henry C., children's carriages.....	5208
Commis, John, fire kindler.....	5169	Muirhead, Walter, and J. H. Killey, steam boiler.....	5242
Cook, George W., and E. H. Hoxby, car truck.....	5203	Myer, Elijah R., C. M. Manville, J. W. Johnson, S. W. Alvord, E. E. Bullington, L. B. Rodgers, I. Vosburg, C. F. Nichols, and C. M. Dunlop, fanning mill.....	5182
Copeland, George W., boots and shoes	5238	Neal, William F., horse hay rake.....	5274
" " " wax thread sewing mechanism	5246	Nichols, Colin F., E. R. Myer, C. M. Manville, J. W. Johnson, S. W. Alvord, E. E. Bullington, L. B. Rodgers, I. Vosburg, and C. M. Dunlop, fanning mill	5182
Cornell, Augustus, quilting frame.....	5275	Nickerson, John, milk and meat safe shelf.....	5222
Courteille, Herenstein, blasting powder	5218	Parmlce, Wolcott J., art of producing wrought metal carriage axle boxes.....	5196
Cunningham, Albert, saw mill deg	5181	Peck, Duane, and S. L. Porter, railway rail support.....	5256
De Warr, Laurens E., forming seams of boots and shoes....	5220	Porter, Samuel L., and D. Peck, " " "	5258
Dili, Lorenzo, car coupling.....	5250	Rawson, David W., clothes washer	5193
Downton, Robert L., and J. A. Miller, middlings purifier	5221	Reed, Joseph W., lubricator.....	5213
" " " manufacture of middlings flour.....	5225	" " " William H., gas carburetter.....	5231
Dunlop, Charles M., E. E. Bullington, J. W. Johnson, C. M. Manville, S. W. Alvord, L. B. Rodgers, E. R. Myer, I. Vosburg, and C. F. Nichols, fanning mill.....	5182	" " " air blower for carburetters.....	5243
Durand, Michel, fire escape.....	5202	Regan, John, framings and moulds to make wells, cement pipes, drains, &c.....	5176
Edgar, James, coal shovel.....	5159	Rice, John, rolling hoisting apparatus for saw mills.....	5175
Eberts, Herman F., wheel fenders for vehicles	5200	Richardson, Isaac C., steam heating apparatus.....	5171
Erdmanski, Ferdinand, razor	5210	Ridley, Charles J., tug-phi for vehicle shafts	5188
Ewart, William D., drive chain.....	5163	Robbins, Robert D., mowing and reaping machine.....	5251
Fenerty, William R., file and tool handle	5180	Rodgers, Lyman B., C. F. Nichols, E. R. Myer, C. R. Manville, J. W. Johnson, S. W. Alvord, E. E. Bullington, I. Vosburg, and C. M. Dunlop, fanning mill.....	5182
Fisher, Calvin L., side springs, vehicles.....	5272	Rogers, John S., extracting gelatine from salted fish skins	5259
Fitch, Edwin, and L. H. Hamilton, paper match box machine.....	5267	Ryckman, Samuel S. (assignee), lamp chimney cleaner.....	5205
Galbraith, Robert S., and W. Snow, umbrella and parasol case.....	5190	Rykert, Alvaro G., carriage painter's jack.....	5212
Gardner, Francis M., fitting attachment for shovels and forks.....	5161	Schmidt, Edwin, and G. Kallmeyer, sewing machine	5197
Gitchrist, Robert, extension ladder.....	5158	Seaver, Gulman W., and N. D. Martin (assignees), milk cooler.....	5206
Glynn, Lawrence, pipe wrench.....	5161	Sells, Hugh, elder mill.....	5255
Graves, Erastus G., snow plough.....	5233	Shaw, George W., and C. Z. Mattison, spinning machine	5208
Gurney, Daniel, milk cooler.....	5209	Sheldon, James H. (co-inventor and assignee), illuminating gas.....	5154
Guest, John, Jr., churn power.....	5157	Shirreff, John, freezing and refrigerating machines	5258
Gwathmey, Richard C., machine for holding objects, particularly cylindrical ones.....	5239	Simpson, Joseph, and S. R. Smith, manufacture, apparatus and compound for producing iron, steel, &c.....	5248
Hahn, Ignatius, hydraulic crane.....	5263	Skidmore, Abel F., hoop machine	5170
Hamilton, Lewis H., and E. Fitch, paper match box machine.....	5267	Smith, Samuel R., and J. Simpson, manufacture, apparatus and compounds for producing iron, steel, &c	5248
Hargreaves, Edward E., railway car ventilator.....	5252	" " " William, and A. E. Barthel, peat machine	5271
Harriman, James, tumbling rod and coupling joint cover- ing.....	5277	Spencer, Charles L., and N. W. Westcott, knitting loom.....	5245
Harvey, Thomas and Alexander, dumping waggon.....	5253	Stebins, Timothy, hydraulic elevator.....	5189
Hawkesworth, Daniel, spark arrester.....	5260	Steele, David, apparatus for extinguishing fires.....	5251
Holland, Charles L., lock nut.....	5215	St. John, Roswell H., sewing machine	5216
Holman, Chester C., box.....	5237	Thompson, George H., A. A., and M. O. Mathews, apparatus to prevent horses from jumping.....	5155
Horsey, Edward H., and G. W. Cook, car truck.....	5203	" " " Gregory, S., threshing machines.....	5221
Howe, Henry A., harvester.....	5223	Thurber, George B., oscillating steam engine	5276
" " " Jarvis, sand pastering machine.....	5198	Thurman, Benjamin W., stump extractor	5238
Imboden, John D., car axle lubricator	5199	Vosburg, Isaac, L. B. Rodgers, C. F. Nichols, E. R. Myer, C. M. Manville, J. W. Johnson, S. W. Alvord, E. E. Bullington, and C. M. Dunlop, fanning mill.....	5182
Johnson, John W., C. M. Manville, S. W. Alvord, E. E. Bullington, L. B. Rodgers, E. R. Myer, I. Vosburg, C. F. Nichols, and C. M. Dunlop, fanning mill.....	5182	Walling, George, machine for producing a current of cold air round mill stones.....	5156
Jones, George H., turbine water wheel	5212	Wandly, Henry, machine for making stove pipe gones	5173
Kalbelsch, Franklin H., carrier for acids.....	5185	Watkins, Albert H., vapour burner.....	5207
Kallmeyer, Gustav, and E. Schmidt, sewing machine.....	5197	Webster, Stephen, oil tank.....	5195
Kane, Thomas, coal ash sifter.....	5265	Westcott, Nathaniel W., and C. L. Spencer, knitting loom.....	5245
Keith, William, and H. J. Yeargin, land roller and harrow combined.....	5192	White, Eli B., barrel, or circular box	5172
Kelly, George, leather renovating machine.....	5181	" " " Hiram W., guitar head.....	5165
Killey, Joseph H., and W. Muirhead, steam boiler.....	5242	" " " chint rest for violins.....	5167
Latate, William and James, fanning mill.....	5204	Williams, Henry A., machine for rolling crimping tacks, awls, &c.....	5227
Long, Charles B., leather crimping machine	5162	" " " Samuel, and G. S. Bryant, mirling machine.....	5214
McBean, John, street pavement.....	5194	Wolf, Horace S., cleansing gas retorts.....	5219
Macdonald, Helen M., skirt protector.....	5229	Wood, Peter, shaft coupling for cutters.....	5282
Macdonald, John A., willow tree.....	5179	Worster, Alexander, locking latch.....	5273
Mambré, Alexandre, fatty matter, sugar and spirits from cereals, &c.....	5168	Yagn, Nicholas, feeding apparatus of steam boilers.....	5257
Mann, James D., snow plough.....	5156	Yeargin, Henry J., and W. Keith, land roller and harrow combined.....	5192
" " " John W., seed sower.....	5160		
Martin, James J., washing machine.....	5187		
" " " Norris D., and G. W. Seaver (assignees), milk cooler.....	5200		
Mathews, Augustus A., and Marcus O., and George H. Thompson, apparatus to prevent horses from jumping.....	5155		

THE CANADIAN PATENT OFFICE RECORD.

ILLUSTRATIONS.

Vol. III.

NOVEMBER, 1875.

No. 11.

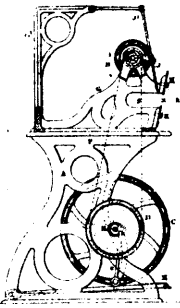

5153 Boeckh's Improvements in Fibre and Bristle Combing Machines.

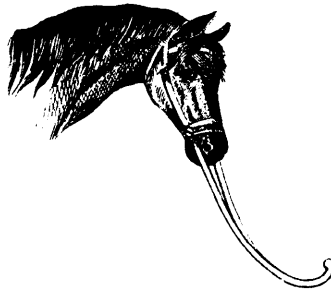

5155 Thompson & Mathews' Apparatus to Prevent Horses from Jumping.

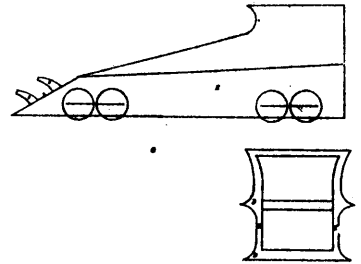

5156 Mann's Snow Plough.

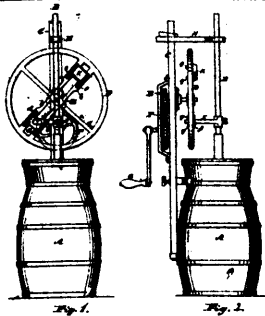

5157 Guest's Churn Power.

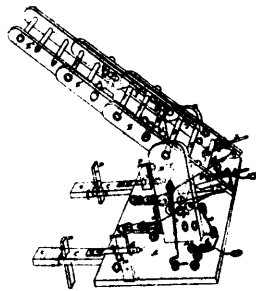

5158 Gilchrist's Extension Ladder.

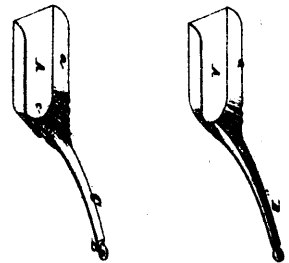

5159 Edgar's Coal Shovel.

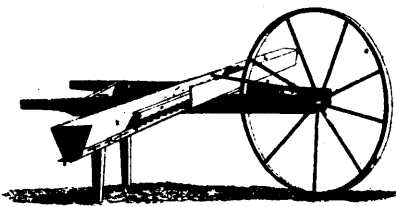

5160 Mann's Seed Sower.

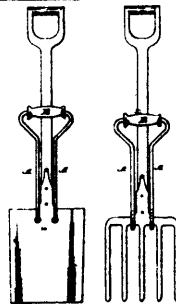

5161 Gardner's Lifting Attachment for Shovels and Forks.

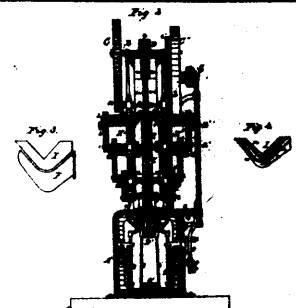

5162 Long's Leather Crimping Machine.

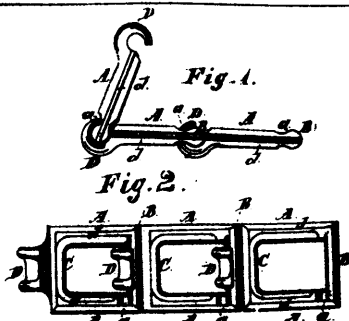

5163 Ewart's Drive-Chain.

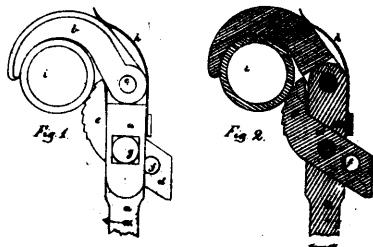

5164 Glynn's Pipe Wrench.

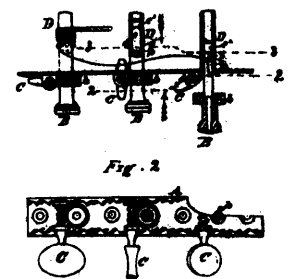

5165 White's Guitar Head.

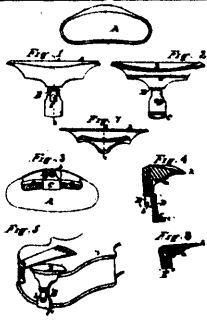

5166 White's Chin-Res for Violins.

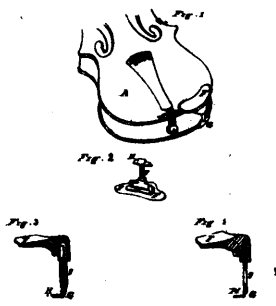

5167 White's Chin-Res for Violins.

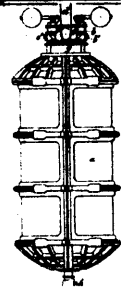

5168 Manbré's Process and Apparatus for Breaking Cereals and other Vegetable Substances for the Extraction of Faty Matter therefrom and the Manufacture of Sugar and the Production of Spirits, &c.

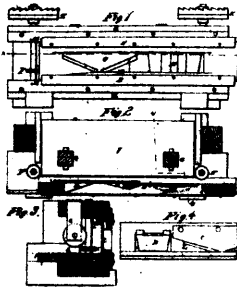

5170 Skidmore & Moore's Hoop Machine.

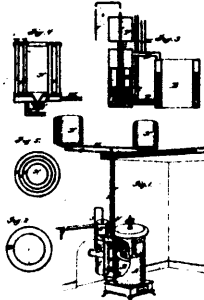

5171 Richardson's Steam Heating Apparatus.



5172 White's Barrel or Circular Box.

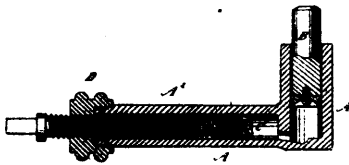

5174 Biddle's Hydraulic Jack.

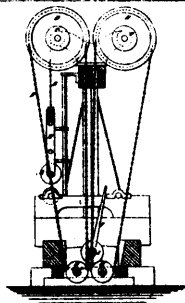

5175 Rice's Roller Hoisting Apparatus.

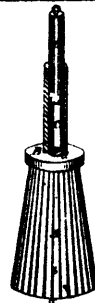

5176 Regan's Framings and Moulds to make Wells, Cement Pipes, Drains, &c.

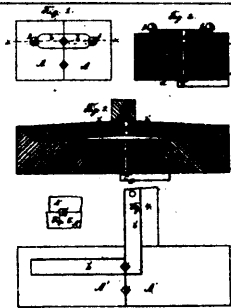

5177 Clark's Dies for Heading and Squaring Bolts.

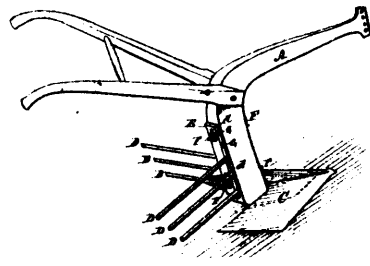

5178 Bolton's Potato-digger.

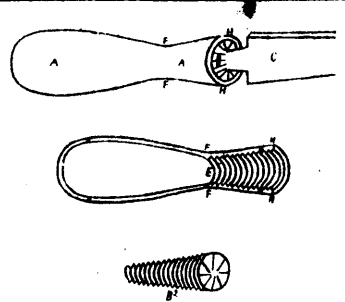

5180 Fenerty's File and Tool Handle.

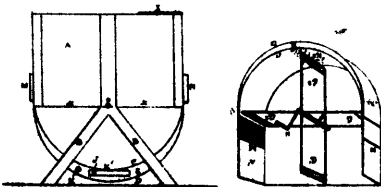

5181 Kelly's Feather Renovating Machine.

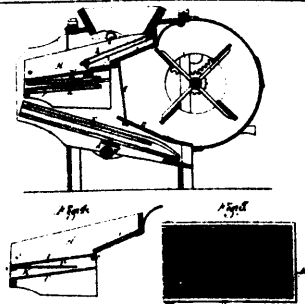

5182 Johnson, Manville, Alvord, Buffington, Rodgers, Myer, Wosburg, Nichols & Dunlap's Fanning Mill.

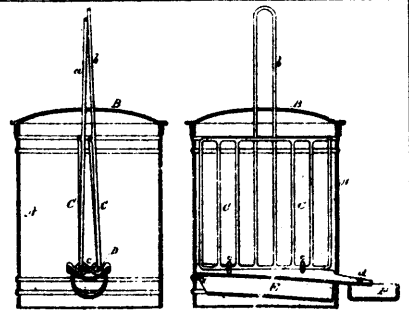

5183 Bliss' Culinary Apparatus.

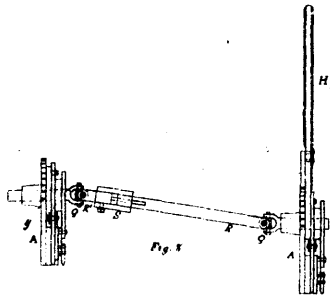

5184 Cunningham's Saw-mill Dog.

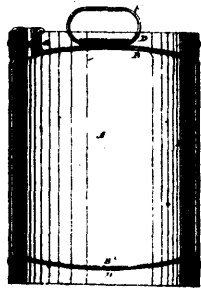

5185 Kalbfleisch's Carrier for Acid.

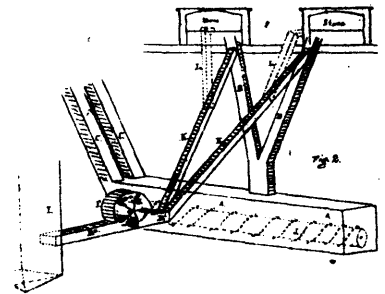

5186 Walling's Machine for Producing a Current of Cold Air around Mill Stones.

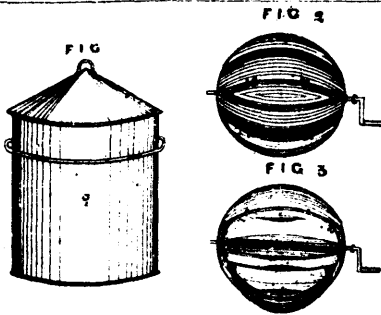

5187 Martin's Improvements in Washing Machines.

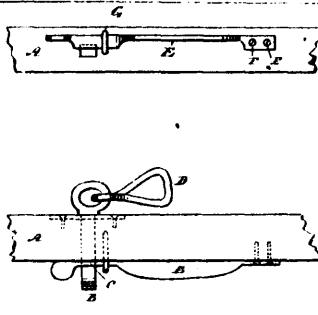

5188 Riply's Tug-pin for Vehicle Shafts.

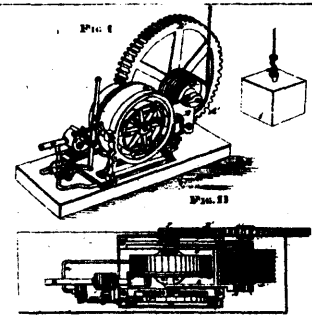

5189 Stebins' Hydraulic Elevator.



5190 Galbraith's Umbrella and Parasol Case.

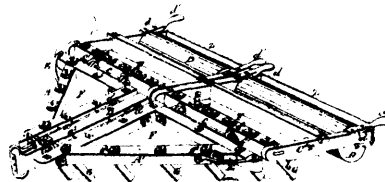

5192 Yeargin & Keith's Combined Land Roller and Harrow.



5193 Rawson's Clothes Washers.

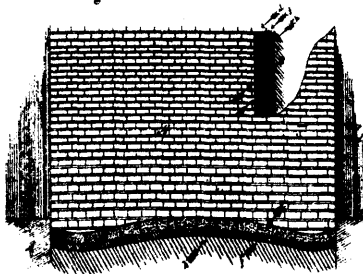

6194 McBean's Improvements on Street Pavements.

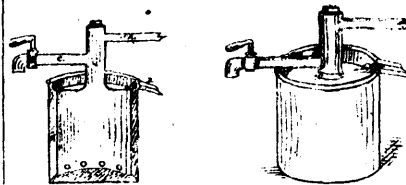

5195 Webster's Oil Tank.

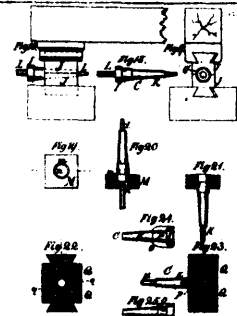

5196 Parmlee's Art of Producing Wrought Metal Carriage Axle Boxes.

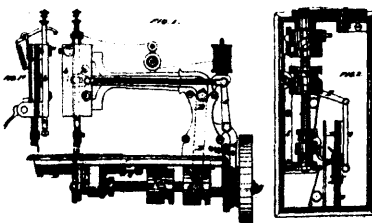

5197 Kollmeier & Schmidt's Improvements on Sewing Machines.

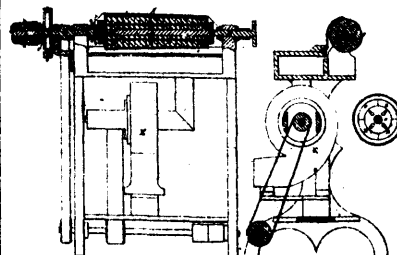

5198 Howe's Sand Papering Machine.

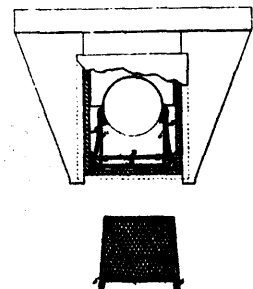

5199 Imboden's Car Axle Lubricator.

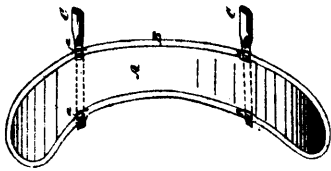

5200 Eberts' Improvements on Wheel-fenders for Vehicles.

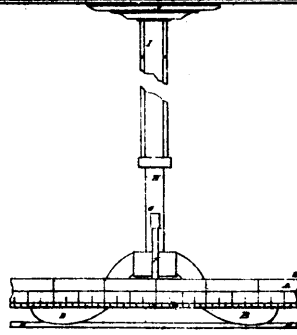

5201 Blanchard's Improvements on Cloth Measures.

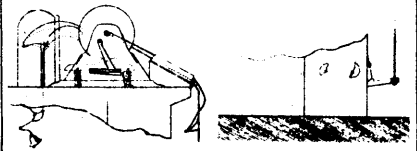

5202 Durand's Fire Escape.

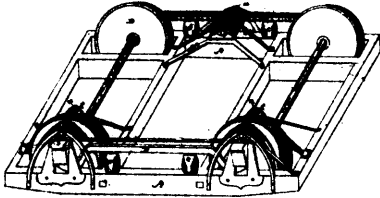

5203 Cook & Horsey's Improvements on Car-trucks.

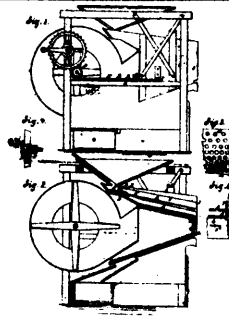

5204 Lambie's Improvements on Fanning Mills.



5205 Mutter's Lamp Chimney Cleaner.

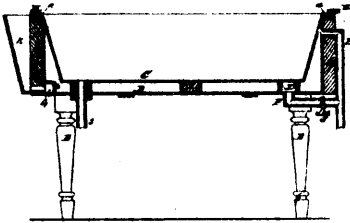

5206 Hodgdon's Milk Cooler.

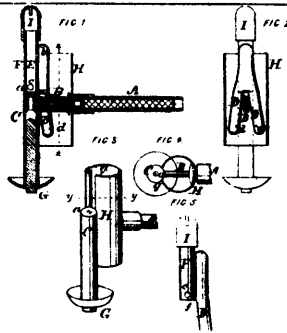

5207 Watkins' Vapour Burner.

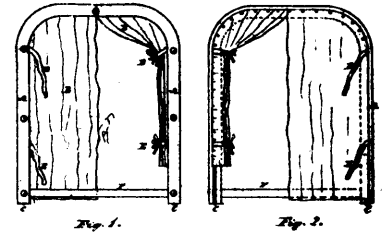

5208 Moody's Improvements on Children's Carriages.

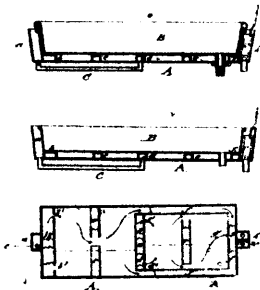

5209 Gurnsey's Improvements on Milk Coolers.

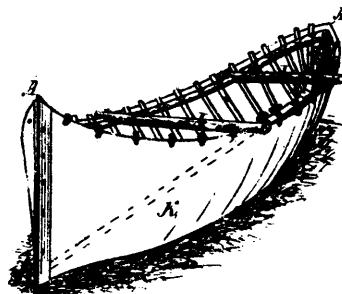

5210 Colvin's Portable Boats.

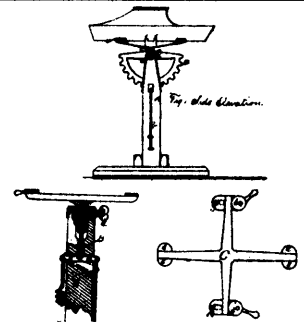

5211 Rykert's Carriage Painter's Jack.

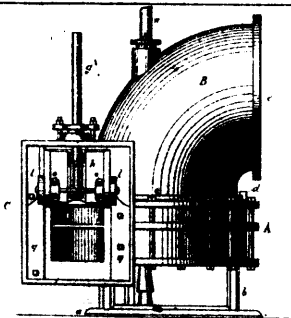

5212 Jones' Improvements in Turbine Water Wheels.

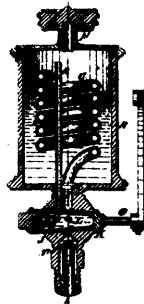

5213 Van B. Osborn's Improvements on Lubricators.

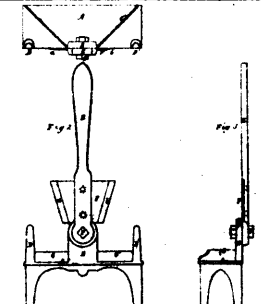

5214 Williams & Bryant's Mitring Machine.

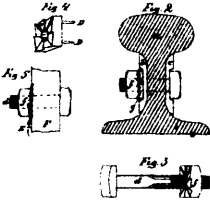

5215 Holland's Lock-nut.

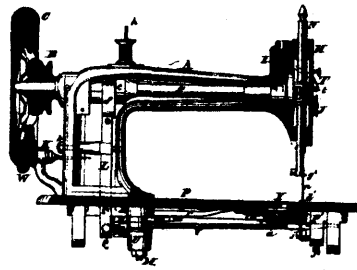

5216 St. John's Sewing Machine.

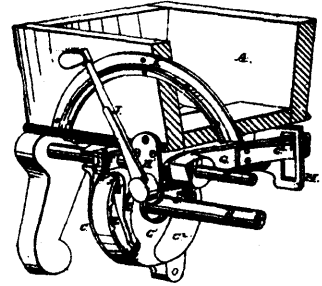

5217 Bogle's Seeding Machine.

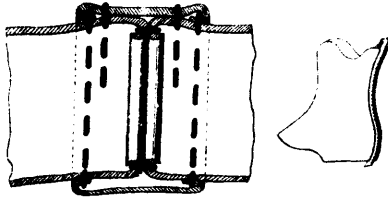

5220 De Waru's Improvements on Forming Seams of Boots and Shoes, &c.

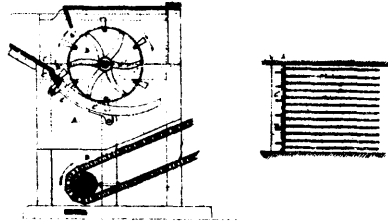

5221 Thompson's Improvements on Threshing Machines.

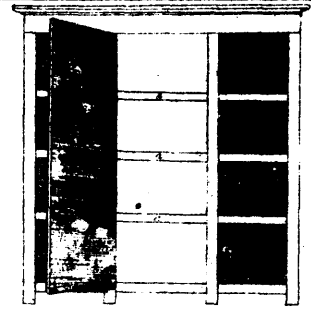

5222 Nickerson's Milk and Meat Safe Shelf.

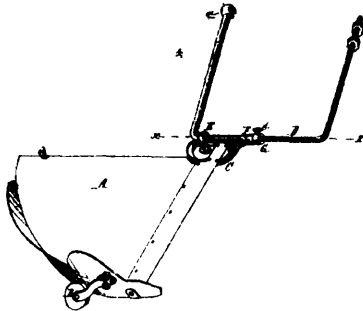

5223 Howe's Improvements on Harvesters.

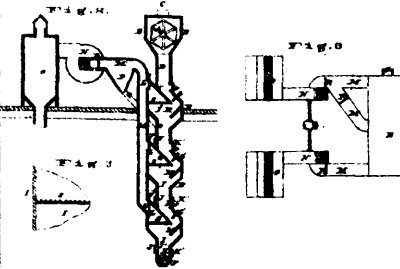

5224 Downton & Miller's Middlings Purifier.

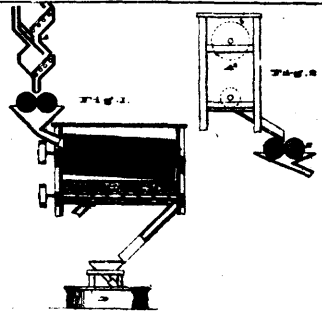

5225 Downton & Miller's Process of Manufacturing Middlings Flour.

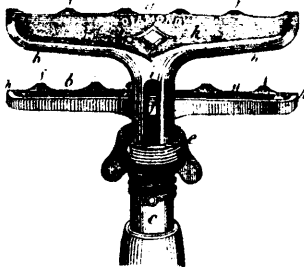

5226 Clark's Brush, Cloth and Mop Holder.

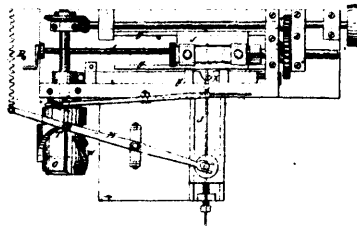

5227 Williams' Machine for Rolling Crimping Tacks, Awls, &c.

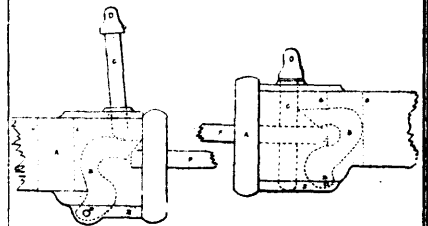

5228 Chatterton's Railway Carriage Coupling.

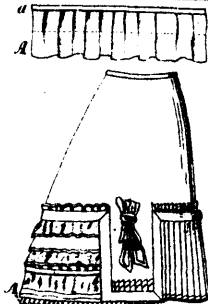

5229 Macdonald's Skirt Protector.

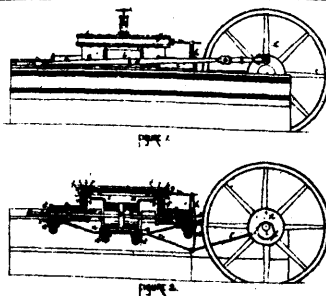

5230 Alexander's Compound Steam Engine.

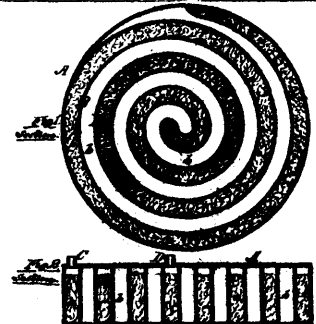

5231 Reed's Gas Carburettor.

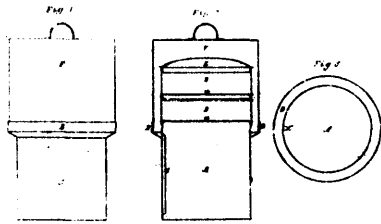

5232 Mao's Culinary Boiler.

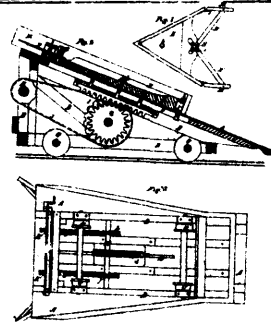

5233 Graves' Improvements in Snow-Ploughs.

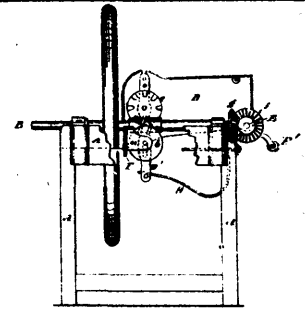

5234 Maxwell's Improvements on Straw Cutters.

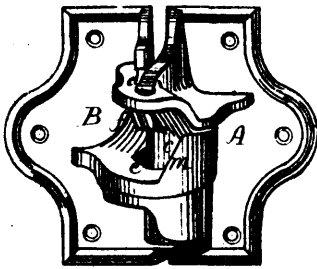

5235 Clark's Lock Hinge.

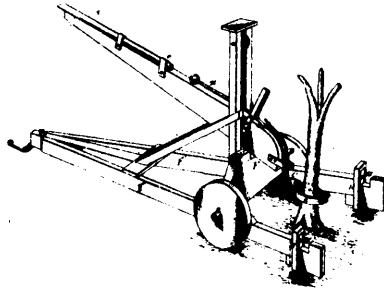

5236 Thurman's Stump Extractor.

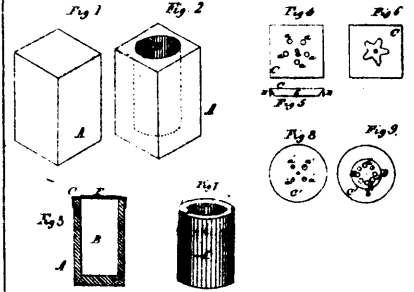

5237 Holman's Improvements in Boxes.

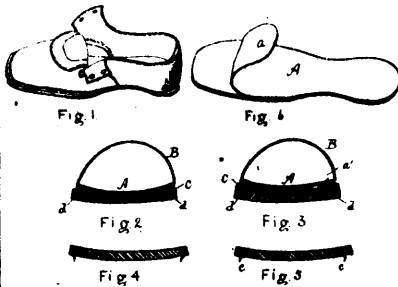

5238 Copeland's Improvements in the Manufacture of Boots and Shoes.

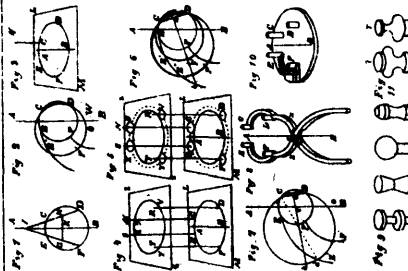

5239 Gwathmey's Machine for Holding Objects, particularly Cylindrical Ones.

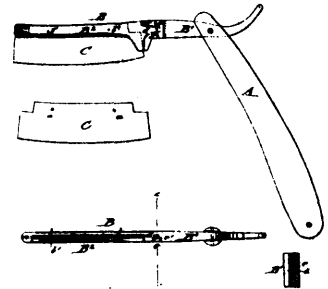

5240 Erdmansk's Improvements on Razors.

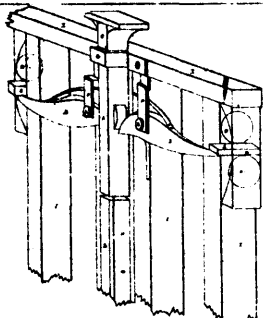

5241 Chatterton's Improvements in the Construction of Railway Carriage Draw-bars and Springs

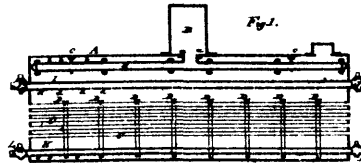

5242 Killey & Muirhead's Improvements in Steam Boilers.

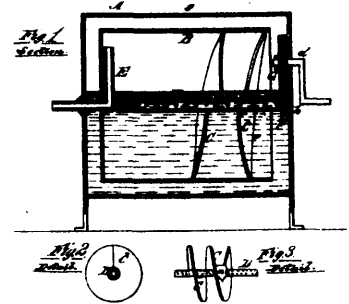

5243 Reed's Air Blower for Carburetters.

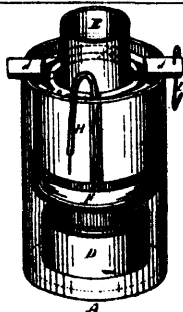

5244 Brunelle & Mohr's Gravity-Battery.

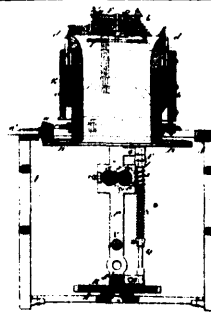

5245 Wescott & Spencer's Knitting Loom.

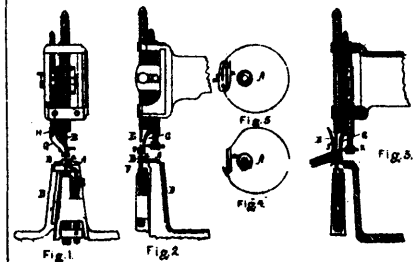

5246 Ballo's Boot and Shoe Wax Thread Sewing Mechanism.

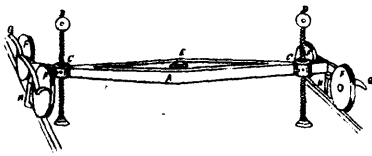

5247 Aldred's Rail-Road Track Lifting Machine.

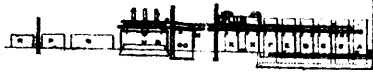

5248 Smith & Simpson's Improvements on Production and Manufacture of Iron, Steel, and other Metals, and on the Apparatus and Compounds employed therein.

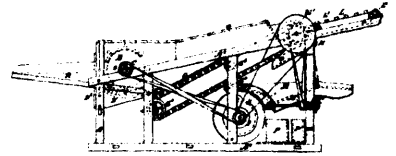

5249 Bellefeuille's Grain Threshing Machine.

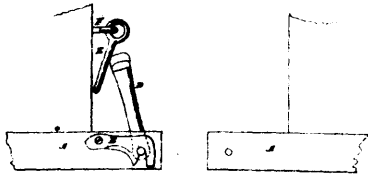

5250 Dill's Car-Coupling.

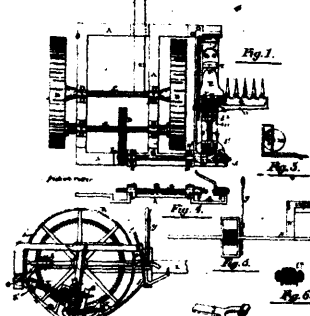

5251 Robbins' Improvements in Mowing and Reaping Machines.

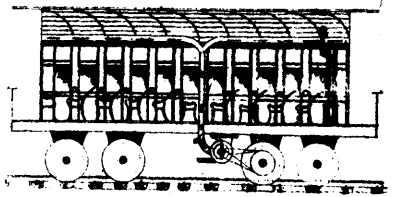

5252 Hargreaves' Railway Car Ventilator.

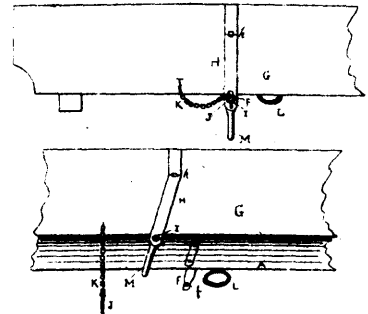

5253 Harvey's Dumping Waggon.

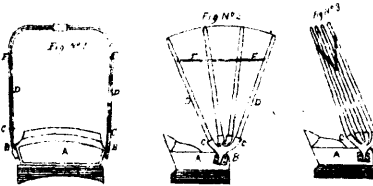

5254 Ayres' Portable Buggy Top.

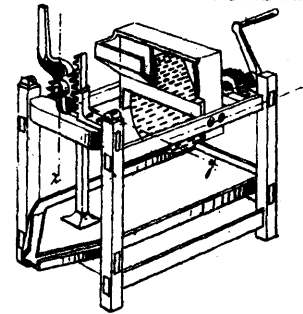

5255 Sells' Cider Mill.

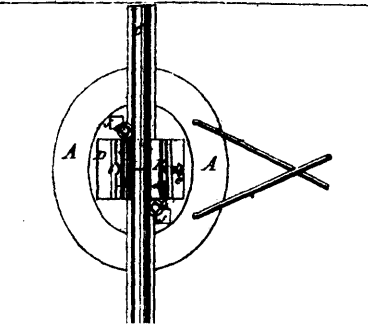

5256 Porter & Peck's Railway Rail Support.

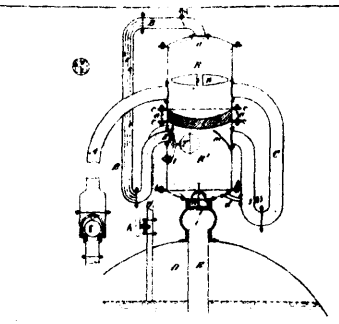

5257 Yaga's Improvements on Feeding Apparatus of Steam Boilers.

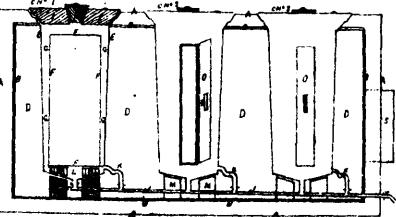

5258 Shirreff's Improvements on Freezing and Refrigerating Machines.

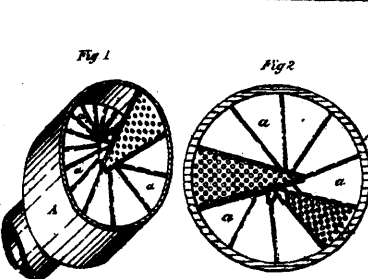

5260 Hawkesworth's Spark Arrestor.

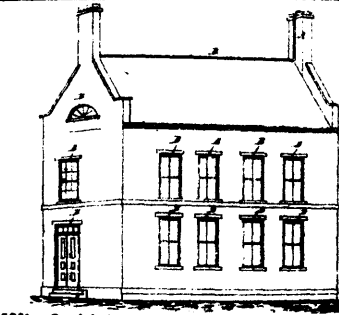

5261 Steele's Improvement on Apparatus for Extinguishing Fires.

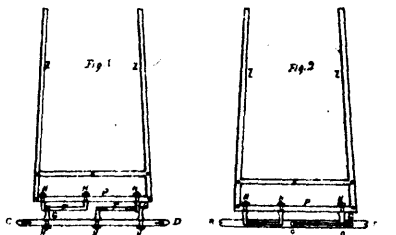

5262 Wood's shaft-coupling for Cutters.

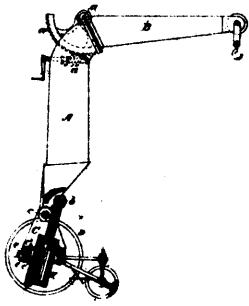

5283 Haha's Hydraulic Crane.

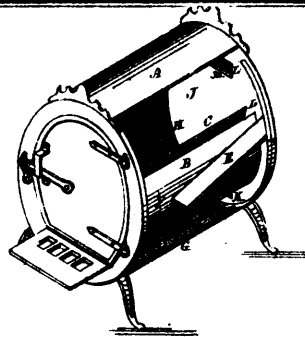

5284 Bettes' Heating Stoves.

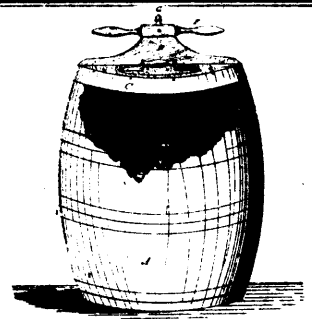

5285 Kane's Coal Ash Sifter.

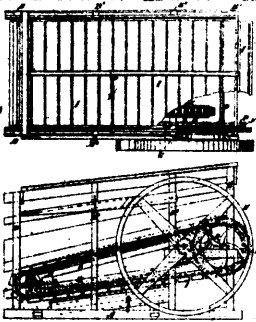

5286 Bellefleur's Horse-power.

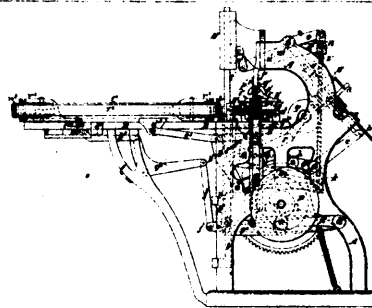

5287 Clarke's Paper Match Box Machine.

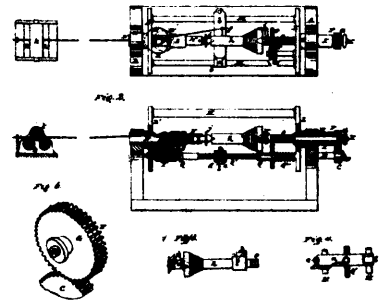

5288 Mattison & Shaw's Spinning Machine.

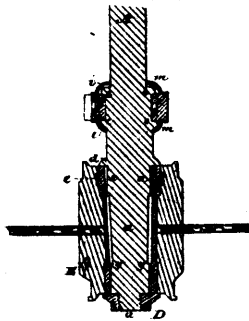

5289 Balkema & Beumer's Waggon Axle.

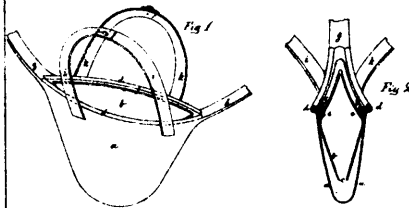

5270 Meacon's Catamential Sack.

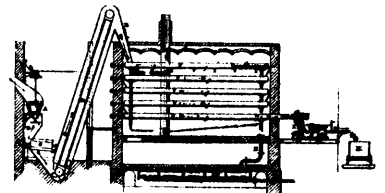

5271 Barthel & Smith's Peat Machine.

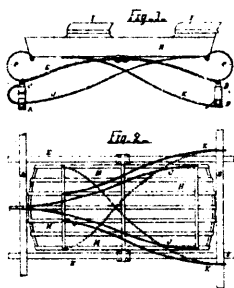

5272 Fisher's Improvements in Side-spring Vehicles.

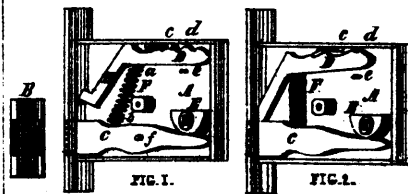

5273 Worster's Locking Latch.

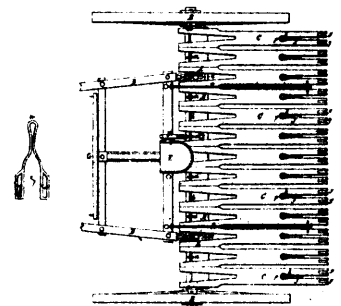

5274 Neal's Horse Hay Rake.

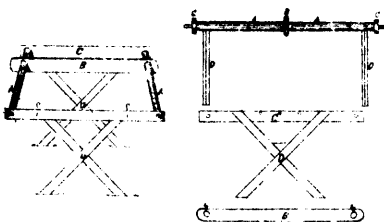

5275 Cornell's Quilting-frame.

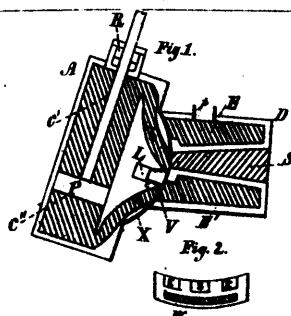

5276 Thurber's Oscillating Steam Engine.

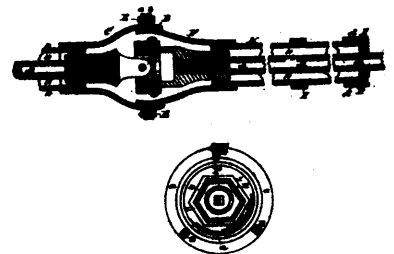

5277 Harriman's Tumbling Rod and Coupling Joint Covering.