

Technical and Bibliographic Notes / Notes techniques et bibliographiques

The Institute has attempted to obtain the best original copy available for filming. Features of this copy which may be bibliographically unique, which may alter any of the images in the reproduction, or which may significantly change the usual method of filming, are checked below.

L'Institut a microfilmé le meilleur exemplaire qu'il lui a été possible de se procurer. Les détails de cet exemplaire qui sont peut-être uniques du point de vue bibliographique, qui peuvent modifier une image reproduite, ou qui peuvent exiger une modification dans la méthode normale de filmage sont indiqués ci-dessous.

Coloured covers/
Couverture de couleur

Coloured pages/
Pages de couleur

Covers damaged/
Couverture endommagée

Pages damaged/
Pages endommagées

Covers restored and/or laminated/
Couverture restaurée et/ou pelliculée

Pages restored and/or laminated/
Pages restaurées et/ou pelliculées

Cover title missing/
Le titre de couverture manque

Pages discoloured, stained or foxed/
Pages décolorées, tachetées ou piquées

Coloured maps/
Cartes géographiques en couleur

Pages detached/
Pages détachées

Coloured ink (i.e. other than blue or black)/
Encre de couleur (i.e. autre que bleue ou noire)

Showthrough/
Transparence

Coloured plates and/or illustrations/
Planches et/ou illustrations en couleur

Quality of print varies/
Qualité inégale de l'impression

Bound with other material/
Relié avec d'autres documents

Continuous pagination/
Pagination continue

Tight binding may cause shadows or distortion along interior margin/
La reliure serrée peut causer de l'ombre ou de la distorsion le long de la marge intérieure

Includes index(es)/
Comprend un (des) index

Title on header taken from:/
Le titre de l'en-tête provient:

Blank leaves added during restoration may appear within the text. Whenever possible, these have been omitted from filming/
Il se peut que certaines pages blanches ajoutées lors d'une restauration apparaissent dans le texte, mais, lorsque cela était possible, ces pages n'ont pas été filmées.

Title page of issue/
Page de titre de la livraison

Caption of issue/
Titre de départ de la livraison

Masthead/
Générique (périodiques) de la livraison

Additional comments:/
Commentaires supplémentaires:

Pagination is as follows: [i]-ii, [337]-352, iii-iv p.

This item is filmed at the reduction ratio checked below/
Ce document est filmé au taux de réduction indiqué ci-dessous.

10X	12X	14X	16X	18X	20X	22X	24X	26X	28X	30X	32X
<input type="checkbox"/>	<input type="checkbox"/>	<input type="checkbox"/>	<input type="checkbox"/>	<input type="checkbox"/>	<input type="checkbox"/>	<input type="checkbox"/>	<input type="checkbox"/>	<input type="checkbox"/>	<input type="checkbox"/>	<input checked="" type="checkbox"/>	<input type="checkbox"/>

Educational Weekly

VOL. I.

THURSDAY, MAY 28, 1885.

Number 22.

SCHOOLS.

Young Ladies' Seminary.

I propose opening in this city by the first of September a School for Young Ladies. Pupils received from August 23rd to September 1st, when all branches will be taught by efficient Teachers. Music, Drawing and Fine Arts, by special Professors. For terms per Board and Tuition,

Address,
MRS. A. R. RAE,
Principal,
 TORONTO P.O.

BENGOUGH'S SHORTHAND AND BUSINESS INSTITUTE. Public Library, Building, Toronto. Shorthand, Type-writing, Business Forms, and Correspondence. Experienced and Practical Teachers. Thorough Tuition. Rates reasonable. THOS. BENGOUGH, (Official Reporter, York Co. Courts), Principal. GEO. BENGOUGH, Sec. MARY BENGOUGH, Type-Writing Supt.

TAILORING.

AGENTS WANTED - FOR OUR NEW WORK just out. \$10.00 per day easily made. Apply at once.
D. W. MOODY & CO.,
 102 King Street West, Toronto.

A. MACDONALD, MERCHANT TAILOR,
 355 Yonge Street, Toronto, (opposite L. B.). Any gentleman in want of a first-class Suit of Clothes can have them by leaving their orders with the above, who makes a specialty of **FIRST-CLASS CLOTHING.**

MORGAN M. RENNER, ARCHITECT.
 MAIL BUILDING. TORONTO.

Royal Canadian Academy of Arts
 -AND-
 ONTARIO SOCIETY OF ARTISTS
 -COMBINED-
EXHIBITION
Paintings and Drawings

WILL BE OPEN TO THE PUBLIC DAILY
FROM FRIDAY, MAY 15TH.

Admission, 25 Cents.

14 KING STREET WEST, TORONTO.

TEACHERS FOR VACATION!

To handle our popular subscription books and "Peerless" Family Bibles. Very saleable. First-class in every respect, specially suited to the times and the wants of the Canadian public. \$100, \$125, \$150, \$175 and up to \$192 are the figures netted by teachers selling our books previous vacations. Write for new catalogue and 1885 teachers offer, special and exclusive to members of the profession. J. S. Robertson & Bros., Union Block, Toronto; Chronicle Buildings, Whitby, 110 Dundas Street, London, Ont.

"THE CURRENT" CHICAGO, U. S. A. The great Literary and Family Journal of our time. Clean, perfect, grand! Over 600 brilliant contributors. \$3.50 yearly, 6 mo., \$3.00, bound vol. (6 mo.) \$3.00. Buy it at your newsdealer's - Sample copy, 10 cents. The following splendid offer is made to Teachers exclusively: **TEACHERS!** Yearly price, if ordered before April 1, 1885, \$2.50; between April 1 and July 1, \$2.75; between July 1 and Dec. 31, \$3.00. Subscribe at once!

DRAWING.

NOW READY!

DRAWING MODELS

Required with the Authorized Series CANADIAN DRAWING COURSE, consisting of
 6 14 inch Vases,
 1 14-inch Cylinder,
 2 14-inch Hoops,
 1 14-inch Hoop, iron,
 1 2-ft. Skeleton Cube.
 The Cube hinged for folding up.
 Painted and put in a strong box, with slide lid,
PRICE, \$8.75.

We are in a position to supply cheaply and of the best material all the FURNITURE and APPLIANCES for Kindergarten Schools. Correspondence invited and estimates given.

SELBY & CO.,

28 Wellington St. East, Toronto.

Send for Tracts on the Kindergarten.
 Mailed Free to any Address.

- THE -

REVISED BIBLE

IS TO HAND THIS DAY.

Various Types and Bindings from
 \$1.00 upwards.

JOHN YOUNG,
 Upper Canada Tract Society, 102 Yonge St.

THIS ADVERTISEMENT WILL NOT APPEAR AGAIN.

The NEW ARITHMETIC

IS NOW READY.

PRICE, \$1.00.

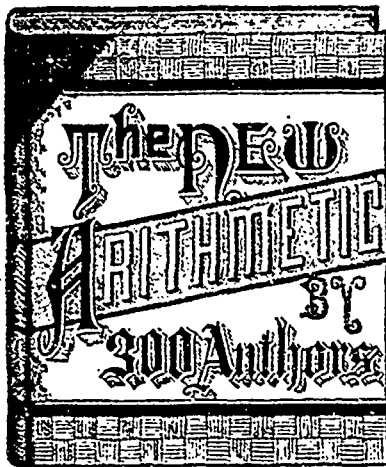

Hundreds of copies are being mailed daily. More than half of the teachers of Canada have already ordered the book. It contains twice as many examples as any other book now in use in Canada. The problems and exercises are new. There is not a single poor problem in the book. The work is better printed and more beautifully bound than any other school book issued in the Dominion.

Every teacher who has not a copy will be considered behind the times. It is The Book for admission to High Schools, Intermediate and Teacher's Examinations.

The leading educationists of Toronto place The New Arithmetic in advance of all other arithmetics published

THE HINTS AND ANSWERS. Price 50 cents.

This is a neat little book containing the answer to every exercise contained in The New Arithmetic. It contains also hints to the solutions of the more difficult examples, and some excellent hints upon *new methods*. It is a very valuable companion to The New Arithmetic. Every teacher should have both.

GRAND SPECIAL OFFER.

To every reader of the EDUCATIONAL WEEKLY who, before June 20, 1885, sends us ONE DOLLAR, we shall mail post free a copy of The New Arithmetic, a copy of The Hints and Answers, a copy of the June number of The School Supplement. This offer will never be made again. Don't let it slip.

The June number of The School Supplement will be the finest number of that paper ever issued. It will contain a beautiful portrait of Mark Twain, with biographical sketch by T. C. L. Armstrong, M.A., LL.B.; a moonlight Mississippi scene; portraits and biographies of Bismarck and Florence Nightingale, illustrated lesson in railroad geography; ten columns of practical school-room matter; brief biographies; articles on old-time schools; and much miscellaneous reading.

The books are ready and will be forwarded to any address by return mail.

Address, **EATON, GIBSON & CO, TORONTO, ONT.**

The Educational Weekly,

PUBLISHED BY

THE GRIP PRINTING AND PUBLISHING CO.,

SAMUEL J. MOORE, *General Manager.*

C FRASER, *Business Manager Educational Weekly Dept.*

JOHN E. BRYANT, M.A., *Editor.*

T. ARNOLD HAULTAIN, M.A., *Assistant Editor.*

CONTENTS OF THIS NUMBER

SHORTER EDITORIALS	337
CONTEMPORARY THOUGHT	338
NOTES AND COMMENTS	339
LITERATURE AND SCIENCE:	
The Fleet.....	T. HAYASHI, 340
The Lamp of Memory.....	Kuskin, 340
CURRENT EDUCATIONAL OPINION:	
Address by Dr. Nelles.....	342
LONGER EDITORIAL:	
Composition in Schools.....	344
Book Review.....	344
Books Received.....	344
Table Talk.....	344
SPECIAL PAPERS:	
The Adjective in Literature	A. H. Morrison, 346
Rivers	C. C. James, B.A., 346
Clearness	347
PRACTICAL ART:	
Perceptive, XII.	A. J. Reading, 348
PUBLIC SCHOOL:	
Language Lessons.....	349
Learning to Read.....	349
HIGH SCHOOL:	
Questions on "The Lady of the Lake,"	Thos. O'Hagan, B.A., 350
EDUCATIONAL INTELLIGENCE:	
The Contents of Children's Minds.. From the <i>Pall Mall Gazette</i>	350
CORRESPONDENCE:	
Arbor Day in Ontario.....	351
EXAMINATION PAPERS:	
Entrance to High Schools—Crammar	352

TERMS OF SUBSCRIPTION.

Two Dollars per annum, in advance.
 Clubs of five at \$1.60 each, or the five for \$8.00.
 Clubs of twenty at \$1.50 each, or the twenty for \$30.00.

Business communications and communications intended for the Editor should be on separate papers.

ADDRESS—**EDUCATIONAL WEEKLY,**
GRIP OFFICE, TORONTO.

TERMS OF ADVERTISING.

[NO DEVIATION.]
 Number of insertions..... 1 2 3 5 10 20 30
 Per Line, each insertion, 10c. 9c. 8c. 7c. 6c. 5c. 4c.
 One Column (47 lines), .. \$13 00 \$11 50 \$10 00 \$9 00 \$8 00
 Half Page .. 19 00 17 00 15 00 13 00 11 00
 Two Columns, .. 24 00 22 00 19 00 17 00 15 00
 One Page, .. 33 00 30 00 27 00 24 00 20 00
 Twenty per cent. advance on the above rates for preferred position, when specified.
 Advertisements must be acceptable in every respect.
 Copy received until Tuesday noon.

MONTREAL AGENCY:
124 St. James Street. F. N. BOXER, Manager.

JUST OUT.

THE WAR IN THE SOUDAN

And the causes which led to it.

Profusely illustrated, Portraits and Biographical sketches of the leading Generals on both sides. Fine map of the seat of war in 3 colors.

A Thrilling Narrative.

This work is not a mere compilation of newspaper and magazine articles, but is written in a popular style, specially for the Grip Printing & Publishing Company, by a gentleman who spent some years in the East, and is thoroughly conversant with the subject.

PRICES,

Paper Covers, \$0 75.
 English Cloth, Gilt Side Stamp, 1 25.

Grip P'g & Pub. Co., Toronto.

AGENTS WANTED.

Special Notice to Teachers.

During vacation Teachers can largely increase their salary by selling my famous Teas to consumers. No peddling; no humbug. I will positively guarantee that any pushing live man can make \$150 per month. It costs next to nothing to give it a trial. Others are making money fast, why not you? Will you be one. Send for Terms.

JAMES LAUT, IMPORTER, TORONTO.

A great chance for Agents, Farmers' Sons, School Teachers, and others to make money. Ten dollars a day paid. We stand ahead, and take the lead on all other tea houses in Canada, and offer agents the best chance ever known to make money. Our system is entirely new. For full particulars address the Canada Pacific Trading and Importing Company, (wholesale tea and coffee Importers) 120 Bay Street, Toronto. (Enclose 3c. stamp for reply.)

AGENTS WANTED everywhere, to handle something entirely new. Easily carried; easily sold; profits large. Teachers during their spare moments make enough money to pay all their expenses. Circulars free. J. Z. HUSBAND & CO., 31 King St. West, Toronto.

AGENTS WANTED Everywhere, to handle something entirely new. Easily carried; easily sold; profits large. Teachers during their spare moments make enough to pay all their expenses. Address THE POWELL SAFE LOCK CO., 3 Jordan Street, Toronto.

TEACHERS Wanting remunerative employment during the holidays can have it by addressing C. R. PARISH & CO., 10 King Street East, Toronto.

MISCELLANEOUS.

C. H. MACDONALD,
Real Estate Agent, Conveyancing, Engrossing, etc
COLLECTIONS MADE.

53 ARCADE, YONGE STREET,
TORONTO.

HOWIE'S DETECTIVE AGENCY,

Twenty years experience. 35 Melinda St., Toronto, Ont.
 REFERENCES:
 Hon Wm. McLaughlin, Ottawa, Ont.; G. I. Shepley, M. Doucill & Cox, Henderson & Small, Bigelow & Morison, Murray & Mandock, H. L. Fraser, B. B. Adler, Barristers, Toronto; Thos. Robertson, Q.C., M.P.P., John M. Gilson, M.P., Barristers, John Crear, County Crown Attorney, Edward Martin, Q.C., Carstairs & Cahill, Richard Martin, Frank McKelkin, Barristers, Hamilton; Chiefs of Police of Hamilton, London, Belleville, Galt and Dundas.
 M. HOWIE, Manager.

HELP OF ALL KINDS, both male and female, supplied on short notice. Address—
 HURD, RYAN & CO., 53 King St. East, Toronto.

A. W. SPAULDING, L.D.S.,
Dentist, 51 King Street East, Toronto.
 Residence—47 Lansdowne Avenue, Parkdale.

A GOOD INVESTMENT.—It pays to carry a good watch. I never had satisfaction till I bought one of WZLERI & TROWERS' reliable watches, 171 Yonge Street, east side, and door south of Queen.

MISCELLANEOUS.

THE IMPROVED MODEL

Washer and Bleacher.

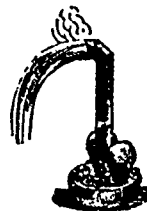

Weights only six pounds and can be carried in a small valise. Satisfaction guaranteed or money refunded.

\$1,000 REWARD
FOR ITS SUPERIOR.

Pat. N. Au 2, 1884.
 C. W. Dennis, Toronto clothes have that pure whiteness which no other mode of washing can produce. No rubbing required, no friction to injure the fabric. A ten-year-old child can do the washing as well as older person.
 To place it in every household the price has been placed at \$3.00, and if not found satisfactory within one month from date of purchase, money refunded.
 Send for circulars. AGENTS WANTED. Delivered to any Express office in Ontario or Quebec, charges paid for \$3.50.

C. W. DENNIS,

Toronto Bargain House,
213 Yonge St., Toronto, Ont.

Please mention this paper.

PILES CURED Without Operation.

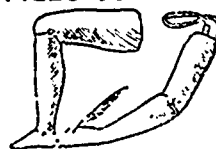

ARTIFICIAL LIMBS

and appliances for Club Feet, Hip and Knee Joint Diseases, Spinal Curvature and all Deformities. See my Truss for Rupture—never fails. Diseases of Kidneys, Liver, Blood, Skin, and Nervous System. Dyspepsia, Constipation, Epilepsy, Tapeworm, Consultation Free.

DR. REEVE, M.C.P.S.O.,
148 King St., Corner Jarvis, Toronto.



RUPTURE. EGAN'S IMPERIAL TRUSS

with a spiral spring. The last and best ever invented. Took 20 years to make it perfect. Never moves from position even the sixteenth of an inch. Cures every child, and 8 out of every 10 adults. Holds the worst hernia during the hardest work, or money refunded. Circulars free. Contains your neighbor's testimonies, price list, etc. Call or address "Egan Imperial Truss Co., 23 Adelaide Street East, Toronto, Ont."

SEALS, Rubber Stamps



School Section, Township, County, Lodge & other Seals. Stamps of all Kinds.
 Kenyon, Tingley & Stewart Mfg Co.
 72 KING ST. WEST.

CASSELL'S LINEAR DRAWING,

Containing the work required for Elementary Art School and Mechanics' Institute Examinations in Geometry. Sent to any address, post free, on receipt of 70 cents.

Address, BOX A,
EDUCATIONAL WEEKLY Office.

TO OUR PRESENT SUBSCRIBERS.

To every subscriber who secures an additional subscriber at the regular single subscription rate of Two Dollars, the publishers will send POSTPAID one copy each of

Ayres' Orthoëpist, and Ayres' Verbalist,

Canadian Standard Editions, adapted by T. C. L. Armstrong, M.A., LL.B., published by the Canada Publishing Co., and Authorized by the Minister of Education

The books contain 230 and 250 pp. respectively, and are handsomely bound in red cloth. These books are recommended by the Minister of Education for preparation for all the Departmental Examinations. Their price is 50 cents each. Remember that for one subscription you obtain BOTH these books. Try to get your fellow teachers and your trustees to take the EDUCATIONAL WEEKLY. Many trustees are already subscribers, and many more will become so when the merits of the WEEKLY are brought before them.

The same books will be given to every subscriber who sends in a club of FIVE new subscribers at \$1.60 each.

Send in your subscriptions early, as this offer will be open only for a short time.

ADDRESS, EDUCATIONAL WEEKLY;

SPECIAL OFFER!

THE EDUCATIONAL WEEKLY

From now until January 1st, 1886, only \$1.25; or \$1.00 each to Clubs of Five.

SUBSCRIBE AT ONCE!

The Educational Weekly.

TORONTO, MAY 23, 1885.

WE have a word of encouragement and advice to say to young teachers. Do they fully recognize their responsibilities? In the prime of life, their mental faculties sharpened by recent education and present intellectual activity; keenly alive to all that is going on around them; brought into constant contact with other minds as active as their own; with opinions formed on a variety of topics; and with all their faculties concentrated on the explanation of topics at present unsolved, but which are on the high road to solution—is it any wonder that to young men, and to young teachers above all, there is attached a great and unavoidable responsibility? The older men amongst us have also their own particular responsibilities, but they do not *share* those of the younger generation. Let us not lose sight of this. They are different, as in degree, so in kind. It is the business of the younger members of the community to see that they are not content to follow in the old grooves. Where were progress if none undertook to discover new paths? And to whom should devolve better the duty of discovering these new paths than to those with full, untrammelled, unprejudiced, unfettered, unbiased, intellectual powers?

We are not depreciating the value of matured judgment, of old and experienced methods of thought. Far, very far, from it. Those who have passed the spring-time of life have a value in the state which can be transferred to no other persons. They are the ballast, the equilibrating power in the sphere of thought. They may be compared to the House of Lords in the British constitution. And, to follow out the simile, it is in the lower House that we look for progressive measures, for those acts that will add to our intellectual wealth.

And we may most legitimately and rationally do this. "Owen Meredith" has described the younger elements of progress as a dwarf upon a giant's shoulders.

"There were giants in those irreclaimable days; but in these days of ours, In dividing the work, we distribute the powers. Yet a dwarf on a dead giant's shoulders sees more Than the live giant's eye-sight availed to explore, And in life's lengthened alphabet what used to be To our sires X Y Z, is to us A B C."

The dwarf sees all that the giant sees, but he also sees much more. The giant will give him the direction in which to work, and will explain to him what he sees, as far, that is, as the giant himself sees; it is the duty of

the dwarf to look beyond, and to use that explanation in this farther-reaching view.

Again, although the greatest achievements of men have been produced at very various periods of life, yet, speaking generally, we think it will be conceded that the time of the greatest activity of the brain is in youth—from twenty-five to thirty we believe some have placed it.

But this activity for which we have argued must be used with caution. Let it be brought into play on all occasions and in all subjects; but let it be ever tempered and softened by the wisely-directed experience of those who have passed over this stage and have arrived at the stage of sober thoughtfulness.

PERHAPS the most prominent feature of the greater part of the literature that has been pouring from the press during the last few years is the large number of books of biography. Biographies, autobiographies, reminiscences, lives, letters, literary remains, have been absorbed by the public in hundreds of thousands. There seems no limit to the appetite for them. And, strange to say, there seems to be no very great fastidiousness as to the quality of material which is produced. All the petty details of a great man—his littlenesses equally with his greatnesses—are devoured with avidity. There is something melancholy in this. It looks as though the object were, not to learn what is true greatness, what were the hidden springs of great thought, great action, but to analyse and dissect the lower parts of human nature—not to eliminate the alloy, but rather to make this the object of examination, not to learn from superior intellect and moral worth how we ourselves may attain to a nobler view of life, but to revel in the contemplation of the idiosyncracies, and even not seldom the actual faults of the great men of this world.

But yet, let us hope, that there is to this another side: that this depraved taste is not really wide-spread; that there are many who read of great men in a reverential spirit, kind to their faults, docile as to their virtues; willing to learn from them, to correct their own faults by witnessing the effects of these in others, and eager to apply to their own cases all that was found to be efficacious in helping those of whose lives we read.

We wrote a short time since on "how to read"; this reverential and liberal spirit

should ever surely be the attitude in which to contemplate the lives of those who have not yet been wholly explained to us. True, no criticism or abhorrence of vice can be too severe, but we do not here speak of the vices which are held up to us in the biographies of men and women, we speak only of their weaknesses.

It is only the great man that can really comprehend the great man. We should not lose sight of this. Superior intellects themselves recognize the value, and at the same time the difficulty, of understanding minds of large calibre. How many of those whom the world has called geniuses have striven hard to obtain clear views of their compeers? Look, for example, at the names of Carlyle's works—how many of them deal solely with this subject: "Frederick the Great"; "Heroes and Hero-Worship"; "Cromwell"; Essays on Goethe, Diderot, Johnson, Burns, Schiller? So too with De Quincey—Kant, Pope, Herder, Keats, and many others he wrote on. So too Matthew Arnold. So Macaulay. Our readers can, without difficulty, extend the list.

Biographies then, if we grant these propositions, are valuable, provided always that they are the products of competent minds, and are read in a proper spirit. And being so, they should form part of our course of reading. But there is this caution always to be borne in mind: no expounder must be considered infallible. There are some sentences of Coleridge's in reference to Shakespearean critics the vigor and beauty of which will serve to impress this caution upon our minds. "If all that has been written upon Shakespeare, by Englishmen, were burned, in the want of candles, merely to enable us to read one-half of what our dramatist produced, we should be great gainers." And again: "I grieve that every late voluminous edition of his works (Shakespeare's) would enable me to substantiate the present charge with a variety of facts one-tenth of which would of themselves exhaust the time allotted to me. Every critic, who has or has not made a collection of black letter books—in itself a useful and respectable amusement,—puts on the seven-league boots of self-opinion, and strides at once from an illustrator into a supreme judge, and blind and deaf, fills his three-ounce phial at the waters of Niagara; and determines positively the greatness of the cataract to be neither more nor less than his three-ounce phial has been able to receive."

Contemporary Thought.

"AFTER all," says Miss Frances Willard in *The Chautauquan* for May, "it doesn't so much signify what you may do as that you do it well, whatever it may be. For the value of skilled labor is estimated on a democratic basis, nowadays. President Eliot, of Harvard University, the cook in the Parker House restaurant, and Mary L. Boothe who edits *Harper's Bazar*, each receive \$4,000 per year."

FIRST go to the bottom of everything which you have to do. Know all its principles. If it be a trade, know not only its rules, but the reasons for them. If it be merchandise in raw materials, or in one or more manufactured articles, be sure to learn the whole process, from the planting of the seed or the digging of the ore, to the completed fabric. Do this by observation, conversation with the heads of departments, and with workmen in different specialties. This was the plan of the late William E. Dodge. —From Dr. J. M. Buckley's "Oats or Wild Oats."

WHY is the memory of Mrs. Browning loved beyond that of almost any poet who has sung? Because "the cry of the human" is so strong in that wondrous voice of hers. Why is the name carved deepest on the Republic's heart that of its martyr President? Because he gave their manhood back to four millions of slaves, and lived and toiled for his people's sake, "with malice toward none, with charity for all." Why was the lamentation well-nigh universal when under the sea flashed the telegraphic message, "John Stuart Mill is dead?" Because this quiet thinker lived for other men; because he "struck out from the centre," from himself, that pitiful pivot on which so many human wind-mills turn, and measured, in the swift flight of its benignant thought, the long radius between him and the remotest circle of human need; because, more than any other philosopher of his day, he labored for the time when "all men's weal shall be each man's care." —From "The Chautauquan."

THERE does exist another and inexhaustible source of wealth and progress, viz., new knowledge obtainable by means of scientific research. It is upon such knowledge, gained by experiments made to examine natural forces and substances, that we must sooner or later depend as a fundamental source of national prosperity. As fast as this knowledge is evolved by discoverers, it is applied in more immediately practical forms by numerous inventors, and then manufacturers and men of business use those practical realities in the production of wealth. This has been the order of events in the past, and will be in the future; this was the way in which we got wealth out of coal. Persons of narrow views on the subject will consider the above proposition vague and unpractical; but this order of things is a great fact, and unavoidable. We are the servants of Nature, and have no choice in the matter; we might as well hope to live without food as expect to advance in civilization without the aid of new knowledge. —From "A Scientific View of the Coal Question," by G. Gore, in the *Popular Science Monthly* for May.

MARGARET MARIA GORDON, writing from Nice to *The Home Chronicle*, says: "My father,

Sir David Brewster, had a strong dislike to cats; he said that he felt something like an electric shock when one entered the room. Living in an old mouse-ridden house, I was at last obliged to set up a cat, but on the express condition that it never was to be seen in his study. I was sitting with him one day, and the study door was ajar. To my dismay pussy pushed it open, and, with a most assured air, walked right up to the philosopher, jumped upon his knee, put a paw on one shoulder and a paw on the other, and then composedly kissed him! Utterly thunderstruck at the creature's audacity, my father ended by being so delighted that he quite forgot to have an electric shock. He took pussy into his closest affections, feeding and tending her as if she were a child. One morning, some years afterward, no pussy appeared at breakfast for cream and fish; no pussy at dinner, and, in fact, months passed on and still no pussy. We could hear nothing of our pet, and we were both inconsolable. About two years after, I was again sitting with my father, when, strange to say, exactly the same set of circumstances happened. The door was pushed gently open, pussy trotted in, jumped on his knee, put a paw on each shoulder, and kissed him. She was neither hungry, thirsty, dusty, nor footsore, and we never heard anything of her intervening history. She resumed her place as household pet for some years, till she got into a diseased state from partaking too freely, it was supposed, of the delicacy of rat-flesh, and in mercy she was obliged to be shot. We both suffered so much from this second loss that we never had another domestic pet." —From the *Leisure Hour*.

THE fact is that the reverence for beauty, genuine enough with men like Mr. Ruskin, is superficial with the multitude, whose real worship is one of comfort. Whenever there is a struggle between the things of the past and those of the present, it is easy to predict which will survive; for in this case fitness is always measured by comfort. Perhaps, after all, when the buildings and cities in which people live are concerned, it is unreasonable to wish it to be otherwise. It may be, as Hawthorne says somewhere in the *Marble Faun*, in speaking of the gloom and chill and inconvenience of the stone palaces in Italian cities, that a dwelling-place should never be built to last longer than forty or fifty years. It is probably more important that a house should be healthy and clean and adapted to the physical well-being of men who are to spend their days in it than that it should give mental pleasure to those who merely look at it from without. Workingmen living in the ugly suburbs of London, or in the red brick monotony of Christian and Catharine Streets in Philadelphia, which no man would go out of his way to look at, are doubtless better off than their fellows in Italian towns, though the latter may be settled in two or three large, damp rooms on the ground floor of old palaces which travellers come from afar to see. The few—a losing remnant in this case—overlook the wants of the people. Considering the subject dispassionately, we must admit that many of the changes which are fatal to mediæval beauty and quaintness are not wholly unnecessary or capricious. No one, while the memory of last summer's plague is still fresh, can deny, for example, that it is better to sacrifice the pictur-

esqueness of some of the narrow, dirty streets of Naples than the health and lives of thousands of Neapolitans. The majority of business men in London do not question the wisdom of the removal of Temple Bar, which has made their going to and coming from the city seem so much easier. It must be added, however, that those whose occupations do not lead them cityward wonder what great good has been done by destroying an old landmark, declared to be an obstruction in the street, and then blocking up the way with a new, meaningless monument. —*June Atlantic*.

AT first sight it seems reasonable to acknowledge that large, graded public schools, intended chiefly to force education on the class of minds that do not take to it readily of their own accord must be managed with more "system" and dry-as-dust routine than the kindergarten, and private schools, and academies, and colleges, intended for those who thirst for knowledge and are willing to pay for it and can give to it the leisure to absorb it slowly, thoughtfully, and successfully. But on second thought, it is evident that the other class are precisely the ones who need to have knowledge relieved of its dry-as-dustness—who, to retain a fact, must have it made strikingly picturesque to them. We have seen recently in manuscript a history whose chief recommendation was said to be that it had been "carefully adapted to the use of public schools." Of course "carefully adapted" meant that it had been arranged on the plan of giving only absolute facts, with "questions and answers," arranged to enable the teacher to "hear a recitation" from so many pupils in such a length of time. Of the nobler plan of teaching by topics, or lectures, giving as an insight into the slavery question and emancipation something besides the fact of the date when slaves were first "imported" into the United States and the date when Abraham Lincoln issued his emancipation proclamation, there is felt to be no possibility in large graded schools. But somehow, somewhere, and some time, something of the kind must and will be adopted. At present, interest is secured in the necessary knowledge by a scheme of written examinations perfectly exhausting to pupil and teacher; with results easily showing how "plain facts" are not nearly so clear to the average intellect as what we may call in the language of the day, decorative (not decorated) facts. The pupil taught by "question and answer" will inform you in a written examination that "the Salic law was a law by which no woman and no descendant of a woman, could come to the French throne," and if asked to "sketch the career of De Soto," will draw a map with the Mississippi River careering down the page. These were actual replies in an examination at the Girls' High and Normal School in Boston. That the peculiar cram of statistics thought necessary for a good, common, practical education is not necessary, is shown by the fact that the young lady who passed the highest examination for entrance at that school had received little more than two-years' drill in the "question and answer" methods; her education before that having been of the most desultory kind. She gave 99 per cent of correct answers, only failing in the mark for her handwriting; and it was said that none of her answers were marked anything but "perfect." —*The Critic*.

Notes and Comments.

WE have been asked to give information in regard to the Amended Scott Act—whether or not it is now in force. It is now in force and has been so since the assent given to it by the Lieutenant-Governor.

EDUCATORS will be glad to learn that Macmillan & Co. purpose issuing immediately an American edition of Fitch's admirable *Lectures on Teaching* with an Introductory Preface by President Hunter of the Normal College, New York.

The Chautauquan for June begins a series of timely articles on "American Museums"; Clarence Cook is preparing them—a guarantee of their value. He begins his papers with the Boston Museum. Dr. Felix Oswald argues ably for the Nicaragua canal declaring that "Nicaragua will compete with Switzerland, Italy, and winter resorts of Southern California, as well as with our trans-continental railways. Panama will compete with Cape Horn." "George Bancroft" is the subject of another article. In it the writer, Prof. W. W. Gist, calls attention to the positions of public trust which the historian has held, having served as collector at the port of Boston, as Secretary of the Navy under President Polk, as Acting Secretary of War, as Minister to England, and finally as Minister to Berlin.

WE confess we have not much sympathy with those who are asking "What shall we read?" They tell us nothing of the natural bent of their minds; of the character of their early education; of the subjects in the knowledge of which they feel themselves deficient; of the subjects upon which they are at present engaged; of the great authors they have already mastered; of those whom they have not yet studied; and yet they persist in asking "What shall we read?" As well might a patient write to a physician whom he had never consulted and ask "What shall I take?" To these questioners we would give the following advice: Go to some literary physician—himself a widely and deeply-read man, and, if possible, a specialist in the branches in which the questioner is most at home—go, we say, to such a literary physician, place your case in his hands, let him make his diagnosis and then prescribe what you shall read.

WE hardly know whether or not apologies are needed for devoting six columns of this issue to Ruskin. On the whole perhaps not. Ruskin's works, though yearly, even monthly becoming more accessible to the general public, are not yet household books. Up to within a very recent date their expensiveness was such as to make out of the question the possibility of nine-tenths of our population

possessing anything but an indirect knowledge of them. And this to a great extent is still the case. One of our reasons for inserting the extract from *The Seven Lamps of Architecture* was to give an example of a recognizedly beautiful style. Robert Louis Stevenson's article and the paper on "The Adjective in Literature" will have, perhaps, stimulated our readers to examine and appreciate this excellence.

THE object of the Saratoga Summer School of Methods is to bring the advantages of the Normal School and a discussion of improved methods of teaching within the reach of every teacher in the country. It is to be an institute and not a convention. Familiar talks will be given rather than stated lectures; questions from students encouraged; no study required; note-taking expected. Rest and recreation will be combined with facilities for self-improvement. The Faculty consists of *Practical Teachers*, who are to-day teaching in their various schools. They will present their *methods* in such a simple, familiar way, and so illustrate their lessons with apparatus, objects and pictures used in their work, that every student will be able to carry away ideas, plans and methods of teaching, such as can be immediately introduced into his or her school-room. Saratoga has been chosen for the Summer School, because of its acknowledged beauty, healthfulness, central location, convenience and cheapness of living. The same simplicity of dress and style of living are possible here as in a country village.—*New York School Journal*.

WE take the following powerful sentences from the June *Popular Science Monthly*:—We are beginning to hear lamentations over the realism of our time. Not only are the gods dead, God is dead. Art finds no place for Imagination, save in setting her to devise ways and means for a more complete photographic process. Among the crimes laid to the account of Science, *this* is not the least; indeed, perhaps this may sum them all, that she has taken away our Lord and will show us nothing in return but the geologic formation of a sepulchre. While this charge is unjust, radically unjust, it must be allowed that the manner of commendation employed by many advocates of science is responsible, in large measure, for our bread-and-butter attitude. The fault lies in the original constitution of certain men—not that they are scientists, but that they are small scientists; men for whom a formula, or a compound, or a root, or a fact whatsoever, is the end. To know the most names of the most classifications is to be saved, to apply chemistry in the manufacture of salable beer is to make "calling and election" sure. The devotion of these little men to science is not only at the expense of all that is highest, but is, as

was intimated, largely responsible for the realism over which so many weep. Men of science, that is to say *men* of science, are not accountable for deadness of soul. The wonder with which those early Greeks looked out upon the face of all things may not for one instant be compared with the wonder that fills the soul to-day before this stupendous universe. Because we have learned that color is not in sunset or rose, is there therefore no color! Is the marvel anywise diminished by knowing that, upon matter, so adjusted and so acting as the brain is adjusted and acts, all color depends? Because there is no sound in bell, or breeze, or ocean, is there therefore no sound? And wherein is the wonder of it diminished when we have learned the construction of the ear, its possible relation to a particular fold in the brain, and the necessity of this for all the harmonies that fill the soul with glory? Are we, the thinking, sorrowing, hoping selves, any the less real because *all* this thinking, all this sorrowing, and all this hoping depend in strictest sense upon that most highly organized form of matter, the human brain?

DAVID SWING, in *The Current*, speaking of Daniel Webster's education, makes the following general remark:—It does not seem that our highschools develop sufficiently an ability in the pupil to express his or her personal thought on the subject of the lesson. The lesson should be much like the "case" of the lawyer, or the "text" of a preacher—a kind of train-starter, by which a large mass of things is put into motion. When the outlines of a "case" came into the mind of Daniel Webster, an endless amount and variety of detail began to rise up out of the first rude outlines as the Bible's mustard tree sprang from the smallest of seeds. In the Dartmouth College case, in the oration on the Greek Revolution, in the Knapp murder trial, and in the famous speech against Hayne, nothing is so conspicuous as the absolute power of a mind to build up a grand temple out of rough rocks. It is difficult to determine what class of studies possesses the most power to move the mind into action, but it is probably those which most touch the heart and blend in the most possible manners with the common life of mankind. The languages, the literatures, the arts, the histories, the biographies, no doubt surpass the exact sciences in the formation of great men and great women. The mathematical facts of the world are valuable and so are the scientific facts, but in the composition of the world's thinkers and actors language, imagination, passion, sensibility, perform parts which cannot be equalled by any benefits mathematics can confer. Daniel Webster drew language from a constant reading of *The Spectator*; from that and similar books he drew much of his power of statement.

Literature and Science.

THE FLEET.

(ON ITS REPORTED INSUFFICIENCY.)
[Lord Tennyson, in the *London Times*.]

You—you—if you have failed to understand—
The Fleet of England is her all in all—

On you will come the curse of all the land,
If that Old England fall,
Which Nelson left so great—

This isle, the mightiest naval Power on earth,
This one small isle, the lord of every sea—
Poor England, what would all these votes be worth,
And what avail thine ancient fame of "Free,"
Wert thou a fallen State?

You—you—who had the ordering of her Fleet,
If you have only compass'd her disgrace,
When all men starve, the wild mob's million feet
Will kick you from your place—
But then—too late, too late.

THE LAMP OF MEMORY.

JOHN RUSKIN.

It is as the centralisation and protectress of this sacred influence [memory] that Architecture is to be regarded by us with the most serious thought. We may live without her, and worship without her, but we cannot remember without her. How cold is all history, how lifeless all imagery, compared to that which the living nation writes, and the uncorrupted marble bears! how many pages of doubtful record might we not often spare, for a few stones left one upon another! The ambition of the old Babel builders was well directed for this world: there are but two strong conquerors of the forgetfulness of men, Poetry and Architecture; and the latter in some sort includes the former, and is mightier in its reality; it is well to have, not only what men have thought and felt, but what their hands have handled, and their strength wrought, and their eyes beheld, all the days of their life. The age of Homer is surrounded with darkness, his very personality with doubt. Not so that of Pericles: and the day is coming when we shall confess, that we have learned more of Greece out of the crumbled fragments of her sculpture than even from her sweet singers or soldier historians. And if indeed there be any profit in our knowledge of the past, or any joy in the thought of being remembered hereafter, which can give strength to present exertion, or patience to present endurance, there are two duties respecting national architecture whose importance it is impossible to overrate; the first, to render the architecture of the day historical; and, the second, to preserve, as the most precious of inheritances, that of past ages.

It is in the first of these two directions that Memory may truly be said to be the Sixth Lamp of Architecture; for it is in becoming memorial or monumental that a true perfection is attained by civic and domestic

buildings; and this partly as they are, with such a view, built in a more stable manner, and partly as their decorations are consequently animated by a metaphorical or historical meaning.

As regards domestic buildings, there must always be a certain limitation to views of this kind in the power, as well as in the hearts, of men; still I cannot but think it an evil sign of a people when their houses are built to last for one generation only. There is a sanctity in a good man's house which cannot be renewed in every tenement that rises on its ruins: and I believe that good men would generally feel this; and that having spent their lives happily and honorably, they would be grieved at the close of them to think that the place of their earthly abode, which had seen, and seemed almost to sympathise in all their honor, their gladness, or their suffering—that this, with all the record it bore of them, and all of material things that they had loved and ruled over, and set the stamp of themselves upon—was to be swept away, as soon as there was room made for them in the grave; that no respect was to be shown to it, no affection felt for it, no good to be drawn from it by their children; that though there was a monument in the church, there was no warm monument in the heart and house to them; that all that they had ever treasured was despised, and the places that had sheltered and comforted them were dragged down to the dust. I say that a good man would fear this; and that, far more, a good son, a noble descendant, would fear doing it to his father's house. I say that if men lived like men indeed, their houses would be temples—temples which we should hardly dare to injure, and in which it would make us holy to be permitted to live; and there must be a strange dissolution of natural affection, a strange unthankfulness for all that homes have given and parents taught, a strange consciousness that we have been unfaithful to our fathers' honor, or that our own lives are not such as would make our dwellings sacred to our children, when each man would fain build to himself, and build for the little revolution of his own life only. And I look upon those pitiful concretions of lime and clay which spring up in mildewed forwardness out of the kneaded fields about our capital—upon those thin, tottering, foundationless shells of splintered wood and imitated stone—upon those gloomy rows of formalised minuteness, alike without difference and without fellowship, as solitary as similar—not merely with the careless disgust of an offended eye, not merely with sorrow for a desecrated landscape, but with a painful foreboding that the roots of our national greatness must be deeply cankered when they are thus loosely struck in their native ground; that those comfortable and unadorned dwellings are the signs of a great

and spreading spirit of popular discontent; that they mark the time when every man's aim is to be in some more elevated sphere than his natural one, and every man's past life is his habitual scorn; when men build in the hope of leaving the places they have built, and live in the hope of forgetting the years that they have lived; when the comfort, the peace, the religion of home have ceased to be felt; and the crowded tenements of a struggling and restless population differ only from the tents of the Arab or the Gipsy by their less healthy openness to the air of heaven, and less happy choice of their spot of earth; by their sacrifice of liberty without the gain of rest, and of stability without the luxury of change.

This is no slight, no consequenceless evil: it is ominous, infectious, and fecund of other fault and misfortune. When men do not love their hearths, nor reverence their thresholds, it is a sign that they have dishonored both, and that they have never acknowledged the true universality of that Christian worship which was indeed to supersede the idolatry, but not the piety, of the pagan. Our God is a household God, as well as a heavenly one; He has an altar in every man's dwelling; let men look to it when they rend it lightly and pour out its ashes. It is not a question of mere ocular delight, it is no question of intellectual pride, or of cultivated and critical fancy, how, and with what aspect of durability and of completeness, the domestic buildings of a nation shall be raised. It is one of those moral duties, not with more impunity to be neglected because the perception of them depends on a finely toned and balanced conscientiousness, to build our dwellings with care, and patience, and fondness, and diligent completion, and with a view to their duration at least for such a period as, in the ordinary course of national revolutions, might be supposed likely to extend to the entire alteration of the direction of local interests. This at the least; but it would be better if, in every possible instance, men built their own houses on a scale commensurate rather with their condition at the commencement, than their attainments at the termination, of their worldly career; and built them to stand as long as human work at its strongest can be hoped to stand: according to their children what they have been, and from what, if so it had been permitted them, they had risen. And when houses are thus built, we may have that true domestic architecture, the beginning of all other, which does not disdain to treat with respect and thoughtfulness the small habitation as well as the large, and which invests with the dignity of contented manhood the narrowness of worldly circumstance.

I look to this spirit of honorable, proud, peaceful self-possession, this abiding wisdom of contented life, as probably one of the chief

sources of great intellectual power in all ages, and beyond dispute as the very primal source of the great architecture of old Italy and France. To this day, the interest of their fairest cities depends, not on the isolated richness of palaces, but on the cherished and exquisite decoration of even the smallest tenements of their proud periods. The most elaborate piece of architecture in Venice is a small house at the head of the Grand Canal, consisting of a ground floor with two storeys above, three windows in the first, and two in the second. Many of the most exquisite buildings are on the narrower canals, and of no larger dimensions. One of the most interesting pieces of fifteenth century architecture in North Italy, is a small house in a back street, behind the marketplace of Vicenza; it bears the date 1481, and the motto, *Il nest. rose. sans. epine*; it has also only a ground floor and two storeys, with three windows in each, separated by rich flower-work, and with balconies, supported, the central one by an eagle with open wings, the lateral ones by winged griffins standing on cornucopia. The idea that a house must be large in order to be well built, is altogether of modern growth, and is parallel with the idea, that no picture can be historical, except of a size admitting figures larger than life.

I would have, then, our ordinary dwelling-houses built to last, and built to be lovely; as rich and full of pleasantness as may be, within and without; with what degree of likeness to each other in style and manner, I will say presently, under another head; but, at all events, with such differences as might suit and express each man's character and occupation, and partly his history. This right over the house, I conceive, belongs to its first builder, and is to be respected by his children; and it would be well that blank stones should be left in places, to be inscribed with a summary of his life and of its experience, raising thus the habitation into a kind of monument, and developing, into more systematic instructiveness, that good custom which was of old universal, and which still remains among some of the Swiss and Germans, of acknowledging the grace of God's permission to build and possess a quiet resting-place.

In public buildings the historical purpose should be still more definite. It is one of the advantages of Gothic architecture—I use the word Gothic in the most extended sense as broadly opposed to classical—that it admits of a richness of record altogether unlimited. Its minute and multitudinous sculptural decorations afford means of expressing, either symbolically or literally, all that need be known of national feeling or achievement. More decoration will, indeed, be usually required than can take so elevated a character; and much, even in the most

thoughtful periods, has been left to the freedom of fancy, or suffered to consist of mere repetitions of some national bearing or symbol. It is, however, generally unwise, even in mere surface ornament, to surrender the power and privilege of variety which the spirit of Gothic architecture admits; much more in important features—capitals of columns or bosses, and string courses, as of course in all confessed bas-reliefs. Better the rudest work that tells a story or records a fact, than the richest without meaning. There should not be a single ornament put upon great civic buildings, without some intellectual intention. Actual representation of history has in modern times been checked by a difficulty, mean indeed, but steadfast: that of unmanageable costume; nevertheless, by a sufficiently bold imaginative treatment, and frank use of symbols, all such obstacles may be vanquished; not perhaps in the degree necessary to produce sculpture in itself satisfactory, but at all events so as to enable it to become a grand and expressive element of architectural composition. Take, for example, the management of the capitals of the ducal palace at Venice. History, as such, was indeed entrusted to the painters of its interior, but every capital of its arcades was filled with meaning. The large one, the corner stone of the whole, next the entrance, was devoted to the symbolisation of Abstract Justice; above it is a sculpture of the Judgment of Solomon, remarkable for a beautiful subjection in its treatment to its decorative purpose. The figures, if the subject had been entirely composed of them, would have awkwardly interrupted the line of the angle, and diminished its apparent strength; and therefore in the midst of them, entirely without relation to them, and indeed actually between the executioner and interceding mother, there rises the ribbed trunk of a massy tree, which supports and continues the shaft of the angle, and whose leaves above overshadow and enrich the whole. The capital below bears among its leafage a throned figure of Justice, Trajan doing justice to the widow, Aristotle "che die legge," and one or two other subjects now unintelligible from decay. The capitals next in order represent the virtues and vices in succession, as preservative or destructive of national peace and power, concluding with Faith, with the inscription "Fides optima in Deo est." A figure is seen on the opposite side of the capital, worshipping the sun. After these, one or two capitals are fancifully decorated with birds (Plate V.), and then come a series representing, first the various fruits, then the national costumes, and then the animals of the various countries subject to Venetian rule.

Now, not to speak of any more important public building, let us imagine our own India House adorned in this way, by histor-

ical or symbolical sculpture: massively built in the first place; then chased with the bas-reliefs of our Indian battles, and fretted with carvings of Oriental foliage, or inlaid with Oriental stones; and the more important members of its decoration composed of groups of Indian life and landscape, and prominently expressing the phantasms of Hindoo worship in their subjection to the Cross. Would not one such work be better than a thousand histories? If, however, we have not the invention necessary for such efforts, or if, which is probably one of the most noble excuses we can offer for our deficiency in such matters, we have less pleasure in talking about ourselves, even in marble, than the Continental nations, at least we have no excuse for any want of care in the points which insure the building's endurance. And as this question is one of great interest in its relations to the choice of various modes of decoration, it will be necessary to enter into it at some length.

The benevolent regards and purposes of men in masses seldom can be supposed to extend beyond their own generation. They may look to posterity as an audience, may hope for its attention, and labor for its praise: they may trust to its recognition of unacknowledged merit, and demand its justice for contemporary wrong. But all this is mere selfishness, and does not involve the slightest regard to, or consideration of, the interest of those by whose numbers we would fain swell the circle of our flatterers, and by whose authority we would gladly support our presently disputed claims. The idea of self-denial for the sake of posterity, of practising present economy for the sake of debtors yet unborn, of planting forests that our descendants may live under their shade or of raising cities for future nations to inhabit, never, I suppose, efficiently takes place among publicly recognized motives of exertion. Yet these are not the less our duties; nor is our part fitly sustained upon the earth, unless the range of our intended and deliberate usefulness include not only the companions, but the successors, of our pilgrimage. God has lent us the earth for our life; it is a great entail. It belongs as much to those who are to come after us; and whose names are already written in the book of creation, as to us; and we have no right, by anything that we do or neglect, to involve them in unnecessary penalties, or deprive them of benefits which it was in our power to bequeath. And this the more, because it is one of the appointed conditions of the labor of men that, in proportion to the time between the seed-sowing and the harvest, is the fulness of the fruit; and that generally, therefore, the farther off we place our aim, and the less we desire to be ourselves the witnesses of what we have labored for, the more wide and rich will be the measure of our success.

Educational Opinion.

ADDRESS OF PRESIDENT NELLES AT VICTORIA UNIVERSITY CONVOCATION, COBOURG, WEDNESDAY, MAY 13th, 1885.

GENTLEMEN OF THE SENATE AND MEMBERS OF CONVOCATION:—

You will, perhaps, expect me to offer to-day some remarks on the present state of higher education in the Province of Ontario, and especially in relation to our own university. I shall not attempt to argue, in all its bearings, what we are wont to call the University Question, but content myself with touching upon some particular phases of the subject, at least so far as to define my own position, and without directly controverting what others may have said. I desire, as far as possible, to avoid a controversial tone, feeling convinced that we shall make more progress toward a satisfactory result, by a calm and conciliatory interchange of views, than by many volumes of angry rhetoric. As the *Post-Laureate* says of another great educational problem:

"More soluble is this knot by gentleness than war."

If I have the misfortune to differ from some good friends of our university, they will of course grant that this is not altogether my fault, seeing that they differ as much from me as I do from them. And if I seem to put a little strain upon sentiments and associations which our Alumni naturally cherish, they will remember that no one has more reason than I to feel the force of those associations, and that I would not be likely in any way to disturb them except from an honest regard for the educational interests of the country.

There is always some difficulty in discussing educational questions from the fact that, while few persons study them, every one seems to think that he knows all about them. I notice in our country to-day three or four currents of sentiment, each of which appears to me to set in the wrong direction. First, there is the unhappy notion of those who disparage the advantages of higher learning, and who as a natural consequence are hostile, or at least apathetic, in regard to all appeals for the necessary funds, whether those appeals be made to the Legislature or to private individuals. There is, secondly, the opinion of some ill-informed people who imagine that a university can be adequately sustained upon twenty five or thirty thousand dollars a year, and with such an endowment can successfully compete with neighboring universities having a yearly income of five or six times that amount. Sometimes the difference in endowment is supposed to be made up by ecclesiastical influences—influences desirable enough when they secure to a seat of learning the

resources requisite for efficiency, but not very desirable otherwise. Thirdly, there is the mistake of those who would give higher education an unduly practical turn, or what they erroneously consider to be practical, throwing out of doors, or at least far into the back-ground, the ancient languages and literature, with those higher philosophical inquiries, in which the ancients were the pioneers, and are still indispensable guides. And there is lastly the error of those who, either as a matter of preference or of expediency, would restrict the work of our national university to what are called secular studies, leaving all religious teaching and discipline to the pulpit and the Sunday School.

I shall now discuss these several views in detail, but the tenor of my remarks will sufficiently indicate my own opinion, both on the general questions, and on some particular educational measures which are now before the country. I wish, however, to remark at the outset that the great matter with me is neither federation of colleges, nor removal of Victoria College from the town of Cobourg, but a satisfactory system of higher education for the Province of Ontario, and an honorable and effective relation to that system on the part of the Methodist Church. I desire, for my part, to rise, as far as possible, above both local and sectarian considerations, and to keep in view the great underlying principles which governed our fathers in establishing this seminary of learning, principles of a very broad and patriotic character, and which are even more sacred and enduring than either Cobourg and Kingston limestone, or the inviting grounds of a Toronto park.

"At the revival of learning," as some one has said, "Greece arose from the grave with the New Testament in her hands." This picture of Greece with the New Testament in her hands, may be taken, by an enlarged interpretation, as an appropriate symbol of a true university. Greece—that is, science, literature, philosophy, and art; in a word, all human culture on its secular side. The New Testament—that is, the Christian religion; human development and perfection on its spiritual or divine side. Both taken together are essential to a well-rounded type of education, as both are essential to individual and national welfare. It is one of the glories of Christianity that it can stand unabashed and unshaken in the presence of all forms of scholarly research, and make them all tributary to its progress, and it is one of the great facts in the history of the universities that they have always recognized Christianity as an indispensable factor in the work of education. But the Christian Church has at length so divided itself into sections, and, on the other hand, the subjects of university teaching have so multiplied and extended, that the relation of the Church to the University has become a difficult prob-

lem to solve. In the Dominion of Canada, and especially in this Province of Ontario, we have long had a perpetual and embarrassing conflict on this great matter. Every sect cannot have a genuine university, and the Legislature cannot recognize the claims of one sect over another. And thus between the necessities of the State University, and the rival necessities of a number of denominational universities, we have at last reached what may be called a kind of dead-lock in our educational progress. We may, therefore, well begin to inquire, and the growing spirit of Christian union enables us to inquire with hopefulness, whether all the Churches of Ontario cannot combine in one national university, and with advantage to the common interests of science and religion. Those who distrust or oppose such a measure seem to me to raise imaginary obstacles, and also to fail in estimating the increasing extent of university work, and the consequent necessity of large endowments, such endowments as we can only secure in this Province by concentrating all our available resources. Such persons seem to forget that, if we keep our universities poor, we shall have poor universities in more senses than one. They also forget that in so far as any religious body stands aloof from the national system of education it not only deprives itself of advantages to which it is fairly entitled, but does what it can both to weaken and unchristianise that system. "Let us beware," says Mr. Gladstone, "of a Christianity of isolation."

The extension of university work arises chiefly from the progress of the physical sciences; but we have to remember that the newer sciences, or departments of science, have not rendered obsolete or useless the old academic studies, although they have deprived the latter of the monopoly which they once enjoyed. We have to provide for the ancient as well as the modern. Even the old classical and metaphysical departments are far from being stationary, but involve both new lines and new methods of research. I have no need to set up any special defence of classical studies as against modern science and literature. There is no proper opposition between the two forms of discipline, and no occasion for exalting the one at the expense of the other, but when the popular sentiment runs strongly in one direction, as it now appears to do, it is perhaps as well for us to insist a little more on that which is in danger of being unduly displaced. We may, indeed, value too highly the study of ancient literature, but we may also over-estimate, or mistakenly estimate, the value of physical science. True culture is not one-sided, but many-sided, consisting as Butler says of human nature, "not of some one thing alone, but of many other things besides." The popular current of to-day will, in all probability,

soon go rebounding in the opposite direction, according to that salutary law of action and reaction which govern the river of human progress, as well as other flowing streams. And when men tell us that it is better to study nature than literature, as the works of God are nobler than the works of man, we can but use the decisive argument which I once heard employed by Prof. Goldwin Smith, and say in reply, that man is also one of the works of God, and the highest one known to us, and that the study of man requires the study of his language and literature, and, among others, the language and literature of Greece. It is noteworthy to find the following language used by Todhunter, whose specialty is not Greek but mathematics:—"A decline in the state of Greek scholarship implies more than the failure of esteem for the most valuable and influential of all languages; it involves with it a gradual but certain decay of general culture, the sacrifice of learning to science, the neglect of the history of man and of thought for the sake of facts relating to the external world." We may, indeed, deny that Greece fully represents the varied wealth of modern learning, but we cannot deny that Greece gave the first great impulse out of which all modern culture has sprung, and beyond which, in some forms of excellence, no advancement has since been made. "Earth," says Emerson, "still wears the Parthenon as the best gem upon her zone." For many minds of the highest order, Homeric studies and Homeric inspiration have lost none of their interest and power. All philosophy, according to a great modern metaphysician, is but Plato rightly interpreted, and the most eminent French moralist of our day announces himself as the disciple and expounder of Aristotle. What is good in these ancient writings agrees with the Gospel, and therefore confirms it; what is false or defective shows the need of the Gospel, and therefore confirms it in another way. The spirit of the olden time, whether from the plains of Marathon or the halls of the academy, still runs through the generations of men and "enriches the blood of the world." There is no break, and except by a return of barbarism, there can be none, in the continuity of the world's intellectual life. Men may come and men may go, but this goes on forever. The stream, as it sweeps down the ages, may receive new contributions, but it will never forget or lose sympathy with the primal waters upon the far-off mountain side. More and more, and in all departments of learning, men are employing the historical method as an instrument of progress, running backward that they may the better leap forward. Not satisfied with the ordinary records of history, they are turning with growing interest to the obscure relics of pre-historic times, the ruins of ancient cities, and the customs and traditions of savage tribes, seeking everywhere to find the human footprints on the

sands of time—now in the wilds of America, now in the dark continent of Africa, and now "where the gorgeous East showers on her kings barbaric pearl and gold."

The history of thought, not less than other forms of history, still returns upon us, again and again, under new points of view, and with larger revelations; but the history of thought proper begins with Greece, and it can no more dis sever itself from that mother-wit of all the schools, than the child can cease to feel the hereditary bias of natural parentage. Back to Kant is the urgent cry lately set up among modern metaphysicians; back to Plato is a cry equally urgent; if indeed it has ever been possible to get wholly away from either the one or the other. Nor is it merely with a view to what some would call barren speculation that men counsel thus, for our eminent and orthodox theologians use the same language. It is in the interests of religion that Prof. Flint and others speak, when they tell us to seek in Plato an antidote against this modern monotony of pessimism, that most melancholy of all phases of human thought,

" . . . Whose cogitations sink as low
As, through the abysses of a joyless heart,
The heaviest plummet of despair can go."

By a diligent study of these grand old masters, with their enduring "majesties of light," we are enabled to counterpoise a narrow materialistic empiricism, which, in an age like ours, inclines to a kind of usurpation in the kingdom of knowledge. The discoveries of natural science seem to reach the masses sooner, and more beneficially, than philosophic speculations; but, sooner or later, they both alike travel down into the hearts and homes of the people, interpenetrating each other for good, and sometimes, as in our day, contending in their encounter for the mastery, like the fresh waters and the salt, where a great river meets the rising tide of the sea. All honor to those teachers of physical science who are doing such wonderful things for the promotion of human comfort, and for what Bacon terms "the relief of man's estate"; but equal honor to those interpreters of the spiritual order, who reveal to us the eternal realities behind the shadows of time; who teach us to remember that man does not live by bread alone, and that Lazarus in his rags feeding upon crumbs may be nearer to God than Dives in his palace though clothed in fine linen and faring sumptuously every day. But no regard for the old system of aademic drill can blind our eyes to the fact that the educational problem and university work have undergone an immense transformation. The physical and so called practical sciences have come to the front with multiplied claims and attractions that cannot be resisted, and should not be resisted. They combine with those historical researches to which I have already referred; they give new and fruitful lessons in the laws of health, the origin, the prevention,

and the cure of disease, including many ills of a moral kind; they seek to remould the institutions of society; they assert themselves effectively in the several provinces of moral and religious truth; they throw floods of light, and sometimes very perplexing cross-lights, upon the works and ways of God; and they have become a necessary study, if not for all Christian ministers, most certainly for all Christian Churches, and especially for those Christian scholars who are called upon to vindicate the claims of our holy religion. Every university worthy of the name must not only furnish instruction in what is known of these sciences, but should, if possible, make provision for original investigations. And beyond all these, we must add such subjects as comparative philology and comparative religion, together with the study of what Macaulay calls the most splendid and the most durable of the many glories of England, our own magnificent English literature, now taking a new and well-deserved position in the curriculum of every university.

Thus, then, between the ancient learning and the modern learning, the physical sciences and the moral sciences, with the innumerable sub-divisions of these, and with other forms of inquiry seeking to determine and reconcile the relations of these provinces to each other, the range of university work widens and stretches out towards illimitable fields of study. The ever-enlarging proportions of the modern university call for funds and appliances commensurate with the variety and extent of the work to be done. It may be said that young men at college do not need to cover all this wide field of study, and are in fact not able to do so. This fact rather increases than lessens the difficulty, for it necessitates many special courses of study, and therefore an increased number of teachers, together with a greater variety of buildings, libraries, collections, and other appliances. We may hold different views as to the wisdom of so much specialization, and of making room for such a range of elective and optional work, but the necessity is forced upon us. We cannot prevent the growth of science and literature, even if we would; and as no student can master all subjects within an undergraduate or even a post-graduate curriculum, we are compelled to allow a division of labor. In the days of Methuselah it could have been different. Then men lived a thousand years, and had ample time to cover a full systematic course of all known forms of learning. Four years could then have been given to the ancient languages, four to the modern languages, four to the natural sciences, and four to metaphysics, and so on for about fifty years of college life, and a graduate, even at that age, would have counted for a boy. But there is no possible mathematical formula for crowding our modern encyclopædia into the contracted space of a postdiluvian curriculum.

(To be continued.)

TORONTO:

THURSDAY, MAY 28, 1885.

COMPOSITION IN SCHOOLS.

PERHAPS no subject has been more slighted in schools than composition. It is true "compositions" are sometimes exacted of children by teachers, but as such exercises are generally without previous training they are imperfectly done and soon become so irksome that they are abandoned. Yet the art of written expression if properly taught and assiduously cultivated can be made as pleasant as oral composition or talking. The same general method should be adopted in both. We could never teach a child to talk by giving it a subject upon which it must talk for ten minutes or half an hour. Children learn from models how to talk. These models are their companions, and the child's skill in talking is in proportion to the effort he makes to imitate others. In early childhood, every one attempts to lead it to repeat words, and it gradually becomes the proud possessor of the whole vocabulary of its young companions. This encouragement, however, is too often dropped as soon as the child has learned to speak, and the learning process goes on unconsciously, but if the child be encouraged to talk, and carefully watched, its language will become fluent and as pure as its teacher's, its resources of expression will be almost wonderful, and its general intelligence will be greatly increased.

Composition must be learned in the same way, and should be taught in a somewhat similar manner. Children should be induced to write down what they have to say on any subject, or what they have heard others say. In other words, a child's first composition should be confined to transferring portions of his conversation to paper. Continued practice at this will give him as great facility in expressing himself in written language as in oral language. Faults may be pointed out in his composition as in his conversation, and much of what is called grammar may be imparted in unscientific language to a child, so that without much trouble he can be made familiar with correct expression, and have it so fixed by practice as to become habitual. The composition should often take the form of letters, confining them at first to the conversational

style and gradually introducing the technical form required in a letter.

As the child advances in his classes he should be gradually trained in sentence-building as language lessons under the guidance of the teacher. The sentence should express the child's own thoughts on some familiar object and may be voiced, improved, or manipulated in various ways by the suggestions of the teacher. Much good may be derived from epitomizing or re-writing stories read by, or to the children, and comparing their productions with the original, and occasionally exercises should be given to stimulate the child's invention and imagination by requiring him to compose original narratives, stories, or descriptions, taking care to make the tasks as simple as possible. Composition taught in this way, will be gradual but effective: by a little judicious care the teacher will be able to make the child familiar with the correct form of sentences, the use of capitals, punctuation, paragraphs, and the proper use of words. The process is slow, but "art is long," and the discipline must be undergone if success and excellence are aimed at in composition as in any other art. They write best who have written most, and long practice is the price paid by old or young for skill in writing.

BOOK REVIEW.

The Common School Compendium; for Home Students and Teachers. By Mrs. L. J. Lanphere, Des Moines. 253 pp \$1.25.

The aim and scope of this book, which seems to be the result of conscientious labor, are best described in the following words of the author:—

"*The Common School Compendium* is primarily designed as a reference and review book for 'Chautauquans' and others pursuing courses of home study. It also aims to be serviceable to any person who could profit by finding the kernel of information contained in the school books, divested of the husk of unnecessarily lengthened detail of illustration and example.

"As above stated this compendium embraces every minutest essential feature of common school study, including mathematical, physical and political geography, with maps; all rules for application of the fundamental principles of arithmetic, together with fractions, denominate numbers, percentage in all its branches; interest, insurance, banking, etc., besides alligation and mensuration; the several departments of grammar, with a fine list of abbreviations, and an extended historical sketch of the beginning and growth of both ancient and modern literature; natural history, under the various heads of astronomy, meteorology, natural philosophy, geology, zoology, botany and physiology; the book closing with a comprehensive outline history of the important nations of the world.

"As a ready means of keeping the memory fresh and bright on the main points of their work, teachers will find *The Common School Compendium*

unsurpassed; while to mothers who are chagrined at finding themselves 'rusty' on the work of their school days, and their little ones fresh from the school-room capable of being their instructors—to that large class of intelligent adults in this new country, who, regretting the denial of school privileges in their youth, would gladly welcome a quick means of supplying deficiencies of education even now—as well as to the thousands of young men and women who must labor for bread during the hours the doors of the school-room stand open, this book may safely be commended as exactly the help each and every one needs."

The book is one, however, we cannot recommend very highly except as a work of reference. For one who has not read fuller treatments of its various subjects than those given in the book, the concise statements it contains can have no true educational value. Many who have already mastered the subjects will find these statements bald and lifeless. The book is prettily bound, has a good map, and is badly printed.

BOOKS RECEIVED.

Our Little Men and Women: June, 1885. Boston: D. Lothrop & Co. \$1.00 a year.

Haultain, T. Arnold, M.A.; *The War in the Sudan and the Causes which Led to it, with Short Biographical Sketches of the Principal Personages Engaged.* Illustrated. Toronto: "Grip" Printing and Publishing Company, 1885. 137 pp.

Rawlinson, George, M.A., Camden Professor of Ancient History, Oxford; Canon of Canterbury Cathedral. *Egypt and Babylon—from Sacred and Profane Sources.* New York: Charles Scribner's Sons; Toronto: William Briggs. 329 pp. \$1.50.

Table Talk.

HUXLEY, the English scientist, has just celebrated his sixtieth birthday. He is one of the useful men whom the world regrets to see growing old.

RANDOLPH ROGERS, the noted American sculptor, who has resided in Rome for a number of years, by his will leaves all his art collections, casts, and a number of his original works to the University of Michigan.

It is reported that President McCosh intends resuscitating *The Princeton Review*, and to identify it more closely with Princeton College. Every college of the rank of Princeton should maintain a periodical which would be regarded as the authoritative medium for the expression of college opinion and thought.

PRESIDENT F. LOUIS SOLDAN has about perfected the preliminary arrangements for the next meeting of the National Educational Association, which will take place at Saratoga, July 14-18, and it promises to be both interesting and profitable. Arrangements have already been perfected by which board at the hotels can be had at from \$2.00 to \$3.00 per day.

JEAN INGELOW has just published in London a new volume of "Lyrics." They are said to show much of that power which marked her earlier

verse. She is fifty-five years old, which, reckoning by Longfellow, Holmes, Whittier, Tennyson, Browning, and other of her contemporaries, should be about her meridian.

IN 1878 the New York Free Circulating Library was organized by a few benevolent ladies, who proposed to circulate about 1,500 books per annum amongst the poor of their acquaintance. Last year it circulated about 95,000 volumes promiscuously, and lost only three, though no guarantee for the return of the books is exacted. Each of ten similar libraries scattered over the island would, it is thought, be able to circulate 150,000 volumes a year. More money is needed to run the Bond Street Library with, and unless it be raised, the building cannot be kept open during the summer. The annual income is \$3,500, the expenses \$12,000. Mr. Andrew Carnegie, one of the Patrons of the Library, added \$4,000 last week to his original gift of \$1,000, and thus became a Founder. Other subscriptions aggregating over \$1,000 were made at the same time.

"THE Earl of Lytton, better known in literature as 'Owen Meredith,' has just begun the publication of a satire named 'Glenaveril.' The poem is to be in six books, of which the first is issued in a neat paper volume by Messrs. D. Appleton. Canto III., 'The World,' shows Glenaveril taking his first glimpse of political life, and gives the author a chance to make pen-portraits of the leaders of Parliament, under fictitious names. It requires no great ingenuity to guess who are satirized; and the key, as we guess, is as follows: Cavellius—the Marquis of Salisbury; Glaucus—Earl Granville; Argyllus—the Duke of Argyll; Balbo—John Bright; Casca—Joseph Chamberlain; Historicus—Sir William Vernon Harcourt; Grandevus—Gladstone. The author's Tory bias is evident in every line, but there is just truth enough in his satire to make it sting, even when it is most unjust. The poem will doubtless make a sensation in English political circles."—*New York Examiner*.

ARCHIBALD FORBES, the English war correspondent, sketches Wolseley in *The English Illustrated Magazine* for May. He makes an effort to put his subject upon as high a pedestal as he can without making himself ridiculous, and, though admitting that Wolseley's quality has not yet been thoroughly tested in a great campaign against commanders of civilized nations, he implies more than he says by mixing up the names of Wolseley, Grant, Moltke, Lee, Gourko, Skobelev, and others on the same page. Mr. Forbes, in his humble judgment, opines that the warfare of the last thirty years has produced only two men who might be called "heaven-born soldiers" or men "with a genius for war." These two, he thinks, are Skobelev and Stonewall Jackson. He relegates Grant, Lee, Sherman, and Gourko to the rank of "more or less exceptionally able soldiers." He says that Moltke, while a master of the art of war, has had his tasks simplified "by the absence of any chiefs of inspiration from high commands in the armies of the worsted powers."

"MISS GORDON," says the *N. Y. Tribune*, "has received from the British War Office the last volume of General Gordon's diary. The Journal is written on the back of telegraph forms, and the

French, business-like, printed words on one side, 'Service télégraphique de l'Égypte et du Soudan,' present a contrast to the flowing, firm writing inscribed day by day on the other side. There are few erasures, no sign of hurry or flurry, no blots on the pages. Every now and then they are adorned with quaint drawings, humorously conceived, of the scenes that the besieged General imagines are passing in London. A conversation between Lord Derby and Lord Granville, in an elegantly furnished apartment, of which he is the subject, is the theme of one of these sketches. Turbaned Eastern figures in London drawing-rooms furnish another. Cuttings from newspapers dealing with his position or chronicling some popular outburst of feeling for him, appear also pasted in the journal. Miss Gordon has just received a letter from him from Khartoum, in which, committing himself to God's will, he says, 'I am quite happy, and, like Lawrence, have tried to do my duty.'"

NEWS comes from Weimar, says *Life* (London), that Walter von Goethe is dead. He was the grandson of the poet, and with him becomes extinct the famous name. His father was the child of Christiana Pulpius, whom Goethe married, and so in German law legitimized his boy, to whom he was intensely devoted. Many in Weimar remembered the son of the author of "Faust," and the likeness between father and child was startling. Walter, who has just died, studied music under the famous Mendelssohn, but he never made any name for himself, and lived a most retired life. He was subject to fits of melancholy, and would brood for days over his father's misfortune, illegitimacy. To him had descended all those rare and wonderful art collections which his grandfather had accumulated, and it was the one care of his life to tend them and watch over them. Indeed, he carried his affection to the most morbid limits, for he would not allow strangers to gaze upon the holy relics; they were too sacred for the common view. At the time of writing it is uncertain what will become of these priceless collections. There are numerous heirs on the Pulpius side of the family, and they all lay claim to them.

MR. JAMES MONTGOMERY STUART, says the *Mail and Express*, has just published a little volume of "Reminiscences and Essays," in which he quotes a literary opinion of Macaulay's agent a fellow-historian. "Visiting Lord Macaulay," he says, "just at the time when the first instalment of Carlyle's *Life of Frederic* was published, I found him engaged in the perusal of the opening chapters. His wrath—I can use no milder word—against Carlyle's style was boundless. He read aloud to me four or five of the most Carlylean sentences, and then throwing the book on the library table exclaimed: 'I hold that no Englishman has the right to treat his mother-tongue after so unfilial a fashion.' . . . Before a week had elapsed I was again at Holly Lodge, and he at once recurred to Carlyle's history. 'Pray read it,' he said, 'as soon as you can find time. Of course I have not got, and never shall get, reconciled to his distortions and contortions of language; but there are notwithstanding passages of truly wonderful interest and power, and in the infinite variety of new his-

torical facts, and in the delight and instruction they afford, if my first feeling has been that of annoyance at the strange way of telling the story, my second and permanent feeling is one of gratitude that—even in such a way—the story has been told.'"

JAMES RUSSELL LOWELL unveiled the bust of Coleridge, the poet, in Westminster Abbey, on May 7th. The bust was placed between those of Shakespeare and Campbell. Previous to the ceremony of the unveiling of the bust a preliminary gathering was held in the Chapter House. Besides Lord Chief-Justice Coleridge and Baron Houghton, there were present Lord Alder, Canon Farrar, Robert Browning, Professor Blackie, and the whole Coleridge family, including the grandson and granddaughter of the poet. Many members of the House of Commons, noblemen, bishops, deacons, and a large number of Americans were in attendance. Dean Bradley and Mr. Lowell entered the Chapter House arm-in-arm. The Dean made a short speech in which he said that he heartily sympathized with the object of the meeting. He paid a high tribute to Mr. Lowell and said that he was eminently fitted to perform the duty of unveiling the statue. The ceremony, he said, would add another link to the many that already bound together England and America. Mr. Lowell replied that he would have preferred that the task of unveiling the statue might be entrusted to worthier hands, but the fact that the bust is a gift of the Rev. Dr. Mercer, of Rhode Island, through his executrix, Mrs. Pell, supplied that argument of fitness which would otherwise have been absent. He continued: "All the waters of the Atlantic cannot wash out of the consciousness of either nation that we hold our intellectual property in common. The literary traditions and fame of those who shed lustre upon our race remain an undivided inheritance. Coleridge's works are a companion and teacher in the happiest hours of our youth, and in old age recall the radiant images of youth which we have lost. Surely there are no friends so constant as poets. Among them none are more faithful than Coleridge. Just fifty-one years ago I became possessed of a pirated American reprint of Coleridge, Shelley and Keats, and I trust I may be pardoned for the delight I took in it. Coleridge was a metaphysical teacher and interpreter whose services are incalculable." Mr. Lowell said that he admired especially "The Ancient Mariner," far more indeed than "Christabel." Coleridge was a man of artless simplicity and yet a finished scholar, although not exact. He owed much to the poetry of others, but most to his own native genius. He was picturesque in the best sense of the term. Mr. Lowell concluded: "This is neither the time, nor place, to speak of Coleridge's conduct to himself, his family, or the world. He left behind him a great name. Let those who are blameless cast the first stone at one who might have been better had he possessed those business facilities which make man respectable. He left us such a legacy of only genius, and genius not always, can leave." (Cheers.) Lord Coleridge returned thanks on behalf of the family. The assemblage then went to the Poet's Corner, and Mr. Lowell formally unveiled the bust, which bears the simple inscription, "Samuel Taylor Coleridge."

Special Papers.

THE ADJECTIVE IN LITERATURE.

[Read before the Grant County Teachers' Association.]

(Concluded from last issue.)

My next extract is from "Modern Painters," by Ruskin, where, in contrasting Turner and Claude, he describes sunset in tempest followed by serene midnight and sunrise. It is surpassingly beautiful, the most exquisite picture in English prose, and again I call attention to the adjective. "And then, as the sun sinks, you shall see the storm drift for an instant from off the hills, leaving their broad sides smoking, and loaded yet with snow-white, torn, steam-like rags of capricious vapor, now gone, now gathered again; while the smouldering sun, seeming not far away, but burning like a red-hot ball beside you, and as if you could reach it, plunges through the rushing wind and rolling cloud with headlong fall, as if it meant to rise no more, dyeing all the air about it with blood. Has Claude given this? And then you shall hear the fainting tempest die in the hollow of the night, and you shall see a green halo kindling on the summit of the eastern hills, brighter—brighter yet, till the large white circle of the slow moon is lifted up among the barred clouds, step by step, line by line; star after star she quenches with her kindling light, setting in their stead an army of pale, penetrable, fleecy wreaths in the heaven, to give light upon the earth, which move together, hand in hand, company by company, troop by troop, so measured in their unity of motion, that the whole heaven seems to roll with them, and the earth to reel under them. Ask Claude, or his brethren, for that. And then wait yet for one hour, until the east again becomes purple, and the heaving mountains, rolling against it in darkness, like waves of a wild sea, are drowned one by one in the glory of its burning; watch the white glaciers blaze in their winding paths about the mountains, like mighty serpents with scales of fire; watch the columnar peaks of solitary snow, kindling downwards, chasm by chasm, each in itself a new morning; their long avalanches cast down in keen streams brighter than the lightning, sending each his tribute of driven snow, like altar-smoke, up to the heaven; the rose-light of their silent domes flushing that heaven about them and above them, piercing with purer light through its purple lines of lifted cloud, casting a new glory on every wreath as it passes by, until the whole heaven—one scarlet canopy—is interwoven with a roof of waving flame, and tossing, vault beyond vault, as with the drifted wings of many companies of angels; and then, when you can look no more for gladness, and

when you are bowed down with fear and love of the Maker and Doer of this, tell me who has best delivered this His message unto men!" And so we might multiply instances; but enough I deem has been adduced to support the assertion made in the early part of my paper, that a simple adjective may be made to play a very important part in descriptive literary composition.

Then again there is humor as well as pathos in qualifying words; individual or national traits and follies and vices, together with the weaknesses and fallacies of philanthropists and closet enthusiasts being not infrequently crystallized in a few syllables. A chapter of Mark Twain is often compressed in an epithet; for instance, compare the following matter-of-fact statement: "He shows that the savage running wild in woods, eating horse, and sleeping in caves, had a great deal of human weakness in him," with: "He shows that the noble savage running wild in woods, eating raw horse, and sleeping in caves, had a great deal of civilized human weakness in him." What a world of irony is conveyed in that word "noble," what a scathing satire in the attribute "civilized!" The noble savage, as we are wont to term him till we know him. Noble, indeed! How noble? Hideously painted, following the war-path. More demon-like than man-like. Dancing his uncouth war dance, torturing his captives, glutting himself upon the blood of his foes, filthy in person, lazy when not at his favorite occupations, murder, rapine and revenge, and staggering, a pitiful, degraded object indeed, under the potent influence of the white man's fire-water—influence against which his nobility is not proof—an object for devils to deride and angels to weep over. Noble indeed! How inaccurate is history! What a liar is one's imagination! And the shaft aimed at civilized human weakness. How deserved! For human nature, whether savage or tame, is much alike; the cultured monarch in his *pare aux cerfs* encircled by courtiers, courtesans and sycophants is no more a hero, alas! than is the painted chief of the wilderness in his wigwam surrounded by his squaws and his vermin.

"The mild and intelligent Hindoo."

What an ironical epitaph for the people who have been stationary for ages, whose record, if anything, is retrograde, who perpetrated the massacre at Cawnpore, who butchered innocent women and mangled helpless infants. Standing by the monument, which now covers that dreaded well, within whose unhallowed precincts so many brave men fell, so many hapless beings found a premature grave, I have mused upon that word "mild," and only those who have done so, who have realized the tragedy in all its most awful detail may know the bitter irony which the satirist can convey into a simple English monosyllable.

But of all epithets that have ever been

coined by the ingenuity of man, to describe in a word or two the characteristics of a section of society that might well take a volume to record, I deem that the expression "the great unwashed" is entitled to first place. What exquisite humor is displayed in the association of those two words, both adjectives, the latter used as a noun! What a knowledge of human nature of a certain order! Why, it is a biography, nay, a complete library, containing within its cabalistic environment all that has ever been learned or said or written of that great class, whose representatives may be seen any day blacking boots on the steps of hotels, hanging round the slums and alleys, itinerantly proffering dubious-looking wares to equally dubious-looking customers, or cadging cents from the benevolent wayfarer.

A word upon oxymoron ere I conclude. By oxymoron is meant, as you are all doubtless aware, the conveyance of a thought by a contradiction of terms, as when Scott says in the *Lady of the Lake* :—

"Dark lightning flashed from Roderick's eye."

Now lightning is as a rule anything but dark—it is just the opposite, intensely light—but in this very juxtaposition of antonyms lies the beauty of the figure. There is perhaps no other combination of words of opposite meanings, which could so forcibly convey to the mind the look of intense scorn and anger flashed from the dark eye of the haughty and incensed Highland chieftain.

What an everlasting monument to the hypocrisy of man is the mere presence in his vocabulary of such a verbal compound as "pious fraud"! What a memorial to his frivolity is bequeathed to successive generations in Goldsmith's "idly busy"! What an attestation to human frailty and the stern necessity of restrictive law is syllabled in "cruel kindness"! What a homily to his insincerity in "religious cant"! What a touching tribute to his courage and patriotism in "forlorn hope"! Adjectives of adverse meaning attributes to reputable notions and *vice versa*, wresting each from each its significance, and in place of the pure tints from nature's palette leaving but the blurred and distorted outlines of a bungled copy limned by man's passions, his selfishness, or his greed.

But I have done. With you as students of language, I leave the subject, to expand if you will at your leisure. Well has Coleridge said, "Language is the armory of the human mind, and at once contains the trophies of its past, and the weapons of its future conquests." Those trophies, words of light and truth; those weapons still words, wielded by searchers after light and truth, and with patient, diligent, conscientious, loving search will come more light; more light and ever increasing truths

C. A. Morrison.

RIVERS.

RIVERS owe their origin, their direction, and their influence to the mountains. From the falling rains and melting snows of the mountain peaks are derived the supplies of water: down the side and along the valleys their courses are directed: and to the angle of declivity is due the swiftness or slowness of the currents thus arising. The rivers flow from the highest towards the lowest parts of the land, and in their descent they must follow the natural channels, rushing down the steep descent with powerful effect, curving in and out through the sinuous windings of the valleys, and lazily creeping along, slow and sluggish, through the level plains below. The history of the river-systems of North America, as of any other continent, will then be inseparable from the history of the mountain development. Let us consider these two together, and to do so we must retrace our steps and review the work and progress of many centuries. The river systems have been developed and are still changing, though in the main they adhere to a few definite laws of direction which we shall now consider.

The surface of the land owes its irregularities, hills and valleys, to foldings and upheavals of the crust. The upheavals are produced by internal action, the foldings by the settlement of the land itself and the downward pressure of the immense bodies of water on the surface. The peculiar outline of the continent is owing principally to this latter cause—the pressure of the oceans. The general outline of all continents is triangular, with the apex pointing southwards. In North America the base of the triangle butts against the pole and the apex joins on to South America. Thus the oceans whose pressure has wrinkled up this continent are the Pacific and the Atlantic, and, since the former is the larger, the western coast will be the longer, and the upheavals there—the mountains—will be more prominent than those on the east. The two forces may then be considered as being from the southwest and from the southeast. But this pressure has been gradually exerting its influence, and to trace its effect we must study the effects produced which can be clearly observed in the nature of the rocks. The history of the rocks thus gives us the history of the mountains, and from the latter we necessarily deduce the history of the rivers. The oldest rocks are Archaean, and they form the backbone of the American continent.

Commencing at the Thousand Islands we can trace them northeast and northwest, stretching to Labrador on the one extremity and away past the northern shores of Huron, Superior, and on through the northwest in the other direction, forming an irregular letter V, whose sides are parallel with the modern coast lines. These Archaean rocks,

the Laurentians, were our first formed watershed. To the southeast was the Atlantic, to the southwest the Pacific, and between, the basin of the modern Hudson Bay. Into these two oceans and this large bay the first rivers must have flowed, washing down the hard granite slopes in pure, unclouded streams.

But the pressure continued and the continent grew. The rocky shores were strewn with sand while the upheaval of land by the action of the ocean formed long rocky reefs parallel to the sides of the continent. These reefs of protruding rocks were the green mountains and the Alleghenies on the east, and the first ranges of the Rockies on the west. We have thus formed new watersheds and new river-systems. Labrador, Northern Quebec, Northern Ontario, some portions of the Eastern States, and a long strip of land through the western territories, were at this time above water, and the present river-systems outlined as follows:—To the north, between the V shaped Archaean rocks, was the Hudson Bay system; to the south, between the Archaean rocks and the Eastern States, was the St. Lawrence system; between the eastern and western mountain ranges was the Mississippi system; while on the extreme east and on the extreme west were the smaller systems of the two coasts. The Mississippi valley was then a broad sheet of water receiving streams from the east and west, shut out from the broad oceans by the mountain barriers gradually increasing in extent. Slowly this enclosed sheet of water filled up with sand and lime deposits, coal beds were formed, limestone strata laid down, salt beds deposited, and detritus washed down over and through it all. The Ohio and tributaries from the east and the Missouri and others from the west united their waters at the centre, and then turned south towards the present Gulf of Mexico. Raising of land to the south of Ontario separated the St. Lawrence and Mississippi systems, and ice and water scooped out the basins of the lakes. The upheaval of the land concluded its work, and all that was left to complete the course and nature of the systems was the influence of the rivers themselves. The influence and fuller development of the rivers that have thus been directed we will consider in our next article.

Charles James

CLEARNESS.

FLUENCY in the use of language is a necessary qualification of the teacher. The teacher should be an easy talker. Young pupils cannot endure *belaboring* with words on the part of the teacher. The attention of a pupil is of short duration. It cannot be held by one who

has to labor to work thoughts into words. Clearness of ideas contribute to fluency of speech. But a forcible talker must be clear. To deal with young undisciplined minds this important qualification is doubly needful. To speak clearly, we must think clearly. Thinking and speaking have a wonderful reflex action upon each other. Clear streams do not flow in muddy channels; and if you and I cannot use language to make a pupil see some point, may we not enquire whether the trouble is with us or the pupil, or it may be the point itself? We have heard some public men, who claim to be great men, say they "can't talk to children." If they cannot talk to children it is not because their great ideas cannot be compressed enough to enter juvenile minds, but because such minds will be interested in nothing but good and clear sense. The simplest forms of expression proceed from minds most learned. Involved sentences indicate the want of clear thought. The most prudent teacher must of necessity talk much, and he should be a *forcible* talker. A clear, forcible style must also be terse. Every word in a sentence is either a burden or a support. Every proposition should bear no needless weight. "Who is it that darkeneth counsel with words without knowledge?" He that does not think clearly, the careless teacher, the one who is not "exactly right" in anything. Again, redundancy is opposed to clearness. Addison says "Labor throws off redundancies." How often we are pained to hear a speaker make a most excellent point, and then, instead of stopping, continue to qualify the first or make another, until both are spoiled, like a painter, who, wanting just to touch some lineament of an already finished picture, drops his brush upon its face. Dr. Campbell's forcible illustration of the importance of clearness is at hand. He says, "If the medium through which we look at any object is perfectly transparent, our whole attention is fixed on the object: we are scarcely sensible that there is a medium which intervenes, and we can hardly be said to perceive it. But if there is any flaw in the medium, if we see through it but dimly, if the object is imperfectly represented, or if we know it to be misrepresented, our attention is immediately taken off the object to the medium." Much more is this true when applied to an object of thought. If not clearly presented, the attention of the pupil, the only means by which he is enabled to see the point, is directed to the teacher, the medium, instead of to the point, which the teacher is trying to present. Of course he does not see the point. He may be denounced as a stupid fellow, but this denunciation does not clear up the misty medium and he sees no better than before. Clearness, force and earnestness are the qualities which produce conviction in the minds of children, as well as in the minds of grown up people.—*Indianapolis Educational Weekly.*

Practical Art.

PERSPECTIVE.

TWELFTH PAPER.

REFERRING to problem 39, given in my ninth paper, it is seen that the cylinder required to be drawn is lying on the ground touching PP with its nearer, that is, its right hand end 3' 10" to the left of LD. First find the point *a* (fig. 22), the proper distance to the left, and measure from it to *b*, *G'*, the length of the cylinder. Now on a perpendicular at *b*, or at a point to the left of it, as *c*, make *cc* equal in length to the radius of the cylinder, and with *e* as a centre and *cc* as radius, draw a semi-circle, enclose it in a half square, and proceed as usual to find the points *1* and *2*. From *d*, *r*, *e* and *z*, draw horizontal lines to cut perpendiculars from *a* and *b* in *h*, *p*, *r*, *m*, *s*, *t*, etc., and from these points draw lines towards CV.

As the cylinder is *S'* in diameter, measure that distance to the left of *b*, and draw *s* LMP to find *k*. The squares *hkkb* and *mona* can then be completed, and their diagonals and vertical diameters drawn, when the remaining points corresponding to *1* and *2* will be obtained. Draw the elliptical curves and join their extremities by horizontal lines. The principle involved in this problem is the same as that explained in problem 27, fig. 16, eighth paper.

If the cylinder were lying on the ground with its ends parallel to PP, it would be necessary to find the perspective position of the centre of each end and with the perspective length of the radius in each case, draw a circle and join the extremities.

Problem 40.—Height, 6'; distance, 16'; scale, 1/48. A hexagonal prism, 4' long,

edges of ends, 3', stands on end with the extreme left hand corner of base 3' to the right, and the front face 2' back. Centrally upon it is placed a cube of 3' edge, and the top of this cube is the base of a pyramid 3' high. Show the group. Fig. 23.

First find the point *a*, 3' to the right, then

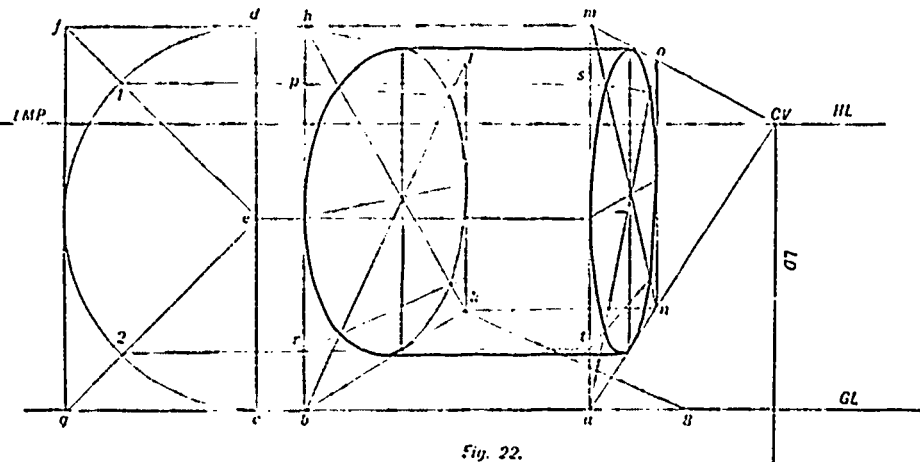

Fig. 22.

b, 2' distant from *a*. Through *b*, draw a horizontal line, making *bc* 1' 6" long, and *cd* 3' long. Upon *cd* construct an equilateral triangle—*e* will be the centre of the hex-

Measure on perpendiculars from *l* and *m* the length or height of the prism—4', to *o* and *p*, and from these points draw lines towards CV to cut perpendiculars from *z*, *3* and *4*; horizontal lines from these new points to cut perpendiculars from *1*, *6* and *5* will find the remaining corners of the top.

Now, because the cube is placed centrally upon the prism, its centre will be over *l*. Through *l*, then, draw a line towards RMP, to cut *1 5* in *δ*, and *2 4*, in *γ*; *γ* and *δ* would be two corners of base of cube if it were resting on the ground, because the edges of the cube are equal in length to the edges of the ends of the prism—3'; complete the square and from its corners erect perpendiculars to meet lines corresponding to *1 5* and *2 4*, on the top of the prism. The height of the cube will be measured from *r* on the perpendicular at *m*, and the height of the pyramid on the perpendicular at *n*.

Problem 41.—Height, 7'; distance, 15'; scale, 1/24. Place in perspective a hexagonal prism 8' long; edges of ends, 3'—lying on the ground with its ends parallel with PP. The near end is 3' back, its centre being 4' to the right.

A. J. READING.

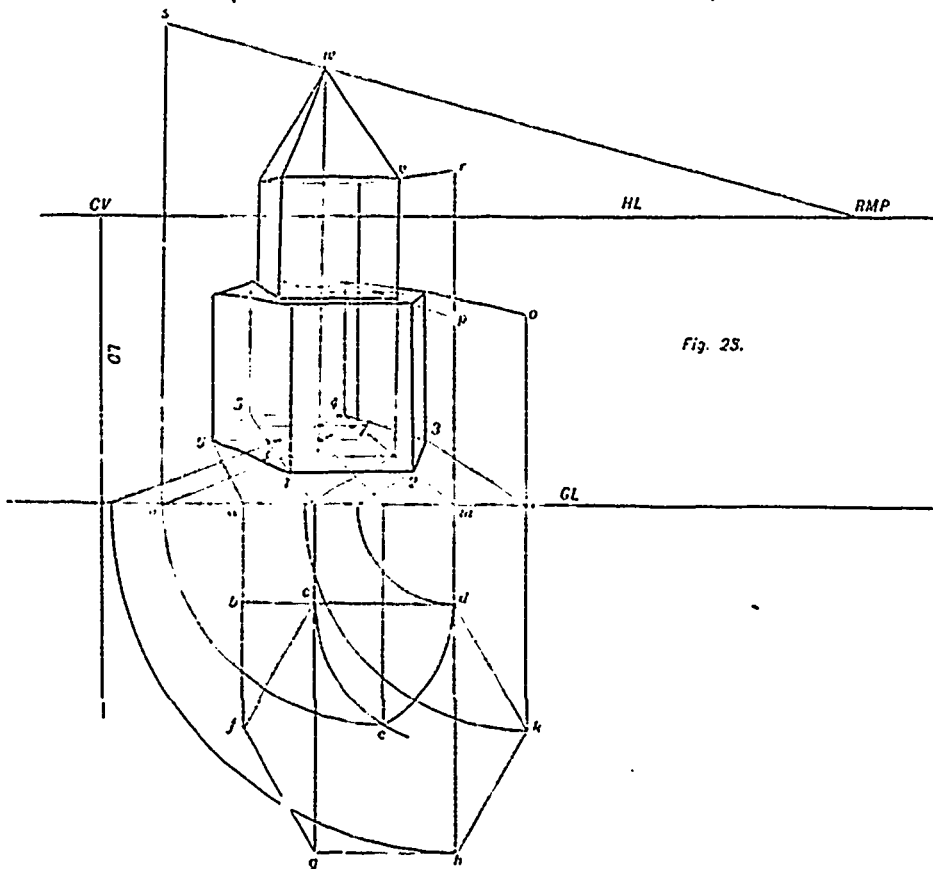

Fig. 25.

agonal base. Complete the plan of the base, and draw lines from the points *f*, *c*, *e*, *d*, *k*, vertically upwards to cut the GL, and draw lines from these new points towards CV. The base of the prism can now be drawn.

grades rise, to fifteen hundred or two thousand dollars a year. Though the schools are usually kept in old convents or church buildings the education is not such as can be called ecclesiastic.

PROFESSOR THOMAS CUSHING, of Boston, finds, after as careful inquiry as he could make while visiting the country, that public education in Mexico is in a hopeful condition. He gives the results of his observations in *The Journal of Education*. Compulsory education prevails in the City of Mexico. Fair salaries are paid, the lowest being \$50 a month in the primary grades, and increasing as the

The Public School.

LEARNING TO READ.

BY DR. H. RULISON, SUPT. SCHOOLS, WATSEKA, ILL.

THE FIRST LESSON.

WE place before the child a simple picture. A man; a table by his side; a hat on the table; a mat on the floor; a cat on the mat. This is our picture to suggest ideas. The prominent object is the man. We ask, "What is it?" The child answers, "It is a man." We place the picture out of sight and write on the board, "It is a man." The writing itself attracts attention. There is nothing on the board but this one sentence. The child has said, "It is a man;" we write, "It is a man." The child has now to learn to associate his spoken words with our written words. We point to the written words in succession and say, "It is a man." As we point the child says, "It is a man." This is repeated many times. The association is soon established. The words "it" "is" "a" "man," are learned so well that the child can pronounce them in whatever order they may be pointed out. Thus ends the first lesson.

THE SECOND LESSON.

We place before the child the same picture as before. Pointing to the mat we ask, "What is it?" Answer, "It is a mat." We write on the board two sentences: "It is a man," and just below it, "It is a mat," in this way:

It is a man.
It is a mat.

The child reads the first sentence first. He then begins to read the last sentence. He reads until he comes to the word "mat." At this word he hesitates and stops, for "mat" looks different from "man." We tell him it is "mat." He then reads both sentences without further trouble. We call his attention to the words "man" and "mat." How do they differ? One ends with "n" the other with "t." The child sees dimly that the words are made up of parts. Thus ends the second lesson.

THE THIRD LESSON.

We place before the child the same picture again. Pointing to the cat we ask, "What is it?" Answer, "It is a cat." We write:

It is a man.
It is a mat.
It is a cat.

The child reads without difficulty till he comes to "cat." We tell him it is "cat," when he reads the three sentences with ease. We call his attention to the words "mat" and "cat." How do they differ? One word begins with "m," the other with "c." The child sees less dimly that words are made up of parts. Thus ends the third lesson.

THE FOURTH LESSON.

We use the same picture again. Pointing to the hat we ask, "What is it?" Answer, "It is a hat." We write:

It is a man.
It is a mat.
It is a cat.
It is a hat.

The child reads easily until he comes to "hat." We tell him it is "hat." He can now read four sentences. He sees the "h" in "hat" differs from the "c" in "cat." He may now learn the letters m, n, t, c, h, a. Thus ends the fourth lesson.

What has the child learned in these first four lessons? He has learned to read four sentences. He will never forget the idiom "it is." Whenever and wherever he sees these two words he will never hesitate to pronounce them. The word "man" is as thoroughly learned; the word "mat" less thoroughly; the word "cat" still less so; and the word "hat" least of all. The child sees dimly that the words are made up of letters, and he knows a few of them. The idiom "it is" means nothing to him, though it stands for spoken words. But the words "man," "mat," "cat," and "hat," represent ideas, and the stimulus in these lessons is the idea—the method is practically the word method.—From the "Educational News."

LANGUAGE LESSON.

1. Fill the blanks with the proper form of *Louis, Mr. Ross, fly, week, and sparrow.*
 — mother has no one else to send.
 — horse was frightened by the music.
 • All — wings are transparent.
 At the close of ten — work vacation begins.
 The boys had found some — nests near the ball ground.
2. Fill the blanks with the proper form of *water, waves, and princess.*
 The boat was drawn to the — edge.
 You noisy — roll higher up the strand.
 "We do not dare," the — reply.
 What was the — reply?
 She was dressed like an Indian — .
 The — dress was of deer-skin.
3. Which of the sentences above is a command? Which is a question? Which contains a quotation?
4. Fill the blanks with some form of *do, go, come, and choose.*
 He — his work and — to school early.
 If he had — to play, he could not have — so soon.
 Has the teacher — ?
 Have you — a good subject for your composition?

The above exercise was given as a written examination to test the pupils in their knowledge of language as far as they had been taught. On reading their papers it was found that many had failed to use their common sense, and some did not know the proper forms of the words. Such sentences as follow were found on several papers: "Mr. horse was frightened by the music." "The

Indian dress was of deer-skin." Remember the word "Indian" is not one of those from which they were to choose. "All sparrows wings are transparent." By questioning afterward it was found that only one pupil in the class knew what *transparent* means. Common sense would have said, "Don't use a word that means nothing to you."

But some one says, "You cannot expect children of this grade to have as much judgment as you suggest." Proper teaching will give them this power to judge. This examination surprised the teacher, and the papers were handed to the children and a lesson, substantially as follows, was given:

Tr. In the first sentence, whose mother is meant?

Pu. Louis's mother, (orally).

Tr. Why not Mr. Ross's mother?

Pu. Because Mr. Ross is a man, and his mother would not send him on an errand.

Tr. Spell the form of Louis that you read.

Pu. Louis's.

Tr. What does it mean?

Pu. It means one and shows ownership.

Tr. Who most likely owned the horse, the boy or the man?

Pu. The man.

Tr. Mary, what will you put in the next sentence?

Mary. Mr. Ross's.

Tr. Spell it, Mary. Mr period, capital R—o—double s, apostrophe—s.

Tr. Why not put Mr. alone?

Pu. Because it don't make no sense.

Tr. Because it *doesn't* make any sense.

What does transparent mean?

Pupils looked blank. Finally one little fellow in the back part of the room put up his hand rather hesitatingly, and the teacher said, "Well, Tommie?"

Tommie. What you can see through.

Tr. Tommie is right. Anything that we can see through is transparent. Name something that is transparent.

Pupils (looking at the windows). Tr. Class. Pu. Glass.

Tr. How many of you have looked at a sparrow's wing? at a fly's wing? (nearly all had). Which one can you see through? Class.

Pupils. The fly's wings.

Tr. Which of the words must we take to fill the blank? class.

Class. Fly.

Tr. What must the form that we use mean? Susie.

Susie. It must mean more than one.

Tr. How do you know?

Susie. Because the word *all* means more than one fly.

Tr. What else must it mean?

Pu. It must mean ownership.

Tr. Write on the board the form that means more than one.

Pu. Flies.

Tr. What must we do to make it show ownership?

Pu. We must add an apostrophe.

Tr. Yes. Add it.

This is slow work but it is good work. The pupil has been led to think about the things that he *must* think about to properly fill the blanks given. This kind of work will teach him to use his common sense.

The third sentence is faulty because it contains a word that was not in their vocabulary. They should not have undertaken to fill the blank at all. It was a mere *guess* on their part.

There is material enough in this set of questions for another lesson of this sort, but not half enough in the whole set for one *guess* lesson.—From "The Indiana School Journal."

The High School.

QUESTIONS ON THE LADY OF THE LAKE.

1. Each Canto is introduced by one or more stanzas in the Spenserian metre. Explain what you mean by Spenserian metre
2. "Byron employed the same metre in his greatest poem." Name the poem.
3. In which of Scott's poems is the plot most regular and interesting?
4. There is a wealth of beautiful description in the first Canto of The Lady of The Lake. Quote stanzas to illustrate the variety of this description.
5. What do you consider the chief feature in Scott's poetry?
6. Carlyle charges Scott with selfishness in his literary career. Have you anything to offer in rebuttal of this charge?
7. Name the two figures of speech most frequently used by Scott in The Lady of The Lake with the particular purpose which they serve.
8. A writer says that Marmion has greater faults and greater beauties than The Lay of the Last Minstrel. Point out these faults and beauties.
9. In which of Scott's works did his genius reach its highest point?
10. "Glory pure and unsullied was the ruling aim and motive of Milton; honor and integrity formed the incentives to Scott." Explain the motives attributed by the writer to Scott.
11. What does Mr. Ruskin say about the great prominence Scott gives to color in his poetic portraits of nature?
12. What have you to say about the diction of Scott's poetry?
13. Contrast with Scott, Byron, Campbell and Wordsworth as poets.
14. Give the names of Scott's characters in The Lady of The Lake.
15. Quote the stanzas which form pen pictures of "The Knight of Snowdon" and "The Lady of The Lake."

16. Name the songs that are found in The Lady of The Lake with the circumstances of their introduction.

17. In which of Scott's works do you find the following lyrics: "The Coronach," "Pibroch of Donnail Dhu," and "The Hymn of the Hebrew Maid"?

18. A glow of national feeling, martial ardor, and a love for the pomp and circumstance of war permeate Scott's poems. Illustrate each of these elements by quotations.

19. Do you find much of the magic use of words—the *curiosa felicitas* of expression in Scott's poetry?

20. Scott is fond at times of introducing a moral in his poems. Give examples of this.

21. In which of his battle scenes does Scott reach the highest point of patriotic feeling?

22. How do you account for the fact that Marmion is so largely charged with the very atmosphere of pomp and circumstance of war?

23. We read in The Lay of the Last Minstrel the following lines:—

"Call it not vain; they do not err
Who say that when the poet dies,
Mute nature mourns her worshipper,
And celebrates his obsequies;
Who say tall cliff and cavern lone,
For the departed bard make moan:
That mountains weep in crystal rill;
That flowers in tears of balm distil;
Through his loved groves that breezes sigh,
And oaks, in deeper groans reply;
And rivers teach their rushing wave
To murmur dirges round his grave"

Apply this quotation to the tear-stained neon-tide that rested upon Abbotsford on the 21st September, 1832.

John D. Hagan

Educational Intelligence.

THE CONTENTS OF CHILDREN'S MINDS.

SOME light may be thrown on the question which is being discussed with so much warmth in the press, as to the value of the methods employed in the recent inquiry into the existence of over-pressure in elementary schools, by a study of some interesting inquiries made into the contents of the minds of children of the same class in Germany and America. The object of the inquiries was to ascertain the nature of the material, in its rough state, on which schoolmasters in elementary schools in towns like Berlin and Boston had to work before the Government inspector appeared on the scene. The inquiries were instituted by the Pedagogical Society of Berlin and by Mr. Stanley Hall, of Boston, and although the tests employed were of a very simple kind they were found to be of very difficult application, as neither the

society nor Mr. Hall were willing to accept the results of a mere show of hands in answer to questions satisfactory. The chief problem to be solved was, "What may city children be assumed to know and have seen by their teachers when they enter school?" In the case of Berlin the results were far from being satisfactory, and out of about 2,000 returns sent in only about half of them gave trustworthy results. With the experience of the German society before him, Mr. Stanley Hall undertook an examination of a similar kind in the elementary schools of Boston, and framing a new set of questions more in accordance with the surroundings of American children, he employed four of the best trained and experienced kindergarten teachers to carry out the examinations by questioning three children at a time. On account of the strictness of the conditions, Mr. Hall was only able to accept the records of about two hundred examinations, and these he has tabulated according to the percentage of ignorance of the whole number of children, and also comparatively as to that of boys, girls, Irish children, American children, and children under training in the kindergarten. The results as shown by these tables will, we think, be a great surprise to most people, and we regret that we can only give a few examples, choosing those which show the amount of ignorance on subjects which should be best known to children, and not those which show the highest percentage of ignorance. The ages of the children ranged from four to eight years, and they were chiefly of Irish and American parentage, a small number being German. The returns were carefully tabulated to determine the influence of age, "which seemed surprisingly unpronounced, indicating a slight value of age *per se* as an index of ripeness for school." Of familiar living objects, 65.5 per cent of the children had never seen an ant, 63 per cent a snail, and 20.5 per cent a butterfly. Of trees, vegetables, and flowers, 83 per cent did not know the maple tree, 63 per cent had never planted a seed, 61 per cent had not seen potatoes grow, 55.5 had never gathered buttercups, and 54 per cent had not seen roses growing. Of the parts of their own bodies 90.5 per cent did not know where their ribs were, and 21.5 per cent did not know their right hand from their left; 75.5 per cent did not know the seasons of the year, and 65 per cent had never seen a rainbow. With regard to home surroundings 93.4 per cent did not know that leather things came from animals, 89 per cent did not know what flour was made of, 88 per cent were unable to knit, 64.5 per cent had never bathed, 36 per cent had never saved cents at home, and 35.5 per cent had never been in the country. With respect to the sexes, boys appear to be more intelligent than girls on all subjects except

the parts of the body. The American children were more intelligent than the Irish, and, as might be expected from the nature of the questions, those trained in the kindergarten were far ahead of both. Although the tables do not show it, Mr. Hall asserts that country-bred children rank higher than city children in all the subjects of examination, and in many items very much higher.

Besides the tabular results Mr. Hall gives examples of many curious answers which were elicited during the examinations, and which show the ease with which a child's imagination is led astray, often by the mere jingle of rhyme, alliteration, and cadence of words and sentences. Thus, butterflies make butter or eat it, grasshoppers give grass, bees give beads and beans, all honey is from the honeysuckles, kittens grow on the pussy-willow, and even poplin dresses are made of poplar-trees. When a cow lows it blows its own horn; at night the sun goes or rolls or flies, is blown or walks, or God pulls it up higher out of sight. He takes it into heaven and perhaps puts it to bed, and even takes off its clothes and puts them on in the morning. The moon comes around when it is a bright night and people want to walk, or forget to light some lamps. Thunder is God groaning, or kicking, or turning a big handle, or grinding snow; walking loud, breaking something, throwing logs, having coals run in, pounding about with a big hammer, hitting the clouds, clouds bumping or clapping together or bursting, are samples of a number of curious answers which show that inquiring into the contents of children's minds must be an exceedingly entertaining, if not a very profitable occupation. It would seem that the idea of Paradise is not the same with children as with their parents in America. Everything that is good and imperfectly known to children is located in the country, and when good children die they do not go to Paradise but to the country—"even here from Boston," adds Mr. Hall. The lessons for parents, schoolmasters, and examiners which are to be learned from these interesting inquiries are, according to Mr. Hall, that the knowledge which an average child of the laboring classes in towns possesses at the outset of school life "is next to nothing of pedagogic value," and the best preparation parents can give their children for good school training is to make them acquainted with natural objects, especially with the sights and sounds of the country, and talk about them; and to send them to good healthy kindergartens. The table showing the percentage of ignorance indicates the order in which education should be affected; the conditions which immediately surround a child are most easily learned, and those which are more remote with greater difficulty, hence the advantage of objects and the dif-

ficulty and dangers of books and word-cram. School inspectors and psychologists may also learn from Mr. Hall's experiment how much tact and ingenuity is required to arrive at the contents of children's minds, and how careful they should be of accepting the results of questioning large bodies of them. The astounding ignorance displayed by the poor children of Berlin and Boston, and which no doubt is equalled, if not surpassed, by the same class in our own country, is but the reflex of the ignorance of their parents and the population among whom they are bred, and any cry like that of over-pressure which is likely to interfere with the slight efforts being made to remove it, should be well weighed and accepted only on the clearest scientific proof—a kind of proof which is not attainable from the data we now possess.—*From the Pall Mall Gazette.*

THE McCormick Observatory of the University of Virginia was dedicated on April 13, the anniversary of the birth of Thomas Jefferson. The building is surrounded by a dome forty-five feet in diameter and weighing 25,000 pounds. The telescope is a duplicate of that in the Naval Observatory, its focal length being thirty-two and one half feet, and the clear aperture of the object glass twenty-six inches. It cost \$46,000, and the building about \$30,000: both the gift of Leander J. McCormick of Chicago. The directorship of the observatory is endowed with the sum of \$50,000, of which \$22,000 was given by Virginia, and the rest by citizens of New York, Philadelphia, Boston, and Baltimore. An additional sum of \$25,000 was also given by W. H. Vanderbilt, of New York. Prof. Ormond Stone, the director in charge, is a graduate of the Chicago University.

AN announcement of much interest has recently been made in England by Mr. Henry J. Wharton, who is about to publish a small volume, printed with fastidious care, containing the poems and a memoir of the Greek lyric poet, Sappho. Mr. J. Addington Symonds assists him in the preparation of the work, and it will contain an ideal portrait of Sappho after Alma Tadema. The book is to consist of two parts—the first part giving a popular account of all that is known of Sappho's history, and the second containing the original text of every fragment of her writing that has come down to us, together with a literal prose translation, and all the better renderings into English verse that have been made of them. The editor adds:

My aim has been to set before English readers every fact and legend of Sappho's life, and every proof of her genius, that is within the reach of modern scholarship; to make, indeed, unfamiliarity with Æolic Greek no longer a bar to understanding the grounds on which she (Sappho) has been held so supreme an artist for two thousand years. No similarly exhaustive attempt has ever been made in any language.

The volume will be foolscap 8vo in size. Twenty-five copies, with proofs of the portrait, will be made on large paper. Ten of the large paper copies, with two hundred and fifty of the small paper, from the American edition, will be issued by Jansen, McClurg & Co., of Chicago.

The price in England will be 7s. 6d. for the small paper, and one guinea for the large; there will be only fifteen of the latter for all England, and these are understood to be already subscribed for. The price in America has not yet been announced, although the volume is nearly ready.

LEOPOLD VON RANKE is considered in Europe, says the *N. Y. World*, "the most astonishing author of his time, in respect of the preservation of his mental powers. There is not another living example of a man occupied with historical work in his ninetieth year. He believes he will be able to continue his studies and writing till he has reached a hundred."

HENRY M. STANLEY—the most eminent of all travellers in Africa—"is described," says the *Boston Beacon*, "as short, broad-shouldered, strong, though not fleshy, and as having very keen eyes as well as a very energetic expression about his mouth and chin. The Berlin Conference treated him deferentially. He was born in 1840, but looks as if he was over fifty years old."

Correspondence.

ARBOR DAY IN OTONABEE.

To the Editor of the EDUCATIONAL WEEKLY.

SIR,—The ratepayers of Union S. S. No. 6 and 2, Oton and Asphodel, gave practical expression of their appreciation of the æsthetic by a fair representation of them responding to the proclamation issued by the Minister of Education for the observance of Ontario's first Arbor Day. More than fifty trees of various kinds were planted in the afternoon in presence of teacher and pupils, who also assisted in decorating the school grounds that occupy the elevated position of being "set on an hill," commanding a fine bird's-eye prospect of parts of four or five townships. On the following Monday the teacher and pupils, with much enjoyment, proceeded to appropriate trees to their respective owners, receiving the appellation of some renowned warrior, statesman, poet, writer, etc., not forgetting to assign a most honorable place to the Hon. G. W. Ross, author of our gala Arbor Holiday. To inculcate a spirit of good will and peace to men, even in politics, Sir John A. Macdonald and Mr. Mowat stand, or rather grow, lovingly side by side. Some regard was also observed in the analogy of tree and honorary title; for instance, a small and puny sapling was named after Pope, while a fine, healthy looking maple received the honor of Gordon's name and fame, and a silver poplar that of Washington's, etc. The celebration of Arbor Day will be beneficial in many ways: already the pupils manifest a lively interest in their trees and display pardonable pride in the ownership of a Wolfe or Brock, good-naturedly claiming their merits *par excellence*. A part of Friday afternoon is to be devoted to the subject of Forestry, and two pupils are expected to furnish something bearing on the kind of tree under their proprietorship, as well as readings or recitations in relation to the one for whom it is named.

ELIZABETH BECKET.

Otonabee, May 18, 1885.

Examination Papers.

ADMISSION TO HIGH SCHOOLS.

[We intend for the future to insert under this heading, in chronological order, the various examination papers that have been set for admission to high schools.]

GRAMMAR.

DECEMBER, 1879.

1. Define: Comparative Degree, Conjunction, Gender, Participle, Relative Pronoun and Subjunctive mood.

2. Parse: "The Spaniards employed coast-guards to keep off interlopers, the commanders of which were instructed to massacre all their prisoners."

3. Analyse: "After the banquet, a shower of scented water, scattered from invisible pipes, spread perfume over the apartment."

4. Correct the following, and give reasons for making the changes necessary:

(a) I am not sure but what it is right.

(b) I will not go, except you promise to come too.

(c) He is more cleverer than any one I ever seen.

5. Give the past participle of go, have, lay (to place), and drink; the feminine of earl, stag, and miser; the plural of medium, madame, wharf, and scarf; and the possessive plural of mechanic and and lady.

6. (a) Give six rules for the use of capital letters.

(b) Inflect "which."

(c) Inflect "to see," in the future past indicative.

JUNE, 1880.

1. Parse: "The stranger trod upon alabaster slabs, each bearing an inscription recording the titles, genealogy, and achievements of the great king."

2. Analyse: "He who entered them might thus read the history, and learn the glory and triumphs of the nation."

3. (a) Define four classes of Pronouns, and give an example of each class.

(b) Decline "he" in both numbers.

4. Correct the following, if necessary, giving your reasons for making the changes:

(a) It could not have been her.

(b) You are stronger than me.

(c) I cannot walk like you.

(d) My friends approve my decision, especially them who are best acquainted with the circumstances.

(e) I do not know neither how it was done nor who done it.

5. (a) What nouns form their plural by adding *es* to the singular.

(b) Write the possessive plural of lady, orphan, mechanic.

6. Write the third singular form of "to see" in each tense in the indicative mood.

DECEMBER, 1880.

1. Parse: "The Europeans were hardly less amazed at the scene which presented itself to their view."

2. Analyse:

"Beneath, in the churchyard, lay the dead, In their night encampment on the hill."

3. Write the plural and the possessive singular of John, James, and King of England; and the third singular present indicative active of deny, crow, dye, cross, box, shock.

4. Define Comparative Degree, Relative Pronoun, Adverb, and Participle.

5. Correct what is wrong in the following sentences, giving your reason in each case:

I find them in the garden,
For there's many hereabout.

Let every child bring their books to-morrow.
All persons writing or defacing the wall will be expelled.

Why are you sorry for him?

Have either of you a pencil?

He said it was to be given to either you or I.

You or I are to go.

JULY, 1881.

1. Parse: "The region destined to form such an important part of our empire, and attract universal notice, had not been previously visited by any Englishman."

2. Analyse: "Some time after this occurrence, one of the nobles of the court, a proud, ambitious man, resolved to destroy the king and place himself on the throne."

3. Write the past tense and the past participle of strive, win, set, loose, fetch; the present indicative second person singular of do, espy, quit; the plural possessive of woman, miss, bandit.

4. What is meant by Conjunction, Transitive Verb, Neuter Gender, Common Noun?

5. Write a list of nouns having the same form for both singular and plural.

6. Correct any mistakes in these sentences, and give the reasons for your corrections:

(a) I expect it was her as done it.

(b) After they had went a little ways, they returned back home again.

(c) I believe that's them

(d) Between you and me he is not as wise as he seems.

(e) The teacher says we will be fined if we do not attend more regular.

DECEMBER, 1881.

1. Analyse: Vainly did I then wait for the tardy and rebellious villains to come to my assistance, making the welkin ring, and my throat tingle, with reiterated shouts.

2. Parse: Notwithstanding our enemies' protests, and the fears of a good many others, a ten years' peace was, after some time, agreed upon.

3. Some words ending in *ing* are adjectives; others participles, others nouns, others prepositions. Write four sentences, each containing a word in *ing* to show this.

4. Write the past indicative third singular of cast, lay, fetch, set; and the past participle of flow, lead, come, sit, die, swim.

5. In what different ways is the superlative degree of adjectives formed? Give examples, and

state why some adjectives do not admit of a superlative degree.

6. What is the use of the Relative Pronoun?

7. Correct errors in the following sentences, giving your reasons:

(a) "There's some people as never shuts the stable door until the horse is stole."

(b) Will we have a holiday after this examination I wonder.

(c) She is as old as I but I am taller than she.

(d) Every person must bear their own burden.

JUNE, 1882.

1. What are the two principal parts of a sentence? Give examples of the different kinds of sentences.

2. Enumerate, with examples, the different ways in which the Predicate may be enlarged.

3. Define a Transitive Verb. Exemplify the active and passive construction of Transitive Verbs.

4. Write down the past tense and the past participle of the following verbs: think, teach, sling, spring, rive, saw, mow, lade, burst.

5. Inflect "may" and "can" in the past tense. Give the exact meaning of each.

6. How do nouns ending in *f* or *fe*, preceded by a long vowel, usually form the plural? Give some exceptions. Write down the plurals of church, child, dwarf, hoof, stuff, brief, grotto, cargo, leaf, ally.

7. Analyse the first of the following sentences, and parse the words in italics:

(1) The troubles of mankind *are often aggravated by imaginary evils.*

(2) *He that fights and runs away Lives to fight another day.*

(3) *At the end of the long valley he passes the dens in which the old giants dwell, amidst the bones of those whom they had slain.*

8. Correct any mistakes in the following sentences, and give reasons for your corrections:

(1) I will ask my teacher if I can leave at 3 o'clock.

(2) Every boy in the class must do their own question.

(3) The best scholar whom I have yet examined has only made fifty per cent.

(4) Some day this earth will be old, and requires the purifying power of fire.

(5) My trusty counsellor and friend has warn-ed me to have no dealings with such a man.

THE title-page of the most recent issue in the series of "Simplified Grammars" has a typically cosmopolitan look; it reads thus: "A Compendious Sanskrit Grammar, with a brief sketch of Scenic Prakrit. By Hjalmar Edgren, Ph.D., Professor of Sanskrit in the University of Nebraska, U.S.A., formerly Lecturer on Sanskrit in the University of Lund, Sweden. London: Trübner & Co." That is, the exposition of a language of ancient India by a Swedish professor in Nebraska is published by a famous German firm in London. The little book is designed for the use of beginners before they proceed to the full and elaborate grammar of Whitney, whose authority and system Edgren—himself a pupil of Whitney—has naturally followed.

"SURPASSES ALL ITS PREDECESSORS."—N. Y. TRIBUNE, March 13, 1885.

STORMONTH'S ENGLISH DICTIONARY

A Dictionary of the English Language, Pronouncing, Etymological and Explanatory, embracing Scientific and other Terms, Numerous Familiar Terms, and a Copious Selection of Old English Words. By the REV. JAMES STORMONTH. The Pronunciation Carefully Revised by the REV. P. H. PHELPS, M.A.

IN ONE IMPERIAL OCTAVO VOLUME OF 1248 PAGES.

SOME PRESS NOTICES.

"A work which is certainly without a rival, all things considered, among dictionaries of our language. The peculiarity of the work is that it is equally well adapted to the uses of the man of business, who demands compactness and ease of reference, and to those of the most exigent scholar."—N. Y. COMMERCIAL ADVERTISER.

"A well-planned and carefully executed work, which has decided merits of its own, and for which there is a place not filled by any of its rivals."—N. Y. SUN.

"A question as to the safest and most convenient dictionary of our language may be safely answered in favor of Stormonth's very admirable and peerless work."—THE BEACON, Boston.

"If an office, school-room, or family can have but one dictionary, Stormonth's is the best."—BOSTON ADVERTISER.

"As compared with our standard dictionaries, it is better in type, richer in its vocabulary, and happier in arrangement. Its system of grouping is admirable."—CHRISTIAN ADVOCATE, N. Y.

"A critical and accurate dictionary, the embodiment of good scholarship and the result of modern researches. . . . It holds an unrivalled place in bringing forth the result of modern philological criticism."—BOSTON JOURNAL.

"It has the bones and sinews of the grand dictionary of the future."—ECCLESIASTICAL GAZETTE, London.

"The work will be a most valuable addition to the library of the scholar and of the general reader. It can have for the present no possible rival."—BOSTON POST.

"Stormonth's Dictionary, in the new and enlarged form, is, in our opinion, the nearest approach to the ideal popular dictionary that has yet appeared in our language."—N. Y. MAIL AND EXPRESS.

By special arrangement with Messrs. Harper & Brothers, the American publishers, we are able to offer the STORMONTH DICTIONARY at the following EXCEEDINGLY LOW RATES:

CLOTH, - -	\$5 00,	with ONE YEAR of "THE EDUCATIONAL WEEKLY" FREE.
HALF ROAN,	7 00,	" " " " " "
FULL SHEEP,	7 50,	" " " " " "

We would especially recommend the Half Roan or Full Sheep Bindings.

PRESENT SUBSCRIBERS MAY SECURE A DICTIONARY BY PAYING THE DIFFERENCE BETWEEN THE ABOVE PRICES AND THE AMOUNTS ALREADY PAID.

THERE SHOULD BE A COPY OF STORMONTH'S DICTIONARY IN EVERY SCHOOL IN THE COUNTRY.

Address— EDUCATIONAL WEEKLY,

GRIP PRINTING AND PUBLISHING CO., TORONTO.

THE NINTH NUMBER OF
 THE CANADIAN PICTORIAL
 &
ILLUSTRATED WAR NEWS

WILL BE ISSUED ON

SATURDAY, MAY 30th,

AND WILL CONTAIN

THE FOLLOWING ILLUSTRATIONS:

IN THE SKIRMISH LINE AT BATOUCHE.

(From a Sketch by Mr. E. W. Morrison.)

THE 65TH BATTALION (MOUNT ROYAL RIFLES) AT PORT ARTHUR.

(From a Photograph by Cooke.)

LIEUT.-COL. GRAY, M.P.P., COMMANDING THE TORONTO FIELD BATTERY.

(From a Photograph by Hunter & Co.)

A ZAREBA IN THE NORTH-WEST.

(From Diagram and Description by the "Globe's" Correspondent.)

THE ARTILLERY SHELLING THE ENEMY AT THE BATTLE OF FISH CREEK.

THE APPLICATION OF THE FIRST BANDAGE ON THE BATTLEFIELD—No. 1.

(From Original Sketches by Mr. J. Humme.)

Also the usual fine *two-page supplement* entitled "THE BAYONET CHARGE AT BATOUCHE."

PRICE, 15 CENTS PER COPY.

SPECIAL OFFER.—As many persons have requested the publishers to mail them papers weekly as issued, they have decided to make the following offer: The paper will be supplied for Eight consecutive issues to all persons sending \$1.00, or two persons can club together and each receive a copy for four consecutive issues for this amount.

N.B.—Back numbers can still be had from the publishers.

THE GRIP PRINTING & PUBLISHING CO.,

TORONTO!

THE TRADE SUPPLIED BY THE TORONTO NEWS CO.

Addressed to W. H. E. Feb 19 88
 Toronto