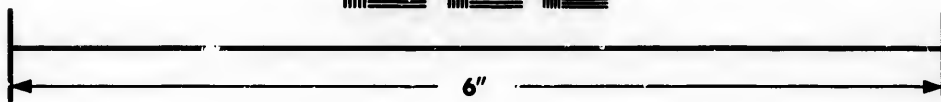
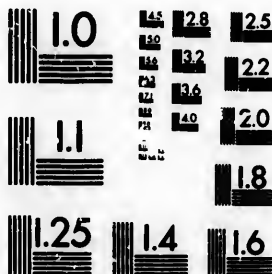

**IMAGE EVALUATION
TEST TARGET (MT-3)**



**Photographic
Sciences
Corporation**

23 WEST MAIN STREET
WEBSTER, N.Y. 14580
(716) 872-4503

18
20
22
25

**CIHM/ICMH
Microfiche
Series.**

**CIHM/ICMH
Collection de
microfiches.**



Canadian Institute for Historical Microreproductions / Institut canadien de microreproductions historiques

10

© 1983

Technical and Bibliographic Notes/Notes techniques et bibliographiques

The Institute has attempted to obtain the best original copy available for filming. Features of this copy which may be bibliographically unique, which may alter any of the images in the reproduction, or which may significantly change the usual method of filming, are checked below.

L'Institut a microfilmé le meilleur exemplaire qu'il lui a été possible de se procurer. Les détails de cet exemplaire qui sont peut-être uniques du point de vue bibliographique, qui peuvent modifier une image reproduite, ou qui peuvent exiger une modification dans la méthode normale de filmage sont indiqués ci-dessous.

- Coloured covers/
Couverture de couleur
- Covers damaged/
Couverture endommagée
- Covers restored and/or laminated/
Couverture restaurée et/ou pelliculée
- Cover title missing/
Le titre de couverture manque
- Coloured maps/
Cartes géographiques en couleur
- Coloured ink (i.e. other than blue or black)/
Encre de couleur (i.e. autre que bleue ou noire)
- Coloured plates and/or illustrations/
Planches et/ou illustrations en couleur
- Bound with other material/
Relié avec d'autres documents
- Tight binding may cause shadows or distortion
along interior margin/
La reliure serrée peut causer de l'ombre ou de la
distortion le long de la marge intérieure
- Blank leaves added during restoration may
appear within the text. Whenever possible, these
have been omitted from filming/
Il se peut que certaines pages blanches ajoutées
lors d'une restauration apparaissent dans le texte,
mais, lorsque cela était possible, ces pages n'ont
pas été filmées.
- Additional comments:
Commentaires supplémentaires:

- Coloured pages/
Pages de couleur
- Pages damaged/
Pages endommagées
- Pages restored and/or laminated/
Pages restaurées et/ou pelliculées
- Pages discoloured, stained or foxed/
Pages décolorées, tachetées ou piquées
- Pages detached/
Pages détachées
- Showthrough/
Transparence
- Quality of print varies/
Qualité inégale de l'impression
- Includes supplementary material/
Comprend du matériel supplémentaire
- Only edition available/
Seule édition disponible
- Pages wholly or partially obscured by errata
slips, tissues, etc., have been refilmed to
ensure the best possible image/
Les pages totalement ou partiellement
obscurcies par un feuillet d'errata, une pelure,
etc., ont été filmées à nouveau de façon à
obtenir la meilleure image possible.

This item is filmed at the reduction ratio checked below/
Ce document est filmé au taux de réduction indiqué ci-dessous.

10X	14X	18X	22X	26X	30X
<input type="checkbox"/>	<input type="checkbox"/>	<input checked="" type="checkbox"/>	<input type="checkbox"/>	<input type="checkbox"/>	<input type="checkbox"/>
12X	16X	20X	24X	28X	32X

The copy filmed here has been reproduced thanks to the generosity of:

University of Alberta
Edmonton

The images appearing here are the best quality possible considering the condition and legibility of the original copy and in keeping with the filming contract specifications.

Original copies in printed paper covers are filmed beginning with the front cover and ending on the last page with a printed or illustrated impression, or the back cover when appropriate. All other original copies are filmed beginning on the first page with a printed or illustrated impression, and ending on the last page with a printed or illustrated impression.

The last recorded frame on each microfiche shall contain the symbol \rightarrow (meaning "CONTINUED"), or the symbol ∇ (meaning "END"), whichever applies.

Maps, plates, charts, etc., may be filmed at different reduction ratios. Those too large to be entirely included in one exposure are filmed beginning in the upper left hand corner, left to right and top to bottom, as many frames as required. The following diagrams illustrate the method:

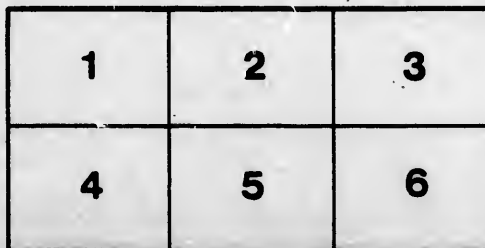
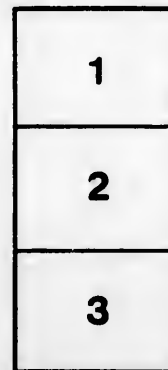

L'exemplaire filmé fut reproduit grâce à la générosité de:

University of Alberta
Edmonton

Les images suivantes ont été reproduites avec le plus grand soin, compte tenu de la condition et de la netteté de l'exemplaire filmé, et en conformité avec les conditions du contrat de filmage.

Les exemplaires originaux dont la couverture en papier est imprimée sont filmés en commençant par le premier plat et en terminant soit par la dernière page qui comporte une empreinte d'impression ou d'illustration, soit par le second plat, selon le cas. Tous les autres exemplaires originaux sont filmés en commençant par la première page qui comporte une empreinte d'impression ou d'illustration et en terminant par la dernière page qui comporte une telle empreinte.

Un des symboles suivants apparaîtra sur la dernière image de chaque microfiche, selon le cas: le symbole \rightarrow signifie "A SUIVRE", le symbole ∇ signifie "FIN".

Les cartes, planches, tableaux, etc., peuvent être filmés à des taux de réduction différents. Lorsque le document est trop grand pour être reproduit en un seul cliché, il est filmé à partir de l'angle supérieur gauche, de gauche à droite, et de haut en bas, en prenant le nombre d'images nécessaire. Les diagrammes suivants illustrent la méthode.

ROOM
440

Fe

EX LIBRIS
UNIVERSITATIS
ALBERTAENSIS

THE



science
TA
151
C22
1898

E

2543768

←←← **E**LEVATORS
REPAIRED ANYWHERE
IN CANADA.

Full Lines of
ELEVATOR SUPPLIES
and
SPECIAL ELEVATOR CABLES.

W
AN
C

Tr
Re
St
No
Mo
Le

T

ROOM
440

7 50 /
1976

WHOLESALE
AND RETAIL

COAL AND WOOD

Try our
Reynoldsville
Steam Coal.

No Clinkers.

Most Steam.

Less Labor.



Our Pittston
Anthracite,
Equalled by
Few,
Excelled by
None.

CONGER COAL CO.,

TORONTO, ONT. LIMITED,

Fensom Elevator Works,

50, 52, 54, 56 DUKE STREET,
TORONTO, ONTARIO.

MANUFACTURERS OF
THE FENSOM STANDARD

ELEVATORS

←←← **E**LEVATORS
REPAIRED ANYWHERE
IN CANADA.

Full Lines of
ELEVATOR SUPPLIES
and
SPECIAL ELEVATOR CABLES.

ROOM
A40

7 50 /
1976

WHOLESALE
AND RETAIL

COAL AND WOOD

Try our
Reynoldsville
Steam Coal.

—
No Clinkers.

—
Most Steam.

—
Less Labor.



Our Pittston
Anthracite,
Equalled by
Few,
Excelled by
None.

CONGER COAL CO.,

TORONTO, ONT.

LIMITED,

12 GOLD MEDALS FOR
ROGERS' HIGH-CLASS

"PEERLESS"

CYLINDER
ENGINE AND
DYNAMO



First-Class Oils always supplied and
Satisfaction Guaranteed.

SALES AGENTS FOR THE STANDARD OIL CO.'S
"CAPITOL" CYLINDER,
"RENOWN" ENGINE
AND "ATLANTIC RED" OIL.

Headquarters for Spirits of Turpentine, Linseed Oil, Gasoline, Benzine, Lard Oil, Axle Grease, Cup Grease, Steam Refined Seal, Bolt Cutting and other Oils.

The only firm in Canada who manufacture the Genuine
"STAR BOILER COMPOUND"
Guaranteed to remove the hardest scale without damage to the boiler or no charge for the Compound.

Send for Samples. Examine Qualities. Our Travellers will have pleasure in calling on you.

THE QUEEN CITY OIL CO., LIMITED,
SAMUEL ROGERS,
PRESIDENT. TORONTO.

W. F. Webb

Engineers' Manual

Compiled by
the

Canadian Association
of
Stationary Engineers,

Toronto, No. 1.



INTELLIGENCE

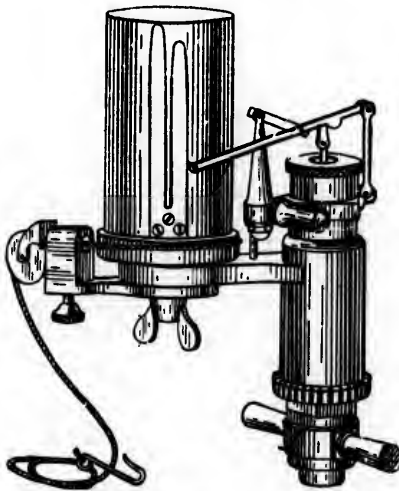

S
A
F
E
T
Y

E
C
O
N
O
M
Y

RELIABILITY



TORONTO, CANADA.

*W. J. Webb
Lawlor Building
King & Yonge
Toronto*

THE **NORTHEY**
MANUFACTURING CO.
LIMITED.

Make all Classes of

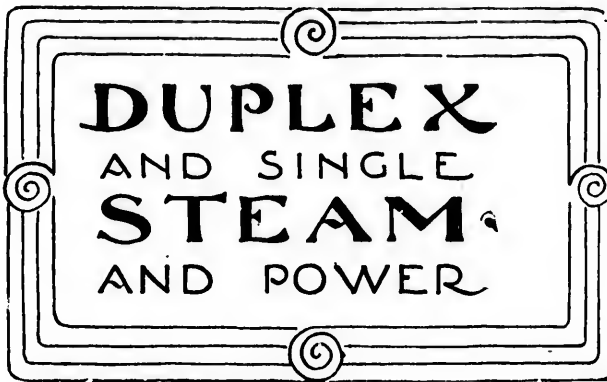

PUMPS.

•
Write for Catalogue.
•

KING STREET
SUBWAY.

TORONTO.



...Preface...



IN preparing this Manual no compunction has been felt in quoting from well-known authors, as the principles of engineering leave little room for originality. This book, however, is rather the outgrowth of the educational feature of our meetings and represents an accumulation of information discussed by our members. Although great care has been taken to ensure accuracy, yet errors will unavoidably occur, and if any should be found, we shall be glad to have our attention called to them for the purpose of rectification. For a book devoted to the interests of this branch of science and presiding over a field distinctly its own, a preface seems superfluous. Still an acknowledgment to the Committee in charge, who by their zealous efforts have made it possible to publish our Manual, seems due from the Association and we extend thanks to Messrs. James Milne, A. E. Edkins, E. J. Philip, J. W. Marr, Albert Slute, A. M. Wickens, Samuel Thompson and Wilson Phillips. We also bespeak for the advertisers herein a careful consideration at the hands of the engineers in Toronto and our branch associations throughout the Dominion.

We are, very truly yours,

Canadian Association of Stationary Engineers,
Toronto, No. 1.

FOR 
SHAFTING

Any Diameter and
Length.

Hangers with Plain or
Self-Oiling Bearings.

**"Dodge" Patent Split
Friction Clutch Pulleys**

Friction Cut-off Couplings and
"Orton" Small Friction Clutch

**"Dodge" Patent
System of
Rope Transmission.**

**Belting, Pillow Blocks,
Floor Stands, and all
Power Transmission Appliances.**

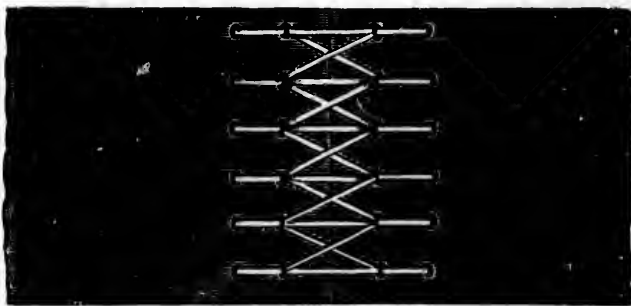
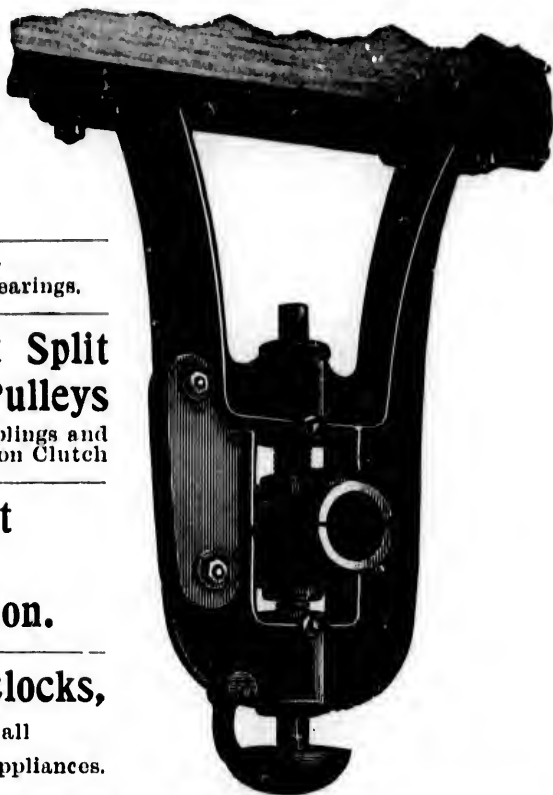

Belting, "Dodge Pulley Co.'s
Special."



"Dodge" Wood Split
Pulley.

CONSULT

**Dodge Wood
Split Pulley Co.,**

OFFICE:

74 York St., Toronto, Ont.



Compression Coupling.



...Introduction...



THE Canadian Association of Stationary Engineers is a society formed for the purpose of mutual instruction, improvement and intercourse, giving prominence to such features of education as will better enable us to thoroughly understand and perform the duties of an engineer. Founded on these principles our success has been substantial and continuous.

The parent association was founded in the City of Toronto in November, 1886, and since that time our members have steadily increased until we now have associations in all the principal cities and towns, where the number of engineers employed warrants it. The engineers and firemen of Montreal had in 1885 formed an organization for the same purpose, but soon after the starting of the C. A. S. E., joined it and accepted a charter. We are not a labor organization, neither can we be called a secret order, we invite all and especially engineers who are not members to meet with us at our lectures and readings, and we also invite our employers to join us, attend our meetings and, if they wish, take part in our discussions and debates. Our Constitution and By-Laws are based on the following preamble, which appears on page 7.

We only receive honest, industrious and sober men. Our motto being Safety, Economy, Reliability and Intelligence.

Canadian Association of Stationary Engineers,
Toronto, No. 1.

The Temperance and General Life Assurance Co'y is



THE
BEST
COMPANY
FOR
THE
BEST
RISKS

BECAUSE it offers them more favorable rates, better classification and better policies than other companies ❀ ❀ ❀ ❀ ❀ ❀

The Actual Experience of Life Companies which classify their risks as abstainers and non-abstainers has been as follows:

NAME OF COMPANY.	SAVINGS IN MORTALITY.	
	GENERAL SECTION.	TEMPERANCE SECTION.
The U. K. T. & G. P.	3. p.c.	29. p.c.
The Sceptre Life	15. "	43. "
A. T. G. M. L. A. S.	10. "	41. "

A difference of from 26 per cent. or nearly ten times as much in the T. & G. P. to 31 per cent which is only four times as much in the A. T. G.

ALL WELL-INFORMED MEN know that total abstainers on the average live much longer than non-abstainers, but all do not know that total abstainers can get distinctly lower rates for life insurance than non-abstainers by applying to The Temperance and General Life Assurance Company. ❀ ❀ ❀ ❀ ❀ ❀ ❀ ❀ ❀ ❀

The Best Company for the Best Risks.

Correspondence Solicited. Agents Wanted.

HON. G. W. ROSS,
PRESIDENT.

H. SUTHERLAND,
MANAGING DIRECTOR.

HEAD OFFICE: GLOBE BUILDING, TORONTO.



... **P**reamble...



PHIS Association shall at no time be used for the furtherance of strikes, or in any way interfering between its members and their employers in regard to wages; recognizing the identity of interests between employer and employee; not countenancing any project or enterprise that will interfere with perfect harmony between them; neither shall it be used for political or religious purposes. Its meetings shall be devoted to the business of the Association and at all times preference shall be given to the educating and helping work contemplated in the formation of the order.



The Canada Metal Co.,

(REGISTERED,)

31 William Street, TORONTO.

BABBITT,

THREE GRADES.

SOLDER,

WIRE AND HALF AND HALF.

Write for
Sample **FREE.**

State what to be
used for.



"METALLIC" ANTI-FRICTION

FLOWS LIKE WINE, FOR ALL HEAVY
WEARS LIKE STEEL, MACHINERY.



Try it!

Telephone 1729.

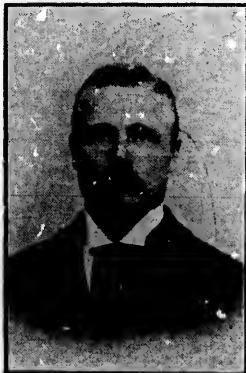

W. G. HARRIS

BUYS { COPPER, BRASS,
SCRAP { LEAD AND IRON,

25-29 WILLIAM STREET,

TELEPHONE 1729.

TORONTO.

**Officers Toronto, No. 1,
Canadian Association Stationary Engineers
1897-1898.**

Past President, - JNO. FOX.
President, - G. C. MOORING,
Recording Secretary, - JNO. W. MARR, 28 Grant St.
Financial Secretary, - J. G. BAIN.
Treasurer, - S. THOMPSON.
Conductor, - G. THOMPSON.
Doorkeeper, - T. CADWELL.

**Representatives Technical School
Board :**

E. J. PHILIP, A. M. WICKENS.

Trustees :

**J. HUGGETT, W. LEWIS,
W. G. BLACKGROVE.**



**Owners of steam and electrical plants desiring the services of competent
engineers will find it to their interest by corresponding
with our Secretary.**

SOLID COMFORT FOR ENGINEERS

LARGEST ENGINES ON THE CONTINENT OF AMERICA

Using Spooner's Box Metal

COPPERINE

Scientific Tests Disclosed Its Superiority above all other Metals.

MR. ALONZO W. SPOONER,
PORT HOPE, ONT.

MONTREAL, Aug. 7th, 1897.

DEAR SIR,—Your favor of the 30th inst. received and in reply would say we used 3,500 lbs. of your Copperine in large engines, the dimensions of which are as follows, viz.: High Pressure Cylinder, 36 x 60 inches; Low Pressure Cylinder, 64 x 60 inches; Diameter of Wheel, 24 feet; Weight of Wheel, 100 tons; Weight of Shaft, 21 tons; Weight of Pillow Blocks, 27 tons each; Total Weight, 400 tons. Will develop 4000 h.p. with 175 lbs. steam pressure.

Thanking you, we are

Yours truly,

LAURIE ENGINE CO.,
WALTER H. LAURIE, MANAGER.

CANADIAN MADE AND STUMPS THE WORLD.

R. A. KELLOND.

ESTABLISHED 1881.

KELLOND & CO.,

Solicitors of Canadian,
American,
British and Foreign

Patents.

Trade Marks and Industrial Designs Registered.

HEAD OFFICES, 12 MELINDA STREET,
TORONTO, CANADA.

Branches in all Foreign
Capitals.

ROBERT A. KELLOND,
COUNSELLOR AND
EXPERT IN PATENT CAUSES.

ENGINEERS' MANUAL.

ARITHMETIC.

Only such rules which are apt to be easily forgotten will be given here, and it is understood that some training in Arithmetic and Algebra has been previously obtained by the reader.

To Find the Greatest Common Measure (G. C. M.) or Highest Common Factor—

RULE: Divide the greater by the less; and with the remainder divide the divisor and so on until there is no remainder, and the last divisor is the G. C. M.

Example—Find the G.C.M. of 689 and 1,573. Ans. 13.

To Find the Least Common Multiple of two or more numbers—

RULE: Divide the given numbers by any number that will divide the greatest number without a remainder, and set the quotients with the undivided numbers in a line beneath. Divide the second line as before and so on until there are no two numbers that can be divided; then the product of all the divisors and last quotients will give the multiple required.

Example—Find the L.C.M. of 4, 18, 36, 72:

4	4	18	36	72
9	1	18	9	18
2	1	2	1	2
	1	1	1	1

$$\text{L.C.M.} = 4 \times 9 \times 2 = 72.$$

Example—What is the L.C.M. of 20, 36, 48, 100. Ans. 3,600.

FRACTIONS.

To reduce a Fraction to its lowest terms—

RULE: Divide both numerator and denominator by the G.C.M.

Example $\frac{2\frac{1}{2}}{\frac{3}{4}} = \frac{5}{3} = 1\frac{2}{3}$.

To change an Improper Fraction to a Mixed Number—

RULE: Divide numerator by the denominator and the remainder placed over the denominator is the fraction, viz., $\frac{29}{3} = 9\frac{2}{3}$.

To change a Mixed Number to an Improper Fraction—

RULE: Multiply the whole number by the denominator of the fraction and to the product add the numerator; place the sum over the denominator, viz., $6\frac{1}{2} = \frac{13}{2}$.

The Canadian Rubber Company, of Montreal,

MANUFACTURE FINEST
QUALITY

RUBBER BOOTS AND RUBBER SHOES.



All Kinds of **Rubber Hose** Made with our Patent Process
Seamless Tube.
Rubber Valves, Packings, Gaskets, etc., etc.



Superior Quality **Rubber Belting**, The following Grades:
Extra Star. Extra Heavy
Star. Fine Para, C. R. Co. Stitched. Forsyth
Patent Seamless.



HEAD OFFICE AND FACTORIES:
MONTREAL.

BRANCHES:
TORONTO AND WINNIPEG.

To Reduce a Compound to a Simple Fraction—

RULE: Multiply the numerators together for a new numerator, and the denominators together for a new denominator, and then reduce to its lowest terms.

Example— $\frac{9}{7}$ of $\frac{14}{10}$ of $\frac{1}{3} = \frac{9 \times 14}{7 \times 10} = 1\frac{2}{5}$.

To Divide Fractions—

RULE: Reduce to the form of simple fractions, invert divisor and proceed as in multiplication.

Example— $\frac{2}{3}$ of $1\frac{2}{3} = \frac{2}{3}$ of $\frac{7}{3} = \frac{2 \times 7}{3 \times 3} = \frac{14}{9} = 1\frac{5}{9}$.
 $\frac{2}{3} \times 3\frac{1}{3} = \frac{2}{3} \times \frac{10}{3} = \frac{20}{9} = 2\frac{2}{9} \times \frac{3}{3} = \frac{66}{9}$.

To Add Fractions—

RULE: Reduce all to a common denominator, then add the numerators, and place the sum over the common denominator.

Add $\frac{2}{3} + \frac{3}{5} + \frac{3}{10} = \frac{12 + 15 + 9}{30} = \frac{36}{30} = 1\frac{1}{5}$.

To Subtract Fractions—

RULE: Reduce them to a common denominator, subtract the numerators and place the difference over the common denominator.

$\frac{2}{3} - \frac{3}{5} = \frac{16 - 15}{40} = \frac{1}{40}$.

To Add Decimals—

RULE: Set down the figures so that the decimal points are one above the other, then proceed as in addition.

$$\begin{array}{r} 12.6798 \\ .0346 \\ 1.32 \\ .0035 \\ 5.3621 \\ \hline 19.4000 \end{array}$$
To Subtract Decimals—

RULE: Set down the figures so that the decimal points are above one another, and then proceed as in simple subtraction.

$$\begin{array}{r} 12.7896 \\ 6.6794 \\ \hline 6.1102 \end{array}$$
To Multiply Decimals—

RULE: Proceed as in simple multiplication, then point off as many decimal places as there are in the multiplier and multiplicand.

$$\begin{array}{r} 2.03 \\ .76 \\ \hline 1218 \\ 1421 \\ \hline 1.5428 \end{array}$$

JAS. R. ANNETT,
MANAGER.

JOHN J. MAIN,
SUPT. AND TREAS.



The
**Canadian Heine
Safety Boiler Co.,**

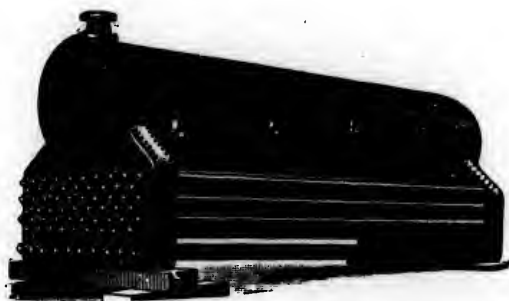

**Esplanade, Opposite Sherbourne Street,
TORONTO.**



**WATER TUBE STEAM BOILERS FOR ALL PRESSURES,
DUTIES AND FUELS.**

To Divide Decimals—

RULE: Divide as in whole numbers and point off in the quotient as many decimal places as those in the dividend exceed those in the divisor. Ciphers must be added to the dividend to make its decimal places at least equal to those in the divisor, and as many more as it is desired to have in the quotient.

Example, $33 \div .055 = \frac{33000}{55} = 600$, or $.33 \div .55 = .006$.

To Convert a Decimal into a Vulgar Fraction—

RULE: Put down the decimal as the numerator and place as the denominator 1 with as many ciphers as there are decimal places in the numerator.

$$.75 = \frac{75}{100} = \frac{3}{4}.$$

To Convert a Vulgar into a Decimal Fraction—

RULE: Divide the numerator by the denominator, adding as many ciphers prefixed by a decimal point as are necessary to give the number of decimal places desired in the result.

$$\frac{1}{4} = 1.00 \div 4 = .25.$$

To Reduce a Repeating Decimal to a Vulgar Fraction—

RULE: Subtract the decimal figures that do not repeat from the whole decimal, including one set of repeating figures; set down the remainder as the numerator of the fraction, and as many nines as there are repeating figures followed by as many ciphers as there are non-repeating figures in the denominator.

Example, $.633 = \frac{633}{6}$
 $.57 = \frac{57}{99} = \frac{19}{33}.$

ALGEBRA.

Algebra is the science which teaches the use of symbols to denote numbers and the operations to which the numbers may be subject.

Example—Add to a the sum of b and c
 $a + (b + c).$ Ans. $a + b + c.$

Subtract the number b from $a.$ Ans. $a - b.$

(I.) When a bracket is preceded by the sign $+$ remove the bracket and leave the terms unaltered.

(II.) When a bracket is preceded by the sign $-$ remove the bracket and change the sign of each term in it.

$$\text{Thus } a + b + (c - d + e - f) = a + b + c - d + e - f$$

$$\text{and } a + b - (c - d + e - f) = a + b - c + d - e + f.$$

(I.) In addition attach the lower line to the upper with the signs of both lines unchanged.

THE POLSON IRON WORKS,

TORONTO, CANADA.

Manufacturers
of
Engines and Boilers
For Every Service.

Steel Shipbuilders.

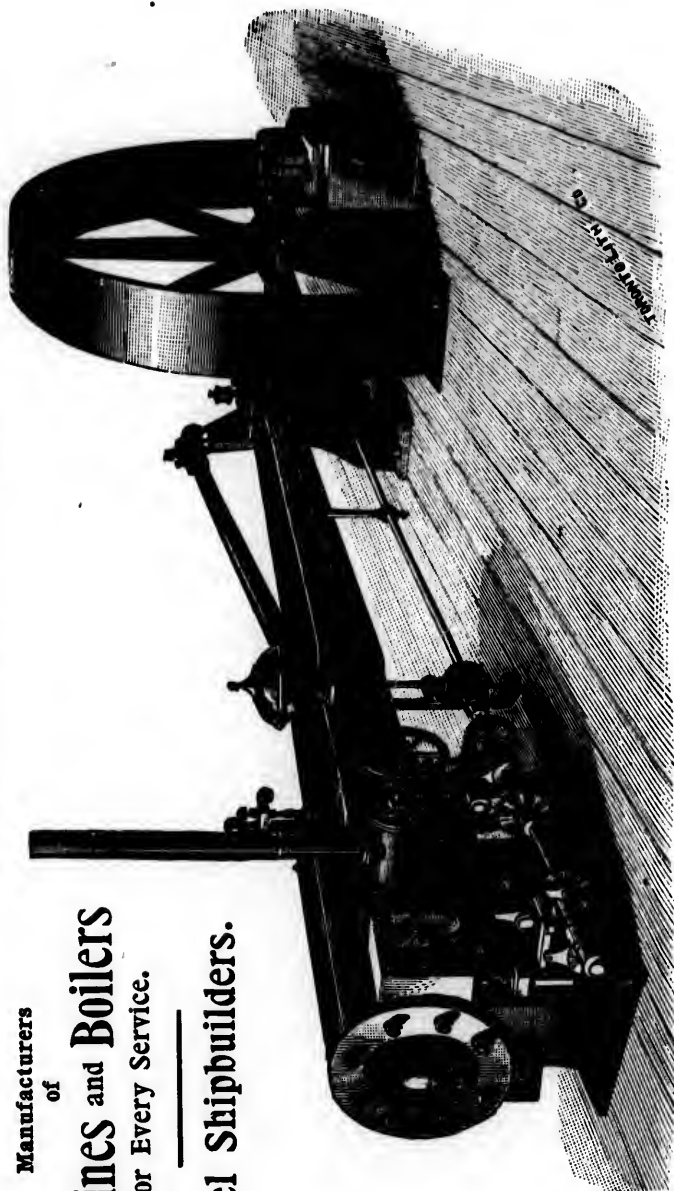

(II.) In subtraction attach the lower to the upper line with the signs of the lower line changed.

Example, (1) To $a+b+7$
add $a-b-5$
 $\frac{2a \quad +2}{}$

(2) From $a+b+7$
 $\frac{a-b-6}{}$
 $\frac{2b+13}{}$

The methods of denoting brackets are various. Thus, besides the marks (), the marks [] or { } are often used. Sometimes the "vinculum" is drawn over the symbols which are to be connected. thus: $a - \overline{b+c}$ is used to represent the same expression as $a - (b+c)$. In removing brackets from an expression, commence with the innermost and remove them one by one, and the outermost last of all.

Thus, $a - [b + \{c - (d - e + f)\}]$
 $= a - [b + \{c - (d - e - f)\}]$
 $= a - [b + \{c - d + e + f\}]$
 $= a - [b + c - d + e + f]$
 $= a - b - c + d - e - f$
 or $5x - (3x - 7) - \{4 - 2x - (6x - 3)\}$
 $= 10x.$

Multiplication—When the factors multiplied have like signs, prefix + and when unlike - to the product.

Multiply $a+b$ by $a-b$; and $a-b$ by $a-b$

$$\begin{array}{r} a+b \\ a-b \\ \hline a^2+ab \\ -ab-b^2 \\ \hline a^2-b^2 \end{array} \qquad \begin{array}{r} a-b \\ a-b \\ \hline a^2-ab \\ -ab+b^2 \\ \hline a^2-2ab+b^2 \end{array}$$

Involution.—This is the operation of multiplying a quantity by itself any number of times.

a^2 is called the second power of a .
 a^3 is " " " third " " a .

The signs of *even* powers of a negative quantity will be positive and of the *odd* powers negative.

$$\begin{aligned} (-a)^2 &= (-a)(-a) = a^2 \\ (-a)^3 &= (-a)(-a)(-a) = -a^3. \end{aligned}$$

To raise a simple quantity to any power. Multiply the index of the quantity by the number denoting the power to which it is to be raised and prefix the proper sign.

Thus the square of a^3 is a^6
 " cube of a^3 is a^9
 " " of $-x^2yz^3$ is $-x^6y^3z^9$.
 $(a+b)^2 = a^2 + 2ab + b^2$

Grand Trunk



Railway

System.

THE GREAT COMMERCIAL HIGHWAY.

4,186 MILES OF TRACK, UNDER ONE MANAGEMENT, BETWEEN THE ATLANTIC AND CHICAGO AND MILWAUKEE.

Passing through all the Principal Cities and Towns of Canada, viz.: Windsor, Chatham, London, Hamilton, Toronto, Kingston, Montreal, Quebec, and Halifax; and reaching the principal points in the United States—Chicago and West via the famous St. Clair Tunnel; Buffalo, Rochester, New York, Philadelphia, etc., via Grand Trunk new single arch, double track steel bridge over Niagara River; and Boston, Portland and Atlantic Coast Cities via the World-renowned Victoria Tubular Bridge.

The Tourists' Favorite Line

No other line can bring within your reach so many attractions. Call on the nearest agent of the Grand Trunk Railway System for Folders and Tourist Guides.

CHAS. M. HAYS,
Gen. Manager.

GEO. B. REEVE,
Gen. Traffic Manager.

W. E. DAVIS,
G. P. & T. Agent.

GEO. T. BELL,
Asst. Gen. P. & T. Agt.

D O. PEASE.
Dist. Pass. Agent,
Montreal.

M. C. DICKSON,
Dist. Pass. Agent,
Toronto.

GENERAL OFFICES, MONTREAL, P.Q.

or the square of the sum of two numbers is equal to the sum of their squares and twice their product.

$$\begin{aligned}(a + b)^3 &= a^3 + 3a^2b + 3ab^2 + b^3 \\ (a + b)^4 &= a^4 + 4a^3b + 6a^2b^2 + 4ab^3 + b^4\end{aligned}$$

which show that the indices of a decrease by unity in each term and that the indices of b increase by unity in each and the numerical coefficient of the 2nd term is always the same as the index of the power to which the binomial is raised.

$$(a - b)^2 = a^2 - 2ab + b^2$$

or the square of the difference of two numbers is equal to the sum of their squares—twice their product.

$(a - b)(a + b) = a^2 - b^2$. or the product of the sum and difference of two numbers is equal to the difference of their squares.

Division.—When the dividend and the divisor have the same sign the quotient is positive, and when they have different signs the quotient is negative.

The following will show the process in easy examples :

$$\begin{array}{r} \text{Divide } x^6 - y^6 \text{ by } x^2 - y^2 \\ x^2 - y^2 \overline{) x^6 - y^6} \quad (x^4 + x^2y^2 + y^4 \\ \underline{x^6 - x^4y^2} \\ x^4y^2 - y^6 \\ \underline{x^4y^2 - x^2y^4} \\ x^2y^4 - y^6 \\ \underline{x^2y^4 - y^6} \\ 0 \end{array}$$

$$\begin{array}{r} \text{Divide } x^6 - 4a^2x^4 + 4a^4x^2 - a^6 \text{ by } x^2 - a^2 \\ x^2 - a^2 \overline{) x^6 - 4a^2x^4 + 4a^4x^2 - a^6} \quad (x^4 - 3a^2x^2 + a^4 \\ \underline{x^6 - a^2x^4} \\ -3a^2x^4 + 4a^4x^2 - a^6 \\ \underline{-3a^2x^4 + 3a^4x^2} \\ a^4x^2 - a^6 \\ \underline{a^4x^2 - a^6} \\ 0 \end{array}$$

Simple Equations—

An equation is a statement that two expressions are equal. A simple equation is one which contains the *first power* only of an unknown quantity.

Any term of an equation may be transferred from one side to the other *if its sign is changed*.

Example, $5x - 8 = 3x + 2$.

Transposing the terms we get $5x - 3x = 2 + 8$.

Combining like terms, $2x = 10$.

And dividing both sides by 2 we get $x = 5$.

In a company of 266 persons, composed of men, women, and children, there are twice as many men as there are women, and twice

Office and Yard :
FRONT ST. NEAR BATHURST.
 Telephone No. 132.

Office and Yard :
PRINCESS STREET DOCKS.
 Telephone No. 190.

ESTABLISHED 1856.

P. BURNS & CO.

WHOLESALE AND RETAIL
 DEALERS IN

COAL AND WOOD

Reynoldsville Steam Coals
 from the Eleanora and Soldier Run Mines,
 our specialty.

HEAD OFFICE :

38 King Street East, Telephone 131.

BRANCH OFFICES :

572 Queen St. West,
 Telephone 139.

304 Queen St. East,
 Telephone 134.

388½ Yonge St.,
 Telephone 151.

429 Spadina Ave.,
 Telephone 2110.

274 College St.
 Telephone 4179.

Cor. Bleecker & Wellesley Sts.,
 Telephone 4483.

as many women as children How many are there of each ?

Let x = number of children ;

$2x$ = number of women ;

$4x$ = number of men.

$$\therefore 4x + 2x + x = 266.$$

$$7x = 266.$$

$$x = 38 \text{ children ;}$$

$$76 \text{ women ;}$$

$$152 \text{ men.}$$

Example—A vessel can be filled in 15 minutes by 3 pipes, one of which lets in 10 gallons more and the other 4 gallons less than the third each minute. The cistern holds 2400 gallons. How much comes through each pipe in a minute ?

Ans.: 1st pipe $51\frac{1}{3}$ gallons per minute ;

2nd pipe $61\frac{1}{3}$ gallons per minute ;

3rd pipe $47\frac{1}{3}$ gallons per minute.

When several unknown quantities are to be determined, there must be as many independent equations as there are unknown quantities.

Thus $a + b = 6$, from which we could not determine the definite value of a and b . We must have a second equation independent of the first, then find a pair of values of a and b which will satisfy both equations.

If we give $a - b = 2$ we can find the values

$$a + b = 6$$

$$a - b = 2$$

By addition $2a = 8$

$$a = 4$$

And by subtraction we get $a + b = 6$

$$a - b = 2$$

$$2b = 4$$

$$b = 2$$

Example, $3x + 7y = 67$

$$5x + 4y = 58$$

Multiply first equation by 5 and the second by 3.

$$15x + 35y = 335$$

$$15x + 12y = 174$$

Subtracting $23y = 161$

$$y = 7$$

and since $5x + 4y = 58$

and substituting the value of y from above we get :

$$5x + 28 = 58$$

$$5x = 30$$

$$x = 6$$

If there are three unknown quantities their values may be found by three independent equations. For from two of the equations a third which involves only two unknown symbols may be found, and from the remaining equation, and one of the others, a *fourth* containing only the *same two* unknown symbols may be found.

The
Bennett & Wright Co.,
Limited.

*Engineers and
Contractors.*

*Steam and Hot Water,
Heating and Ventilating,
Fine Sanitary Plumbing,
Electric Light Wiring, etc.,
Automatic Sprinklers for
Fire Protection,
Pneumatic Cash Systems,
Gas and Electric Fixtures.*



Queen and Dalhousie Sts.,

TORONTO.

QUADRATIC EQUATIONS.

A quadratic equation is one into which the square of an unknown symbol enters with or without the first power of the symbol.

$$\begin{array}{l} \text{Thus} \quad x^2 = 9 \\ \text{and} \quad x^2 + 5x = 24 \end{array}$$

are quadratic equations.

$x^2 = 9$ is a pure quadratic equation.

$x^2 + 5x = 24$ is an affected quadratic equation.

Every pure quadratic equation has two roots equal in magnitude but with different signs.

$$\begin{array}{l} x^2 = 16 \\ \therefore x = \pm 4 \end{array}$$

Affected Quadratic Equations are solved by adding certain terms to both sides of the equation so as to make the left hand a perfect square.

$$\text{Thus} \quad x^2 + 6x = 72$$

By adding 9 to each side we get

$$x^2 + 6x + 9 = 72 + 9$$

Extracting square root we have $x + 3 = \pm 9$

$$x = 6 \text{ or } -12$$

Example—A ladder, whose foot rests in a given position, just reaches a window on one side of a street, and when turned about its foot just reaches a window on the other side. If the two positions of the ladder be at right angles to each other and the heights of the windows be 36 and 27 feet respectively, find the width of the street and the length of the ladder.

ARITHMETICAL PROGRESSION.

Arithmetical Progression is a series of numbers which increase or decrease by a constant difference.

Thus, 2, 4, 6, 8, 10
9, 7, 5, 3, 1, are arithmetical progressions.

Let a = first term.
 d = difference.
 n = number of terms.
 s = sum of terms.
 x = last term.

To Find the Last Term—

$$\text{Formula, } x = a + (n - 1)d$$

To Find the Sum—

$$\begin{aligned} \text{Formula, } s &= \frac{n}{2}(a + x) \\ &= \frac{n}{2}\{2a + (n - 1)d\} \end{aligned}$$

To Find the Number of Terms—

$$\text{Formula, } n = \frac{2s}{a + x} = \frac{x - a}{d} + 1$$

PATENTS

All Countries.



Fetherstonhaugh & Co.,
Patent Barristers, Solicitors and Experts,
Engineers and Draughtsmen,
General Patent Office.

Head Office, Canadian Bank of Commerce Building,
King Street West,

TORONTO, CANADA.

Offices in Montreal, Ottawa and Washington, U.S.

VACUUM
OIL CO.

LUBRICATING
OILS.

OFFICES :
FRONT AND SCOTT STS.,
TORONTO.



To Find the First Term—

$$\text{Formula, } a = x - (n - 1)d = \frac{2s}{n} - x$$

Example—Find the last term of the series, also the sum,
7, 10, 13, to 20 terms.

Ans. 64, 710.

GEOMETRICAL PROGRESSION.

Geometrical Progression is a series of numbers which increase or decrease by a constant factor.

3, 6, 12, 24, 48
16, 4, 1, $\frac{1}{4}$, $\frac{1}{16}$ are Geometrical Progressions.

The constant factor is usually called the Common Ratio.

Let a = first term.

f = common ratio.

n = number of terms.

s = sum of the n terms.

x = last term.

To Find the Last Term—

$$\text{Formula, } x = af^{n-1}$$

To Find the Sum—

$$\text{Formula, } s = \frac{a(f^n - 1)}{f - 1} = \frac{fx - a}{f - 1}$$

To Find the First Term—

$$\text{Formula, } a = \frac{x}{f^{n-1}} = fx - (f - 1)s$$

To Find the Common Factor—

$$\text{Formula, } f = \frac{s - a}{s - x} = \sqrt[n-1]{\frac{x}{a}}$$

Example—Insert 3 Geometric means between 1 and 16.
From this we get $s = 5$, and the common factor,

$$f = \sqrt[n-1]{\frac{x}{a}} = \sqrt[4]{\frac{16}{1}} = 2$$

Ans. 1, 2, 4, 8, 16.

Example—Find the sum of 1, 3, 9, to 6 terms.

Ans. 364.

EVOLUTION.

Evolution is the operation of finding any root of a given number. In involution the base and the exponents are given and the power is determined therefrom. In evolution the base is to be determined,

All Work done under my
personal supervision.

Telephone 2867.

JOHN H. SHALES,
MILLWRIGHT
AND ELEVATOR
SPECIALIST,

Confederation Life Building,

TORONTO.

Elevator Supplies always on hand.

Agent for MILLER BROS. & TOMS
Electric Hydro-Steam and Hydraulic
ELEVATORS.

REPAIRS A
SPECIALTY.

G. T. PENDRITH & Co.,

MANUFACTURERS OF

STEAM TRAPS, PIPE CUTTING
MACHINES,
DOUGH MIXERS AND BRAKES,
BUFFING AND POLISHING LATHES,
SHAFTING, HANGERS AND
SPECIAL MACHINERY.

Also the "SUN" BICYCLE
A strictly high grade wheel.

73 to 81 ADELAIDE ST. WEST,

TORONTO.

the power itself being given and also the exponent or index of its degree. By prefixing the symbol $\sqrt{\quad}$ denotes the square root of the given number; $\sqrt[3]{\quad}$ denotes the cube root; $\sqrt[5]{\quad}$ denotes the 5th root. Fractional exponents are also used to denote the roots of the numbers

as $81^{\frac{1}{4}}$, $64^{\frac{1}{3}}$, $32^{\frac{1}{2}}$, which is the same as $\sqrt[4]{81}$, $\sqrt[3]{64}$, $\sqrt[2]{32}$.

The 4th root is the square root of the square root.

The 6th root is the square root of the cube root.

The 9th root is the cube root of the cube root.

To extract the square root of 123456.789, commence at the decimal point and mark off the given number into periods of two places each in the two directions and add as many ciphers as may be necessary, as 123456.789000

Find the greatest number whose square is less than the first left hand period, and place it as the first figure in the quotient. Subtract its square from the left hand period and to the remainder bring down the two figures of the second period. Double the first figure of the quotient for part of the next divisor; ascertain how many times the latter is contained in the dividend exclusive of the right hand figures, and set the figure representing that number of times as the second figure in the quotient, and annex to the right of the partial divisor forming now the complete divisor. Multiply the divisor by the second figure in the quotient, and subtract the product from the dividend. To the remainder bring down the next period and proceed as before, in each case doubling the figures in the root to obtain the trial divisor.

$$\begin{array}{r}
 123456.789000 \quad \underline{351.36418} \\
 9 \\
 \hline
 65 \quad 334 \\
 \quad 325 \\
 \hline
 701 \quad 956 \\
 \quad 701 \\
 \hline
 7023 \quad 25578 \\
 \quad 21069 \\
 \hline
 70266 \quad 450990 \\
 \quad 421596 \\
 \hline
 702724 \quad 2939400 \\
 \quad 2810896 \\
 \hline
 7027281 \quad 12850400 \\
 \quad 7027281 \\
 \hline
 70272828 \quad 582311900 \\
 \quad 562182604 \\
 \hline
 \end{array}$$

The square root of 123456.789 is 351.36418 which can readily be proved by squaring this number.

THE
JOHN ABELL ENGINE & MACHINE WORKS CO.,
 LIMITED,

The Abell Automatic Engine,

Medal Winner at Chicago, 1893.

Plain Portable Engines, Compound Portable Engines, Plain Traction Engines
 Compound Traction Engines.

Boilers, Tanks. Saw Mills, Roller Mills.

Dynamos, Motors, Arc Lamps.

Sales Agents for the Dominion for the Shelby Incandescent
 Lamps.

GRATE BARS.

THE JOHN ABELL ENGINE & MACHINE WORKS CO., LIMITED,
TORONTO, CANADA.

FOULDS & CO.,



PATENT ATTORNEYS and
EXPERTS,
ENGINEERS and DRAUGHTSMEN.



Head Office :
 Confederation Life Building,
 TORONTO.

Branch :
 MANCHESTER, ENG.

To extract the square root of a vulgar fraction extract the square root of numerator and denominator $\sqrt{\frac{1}{16}} = \frac{1}{4} = \frac{1}{4}$, or convert the vulgar into a decimal fraction and extract the root $\sqrt{\frac{1}{16}} = \sqrt{.0625} = .25$ or $\frac{1}{4}$.

To extract the square root of large numbers it is easier done by logarithms.

Example,

$$\sqrt{107506}$$

$$\text{Log. of } 107506 = 5.03143270$$

$$\text{Divide by } 2 = 2.51571635$$

$$\text{Log. } 2.51571635 = 327.88 = \text{square root.}$$

PRACTICAL GEOMETRY.

To divide a given triangle ABC into any number of equal parts by lines parallel to AB :

Divide BC into the required number of parts; upon BC describe a semicircle, raise perpendiculars from the points of division, meeting the semicircle, with C as centre; describe arcs from the points of intersection of the perpendiculars and the semicircle cutting BC in 1, 2, 3, 4, etc. Draw parallels to AB from 1, 2, 3, 4.

To divide a triangle into any number of equal parts through the apex:

Divide the base into the required number of parts and join the points of division to the apex. The triangles thus formed have equal bases and equal altitudes, therefore their areas are equal.

To bisect any irregular figure by a line drawn from one of its corners:

Let $ABCD$ be the given figure, and A the given corner. Draw the diagonals AC and BD . Bisect BD in F , and through the point F , draw FG cutting BC in G . Join AG and the figure is bisected.

To divide a square into any number of equal parts by lines drawn through one of its corners:

Let $ABCD$ be the required square. Divide the side BC into the required number of parts (say 5), marking the points 1, 2, 3, 4, 5, and do the same with the side CD marking the points 6, 7, 8, 9, the mark 5 will be at the corner C . Join 2, 4, 6, 8, to the corner A and the figure will be divided as required.

MENSURATION OF SURFACES.

To Find the Area of a Triangle—

Case I. When base and perpendicular are given.

RULE: Multiply the base by the perpendicular and divide by 2.

$$\text{Area} = \frac{\text{base} \times \text{perpendicular}}{2}$$

and by transposition we get

$$\text{Base} = \frac{2 \text{ Area}}{\text{Perpendicular}}$$

$$\text{Perpendicular} = \frac{2 \text{ Area}}{\text{Base}}$$

The
James Morrison
Brass Mf'g Co.,
 Limited,

89-97 Adelaide Street West,
TORONTO.

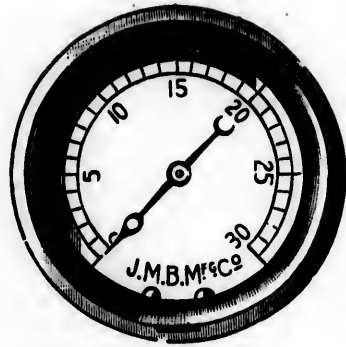

Manufacturers of and Dealers in



**Every Description of Engineers,
 Steam Fitters, Plumbers and
 Gas Fitters' Brass Work.
 Steam, Vacuum, Hydraulic and
 Recording Gauges and Engineers'
 Clocks.**

Sole Manufacturers of the famous lines of

**J. M. T. Globe, Angle, Gate and Check
 Valves,**

Which are acknowledged by Engineers on Locomotives, Marine, Stationary and Portable Engines, to be the best Valves manufactured in Canada or the United States. In the construction of which only the **Best Metal** is used and the **Best Workmen Employed**. We can recommend these Valves to all steam users with perfect confidence, as they have given satisfaction to every one who has used them.

A full line of Lubricators, Oil Cups, Grease Cups, Oiling Devices of the most approved kinds kept in stock or made to order. Hancock Inspirators, Gresham & Penberthy Injectors and Ejectors, W. I. Pipe, Malleable and Cast Iron Fittings, $\frac{1}{8}$ to 10 inches, constantly in stock.

While quality, not cheapness in our goods, is our guiding star, our prices will be found (quality considered) as low as the lowest.

The JAMES MORRISON BRASS M'FG CO., Limited,
89-97 ADFLAIDE STREET WEST, TORONTO.

Case II. When the three sides are given.

RULE: From half the sum of the three sides subtract each side separately; multiply the half sum and the three remainders together, and extract the square root of the product.

Let A, B, C , represent the three sides of the triangle, and

$$\frac{A+B+C}{2} = \text{half the sum} = s$$

then the formula is

$$\sqrt{S(S-A)(S-B)(S-C)} = \text{Area.}$$

Example.—What is the area of a triangle whose sides are respectively 9, 10, 12 feet? Ans.—44.03 square feet.

To Find the Area of a Trapezoid—

RULE: Multiply half the sum of the two parallel sides by their perpendicular distance.

A trapezoid is a quadrilateral figure with only one pair of opposite sides parallel.

Example—A board 8" wide has its two parallel sides 1'-6" and 2'-3", what fraction of a square yard will it cover? Ans.— $\frac{5}{8}$ of a square yard.

To Find the Area of a Trapezium.

Case I. When a diagonal and two perpendiculars are given.

RULE I. Find the area of each triangle and take the sum.

RULE II. Multiply half the diagonal by the sum of the perpendiculars.

A trapezium is a quadrilateral figure with unequal sides.

Case II. When the diagonal and the four sides are given.

RULE: Find the area of each triangle and take the sum.

Example.—In a trapezium the diagonal is 80 yards, and the two perpendiculars are 36 and 42 yards. What is the area? Ans.—3120 square yards.

In a trapezium $ABCD$, the side AD is 18', DC 14', CB 15', and AB 12'; the diagonal AC is 18'. Find the area? Ans.—205.37 square feet.

To find the Area of a Parallelogram.

RULE: Multiply the length by the perpendicular breadth.

Formula, $L.B=A$.

The varieties of parallelograms are the

Square, having 4 sides equal and all angles right angles.

Rectangle, having opposite sides equal and all angles right angles.

Rhombus, having all 4 sides equal, opposite angles equal, but angles not right angles.

Rhomboid, having opposite sides equal, opposite angles equal, but angles not right angles.

Given the Area of a Square to find its Side.



JOHN L. BLAIKIE ESQ.
PRES.

EW. RATHBUN ESQ.
VICE. PRES.

THE BOILER INSPECTION
& INSURANCE CO.

OF CANADA

B. I. & I. CO.

CONSULTING ENGINEERS

G. C. ROBB CHIEF ENGINEER
A. FRASER SEC. TRES.

HEAD OFFICE TORONTO



Keep the
Boiler
right if you
want good
Steam.



RULE: Extract the square root of the area.

Formula, $S = \sqrt{\text{area}}$.

Example—Find in yards the side of a square whose surface is 1.5 acres. Ans.—85.2 yards.

Given the Area of a Rectangle, Rhombus, or Rhomboid, and the length or the perpendicular breadth to find the other dimension.

RULE: Divide the area by the given dimension.

Formula, $L = \frac{A}{B}$; $B = \frac{A}{L}$

To find any Side of a Right Angled Triangle, the other two being given.

Case I. When the hypotenuse is required.

RULE: Square the base and square the perpendicular, take the sum of these squares and extract the square root.

Formula, $H = \sqrt{B^2 + P^2}$.

Example.—The side of a square is 1200'. Find the diagonal. Ans.—1697 feet.

Case II. When the perpendicular or the base is required.

RULE: Square the hypotenuse and square the given leg, take the difference of these squares and extract the square root.

The formula is deducible from the last, where

$$\begin{aligned} H &= \sqrt{B^2 + P^2} \\ \therefore H^2 &= B^2 + P^2 \\ P^2 &= H^2 - B^2 \\ \therefore P &= \sqrt{H^2 - B^2} \\ B &= \sqrt{H^2 - P^2} \end{aligned}$$

Examples—

A wall is 40' high and a ditch in front of it is 25' wide. What length of ladder is required to reach from the top of the wall to opposite side of ditch? Ans.—47.1 feet.

At a distance of 15' a ladder 18' long is placed. How high will it reach? Ans.—10' nearly.

To Find the Area of a Regular Polygon.

RULE I.: Multiply the length of a side by the perpendicular distance to the centre; multiply the product by the number of sides and divide by 2, or half the perimeter multiplied by the perpendicular let fall from the centre to one of the sides.

RULE II.: Square the side and multiply by the number opposite the name of the polygon in the last column of the following table.

Formula, $s^2 \times \text{tabular number} = \text{area}$.

A polygon is a plane figure having 3 or more sides. They are termed regular or irregular, as the sides are equal or unequal.

Engineers

who understand

That a daily difference in steam-producing qualities of coal foots up largely in the profit and loss account, look closely to their fuel and note that

Our Coal is an Actual Money Saver.

The best test is actual trial. This we ask, satisfied that there is not a better coal on the market.

THE STANDARD FUEL CO. OF TORONTO,

TELEPHONE 863 AND 1836

LIMITED

The A. R. Williams Machinery Co.

LIMITED,

MANUFACTURERS AND DEALERS IN

FULL OUTFITS FOR

**Machine Shops, Railroad Shops, Plow Shops,
Foundries, Brass Shops, Planing Mills,
Furniture Factories, Saw Mills, Shingle Mills,
Lath Mills, Elevators, Contractors, Threshers.**

FULL LINES IN STOCK OF

**Engines and Boilers, Iron Tools,
Woodworking Machinery, Dynamos, Motors,
Special Machinery, Mining Machinery, Shafting,
Belting, Band Saws, Vises, Anvils, Forges,
Brass Goods, Supplies of every description.**

EITHER NEW OR SECOND HAND.

BRANCHES :

345 AND 347 ST. JAMES ST. MONTREAL.
193 COLBORNE ST., BRANTFORD.
LONDON TOOL CO., LONDON.

HEAD OFFICE :

TORONTO,
FRONT ST. WEST. OPP. QUEEN'S HOTEL.

TABLE OF REGULAR POLYGONS.

I. No. of of Sides.	II. Name of Polygon.	III. Perpendicular Radius of Inscribed Circle.	IV. Radius of Circumscrib- ing Circle	V. Length of side Radius of Cir- cumscscribed Circle = 1.	VI. Area Side = 1.
3	Eq. Triangle	.28867	.57735	1 732	.43301
4	Squares	.5	.70710	1 414	1.0000
5	Pentagon	.68819	.85065	1 1756	1.72047
6	Hexagon	.86602	1.0000	1.0000	2.59807
7	Heptagon	1.03826	1.15238	.8677	3.63391
8	Octagon	1.20710	1.30656	.7653	4.82842
9	Nonagon	1.37373	1.46190	.684	6.18182
10	Decagon	1.53884	1.61863	.618	7.69420
11	Undecagon	1.70284	1.77473	.5634	9.36564
12	Duodecagon	1.86602	1.93185	.5176	11.191615

Example—What is the area of an equilateral triangle whose side is 30 inches? Ans.—389.709 square inches.

To Find the Perpendicular Height, from the centre to one of the sides of the Polygon, or in other words, the radius of inscribed circle, which is called the Apothem.

RULE: Multiply the side by the number opposite the name in column III. in table.

Example—Find the radius of an inscribed circle in the case of a hexagon, the side being 40. Ans. 34.6408.

To Find the Radius of the Circumscribing Circle.

RULE: Multiply the side by the number opposite in column IV. in table.

Example—The side of an octagon is 8 inches. Find the *diameter* of the circumscribing circle. Ans.—20.90496 inches.

To Find the Side of a Regular Polygon when the area is given.

RULE: Divide the area by the number in last column of table and extract the square root.

$$\text{Side} = \sqrt{\frac{\text{Area}}{\text{tabular No.}}}$$

Example—The side of a square is 3 feet, what is the side of a hexagon of the same area. Ans.—1.862 feet.

To Find the Area of Irregular Polygons.

RULE: Divide the polygon into triangles and then find the sum of the areas of these triangles.

THE VALUE OF π .

Let the radius of a circle be 1, the side of the inscribed square is therefore $\sqrt{2}$ and that of the circumscribed will be equal to the diameter 2, hence the surface of the inscribed square will be 2 and that of the circumscribed will be 4.

Let S = surface of the inscribed polygon.

s = surface of the circumscribed polygon.

The Goldie & McCulloch Co.

LIMITED.

MANUFACTURERS OF
IMPROVED STEAM ENGINES AND
BOILERS.

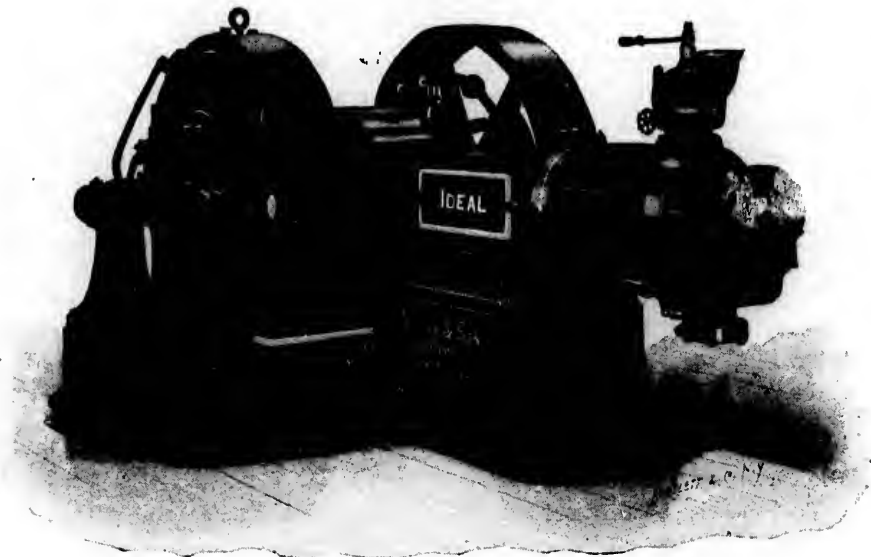

THE "IDEAL" HIGH SPEED ENGINE DIRECT-CONNECTED.

Flouring Mills, And the Erection of same in the Most Complete
Style of Modern Improvement.
Wool Machinery, Wood-Working Machinery,
Saw Mill, Shingle and Stave Machinery,
Fire and Burglar-Proof Safes and Vault Doors.

SPECIAL ATTENTION called to the "Wheelock" Improved
Steam Engine, also the "Ideal" High Speed Engine, out of
which appears above, as being Unequalled for Simplicity, Efficiency
and Economy in Working, and Especially Adapted for Electric Light-
ing, Street Railways, Etc.



GALT, ONT.

The area of an inscribed octagon whose circumscribing circle has radius $1 = .7653^2 \times 4.8284271$ (See table on page 35), $= \sqrt{8} = 2.8284271$, and the area of a circumscribed octagon $= .8285^2 \times 4.8284271 = \frac{16}{2 + \sqrt{8}} = 3.3137075$.

From these inscribed and circumscribed polygons we can easily determine the polygons having twice the number of sides.

$.S = 2.8284271$; $s = 3.3137075$, and the area of a polygon having 16 sides would be $= \sqrt{S + s} = 3.061474$ for the inscribed polygon and

$$= \frac{2S \times s}{S + 3.061474} = \frac{2 \times 2.828 \times 3.3137}{2.828 + 3.061474} = 3.1825979$$

By these polygons of 16 sides the surfaces of polygons having 32 sides can be easily determined and the process continued until the difference between the inscribed and the circumscribed is infinitesimal. Since the circle lies between these polygons it will differ from either polygon by less than the polygons differ from one another, and therefore if the figures which express the areas of the two polygons agree they will be the true figures to express the area of the circle.

The following is the computation of these polygons carried on till they agree, as far as the seventh place of decimals.

No. of Sides.	Inscribed Polygon.	Circumscribed Polygon.
4	2.0000000	4.0000000
8	2.8284271	3.3137085
16	3.0614674	3.1825979
32	3.1214451	3.1517249
64	3.1365485	3.1441184
128	3.1403311	3.1422236
256	3.1412772	3.1417504
512	3.1415138	3.1416321
1024	3.1415729	3.1416025
2048	3.1415877	3.1415951
4096	3.1415914	3.1415933
8192	3.1415923	3.1415928
16384	3.1415925	3.1415927
32768	3.1415926	3.1415926

The approximate area of a circle, having a radius 1, is therefore equal to 3.1416; *i.e.*, area of circle = radius² $\times \pi = D^2 \times \frac{\pi}{4}$. It will be observed, in the above table, that the area of the inscribed polygon gradually decreases as the number of sides increases, and the opposite with the circumscribed polygon; and it necessarily follows that, if the number of sides were increased infinitely, the two figures would ultimately agree. The above result is correct to seven places in decimal.

For all practical purposes, π is generally taken as 3.1416; but, for very fine calculation, 3.14159265359 may be taken.

To Find the Area of a Circle—

RULE I.: Square the diameter, and multiply by .7854.

RULE II.: Square the circumference, and multiply by .07958.

MECHANICAL STOKER.

Within the past two years a new device in connection with furnace firing has been brought to the attention of Canadian manufacturers; this is the Improved Jones Under Feed Mechanical Stoker.

This stoker consists of a steam ram or cylinder, with hopper for holding coal outside of furnace proper and a retort or fuel magazine inside the furnace. Into this retort fuel is forced by means of the ram. No grate bars, but dead plates are used, and all air supplied for combustion is forced by means of a blower through tuyere blocks placed on each side of the retort. The ash pit is used for an air chamber. A small auxiliary ram is placed at lowest point in bottom of retort at a point where the fire never reaches, as all of air supply comes in at grate line. By means of the rams coal is forced with even distribution underneath the fire, each charge of fuel raising the preceding charge upwards until it is forced into the fire. As the green coal lies directly underneath the burning mass of fuel above, it becomes coked and the gases are liberated. Above this coking fuel and below the burning mass the air is admitted through the tuyeres, mixed with the gases given off. The mixture of gas and air passes upwards through the burning coke and is consumed, thus giving the benefit of all the combustible matter in the fuel. It may be said that this stoker works on the principle of a Bunsen burner, which gives one of the hottest, most economical flames known to science.

By the use of this stoker only gases and coke come in contact with the fire, consequently no smoke, clean tubes, no ash. The refuse from firing passes off through the stack in the form of non-combustible gases and the minerals, sand, etc., contained in coal falling down the mound of burning fuel and upon the dead plates. The fire in ordinary cases needs to be cleaned but once a day and does not take five minutes a day for each furnace. At all other times the doors should be kept closed. All that is required of the fireman is simply to keep coal in the hoppers and handle the lever as the furnace requires stoking.

This furnace will burn any kind of bituminous coal or lignite, slack or screenings, and will fully utilize all heat-giving elements contained therein; and that whether good coal or refuse slack or screenings are used, this device when properly operated insures a substantially smokeless stack. Also the device will increase the capacity and efficiency of boilers, thereby making it possible to do more work with two stoker fired boilers than with three of the same size fired by hand, and by its use the even non-fluctuating heat saves wear and tear of the boilers, thereby adding to their durability. The use of this device requires no change in boilers proper, the only change being in the furnace. This is so small a change that installation can be made without experiencing trouble from loss of time. The work of the stoker in the largest plants in the Dominion is its own recommendation. For further information, address THE WEEKS-ELDRED CO., of Toronto, Limited, who are sole manufacturers for Canada.

To Find the Diameter when the Area is given—

RULE : Divide the area by .7854 and extract the square root ;
or, Multiply 1.12838 by the square root of the area.

The areas of circles are to each other as the squares of their diameters.

To Find the Circumference when the Area is given—

RULE : Divide the area by .07958 and extract the square root ;
or, Circumference = $\frac{\sqrt{\text{Area}}}{.07958}$

To Find the Area of a Circular Ring—

RULE : Multiply the sum of the two diameters by their difference and the result by .7854.

Formula, $(D+d)(D-d) .7854$; or,
 $(D^2-d^2) .7854$,

when D represents the larger and d the smaller diameter.

Example—What is the area of a ring formed by circles having their diameters 25' and 35' ? Ans.—471.25 square feet.

To Find the Area of an Ellipse—

RULE : Multiply the product of the two diameters by .7854.

Formula, $(D \times d) .7854$.

Example—The two diameters of an ellipse are 30' and 25'. Find the area. Ans.—589.05 square feet.

To Find the Circumference of an Ellipse or Oval—

RULE : Multiply half the sum of the two diameters by 3.1416.

Formula, $\left(\frac{D+d}{2}\right) 3.1416 = (D+d) 1.5708$.

Relation of the circle to its Equal, Inscribed and Circumscribed Square.

Diameter of circle	× .88623	= side of equal square.
Circumference of circle	× .28209	= side of equal square.
Circumference of circle	× 1.1284	= perimeter of equal square.
Diameter of circle	× .7071	= side of inscribed square.
Circumference of circle	× .22508	= side of inscribed square.
Area of circle	× .9 ÷ diameter	= side of inscribed square.
Area of circle	× 1.2732	= area of circumscribed square.
Area of circle	× .63662	= area of inscribed square.
Side of square	× 1.4142	= diam. of circumscribed circle.
Side of square	× 4.4428	= circum. of circumscribed circle.
Perimeter of square	× .88623	= circum. of circumscribed circle.
Square inches	× 1.2732	= circular inches.

To Find the Length of an Arc of a Circle—

RULE : From 8 times the chord of half the arc subtract the chord of the whole arc and take one third of the remainder.

Example—The chord of the whole arc is 18' and that of half the arc is 12'. What is the length of the arc ? Ans.—26 feet.

From the height and half the chord of the arc the chord of half

TORONTO WIRE AND IRON WORKS,

GEO. B. MEADOWS,

Proprietor,

128 King Street West, TORONTO.

(Opposite the Rossin House.)

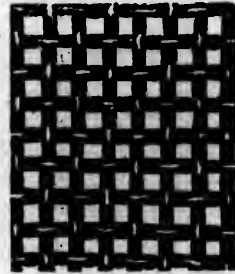

Manufacture
all Grades of

WIRE CLOTH

for Locomotive, Mining,
Foundry and
Machine purposes.

Artistic Iron and Brass Work,
Iron Railings and Wire Work of all kinds.
Electro Plating.

ESTIMATES CHEERFULLY GIVEN.

Catalogue on Application.

Positive Grip PIPE
WRENCH

Cast Steel from end to end. Jaws are Oil Tempered
and can be re-sharpened with an ordinary file.



14" takes from $\frac{1}{4}$ " to $1\frac{1}{4}$ "
24" takes from $\frac{1}{2}$ " to $2\frac{1}{2}$ "

AIKENHEAD HARDWARE CO.,
6 ADELAIDE STREET EAST.

Pipe-Tools in Great Variety.

the arc is determined in the same manner as finding the base or perpendicular of a right angled triangle.

To Find the Radius of a Circle when the chord and height of an Arc are given—

RULE: Square half the chord and divide by the height, then add the height and divide by 2.

Example—With what radius is a circular arch of a bridge to be traced whose span is 120' and rise 12.5'. Ans.—150.25 feet.

To Find the Area of a sector of a Circle—

RULE I.: Multiply the length of the arc by the radius and divide by 2.

Example—The chord is 24' and the height 6'. Find area of Sector. Ans.—208.32 square feet.

RULE II.: Area of circle multiplied by the number of degrees in the arc divided by 360.

To Find the Area of a Segment of a Circle—

RULE: Find the area of the sector having the same arc with the segment, find also the area of the triangle formed by the chord of the segment and the two radii of the sector. If the segment be greater than a semicircle, take the *sum* of these two areas; if the segment be less than a semicircle, take their difference.

AREAS OF SEGMENTS OF A CIRCLE.

The diameter of which is unity and supposed to be divided into 200 equal parts.

Height	Area.	Height.	Area.	Height.	Area.	Height.	Area.
.005	.000471	.130	.059999	.255	.157891	.380	.273861
.01	.001329	.135	.063389	.260	.162263	.385	.278721
.015	.002438	.140	.066833	.265	.166663	.390	.283593
.02	.003749	.145	.070329	.270	.171090	.395	.288476
.025	.005231	.150	.073875	.275	.175542	.400	.293370
.03	.006866	.155	.077470	.280	.180020	.405	.298274
.035	.008638	.160	.081112	.285	.184522	.410	.303187
.04	.010538	.165	.084801	.290	.189048	.415	.308110
.045	.012555	.170	.088536	.295	.193597	.420	.313042
.05	.014681	.175	.092314	.300	.198168	.425	.317981
.055	.016912	.180	.096135	.305	.202762	.430	.322928
.06	.019339	.185	.099997	.310	.207376	.435	.327883
.065	.021660	.190	.103910	.315	.212011	.440	.332843
.07	.024168	.195	.107843	.320	.216666	.445	.337810
.075	.026761	.200	.111824	.325	.221341	.450	.342783
.08	.029435	.205	.115842	.330	.226034	.455	.347760
.085	.032186	.210	.119898	.335	.230745	.460	.352742
.09	.035012	.215	.123988	.340	.235473	.465	.357728
.095	.037909	.220	.128114	.345	.240219	.470	.362717
.10	.040875	.225	.132273	.350	.244980	.475	.367719
.105	.043908	.230	.136465	.355	.249758	.480	.372704
.110	.047006	.235	.140689	.360	.254551	.485	.377701
.115	.050165	.240	.144945	.365	.259358	.490	.382709
.120	.053385	.245	.149231	.370	.264179	.495	.387699
.125	.056664	.250	.153546	.375	.269014	.500	.392699

To Calculate the Area of a Segment by the above table —

BOILER

PLATES, TUBES,

RIVETS.

❖
SHEET STEEL,
CORRUGATED GALVANIZED
IRON.

❖
ENGINEERS AND MACHINISTS'
SUPPLIES.

❖
TWIST DRILLS, EMERY WHEELS,
STOCKS and DIES, CHUCKS,
PIPE TONGS, PIPE CUTTERS,
VALVES, PIPE, Etc.

❖
RICE LEWIS & SON

LIMITED,

TORONTO.

COR. KING AND VICTORIA STS.,

RULE: Divide the height by the diameter, find the quotient in the column of heights, then get the corresponding area, multiply same by diameter of circle squared; the product is the required area.

Example I.—Diameter of circle, 5'; height of segment, 1'. Find the area of segment.

$$1 \div 5 = .2 \quad \text{Area} = .111824$$

$$\therefore .111824 \times 5^2 = 2.7956 \text{ sq. ft. or } 402.5664 \text{ sq. inches.}$$

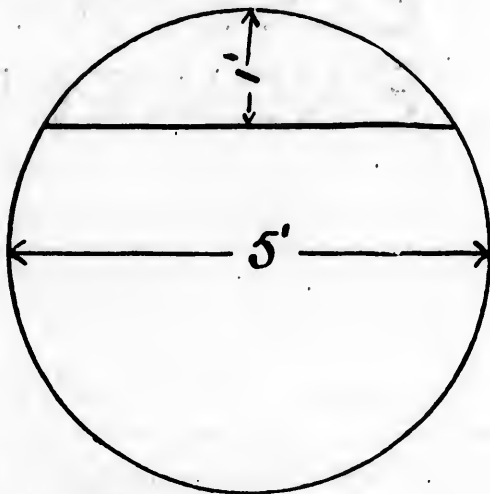

Example II.—Find the steam space in a boiler 6' diameter, height of water 4' - 3" from bottom, length 16'.

$$6' - 4' 3" = 1' 9"; \quad 1' 9" \div 6' = \frac{1.75'}{6'} = .291\bar{6}$$

$$\text{height } .295 = .193597$$

$$\text{height } .290 = .189048$$

$$\text{difference } \quad .004549$$

$1.6 \times .004549 \div 5 = .00151572$ which added to $.189048 = .190563 = \text{Area of segment with a diameter of } 1.$

$$\therefore .190563 \times 6^2 \times 16' = 109.764288 \text{ cub. ft.}$$

The above shows how to calculate the area when the height of segment \div diameter does not come out an exact number corresponding to those in table.

To further illustrate the above: The difference between the areas of the segments of a circle 1" in diameter .295 and .290 high respectively is .004549, that is to say for .005 or $\frac{1}{200}$ difference in height, a difference of .004549 in area, and as our quotient in the above example is not .005, but .0016 the exact difference is $\frac{1}{3}$ of .004549 $\times 1.6 = .00151606$, which, when added to the area of .290 which is .189048 = .190563 as the correct area of circle were 1" diameter.

GEO. WHITE-FRASER,

MEM. CAN. SOC. CIV. ENG.

MEM. AM. INST. ELEC. ENG.

DOMINION TOPOGRAPH: SURVEYOR.

**CONSULTING
ELECTRICAL
ENGINEER.**

Advice given on Management and Alteration or Extension of Electric and Steam Plants.

Tests of Engines, Motors or Dynamos, etc.

Specifications, Supervision or Plans for Central Stations, Isolated Plants, Water Powers, etc., Electric Railways and Electrical Transmission of Power.

Water Works Pumping Plants, etc.

OFFICES:

18 IMPERIAL LOAN BUILDING,

TORONTO, ONT.

The **CHEAPEST** and **MOST** "Perfection Sink"
CONVENIENT SINK is the

Buy your Plumbing
and
Steam Goods from**MALCOLM & CO.,**

89 and 91 Church Street.

Example III.—Circle 5' diameter, segment 1.105' high. Find area

$$1.105 \div 5 = .221 = \text{quotient}$$

$$\text{height } .225 = .132273$$

$$\text{height } .220 = \underline{.128114}$$

$$\text{difference} = .004159$$

$.004159 \div 5 = .000831$, which, added to $.128114 = .128945$, area for 1" diameter.

$\therefore .128945 \times 5^2 = 3.223625$ square feet, which is absolutely correct to the fourth figure in the decimals.

We shall prove Example 1 by calculating same in a different manner.

$AD = \text{chord} = 4'$ long, AC, CD , each $2.5'$ long.

Find Angle ACD —

$$AC : AB :: \sin. 90 : \sin. ACB$$

$$2.5 : 2 :: 1 : \frac{2}{2.5}$$

$$\sin. \frac{2}{2.5} = .8 = 53^\circ 8' \therefore ACD = 106^\circ 16'$$

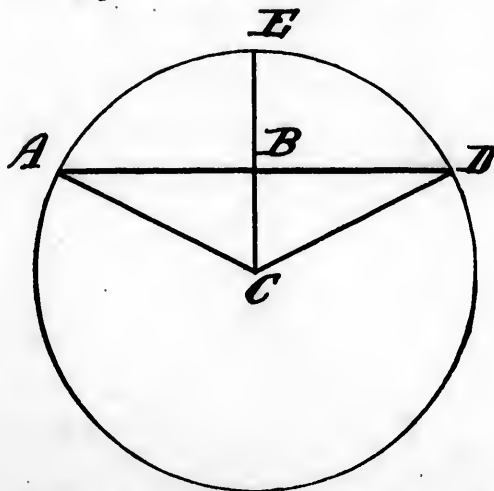

To Find the Area of a Sector when the Angle is given—

RULE: As 360° is to the degrees in the arc of the sector, so is the area of the whole circle to the area of the sector; or Multiply the arc of the sector by half the radius.

First Method— $360 : 106^\circ 16' :: 5^2 \times .7854 : \text{Area of sector} = 5.7956$ square feet.

From this has to be deducted the area of the triangle ACD to get the area of segment ADE .

$$CE = 2.5'; CB = CE - BE = 2.5 - 1 = 1.5'$$

$$\text{Area of triangle } ACD = 2 \times 1.5 = 3 \text{ square feet}$$

$$5.7956 - 3 = 2.7956 = \text{Area of sector } ADE.$$

WESTMAN & BAKER,

MANUFACTURERS OF

PRINTING PRESSES, PAPER CUTTERS,

And all classes of Machinery and
Supplies for Printers, Book-Binders,
and Paper Box Makers, Shafting,
Pulleys, Hangers, etc., and
General Repairs.

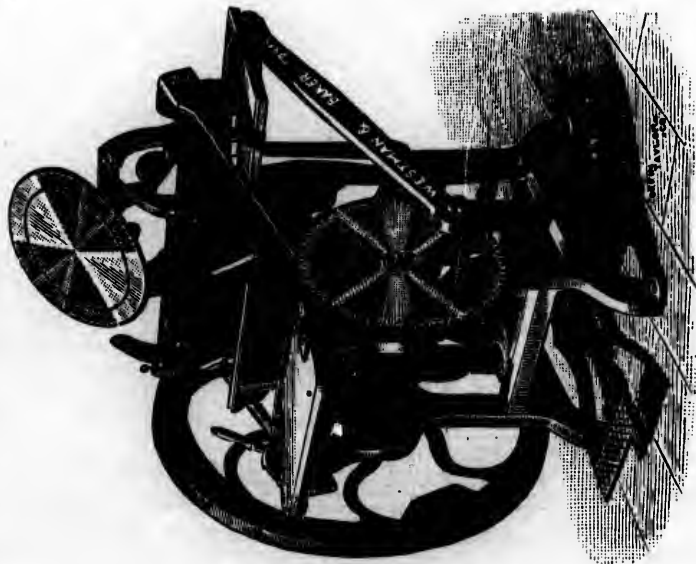

78

WELLINGTON ST. WEST.

TORONTO.

Another Example—Circle 5' diameter, segment 1.105' in height.
Find area.

$$\begin{aligned} 1.105 \div 5 &= .221 \\ \text{height, } .225 &= .132273 \\ \text{height, } .220 &= .128114 \\ \text{difference} &= .004159 \end{aligned}$$

$\therefore .004159 \div 5 = .000831$, which, when added to $.128114$, gives
 $.128945 = \text{Area for segment } .221 \text{ in height, } 1'' \text{ diameter.}$

$\therefore .128945 \times 5^2 = 3.223625$ square feet, which is correct to the
fourth place after decimal point.

To Find the Radius of a Circle when the Chord and Height of
the Arc are given—

RULE: Square half the chord, and divide by the height; then
add the height and divide by 2.

Example—Required the radius of a circle in which the chord is
24', and the height of the arc is 4'. Ans.—20 feet.

To Find the upright Surface of a Cone—

RULE: Multiply the perimeter of the base by the slant height
and divide by 2.

To Find the total Surface of a Cone—

RULE: Multiply the perimeter of the base by the slant height and
divide by 2, then add the area of the base.

Example I.—The radius of the base of a cone is 3' and the slant
height is 10'. Find the upright surface. Ans.—94.248 square feet.

Example II.—The diameter of the base of a cone is 25' and the
perpendicular height 40'. Find the total surface. Ans.—2136 sq. ft.

To Find the Surface of a Sphere—

RULE: Multiply the circumference by the diameter or square the
diameter and multiply by 3.1416.

Example—Find the surface of a sphere whose diameter is 12.5
yards. Ans.—490 $\frac{1}{2}$ square yards.

To Find the Surface of a Cylinder—

RULE: Multiply the length by the circumference and add the area
of the ends.

Example—What is the total surface of a cylinder 6' diameter and
13.5' high? Ans.—34.5576 square yards.

To Find the Surface of a Frustum of a Cone or Pyramid—

RULE: To the sum of the areas of both ends add the product of
of the sum of the perimeters of the ends by one-half the slant height.

To Find the upright surface, multiply the sum of the perimeters of
the ends by one-half the slant height.

Example—What is the upright surface of the frustum of a hex-
agonal pyramid, the length of the sides of the ends being 20' and 12'
and the slant height 10'. Ans.—960 square feet.

Find the total surface of the frustum of a cone, the circumfer-

PREMIER BREWERY OF CANADA.

Beyond Competition
are our English and
Bohemian

HOPPED ALES.

English and
Bohemian

"GOLD LABEL"
in bottles only.

XXX PORTER.
PILSENER,
IMPERIAL and
BOCK BEER.

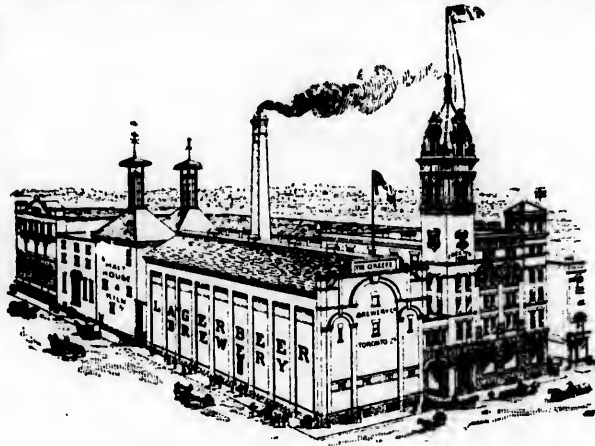

The **O'Keefe Brewery Co.,**
of TORONTO, Limited.

COPPER WORK FOR



Brewers, Distillers, Confectioners,
Varnish Makers, Steamboats, etc.

ENGINEERS' WORK OF ANY DESCRIPTION.

The **Booth Copper Co.,** of Toronto,
Limited,
TORONTO, ONT.

ences of whose ends are 20' and 12' and the slant height 8'. Ans.—171.29 square feet.

To Find the Surface of a Wedge—

RULE: Take the sum of all the separate surfaces.

SIMILAR SURFACES.

Circles and similar plain figures are to each other as the squares of their diameters or of their similar sides.

For Example—As the area of one circle is to the square of its diameter so is the area of another circle to the square of its diameter; and as the square of the diameter of a circle is to its area so is the square of the diameter of another circle to its area.

MENSURATION OF SOLIDS.

To Find the Solidity of a Sphere or Globe—

RULE: Cube the diameter and multiply by .5236.

Note—.5236 is one-sixth of 3.1416.

Example—Find the solidity of a sphere 2½' in diameter. Ans.—8 cubic feet, 313½ cubic inches.

To Find the Solidity of a Wedge—

RULE: Add the three parallel edges together, multiply the sum by the perpendicular breadth of the base and by one-sixth of the perpendicular height.

Example—The height of a wedge is 1½', the edge is 1¼', length of base 2¾', and the breadth 4½". Find the contents in cubic inches. Ans.—892½ cubic inches.

To Find the Solidity of the Frustum of a Cone or Pyramid—

RULE: Multiply the sum of the areas of the two ends and the mean proportional between these areas by the perpendicular height, and divide by 3.

Example—What is the solidity of the frustum of a hexagonal pyramid, the length of the sides of the ends being 20' and 12', and the slant height 10'. Ans.—4888.

To Find the Solidity of a Cube, a Parallelopipedon, a Prism or a Cylinder—

RULE: Multiply the area of the base by the height. For a cube the rule may be put thus: Cube the sides.

Example—A cistern is 15' long, 9' wide, and 2½' deep. How many gallons does it hold? (A gallon=277.274 cubic inches.) Ans.—2103½ gallons.

A boiler 4.5' diameter is 10.5' long. How many lbs. of water will fill it? (A gallon=10 lbs.) Ans.—10407.34 lbs.

To Find the Solidity of a Prismoid—

RULE: To the area of the top and bottom add four times the area of the middle section (or the product of the sums of the length and breadths of the top and bottom), and multiply the sum by one-sixth the height.

Note—The prismoid is a solid having parallel end areas, and

ESTABLISHED 1886.

TELEPHONE 2489.

Dominion Copper and Brass Works,

Manufacturers of Distillers', Brewers', Confectioners' and Marine

COPPER AND BRASS WORK,

Varnish Kettles, Dyers' Cylinders, Baths, Boilers,
Fire Extinguishers, Brass Railing, Metal Spinning,
Hose Couplings ¼" to 7", Branch Pipes and Brass
Castings.

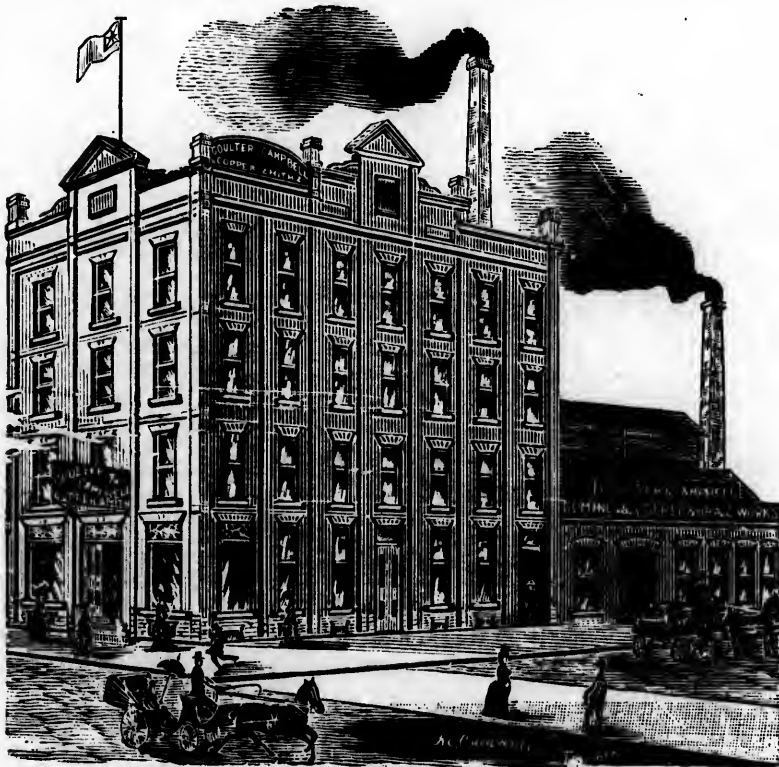

COULTER & CAMPBELL,

155 AND 157 GEORGE STREET,
AND 2 TO 12 BRITAIN STREET,

TORONTO.

may be composed of any combination of prisms, cylinders, wedges, pyramids or cones, or frustums of the same, whose bases and apices lie in the end areas.

Example—What is the content of a trough 6' long, 3' wide at the top, and 5' long and 2' wide at the bottom and 2' deep? Ans.— $27\frac{3}{4}$ cubic feet.

SIMILAR SOLIDS (*General Principle*).

Similar solids are to each other as the cubes of their diameters, sides, etc. For example—As the content of a globe is to the cube of its diameter, so is the content on another globe to the cube of its diameter; and as the cube of the diameter of a globe is to its content, so is the cube of the diameter of another globe to its content.

CUBIC OR SOLID MEASURE.

1728 cubic inches=1 cubic foot.

27 " feet=1 cubic yard.

277.274 cubic inches=1 gallon=10 lbs. of water.

AREAS OF SMALL CIRCLES.

Advancing by 32nds.

Diam.	Area.	Diam.	Area.	Diam.	Area.	Diam.	Area.
$\frac{1}{32}$.00076	$\frac{9}{32}$.0621	$\frac{17}{32}$.2216	$\frac{25}{32}$.4793
$\frac{1}{16}$.0030	$\frac{11}{16}$.0767	$\frac{19}{16}$.2485	$\frac{13}{8}$.5185
$\frac{3}{32}$.0069	$\frac{13}{16}$.0928	$\frac{19}{16}$.2768	$\frac{27}{32}$.5591
$\frac{1}{8}$.0122	$\frac{3}{8}$.1104	$\frac{5}{8}$.3068	$\frac{7}{8}$.6013
$\frac{5}{32}$.0192	$\frac{1}{2}$.1296	$\frac{3}{2}$.3382	$\frac{9}{8}$.6450
$\frac{3}{16}$.0276	$\frac{7}{16}$.1503	$\frac{11}{16}$.3712	$\frac{15}{8}$.6903
$\frac{7}{32}$.0376	$\frac{15}{16}$.1725	$\frac{3}{2}$.4057	$\frac{31}{8}$.7370
$\frac{1}{4}$.0490	$\frac{1}{2}$.1963	$\frac{3}{4}$.4417	1	.7854

AREAS OF CIRCLES,

Advancing by 8ths.

AREAS.

Diam.	0	$\frac{1}{8}$	$\frac{1}{4}$	$\frac{3}{8}$	$\frac{1}{2}$	$\frac{5}{8}$	$\frac{3}{4}$	$\frac{7}{8}$	Diam.
0	.0	.0122	.0490	.1104	.1963	.3068	.4417	.6013	0
1	.7854	.9940	.1227	1.484	1.767	2.073	2.405	2.761	1
2	3 1416	3.546	3.976	4.430	4 908	5.411	5.939	6.491	2
3	7.068	7.669	8.295	8.946	9.621	10.32	11.04	11.79	3
4	12.56	13.36	14.18	15.03	15.90	16.80	17.72	18 66	4
5	19.63	20 62	21.64	22.69	23.75	24.85	25.96	27.10	5

ROBB-ARMSTRONG AUTOMATIC ENGINES

*CENTRE OR SIDE CRANK.
SIZES UP TO 700 H.P.*

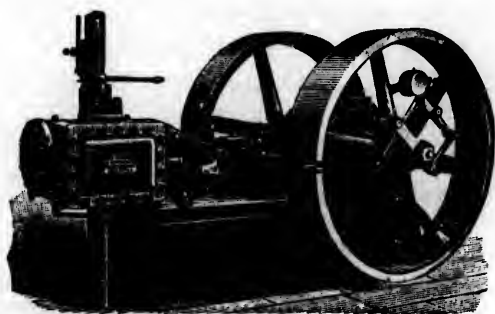

THE MONARCH ECONOMIC **BOILER**

IS PORTABLE.

*HAS AN OUTER CASING AND REQUIRES NO BRICKWORK.
LEAVES OUR SHOP MOUNTED ON SKIDS READY FOR USE.*

SAVES FUEL.

*SOME TESTS SHOW A SAVING OF 30 PER CENT. OVER A
COMMON BRICK SET BOILER. WE GUARANTEE AT LEAST
10 PER CENT.*



ROBB ENGINEERING Co.,

LIMITED,

AMHERST, N.S.

AREAS OF CIRCLES.—Continued.

Diam.	0	1/8	1/4	3/8	1/2	5/8	3/4	7/8	Diam.
6	28.27	29.46	30.67	31.91	33.18	34.47	35.78	37.12	6
7	38.48	39.87	41.28	42.71	44.17	45.66	47.17	48.70	7
8	50.26	51.84	53.45	55.08	56.74	58.42	60.13	61.86	8
9	63.61	65.39	67.20	69.02	70.88	72.75	74.66	76.58	9
10	78.54	80.51	82.51	84.54	86.59	88.66	90.76	92.88	10
11	95.03	97.20	99.40	101.6	103.8	106.1	108.4	110.7	11
12	113.0	115.4	117.8	120.2	122.7	125.1	127.6	130.1	12
13	132.7	135.2	137.8	140.5	143.1	145.8	148.4	151.2	13
14	153.9	156.6	159.4	162.2	165.1	167.9	170.8	173.7	14
15	176.7	179.6	182.6	185.6	188.6	191.7	194.8	197.9	15
16	201.0	204.2	207.3	210.5	213.8	217.0	220.3	223.6	16
17	226.9	230.3	233.7	237.1	240.5	243.9	247.4	250.9	17
18	254.4	258.0	261.5	265.1	268.8	272.4	276.1	279.8	18
19	283.5	287.2	291.0	294.8	298.6	302.4	306.3	310.2	19
20	314.1	318.1	322.0	326.0	330.0	334.1	338.1	342.2	20
21	346.3	350.4	354.6	358.8	363.0	367.2	371.5	375.8	21
22	380.1	384.4	388.8	393.2	397.6	402.0	406.4	410.9	22
23	415.4	420.0	424.5	429.1	433.7	438.3	443.0	447.6	23
24	452.3	457.1	461.8	466.6	471.4	476.2	481.1	485.9	24
25	490.8	495.7	500.7	505.7	510.7	515.7	520.7	525.8	25
26	530.9	536.0	541.1	546.3	551.5	556.7	562.0	567.2	26
27	572.5	577.8	583.2	588.5	593.9	599.3	604.8	610.2	27
28	615.7	621.2	626.7	632.3	637.9	643.5	649.1	654.8	28
29	660.5	666.2	671.9	677.7	683.4	689.2	695.1	700.9	29
30	706.8	712.7	718.6	724.6	730.6	736.6	742.6	748.6	30
31	754.8	760.9	767.0	773.1	779.3	785.5	791.7	798.0	31
32	804.2	810.5	816.9	823.2	829.6	836.0	842.4	848.8	32
33	855.3	861.8	868.3	874.8	881.4	888.0	894.6	901.3	33
34	907.9	914.6	921.3	928.1	934.8	941.6	948.4	955.3	34
35	962.1	969.0	975.9	982.8	989.8	996.8	1003.8	1010.8	35
36	1017.9	1025.0	1032.1	1039.2	1046.4	1053.5	1060.7	1068.0	36
37	1075.2	1082.5	1089.8	1097.1	1104.5	1111.8	1119.2	1126.7	37
38	1134.1	1141.6	1149.1	1156.6	1164.2	1171.7	1179.3	1186.9	38
39	1194.6	1202.3	1210.0	1217.7	1225.4	1233.2	1241.0	1248.8	39
40	1256.6	1264.5	1272.4	1280.3	1288.3	1296.2	1304.2	1312.2	40
41	1320.3	1328.3	1336.4	1344.5	1352.7	1360.8	1369.0	1377.2	41
42	1385.4	1393.7	1402.0	1410.3	1418.6	1427.0	1435.4	1443.8	42
43	1452.2	1460.7	1469.1	1477.6	1486.2	1494.7	1503.3	1511.9	43
44	1520.5	1529.2	1537.9	1546.6	1555.3	1564.0	1572.8	1581.6	44
45	1590.4	1599.3	1608.2	1617.0	1626.0	1634.9	1643.9	1652.9	45
46	1661.9	1671.0	1680.0	1689.1	1698.2	1707.4	1716.5	1725.7	46
47	1734.9	1744.2	1753.5	1762.7	1772.1	1781.4	1790.8	1800.1	47
48	1809.6	1819.0	1828.5	1837.9	1847.5	1857.0	1866.6	1876.1	48
49	1885.7	1895.4	1905.0	1914.7	1924.4	1934.2	1943.9	1953.7	49
50	1963.5	1973.3	1983.2	1993.1	2003.0	2012.9	2022.8	2032.8	50
51	2042.8	2052.9	2062.9	2073.0	2083.1	2093.2	2103.4	2113.5	51

MEYER BROS.,

Manufacturers of

Laundry Machinery,

Cylinder Washers,
Steam Mangles,
Extractors,
Shirt and Collar
Ironing
Machines,
Starching
Machines, etc.

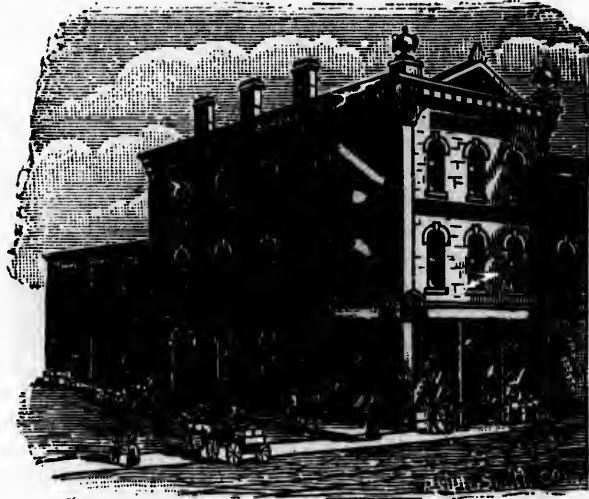

87 CHURCH ST.,

TORONTO.



TELEPHONE 2368.

GEO. W. GRANT & Co.,

GENERAL AGENTS,

43 WELLINGTON STREET EAST,

OILS, PACKINGS,
BOILER COMPOUND,
GENERAL ENGINEERS' SUPPLIES,
MACHINERY, ETC.

TORONTO.

AREAS OF CIRCLES.— *Continued.*

Diam.	0	1/8	1/4	3/8	1/2	5/8	3/4	7/8	Diam.
52	2123.7	2133.9	2144.2	2154.5	2164.8	2175.1	2185.4	2195.8	52
53	2206.2	2216.6	2227.1	2237.5	2248.0	2258.5	2269.1	2279.6	53
54	2290.2	2300.8	2311.5	2322.1	2332.8	2343.5	2354.3	2365.0	54
55	2375.8	2386.6	2397.5	2408.3	2419.2	2430.2	2441.1	2452.0	55
56	2463.0	2474.0	2485.1	2496.1	2507.2	2518.3	2529.4	2540.6	56
57	2551.8	2563.0	2574.2	2585.5	2596.7	2608.0	2619.4	2630.7	57
58	2642.1	2653.5	2664.9	2676.4	2687.8	2699.3	2710.9	2722.4	58
59	2734.0	2745.6	2757.2	2768.8	2780.5	2792.2	2803.9	2815.7	59
60	2827.4	2839.2	2851.1	2862.9	2874.8	2886.7	2898.6	2910.5	60
61	2922.5	2934.5	2946.5	2958.5	2970.6	2982.7	2994.8	3006.9	61
62	3019.1	3031.3	3043.5	3055.7	3068.0	3080.3	3092.6	3104.9	62
63	3117.3	3129.6	3142.0	3154.5	3166.9	3179.4	3191.9	3204.4	63
64	3217.0	3229.6	3242.2	3254.8	3267.5	3280.1	3292.8	3305.6	64
65	3318.3	3331.1	3343.9	3356.7	3369.6	3382.4	3395.3	3408.3	65
66	3421.2	3434.2	3447.2	3460.2	3473.2	3486.3	3499.4	3512.5	66
67	3525.7	3538.8	3552.0	3565.2	3578.5	3591.7	3605.0	3618.4	67
68	3631.7	3645.1	3658.4	3671.9	3685.3	3698.8	3712.2	3725.8	68
69	3739.3	3752.8	3766.4	3780.9	3793.7	3807.3	3821.0	3834.7	69
70	3848.5	3862.2	3876.0	3889.8	3903.6	3917.5	3931.4	3945.3	70
71	3959.2	3973.2	3987.1	4001.1	4015.2	4029.2	4043.3	4057.4	71
72	4071.5	4085.7	4099.8	4114.0	4128.3	4142.5	4156.8	4171.1	72
73	4185.5	4199.7	4214.1	4228.5	4242.9	4257.4	4271.8	4286.3	73
74	4300.9	4315.4	4330.0	4344.6	4359.2	4373.8	4388.5	4403.2	74
75	4417.9	4432.6	4447.4	4462.2	4477.0	4491.8	4506.7	4521.6	75
76	4536.5	4551.4	4566.4	4581.3	4596.4	4611.4	4626.4	4641.5	76
77	4656.6	4671.8	4686.9	4702.1	4717.3	4732.5	4747.8	4763.1	77
78	4778.4	4793.7	4809.1	4824.4	4839.8	4855.3	4870.7	4886.2	78
79	4901.7	4917.2	4932.8	4948.3	4963.9	4979.5	4995.2	5010.9	79
80	5026.6	5042.3	5058.0	5073.8	5089.6	5105.4	5121.2	5137.1	80

CIRCUMFERENCES OF CIRCLES,

Advancing by 8ths.

CIRCUMFERENCES.

Diam.	0	1/8	1/4	3/8	1/2	5/8	3/4	7/8	Diam.
0	.0	.3927	.7854	1.178	1.570	1.963	2.356	2.740	0
1	3.141	3.534	3.927	4.319	4.712	5.105	5.497	5.890	1
2	6.283	6.675	7.068	7.461	7.854	8.246	8.639	9.032	2
3	9.424	9.817	10.21	10.60	10.99	11.38	11.78	12.17	3
4	12.56	12.95	13.35	13.74	14.13	14.52	14.92	15.31	4
5	15.70	16.10	16.49	16.88	17.27	17.67	18.06	18.45	5

BEST QUALITY**COAL AND WOOD****LOWEST PRICES****OFFICES :**

20 King Street West. 409 Yonge Street.
 793 Yonge Street. 573 Queen Street West.
 1352 Queen Street West. 204 Wellesley Street.
 306 Queen Street East. 415 Spadina Ave.
 Esplanade Street, near Berkeley Street.
 Esplanade foot of West Market Street.
 Bathurst nearly opposite Front Street.
 Pape Ave. and G.T. R. Crossing.

THE ELIAS ROGERS Co.
LIMITED.

CIRCUMFERENCES.— *Continued.*

Diam.	0	$\frac{1}{8}$	$\frac{1}{4}$	$\frac{3}{8}$	$\frac{1}{2}$	$\frac{5}{8}$	$\frac{3}{4}$	$\frac{7}{8}$	Diam.
6	18.84	19.24	19.63	20.02	20.42	20.81	21.20	21.59	6
7	21.99	22.38	22.77	23.16	23.56	23.95	24.34	24.74	7
8	25.13	25.52	25.91	26.31	26.70	27.09	27.48	27.88	8
9	28.27	28.66	29.05	29.45	29.84	30.23	30.63	31.02	9
10	31.41	31.80	32.20	32.59	32.98	33.37	33.77	34.16	10
11	34.55	34.95	35.34	35.73	36.12	36.52	36.91	37.30	11
12	37.69	38.09	38.48	38.87	39.27	39.66	40.05	40.44	12
13	40.84	41.23	41.62	42.01	42.41	42.80	43.19	43.58	13
14	43.98	44.37	44.76	45.16	45.55	45.94	46.33	46.73	14
15	47.12	47.51	47.90	48.30	48.69	49.08	49.48	49.87	15
16	50.26	50.65	51.05	51.44	51.83	52.22	52.62	53.01	16
17	53.40	53.79	54.19	54.58	54.97	55.37	55.76	56.15	17
18	56.54	56.94	57.33	57.72	58.11	58.51	58.90	59.29	18
19	59.69	60.08	60.47	60.86	61.26	61.65	62.04	62.43	19
20	62.83	63.22	63.61	64.01	64.40	64.79	65.18	65.58	20
21	65.97	66.36	66.75	67.15	67.54	67.93	68.32	68.72	21
22	69.11	69.50	69.90	70.29	70.68	71.07	71.47	71.86	22
23	72.25	72.64	73.04	73.43	73.82	74.22	74.61	75.00	23
24	75.39	75.79	76.18	76.57	76.96	77.36	77.75	78.14	24
25	78.54	78.93	79.32	79.71	80.10	80.50	80.89	81.28	25
26	81.68	82.07	82.46	82.85	83.25	83.64	84.03	84.43	26
27	84.82	85.21	85.60	86.00	86.39	86.78	87.17	87.57	27
28	87.96	88.35	88.75	89.14	89.53	89.92	90.32	90.71	28
29	91.10	91.49	91.89	92.28	92.67	93.06	93.46	93.85	29
30	94.24	94.64	95.03	95.42	95.81	96.21	96.60	96.99	30
31	97.4	97.8	98.2	98.6	99.0	99.4	99.7	100.1	31
32	100.5	100.9	101.3	101.7	102.1	102.5	102.9	103.3	32
33	103.7	104.1	104.5	104.9	105.2	105.6	106.0	106.4	33
34	106.8	107.2	107.6	108.0	108.4	108.8	109.2	109.6	34
35	110.0	110.3	110.7	111.1	111.5	111.9	112.3	112.7	35
36	113.1	113.5	113.9	114.3	114.7	115.1	115.5	115.8	36
37	116.2	116.6	117.0	117.4	117.8	118.2	118.6	119.0	37
38	119.4	119.8	120.2	120.6	121.0	121.3	121.7	122.1	38
39	122.5	122.9	123.3	123.7	124.1	124.5	124.9	125.3	39
40	125.7	126.1	126.4	126.8	127.2	127.6	128.0	128.4	40
41	128.8	129.2	129.6	130.0	130.4	130.8	131.2	131.6	41
42	131.9	132.3	132.7	133.1	133.5	133.9	134.3	134.7	42
43	135.1	135.5	135.9	136.3	136.7	137.1	137.4	137.8	43
44	138.2	138.6	139.0	139.4	139.8	140.2	140.6	141.0	44
45	141.4	141.8	142.2	142.6	142.9	143.3	143.7	144.1	45
46	144.5	144.9	145.3	145.7	146.1	146.5	146.9	147.3	46
47	147.7	148.0	148.4	148.8	149.2	149.6	150.0	150.4	47
48	150.8	151.2	151.6	152.0	152.4	152.8	153.2	153.5	48
49	153.9	154.3	154.7	155.1	155.5	155.9	156.3	156.7	49
50	157.1	157.5	157.9	158.3	158.7	159.0	159.4	159.8	50
51	160.2	160.6	161.0	161.4	161.8	162.2	162.6	163.0	51

The
Wm. Sutton Compound Co.
 of Toronto, Limited.



Office :
 206 Queen St. East.

Telephone 2239.



SAFE, SURE AND RELIABLE.

The Trade Mark is Registered for the Protection
 of our Customers.



NEVER FAILS WHEN HONESTLY TRIED.



Imitation is the Very Best Proof of Excellence.

CIRCUMFERENCES.—Continued.

Diam.	0	$\frac{1}{8}$	$\frac{1}{4}$	$\frac{3}{8}$	$\frac{1}{2}$	$\frac{5}{8}$	$\frac{3}{4}$	$\frac{7}{8}$	Diam.
52	163.4	163.8	164.1	164.5	164.9	165.3	165.7	166.1	52
53	166.5	166.9	167.3	167.7	168.1	168.5	168.9	169.3	53
54	169.6	170.0	170.4	170.8	171.2	171.6	172.0	172.4	54
55	172.8	173.2	173.6	174.0	174.4	174.8	175.1	175.5	55
56	175.9	176.3	176.7	177.1	177.5	177.9	178.3	178.7	56
57	179.1	179.5	179.9	180.2	180.6	181.0	181.4	181.8	57
58	182.2	182.6	183.0	183.4	183.8	184.2	184.6	185.0	58
59	185.4	185.7	186.1	186.5	186.9	187.3	187.7	188.1	59
60	188.5	188.9	189.3	189.7	190.1	190.5	190.9	191.2	60
61	191.6	192.0	192.4	192.8	193.2	193.6	194.0	194.4	61
62	194.8	195.2	195.6	196.0	196.4	196.7	197.1	197.5	62
63	197.9	198.3	198.7	199.1	199.5	199.9	200.3	200.7	63
64	201.1	201.5	201.8	202.2	202.6	203.0	203.4	203.8	64
65	204.2	204.6	205.0	205.4	205.8	206.2	206.6	207.0	65
66	207.3	207.7	208.1	208.5	208.9	209.3	209.7	210.1	66
67	210.5	210.9	211.3	211.7	212.1	212.5	212.8	213.2	67
68	213.6	214.0	214.4	214.8	215.2	215.6	216.0	216.4	68
69	216.8	217.2	217.6	217.9	218.3	218.7	219.1	219.5	69
70	219.9	220.3	220.7	221.1	221.5	221.9	222.3	222.7	70
71	223.1	223.4	223.8	224.2	224.6	225.0	225.4	225.8	71
72	226.2	226.6	227.0	227.4	227.8	228.2	228.6	228.9	72
73	229.3	229.7	230.1	230.5	230.9	231.3	231.7	232.1	73
74	232.5	232.9	233.3	233.7	234.0	234.4	234.8	235.2	74
75	235.6	236.0	236.4	236.8	237.2	237.6	238.0	238.4	75
76	238.8	239.2	239.5	239.9	240.3	240.7	241.1	241.5	76
77	241.9	242.3	242.7	243.1	243.5	243.9	244.3	244.7	77
78	245.0	245.4	245.8	246.2	246.6	247.0	247.4	247.8	78
79	248.2	248.6	249.0	249.4	249.8	250.1	250.5	250.9	79
80	251.3	251.7	252.0	252.5	252.9	253.3	253.7	254.1	80

FOAMING IN BOILERS.

The causes are (1) dirty water, (2) trying to evaporate more water than the size and construction of the boiler is intended for, (3) taking steam too low down, (4) insufficient steam room, (5) imperfect construction of boiler, (6) too small a steam pipe, (7) and sometimes by carrying the water line too high.

Too little attention is paid to boilers with regard to their evaporative power. Where the boiler is large enough for the water to circulate, and there is enough surface to give off steam, foaming never occurs.

As the particles of the steam have to escape to the surface of the water in the boiler, unless that is in proportion to the amount of steam to be generated, it will be delivered with such violence that the water will be mixed with it, and cause foaming.

MICA BOILER

COVERINGS.

All Steam Users should see the NEW MICA BOILER and PIPE COVERING. It is Flexible, Durable and a Magnificent Non-Conductor of Heat.

Tested by Mechanical Experts of the Canadian Pacific Ry. Co., Grand Trunk Ry. Co., Michigan Central Ry. Co., Boiler Inspection and Insurance Co., and proved to be the BEST OF ALL NON-CONDUCTORS.

Full Particulars, Reports of Trials, Prices, Testimonials, etc., from

MICA BOILER
COVERING Co.,
LIMITED,

MONTREAL.
WINNIPEG.

9 JORDAN STREET,
TORONTO, ONT.

For violent ebullition, a plate hung over the hole when the steam enters the dome from the boiler is a good thing and prevents a rush of water by breaking it, when the throttle is opened suddenly.

In cases of very violent foaming it is imperative to check the draft and cover fires.

The steam pipe may be carried through the flange six inches into the dome, which will prevent the water entering the pipes by following the sides of the dome as it does.

A case of priming was stopped by removing some of the tubes under the smoke stack in the U. S. Steamer Galina, and substituting bolts.

Clean water, plenty of surface, plenty of steam room, large steam pipes, boilers large enough to generate steam without forcing the fires, are all that is required to prevent foaming.

PIPE COVERING.

With reference to the economy and cost of non-conducting material, it may be said that the material which is in the greatest degree non-conducting, incombustible and durable, will prove the most economical, even though its first cost be greater than that of an inferior article. Experiments with naked pipes show that 2' pipe carrying steam at 60 lbs. pressure will condense 180 grammes per foot per hour. Covered with the best non-conducting covering the condensation will be 36 grammes per foot per hour, a saving of 144 grammes per foot per hour, which is equivalent to 3 lbs. of water per day of 10 hours for each foot of pipe covered. The covering of 100' of pipe will then save, in a year of 300 ten-hour days, the coal necessary to convert 90,000 lbs. of water into steam. One pound of bituminous coal is capable of converting about 8.5 lbs. of water into steam, so that the saving in coal due to 100 feet of covering would be 10,588 lbs. of coal, which at \$4.00 per ton amounts to \$21.16. The real saving would probably be more than this. It may be stated in round terms that 100' of covering causes each year a saving in fuel of its own first cost. Inasmuch as the best non-conducting covering pays for itself in one year, and will last indefinitely under ordinary circumstances, its efficiency is beyond question.

From tests made by the Canadian Pacific Railway Company in 1896, of the comparative value of some of the best-known coverings, it appeared that the amount of heat lost by radiation through the different substances tested were as follows :

	Mean temperature during 5th hour.	Difference between tank and atmosphere.	Loss in 5th hour.	Loss in 5th hour per degree of difference of temperature
Bare Tank.....	133½	55½	11	.198
Asbestos composition	163½	85½	9	.105
Magnesia Blocks	181¾	103¾	7	.0674
Wood lagging and air space	181¾	103¾	7	.0674
Asbestos and Wood.....	185	107	6	.056
Mica	194½	116½	5	.0428

Eureka Mineral Wool & Asbestos Co.

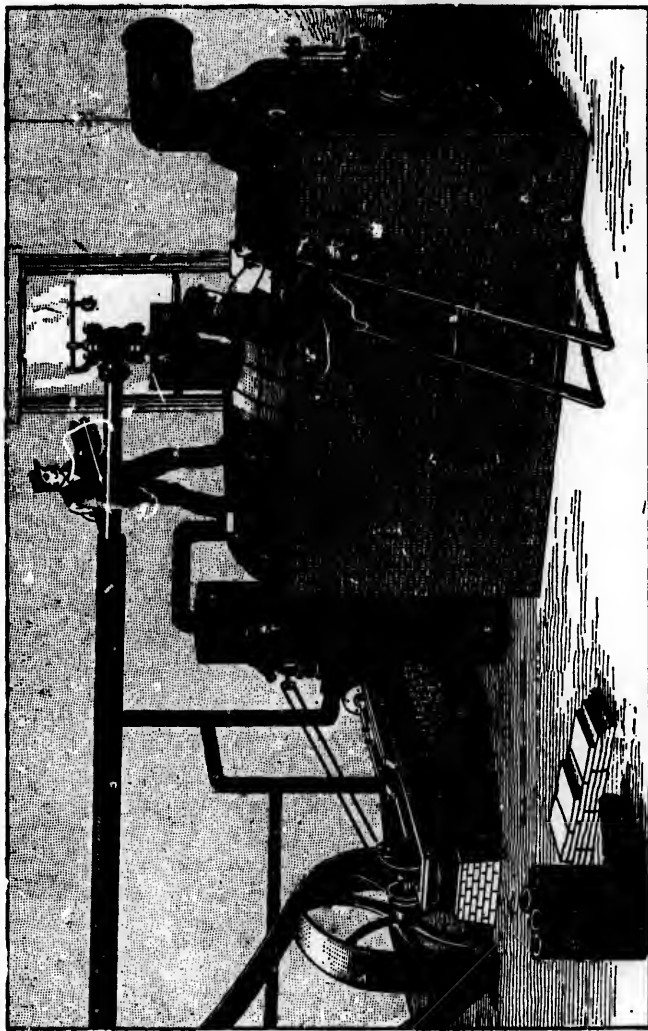

Our
Sectional Pipe
and Boiler
Covering
Prevents
Radiation,
Condensation,
Loss of Power
and
Waste of Fuel,
and is easily
applied.

Our Lines
are
Sectional
Coverings,
Asbestos
Goods,
Asbestos
Cement,
Mineral
Wool and
Engine
Packings.

114 BAY STREET,

TORONTO, ONT.

The loss of heat by radiation from naked pipes is very considerable, and in case of long pipes, becomes serious, not only on account of the waste of fuel, but because the condensed water interferes very badly with the working of the engine.

The exposed surfaces of boilers should also be protected from radiation by some efficient material. Many substances having widely different values as a protection from radiation have been used. Hair felt is the most effective jacketing known, but it has the disadvantage of soon rotting when exposed to heat. The following table shows the relative amounts of heat radiated from felt jacketing of different thicknesses, the radiating power of a rough cast iron surface being taken as 100:

0".35 of felt, heat radiated	32.19
0".5 " " "	22.4
1" " " "	11.2
1".5 " " "	5.7
2" " " "	4.5
2".5 " " "	3.5
3" " " "	2.6

These figures point to the fact that little is to be gained by increasing the thickness of the felt over two (2) inches. The following table, by Chas. E. Emery, Ph. D., gives the relative non-conductivity of various materials :

MATERIAL.	VALUE.	MATERIAL.	VALUE.
Hair Felt	100	Loam	55
Mineral Wool, No. 2	83.2	Slaked Lime..	48
do. with Tar	71.5	Gas House Carbon	47
Sawdust	68	Asbestos.....	36.3
Mineral Wool, No. 1.....	67.6	Coal Ashes	34.5
Charcoal	63.2	Coke, in lumps	27.7
Pine Wood, across grain ..	55.3	Air space 2 inches deep.....	13.6

"Mineral Wool" is a good protection, and is incombustible. It is a fibrous material made from slag. Ashes and loam should not be used on account of their tendency to absorb moisture, and because they hasten corrosion when leakage occurs. A cheap and effective protection is obtained by plastering the surface with a layer, 2 inches thick, of mortar composed of one-third plaster of paris by volume and two-thirds sawdust, over which a covering of hair felt or mineral wool, an inch thick, is fastened with wire, the whole being enclosed in roofing paper secured in the same way. A French method employs a paste of flour mixed with sawdust until a moderately thick dough is formed. Four or five layers are applied, each one-fourth inch thick. Iron surfaces should be well cleaned from grease before application. While copper should be washed with a hot solution of clay in water. A coating of tar renders the mixture weather-proof. Besides these, there are many patent coverings composed of mica, asbestos, magnesia, etc., all of which have their merits.

USE

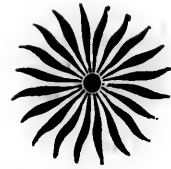

LUXFER

PRISMS

and obtain Daylight.

Engineers know the advantage of having daylight to
work by in

**BASEMENTS,
ENGINE ROOMS AND
WORKSHOPS.**

By using Luxfer Prisms daylight can be carried into
imperfectly lighted rooms of any description.

ESTIMATES GIVEN.

Luxfer Prism Company, Limited,
58 Yonge Street, TORONTO.

USEFUL INFORMATION.

The height of a column of fresh water, equal to a pressure of 1 lb. per square inch, is 2.31 feet. A column of water 1 foot high exerts a pressure of .433 lbs. per square inch. The capacity of a cylinder in gallons is equal to the length in inches multiplied by the area in inches, divided by the cubical contents of one gallon in inches (see following table). The velocity in feet per minute, necessary to discharge a given volume of water in a given time, is found by multiplying the number of cubic feet of water by 144 and dividing the product by the area of the pipe in inches. The area of a required pipe, the volume and velocity being given, is found by multiplying the number of cubic feet of water by 144 and dividing the product by the velocity in feet per minute. The area being found, the diameter is obtained by the Table of Areas. Doubling the diameter of the pipe increases its capacity four times. The friction of liquids in pipes increases as the square of the velocity. The horse-power necessary to elevate water to a given height is found by multiplying the weight of the water elevated per minute, in pounds, by the height in feet and dividing the product by 33,000. An allowance of 25 per cent. should be made for friction, etc.

WEIGHT AND CAPACITY OF DIFFERENT STANDARD GALLONS OF WATER.

	Cubic Inches in a Gallon.	Weight of a Gallon in lbs.	Gallons in a cubic foot.	Weight of a cubic foot of water, English standard, 62.321 pounds Avoirdupois.
Imperial or English.....	277.274	10.00	6.232102	
United States	231	8.33111	7.480519	

A cubic inch of water, evaporated under ordinary atmospheric pressure will be converted into approximately 1 cubic foot of steam, and it exerts a mechanical force equal to lifting 2,120 lbs. 1' high; 27,222 cubic feet of steam weigh 1 lb., 13,817 cubic feet of air weigh 1 lb., the specific gravity of steam, at atmospheric pressure being .441 that of air at 34° F., and .0006 that of water at the same temperature.

The government method prescribed for cleaning brass, and in use at all the United States arsenals, is said to be the best in the world. The plan is to make a mixture of two parts nitric and one part sulphuric acid in a stone jar, having also a pail of fresh water and a box of sawdust. The articles to be treated are first dipped into the acid, then placed in the water, and finally rubbed with the sawdust. This immediately changes them to a brilliant color. If the brass is greasy, it is first dipped into a strong solution of potash or soda in warm water, and then rinsed. This dissolves the grease and leaves the acid free to act.

In backing out bolts, without protection for the thread, strike the hardest blows possible with a heavy hammer. Light blows with a light hammer only upset the bolt.

Why not Get The Best ?

*If you are paying more for LEATHER BELTING
than we charge, you are paying too much.*

*If you are paying less than we sell at
you are not obtaining as good a quality.*

SADLER & HAWORTH.

FACTORIES AT

511-513-515 WILLIAM ST MONTREAL.

9 & 11 JORDAN ST. TORONTO.

BELTING.

Although there is not nearly as much known in general about the power of transmitting agencies as there should be, still it seems that almost any other method or means is better understood than belts. One of the chief difficulties in the way of a better knowledge of the belting problem, is the relations that belts and pulleys bear to each other. The general supposition, and one that leads to many errors, is that the larger in diameter a pulley is, the greater its holding capacity—the belt will not slip so easily, is the belief. But it is merely a belief, and has nothing to sustain it unless it be faith, and faith without work is an uncertain factor. I would like here to impress upon the minds of all interested the following immutable principles or laws :

1. *The adhesion of the belt to the pulley is the same, the arc or number of degrees of contact, aggregate tension or weight being the same, without reference to width of belt or diameter of pulley.*

2. *A belt will slip just as readily on a pulley 4' in diameter as it will on a pulley 2' in diameter, provided the conditions of the faces of the pulleys, the arc of contact, the tension and the number of feet the belts travel per minute are the same in both cases.*

3. *A belt of a given width, and making 2,000 or any other given number of feet per minute, will transmit as much power running on pulleys, 4' in diameter, provided the arc of contact, tension and conditions of pulley faces all be the same in both cases.*

It must be remembered, in reference to the first rule, that when speaking of tension, that aggregate tension is never meant unless so specified. A belt 6" wide, with the same tension, or as taut as a belt 1" wide, would have 6 times the aggregate tension of the 1" belt. Or it would take 6 times the force to slip the 6" belt as it would the 1". I prefer to make the readers of this, practical students. I want them to learn for themselves. Information obtained in that way is far more valuable, and liable to last much longer. In order that the reader may more fully understand whether or not a large pulley will hold better than a small one; let him provide a short, stout shaft, say 3 or 4' long and 2" in diameter. To this shaft firmly fasten a pulley, say 12" in diameter, or any other size small pulley that may be convenient. The shaft must be then raised a few feet from the floor and firmly fastened, either in vices or by some other means, so that it will not turn. It would be better, of course, to have a smooth-faced iron pulley, as such are most generally used. So far as the experiment is concerned, it would make no difference what kind of a pulley was used, provided all the pulleys experimented with be of the same kind, and have the same kind of face finish. When the shaft and pulleys are fixed in place, procure a new leather belt and throw it over the pulley. To one end of the belt attach a weight, equal say to 40 lbs.—or heavier, if desired—for each inch in width of belt used; let the weight rest on the floor. To the other end of the belt attach another weight, and keep adding to it until the belt slips and raises the first weight from the floor. After the experimenter is satisfied with playing with the 12" pulley, he can take it off the shaft and put on a 24", a 36", or any other size he may wish, or, what is

All the Latest
Novelties in

**High-Class Suitings,
Overcoats, etc.,**

Are always in stock and ready for your inspection.
Perfect Fit, Best of Material and Workmanship.
Lowest possible prices.

G. Hawley Walker,

126 and 128

THE YONGE STREET
TAILOR.

SMOKE 

Board of Trade

5c. Cigars and

Royal Crown

10c. Cigars.

MANUFACTURED BY

SPILLING BROS.,

137 JARVIS STREET.

better, he can have all on the same shaft at the same time. The belt can then be thrown over the large pulley, and the experiment repeated. It will then be found, if pulley faces are alike, that the weight which slipped the belt on the small pulley will also slip it on the large one. The method shows the adhesion of a belt with 180° contact, but as the contact varies greatly in practice, it is well enough to understand what may be accomplished with other arcs of contact. But, after all, many are probably at a loss how to account for some observations previously made. They have noticed that when a belt at actual work slipped, an increase in the size (diameter) of the pulleys always remedied the difficulty and prevented the slipping. A belt has been known to refuse to do the work allotted to it, and continue to slip over pulleys 2' in diameter, but from the moment the pulleys were changed to 3' in diameter there was no further trouble. These observed facts seem to be at variance with and to contradict the results of the experiments that have been made. All, however, may rest assured that it is only apparent, not real. The resistance to slippage is simply a unit of useful effect, or that which can be converted into useful effect. The magnitude of the unit is in proportion to the tension of the belt. The sum total of useful effect depends upon the number of times the unit is multiplied. A belt 6" wide and having a tension equal to 40 lbs. per inch in width, and travelling at the rate of 1' per minute, will raise a weight of 240 lbs. 1' high per minute. If the speed of the belt be increased to 136.5' per minute, it will raise a weight of 33,000 lbs. per minute, or be transmitting 1-horse power. The unit of power transmitted by a belt is rather more than its tension, but to take it at its measured tension is at all times safe, and 40 to 45 lbs. of a continuous working strain is as much, perhaps, as a single belt should be subjected to. A little reflection will now convince the reader that a belt transmits power in proportion to its lineal speed, without reference to the diameter of the pulleys. Having arrived at that conclusion, it is then easy to understand why it is that a belt working over a 36" pulley will do its work easy, when it refused to do it and slipped on 24" pulleys. If the belt travelled 800' per minute on the 24" pulleys, on the 36" pulleys it would travel 1,200', thus giving it one-half more transmitting power; if in the first instance it was able to transmit but 8 horse power, in the second instance it will transmit 12-horse power. All of which is due to the increase in the speed of the belt and not to the increase in the size of the pulleys; because, as has been shown, the co-efficient of friction or resistance to slippage, is the same on all pulleys with the same arc of belt contact. There is no occasion for elaborate and perplexing formulas and intricate rules. They serve no useful purpose, but tend only to mystify and puzzle the brain of all who are not familiar with the higher branches of mathematics; and it is the fewest number of our every-day practical mechanics who are so familiar. In all, or nearly all treatises on belting, the writer will tell you that at 600, 800 or 1000' per minute, as the case may be, a belt 1" wide will transmit 1-horse power; and yet when we come to apply their rules to practice, no such results can be obtained one time in ten. The rules are just as liable to make the belt travel 400, 1000 or 1600 per minute per horse power, as the number of feet they may give as indicating a horse power. I have adopted, and all my calculations are based upon

the assumption that a belt travelling 800' per minute, and running over pulleys both of which are the same diameters, will easily transmit 1-horse power for each inch in width of belt. A belt under such circumstances would have 180° of contact on both pulleys without the interposition of idlers or tighteners. The last proposition being accepted as true, and the basis correct, the whole matter resolves itself into a very simple problem, so far as a belt with 180° contact is concerned. It is simply this: If a belt travelling 800' per minute transmit one-horse power at 1,600', it will transmit two horse power, or, if 2,400', three-horse power, and so on. It is no trouble for anyone to understand that, if he understands simple multiplication or division. It is not, however, always the case that both pulleys are the same size; and as soon as the relative sizes of the pulleys change, the transmitting power of the belt changes, and that is the reason why no general rule has ever or ever will be made for ascertaining the transmitting capacity of belts under all circumstances. When the pulleys differ in size, the larger of the two is lost sight of—it no longer figures in the calculations—the small pulley only must be considered. To get at it, the number of degrees of belt contact on the small pulley must be ascertained as nearly as possible, and used for a guide for getting at the transmitting power, the next established basis below. Of course the experimenter can make a rule for every degree of variation; but it would require a great many, and is not necessary. I use five divisions, as follows:

For 180° useful effect	1.00
“ 157½°	“92
“ 135°	“84
“ 112½°	“76
“ 90°	“64

The experimenters may find that my figures are under-obtained results, which is exactly what they are intended to be, more especially at the 90° basis. I wish to make ample allowance. To ascertain the power a belt will transmit under the first-named conditions, divide the speed of the belt in feet per minute by 800, multiply by its width in inches and by 100. For the second, divide by 800, multiply by width in inches and by .92. Third place, divide by 800, multiply by width in inches and by .84. Fourth place, divide by 800, multiply by width in inches and by .76. Fifth place, divide by 800, multiply by width in inches and by .64. As an example: What would be the transmitting power of a 16" belt, travelling 2,500' per minute by each of the above rules?

- 1st. $2500 \div 800 = 3.125 \times 16$ and $100 = 50$ h. p.
- 2nd. $2500 \div 800 = 3.125 \times 16$ and $.92 = 46$ h. p.
- 3rd. $2500 \div 800 = 3.125 \times 16$ and $.84 = 42$ h. p.
- 4th. $2500 \div 800 = 3.125 \times 16$ and $.76 = 38$ h. p.
- 5th. $2500 \div 800 = 3.125 \times 16$ and $.64 = 32$ h. p.

As I have said, if the degrees of contact come between the divisions named above, in order to be on the safe side calculate from the first rule below it, or make an approximate, as they like. If the above lesson is studied well and strictly used, there can be no excuse for any mechanic putting in a belt too small for the work it has to do, provided he knows how much there is to do, which he ought, somewhere near at least.

STEAM.

Sensible and Latent Heat. Heat given to a substance, and warming it, is said to be *sensible* in the substance. Heat given to a substance and *not* warming it is said to become *latent*.—*Sir Wm. Thomson.*

Latent Heat is the quantity of heat which must be communicated to unit mass of a body in a given state, in order to convert it into another state without changing its temperature.—*Maxwell.*

If 1 lb. of ice be placed where it will receive heat uniformly at the rate of 18 units per minute it will melt gradually so that more and more of it becomes water until at the end of 8 minutes it is all melted; during this time the temperature of the ice and water will have remained at 32°. This shows that 144 units of heat have been spent without increasing the *sensible* heat of the substance; these 144 heat units have become latent in the water and this is the amount that must be taken from 1 lb. of water at 32° to change it to ice at 32°.

If the heat is still kept on the 1 lb. of water at 32°, it will in 10 minutes receive $10 \times 18 = 180$ units, which will raise its temperature to 212° when it will boil. It will continue to boil and become gradually converted into steam until in 53.7 minutes the whole is so changed. During this change its temperature will remain steadily at 212° and therefore $53.7 \times 18 = 966.6$ units will have become latent in steam.

Latent Heat of Fusion. When a body passes from the solid to the liquid state, its temperature remains nearly stationary, at a certain melting point during the operation of melting; and in order to make that operation go on, a quantity of heat must be transferred to the substance melted. This quantity is called the *latent heat of fusion*. In ice this is 144 units.

Latent Heat of Evaporation. When a body passes from the solid or liquid to the gaseous state, its temperature during the operation remains stationary at a certain boiling point, depending on the pressure of the vapor produced, and in order to make the evaporation go on, a quantity of heat must be transferred to the substance evaporated. This heat does not raise the temperature, but disappears in causing it to assume the gaseous state, and is called the *latent heat of Evaporation*.

Total Heat of Evaporation is the sum of the sensible and latent heats of evaporation. To raise 1 lb. of water from freezing point (32°F.) to the temperature of evaporation (32°F.) takes 180° sensible heat units and the additional heat required to evaporate it is called the latent heat; to evaporate 1 lb. water at 212° into steam at the same temperature takes 966.6 heat units. The total heat of evaporation for water is therefore $= 180 + 966.6 = 1146.6$.

If steam is generated at a higher temperature than 212°F., the sensible heat increases, and the latent heat decreases.

To find the latent heat of steam for any temperature, the following formula will be found very nearly correct :

$$\text{Latent heat} = 966.6 - .7(t - 212^\circ)$$

where t = the temperature of evaporation.

From this we see that since the temperature of the steam is raised, the latent heat diminishes only .7 of the increase in the sensible heat, it is therefore obvious that the *total heat increases*. For all temperatures above 212° the latent heat is less than 966.6, and for all temperatures below 212° the latent heat is greater than 966.6.

Example—What is the latent heat of steam when the thermometer registers 332°F .? Ans.— 882° .

When the latent heat is found, at any temperature, the total heat of evaporation is very easily determined.

$$\begin{aligned}\text{Total heat of steam} &= \text{Sensible} + \text{Latent heat} \\ &= (t - 32^{\circ}) + 966.6 - .7(t - 212^{\circ}) \\ &= 1083 + .3t\end{aligned}$$

Example—Find the total heat of steam at 212°F . Ans.—1146.6.

QUANTITY OF WATER REQUIRED FOR CONDENSATION.

Let H = total heat calculated from 32°F .
 t_1 = temperature of steam
 t_2 = temperature of water
 t_3 = resulting temperature
 X = lbs. of water at t_2

The loss of heat from the Steam = the gain of heat by the water.

The heat given up by 1 lb. of steam = $H - (t_3 - 32)$

The heat gained by X lbs. water = $X(t_3 - t_2)$

$$\therefore H - (t_3 - 32) = X(t_3 - t_2)$$

$$\text{But } H = 1083 + .3t_1$$

$$\therefore 1083 + .3t_1 - (t_3 - 32) = X(t_3 - t_2)$$

$$X = \frac{1115 + .3t_1 - t_3}{t_3 - t_2}$$

Example I.—If 1 lb. of steam at 212°F . be mixed with X lbs. of water at 60°F . What is the value of X when the resulting temperature is 100°F .? Ans.—26.96 lbs.

Example II.—Steam enters the condenser at a temperature of 142°F . to be condensed into water at 120°F .; the circulating water enters at 60°F . and is discharged at 100°F . find how many lbs. of circulating water will be required per lb. of steam. Ans.—25.9 lbs.

TABLE I.
Properties of Saturated Steam from 32° to 212°.

Temper- ature.	PRESSURE.		Temper- ature.	PRESSURE.	
	Inches of Mercury.	Lbs. per Sq. Inch Absolute.		Inches of Mercury.	Lbs. per Sq. Inch Absolute.
32	.181	.089	125	3.933	1.932
35	.204	.100	130	4.509	2.215
40	.248	.122	135	5.174	2.542
45	.299	.147	140	5.860	2.879
50	.362	.178	145	6.662	3.273
55	.426	.214	150	7.548	3.708
60	.517	.254	155	8.535	4.193
65	.619	.304	160	9.630	4.731
70	.733	.360	165	10.843	5.327
75	.869	.427	170	12.183	5.985
80	1.024	.503	175	13.654	6.708
85	1.205	.592	180	15.291	7.511
90	1.410	.693	185	17.044	8.375
95	1.647	.809	190	19.001	9.335
100	1.917	.942	195	21.139	10.385
105	2.229	1.095	200	23.461	11.526
110	2.579	1.267	205	25.994	12.770
115	2.976	1.462	210	28.753	14.126
120	3.430	1.685	212	29.922	14.700

A strip of looking-glass held behind a glass water gauge makes it easier to see the water line.

In cutting rubber for gaskets wet the knife often with a strong solution of potash. This makes the cutting easier.

In making rubber joints, chalk the rubber well before screwing up the flanges. When this is done the joint will always come apart easily.

To ascertain whether a plate is burned or crystallized, take a thin, sharp chisel and cut a thin chip for an inch or two; if the plate is good the chip will curl up.

The calorific power of wood is about .4 that of the same weight of good coal. The fuel value of different woods is practically the same, provided they are equally dry.

A good quick setting rust joint is formed of sal-ammoniac powdered, 1 lb.; flour of sulphur, 2 lbs.; iron borings, 80 lbs.; mix to a paste with water. A slow setting rust joint is made up of sal-ammoniac, 2 lbs.; sulphur, 1 lb.; iron borings, 200 lbs. This is best, if the joint is not needed for use at once.

TABLE II.
 PROPERTIES OF SATURATED STEAM.
 (From Peabody's Tables).

Press. in lbs. per sq. in. ab've vacu'm	Temperature in degrees Fah.	Total heat units from water at 32°.	Heat of va- porization. Latent heat units.	Weight of cubic foot in pounds.	Volumes of one pound in cub. feet.
1	101.99	1113.1	1043.0	.00299	334.5
2	126.27	1120.5	1026.1	.00576	173.6
3	141.62	1125.1	1015.3	.00844	118.5
4	153.09	1128.6	1007.2	.01107	90.33
5	162.34	1131.5	1000.8	.01366	73.21
6	170.14	1133.8	995.2	.01622	61.65
7	176.90	1135.9	990.5	.01874	53.39
8	182.92	1137.7	986.2	.02125	47.06
9	188.33	1139.4	982.5	.02374	42.12
10	193.25	1140.9	979.0	.02621	38.15
15	213.03	1146.9	965.1	.03826	26.14
20	227.95	1151.5	954.6	.05023	19.91
25	240.04	1155.1	946.0	.06199	16.13
30	250.27	1158.3	938.9	.07360	13.59
35	259.19	1161.0	932.6	.08508	11.75
40	267.13	1163.4	927.0	.09644	10.37
45	274.29	1165.6	922.0	.1077	9.285
50	280.85	1167.6	917.4	.1188	8.418
55	286.89	1169.4	913.1	.1299	7.698
60	292.51	1171.2	909.3	.1409	7.097
65	297.77	1172.7	905.5	.1519	6.583
70	302.71	1174.3	902.1	.1628	6.143
75	307.38	1175.7	898.8	.1736	5.760
80	311.80	1177.0	895.6	.1843	5.426
85	316.02	1178.3	892.5	.1951	5.126
90	320.04	1179.6	889.6	.2058	4.850
95	323.89	1180.7	886.7	.2165	4.619
100	327.58	1181.9	884.0	.2271	4.403
105	331.13	1182.9	881.3	.2378	4.205
110	334.56	1184.0	878.8	.2484	4.026
115	337.86	1185.0	876.3	.2589	3.862
120	341.05	1186.0	874.0	.2695	3.711
125	344.13	1186.9	871.7	.2800	3.571
130	347.12	1187.8	869.4	.2904	3.444
140	352.85	1189.5	865.1	.3113	3.212
150	358.26	1191.2	861.2	.3321	3.011
160	363.40	1192.8	857.4	.3530	2.833
170	368.29	1194.3	853.8	.3737	2.676
180	372.97	1195.7	850.3	.3945	2.535
190	377.44	1197.1	847.0	.4153	2.408
200	381.73	1198.4	843.8	.4359	2.294

EXPANSION OF STEAM.

When saturated steam expands in a non-conducting cylinder, and during its expansion performs mechanical work, its pressure falls on account of increase of volume and because of liquefaction. Rankine's approximate rule for the relation between pressure and volume, expanding under the above conditions is "*The pressure varies nearly as the reciprocal of the tenth power of the ninth root of the space occupied ;*" that is,

$$p = \text{pressure and } v = \text{volume ;}$$

$$\text{then, } pv^{1.0} \text{ or } pv^{\frac{1}{v^{1.0}}}$$

$$\text{or, } pv^{1.0} = \text{constant.}$$

This curve is very nearly an adiabatic curve, and falls considerably below the hyperbolic or isothermal curve.

Although the above is useful in certain theoretical investigations, it is of little practical use, because non-conducting and non-radiating cylinders do not exist.

In steam engines fitted with good steam jackets, in which steam enters in a moist condition, a considerable quantity of the heat passes from the jacket to the steam in the cylinder. When this quantity of heat is sufficient, not only to do the work performed by the steam, but also to convert a portion of the wet steam into dry saturated steam during the expansion, the relation between pressure and volume is approximately expressed by Boyle's law, viz.:

$$\text{pressure} \times \text{volume} = \text{constant,}$$

and the curve is an hyperbola. The hyperbolic curve is usually adopted for rough calculations in expansion. Boyle's law may be briefly stated as follows: *The pressure of a portion of gas at a constant temperature varies inversely as the space it occupies.*

The following examples will show clearly the application of Boyle's Law:

I.—Back pressure 4 lbs., steam pressure 30 lbs., clearance $\frac{1}{2}$ ". How far must piston be from end of its stroke at compression to compress the enclosed vapor in cylinder, so that the pressure shall rise to that of the steam in the steam chest.

Steam in the clearance space has a volume of $\frac{1}{2}$ " at 30 lbs. pressure. The back pressure has to increase from 4 lbs. to 30 lbs.; therefore, the volume has to decrease from 30 to 4, or $\frac{2}{15}$. At compression the steam occupies $\frac{2}{15}$ of $\frac{1}{2}$ " = $3\frac{1}{15}$ ". From $3\frac{1}{15}$ " deduct the amount of clearance, $\frac{1}{2}$ ", and we get $3\frac{1}{15}$ " as the distance the piston is from the end of stroke where compression began.

II.—Steam pressure 45 lb. gauge, cut off at $\frac{1}{6}$ lb. stroke. Find the mean pressure.

Method—Draw a horizontal line *AB* to represent the length of the stroke and also the line of volumes, divide this line into 6 equal

Telephone 1853.

WILLIAM C. WILSON & Co.,

IMPORTERS

DEALERS

OILS

High Class Lubricating Oils and Greases

FOR ALL KINDS OF MACHINERY.

**Steam,
Locomotive
and
Hydraulic
Packings**



**MAGNABESTOS PIPE COVERING
and ASBESTOS CEMENT.**

Head Office: 24 Front St. East,
Warehouse: 184 Front St. East, **Toronto, Ont.**

parts. From *A* erect a perpendicular *AC* to scale representing line

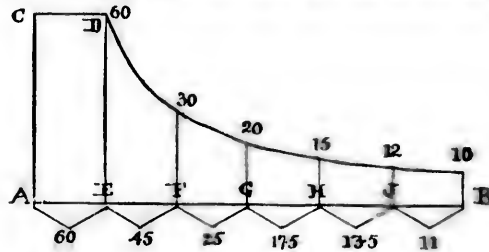

of pressures. In all steam calculations the pressure must be taken from zero or absolute, therefore 45 lbs. gauge pressure is equal 60 lbs. absolute. The line *AC* will represent 60 lbs., and as cut off does not take place until the piston has travelled $\frac{1}{3}$ of the stroke we will have the same pressure all the way along from *C* to *D*. At *D* the valve is closed and the rest of the work done in the cylinder is by expansion. At the point *F* which is $\frac{2}{3}$ or $\frac{1}{2}$ of the stroke, the volume of the steam has increased to twice its original amount, therefore its pressure will be $\frac{1}{2}$ or 30 lbs. At *G* the volume is increased to 3 times the original volume, therefore its pressure is only $\frac{1}{3}$ or 20 lbs. At *H* volume is 4 times pressure = 15 lbs., and at *J* the pressure is 12 lbs., corresponding to 5 times the original volume; and at the end of the stroke the piston has moved over 6 times the distance *AE*, therefore pressure is only $\frac{1}{6}$ of the original = $\frac{1}{6}$ of 60 lbs. = 10 lbs.

The mean pressure is obtained by taking the sum of the average pressures between the points of division on the diagram, and the dividers by the number of divisions, as follows: the average pressure

between *A* and *E* is 60 lbs., between *E* and *F* = $\frac{60 + 30}{2} = 45$, and so on, and taking the sum of these and dividing by 6 we get 28.66 lbs. as the mean pressure.

Suppose this engine had $\frac{1}{6}$ of the cylinder volume of clearance. (This is an excessive amount, but it is to show the effects of clearance to a somewhat enlarged extent on the diagram).

Proceed as before, and draw *AB* to represent the stroke of the engine + $\frac{1}{6}$ of the stroke, or *AB* = $\frac{7}{6}$ of the stroke of engine. Divide *AB* into 7 parts. The first of these will represent the amount of clearance to the same scale as the stroke, and the distance *AE* will

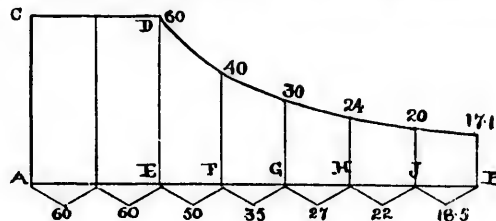

represent the amount of steam there is when piston has travelled $\frac{1}{6}$ of its stroke or to the point when valve has just closed. When piston has

travelled to *F* the volume has increased from 2 to 3, therefore pressure has decreased from 60 to 40. The pressure at *G* is 30 lbs., because volume has doubled, and so on, when we arrive at the end of the stroke with a pressure of 17.1 lbs. By taking the means of these and adding them, and then dividing by 7 we get an average pressure of nearly 39 lbs.

RATIO OF EXPANSION.

The ratio of expansion as usually understood is the ratio of the cylinder volume to that of the volume of the cylinder at point of cut-off, or the ratio of the length of the stroke to that part of the stroke travelled by the piston up to the point of cut-off, or

$$\begin{aligned} \text{Ratio of Expansion} &= \frac{\text{cylinder volume}}{\text{volume to point of cut-off}} \\ &= \frac{\text{length of stroke}}{\text{length of stroke to point of cut-off}} \end{aligned}$$

If clearance is taken into account the *true* or *actual ratio* of expansion is much less than the ratio given above.

$$\text{The actual ratio of expansion} = \frac{\text{cylinder volume} + \text{clearance}}{\text{volume to cut-off} + \text{clearance}}$$

No. of volumes to which the initial volume is expanded.

Example—Stroke 4 feet; clearance $\frac{1}{2}$; cut-off at $\frac{1}{4}$ stroke. Find ratio of expansion (1) without clearance, (2) with clearance. Ans.—4; $3\frac{1}{4}$.

EXPANSION OF STEAM.

Let *L* = length of stroke in inches.

t = distance travelled by the piston before steam is cut off, in inches.

C = clearance in inches.

P = initial absolute pressure.

p = mean pressure during stroke, in lbs.

R = actual rates of expansion = $\frac{L+C}{t+C}$

H = hyp. log. of *R*.

$$K = \frac{1+H}{R}$$

To Find the Mean Pressure—

$$\begin{aligned} p &= P \left(\frac{1 + \text{hyp. log. } R}{R} \right) & (1) \\ &= P \left(\frac{1+H}{R} \right) = P.K. \end{aligned}$$

To Find the Initial Pressure—

$$P = \frac{p}{K} = p \left(\frac{R}{1+H} \right) & (2)$$

To Find the hyp. log. of *R*—

$$H = \frac{pR}{P} - 1 & (3)$$

To Find the Ratio of Expansion—

$$R = \frac{P(1+H)}{p} \quad (4)$$

The values of R , H and K can be readily found in the following table when the point of cut-off is known :

Cut-off.	Ratio of Expansion.	Hyper. log. R .	$\frac{K \text{ or } 1 + \text{hyp. log.}}{R}$
$\frac{1}{10}$	10	2.302	.3302
$\frac{2}{10}$	9.5	2.251	.3422
$\frac{3}{10}$	9	2.197	.3552
$\frac{2}{17}$	8.5	2.140	.3694
$\frac{1}{8}$	8	2.079	.3849
$\frac{2}{15}$	7.5	2.015	.4020
$\frac{1}{7}$	7	1.946	.4208
$\frac{1}{13}$	6.5	1.872	.4418
$\frac{1}{6}$	6	1.791	.4653
$\frac{2}{11}$	5.5	1.705	.4917
$\frac{1}{5}$	5	1.609	.5219
$\frac{2}{9}$	4.5	1.504	.5564
$\frac{1}{4}$	4	1.386	.5965
$\frac{2}{7}$	3.5	1.252	.6438
$\frac{1}{3}$	3	1.098	.6962
$\frac{2}{5}$	2.5	.916	.7666
$\frac{1}{2}$	2	.693	.8465
$\frac{2}{3}$	1.5	.405	.9370
1	1	.000	1.0000

Note—From the results obtained by the above rules, the back pressure has to be deducted.

The following examples will show the method of working the various formulæ :

Example I.—Initial pressure 120 lbs. absolute. Cut-off $\frac{1}{4}$ stroke. Back pressure 21.58 lbs. Find mean effective pressure. $M. E. P.$ = mean forward pressure, — mean backward pressure. By Formula (1) we get

$$\begin{aligned} M. E. P. &= 120 \left(\frac{1 + \text{hyp. log.}}{4} \right) - 21.58 \\ &= 120 \left(\frac{1 + 1.386}{4} \right) - 21.58 = 50 \text{ lbs.} \end{aligned}$$

Example II.—The $M. E. P.$, as measured on a diagram, is 56 lbs. The scale of the diagram is $\frac{1}{16}$, and the back pressure line is $\frac{1}{8}$ of an inch above the atmospheric line. If cut-off takes place at $\frac{1}{6}$ th stroke, find the initial gauge pressure. By Formula (2),

$$\begin{aligned} P &= \frac{p}{k} = \frac{56 + \frac{1}{8} \text{ of } 40 + 15}{.5219} = 146 \text{ lbs. absolute} \\ &\text{or } 131 \text{ lbs. gauge.} \end{aligned}$$

Example III.—Find the hyp. log. when initial pressure is 120 lbs. absolute; cut-off at $\frac{1}{4}$ stroke; mean forward pressure 71.58 lbs. By Formula (3),

$$H = \frac{P R}{P} - 1 = \frac{71.58 \times 4}{120} - 1 = 1.386$$

To Find the Mean Pressure by the above table—

RULE: Find the value of K corresponding to the cut-off or ratio of expansion. Multiply this by the initial absolute steam pressure, and from the product subtract the back pressure.

Example—The pressure as indicated by gauge is 100 lbs. Cut-off takes place at $\frac{1}{4}$ stroke. The engine is exhausting at 5 lbs. above the atmosphere. Find the *M. E. P.*

100 lbs. gauge = 115 lbs. absolute; 5 lbs. gauge = 20 lbs. absolute. In table, the value of K agreeing to cut-off at $\frac{1}{4}$ stroke is .6962 \therefore .6962 \times 115 = 80 lbs.

GRAPHIC METHOD OF FINDING THE MEAN PRESSURE.

From the centre A at the distance AC describe the arc CEB . From A measure off AD as distance equal to $\frac{1}{2}$ of AC . Join BD . This line BD represents the stroke of the engine and D represents the beginning of the stroke. From D measure off the distances as indicated by the ordinates $\frac{1}{4}, \frac{1}{3}, \frac{1}{2},$ etc., corresponding to $\frac{1}{4}, \frac{1}{3}, \frac{1}{2},$ etc., of the stroke. For instance: DF is equal to $\frac{1}{4}$ of the stroke, or

$\frac{DF}{DB} = \frac{1}{4}$. Make BC by construction = $\frac{1}{2}$. Then the ratio of the mean pressure to that of the initial absolute pressure is equal to the length of the ordinate corresponding to the point of cut-off divided by the length BC .

Example—The ordinate FF we find is $1\frac{2}{3}$, then $1\frac{2}{3} \div 2 =$ the ratio of the mean to the initial abs. pressure. If initial pressure was 100 lbs. then $1\frac{2}{3} \div 2 \times 100 = 69$ lbs. mean pressure.

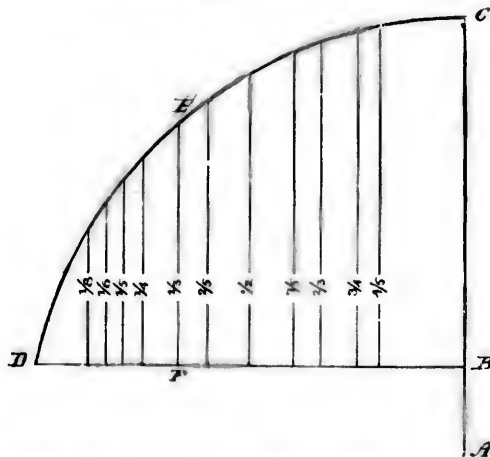

The following table gives the approximate length of the ordinates

in 32nds of an inch, together with the exact length in decimals :

Cut-off.	Ratio of Expansion.	Approx. length of ordinate.	Exact length of ordinate	Ratio of ordinate to B C.
$\frac{1}{8}$	8	$\frac{25}{32}$.77	.385
$\frac{1}{4}$	6	$\frac{23}{32}$.9306	.4653
$\frac{1}{2}$	5	$\frac{21}{32}$	1.044	.522
$\frac{3}{4}$	4	$\frac{19}{32}$	1.1930	.5965
$\frac{1}{2}$	3	$\frac{17}{32}$	1.3924	.6962
$\frac{1}{2}$	2.5	$\frac{15}{32}$	1.5332	.7666
$\frac{1}{2}$	2	$\frac{13}{32}$	1.6930	.8465
$\frac{1}{2}$	1.7	$\frac{11}{32}$	1.7820	.891
$\frac{1}{2}$	1.5	$\frac{9}{32}$	1.8740	.937
$\frac{1}{2}$	1.33	$\frac{7}{32}$	1.9200	.960

The Rule for finding the mean pressure by the above method is :

Divide the ordinate corresponding to the ratio of expansion by the length *BC* and multiply by the initial pressure.

Example The stroke of an engine is 24" and steam is cut off when piston has travelled 6". Find the mean pressure if the initial pressure is 115 lbs. absolute.

Ratio of expansion = $\frac{24}{6} = 4$. From table we get the length of the ordinate to be 1.1930, and this divided by 2 gives us .5965. This multiplied by 115 gives us the mean pressure = 68.6 lbs.

CARE OF STEAM BOILERS.

The management of Steam Boilers in all establishments is a subject of great importance, and one which does not, in many cases, receive the care and attention necessary in order to obtain the most economical results. When a steam user has decided to purchase a boiler, he should take steps to determine exactly what size and style will best suit his requirements.

If his engineer has the necessary ability, he should be requested to make an evaporative test of the plant, and also to indicate the engine in order to determine the exact amount of water required to be evaporated, and the number of horse power exerted by the engine.

Having this information, it is an easy matter to arrive at the dimensions of the boiler required; but it must be remembered that it is always in the interest of economy to have a boiler larger than is necessary for the actual requirements, as the grate surface can be proportioned to suit the case, fires can be run without any forcing, and good combustion and consequent economy of fuel secured, to say nothing of the increased length of the life of boilers used under these conditions. If the engineer has not the ability necessary to determine these points, then some engineer of ability and good

standing should be entrusted with the getting up of specifications both for the building of boiler and brickwork. The boiler should be inspected frequently during construction, and, when completed, it should be thoroughly inspected and tested to one and one-half times the pressure it is desired to work, by hydrostatic pressure.

After the boiler has been set in position and the brickwork completed, it should be allowed to stand, if possible, for a week in order to give the brickwork a chance to dry and set. After this, the boiler may be filled to the proper level and a small fire kept burning under it for a few days before being put to work, great care being used so as not to heat up the boiler and brickwork too quickly.

In starting up a new boiler, it is a good plan to put in a few lbs. of sal. soda with the water, and then, after brickwork is well dried and set, to let down fire and steam, run off the water and give the boiler a good washing out. This treatment will be found to prevent the foaming which so often happens when starting up a new boiler, and is caused by the grease left in it by boilermakers.

From the time a boiler is started to work certain influences are at work, which, if left to themselves, will materially shorten its term of usefulness and safety; and it is the duty of the engineer to use every effort to check and counteract them.

The importance of the duties of the engineer and fireman are not as fully understood by many of our steam users as they should be, and too many owners are inclined to think that everything is all right as long as the machinery keeps on the move. A good, intelligent, painstaking and thinking engineer or fireman, compared with the careless and indifferent man, will save his wages several times over. It is a well-known fact to many firms who have given the matter attention that a good fireman is almost invaluable, and that the difference in the fuel bill between a really good fireman and an indifferent man is astonishing at the end of a year.

The fireman should at all times, before starting his fire, see that the water in boiler is at proper level. He should not be satisfied by merely looking at the water-glass, but should open the cock at bottom of glass, and also try the gauge cocks. Many accidents have occurred by neglecting this duty.

When sure that the water is all right, he should see that blow-off cock is in order and closed, that the ashpit is clear of ashes, that the tubes are clean, and that the safety valve is raised off its seat, or that some valve or cock is open to the atmosphere until steam issues from it. The grate bars should now be covered (with coal) from the bridge wall toward the furnace door for about 3 feet, and should then put in some light wood on the grate in front of the coal, and with a little oily waste set fire to it.

When the fire has taken well hold of the wood a little coal may be put on it. During this time the ashpit should be closed and the furnace door left open a little in order that the flames may be communicated to the coal at the back of furnace.

As soon as a good fire is burning in the front of furnace, it may be pushed back a little and the ashpit damper opened. The fire should not be forced, but should be allowed to work up gradually,

as the unequal strains some boilers are subjected to through forcing the fire when boiler is cold have caused leakage, and made expensive repairs necessary. In boilers of the Galloway, Lancashire and Cornish type, it is necessary to use great care in firing up from cold water, owing to the temperature of the water in the lower part of shell remaining low for a considerable length of time. The fires should be maintained level and of a uniform thickness, but the thickness must be determined by the demand for steam, condition of the chimney draft, and quality and nature of the fuel.

The firing is best done when the combustion in furnace is good, and consequently but little dense smoke is given off. Dark spots in the fire, abundance of smoke, unsteady steam pressure, unsteady water line, dirty tubes, coal in ash heap, are all evidences of careless firing, and should not be tolerated. Experience is the only thing that will prove the best methods of handling the different kinds of fuel under the different conditions to be met with in practice.

In the boiler room there should be a place for everything, and everything should be kept in its place.

All the fittings, mountings, boiler front, etc., should be kept clean and free from leaks.

The coal should be put on fire at regular intervals and lightly. If the furnace is large, it may be advisable to coke the fire, *i.e.*, to fire the green coal in front of furnace and allow the smoke to pass over a bed of incandescent, full at the back, and be consumed; then push it back and add more coal in front.

Sometimes side firing works very well; *i.e.*, to always have one side of the fire incandescent when firing green coal on the opposite side. But no hard-and-fast rule can be set for every condition, and much must be left to the judgment of the fireman in each individual case. When firing or cleaning fires, where the chimney draft is very strong, it is advisable to check the stack damper to prevent too great a quantity of cold air entering the furnace and causing undue contraction of the plates. In boilers having large furnace, it is well when cleaning fires to clean one side at a time.

The fires should be banked at night, as it is more economical than to allow fires to burn out and re-light them in the morning, and it also saves the life of boilers to a certain extent, as, when fires are banked, the boiler is not subjected to so many strains by expansion and contraction.

The feed water should be kept constantly on, and the water-line maintained at the proper level all the time. Every day the steam pressure should be raised to the blowing-off point, so that the fireman may know that the safety valve is in working order. If at any time, from any cause, the gauge should show the pressure increasing rapidly up to or past the limit, the feed should at once be put on, draft checked, and in some cases it may be necessary to open the furnace doors. Should the water in boiler at any time get dangerously low, then close dampers and open smoke-box doors immediately, and cover fires with damp ashes, or, if there are none at hand, small green coal may be used. Do not put on the feed, but allow the boiler to cool down some. After this the feed may be put on, and

the tubes at back end examined for fear they may have been caused to leak from overheating.

If the water-gauge glass and try cocks are attached to a column, there should be a blow-off pipe from bottom of column of at least $\frac{1}{2}$ " diameter, and this pipe should be carried to main blow-off pipe or sewer, and should be blown off at least once every two hours.

In cases of foaming or priming, if not caused by faulty construction of boiler, it can usually be prevented by putting on more feed and opening blow-off, thus changing the water in the boiler. But if the foaming is very violent, it may be necessary (in order to determine the water-level in boiler) to close, or partially close, the engine throttle, open the furnace-door and increase the feed, and blow off the boiler a little at intervals. A surface blow-off cock is a good thing when a boiler foams, as by its use the scum and dirt can be cleared off surface of water.

A boiler should be cleaned out at regular intervals, but the length of time between such cleanings must be determined according to the nature of the feed water. A boiler using feed water from the Lake may be run for from six to eight weeks before cleaning, while on the other hand using feed water from a small stream it may be necessary in the spring of the year (when the water is very dirty) to clean the boiler every week.

When about to clean and wash out the boiler, the brickwork should be allowed to cool down as much as possible before the water is run off; then the hand hole covers should be taken out, and all mud and deposit removed by scraping out, then the hose should be used with a good water pressure and boiler washed out thoroughly. After this has been done the water should be all drained out of bottom of boiler, and a light put into it through hand hole to make sure that no scale or mud remains on the bottom.

The manhole should be taken out once every three months, when the fireman should go inside, and, with proper cleaning tools, scrape off all deposit and dislodge all accumulations of scale, which will fall to the bottom of shell and can be removed through the hand holes. After this has been done thoroughly, the boiler may be washed out well through the manhole. All joints should then be made, care being taken to make them perfectly tight, as, if allowed to leak and run down the boiler, it will cause corrosion of plates, and in time necessitate repairs. All soot and ashes should be removed from under boiler previous to commencing to wash out, and tube ends and bottom of boiler, seams, etc., should be carefully examined for leaks, and if any are found they should be caulked and made tight without delay, as, if left for any length of time, they will cause expensive repairs and delays. If the boiler is subject to inspection, the bottom of shell should be swept off, all dust and ashes removed from flues, and every facility given the inspector to enable him to do his work thoroughly.

A man in charge of a steam boiler should have a due sense of his responsibilities. He should be cool and collected in case of emergency, sober and industrious at all times, and should never put off till to-morrow the things that ought to be done to-day. This

article on Care of Steam Boilers is not written for experienced engineers, but rather for the young fireman who is seeking information, and who has a desire to advance in his chosen calling. If it is read by even a few of the latter and proves in any way beneficial to them, then one of the objects in publishing this book will have been accomplished.

BOILER SETTINGS.

The brick work about a boiler should be thick to prevent loss by radiation—a 21" wall should be used if possible. All flues and surfaces exposed to action of heat should be lined with the best fire brick.

It is not a good plan to convey gases back over top of boiler, unless there is space enough for a man to enter and clear off soot.

The distance from grate bars to lower portion of boiler shell should not be less than 24"; 26" and 28" are not too great, and in large shells 30" can be employed.

The bridgewall should curve to conform with the boiler shell. Ten (10) inches makes a good space between wall and shell. Back of bridge wall the surface should be paved with hard brick, the surface dipping down to a depth at the rear end of boiler of about 18" to 24", according to size of shell. The distance between back tubes, shell and back wall should be 18" for a 48" shell, and 24" for a 72" shell.

Boiler walls will crack, and no form of construction seems to entirely prevent this. Walls with air spaces are as liable as those without, with the danger of leaking more air when they do crack.

The best method to hold boiler walls together is with "brick-staves" or "brick-bars." The best form is railway iron with ends mashed down under a hammer to allow for drilling for tie rod. Most builders do not supply "brick-staves" unless specially ordered.

The cheapest form of fire front is the so-called "half-arch," which does not cover any more of the front of the furnace than is absolutely decent. On small boilers it is employed as a support. For a good job a "full flush front" should be used, with damper plate and damper.

Boilers, now-a-days, are not set in batteries, all to work together as a unit. They are, and should be, set so that each boiler is independent of the others in the battery. In this way, any one can be shut down for cleaning and repairs. This arrangement does away with the old-fashioned steam and mud-drums, which connected the boilers of the battery together. Do not buy either a mud-drum or steam drum—they are a source of trouble, danger and expense.

EVAPORATIVE TESTS.

It is important to owners of steam plants that they should sometimes take steps to determine whether the efficiency of the plant is up to the standard; or, in other words, to determine whether or not the fuel which is being consumed under the boilers is evaporating as much water as is possible. The heat value of coal varies considerably, and it is very seldom that this fact is taken notice of by engineers in making evaporative tests. There are three different methods of

determining the caloric value of fuels, viz.: by chemical analysis, by use of the calorimeter, and by the actual measurement of water evaporated per pound of fuel consumed in the furnace. The first process is of course impossible for an engineer to accomplish, and would require the services of an analytical chemist, and even then the result would be only approximate. The second method is probably more satisfactory, and its operation is as follows: A sample of the fuel to be tested, mixed with chlorate of potassium, is placed in a copper vessel with an open mouth, and this is submerged mouth downwards in water of a known quantity. Combustion then takes place and the heat value of the coal is determined from the rise in temperature of the water. If the second method be used to determine the value of a fuel, and in order to secure fairly accurate results, it is necessary to test a large number of samples taken from different parts of a pile, so as to ensure average results. In most of the evaporative tests made no thought is given to the heat value of the fuel, yet the qualities of coal vary just as much as other articles of commerce.

The third and most practical method of determining the value of coal is to test it for evaporative duty under a clean, well designed and well set boiler, for it matters but little what may be the value of a fuel according to the analysis, or the calorimeter test, when we can only obtain certain results from it when consumed in the furnace of a steam boiler, and it is by this test that we must determine the value of our fuel and the efficiency of our steam boilers and engines.

To rightly determine the heat value of any fuel (for comparative purposes and to do justice to the fuel) it is necessary that all conditions as regards style of boiler, setting, draft, ratio of grate to heating surface and skill in handling the fuel shall be the same, therefore it would be most unjust to condemn a fuel because in a test at Messrs. A. & Co. only $6\frac{1}{2}$ lbs. of water were evaporated per lb. of coal, because a test might be made at Messrs. B. & Co. using the same fuel and result in showing an evaporation of $8\frac{1}{2}$ to 9 lbs. of water per lb. of coal.

It may be misleading to judge of the value of a fuel on the strength of a test made at So and So's establishment, and equally so to condemn a boiler on the report of an evaporative test, as it is absolutely necessary to know all the conditions under which the test was made before reaching any conclusion as to the value of the fuel or the efficiency of the boiler.

It is interesting to notice the different grades of combustion attained in our industrial establishments, as indicated by the output of smoke from the chimneys. In some places we see vast volumes of black smoke rolling away, and in others just a light smoke is noticeable, and it only for a few moments after charging the furnace with green coal. In many instances, where a large quantity of smoke is sent off from the chimney, it could be very much reduced by careful stoking and some knowledge of the laws of combustion.

Whenever large quantities of smoke issue from the chimney, we know there is a waste of fuel through poor combustion; consequently, the evaporative duty of the coal will be less than it should be, according as the combustion is good, bad or indifferent.

W
bustio
that
tempe
to thi
tempe
to ind
furnac

It
surface
requir
minim
over 4

In
of tes
shoul
of fro
these
perfor
scales
For th
each s
them
dimen
water
test is
then t

T
for th
prefer
take t

A
near w
and o
scales

W
the us
fire of
water
the po
hand,
the re
be do

S
menc
any is
total.

T
in tak
a corn
shoul

We know we can never utilize all the heat generated by combustion by transferring it to the water in the boiler, for the reason that the gases from furnace cannot be reduced lower than the temperature of steam and water within the boiler, and, in addition to this, a certain amount of heat is necessary over and above the temperature of the atmosphere to induce draft in the chimney so as to induce the necessary amount of air for combustion to enter the furnace through the burning fuel.

It is possible, by proper proportioning of grate surface to heating surface, and chimney area to grate area, and size of boiler to work required of it, to reduce the temperature of chimney gases to the minimum; and, if all conditions are favorable, they should not be over 400° F.

In making an evaporative test, it is necessary that the duration of test should not be less than for ten hours, and to be of any value should be made very carefully, and will usually require the services of from two to three extra men to assist the regular attendants, and these men should have some knowledge of the duties they have to perform. It will be necessary to have three accurate platform scales, one for weighing the coal and two for weighing the water. For the water two good tight barrels or tanks are required, one on each scale, and arrangements should be made for filling and weighing them alternately. Sometimes the water is drawn from tanks, the dimensions of which have been previously taken and the weight of water they hold computed, so that all that is necessary during the test is to keep a tally on the number of times each tank is filled, then the total weight of water can be computed at end of the test.

The readings of a water meter on feed pipe have also been taken for the water; but as they are not likely to be quite correct, it is preferable to use two tanks, each on a separate platform scale, and take the actual weight of each as it is filled alternately.

A reliable thermometer should be placed in a tee in feed pipe, near where it enters the boiler, and another in the uptake to chimney, and one also in the pipe conveying the feed water into the tanks on scales.

When commencing the test, say at 7 a.m., steam should be up to the usual pressure, the ashpit and furnace all cleaned out, and a light fire of wood laid on grate; the tubes all cleaned, and the height of water in gauge glass marked by tying a piece of string round it at the point where water reaches up to. The attendants should be on hand, each having sheets of paper properly ruled off for recording the readings of the various gauges, thermometers, etc. This should be done every fifteen minutes.

Several boxes of coal should be weighed out previous to commencing the test, so that the fireman may have a little ahead, and if any is left when test is over it can be weighed and deducted from the total.

The utmost care should be taken in weighing the coal and water, in taking the readings of the different gauges and thermometers, if a correct test is wanted, and to obtain this none of the attendants should have more to do than can be done easily.



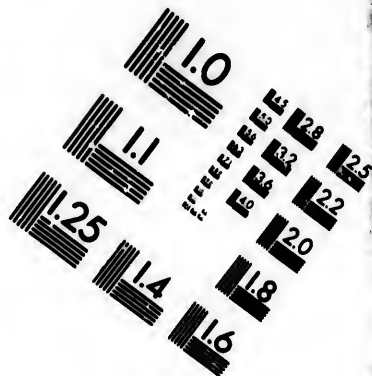
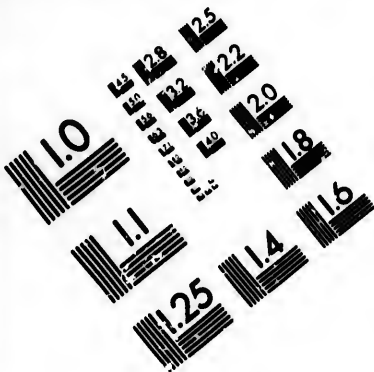

**IMAGE EVALUATION
TEST TARGET (MT-3)**

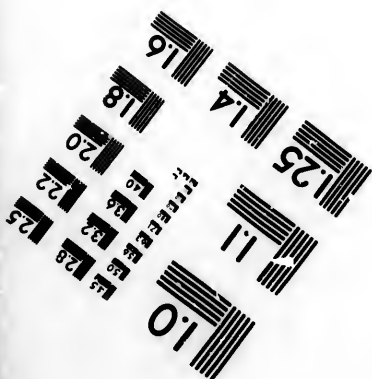
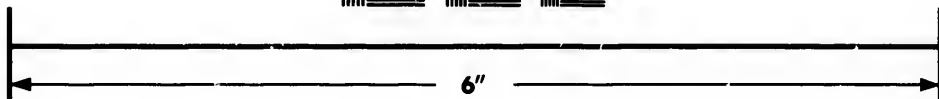
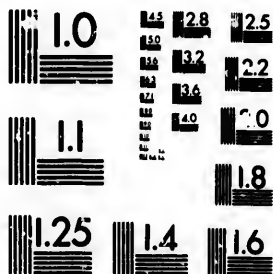

**Photographic
Sciences
Corporation**

23 WEST MAIN STREET
WEBSTER, N.Y. 14580
(716) 872-4503

0
E 28
E 32
E 25
E 22
E 20
E 18

10
E

If the plant shuts down at noontime the drafts may be closed, fires carefully banked and some person left to look after them, who must not allow pressure to exceed the average or safety valves to blow off, if possible; but it is much preferable, if it can be arranged, to continue the operation of the plant till the end of the test.

When the time comes to close the test, the water feed should have been so adjusted that the water in gauge glass is just up to the string which was tied on glass at starting, and any water remaining in weigh tank should be weighed and deducted from the last entry.

Any coal remaining should also be weighed and deducted from the last entry of weighing.

The fire in furnace should be hauled out and weighed, and its weight deducted from the total weight of coal consumed.

The ashes should also be weighed, and note taken of their weight.

The net weights of both water and coal should then be carefully added up, and entered in following manner:—

TEST OF..... BOILER AT MESSRS.....

Day of, 18....

Dimensions.

No. of flues and diameter.

Size of fire grate.

Heating surface.

Diameter of chimney.

Height of chimney.

Duration of test hours.

Kind of fuel used.

Boiler pressure by gauge ... lbs.

Temperature of feed water entering boiler°F.

Temperature of feed water entering pump°F.

Total quantity of fuel burned lbs.

Percentage of moisture in fuel %.

Equivalent dry fuel lbs.

Total weight of ashes lbs.

Equivalent combustible lbs.

Total water evaporated lbs.

Water evaporated per hour lbs.

Water evaporated per lb. dry fuel lbs.

Water evaporated (per lb. dry fuel) from and at
212°F. lbs.

Water evaporated per lb. of combustible from and at
212°F. lbs.

Horse power developed H.P.

To find the % of moisture in fuel, take a fair sample of it and weigh it, then let it dry for 24 hours and weigh it again when dry, then the difference between the wet and dry weights multiplied by 100 and divided by the wet weight of the sample will give the percentage of moisture.

To find the water evaporated per hour, divide the total quantity of water evaporated by the duration of test in hours.

To find the water evaporated per lb. of dry fuel, divide total quantity of water evaporated by the total quantity of dry fuel burned.

To find the equivalent combustible, subtract the weight of ashes and clinker from the total weight of fuel burned.

To find the equivalent dry fuel, multiply the total quantity of fuel burned by the % of moisture and divide by 100, then subtract the quotient from the total quantity of fuel burned.

To find the quantity of water evaporated from and at 212°F. (this is the usual standard), multiply the total heat or heat units in 1 lb. of steam at average pressure maintained during test (less the total heat of 1 lb. of feed water before entering the pump), by the quantity of water evaporated per lb. of fuel and divide the product by 966, which is the total heat units contained in 1 lb. of steam at 212°F. This is called the equivalent evaporation, and is used to reduce tests to a common standard for comparison. It is expressed

thus: $W' = W \frac{H - t^\circ}{966} = \text{equivalent evaporation.}$

W = lbs. of water evaporated per lb. of coal.

t° = temperature of feed as supplied (calculated from zero).

H = total heat of steam in B, T, H, U , at average pressure of test.

W' = The equivalent evaporation from and at 212°F.

To find the H. P. developed, subtract the total heat units of 1 lb. of feed water before entering the pump or injector, as the case may be, from the total heat units in 1 lb. of steam at average pressure of test, and multiply the product by the quantity of water evaporated per hour, and divide by 1103.4 (which is the heat units necessary to raise 1 lb. of water from 100°F. and evaporate it into steam at 70 lbs.) and this quotient divided by 30 will give the H.P., as decided at the Centennial Exhibition.

The following is an example of finding the equivalent evaporation from and at 212°F. :

Water evaporated per lb. of fuel = 8 lbs.

Average temperature of feed water = 40°F.

Average pressure by gauge = 60 lbs.

Total heat of 1 lb. of steam at 60 lbs. = 1175.71 heat units.

Total heat of 1 lb. of feed water at 40°F. = 8 heat units.

$$\text{Then } \frac{1175.71 \times 8 - 8}{966} = 9.73 \text{ lbs. from and at } 212^\circ\text{F.}$$

In making these tests great care must be taken in the details, for if any guess work is allowed the test becomes worthless.

THE INJECTOR.

Injectors are chiefly used for locomotives, these being seldom fitted with feed pumps in modern practice. Injectors will draw water from 2' to 12' feet, according to size, but the water supply must be continuous and must not be hotter than 135° F. for low pressures, and 105° F. for the highest pressures. If these temperatures are exceeded, so much water is required to condense the steam that the

velocity of the steam is too much reduced in driving forward the large volume of water,

Steam is admitted to the injector through a conical nozzle, and its admission is regulated by a spindle, the lower end of which fits accurately into the nozzle. The water with which the boiler is to be fed enters the injector on the opposite side from the steam and through a branch a little below the steam pipe branch.

By admitting steam and water by their respective branches, the steam is able to drive the water into the boiler against a pressure which is equal to, or it may be greater than its own. This may seem paradoxical, but, nevertheless, it is the case, and the explanation is as follows: The velocity of an issuing jet of steam is many times greater than that of a jet of water issuing under the same pressure, and if steam, while issuing from the boiler, be condensed to water, but not reduced in velocity to that of the water issuing under the same pressure, it is then capable of overcoming the pressure of the water in its own boiler. This is exactly what takes place in the Gifford's injector: The steam enters the injector, and passing down the conical nozzle is condensed on coming into in contact with the feed water, without losing its velocity, further than that due to the friction of the passages. The vacuum formed in the injector by the condensation of the steam, causes more water to rush into the injector and this feed water is carried on by the force of the condensed steam jet into the boiler.

HEATING OF FEEDWATER.

A due regard for economy in the production and saving of power requires that that contained in the heat of exhaust steam be applied to some useful purpose, and as a rule is best utilized in raising the temperature of the feedwater to the highest point of which it is economically capable. To effect this the heater is used; and when in addition to this duty it is possible, by its use, to eliminate most of the impurities contained in the water, its great value to an economical steam plant will be acknowledged and appreciated.

That the feedwater heater is a most important feature in a steam plant can be very easily proved by the following: Boiler pressure, 60 lbs. gauge. Feedwater, 40° before and 200° after it goes through heater. What is the percentage gained by using the heater?

Temperature of steam at 60 lbs. pressure =	307
Latent heat units in steam at 60 lbs. ... =	899
Total heat units	= 1206

The total heat supplied per lb. of steam is = 1206 - 40, if there were no feedwater heater = 1166 heat units; but feedwater heater increases

the temperature from 40 to 200 or 160° gain in heat $\therefore \frac{160 \times 100}{1166} = 13.71\%$.

By increasing the temperature of the feed from 40 to 200 there is a gain of 13.71%.

To Find the Percentage Gain by Heating Feedwater—

RULE: Divide 100 times the difference between the final and

initial feed temperatures by the total heat units in the steam minus the initial temperature of the feed.

$$\text{Formula, } 100 \left\{ \frac{\text{Final temp. of feed} - \text{Initial temp. of feed}}{\text{Total heat units in steam} - \text{Initial temp. of feed}} \right\}$$

Example—Initial temperature of feedwater, 45°; final temperature, 210°; steam pressure, 100 lbs. gauge. Find % gain. Ans.—14.1%

The following table shows the per cent. saving by heating the feedwater at 60 lbs.:

Initial temp. of water	Final temperature of feedwater.						
	120	140	160	180	200	250	300
35	7.25	8.96	10.66	12.09	14.09	18.34	22.60
40	6.85	8.57	10.28	12.00	13.71	17.99	22.27
45	6.45	8.17	9.90	11.61	13.34	17.64	21.94
50	6.05	7.71	9.50	11.23	13.00	17.28	21.61
55	5.64	7.37	9.06	10.85	13.60	16.93	21.27
60	5.23	6.97	8.72	10.46	12.20	16.58	20.92
65	4.82	6.56	8.32	10.07	11.82	16.20	20.58
70	4.40	6.15	7.91	9.68	11.43	15.83	20.23
75	3.98	5.74	7.50	9.28	11.04	15.46	19.88
80	3.55	5.32	7.09	8.87	10.65	15.08	19.52
85	3.12	4.90	6.63	8.46	10.25	14.70	19.17
90	2.68	4.47	6.26	8.06	9.85	14.32	18.81
95	2.24	4.04	5.84	7.65	9.44	13.94	18.44
100	1.80	3.61	5.42	7.23	9.03	13.55	18.07
110	.90	2.73	4.55	6.38	8.20	12.76	17.28
120	.00	1.84	3.67	5.52	7.36	11.95	16.49
130		.92	2.77	4.64	6.99	11.14	15.24
140		.00	1.87	3.75	5.62	10.31	14.99
156			.94	2.83	4.72	9.46	14.18
160			.00	1.91	3.82	8.59	13.37
170				.96	2.89	7.71	12.54
180				.00	1.96	6.81	11.70
200					.00	4.85	9.93

Example - The initial temperature of the feedwater is 85° F., and the final temperature 180°. Find the per cent. gained if gauge pressure is 60 lbs. Ans.—8.46%.

PUMPS.

To Find the Capacity of a Pump, per Stroke, in Gallons—

RULE: Multiply the area of the cylinder by the length of the stroke and divide by 277.27.

$$\text{Formula, } \frac{\text{Area of cylinder} \times \text{length of stroke}}{277.27} =$$

$$\frac{D^2 \times .7854 \times L}{277.27} = \frac{D^2 \times L}{352.8} \quad (1)$$

To Find the Capacity of a Pump, per Stroke, in Lbs.—

RULE: Multiply the area of the cylinder by the length of stroke and divide by 27.727.

$$\begin{aligned} \text{Formula,} &= \frac{\text{Area of cylinder} \times \text{length of stroke}}{27.727} \\ &= \frac{D^2 \times L}{35.28} \end{aligned} \quad (2)$$

To Find the Capacity of a Pump in Gallons, per Minute—

RULE: Multiply (1) by number of strokes per minute.

$$\text{Formula,} = \frac{D^2 L \times \text{No. of strokes}}{352.8} \quad (3)$$

To Find the Capacity of a Pump in Lbs. per Minute—

RULE: Multiply (2) by number of strokes per minute.

$$\begin{aligned} \text{Formula,} & \frac{D^2 L \times \text{No. of strokes}}{35.28} = \\ & (3) \text{ multiplied by } 10. \end{aligned} \quad (4)$$

To Find the Horse-power required to raise water a given height—

RULE: Multiply the volume in cubic feet per minute, by pressure per square foot and divide by 33000, or weight of water in lbs. \times height of lift divided by 33000.

$$\begin{aligned} \text{Formula,} &= \frac{\text{Vols. in cub. ft. per minute} \times \text{press. per sq. ft.}}{33000} \\ &= \frac{\text{Weight of water in lbs.} \times \text{height of lift}}{33000} \end{aligned}$$

Certain allowance should be made for friction, etc., varying from 15 to 25%.

Example—What power is required to raise 600 cubic feet of water per minute, lifting it 20' and then forcing it to 140' in height.

Total height of water to be raised = 140 + 20 = 160'

Total weight of water to be raised = 600 \times 62.4 = 37440 lbs.

$\therefore \frac{160 \times 37440}{33000} = 181.5$ H.P., and allowing 25% for friction gives us 227 H.P.

The height of a column of water is equal to pressure per square inch \div .433 = pressure per square inch \times 2.309.

Example—What power is required to raise 1000 gallons of water per minute, lifting it 20' and forcing it against a pressure of 60 lbs. per square inch. Allow 25% for friction. Ans.—60 H.P.

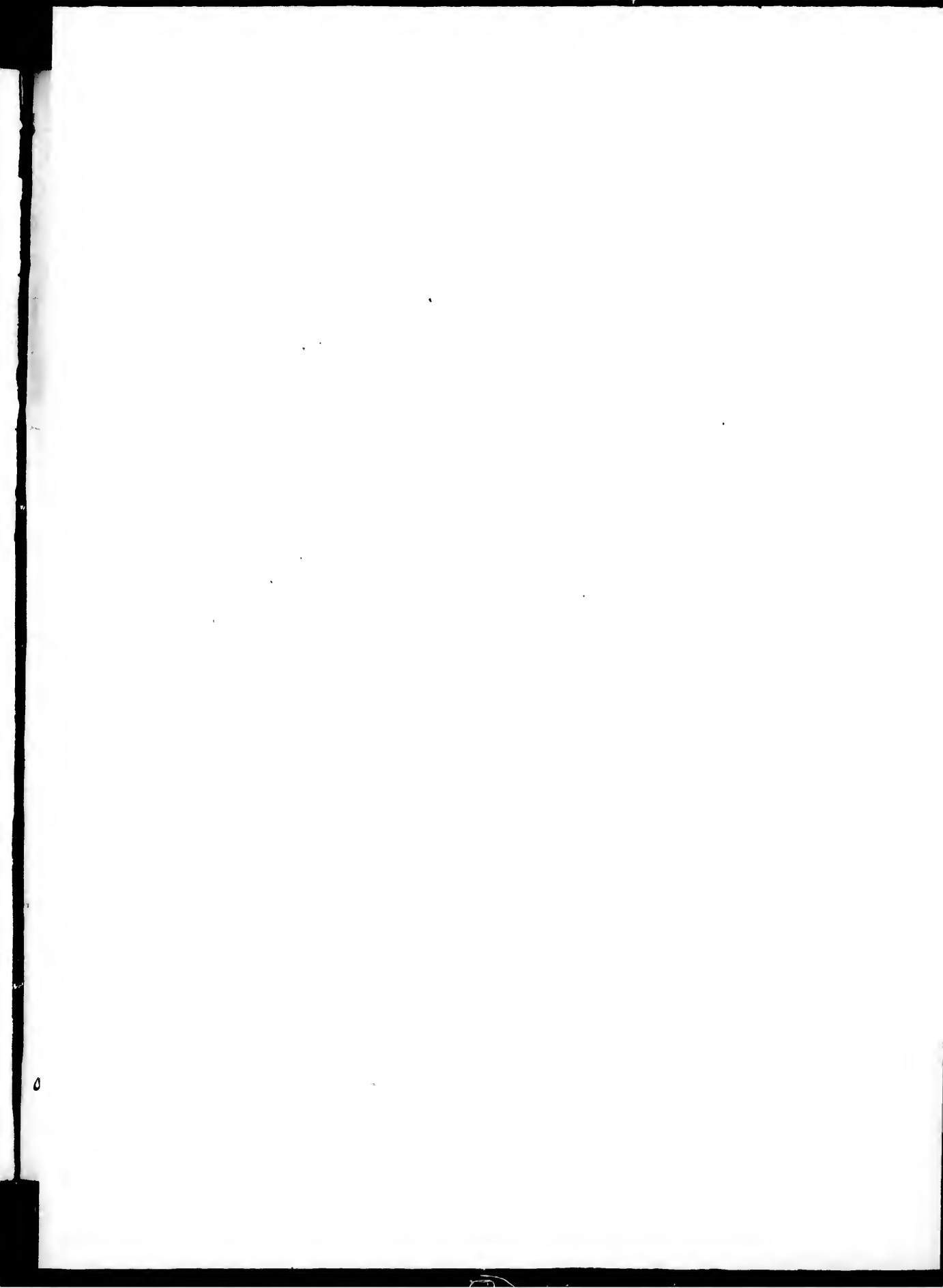

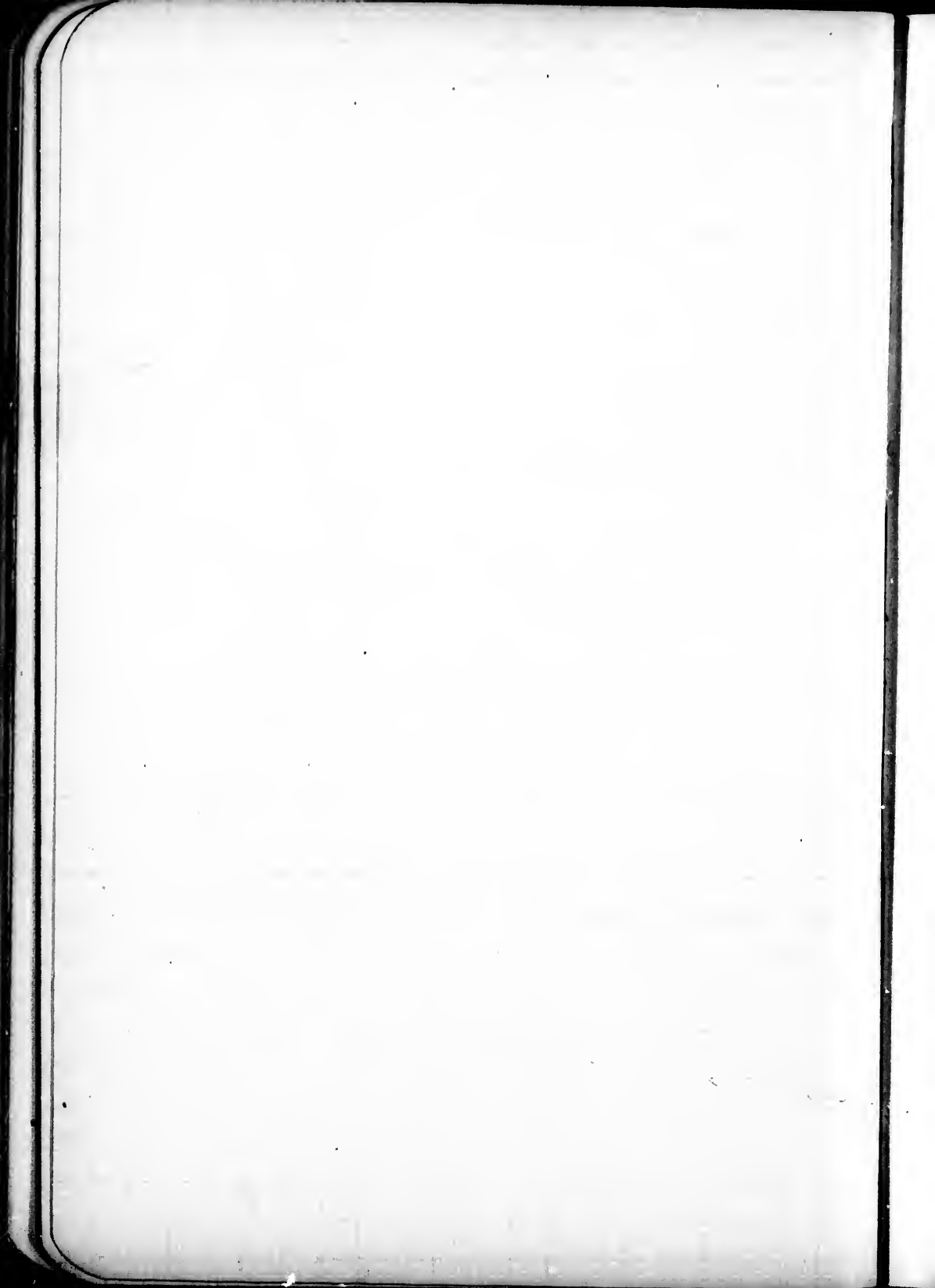

TO SET THE VALVES OF A WORTHINGTON DUPLEX PUMP.

The steam valve of this pump has no outside lap, consequently, while in its central position, it just covers the steam ports leading to opposite ends of the cylinder. To set the piston in the middle of its stroke, open the drip cocks and move the piston by prying on the crosshead (not on the lever), until it comes into contact with the cylinder head; make a mark on the piston rod at the face of the steam end of the stuffing box follower; move the piston back to contact stroke at opposite end. Make second mark on piston rod halfway between first mark and the follower. Then if the piston is again moved back until second mark coincides with face of same follower, it will be exactly at the middle of its stroke. Bear in mind that one piston moves valves on opposite side. (a) When the steam valve is moved by a single valve rod nut, as is the case with pumps having less than 10-inch stroke. Place one piston in the middle of its stroke; disconnect link from head of valve rod on opposite side; then set the valve in its 'central position'; place valve nut evenly between jaws on back of valve; screw valve rod in or out until eye on valve rod head comes in line with eye of valve rod link; then reconnect. Repeat the operation on opposite side and the valves will be properly set. (b) When the valve rod has more than one lock nut, as is the case with pumps having 10 inch stroke and over. Place one piston in the middle of its stroke and opposite side valve in 'central position'; adjust lock nuts, allowing about $\frac{1}{16}$ inch 'lost motion' on each side of jaw. Do not disconnect the valve motion. Repeat operation on opposite side. By 'lost motion' is meant the distance a valve rod travels before moving the valve; or, if the steam chest cover is off, the amount of 'lost motion' is shown by the distance the valve can be moved back and forth before coming in contact with the valve rod nut. To divide the 'lost motion' equally move valve each way until it strikes the nut or nuts, and see if port openings are equal. It is advisable that both pistons be placed at the middle of their strokes before touching either slide valve. When the stroke of a pump is too long, that is, when piston strikes the heads, the 'lost motion' should be reduced; contrariwise, when the stroke is too short, increased 'lost motion' will tend to lengthen it.

STRENGTH OF SOLID ROUND SHAFTING.

The resistance to tension in solid round shafts is directly proportional to the cubes of their diameters, when made of the same material and quality. This is evident from the fact that the shaft must offer a *moment of resistance* or *shearing moment* equal to the *twisting moment*

at the instant of rupture. The area to be sheared is $= \frac{\pi}{4} d^2$ when d = diam. of the shaft. The mean arm or leverage at which this resistance acts is equal to half the radius of the shaft for at the centre the leverage is $= 0$ and at the circumference it is equal to the radius of the shaft. The mean arm is therefore $= \frac{r}{2} = \frac{d}{4}$.

Let S = shearing resistance per square inch of cross section of the material, P = force applied at the end of the lever or circumfer-

ence of the pulley ; R = the radius of wheel, a pulley, or length of arm.

$$\begin{aligned} \therefore P \cdot R &= S \left(\text{area of shaft} \times \frac{d}{4} \right) \\ &= S \left(\frac{\pi}{4} d^2 \times \frac{d}{4} \right) = S \frac{\pi}{16} d^3 \end{aligned}$$

$S \frac{\pi}{16} d^3$ is the total shearing moment, when S is a constant quantity for any given material, and π and 16 are also constants.

$$\therefore P \times R \text{ varies as } d^3.$$

At the instant of rupture the *strength* of the shaft just balances or is equal to the twisting moment $P \cdot R$.

$$\therefore \text{The strength of the shaft varies as } d^3.$$

Example—A good wrought iron shaft 1" diameter has been found to withstand a tongue ($P \cdot R$) of 800 foot pounds. What force acting at the circumference of a pulley 20" diameter will break a shaft of the same material 2" diameter ?

$$\text{Let } T_1 = P_1 \times R_1 = 800 \text{ ft. pds.}$$

$$T_2 = P_2 \times R_2 = P_2 \times \frac{10'}{12}$$

$$\therefore P_1 R_1 : P_2 R_2 :: D_1^3 : D_2^3$$

$$\text{From which we get } P_1 R_1 \times D_2^3 = P_2 R_2 \times D_1^3$$

$$\text{Or } P_2 = \frac{P_1 R_1 \times D_2^3}{R_2 \times D_1^3} = 7680 \text{ lbs.}$$

POWER TRANSMITTED BY SHAFTING.

The amount of power that a shaft will transmit safely is directly proportional to the speed at which it is driven ; thus, a shaft that will transmit 6 H.P. at 50 revolutions per minute will transmit 12 H.P. equally safe at 100 revolutions, and so on. The amount of work performed is obtained by multiplying the force exerted by the space through which it is exerted, and therefore if the space varies the power transmitted or work done must vary to the same extent.

Example—If a 3" shaft transmits 20 H.P. safely at 100 revolutions per minute, what H.P. may be transmitted by a 4" shaft running at 80 revolutions per minute ?

$$\text{Formula, } D_1^3 \cdot R_1 \times P_2 = D_2^3 R_2 P_1$$

when D_1, D_2 represents the diameters of 1st and 2nd shafts respectively, $R_1 R_2$ represents the revolutions per minute of 1st and 2nd shafts respectively ; $P_1 P_2$ represents the H.P. transmitted by 1st and 2nd shafts respectively.

$$\text{From which we get } P_2 = \frac{D_2^3 R_2 P_1}{D_1^3 R_1} = 37.926 \text{ H.P.}$$

Example—Find the H.P. that can be transmitted by a good

wrought iron shaft 4" diameter, when driven by a wheel 3' diameter running at 100 revolutions per minute. The shaft is not to be strained above $\frac{1}{10}$ of its ultimate strength, *i.e.*, factor of safety is 10. The maximum or rupturing twisting moment that a 1" shaft will withstand is 800 ft. pds. Ans.—97.48 H.P.

The following table shows the power that steel shafting will transmit :

	Diameter of shafts in inches.											
	1½	2	2½	3	3½	4	5	6	7	8	9	10
Revs. per min'te	Horse power they will transmit.											
50	3.3	8.0	15.6	27	43	64	125	216	343	512	729	1000
60	4.0	9.6	18.8	32	51	77	150	259	412	614	875	1200
70	4.7	11.2	21.9	38	60	89	175	302	480	717	1021	1400
80	5.4	12.8	25.0	43	69	102	200	346	549	819	1166	1600
90	6.0	14.4	28.1	49	77	115	225	389	617	922	1312	1800
100	6.7	16.0	31.2	54	86	128	250	432	686	1024	1458	2000
110	7.4	17.6	34.4	59	94	141	275	475	755	1126	1604	2200
120	8.1	19.2	37.5	65	103	154	300	518	823	1229	1750	2400
130	8.7	20.8	40.6	70	111	166	325	562	892	1331	1895	2600
140	9.4	22.4	43.8	76	120	179	350	605	960	1434	2041	2800
150	10.1	24.0	46.9	81	129	192	375	648	1029	1536	2187	3000
160	10.8	25.6	50.0	86	137	205	400	691	1097	1638	2333	3200
170	11.5	27.2	53.1	92	146	218	425	734	1166	1741	2479	3400
180	12.2	28.8	56.3	97	154	230	450	778	1235	1843	2624	3600
190	12.8	30.4	59.4	103	163	243	475	821	1303	1945	2770	3800
200	13.5	32.0	62.5	108	172	256	500	864	1372	2048	2916	4000
225	15.2	36.6	70.3	122	193	288	563	972	1543	2304	3280	4500
250	16.9	40.0	78.1	135	214	320	625	1080	1715	2560	3645	5000
275	18.6	44.0	85.9	149	236	352	688	1188	1886	2816	4009	5500
300	20.3	48.0	93.7	162	257	384	750	1296	2058	3072	4374	6000
325	21.9	52.0	101.6	176	279	416	813	1404	2229	3328	4739	6500
350	23.6	56.0	109.4	189	300	448	875	1512	2401	3584	5103	7000
400	27.0	64.0	125.0	216	343	512	1000	1728	2744	4096	5832	8000
450	30.4	72.0	140.6	243	386	576	1125	1944	3087	4608	6562	9000
500	33.7	80.0	156.2	270	429	640	1250	2160	3430	5120	7290	10000

Take 70% of the above powers for wrought-iron shafts.

SIZE OF PULLEYS.

- Let D = driving pulley
- d = driven pulley
- R = No. of revs. per minute of driver
- r = No. of revs. per minute of driven

To Find the Size of the Driving Pulley—

RULE: Multiply the diameter of the driven by the number of its revolutions, and divide by the revolutions of the driver.

$$\text{Formula, } D = \frac{d \cdot r}{R}$$

To Find the No. of Revolutions of Driver—

RULE: Multiply the diameter of the driven by the number of its revolutions, and divide by the diameter of the driver.

$$\text{Formula, } R = \frac{d \cdot r}{D}$$

To Find the Size of the Driven Pulley—

RULE: Multiply the diameter of the driver by its revolutions, and divide by the revolutions of the driven.

$$\text{Formula, } d = \frac{D \cdot R}{r}$$

To Find the Revolutions of the Driven Pulley.

RULE: Multiply the diameter of the driver by its revolutions, and divide by the diameter of the driven pulley.

$$\text{Formula, } r = \frac{D \cdot R}{d}$$

To Find the Value of a Train of Gears or Pulleys—

Multiply the radii, diameters, or number of teeth of all the drivers, and divide by the product of all the radii, diameters, or number of teeth of the followers.

Note—The value of a train is the ratio of the number of revolutions of the last wheel in a train to the number of revolutions of the first wheel in the same train.

Example—Find the value of the following train: The drivers are *A C E*, having respectively 40, 60, 80 teeth; the followers are *B D F*, having 100, 120, 160 teeth. If *F* makes 40 revolutions per minute, how many revolutions does *A* make? 4.8, 192.

SCREW CUTTING.

Let t = Threads per inch to be cut
 T = " " " on leading screw
 $d_1 d_2$ = Number of teeth in drivers
 $f_1 f_2$ = " " " " followers.

The number of threads per inch are inversely proportional to the distance between any two consecutive threads.

$$\frac{t}{T} = \frac{f_1 \times f_2}{d_1 \times d_2} = \frac{\text{pitch of leading screw}}{\text{pitch of screw to be cut.}}$$

If the train of wheels is a simple one, we have

$$\frac{t}{T} = \frac{f}{d} \text{ from which we get}$$

$$t = \frac{f \cdot T}{d} \text{ or the number of threads per inch to be}$$

cut is equal to threads per inch on leading screw multiplied by the

number of teeth in follower divided by the number of teeth in the driver.

By transposition we get $f = \frac{t \cdot d}{7}$ or

To Find the Number of Teeth in the Follower—

RULE: Divide the product of the number of threads to be cut per inch and the number of teeth in the driver by the number of threads per inch on the leading screw.

Example I.—Calculate the number of teeth to be put on leading screw in order to cut 12 threads per inch, when the pitch of the leading screw is $\frac{1}{4}$ " and the driver on lathe spindle has 40 teeth. Ans.—120 teeth.

Example II.—Screw to be cut to have 40 threads per inch. Leading screw $\frac{1}{4}$ " pitch, and using a driver d_1 of 20 teeth, determine the rest of the gears.

$$\frac{t}{T} = \frac{f_1 \times f_2}{d_1 \times d_2} = \frac{40}{4} = \frac{4 \times 10}{1 \times 4} = \frac{80 \times 100}{20 \times 40}$$

$$\therefore \frac{f_1 \times f_2}{d_1 \times d_2} = \frac{80 \times 100}{20 \times 40}$$

The wheels required are therefore $f_1 = 80$ teeth, $f_2 = 100$, $d_2 = 40$ teeth.

Example I.—Leading screw $\frac{1}{2}$ " pitch. Screw to be cut $\frac{1}{4}$ " pitch. What wheels would you use? Ans.—50 driving a 20, or in that ratio.

Example II.—The set of change wheels belonging to a lathe consists of the following:—20, 25, 30, 35, 40, 45, 50, 60, 70, 80, 90, 100, 110 and 120 teeth. If the pitch of the leading screw is $\frac{1}{4}$ " devise suitable trains to cut the following screws and make a table of your results:—4, $4\frac{1}{2}$, 5, $5\frac{1}{2}$, 6, $6\frac{1}{2}$, 7, 8, 9, 10, 12, 14 and 16 threads per inch.

THE PENDULUM.

The time of a single small oscillation is the same time as that of a body falling through half the length of the pendulum multiplied by

π . But the space traversed by a body = $\frac{t^2 g}{2}$. See formula for falling bodies.

$$\text{or } t^2 = \frac{2s}{g}$$

$$\therefore t = \frac{\sqrt{2s}}{g}$$

But the length of the pendulum = $2s$.

$$\therefore t = \frac{\sqrt{l}}{g}$$

Therefore, the time T of a single small vibration = $\pi \frac{\sqrt{l}}{g}$, or

the time is proportional to the square root of the length of the pendulum while g remains constant.

To Determine the Force of Gravity —

From the Formula $T = \pi \frac{\sqrt{l}}{g}$ we get

$$g = \frac{\pi^2 l}{T^2}, \text{ and if } T \text{ is taken as 1 second}$$

then $g = 9.87l$ when l is the length of the pendulum in feet.

If a pendulum 39.15" long oscillates once in a second, find the value of g ; *i.e.* the acceleration due to gravity.

$$\begin{aligned} g &= 9.87l \\ &= \frac{9.87 \times 39.15}{12} = 32.2 \text{ feet.} \end{aligned}$$

THE PENDULUM GOVERNOR.

Let t = time of one revolution

$\frac{Wv^2}{gr}$ = centrifugal force

h = height of the cone

r = radius

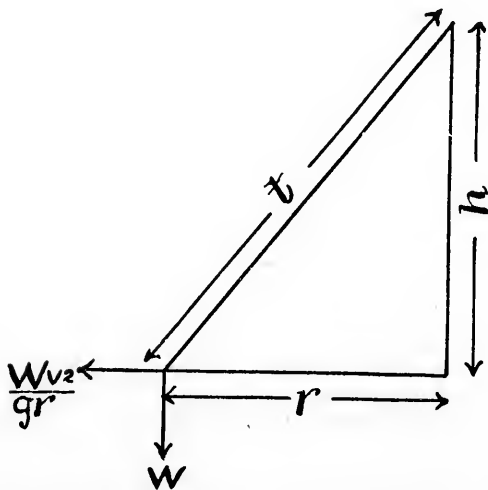

Suppose the governor for the time being to be as shown by the

pendu-
diagram, then by the principle of moments we have

$$\frac{Wv^2}{g^r} \cdot h = Wr$$

$$\therefore h = \frac{g^r}{v^2} \text{ or } \frac{h}{g} = \frac{r^2}{v^2}$$

$$\therefore \frac{\sqrt{h}}{g} = \frac{r}{v}$$

dulum
The velocity = $\frac{2\pi r}{t}$ or $t = \frac{2\pi r}{v}$

and the
but $\frac{\sqrt{h}}{g} = \frac{r}{v}$, and multiply both sides of the equation by 2π .

we get $2\pi \frac{\sqrt{h}}{g} = \frac{2\pi r}{v}$ = time of one revolution, which shows that the time of one revolution varies directly as the square of the height of cone h .

The equation as given for the pendulum is $T = \pi \frac{\sqrt{l}}{g}$, and for the pendulum governor $t = 2\pi \frac{\sqrt{h}}{g}$, which shows that the time of one revolution of the governor is equal to one double swing of the pendulum.

Example I.—What length of pendulum, in inches, will oscillate once in a second in London.

$$t = \pi \frac{\sqrt{l}}{g} = 39.15''$$

Example II.—What is the height of the cone of a governor that will make 30 revolutions per minute?

$$t = 2\pi \frac{\sqrt{h}}{g}$$

$$t_2 = \frac{4\pi^2 h}{g^2}$$

$$\therefore h = \frac{t^2 g}{4\pi^2} = \frac{g}{\pi^2} = 39.15''$$

which is the same as the pendulum that beats seconds.

To Find the Height of a Revolving Pendulum which makes a given number of revolutions per second—

$$\text{Formula, } h = \frac{g}{4\pi^2} \div \text{Revolutions per second squared}$$

$$= \frac{9.78''}{\text{Revs. per second}^2}$$

Example—What is the height in inches of the cone of a pendulum governor making 120 revolutions per minute? Ans.—2.445''

ACCELERATION DUE TO GRAVITY.

Let t = time in seconds
 g = measure of acceleration
 s = space traversed
 u = initial velocity at beginning of interval of time
 v = final " " end " " " " "
 $v - u$ = change of velocity in t units
 $\frac{v - u}{t}$ = rate of change of velocity = g

$$v = u + gt \quad (1)$$

• Average $v = \frac{u + v}{2}$

Space = average velocity \times No. of seconds

$$= \left(\frac{u + v}{2} \right) t \quad (2)$$

$$= \left(\frac{u + u + gt}{2} \right) t = ut + \frac{gt^2}{2} \quad (3)$$

If $u = 0$ or body starts from rest, the

$$\text{Space} = \frac{gt^2}{2}$$

In equation (1) $v = u + gt$

$$\therefore t = \frac{v - u}{g} \text{ and if we substitute this value of } t \text{ in equa-}$$

tion (2) we get $s = \frac{v^2 - u^2}{2g}$ from which we get

$$v^2 = u^2 + 2gs \quad (4)$$

and if $u = 0$ then $v^2 = 2gs$

$$v = \sqrt{2gs} \quad (5)$$

When a body is thrown vertically upward with an initial velocity u , to find the space and velocity v at the end of time t ; g in this case, is opposite to the motion of the body:

$$\therefore v = u - gt \quad (6)$$

$$s = ut - \frac{gt^2}{2} \quad (7)$$

To find the time, t , to reach a given height, s , when thrown with a velocity, u , and also the velocity, v , at a given height:

From equation (7), we get

$$t = \frac{u \pm \sqrt{u^2 - 2gt}}{g} \quad (8)$$

Both values of t are positive. The lesser gives the time required by the body to reach the given point, and the greater the time required by it to come to rest and fall back to this point.

Substitute in equation (4) $-g$ for g , and we can find the velocity at a given height :

$$v^2 = u^2 - 2gs$$

$$v = \sqrt{u^2 - 2gs}$$

when s = height.

Examples—Body thrown vertically downward with a velocity of 50' per second. Find the velocity at the end of 15 seconds and when it has fallen 600'. Ans.—530' ; 247'.

A body is thrown upward with a velocity of 160' per second. Find the velocity at the end of 3 seconds, and also when it has risen 400'. Ans.—64' ; 0'.

A body falls from rest for 4 seconds. Find the distance fallen, and also the distance fallen in the 4th second. Ans.—144' ; 112'.

Body projected vertically upward at an initial velocity of 160' per second. Find distance traversed in 5 seconds, and also the distance traversed in the 5th second. Ans.—400' ; 16'.

How to Proceed to Set Up a Stationary Engine.

Having come to a decision as to the proper position to place the engine, drop a plumb line from several points on the line shaft to the floor, strike a line on the floor under shaft to correspond with the plumb lines and locate where the centre line of engine is to be—being sure that it is at right angles to the line already on the floor ; the best method to adopt to get the two lines at right angles to each other, is fully illustrated by the 47th problem of Euclid, "The sum of the squares of two sides of a right angle triangle is equal to the square on the hypotenuse" :

The square of A added to the square of B is equal to the square of C , as illustrated by Fig. 1 ; to apply this, measure off on the line under line shaft 12' from the point where the centre line of engine crosses it and from the same point measure off 16' on the centre line of engine, the 16' point is to be moved sideways until it is exactly 20' from the 12' point on centre line under line shaft, then stretch a line from the point where the lines cross each other,

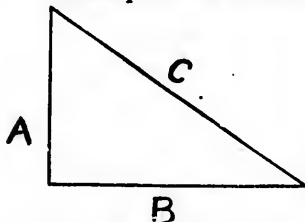

FIG. 1.

directly over the 16' point, the two lines will then be exactly at right angles to each other ; if there is not room to use the distances 12', 16' and 20', use 6', 8' and 10', but it is best to use the first, as with this any slight deviation would only be one-half as much as it would be with the last. To get the position of outer bearing and have it square with centre line of engine, proceed as before ; or, measure from the centre line under line shaft at two different points to get the crank shaft of engine parallel with this line. The excavation for foundation and pier of outer bearing can now be made—it should be 2' or 3' wider and longer than the intended foundation. When the excavation is finished, the templet for the anchor bolts may be set ; care should be taken that the centre line on templet is directly under the line representing centre line of engine. If the bolts are to be

built in, they can be hung in temple, but the best practice is to have hand-holes in bottom of foundation, in which case drop plumb lines through holes in temple and lay off the hand-holes 12" wide, and when the foundation is built up 12" from bottom, lay oak plank 3" or 4" thick, of sufficient length to reach over the two hand-holes; when this is in position, again drop the plumb line and bore holes in the plank $\frac{1}{2}$ " larger than the anchor bolts; the holes in foundation from oak plank to top of rubble stone or brick work can be left by using a taper stick or piece of pipe or square wooden box; the size of holes will depend on the size of bolts required, but should be 1" or even more larger than the bolts. Should the taper sticks be used, care should be taken to turn them occasionally to prevent the cement adhering to them; in any case, the foundation should be built with Portland cement and good clean sharp sand: if bricks are used, they should be dipped in water before being laid. The depth and weight of foundation will depend on the size and weight of engine; if the bottom on which the foundation is to be built is very soft, there should be 18" or 24" of concrete (broken stone and cement), put in on which the foundation should rest; the base of foundation should be wider and longer than the top, that is, with a batter on the side of walls about $1\frac{1}{2}$ " to the foot in height. When the top stones are laid, care should be taken that they are perfectly level on top and the cement used under these stones slightly stronger than the other part of foundation. As soon as they are placed in position, the engine can be placed and lined up; to do which, in most cases it is best to remove the piston and pass a line through cylinder, taking great care that the line is in the centre of cylinder at back end and the centre of stuffing box at front end also passes over the centre of crank pin; by turning the crank shaft and adjusting outer bearing so that the centre of crank pin is directly over the line at both back and forward centres, the shaft will be at right angles with centre line of engine. The adjustment of engine and outer bearing, to get them level, should be done with iron wedges and when in proper position and the fly-wheel on shaft, sulphur may be run under engine frame cylinder and stand for outer bearing, the anchor bolts tightened, piston put in cylinder and connections made. There are several more details that might be mentioned, but they would not apply to every case, but as they occur, the engineer in charge of erecting should be prepared to meet them.

To Set Up a Wheelock Engine.

After the engine is placed on foundation, level the frame lengthwise by placing a level on lower guide and level it the other way by dropping a plumb line over the four high points left on the frame in front of guides for this purpose, place one thickness of paper between the line and the two points on upper guide, this will enable the man doing the job to see how close the line is to the high point on lower guide, and when right the engine will be level both ways. Place the level in the main bearing, the levelling should be done with wedges under cylinder and crank end of frame. The stand and outer bearing can now be placed and the crank shaft put in position; the stand adjusted with wedges until shaft is level. To line up the engine, make line fast to centre of crosshead pin and pass it forward half length of

crank pin from face of crank, turn shaft to back and forward centre to see that it is at right angles with centre line of cylinder; fly-wheel can then be placed in position on shaft, keyed up and allowed to stand a few hours while making steam connections, then try the shaft and frame again to see that they are level and that the foundation has not settled, and if all right run sulphur under cylinder, crank end of frame and stand for outer bearing, tighten the foundation bolts, put on connection rod, finish steam and exhaust connections then engine is ready to start. Should the valves need adjusting, look on the face of arms on cut-off valves for small marks for this purpose.

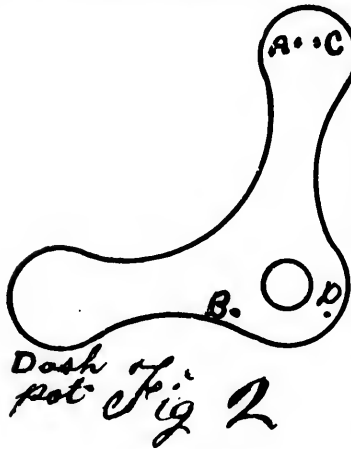

When the valves are at rest a fine plumb line should drop directly over the points *A* and *B*, Fig. 2; should this not be right, it can be made so by loosening the set screw which holds the stud on which the dash pot rests, the end of this stud is eccentric, so by turning it the dash pot can be lowered or raised as the case may require; when right, be sure to tighten set screw. In order to get the lead point, place the crank on the forward or back centre, as the case may be, being careful that it is correct and the hook holding the valve in position, a fine plumb line should fall directly over the points *C* and *D*, Fig. 2. If

after indicating the engine the diagrams show that the load is not equally divided between both ends of cylinder, the rod between the two trips should be lengthened or shortened as the case might require. In starting the engine for regular work, it would be well to allow an extra quantity of cylinder oil to pass through lubricator for at least a week after, by this means the piston and inside of cylinder will become polished and be less liable to cut.

RIVETTED JOINTS.

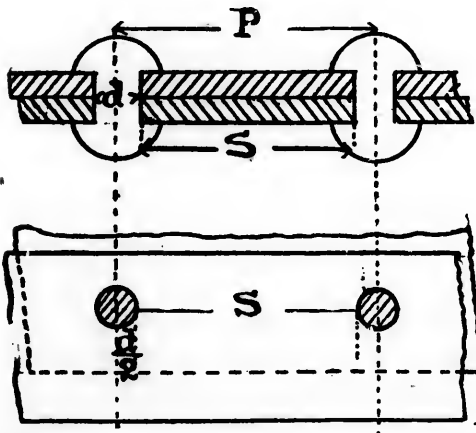

Let P = pitch of Rivets in ins.

d = diam. " "

t = thickness of Plate "

T_s = Tensile strength of Plate per sq. in.

S_s = Shearing strength of Plate per sq. in.

n = No. of rows of Rivets.

The strength of the plate between rivet centres is $= P \times t \times Ts$. If at the ends of the line, P , two holes are drilled d'' in diameter, the plate is diminished by two halves of one diameter or one diameter, *i.e.*, $P-d=s$, which represents the available section, and the strength becomes $(P-d) t \times Ts$, obviously less than $P \times t \times Ts$.

The ratio of the strength of the plate, after the holes are drilled, to that of the original plate will be represented by $\frac{(P-d) t \times Ts}{P.t.Ts}$ and the percentage of the strength of the plate will be $\frac{(P-d) 100}{P}$. From this follows the

RULE for finding the percentage of strength of plate after the holes are drilled: Divide 100 times the difference between the pitch and the diameter of the rivet by the pitch.

Example—Pitch of rivets, $2\frac{1}{4}''$; diam. of rivet $=\frac{3}{4}''$. Ans.—70%.

The shearing strength of a rivet = Area of rivet \times Shearing strength; and if there are, n , rows of rivets, then

Area of rivet $\times Ss \times n =$ Shearing strength of n rivets.

But $P.t.Ts =$ original strength of plate.

$$\therefore \frac{\text{Area of rivet} \times Ss \times n}{P.t.Ts} = \text{Ratio of strength of rivets to that of original plate.}$$

$$\text{or } \frac{\text{Area of rivet} \times Ss \times n \times 100}{P.t \times Ts} = \% \text{ strength of seam.}$$

And if we assume $Tt = Ss$, then

$$\frac{\text{Area of rivet} \times n \times 100}{P.t} = \% \text{ strength of seam to that of original plate.}$$

Example—Thickness of plate, $\frac{3}{4}''$; rivets, $1\frac{1}{8}''$ diam.; pitch, $3\frac{3}{4}''$. If seam is double rivetted, find the percentage of strength of rivets to that of original plate. Ans.—71%.

The most economical form of a joint is one in which the plate and rivet strengths are just equal, and the best way to arrive at this is to equate the formula for the rivet section to that of the plate section, thus:

$$\frac{\text{Area of Rivet} \times \text{No. of Rows of Rivets}}{P.t} = \frac{P-d}{P}$$

$$\text{or } (P-d) Pt = \text{Area of rivets} \times n \times P.$$

$$\text{from which we get } (P-d)t = \text{Area of Rivets} \times n$$

$$\text{or } P = \frac{\text{Area} \times n}{t} + d \quad (1)$$

To Find the Pitch of Rivets if all the other data is given—

Multiply the area of the rivet by the number of rows of rivets, then divide by the thickness of the plate and add the diameter of the rivet to the quotient.

If thickness of plate is required, then

$$t = \frac{\text{Area of Rivet} \times n}{P - d} \quad (2)$$

To Find the Area of the Rivet—

$$\frac{(P - d) t}{n} = \text{area} \quad (3)$$

or if area of rivets is given to find the number of rows

$$n = \frac{(P - d) t}{\text{area}} \quad (4)$$

As it is more practical to take the diameter instead of the area of the rivets the formulæ would have to be changed, as follows:

$$\text{Formula (1) becoming } P = \frac{d^2 \times .7854 \times n}{t} + d \quad (5)$$

$$(2) \quad " \quad t = \frac{d^2 \times .7854 \times n}{P - d} \quad (6)$$

$$(3) \quad " \quad d = \sqrt{\frac{(P - d) t}{.7854 \times n}} \quad (7)$$

$$(4) \quad " \quad n = \frac{(P - d) t}{d^2 \times .7854} = \frac{(P - d) t \times 1.273}{d^2} \quad (8)$$

Examples—Find the pitch of the rivets so as to secure an equal percentage of strength in rivets and plate of a double rivetted seam plate $\frac{3}{4}$ " rivets- $1\frac{1}{8}$ " diameter. Ans.—3.775"

Pitch 3.775", plate $\frac{3}{4}$ " seam double rivetted. Find area and diameter of rivet.

Take formula (3) when area = $\frac{(P - d) t}{n}$ we get .994 sq. inches, and from (7) we get

$$\begin{aligned} \text{Diameter of rivet} &= \sqrt{\frac{(P - d) t}{.7854 \times n}} = \sqrt{\frac{(3.775 - 1.125) \frac{3}{4}}{.7854 \times 2}} = \sqrt{\frac{3.975}{3.1416}} \\ &= \sqrt{1.2652} = 1.125" \text{ or } 1\frac{1}{8}" \end{aligned}$$

To prove that this joint is correct, all that is necessary is to find the percentage of strength of the plates after the holes are drilled to that of the original plate, and also the shearing strength of the rivets to that of the original plate; or,

$$\frac{P - d}{P} = 70\% \text{ in the above example;}$$

$$\text{or } \frac{D^2 \times .7854 \times n}{P \cdot t} = \frac{\text{Area of rivet} \times n}{P \cdot t} = 70\%$$

Professor Unwin gives the diameter of the rivet as being = $1.2\sqrt{t}$, and which is considered a very good proportion; and from this we can easily calculate the pitch and diameter of the rivet, if the thickness of the plate is known.

Example—Plate, $\frac{3}{4}$ " thick. Find P and d in a single rivetted lap joint.

The diameter of the rivet is found to be 1.044", and by formula (1) we get the pitch to be 2.445".

The percentage of strength of rivets in a single rivetted lap joint compared with that of the original plate =

$$\frac{\text{Area of rivet} \times n \times 100}{P \times t} = \frac{.994 \times 100}{2.445 \times \frac{3}{4}} = 54\%$$

and the strength of the plate after holes are drilled to that of the original plate is $\frac{P-d}{P} = 54\%$

∴ The strength of a single rivetted lap joint is only 54% of the original plate.

Example in Double Rivetted Joint—Plate, $\frac{3}{4}$ " thick. Find pitch and diameter of rivets; also, percentage of strength of joint to that of the original plate.

The diam. of the rivets is the same as in the single rivets, viz. = $1.2\sqrt{t} = 1\frac{1}{8}$ " nearly; and P will be found to be 3.795", in practice $3\frac{3}{4}$ ".

If the joint is properly designed, the strength of the rivet section will be equal to that of the plate section, and in this instance it will be found that the strength of the rivet section is .7 of the original plate. From this, we find that the strength of a double rivetted lap joint is 70% of the original plate.

Tripple Rivetted Lap Joint—

Example—Plate $\frac{3}{4}$ " thick. Find pitch, diameter of rivet, and also percentage of strength of joint. The diameter is the same as in the single and double rivetted joints, viz., 1.044", and by formula (1) we get $P=5.0'$. By calculating the strength of the joint as above indicated we get it to be close on to 80%. Therefore the strength of a tripple rivetted lap joint is 80% of the original plate.

The following is a summary of the above :

The strength of plate between rivet centres = $P.t.Ts$.

The percentage of strength of plate after holes are drilled = $\frac{(P-d)100}{P}$

The shearing strength of a rivet is = Area of rivet $\times Ss$. The percentage of strength of rivet section of n Rows to that of original plate

$$\text{is} = \frac{\text{Area of rivet} \times Ss \times n \times 100}{P.t.Ts} = \frac{\text{Area of rivet} \times n \times 100}{P.t}$$

if shearing and tensile strength are equal.

$$\text{The pitch is} = \frac{\text{Area of rivet} \times n}{t} + d.$$

Single rivetted lap joint is .54 of the solid plate.

Double " " " is .70 " " "

Tripple " " " is .80 " " "

STRENGTH OF BOILER SHELLS.

The question of the form of boiler was unimportant while very low pressures were used, but as soon as the higher pressures from 40 lbs. per square inch and upwards were adopted it became necessary to devote considerable attention to the form of shell that would best withstand internal pressure.

The sphere is the strongest form for any boiler, but owing to many reasons for not adopting this in practice the cylindrical boiler is universally used as being the nearest approach to the sphere.

The force tending to rupture a boiler is = the pressure per square inch \times by the diameter in inches, and is arrived at in the following manner:

Let P = bursting pressure per square inch
 t = thickness of plate in inches
 D = diameter in inches
 T_s = tensile strength of the material.

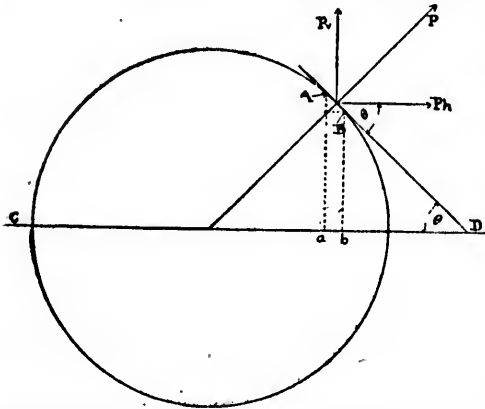

In the diagram take the small surface AB which lies at the angle Θ with the line CD .

By the resolution of forces the bursting pressure P on surface AB can be resolved into two components, viz.: Pv and Ph , which are the vertical and horizontal components.

$$Pv = P \cos \Theta$$

The vertical pressure on $AB = AB \cdot P \cos \Theta$, and $\cos \Theta \cdot AB = ab$.

From this we see that the vertical pressure on the surface $AB = P \cdot ab$, and as the sum of all the vertical components of P will be $= P \times$ diameter.

If the boiler has a length l we have a pressure tending to cause rupture $= P \cdot D \cdot l$. and we have resisting this pressure $2t \cdot l \cdot T_s$. and therefore at the point of rupture the resistance of the material = pressure tending to cause rupture.

From this we get $P \cdot D \cdot l = 2t \cdot l \cdot T_s$

$$P D = 2t \cdot T_s$$

$$P = \frac{2t \cdot T_s}{D}$$

(1)

$$\therefore t = \frac{P \cdot D}{2 T_s}$$

We see from this that the pressure P required to cause longitudinal rupture is equal to twice the thickness of the plate multiplied by the tensile strength of the material divided by the diameter of the boiler in inches. The boiler may also be ruptured transversely due to the pressure on the ends. In this case the force tending to cause

rupture = pressure \times area of boiler (cross section) *i.e.*, $P \times D^2 \cdot 7854$
and the resistance of the plate = area $\times T_s$ at the point of rupture.

$$P \cdot D^2 \frac{\pi}{4} = \pi D \cdot t \cdot T_s$$

$$P = \frac{4t \cdot T_s}{D} \quad (2)$$

From (1) and (2) we see that the pressure causing rupture longitudinally is one-half that causing rupture transversely, or

$$\frac{P}{P} = \frac{2t \cdot T_s}{\frac{4t \cdot T_s}{D}} = \frac{1}{2}$$

and for this reason the longitudinal seams are always made stronger than the circumferential seams.

In boilers having internal flues the pressure required to rupture a boiler transversely is greater than twice that for the longitudinal rupture for the area exposed to pressure is less than the whole cross section of the boiler by the area of the flues.

Example—A boiler 28' long, 7' diameter, has two 30" internal flues running the whole length of the boiler, the thickness of the plate is $\frac{3}{8}$ ". The longitudinal seams are double rivetted and the transverse seams single rivetted. Find the bursting pressure along the longitudinal and transverse sections. Tensile strength of plate 50,000 lbs. square inch. Ans.—417 lbs. 1534 lbs.

STAYS.

To Find the Strain on Each Stay—

RULE: Find area of surface supported, and multiply it by pressure carried, and divide it by the number of stays, and the quotient will be the strain on each stay.

To Find the Proper Diameter of Stay—

RULE: Strain on one stay divided by 5000 (which is the strain allowed per sq. in. of stay), then divide by .7854, and extract the square root, will give the diameter required.

To Find the Proper Pitch of Stays—

RULE: Strain on one stay, divided by steam pressure to be carried, and extract the square root, will give the proper pitch of stays.

To Find the Total Amount of Stays in Square Inches Necessary—

RULE: Area of sheet to be stayed, multiplied by pressure to be carried, divided by 5000.

Knowing pitch of stays and steam pressure, to Find Strain on One Stay—

RULE: Pitch squared and multiplied by pressure = strain on one stay.

To Calculate the Area of a Diagonal Stay—

RULE: First find the area of a direct stay sufficient to support

the surface to be stayed, then the area of direct stay, multiplied by the length of diagonal stay, and divide the product by the length of a line drawn at right angles from the surface to be stayed to the point where diagonal stay is secured. Thus—

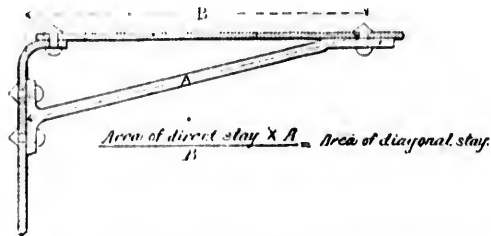

WATER AT DIFFERENT TEMPERATURES.

The component parts of water by weight and by measure are—

	By Weight.	By Measure.
Oxygen	88.9	1
Hydrogen	11.1	2

One cubic inch of water at its maximum density, 39.1° F., weighs 252.6937 grains, and one cubic foot weighs 62.425 lbs.; it is 828.5 times heavier than atmospheric air.

The four notable temperatures are— 1. Freezing point, 32° F.; 2. Maximum density, 39.1° F.; 3. Standard of specific gravity, 62° F.; 4. Boiling point at sea level, 212° F.

Below 39.1° it decreases in density very slowly at first, and very rapidly as it nears the point of congelation. A cubic foot of ice weighs 57.25 lbs. and expands $.089 = \frac{1}{11.24}$ of its bulk.

	Imperial.	U. S.
One cubic foot of water	6.23 gallons. 1728 cubic inches. 62.4 lbs.	7½ gallons.
One gallon of water...	277.274 cubic ins. 10 lbs.	231 cubic inches. 8½ lbs.

It has the greatest solvent power of any of the liquids; for common salt this is constant for all temperatures. For other matter, such as carbonate of lime, magnesium and the different sulphates, its solvent power increases as the temperature increases. It decreases in weight as the temperature increases—

At 32° F.,	weight per cubic foot	62.418 lbs.
“ 39.1° F.,	“	62.425 “
“ 62° F.,	“	62.355 “
“ 212° F.,	“	59.760 “

Water is practically incompressible, and its capacity for absorbing heat is greater than any other liquid or solid.

The following table gives the heat units per lb. and the weight of a cubic foot of water at temperatures from 32° to 212° F.:

Temp. Fah.	Heat units per lb.	Weight per cubic ft.	Temp. Fah.	Heat units per lb.	Weight per cubic ft.	Temp. Fah.	Heat units per lbs.	Weight per cubic ft.
32°	0.00	62.42	114	82.02	61.83	154	122.34	61.10
35	3.02	62.42	115	83.02	61.82	155	123.34	61.08
40	8.06	62.42	116	84.03	61.80	156	124.35	61.06
45	13.08	62.42	117	85.04	61.78	157	125.36	61.04
50	18.10	62.41	118	86.05	61.77	158	126.37	61.02
52	20.11	62.40	119	87.06	61.75	159	127.38	61.00
54	22.11	62.40	120	88.06	61.74	160	128.38	60.98
56	24.11	62.39	121	89.07	61.72	161	129.39	60.96
58	26.12	62.38	122	90.08	61.70	162	130.40	60.94
60	28.12	62.37	123	91.09	61.68	163	131.41	60.92
62	30.12	62.36	124	92.10	61.67	164	132.42	60.90
64	32.12	62.35	125	93.10	61.65	165	133.42	60.87
66	34.12	62.34	126	94.11	61.63	166	134.43	60.85
68	36.12	62.33	127	95.12	61.61	167	135.44	60.83
70	38.11	62.31	128	96.13	61.60	168	136.45	60.81
72	40.11	62.30	129	97.14	61.58	169	137.46	60.79
74	42.11	62.28	130	98.14	61.56	170	138.46	60.77
76	44.11	62.27	131	99.15	61.54	171	139.47	60.75
78	46.10	62.25	132	100.16	61.52	172	140.48	60.73
80	48.09	62.23	133	101.17	61.51	173	141.49	60.70
82	50.08	62.21	134	102.18	61.49	174	142.50	60.68
84	52.07	62.19	135	103.18	61.47	175	143.50	60.66
86	54.06	62.17	136	104.19	61.45	176	144.51	60.64
88	56.05	62.15	137	105.20	61.43	177	145.52	60.62
90	58.04	62.13	138	106.21	61.41	178	146.53	60.59
92	60.03	62.11	139	107.22	61.39	179	147.54	60.57
94	62.02	62.09	140	108.22	61.37	180	148.54	60.55
96	64.01	62.07	141	109.23	61.36	181	149.55	60.53
98	66.01	62.05	142	110.24	61.34	182	150.56	60.50
100	68.01	62.02	143	111.25	61.32	183	151.57	60.48
102	70.00	62.00	144	112.26	61.30	184	152.58	60.46
104	72.00	61.97	145	113.26	61.28	185	153.58	60.42
106	74.00	61.95	146	114.27	61.26	186	154.59	60.41
108	76.00	61.92	147	115.28	61.24	187	155.60	60.39
110	78.00	61.89	148	116.29	61.22	188	156.61	60.37
112	80.00	61.86	149	117.30	61.20	189	157.62	60.34
113	81.01	61.84	150	118.30	61.18	190	158.62	60.32
			151	119.31	61.16	191	159.63	60.29
			152	120.32	61.14	192	160.63	60.27
			153	121.33	61.12	193	161.64	60.25
						194	162.65	60.22
						195	163.66	60.20
						196	164.66	60.17
						197	165.67	60.15
						198	166.68	60.12
						199	167.69	60.10
						200	168.70	60.07
						201	169.70	60.05
						202	170.71	60.02
						203	171.72	60.00
						204	172.73	59.97
						205	173.74	59.95
						206	174.74	59.92
						207	175.75	59.89
						208	176.76	59.87
						209	177.77	59.84
						210	178.78	59.82
						211	179.78	59.74
						212	180.79	59.76

Mechanical Refrigeration and Ice Making.

In order to arrive at a clear understanding as to what processes of nature are applied in refrigerating and ice-making machines, attention is called to certain facts well-known by everybody. If, especially on a warm and dry summer day, the hand is moistened with water and then exposed to a current of air, a decided sensation of cooling will be noticed. The dryer the air and stronger the current, the more will be the cooling effect. The explanation of this phenomenon is that by the rapid circulation of air over the wet hand the water is evaporated, and that for this evaporation it needs heat, which is to a great extent taken from the warm hand and therefore produces the cooling effect upon the skin. If instead of water the hand is moistened with alcohol the cooling effect will be still greater because alcohol is so much more volatile than water, and if sulphuric ether is used for this experiment the effect will be still more marked. The heat which is required to transform a liquid into a gas is called the "latent" heat. What becomes of the heat which is constantly supplied to boiling water? The answer to this is that it is used to change the liquid condition of the water into that of gas or vapor, and the heat supplied in this manner not showing any increase on the thermometer must be contained in the vapor. It appears again if the vapors are condensed into a liquid, and this proves that while the water was in the vaporous state the heat contained in it to maintain it in that condition has become "latent."

This physical law of nature is made use of in nearly all the machines which have for their object the reduction of temperatures. If the substances which we are in the habit of using for this purpose were to cost nothing, we could simply let the evaporated agents, such as ammonia, carbonic acid, sulphuric ether, or dioxide of sulphur, escape into the atmosphere. But since the substances are rather costly, it becomes a matter of necessity for the purpose of economical refrigeration to maintain them in the apparatus which is used for the purpose of cooling or ice-making, and all the cumbersome machinery which is used for the production of cold has really no other object than to restore the refrigerating agent by alternately liquifying it and re-evaporating it. During the process of evaporation it takes up the latent heat from the surrounding bodies and thus cools them, and in the process of condensation this heat is again given off to the cooling water that is showered over the condensers and by it carried away into the thermal ocean. To give an idea how much a pound of ice, or its equivalent in cooling, would cost by using ammonia if it was not retained in the apparatus; it should be stated that the latent heat of water being 142 and the latent heat of ammonia about 560, it would take about one pound of liquid ammonia evaporated to produce the cooling effect of the melting of about 4 pounds of ice ($3\frac{1}{2}$ lbs. in reality counting certain losses). The price of ammonia at 30 cents a pound would make the equivalent of 1 lb. of ice cost $7\frac{1}{2}$ cents or \$1.50 per ton, and this simple calculation proves that it is absolutely necessary to use the refrigerating agent over and over again, and to provide an apparatus which, in the waste of this agent is as economical as possible, or, in other words, have an apparatus which is as nearly perfectly tight as possible.

eight of

Weight
per
cubic ft.

61.10
61.08
61.06
61.04
61.02
61.00
60.98
60.96
60.94
60.92
60.90
60.87
60.85
60.83
60.81
60.79
60.77
60.75
60.73
60.70
60.68
60.66
60.64
60.62
60.59
60.57
60.55
60.53
60.50
60.48
60.46
60.42
60.41
60.39
60.37
60.34
60.32
60.29
60.27
60.25
60.22
60.20
60.17
60.15
60.12
60.10
60.07
60.05
60.02
60.00
9.97
9.95
9.92
9.89
9.87
9.84
9.82
9.74
9.76

Of all the agents to-day used for purposes of cold production ammonia has so far maintained its superiority. Under ordinary temperatures ammonia is a gas, but it can be liquified by compression and cooling. After liquifaction and being exposed in an open vessel to the ordinary pressure of the air, it will boil, at a temperature of 27°F . below zero, which makes it eminently fit for the production of low temperature. It is a non-inflammable substance of absolute stability and will, if contained in an apparatus built entirely of iron or steel, retain its chemical composition for all time. Carbonic acid is also, to a very limited extent, used for the production of cold, but it has not all the excellent qualities which ammonia possesses, especially on account of the enormous pressure necessary to liquify it, and on account of the quality it possesses of not being liquifiable at all above a temperature of about 90°F ., while ammonia can be liquified at a much higher temperature than this. Besides, where condenser pressures in machines using ammonia generally range from 150 to 180 lbs. per square inch, the condenser pressures of the carbonic acid machines lie between 800 and 900 lbs. per square inch; and while the evaporating pressure of the ammonia is generally in the neighborhood of about 25 lbs. per square inch, that of carbonic acid machines is as high as 200 to 250 lbs. per square inch, so that the piping system—cocks, all joints and the compressor—have to be a great deal stronger than is necessary with the use of ammonia.

There are two different systems for the handling of ammonia, one is called the Compression System and the other the Absorption System. The former uses the refrigerating agent in its purest state and entirely free from all watery admixtures, and is, therefore, anhydrous. The Absorption System uses the solution of ammonia in water, and is denominated the Absorption System on account of the final operation by which the evaporated ammonia is regained. In the Absorption machine the ammonia is driven out of its solution in water by being heated by means of a steam coil; and the ammonia thus driven off and carrying along with it a certain percentage of water is condensed in an apparatus called the "Condenser," which is kept cool by water being supplied to the outside surface of the pipes in which the ammonia is forced from the "Still." The liquid ammonia, after being collected in a receiver or storage tank, is passed through a cock into pipe coils, called the "Refrigerator," in which a lower pressure than that of the condenser is maintained. The latter is accomplished by passing the ammonia gas generated in the refrigerator into another vessel, called the "Absorber." In this vessel the gas is again brought into contact with the water from which it had been driven out before by heat, the water before it enters the absorber being cooled down to as low a temperature as the cooling water of Nature will permit. The combination of the ammonia gas and this water again liberates heat, and therefore the absorber has to be kept cool by running water the same as the condenser. The strong solution is now by a little feed pump pumped back into the boiler, or still, and the cycle of operations is started anew.

In the compression system the process is simpler. By the sucking action of the compressor pump the ammonia gas is drawn away

from the refrigerator coils, and is compressed on the return stroke of the piston into the condenser—condenser and refrigerator coils being practically the same as those of the Absorption System. From the condenser to liquified ammonia is likewise passed through a small regulating or expansion cock into the refrigerator, and the cycle of operations here commenced again. It thus appears that there is one less operation during the process through which the ammonia passes, and that is the absorption of the gas.

It is very easily understood now, as the evaporation of the ammonia produces the cold in the refrigerator pipes, that these pipes can be utilized in any manner desired for the cooling of other bodies. They may be put up in a room in which the air is thus directly cooled, or they may be put into a tank with salt brine, which is non-freezable, except at a very low temperature, and by their cold surfaces cool the brine, which in return may be circulated through pipes in a room, and thereby produce a lowering of temperature. The former is called the "Direct Expansion System," and the latter is called the "Brine Circulating System."

PROPERTIES OF AMMONIA.

Temp.deg. Fah.	Gauge press. Lbs. per sq. in.	Heat of vaporization.	Volume of vapor per lb. cub. ft.	Weight of a cub. ft. of vapor in lbs.
40	0	579.67	24.37	.0410
35	0	576.69	21.29	.0467
30	0	573.69	18.66	.0535
25	1.47	570.68	16.41	.0609
20	3.75	567.67	14.48	.0690
15	6.29	564.64	12.81	.0779
10	9.07	561.61	11.36	.0878
5	12.87	558.56	10.12	.0988
0	15.67	555.50	9.04	.1109
5	19.47	552.43	8.06	.1241
10	23.85	549.35	7.23	.1384
15	28.23	546.26	6.49	.1540
20	33.25	543.15	5.84	.1712
25	38.73	540.03	5.26	.1901
30	44.71	536.92	4.75	.2105
35	51.23	533.78	4.31	.2320
40	58.30	530.63	3.91	.2583
45	65.96	527.47	3.56	.2809
50	74.25	524.30	3.25	.3109
55	82.93	521.12	2.96	.3379
60	92.90	517.93	2.70	.3704
65	103.33	514.73	2.48	.4034
70	114.51	511.52	2.27	.4405
75	126.55	508.29	2.08	.4808
80	139.41	504.66	1.91	.5262

If ice is wanted, the cold brine which is produced by the refriger-

ating coils may be used to have immersed in it galvanized iron cans containing pure water; and if the brine is kept at a temperature of, say, 14° or 15° below the freezing-point of water, it is evident that, after more or less time, the water in the can will finally be frozen.

After it is entirely frozen, the can is lifted out and the ice melted out by applying tepid water to the outside of the can. Thus a block of ice is formed of the exact shape of the can.

HORSE-POWER.

The unit of power universally adopted by mechanical engineers in this country is that which was proposed and used by Watt, viz., the *horse-power*. What is technically spoken of among engineers as a *horse-power* is the rate of doing work corresponding to 33,000 foot pounds per minute, and the power of engines is always calculated on this basis.

The horse-power exerted by an engine is = total mean pressure on the piston in pounds multiplied by the distance in feet travelled by the piston in one minute, divided by 33,000.

Let $H.P.$ = Indicated horse-power

N = Number of strokes per minute = Revolutions $\times 2$

L = Length of stroke in feet

A = Area of the cylinder in square inches = $D^2 \times .7854$

P = Mean effective pressure in pounds per square inch.

The mean pressure on the piston is = $P.A$ and the distance travelled in one minute by the piston is = $L.N$

$$\therefore \text{the horse-power of the engine} = \frac{P.L.A.N}{33000} \quad (1)$$

And by transfer—

To find the mean effective pressure when all other data are given :

$$\text{Formula, } P = \frac{H.P. \cdot 33000}{L.A.N} \quad (2)$$

To find the length of stroke in feet :

$$\text{Formula, } L = \frac{H.P. \cdot 33000}{P.A.N} \quad (3)$$

To find the area of the cylinder :

$$\text{Formula, } A = \frac{H.P. \cdot 33000}{P.L.N} \quad (4)$$

To find the diameter of the cylinder :

$$\text{Formula, } D = \frac{\sqrt{H.P. \times 33000}}{P.L.N \times .7854} = \frac{\sqrt{H.P. \times 42000}}{P.L.N} \quad (5)$$

To find the number of revolutions :

$$\text{Formula, No. of revolutions} = \frac{N}{2} = \frac{H.P. \cdot 33000}{P.A.L} \quad (6)$$

Examples—What is the horse-power of an engine running at 300 revolutions per minute 18" stroke, diameter of cylinder 10", and the mean effective pressure 50 lbs.? Ans.—21.42 horse-power.

What is the mean effective pressure in an engine of 120 horse-

power, running at 150 revolutions per minute, 15" diameter of cylinder, and stroke 30". Ans.—30 lbs.

The mean pressure as indicated by a diagram taken from an engine running at 100 revolutions per minute is 45 lbs. per square inch, the area of the cylinder is 100 square inches. Find the length of the stroke if the engine is developing $87\frac{1}{2}$ horse-power. Ans.— $3' 2\frac{1}{2}"$.

What is the diameter of the cylinder of an engine which is running at 300 revolutions per minute, 20" stroke, mean pressure 50 lbs., and indicates 225 horse-power. Ans.—13.75 horse-power.

To Find the Horse-Power of a Compound, Triple, or Quadruple Expansion Engine, calculate by the rule given above the horse-power of each cylinder separately and then add the results.

Note: Treat each cylinder as if it were a separate engine.

Example—A compound engine having cylinder areas in the ratio of 1:4, is running at 120 revolutions per minute. The stroke is 36", diameter of high pressure cylinder is 20", and the mean effective pressure on the low pressure cylinder is 15 lbs. per square inch. What is the horse-power of the engine? Ans.—834.86 horse-power.

DUTY OF AN ENGINE.

The duty of an engine is the number of footpounds of work done by the consumption of 100 lbs. coal. In 1891 a committee of the A. S. M. E. recommended a new unit, viz.: footpounds of work per million heat units furnished at the boiler. This is equal to the old unit when the coal imparts 10,000 H.U. to the water in the boiler or to the evaporation of 10.35 lbs. from and at 212° per pound of coal.

Taking the old unit, the duty of a pumping engine that will do 100,000,000 footpounds for every 100 lbs. coal burned is said to be 100 million.

Example I.—An engine requires 3 lbs. coal per 1 H.P. hour. What is the duty? Ans.—66 millions.

Example II.—The area of a pump plunger is 100 square inches, double stroke 4', number of double strokes 9600, coal burned 800 lbs. Gauge pressure on main pipe shows 50 lbs. and the height of this gauge is 23.1' above the water in the well. Find the duty. Ans.—28,800,000.

BRAKE HORSE-POWER.

It is often advisable to know the *actual power* given out by an engine independent of the power absorbed in friction, etc., in driving the engine itself. In order to do this it is necessary to either apply an absorption or a transmission dynamometer to the flywheel, or to a pulley keyed on the crank or first shaft. The power so obtained is termed the brake horse-power (B. H. P.) One of the simplest and most easily applied absorption dynamometers is that known as the Prony Brake.

The formula for finding the H. P. is as follows:

$$H. P. = \frac{2\pi rnP}{33000} = .0001904 \times r \times n \times P$$

when r = radius of pulley or horizontal distance from centre of shaft to centre of weight.

n = number of revolutions per minute

P = pull or weight in pounds.

It is important to observe that neither the diameter of the pulley nor the pressure of the friction blocks enter into the formula.

Example—Cylinder 7" diameter, stroke 10", pressure 55 lbs. $r = 2.5'$
 $n = 624$, $P = 96$. Ans.— $H.P. = 28.52$.

HORSE-POWER TRANSMITTED BY BELTS.

The ultimate strength of ordinary bark-tanned single leather belting varies from 3000 to 5000 lbs. per square inch of cross section. For convenience sake the tenacity is stated generally in lbs. per inch of width. For single belts the breaking stresses are from 750 to 1250 lbs. per inch of width. For double belts the breaking stresses are from 1500 to 2500. Allowing for joints this is reduced to about one-third of the strength of the solid leather and allowing a factor of safety of 5, we get a safe working stress of $\frac{1}{15}$ of the breaking stresses of the solid leather.

For single belts the working tension would be from 50 to 80 lbs.
 " double " " " " " " " " 100 " 160 "

In *practice*, however, 50 lbs. for single and 80 lbs. for double belts per inch of width are considered about the maximum. Under these conditions leather belts will run for many years.

HORSE-POWER THAT LEATHER BELTS WILL TRANSMIT PER INCH IN WIDTH AT VARIOUS SPEEDS.

By A. G. Brown, M.E.

Velocity of Belt in feet per minute.	Best Oak Tanned Belts.			Velocity of Belt in feet per minute.	Best Oak Tanned Belts. ..		
	Single.	Light Double.	Heavy Double.		Single.	Light Double.	Heavy Double.
100	.15	.21	.27	2100	3.18	4.45	5.73
200	.30	.42	.55	2200	3.33	4.67	6.00
300	.45	.64	.82	2300	3.49	4.88	6.27
400	.61	.85	1.09	2400	3.64	5.09	6.55
500	.76	1.06	1.36	2500	3.79	5.30	6.82
600	.91	1.27	1.64	2600	3.94	5.52	7.09
700	1.06	1.49	1.91	2700	4.09	5.73	7.36
800	1.21	1.70	2.18	2800	4.24	5.94	7.64
900	1.36	1.91	2.45	2900	4.39	6.15	7.91
1000	1.51	2.12	2.73	3000	4.50	6.36	8.18
1100	1.67	2.33	3.00	3100	4.60	6.58	8.45
1200	1.82	2.55	3.27	3200	4.69	6.79	8.70
1300	1.97	2.76	3.55	3300	4.77	7.00	8.86
1400	2.12	2.97	3.82	3400	4.84	7.21	8.96
1500	2.27	3.18	4.09	3500	4.90	7.31	9.06
1600	2.42	3.39	4.36	3600	4.95	7.40	9.16
1700	2.58	3.61	4.64	3700	4.99	7.48	9.24
1800	2.73	3.82	4.91	3800	5.03	7.54	9.29
1900	2.88	4.03	5.18	3900	5.05	7.60	9.34
2000	3.03	4.24	5.45	4000	5.08	7.64	9.37

Effect of Centrifugal Force on Belts.

When belts or ropes are run at high speeds the tensions in the two parts of the belts or ropes between the pulleys are greater than that calculated from the horse-power transmitted. This increase of tension is due to the centrifugal force set up in those parts of the belt which are in contact with the pulleys.

The centrifugal force has the effect of diminishing the normal pressure between the belt and the pulley and therefore of diminishing the resistance to slipping.

ENERGY OF A ROTATING FLYWHEEL.

The energy possessed by a moving body is called *kinetic energy*, and its amount for a falling body is obtained by finding the height through which it must fall to acquire the velocity of its motion. If this height be obtained, the work is equal to the height in feet \times weight in pounds, or, if w = weight in lbs. and h = height in feet, the work done = wh foot pounds.

In falling bodies, $h = \frac{v^2}{2g}$; g = the acceleration due to gravity $32'$ per second, and v = velocity in feet per second. \therefore if $h = \frac{v^2}{2g}$ then

$wh = \frac{wv^2}{2g}$, which is equivalent to saying, if a body of w lbs. moves with a velocity of v feet per second, the energy or accumulated work = $\frac{wv^2}{2g}$.

Example—The rim of a flywheel weighs 2 tons, and the mean velocity $30'$ per second. How many foot pounds of work are stored up in it? Ans.—56250 foot pounds.

RULE: Multiply the weight in pounds by the velocity in feet per second squared, and divide by 64.

Another example—Flywheel weighs 5 tons; mean radius of rotation $5'$; 100 revs. per minute. Owing to the load being suddenly diminished, the speed increases to 110 revs. per minute. What reserve power is stored up in the flywheel to overcome any sudden increase of the load? Ans.—89375 foot pounds.

CENTRIFUGAL STRESS IN FLYWHEELS.

There is no flywheel made that will not burst if it were only run fast enough. The centrifugal or centre flying force in the arms is directly proportional to the velocity squared, so that by doubling the velocity the centrifugal force or stress is quadrupled.

To Find the Centrifugal Force—

RULE I.: Multiply the weight in pounds by the velocity in feet per second squared, and divide by the radius multiplied by 32.

Formula, $\frac{Wv^2}{gr} = \text{centrifugal force.}$

RULE II.: Multiply the product of the weight and velocity squared by .03125, and divide by the radius.

$$\text{Formula, } \left(\frac{W \cdot v^2}{r} \right) .03125 = \text{centrifugal force.}$$

RULE III.: Multiply the product of the weight and radius by the revolutions per minute squared, and then by .000342.

$$\text{Formula, } = W \times r \cdot \text{revolutions per minute}^2 \times .000342 = \text{centrifugal force.}$$

Example—A flywheel 12' mean diameter weighs 6 tons and runs at 70 revolutions per minute. Find the centrifugal force. Ans.—121000.

BURSTING STRESS IN FLYWHEELS.

With centrifugal force the pressure is acting radially in all directions and is analogous to the pressure in a boiler. If we wish to determine the effective force tearing apart the rim of the wheel or the shell of a boiler we must find the resultant of this force acting in one direction and upon one-half of the rim. Take the last example under the heading of Centrifugal Stress, where the centrifugal force =

$\frac{Wv^2}{gr} = 121000$; this stress is supported at two points in opposite sides of the rim, and in order to break the wheel two pieces or both sections must burst, therefore the stress on each side = 60500 lbs.

$$\therefore \frac{Wv^2}{2} = \text{stress on each side trying to pull the two halves asunder.}$$

The weight of a cubic inch of cast iron weighs fully a quarter of a lb. or .26 lb. The number of cubic inches of iron in the rim will be = 46000, and the mean circumference of the rim is $144 \times \pi = 452''$.

$\therefore \frac{46000}{452} = 102$ square inches in the rim. If we now divide the stress on each side by the area multiply by π we get the bursting stress per square inch;

$$\therefore \frac{60500}{102 \times \pi} = 188 \text{ lbs. per sq. inch.}$$

From this, we get the following formula:

$$\frac{wv^2}{2 \text{ Area } \pi} = \text{Bursting stress per sq. inch.}$$

This formula can be simplified as follows:

Let D = diameter of wheel in feet.

r = radius in feet.

n = No. of revs. per minute.

v = velocity in feet per minute.

$$\begin{aligned} \text{Stress per sq. inch} &= (r \times n)^2 \times .001065 \\ \text{" " (approx.)} &= (r \times n)^2 \times .001 \\ \text{" " } &= (D \times n)^2 \times .0002664 \\ \text{" " } &= v^2 \times .00027 \end{aligned}$$

Example—A flywheel 12' diameter, weighing 12000 lbs., runs at

70 revs. per minute. Find the bursting stress per square inch. Suppose wheel had six arms, find the maximum number of revolutions the wheel could be run at without breaking, neglecting in the calculation the binding strength of the rim. Each arm has a breaking stress of 120,000 lbs. Ans.—168 revs.

BURSTING STRESS OF FLYWHEEL.

In practice 100' per second is about the maximum which corresponds to a stress of about 970 lbs. per square inch. Good cast iron has a tensile strength of about 20000 ; therefore at this velocity, 100' per second, there is a large factor of safety, but, as the centrifugal forces increase as v^2 , we find that cast iron will burst at 454' per second, as follows :

$$\begin{aligned} \text{Stress per square inch} &= (\text{velocity in feet per minute})^2 \times .00027 \\ \text{“ “ “ “} &= (\text{velocity in feet per second})^2 \times .0972 \\ \therefore 20000 &= (v' \text{ per second})^2 \times .0972 \\ v' &= \frac{\sqrt{20000}}{.0972} = 454 \text{ feet per second.} \end{aligned}$$

ZEUNER'S DIAGRAM.

Given the position of crank at point of cut-off, the amount of lead, travel of valve, to determine the angular advance and amount of outside lap.

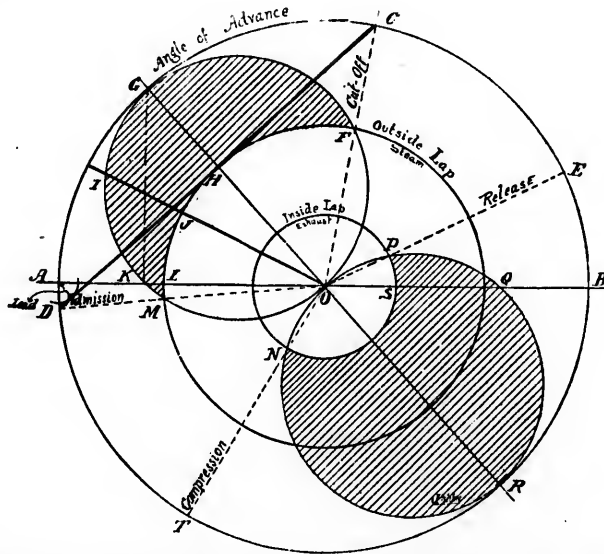

Draw two lines at right angles cutting each other at O . With centre O and radius = half the travel of the valve describe the circle $AGCEBR$. Draw OC = position of crank at cut-off. With A as centre and radius = lead of the valve, describe part of a circle and then draw CD touching this circle. Through O draw OG at right angles to CD . Bisect CDG at the point G then draw GOR . On

OG describe circle $GMOF$ and on OR describe the circle $OPQRN$. From centre O radius OH describe the circle $HFML$. This diagram is now completed and we can readily see the distance the valve has moved from its central position for any position of the crank, and also the opening of the port to steam at that point. Suppose crank to be at GOA and having moved in the direction as shown by the arrow, the distance OG is the amount the valve has moved from its central position and GH represents the opening of port to steam at that particular point. The shaded portion $GFHM$ of the diagram shows the opening of the port to steam. By the diagram we see that when crank is in position OD the valve is just beginning to opening and when it reaches the dead centre AB the port is open an amount $=KL =$ lead of valve. When crank reaches OE , release, the valve has passed its middle position and is distant from it on the other side an amount $OP =$ inside lap; therefore at that point the exhaust opens and continues to open. When the crank has reached B the valve has moved from its centre a distance $=OQ$, and since $OS =$ the inside lap the port is open to exhaust an amount $=QS$. When crank arrives at R the port is full open to exhaust and when it arrives at OT the valve is closed and compression begins.

Given the travel, the lap, and the angle of advance, to find the point of cut-off, the amount of lead, etc.

Draw the circle $AGCEBR$ to represent the travel of the valve, and the circle $HFML$ to represent the outside lap and draw the angle $GOC =$ angle of advance. Bisect OG and describe the valve circle $GMOF$ as before; we now see that when the crank is in the position OA the valve is open an amount equal to KL , therefore KL is the lead of the valve. Through the point F where the lap circle intersects the valve circle draw OC , then OC represents the position of the crank at cut-off.

Given the travel, the lap and the lead, to find the angle of advance. As usual draw the circle to represent the valve travel. Lay off $OL =$ the lap and $KL =$ lead of the valve. From K erect KG perpendicular to AB ; then the angle GOC is the angle of advance.

Examples—Travel of valve $8\frac{3}{4}$ " , outside lap $2\frac{1}{4}$ " , inside lap $\frac{1}{4}$ " , angle of advance 35° . Find the points of admission, cut-off release, compression and the amount of lead.

Travel of valve 5 " , outside or steam lap $\frac{3}{4}$ " , angle of advance $22\frac{1}{2}^\circ$. Find graphically the position of the crank at admission and cut-off.

VALVE SETTING (Slide Valve).

In setting the valves of an engine, it is of primary importance that the points of opening of the valves be known and trammed at convenient points on valve rod. To do this, the necessary tools are a piece of very thin tin, a piece of $\frac{1}{4}$ " steel rod 7 " long, sharp-pointed and hardened at each end, one end being bent square $1\frac{1}{2}$ ".

To Tram the Valve.—Remove the steam chest cover and place the tin in the head port, bringing the valve against it; then from a fixed centre point on end of steam chest (not the gland) tram a line on valve rod, marking same with a fine centre punch, repeating the

operation on the other steam port. After satisfying yourself that steam chest and ports are clear, put on cover and connect eccentric rod. Proceed to set valve by placing engine on one dead centre; then from fixed point on steam chest use tram to mark valve rod, turn engine to other dead centre and again mark rod; then compare marks, and adjust by lengthening or shortening rod or turning eccentric, as required.

TO PLACE AN ENGINE ON THE DEAD CENTRE.

To place an engine on its dead centre, bring the crosshead to within about half an inch of the end of its travel. Take a pair of dividers and from a point on the guides strike an arc of a circle on the crosshead, and, with the engine in the same position, tram from a point on the floor to the rim of the wheel; then move the engine in the direction it is to run until the crosshead has passed the end of its travel and returned to a point where the dividers will coincide with the mark already made on the crosshead. Make another tram mark on the rim of the flywheel, and midway between these two marks make a centre punch mark for a dead centre mark, bring the flywheel to a point that the point of the tram will just enter the dead centre mark, and the engine is on its exact centre at that end; repeat the operation on the other end

In all cases, move the engine in the direction it is to run, and, if moved past the dead centre mark, it must be backed up far enough to take up the lost motion before reaching the mark again.

VALVE SETTING.

Corliss Engine.--Remove the back covers from valve cylinders; the lines marked on valve and cylinder ends are lines of opening.

On the back hub of wrist plate will be found a centre line, a line will also be found on the hub of stand which supports wrist plate—when these two lines meet, the wrist plate will then be in its central position. On either side of centre line of wrist plate stand will be found another line, and when centre line of wrist plate coincides with either of these lines, it will be in its extreme position. Place the wrist plate in its central position and by the means of adjusting nuts make the lengths of the valve connections such that each steam valve may have the necessary lap $\frac{1}{8}$ to $\frac{3}{8}$ —depending on size of engine, and that the exhaust valves may be just opening or without lap. Then adjust length of eccentric rod, that wrist plate may vibrate equally. Place the crank on any dead centre and turn the eccentric on the shaft in the direction engine is to run enough to show an opening or lead of say $\frac{1}{32}$ to $\frac{1}{16}$ of an inch, then tighten the set screw in eccentric and place crank on the other centre and note if lead is the same, if not, adjust as required.

To adjust the disengaging gear, let the governor remain in its lowest position, move wrist plate to extreme of travel and hold in this position, adjusting cam rods as required.

To prove the correctness of the cut-off adjustment, raise the governor to its working plane, blocking it there; then with eccentric connected to wrist plate turn, engine slowly in its running direction,

and measure on the slide the distance the crosshead has moved from its extreme position at either end, if cut-off is equalized the distance should be the same.

In all cases it is desirable that an indicator be used to more accurately adjust the setting of the valves so that the engine may be in the best possible condition for economical work.

Brown Engine.—This is a four-valve engine, the valves being of the gridiron type. The most important point is to know the laps and openings of the several valves. The steam valves are generally marked on the stirrup block, flush with the top of its guide, the exhaust openings and laps being marked on the end of exhaust rod.

There being so many points in this valve gear that can be changed, the marks should in all cases be verified. This is usually done by getting the point of opening through the peep holes in back of steam and exhaust chests, and adjust to original marks by lengthening or shortening valve rods, as required. Having marked or verified the position of all valves, proceed to set by placing the engine on the head end centre, see that gears are secured in position to turn engine in desired direction. Engage clutch, then turn head eccentric in the direction side shaft is to run until the lower mark on stirrup block is above the guide, say $\frac{1}{8}$ of an inch; secure the eccentric. Turn the engine back one-fifth of its stroke, and turn exhaust cam ahead until the outside mark on exhaust rod coincides with the tram or gauge, with the inner mark approaching same. Secure the cam, place the engine on crank end centre, and repeat the operation. Then block the governor in highest position, turn hand wheel and see if the steam valves trip when the lowest mark on stirrup block shows, say, $\frac{1}{8}$ of an inch above guide, setting cut-off shaft or levers until it does. Then place governor in lowest position, turning hand wheel to see if valves will unhook. Finally, set governor in working plane, turning engine to see if cut-off is equalized.

THE SAFETY VALVE.

RULES FOR AREA OF SAFETY VALVES.

Philadelphia Ordinances.—Every boiler when fired separately, and every set or series of boilers when placed over one fire, shall have attached thereto, without the interposition of any other valve, two or more safety valves, the aggregate area of which shall have such relations to the area of the grate and the pressure within the boiler as is expressed in the following schedule :

Schedule.—Least aggregate area of safety valve (being the least sectional area for the discharge of steam) to be placed upon all stationary boilers with natural or chimney draft : Area of combined safety valves =
$$\frac{22.5 \text{ grate surface in sq. feet}}{\text{Press. in lbs. per sq. in. above atmsp.} + 8.62}$$

RULE OF U. S. SUPERVISION INSPECTORS OF STEAM VESSELS:

Lever safety valves to be attached to marine boilers shall have an area of not less than 1 sq. in. to 2 sq. ft. of grate surface in the boiler, and the seats of all such safety valves shall have an angle of inclination of 45° to the centre line of their axes.

Spring loaded safety valves shall be required to have an area of not less than 1 sq. inch to 3 sq. feet of grate surface of the boiler, except as hereinafter otherwise provided for water tube or coil, and sectional boilers; and each spring loaded valve shall be supplied with a lever that will raise the valve from its seat a distance of not less than that equal to one-eighth the diameter of the valve-opening, and the seats of all such safety valves shall have an angle of inclination to the centre line of their axes of 45°. All spring loaded safety valves for water tube or coil and sectional boilers required to carry pressures exceeding 175 lbs. per square inch shall be required to have an area of not less than one square inch to six square feet of grate surface of the boiler. Nothing herein shall be construed so as to prohibit the use of two safety valves on one water tube or coil and sectional boiler, provided the combined area of such valves is equal to that required by rule for such valve.

The Canadian Steamboat Act provides that every safety valve must have a lift equal to one-fourth its diameter at least. The openings to and from the valve must each have an area not less than the area of the valve, and the area of the safety valve must be equal to one-half inch for every square foot of grate surface of the boiler.

The following are rules for the calculation of the weight, length of lever, etc., for safety valves :

Let W = weight of ball at end of lever in lbs.
 w = " " lever in lbs.
 w_1 = " " valve and spindle in lbs.
 L = distance from fulcrum to centre of W in inches
 l = " " " " " " " valve
 G = " " " " " " " gravity of lever in inches
 A = area of valve in square inches
 P = pressure in lbs. per square inch.

By the principle of moments we get

$$P \cdot A \times l = W \times L + w \times G + w_1 \times l \quad (1)$$

$$\therefore P = \frac{WL + wG + w_1 l}{Al}$$

By transposing the equation we get

$$W = \frac{P \cdot A l - w G - w_1 l}{l} \quad (2)$$

$$\text{Or } L = \frac{P A l - w G - w_1 l}{W} \quad (3)$$

Examples—Find the weight to be placed at the end of a lever 20" long weighing 15 lbs., the area of the valve being 8 square inches. Weight of valve and spindle 6" acting at a distance of 2" from fulcrum. Steam pressure 60 lbs. Ans.—39.9 lbs.

If the weight of the lever and the weight of the valve and spindle are omitted from the calculation, the formula becomes

$$P = \frac{WL}{Al}$$

$$\text{Or } W = \frac{P \cdot Al}{L}$$

$$\text{And } L = \frac{PA l}{W}$$

OF INTEREST TO ENGINEERS.

By organized and persistent effort engineers can advance their interests.

How many there are who would derive incalculable benefits could they be induced to practise what is implied by the above heading, but who, by ignoring this, miss many great opportunities, and wander or drag along in the same old rut. One may well be surprised to find what progress can be made by the end of a year by steadfast application for the space of one-half hour each day. How much time is lost by aimlessly dreaming and living without any solid beneficial subject for thought! A great author has said, "Knowledge is power;" therefore, if we lack knowledge, we cannot properly embrace opportunities presenting themselves, then, by all means, let us use organized and persistent effort to secure knowledge. We cannot all expect to go to college; and, bearing this in mind, we must remember that the most college can do for us is to put us on the road leading to knowledge; so, those of us who have been unable to get a college education should do the best we can to advance ourselves by organized and persistent effort. Remember, we cannot know it all, as it takes everybody to know everything, and very little of anything is yet known. Steer clear of him who claims to know it all, for, if you do not, association with such a man will have a tendency to disgust you with your fellowmen, and more in particular by the way in which he will expose his own ignorance.

A few things that an engineer should do.—Give his work his undivided attention. Give his employer the benefit of his experience. Give his attention to the best publication, so that he will advance by the experience of others. Give his influence and experience for the benefit of his brother engineers, and do all in his power to advance the standing of an engineer by being sober, industrious, and never forgetting that it is his first duty to look after the best interests of his employer.

What engineers should at all times desire.—Clean engine-room, clean feedwater, clean coal, clean fire, clean oil. Steady employment, steady steam pressure, steady feed and steady and regular lubrication. Silent action of his engine, steam distribution perfect, short watches. High economy, high steam pressure, high expansion of steam, and last, but not least, high wages.

THE
Royal Electric Co.,

MONTREAL.

TORONTO.

MAKERS OF

Electrical Machinery

for

Incandescent Lighting,**Arc Lighting,****Electric Railways,****Power Transmission,****Mining and Mill Work.**

Canadian Manufacturers of the

"S.K.C." MULTIPHASE SYSTEM**of Generators, Motors, Transformers.**

Write us for Plans, Specifications and Estimates on
proposed Electric Plants.



ELECTRICAL
DEPARTMENT



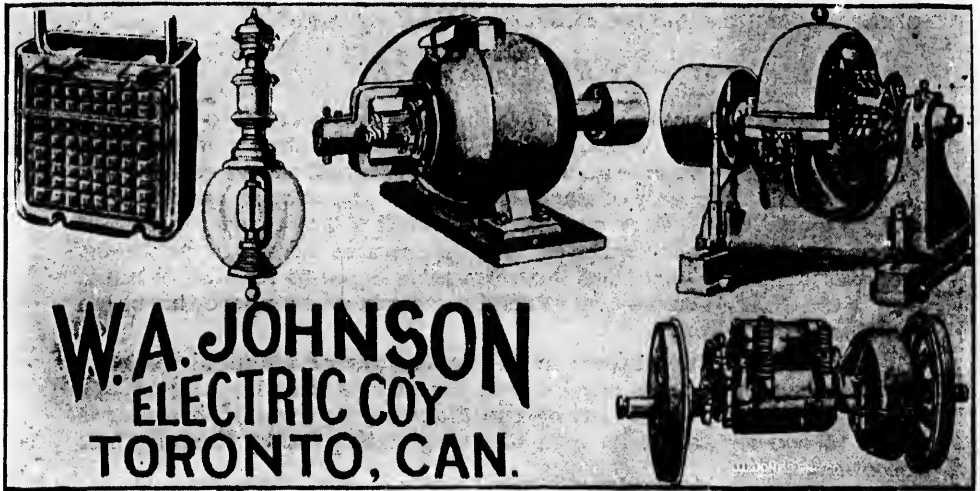

W.A. JOHNSON
ELECTRIC COY
TORONTO, CAN.

The advertisement features a collection of technical illustrations. On the left is a rectangular control panel with a grid of buttons. Next to it is a hanging oil lamp with a glass globe and a decorative top. In the center is a large, cylindrical electric motor mounted on a base. To the right is a complex mechanical assembly, possibly a pump or a large motor, with various gears and shafts. Below this is another smaller motor or pump assembly with two large flywheels.

H. W. PETRIE,

MACHINIST AND
GENERAL MACHINE
DEALER.

Send for
Descriptive
Catalogue.



New and Second Hand Engines
and Boilers of all types bought,
sold and exchanged.

ENGINEERS AND OTHERS ALWAYS WELCOME
AT WORKS

NEXT UNION STATION,

TORONTO, ONT.

ELECTRICITY.

Ohms Law.—The strength of a current varies directly as the Electro-motive-force and inversely as the resistance or the intensity of the current is equal the *E.M.F.* divided by the *R*.

$$C = \frac{E}{R}; R = \frac{E}{C}; E = CR.$$

The unit of resistance is called the Ohm and is equal to 10^9 C.G.S. (centimeter, gram, seconds,) units. It is the resistance of a column of pure mercury 1 square millimetres in section and 106.21 centimetres long at 32°F . The unit of current is called the ampere, and is 10^{-1} C.G.S. units. It is that current which will deposit 4.025 grams of silver per hour or decompose .0055944 grams of water per hour. The unit of *E.M.F.* is called the volt and is equal to 10^8 C.G.S. units, and is the *E.M.F.* necessary to send a current of 1 ampere through a resistance of 1 Ohm.

Resistance.—The resistance of conductors of identical material varies inversely as their section and directly as their length; or, the length of one wire multiplied by the diameter squared of the other is equal to the square of its own diameter multiplied by the length of the other.

$$\text{Formula} \quad l_1 d_2^2 = l_2 d_1^2$$

$$\text{or} \quad \frac{R_1}{R_2} = \frac{l_1 d_2^2}{l_2 d_1^2} \quad (1)$$

when $R_1 d_1 l_1$ = resistance, diameter and length of one wire

$R_2 d_2 l_2$ = resistance, diameter and length of other wire.

From the above we get

$$d_2^2 = \frac{R_1 l_2 d_1^2}{l_1 d_2^2}$$

$$\text{or} \quad d_2 = \frac{\sqrt{R_1 l_2 d_1^2}}{l_1 d_2^2}$$

Example—Find the diameter of a copper wire 480' long that has twice the resistance of another copper wire 120' long and measuring .25 of an inch in diameter. Ans. —.35".

The total resistance of a wire varies *directly* with the *specific* resistance of the substance of which the wire is made.

Let S_1 and S_2 = specific resistance of wires (1) and (2)

or K_1 and K_2 = conductances of the " (1) and (2)

Then from (1) we get

$$\frac{R_1}{R_2} = \frac{l_1 d_2^2 \times S_1}{l_2 d_1^2 \times S_2} = \frac{l_1 d_2^2 K_2}{l_2 d_1^2 K_1}$$

$$\text{Or} \quad R_2 = \frac{R_1 l_2 d_1^2 S_2}{l_1 d_2^2 S_1} = \frac{R_1 l_2 d_1^2 K_1}{l_1 d_2^2 K_2}$$

ESTABLISHED 1850.

THE E. HARRIS COMPANY,

OF TORONTO, LIMITED,

44 KING STREET EAST,

ENGINEERS' AND DRAUGHTSMEN'S SUPPLIES.

Drawing Boards, T and Set Squares,
Scale Rules, Drawing Instruments,
Blue Print and other Drawing Papers,
Higgins Ink, Tracing Cloth, etc., etc.

TORONTO ELECTRIC MOTOR COMPANY, Contractors for Complete

◆ **ELECTRIC LIGHT and
POWER EQUIPMENTS**

IN ALTERNATING AND
DIRECT CURRENTS.

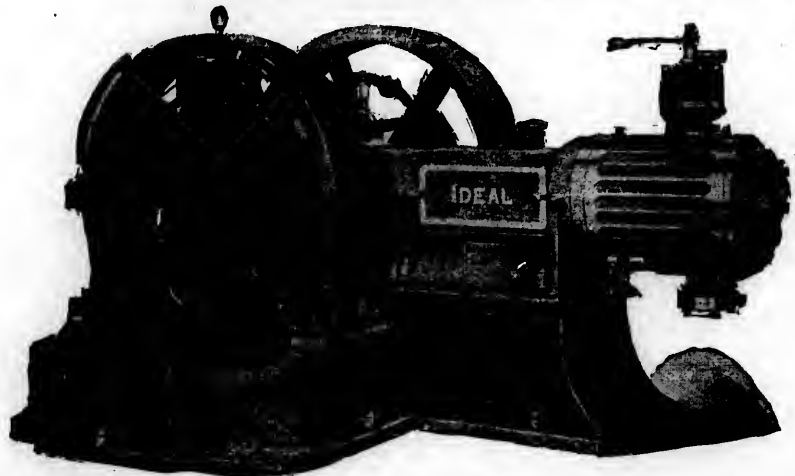

Armature Rewinding and General
Repairing at Reasonable Prices
TELEPHONE 1854.

103, 105, 107, 109 Adelaide St. W.
TORONTO.

Example—The resistance of a mile of pure copper wire .134" diam. is 3.03 Ohms. Calculate the resistance of half a mile of German silver wire .0335" diameter. The specific resistance of copper is 1642 and that of German silver 21170. Ans.—312.52 Ohms.

SPECIFIC RESISTANCE IN CGS UNITS AT 0° C.

Silver annealed,	1521	CGS units.	Iron annealed	9827	CGS units.
" hard drawn	1652	" "	Nickel	12600	" "
Copper annealed	1615	" "	Tin	13360	" "
" hard drawn	1642	" "	Lead	19847	" "
Gold " "	2154	" "	German Silver	21170	" "
Zinc	5690	" "	Platinoid	34000	" "
Platinum anneal'd	9158	" "	Mercury	96146	" "

The resistance of a wire .001" diameter and 1' long at 60°F. is 10.4 Ohms, and from this data can be readily calculated the resistances of all other wires.

Example I.—What is the resistance of 1000' of wire .1" diameter, knowing that 1 mil. foot (.001" diam. × 1' long) has 10.4 Ohms resistance?

By transposing formula (1) we get

$$R_1 l_2 d_1^2 = R_2 l_1 d_2^2 \quad \text{or}$$

$$R_1 = \frac{R_2 l_1 d_2^2}{l_2 d_1^2} = \frac{10.4 \times 1000 \times 1^2}{1 \times 100^2} = 1.04 \text{ Ohms.}$$

Example II.—What length of wire .05" diameter would be required so that there would be a resistance of 9 Ohms? Ans.—2163.

RESISTANCE OF DERIVED CIRCUITS.

The joint resistance of several circuits in *multiple* is

$$\frac{I}{\frac{1}{r_1} + \frac{1}{r_2} + \frac{1}{r_3} + \dots} \quad \text{where } r_1 r_2 r_3 + \dots = \text{the resistance of each branch.}$$

If there are only two wires in multiple the joint resistance is

$$\frac{I}{\frac{1}{r_1} + \frac{1}{r_2}} = \frac{r_1 r_2}{r_1 + r_2} = \frac{\text{product of the resistances}}{\text{sum of the resistances}}$$

Example—Three wires in derived circuit have a joint resistance of 6 Ohms. What resistance must be inserted in multiple so that the joint resistance will be reduced to 3 Ohms.

$$\frac{I}{\frac{1}{6} + \frac{1}{x}} = 3 \text{ Ohms} \quad \therefore x = 6 \text{ Ohms.}$$

Example I.—What must be the R of the shunt used with a galvanometre whose R is 4500, so that the R of the shunted galvanometre shall be 450 Ohms. Ans.—500 Ohms.

Leitch & Turnbull,

Electric, Hydraulic,
Steam and
Hand Power :::: Elevators

Of the latest designs for safety, durability, speed and artistic effect.

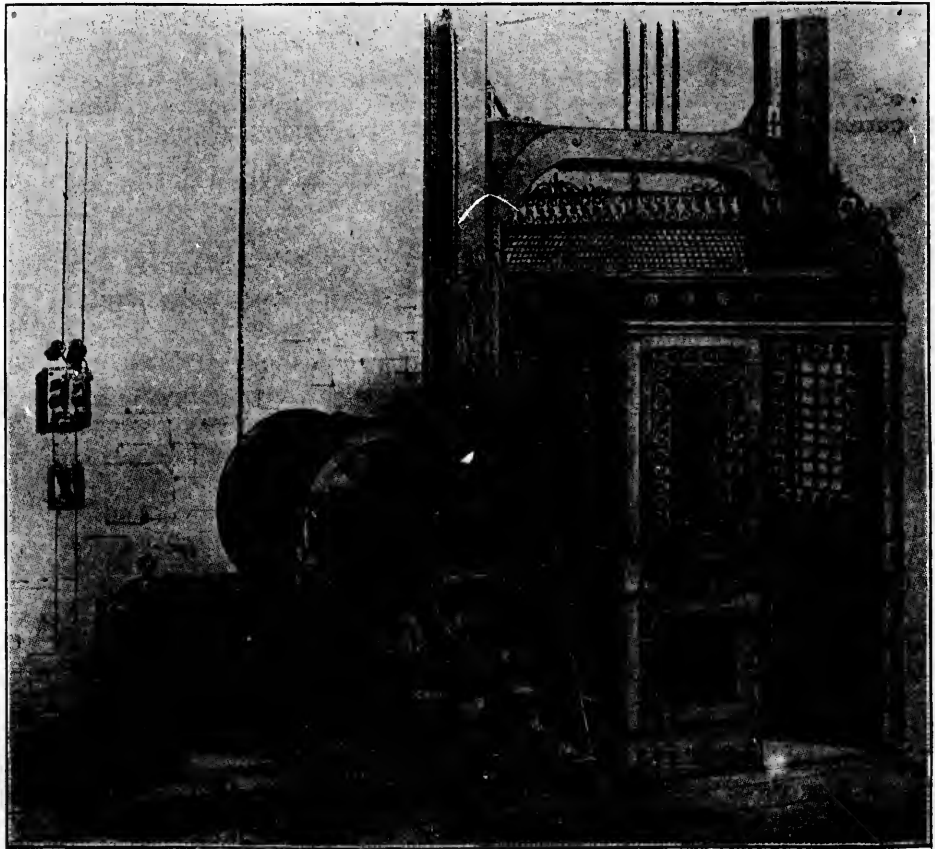

ADDRESS
CANADA ELEVATOR WORKS,
HAMILTON.

OR
ADELAIDE STREET WEST,
TORONTO.

DIVISION OF CURRENT.

The relative strength of current in the different branches of a divided circuit is directly proportional to their conductivities, or in the inverse proportion to the resistances.

Example I.—Three wires, 5, 8 and 12 Ohms, are joined in multiple, and a current of 49 amperes is sent through the circuit. How much will flow through each wire?

The joint conductivity of several wires, r_1, r_2, r_3 , in multiple, is = $\frac{1}{r_1} + \frac{1}{r_2} + \frac{1}{r_3} +$

$\therefore \frac{1}{5} + \frac{1}{8} + \frac{1}{12} = \frac{49}{120}$. From this, we see that the current divides, as it were, into 49 parts,

24	of which	flow	through	the	wire	of	5	Ohms	resistance.
15	"	"	"	"	"	"	8	"	"
10	"	"	"	"	"	"	12	"	"

Example II.—A current of 39 amperes is sent through a circuit of 3 wires in multiple having 8, 12 and 16 Ohms respectively. What current will flow through the 16 Ohm wire? **Ans.**—9 amperes.

ELECTRICAL UNITS OF MEASUREMENT.

The centimetre = unit of length = .3937".

The gram = unit of mass = 15.432 grains.

The second = unit of time = $\frac{1}{86400}$ part of a mean solar day.

The sq. cent. = unit of area = .15501 sq. inch.

The cub. cent. = unit of volume = .061027 cubic inch.

The unit of velocity is the velocity of a body which moves through unit distance in unit time, or the velocity of 1 centimetre per second.

Momentum is the quantity of motion in a body, and is measured by mass \times velocity.

Acceleration is the rate of change of velocity. The unit of acceleration is that acceleration which imparts unit changes of velocity to a body in unit time, or an acceleration of 1 centimetre per second—per second.

The acceleration due to gravity is considerably greater than this = 32.2 feet per second, or 981 centimetres $\therefore g = 981$ centimetres.

Force is that which produces motion or change of motion in a body. The unit of force is that force which, when acting for one second on a mass of 1 gram, gives to it a velocity of 1 centimetre per second. It is called the *dyne*.

The force with which the earth attracts any mass is usually called the weight of that mass, and the force with which a body gravitates, *i.e.*, its *weight* (in dynes) is found by multiplying its mass (in grams) by the value of *g*.

Work is the product of a force and the distance through which it acts. The unit of work is the work done in overcoming unit force through unit distance, *i.e.*, in pushing a body through a distance of 1 centimetre against a force of 1 dyne. It is called the *Erg*.

Volcanic Patent

PERFECT
IN OPERATION.
THOUSANDS IN
USE.

WILL OUTWEAR ANY
GRATE
IN THE MARKET.

Shaking Grate.

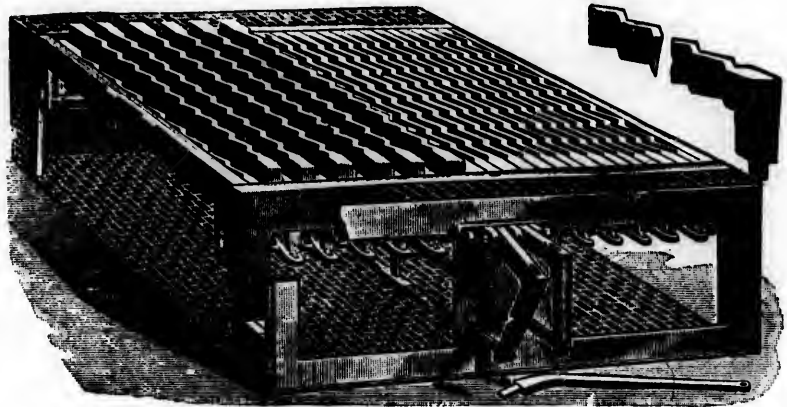

If You
Wish

To reduce your Coal Bills,
To increase your Steam Power,
To burn Hard or Soft Coal Screenings,
To have a better Draft,

Use the Volcanic Grate.

MANUFACTURED BY

The **Gurney Foundry Company,**

Toronto, Ont.

LIMITED.

Send for Illustrated Catalogue.

Correspondence Solicited.

The force with which gravity pulls a mass of 1 gram is 981 dynes; therefore, to lift a mass of 1 gram through a distance of 1 centimetre is = 981 ergs of work or g ergs.

Power is the rate of working. The unit of power is called the *Watt*, and is equal to 10^7 ergs per second.

THE HORSE-POWER.

1 foot = 30.479 centimetres.

1 lb. = 453.59 grams.

$$\therefore 1 \text{ ft. lb.} = g (30.479 \times 453.59) = 13562600 \text{ ergs} = 1.35626 \times 10^7 \text{ ergs}$$

One horse-power = 33000 ft. pds. per minute = 550 ft. pds. per second
= $550 \times 1.35626 \times 10^7$ ergs.

But 1 Watt = 10^7 ergs.

$$\therefore 1 \text{ H.P.} = 550 \times 1.35626 = 745.941 \text{ Watts} \\ = 746 \text{ Watts very nearly.}$$

$$\text{H.P.} \times 746 = EC = C^2 R = \frac{E^2}{R}$$

$$\text{H.P.} = \frac{EC}{746} = \frac{C^2 R}{746} = \frac{E^2}{746 R}$$

The unit of Quantity is called the Coulomb = 10^{-1} CGS units. It is the quantity given by an ampere in a second.

1 volt Coulomb or 1 Watt during every second } = 10,000,000 ergs.
1 volt ampere during every second, or Joule } = .737324 foot pds.

The Joule (Joule's mechanical equivalent) is therefore equal to the work done or heat generated by a Watt in a second and is
= .737324 ft. pds.

$$\therefore E \cdot C \cdot t = C^2 R t = \frac{E^2 t}{R} = E Q = \text{Joules}$$

when Q = quantity in Coulomb.

$$\therefore \text{Work in foot pds.} = .737324 E Q$$

Example—How much electricity will 330,000 foot pds. send through a circuit with an *E.M.F.* of 60 volts?

$$\text{Work} = .737324 E Q$$

$$Q = \frac{330000}{.737324 \times 60} = 7460 \text{ Coulombs.}$$

Now Coulombs per second = Amperes

$$\therefore 7460 \times 60 = \text{Watts per second}$$

$$\therefore \frac{7460 \times 60}{746} = \text{H.P.} = \frac{330,000}{550} = 600 \text{ horse-power.}$$

Summary of Formulæ—

$$\text{H.P.} = \frac{C^2 R}{746} \\ = \frac{E \cdot C}{746} \\ = \frac{E^2}{746 R}$$

Kay Electrical Manufacturing Co.

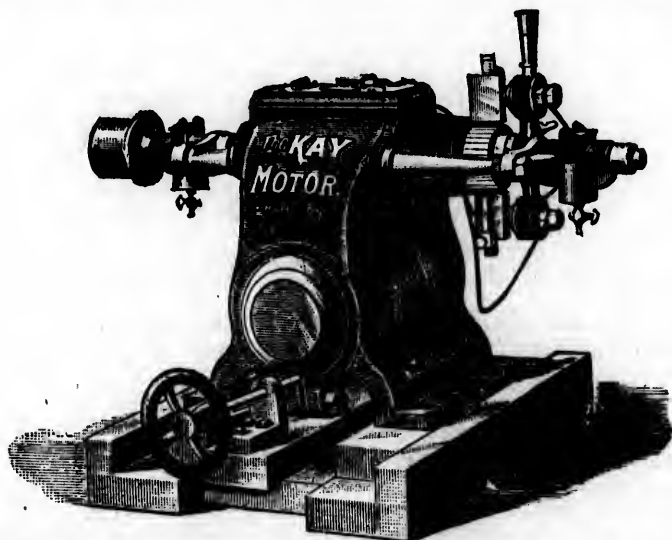

255 JAMES STREET NORTH, HAMILTON, TELEPHONE NO. 958.
58 ADELAIDE STREET WEST, TORONTO, TELEPHONE NO. 1214.



ENGINEERS and FIREMEN!

TRY ME AND YOU CAN RECOMMEND ME.

Work in foot pounds = .737324 $E Q$

$$C = \frac{E}{R} = \frac{\sqrt{746 \text{ H.P.}}}{R}$$

$$= \frac{746 \text{ H.P.}}{E}$$

$$E = C.R = \frac{746 \text{ H.P.}}{C} = \sqrt{746 \text{ H.P.} \cdot R} = \frac{\text{Work in ft. pds.}}{.737324 Q}$$

$$R = \frac{E}{C} = \frac{746 \text{ H.P.}}{C^2} = \frac{E^2}{746 \text{ H.P.}}$$

THE HEATING EFFECT OF THE CURRENT.

The unit of heat called the therm or French caloric is that quantity of heat necessary to raise 1 gram of water 1° centigrade.

The British unit = 1 lb. deg. F. = 772 ft. pds.
= 1.403 H.P.

But 1 H.P. = 746 Watts.

∴ 746 × 1.403 = 1047.03 Watts for 1 B.H.U.

but 1 Watt = 10⁷ ergs.

∴ 1 lb. deg. F. = 1047.3 × 10⁷ = 1.0473 × 10¹⁰ ergs.

From this follows that 1 lb. deg. cent. = 1884.66 × 10⁷ ergs.

and as there are 453.59 grams per lb.

$$\therefore \frac{1884.66 \times 10^7}{453.59} = 4.15495 \times 10^7 \text{ ergs.}$$

or 1 gram. deg. centigrade = 4.15495 × 10⁷ ergs.

Let J = Joules mechanical equivalent.

= amount of mechanical work 1 caloric is capable of doing.

H = number of heat units.

JH = work done = $C^2 R.t.$

when t = time in seconds.

If Q = the quantity of electricity passed

E = $E.M.F.$ or difference of electrical level, then, as in lifting a weight, the work done against gravity is mass × height through which it has been raised, so

QE = total work = W

$JH = QE = W.$

But since C = the quantity that passes each second and t the number of seconds, then

Ct = total quantity passed = Q

$$\therefore JH = QE = CtE.$$

By Ohm's law $C = \frac{E}{R}$

and substituting CR for E we get

$$JH = C^2 Rt$$

$$H = \frac{C^2 Rt}{J}$$

ESTABLISHED 1879.

TELEPHONE 637.

R. G. McLEAN,
JOB AND BOOK **P** RINTER,

ONLY FIRST-CLASS WORK.
ORDERS PROMPTLY AND PROPERLY
EXECUTED AT FAIR PRICES.

32 AND 34 LOMBARD STREET,
TORONTO.

THIS BOOK IS A FAIR SAMPLE OF OUR EVERYDAY WORK.

The value of J is given as follows :

$$\begin{aligned} J &= 4.15495 \times 10^7 \text{ ergs. for 1 gram deg. cent.} \\ &= 1884.66 \times 10^7 \text{ ergs. for 1 lb. deg. cent.} \\ &= 1047.03 \times 10^7 \text{ ergs. for 1 lb. deg. F.} \end{aligned}$$

Example—A current of 20 amperes flowing through 10 Ohms, R , heats 20 lbs. water from 60 to 65° F. Find length of time, C , was flowing.

$$\begin{aligned} H &= \frac{C^2 R t}{J} \\ H &= 20 \text{ lbs. } (65-60) = 100 \text{ units (lbs. deg. F.)} \\ J &= 1047.03 \times 10^7 \end{aligned}$$

The formula so far is in absolute units, and to reduce same to practical units we have

$$\begin{aligned} H &= \frac{(C \times 10^{-1})^2 \times R \times 10^9 \times t}{1047.03 \times 10^7} = \frac{C^2 R t}{1047.03} \\ \therefore H &= \frac{20^2 \times 10 \times t}{1047} \\ t &= 26.175 \text{ seconds.} \end{aligned}$$

In this example no allowance has been made for radiation.

Example—A current was sent through a wire of 12 Ohms resistance, wholly immersed in 25.5 grams of water, contained in a glass vessel. At the end of 4 mins. the rise in temperature was observed to be 3° C. Calculate the strength of the current. Ans.—1.05 amperes.

COMPARISON OF HEAT.

Suppose it is required to compare the amount of heat produced in wires of different resistances by currents of different strength for different times.

$$\begin{aligned} \text{Let the heat in one wire} &= H_1 = C^2 R t \times .24 \\ \text{“ “ 2nd “} &= H_2 = C_2^2 R_2 t_2 \times .24 \\ \frac{H_1}{H_2} &= \frac{C^2 R t \times .24}{C_2^2 R_2 t_2 \times .24} = \frac{C^2 R t}{C_2^2 R_2 t_2} \end{aligned}$$

That is to say, the heat produced in one wire, multiplied by product of current squared, resistance and time in seconds of second wire, is equal to the heat produced in the second wire multiplied by the current squared multiplied by the product of the current squared, resistance and time in seconds of the first wire.

Example—The resistance of one wire is 5 Ohms, and that of another is 4 Ohms. Find the ratio of the heat produced in the one wire to that produced in the other wire—(1) when joined in series ; (2) when joined in multiple when a current is sent through them. Ans.—
(1) $H_1 : H_2 :: 5 : 4$; (2) $H_1 : H_2 :: 4 : 5$.

HEATING BY ELECTRICITY.

It is found that the heat produced in a conductor is directly proportional—(1) to the square of the current; (2) to the resistance of the conductor; and (3) to the time the current is flowing or expressed by the equation.

$$JH = C^2 Rt,$$

when J = Joule's mechanical equivalent.
 H = Number of heat units.

As 1 H.P. = 550 ft. lbs. = 746 Watts and one British heat unit is equal to 772 ft. lbs., therefore 1 lb. deg. F. is equal to $\frac{772}{550} = 1.403$ H.P. or 1047.3 Watts. This will represent the value of J when dealing with British heat units:

$$H = \frac{C^2 Rt}{1047} = \frac{C \cdot Et}{1047} = \frac{E^2 t}{1047R}$$

In the best of lighting and power plants it takes a coal consumption of $2\frac{1}{2}$ lbs. per indicated horse-power per hour; and allowing 90% efficiency in the engine, 93% in generator and 90% in the circuits, we get, say, 75% combined efficiency, or for every horse-power generated at the engine we get $\frac{3}{4}$ H.P. at the heater on the consumer's premises, which is equivalent to 3.3 lbs. coal per E.H.P.

For a coal consumption of $2\frac{1}{2}$ lbs. we get

$$H = \frac{C^2 Rt}{J} = 1926$$

or 770 heat units per lb. coal.

In good hot water or steam heating systems an average of 9500 heat units are utilized per lb. coal. Therefore, the relative efficiencies are as 770 : 9500 or 1 : 12.5; that is to say, to heat by electricity would cost $12\frac{1}{2}$ times more than by steam. As there are very few plants, generating one 1 H.P. for $2\frac{1}{2}$ lbs. coal, this ratio is much higher, the majority of plants having a coal consumption of 6 lbs.; therefore, assuming 4 lbs. as the average, we get the relative efficiency as being 1 : 20. When very small quantities of heat are required and one momentarily, the electric heater is preferable and more economical than anything else.

Size of Wire Necessary to Carry a Given Current.

Required the size of wire necessary to carry 30 amperes at distance of 1300', allowing a loss of 5% at 100 volts.

By Ohm's law we have $C = \frac{E}{R}$ or $R = \frac{E}{C}$

Applying this to finding the resistance of the wire we get $R = \frac{5}{30} = \frac{1}{6}$ Ohm the total resistance of the whole circuit or 2600'. $\frac{1}{6}$ Ohm for 2600' = $\frac{1}{6} \times \frac{1}{20} = .064$ Ohms per 1000'.

By referring to the table given below we find that to be 000 wire. From the above we can deduce a formula, as follows:

$$R = \frac{L \times 1000}{C \times 2D}$$

where R = resistance per 1000'
 L = loss in volts
 C = total current
 D = single distance.

Another Example—Find size of wire necessary to carry 20 amperes a distance of 5000', allowing a loss of 8%. Voltage 2000.

$$R = \frac{8}{100} \text{ of } 2000 \times 1000 = .8 \text{ Ohm.}$$

No. 9 wire according to table has .811 Ohms, therefore No. 8 would be used.

The above rule is good for any system and any voltage.

TABLE OF RESISTANCES

SIZES, WEIGHTS AND LENGTHS OF COPPER WIRE.

Gauge No.	Size.		Weight and Length		Resistance.		Carrying Capacity, 2000 Amperes per sq.in.
	Diam. in Mils.	Dia. 2 or Circular Mils.	Pounds per 1000 feet.	Feet per Pound.	Ohms per 1000 feet.	Feet per Ohm.	
0000	460 000	211600.0	639.60	1.564	.051	19929.7	430
000	409.640	167804.9	507.22	1.971	.063	15804.9	262
00	364 800	133079.0	402.25	2.486	.080	12534.2	208
0	324 950	105592.5	319.67	3.133	.101	9941.3	165
1	289 300	83694.5	252.98	3.952	.127	7882.8	130
2	257.630	66373.22	200.63	4.994	.160	6251.4	103
3	229.420	52633.53	159.09	6.285	.202	4957.3	81
4	204 310	41742.57	126.17	7.925	.254	3931.6	65
5	181.940	33102.16	100.05	9.995	.321	3117.8	52
6	162.020	26250.48	79.34	12.604	.404	2472.4	41
7	144.280	20816.72	62.02	15.893	.509	1960.6	32
8	128.490	16509.68	49.90	20.040	.643	1555.0	26
9	114.430	13094.22	39.58	25.265	.811	1233.3	20
10	101.390	10381.57	31.38	31.867	1.023	977.8	16
11	90 742	8234.11	24.89	40.176	1.289	775.5	13
12	80 808	6529.93	19.74	50.659	1.626	615.02	10.2
13	71.961	5178.39	15.65	63.898	2.048	488.25	8.1
14	64 084	4106.75	12.41	80.580	2.585	386.80	6.4
15	57 068	3256.76	9.84	101.626	3.177	306.74	5.1
16	50 820	2582.67	7.81	128.041	4.582	243.25	4.0
17	45.257	2048.19	6.19	161.551	5.183	192.91	3.2
18	40.303	1624.33	3.786	203.666	6.536	152.09	2.5
19	35.390	1252.45	3.086	264.136	8.477	117.96	1.96
20	31 961	1021.51	2.448	324.045	10.394	96.21	1.60
21	28 462	810.09	1.942	403.497	13.106	76.30	1.28
22	25.347	642.47	1.539	514.933	16.525	60.51	1.08
23	22.571	509.45	1.221	649.773	20.842	47.98	.80
24	20.100	404.41	.967	819.001	26.284	38.05	.63
25	17.900	254.08	.768	1034.125	33.135	3.18	.50
26	15.940	201.49	.608	1302.083	41.789	23.93	.40
27	14.195	159.79	.484	1644.737	52.687	18.98	.31
28	12.641	126.72	.384	2066.116	66.445	15.05	.25
29	11.257	100.50	.302	2604.161	83.752	11.94	.20
30	10.025	79.71	.239	3311.258	105.641	9.466	.16

THE CHEMICAL EFFECT.

If we were told that a certain quantity of water—say, 100 gallons—had passed through a pipe, this by itself does not give us any idea of the force of the flow, or in an electrical sense the strength of the current. It might have taken a week to trickle through, or it might have passed in one minute; and according as the time is short or long, so is the force of the flow greater or less.

We must not only know the total quantity that has passed, but the time taken in its passage must also be known, to get a definite notion of the strength of the current. The current is the quantity of electricity that passes any part of the circuit in unit time, *i.e.*, one second, and the unit of quantity is called the *Coulomb*; the practical unit of current is called the *Ampere*, and coulomb per second = amperes.

The amount of chemical action at all points of the circuit are equal to one another. This does not mean that the same current passing for the same length of time through different solutions will decompose equal weights of the metals contained in these solutions, but that the weights of the metals so decomposed will be *chemically equal, i.e.*, the weight will be in direct proportion to the chemical equivalent.

The electro-chemical equivalent is the weight of a substance decomposed by the passage of one coulomb.

Let M = total mass in grams decomposed.

y = mass decomposed by 1 coulomb in grams = electro-chemical equivalent.

t = time in seconds.

C = current in amperes.

Formula, $C = \frac{M}{yt}$

$\therefore M = C.y.t.$

From this, we can calculate the consumption of zinc in a battery where the value of $y = .000337$. The weight consumed per cell = $Cty = Ct.000337$ grams per second, which is = $C \times 1.213$ grams per hour. If there are n cells the total weight of zinc consumed is =

$$\frac{nCty}{nCt.000337} = \text{weight in grams per second.}$$

No. in parallel = No. in parallel

The Chemical Effect

or Total weight consumed = $\frac{N.C \times 1.213}{\text{No. in parallel}}$ = grams per hour.

Total weight consumed in lbs. per hour. = $\frac{N.C \times 1.213}{\text{No. in parallel} \times 453.6} = \frac{N.C \times .002674}{\text{No. in parallel}}$

If all cells were in series, then the total weight consumed in lbs. per hour =

$W = n.C \times .00674$, and suppose we have a current of 746 amperes at 1 volt which is = 1 horse-power, and substitute this value for nC we get

$W = 746 \times .002674 = 2$ lbs. zinc at 1 volt.

Therefore for a higher E.M.F. the consumption of zinc would be inversely proportional to the E.M.F. or

Weight of zinc in lbs. = $\frac{\text{H.P. per hour} \times 2}{\text{E.M.F.}}$

no wire.

20 am-

No. 8

Carrying Capacity, 2000 amperes per sq.in.

430
262
208
165
130
103
81
65
52
41
32
26
20
16
13
10.2
8.1
6.4
5.1
4.0
3.2
2.5
1.06
1.60
1.28
1.08
.80
.63
.50
.40
.31
.25
.20
.16

By means of the following table the amounts deposited can be calculated when the current strength together with the time are known.

TABLE OF ELECTRO-CHEMICAL EQUIVALENTS.

ELEMENTS.	Valencies.	* Atomic Weight.	Chemical Equivalent	Electro-Chem. Equiv in Grams per Coulomb.
Aluminium	3	27.3	9.1	.00009449
Gold	3	196.6	65.5	.0006780
Silver	1	108.	108.	.0011180
Copper	2	63.	31.5	.0003261
Tin	4	118.	29.5	.0003054
Nickel	2	58.6	29.3	.0003054
Zinc	2	65.	32.5	.0003364
Hydrogen.....	1.	1.	1.	.000010352

The *atomic* weight is the weight of the atom, the weight of an atom of hydrogen being taken as 1. The atomic weight of copper is 63, *i.e.* 63 times heavier than hydrogen; but in chemical combination one atom of copper replaces 2 of hydrogen, hence the weight equivalent to 1 of hydrogen is $63 \div 2 = 31.5$. Therefore the atomic weight \div valency is = the chemical equivalent.

Example—A current of 2.5 amperes passes through a solution of gold for 20 minutes. What will be the total deposit?

According to the table the electro-chemical equivalent is = .0006780.

$$\therefore M = Cyt = 2.5 \times .0006780 \times 20 \times 60 \\ = 2.034 \text{ grams.}$$

Example—How long would it take to silverplate 6 spoons supposing the current was 1.5 amperes and that each spoon would take .125 grams of silver to cover it. Ans.—7 minutes nearly.

DYNAMO-ELECTRIC MACHINERY.

A dynamo-electric machine is a machine for converting energy in the form of mechanical power into energy in the form of electric currents, or *vice versa*, by the operation of setting conductors, usually in the form of coils of copper wire, to rotate in a magnetic field. (See Sylvanus P. Thomson's "Dynamo-Electric Machinery.")

Faraday in 1831 made the discovery that, by moving conductors in a magnetic field, electric currents are generated in them, and the principle of magneto-electric induction is as follows:

When a conductor is moved in a field of magnetic force so as to cut the lines of force, there is an E.M.F. produced in the conductor in a direction at right angles to the direction of motion, and at right angles also to the direction of the lines of force, and to the right of the lines of force, as viewed from the point from which the motion originates.

The induced E.M.F. is proportional to the number of lines of force *cut* per second, and is therefore proportional to the intensity of the "field" and to the length and velocity of the moving conductors.

As the volt is equal to 10^8 C.G.S. units, then the number of volts generated by a rotating armature is

$E = \text{Revs. per second} \times \text{No. of conductors in series around armature} = \text{Total lines of force which pass through the armature core, divided by } 10^8.$

$$\text{or } E = \frac{R.p.s \times \text{No. of cond.} \times \text{Flux}}{100,000,000}$$

By this we see that, to increase the E.M.F., we can do so by increasing the speed, or increasing the number of conductors, or increasing the lines of force, or all three of them could be increased.

The dynamo consists of two essential parts, viz., the field magnet and the armature. In the majority of continuous current machines the revolving part is the armature, and the field magnets are stationary.

There are several methods of exciting the fields, viz., by permanent magnets or electro magnets, self-excited or otherwise. Hence, the current of the generator may be itself utilized to excite the magnetism of the fields by being caused, wholly or partially, to flow round the field windings.

In the shunt wound dynamo, the field magnet is wound with a large number of turns of fine wire, and, being in shunt with the main current, only part of the whole current generated in the armature. The shunt machine is less liable to reverse its polarity than the series dynamo, and may be controlled so as to give a uniform E.M.F. by introducing a variable resistance into the shunt or field circuit.

When a shunt machine is supplying lamps in parallel, the turning on of additional lights reduces the resistance of the circuit and increases the current, but not in proportion, for when the resistance of the main circuit is lowered a little less current flows around the field windings and lessens the magnetism.

The series-wound dynamo consists of but one circuit. The majority of arc machines are series wound. The whole current from the armature is carried through the field windings, which are in series with the main circuit.

Any increase in the resistance of the series-wound dynamo lessens its power to supply current, because it diminishes the flux. When lamps are in series (as in the ordinary arc lighting), the switching on of an additional lamp both adds to the resistance of the circuit and diminishes the power to supply current. It requires the same expenditure of energy to magnetize an electro-magnet to the same degree whether shunt or series wound.

We see from the above that in the shunt-wound dynamo by turning on more lamps the E.M.F. is reduced, and in a series machine the switching on of additional lights, *if in multiple*, will increase the E.M.F., and by properly proportioning the series-winding and combining the two windings we could get a steady E.M.F. This is exactly what is done in the compound-wound machines.

ARMATURES.

If iron is employed in armatures it must be laminated so as to prevent Foucault current. Cores built up of varnished iron wire or of thin discs of sheet iron separated by varnish or paper realize this condition.

All needless resistance should be avoided in the armature coils, as hurtful to the efficiency of the machine. The wire therefore should be as short and as thick as is consistent with obtaining the requisite E.M.F. without requiring an undue speed of driving.

Since it is impossible to reduce the resistance of the armature coils to zero, it is impossible to prevent heat being developed in those coils while the machine is generating currents.

The insulation of the armature should be insured with particular care, and especially at the ends in drum wound armatures, where there are numerous crosses.

COMMUTATORS.

Approach being a finite process, the method of a coil approaching and receding from a magnet pole must necessarily yield currents alternating in direction. By using a suitable commutator, all the currents, direct or inverse, produced during recession or approach, can be turned into the same direction in the wire that goes to supply currents to the external circuits; and if the rotating coils are properly grouped so that before the E.M.F. in one set has died down, another set is coming into action, then it will be possible, by using an appropriate commutator, to combine their separate currents into one practically uniform current.—*Sylvanus P. Thomson.*

The commutator in direct current machines is the most troublesome part of the whole machine, and great attention should be paid to it, to have the brushes bearing at the proper angle, and in a bipolar machine set diametrically opposite.

THE NEUTRAL POINTS.

In consequence of the armature itself when traversed by the currents, acting as a magnet, the lines of force will not run straight across from pole to pole, but will on the whole assume an angular position, being twisted in the direction of rotation a considerable number of degrees. Hence the diameter of commutation, which is at right angles to the resultant lines of force, will be moved forward. In other words, the brushes will have a certain angular lead; this lead depending upon the relation between the intensity of the field and the current in the armature.

Hence, in all dynamos, it is advisable to have an adjustment, enabling the brushes to be rotated round the commutator or collector to the position of the diameter of commutation for the time being. If this is not done, there will be sparking at the brushes, and in part of the coils at least the current will be wasting itself by running against an opposing E.M.F.

EFFICIENCY.

The efficiency of a dynamo-electric machine is the ratio of the useful electrical work done by the machine to the total mechanical work applied in driving it. Every circumstance which contributes to wasting the energy of the current reduces the efficiency of the machine.

Electrical loss cannot be obviated entirely, because the very

best of conductors have some resistance. Mechanical friction of the moving parts should be brought to a minimum.

The mechanical efficiency of a dynamo = $\frac{\text{Internal Elect. H. P.}}{\text{H. P. in belt.}}$

when the Internal Electrical H. P. = $\frac{\text{E. M. F. in armature} \times \text{arm. current}}{746}$

Electrical efficiency of a dynamo = $\frac{\text{External Electrical H. P.}}{\text{Total Electrical H. P.}}$ when the

External Electrical H. P. = $\frac{\text{E. M. F. at terminals} \times \text{External current}}{746}$

and the total Electrical H. P. = power actually converted in the armature.

Thus, if it took, say, 3% of the total E.H.F. for the field winding and other 3% was wasted in heating the conductors of the armature, then the electrical efficiency will be 94% of the gross electric power.

Commercial efficiency of a dynamo = $\frac{\text{External Electrical H. P.}}{\text{H. P. in belt.}}$

In good machines this reaches higher than 90%, while the electrical efficiency is as high as 97%. Horse-power in belt = gross indicated horse-power of engine - engine friction. Deduct, roughly, 15% of mean pressure for friction.

The following has been selected from the instructions issued some years ago by the Edison Electric Co., and may be taken as fully covering the ground :

Location, Setting and Starting of Dynamos.

The dynamo should be located in a clean, dry place, and preferably in a room of low temperature.

The foundations should be of a substantial character, solid mason work or stout framing, sufficient to obviate all vibration while the machine is in operation.

The proper insulation of the dynamo from "earth" is vital. To secure this a stout frame of heavy timber is provided; this is secured to the foundation. The frame should be thoroughly treated with some moisture repellent such as asphalt varnish.

Exercise *great care* in handling the armature. Use only rope slings and wooden bars.

Handle as much as possible by the shaft.

Never, under any circumstances or in any manner, make use of the commutator in handling the armature.

Do *not* allow the weight of the armature to rest on it for a moment.

Never lay an armature down unless you have a thick, soft pad between it and the floor.

It is quite important that before a new dynamo is put at steady work it should be run for a few hours first at slow speed, which may be gradually increased to the maximum. During this trial run, carefully attend to the bearings. Make sure that everything is in perfect condition previous to putting the dynamo at work on the circuit.

Cleanliness about the Dynamo.

All parts of the dynamo should be kept neat and clean. Dirt, copper dust and oil should not under any circumstance be allowed to gather on any part.

Never allow loose articles of any kind to be placed upon any portion of the dynamo.

Adjustment of Brushes.

In order to maintain the commutator in proper condition and reduce the wear to a minimum, it is vitally necessary that a proper adjustment of the brushes be secured. They should work absolutely free from sparks. Any sparking whatever indicates a bad condition of the commutators or defective adjustment of the brushes.

The end of the brush should be carefully bevelled so as to conform accurately with the surface of the commutator. The brush should bear lightly upon the commutator, and every part of the bevelled end should rest upon it. The pressure should be just sufficient to ensure good contact, and avoid all cutting and scratching.

One of the worst causes of sparking is lack of pressure of the brush, caused by improper setting of the brush-holder stud or by allowing a brush to wear too short. To maintain the proper angle, the brush as it wears must be pushed forward in the holder from time to time.

A dynamo in operation with sparking brushes is *prima facie* evidence of carelessness or ignorance on the part of the attendant, and such a condition of affairs should not be tolerated under any circumstances.

Causes of Sparking.

Brushes not set at neutral point.

Brushes not set at diametrically opposite points.

Brushes set so as not to get full bevel to the circumference of commutator.

Brushes set with insufficient pressure.

Brushes spread apart and filled with oil and dirt.

Commutator bars loose, high or low.

Loose connection between armature coil and commutator bar.

Section short circuited either in commutator or armature coils.

Armature damp, with consequent short circuiting of coils.

Short circuit or cross on outside system.

Commutator dirty, oily, rough worn in ridges, or out of truth.

Dynamo overloaded.

Armature coils or commutator sections short circuited by accumulation of copper dust.

N.B.—An examination of some dynamos would lead one to believe the machine was constructed for the purpose of producing copper dust. The accumulation of copper dust on a dynamo, and its gradual penetration into the armature and field coils, is often the real cause of serious accident and expensive repairs. This is one of the principal features which denotes carelessness and inefficient management, and an utter lack of appreciation of the importance of cleanliness about dynamos and electrical apparatus. The remedy is easy to apply; the dynamos *must* be kept clean of oil and copper dust.

The following are some of the disorders which dynamos are subject to :—

Burning Out an Armature Coil.—This may be occasioned by overloading the armature, causing the insulation of the coils to give way, and is indicated by the armature suddenly beginning to smoke. The coil is thus rendered useless. As a temporary make-shift, the injured coil may be disconnected from the commutator, the ends insulated with tape and the two adjacent bars to which the coil was connected joined to each other by a wire not less than the armature wire. The machine can be operated for a time in this way, but it should be repaired at the first opportunity.

Ring of Fire Around the Commutator.—This is caused by small particles of copper between the bars of the commutator, making a local short circuit from bar to bar across the mica insulation. Clean the commutator carefully and do not allow the brushes to cut and scratch it.

Breaking Down of one Dynamo.—If one dynamo of a single pair connected in series on a 3-wire system breaks down, the result will be merely to put out the lights on that side of the system. If, however, other machines are in multiple with the disabled one, the current through the armature will be reversed, and if not disabled electrically will run as a motor. Cut the machine out at once.

Reversal of Polarity of Magnets.—Reversal of polarity of a dynamo which is one of two or more connected in multiple is equivalent to a dead short circuit and if it does not blow the fuses or circuit breaker, or throw off the belt, will probably burn the armature out.

Reversal of polarity of one of a single pair of dynamos working in series on a 3-wire system, will tend to send all the current through the central wire, which will cause the lights to burn dim.

More trouble will be caused by switching in a reversed machine with another that is not reversed.

Dynamos on the 3-wire system may be reversed under the following conditions :

A reversal sometimes occurs when starting up, caused by the influence of another dynamo in close proximity to it.

Reversal may be caused by the current of the second dynamo in series while in operation, if the brushes of the first dynamo are raised or its current broken in any way between the points to which the field circuit is connected.

By lifting the brushes before throwing out the switch.

By burning out the safety catches on some other dynamos.

By crosses on the line.

By 200-volt motors. This is more apt to occur during a light load when the motor is thrown on with a heavy load.

To correct the polarity, open the circuit switch, raise the brushes, throw in dynamo switch on the side not reversed and leave it about a minute.

Effects of Lightning.

One of the safest places to be in during a thunder-storm is in an electric light station.

In underground systems no effects of lightning are felt, but where there are long out-door pole lines the same effects occur as on telegraph and telephone lines, and certain precautions must be taken to prevent injury to apparatus.

Lightning arrests should be in plain sight. Fuses on such arresters must be promptly replaced, and ground wires and connections must be kept intact and in good condition.

Facts to be Remembered.

Be sure that the speed of the dynamo is right.

Be sure that all belts are sufficiently tight.

Be sure that all connections are firm and make good contact.

Keep every part of the machine and dynamo room scrupulously clean.

Keep all the insulations free from metal, dust and gritty substances.

Don't allow the circuit to become uninsulated in any way.

Keep all bearings of the machine well oiled.

Keep the brushes properly set, and see that they do not cut or scratch the commutator.

If brushes spark, locate the trouble and rectify it at once.

Before throwing dynamos in circuit with others running in parallel, be sure the pressure is the same as that of the circuit, then close the switch.

Be sure each dynamo in circuit is so regulated as to have its full share of the load, and keep it so.

ELECTRIC MOTORS.

Any dynamo can be run as a motor, and the instructions given above regarding dynamos are applicable to motors.

In the dynamo only one E.M.F. exists, whereas in the motor there must be two, viz., the E.M.F. of supply and the counter E.M.F.

In the dynamo the current flowing through the armature is = $\frac{E}{R}$ where R is the total resistance of the circuit. With the motor the current flowing is = $\frac{\text{E.M.F. of supply} - \text{counter E.M.F.}}{R_1}$ where R_1 is the resistance of the armature.

$$5 \text{ kilowatt dynamo } C = \frac{E}{R} = 25 \text{ amperes} = \frac{200 \text{ volts}}{8 \text{ Ohms}}$$

$$5 \text{ " motor } C = \frac{\text{E.M.F.} - \text{coun. E.M.F.}}{R_1} = 25 \text{ amperes} = \frac{200 - 180}{.8}$$

From this, we see that the current and the E.M.F. is the same in both cases, but the resistance of the motor circuit is one-tenth that of the dynamo, the difference being made up by the counter E.M.F., which has the same effect as resistance. The ratio of the E.M.F. of supply to the counter E.M.F. is the electrical efficiency of the motor.

INDEX TO ADVERTISEMENTS.

Abell Engine & Machine Works Co., The John, Limited	28
Aikenhead Hardware Co.	40
Bennett & Wright Co., The, Limited	22
Boiler Inspection & Insurance Co. of Canada, The	32
Booth Copper Co. of Toronto, The, Limited,	48
Burns & Co.	20
Canadian Heine Safety Boiler Co.	14
Canadian Rubber Co., The	12
Conger Coal Co., The, Limited	Fly Leaf A
Coulter & Campbell	50
Dodge Wood Split Pulley Co.	4
Eureka Mineral Wool & Asbestos Co.	62
Fensom Elevator Works, The	Front Inside Cover
Fetherstonhaugh & Co.	24
Foulds & Co.	28
Goldie & McCulloch Co., The, Limited	36
Grand Trunk Railway System	18
Grant & Co., Geo. W.	54
Gurney Foundry Co., The	133
Gutta Percha & Rubber Mfg. Co. of Toronto, Limited	Back Cover
Harris Co. of Toronto, The E., Limited	129
Harris, W. G.	8
Hutson & Sons, W. D.	153
Johnson Electric Co., W. A.	127
Kay Electrical Mfg. Co.	135
Kellond & Co.	10
Leitch & Turnbull	131
Luxfer Prism Co., Limited	64
McLean, R. G.	137
Malcolm & Co.	44
Meadows, Geo. B.	40
Meyer Bros.	54
Mica Boiler Covering Co., Limited	60
Morrison Brass Mfg. Co., The James, Limited	30
Murton Coal Co. of Hamilton, The, Limited	135
Northy Mfg. Co., The, Limited	2
O'Keefe Brewing Co. of Toronto, The, Limited	48
Pendrith & Co.	26
Petrie, H. W.	127
Polson Iron Works, The	16
Queen City Oil Co., The, Limited	Fly Leaf B
Rice Lewis & Son, Limited	42
Riches, C. H.	152
Robb Engineering Co., Limited	52
Rogers Co., The Elias, Limited	56
Royal Electric Co., The	125
Royal Oil Co.	150
Sadler & Haworth	66
Shales, John H.	26
Standard Fuel Co. of Toronto, The, Limited	34
Spilling Bros.	68
Spooner, Alonzo W.	10
Sutton Compound Co., Wm., Limited	58
Temperance & General Life Assurance Co., The	6
Toronto Electric Motor Co.	129
Toronto Radiator Mfg. Co., The, Limited	154
Vacuum Oil Co.	24
Walker, G. Hawley	68
Weeks-Eldred Co., The, Limited	38
Westman & Baker	46
White-Fraser, George	44
Williams Machine Co., The A. R., Limited	34
Wilson & Co., William C.	76

ROYAL OIL COMPANY,

TORONTO AND MONTREAL.

HEADQUARTERS FOR

CYLINDER OILS,
ENGINE OILS,
LUBRICANTS.



High Class Oils a Specialty.



WISHING THE BOYS WHO RUN THE
MACHINES ALL PROSPERITY.



Royal Oil Company.

GEORGE ANDERSON, Manager.

. . INDEX . .

	PAGE.
Acceleration Due to Gravity,	100
Algebra,	15
Ammonia Table of Properties,	113
Areas of Circles,	51
" " Segments of a Circle,	41
Arithmetic,	11
Arithmetical Progression,	23
Armatures,	143
Belting,	67
Belts, Horse-power Transmitted by	116
Boilers, Care of	81
" Foaming in	59
" Settings	85
" Shells, Strength of	107
Brake, Horse-power	115
Chemical Effect, The	141
Circumference of Circles	55
Commutators,	144
Covering for Boilers and Steam Pipes,	61
Current, Division of	132
" Heating of	136
Decimals,	13
Dynamo—Electric Machinery,	142
Dynamos, Causes of Sparking,	146
" Location, Setting and Starting	145
Effects of Lightning and Facts to be Remembered,	147
Electric Motors,	148
Electrical Units of Measurement,	132
Electricity,	128
" Heating by	139
Electro-Chemical Equivalents, Table of	142
Engine, Duty of an	115
" How to Set up a Stationary	101
" To Place on the Dead Centre,	121
Evaporative Tests,	85
Evolution,	25
Feedwater, Heating of	90
Flywheel, Energy and Bursting Stress,	117
Fractions,	11
Geometrical Progression,	25
Geometry, Practical	29
Horse-power, Rules for Determining	114-134
Injector, The	89
Mean Pressure, Graphic Method of Finding	80
Mechanical Refrigeration and Ice Making,	111
" Stoker,	38

INDEX.--Continued.

	PAGE.
Mensuration of Solids,	49
" " Surfaces,	29
" Of Interest to Engineers,"	124
Pendulum, The	97
Polygons, Table of Regular	35
Pulleys--Rules for Calculating Size and Speed,	95
Pumps,	91
Quadratic Equations,	23
Resistance, Derived Circuits of	130
Resistances, Table of	140
Riveted Joints,	103
Safety Valve, The	122
Screw Cutting,	96
Shafting, Strength of Solid Round	93
" Power Transmitted by	94
Stays,	108
Steam,	71
" Expansion of	75
" Properties of Saturated	73
Useful Information,	65
Valve Setting,	120
" " Duplex Pump,	93
Water at Different Temperatures,	109
Wire--Size Necessary to Carry a Given Current,	139
Zeurner's Diagram,	119

Chas. H. Riches & Co.,

SUCCESSORS TO

DONALD C. RIDOUT & CO.,

CANADA LIFE BUILDING,

TORONTO, CANADA.

**Solicitors of Patents, Counsellors and Experts in
Patent Causes, Specialists in Electrical
and Mechanical Matters.**

PATENTS OBTAINED IN ALL COUNTRIES.

W. D. HUTSON & SONS,

OFFICE: 21 QUEEN ST. EAST,
COR. VICTORIA ST.

TELEPHONE
1694.

...TORONTO, Ont.

..ROOFING

FLAT SURFACE SLATE, TILE AND
GRAVEL ROOFING.

Slate, Tile, Copper, Galvanized Iron, Tin
and Gravel.

Fine Lake Gravel supplied for
Walks and Drives.



A FEW BUILDINGS THROUGHOUT ONTARIO ROOFED BY US :

Freehold Loan Building,	Toronto.	Post Office,	Chatham.
Methodist Tabernacle,	"	Court House,	Ogdensburg, N.Y.
Pharmacy College,	"	High School,	Brockville.
Foresters' Temple,	"	Baptist Church,	"
Town Hall,	Almonte.	Military College,	Kingston.
High School,	Perth.	St. George's Cathedral,	"
Church,	Prescott.	St. Mary's Cathedral,	"
Church,	Gananoque.	Parliament Library,	Ottawa.
Post Office,	Port Hope.	Supreme Court,	"
Post Office,	Peterborough.	City Hall,	"
Post Office,	Niagara.	Toronto Paper Mfg. Co.,	Cornwall

PAGE.
49
29
124
97
35
95
91
23
130
140
103
122
96
93
94
108
71
75
73
65
120
93
109
139
119

O.,

G,

ts in

IN USE EVERYWHERE.

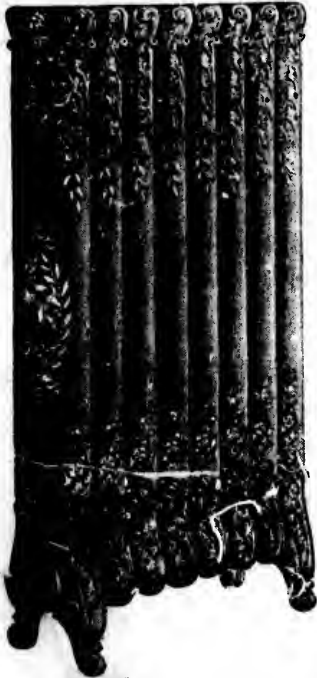

“Safford”

QUEEN OF

Radiators

ARE THE WORLD'S STANDARD FOR

HOT WATER

AND

STEAM HEATING.

The Only Radiators in Canada made without
Rods or Bolts, and Never Leak.

FULL PARTICULARS FROM THE

Toronto Radiator Manuf'g Co., Limited,

TORONTO, ONT.

**THE LARGEST RADIATOR MANUFACTURERS UNDER
THE BRITISH FLAG.**

ROOM
449

"PYRAMID" BRAND



BLUESTONE HIGH PRESSURE PACKING

For Steam, Hot or Cold Water and Air.
Packs equally well for all. There is no
Packing made that will last as long or
withstand as well the action of Steam
Heat. Write for prices

The Gutta Percha & Rubber Manfg. Co.

of Toronto, Limited,

SOLE MANUFACTURERS,

61-63 Front Street West, TORONTO, CANADA.

E.
"
S
RD FOR
R
ING.
thout
ited,
NDER

