

**CIHM
Microfiche
Series
(Monographs)**

**ICMH
Collection de
microfiches
(monographies)**



Canadian Institute for Historical Microreproductions / Institut canadien de microreproductions historiques

© 1998

The copy filmed here has been reproduced thanks to the generosity of:

National Library of Canada

The images appearing here are the best quality possible considering the condition and legibility of the original copy and in keeping with the filming contract specifications.

Original copies in printed paper covers are filmed beginning with the front cover and ending on the last page with a printed or illustrated impression, or the back cover when appropriate. All other original copies are filmed beginning on the first page with a printed or illustrated impression, and ending on the last page with a printed or illustrated impression.

The last recorded frame on each microfiche shall contain the symbol \rightarrow (meaning "CONTINUED"), or the symbol ∇ (meaning "END"), whichever applies.

Maps, plates, charts, etc., may be filmed at different reduction ratios. Those too large to be entirely included in one exposure are filmed beginning in the upper left hand corner, left to right and top to bottom, as many frames as required. The following diagrams illustrate the method:

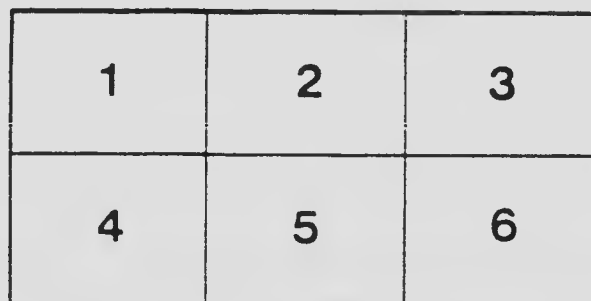
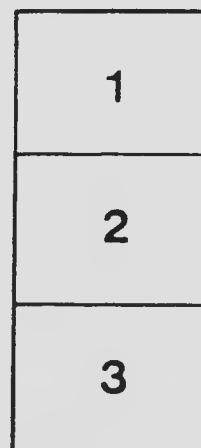

L'exemplaire filmé fut reproduit grâce à la générosité de:

Bibliothèque nationale du Canada

Les images suivantes ont été reproduites avec le plus grand soin, compte tenu de la condition et de la netteté de l'exemplaire filmé, et en conformité avec les conditions du contrat de filmage.

Les exemplaires originaux dont la couverture en papier est imprimée sont filmés en commençant par le premier plat et en terminant soit par la dernière page qui comporte une empreinte d'impression ou d'illustration, soit par le second plat, selon le cas. Tous les autres exemplaires originaux sont filmés en commençant par la première page qui comporte une empreinte d'impression ou d'illustration et en terminant par la dernière page qui comporte une telle empreinte.

Un des symboles suivants apparaîtra sur la dernière image de chaque microfiche, selon le cas: le symbole \rightarrow signifie "A SUIVRE", le symbole ∇ signifie "FIN".

Les cartes, planches, tableaux, etc., peuvent être filmés à des taux de réduction différents. Lorsque le document est trop grand pour être reproduit en un seul cliché, il est filmé à partir de l'angle supérieur gauche, de gauche à droite, et de haut en bas, en prenant le nombre d'images nécessaire. Les diagrammes suivants illustrent la méthode.

MICROCOPY RESOLUTION TEST CHART

ANSI and ISO TEST CHART No. 2



45

5.0

5.6

6.3

7.1

8.0

9.0

10

11.2

12.5

14.3

16

18

20

22.5

25

28

32

36

40

45

5.0

5.6

6.3

7.1

8.0

9.0

10

11.2

12.5

14.3

16

18

20



APPLIED IMAGE Inc

1653 East Main Street
Rochester, New York 14609 USA
716-482-0300 - Phone
716-482-5989 - Fax

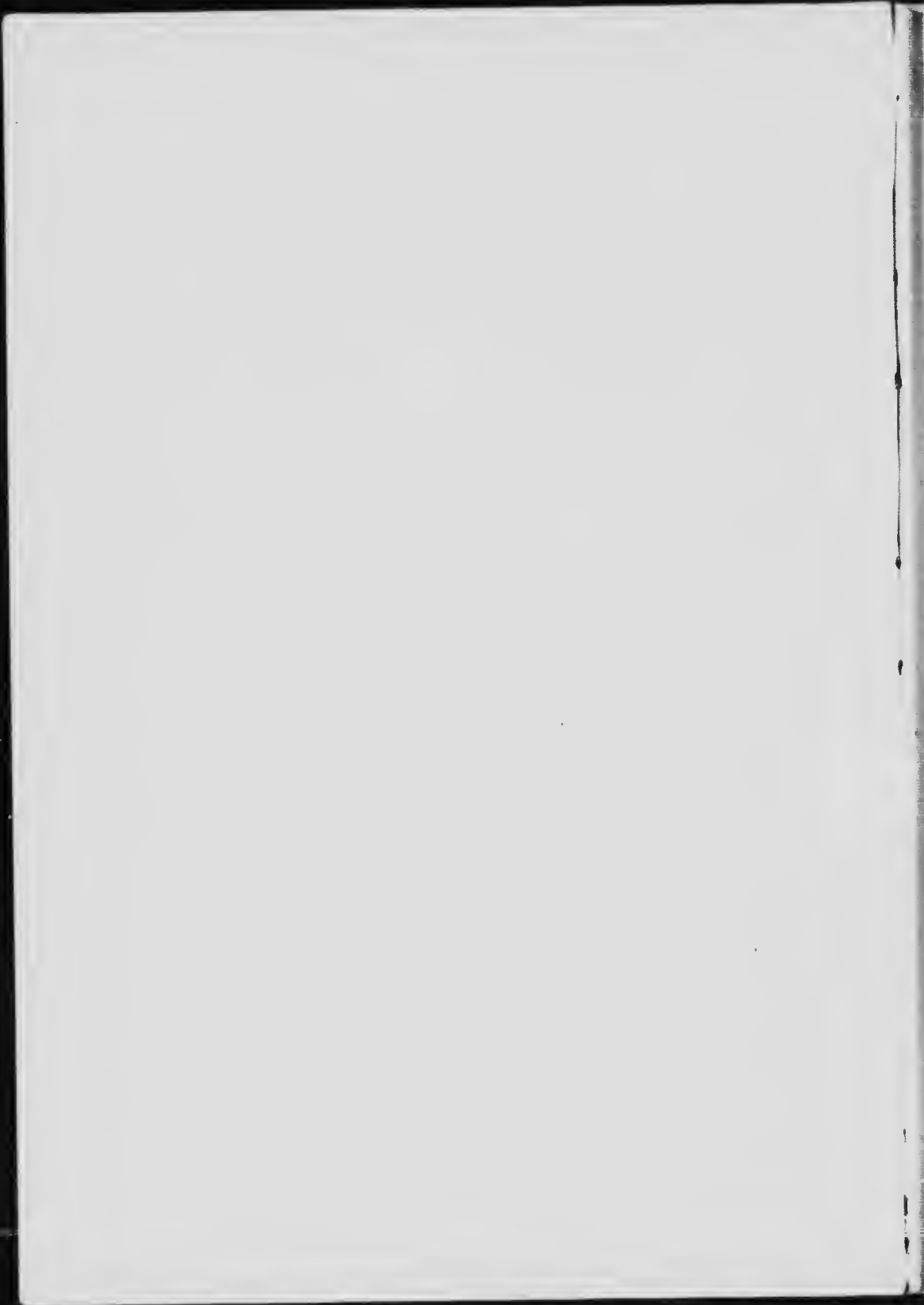

THE
Builders' and Contractors' Guide
TO
Correct Measurements

BEING A PRACTICAL TREATISE ON THE MOST CORRECT, SIMPLEST, AND MOST APPROVED METHODS OF OBTAINING AREAS AND CUBIC CONTENTS OF ALL KINDS OF BUILDERS' WORK, AND SUITED TO THE EVERY-DAY WANTS OF STONE-MEN, BRICKLAYERS, CARPENTERS, PAINTERS, TINNERS, CONCRETORS, ESTIMATORS, ROOFERS, TILERS, PLUMBERS, AND ALL WHO ARE ENGAGED IN THE BUILDING TRADES, SHOWING HOW ALL SORTS OF INTRICATE MEASUREMENTS MAY BE READILY TAKEN

BY
FRED T. HODGSON, ARCHITECT, M. O. A. A.,
AND
W. M. BROWN, C. E. AND QUANTITY SURVEYOR

Fully Illustrated with Explanatory Diagrams and Sketches



CHICAGO
FREDERICK J. DRAKE & COMPANY
PUBLISHERS
1906

T-425

H-44

1805

1-2-2

COPYRIGHT, 1906
BY FREDERICK J. DRAKE & CO.
CHICAGO



AUTHORS' PREFACE

To ascertain accurately the cost of buildings proposed to be erected, and the separate values of the different artificers' work, it is essential that a system of measurement be adopted. When an uniform system has been introduced into a country or any district, it gives a proper basis for each contractor to figure out his estimate. The present treatise is intended to meet this demand by formulating a system which has been practised for many years by me in my profession as a quantity surveyor and estimator in a large city. The advantages of this system are accuracy and minuteness of detail, which give the nearest value possible that would be satisfactory to proprietor and contractor. The various artificers' work shall be treated separately, showing the methods of measuring each and making out the measurements of same.

W. M. BROWN.

Assisted by Fred. T. Hodgson, Architect.

COLLINGWOOD, ONT., Aug. 1, 1906.

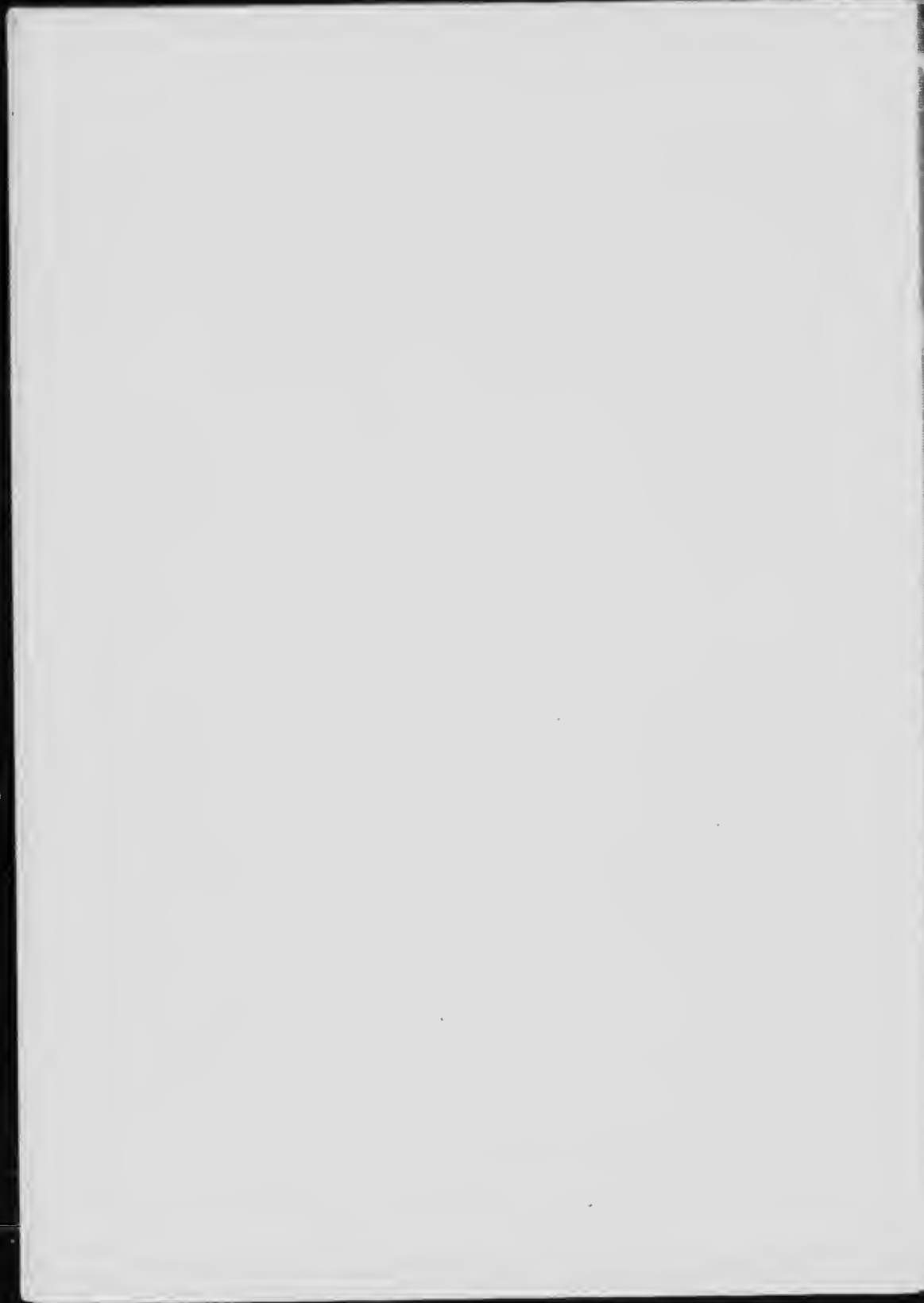

PART ONE

RULES FOR MEASUREMENT OF MA WORK

(1) Foundations (other than rubble) for walls to be measured by the cubic foot where 12 inches thick or upwards; and where under 12 inches thick, to be measured by the superficial foot, stating thickness. Foundations for columns and pillars to be classed separately, according to size. The prices shall include materials, dressing, and building, but preparing for sole plates to be charged separately.

Thus in the first instance a stone 12'0" long, 2'0" broad, and 18" thick, to be calculated:

12-0
2-0
<u>24-0</u>
1-6
<u>24-0</u>
12-0
<u>Cubic feet 36-0</u>

In the second instance, foundations under 12" thick, thus:

10" Foundation of wall, 12'0" long by 2'0" broad.....	12-0
	2-0
Superficial feet	<u>24-0</u>

Foundations for columns and pillars to be classed separately, thus:

Foundations for 3 columns each.....1'6"×1'6" and 3'0" high

The prices shall include materials, dressing, and building, but preparing for sole plates shall be charged separately.

(2) Building of every description—with exceptions hereafter stated—shall be first measured as rubble by the superficial yard, and classed according to style of work and quality of materials.

The exceptions are: Cube columns and pillars not connected with rubble, cornices in one or more leaves, anyone of which goes through full thickness of walls, and other courses going through full thickness of walls, mullions, transoms, tracery, skews, chimney stalks, newels, parpend ashlar walls, steps, platts, pavement, hearths, shelves, skirtings, border stones, copings on walls; and which shall be held to include building and laying, and shall not be measured as rubble.

(3) Two feet shall be the standard thickness of building. Walls exceeding that thickness shall be reduced to it; and those under two feet thick shall be classed according to their respective thicknesses. Thus in the first instance a wall varying in thickness at different heights is measured in the following manner:

Rubble wall above foundation.....	$2-10 \times 47-0 \times 9-0 =$	66-5-3
Rubble wall above 2'10" thickness.....	$2-6 \times 47-0 \times 10-0 =$	65-2-6
Contents of 2'0" work in superficial yards		<u>131-7-9</u>

These foregoing calculations are divided by 2 to bring them to the standard thickness of 2 feet, after being multiplied by each other, and then divided by 9 to give the contents in superficial yards, thus:

47.0		47.0
9.0		10.0
423.0		470.0
2.10		2.6
846.0		940.0
352.6		235.0
2)1198.6		2)1175.0
9) 599.3		9) 587.6
Superficial yards 66-5-3	Superficial yards	65-2-6

(4) Walls shall be measured net, without girding, either in length or height. Gable tops and pediments shall be taken the average width within the skewers by the perpendicular height, or in such a manner as will ascertain the net superficial area.

Thus in the measurement of pediments the half of the base by the perpendicular height gives the net superficial area, in this instance,

$$8.0 \times 8.0 = \text{superficial feet } 64.0$$

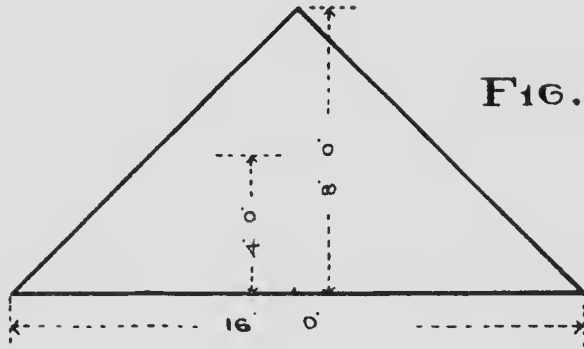

The projections of such continuous cornices, mouldings, and belts as are measured for rubble shall be reduced to the thickness of the walls with which they are connected. Thus:

2'0" Rubble wall above foundation to top of cornice.....	$130-0 \times 46-0 = 664-4-0$
2'0" Rubble work in projection of moulded course.....	$6" \times 130-0 \times 0-4 = 1-1-10$
2'0" Rubble work in projection of cornice on wall head.....	$12" \times 130-0 \times 0-10 = 6-0-2$
	<u>Superficial yards 671-6-0</u>

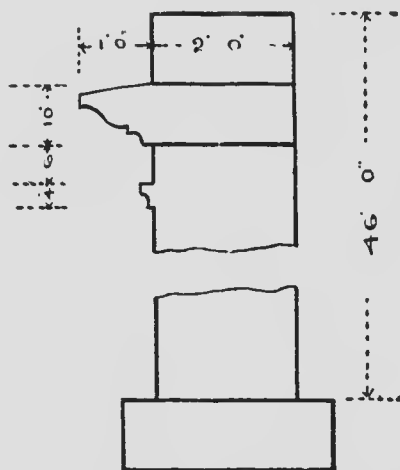

FIG. 2.

NOTE.—The calculations of the projecting courses to be divided by 2 after being multiplied, to bring them to 2 feet work, the thickness of wall.

All circular and oriel walls to be measured on the outside circumference, and classed to their respective thicknesses, in every other respect they shall be measured as stated for straight work.

The daylight size of all openings with their mullions, transoms, and tracery to be deducted from the building. No deduction to be made for vents, but thin parts of walls, such as window bossings, wall presses, and other recesses shall be deducted from main walls, and classed according to thickness.

(5) Levelings and beam filling.—No allowance to be made for levelings of any kind, except for bond timbers, which shall be charged by the lineal foot. Beam filling at wallheads shall be measured by the lineal foot, stating thickness and height, and cuttings on common rubble shall be measured by the lineal foot.

(6) Scuncheons and angles.—The hammer dressed scuncheons at sides of openings (not having hewn dressings) window bossings, wall presses, other recesses, and exposed ends of detached walls shall be measured by the lineal foot of height and classed according to their quality and breadth. The inside scuncheons of openings having hewn dressings shall be included with said dressings.

The hammer dressed corners under surface, and at angles inside of walls, to be measured by the lineal foot of height.

(7) Vents and vent linings to be measured by the lineal foot, from the top of the oncome to the bottom of the stalk; the cutting of vents through cube stone to be charged separately; and oncomes, whether built or fire clay, shall be enumerated. Recesses formed or cut in walls for soil pipes and conductors shall be measured by the lineal foot.

(8) Pointing of exposed face of common rubble walls shall be measured by the superficial yard, the daylight of openings being deducted.

Square dressed rubble shall be measured by the superficial yard for extra value over common rubble, and classed according to quality.

Coursers and Ashlar shall be measured by the super-

ficial foot for extra value over common rubble, and classed according to quality.

The exposed surface only shall be measured for square dressed rubble, coursers, and ashlar; and all openings, with whole size of face of rybats, sills, lintels, corners, and other dressings, shall be deducted. The cover of facing at internal angles shall be charged by the lineal foot of height. The cuttings at all angles and circles shall be measured by the lineal foot for labor and waste of material.

Rustic work shall be measured as plain surface, without girding, and the channels shall be described and measured by the lineal foot.

In all cases where facing of walls is checked or curved and where headers are required at upstarts and pilasters, the same shall be described and measured by the lineal foot.

(9) Principal stones not less than 12 inches thick, and the breadth of which does not exceed twice the thickness, nor the length twice the breadth, shall be measured by the cubic foot and classed according to their contents, viz:—under 15, 20, or 25 cubic feet, and so on progressively.

Stones more than 21 inches in breadth, and the breadth of which exceeds twice the thickness, shall be measured by the superficial foot, and classed according to their thickness and contents.

Stones other than these two classes, and above 14 inches by 9 inches, shall be measured by the lineal foot, and classed according to breadth and thickness, and also according to length where it exceeds 4 feet.

(10) Hewing of principal stones, so far as exposed, to be measured by the superficial foot, and classed according to quality. The extreme length of returns at external and internal angles of moulded work shall be taken, and all mitres enumerated. The hewing of top bed of cornices and other mouldings, where 12 inches broad and upwards, shall be measured and classed separately. Scabbled and broached hewing on sides of shop piers shall be measured by the superficial foot.

(11) Stones 14 inches by 9 inches and under shall be measured for material and hewing by the lineal foot, stating size of stone and girth of hewing, and classed according to length, where it exceeds 4 feet. Belt, string, and similar courses shall be measured extreme length of moulding, and the mitres enumerated.

(12) Corners and rybats to be measured by the lineal foot of height, stating size of stone, description of labor, and girth of hewing; the rybats being girded to bottom of check.

(13) Sills and lintels to be measured as principal or lesser stones, the length for hewing to be taken same as length of stones, and girth of hewing for sills shall be taken six inches inward from check, or as far as hewn, and for lintels to bottom of check. When plain sills project, one projection shall be added to the length and the return ends of moulded sills and arcitrave sills, also footings and reprises, shall be enumerated. All labor on face to be described, and included in the prices of sills and lintels.

(14) Working beds and joints of stones shall, in all cases, be included in the price of the stone.

(15) Circular hewn work shall be measured in the same manner as straight work, but classed separately; the full size of stone required to work circle shall be stated.

(16) Stones in arches over openings shall be measured at their extreme sizes, and charged by the cubic or superficial foot. The plain hewing shall be measured net by the superficial foot; and moulded hewing shall be measured at the outer circumference of each ring for length, and charged by the superficial foot.

(17) Vaulted and barrel arches shall be measured at their largest circumference, and classed according to their thickness and quality. Where groins occur, they shall be measured by the lineal foot of groin, and charged separately for labor and waste of material.

(18) Chimney stalks of ashlar, coursers, or square dressed rubble shall be girded and charged by the superficial foot, the price to include forming fair face on inside and building, the briggs (divisions) of vents shall be described and measured by the lineal foot of height, and vent linings shall be charged extra. All cornices and plinths under copes shall be measured by the lineal foot, stating size of stone and girth of hewing, the price to include forming fair face on inside and building. All plain and moulded copes not above 12 inches thick shall be measured by the lineal foot, stating size of stone and girth of hewing, and the return ends shall be measured or enumerated; but if above 12 inches thick, they shall be measured by the cubic foot for stone, and the hewing shall be measured by the superficial foot. In all cases

the price of copes shall include building; and the perforating of copes for vents shall be measured or enumerated.

(19) Room chimney jambs and lintels shall be charged by the set, according to quality. Kitchen and laundry jambs and lintels shall be charged separately in detail, stating the size of both jambs and lintels. The jambs, sills, and lintels of safe presses in walls shall be measured by the lineal foot, stating size of stone and girth of hewing.

(20) Hearths shall be measured at extremes, and charged by the superficial foot. When front and back hearths are in one stone, the checking shall be enumerated per hearth.

(21) Platts shall be classed according to size and quality, and rated by the superficial foot; the full length and breadth of stones shall be taken, except in the case of platts formed on winding steps, where the breadth shall be taken in the center. The hewing on edge and underside of platts shall be measured net for labor only. Steps shall be charged by number; according to size and quality, the length being stated clear of wall hold, which shall be understood to be $4\frac{1}{2}$ inches for resting steps and 9 inches for hanging steps, unless otherwise specified.

(22) Newels and perpendicular ashlar walls shall be measured for stone by the superficial foot, stating the thickness, the hewing being charged separately.

(23) Pavement shall be measured at extremes and charged by the superficial yard; and a separate charge by the lineal foot shall be made for cuttings at angles or circles.

(24) Skirting, whether level or raking, shall be measured by the lineal foot, stating the breadth and quality.

(25) Coping and skews on walls, also border and gutter stones, shall be measured by the lineal foot, and classed according to their size and quality, the girth of hewing to be stated where requisite.

(26) Fire clay drain pipes to be measured by the lineal yard and classed according to their size and quality; bends, eyes, and other connections shall be charged extra. In all cases the price shall include digging and refilling track 3 feet in depth or less; where the depth of track exceeds 3 feet, the actual depth shall be stated and charged extra. Cesspools and traps to be described and enumerated. Built sewers shall be measured by the lineal yard, and classed according to size and quality; connections with old drains and sewers shall be charged separately.

(27) Taking delivery, carrying in, and setting iron beams and lintels to be classed according to length and weight, and charged by the lineal foot; columns and mullions at a price for each, according to size and weight.

(28) Dooking walls for strapping shall be measured by the superficial yard. Dooking for window stanchions shall be charged per window. Cutting raggles for lead or slates shall be measured by the lineal foot.

(29) Cutting batt holes, socketing for stair railings, perforating walls for water, gas, and drain pipes, and executing all other jobbings required by the carpenters, plumbers, and other tradesmen employed at the buildings, shall be charged as a separate item.

(30) Furnishing, lighting, and upholding lamps shall be charged as a separate item.

(31) In all cases the plumbing of rybats and scuncheons, building or filling up savings, forming washings on bases and sills, and all matters of a similar description required to complete the work as represented on the drawings, or described in the specification, also supplying water, shall be held to be included in the prices of the work.

(32) All ordinary scaffolding, planks, tresses, and gangways shall be provided by the contractor for wright work, but these shall be set up and shifted as required by the contractor for mason work; and all gabbart scaffolding shall be provided, erected, and altered from time to time by the contractor for wright work. But all cranes and crane seats, also all tackling and other appliances requisite for conducting the work, shall be furnished by the contractor for mason work, and shall be held to be included in the prices of the work.

(33) The foregoing Rules and Regulations shall be held as generally applicable to the measurement of all work, whether materials and workmanship are wholly or only partially furnished by the contractors; and likewise, when partial or sub-contracts are made for workmanship, cartage, quarrying, furnishing of lime, and such like; so that the same quantities shall apply throughout the whole departments of the work.

RULES FOR MEASUREMENT OF BRICK WORK

- (1) Foundations shall be measured by the cubic yard
- (2) Walls shall be classed according to the number of bricks in their respective thicknesses, and measured by the superficial yard.
- (3) Hollow walls to be stated at their full thickness, giving the outer and inner thicknesses respectively and width of space between, also mode of tying, and number of ties, and classed separately from ordinary work by the superficial yard.
- (4) Walls shall be measured net without girding either in length or height. Gable tops and pediments shall be taken the average width within the skews, by the perpendicular height, or in such a manner as will ascertain the net superficial area.
- (5) The rojections of chimney breasts, pilasters, and butts shall be measured with the walls to which they are built and reduced to the same thickness as the wall.
- (6) The projections of brick, continuous cornices, mouldings, and belts shall be reduced to the thickness of walls with which they are connected.
- (7) All circular, octagonal, and oriel walls to be measured on their outside circumference, or extreme length, and classed according to their respective thicknesses, in every other respect they shall be measured as stated for straight work.

(8) The daylight size of all openings to be deducted. No deduction to be made from brick walls for stone, bond timbers, joists, lintels, fireplaces, vents, or ventilation flues, but thin parts of walls, such as window bossings, wall presses, and other recesses, to be deducted from main walls, and classed according to thickness.

(9) All scuncheons and rybats to be charged separately by the lineal foot and classed according to their respective thicknesses and character.

(10) All arches over openings and recesses to be measured by the lineal foot at their outside or extreme lengths for extra value over common brick walling. The thickness of arch and the height of rings to be stated, and the price to include for cutting walls for arches. Skewbacks shall be enumerated 1.

(11) No allowance to be made for levelings of any kind.

(12) Cutting at angles on the various walls to be measured by the lineal foot, stating thickness.

(13) Beam fillings at wall-heads to be measured by the lineal foot, stating thickness and height.

(14) All corners of walls to be measured by the lineal foot for plumbing.

(15) Forming fireplaces (not having stone jambs and lintels) shall be enumerated, and to include for scuncheons, oncome, and arch.

(16) All vents shall be measured by the lineal foot, from the bottom of the lintel to where they finish. Oncomes of fire clay shall be enumerated.

(17) Chimney stalks shall be girthed, thickness of

brick work stated, and charged by the superficial yard, and price to include for briggs (divisions) and plumbing.

(18) Piers one brick and a half square and upwards shall be measured net by the cubic yard. The forming of corners shall be charged separately by the lineal foot.

(19) Piers under one brick and a half square shall be measured by the lineal foot according to their respective thicknesses, and to include plumbing corners.

(20) Rounded or moulded nosing bricks at rybats, corners, cornices, string or belt courses shall be measured by the lineal foot for extra value.

(21) Mitered angles, returns, and stop ends shall be enumerated for extra value.

(22) All pointing shall be measured by the superficial yard.

(23) All enameled, vitrified, or other special brick facing of walls shall be measured net by the superficial yard for extra value over common brick.

(24) Rounded, nosing, or rounded brick rybats, corners, cornices, string or belt courses to be measured by the lineal foot for extra value over special brick facing.

(25) Mitered angles, returns, and stop ends shall be enumerated for extra value.

(26) Arches shall be measured by the lineal foot for the extra value over special facing brick at their extreme lengths, stating thickness and height, and price to include cutting walls for arches. Skewbacks shall be enumerated.

(27) Vaulted and barrel arches shall be measured by

the superficial yard at the largest circumference, or outside girth, stating full thickness of rings.

(28) All cuttings at skews and groins shall be measured by the lineal foot, and charged separately for labor and waste of material.

(29) Skewbacks shall be measured by the lineal foot.

(30) Steam boiler seats and flues shall be measured by the cubic yard, and to include for all fire brick covers and resting blocks. The boilers only shall be deducted. Briggs inside of boilers shall be enumerated.

(31) Chimney stalks for furnaces shall be measured round the outside face at the start of the various thicknesses, each being stated separately, by the superficial yard, or described and taken by the lineal foot. The price in both cases shall include for plumbings.

(32) Brick paving shall be measured by the superficial yard. Cutting at angles shall be charged by the lineal foot. Forming gutter channels in brick to be measured by the lineal foot.

(33) Sewers or flues executed circular or skewed, to be measured at the extreme points.

(34) Pipe chases built or cut in walls, also raggles, for lead batting or slates, shall be measured by the lineal foot.

(35) Dooking for strapping of lined or lathed walls, to be measured by the superficial yard.

(36) Cutting batt holes, perforating walls for water, gas, and drain pipes, and executing all other jobbings required by joiners, plumbers, and gasfitters, shall be charged as a separate item.

(37) Removing rubbish connected with this department of the work to be charged as a separate item.

(38) Furnishing, lighting, and upholding lamps shall be charged as a separate item.

(39) Any mason work included under a contract for brick work shall be measured in accordance with Rules for Measurement of Mason Work.

(40) Supplying water shall be included in the prices of the work.

(41) All ordinary scaffolding, planks, tresses, and gangways shall be provided by the contractor for wright work, but these shall be set up and shifted as required by the contractor for brick work; and all gabbart scaffolding shall be provided, erected, and altered from time to time, by the contractor for wright work. But all cranes and crane seats, also all tackling and other appliances requisite for conducting the work, shall be furnished by the contractor for brick work, and shall be held to be included in the prices of the work.

(42) The foregoing rules shall be applicable to the measurement of all work, whether materials or workmanship are wholly or only partially furnished by the contractors, and likewise, when partial or sub-contracts are made for workmanship, cartage, furnishing of lime, and such like; so that the same quantities shall apply throughout the whole departments of the work.

RULES FOR MEASUREMENT OF WRIGHT WORK

(1) The general conditions (Nos. 1 to 8) shall apply to all work, unless otherwise specially provided in the following Rules.

(2) The scantlings and descriptions shall be explicitly stated, and timbers exceeding 25 feet in length shall be classed separately.

(3) All work shall be measured net, unless where allowances are specially provided for.

(4) Oblique or circular cutting on work charged net by superficial measure shall be charged by the lineal foot for waste of material and labor.

(5) Circular work shall be classed separately, and where the nature of the work requires, it shall be described as bent or wrought out of solid.

(6) All moulded returned ends, forming to circle at corners, also rounding or beveling corners of shelving, counter tops, seat boards, book boards, and other similar work, shall be enumerated.

(7) Mitres shall only be charged where stated in the Rules. All other miters shall not be chargeable separately, but shall be held to be included in the prices.

(8) All prices shall include fitting and fixing with the screws, nails, or other materials, and workmanship necessary for so doing.

(9) The charges for all temporary work, such as scaffolding, sheds, centers, and the like, shall be held to

include the adequate maintenance of the same during the currency of the work.

(10) When so specified, the wright shall furnish all scaffolding, planks and tresses required for the building. These shall be set up and shifted by the several contractors requiring them, and shall be taken down and laid on the ground by the contractor last using them. The main gangways and all supports required for the building shall be furnished and set up by the wright.

(11) Planks for supporting embankments and trenches, for wheeling, for mixing platforms, and for boxing concrete foundations shall be specified separately.

(12) The wrights shall erect uprights and fix cross needles for plasterers' scaffolds where ceilings are above 13 feet and do not exceed 20 feet in height, but the plasterer shall cover same with planks.

(13) All gabbart scaffolds and special scaffolds for carvers and other tradesmen shall be provided, erected and altered from time to time by the wright. All such scaffolding shall be classed separately, and the lengths and heights requiring gabbarts shall be stated.

(14) Shores or supports with cross-heads, at alterations or at adjoining buildings, shall be described and enumerated.

(15) The wright shall provide adequate and thoroughly water-tight sheds for hewers, tool-house and houff, and where required shall enclose the building and fit up two paths of planks with posts and handrail, and shall also fit up blinds at all openings. Should an office

for Clerk of Works be required, the wright shall erect and fit up the same as described in the estimate.

(16) When so specified, the wright shall provide templates, also moulds of wood or strong zinc for the masons' use, and lay down the requisite drawing boards, also cover stair steps and all exposed and projecting parts of mason work with rough boarding.

(17) Centers for arched openings in walls, and arches under hearths, shall be described and enumerated.

(18) Centers for barrel and groined arches shall be measured on soffit, and charged by superficial yard.

(19) Temporary boarding with bearers for concrete floors shall be measured on soffit by superficial yard.

(20) The prices for all centers and temporary boarding shall include the supports or hangers, and the cost of easing and striking.

(21) Safe lintels shall be measured by the cubic foot, and where the lengths exceed 12 feet shall be classed separately. Those in circular walls shall be measured at extremes of each piece and classed separately. When sawn all round they shall be classed separately.

(22) Taking delivery, carrying in, raising, setting, staying and racking iron pillars shall be enumerated. The heights and positions of the pillars shall be stated.

(23) Beams, sawn or dressed, shall be measured by the lineal foot, and scarves shall be enumerated. Where chamfers, beads, mouldings, or channels are required they shall be stated. Stop ends shall be enumerated. Fitch plates shall be measured by the lineal foot, and bolts shall be enumerated.

(24) Wall plates under joists and roofs, runners on and warpings in brick partitions, and warpings for linings shall be measured by the lineal foot; half checking shall be described, and included in the price.

(25) All sleeper, floor and ceiling joists shall be measured by the lineal foot, the distance from center to center being stated. The price of diagonal joists shall include cutting other joists on each side.

(26) Bridles shall be measured by the lineal foot, and the prices shall include dovetailing, morticing and tenoning as shall be described.

(27) Solid dwangs and those formed by cross pieces shall be measured by the lineal foot, measuring across joists. Iron rods through joists shall be measured by the lineal foot, and the screwed ends, nuts, heads and washers enumerated. The prices of rods shall include perforating and fitting.

(28) Framed timbers in bound couples, sawn or dressed, shall be measured by the lineal foot. In all cases the prices shall include dovetailing, morticing and tenoning. Where chamfers, beads, mouldings or channels are required they shall be stated. Stop ends shall be enumerated.

(29) Iron straps and bolts for bound couples shall be described and enumerated, and the prices for straps shall include perforating for bolts. Perforating timber for bolts, also fitting and fixing iron work of bound couples, shall be charged for each couple.

(30) Purlins shall be measured by the lineal foot, the checking at main rafters and cleats supporting purlins shall be enumerated.

(31) Common and purlin spars for roofs shall be measured by the superficial yard, the distance from center to center being stated. An allowance of 9 inches shall be made at all cuttings, and added to the quantity. Labor beveling or checking at top and bottom shall be included in the price. The deductions at dormers, roof lights, stacks, etc., shall be calculated according to the number of battons wanting. Battons of circular roofs shall be measured by the lineal foot, and the prices shall include cutting and waste of material.

(32) Ridge boards, flank and hip rafters, and wall plates shall be measured by the lineal foot. The prices for pole plates shall include checking as shall be described.

(33) Sarking shall be measured by the superficial yard. An allowance of 9 inches shall be made at all cuttings and added to the quantity, which allowance shall include supporting fillets where necessary. Doubling or tilting fillets for slates and lead shall be measured by the lineal foot. Sarking of circular roofs shall be measured net by the superficial yard without allowance, and the prices shall include cutting and waste of material.

(34) Barks, oxterpieces, and ties shall be measured by the lineal foot, the distance from center to center being stated.

Labor beveling or checking ends shall be included in the price.

(35) Platform joisting, cambered joisting, and cambered pieces on joists shall be measured by the lineal foot.

(36) Platform boarding shall be measured by the superficial yard. Bottles on edges and battens for rolls shall be measured by the lineal foot.

(37) Lined soffits of roof projections under 12 inches broad shall be measured by the lineal foot, and those at or above 12 inches broad shall be measured by the superficial yard. Mitered joints at angles of lining shall be measured by the lineal foot. Cantilevers shall be enumerated. Mouldings, facings, and skew copes shall be measured by the lineal foot, and miters on these be enumerated.

(38) Gutter boarding shall be measured by the superficial foot, each length being taken at its greatest breadth, and the price shall include cutting and bearers. Where bearers are of a greater scantling than $2\frac{1}{2}$ by 2 inches, they shall be charged separately by the lineal foot.

(39) Spars and bearers of snow staging shall be measured by the lineal foot.

(40) Framing of continuous roof lights and cupolas shall be measured by the lineal foot. Roof lights containing less than 12 superficial feet shall be measured by the superficial foot. All frames, fillets, checks, and facings shall be measured by the lineal foot.

(41) Hatch boards and service boards, with their finishings, shall be enumerated.

(42) Boarding of gangways within roofs shall be measured by the superficial yard, and bearers shall be measured by the lineal foot.

(43) Deafening-boarding shall be measured by the superficial yard, and the price shall include the fillets

supporting the boards. Joists and partitions under 9 inches thick shall not be deducted.

(44) Straps for lath on walls, scuncheons, soffits and beams, also brackering for lath ceilings, and bracketing forming or enclosing beams, shall be measured by the superficial yard, the distance from center to center being stated. Openings shall be deducted net size. Hangers lowering ceilings shall be measured by the lineal foot.

(45) The prices for straps and grounds shall include the hooks or holdfasts driven into stone or brick work.

(46) Standard partitions shall be measured by the superficial yard, the distances from center to center being stated. Openings shall be deducted net size. Runners, dwangs and cross pieces, also framing of trusses, shall be measured by the lineal foot.

(47) Ribs forming coved ceilings and domes shall be measured by the lineal foot.

(48) Bracketing for mock arches shall be measured by the lineal foot. Bracketing for cornices shall be measured by the lineal foot of cornice, the sizes of bracketing and the distances from center to center being stated. The longitudinal grounds and hooks for bracketing shall be included in the price.

(49) Blocks for gas pendants and brackets, also for bell-pulls, shall be enumerated.

(50) Lath shall be measured by the superficial yard, and partitions under 9 inches thick shall not be deducted. Lath on paneled ceilings, coves and circled work shall be classed separately. Lath at domes shall be measured net, without allowance. Lath and fillets deafening partitions shall be measured over standards.

(51) Flooring shall be measured by the superficial yard, and partitions under 9 inches thick shall not be deducted. Traversing floors shall form a separate charge by the superficial yard. Labor butting flooring, where reversed at ends, shall be measured by the lineal foot. Bearers or dwangs for flooring at borders shall be measured by the lineal foot. Cutting and fitting flooring at tile hearths and columns shall be enumerated. Hearths in floors and borders for hearths shall be enumerated.

(52) Stair steps shall be enumerated, the prices shall include treads, breasts, mouldings, brackets, and stringers or springboards. Newel posts shall be measured by the lineal foot.

(53) Bound raking and triangular lining at stairs shall be measured net and classed separately. The length of oblique rails shall be taken for cutting.

(54) Wood balusters and pedestals of stair railing shall be enumerated. Iron balusters shall be enumerated, and their price shall include thin iron strap for cope.

(55) Cope of hand rail shall be measured by the lineal foot. Scroll ends with offsets shall be enumerated, and the sizes stated.

(56) Sides and steps of trap stairs shall be measured by the lineal foot.

(57) Linings shall be measured by the superficial yard, and where grounds are required they shall be described along with the lining. Walls and ingoings shall be classed separately. Working beads or chamfers at arrises shall be measured by the lineal foot.

(58) Windows composed of sashes and cases shall be

measured 9 inches wider and 2 inches higher than the daylight size of each compartment, and charged by the superficial foot. The prices shall include pulleys, hemp cords, cast iron weights, iron screws for batten rods, fitting and hanging. If inside facings are broader than 4½ inches they shall be charged by the lineal foot for extra value.

(59) Where pulleys are of greater value than ordinary iron or brass faced ones, and the sashes are hung with materials more costly than hemp cords, these shall be specified and the windows enumerated for extra value. Lead weights shall be charged by the cwt. for extra value over cast iron. Brass screws and sockets for batten rods shall be enumerated.

(60) Windows shall be specified as with or without astragals, and as for plate, sheet or other glass, each description being classed separately.

(61) Windows having sashes divided for specially small panes shall be classed separately.

(62) Windows containing over 6 and under 12 superficial feet shall be classed separately.

(63) Moulded ends on stiles of sashes shall be enumerated.

(64) Paneled or moulded facings opposite mullions shall be measured by the lineal foot for extra value over plain facings.

(65) Framing of shop windows and side lights, also of fan lights without astragals, shall be measured by the lineal foot. Astragals in shop windows shall be measured by the lineal foot.

(66) Fixed or hinged sashes and fan lights with astragals shall be measured by the superficial foot. Frames and checks shall be measured by the lineal foot.

(67) All windows containing 6 superficial feet and under shall be enumerated, and the prices shall include frames and checks.

(68) Windows of whatever description having circled or pointed tops, also oblique and round windows, shall be measured as if square at the extreme sizes and the circled or pointed tops enumerated.

(69) In all cases the number of windows, side lights, and fan lights shall be stated.

(70) Fillets securing glass instead of putty shall be measured by the lineal foot.

(71) Where glass is charged separately, it shall be measured according to the "Mode for Glazier Work."

(72) Shutters with their closers and bound linings shall be measured by the superficial foot, soffits being taken at extreme length. Shutters having more than two panels and their corresponding bound linings shall be classed separately. Checking edges, fitting and hanging shutters and closers shall be enumerated per window. Plain linings shall be measured by the superficial yard.

(73) Facings and architraves shall be measured by the lineal foot, stating the number of pairs. Staff beads, margin-stiles, copes, moulded bases at breasts and shutter checks shall be measured by the lineal foot, base blocks shall be charged by the pair, and ragging or housing shall be specially described.

(74) Grounds with dooks for facings and architraves

shall be included with the prices for these, but dressed and checked grounds shall be charged separately by the lineal foot.

(75) Fixing ironmongery shall be charged by enumeration of windows and shutters.

(76) Frames for doors, with fixtures, shall be measured by the lineal foot, stating the number of pairs, and the prices shall include driven dooks where required. Mouldings wrought on frames shall be described therewith.

(77) Iron bolts or bats for fixing frames shall be enumerated, and the prices shall include boring, fitting and lead.

(78) Dooks built into brick walls for fixing door-frames shall be enumerated.

(79) Grounds for lining in thick walls at side opposite to doors shall be measured by lineal foot.

(80) All doors shall be charged by the superficial foot, stating the number. Doors having more than four panels shall be classed separately.

(81) Doors in two or more leaves, those prepared for glass and those containing less than 12 superficial feet, shall be charged separately.

(82) Doors having circled or pointed tops shall be measured as if square at the extreme sizes, and the circled or pointed tops enumerated.

(83) Beads covering tenons on edge of doors with their groove, also planted slips for glass, shall be measured by the lineal foot.

(84) Rounding edges of doors and hollowing frames or checks shall be measured by the lineal foot.

(85) Bars on back of plain doors shall be measured by the lineal foot.

(86) Fitting and hanging doors shall be enumerated.

(87) Facings, architraves and cheeks shall be measured by the lineal foot, stating the number of pairs. Base blocks shall be charged by the pair, and ragging or housing shall be specially described.

(88) Fixing ironmongery shall be charged by enumeration of the doors. Doors having mortise locks shall be classed separately.

(89) All bases, surbases, skirtings, beltings, copings and picture mouldings shall be measured by the lineal foot. Miters thereon, including miters to facings, shall be enumerated. Where fixtures are required for any of the foregoing they shall be described therewith. Scribing to mouldings at mantelpieces shall be enumerated.

(90) Bell boards and corner leads shall be measured by the lineal foot, and where fixtures are required they shall be described therewith.

(91) Jamb mouldings, shelves on fireplaces, mantelpieces and chimneypieces shall be enumerated. The prices shall include the necessary fixtures.

(92) Shelves, halfets and divisions 12 inches or more in breadth shall be measured by the superficial foot, but those under 12 inches in breadth shall be measured by the lineal foot.

(93) Raggles and fillets shall be measured by the lineal foot. Framed or open brackets shall be enumerated.

(94) Sparred bed bottoms with bearers shall be

enumerated. Stocks, halfets and brow bands shall be measured by the lineal foot.

(95) Framing of dressers and coal boxes shall be measured by the lineal foot. Pantry fittings shall be classed separately.

(96) Tops shall be measured by the superficial foot.

(97) Linings shall be measured by the superficial yard, and where grounds are required they shall be described therewith.

(98) Drawers shall be measured by the superficial foot, stating the number, and the prices shall include glued blocks. Those under 6 inches in depth shall be classed separately.

(99) Spars forming shelves shall be measured by the lineal foot.

(100) Slips on edges of lining, coping, fillets and sliders shall be measured by the lineal foot.

(101) Cornices shall be measured by the lineal foot, and when blocks or brackets are required they shall be described therewith. Miters shall be enumerated.

(102) Moulds for marble tops of basins, also framed supports for sinks, basins and water-closet seats shall be enumerated.

(103) Framing under washing tubs shall be measured by the lineal foot.

(104) Baths, sinks, cisterns and washing tubs, also seats, tops, and bound work of water-closets and basins, shall be measured by the superficial foot.

(105) The closet seats and basin tops shall be enumerated for the cutting and rounding of apertures. Fitting and hinging covers shall be enumerated.

(106) French polishing, when charged separately, shall be measured by the superficial foot.

(107) Pipe covers with plain grounds shall be measured by the lineal foot. Checked and beaded grounds shall be measured by the lineal foot.

(108) Tops of counters and tables shall be measured by the superficial foot. Rounding and moulding edges shall be measured by the lineal foot. Miters at mouldings shall be enumerated.

(109) Bound fronts of counters shall be measured by the superficial foot.

(110) Framing, mouldings, skirtings and toe facings shall be measured by the lineal foot. Miters at mouldings shall be enumerated.

(111) Framing of pews, also seatboards, bookboards, beaded ledges and footboards shall be measured by the lineal foot.

(112) Backs of pews and passages, also fronts of galleries and pulpits, shall be measured in detail by the lineal foot, except in the case of linings and bound work, which shall be measured by the superficial foot.

(113) Halfets shall be enumerated.

(114) Heel and head posts of trevices, also rails and spars of racks, shall be measured by the lineal foot.

(115) Trevice divisions shall be measured by the superficial foot, the full length of each board being taken, and the price shall include fitting to posts and rails. Cutting divisions to curve at top shall be measured by the lineal foot.

(116) Painting on snow staging, projections of roofs and all other outside work shall be measured by the superficial yard.

(117) Attending plumbers, gasfitters, smiths and fitters, forming screwed lifting boards in floors and linings over pipes and cranks (if brass screws and sockets are used they shall be enumerated), perforating for all pipes, gratings and cocks, also supplying and fitting bearers and blocks for gas pipes and bell wires, shall be charged as a separate item.

(118) Attending electric, heating or other engineers, shall be charged as a separate item.

(119) Cleaning out floors for painters and removing rubbish from this department of work shall be charged as a separate item.

(120) The foregoing Rules shall be applicable to the measurement of all work, whether materials and workmanship are wholly or only partially furnished by the contractor, and also to all partial or sub-contracts. Any items not expressly mentioned shall be measured and described in conformity therewith.

RULES FOR MEASUREMENT OF GLAZIER WORK

Plate Glass

(1) Plate glass, whether polished or rough, shall be measured at its extreme size; all fractional parts of inches shall be charged as full inches; irregular shaped plates shall be charged as the squares required to cut them from, and classed separately. In estimating plate glass, the size of each pane may be stated, or the contents of the panes as not above 1, 2, 3, 4, 5, 6, 7 or 8 superficial feet, above 8 to 20 feet inclusive to step 2 feet at a time, and above 20 feet to step 5 feet at a time. The words "polished plate glass" will be understood as polished on both sides; if it be polished on one side and rough on the other, to be so described and charged separately. Plates polished on one side and ground on the other, to be so described and charged separately. The thickness of the glass shall be stated, and whether it is to be of American or other manufacture. The grinding or polishing edges of plate glass shall be charged by the lineal foot, stating the thickness of the glass. Forming polished chamfers on edges of glass shall be measured by the lineal foot, stating the breadth.

Sheet Glass

(2) Sheet glass shall be measured at its extreme size, and described as best, second or third quality; all fractional parts of inches shall be charged as full inches; irregular shaped plates shall be charged as the squares

required to cut them from, and classed separately. In estimating sheet glass weighing 15, 21 or 26 ounces per superficial foot, the contents of each pane shall be stated as not above 11 feet, it being understood that no pane shall exceed in length 50 inches, or in width 36 inches; above 11 to 21 feet, the contents to be stated in steps of 2 feet, the length varying according to contents from 55 to 80 inches, and the width from 38 to 48 inches. In the case of sheet glass weighing 32, 36 or 42 ounces per superficial foot, the contents of each pane shall be stated as not above 8 feet, it being understood that no pane shall exceed in length 45 inches or in width 34 inches; above 8 to 11 feet, the steps to be stated in steps of 2 feet, the length varying according to contents from 50 to 60 inches, and the width from 36 to 40 inches; above 14 to 19, the contents to be stated in steps of one foot, the length varying according to contents from 60 to 85 inches, and the width from 40 to 47 inches; all sizes above this to be mentioned in detail for each pane, as only few sizes above 19 superficial feet are made.

(3) Crown glass shall be measured at its extreme size, and described as best, second, third, fourth, or coarse quality; if wanted more than the usual thickness, the estimate to state the particular thickness desired, fractions to be dealt with as in sheet glass. In estimating crown glass the contents of each pane shall be stated as under 2 superficial feet, and each foot thereafter up to 5 feet; above 5 feet the size of each pane to be mentioned separately.

(4) All ornamental glass (whether plate, sheet or

crown) shall be measured for glass as already described, and the ornamentation thereon particularly detailed. Colored glass when over 6 inches broad shall also be measured for glass as already described by the superficial foot, but if only 6 or under 6 inches broad by the lineal foot, stating the breadth, and if ornamented, besides being colored, such ornamentation shall be particularly detailed.

(5) Lattice work and glass shall be measured together, not by the pane, but in compartments or lights; each compartment or light shall be measured at its extreme size; and all fractional parts of inches shall be charged as full inches. Glass in tracery heads or the like shall be classed separately, and the price shall include for any moulds required.

The prices for all lattice work shall include iron stiffening rods and copper wire fixing, also pointing and painting; the diameter of rods and their distance from each other to be specially described.

(6) The glass in windows having small panes each containing under 2 superficial feet of sheet or crown glass, and separated only by astragals, shall be measured within the frames but over the astragals; any fractional parts at astragals not being allowed, but the fractions at frames dealt with as already described.

(7) The cost of cutting glass to angle or circle shall be included in the price per foot; but as already provided for, such glass shall be classed separately. All bent glass shall be classed separately, and the price shall include for any moulds required. The price of glass in all cases

shall include priming, puttying with pins, catches, and work glazing.

(8) All estimates for glazing shall contain the following entry for replacing and cleaning glass to be priced and extended by the contractor as part of the agreement: "Allow for replacing all broken glass and leaving the work clean and perfect at the completion of the building."

(9) Where painting is included with the glazing, the measure shall be the same as glazing.

RULES FOR THE MEASUREMENT OF SLATER WORK

Size, quality, and cover of slates shall be explicitly described. All quantities shall be made up from the net sizes, with the following allowances added to the quantity, and charged by the superficial yard.

Circular and upright work shall be measured net, and classed separately, with the following allowances added to the quantity:

9 inches at eaves.

18 inches at angle eaves.

1 $\frac{1}{2}$ inches at skews.

9 inches at angled skews.

18 inches at ordinary hip rafters.

27 inches at close cut hip rafters.

27 inches at hip rafters where the roll only is exposed, and the lead is under the slates.

27 inches at ordinary open or close valleys.

9 inches at angle ridges.

All voids in slating at chimney stalks and sky windows under 22 $\frac{1}{2}$ superficial feet shall not be deducted, but none of the foregoing allowances shall be added thereat. All such openings at or above that area shall be deducted net, and the usual allowances given. Joining of slates on old and new roofs shall be described and charged as a separate item.

Felt under slates shall be measured all same as slating,

including the same allowances, and the overlaps to be described.

Pointing raggles shall be measured by the lineal foot.

Pointing skews and tiftings shall be measured by the lineal foot.

Tile Work

Size, quality and gauge of tiles shall be explicitly described. All quantities shall be made up from the net sizes and charged by the superficial yard. Circular and upright work shall also be measured net and classed separately. All voids in tiles at chimney stacks and sky windows under $22\frac{1}{2}$ superficial feet shall not be deducted, but no eave tile or skew tile allowance shall be given thereon.

Eave tiles shall be described and measured by the lineal foot for full value.

Skew tiles shall be measured by the lineal foot for extra value over plain tiles.

Angled or cut tiles at hip rafters and valleys shall be measured by the lineal foot for extra value over plain tiles.

Hip tiles, valley tiles and ridge tiles shall be measured by the lineal foot for full value.

Tile finials shall be described and enumerated.

Making templates for all tile work shall be charged a separate item.

Felt under tiles shall be measured all same as tiles without any allowances, and overlaps to be described.

Chimney pots shall be described and enumerated.

Repairing slates or tiles after all other tradesmen are

finished, cleaning out gutters and removing rubbish, shall be charged a separate item.

Upholding roofs shall be described and charged a separate item.

Rough casting shall be measured net by the superficial yard.

Arrises at corners and ingoings to openings, etc., shall be measured by the lineal foot for extra labor.

Cleaning of dressings shall be described and charged separately.

Lime and cement washing shall be measured all as described for rough casting.

The foregoing rules shall be applicable to the measurement of all work, whether materials and workmanship are wholly or only partially furnished by the contractor, and also to all partial or sub-contracts. Any items not mentioned shall be measured and described in conformity therewith.

RULES FOR THE MEASUREMENT OF PLUMBER WORK

Sheet lead to be measured and calculated so as to bring out the net weight, and charged per hundred-weight, according to the following classification:

- I. Platforms with rolls.
- II. Gutters.
- III. Valleys, ridges and hip rafters.
- IV. Aprons, flashings and flanges.
- V. Aprons stepped as for brick work.
- VI. Drip boxes.
- VII. Domes, turrets, belfries and such like.

Extra labor working lead to wood mouldings to be charged separately.

Soldering pipes to flanges to be described and enumerated.

Zinc on roofs to be specified by weight, charged by the superficial foot, and classed similarly to lead.

All soldered joints of zinc to be charged by the lineal foot.

Zinc rolls to be described, stating girth and charged by the lineal foot. Ends and intersections to be described and enumerated, and charged for extra material and labor.

All iron eave gutters to be measured net and charged by the lineal foot, the slips and clips to be added to the length.

Angles, ends and outlets to be described and charged separately.

The prices of all iron rones, gutters and connections to include for all labor and materials in bolting, jointing and fixing.

Cast iron pipes to be charged by the lineal foot, slips being added to the length; where airtight or watertight joints are required, these to be described.

All connections, such as cistern heads, offsets, bends, shoes, and branches to be described and charged separately.

Pipe ears, whether cast on or loose, to be described and charged separately, and price to include fixtures.

All special castings to be particularly described or shown by sketch.

Malleable iron pipes to be described as for steam, water or gas, and charged by the lineal foot, the price to include for screwed ends and straight couplings.

All other connections and bends to be enumerated and charged separately.

Lead pipes to be described and charged by the lineal foot.

Bends on pipes over one and a half inch bore to be enumerated and charged for extra labor.

Wiped solder joints of branches to be enumerated and charged for extra material and labor.

Soldered stop ends of pipes to be enumerated.

Cast or sheet lead wings where required, to be described and charged extra over holdfasts.

Copper pipes to be described and charged by the lineal foot.

Bends on pipes to be enumerated and charged for extra labor.

All brass connections to be enumerated and distinctly described as with or without couplings.

The prices of all pipes and connections to include for bolthasts and fitting up.

Sheet lead lining cisterns and baths to be charged per hundredweight, and where not otherwise described, these to be understood to have wiped, soldered or burned joints.

Zinc lining cisterns to be described and charged per superficial foot, and price to include soldered joints.

Iron, copper, plate zinc, or other cisterns for water-closets and such like, to be described and enumerated.

Supply, overflow, and discharge fittings to be described and enumerated.

Water-closets with connections and fittings to be fully described and enumerated.

Safes to be described and charged separately, weight and sizes to be stated.

Baths, wash-hand basins, foot pails, sitz baths, sinks, and wash tubs to be described, and sizes to state whether outside or inside measure.

All fittings to be separately detailed.

All measurements shall be net, and the sizes stated for pipes and cocks shall be inside diameter.

The prices shall be held to include for all materials, tools, plant, carriage, and every other expense requisite for preparing, making, fitting and fixing on the job, and, where required, for giving the necessary notices to the local authority for having the water laid on, and attendance upon the officials thereat.

An item to be inserted in schedule for attending sanitary authorities while testing soil and other pipes, and making good all defects to their entire satisfaction.

The foregoing rules shall be applicable to the measurement of all work, whether materials and workmanship are wholly or only partially furnished by the contractor, and also to all partial or sub-contracts. Any items not expressly mentioned shall be measured and described in conformity therewith.

RULES FOR THE MEASUREMENT OF PLASTER WORK

Deafening

Plaster, ashes or composition forming leafening between joists, also plaster deafening standard partitions, shall be measured by the superficial yard on the net area of floor or partitions deafened.

Plaster

Every description of plaster and cement work shall be measured net on the finished surface, without the addition of any allowance whatever. Circular, ovoid, groined and domed work, also rounded plaster on backs of steps and plaster work at repairs, shall be described and classed separately. The measurement of plain plaster shall include the surface behind all mouldings, and behind plaster, cement or wood skirtings; though these surfaces have not received a finishing coat. The measurement of plain cement shall include the surfaces behind cement mouldings and skirtings, but not those behind wood skirtings.

The cost of cutting out and preparing old plaster for junction with new work shall be included in the price for new plaster at repairs without allowance.

Patches under two superficial yards shall not be included with larger patches, but shall be classed separately, or charged at jobbing rates where they do not form the subject of a special agreement.

All work shall be measured by the superficial yard, with the exception of diaper work, Keene's cement, and cement hearths, which shall be measured by the superficial foot.

All mouldings shall be measured by the lineal foot at the extreme length of each stretch, thus adding all projections.

Impost cornices, cornices run at obtuse angles, such as along camp ceilings, and all mouldings to match old work, shall be described and classed separately.

Astragal and architrave mouldings, whether run along with cornice or not, shall be charged separately.

All external, internal, obtuse or acute miters on mouldings, butt and splayed ends, also joinings with old mouldings, shall be enumerated and charged separately. The breadth and depth of all mouldings shall be stated.

Friezes, bands and rails shall be described as plain, raised, arrised, or moulded, and charged by the lineal foot. Miters on arrised or moulded work shall be enumerated separately.

Paneled soffits of beams may be measured in detail, or described and charged by the lineal foot of beam.

Enrichments in mouldings shall be described and measured by the lineal foot at their net lengths, irrespective of the length of the moulding in which they occur. The miters shall be enumerated separately.

Enrichments to match old work shall be classed separately.

Capitals, center flowers, corner, and other ornaments shall be described and enumerated.

Unless otherwise provided, all ornaments to be selected from plasterer's stock.

A sum shall be charged for each ornament specially modelled, irrespective of the quantity used. On the payment of any model it shall belong to the proprietor, and must not be again used without his architect's consent.

Bases and skirtings shall be described and charged by the lineal foot. All external and internal angles shall be enumerated separately. Cement pugging behind wood skirtings shall be described and charged by the lineal foot, and if extra over plaster the same shall be stated.

No charge shall be made for internal angles at any description of plain work, except for diagonals at camp ceilings which shall be charged by the lineal foot.

External angles shall be measured by the lineal foot, describing whether they are relieved timber beads, rounded corners, plain arrises, splays, beads, or mouldings and whether wrought in plaster or cement work.

Miters and stops at plaster beads, splays, and mouldings shall be charged separately.

Columns, pillars and pilasters shall be measured between base and capital, fillets at bottom or top being part of shaft.

They shall either be described and charged by number, or be measured by the superficial foot; fillets, arrises, and flutes being charged separately.

The bedding and pointing of windows shall be charged per window, those having mullions or transoms being classed separately.

Mending all damaged or broken plaster at new work.

except repairs caused by alterations, also removing rubbish and furnishing all moulds required, shall be provided for in schedules as a special slump sum item, and shall not be charged at jobbing rates.

All scaffolding shall be provided by the contractor for wright work; but the contractor for plaster work shall without charge set up and shift ordinary scaffolding planks, tresses, etc.

The prices for all work shall be held to include supplying materials, water, tools, rods, and labor necessary for its completion.

The foregoing rules shall be applicable to the measurement of all work, whether materials and workmanship are wholly or partially furnished by the contractor, and also to all partial or subcontracts. Any items not expressly mentioned shall be measured and described in conformity therewith.

RULES FOR MEASUREMENT OF PAINTER WORK

In all cases the work shall be explicitly described, giving, where required, the sizes, girth or breadth, also stating the number of coats and whether finished plain or in shades, in oil, flat or varnish. When in more than two shades the number shall be stated.

Imitations shall have the number of coats of ground and varnish stated.

Fine colors and extra kinds of varnish shall be specially mentioned.

All quantities shall be made up from the net sizes, the extra measurement for circulars, beads and mouldings of woodwork being added where they occur.

All glass in panes exceeding 18 inches wide and 4½ feet superficial shall be deducted, less an allowance of 1½ inches for cutting round same.

An allowance of 1½ inches for cutting shall be given to the more expensive work at joining of different kinds of painter work where both are charged by superficial measurement, as also to painter work at joining with existing paper hangings.

The plain surface of ceilings shall be measured net, and charged by superficial yard.

Cornices shall be charged by lineal foot, stating girth and number of shades and describing enrichments.

Picking in, illuminating and gilding enrichments in

cornices shall be charged separately by lineal foot, but space ornaments may be enumerated.

In making out estimates, the gold for hatching enrichments may be charged by the book.

Colored and gold lines shall be charged by lineal foot.

Beams, ribs and panel mouldings on ceilings shall be charged by lineal foot as described for cornices.

Friezes and astragal mouldings on ceilings will generally be included in girth of cornices, but on walls they shall be kept separate, and charged by lineal foot, as described for cornices. Center flowers and detached ceiling ornaments shall be enumerated.

Picking in, illuminating and gilding shall be charged separately.

The plain surfaces of walls shall be charged by the superficial yard.

Woodwork generally, whether bound or plain, shall be charged by the superficial yard. Panels or other mouldings in special colors shall be charged by the lineal foot.

Bases, surbases, beltings, etc., when detached or painted differently from the adjoining works, shall be charged by lineal foot.

Sashes in extra small panes shall be charged separately by the superficial yard.

Timbers of roof couples shall be charged separately by the superficial yard.

Mantel-pieces shall be enumerated.

Colored bands under 24 inches broad, forming friezes, dados, stiles of panels, or grounds for decorations, shall be charged separately by the lineal foot.

Colored or gold lines, imitation mouldings formed of lines, and running decorative ornaments, shall be charged by the lineal foot. Detached decorative ornaments shall be enumerated.

Circled bands and decorations, also bands and decorations on circled groundwork, shall be charged separately.

Circled corners or miters on imitation mouldings shall be enumerated.

Decorative work on panels, etc., may be enumerated or charged by superficial foot.

Lines for imitation ashlar, marble slabs, or planked woodwork shall be described with and included in price for same.

The prices of all lines and decorative work shall include striking out.

Iron railings shall be described as plain or ornamental, and measured on both sides by the superficial yard.

Intermediate dwarf balusters shall be measured extra on both sides.

Rods and pipes shall be charged by lineal foot.

Bolt heads, washers, brackets, hinges, locks and similar items shall be enumerated. Iron beams and similar work above 18 inches in girth shall be charged by superficial yard, and up to 18 inches in girth by the lineal foot.

Iron columns shall be described and enumerated.

Papers, also sizing for and hanging same, shall be described separately, and charged by the piece, but in making out estimates sizing and hanging may be charged by the net superficial yard.

Paper friezes, dados and borders, also hanging same, shall be charged by lineal yard.

Canvas and scrim cloth shall be charged by superficial yard, including tacks and putting on.

All miters shall be enumerated.

Imitation marbles shall be charged by superficial foot.

Columns and pilasters may be described and enumerated.

Outside work shall be kept separate, and described to show where ladders are likely to be required.

Windows shall be enumerated.

Special designs for decorative work ordered by the proprietor or architect, and prepared by the painter, shall be made a separate charge.

Puttying and preparing new work before painting shall not be charged, unless by special agreement made before the work is begun. Washing, polishing, puttying, scraping or burning off old paints, stripping papers and other similar work, shall be made a separate charge, including time and materials.

Time and use of materials where required for covering floors, chimney-pieces, etc., to protect them from paint spots during operations, shall be an extra charge.

Washing floors when ordered before commencing or after finishing work shall be an extra charge.

Carriage of materials to country jobs shall be included in prices.

Allowance for country wages shall be included in prices.

The prices shall include for supplying all ordinary

plant, but special or gabbert scaffolds shall be an extra charge.

A charge for overtime shall be allowed when contract work is ordered by the proprietor or architect to be done before or after the usual working hours.

The foregoing rules shall be applicable to the measurement of all work, whether materials and workmanship are wholly or only partially furnished by the contractor, and also to all partial or sub-contracts. Any items not expressly mentioned shall be measured and described in conformity therewith.

METHODS OF MEASURING

In the former part the rules for measuring the different kinds of artificers' work have been given, and now we have to consider the method of carrying them out in practice. In doing so we may state that we do not intend to touch upon the quality of materials, nor of the component parts which are comprised in their manufacture, but solely to adhere to the elucidation of the method employed in measuring the various departments of work. A vast amount of valuable information of great assistance to the estimator can be had from "The Estimator's Handbook and Guide" by Mr. Fred T. Hodgson, which would be of service in pricing the various items.

In taking off the quantities from the plans, the same method should be carried out, as described for measuring completed work, but it is very essential that the estimators should have a thorough knowledge of building construction and be able to describe minutely and explicitly every item, so that there may not be any ambiguity as to the meaning of same.

The instruments commonly used in measuring the various works are, a 6-foot rod, a 3-foot rule, and a 50-foot or 60-foot tape line. It is necessary also to have a book to mark down the measurements—preferably one of an oblong shape, and lined off thus, so that it may be easily held in the hand:

FORM OF DIMENSION BOOK

DIMENSIONS		
2-0	Rubble front wall.....	47-0×30-0
	Rubble projection of cornice	4½×47-0×1-0
	Rubble projection of string course.....	2½×47-0×0-6
	Ded. 6 wns.....each	4-0×8-0
	1 door.....	3-6×6-0

METHOD OF MEASURING MASON WORK

(1) Foundations are measured thus:

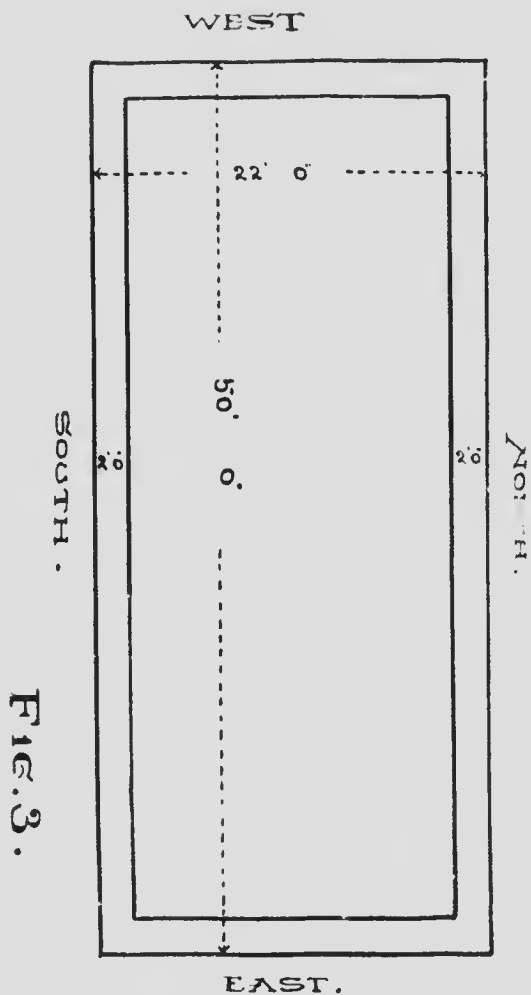

FIG. 3.

2'0" rubble foundation for south or front wall . . . 50-0 × 1-0 = 5-5-0

2'0" rubble foundation for north or back wall . . . 50-0 × 1-0 = 5-5-0

2'0" rubble foundation for east gable.....18-0×1-0= 2-0-0
 2'0" rubble foundation for west gable.....18-0×1-0= 2-0-0
 Superficial yards 15-1-0

Foundations of cube stones measured thus:

Cube stone in foundation of walls.....36-0×1-0×1-0=36-0

(2) In measuring rubble work the full thickness of wall is taken including the face work. The exceptions you will find in rule No. 2 of the mason work. The following is an example how to measure a stone wall 2'0" thick:

2'0" rubble building of front wall.....67-0×12-0
 2'0" rubble building of projection of moulded
 course4"×67-0×0-6
 2'0" rubble building of projection of plinth...3"×67-0×0-6
 Deduct 1 door.....4-0×7-0
 2 windows.....each, 3-6×6-6
 2 windows.....each, 3-6×5-6
 Superficial yards

The rules Nos. 3 to 8 inclusive require no elucidation.

(9) Principal stones are measured thus:

1 principal stone.....2-10×1-6×1-0=4-3
 1 principal stone.....3-0×1-8×1-0=5-0
 Cubic feet 9-3

Stones more than 24 inches in breadth and the breadth of which exceeds twice the thickness, shall be measured by the superficial foot and classed according to their thickness and contents, thus:

12" stone in arch over door..... 2-0×2-2=superficial feet 4-4

Stones other than these two classes, and above 14 inches by 9 inches, shall be measured by the lineal foot, and classed according to breadth and thickness, and according to length where it exceeds 4 feet, thus:

15×10 stones in 4'6" lengths..... 3 each, 4-6=lineal feet 13-6

FIG. 4.

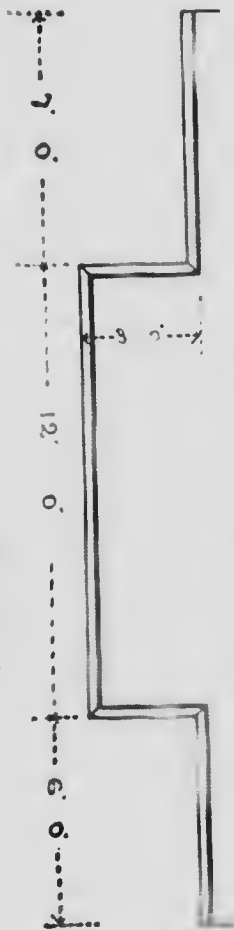

(10) Polished hewing of principal stones in arch over floor.

10-0 x 2-6 superficial feet 25-0

Measure return for moulded work thus at extremes.

Moulded belt course 31-0

Forming 4 mitres on belt course.

Forming 2 moulded ends.

(11) 14 x 9 stones over doorway in 4' 6" lengths, girth of hewing 30 inches. 2 each, 4-6=9-0

(18) Chimney stacks to be girted thus:

Quantity of chimney
 stack 16-0 x
 Dressed brick 6-0
 18" polished moulded course in 3' 0" length
 of hewing 30" 2 each 4-0

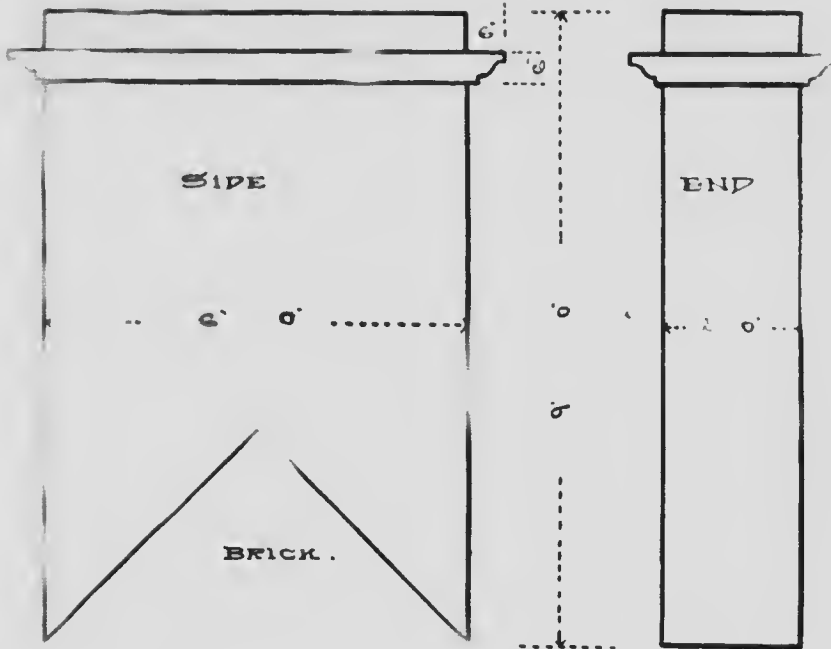

FIG. 5

(22) Polished ashlar newel measured thus:

6 Ashlar newel	1	= superficial feet	120-0
Polished hewing on ashlar newel, 2-		= superficial feet	<u>250-0</u>

(23) Pavement to be measured thus:

Cutting at angle		7-0 x 3-0 =	<u>21-0</u>
		lineal feet	<u>6-0</u>

ORDER OF ARRANGEMENT

NOTE.- Copy estimates in following order, viz.:

The excavator, mason, brick, iron and steel works,
see page 64.

The carpenter and joiner works, page 122.

Slater work, see page 100.

Lather and plaster works, page 101.

- Plumber work, page 103.
 Tile linings, page 106.
 Painter work, page 107.
 Methods of measuring, page 58.
 Method of measuring mason work, page 60.
 Method of measuring brick work, page 77.
 Method of measuring carpenter and joiner work,
 page 82.
 Method of measuring glazier work, page 93.
 Method of measuring slater work, page 95.
 Method of measuring plaster work, page 97.
 Method of measuring plumber work, page 103.
 Method of measuring painter work, page 107.
 Form of measurement for mason and brick works,
 etc., page 110.
 Form of measurement for plaster work, page 131.
 Form of measurement for plumber work, page 139.
 Form of measurement for tile lining, page 142.
 Form of measurement for painter work, page 143.
 Notes on various works, page 147.
 Forms in note book, page 168.
 The following is an example of making out an esti-
 mate for the excavator, mason, brick, iron and steel
 works of tenements and shops.

Excavations and Foundations

Excavating earth in area and trenches for foundations, the stuff to be carted away, cubic yards.....	1,400-0-0
Foundations under outer walls and gables, of concrete, composed of four parts granite broken to pass through a 1½-inch mesh,	

to one part sharp sand and one part best fresh Portland cement cubic yards	<u>144-0-0</u>
Brick work in foundations, thoroughly well packed and grouted with thin lime mortar, cubic yards	<u>40-0-0</u>
Hammer dressed stone foundations of iron pillars, 3'0" square and 14" thick, bedded in lime mortar cubic feet	<u>94-6</u>
Hammer dressed stone foundations of iron columns, average 3'-0"-2'-0" and 14" thick, bedded in lime mortar cubic feet	<u>42-0</u>
Droved hewing on top of foundations, sq. feet	<u>117-0</u>
Bedded sole-plates of 9 iron pillars in pure Portland cement grout.	
Rubble seats under 6 hearths, each about 2'0" high.	
Building temporary office for clerk of works, having 9" brick walls 10'0" square inside, chimney stack, fireplace and grate, and supplying coals complete.	

Walls to Level of Surface

NOTE.—The walls are measured net for rubble work, the daylight size of openings, also thin parts of walls (except at vents) deducted, the hewn work and cube stones charged separately for extra value unless where mentioned to include building.

2'0" Rubble walls of large size material, built in regular and level courses with Portland cement, having through bond headers in every course not more than 5' apart square yards	<u>72-0-0</u>
1'10" Rubble wall north gable of large size material, built in regular and level courses with Portland cement, hav- ing through bond headers in every course not more than 5' apart square yards	<u>5-0-0</u>
Hammer dressed out and inbond corners of back wall in stones 24" long and 12" thick on head lineal feet	<u>5-0</u>
1¼" Freestone pavement damp course, all sawn on joints and laid in breadths, the full thickness of walls on bed of Portland cement mortar including leveling walls, square yards	<u>146-0-0</u>
1¼" Freestone pavement damp course, on dwarf partitions 9" broad lineal feet	<u>234-0</u>

Piers of Shop Front

Cube stone piers, well dressed on beds and joints, including building	cubic feet	266-0
Striped hewing on sides	square feet	168-0
Checked hewing on sides	square feet	18-0
Polished plain hewing	square feet	120-0
Labor working polished splays 3" broad on bases	lineal ft	10-0
Extra for 8 miters on splays
Extra for moulding under trusses at top of shafts, including extra size of stone and hewing	lineal feet	8-0
Labor working 8 polished moulded and fluted trusses, as per drawings
Labor raising and setting 6 cast iron double columns, each about 12 feet high, of shop front
Labor raising and setting 9 circular pillars, each 12 feet high, with sole and top plates
Labor raising and laying cast iron L and J beams	lin. ft.	117-0
Labor raising and laying cast iron box-beams, lin. ft.	27-0

Rubble Walls above Surface Level

2'0" rubble front wall	superficial yards	210-0-0
2'0" rubble back wall	superficial yards	230-0-0
1'10" rubble north gable above brickwork, superficial yds	156-0-0
1'6" rubble return wall at	superficial yards	9-4-6
1'3" rubble pediments on front wall	superficial yards	12-0-0
1'0" rubble walls of oriels and at window bossings and wall presses	superficial yards	203-0-0
Extra for hammer dressed squared rubble forming beveled frieze over shop front	superficial yards	21-0-0
Hammer dressed scuntions of window bossings in 2'0" and 1'10" walls	lineal feet	275-0
Hammer dressed scuntions of window bossings in 1'6" walls	lineal feet	6-0
Hammer dressed openings at oriels	lineal feet	360-0
Hammer dressed square scuntions of wall presses in 1'10" gable	lineal feet	42-0
Labor tying end of 1'6" wall into 18" brick wall, lineal feet	16-0

Wall Dressings

Cube stone cornice over shop front in stones 36" broad and 12" thick, well dressed on beds and joints, cubic ft.	336-0
Polished plain hewing on beds and joints, superficial feet	168-0

Polished moulded hewing on beds and joints, superficial ft.	178.0
Labor mitering and returning upper and lower members of cornice at top of 4 stone piers	_____
16" x 8" polished plain sill course above cornice, girding 17", lineal feet.....	48.0
16" x 15" polished plain sill course serving as window sills, girding 31" in stones 63" long	lineal feet 19.0
Extra material and labor forming 4 semi-circled and moulded pediments each 33" x 12" on face over trusses	_____
Labor perforating cube stone for conductors .. lineal feet	52.0
10" x 6" polished moulded sill course, girding 14", lineal ft.	58.0
18" x 6" polished moulded sill course, serving as window sills, girding 23"	lineal feet 18.0
Labor perforating, mitering and returning sill course at 4 conductors	_____
Extra for 2 circled pieces moulded sill course, including miters as per drawing	_____
1 polished moulded stones, 20" x 15" on face, and pro- jected 6", perforated, mitered and returned round con- ductors	_____
Hammer dressed stone cornice at wall head 10" thick and 33" broad, including building.....	superficial feet 77.0
Hammer dressed stone cornice at wall head 10" thick 21" broad, including building.....	superficial feet 174.0
Polished moulded hewing on same.....	superficial feet 286.0
2 plain stop ends	_____
40 miters of moulded cornice	_____
6 polished projecting stones at ends of cornice at sides of pediments, having peened face, including material, hewing and building as per drawing	_____
Labor cutting gutter in cornice.....	lineal feet 127.0
Labor perforating 4 drip holes in 10" cornice, 4 each ...	_____
Dabbed courses of front wall and north gable, 6" on bed and two courses in height of each rybat, having 12" droved margin round each stone, with the necessary headers.....	superficial feet 2250.0
Dabbed out and inband corners in stones not less than 24" long and 12" thick on head, with droved margins, girth of hewing 36"	lineal feet 62.0

Dressings of Windows

Droved out and inband back filleted rybats, in stones not less than 24" long, 12" thick on head and 13" high, having neatly dabbled tails and bead moulding on arris, girding in all 32", the price to include for hammer dressed beveled inside scuntionslineal feet	120-0
13"×10" droved out and inband back filleted lintels, with neatly dabbled tails and bead moulding on arris, in single stones, from 6'0" to 6'9" longlineal feet	39-0
13"×10" droved out and inband back filleted lintels, with frieze and astragal 18" deep in alllineal feet	18-0
Labor working 18 returns of moulded lintels for rybats	
Labor working 9 returns for double moulded mullions	
Labor working 12 polished plain ends of back filleted lintels, each projecting one inch	
Labor working 6 polished moulded and mitered lintels	
16"×7" polished moulded sills in stones about 6'6" long lineal feet	15-6
Labor working 6 polished, moulded and mitered return ends of sills	
7"×6" polished mullions hewn all round and having bead moulding on both arrises in stones from 6'3" to 6'9" long, including buildinglineal feet	60-0
3 polished moulded cornices each 6'9" long and 8" thick, projecting 6 inches in one stone, returned both ends	
3 polished moulded cornices each 6'9" long, and 6" thick, projecting 6 inches in one stone, returned both ends	
3 polished moulded and scrolled coronas, each 6'0"×3'0" on face, and 10" on bed, in one stone and having moulded and pyramidal ornament in center as per drawing	
Carving in 12" letters "1895" on one stone, including extra size of stone	

Oriel Windows

16"×15" polished plain sill course, girding 31", lineal feet	66-0
18"×6" polished moulded sill course, girding 28", lineal ft.	180-0
48 miters of sill course	
Labor checking sill course for iron I beams, and grouting with Portland cementlineal feet	66-0
Polished moulded cornices, girding 20"lineal feet	102-0

24 mitres on cornices	_____
13"×12" polished moulded lintels, girding 24" ..lineal feet	198-0
Labor working 72 returns of moulded lintels for rybats and mullions	_____
12" polished ashlar dados.....square feet	336-0
Polished out and inband projected jambs in stones 30"×12" and 20"×15" alternately, with bead moulding on arris, girding in all 30"	lineal feet 237-0
12"×12" polished angular mullions in stones from 6'3" to 6'9" long, girding 31", with bead moulding on both arrisies	lineal feet 237-0

Dressings of Back Wall, North Gable and Return

Extra for outside of back wall, etc., being of fairly squared work—no stones less than 3" high and all stones at least twice their height in length, fairly dressed where exposed, with level beds and plumb joints, trowel pointed while being built, and the joints to be afterwards raked out at least one inch deep, pointed with Arden lime and key drawn—openings and dressings deducted.

N. B.—The pointing to be done at such time as the en- gineer may appoint and the price to include for scaffolding.....	superficial yards 350-0-0
Out and inband corners in 2'0" and 1'10" walls, having 2½" droved margins and neatly hammer dressed tails, the stones not less than 20"×10".....	lineal feet, 82-0
Out and inband corners in 1'6" wall, having 2½" droved margins and neatly hammer dressed tails, the stones not less than 20"×10"	lineal feet, 14-0
16"×6" droved projected plinth at back wall head, lineal ft.	54-0
Droved out and inband rybats in stones not less than 20"×10", with 2½" margins and neatly hammer dressed tails, price to include for hammer dressed beveled inside scuncheons in 1'10" and 2'0" walls....	lineal feet 318-0
Droved out and inband rybats in stones not less than 20"×10", with 2½" margins and neatly hammer dressed tails, price to include for hammer dressed beveled in- side scuncheons in 1'6" wall.....	lineal feet 8-0
13"×10" droved checked lintels with 2½" margins and neatly dressed tails	lineal feet 123-0
14"×6½" droved projecting window sills, girding 22", lineal feet.....	126-0

Brick Work

18" brick gables with vents formed in brickwork (measured separately).....	square yards	850-0-0
22" brick north gable up to level of stone.....	square yards	60-0-0
14" brick back wall at staircases.....	square yards	280-0-0
9" brick walls of back wings, built with Portland cement.....	square yard	380-0-0
9" brick dwarf walls under sleepers.....	square yards	40-0-0
4 1/2" brick partitions.....	square yards	2170-0-0
Plumbing plain scuncheons 14" broad.....	lineal feet	820-0
Plumbing plain scuncheons 4 1/2" broad.....	lineal feet	440-0
Forming 36 openings for ventilation in 4 1/2" partitions at ends of beds as per plan.....		—
Forming checks and plumbing scuncheons in 9" walls, lineal feet.....		618-0
Plumbing angles of walls.....	lineal feet	280-0
Labor cutting 18" gable tops at angle, including for loss of material.....	lineal feet	84-0
Labor cutting 14" gable tops at angle, including for loss of material.....	lineal feet	30-0
Labor cutting 9" gable tops at angle, including for loss of material.....	lineal feet	21-0
Extra for rounded brick at angles.....	lineal feet	1132-0
Vents in brick gables, smoothly plastered with haired lime.....	lineal feet	1420-0
9" brick building walls of ash pit, pointed with arden line and key drawn on outside and flush pointed inside.....	superficial yards	21-0-0
Cutting brick at skews.....	lineal feet	12-0
Plumbing plain scuncheons 9" broad.....	lineal feet	11-0
Plumbing external angles.....	lineal feet	26-0
Slate slab breast of ash pit, including building, super. ft.		9-0

Dressings of Brick Walls

Facing wall of back wings with selected white facing brick having headers, neatly pointed with Portland cement and key drawn in joints on outside (for extra value over common brick).....	superficial yards	356-0-0
Extra for forming semi-circular arch tops of 3 openings each 3'0" span daylight in 9" brick walls...		—

11"×6" polished plain projected plinth on wall heads (including laying)	lineal feet	60-0
Polished plain hewing on C ends of plinth		
11"×6" polished projected sills to windows	lineal feet	35-0
11"×6" polished projected sills to windows hewn on inner edge	lineal feet	135-0
12"×9" polished checked lintels	lineal feet	33-0
12"×9" polished checked lintels, hewn on inner edge, lineal feet		138-0
12"×9" polished checked semi-circled arched lintels, lineal feet		53-0

Chimney Stacks, Skews, etc.

Polished ashlar chimney stacks on gables (price to include building) girded	superficial feet	1780-0
4½" brick brigs	lineal feet	423-0
Labor working splay on ashlar	lineal feet	108-0
Labor working astragal moulding on ashlar, including for extra size of stone	lineal feet	163-0
Labor working 28 miters of same		
10"×6" polished moulded plinth, girding 12", including laying	lineal feet	202-0
28 miters of plinth		
24"×10" polished, moulded stone copes as per plan, dressed well on beds and joints, including hewing and building	lineal feet	78-0
Polished, moulded and mitered hewing 14 return ends of stone copes		
Labor cutting vents through copes and socketing copes for 53 chimney pots		
12"×6" polished, moulded and beveled label moulding, girding 14", including laying	lineal feet	54-0
12"×6" polished, moulded and beveled circular label moulding	lineal feet	8-0
1 polished projecting stone panel 7'0" broad and 8'6" high on extremes, the center part left rough for carver and having circled upper part, including cut- ting for and inserting panel into bottom of chimney stack, per drawing		
Carving on same as per drawing		

9 polished and moulded stone trusses under panel and bottom of chimney stalk, including building, as per drawing.....	_____
8 polished and moulded steps with polished breasts on north gable, as per drawing.....	_____
2 polished and moulded terminals to north gable, as per drawing.....	_____
21 dabbled crow steps, average 15"×12" and 21" long, having 1/2" droved margin all around, built with Portland cement (including building) as per drawing....	_____
3 dabbled crow steps, average 15"×12" and 33" long, having 1/2" droved margin all around, built with Portland cement (including building) as per drawing.....	_____
6 dabbled corbels each 15"×12" and 30" long, with moulded ends and plain sides (including building), as per drawing.....	_____
3 polished ornamental finials each 12" square at base and 39" high in all, with iron dowel and cement, including building, as per drawing.....	_____
12"×6" polished plain skews on main gables (including laying)	lineal feet 84-0
9"×6" polished plain skews on side walls of wings (including laying)	lineal feet 27-0
6 polished club skews on main gables, having moulded outline on face (including laying)	_____
6 polished club skews on side walls of wings (including laying).....	_____
Extra for 9"×6" stone skews of wings, being kneed on top and hollowed on under side, as per drawing, 6 each	_____

Chimney Jambs, Vents and Hearths

18 sets hammer dressed covins and lintels for room fireplaces in brick gables, including oncomes	_____
33 pair polished kitchen chimney jambs each 18"×6" and 4'0" long.....	_____
33 polished lintels each 12"×10" and 4' long, hewn on both ends, and having hammer dressed oncomes....	_____
4 1/2' Brick trimmer arches under room hearths, built with Portland cement.....	18 each _____
4 1/2' Brick trimmer arches under kitchen hearths, built with Portland cement.....	27 each _____

9" fire clay vent linings, grouted all round with lime mortar, in stone wall.....lineal feet	90-0
2½" polished stone hearths of the best quality, laid on a good bed of limesuperficial feet	<u>490-0</u>

Stairs and Pavement

3" polished stone platts in shop doors, laid in lime, superficial feet.....	48-0
Labor working polished chamfered edge of platts.....	
..... lineal feet	24-0
24 polished, moulded stone steps of stairs each 4'0" long, clear of 2 rests.....	_____
12 polished winding steps of stairs from 4'0" to 5'10" long, clear of 2 rests.....	_____
108 polished, moulded stone steps each 4'0" long, clear of 2 rests (rounded on back).....	_____
27 polished moulded stone steps each 4'6" long, clear of 1 rest, returned on 1 end (rounded on back).....	_____
Brick building under 3 first steps of stairs (if required) 3 each.....	_____
15 polished, moulded corbels each 18"×8"×6" under beams.....	_____
10" polished perpend dados of shop windows and side-lights, including building, in stones from 3'0" to 6'0" long and 1'0" deep.....superficial feet	108-0
Labor cutting polished perpend dados to slope of ground, lineal feet.....	72-0
Labor cutting and forming miters at 12 angles.....	_____
Single coat unfinished asphalt paving having 4" bottoming of freestone shivers, well beat down, under wood floors.....superficial yards	390-0 0
12"×8" new dressed freestone border, laid on flat, including laying.....lineal feet	160-0
Paving front footpath and back courts with concrete 5" thick, composed of four parts new, clean, hard burned brick, broken to pass through a 1½" ring, one part clean, sharp gravel sand, and one part fresh Portland cement (all by measure) thoroughly mixed by being turned over twice before and twice after being watered with a water hose, and finished with granitic 1½" thick, in the proportion of equal parts	

of crushed, sifted, and finely ground granite and Portland cement, rolled with roller.....superficial yards	560-0-0
Paving water closets, lavatories and sculleries, also stair landings, closets, etc., with concrete 5" thick, composed of four parts new, clean, hard burned brick, broken to pass through a 1½" ring, one part clean, sharp gravel sand, and one part fresh Portland cement (all by measure) thoroughly mixed by being turned over twice before and twice after being watered with a water hose, and finished with granitic 1½" thick in the proportion of equal parts of crushed, sifted, and finely ground granite and Portland cement, rolled with roller.....superficial yards	230-0-0
Paving with concrete 4" thick on roof of ash pits, composed of four parts new, clean, hard burned brick, broken to pass through a 1½" ring, one part clean, sharp gravel sand, and one part fresh Portland cement (all by measure) thoroughly mixed by being turned over twice before and twice after being watered with a water hose, and finished with granitic 1½" thick, in the proportion of equal parts of crushed, sifted, and finely ground granite and Portland cement, rolled with roller, including forming edges.....superficial yards	7-0-0
Labor forming gutters in paving.....lineal feet	236-0
Labor forming 6 basins in paving.....	153-0
Labor forming moulded edges of stair landings, lineal feet	12-0-0
2" second class freestone pavement, sawn on edges and jointed with Portland cement, covering drains, superficial yards.....	550-0
Cutting raggles 4½"×1" in brick walls for concrete paving.....lineal feet	

Iron and Steel Works

NOTE.—All iron work to be painted one coat red lead before being fitted up and included in price for same

6 cast iron double columns of shop fronts, per drawings.....hundredweights	114-0-0
Cast iron L and J beams, per drawings, hundredweights	86-0-0
Cast iron box beams, per drawings.....hundredweights	25-0

12" x 5" rolled steel beams weighing 12 pounds per lineal foot, in lengths about 17'	lineal feet	<u>97-0</u>
10" x 6" rolled steel beams weighing 48 pounds per foot, in lengths about 15½'	lineal feet	<u>93-0</u>
10" x 6" rolled steel beams weighing 42 pounds per foot, in lengths about 17'	lineal feet	<u>204-0</u>
10" x 5" rolled steel beams weighing 28 pounds per foot, in lengths from 7' to 11'	lineal feet	<u>448-0</u>
8" x 6" rolled steel beams weighing 33 pounds per foot, in lengths from 11' to 15'	lineal feet	<u>156-0</u>
6" x 7" rolled steel beams weighing 23½ pounds per foot, lineal feet		<u>8-0</u>
5½" x 4½" rolled steel beams weighing 18 pounds per foot, in lengths under 10'	lineal feet	<u>86-0</u>
5" x 3" rolled steel beams weighing 10 pounds per foot, in 7'0" lengths	lineal feet	<u>63-0</u>
6" x 6" x ½" rolled steel Tees in 10½' lengths, lineal feet		<u>126-0</u>
3" x 3" x ¾" rolled steel Tees in 7'0" lengths, lineal feet		<u>11-0</u>
5" x 4½" rolled iron beams weighing 23 pounds per lineal foot, in 6'0" to 9'6" lengths	lineal feet	<u>311-0</u>
4" x 3" rolled iron beams weighing 12 pounds per lineal foot, in lengths from 4'6" to 9'0"	lineal feet	<u>243-0</u>
Labor raising and laying rolled steel beams weighing 42 pounds per lineal foot	lineal feet	<u>301-0</u>
Labor raising and laying rolled steel beams weighing 48 pounds per lineal foot	lineal feet	<u>93-0</u>
Labor raising and laying rolled steel beams weighing 33 pounds per lineal foot	lineal feet	<u>156-0</u>
Labor raising and laying rolled steel beams weighing 28 pounds per lineal foot	lineal feet	<u>448-0</u>
Labor raising and laying rolled steel beams weighing 23½ pounds per lineal foot	lineal feet	<u>8-0</u>
Labor raising and laying rolled steel beams weighing 18 pounds per lineal foot	lineal feet	<u>86-0</u>
Labor raising and laying rolled steel beams weighing 10 pounds per lineal foot	lineal feet	<u>63-0</u>
Labor raising and laying 6" x 6" x ½" Tees	lineal feet	<u>126-0</u>
Labor raising and laying 3" x 3" x ¾" Tees	lineal feet	<u>11-0</u>
Labor raising and laying rolled iron beams weighing 23 pounds per foot	lineal feet	<u>311-0</u>
Labor raising and laying rolled iron beams weighing 12 pounds per foot	lineal feet	<u>243-0</u>

1" machine stone coddings, sawn on edges, under beams	superficial feet	23-0
7/8" malleable iron circular stanchions of ground flat windows, run into stone at top and bottom with lead, lineal feet		604-0
2 1/2" X 1/2" malleable iron flat cross bars perforated for stanchions, and run in with lead	lineal feet	17-0
6 iron clothes poles for court, each 7'0" high with iron cross heads for rope, including fitting in with lead into stone		

Conditions

The whole materials to be of the very best quality, and the work done in the most complete and tradesmanlike manner to the entire satisfaction and directions of the proprietor and engineer, or any person appointed as inspector, who shall at all times be entitled to examine the work, and to reject or cause to be rejected all bad or defective materials or workmanship, but such examination shall in no way diminish, affect or impair the obligations of the contractor as regards the due and proper execution of the work in all respects. The proprietor and engineer reserve full power to make alterations on the plans or mode of executing the work, and to increase, lessen altogether omit any such portions of the work as may be thought proper.

The work will be measured when finished, and whether more or less than now estimated will be valued at the rates contained in this estimate, or others in strict proportion thereto, and in proportion to the slump sum of the Tender. The prices for extra work to which schedule rates do not apply to be revised and, if necessary, corrected by the measurer.

The contractor to pay half expense of schedules and measurements.

The proprietor may not accept the lowest or any offer.

Tender

Thomas Smith, Esq.

SIR:—I hereby offer to execute the excavator, mason, brick, iron and steel works of tenements and shops which you propose to erect in Fifth avenue, according to plans thereof by Mr. James Thomson, civil engineer, now shown, in conformity with, and to the extent of the foregoing estimate for the sum of

METHOD OF MEASURING BRICK WORK.

(1) Foundations measured thus.

Brick work in foundation (taking average course) 2 each
 $10.5 \times 2.0 \times 1.0 =$ cubic yards. 1-14-8

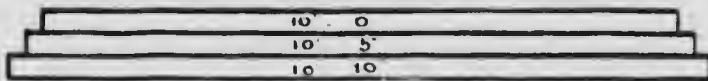

FIG. 6.

(2) Walls to be classed according to number of bricks in thickness, thus:

18", 14", 9" or 11½" thick.

(5 and 6) 14" brick wall 18-0 × 10-0
 14" brick projection of butts 2 each 4½ × 2-0 × 10-0
 14" brick projection of cornice 2½ × 18-5 × 0-4
 Superficial yards.

(7) 14" brick work in circular wall (measured round
 outside circumference) see fig. 8 16-0 × 20-0

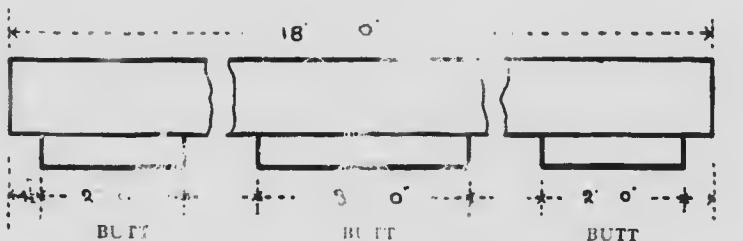
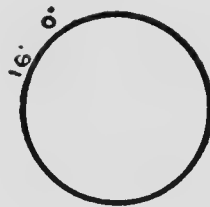

FIG. 7.

(8) Deduct daylight size of all through openings from walls and charge separately plumbing scuncheons (or sides), stating thickness and height by lineal foot.



F16.8.

(9) Plumbing scuncheons and forming checks of openings,	
2 each	6-0
18" brick wall	$30-0 \times 20-0 = 66-6-0$
Deduct 1 opening	$3-0 \times 5-0 = 1-6-0$
Gothic arch over opening	$3-0 \times 2-8 = 0-8-0$
1 opening	$3-0 \times 5-0 = 1-6-0$
Semi-arch over opening, semi of 3-0 dia.	0-3-6
1 opening	$3-0 \times 7-6 \times 2-4-6 = 7-1-0$
	Superficial yards <u>59-5-0</u>

In measuring gothic arched top take two-thirds for height—thus 1'0" high from spring of arch would be 2'8".

In measuring semi-circle arches multiply half diameter by same, thus:

Semi of 3-0 dia.	1-6
	1-6 multiply
	1-6
	0-9 add
	2-3
	<u>3½ multiply</u>
	6-9
	0-4 add

2) 7-1 area of circle
3'-6" area of semi circle

And multiply by 3½. Area of semi circle, superficial feet.

Plumbing scuncheons and forming checks of openings,	
4 each	$5-0 = 20-0$
2 each	$7-6 = 15-0$
	Lineal feet <u><u>35-0</u></u>

- Forming Gothic arch over 1 opening, one ring deep and 4½" thicklineal feet 9-0
 Forming semi-circular arch over 1 opening, one ring deep and 4½" thicklineal feet 10-6
 Forming 1 flat segmental arch over 1 opening, one ring deep and 4½" thick.....lineal feet 4-0
 (17) 9" brick work of chimney stalk22-0×9-0

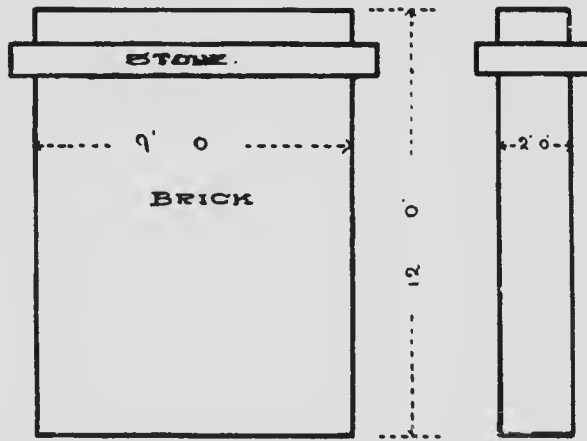

FIG. 9.

(30) Steam boiler seats and flues shall be measured by the cubic yard.

Brick building of boiler seat.....	25-0×6-0×8-0
Deduct boiler.....	22-0×6-0 dia.
	Cubic yards <u> </u>

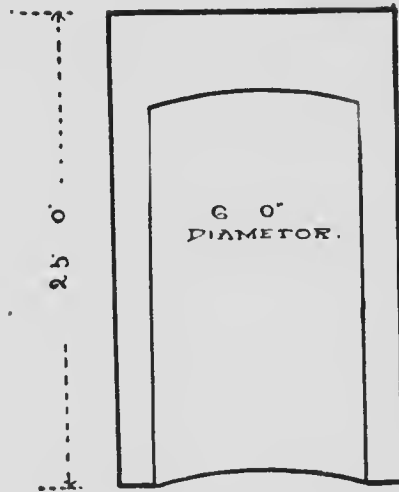

FIG. 10.

Chimney stalks for furnaces to be measured round the outside face at the start of the various thicknesses, each being stated separately by the superficial yard and described and taken by the lineal foot.

First Instance

18" brick building of bottom part of circular chimney stalk, average.....	18.0 x 30.0
11" brick building of circular chimney stalk above, average.....	14.0 x 20.0

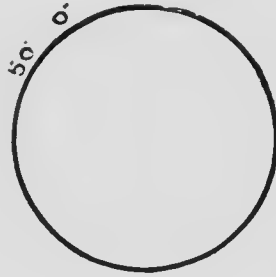
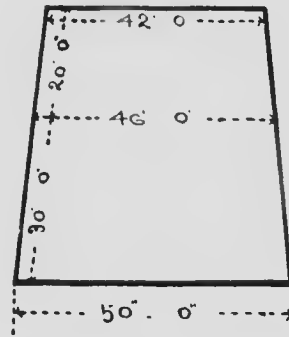

FIG. 11.



Second Instance

18" brick building of bottom part of circular chimney stalk,
 average 48' in circumference.....lineal feet 30-0

METHOD OF MEASURING CARPENTER AND JOINER WORK.

(21) Safelintel over 1 door 8-0×9×6. cubic feet	3-0
Safelintel over opening 13' long, 13-0×12×6. cubic feet	6-6
Safelintel over opening in circular wall, 4 pieces each 6' 0"×10" 6" cubic feet	10-0
(22) Taking delivery, carrying in, raising, staying, and racking 10 iron pillars each 12'0" high under beams	—
(23) 12"×6" sawn beam over opening lineal feet	<u>20-0</u>
Forming 2 scays on sawn beam over opening.	
Labor working chamfers on beams, 2 each. 20-0=	<u>40-0</u>
Forming 1 stop ends on chamfers.	

Beads, mouldings and channels measured similar to chamfers.

17"×1" wall plates under joists, including half checking at corners, 2 each.	40-0
4"×2" sleeper joists placed 18" to centers, 20 each.	10-0
9"×2" floor joists, 20 each 12-0=	<u>210-0</u>
9"×2" diagonal joists, including cutting other joists on each side, 2 each 20-0=	<u>40-0</u>
9"×1" bridle for joists, including dovetailing, morticing and tenoning, 2 each 6-0=	<u>12-0</u>
(27) Solid dwangs betwixt joists, 2 each. 30-0=	<u>60-0</u>
Iron rods through joists, 2 each 30-0=	<u>60-0</u>
4 screwed caps, nuts, heads and washers for iron rods	—

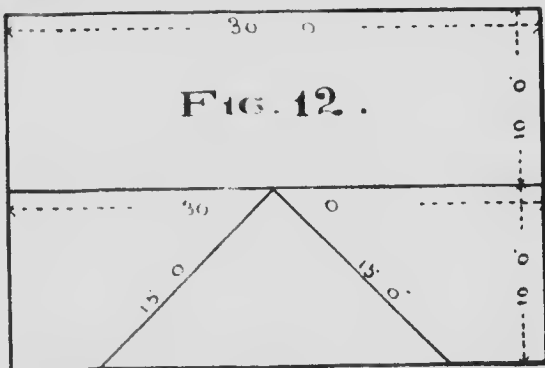
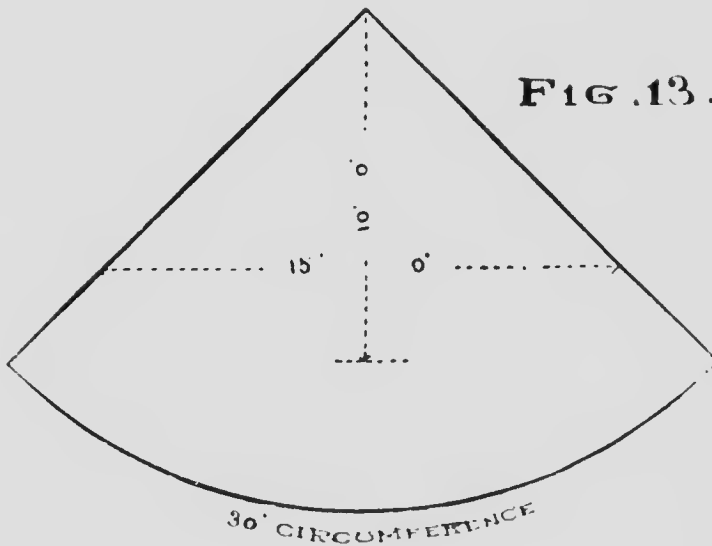

FIG. 12.

(28) Framed timbers in bound couples (including dove-tailing, morticing, and tenoning), 2 each.....	10-0=	20-0
Working chamfers, beads or mouldings, 2 each.....	10-0=	20-0
2 iron straps and bolts for bound couples.....		
Perforating timbers for 6 bolts.....		
Fitting and fixing iron work of 2 bound couples.....		
2" x 2" purlins (including checking at main rafters), 10 each.....	20-0=lineal feet	200-0
Common or purlin spars of roof, 2 sides, each.....	30-0 x 10-0	
Common or purlin cuttings, 2 each.....	15-0 x 0-9	
Deduct at pediment.....		6-0 x 5-0
		Superficial yards

(32) 9" x 1½" ridgeboard of roof.....	lineal feet	30-0
Flank plates at pediment, 2 each.....	15-0=	30-0



(33) 5/8" sarking on roof (same quantity as spar measurement).....		
5/8" sarking of circular roof.....	15-0 x 10-0	

(34) Balks are the timbers binding the spars, and the oxterpieces between the spars and ceiling joists.

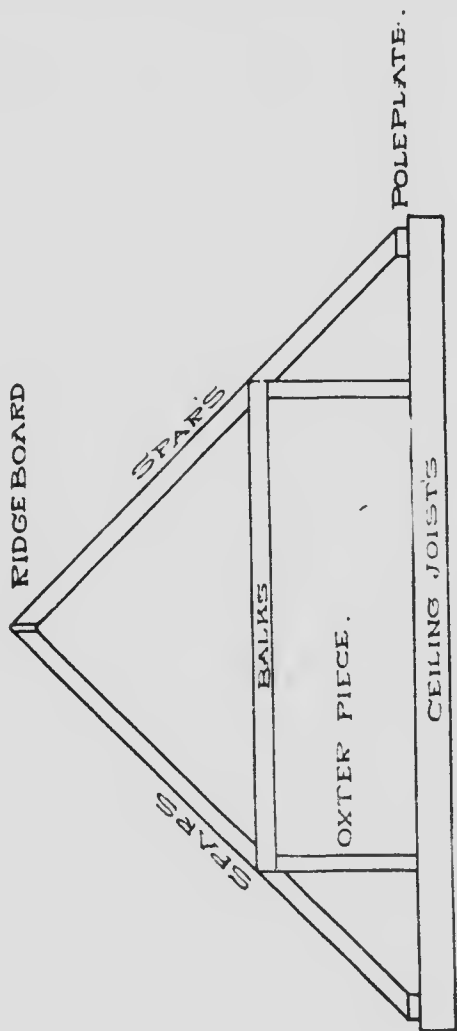

FIG. 14.

(35) 9" x 3" platform joisting
 placed 18" to centers, 10
 each 8-0 = 80 0

(36) Boarding on top of platform
 joisting 15-0 x 8-0 superficial
 yards 13 3 0
 Working bottle on edge

..... lineal feet 46 0

5/8" lining on soffit of roof projec-
 tion 10" broad..... lineal feet 120 0

Miters at angles, 4 each 1 3/4"
 lineal feet 5 0

50 cantilevers under roof projec-
 tions.....

6" x 5/8" facing on roof projec-
 tion..... lineal feet 120 0

4 miters on roof projection.....

(38) Gutter boarding in valleys
 between roofs, thus:—

Gutter boarding and bearers.....
 34-0 x 1-0 = 3 7 0

Gutter boarding and bearers addi-
 tional, 2 each..... 8-0 x 1-0 = 1 7 0
 Superficial yards 5 5 0

FIG. 15.

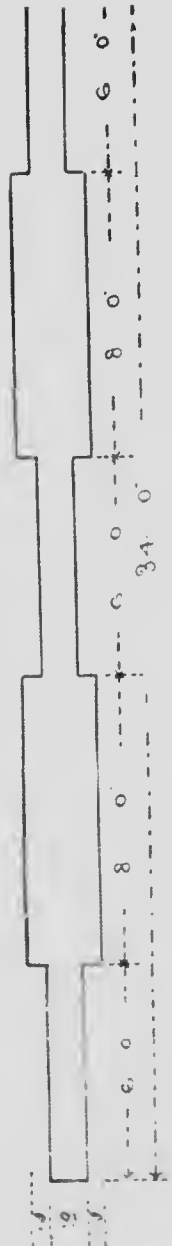

(39) 3"×2" spars and bearers of snow staging, 150 each,	
2-0	lineal feet 300-0
4"×2" top rail of roof light (including checking for	
astragals)	lineal feet 56-0
5"×2" bottom rail of roof light	lineal feet 56-0
3"×2" end rails, 2 each, 6-0	lineal feet 12-0
2"×2" astragals, checked on both sides for glass, 5 each,	
6-0	lineal feet 30-0

FIG. 16.

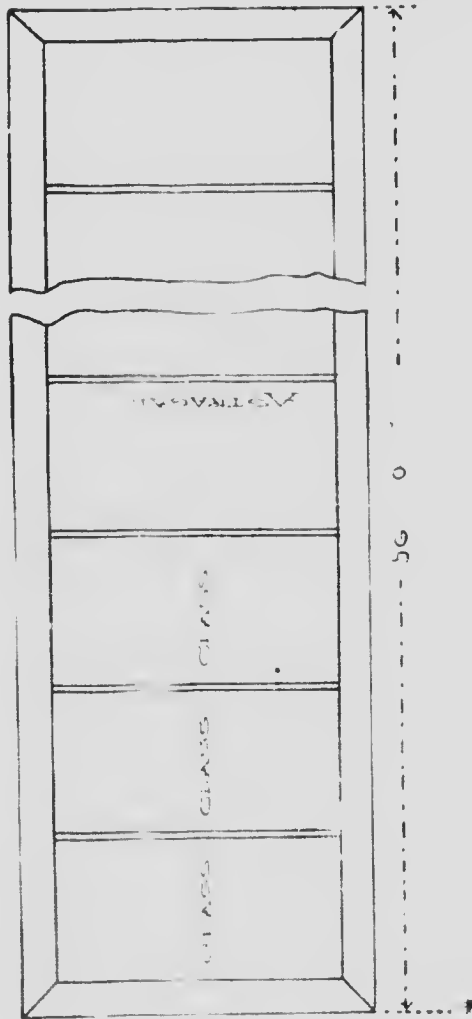

(41) 2 hatchboards with finishings on roof		
2 service boards		
(42) $\frac{5}{8}$ " boarding inside roofs	12.0	4.0
2" x 2" bearers under boarding, 6 each	1.0	24.0
(43) 1" safety boarding with fillets of floors, 3 each	30.0	25.0
Deduct at stairopen		6.0
9" partitions	120.0	0.9
		Superficial yards

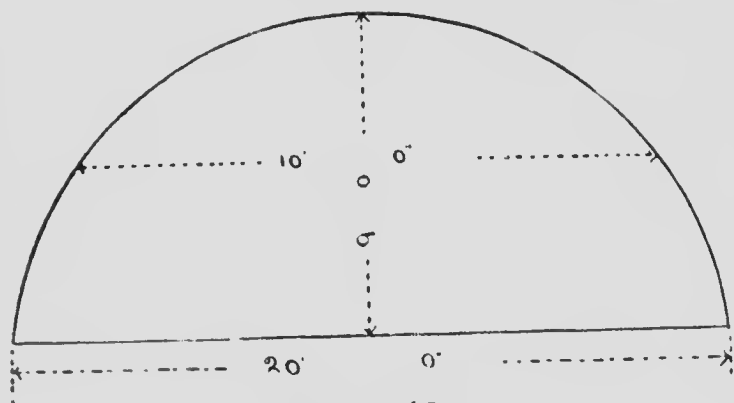

FIG 17.

(44) Straps for lath on walls	64.0	10.0
Deduct 1 window		2.0
1 door		3.0
		Superficial yards
Bracketing 3" x 2" and 11" to centers enclosing beam		
.....	36.0	3.0 = superficial yards
3" x 2" hangers from ceiling, 10 each		1.6 = lineal feet
(45) The prices for straps and grounds shall include the hooks or holdfasts driven into stone or brick work		
(46) Standard partitions dividing rooms (the standards placed 11" to centers)	132.0	9.0 = 132.0-0
Deduct 3 doors		each 2.0 x 6.0 = 1.0 = 1.0-0
		Superficial yards
4" x 2" runners and dwangs of partitions, 3 each	132.0	396.0
Deduct at doors 1.6		6.0
		Lineal feet
		<u>390.0</u>

(47) 3" x 2" ribs forming coved ceilings, 250 each 10-0=lineal feet.....	2500-0
(48) 3" x 2" bracketing for mock arches under ceiling, 30 each 2-0= lineal feet	90-0
3" x 2" bracketing for cornices placed 11" to centers..... lineal feet.....	60-0

NOTE: See longitudinal grounds and dooks for bracketing shall be included in the price.

(49) 15 blocks for gas pendants and brackets.....	_____
(50) 5/8" lath on ceilings, 3 each..... 120-0 x 10-0=	400-0-0
Deduct at staropens..... 2 each 6-0 x 3-0=	4-0-0
Deduct 9" partitions..... 120-0 x 0-9=	10-0-0
	386-0-0
Add on walls..... 3 each 260-0 x 9-0	780-0-0
	1166-0-0
Deduct 5 windows..... each 1-0 x 6-0=	10-0-0
6 doors..... each 3-0 x 8-0=	16-0-0
	1140-0-0
Lath on panelled ceilings..... 3 each 30-0 x 12-0=	120-0-0
Deduct roof windows..... 6 each 2-0 x 3-0	4-0-0
	116-0-0
Lath on dome..... 10-0 x 9-0=	10-0-0
1 1/8" flooring on joists..... 3 each 120-0 x 10-0=	400-0-0
Deduct staropens..... 2 each 6-0 x 3-0=	4-0-0
9" partitions..... 120-0 x 0-9=	10-0-0
	386-0-0
Traversing floors..... superficial yards	386-0-0
Labor butting flooring at reversed ends 6 each 10-0 lineal feet.....	60-0
3" x 2" dwangs and bearers for flooring at borders..... 250 each 6-0 lineal feet	300-0
Cutting and fitting flooring at 6 tile hearths.....	_____
Cutting and fitting flooring at 10 circular columns.....	_____
2 hatches in floors.....	_____
6 borders for tile hearths.....	_____
(52) 30 timber steps of stair, each 3-0 long including springboards, etc.....	_____
3 timber steps of wheeling stair, average each 3'6" long on extremes, including springboards, etc.....	_____

(54) 4"×4" timber newall post.....	lineal feet	6-0
12 turned balusters of railing, each 3-0 high.....	—	—
6 timber pedestals, each 4"×4" and 3-0 high.....	—	—
12 iron balusters each 1½"×1½" including thin iron strap at top, of outside stair.....	—	—
4"×2" moulded cope of handrail.....	lineal feet	20-0
1 scroll end of cope.....	—	—
(56) 10"×1½" dressed sides of trap stairs.....	2 each	10-0
23"×1½" dressed steps, ragged into sides.....	5 each 4-0=	20-0
(57) 5⁄8" white pine lining on ceiling.....	35-0×12-0	
5⁄8" white pine lining with grounds on walls.....	91-0×10-0=	104-4-0
Dednet at windows.....	6 each 2-0×4-0=	5-3-0
	Superficial yards	99-1-0
Working beads on angles of ingoings.....	.6 each 10-0=	60-0
(58) 2¼" window sashes with cases and astragals, including pulleys, etc.....	9 each 3-6×6-2=	194-3
Extra value for inside facings being broader than 4½" broad.....	18 each 6-2 lineal feet	121-0
(64) Extra for panelled or moulded facings opposite mallions.....	9 each 6-2=	55-6
(65) 4"×2" dressed framing of 2 shop windows and sidelights, top and bottom rails.....	4 each 6-0=	24-0
end rails.....	4 each 8-0=	32-0
	Lineal feet	56-0
3"×2" dressed astragals.....	2 each 8-0=	16-0
(66) 2" fixed sashes with astragals.....	—	—
.....	2 each 6-0×3-0 superficial feet	36-0
3×2 frames for sashes.....	2 each 18-0	—
2×5⁄8" dressed checks.....	2 each 18-0	—
(67) 2½" 2 windows each 3'0"×2'0" including frames and checks.....	—	—
(68) Extra for 6 windows having circled or pointed tops.....	—	—
(70) Fillets securing glass.....	2 each 18-0=	36-0
(72) 1¾" bound shutters with closers of windows.....	—	—
.....	2 each 12-0×6-0 superficial feet	144-0
1¾" bound linings of windows.....	4 each 2-0×6-0=	48-0
1¾" bound linings of soffits.....	2 each 10-6×2-0=	42-0
	Superficial feet	90-0



MICROCOPY RESOLUTION TEST CHART

ANSI and ISO TEST CHART No. 21



4.5
5.0
5.6
6.3
7.1
8.0
9.0
10
11.2
12.5



APPLIED IMAGE Inc

2601 E. 9th Ave.
Hialeah, FL 33010
Tel: (305) 881-1111
Fax: (305) 881-1112

6" x 5/8" dressed facings of windows.....	2 each	9-0	
1 1/2" x 1" dressed architraves.....	2 each	9-0	
2" staff beads.....	2 each	9-0	18-0
3" x 5/8" margin stiles.....	2 each	9-0	18-0
3" x 5/8" dressed copes.....	2 each	6-0	12-0
Putting on ironmongery of 2 windows with shutters....			
3 x 2-2 pair frames for doors with fixtures.....			
.....	4 each	6-0	24-0
(77) 4 iron bolts or batts for fixing frames.....			
(78) 8 dooks for door frames in brick, each 9" x 1 1/2" x 3 1/2"			
(79) Grounds for lining in thick walls.....	2 each	6-0	
2" 2 bound doors having 1 panels with sunk planted mouldings.....	2 each	2-0 x 6-1	25-4

Bound doors having circled or pointed tops shall be measured thus:

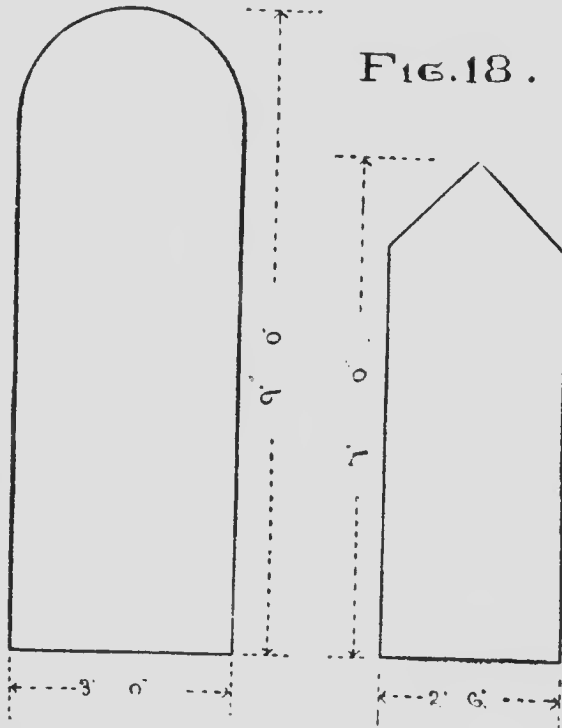

(83) Beads covering tenons on edge of doors.....			
.....	2 each	6-0	12-0

(84) Rounding edges of doors (including hollowing frames).....2 each 6-0 lineal feet	12-0
(85) Bars on back of plain doors..2 each 3-0 lineal feet	6-0
(86) Fitting and hanging 2 doors.....	—
(87) 2 pair base blocks to doors.....	—
2 pair facings to doors.....2 each 20-0=	40-0
(88) Putting on ironmongery of 2 doors.....	—
10" Moulded base in room.....lineal feet	36-0
4 miters on moulded base in room.....	—
Scribing to mouldings at 1 mantelpiece.....	—
(90) 10" beaded bellboard with fixtures.....lineal feet	40-0
(92) 1" shelves in kitchen.....150-0×1-0=	16-6-0
10"×1" shelves in kitchen.....3 each 6-0=lineal feet	18-0
Raggles and fillets under shelves..6 each 1-0=lineal feet	6-0
6 open brackets under shelves.....	—
(94) 6 sparred bed bottoms and bearers.....	—
10"×1" beaded bed stocks.....6 each 6-0 lineal feet	36-0
(97) 5/8" Lining with grounds on walls of room.....	—
.....36-0×4-6=superficial yards	18-0-0
(98) Drawers in dressers, bottoms...2 each 2-0×1-6=	6-0
sides and ends.....2 each 7-0×0-6=	7-0
Superficial feet	13-0
(99) 3"×5/8" spars forming shelves...6 each 6-0—lineal feet	36-0
(100) Slips on edge of lining...2 each 15-0 lineal feet	30-0
3"×5/8" coping.....lineal feet	6-0
Fillets and sliders for drawers.....lineal feet	10-0
(101) Cornices over shelves with blocks...lineal feet	10-0
2 mitres on cornices.....	—
(102) 2 Moulds for marble tops.....	—
Framed supports for 3 sinks.....	—
Framed supports for 3 basins.....	—
Framed supports for 3 water-closet seats.....	—
(103) 3"×2" framing under washing tubs.....	—
.....3 each 3-0 lineal feet	9-0
(104) Lining of bath-bottom.....16-0×3-0=	18-0
Lining of sides and ends.....18-0×2-6=	45-0
Superficial feet	63-0

Sinks, cisterns, washing tubs, etc., to be measured similar.

Cutting and rounding apertures for 2 closet seats.....	_____
Cutting and rounding apertures for 2 basin tops.....	_____
Fitting and hanging covers for 2 closet seats.....	_____
French polishing seats...2 each 1-6×2-0 superficial feet	6-0
10" pipe cover with grounds.....2 each 10-0 lineal feet	<u>20-0</u>
Checked and beaded grounds.....2 each 6-0 lineal feet	12-0
1" mahogany tops of counters...20-0×2-0 superficial feet	<u>40-0</u>
Rounding edge of counters.....lineal feet	<u>22-0</u>
(109) 2" bound front of counter.....	_____
..... 20-0×3-0 superficial feet	<u>60-0</u>
(110) 3"×2" dressed framing of counters.....	_____
top rails.....2 each 20-0=	40-0
standards.....10 each 3-0=	30-0
bottom rails...2 each 20-0=	40-0
cross rails....20 each 2-0=	40-0
lineal feet	<u>150-0</u>
10" moulded base.....lineal feet	<u>22-0</u>
10 mitres on moulded base.....	_____
(114) 3"×3" dressed heel and head posts of trevice ...	_____
6 each 6-0=	36-0
3"×5/8" dressed spars of racks.....10 each 6-0 lineal feet	<u>60-0</u>
(115) 2" trevice division, dressed both sides 10-0×8-0..	_____
Cutting division to curve.....lineal feet	<u>14-0</u>

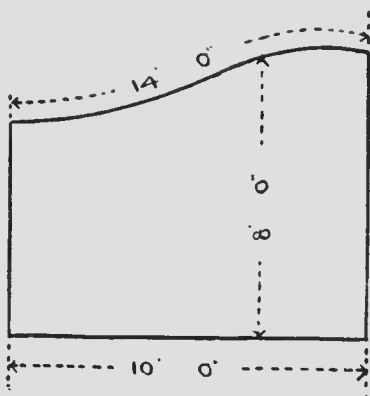

FIG. 19.

METHOD OF MEASURING GLAZIER WORK

Plate Glass

In measuring glass the extreme size to be taken for waste of material, thus:

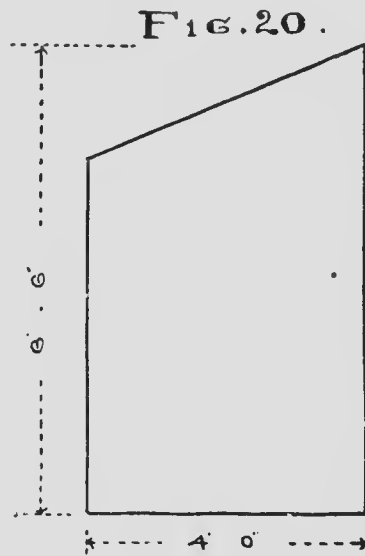

Plate glass in window.....	4-0×6-6
Grinding or polishing edges of plate glass, 2 each....	6-0
Forming polished chamfer 1" broad round edges of glass, 2 each	6-0

Lattice Work

Lattice work in compartments of windows:

1-2-0×7-6=	15-0
1-3-0×7-6=	22-6
Superficial feet	<u>37-6</u>

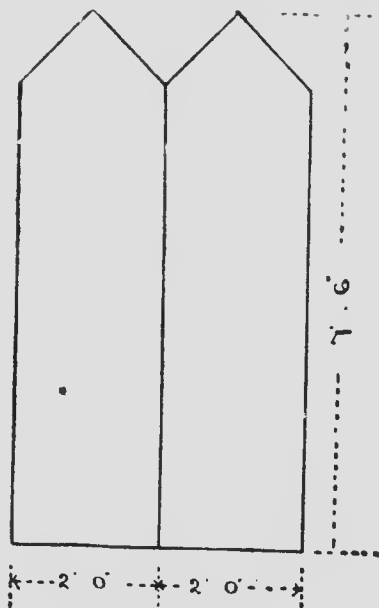

FIG. 21.

METHOD OF MEASURING SLATER WORK

Slater Work

Slates on roof north side...	28-6 × 24-0
Slates on roof south side...	28-6 × 30-0
Slates on roof ends, 2 each...	16-0 × 6-0
Allow at eave	34-0 × 0-9
Allow for cutting at piends, 4 each.....	32-0 × 1-6
Allow for cutting at pediments, 4 each.....	24-0 × 0-9
Deduct at pediments, 2 each.....	5-0 × 20-0
Add on pediment roofs, 4 sides each.....	12-0 × 5-0
Allow for cuttings at pediments, 4 each.....	24-0 × 0-9
	Superficial yards

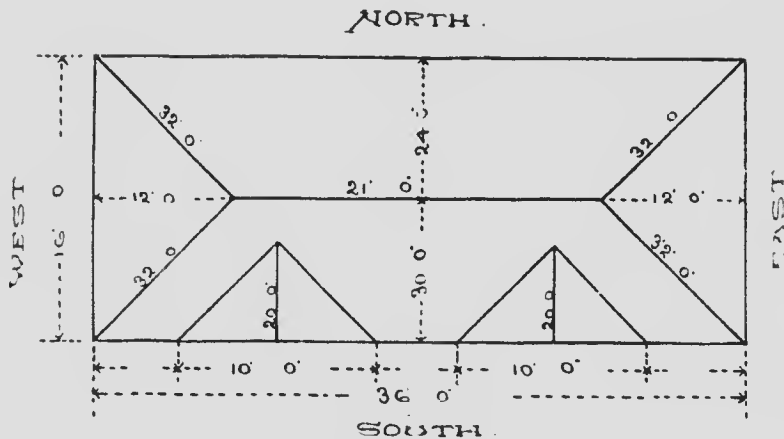

FIG. 22.

In measuring above roof average the eave with ridge thus:

$$\begin{array}{r}
 21-0 \\
 36-0 \\
 \text{Divide by 2) } 57-0 \\
 \hline
 28-6
 \end{array}$$

Measure ends taking the length of eave by half height:

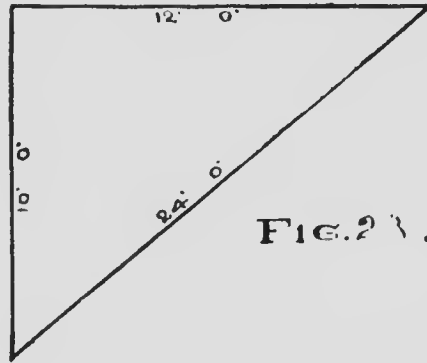

FIG. 23.

METHOD OF MEASURING PLASTER WORK

Begin at the upper floor of building, taking the ceilings and walls of each apartment, then the cornices and mouldings, center flowers or any other ornaments. Then each floor down, taking only the height of walls if apartments are divided off same as upper floor; thus saving the measurement of apartments; noting if any additional work or deductions are to be taken into account, thus:

15-0	3 coats plaster on ceiling of east front bed-rooms in two upper floors, 2 each.....	12-0 × 10-0	
35-0	3 coats plaster on ceiling of west front bed rooms in two upper floors, 2 each.....	10-0 × 7-6	
40-0	3 coats plaster on ceiling of east back bed rooms, 2 each.....	12-0 × 8-0	
31-0	3 coats plaster on west back bed rooms, 2 each.....	10-0 × 8-0	
156-0	3 coats plaster on walls of above rooms in two upper floors, 2 each ..	156-0 × 10-0	
	4 front windows..... each	3-6 × 8-0	_____
	4 back windows..... each	3-6 × 7-6	
	8 doors..... each	2-10 × 7-0	_____
12-0	Add on ceiling of east front room in ground flat.....	12-0 × 9-0=	
35-0	Add on ceiling of west room in ground flat.....	10-0 × 7-6=	
39-0	Add on ceiling of east back room.....	12-0 × 7-6=	
35-0	Add on ceiling of west back room.....	10-0 × 7-6=	
151-0	Add on walls of rooms ground flat ..	151-0 × 10-0	_____
Deduct	4 front windows..... each	3-6 × 7-6	
	4 back windows..... each	3-6 × 7-6	
	8 doors..... each	2-10 × 7-0	
	Superficial yards		_____

Cornices are taken at the extreme lengths and miters and projections are enumerated thus:

7"×6" cornice of roomlineal feet 39 0
 4 miters on cornice of room No. 1

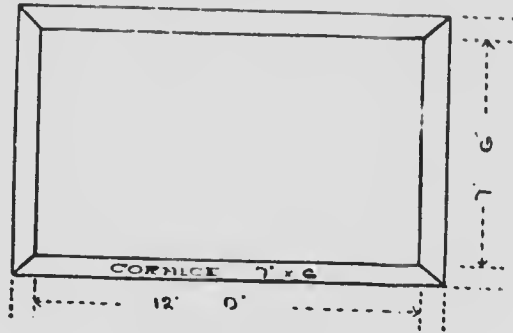

FIG. 24.

8" x 6" cornice of room No. 2

Length of cornice taking the extreme points, thus:

15-0	
20-0	
35-0	
2	Multiply.
70 0	
6 0	Projections, add.
76 0	Lineal feet

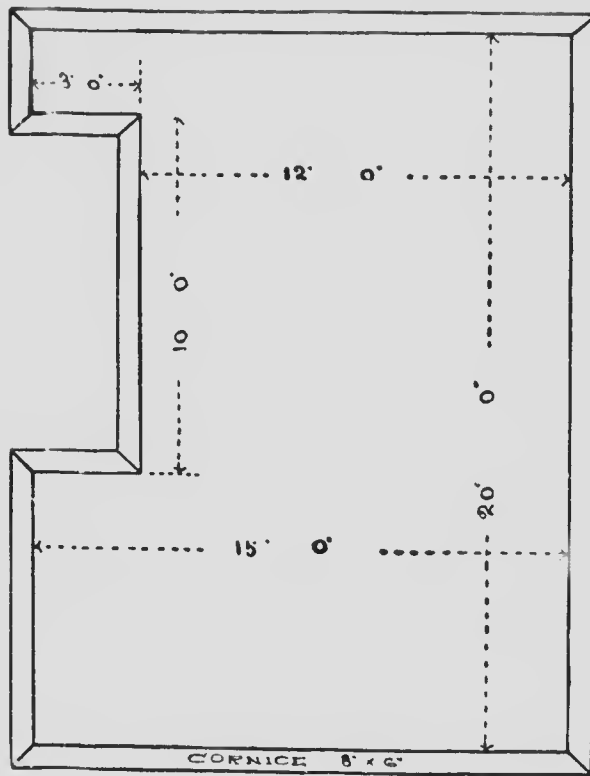

FIG. 25.

8 miter on cornice.....
 1 center flower 3' diameter

ESTIMATE OF THE SLATER WORK OF TENEMENTS AND SHOPS

Slating roofs with best slates, three-fourths square dressed, bored 1½" from top, to have 3" of cover at eaves, gradually diminishing to 2" at ridge, put on with galvanized steel nails weighing 12 lbs. per thousand, every course to be double nailed with galvanized nails, and all to be properly bonded and shouldered with haired lime where necessary. square yards	720 0-0
Cutting slates at angled skew. lineal feet	50 0
Pointing raggles with best mastic and oil. lineal yards	108 0 0
53 beaded fire clay chimney pots each 12" high, set and pointed with Portland cement	
Repairing roofs after tradesmen are finished and upholding same for 12 months from date of completion	

Conditions

The whole materials to be of the very best quality and the work done in the most complete and tradesmanlike manner to the entire satisfaction of the proprietor and architect or that of any person appointed to inspect the work.

The proprietor reserves full power to make alterations on the plans or mode of executing the work, and to increase, lessen or altogether omit any part of the work he may deem expedient.

The work will be measured when finished and whether more or less be done than now estimated, the same will be valued at the rates contained in this estimate, or others in strict proportion thereto, and in proportion to the lump sum in tender. The prices for extra work to which schedule rates do not apply to be revised, and if necessary corrected by the engineer. The contractor to pay half expense of schedules and measurements.

The proprietor does not bind himself to accept the lowest or any offer.

Tender

Thomas Smith, Esq.

SIR: I hereby offer to execute the slater work of the tenements and shops which you propose to erect in Fifth Avenue according to plans thereof by Mr. James Thomson, civil engineer, now shown, in conformity with and to the extent of the foregoing estimate for the sum of

Your acceptance of this offer will be binding on

Your obedient servant.

ESTIMATE OF LATHER AND PLASTER WORKS

3/4 laths best Baltic split lath on ceilings and walls, also enclosing beams, butt jointed and broken, banded every 2 1/2 feet	superficial yards	2000 0 0
Deafening with a 1/4 coat of plaster lime, covered with 2 1/2" clean, dry riddled engine or smithy ashes, and one coat plaster on top	superficial yards	1200 0 0
1 coat plaster under wood linings	superficial yards	400 0 0
3 coats plaster on ceilings and walls, hand floated, hard finished and well polished off	superficial yards	6000 0 0
Portland cement on lower walls of staircase, finished smooth	superficial yards	210 0 0
Forming sunk bead at top of cement	lineal feet	480 0
Finishing underside of concrete landings, etc., with best Portland cement	square yards	150 0 0
7" x 6" moulded cornice in shops	lineal feet	1200 0
6" x 4 1/2" moulded cornice in rooms	lineal feet	900 0
5" x 4" moulded cornice in lobbies, stairs and cresses	lineal feet	1200 0
192 miters on 7" x 6" cornices		
180 miters on 6" x 4 1/2" cornices		
150 miters on 5" x 4" cornices		
18 moulded return ends of cornices, including miters		
18 enriched center flowers each 18" diameter on ceilings of rooms		
18 plain center flowers each 9" diameter		
Forming arrises on angles	lineal feet	600 0
Forming rounded corners and back of steps	lineal feet	1200 0
Forming 33 moulded stops with arris at top of rounded corners		
Relieving corner beads	lineal feet	120 0
110 window cases bedded in lime and pointed with best mastic and oil		
6 small window cases bedded in lime and pointed with best mastic and oil		
Repairing all broken plaster work after the other tradesmen are finished and upholding same for 12 months after completion		

Conditions

The lime for the first two coats to be the very best and mixed in the most approved proportions with clean, sharp sand, long fresh hair, and pure water, and the whole carefully wrought and prepared. The third coat to be run Irish lime mixed with white shiver sand, and the whole to be finished straight and smooth, and perfectly free from cracks, blisters or other imperfections.

The whole materials to be of the very best quality, and the work done in the most complete and tradesmanlike manner to the entire satisfaction of the proprietor and architect or that of any person appointed to inspect the work.

The proprietor reserves full power to make alterations on the plans or mode of executing the work, and to increase, lessen or altogether omit any part of the work he may deem expedient. The work will be measured when finished and whether more or less than now estimated, will be valued at the rates contained in this estimate or others in strict proportion thereto, and in proportion to the slump sum of the tender.

The prices for extra work to which schedule rates do not apply, to be revised, and if necessary, corrected by the engineer. The contractor to pay half expense of schedules and measurements.

The proprietor may not accept the lowest or any offer.

METHOD OF MEASURING PLUMBER WORK

In measuring Plumber Work, firstly, measure all roof work, such as ridges, peends, flanks, gutters, lead round chimney-stalks.

Then measure all rain water pipes, eave rhones and any supply or discharge pipes outside of walls. Then take the inside work beginning at the upper floor, such as baths with their finishings and pipes connected, cisterns, water closets, hot water tanks, and all inside pipes. Then take the other floors in similar manner. Then all supply or other pipes outside of building.

ESTIMATE OF THE PLUMBER WORK

7 lb. sheet lead lining gutters	18-0-0
6 lb. sheet lead on ridges, peends and flanks.....	32-0-0
5 lb. sheet lead aprons at skews, chimney stalks, etc.....	20-0-0
	Cwts. <u>70-0-0</u>
Lead batts in raggles 1'4" long and not more than 6" apart	lineal feet <u>324-0</u>
110 strong galvanized iron straps, each 16" long, fixing lead on ridges and peends.....	
5" x 1" cast iron moulded gutter, made of 1/4" metal, bolted and jointed with red lead and firmly screwed on wood facing.....	lineal feet <u>120-0</u>
5" x 1" 18 cast iron moulded close ends.....	
6 cast iron moulded drops or outlets.....	
13 heavy copper rose gratings on gutters at top of pipes	
3" bends from gutters made of 6 lb. lead.....	lineal feet <u>25-0</u>
4 2" x 3 1/2" cast iron  conductors made of 1/4" metal lineal feet	<u>192-0</u>
1 1/2" x 3 1/2" 4 cast iron bends at bottom.....	
28 cast iron ornamental ears fixed with spikes.....	
1 cast iron ornamental cistern heads, each 17 1/2" x 12 3/4" on face and projecting 9 1/4" per drawing.....	

3" cast iron round conductors and waste pipes from jaw-boxes made of $\frac{1}{4}$ " metal, fixed with strong holdfasts, and jointed with red lead puttylineal feet	<u>438-0</u>
9 cast iron single bends or shoes at bottom	
6 cast iron 3" offsets at top	
27 cast iron branch pieces for waste pipes	
27 cast iron branch horns cast on for waste pipes	
4 $\frac{1}{2}$ " cast iron soil pipes made of $\frac{1}{4}$ " metal, jointed with oakum and red lead and fixed with strong holdfasts, lineal feet	<u>220-0</u>
6 cast iron bends with heel rests at bottom	
24 cast iron horns for branches	
24 cast iron branch pieces	
4 $\frac{1}{2}$ " cast iron light air pipe $\frac{1}{4}$ " metal above soil pipe, lineal feet	<u>72-0</u>
6 cowls on top of air pipe, as per drawing	
3" waste pipes made of 6 lb. leadlineal feet	<u>95-0</u>
5" branch soil pipes made of 7 lb. leadlineal feet	<u>120-0</u>
27 white enameled fire clay sinks each 27" \times 18" \times 10" outside, of the finest quality with overflow	
3" 27 hydraulic drawn 5" traps made of 7 lb. lead with brass cleansing screws	
3 $\frac{1}{2}$ " 27 brass table washers with plug and chain in fire clay sinks	
5 $\frac{3}{8}$ " 27 heavy brass nose cocks	
27 collars made of 7 lb. lead connecting fire clay horns to lead waste pipes	
6 plain whiteware table top wash-hand basins each 16" diameter inside, supported on two ornamental iron brackets and having lion's head, S cesspool of 6 lb. lead and approved supply and discharge apparatus for cold water, with 6 lb. lead rod, overflow and tapered waste pipes complete	
Extra for 6 basins having brass pillar fount with flange	
24 Shanks first quality "Citizen" flushdown fire clay water-closets in one piece, white inside, and buff outside, of strong thick ware, having broad lip fitted up complete	
24 collars made of 8 lb. lead, connecting fire clay horns to lead soil pipes	

24 brass nipples each 5" diameter and 6" long of 1/8" metal connecting lead and iron soil pipes	
24 Doulton's patent iron improved three gallon vacuum syphon cisterns	
18 cast iron brackets including fitting up with screws...	
3/4" 24 brass knees with jam nut for overflow.....	
1 1/2" galvanized iron service pipes to water-closets, screwed and coupled at joinings with holdfasts, lineal feet:.....	168-0
Labor only forming 24 offsets on service pipes.....	
3/4" patent lead supply pipes weighing 11 lbs. per lineal yard.....lineal feet	950-0
1/2" patent lead supply pipes weighing 7 lbs. per lineal yard	560-0
6 brass underground stop cocks on supply pipe.....	
6 brass screwed ferrules	
3 cast iron stop cock cases.....	
3 cast iron horse-shoe covers.....	
3/4" 3 brass cleansing cocks with coupling tails	
1 malleable iron stop cock key.....	

Conditions

Maintaining the plumber works in perfect condition during the progress of the work, making good from time to time any damaged or imperfect work from whatever cause arising, from theft, storm, fire, tradesmen's operations, accidents of every kind, and after the several tradesmen finish, overhauling the work, and leaving the work in a perfect condition.

The lead to be of the best soft-milled English kind, and the prices to include all charges for carriage, solder, holdfasts, workmanship and every other expense necessary for the thorough completion of the work. The whole materials to be of the very best quality, and the work done in the most complete and tradesmanlike manner to the entire satisfaction of the proprietor and architect or that of any person appointed to inspect the work. The proprietor reserves full power to make alterations on the plans or mode of executing the work, and to increase, lessen or altogether omit any part of the work he may deem expedient. The work will be measured when finished and whether more or less than now estimated, will be valued at the rates contained in this estimate or others in strict proportion thereto, and in proportion to the slump sum of the tender.

The prices for extra work to which schedule rates do not apply to be revised, and if necessary corrected by the engineer. The contractor to pay half the expense of schedules and measurements. The proprietor may not accept the lowest or any offer.

ESTIMATE FOR TILE LININGS

Pure enameled tiles in 6" squares, cream, buff or other approved color on lower walls of closets, set in bed of pure Portland cement, mixed without sand, superficial yards	<u>130-0-0</u>
Ornamental enameled border 3" broad, of approved pattern, set in bed of pure Portland cement, mixed without sand.....lineal feet	<u>210-0</u>
Enameled corner beads on angles.....lineal feet	<u>40-0</u>
9 enameled corner pieces of 3" ornamental border...	
Cutting tiles at vertical and raking angles, including for loss of material.....lineal feet	<u>183-0</u>
Extra for dark base 6" high, chocolate or other approved color.....	<u>210-0</u>
Cutting and fitting tiles to moulded breasts of 36 steps..	

Maintaining the tile linings in perfect condition during the progress of the work, making good from time to time any damaged or imperfect work from whatever cause arising, from theft, storm, fire, tradesmen's operations, accidents of every kind, and after the several tradesmen finish overhauling the work, and leaving tile linings in a perfect condition.

METHOD OF MEASURING PAINTER WORK

In measuring Painter work begin with the ceilings and walls of apartments, stating the material used, whether oil paint or any other, then measure all wood, iron or stone work. Measure the cornices and other ornaments after the walls. In all cases state the number of coats used in painting.

ESTIMATE FOR PAINTER WORK

1 coat oil paint and size tinting ceilings. superficial yards	1770-0-0
Size color on walls superficial yards	<u>3200-0-0</u>
3 coats oil paint in shades on plain cornices, girding from 12" to 20" lineal yards	<u>1100-0-0</u>
3 coats oil paint in shades on 18 enriched centerflowers, each 18" diameter.	
3 coats oil paint in shades on 18 plain centerflowers, each 9" diameter.	
3 coats painting in shades on 9 circular iron pillars each girding 24" and 12' high, having stenciled ornament at joining of colors.	
Imitation rich dark flowered oak with 3 coats ground and 1 coat varnish on woodwork of rooms, lobbies, etc. superficial yards	<u>950-0-0</u>
Imitation rich dark flowered oak, with 3 coats ground, and 1 coat varnish on skirtings and beltings girding from 6" to 9" lineal yards	<u>420-0-0</u>
3 coats painting on rest of woodwork, walls of lobbies, and lower walls of kitchens, sculleries and stairs, superficial yards.	<u>2000-0-0</u>
3 coats painting on skirting and beltings, girth 6" lineal yards	610-0-0
Drawing black line at top of lower walls. lineal yards	<u>600-0-0</u>
1 coat staining in shades with dark mouldings and 3 coats varnish on woodwork of shops, superficial yards	<u>1180-0-0</u>
1 coat staining in shades with three coats of varnish on staff heads, girding 3 1/2" lineal yards	<u>130-0-0</u>

Painting vermilion and varnish on edges of shelves, lineal yards	320-0-0
3 coats painting approved color on 18 iron chimney pieces.....	
3 coats painting black on 33 kitchen chimney jambs, lintels and shelves.....	
Supplying 144 pieces paper (value 30 cents per piece) for walls of rooms	
Hanging 144 pieces, including for sizing walls previously.	
3 coats painting bronze green on stair railings, iron stanchions of gates and borrowed lights (measured on two sides).....square yards	40-0-0
3 coats painting on outside woodwork, etc.....square yards	120-0-0
3 coats painting on framing, girth 6" of shop front lineal yards	225-0-0
3 coats painting on framing, girth 9" of shop front lineal yards	20-0-0
3 coats painting on iron gutters	40-0-0
3 coats painting on conductors and soil pipes lineal yards	30-0-0
3 coats painting on 32 ornamental ears.....	
3 coats painting on 3 iron cistern heads	
3 coats painting on 6 iron clothes poles	
3 coats painting on 29 iron ventilation gratings.....	
2 coats painting on outside of 147 window.....	
2 coats painting on outside of 6 small windows.....	
2 coats painting on iron stanchions of 18 windows.....	

Conditions

The work to be finished plain or parti-colored and in oil or flatted as required. The prices must include all charges for puttying, polishing and every other expense necessary for the thorough completion of the work.

The work to receive the full number of coats of best white lead and oil paint, and no size to be used in connection with paint on any pretence whatever.

The whole materials to be of the very best quality, and the work done in the most complete and tradesmanlike manner to the entire satisfaction and directions of the Engineer or any person appointed as Inspector, who shall at all times be entitled to examine the work, and to reject or cause to be rejected all bad

or defective materials or workmanship, but such examination shall in no way diminish, effect or impair the obligations of the Contractor as regards the due and proper execution of the work in all respects.

The Proprietor reserves full power to make alterations on the plans or mode of executing the work, and to increase, lessen or altogether omit any such portions of the work he may deem expedient. The work will be measured when finished and whether more or less than now estimated will be valued at the rates contained in this estimate, or others in strict proportion thereto, and in proportion to the slump sum of the tender.

The prices for extra work to which schedule rates do not apply, to be revised, and if necessary, corrected by the Engineer. The Contractor to pay half expense of schedules and measurements. The Proprietor may not accept the lowest or any offer.

FORM OF MEASUREMENT FOR MASON AND BRICK WORKS

Excavating earth in area and trenches for foundations	36-0×9-0×4-0
Excavating earth in area and trenches for foundations	54-0×9-0×6-0
Excavating earth in area and trenches for foundations	66-0×8-0×7-0
Excavating earth in area and trenches for foundations	80-0×7-0×6-0
Excavating earth in area and trenches for foundations	95-0×7-0×8-0
Excavating earth in area and trenches for foundations	54-0×8-0×4-0
Excavating earth in area and trenches for foundations	73-0×8-0×3-0
	<u>Cubic yards</u>
Concrete foundations under outer walls	36-0×5-0×4-0
Concrete foundations under outer walls	54-0×4-0×3-0
Concrete foundations under outer walls	28-0×3-6×2-6
Concrete foundations under outer walls	36-0×2-6×1-6
Concrete foundations under outer walls	27-0×3-0×2-0
Concrete foundations under outer walls	37-0×2-6×1-4
	<u>Cubic yards</u>
Brick work in foundations of walls	39-0×2-6×3-0
Brick work in foundations of walls	47-0×2-6×2-6
Brick work in foundations of walls	29-0×2-6×2-0
	<u>Cubic yards</u>
Hammer dressed stone foundations of iron pillars	3 each 3-0×3-0×3-0
Hammer dressed stone foundations of iron pillars	4 each 2-6×2-6×2-6
Hammer dressed stone foundations of iron pillars	4 each 2-0×2-0×2-0
Hammer dressed stone foundations of iron columns	2 each 3-0×2-0×1-6

Hammer dressed stone foundations of iron
 columns 2 each 4-6×1-6×1-9
 Hammer dressed stone foundations for
 iron columns 3 each 2-0×1-6×1-0
Cubic feet

Droved hewing on top of foundations ... 3 each 3-0×3-0
 Droved hewing on top of foundations ... 4 each 2-6×2-6
 Droved hewing on top of foundations ... 4 each 2-0×2-0
 Droved hewing on top of foundations of iron
 columns 2 each 3-0×2-0
 Droved hewing on top of foundations of iron
 columns 2 each 4-6×1-6
 Droved hewing on top of foundations of iron
 columns 3 each 2-0×1-6
Superficial feet

Bedded soleplates of 18 iron pillars
 Rubble seats under 9 hearths each about 2' high
 2' rubble building of front wall of main
 building 30-0×36-0
 2' rubble building of front wall of main
 building 9-0×24-0
 2' rubble building of front wall of main
 building 8-6×12-0
 2' rubble building of gables 2 each 26-0×36-0
 2' rubble building gable tops 2 each 26-0× 9-0
 2' rubble building of back wall 30-0×36-0
 2' rubble building of back wall 27-0× 9-0
 2' rubble building of back wall 8-0× 7-6
 Deduct 12 windows, front wall each 3-0× 7-0
 4 doors, front wall each 2-6× 6-0
 8 windows in gable each 3-0× 7-6
 4 doors in gable each 2-6× 7-0
 12 windows in back wall each 3-0× 7-6
 4 doors in back wall each 2-6× 6-0
Superficial yards

Hammer dressed out and inband corners of
 walls 1 each 36-0
 1 1/4" Caithness pavement damp course on walls... 30-0×2-0
 1 1/4" Caithness pavement damp course on walls... 9-0×2-0
 1 1/4" Caithness pavement damp course on walls... 8-6×2-0

1 1/4" Caithness pavement damp course on walls	1 each 26-0x2-0	
1 1/4" Caithness pavement damp course on walls	30-0x2-0	
1 1/4" Caithness pavement damp course on walls	27-0x2-0	
1 1/4" Caithness pavement damp course on walls	8-0x2-0	
	Superficial yards	
1 1/4" Caithness pavement damp course on dwarf partitions, 9" broad	lineal feet	300-0
Cube stone piers of shop front	2 each 2-6x2-0x6-0	
Cube stone piers of shop front	2 each 2-6x2-0x7-6	
Cube stone piers of shop front	2 each 2-6x2-0x8-0	
	Cubic feet	
Striped hewing on sides	2 each 2-0x6-0	
Striped hewing on sides	2 each 2-0x7-6	
Striped hewing on sides	2 each 2-0x8-0	
	Superficial feet	
Striped checked hewing on sides	2 each 2-0x8-0	
Striped checked hewing on sides	2 each 2-0x7-6	
	Superficial feet	
Polished plain hewing on sides	2 each 2-0x3-0	
Polished plain hewing on sides	2 each 3-0x1-6	
Polished plain hewing on sides	2 each 4-0x2-0	
	Superficial feet	
Labor working polished splays 3" broad on bases, lineal feet		20-0
Extra for 8 miters on splays		
Extra for moulding under trusses at top of shafts, including extra size of stone and hewing	lineal feet	8-0
Labor working 8 polished moulded and fluted trusses, as per drawing		
Labor raising and setting 6 cast iron double columns each about 12' high of shop front		
Labor raising and setting 9 circular pillars, each 12' high and sole and top plates		
Labor raising and laying cast iron L and J beams, lineal feet		147-0
Labor raising and laying cast iron box beams, lineal feet		27-0
Cube stone cornice over shop front, 30-0x3-0x1-0 cubic ft.		90-0

Polished plain hewing on stone cornice over shop front 30-0×2-0	superficial feet	<u>60-0</u>
Polished moulded hewing on stone cornice, over shop front, 30-0×1-0	superficial feet	<u>30-0</u>
Labor mitering and returning upper and lower mem- bers of cornice at top of 4 stone piers		
16"×8" polished plain sill course above cornice, gird- ing 17"	lineal feet	<u>50-0</u>
16"×15" polished plain sill course above cornice, serv- ing as window sills, girding 31" in stones 6'3" long, lineal feet		<u>20-0</u>
Extra material and labor forming 4 semi circled and moulded pediments, each 33"×12" on face over trusses		
Labor perforating cube stone for conductors, lineal feet		<u>60-0</u>
10"×6" polished moulded sill course, girding 11", lineal feet		<u>57-0</u>
18"×6" polished moulded sill course, serving as window sills, girding 28"	lineal feet	<u>18-0</u>
Labor perforating, mitering and returning sill course at 3 conductors		
Extra for 3 circled pieces moulded sill course including miters as per drawing		
4 polished moulded stones, each 20"×15" on face and projecting 6", perforated, mitered and retained round conductors		
Hammer dressed stone cornice at wallhead 10" thick and 33" broad, including building, 30-0×2-9	square feet	<u>82-6</u>
Hammer dressed stone cornice at wallhead 10" thick and 21" broad, 20-0×1-9	square feet	<u>35-0</u>
Polished moulded hewing on stone cornice, 50-0×5-6 square feet		<u>275-0</u>
2 plain stop ends		
40 miters of moulded cornice		
6 polished projecting stones at ends of cornice at sides of pediments, having peended face, including material, hewing and building as per drawing		
Labor cutting gutter in cornice	lineal feet	<u>130-0</u>
Labor perforating 4 drip holes in 10" cornice		

Oriol Windows

16"×15" polished plain sill course girding 31", lineal feet	66-0
18"×6" polished moulded sill course girth 28", lineal feet	180-0
18 miters of moulded sill	
Labor checking sill course for iron T beams, and grouting with Portland cement	66-0
Polished moulded cornices, girding 20", lineal feet	102-0
24 miters on moulded cornices	
13"×12" polished moulded lintels girding 21", 40 each 5-0 lineal feet	200-0
Labor working 72 returns of moulded lintels for rybats and mullions	
12" polished ashlar dados 60-0×5-0, square feet	300-0
Polished out and inband projected jambs in stones 30"×12" and 20"×15" alternately with bead moulding on arris, 40 each 5-0 lineal feet	200-0
12"×12" polished angular mullions in stones from 6'3" to 6'9" long 40 each 5-0 lineal feet	200-0
Square dressed rubble of back wall, 40-0×15-0 superficial yards	360-0-0
Out and inband corners in 2" walls, 2 each 41-0 lineal feet	82-0
Out and inband corners in 1'6" wall, 2 each 7-0 lineal feet	14-0
16"×6" droved projected plinth at back wallhead, lineal feet	54-0
Droved out and inband rybats, 60 each 5-0 lineal feet	300-0
Droved out and inband rybats in 1'6" wall, lineal feet	8-0
13"×10" droved checked lintels, 32 each 4-0 lineal feet	128-0
14"×6" droved projecting window sills, girding 22", 32 each 4-0 lineal feet	128-0

Brick Work

18" brick south gable	35-0×45-0=	315-0-0
18" brick inner gables	2 each 32-0×45-0=	320-0-0
18" brick inner gables	2 each 32-0×40-0=	284-4-0
	Superficial yards	919-4-0
22" brick north gable	35-0×45-0=	315-0-0
11" brick back wall at staircases	36-0×10-0 square yards	160-0-0
9" brick walls of back wings	2 each 18-0×10-0=	160-0-0
	4 each 16-0×10-0=	284-4-0
	Superficial yards	444-4-0

9" brick dwarf walls under sleepers...80-0×4-6 sup. yds.	<u>40-0-0</u>
4½" brick partition ground floor ... 350-0×9-0=	<u> </u>
4½" brick partition three upper floors ... 450-0×36-0=	<u> </u>
Deduct 36 doors.....each 2-6×7-0	<u> </u>
Superficial yards	<u> </u>
Plumbing plain scunchions 11" broad, 205 each 4-0,	
lineal feet.....	<u>820-0</u>
Plumbing plain scunchions 4½" broad, 110 each 4-0,	
lineal feet.....	<u>440-0</u>
Forming 36 openings for ventilation in 4½ brick parti-	
tions, per plan.....	<u> </u>
Forming checks and plumbing scunchions in 9" walls	
lineal feet.....	<u>618-0</u>
Plumbing angles of walls, 10 each 23-9.....lineal feet	<u>230-0</u>
Labor cutting 18" gable tops at angle, including for	
loss of material.....lineal feet	<u>84-0</u>
Labor cutting 14" gable tops at angle, including for	
loss of material.....lineal feet	<u>30-0</u>
Labor cutting 9" gable tops at angle, including for loss	
of material.....lineal feet	<u>21-0</u>
Extra for rounded brick at angles.....lineal feet	<u>1200-0</u>
Vents in brick gables, smoothly plastered with lime,	
lineal feet.....	<u>1420-0</u>
9" brick building walls of ashpit pointed with Arden	
lime and key drawn, 21-0×9-0.....square yards	<u>21-0-0</u>
Cutting brick at skews.....lineal feet	<u>12-0</u>
Plumbing plain scunchions 9" broad.....lineal feet	<u>11-0</u>
Plumbing external angles.....lineal feet	<u>26-0</u>
Slate slab breast of ashpit, 4-6×2-0.....superficial feet	<u>9-0</u>

Dressings of Brick Walls

Facing wall of back wings, 356-0×9-0.....superficial yards	<u>356-00</u>
Extra for forming semi-circular arch tops of 3 openings,	
each 3' span daylight in 9" brick walls.....	<u> </u>
11"×6" polished plain projected plinth on wallhead,	
lineal feet.....	<u>60-0</u>
Polished plain hewing on 6 ends of plinth on wall head..	
11"×6" polished projected sills to windows, 16 each	
2-0=lineal feet.....	<u>32-0</u>
11"×6" polished projected sills to windows hewn on	
inner edge.....33 each 4-0=	<u>132-0</u>

12"×9" polished checked lintels	lineal feet	<u>33-0</u>
12"×9" polished checked lintels hewn on inner edge	31 each 4-0=	136-0
12"×9" polished checked semi-circled arched lintels over upper stair windows	5 each 10-0=	<u>50-0</u>

Chimney Stalks, Skews, etc.

Polished ashlar chimney stalk on north gable, girded	36-0×10-0	
Polished ashlar chimney stalk on south gable	31-0×11-0	
Polished ashlar chimney stalk on inner gables	6 each 35-0×11-0	
	Superficial feet	<u> </u>
4½" brick brigs	lineal feet	<u>123-0</u>
Labor working splay on ashlar	lineal feet	<u>108-0</u>
Labor working 56 peended stop ends of splay		
Labor working astragal moulding on ashlar including for extra size of stone	lineal feet	<u>163-0</u>
Labor working 28 miters on astragal moulding		
10"×6" polished moulded plinth, girding 12", including laying	lineal feet	<u>198-0</u>
25 miters of moulded plinth		
24"×10" polished moulded stone copes including hewing and building	lineal feet	<u>70-0</u>
Polished moulded hewing 10 return ends		
Labor cutting vents through cope	lineal feet	<u>10-0</u>
Labor socketing copes for 50 chimney pots		
12"×6" polished moulded and beveled label moulding, girding 11"	lineal feet	<u>50-0</u>
12"×6" polished moulded and beveled label moulding, circular	lineal feet	<u>6-0</u>
1 polished projecting stone panel 7' broad and 8'6" high, per estimate		
Carving on projecting stone panel, per estimate		
9 polished and moulded stone trusses, per estimate		
8 polished and moulded steps per estimate		
2 polished and moulded terminals per estimate		
24 dabbled crow steps average 15"×12" and 21" long having ½" droved margin all round, per estimate		
3 dabbled crow steps average 15"×12" and 33" long having ½" droved margin all round, per estimate		

6 dabbled corbels each 15"×12" and 30" long, per estimate	
3 polished ornamental finials each 12" square at base and 39" high in all, per estimate.....	
12"×6" polished plain skewes on main gables .lineal feet	80-0
9"×6" polished plain skewes on sidewalls of wings, lineal feet	25-0
6 polished club skewes on main gables.....	
6 polished club skewes on sidewalls of wings.....	
Extra for 9"×6" stone skewes of wings being knee'd on top and hollowed on underside	

Chimney Jambs, Vents and Hearths

16 set hammer dressed covins and lintels for room fire-places, per estimate	
30 pair polished kitchen chimney jambs	
30 polished lintels each 12"×10" and 4' long.....	
4½" 16 brick trimmer arches under room hearths	
25 brick trimmer arches under kitchen hearths	
9" fire clay vent linings	lineal feet
2½" polished Arbroath hearths in rooms 36 each 4-6×1-6	80-0
2½" polished Arbroath hearths in rooms 36 each 3-6×1-0	
2½" polished Arbroath hearths in kitchens, 30 each.....	4-6×1-3
2½" polished Arbroath hearths in kitchens, 30 each.....	3-6×1-0
	Superficial feet

Stairs and Pavement

3" polished Arbroath platts in shop doors, 3 each.....	4-6×3-0=
3" polished Arbroath platts on shop doors, 5 each.....	4-6×2-6=
3" polished Arbroath platts in shop doors, 6 each.....	4-6×2-0=
3" polished Arbroath platts in shop doors, 9 each.....	4-6×3-0=
	Superficial feet
Labor working polished chamfered edge of platts, lineal feet.....	94-6
24 polished moulded Arbroath steps of stairs, per estimate	

12 polished wheeling Arbroath steps of stairs, per estimate	
108 polished moulded Arbroath steps, per estimate	
27 polished moulded Arbroath steps, each 1'-6" long, per estimate	
10" polished parpend dados of shop windows, 6 each	3-0×1-6=
10" polished parpend dados of shop windows, 6 each	6-0×1-6=
10" polished parpend dados of shop windows, 6 each	2-6×1-0=
10" polished parpend dados of shop windows, 7 each	3-8×1-0=
10" polished parpend dados of shop windows, 6 each	2-6×1-6=
10" polished parpend dados in sidelights, 21 each	6-0×1-6=
	Superficial feet
Labor cutting dados to slope of groundlineal feet	72-0
Labor cutting and forming miters at 12 angles	
1 coa. finished asphalte paving having 4" bottoming of freestone shivers	60-0×4-6=
1 coat finished asphalte paving having 4" bottoming of freestone shivers	35-0×5-0=
1 coat finished asphalte paving having 4" bottoming of freestone shivers	28-0×6-0=
1 coat finished asphalte paving having 4" bottoming of freestone shivers	37-0×1-6=
	Superficial yards
12"×8" new dressed whinstone borderlineal feet	150-0
Paving front footpath of street	150-0×12-0
Paving front footpath of street	170-0×10-6
Paving front footpath of street	85-0×10-0
Paving in back courts	105-0×30-0
Paving in back courts	54-0×25-0
	Superficial yards
Paving in water closets30 each 6-0×4-6
Paving in lavatories30 each 7-0×4-0
Paving in sculleries30 each 7-0×3-0
Paving on stair landings18 each 9-0×4-0
Paving in closses6 each 15-0×4-0
Paving in closses6 each 9-0×4-0
	Superficial yards

Paving 4" thick on roof of ashpit	12-0×9-0	12-0-0
Labor forming gutters in paving.....	lineal feet	230-0
Labor forming 6 basins in paving		
Labor forming moulded edges of stair landings, lineal feet		140-0
2" second class Caithness pavement jointed		
with Portland cement covering drains	160-0×4-6	
Cutting raggles 1½"×1" in brick walls for concrete paving	lineal feet	470-0

Iron and Steel Works

6 cast iron double columns of shop front.....	cwts	114-0-0
Cast iron L and I beams	hundredweights	86-0-0
Cast iron box beams.....	hundredweights	25-0-0
9 cast iron circular pillars	hundredweights	126-0-0
12"×5" rolled steel beams weighing 42 lbs. per lineal foot, in lengths about 17'	lineal feet	97-0
10"×6" rolled steel beams weighing 48 lbs. per foot in lengths about 15½'	lineal feet	93-0
10"×6" rolled steel beams weighing 42 lbs. per lineal foot, in lengths about 17'	lineal feet	200-0
10"×5" rolled steel beams weighing 28 lbs. per lineal foot, in lengths from 7 to 11'	lineal feet	440-0
8"×6" rolled steel beams weighing 33 lbs. per lineal foot, in lengths from 11 to 15'	lineal feet	154-0
6"×5" rolled steel beams weighing 23½ lbs. per lineal foot	lineal feet	8-0
5½"×4¼" rolled steel beams weighing 18 lbs. per lineal foot, in lengths under 10'	lineal feet	84-0
5"×3" rolled steel beams weighing 10 lbs. per lineal foot, in 7'0" lengths	lineal feet	60-0
6"×6" ½" rolled steel Tees in 10½' lengths.....	lineal feet	120-0
3"×3" ⅜" rolled steel Tees in 7' lengths.....	lineal feet	14-0
5"×4½" rolled iron beams weighing 23 lbs. per lineal foot.....	lineal feet	300-0
1"×3" rolled iron beams weighing 12 lbs. per lineal foot, lineal feet.....		240-0
Labor raising and laying rolled steel beams	lineal feet	300-0
Labor raising and laying rolled steel beams, weighing 48 lbs. per lineal foot	lineal feet	90-0
Laboring raising and laying rolled steel beams weighing 33 lbs. per lineal foot	lineal feet	150-0

Labor raising and laying rolled steel beams weighing 28 lbs. per lineal foot.....lineal feet	440-0
Labor raising and laying rolled steel beams weighing 23½ lbs. per lineal footlineal feet	8-0
Labor raising and laying rolled steel beams, weighing 18 lbs. per footlineal feet	86-0
Labor raising and laying rolled steel beams, weighing 10 lbs. per lineal footlineal feet	60-0
Labor raising and laying rolled steel beams 6"×6"×½" teeslineal feet	120-0
Labor raising and laying rolled steel beams 3"×3"×⅜" teesper lineal feet	1-0
Labor raising and laying rolled iron beams weighing 23 lbs. per footlineal feet	300-0
Labor raising and laying rolled steel beams, weighing 12 lbs. per footlineal feet	240-0
4" machine Arbroath coddings under beams, 6 each 2-0×1- 0	
4" machine Arbroath coddings under beams, 3 each 2-0×0-10	
4" machine Arbroath coddings under beams, 2 each 2-0×0- 9	
Superficial feet	=====
7/8" malleable iron circular stancheons of ground flat windows.....60 each 8-0 lineal feet	480-0
2½"×½" malleable flat cross bars perforated for stancheons.....lineal feet	45-0
6 iron clothes poles, per estimate.....	-----

ESTIMATE FOR CARPENTER AND JOINER WORKS

Scaffolding, etc.

Furnishing all necessary scaffolding, planks and tresses, putting up gangways and supports, mason's shed and tool house, making moulds of strong zinc, blinding openings, including hinged doors with locks, covering projections of masonry with rough boarding, and inclosing building with proper barricade having the necessary gates, footpath and hand-rail in accordance with police regulations.....

Furnishing rough platform about 10' square with bearers and sides for mixing cement.....

Fitting up temporary office for clerk of works 10' square inside (the brick walls are built by mason) having wood floor and roof, glazed window with hinged shutter, door with hinges and lock, plain table with drawer and stool, the price to include for covering roof with slates complete.....

Centers, Safelintels, etc.

Centers and supports for 3 semi-circular arches of openings in 9" brick wall each 3' span daylight....	
Centers and supports for 45 brick trimmer arches under hearths 4 to 4½' long.....	204-0
4"×2" beveled springers for brick trimmer arches, lin. ft.	
1" sawn boarding with rough bearers and supports under concrete floors of water closets and stair landing, etc., also for roof of ashpit (to be afterwards removed)..... superficial yards	157-0
Safe lintels over openings (sawn on one side and edge) cubic feet.....	220-0
4½"×4" cleaned safe lintels over windows in water closets, lineal feet.....	72-0
9"×6" sawn beams under roof including dovetailing for and inserting ceiling joists..... lineal feet	63-0
6"×3" cleaned beaded beams over bed opens.. lineal feet	216-0

Assisting masons in setting up, also racking 6 cast iron double columns each 12' high of shop front	
Assisting masons in setting up 9 circular cast iron pillars from 12' to 13' high	
6"×1" wall plates under sleepers.....lineal feet	<u>207-0</u>
9"×1" wall plates under sleepers.....lineal feet	<u>234-0</u>
9"×1" wall plates under joists.....lineal feet	<u>798-0</u>
10"×1½" wall plates under roof.....lineal feet	<u>230-0</u>
6"×1½" wall plates under roof.....lineal feet	<u>123-0</u>
1½"×1½" runners on brick bearing partitions...lin. ft.	<u>618-0</u>
456 dooks each 9"×4½"×3¼" for fixing door frames in brick partitions	
6½"×2½" sleepers of first quality red dram battens, placed 18" to centers, in ground floorlineal feet	<u>2427-0</u>
10"×2¼" joisting of first quality pitch pine in 36½' lengths.....lineal feet	<u>6570-0</u>
10"×2¼" joisting of first quality pitch pine in 20½' lengths and under	<u>1377-0</u>
Extra for joisting being 10"×3" instead of 10"×2¼" to carry bridles at hearths	<u>990-0</u>
Labor checking joists on to tees over oriels.....lineal feet	<u>216-0</u>
10"×3" bridles at hearths, dovetailed for joists, lineal feet	<u>216-0</u>
10"×1½" slip joists at partitions.....lineal feet	<u>486-0</u>
90 cast iron shods for ends of bridles.....	
10"×2" solid dwangs between joists.....lineal feet	<u>684-0</u>

Roofing

6½"×2½" ceiling joists of first quality white dram battens, placed 18" to centers.....lineal feet	<u>3132-0</u>
White dram roof spars 6½"×2½" placed 18" to center, superficial yards	<u>590-0-0</u>
White dram roof spars 6"×2" placed 18" to center, superficial yards	<u>60-0-0</u>
11"×1½" ridgeboards, rounded on top	<u>176-0</u>
11"×1½" piend rafters, rounded on top, including cutting and fitting spars on each side.....lineal feet	<u>168-0</u>
6"×1" flank plates including cutting and fitting sarking at one side	<u>150-0</u>
5"×2" Barks and osterpieces of white dram battens placed 18" to center, half checked and well nailed at ends.....lineal feet	<u>2808-0</u>

5/8" half checked white pine sarking in not more than 9" breadths	superficial yards	630-0-0
Cutting and fitting sarking at piers	lineal feet	168-0
Cutting and fitting sarking at angled skewes	lineal feet	50-0
6" x 7/8" rough facing for fixing iron gutters	lineal feet	111
Doubling fillets at eaves and skewes	lineal feet	518-0
3/4" x 3 hatchboards each 27" x 16" in ceilings having bars on back, bridles, checks, T hinges and long press lock complete		
3 cast iron hinged rooflights each 16" x 36" daylight, with quadrant fastener and glazed with 3/16" patent rolled plate glass complete		
5/8" rough boarding on ceiling joists	superficial yards	12-0-0
4" x 2" rough framing of ladders	lineal feet	32-0
11" x 1 1/4" cleaned trap ladders on outside of roof, painted 3 coats oil paint all round	lineal feet	123-0
120 chamfered fillets each 2" x 1 1/2" and 11" long, painted 3 coats oil paint all round		
12 galvanized iron straps each 1 1/4" x 3/16" and 12" long, bent to fit round ridges and fixed with screws		

Deafening Boarding Flooring, etc.

5/8" deafening boarding of red pine in narrow breadths with fillets 1 1/2" x 3/4" of upper floors, superficial yards	1250-0-0
36 blocks each 16" x 8" x 2" fitted between joists for gasaliers	
Bracketing for lath inclosing steel beams	superficial feet 102-0-0
Red pine straps 1 1/2" x 3/4" and 12" to centers fixed to well dried redwood dooks 20" apart on outside walls, superficial feet	631-0-0
1 1/3" white dram flooring in 6" breadths tongued and grooved and well nailed with two nails to each board into every joist and carefully cleaned off after finishing, price to include for bearers at windows and press bossings, etc.	superficial feet 1695-0-0
Angle cutting on flooring	lineal feet 105-0
Labor cutting and fitting flooring neatly at 9 circular iron pillars	
Labor cutting and fitting flooring neatly at 37 circled corners of breasts	
Borders of flooring mitered round 51 hearths	

Cast iron ornamental 10-lb. baluster railing of stairs to engineer's selection, with thin iron strap at top, including cutting and fitting up	lineal feet	<u>42-0</u>
Extra for 3 main balusters of stairs		
3"×21½" moulded Spanish mahogany cope (French polished)	lineal feet	<u>43-0</u>

Windows with Their Finishings

51 windows in back wall having cases with 1" sills, 1½" lintel, 1" pulley stiles and 7½" inside facings, 5" outside facings, batten rods and parting beads, and 2" sashes with astragals where required, double hung on 1¾" strong brass faced axle pulleys, best Italian hemp cord and cast iron weights, primed and glazed with 22 oz. sheet glass and afterwards painted 2 coats oil paint on outside	superficial feet	<u>1230-0</u>
9 windows in front wall, each in two compartments and having cases with 4" sills, 1½" lintel, 1" pulley stiles, and 7½" inside facings 5" outside facings, batten rods and parting beads and 2" sashes with astragals where required, double hung on 1¾" strong brass faced axle pulleys, best Italian hemp cord and cast iron weights, primed and glazed with 22 oz. sheet glass and afterwards painted 2 coats oil paint on outside	superficial feet	<u>360-0</u>
18 oriel windows each in three compartments and having cases with 4" sills, 1½" lintel, 1" pulley stiles and 7½" inside facings, 5½" outside facings, batten rods and parting beads and 2" sashes with astragals where required, double hung on 1¾" strong brass faced axle pulleys, best Italian hemp cord and cast iron weights, primed and glazed with 22 oz. sheet glass and afterwards painted 2 coats oil paint on outside superficial feet		<u>986-0</u>
144 moulded ends of stiles of upper sashes of front windows		
6 hinged sashes each 18"×36", daylight having 4½" frame, with beveled checked sill, beaded checks, 3" strong brass hinges, brass knob and button and glazed with 1¼" rough cast plate glass complete		

18 hinged sashes each 18" x 60" daylight having 4½" frame, with beveled checked sill, beaded checks, 3" strong brass hinges, brass knob and button and glazed with ¼" rough cast plate glass complete.	
9 staircase windows, double hung and same as described for back windows, also including extra for border panes, and clear glass in center, and colored border, superficial feet	<u>220-0</u>
3 teak wood louverboarded semi circular arched tops of upper staircase windows each 3' span including circled framing etc. complete.	
1¾" bound shutters with flush planted mouldings, and 7/8" plain closers having morticed close ends, to windows in ground floor. superficial feet	180-0
1¼" bound lining with flush planted mouldings in rooms, also mock shutters in kitchens. . superficial feet	1200-0
5/8" cleaned boarding on soffits superficial feet	165-0
5/8" chamfered selected white pine lining in 3" breadth, with grounds, on breasts and elbows of windows in kitchens, also sides and soffits of scullery windows and enclosing sinks superficial yards	130-0-0
5/8" beaded cope. lineal feet	<u>230-0</u>
Extra for forming recesses under 27 sinks with lining round ingoing and bead on angles.	
Extra for forming 27 screwed opening boards in sinks with bars	
27 strong framed supports under sinks.	
27 teak blocks each 16" x 9" x 1½" perforated for cranes. .	
4" x 1" teak cope lineal feet	<u>63-0</u>
2" x 1" teak cope lineal feet	<u>63-0</u>
1" teak sole board with bearers. superficial feet	<u>108-0</u>
3" x 7½" beaded cope over oriels lineal feet	<u>198-0</u>
9½" x 3¼" dressed soleboard, with bearers bottled on edge of oriels (if required) lineal feet	<u>198-0</u>
1½" x 7/8" cleaned grounds, with dooks, for staffbeads, lineal feet.	360-0
1½" turned staffbeads lineal feet	<u>321-0</u>
36 turned moulded bases to staff beads each 3" diameter and 8" high	
36 turned moulded capitals each 5" high.	
1¼" quarter beads on edges of shutters lineal feet	237-0
¾" beads in angles of cases. lineal feet	<u>237-0</u>

6½"×5½" moulded facings and groundslineal feet	896-0
1½"×5½" moulded facings and groundslineal feet	<u>432-0</u>
Grounds only for facingslineal feet	<u>83-0</u>
36 pair plain base blocks to facings	
Putting ironmongery on 27 windows	
Putting ironmongery on 18 windows with mock shutters	
Putting ironmongery on 9 windows each in two compartments with mock shutters	
Putting iron mongery on 18 oriel windows each in three compartments with mock shutters.....	
Putting ironmongery on 6 windows with shutters	
120 strong brass spring sash fasteners and screws	
210 strong brass ring sash lifters and screws	
66 brass shutter knobs and shields	
36 ebony shutter knobs and shields	
12 pair 3" edge hinges and screws.....	
12 pair 1½" backfold hinges and screws	
6 iron shutter bars each 18" long with keepers and screws	
7"×3½" moulded sills of shop windows and sidelights, lineal feet.....	<u>106-0</u>
3"×2½" moulded and checked framing of shop windows and sidelights.....lineal feet	<u>447-0</u>
3"×3" double moulded and checked angular framing, lineal feet.....	<u>120-0</u>
2"×7½" beaded coping	<u>219-0</u>
8"×¾" teak fret facing for ventilation.....lineal feet	<u>106-0</u>
14" best polished British plate glass in shop windows, in panes containing from 45 to 50 superficial feet, including glazing	<u>592-0</u>
14" best polished British plate glass in sidelights, in panes containing about 23 superficial feet, superficial feet	<u>270-0</u>
13½" framed stop chamfered dwarf shutters with open panels and planted beads for wire work, superficial feet	<u>351-0</u>
3"×2" moulded and checked top rail for shutters, lineal feet.....	96-0
Labor working 36 mitered return ends of top rail	
Galvanized wire netting, including fitting in, superficial ft.	296-0
Putting ironmongery on 12 shop windows with shutters	
Putting ironmongery on shutters in lower part of 6 shop doors.....	

144 iron corner clasps and screws for edge of shutters and end of top rail	
18 iron corner clasps and screws with checked plates for edge of shutters and end of top rail	
Iron strap $1\frac{1}{2}$ " broad, with screws	lineal feet 96-0
18 strong budget latches	
18 black American lifting-off handles and screws	
6" \times $1\frac{1}{2}$ " plain pilasters of shop front, dooked to iron columns	lineal feet 60-0
6 chamfered base blocks each 6" \times 2" and average 15" high	
6 moulded capitals each 9" \times 3" and 12" high	
$\frac{7}{8}$ " cleaned boarding of frieze, 20" broad, in one breadth, with straps and dooks	superficial feet 187-0
4" \times 2" moulded architrave under frieze	lineal feet 112-0

Doors with Their Frames and Finishings

5" \times 2" cleaned frames for porch doors in shops	lineal feet 162-0
6 $\frac{1}{4}$ " \times 2" 3 pair frames to doors in $1\frac{1}{2}$ " brick partitions, the ceilings 12' high, having fixtures at top and bottom	
6 $\frac{1}{4}$ " \times 2" 27 pair frames to doors in $1\frac{1}{2}$ " brick partitions, the ceilings from 10' to 10'3" high, having fixtures at top and bottom	
6 $\frac{1}{4}$ " \times 2" 36 pair frames to doors in $1\frac{1}{2}$ " brick partitions, the ceilings 12' high, having double lintel for tanking it	
3 $\frac{1}{2}$ " \times $1\frac{1}{2}$ " 45 pair frames to wallpress doors	
6" \times 2" cleaned frames for inside doors at small houses, lineal feet	155-0
5 $\frac{1}{4}$ " \times 2" cleaned frames for doors to water-closets, lavatories and sculleries	lineal feet 810-0
4 $\frac{1}{2}$ " \times 2 $\frac{1}{4}$ " cleaned frames for gates, dooked to brick, lineal feet	12-0
2" 6 bound two leaved porch doors in shops, having raised planted mouldings on both sides, and upper part made for glass	superficial feet 216-0
3" \times 2 $\frac{1}{4}$ " moulded and checked framing of fanlights, with planted glass checks	lineal feet 73-0
$\frac{1}{4}$ " best British polished plate glass in panes containing from 6 to 8 superficial feet, including glazing, superficial feet	99-0
1 $\frac{3}{4}$ " 18 bound entrance doors having flush planted mouldings on both sides	superficial feet 378-0

1 $\frac{3}{4}$ " 9 bound two-leaved doors having flush planted mouldings on both sides superficial feet	189-0
1 $\frac{5}{8}$ " 45 bound pass doors having flush mouldings both sides superficial feet	915-0
1 $\frac{5}{8}$ " 72 bound press, closet, scullery and lavatory doors, having flush mouldings on face, and square framed on back. superficial feet	1128-0
17 $\frac{8}{8}$ " 24 framed and lined doors to water closets, having 7 $\frac{8}{8}$ " narrow chamfered lining and stop chamfered framing (red pine). superficial feet	420-0
2" 3 framed and lined gates, having 7 $\frac{8}{8}$ " chamfered lining and upper part left open for iron stanchions (red pine) superficial feet	63-0
6" x 2" cleaned frames for borrowed lights . . . lineal feet	4-0
2" fixed borrowed lights, glazed with $\frac{1}{4}$ " rough cast plate glass superficial feet	27-0
2" fixed fanlights glazed with 21 oz. picked sheet glass, superficial feet	216-0
Labor working beaded and checked edges of two-leaved doors lineal feet	234-0
5 $\frac{8}{8}$ " beaded checks lineal feet	2380-0
Fillet checks lineal feet	100-0
6" x 5 $\frac{8}{8}$ " beaded checks round in going of small openings in 4 $\frac{1}{2}$ " partitions at ends of beds. lineal feet	72-0
1 $\frac{1}{2}$ " x 1 $\frac{1}{4}$ " rounded berges at entrance doors (white pine). lineal feet	81-0
1" x 1 $\frac{1}{4}$ " rounded berges at inner doors to small houses (white pine). lineal feet	27-0
5 $\frac{8}{8}$ " white pine lining, chamfered in joints, with grounds, sides and soffits of inner doors, superficial yards.	20-0-0
1 $\frac{1}{2}$ " x 3 $\frac{1}{4}$ " moulded facings in rooms, lobbies and stairs, lineal feet	3000-0
1" x 5 $\frac{8}{8}$ " moulded facings in kitchens, sculleries, closets and shops lineal feet	2400-0
270 pair plain base blocks for facings	
3 $\frac{1}{4}$ " double beaded transom facings. lineal feet	132-0
5 $\frac{8}{8}$ " double beaded transom facings. lineal feet	132-0
Labor fitting and hanging 162 doors	
Labor fitting and hanging 15 two-leaved doors	
Putting ironmongery on 162 doors	
Putting ironmongery on 15 two-leaved doors	

Putting ironmongery on 6 fanlights.....	
54 pair 7" hinges and screws.....	
72 pair 6" hinges and screws.....	
72 pair 5" hinges and screws.....	
6-12"×1½" patent brass flush slip bolts with keepers and screws.....	
6-36"×1½" patent brass flush slip bolts with keepers and screws.....	
6-4" mortice lever locks having ebony and bronzed crank handles on both sides.....	
36-8" rim locks with check box and 2½" milled edge brass mounting inside and iron octagonal handle outside.....	
18-6" mortice locks with Mace's patent ebony mounting one side and brass mounting other.....	
18 strong spring kitchen latches with Mace's patent brass mounting both sides.....	
30-4½" rim latches with Mace's patent brass mounting both sides.....	
63-5" press locks.....	
45 set Mace's patent brass mock mortice mounting....	
18 set Mace's ebony mock mortice mounting.....	
3-6' galvanized locks for gates having japanned octagonal pull knobs both sides.....	
18-12" patent spring flush slip bolts with keepers and screws.....	
6 pair strong brass pivot hinges and screws for fanlights	
6 strong cords with brass eyes and yacht hooks for fanlights.....	
7½" malleable iron stancheons at gates and borrowed lights in back closes, including lead batting and putting in.....	

Skirtings, Etc.

6½"×¾" moulded skirtings and grounds in rooms and lobbies.....lineal feet	1200-0
6"×¾" moulded skirtings and grounds in kitchens, sculleries and closets.....lineal feet	1640-0
600 miters of moulded skirtings.....	
63 rounded corners of moulded skirtings.....	
4½"×¾" moulded utensil belting with dooks, lineal feet	200-0
6"×¾" double moulded hat belting.....lineal feet	108-0

1 $\frac{1}{4}$ " corner beads with hooks on angleslineal feet	726-0
8" \times 1 $\frac{1}{2}$ " cleaned shelves with hooks at kitchen fireplaces, lineal feet	200-0

Kitcher Fittings, Beds and Presses.

7 $\frac{1}{8}$ " shelving fitted in kitchen cabinetssuperficial feet	1120-0
Labor working 66 rounded corners of shelves	
122 strong framed iron brackets under shelves	
1 $\frac{1}{2}$ " cleaned fir tops of dressers and bunkers each in one breadthsuperficial feet	378-0
7" \times 7 $\frac{1}{8}$ " moulded skirtinglineal feet	243-0
Labor working 54 moulded return ends of moulded skirting	
5 $\frac{3}{8}$ " dovetailed drawers with 7 $\frac{1}{8}$ " fronts, glue blocked, superficial feet	318-0
1 $\frac{1}{2}$ " bound doors with flush planted mouldings, superficial feet	231-0
3" \times 1 $\frac{1}{2}$ " cleaned framinglineal feet	972-0
6" \times 1 $\frac{1}{2}$ " cleaned framinglineal feet	108-0
Fillets and sliders for 54 drawers	
7 $\frac{1}{8}$ " sparrd shelves 1" apartsuperficial feet	216-0
3" \times 7 $\frac{1}{8}$ " bars on back of sparrd shelves 1" apart, lineal feet	216-0
7 $\frac{1}{8}$ " plain shelvessuperficial feet	162-0
1 $\frac{1}{8}$ " rough bottoms of coal boxessuperficial yards	18-0-0
1 $\frac{1}{8}$ " batten lining, tongued, grooved, dressed and chamfered where exposedsuperficial yards	90-0-0
3" \times 3" rounded and chamfered corner posts, lineal feet	324-0
1" corner beads on anglelineal feet	81-0
Extra for forming hinged parts of front and top of 27 coal boxes, with bars on back having screws	
54 pair 2" strong backfold hinges and screws	
27 Japanned iron strong hooks and eyes on plates and screws	
Labor fitting and hanging 27 small two leaved doors . . .	
Putting ironmongery on 27 dressers and coal boxes . . .	
54 pair 3" edge hinges and screws	
1 $\frac{1}{4}$ " 27 brass turnbuckles	
27 strong hooks and eyes on plates and screws	
51 black drawer cup handles and screws	
3" \times 2" cleaned framing forming bed closets . .lineal feet	135-0
3" \times 2" cleaned framing forming bed closets grooved for lininglineal feet	630-0

2 $\frac{3}{4}$ " \times 2" cleaned and stop chamfered framing at openings.....lineal feet	255-0
1 $\frac{1}{8}$ " pitch pine lining, tongued, grooved and beaded or chamfered in joints.....superficial yards	105-0-0
$\frac{5}{8}$ " beaded checks.....lineal feet	306-0
1" \times 7 $\frac{1}{8}$ " beaded cope.....lineal feet	135-0
$\frac{5}{8}$ " moulding under beaded cope.....	135-0
1 $\frac{1}{4}$ " \times 1 $\frac{1}{4}$ " 18 malleable iron angle pieces each 14" long at junctions of copes and standards, fixed with screws..	
3" galvanized iron curtain rods having bent palm ends and fixed with screws.....lineal feet	54-0
9 dozen galvanized iron rings 1 $\frac{1}{4}$ " diameter on curtain rods.....	
$\frac{5}{8}$ " narrow chamfered white pine lining backs of room presses.....superficial yards	42-0-0
7 $\frac{3}{8}$ " cleaned white pine boarding on ingoing.... sup. ft.	306-0
7 $\frac{3}{8}$ " cleaned white pine shelving..... superficial feet	216-0
Labor cutting raggles for shelving.....lineal feet	114-0
$\frac{5}{8}$ " beaded slips.....lineal feet	306-0
5" \times $\frac{5}{8}$ " chamfered skirting..... lineal feet	54-0

Lavatory and Water-Closet Fittings

24 French polished birch water-closet seats each about 18" square and 1 $\frac{1}{2}$ " thick, in two thicknesses, shaped and beaded on edge and having aperture complete...	
24 French polished birch hinging rails, each 4" \times 1 $\frac{1}{2}$ " and 33" long with two moulded brackets underneath	
24 pair 3" brass edge hinges and screws.....	
96 India rubber studs each 1" diameter with brass sockets, plates and screws and fitting in.....	
$\frac{5}{8}$ " angle pipe covers from 6" to 9" broad, with grounds and fixed with brass sockets and screws...lineal feet	72-0
Two sided pipe covers girding 8" to 12" broad, with grounds and fixed with brass sockets and screws, lineal feet.....	150-0
6" \times $\frac{5}{8}$ " cleaned pipe covers with beaded checked grounds on both sides and fixed with brass sockets and screws.....lineal feet	60-0

Shop Fittings

5/8" chamfered selected white pine lining in 3" breadths, hand planed, with grounds 1 1/2" x 1" and not more than 30" apart, and well dried dooks on lower walls of shops, also sides and soffits of windows, doors, etc.....	superficial yards	622-0-0
4" x 2" white pine dwangs for lining of shops (for extra value over grounds)	lineal feet	162-0
5/8" beaded cope at top of lining.....	lineal feet	500-0
Labor working bead on angles of lining.....	lineal feet	230-0
6" x 5/8" double beaded facings with dooks ...	lineal feet	156-0
4" x 2" white pine bearers under soleboards in windows lineal feet.....		254-0
1 1/8" batten soleboards.....	superficial yards	12-0-0
5/8" narrow chamfered lining only of breasts of batten soleboards	superficial yards	12-0-0
Extra for forming 12 small doors in soleboards with bars on back and putting on ironmongery		
12 pair 1 1/2" backfold hinges and screws.....		
12 brass knobs		
12 black buttons.....		
Labor working bottle on edge of soleboards.....	lineal feet	72-0
1 1/4" shelving fitted up where directed.....	superficial feet	302-0
1" shelving fitted up where directed.....	superficial feet	490-0
7/8" shelving fitted up where directed.....	superficial feet	1360-0
3" x 1 1/2" beaded grounds, dooked to wall	lineal feet	480-0
2" turned beads on fronts of shelves.....	lineal feet	360-0
60 turned moulded bases each 1 1/2" diameter and 3 1/2" high		
60 turned moulded capitals each 6" diameter and 4 1/2" high		
5/8" plain soffit of cornice with bearers ...	superficial feet	450-0
6" x 5" moulded cornice having plain frieze 12" deep in all with blockings	lineal feet	450-0
24 miters of moulded cornice.....		
1 1/2" bound doors with flush planted mouldings to small presses	superficial feet	378-0
Labor fitting and hanging 42 small two-leaved doors ...		
Labor working beaded and checked edges.....	lineal feet	190-0
Labor working thumb moulding on edge of top.....		
.....	lineal feet	390-0
84 pair 3" edge hinges and screws.....		
42 strong iron hooks and eyes on plates and screws ...		

42 large size latches	
Putting ironmongery on 42 small two-leaved doors.....	
7/8" mahogany tops of counters (French polished), superficial feet	260-0
1 1/4" X 7/8" mahogany thumb moulding, grooved on edge (French polished)	133-
12 miters of mahogany thumb moulding	
1 3/8" bound fronts with raised planted mouldings on face, superficial feet	360-0
3" yellow pine lining in 3" breadths, tongued, grooved and chamfered in joints on ends.....	8 0 0
8" moulded base with blockings.....	133-0
12 miters of moulded base	
3" X 2" moulding under top.....	133-0
12 miters of moulding	
6" X 8" cleaned pilasters	90 0
Extra for mitring and returning moulded base at 30 cleaned pilasters	
Extra for mitring 3" X 2" moulding at 30 cleaned pilasters	
5/8" dovetailed drawers with 7/8" fronts (glue blocked), superficial feet	380-0
3" X 1 1/2" cleaned framing and posts	1400-0
Fillets and sliders for 51 drawers	
6 hardwood blocks having four cash cups turned in each	
Executing all jobbings required by plumbers, gasfitters, and other tradesmen, including all rough material required for cranks in roof, etc., also sweeping out floors, and removing rubbish to outside, this rubbish will be then removed by contractor for mason work	
Maintaining carpenter, joiner, glazier and ironmongery works in perfect condition during the progress of the work, making good from time to time any damaged or imperfect work from whatever cause arising from theft, storm, fire, tradesmen's operations, accidents of every kind, malicious damage or other- wise, and after the several tradesmen finish, overhau- ling the work, and repairing where necessary, so that the carpenter, joiner, glazier and ironmongery works may be in such a perfect condition that the necessary formal written certificate of completion may be granted by the engineer	

Conditions

The safelintels, beams, wall plates, wall straps, dooks, window sashes and cases, frames and framing of outer doors and shop windows and shutters to be of Riga red pine, roofing of white pine, and all other timber unless where otherwise mentioned to be of American yellow pine. The whole timber to be of first quality and thoroughly seasoned, and free from sapwood shakes, large or loose knots or other blemishes, the finishings to be specially selected entirely free from blemish, and to stand the full sizes specified when finished.

The work to be framed and fitted in the most approved manner, the whole of the nails used throughout to be steel nails, cut or patent wrought as the engineer may decide.

The whole materials to be of the very best quality and the work done in the most complete and tradesmanlike manner, to the entire satisfaction and directions of the proprietor and engineer, or any person appointed as inspector, who shall at all times be entitled to examine the work, and to reject, or cause to be rejected, all bad or defective materials or workmanship, but such examination shall in no way diminish, affect or impair the obligations of the contractor, as regards the due and proper execution of the work in all respects.

The proprietor reserves full power to make alterations on the plans or mode of executing the work, and to increase, lessen or altogether omit such portions of the work as may be thought proper.

The work will be measured when finished, and whether more or less than now estimated, will be valued at the rates contained in this estimate or others in strict proportion thereto, and in proportion to the slump sum of the tender.

The prices for extra work to which schedule rates do not apply, to be revised, and if necessary, corrected by the engineer.

The contractor to pay half expense of schedules and measurements.

The proprietor may not accept the lowest or any offer.

The contractor shall have the whole responsibility of maintaining and supporting his department of the work until the whole is satisfactorily completed and formally taken off his hands and shall be bound to rectify any failure from whatever cause arising, and to execute all works of whatever kinds necessary to complete this department of proposed works in accordance with

plans and foregoing particulars before the formal written certificate of completion be granted by the engineer.

Thomas Smith, Esq.

SIR:—I hereby offer to execute the carpenter and joiner works of the tenements and shops which you propose to erect in Fifth avenue, according to plans thereof by Mr. James Thomson, civil engineer, now shown, in conformity with and to the extent of the foregoing estimate for the sum of.

Your acceptance of this offer will be binding on

Your Obedient Servant.

FORM OF MEASUREMENT OF PLASTER WORK

Measurement of the plaster work of tenements and shops erected in Fifth avenue by Thomas Smith, Esq.

39-0	3 coats plaster on ceilings of rooms, south houses, three upper floors	3 ea. 10-0 × 9-6
23-0	3 coats plaster on ceilings of beds	3 ea. 6-0 × 5-6
35-0	3 coats plaster on ceilings of kitchens	3 ea. 9-0 × 8-6
14-0	3 coats plaster on ceilings of beds	3 ea. 6-0 × 4-0
17-0	3 coats plaster on ceilings of sculleries,	3 ea. 5-6 × 3-0
21-0	3 coats plaster on ceilings of lobbies,	3 ea. 8-0 × 4-0
	Except breaks 3 ea.	4-0 × 3-6
37-0	3 coats plaster on ceilings of rooms, north houses	3 ea. 9-6 × 9-0
23-0	3 coats plaster on ceilings of beds	3 ea. 6-0 × 5-6
33-0	3 coats plaster on ceilings of kitchens,	3 ea. 8-6 × 8-0
14-0	3 coats plaster on ceilings of beds	3 ea. 6-0 × 4-0
17-0	3 coats plaster on ceilings of sculleries,	3 ea. 5-6 × 3-0
23-0	3 coats plaster on ceilings of lobbies,	3 ea. 7-6 × 4-0
	Except 3 ea.	4-0 × 3-6
299-0	3 coats plaster on walls of above apartments, three upper floors	299-0 × 30-0
	Deduct 12 front windows	each 3-6 × 8-0
	14 back windows	each 3-6 × 7-6
	18 doorsides	each 3-0 × 7-0
	12 doorsides and fanlights	each 3-0 × 8-6
39-0	add on ceiling of room, south house, ground floor	10-0 × 9-6
23-0	add on ceiling of bed	6-0 × 5-6
35-0	add on ceiling of kitchen	9-0 × 8-6
14-0	add on ceiling of bed	6-0 × 4-0
17-0	add on ceiling of scullery	5-6 × 3-0
21-0	add on ceiling of lobby	8-0 × 4-0
	Except	4-0 × 3-6
37-0	add on ceiling of room, north house	9-6 × 9-0
23-0	add on ceiling of bed	6-0 × 5-6
33-0	add on ceiling of kitchen	8-6 × 8-0
14-0	add on ceiling of bed	6-0 × 4-0

17-0 add on ceiling of scullery.....	5-6× 3-0	
23-0 add on ceiling of lobby.....	7-6× 4-0	}
	Except 4-0× 3-6	
299-0 add walls of above apartments, ground floor	each 299-0×10-0	_____
Deduct 4 front windows	each 3-6× 8-0	
4 back windows	each 3-6× 7-6	
8 doorsides	each 3-0× 7-0	
4 doorsides and fanlights	each 3-0× 8-6	_____
Add ceiling of closs.....	29-0× 4-0	
Add ceiling of closs	12-0× 4-0	
Add upper walls above tile lining	64-0× 5-0	
Add ceiling of staircase	17-0× 9-0	
Add walls	52-0×43-0	_____
Deduct 8 doors and fanlights.....	each 3-0× 7-0	
3 staircase windows	each 4-0× 9-0	
2 closs opens	each 4-0× 9-0	_____
	Superficial yards	_____
7"×6" cornice of rooms in south houses, three upper floors.....	3 each 39-0=	117-0
7"×6" cornice of rooms in north houses, three upper floors	3 each 37-0=	111-0
7"×6" cornice in room, south house, ground flat..	39-0=	39-0
7"×6" cornice in room north house.....	37-0=	37-0
	Lineal feet	<u>304-0</u>
32 miters on cornice		
8 center flowers on ceilings each 3"6" diameter		
Relieving wood corner beads	lineal yards	<u>750-0-0</u>
Rounding plaster corners.....	lineal yards	<u>60-0-0</u>
Bedding 34 window cases in lime and pointing same with mastic and oil.....		
Mending broken plaster after the other tradesmen are finished		
Measured and calculated E. E. (signed) James Thompson C. E.		

FORM OF MEASUREMENT OF PLUMBER WORK

Measurement of the Plumber Work of Tenements and Shops erected in Fifth Avenue, by Mr. Thomas Smith.

7 lb. sheet lead lining gutters on roof.....3 each 20-0 x 2-0 = 120-0				
7 lb. sheet lead lining gutters on roof.....3 each 15-0 x 1-6 = 67-6 Cwts. Qrs. Lbs				
	Superficial feet 187-6	11	2	24
6 lb. sheet lead lining on ridge of roof.....40-0 x 1-6 = 60-0				
6 lb. sheet lead lining on piends of roof.....4 each 20-0 x 1-3 = 100-0				
6 lb. sheet lead lining on flanks.....2 each 30-0 x 1-6 = 90-0				
	Superficial feet 250-0	13	1	16
5 lb. sheet lead aprons at skews.....6 each 12-0 x 1-3 = 90-0				
5 lb. sheet lead aprons at skews.....2 each 14-0 x 1-3 = 35-0				
5 lb. sheet lead aprons at chimney stalks.....8 each 8-0 x 2-0 = 128-0				
5 lb. sheet lead aprons at chimney stalks.....16 each 3-0 x 2-0 = 96-0				
	Superficial feet 349-0	15	2	9
		40	2	21

To find the total weight of lead on roof multiply the superficial feet in each case by the pound per foot in margin, thus:—187.6 multiplied by 7 gives 1313.2.

Lead batts in raggles 1 1/4" longlineal feet 300-0
136 strong galvanized iron straps fixing lead on ridges
and piends

5"×4" cast iron moulded gutter along front eave, lineal feet	116-0
16 cast iron moulded close ends	
4 cast iron moulded drops or outlets	
12 heavy copper rose gratings in gutters at top of pipes	
3" bends from gutters made of 6 lb. lead. lineal feet	25 0
4½"×3½" cast iron semi round conductors, 3 ea. 40-0=	120 0
3 ea. 20-0=	60 0
Lineal feet	180 0
6 cast iron bends at bottom	
30 cast iron ornamental ears fixed with spikes	
6 cast iron ornamental cistern heads	
3' cast iron round conductors and waste pipes	
from jawboxes 6 each 30-0=	180-0
3 each 8 0=	24-0
3 each 6-0=	18-0
7 each 9-0=	63 0
9 each 4-0=	36-0
Lineal feet	321-0
9 cast iron single bends or shoes at bottom	
6 cast iron 3" ets at top	
22 cast iron branch pieces for waste pipes	
22 cast iron branch horns cast on for waste pipes	
4½" cast iron soil pipes from water-closets, 3 each 40-0	120-0
3 each 25-0	75-0
3 each 16-0=	48-0
Lineal feet	243-0
9 cast iron benches with heel rests at bottom	
24 cast iron horns for branches	
24 cast iron branch pieces	
4½" cast iron light air pipe ¼" metal above soil pipe	
6 each 10-0 lineal feet	60-0
6 cowls on top of air pipe as per drawing	
3" waste pipes made of 6 lb. lead lineal feet	91-0
5" lead branch soil pipes lineal feet	115-0
27 white enameled fire clay sinks each 27"×18"×10" outside measure	
3" 27 hydraulic drawn S traps of 7 lb. lead	
3½" 27 brass table washers with plug and chain	
¾" 27 heavy brass nose cocks	
27 lead collars connecting horns to lead waste pipes	
6 plain whiteware table top wash hand basins as per estimate	

Extra for 6 basins having brass pillar fount with flange.		
24 shanks, first quality "Citizen" flush down fire clay		
water-closets as per estimate.....		
24 collars made of 8 lb. l. " per estimate.....		
21 brass nipples each 5" diameter.....		
21 Doulton's patent iron improved three gallon vacuum		
siphon cisterns.....		
18 cast iron brackets including fitting up with screws...		
3/4" 21 brass knees with jam nut for overflow.....		
1 1/2" galvanized iron service pipes to water-		
closets.....	6 each 20.0=	120.0
	4 each 15.0=	60.0
	3 each 10.0=	30.0
	Lineal feet	210.0
Labor only forming 24 offsets on service pipes.....		
3/4" patent lead supply pipes 11 lbs. per lineal		
yard.....	6 each 30.0=	210.0
	6 each 25.0=	150.0
	6 each 15.0=	90.0
	Lineal feet	480.0
1/2" patent lead supply pipes 7 lbs. per lineal		
yard.....	7 each 30.0=	210.0
	6 each 20.0=	120.0
	4 each 15.0=	60.0
	3 each 17.0=	51.0
	Lineal feet	441.0
6 brass underground stop cocks on supply.....		
6 brass screwed ferrules.....		
3 cast iron stop cock cases.....		
3 cast iron horse shoe covers.....		
3/4" 3 brass cleansing cocks with coupling tails.....		
1 malleable iron stop cock key.....		

FORM OF MEASUREMENT OF TILE LININGS

Pure enameled cream 6" x 6" tiles on walls of classrooms	3 each 20-0 x 1-6 =	26-6-0
	3 each 15-0 x 1-6 =	22-1-6
	3 each 20-0 x 1-6 =	30-0-0
	Superficial yards	79-1-6
3" ornamental enameled border	linear feet	220-0
Enameled corner beads on angles	linear feet	40-0
9 enameled corner pieces of 3" ornamental border		
Cutting tiles at vertical and raking angles	linear feet	180-0
Extra for dark base 6" high	linear feet	200-0
Cutting and fitting tiles to moulded breasts of 36 steps		
Maintaining the tile linings in perfect condition during the progress of the work, etc., per estimate		

FORM OF MEASUREMENT OF PAINTER WORK

1 coat oil paint and size tinting ceilings of rooms, three upper floors—south houses, 3 each	10.0 × 9.6
1 coat oil paint and size tinting ceilings of beds, 3 each	6.0 × 5.6
1 coat oil paint and size tinting ceilings of kitchens	3 each 9.0 × 8.6
1 coat oil paint and size tinting ceilings of beds, 3 each	6.0 × 4.0
1 coat oil paint and size tinting ceilings of sculleries	3 each 5.6 × 3.0
1 coat oil paint and size tinting ceilings of lobbies	3 each 8.0 × 4.0 Except 3 each 4.0 × 3.6
1 coat oil paint and size tinting ceilings of rooms, north house	3 each 9.6 × 9.0
1 coat oil paint and size tinting ceilings of beds	3 each 6.0 × 5.6
1 coat oil paint and size tinting ceilings kitchens	3 each 8.6 × 8.0
1 coat oil paint and size tinting ceilings of beds	3 each 6.0 × 4.0
1 coat oil paint and size tinting ceilings of sculleries	3 each 5.6 × 3.0
1 coat oil paint and size tinting ceilings of lobbies	3 each 7.6 × 4.0 Except 3 each 4.0 × 3.6
1 coat oil paint and size tinting ceiling of room, south house, ground floor	10.0 × 9.6
1 coat oil paint and size tinting ceiling of bed ..	6.0 × 5.6
1 coat oil paint and size tinting ceiling of kitchen	9.0 × 8.6
1 coat oil paint and size tinting ceiling of bed ..	6.0 × 4.0
1 coat oil paint and size tinting ceiling of scullery	5.6 × 3.0
1 coat oil paint and size tinting ceiling of lobby, Except	8.0 × 4.0 } 4.0 × 3.6 }

1 coat oil paint and size tinting ceiling of room north house	9-6×9-0	
1 coat oil paint and size tinting ceiling of bed..	6-0×5-6	
1 coat oil paint and size tinting ceiling of kitchen	8-6×8-0	
1 coat oil paint and size tinting ceiling of bed..	6-0×4-0	
1 coat oil paint and size tinting ceiling of scullery	5-6×3-0	
1 coat oil paint and size tinting ceiling of lobby,	7-6×4-0	}
Except	4-0×3-6	
1 coat oil paint and size tinting ceiling of closs,	20-0×4-0	
1 coat oil paint and size tinting ceiling of closs,	12-0×4-0	
1 coat oil paint and size tinting ceiling of staircase	17-0×9-0	
	Superficial yards	=====
Size color on walls of apartments, three upper floors	200-0×30-0	
Size color on walls of apartments, ground floor	200-0×10-0	
Size color on walls of staircase.....	52-0×43-0	
Size color on upper walls above tile lining...	64-0× 5-0	
	Superficial yards	=====
3 coats oil paint in shades on plain cornices girding 20" lineal yards		<u>101-1-0</u>
3 coats oil paint in shades on 8 center flowers each 3'6" diameter		
3 coats oil paint in shades on 9 circular iron pillars each 12' high and girding 24" with stenciled ornaments		
Imitation rich dark oak with 3 coats ground and 1 coat varnish on woodwork, viz.:		
windows.....	12 each 10-0×8-0	
soffits of windows.....	12 each 8-0×2-0	
breasts and elbows.....	12 each 16-0×3-0	
doors, 26 sides.....	each 4-0×7-6	
doors and fanlights, 16 sides ..each	4-0×9-0	
	Superficial yards	=====
Imitation rich dark oak with 3 coats ground and 1 coat varnish on skirtings and beltings girding from 6" to 9".....	lineal yards	<u>420-0-0</u>
3 coats painting on other woodwork, walls of lobbies and lower walls of kitchens, sculleries, and stairs, superficial yards		<u>2800-0-0</u>

3 coats painting on skirtings and beltings, girth 6", lineal yards	600-0-0
Drawing line at top of lower walls.....lineal yards	<u>600-0-0</u>
1 coat staining in shades with dark mouldings and 3 coats varnish on woodwork of shops, viz.:	
wall linings.....160-0×4-6	
wall linings.....130-0×5-0	
wall linings.....70-0×3-6	
doors10 each 4-0×7-6	
Superficial yards	-----
1 coat staining in shades and 3 coats varnish on staff beads, girding 3½".....lineal yards	125-0-0
Painting vermilion and varnish on edges of shelves, lineal yards	<u>300-0-0</u>
3 coats painting approved color on 18 room chimney pieces.....	
3 coats painting black on 33 kitchen chimney jambs, lin- tels and shelves.....	
Supplying 144 pieces paper for walls of rooms.....	
Hanging 144 pieces.....	
3 coats painting bronze green on stair railings, 2 sides.....each 40-0×4-0	
3 coats painting bronze green on iron stanchions of gates, 2 sides.....each 6-0×10-0	
3 coats painting bronze green on borrowed lights.....6 each 3-0×8-0	
Superficial yards	-----
3 coats painting bronze green on outside woodwork, viz.:	
17 windows.....each 6-0×9-0	
6 small windows.....each 3-0×7-0	
10 doors.....each 7-0×8-0	
Superficial yards	-----
3 coats painting bronze green on framing, girth 6" of shop front.....lineal yards	220-0-0
3 coats painting bronze green on framing, girth 9" of shop front.....lineal yards	20-0-0
3 coats painting bronze green on iron gutters..lineal yards	<u>10-0-0</u>
3 coats painting bronze green on conductors and soil pipes	30-0-0
3 coats painting bronze green on 32 ornamental ears ...	
3 coats painting bronze green on 3 iron cistern heads..	

- 3 coats painting bronze green on 6 iron clothes poles...
- 3 coats painting bronze green on 29 iron ventilation gratings
- 3 coats painting bronze green on iron stanchions of 18 windows

NOTES ON THE VARIOUS WORKS

EXCAVATOR WORK

The excavator is the person who undertakes to do all the digging operations in connection with the building. The tool generally used is the common spade, but there is often used a large scooped shovel which is drawn by a horse, especially where the soil is of a sandy nature. The prices per cubic yard for digging operations are regulated upon the condition of soil, whether it is hard or soft, and the time that would be taken in doing the specified quantity. In order to ascertain the cubic contents of excavating work done, it is necessary to find the data of the various levels of the ground previous to digging operations. The site for the proposed building may have a very uneven surface, and so it is necessary to reduce the elevated parts of the ground to the lowest level, which will be to the uniform level of the ground previous to digging for the underground work of the building. The instrument used for leveling is the Theodolite, which stands upon a tripod or three legs. It is generally placed in such a position that commands a favorable point to take observations of the whole surface, and where this is not accessible it has to be moved from place to place in order to gain the best available point. Within the Theodolite there are two cross films—and the center point is that which gives the observation of the number of feet as shown on the rod which is held up at the

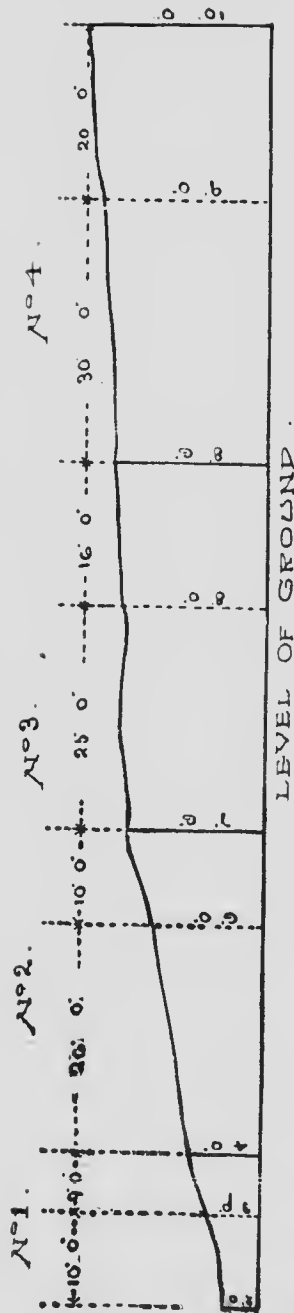

FIG. 26.

place where the level is to be taken. Firstly, however, a datum is to be taken of the place from which all the levels are to be regulated. Thus, often the corner of a wall of a neighboring house may be chosen, and a mark made by a chisel upon the wall indicating the point of vision taken while looking through the Theodolite. The index on the rod which it strikes is then noted in the observation book for future reference. When all the observatives are taken then they have to be regulated according to the rise and fall of the ground in comparison with the datum taken.

When the levels are taken and jotted down in the note book, then the calculations may be made in the office. The surface of the ground may be divided off into sections at the various points, and taken the average depth. Thus the various depths are taken and calculated on the various sections of the surface:—

Amount of digging for No. 1 section . . .	10-0 × 7-0 × 3-6
Amount of digging for No. 2 section . . .	26-0 × 10-0 × 6-0
Amount of digging for No. 3 section . . .	25-0 × 16-0 × 8-0
Amount of digging for No. 4 section . . .	30-0 × 20-0 × 9-0
	Cubic yards

This reduces it to the level surface of the ground and then the excavator may begin to do any undersurface digging that may be required. The digging of same may be ascertained in a like manner.

When all the levels are taken and quantities made out, it is necessary to describe the nature of the soil whether hard or soft, if the soil is to be wheeled to some part of adjacent ground or carted away altogether from the location. The excavator then can come to a proper basis upon which to regulate his price per cubic yard.

NOTES ON MASON AND BRICK WORKS

The term rubble is given to the rough stones that are generally used for the backing of walls where there is a facing of hewn work, or for walls of buildings where no facing is required. Common rubble is not hewn, but only shaped to the position it is to occupy in the building, and is generally not placed in any regular form. Square dressed rubble is hewn on the face to make the surface more regular and give it a better appearance. Ashlar is stone often used for the facing of walls, and is either polished or rock faced. Polished ashlar is generally used in the facing of buildings of a costly character, and those that are exposed in conspicuous positions to the public view. It presents a very pleasing appearance when built in regular courses. The thickness of ashlar is in general 6", and in courses 12" or 13" deep, and is set in mortar and jointed with putty. Rock faced ashlar is the face hewn rough in the center with a margin wrought round each block of stone. This is often adopted in buildings where a relief is desired from the plain or uniform face in other parts, and it has the effect of giving a rustic appearance which is a very pleasing contrast. Buildings of a castle or fortress character have very often this class of facing adopted in their construction which gives an imposing and bold effect to the general appearance. Another kind of ashlar is that which is termed drowed, and derives its name from being drowed

or hewn with a chisel and then placed in its position in blocks. Again there is vermiculated ashlar, that has the face hewn in a worm-like form in the center of the block with a margin of plain dressed or polished hewing round same. Again there is crow-toed ashlar which has the face done in the form of crows' toes. There are other kinds of hewing also adopted in dressing of stone, such as scabbled, striped, grooved, fluted and piended. There are also other varieties of stone, such as boulder stones and whin stones. The system of building with boulders has been in practice for several centuries. When we recall to mind the great walls that have been built by the Romans, notably the one stretching between the estuaries of the Forth and Clyde in Scotland, we have an example of the very early period in which it was adopted. Again when we see the ruins of some of the ancient castles or fortresses throughout Great Britain which have stood the test of time, and seen the practical purposes which boulder stones have served, we can well understand the durability of such material when properly built. The boulders are often found on the sides of mountains, on the margins of lakes, by the roadsides or in the fields. If they are found in the vicinity where it is proposed to build, then the expense of quarrying is saved, for they are generally on the surface or a little underneath the soil. In Scotland this method of building with boulders is frequently adopted and in many of the ancient towers and castles it may be seen. Although often, too, found built in their natural condition, yet they may be hewn to meet the requirements of the style of

Architecture used. The various kinds of stones have certain qualities which make them applicable to some particular style of building, and boulder stones are well adapted for the Baronial style where ruggedness and strength are the prominent characteristics. The sizes of boulder stones vary from 3 inches to 8 cubic feet, and are to be found in different colors, such as grey, blue, green, brown, red and several others. The various shades may be well adapted to give a pleasing effect to the building when placed in certain positions. Boulder stones can be utilized for window heads, window sills, window jambs, square corners, window arches, chimney-coping, door-steps, and other parts of the building, if required. When white boulder stones are used at corners of walls or at window jambs, and filled in with blue whin stones of different sizes in courses between, they present a pleasing appearance. The boulder stones are set in lime and neatly painted with black mortar and white lead in the key-drawn joint. Besides being used in the building of houses the boulder stones may be utilized with effect in building churches, and public buildings where strength and solidity are required, and may be hewn to the size and shape that may be best suited to the order of Architecture. Many of the dykes or walls that enclose the fields or rural districts of Scotland are built with boulder stones laid on the top of each other without mortar. These are not generally set in any regular order nor intended to be always permanent, as they may be removed from one position to another as may be required. Whin stone is found in different parts throughout Great

Britain, and is of a very hard and durable character. It is not easily hewn, but when it is made into regular shaped blocks and placed in proper positions in the building it presents a very neat and pleasing appearance. The dressings of corners, windows and doors have generally freestone, adapted to give contrast to the whin stone facing. Cottages or small houses have often whin stone as the facing for the outer walls, and it is very neat in appearance, when laid in courses 6 inches deep, and jointed with white putty. Churches or castellated buildings are also often built of this kind of stone, and it is very durable and well suited to withstand the influences of the weather. There is also the granite stone which is very little used in building and is principally utilized for the making of monuments, steps, pillars, columns, piers and other requirements. Sometimes the base part of buildings is done with this material and may be either rough or polished. It is very hard and consequently not so easily hewn, but when polished it presents a nice appearance, and is very durable. There are some localities, but very few where granite is to be found. Aberdeenshire in Scotland is where some of the best quarries are to be found, and notably in Aberdeen and Peterhead. The former city is called the Granite City, where nearly all the buildings are constructed with granite found in the district. There are other kinds of stone that may be used for building purposes such as marble, etc.

In treating of brick, there are two kinds which are often adopted in building; the common red and white brick. These again may be made smooth, and present a more

finished appearance to the building. Buildings that are built with brick and cement mortar are often very durable when good material is used, but if the brick be of a soft character the building would be apt very soon to give way. There are many purposes to which brick may be applied, but it is unnecessary to enumerate them. Brick is the best material for the construction of large chimney stalks and flues, and may be built with the red brick outside and white fire clay brick on the inside. Brick may be made into any shape by being moulded. Thus we have moulded cornices, rounded corners and splayed bases. We shall not touch upon the manufacture of the brick, as there are processes which would cause unnecessary detail.

NOTES ON CARPENTER AND JOINER WORK

In considering this subject we would notice the various kinds of timber and the practical purposes to which they may be applied. The timber that is exposed to the weather must be of a harder and more durable character than those for inside use, and according to the different parts of the work required to be done the timber that is most suitable is generally adopted. Thus white pine is often used for roofing spars, joisting etc., while American Yellow pine is adopted in the finishings, such as doors and lining of rooms. It is right to see that all timber be free from shakes, sapwood, large and loose knots and other imperfections before being used. There are many blemishes to be avoided in the choice of timbers, especially when they are to be used for very particular purposes. The timber must be thoroughly well seasoned, otherwise, there may arise several imperfections that will show themselves through time in the timber, caused by exposure. The timber for safe lintels, beams, wall plates, wall straps, hooks, window sashes and cases, frames and framing of outer doors are generally of Riga red pine. The finishings such as windows and doors are generally now done by machinery, whereas all the finishings in former times, used to be done by the hand and so a less amount of work was accomplished in the same space of time than what can now be done by the appliances at command. In all the various kinds of Joiner work there

are many tools used in their construction, and the manipulation of these require competent tradesmen to put together the various parts of the work. Great progress has been made in the manufacture of the more intricate and ornamental parts in the joiner work of the more costly buildings now erected, as new designs are being introduced and the methods adopted are carried out with great efficiency. We can now consider some of the details connected with Carpenter and Joiner works, the Joisting are made of different scantlings, such as 10" x 2", 11" x 3", and sleeper joists 3" or 4" x 2", which are generally laid on the ground floor and on land on asphalt joisting is often placed 18" to center and cross-keyed dwangs are placed between them to give strength to the joists over the width of area which they are to cover. The joists are often inserted on the ends in brick walls having iron or fire clay shoes, where they are inserted, to prevent the joists from taking fire. At the joints there are brilles into which the joists are inserted, and often they are half an inch thick to give strength for insertion of the joists, thus the brilles would be 10" for a 10" x 2 1/2" joist, and would be of the following kind:—

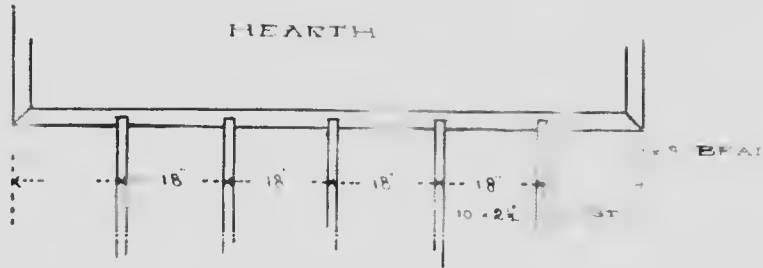

FIG. 27

On the top of the joists the flooring is laid which is generally 1 1/2" thick and in boards 5 or 6 inches in breadth or in wide boards 3" broad. The boards are generally tongued and grooved in the joints and well oiled and covered with wool well cleaned. The ceiling joists have the same strength as the floor joists, as they are of the same material, but are only laid on the inside. The ends of roof spars are secured tight by the poleplate thus:

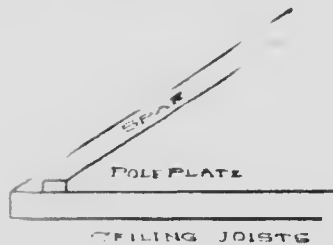

FIG. 28.

The pieces that build the spar are the center pieces that build the spar, which are on the sides, and the outerpieces are the spars and ceiling joists. On the top of the spar the sarking is 1/2" thick and the ridgeboard is on the top of the spars, and is either rounded on the top or having a rounded batten nailed on to form a roll for lead or zinc. Gutter boarding and bearers are placed in the valleys between roofs, and often snow staging above when required. Then there is the facing board which is used for the eaves for nailing the eave gutter to. The roof lights are composed of top, bottom and end rails also astragals for the glass. Louvre-boarded ventilators are

placed on the roof and may be made to any size as may be required. Over the openings in the walls there are the beams or safe lintels. They have generally a rest of nine inches on each side, and when inserted into the wall are rough, but when exposed over any opening they are dressed. Beams are made in different lengths, but should be specified if in long lengths, as the price will be more per lineal foot. Door frames may be described as per pair, giving the height of ceiling and the thickness of the brick partition in which they are placed. Thus:—one pair door frames in 4 $\frac{1}{2}$ " brick partition the ceiling 10' 0" high. Those door frames in standard partitions may be measured in a similar manner. Or again the frames and lintels for doors may be measured by the lineal foot. Partitions where standards are used are generally composed of 4"×2" standards placed 14" to centers, and having 4×2 runners at top and bottom and dwangs in center.

Windows are generally made 2 $\frac{1}{8}$ " thick and having cases. Windows may be with or without astragals, and if having small panes should be specified so, as an extra price would require to be charged. Windows may have circled or gothic shaped tops, and an extra charge should be made for forming same. Windows that have mullions or transoms should have the same specified and measured by the lineal foot giving breadth and thickness. Where spandril boards are, these should be described giving the extreme measurement. Windows are generally hung with lead or iron weights and strong hemp cord with brass faced axle pulleys. They may be hung on both sashes or only on one, but must be so specified. Doors

are made of various kinds of timber and different thicknesses. Two inches is the thickness of ordinary doors, which are generally for the outer doors or inner pass doors. Press and closet doors are generally made $1\frac{1}{2}$ " or $1\frac{3}{8}$ " thick. The number of panels in doors should always be specified and the kind of mouldings in the panels described, also whether it is square on the one side and mouldings on the other. In measuring bound partitions where the glass is in upper portions, the thickness of bound work should be taken and classed by the superficial foot, all mouldings and copes measured separately and astragals describing their size. The wainscoting on walls to be described giving the thickness and the mouldings and copes measured by the lineal foot.

The order in measuring Carpenter and Joiner works is to begin by taking the rough timbers first, such as safe lintels over openings, beams, wall plates, runners on brick partitions, sleeper and floor joists, door frames, ceiling joists and roof timbers. In taking the finishings begin with the upper floor and come downward. Firstly: Take all the windows in each room with their finishings, then all the doors with their finishings, and then the mantel-pieces and skirtings in each apartment. In the next story down take the same order. In the note book then you can see at once where to find each item and so have them classified and arranged in the completed measurement. After you have taken the rough timbers on a piece of paper that you have as a draft you may then take all windows with their finishings in one place, the doors with their finishings in another

with all ironmongery and then note these in proper order form same as described in Form of Estimate. The completed measurement should be kept in as near a form of order as detailed in the Estimate, as the prices in the Estimate can be better applied and placed in order in the measurement.

NOTES ON SLATER WORK

In many localities slates are not to be obtained, but in England and Scotland where there are several quarries, the slates are greatly utilized for the various buildings that are erected. The Westmoreland slates of the North of England and those of the Western Highlands of Scotland are chiefly in demand throughout Great Britain. Those from Westmoreland are green and of a durable character, and give a neat appearance to the roofs, when properly bonded. The slates from the western Highlands of Scotland are generally blue and can be had in various sizes. Slating in Canada is very seldom done, and when so, the slates are shipped from a considerable distance. Shingling is the method done generally throughout the Dominion, and when the roofing is painted it has the appearance of slates such as are used throughout Scotland. Slating makes a very durable and strong material for resisting the effects of snow and rain, as well as the sparks from fire. Although the prices of slates are much higher than shingles or any other material, yet it is to advantage, in getting roofs done with them, because of the durability and adaptability that they possess. The slates are generally three fourths square dressed and bored $1\frac{1}{2}$ " from top, having 3" of cover at the eaves gradually diminishing to 2" at the ridge and put on with galvanized steel or iron nails weighing 12 pounds per thousand. Slates can be put on in various patterns and shapes, but where they are more intricate than the common mode of slating, it requires considerably more time in arranging and fixing them.

NOTES ON PLASTER WORK

There are different kinds of material with which plastering is done. There is the common plaster composed of haired lime mixed with lime shells, and pure water. This after being made into the proper consistency is put on the walls and floated with a square piece of wood having a handle which is used for the purpose. The first coat of plaster is then left to thoroughly dry and then the second coat is put on, and when this coat is in a condition to receive the third coat, it is then put on and finished in a polished manner with white stucco plaster. This is then the last coat which completes the plastering of the walls in general cases, as three coats finished white makes a first class job. The walls then should be in a proper condition for receiving paint or any other material that may be desired to cover the same. There are also Portland and Roman cement which are used frequently in the plastering of walls. Then there is stucco or plaster of Paris that is used for the cornices and ornaments of the building. These can be run or moulded into any shape or form as may be desired. There are many kinds of ornaments adopted in the cornices. There is the modillion block, the egg and dart enrichment, the various kinds of floral ornaments, the dentil ornament, the patera ornament and several others that might be mentioned. Center flowers are made in different patterns and in various sizes.

NOTES ON PLUMBER WORK

This work is very important from a sanitary point of view and is worthy of great attention being given to its study and development. The roofs of buildings have generally lead used in the various parts that are exposed to the weather such as ridges and piends, valleys and round chimney stalks, and these lead pieces, should be well battened down and secured from being removed by storm. Zinc is also often used in connection with roof work, such as ridges and piends, valleys and round chimney stalks, etc. The conductors or pipes that convey the water from the roofs are of different bores or inside diameter, as the requirement demands. At the top of these pipes there are boxes or cistern heads in which the water is contained previous to its flow down the pipes. These pipes may be made round or square, and fastened by iron holdfasts or loose ears. At the top of some of the pipes where there are projections of plinths there are offsets projecting beyond the wall to allow the rain water to flow into the pipes. At the bottom there are shoes or bends to allow the water to flow from the pipes at the ground or there may be heel rests at the bottom for connecting at drains. The pipes or bends from sinks or jawboxes are often carried to the outside to join the rain water pipes. The jawboxes or sinks are generally placed in a convenient position next the outer wall, and are inclosed often with lining $\frac{3}{8}$ " thick and having a door in

same for access. The top part or sole board is at the end, while the hardwood cope is round the opening of sink. The position is thus:

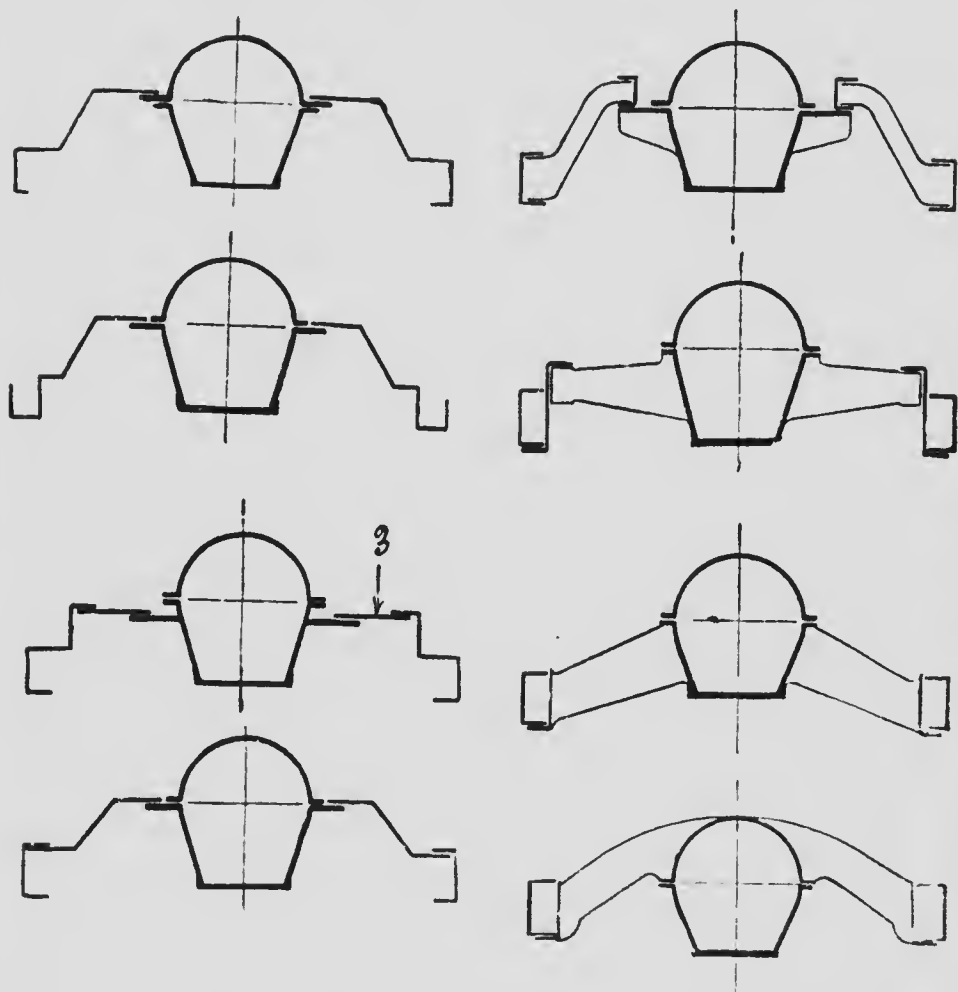

Inside the sink there is a plug and socket at the top of the waste pipe with chain attached, while there is a brass grating for allowing the water to discharge into the waste

pipe. There is also an overflow at the top of the sink for the water when it rises to a certain level. On the waste pipe from sink there is a cesspool, or trap, and a brass screw attached to give access for cleaning purposes. The water closets are often situated also near the outside wall so that the soil pipes may be carried down conveniently for discharge to the outside. The soil pipe is connected with the horn of closet and has also a bend or cesspool with screw for access to same for cleaning. The soil pipe is sometimes carried down inside the wall, but for sanitary purposes it is better that it be carried outside the wall, and having a grating on top for ventilation. On the down soil pipe outside the wall there are horns cast on for the reception of branch soil pipes from closets. At the bottom there are heel rests at connections of drains. The thickness of inside diameter of soil pipes is generally 5" or 4½". The bath pipes are more complex in their construction as often there are hot water pipes to be brought from the tanks where the hot water is generated. The cold supply pipes to baths, sinks and cisterns, as well as to hot water tanks, are brought up from the ground and carried through the building to their various places. The cold supply pipes to baths are led along to where the cranes are situated and the hot supply pipes also to their cranes. Then there are the other pipes such as the waste or discharge pipes, rod pipes, and fittings for baths. Baths may be fitted up with plunge, spray or shower. Hot water tanks are generally situated in the kitchen, where the pipes for the tanks may be led from the kitchen boiler. The revolving pipes are those between the tank and boiler. The other pipes from the tank convey the hot

water to the bath and sink. The fittings of the tank are generally 3 couplings for connecting pipes. The fittings for sinks and baths may be either made of brass or electro-plate or gun metal. The sanitary condition of the building or house depends greatly upon the method and perfect equipment of all the parts to the uses for which they are intended to accomplish the desired results. It is of importance that the water closet fittings and arrangement of its position in the house be particularly attended to, also the method in which the soil pipe is made perfectly air tight, and the connection it has to the drain, and exit of the soil therefrom. Ventilation of the soil pipe is very essential, and should be done in the most thorough method possible. The gasfitter work of a house is also of much importance where a supply of gas can be readily obtained. The pipe conveying the gas from the main is led into the house and connected to the meter which has an index that records the number of cubic feet consumed, and this may be priced per thousand feet and the cost ascertained. The pipes are made of composition or block tin and of various diameters or bores according to the number of lights required in the various apartments. They vary from 1½" to ¼" in diameter and according to the position of the apartment and the number of lights in it, the pipes will be led in the shortest method possible to save expense. Then there are couplings which connect the pipes at their junctions where they branch off to the several apartments. Brackets are fitted upon the walls or mantel-pieces, and gasaliers from the ceilings. These may be had at various prices, and from the plainest to the most elaborate design.

NOTES ON PAINTER WORK

Beauty and cleanliness, along with good taste are very essential elements in the finish of a building. The Painter's art is one of great importance in producing these when carried out in the most thorough manner. Painting may be done with various kinds of material. Thus we have oil color, and water color. The oil color gives a more durable condition and may be easily washed. The water color is of a cheaper material and can be used for common purposes. The oil paint can be made into various tints according to the class of work that may be desired. Harmony of color is very important in painting, as a deficiency in this respect displays a want of good taste. The work of a good painter should produce the highest artistic results. For this class of work the Decorator is brought into requisition, who requires to devote his time to the study and development of the newest and best designs, and produce original sketches for the various subjects that may be required. The decoration of churches, halls and public buildings call for the skill of the best artists, and this class of work becomes very expensive owing to the time required in gaining the experience of same, and the great care and taste displayed in producing the desired results.

FORM IN NOTE BOOK

MASON WORK

Measurement of the mason work of a tenement being erected in Fifth avenue by Thomas Smith, Esq.

2'0"	Rubble foundation of front wall.....	2-0×60-0×1-0
	Digging trench for foundation	3-0×61-0×1-0
2'0"	Rubble foundation of back wall.....	2-0×60-0×1-0
	Digging trench for foundation	3-0×61-0×1-0
2'0"	Rubble foundation of east gable.....	2-0×30-0×1-0
	Digging trench for foundation	3-0×31-0×1-0
2'0"	Rubble foundation of west gable.....	2-0×30-0×1-0
	Digging trench for foundation	3-0×31-0×1-0
1'6"	Rubble foundation of walls of wing..	1-6×60-0×1-0
	Digging trench for foundation	2-6×62-0×1-0
	Digging area of tenement	45-0×36-0×2-6
2'0"	Rubble front wall of tenement above foundation	58-0×36-0
	Deduct 6 windows, ground floor	each 3-0× 6-6
	1 cross open.....	4-0× 9-0
	7 windows, first floor,	each 3-0× 7-0
	7 windows, second floor	each 3-0× 8-0
	7 windows, third floor	each 3-0× 7-6
2'0"	Rubble back wall..	58-0×36-0
	Deduct 26 windows..	each 3-0× 6-6
2'0"	Rubble east gable above foundation,	28-0×36-0

	Deduct 3 windows, ground floor		ea	3-0	6-6
	3 windows, first floor		ea	3-0	7-0
	3 windows, second floor		ea	3-0	8-0
	3 windows, third floor		ea	3-0	7-6
2 0"	Rubble foundation west gable above foundation			28-0	36-0
	Deduct 3 windows, ground floor		ea	3-0	6-6
	3 windows first floor		ea	3-0	7-0
	3 windows second floor		ea	3-0	8-0
	3 windows, third floor		ea	3-0	7-6
					Superfl yds.
1 0"	Rubble walls of wing			58-0	36-0
	Deduct 12 windows, 1 door		ea	3-0	7-6
				3-6	7-0
	Rybat of openings in front wall, having droved margin and scuncheons, per estimate				Superfl yds.
		12	each	6-6	
		2	each	9-0	
		14	each	7-0	
		14	each	8-0	
		11	each	7-6	
	Rybat of opening in back wall, having droved margin and scuncheons, per estimate	52	each	6-6	
	Rybat of openings in east gable having droved margin and scuncheons, per estimate	6	each	6-6	
		6	each	7-0	
		6	each	8-0	
		6	each	7-6	
	Rybat of openings in west gable, having droved margin and scuncheons, per estimate	6	each	6-6	
		6	each	7-0	

	6	each	8-0	
	6	each	6-0	
			Lineal feet	
Ry bats of openings, in 1'0" walls of wing	24	each	7-6	
	2	each	7-0	
			Lineal feet	
Lintels over open- ings in front wall	27	each	4-6	
	2	each	5-6	
			Lineal feet	
Lintels over open- ings in back wall	26	each	4-6	
Lintels over open- ings in east gable	12	each	4-6	
Lintels over open- ings in west gable	12	each	4-6	
			Lineal feet	
Lintels over open- ings in walls of wing	12	each	4-6	
	2	each	5-0	
			Lineal feet	
Droved projecting window sills in front wall	27	each	5-0	
Droved projecting window sills in back wall	26	each	5-0	
Droved projecting window sills in east gable	12	each	5-0	
Droved projecting window sills in west gable	12	each	5-0	
Droved projecting window sills in walls of wing	12	each	5-0	
			Lineal feet	
Droved stone door steps	2	each	3-6	
	2	each	4-0	
			Lineal feet	
Droved stone plinth on wall head of front wall			61-0	
Droved moulded course on front wall			60-0	

TO CORRECT MEASUREMENTS

12" x 6"	Dressed ashlar chimney stalk on front wall				
	Dressed stone cope			16-0 x 9-0	
	Cutting and counter-sinking cope for 10 chimney pots ..			7-0	
	Rubble building of seats under 3 hearths, ground flat				
	Widened hearths, inner	10	ea	3-0 x 1-0	
	outer	10	ea	4-6 x 1-6	
	10 set chimney jambs and lintels				

BRICK-WORK

4½"	Brick partitions in ground flat	206-0	×10-0
	Deduct 10 doors	each	3-0 × 6-0
	Add partitions up one stair	220-0	×10-0
	Deduct 12 doors	ea	3-0 × 6-0
	Add partitions up 2 stairs	220-0	×10-6
	Deduct 12 doors	ea	3-0 × 6-0
	Add partitions up 3 stairs	220-0	×11-0
	Deduct 12 doors	ea	3-0 × 6-0
	Plumbing scunchions of doors	92	ea 6-0
9"	Brick building of wall at end of wing	10-0	×6-0
	Brick foundation for wing	11"	× 10-0 × 0-4

FORM IN NOTE BOOK

CARPENTER AND JOINER WORKS

	Safe lintels over windows in front wall.....	6	ea	4-6×10-4
	Safe lintels over closs open.....			5-6×10-6
	Safe lintels over windows, first floor	7	ea	4-6×10-4
	Safe lintels over windows on second floor.....	7	ea	4-6×10-4
	Safe lintels over windows, third floor.....	7	ea	4-6×10×4
	Safe lintels over windows in back wall.....	26	ea	4-6×10×4
	Safe lintels over windows in east gable.....	12	ea	4-6×10×4
	Safe lintels over windows in west gable.....	12	ea	4-6×10×4
	Safe lintels over windows in wing,	12	ea	4-6×8×4
	Safe lintels over door.....			4-6×8×4
10"×6"	Dressed beam over opening in wall, ground flat.....			10-9
4½"×1"	Runners on bearing partitions.....			605-0
	22 pair door frames in 4½" brick partitions, the ceiling 10'6" high			
	12 pair door frames, in 4½" brick partitions, the ceiling 10'6" high.....			

	12 pair door frames, the ceiling 11'0" high.....			
	10 pair wall press door frames.....			
	184 dooks for door frames in 4 1/2" brick partitions..			
6"×1"	Wall plates under sleepers in ground flat.....			106-0
9"×1"	Wall plates under joists.....			600-0
10"×1 1/2"	Wall plates under roof.....			300-0
6 1/2"×2 1/2"	Sleeper joists.....	34	each	20-0
		17	each	31-0
		8	each	20-0
10"×2 1/2"	Joisting of first floor in 36 1/2' lengths..	10	each	36-6
10"×2 1/2"	Joisting of first floor in 20 1/2' lengths..	10	each	20-6
10"×3"	Bridles at hearths..	3	each	4-6
		3	each	2-0
		4	each	1-6
10"×1 1/2"	Slip joists at partitions.....	3	each	8-6
		3	each	7-0
		4	each	7-6
10"×2"	Solid dwangs between joists..	12	each	30-0

Roofing.

6 1/2"×2 1/2"	Ceiling joists placed 18" to center....	10	each	17-0
		7	each	11-0
		9	each	12-0
6 1/2"×2 1/2"	White dram roof spars placed 18" to center.....			
	2 sides each			30-0×24-0
11"×1 1/2"	Ridgeboard, rounded on top....		lin' ft	30-0
11"×1 1/2"	Picard rafter..	4	each	26-0
5"×2"	Balks and roof pieces....	12	each	5-6
		1	each	10-0
		2	each	7-0

58"	White pine sarking on roof		0-0×24-0
	Cutting and fitting sarking at piers		lin'l ft. 104-0
	Deafening boarding of 3 upper floors.	3	ea 36-0×26-0
	Deduct 6 hearths.		ea 4-6×1-6
	Straps with grounds on walls of ground floor		124-0×10-0
	Deduct 12 windows.		ea 5-0×9-0
	1 crossopen		4-0×9-0
	Add on walls of three upper floors		124-0×31-6
	Deduct 18 windows.		5-0-0-0
118"	White dram flooring of ground floor.		36-0×26-0
118"	White dram flooring of three upper floors	3	ea 36-0×26-0
	Deduct at 10 hearths.		ea 4-6×1-6

Windows.

	12 d. h. windows in ground floor		ea 3-9×6-8
	13 d. h. windows in first floor.		ea 3-9×7-2
	13 d. h. windows in second floor.		ea 3-9×8-2
	13 d. h. windows in third floor		ea 3-9×7-8
4"×58"	Individual facings to windows.	12	ea 23-0
		18	ea 23-0
114"	Bound lining with sunk planted mouldings on sides of windows.	60	ea 1-2×7-0
114"	Bound lining with sunk planted mouldings on sides of windows.	36	ea 1-2×7-0
114"	Bound lining with		

5/8"	breasts and elbows of windows	48 ea	6-4×2-0
	Beaded coping on windows	48 ea	6-4
	30 pair base blocks to windows		
	30 pair china shutter knobs		
	30 brass sash fasteners with screws, Putting on ironmongery of 30 windows with mock shutters ...		
	120 strong sash fasteners and screws		
	240 strong ring sash litters and screws ..		
	66 brass shutter knobs and shields		
	36 ebony shutter knobs and shields		
	12 pair 3" edge hinges and screws		
	6 iron shutter bars each 18" long with keepers and screws		

Doors with their Frames and Furnishings

5"×2"	Cleaned frames for porch doors in shops	6 each	20-0
6 1/4"×2"	frames for doors in 1 1/2" brick partitions		
	27 pair frames, the ceilings from 10' to 10'3" high, having 1 1/2" brick partition		
	36 pair frames, the ceilings from 10'		

		to 10'3" high, having double lintel for faulight.....			
3½"×1½"	36 pair frames to wall press doors				
6"×2"	Cleaned frames for inside doors at small houses	12	each	15-0	
2¼"×2"	Cleaned frames for doors to water closets, lavatories and sculleries....	2	each	15-0	
		2	each	16-0	
		2	each	20-0	
4½"×2¼"	Cleaned frames for gates dooked to brick.....	2	each	20-0	
	Bound two leaved porch doors in shops, per estimate.....	6	ea	4-0×7-0	
3"×2¼"	Moulded and checked framing of faulights with planted glass checks..	4	each	16-0	
¾"	Best British polished plate glass in panes from 6 to 8 superficial feet, including glazing.....	4	ea	6-0×10-0	
1¾"	Bound entrance doors having planted mouldings both sides ..	18	ea	3-0×7-0	
	9 Bound two leaved having planted doors ..	9	ea	4-0×8-0	
1½"	Bound press doors..	6	ea	3-0×7-0	
	Bound press, closets, scullery and lavatory doors	3	ea	3-0×7-0	
		3	ea	3-0×6-0	
		3	ea	3-0×5-6	
17/8"	Framed and lined doors to water closets, per estimate	2		3-0×6-0	
2"	Framed and lined gates to water				

	closets, per estimate	2	4-0×7-0	
6"×2"	Cleaned frames for borrowed lights,	2	20-0	
2"	Fixed borrowed lights glazed with 1/4" rough cast plate glass	2	3-0×3-0	
2"	Fixed fan lights, glazed with 21 oz. sheet glass	2	3-0×2-0	
	Labor working beaded and checked edges of two-leaved doors.....	2	6-0	
5/8"	Beaded checks.....	2	12-0	
	Fillet checks.....	2	14-0	
6"×5/8"	Beaded checks round ingoing of small opening in 4 1/2 partitions at beds.	2	10-0	
4 1/2"×1 1/4"	Rounded berges at entrance doors ..	2	3-0	
4 1/2"×1 1/4"	Rounded berges at inner doors to small houses.....	6	3-0	
5/8"	White pine lining with grounds on sides and soffits of inner doors...	2	14-0×1-0	
4 1/2"×3/4"	Moulded facings in rooms, lobbies and stairs.....	2	14-0	
		2	16-0	
		2	15-0	
4"×5/8"	Moulded facings in kitchens, sculleries, closets and shops	2	each 14-0	
		2	each 16-0	
		2	each 12-0	
	30 pair base blocks to facings			
3/4"	Double beaded transom facings	2	each 6-0	
	Labor fitting and hanging 100 doors			
	Labor fitting and			

	hanging 15 two-leaved doors.... Putting ironmongery on 160 doors Putting ironmongery on 20 two-leaved doors Putting ironmongery on 6 fanlights 32 pair 7" hinges and screws 16 pair 6" hinges and screws 10 pair 5" hinges and screws 6 mortice 4" lever locks having ebony and bronzed crank handles on both sides 20 8" rimlocks with check box and milled edge brass mounting.. 12 8" mortice locks with Mace's patent ebony mounting one side 12 kitchen latches, per estimate ... 10 4½" rim latches... 10 5" press locks.... 10 sets Mace's patent brass mortice mounting..... 10 set Mace's patent ebony mortice mounting..... 3 6" galvanized locks for gates.....			
6" x 5/8"	Moulded skirting and grounds in rooms.....	2	each	12-0
		2	each	18-0
		2	each	15-0
6" x 5/8"	Moulded skirting and grounds in			

	kitchens, sculleries and closets.	2	each	30-0
		2	each	25-0
		2	each	19-0
4"×5 1/8"	Moulded utensil belting with dooks	2	each	15-0
		2	each	20-0
		2	each	18-0
6"×5 1/8"	Double moulded hat belting	2	each	16-0
		2	each	12-0
		2	each	10-0
1 1/4"	Corner beads with dooks	2	each	20-0
		2	each	19-0
		2	each	17-0
8"×1"	Cleaned shelves with dooks at kitchen fireplaces	4	each	6-0
7/8"	Shelving	2	ea	16-0×1-0
		2	ea	12-0×1-6
		2	ea	11-0×1-3
	Working rounded corners			
	Strong framed open brackets			
1 1/2"	Cleaned fir tops of dressers	2	ea	6-0×3-0
	Cleaned fir tops of bunkers	2	ea	5-0×2-6
7"×5 1/8"	Moulded skirting...			1-8-0
				1-6-0
	Working 30 moulded return ends.....			
	Dovetailed drawers:			
	Bottoms.....	2	ea	1-6×1-0
	Sides and ends...	2	ea	5-0×0-0
1 1/4"	Board doors with planted mouldings	2	ea	3-0>
3"×1 1/2"	Cleaned framing...	2	each	2-0
		2	each	1-0
		2	each	1-0
	Fillets and sliders for drawers.....			
7/8"	Sparred shelves 1" apart	2	ea	20-0×3
	Bars on back	2	each	20
1/8"	Plan shelves	2	ea	20-0×1-0

1 1/8"	Rough bottoms of coal boxes	2	ca	4-0 x 2-0	
1 1/8"	Batten lining dressed and chamfered . .	2	ca	6-0 x 3-0	
3" x 3"	Round and chamfered corner posts	3	each	3-0	
1"	Corner beads on angle	3	each	3-0	
	Extra for forming hinged parts of front and top of 2 coal boxes				
	2 pair 2" strong backfold hinges and screws				
	2 Japanned iron hooks and eyes on plates and screws				
	Labor fitting and hanging 2 small, two-leaved doors.				
	Putting ironmongery on 2 dressers, and coal boxes				
	2 pair 3" edge hinges and screws				
	2 strong hooks and eyes on plates and screws				
	2 black drawers, cup handles and screws				
3" x 2"	Cleaned framing forming bed closet	2	each	6-0	
		2	each	3-0	
		2	each	4-0	
1" x 2"	Cleaned framing forming ground for lining	2	each	5-0	
		2	each	4-0	
2 3/4" x 2"	Cleaned and stop chamfered framing at openings . .	2	each	6-0	
		2	each	8-0	
		2	each	4-0	
1 1/8"	Pitch pine lining, grooved, beaded				

	and chamfered joints in front of dressers and coal boxes.	12 ea	15-0	3-0
5/8"	Beaded checks of doors.	1 ea	2-0	
4" x 7/8"	Beaded cope.	12 ea	10-0	
5/4"	Moulding under beaded cope.	12 ea	10-0	
1 1/4" x 1 1/4"	18 malleable iron angle pieces each 14" long at junctions of copes and standards, fixed with screws.			
5/8"	Galvanized iron curtain rod having bent palm ends, fixed with screws.	12 ea	5-0	
5/8"	Narrow chamfered lining backs of room presses.	12 ea	3-0	7-0
7/8"	Cleaned white pine boarding on in going.	12 ea	17-0	1-0
7/8"	Cleaned shelving.	24 ea	3-0	1-0
	Labor cutting rangles for shelving.	48 ea	3-0	
5/8"	Beaded slips.	12 ea	17-0	
5" x 5/8"	Chamfered skirting.	12 ea	3-0	

FORM IN NOTE BOOK

SLATER WORK

The sketches of roofs are the principal things to be taken in note book, and great care must be observed so that not one single measurement be omitted to be jotted down, otherwise the contents cannot be ascertained. It is advisable that the sketches be carefully examined for this purpose before coming off the roofs. The contents of area of roofs may easily be obtained by dividing the various parts into triangles, parallelograms or squares, according to the shape of the roofs. The pointing of raggles and skews may be taken also when upon the roofs and jotted down, and any other work done by slater.



MICROCOPY RESOLUTION TEST CHART

ANSI and ISO TEST CHART No. 2



APPLIED IMAGE Inc.

10000 11th Mon. Street
Newington, New Hampshire 03801
Tel: 603-883-3100
Fax: 603-883-3101

FORM IN NOTE BOOK

PLASTER WORK

Upper Floor of one Tenement

3 coats polished plaster on ceiling of parlor, south house.....	13-6×10-0
Walls square	47-0× 9-6
Deduct 1 window.....	5-0× 8-6
2 doors	all 6-0× 7-0
8"×6" cornice as walls.....	Lineal feet 47-0
4 miters	
1 center flower 4-0 diameter.....	
1 coat plaster behind window linings, breast...	7-0×2-6
1 coat plaster behind window linings, sides, 2 ea	1-0×7-0
1 coat plaster behind press lining.....	3-0×7-0
3 coats polished plaster ceiling of bedroom...	12-0×8-0
Walls square	40-0×9-6
6×4 cornice as walls	Lineal feet 40-0
4 miters.....	
Deduct 1 window from walls	4-6×8-6
1 door	3-0×7-0
1 coat plaster behind window linings, breast...	6-6×2-6
1 coat plaster behind window linings, sides, 2 ea	1-0×7-0
3 coats polished plaster ceiling of kitchen.....	12-0×9-0
Except	7-0×2-0
3 coats polished plaster walls square	42-0×9-6
3 coats polished plaster ceiling of bed	6-6×4-0
3 coats polished plaster walls	21-0×9-6
Deduct 1 window	5-0×8-6
1 door to bed	2 sides each 3-0×7-0
1 door and fanlight.....	3-0×9-0
1 coat plaster behind window linings, breast...	7-0×2-6
1 coat plaster behind window linings, sides, 2 ea	1-0×7-0
1 coat plaster in press.....	3 0×7-0
3 coats polished plaster ceiling of lobby.....	8-0×7-0

Walls square	30-0×9-6
Deduct 2 doors	each 3-0×7-0
2 doors and fanlights.....	each 3-0×9-0
6"×4" cornice as walls.....	Lineal feet 30-0
4 miters.....	
3 coats polished plaster on ceiling of parlor,	
north house	12-10×10-0
Walls square	45-8×9-6
8"×6" cornice as walls.....	Lineal feet 45-8
4 miters	
1 center flower.....	
1 coat plaster behind window and press linings as last	
parlor	
3 coats polished plaster ceiling of bedroom... 12-0×7-10	
Walls square	39-8×9-6
6"×4" cornice as walls.....	Lineal feet 39-8
4 miters.....	
Deduct 1 window, as south house	
1 door, as south house	
1 coat plaster at window as south house.....	
3 coats polished plaster on ceiling of kitchen .. 12-0×9-0 }	
Except 7-0×2-0 }	
3 coats polished plaster on walls square	42-0×9-6
Otherwise same as kitchen in south house.	
3 coats polished plaster on ceiling of lobby.... 8-6×6-10	
Walls square	30-8×9-6
Deduct 2 doors, as south house	
2 doors and fanlights, as south house.....	
6"×4" cornice as walls	Lineal feet 30-8
4 miters.....	

Up Two Stairs.

All same as upper floor except:

Height of walls	×9-0
Height of breast of windows.....	×2-3
Height of sides of windows.....	×7-0
Press linings as above	

Up One Stair.

All same as upper floor except:

Height of walls	×9-0
Height of breast of windows.....	×2-3

Height of sides of windows.....	×7-0
Press linings as above	

Ground Floor.

3 coats polished plaster on ceiling of parlor, south house	13-6 × 8-6
Walls square	44-0 × 10-0
Deduct 1 window	5-0 × 8-6
1 door	3-0 × 7-0
8" × 6" cornice as walls.....	Lineal feet 44-0
4 miters.....	
1 center flower	
1 coat plaster behind window linings, breast....	7-0 × 3-0
1 coat plaster behind window linings, sides, 2 ea	1-0 × 7-0
1 coat press lining as above.....	
3 coats polished plaster on ceiling of bedroom.....	12-0 × 8-0
Walls square	40-0 × 10-0
6" × 4" cornice as walls.....	Lineal feet 40-0
4 miters	
3 coats deduct 1 window	4-6 × 8-6
1 door	3-0 × 7-0
1 coat plaster behind window linings, breast....	6-6 × 2-6
1 coat plaster behind window linings, sides, 2 ea	1-0 × 7-0
3 coats polished plaster ceiling of kitchen	12-0 × 9-0
	Except 7-0 × 2-0
3 coats polished plaster walls square	42-0 × 10-0
3 coats polished plaster ceiling of bed	6-6 × 4-0
3 coats polished plaster walls.....	21-0 × 10-0
Deduct 1 window	5-0 × 8-6
1 door to bed.....	2 sides each 3-0 × 7-0
1 door and fanlight.....	3-0 × 9-0
1 coat plaster behind window lining, breast....	7-0 × 2-6
1 coat plaster behind window lining, sides, 2 ea	1-0 × 7-0
1 coat plaster in press	3-0 × 7-0
3 coats polished plaster ceiling of lobby	8-0 × 7-0
Walls square	30-0 × 10-0
Deduct 2 doors each.....	3-0 × 7-0
2 doors and fanlights	each 3-0 × 9-0
6" × 4" cornice as walls.....	Lineal feet 30-0
4 miters.....	
3 coats polished plaster on ceiling of parlor, north house	12-10 × 9-0

Walls square	43-8×10-0
Deduct 1 window, same as in south house	
1 door, same as in south house	
8"×6" cornice of walls	Lineal feet 43-8
4 miters	
1 center flower	
1 coat plaster behind window linings, breast...	7-0×3-0
1 coat plaster behind window linings, sides, 2 ea	1-0×7-0
1 coat plaster behind press lining as above	
3 coats polished plaster on ceiling of bedroom.	12-0× 8-0
Walls square	40-0×10-0
Deduct 1 window	4-6× 8-6
1 door	3-0× 7-0
1 coat plaster behind window linings same as in south house	
3 coats polished plaster ceiling of kitchen...	12-0× 9-0
Except	7-0× 2-0 }
3 coats polished plaster on walls	42-0×10-0
3 coats polished plaster ceiling of bed	6-6× 4-0
3 coats polished plaster walls	21-0×10-0
Deduct 1 window	5-0× 8-6
1 door to bed	2 sides each 3-0× 7-0
1 door and fanlight	3-0× 9-0
1 coat plaster behind window and press linings, same as in south house	
3 coats polished plaster ceiling of lobby	8-0× 7-0
Walls square	30-0×10-0
Deduct 2 doors	each 3-0× 7-0
2 doors and fanlights	each 3-0× 9-0
6"×4" cornice as walls	Lineal feet 30-0
4 miters	

Staircase and Closs.

3 coats polished plaster on ceiling of staircase.	17-0× 9-0
Walls square	52-0×40-6
Add on newel	19-0×31-0
Add on ceilings of landings	3 each 9-0× 4-0
Add on ceiling of closs	20-0× 4-0
Add on walls of closs	40-0×10-0
Add on walls of closs next back	36-0× 9-0
Deduct 3 stair windows	each 4-6× 8-0
8 entrance doors	each 4-0× 8-6

Cement on lower walls of stair and newal, etc	250-0	×4-6
Portland cement on lower walls of staircase, newal, etc	250-0	× 4-6
Rounding plaster corners	3	each 10-0
	4	each 6-0
	8	each 9-0
Relieving wood corner beads	5	each 3-0
	7	each 6-0
Bedding and pointing 24 window cases.....		

FORM IN NOTE BOOK

PLUMBER WORK

In measuring the roof work you can only measure the various items so far as you can get conveniently within their reach and proceed along the roof in the direction which will enable you to overtake all the work thereon, so that the different pieces of material will require to be arranged in proper order when making out the complete measurement.

ROOF AND OUTSIDE WORK

7 lb. sheet lead lining center gutter.....	26-0	×	2-6	
6 lb. sheet lead ridge of roof.....	40-0	×	1-3	
6 lb. sheet lead piends.....	4 each	30-0	×	1-3
6 lb. sheet lead flank	32-0	×	1-6	
5 lb. sheet lead apron round chimney stalks, 4 ea.	24-0	×	1-3	
5 lb. sheet lead skews at chimney stalks, 8 each	12-0	×	1-6	
Lead batts in raggles	4 each	24-0		
80 galvanized iron straps for ridge and piends.....				
5"×4" castiron moulded eave gutter.....	60-0			
2 castiron moulded close ends				
2 castiron drops or outlets				
2 copper rose gratings in gutters				
3" lead bends from gutters.....	2 each	3-0		
4½"×3½" castiron conductors from roofs ..	2 each	40-0		
2 cast iron bends at bottom				
10 castiron ornamental ears.....				
2 castiron ornamental cistern heads.....				
3" c stiron round conductors and waste pipes				
from jawboxes	2 each	56-0		
branches	8 each	6-0		
2 castiron single bends or shoes at bottom				
2 castiron offsets at top.....				

8 castiron branch pieces for waste pipes	
8 castiron branch horns cast on	
4½" castiron soil pipes from water-closets...2 each	40-0
2 castiron bends with heel rests at bottom.....	
8 castiron horns for branches	
8 castiron branch pieces.....	
4½" castiron light air pipe above soil pipe...2 each	10-0
2 cowls for top of light air pipe	

INSIDE WORK

Upper Floor

¾" lead main upright supply pipe (11 lbs. per yard) to sinks.....2 each	10-0
½" lead branch to upright supply pipe.2 each	1-6
2 white enameled sinks, per estimate	
2 hydraulic drawn 5" traps of 7 lb. lead.....	
2 brass table washers with plugs and chains.....	
2 heavy brass nose cocks	
2 lead collars connecting horns.....	
1½" galvanized iron service pipe to water-closets, 2 ea	10-0
Labor forming 2 offsets on service pipe.....	
¾" lead upright supply to water-closets (11 lbs. per yard)	2 each 10-0
½" lead branches (7 lbs. per yard)	2 each 3-0

Up Two Stairs

All same as upper floor.

Up One Stair

All same as up 2 stairs.

Ground Floor

All same as up 1 stair.

¾" lead main supply pipe (11 lbs. per yard) from street to inside of building.....	60-0
2 brass underground stop cocks on supply	
2 brass screwed ferrules	
1 castiron stop cock case	
1 castiron horse shoe cover.....	
1 brass cleansing cock with coupling tail.....	
1 malleable iron stop cock key	

FORM IN NOTE BOOK

PAINTER WORK

Upper Floor of 1 Tenement

1 coat oil paint and size tinting ceiling of parlor, south house	13-6×10-0
Off cornice	1-4 and 1-4
1 coat oil paint and size tinting cornice, girding about 24"	47-0
1 coat oil paint and size tinting on center flower, 4'0" diameter	
Supplying 8 pieces paper for walls	
Sizing for and hanging for 8 pieces	
3 coats oil paint, grained imitation oak on window and shutters	24-0×7-0
3 coats oil paint, grained imitation oak on soffit	7-0×2-0
3 coats oil paint, grained imitation oak on breast	14-0×2-3
3 coats oil paint, grained imitation oak on 1	5-0×7-6
	Superficial yards
3 coats oil paint, grained imitation oak on skirting, girth 12"	30-0
3 coats oil paint, grained imitation oak on 1 mantelpiece	
1 coat oil paint and size tinting ceiling of bed- room	12-0×8-0
Off cornice	1-0 and 1-0
1 coat oil paint and size tinting cornice, girding about 15"	40-0
Supplying 6 pieces paper for walls	
Sizing for and hanging 6 pieces	
3 coats oil paint in shades on window and bound lining	9-0×7-3
3 coats oil paint in shades on soffit	6-0×2-0

3 coats oil paint in shades on breast	7-6×2-6	
3 coats oil paint in shades on 1 door.....	5-0×7-6	
	Superficial yards	
3 coats oil paint in shades on skirting, girth 10".....		33-0
3 coats of oil paint in shades on 1 small mantel piece...		
Size tinting ceiling of kitchen.....	12-0×9-0	
Size tinting walls of kitchen	12-0×9-0	
Size tinting ceiling of bed.....	6-6×4-0	
Size tinting walls	21-0×9-0	
Deduct 1 window.....	5-0×8-6	
1 door to bed.....	2 sides each 3-0×7-0	
1 door and fanlight	3-0×9-0	
	Superficial yards	
3 coats oil paint in shades on woodwork of window	7-6×7-3	
3 coats oil paint in shades on woodwork of soffit	4-6×2-0	
3 coats oil paint in shades on woodwork of breast	8-0×2-3	
3 coats oil paint in shades on woodwork of 1 door	5-0×7-5	
3 coats oil paint in shades on woodwork of 1 door and fanlight.....	5-0×9-0	
3 coats oil paint in shades on lining enclosing dresser	12-0×3-0	
3 coats oil paint in shades on lining enclosing sink.....	6-0×3-0	
	Superficial yards	
3 coats oil paint in shades on skirting, girth 6" ..	20-0	
Painting stone jambs and lintel of fireplace, 3 coats black		
Size tinting ceiling of lobby	8-0×7-0	}
Off cornice	1-0 and 1-0	
Size tinting walls	30-0×9-0	
Deduct 2 doors	each 3-0×7-0	
2 doors and fanlights	each 3-0×9-0	
	Superficial yards	
3 coats oil paint in shades on plain cornice, girding about 12"	30-0	
3 coats oil paint in shades on 2 doors....	2 each 4-6×7-0	
3 coats oil paint in shades on 2 doors and fanlights	each 4-6×9-0	
	Superficial yards	

3 coats oil paint in shades on skirting, girth 8"	18-0
1 coat oil paint and size tinting ceiling of parlor, north house	12-10×10-0
Off	1-1 and 1-4
1 coat oil paint and size tinting cornice, girding about 24"	45-8
1 coat oil paint and size tinting center flower 4' diameter, Supplying 8 pieces paper for walls	
Sizing for and hanging 8 pieces	
3 coats oil paint, grained imitation oak and 1 coat varnish on window and shutters	21-0×7-0
3 coats oil paint, grained imitation oak and 1 coat varnish on soffit	7-0×2-0
3 coats oil paint, grained imitation oak and 1 coat varnish on breast	14-0×2-3
3 coats oil paint, grained imitation oak and 1 coat varnish on 1 door	5-0×7-6
	Superficial yards
3 coats oil paint, grained imitation oak and 1 coat varnish on skirting, girth 12"	37-0
3 coats oil paint, grained imitation oak and 1 coat varnish on 1 mantel piece	
1 coat oil paint and size tinting ceiling of bedroom	12-0×7-10
Off cornice	1-0 and 1-0
1 coat oil paint and size tinting cornice, girding about 15'	39-8
Supplying 6 pieces paper for walls	
Sizing and hanging 6 pieces	
3 coats oil paint in shades on window and bound lining	9-0×7-3
3 coats oil paint in shades on soffit	6-0×2-0
3 coats oil paint in shades on breast	7-6×2-6
3 coats oil paint in shades on 1 door	5-0×7-6
	Superficial yards
3 coats oil paint in shades on skirting, girth 10"	32-0
3 coats oil paint in shades on small mantelpiece	
Size tinting ceiling of kitchen	12-0×9-0
	Except 7-0×2-0
Size tinting walls	42-0×9-0
Size tinting ceiling of bed	6-6×4-0
Size tinting walls	21-0×9-0

Deduct 1 window	5-0×8-6	
1 door to bed	2 sides each 3-0×7-0	
1 door and faulight	3-0×9-0	
	Superficial yards	<hr/>
3 coats oil paint in shades on woodwork of window	7-6×7-3	<hr/>
3 coats oil paint in shades on soffit	4-6×2-0	
3 coats oil paint in shades on breast	8-0×2-3	
3 coats oil paint in shades on 1 door.....	5-0×7-6	
3 coats oil paint in shades on 1 door and faulight	5-0×9-0	
3 coats oil paint in shades on lining enclosing dresser	12-0×3-0	
3 coats oil paint in shades on lining enclosing sink	6-0×3-0	<hr/>
	Superficial yards	<hr/>
3 coats oil paint in shades on skirting, girth 6"	20-0	<hr/>
Painting stone jambs and lintel of fireplace 3 coats black.....		<hr/>
Size tinting ceiling of lobby.....	8-0×7-0	}
Off cornice	1-0 and 1-0	
Size tinting walls	30-0×9-0	
Deduct 2 doors.....	each 3-0×7-0	
2 doors and faulights	each 3-0×9-0	
	Superficial yards	<hr/>
3 coats oil paint in shades on plain cornice, girding about 12"		<hr/> 30-0
3 coats oil paint in shades on doors.....	2 each 4-6×7-0	
3 coats oil paint in shades on 2 doors and faulights	each 4-6×9-0	<hr/>
	Superficial yards	<hr/>
3 coats oil paint in shades on skirting, girth 8" ..	lineal feet	<hr/> 18-0

Staircase and Closs

Size tinting ceiling of staircase.....	17-0× 9-0
Size tinting walls	52-0×40-6
Size tinting newal	19-0×31-0
Size tinting ceilings of landings 3 each.....	9-0×1-0
Size tinting ceiling of closs	20-0× 4-0
Size tinting walls of closs	40-0×10-0
Size tinting walls of closs next back.....	36-0× 9-0

Deduct 3 stair windows.....each	4-6 × 8-0	
8 entrance doors.....each	4-0 × 8-6	
Cement on lower walls of stair and newal, etc.	250-0 × 4-6	_____
	Superficial yards	=====
3 coats oil paint on Portland cement lower		_____
walls	250-0 × 4-6	_____
3 coats oil paint grained imitation oak and 1		_____
coat varnish on 8 entrance doorseach	5-0 × 8-6	_____
3 coats oil paint on outside of 24 windows		_____

ABBREVIATIONS THAT MAY BE USED IN NOTE BOOK

Altn.	for	Alteration	Flt.	for	Fanlight
Addn.	"	Addition	Frt	"	Front
Astrl.	"	Astragal	F. P.	"	Fireplace
Archve.	"	Architrave	Ft.	"	Foot
Abt.	"	About	Feg.	"	Facing
Adjn.	"	Adjoin	Fa.	"	Facia
Agt.	"	Against	Fl.	"	Floor
Bm.	"	Bottom	Frd.	"	Framed
Bk.	"	Back	Fd.	"	Found
Bn.	"	Button	Fltd.	"	Fluted
Br.	"	Brick	Grd.	"	Ground
Blk.	"	Black	Gd.	"	Good
Borlt.	"	Borrowedlight	Gld.	"	Glazed
Brwbd.	"	Browband	Galv.	"	Galvanized
Brs.	"	Brass	Gtg.	"	Grating
Bd.	"	Bound	Gl.	"	Glass
Bdd.	"	Beaded	G. p.	"	Gas pipe
C. i.	"	Cast iron	Hd.	"	Head or hard
Csn.	"	Cistern	Hdwd.	"	Hardwood
Cambd.	"	Cambered	Hl.	"	Heel
Ck.	"	Cock	Hdlt.	"	Headlight
Chk.	"	Check	Hy. p.	"	Heavy pipe
Clk.	"	Cloak	H. d.	"	Hammer dressed
Cld.	"	Cleaned	Hfdrsd.	"	Half-dressed
Chfd.	"	Chamfered	Hn.	"	Hewn
Drsd.	"	Dressed	Hy.	"	Heavy
Drsr.	"	Dresser	Inbd.	"	Inbond
Ded.	"	Deduct	Ingo.	"	Ingoing
Dedn.		Deduction	Intd.	"	Introduced
Dr.	"	Door	Incl.	"	Include
Dble.	"	Double	In.	"	Inch
D. T.	"	Dressed top	Impd.	"	Improved
Diamr.	"	Diameter	Jt.	"	Joint
Digl.	"	Diagonal	Jd.	"	Joined
Dl.	"	Deal	Jst.	"	Joist
Est.	"	Estimate	Jb.	"	Jamb
Ex.	"	Except	Jwbx.	"	Jawbox
Excl.	"	Exclusive	Jb.	"	Jamb
Exct.	"	Excellent	Japd.	"	Japanned
Encl.	"	Enclose	K. p.	"	King post
Entd.	"	Entered	Knd.	"	Knee'd
Enfd.	"	Enforced	Kb.	"	Knob
Elev.	"	Elevator	L.	"	Lintel or lath
Ent.	"	Entrance	Ld.	"	Lead or laid
Fr.	"	Frame	Lvd.	"	Leaved

Lifd.	for	Lifted	R. p.	for	Red pine
Ling.	"	Lining	Retd.	"	Returned
Lvl.	"	Level	Relvd.	"	Relieved
Mr.	"	Miter	Rd.	"	Round or raised
M. P.	"	Mantelpiece	Rdd.	"	Rounded
Mt.	"	Mount	R. p. m.	"	Raised planted mouldings
Mtd.	"	Mounted	Rble.	"	Rubble
Mln.	"	Mullion	Redcd.	"	Reduced
Mdd.	"	Moulded	Recvd.	"	Received
Mdg.	"	Moulding	S. L.	"	Safe lintel
Mdn.	"	Modillion	Scun.	"	Scuncheon
Md.	"	Mould	S. f. a.	"	Single fascia architrave
Mble.	"	Marble	Sidelt.	"	Sidelight
Mvble.	"	Movable	Std.	"	Standard
No.	"	Number	St.	"	Stone
Nted.	"	Noted	Shr.	"	Shutter
Nr.	"	Near	Sctlg.	"	Scantling
Ntchd.	"	Notched	Sk.	"	Sunk or Sink
Numbd.	"	Numbered	Tend.	"	Tenoned
Nt.	"	Neat	Td.	"	Turned
O. P.	"	Oil paint	T. b.	"	Tie beam
Ornt.	"	Ornament	Utl.	"	Utensil
Ornl.	"	Ornamental	U. b.	"	Utensil belting
Outbd.	"	Outbond	Venr.	"	Veneer
Oft.	"	Offset	Ventr.	"	Ventilator
Pt.	"	Paint	Ventn.	"	Ventilation
Pd.	"	Panelled	Verl.	"	Vertical
Pd.	"	Pound or paid	W. p.	"	White pine
Ptd.	"	Painted or pointed	Wrt.	"	Wrought
P'td.	"	Planted	W. p.	"	Wallplate
P'tg.	"	Painting	W. p.	"	Waste pipe
Prtu.	"	Partition	Wl. press	"	Wall press
Petn.	"	Petition	Y. p.	"	Yellow pine
Q. p.	"	Queen post			

1870
1871
1872
1873
1874
1875
1876
1877
1878
1879
1880
1881
1882
1883
1884
1885
1886
1887
1888
1889
1890
1891
1892
1893
1894
1895
1896
1897
1898
1899
1900
1901
1902
1903
1904
1905
1906
1907
1908
1909
1910
1911
1912
1913
1914
1915
1916
1917
1918
1919
1920
1921
1922
1923
1924
1925
1926
1927
1928
1929
1930
1931
1932
1933
1934
1935
1936
1937
1938
1939
1940
1941
1942
1943
1944
1945
1946
1947
1948
1949
1950
1951
1952
1953
1954
1955
1956
1957
1958
1959
1960
1961
1962
1963
1964
1965
1966
1967
1968
1969
1970
1971
1972
1973
1974
1975
1976
1977
1978
1979
1980
1981
1982
1983
1984
1985
1986
1987
1988
1989
1990
1991
1992
1993
1994
1995
1996
1997
1998
1999
2000
2001
2002
2003
2004
2005
2006
2007
2008
2009
2010
2011
2012
2013
2014
2015
2016
2017
2018
2019
2020
2021
2022
2023
2024
2025

PART II

Tables, Rules and Memoranda for Obtaining Quick Results in Measurement of Areas, Solids and Contents

PRACTICAL MEASUREMENT OF GEOMETRICAL AREAS

In the following series of problems it will be shown how to find the area of any geometrical figure, without any calculation whatever, by simply drawing a few lines (only two or three in many cases) and then taking one measurement. The problems are supplemented by notes explaining how to apply the methods to large areas, the final measurements being taken on a suitable scale when the area is being found from scale drawings.

(1) Given any rectangle and one side of another rectangle; to complete the latter so that the two areas may be equal. (See Fig. 1). Only one construction line is necessary to solve this problem.

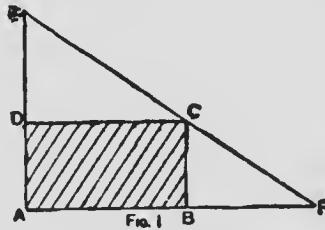

Let $A B C D$ (Fig. 1) be the given rectangle, and $D E$ (marked off on $A D$, produced) the given side of the other rectangle. Join $E C$, and produce it to meet $A B$, produced, in F . Then $B F$ is the other side required to complete the other rectangle.

In other words, the length $B F$ multiplied by the length $D E$ exactly the same result as multiplying $A B$ by $A D$, which, of course, gives the area of the rectangle $A B C D$. A very important use is made of this result in Problem 3. It may be stated that when a terminated straight line is extended or lengthened, this is called "producing" the line, and the line so treated is said to be

"produced."

(2) Given any square and one side of a rectangle; to complete the latter so that the two areas may be equal.

This is identical with Problem 1, since a square

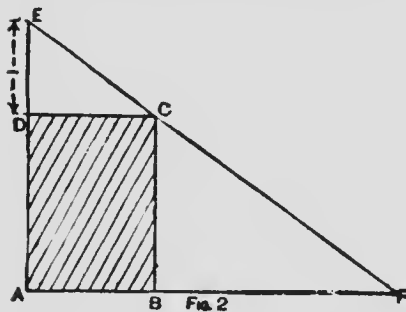

may be considered as a rectangle.

(3) To find the area of any rectangle. (See Fig. 2).

This is a very important problem, since all the areas are reduced to rectangles in this series. Take, as example, the rectangle $A B C D$ (Fig. 2). Produce one side, as $A D$, and mark off $D E$, one inch long. Join $E C$, and produce it to meet $A B$, produced, in F . Then measure $B F$ to obtain the required area—that is, find the number of inches in $B F$ and call them square inches. The reason for this is that the area of the rectangle $A B C D$ is equal to $B F$ times $D E$ (see Problem 1), and $D E$ has been made one inch by construction; therefore the required area equals $B F$ (in inches) times one. Notes—If, by using a line one inch long ($D E$ in Fig. 2), the intersection of lines at F , which denotes the area, become

very oblique and consequently vague, a two-inch line may be used instead at D E, and thus obtain half the area at B F; or D E may be three inches, and B F multiplied by three to find the required area; or D E may be four inches, and B F multiplied by four; and so on. Again, for large surfaces, or in scale drawings, if D E (Fig. 2) is made one foot, the number of feet in B F must be called square feet, it being only necessary to remember, in this case, that any odd inches in the "area line" (B F) do not represent square inches, to obtain which it is

necessary to multiply by twelve. Further, if D E is made one yard, the resulting area will be in square yards, in which case any odd feet

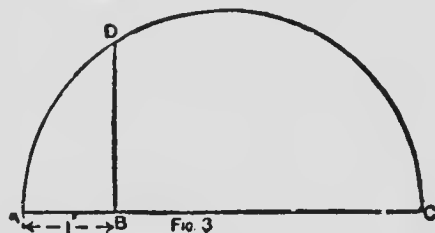

in the "area line" must be multiplied by three to convert them into square feet, and any odd inches by thirty-sixth to convert them into square inches.

(4) To find the area of any square.

This is solved by Problem 3, treating the square merely as a rectangle. Note—In the case of a square, the line B F (Fig. 2) is always the square of A B, and the problem may thus be used to obtain rapidly the square of any awkward number, fractional or otherwise.

(5) To construct a square of any given area. (See Fig. 3.)

Draw a line and mark off on it A B one inch long (see Fig. 3) and B C (in the same direction) equal to the required area—that is, make B C as many inches long

as the area contains square inches; if, for example, the area is to be three and five-sixteenths square inches, make B C three and five-sixteenths inches long. Now describe a semicircle on A C, and at B erect a perpendicular to meet the curve in D. Then B D is the side of square which will contain the given area. Notes—This method does not break down when the area contains awkward fractions, but is quite as easy and correct for fractional areas as for simple cases. A B (Fig. 3) must always be one inch if the area is in square inches. If, however, the area is given in square

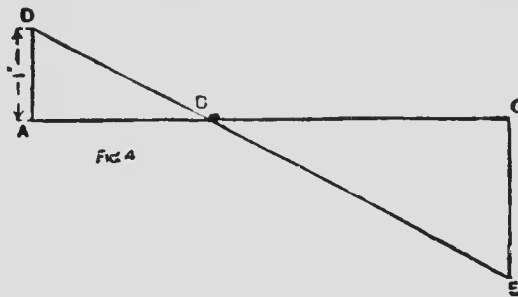

feet, use a line one foot long at A B, and if there are any odd square inches in the area, they must be divided by twelve before being included in the "area line" (B C). Suppose, for example, a square is required containing eight square feet, 102 square inches. Now 102 divided by twelve is eight and one-half; therefore make A B one foot, and B C eight feet, eight and one-half inches. Then B D is the side of the required square. If the area is given in square yards, etc., make A B one yard, and divide the odd feet in area by three and the odd inches by thirty-six.

(6) Given one side of a rectangle; to construct the figure so as to contain any given area. (See Fig. 4).

AB (Fig. 4) is made equal to the given side. Produce it and mark off BC equal to the given area—that is, if the area is to be, say, three and one-quarter square inches, then BC must be made three and one-quarter inches long. Draw perpendiculars at A and C one on each side of the line. Mark off AD on the perpendicular at A equal to one inch. Join DB, and produce it to meet the other perpendicular in E. Then CE is the required side of rectangle. Note—AD must always be placed at the end of the given side, not at the “area” end of the line. AD must always be one inch if the area is given in square inches; if it is given in square feet or square yards, see note to Problem 5.

(7) To find the area of any rhomboid. (See Fig. 5).

Take, as example, the rhomboid ABGH (Fig.

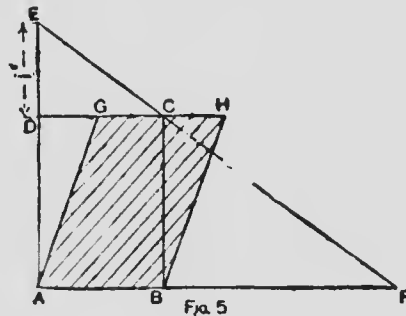

5). From A and B draw perpendiculars to meet GH (or GH produced) in C and D. Then the rectangle ABCD equals in area the rhomboid ABGH. Proceed to find the area of the rectangle, and consequently of the rhomboid, as in Problem 3. DE is made one inch, and then, BF being two and one-half inches, the area of the rhomboid is two and one-half square inches.

(8) To find the area of any rhombus.

Proceed exactly as in Problem 7.

(9) To find the area of any four-sided figure with

two parallel and two non-parallel sides (trapezoid). (See Fig. 6).

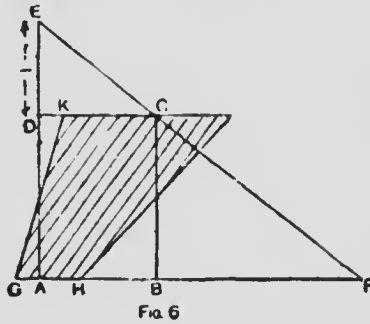

FIG. 6

Through the middle points of the non-parallel sides draw perpendiculars to the parallel sides (or the parallel sides produced), and thus obtain a rectangle equal in area to the trapezoid. In Fig. 6.

(10) To find the area of any triangle. (See Fig. 7.)

Take, as example, the triangle A B C (Fig. 7).

From one angle C draw a perpendicular C D to the opposite side A B; bisect this perpendicular by a line parallel to A B. From A and B draw perpendiculars to meet this bisecting line in E and F. Then the rectangle A B E F equals the triangle A B C in area. Again, by Problem 3, A G being 1 in., F H gives the required area; in this case it is $2\frac{3}{4}$ in. Notes:—Any of the three sides

of a triangle may be taken as "base," according to convenience, and the "altitude" measured perpendicularly from the base to the opposite angle. A rectangle can then be

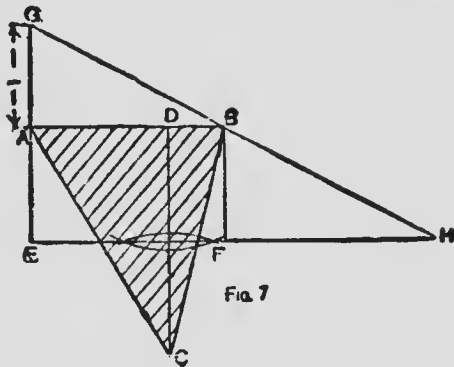

FIG. 7

constructed with the same base and half the altitude, or half the base and the same altitude. In an irregular

triangle, therefore, there are at least six different rectangles, any of which can be used to find its area.

(11) To find the area of any irregular four-sided figure (trapezium). (Fig. 8).

Take, as example, the irregular quadrilateral $A B C D$ (Fig. 8). Draw one diagonal $A C$; draw perpendiculars to this diagonal from the other two angles B and D , and through the middle points E and F of these perpendiculars draw parallels to the diagonal $A C$; and, lastly, through the extremities A and C of the diagonal draw perpendiculars to it to meet these parallels in $G H J K$. Then the rectangle $G H J K$ equals in area the irregular figure $A B C D$. Now proceed by problem 3 to find this area. $K L$ (Fig. 8) measures $2\frac{1}{8}$ in., therefore the area of $A B C D$ is $2\frac{1}{8}$ sq. in.

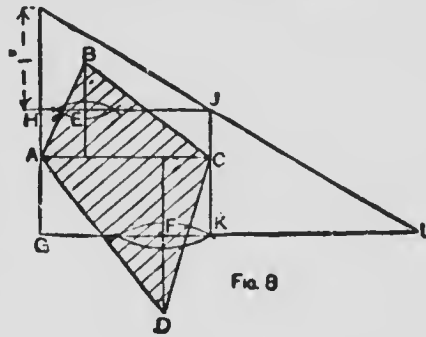

Fig. 8

(12) To find the area of any regular hexagon. (See Fig. 9).

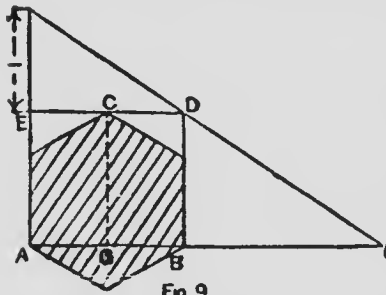

Fig. 9

The hexagon and the octagon (Problem 13, Fig. 10) lend themselves to very neat special solutions; they could, of course, both be treated by the general method for regular polygons

given in Problem 14 (Fig. 11). Let A , B and C

be three alternate angles of the hexagon, as in Fig. 9. Join $A B$ and produce indefinitely. Produce also the two sides which are at right angles to $A B$, as $A E$ and $B D$ (Fig. 9). Through C draw a parallel to $A B$ to meet the two last produced lines in E and D . Then the rectangle $A B D E$ equals the hexagon in area. Again applying Problem 3, $B F$ measures nearly 2 in., and therefore the hexagon in Fig. 9 contains 2 sq. in. nearly. Note:—To find the area of large hexagonal surfaces, simply multiply the two lengths $A B$ and $C G$ (Fig. 9)

together.

(13) To find the area of any regular octagon. (See Fig. 10).

It can be readily shown that in any regular octagon the area of

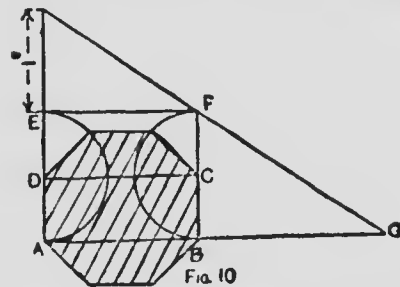

the rectangle made by joining the extremities of two opposite sides is exactly half the area of the octagon, as $A B C D$ (Fig. 10). Hence the following method for finding the area. Produce two opposite sides until their length is doubled; thus $D E$ and $C F$ are made equal to $A D$ and $B C$. Join $E F$, and then the area of the entire rectangle $A B F E$ will equal the area of the octagon. $B G$, obtained by Problem 3, measures $1\frac{7}{8}$ in., consequently the octagon contains $1\frac{7}{8}$ sq. in. Notes:—For large octagonal surfaces multiply twice the length of the side by the direct distance across from side to side. The area of any *even-sided* regular polygon can be found as in Fig. 10 by making $A E$ and $B F$ each equal to a

quarter of the total boundary. For instance, in a duodecagon (twelve sides) AD and BC must be made equal to three sides.

(14) To find the area of any regular polygon. (See Fig. 11.)

Produce one of the sides until the total length equals half the perimeter or boundary (see note at end of Problem 14). In Fig. 11 the polygon (pentagon) has five sides; therefore one side, AB , is extended to C , so that the whole line ABC equals $2\frac{1}{2}$ sides.

Now draw a parallel through O , the center of the figure, to meet perpendiculars from A and B , in E and D . Then the rectangle $ACDE$ again equals the given figure in area. The length of AF , found by Problem 3, is $1\frac{3}{4}$ in.; the area of polygon is therefore $1\frac{3}{4}$ sq. in.

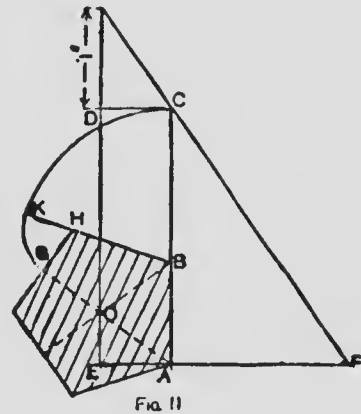

FIG. 11

Notes:—To make BC (Fig. 11) equal to half the boundary, proceed in this way: Mark G the point directly opposite to A . Then with the angle H as center, swing G round until it is in a line with the next side (BH) at K ; then go to the next angle B and swing K round again until in a line with the next side at C , and so on. In Fig. 11 no more swinging round is necessary, but for a greater number of sides the operation must be continued until half the boundary has been unwound, as it were, into a straight line. To find

the center of any regular polygon with an odd number of sides, draw a line from any angle to the middle point of the opposite side; this line contains the center, and if

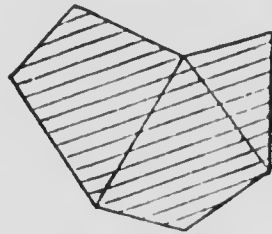

Fig. 12

another angle and side are similarly treated the required center is the intersection of the two lines (dotted in Fig. 11). Of course, if the number of sides is even, simply join opposite corners twice.

(15) To find the area of any irregular figure with more than four sides (See Fig. 12).

If the number of sides is even, divide the area into quadrilaterals, and find the area of each quadrilateral as in Problem 11, and then add these areas; if odd, divide it into quadrilaterals and one triangle, as indicated by dotted lines in Fig. 12; treat the former by Problem 11 and the latter by Problem 10. This method is far less confusing and consequently more reliable than reducing the whole figure to one triangle equal to it in area (on the principle of triangles of equal base and altitude being equal). Moreover, the results will be more correct in the long run.

(16) To find the area of any circle. (See Fig. 13).

On the diameter A B (Fig. 13) construct an equilateral triangle A B C; produce the sides C A and C B to meet the tangent drawn parallel to the diameter, A B, in D and E;

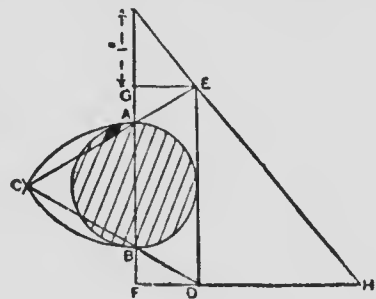

Fig. 13

from D and E draw perpendiculars to meet the diameter produced in F and G. Then the rectangle F D E G equals the circle in area (see note), and D H equals area of circle in square inches as before. Note: The length D E (Fig. 13) is generally accepted in staircase work, handrailing, etc., as being equal to half the circumference of the circle. As a matter of fact, half the circumference equals 3.141592, etc., times the radius of the circle, while the length B C equals 3.154705, etc., times the radius, showing an error of .013113 too much; so that the results obtained by the preceding method are a little over 2-5 per cent in excess of the actual areas, or an excess of .00416 in. (about 1-250 in.) to every square inch. This will be near enough for most practical purposes, but where greater accuracy is required the foregoing figures are taken in order that the excess may be subtracted from the result obtained.

(17) To find the area of any sector of a circle. (See Fig. 14).

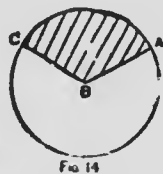

FIG. 14

The most practical method of solving this problem is to find what part of the whole circle the sector A B C (Fig. 14) represents; this can be done by measuring the angle A B C and comparing it with 360° . For instance, 30° is one-twelfth of 360° ; 36° , one-tenth; 40° , one-ninth; 45° , one-eighth; 60° , one-sixth, $67\frac{1}{2}^\circ$, three-sixteenths, etc. In Fig. 14 the angle is 120° , or one-third of 360° . Now construct a rectangle equal to the whole circle by Problem 16 (Fig. 13), and then take off the part required. In the case given in Fig. 14 it will be neces-

sary, after obtaining the rectangle for the whole circle, to take one-third of the rectangle as the required area of the sector A B C.

(18) To find the area of any segment of a circle. (See Fig. 15).



When the segment A B C is less than a semi-circle, as in Fig. 15, find the area of the whole sector A B C D, of which it forms a part, as in Problem 17, and then subtract the area of the triangle A B D, which is found by Problem 10. If the segment is more than a semi-circle, find the area of the whole circle as in Problem 16, and then subtract the small segment not required.

(19) To find the area of any surface bounded by straight lines and circular arcs. (See Fig. 16).

Join the extremities of the arcs to the centers from which they are struck when these centers are within the limits of the area being measured; when the centers are outside the area simply cut off the arcs by their respective chords. Then treat the separate portions as an irregular polygon (by Problem 15), and sectors or segments of circles (by Problems 17 and 18). Suppose, for instance, such an area as shown shaded in Fig. 16 is to be measured.

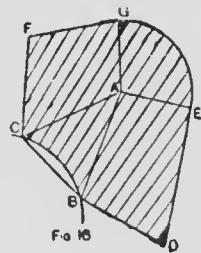

A is the center of the circular corner. The area of the segment on BC is at first included for convenience, and the area of the whole triangle A B C (found by Problem 10) is added to the areas of quadrilaterals A B D E and A C F G (found by Problem 11) and the area of the sector

A E G (found by Problem 17). Finally, the segment B C (found by Problem 18) is subtracted. It is possible by a little manipulation to treat any area in a similar manner.

(20) To find the area of any ellipse. (See Fig. 17).

On one side of the minor axis A B (Fig. 17) describe a semi-circle A B D, and on the other side construct an equilateral triangle A B C; tangent to the semi-circle draw F G, parallel to the minor axis A B, and on the same side of the latter another parallel through the vortex H of the ellipse; produce the sides C B and C A of the equilateral triangle to meet the tangent to the semi-circle

in F and G; through F and G draw perpendiculars to meet the minor axis produced, and the parallel through the vertex in J, K, L and M. Then the area of the rectangle J K L M equals the area of the ellipse

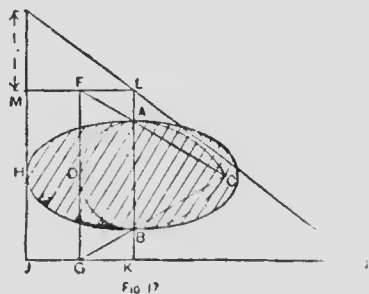

subject to the slight discrepancy referred to in the note at the foot of Problem 16. Therefore, to find the area of the ellipse find the area of this rectangle K M by the method shown in Problem 3.

(21) To find the difference between any two geometrical areas.

Represent each area by a single line as shown in the preceding problems, and then apply the "area lines" one over the other to discover their difference.

(22) To reduce any geometrical area to a triangle of equal area.

Reduce the area to a rectangle by the preceding problems, then give the triangle the same base and twice the altitude of the rectangle, or twice the base and the same altitude.

(23) To reduce any geometrical area to a square of equal area. (See Fig. 18).

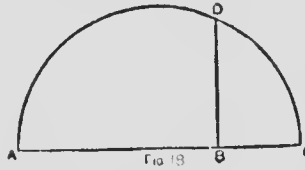

Reduce the area to a rectangle by the preceding problems. Then draw a line and mark A B equal to the long side and B C equal to

the short side of the rectangle (see Fig. 18) Describe a semi-circle on A C, and at the juncture B of the two sides raise a perpendicular to meet the semi-circle in D. This perpendicular B D is the side of the required square.

ABSTRACTING

In abstracting, the items (amount and description) are taken from the dimension sheets, and arranged in the proper order in which they will afterwards appear in the bill. It is usual to abstract one trade at a time, commencing each on a separate sheet of paper, headed with the name of the trade. Leave plenty of room between the items on the abstract paper, as crowding leads to confusion and mistakes.

A general method in abstracting, in each trade, is to take the cubic items first, the superficial items next, then the items measured "run," and finally the numbers, beginning in each case with the items of least value. Each item as it is abstracted, is crossed through with a vertical line |, and when all the items have been taken from a single dimension sheet a tick is placed at the bottom.

In taking the description of items from the dimension sheet, they should be faithfully copied without alteration, except when extremely long, in which case a portion only may be written with a reference back added (as "etc., in sheet"). The abstract should be checked by a second person, who ticks the items on the dimension sheet and abstract in red ink as he proceeds.

After all the items have been abstracted, each class should be totalled, the deductions subtracted, the averag-

ing done if required, and the resulting figures are those to transfer to the bill.

Excavator.—Abstract in order all excavations, afterwards taking the concrete, etc. To reduce feet to yards, divide superficial items by 9, and cubic items by 27.

Drainage.—Commence with the smallest sized drain, first taking the item requiring the least excavation; follow in order with other depths and larger drains.

Bricklayer.—Make four columns, as under :—

1 brick wall.	1½ brick wall.	Deductions.	
		1 B.W.	1½ B.W.
84	84		
62	62		
	48		
	24		

and abstract in these, walls of any thickness, *c. g.* 84 feet superficial of 1 or 1½ brick wall would be put in their respective columns, while 62 feet of 2½ brick wall would be abstracted as 62 feet of 1 brick wall and 62 feet of 1½ brick wall.

If 48 feet superficial of 2¼ brick wall had to be abstracted it would appear in the 1½ brick column as 48 feet, and again as 24 feet. The first item of 48 feet equals 1½ brick thick, leaving 48 feet of ¾ brick wall to be abstracted, which is done by halving the amount, thus obtaining 24 feet of 1½ brickwork, which is equal to 48 feet of ¾ wall.

All other thickness walls could be abstracted in one or other of the columns by proceeding in the same way.

When all brickwork is abstracted, total the columns, subtract the deductions, reduce the 1 brick wall to 1½

brickwork by deducting, $\frac{1}{3}$, then reduce the $1\frac{1}{2}$ work to rods by dividing it by 272.

Facings and other items will follow.

Mason.—Separate the different kinds of stone, with their labors.

Tiler or Slater.—Take chief item of slating or tiling first, dividing total amount by 100 to reduce to squares.

Carpenter.—Abstract in the usual way, taking cubic items first, following with the superficial, runs, numbers, and, lastly, any "fixings only" to ironwork. In the runs take the smallest sized pieces first, as 2×3 , then 3×4 , and so on.

Joiner and Hardware.—Separate the various kinds of wood, first taking all the pine. Commence with floors, dividing by 100 to obtain the number of squares, then skirting, sashes and frames, doors, framings, sundries and lastly stairs. Follow with the hard woods, as mahogany, teak, oak, etc., finally the hardware and fixing.

Iron-Work.—Take wrought iron first, the cast iron afterwards, bringing all to weight in cwts. Wrought iron and rolled iron weigh 480 lbs., and cast iron 450 lbs., per cubic foot. Consequently 1 foot superficial of 1" thickness wrought iron would weigh 40 lbs., and cast iron $37\frac{1}{2}$ lbs. Provide columns for various thicknesses of iron to be abstracted, and having totalled each, reduce all to their equivalent in 1" iron; then multiply by 40 or $37\frac{1}{2}$ for W. or C. I.

Plasterer.—Take plastering to ceiling and walls first, afterwards the cement work. Divide by 9 to reduce to yards superficial.

Plumber.—Include in one item all lead in flats, gutters, and flashings (but lead in secret gutters and stepped flashings would be abstracted together to form another item). Make columns for 4-lb., 5-lb., 6-lb., and 7-lb. lead, under which enter the various squared dimensions; multiply the totals by 4, 5, 6, or 7 respectively, and add the same together. This gives the total weight in lbs., which is then reduced to cwts.

Take all labors after the lead, and follow with the internal work, as pipes, W. C.'s, baths, etc.

Gasfitter.—Pipes, beginning with the smallest, afterwards the fittings, etc.

Hot-water Engineer.—The same order would apply as for "Gasfitter."

Bellhanger.—Bells first, and sundries afterwards.

Painter.—Superficial items first, dividing by 9 to reduce to yards; then the "runs" and numbers.

Glazier.—Take glass of least value first, arranging the squares in their order of "under 2 feet," etc., commencing with the smallest. After glass, abstract any labor to that glass before proceeding to another variety.

Paperhanger.—Although a piece of English paper is supposed to be 12 yards in length, it is seldom found to measure more than 11 yards; the width is 21", consequently a piece contains about 58' superficial. Abstract the items, add $\frac{1}{4}$ to allow for waste in matching pattern, etc., then divide by 58, which gives the number of pieces; any amount over a piece to be counted as a full piece. American and French papers only measure 18" wide, and are about 9 yards long, containing $40\frac{1}{2}'$ superficial;

therefore to obtain the number of pieces divide by 40 instead of 58.

The totals of abstract on completion should be checked by a second person, in order to avoid mistakes being inadvertently made and to ensure that everything is correct.

EXAMPLES OF ABSTRACTING

The dimensions shown are obtained from the examples previously taken off.

EXCAVATOR

cube.
Ex. and cart away.

2092 9	Ddt.
671 0	585 11
<hr/>	
2763 9	
585 11 D.	
<hr/>	
27)2177 10	
<hr/>	
80 $\frac{2}{7}$ yards.	

Ex. R.F. and R.

27)585 11	
<hr/>	
21 $\frac{3}{7}$ yards.	

Ex. to basement trenches,
part R.F. and R.

27)218 2	
<hr/>	
8 $\frac{2}{7}$ yards.	

Ex. to basement trenches,
and cart away.

27)290 10	
<hr/>	
10 $\frac{5}{7}$ yards.	

Ex. to surface trenches,
part R.F. and R.

27)101 0	
<hr/>	
3 $\frac{7}{7}$ yards.	

cube.
Ex. to surface trenches
and cart away.

27)50 6	
<hr/>	
1 $\frac{6}{7}$ yards.	

Brick core filling,
rammed and levelled.

27)12 0	
<hr/>	
1 $\frac{2}{7}$ yards.	

sup.
Remove top soil 6" deep, wheel
and spread where directed.

380 6	
122 0	
<hr/>	
9)502 6	
<hr/>	
55 $\frac{3}{7}$ yards.	

cube.
Concrete in trenches,
6 ball: t to 1 P. cement.

290 10	
50 6	
<hr/>	
27)341 4	
<hr/>	
12 $\frac{4}{7}$ yards.	

sup.
6" concrete AB levelled top.

226 4	
69 0	
<hr/>	
9)295 4	
<hr/>	
32 $\frac{4}{7}$ yards.	

No.
Cement concrete over trim
mers, levelled up for hearths.

<hr/>	
2	

DRAINAGE

run.
4" glazed stoneware drain,
jointed in cement and dig-
ging av.3'3", and 6" cement
con rete under and around
pipes.

46 3

4" drain AB laid in tunnel,
including strutting,

6 0

4" drain AB and digging av.
6' in road

10 0

4" drain and digging for
air inlet.

7 0

Nos.

Extra to 4" bends.

2

1

3

E. to intercepting trap with in-
specting arm and stopper, in-
cluding extra digging, con-
crete and bedding in cement

1

Nos.

Bull-nose slipper trap and
channel with 4" outlet and
galv. iron grating.

1

Connect to sewer, including
eye.

1

Connect to 4" trap.

1

Connect to 4"
soil pipe.

1

run.
1" galv R.W. pipe
3 0

No.

Galv. iron mica flap air inlet
for 4" pipe.

1

Connect R.W. pipe to drain
and air inlet.

2

Provide lighting and watching

Pay all fees to local authorities.

Following in small quantities
to inspection chambers.

cube.

Ex. and cart away.

80 10 Ddt.

152 9 40 4

53 10 76 2

287 5 116 6

116 6D.

27)170 11

6 $\frac{2}{3}$ yards.

Ex. R.F. and R.

40 4

76 2

27)116 6

4 $\frac{2}{3}$ yards.

Concrete of 6 of ballast
to 1 of cement.

27)53 10

2 yards.

sup.		run.	
Reduced brickwork in mortar.		4" white glazed channel pipes, bedded and jointed in cement.	
1 B.	1½ B.	6 0	
14 0	7 0	No	
21 0	57 8	4" long channel bends.	
49 0	64 8	2	
2 6		Cement concrete bolstering 3'0"×2'6", average thickness 4½", laid to falls, trowelled top and made good to chan- nels	
86 6		2	
Ddt. ¼ = 28 10		C.1. air-tight covers and frames, 30"×24" with grease joint, fixing and bedding in cement.	
57 8		2	
E. only in cement.		Make good drain to 1 B.W.	
1½ B.		5	
61 8		1	
run.		6	
E. labor oversail courses.			
41 0			
9" average trowelled cement skirting.			
22 0			
No.			
Mitres.			
8			

BRICKLAYER

sup.				Extra only in cement.	
Reduced brickwork in mortar.				1 B.	1½ B.
1 B.	1½ B.	Deduct		7 10	7 10
41 7	41 7	1 B.	1½ B.	Ddt. ¼ 2 7	5 3
3 1	111 0	10 6	23 7	5 3	13 1
3 10	555 0	24 9	11 0	Half B.W. in cement.	
10 1	3 1	16 6	9 6	20 3	
2 0	1 11	43 1	44 1	2 2	
94 6	4 9	23 7		22 5	
172 2	47 3	47 2		2 courses slates in cement damp course.	
10 8	764 7	165 7		64 9	
135 0	44 1			Asphalte damp course.	
38 6	720 6			5 0	
86 8	292 1			4 6	
5 7	1012 7			9 6	
603 8					
165 7	272)1012 7				
438 1		3 r. 197'			
146 0	Ddt. ¼				
292 1					

sup.
 Coach hd. trimmer arch
½ B. in cement.
 19 0

Rough cutting, straight
 3 4

Ditto, circular.
 15 0
7 0
 22 0

run.
1½ rough cutting.
 12 0

Rake out and point flashings
 in cement.
 88 0

Nos.
 Extra labor and waste to
 relieving arches.
 1 Bk. by 1 Bk.
 3-3'8"

Extra labor, cutting and waste
 to relieving arches.
 1= 4' 6" × 9" × 9"
 1= 3' 0" × 9" × 4½"
 1= 3' 0" × 9" × 4½"
 1= 4' 6" × 9" × 18"
4= 15' 0" × 3' × 3'
 Average 3' 9" × 9" × 9"

Terra-cotta chimney-pots 2'
 high, set and flanchied in
 cement.
4

Nos.
 Tile hearths P.C. 20/- and
 setting.
2

Extra to Breeze fixing bricks.
 18
 8
26

26" × 16" × 5" white glazed
 stoneware sink and fixing.
 1
 Bed and point frames.
 3

Perforate and make good
1½ B.W. to lead pipes.
 1
2
 1 ditto in 2 B.W.
 1
4
 1
 1
 6

Build in ends of timbers.
 6
 10
16

Parge and core flues.
 4

Set stove, 3' opening.
 2

Set kitchener, 4'6" opening,
 and all firebricks and lumps.
 1

9" × 6" air grids, fixing, and
 channels in 1½ B.W.
 6

No.
 9" × 6" plain iron outlet venti-
 lator and fixing.
1

FACINGS

	sup.		run.
E. on stock B.W. for first qual reds, finished with struck joint.			4" fair cutting, straight.
	199 10	Ddt.	6 6
	8 3	33 0	
	5 3	21 0	Cement idlet
	70 10	9 9	15 0
	12 5	63 9	
	296 7		
	63 9		
	232 10		
			1 on facings to oversailing courses
			15 0
			49 6
			61 6
E. on stock B.W. for ganged arches in red rubbers, set in lime putty and grouted in P. cement.			
	9 9		Make good facings to ends of sills.
	3 9		6
	13 6		

MASON

LIMESTONE

	cube.		Plain work rubbed.
Stone and setting.			
	1 4		1 0
	2 3		1 4
	2 10		1 7
	6 5		3 11
	sup.		Sunk work rubbed.
Half sawing.			
	2 1		4 0
	2 3		1 7
	4 7		5 7
Beds and joints, one face for two.			
	4	Half bed.	sup.
1 7	4 0	Ddt.	Sunk work rubbed, stoppe l.
6	3 0 D.	3 0	3 0
2 3	2 1 0		
11	6		
2			
6			
9 1			Moulded work
			2 7

run.
<u>Throating.</u>
4 0
4 9
<u>8 9</u>

<u>1" x 1" groove.</u>
4 9
No.
<u>Form stools</u>
<u>2</u>

SANDSTONE

sup.
<u>2" rubbed heartl.</u>
8 7
8 3
<u>16 10</u>

No.
<u>Notches.</u>
2
<u>12" x 10" x 6 tooled templates.</u>
<u>6</u>

TILER

sup.
Best Red tiling on sawn fir
laths, to 3½" gauge, fixed with
galv. nails.

<u>437 6</u>
32 0
22 6
8 9
<u>500 0 = 5 sqrs. 9 ft.</u>

run.
Bedding verge in cement.

17 6

Bedding eaves course in cement.

64 0

run.
Extra to plain hip tiles,
bedded in cement.

22 6

No.
Intersection hips and ridge
to finial.

1

Plain ridge bedded and
jointed in cement.

18 0

Extra to finial P. C. %, add carriage and fix.

1

No.
Fair end.

1

Hip hooks.

2

SLATER

sup.		run.
Blue Bangor Countess slating, 3" lap, centre nailed with compo. nails, 2 to each slate.		Slate ridge 2½" roll, 7" wings, bed and joint in cement.
		20 3
714 0	Ddt.	
35 0	7 0	No.
15 5	25 0	Fitted ends.
764 5	32 0	2
32 0 D.		
732 5		Make good around 1" exhaust pipe.
=7 sqrs. 32 ft.		1

CARPENTER

cube.	
Spruce in plates and lintels.	Spruce framed in 3 roof trusses, hoisting and fixing 35 ft. above ground level.
1 8	16 3
9	7 5
1 11	2 10
1 8	3 8
6 0	30 2
Spruce framed in floors.	
15 9	
7 0	
1 11	
10 8	
35 4	
Spruce framed in trussed partition.	cube. Spruce framed in roofs.
10 9	26 9
4 0	28 8
4 6	5 1
1 9	42 0
2 4	102 6
7	
1 2	sup.
1 7	1" rough boarding, edges shot, to roof.
1 4	846 8
11	8 sqrs. 46 ft.
4 10	
1 7	1" rough board in gutters and 2" × 2" bearers, 15" apart.
1 10	80 0
36 11	

run.
 $2" \times 1\frac{1}{2}"$ H. B. strutting to
9" joist.
 26 6

$4\frac{1}{2}" \times 2"$ nogging pieces.
11 8

Springing piece for trimmer.
12 0

$2" \times 1"$ tilting fillet.
80 0

$3" \times 3\frac{1}{4}"$ ditto.
80 0

$1\frac{1}{2}" \times 9"$ rough board, spiked
 to wall.
80 0

run.
2" ridge roll.
 40 0

Labor in splayed edge to
1" roof boarding.
 100 0

Nos.
 Labor in scarf to $6" \times 8"$ purlins
 including bolts.
2

Ditto to $4" \times 11"$ pole plates.
2

Cleats.
 $4" \times 4" \times 2"$ shaped.
 6

Ditto $9" \times 4" \times 4"$ shaped
6

Extra to form $12" \times 12" \times 6"$ dove
 tailed cesspools, holes
 disaed. and fitted.
4

Nos.
 Extra to form $2"$ rebated drips
8

$1\frac{1}{2}"$ roll in gutter.
2

run.
 $4\frac{1}{2}"$ turning pieces.
 9 0

sup.
 Use and waste of centering
 for trimmer.
18 0

Nos.
 Fixings only to bolts.
 4 11" = 44"
 35 6" = 210
 6 13" = 78
 21 6" = 126
 66 66)458
 7" average

Fixings to strans.
13
6
 19

JOINER AND HARDWARE

FLOORS

sup.		
1¼" yel. batten, edges shot, grooved and gald. iron tongues, splayed headings and fixed with 2½" brads.		Ditto, including bearers. In small quantities.
		<u>5 4</u>
	175 7	run.
	11 3 D.	E. O. 3½" × 5s" oak border, in- cluding reb. floor, glueing and mitreing.
	164 4	<u>8 7</u>
=1 sq. 64 ft.	Ddt. 4 6	
	6 9	
	11 3	

SKIRTINGS

run.		Nos.
1" × 8" torus mould, scribed, in- cluding backings and splayed grounds plugged to wall.		External mitres.
		<u>2</u>
	46 9	Internal ditto.
	8 0 D.	6
	38 9	<u>Fitted ends.</u>
		2
		<u>Housings.</u>
		2

DOORS

sup.	
2" 6-pan., planted mouldings both sides, double tenoned for mortise locks.	<u>21 0</u>

SASHES AND FRAMES

sup.	rim.
Cased frame and 2" sashes (description).	Labor in hook joint.
<u>22 0</u>	<u>6 6</u>
	Labor in reb. and circular tongue.
2" ovolo casements.	<u>13 0</u>
26 0	
	Labor in reb. and splayed bottom rail.
2" ovolo fanlight.	<u>3 10</u>
7 8	

$3\frac{1}{2}'' \times 1\frac{1}{2}''$ moulded and grooved
weather-board
3 9

Labor groove in oak.
3 9

Nos.	
Mouldings for glass and mitres.	
Sets.	
4	9' = 36'
1	10 = 10
5	5)46
	average 9' 3"

THICKNESSES AND FRAMINGS

sup.
7/8" W.O.S. moulded grounds,
splayed edge.
9 3

1" rough framed grounds,
O.E.S., one edge splayed.
12 7

1 1/4" window-board reb. and
moulded, and all bearers.
2 10

No.
Notched and return mould.
ends.
2

sup.
1 1/2" jamb lining W.O.S.
framed, 2 ce reb. pan, plant
mouldings and dovetail
backings.
28 10

run.
3" x 7/8" elbow linings, reb. 1
edge, tongued angles and
backings.
14 11

Labor to groove.
14 11

Labor to groove in oak.
3 9

run.
4 1/2" x 3 1/2" framed, wrot. sunk-
weathered, rebated, 3 times
moulded and throated in
transom.
4 6

4 1/2" x 4 1/2" 2 ce moulded, re-
bated, and hollow grooved
jambs.
13 5

4 1/2" x 4 1/2" 2 ce moulded and
rebated head.
4 6

IN OAK

run.
6" x 3" framed, rebated, weathered and 2 ce grooved in sill.
4 6

IN MAHOGANY

No.
1 1/4" best quality W. C. seat and cover, with brass side hinges.
1

MOULDINGS AND SUNDRIES

run. 2" x 1 1/2" bed moulding, rebated. <u>47</u>	9" x 6" x 2 1/2" cham. plinth blocks. <u>4</u>
No. Return and moulded ends. <u>2</u>	Frame architrave to plinth block. <u>4</u>
run. 4" x 2" moulded architrave. <u>171</u>	Housings in plinth blocks. <u>4</u>
5 1/2" x 2" ditto. <u>378</u>	Holes in frame for saddle-bar. <u>2</u>
No. Mitres. <u>2</u> <u>4</u> <u>6</u>	run. Labor to groove. <u>47</u>
	Allow for attendance by joiner on plumber. <u> </u>

IRONMONGERY AND FIXING

Nos. Pairs 3 1/2" W.I. butts. <u>1 1/2</u>	3" solid brass sash fastening. <u>1</u>
Nos. Pairs 3" brass butts. <u>2</u> <u>1</u> <u>3</u>	3" brass flush sash lifts. <u>2</u>
6" 2-bolt 4-lever mortise lock, P. C. 9/8, brass reeded furni- ture. <u>1</u>	4" brass sash pulls. <u>2</u>
Sets, brass-reeded finger-plates. <u>2</u>	Fanlight opener, P.C. 17/6. <u>1</u>
	Brass Escabelette bolt for 6' 6" casement. <u>1</u>

<p>Brass cups and screws. <u>12</u></p> <p>Brackets for W.C., 16½" high. Pair. <u>1</u></p>	<p style="text-align: right;">run.</p> <p>1¼" × ¼" galld. water-bar. bedded in white lead. <u>39</u> <u>46</u> 83</p>
---	---

SMITH AND FOUNDER

WROUGHT IRON

In 1 plate girder and hoisting and fixing 16 feet above ground level.

sup. ½".	sup. ⅜".	sup. ¼".	sup. 1" collected.
174	141	15	250
260		4¼ of 1".	5 3⅜
50	5 3⅜ of 1".		<u>4¼</u>
18			30 7⅝
<u>500</u>			<u>40</u>
=250 of 1"			1226 lbs.
		Rivets 5% =	<u>61</u>
			<u>1287 lbs.</u>

STRAPS

2" × ⅜".	2" × 5/16".	1½" × 5/16".	sup. 1" collected.
2311	130	210	210½
311	2	<u>1½</u>	16
120	2 2 sup. of 5/16"	27½	4 4½
64	<u>27½</u>		<u>40</u>
462	4 9½ of 5/16"		175 lbs.
2			
7 8 sup. of ⅜" = 16 of 1"			
=210½ of 1"			

CHIMNEY-BARS CAMBERED AND CAULKED

2½" × ½".	2" × ⅜".	sup. 1" collected.
64	48	12
<u>48</u>	2	3⅜
110	9	15⅝
2½	=3⅜ of 1".	<u>40</u>
2 3½ sup. of ½".		57 lbs.
= 12 of 1".		

BOLTS

(FIXING TAKEN IN "CARPENTER")

Nos.	No.
$\frac{3}{4}$ " , 11" long, sqr. heads, nuts and washers.	$\frac{1}{2}$ " , 6" long bolts A. B.
4	35
	21
	56
Sets of gibs and cotters.	run.
3	
$\frac{1}{2}$ " , 13" long, sqr. heads, nuts and washers.	$\frac{1}{2}$ " round gald. iron saddle.
6	37

CAST IRON

In 1 hollow column fixed at ground-level.

sup. $1\frac{1}{4}$ ".	sup. $1\frac{1}{2}$ ".	sup. 1".	sup. 1" collected.
15 9	2 0	4	27 $6\frac{3}{4}$
	3		4 3
=27 $6\frac{3}{4}$ of 1"	7		4
	2 10		32 $1\frac{3}{4}$
	=43 of 1".		37 $\frac{1}{2}$
			1205 lbs.
			Feathers $2\frac{1}{2}$ " 30
			1235 lbs.

No.	Nos.
<u>Pattern for column.</u>	<u>Extra to 2" shoe.</u>
1	1
run.	
<u>2" R.W. pipe and fixing.</u>	<u>2" R.W. head.</u>
10 0	1

PLASTERER

sup.
L. P. F. and S. ceilings.
208 0 Ddt.
4 6 D. 4 6
9)203 6
22 $\frac{2}{3}$ yards.

L. P. F. and S. partitions.
282 9 Ddt.
18 9 D. 18 9
9)264 0
29 $\frac{1}{3}$ yards.

R. F. and S. walls.
297 4 Ddt.
100 3 D 38 6
9)197 1 6 9
21 $\frac{2}{3}$ yards. 55 0
100 3

sup.
Pl. mold. cornice.
67 8

Nos.
I. Mitres.
5

Ext. Mitres.
2
run.

Keene's cement angle.
18 2

PLUMBER

EXTERNAL

Milled lead and labor in flats, gutters, and flashings.

sup. 5-lb.	sup. 6-lb.	sup. 7-lb.	Ddt.
<u>56 2</u>	10 9	493 9	<u>21 0</u>
5	136 10	6 2	
<u>280</u>	147 7	499 11	
885	6	21 0	
<u>3353</u>	885	478 11	
4518		7	
		<u>3253</u>	
run. <u>Lead wedging.</u>		run. <u>Copper nailing open.</u>	
88 0		16 6	

Nos. Labor to dress angles around curb. <u>4</u>	Extra lead, labor, and solder in cesspools. <u>4</u>
Labor in bossed ends to rolls. <u>28</u>	4" socket pipes 2 ft. long, double bent out of 7-lb. lead, and joint. <u>4</u>
Labor in four-way intersections. <u>13</u>	Donical wire covers to cesspools. <u>4</u>

INTERNAL

run. $\frac{3}{4}$ " strong lead pipe and digging trench. <u>25 0</u>	$\frac{3}{4}$ " ditto and soldered joint. <u>1</u>
$\frac{3}{4}$ " inch strong lead pipe, in- cluding bends, joints and fixing. <u>51 6</u> <u>17 0</u> <u>6 0</u> <u>74 6</u>	$\frac{3}{4}$ " ditto and 2 joints. <u>1</u>
1" lead pipe, etc. <u>11 0</u>	Extra to trumpet-mouth con- nection to grating (sink). <u>1</u>
run. <u>1$\frac{1}{4}$" ditto.</u> <u>9 6</u> <u>3 5</u> <u>12 11</u>	$\frac{3}{4}$ " boiler screws and joints. <u>2</u>
<u>1$\frac{1}{2}$" ditto.</u> <u>4 6</u>	$\frac{1}{2}$ " union and joint. <u>1</u>
Nos. $\frac{3}{4}$ " soldered branch joint. <u>1</u>	1" brass bath overflow grating, union and joint. <u>1</u>
$\frac{3}{4}$ " pipe short lengths. <u>1</u>	1 $\frac{1}{4}$ " brass combined bath waste and trap, cleansing screw, and plug and joint. <u>1</u>
	Nos. <u>1$\frac{1}{2}$" brass clips.</u> <u>2</u>

3" <u>brass grating (sink).</u> 1	Earthenware wash-down pedestal closet and trap in one piece and fixing. 1
$\frac{3}{4}$ " H.P., S.D., stop-cock and joints. 1	Joint W.C. to flush pipe and I.R. cone. 1
$\frac{3}{4}$ " H.P., S.D. bib valve and boss. 1	run.
$\frac{3}{4}$ " copper ball valve, boss, and soldered joint. 1	4" lead soil pipe out of 7-lb. lead, including joints, tacks, and fixing to wall. 27 11
$1\frac{1}{4}$ " lead S trap, screw cap and joints. 1	Nos. Extra to junction bend and joint. 1
Gald. W.I. riveted cistern, 14 B.W.G., 80 galls., and fixing. 1	Joint between W.C. trap and 4" lead soil pipe, including brass collar. 1
Drill holes. 4	
5 ft. C.I. porcelain bath, rolled top, enamelled, and combined hot and cold brass bath valve and joints. 1	Connect soil pipe to drain, including brass thimble. 1
Drill hole. 1	Domical copper wire cover. 1
2 gall. W.W.P. cistern, brass chain and pull. 1	Connect with water company's main, including ferrule, paying fees, and making good road. 1
Nos. Gald. iron bracelets. Pair. 1	Stop-cock and box. 1

HOT-WATER ENGINEER.

run. <u>¾" steam pipe.</u> 9 9	Nos. <u>Drill holes and connections.</u> 4
<u>1" ditto.</u> 5 6	<u>1½" brass unions.</u> 2
<u>1½" ditto.</u> 41 9	<u>1" ditto.</u> 1
Nos. <u>¾" bends.</u> 1 1 2	<u>¾" ditto.</u> 1
<u>1½" ditto.</u> 6	¾" S. O. bib valve, engraved "HOT", and joint to iron pipe. 1
<u>¾" elbow.</u> 1	12"×10" W. welded arched H.P. Boiler. 1
<u>1½"×¾" tee.</u> 1 1 2	Drill holes and connect. In- clude short lengths pipe, back- nuts and joints. 2
<u>Short length ¾" pipe.</u> 1	¾" dead-weight safety valve and joint to iron. 1
Gald. W.I. tank 1" plate bars, with manhole, 30 galls., bear- ers and fixing. 1	Allow for attendance in cutting away and making good after hot-water engineer and test system at completion.

PAINTER

sup.
K.P.S. and 3 on woodwork
and 1₆

42 0
28 10
23 6
3 9
14 2
4 0
1 7
117 10
1₆ = 19 7₂
9)137 6
152₀ yards.

run.
On skirting.
46 9

Nos
On sash sheets very large.
4
1/3 doz.

Sash squares, very large.
8
2/3 doz.

On fanlights.
2

On sash frames, ordinary.
2

Casement frames, very large.
2

On plinth blocks.
4

GLAZIER

sup.
21-oz. sheet glass in squares,
from 6' to 8' super., and
glazing.
12 10

1/4" pol. plate in squares, 4' to 6'
sup., bedded in chamois
leather.
18 6

sup.
Stout lead quarry lights,
with rolled cathedral plate
(selected tints), copper ties,
and axing.
5 10

PAPERHANGER

Paper, price 50c per piece, and
hanging to ceiling.
208 0 Ddt.
4 6 D. 4 6
203 6
1/7 = 29 0
58)232
4 pieces.

Paper, price 75c per piece, and
hanging to walls.
297 4 Ddt.
282 9 38 6
580 1 6 9
64 0 P. 18 9
516 1 64 0
1/7 = 73
58)589
10 pieces 9 ft.

BILLING

BILLING is the operation involved in transferring the totals of the various items from the abstract to the bill form, in order to enable them to be priced, and to obtain an estimate of the cost of the intended work.

The order of billing should follow the order of abstract, if that has been prepared as before explained.

In large contracts each trade should have a separate bill, which should be headed with its name and number. In smaller works all the trades are included in one bill.

It is usual to give a description of the material to be employed by each trade at the heading of its bill before taking the items, the total estimated amount of which is carried to a summary placed at the conclusion of the bill.

A bill form is ruled as under:—

Amount of item.	of	cube, sup or run	Description of item.	\$
-----------------	----	------------------	----------------------	----

If the total amount of an item in the abstract is an odd, 6" or over, it would appear in the bill as a foot, but if under 6" it is entirely ignored, *e. g.* 38' 7" would be billed as 39', while 26' 2" would be taken as 26'. This also applies to other items, as any amount of half a yard or over of painting or plastering would be taken as a yard.

In slating or tiling the feet would be billed as 5, 10, 15, 20, etc., parts of 5 feet being called 5 feet, and in lead, billed at per cwt. the lbs. would be taken as 7, 14, or 21.

The first in order of the bills is known as the Preliminary Bill, which contains particulars from the conditions of contract and specification which may influence the amount of the tender, preliminary works, and provisional items. This bill does not pass through the operations of "taking off" and abstracting. It is impossible to give exact items that would appear in the above bill, as the conditions vary in different cases. A few items, however, that are found in most contracts may be given, such as:—

"The building to be completed and fit for occupation by (mention date) under a penalty of \$ — per week as liquidated damages, delays caused by frost and strikes only excepted."

"Payments may be made to the contractor at the rate of 75 per cent. of the value of the work executed, an additional 20 per cent. at completion, and the other 5 per cent. six months from that date.

A priced copy of the bill of quantities to be deposited with the architect when signing contract."

"Provide water for the use of the works, and pay all fees connected therewith."

"Insure the building for two-thirds amount of tender in an office approved by the architect."

"Give necessary notices to all authorities, supply required drawings, and pay all fees."

"Provide all scaffolding and tackle for the use of the works."

"Provide a suitable office where directed, for clerk of works, also light, fire, and attendance."

"Provide watching and lighting as required."

"Make good any injury to adjacent buildings."

"Provide temporary covering and casing to walls, stonework, etc., and protect work from frost."

"Erect hoarding as required."

"Allow for attendance of each trade upon all other trades."

"Clear away all surplus material, rubbish, and waste, scrub floors, clean glass, and leave the premises fit for occupation."

"Make good any defects appearing within six months of completion."

Provisions:

"Provide the following sums to be used as directed, or deduction in part or whole. Add for profit, carriage, and fixing."

Stoves	\$200 00
Carving	500 00

"Excavator" and other trades would be billed in their proper order after the Preliminary Bill, their total amount being carried to the summary, the usual form of which is as under:—

SUMMARY

1. Preliminary.....	
2. Excavator.....	
3. Drainage.....	
4. Bricklayer.....	
5. Mason.....	
6. Tiler (or Slater).....	
7. Carpenter.....	
8. Joiner and Ironmonger.....	
9. Smith and Founder.....	
10. Plasterer.....	
11. Plumber.....	
12. Gasfitter.....	
13. Hot-water Engineer.....	
14. Bellhanger.....	
15. Painter.....	
16. Glazier.....	
17. Paperhanger.....	
Add surveyor's charges of 2½% on the fore- going amount, to be paid out of the first instalment.....	
Add for lithography of quantities and ex- penses.....	
Carried to Tender	\$

EXAMPLE OF BILLING

BILL No. 1. PRELIMINARY AND PROVISIONS

	Preliminary works..... Provisions etc., (as previously explained).....	
	Carried to Summary	\$ <u> </u>

BILL No. 2. EXCAVATOR

The concrete to be composed of 1 part Portland Cement and 6 parts ballast, deposited steadily, and rammed in 9" layers.

yds.	ft.			
81		cube	Excavate and cart away.....	
22		"	Excavate, return, fill in, and ram	
8		"	Excavate to basement trenches, part return, fill in and ram.....	
11		"	Excavate to basement trenches and cart away.....	
4		"	Excavate to surface trenches, part return, fill in and ram.	
2		"	Excavate to surface trenches and cart away.....	
2		"	Brick core filling, rammed and levelled.....	
56		sup.	Remove top Soil 6" deep, wheel and spread where directed	
13		cube	Concrete in trenches... ..	
33		sup.	6" concrete, leveled top.....	
	No.	2	Level up over trimmers for hearths in cement concrete.	
			Carried to Summary	\$ <u> </u>

BILL No. 3. DRAINAGE

yds.	ft.					
	46	run	4" glazed stoneware drain, jointed in cement and digging average 3'3", and 6" cement concrete under and around pipes.....			\$
	6	"	4" ditto laid in tunnel, including strutting... ..			
	10	"	4" ditto in road, average depth 6 feet.....			
	7	"	4" ditto and digging, as air inlet.....			
		No.	3	Extra to 4" beuds.. ..		
		"	1	Extra to intercepting trap, with inspecting arm and stopper, including extra digging, concrete, and bedding in cement.....		
		"	1	Bull-nose slipper trap and channel, with 4" outlet and galvanized iron grating.....		
		"	1	Connect to sewer, including eye		
		"	1	Connect to 4" trap.....		
		"	1	Connect to 4" soil pipe.....		
	3	run	4" galvanized R. W. pipe....			
		"	1	Galvanized iron mica flap air inlet for 4" pipe.....		
		"	2	Connect R. W. pipe to drain and air inlet		
				Provide lighting and watching.....		
				Pay all fees to local authorities.....		
				Following in small quantities to inspection chambers		
	6	cube	Excavate and cart away.....			
	4	"	Excavate, return, fill in, and ram.....			
	2	"	Cement concrete... ..			
	65	sup.	Reduced brick work in mortar.....			
	65	"	Extra only in cement.....			
	41	run	Extra labor to oversail courses.....			
	22	"	9" trowelled cement skirting			

Carried forward \$

DRAINAGE—Continued

yds.	ft.	No.		Brought forward	\$
	0	8	run	Mitres	
				4" white glazed channel pipes, bedded and jointed in ce- ment.....	
		2		4" long channel bends.....	
		2		Cement concrete bolstering 3'×2' 6"×4½" thick laid to falls, trowelled top and made good to channels	
		2		Cast-iron air-tight covers and frames 30"×24", with grease joint, fixing and bed- ding in cement.....	
		6		Make good drain to 1 brick wall.....	
Carried to Summary					\$

BILL No. 4 BRICKLAYER

Bricks to be sound, well burnt and true in shape.
Lime to be fresh-burnt Dorking stone lime.

rods.	ft.	No.			\$
3	197		sup.	Reduced brickwork in mor- tar.....	
	13		"	Extra only in cement.....	
	22		"	Half brick wall in cement...	
	65		"	Two courses slates in cement, damp course.....	
	10		"	Asphalt damp course.....	
	19		"	Coach-head trimmer arch, half brick in cement.....	
	3		"	Rough cutting straight.....	
	22		"	Ditto circular	
	12		run	4½" rough cutting	
	88		"	Rake out and point flash- ings in cement.	
		3	No.	Extra labor and waste to relieving arches, 1B.×1B. span 3'8"	
		4	"	Extra labor, cutting and waste to relieving arches, average 3'9" span 1B.× 1 B.....	
Carried forward					\$

BRICKLAYER—Continued

	ft.	No.	4	Brought forward Terra-cotta ch. pots, 2 ft. set and flanchied in ce- ment.		\$
			2	Tile hearths P.C. and set- ting		
			26	Extra to Breeze fixing bricks		
			1	26" × 16" × 5" white glazed stoneware sink and fixing		
			3	Bed and point frames		
			6	Perforate and make good 1½ B. wall to lead pipes..		
			4	Ditto 2 B. W		
			16	Build in ends of timbers.....		
			4	Parge and core flues.		
			2	Set stoves, 3' opening		
			1	Set kitchener, 4' 6" open- ing, include for firebricks and lumps.....		
			6	9" × 6" air grids, fixing and channels in 1½ B. wall		
			1	9" × 6" plain iron outlet ventilator and fixing.....		
				<i>Facings</i>		
	233		sup.	Extra on stock brickwork for 1st quality reds fin- ished with struck joints ...		
	ft. 14		"	Ditto for gauged arches in red rubbers, set in lime putty and grouted in P. cement.		
	7		run	4½" fair cutting straight. ...		
	15		"	Cement fillet.....		
	65		"	Extra on facings to over- sailing courses.....		
		No.	6	Make good facings to ends of sills.....		
				Carried to Summary,		\$

BILL No. 5. MASON

Stone to be of the best quality, free from sand holes and vents, laid on its natural bed, and cleaned down at completion.

		<i>Lime Stone</i>		
ft.				
6		cube	Stone and setting.	\$
5		sup.	Half sawing.	
9		"	Beds and joints (1 face for 2)	
4		"	Plain work rubbed.	
6		"	Sunk work rubbed.	
3		"	Sunk work rubbed, stopped	
3		"	Moulded work.	
9		run	Throating.	
5		"	½" × ¼" groove.	
	No.	2	Form stools.	
		<i>Sand Stone</i>		
17		sup.	2" rubbed hearth.	
	No.	2	Notches.	
	"	6	12" × 10" × 6" tooled templates	
Carried to Summary,				\$

BILL No. 6. TILER

sqrs.	ft.			
5	10	sup.	Best Red tiling on sawn fir laths to 3½" gauge, fixed with galvanized nails.	
	23	run	Extra to plain Red hip tiles bedded in cement.	
	18	"	Plain Red ridge bedded and jointed in cement.	
	18	No. 1	Fair end.	
	18	run	Bedding verge in cement.	
	64	"	Bedding eaves course in cement.	
		" 1	Intersection hips and ridge to finial.	
		" 1	Extra to finial, P.C., add carriage and fixing.	
		" 2	Hip hooks.	
Carried to Summary				\$

BILL No. 7. SLATER

sqs.	ft.				
7	35		sup.	Blue Bangor Countess slating, 3" lap, centre nailed with compo nails, 2 to each slate.....	
	20		run	Slate ridge, 2 1/2" roll, 7" wings, bed and joint in cement...	
		No.	2	Fitted ends	
		"	1	Make good around pipe.....	
				Carried to Summary	\$

BILL No. 8. CARPENTER

Timber to be of the best description, sawn die square, free from sap, shakes, large, loose or dead knots, and other defects.

sqs.	ft.				
	6		cube	Spruce in plates and lintels..	
	35		"	Spruce framed in floors.....	
	37		"	Ditto in trussed partition....	
	30		"	Ditto in 3 roof trusses, hoist and fix 35' above ground-level.....	
8	103		"	Ditto in roofs.....	
	50		sup.	1" rough boarding, edges shot, to roof.....	
	80		"	1" rough boarding in gutters and 2" x 2" bearers, 15" apart.....	
	27		run	2" x 1 1/2" H.B. strutting.....	
	12		"	4 1/2" x 2" nogging pieces.....	
	12		"	Springing-piece for trimmer..	
	80		"	2" x 1" tilting fillet.....	
	80		"	3" x 3/4" ditto.....	
	80		"	1 1/2" x 9" rough board spiked to wall.....	
	40		"	2" ridge roll.....	
	160		"	Labor in splayed edge to 1" roof boarding.....	
		No.	2	Labor in scarf to 6" x 8" purlins and bolts.....	
		"	2	Ditto to 4" x 11" pole plates..	
		"	6	1" x 4" x 2" shaped cleats.....	
		"	6	9" x 4" x 4" ditto.....	
				Carried forward,	\$

CARPENTER—Continued

sqs.	ft.	No.	Description	*
			Brought forward	*
		4	Extra to form 12"×12"×6" dovetailed cesspools, holed, dished and fitted.	
		" 8	Extra to 2" rebated drips.	
		" 2	1½" roll in gutter.	
18		sup.	Use and waste of centering ..	
9		run	Turning-pieces, 4½" soffit.	
		" 66	Fixings only to 7" bolts.	
		" 19	Fixing to straps.	
			Carried to Summary	*

BILL No. 9. JOINER AND HARDWARE

sqs.	ft.	No.	Description	*
			<i>Floors in Pine</i>	
1	65	sup.	1¼" batten, edges shot, grooved, and galvanized iron tongues, splayed headings, and fixed with 2½" brads.	
	5	"	Ditto in small quantities, including bearers.	
	9	run	Extra to 3½"×½" oak border, including rebating floor, glueing and mitreing.	
			<i>Skirtings in Pine</i>	
	39	"	1"×8" moulded skirting, scribed to floor, including backings and splayed grounds plugged to wall ...	
		No. 2	External mitres.	
		" 6	Internal ditto.	
		" 2	Fitted ends.	
		" 2	Housings.	
			<i>Doors in Pine</i>	
	21	sup.	2" 6-panel, planted mouldings both sides, double tenoned for mortise lock.	
			<i>Sashes and Frames in Deal</i>	
	22	"	Cased frame and 2" sashes (description).	
			Carried forward	*

JOINER AND HARDWARE—Continued

ft.				#
			Brought forward	
	sup.	2"	ovolo-moulded casements	
	"	2"	ditto fanlight.....	
	run		Labor in hook joint.....	
13	"		Ditto in rebate and circular tongue.....	
4	"		Ditto in rebated and splayed bottom rail.....	
4	"		Ditto groove in oak.....	
4	"	3½" X 1½"	moulded and grooved weathed board....	
No.	5		Sets mouldings for glass 9' 3" long and mitres.....	
			<i>Thicknesses and Framings in Pine</i>	
9	sup.	7/8"	W.O.S. moulded grounds, splayed edge.....	
13	"	1"	rough framed grounds, 1 edge shot, 1 splayed....	
3	"	1¼"	window board, rebated and moulded and all bearers.....	
No.	2		Notched and return mould- ed ends.....	
29	sup.	1½"	jamb linings, W.O.S. framed, twice rebated, panelled with planted mouldings and dovetail backings.....	
15	run	3" X 7/8"	elbow linings, rebated 1 edge, tongued angles and backings.....	
15	"		Labor to groove.....	
4	"		Ditto in oak.....	
5	"	4½" X 3½"	framed, wrot., sunk-weathered, rebated, 3 times moulded and throated in transom.....	
18	"	4½" X 4½"	twice moulded, re- bated and hollow grooved jamb.....	
5	"	4½" X 4½"	twice moulded and rebated head.....	
			<i>In Oak</i>	
5	"	6" X 3"	framed, rebated, weathered and twice groov- ed sill.....	

Carried forward

JOINER AND HARDWARE—Continued

			Brought forward	\$
			<i>In Mahogany</i>	
	No.	1	1½" best quality W.C. seat and cover with brass side hinges	
			<i>Moulding and Sundries</i>	
5	run		2"×1½" bed moulding, rebated.....	
	No.	2	Return and moulded ends..	
17	run		4"×2" moulded architrave...	
38	"		5½"×2" ditto.....	
	"	6	Mitres.....	
	"	4	9"×6"×2½" chamfered plinth blocks	
	"	4	Frame architrave to plinth blocks	
	"	4	Housings in plinth blocks...	
	"	4	Holes in frame for saddle-bar	
	"	2	Labor to groove.....	
5	run		Allow for attendance on plumber	
			<u>Ironmongery, including</u>	
			screws and fixing.....	
	No.	2	Pairs 3½" W.I. butts.....	
	"	3	Ditto 3" brass butts.....	
	"	1	6" 2-bolt 4-lever mortise lock, P.C. and brass-reefed furniture	
	"	2	Sets brass-reefed finger plates.....	
	"	1	3" brass sash fastening... ..	
	"	2	3" brass flush sash lifts.....	
	"	2	4" brass sash pulls.....	
	"	1	Fanlight opener, P.C.	
	"	1	Brass espagnolette bolt for 6' 6" casements.....	
	"	12	Brass cups and screws....	
	"	1	Pair brackets for W. C 16½" high.....	
8	run		1½"×¼" galvanized water bar bedded in white lead..	
			Carried to Summary	\$

BILL No. 10. SMITH AND FOUNDER

cwt.	qrs.	lbs.		
				<i>Wrought Iron</i>
11	2			Plate girder, hoisting and fixing 16 ft. above ground
1	2	7		Straps.....
	2			Chimney-bars cambered and caulked.....
			No. 4	¾" bolts (fixing in "Carpenter") 11" long, square heads, nuts and washers.....
			" 6	½" ditto, 13" long.....
			" 56	½" ditto, 6" long.....
	ft.		" 3	Sets gibs and cotters.....
	4		run	½" round galvanized iron saddle-bar.....
				<i>Cast Iron</i>
11	0	0		Hollow column fixed at ground-level.....
	ft.		No. 1	Pattern for above.....
	10		run	2" R. W. pipe and fixing...
			" 1	Extra to 2" shoe.....
			" 1	2" R. W. head.....
Carried to Summary				

BILL No. 11. PLASTERER

Laths to be lath and half butted, broken joints, and nailed with cut nails.

yds.	ft.			
				<i>Internally</i>
23			sup.	Lath, plaster, float and set ceilings.....
29			"	Ditto on partitions.....
22			"	Render, float and set walls..
	68		"	Plaster moulded cornice.....
			No. 6	Internal mitres.....
			" 2	External ditto.....
	18		run	Keene's cement angle.....
Carried to Summary				

BILL No. 12. PLUMBER

Qty	Qrs.	Lbs.		
40	1	14		<i>Externally</i>
	ft.			Milled lead and labor in flats, gutters, and flashings
88			run	Lead wedging.....
17			No.	4 Copper nailing, open.....
				Labor, dress angles around curb.....
			"	28 Labor, bossed ends to rolls
			"	13 Labor, four-way intersections
			"	4 Extra lead, flux, and solder in cess-pool.....
			"	4 1" socket pipe, 2 ft. long, double bent out of 7-lead, and joint.....
			"	4 Domical wire covers to cess-pools.....
				<i>Internally</i>
25			run	¾" strong lead pipe and digging trench.....
75			"	¾" lead pipe, bends, and fixing.....
11			"	1" ditto.....
13			"	1¼" ditto.....
5			"	1½" ditto.....
			No.	1 ¾" soldered joint.....
			"	1 ¾" short length pipe.....
			"	1 ¾" ditto and soldered joint.....
			"	1 ¾" ditto and two joints.....
			"	1 Extra to trumpet-mouth connection to sink grating.
			"	2 ¾" boiler screws and joint.....
			"	1 ¾" union and joint.....
			"	1 1" inch brass bath overflow grating, union and joint.....
			"	1 1¼" brass combined bat-waste and trap, cleansing screw, and plug and joint.....
			"	2 1½" brass clips.....
			"	1 3" brass sink grating.....
			"	1 ¾" H.P. screw-down tapcock and joints.....
			"	1 ¾" H.P. screw-down bib valve and boss.....
			"	1 ¾" copper ball valve, boss, and soldered joint.....
			"	1 1¼" lead S trap, screw cap, and joints.....

Carried forward

PLUMBER Continued

		Brought forward	\$
	1	Galvanized riveted cistern, 80 galls., and	
	4	Drill	
	1	5 ft. porcelain bath, enameled top, enameled, and combined hot and cold brass valve and joints	
	1	Drill hole	
		1 1/2 in. brass pipe pull	
	1	Cast iron jacket	
	1	Cast iron ash down	
		Copper pipe	
ft		25	
		1 1/2 in. 7-lb.	
		Including joints, tacks, and wall	
		Cast iron 90 degree bend and	
		Between W. C. trap and soil pipe, including collar	
		Connect soil pipe to drain, including brass thimble	
		Galvanized copper wire cover	
		Connect with Water Co.'s pipe, including ferrule, labor fees, and making good road	
		Work on back and box	
		Carried to Summary	\$

BILL No. 13. HOT-WATER ENGINEER

ft.					
10		run.	3/4"	steam pipe.....	3
6		"	1"	ditto	
42		"	1 1/4"	ditto	
	No.	2	3/4"	bends	
	"	6	1 1/4"	ditto	
	"	1	3/4"	elbow	
	"	2	1 1/4" x 3/4"	tees	
	"	1	3/4"	short length pipe	
	"	1	Galvanized W. I. tank, 1/8"	plate bare with manhole, 30 galls., bearers and fixing	
	"	4	Drill holes and connections		
	"	2	1 1/4"	brass unions	
	"	1	1"	ditto	
	"	1	3/4"	ditto	
	"	1	3/4"	screw-down bib valve, engraved "HOT," and joint to iron pipe.....	
	"	1	12" x 10" W. welded arched high pressure boiler.....		
	"	2	Drill holes and connect. Include short lengths of pipe, back-nuts and joints		
	"	1	3/4"	dead-weight safety valve and joint to iron	
			Allow for attendance in cutting away and making good after hot-water en- gineer, and test system at completion... ..		
			Carried to Summary		\$

BILL No. 14. PAINTER

All materials to be of the best quality.

nds.	ft.			
			<i>Knot, prime, stop, and 3 oils</i>	
1		sup.	General woodwork.....	\$
	47	run.	Skirting	
	No.	$\frac{1}{3}$	Dozen sash sheets, very large	
	"	$\frac{2}{3}$	Dozen sash squares, very large	
	"	2	Fanlights	
	"	2	Sash frames, ordinary	
	"	2	Casement frames, very large	
	"	4	Plinth blocks.....	
			Carried to Summary	\$

BILL No. 15. GLAZIER

All glass to be best quality and free from bubbles.

ft.				
13		sup.	21-oz. sheet glass in squares, 6' to 8' super., and glazing	
19		"	$\frac{1}{4}$ " polished plate in squares, 4' to 6' super., bedded in chamois leather.....	
6		"	Stout lead quarry lights, with rolled cathedral plate (selected tints), copper ties and fixing.....	
			Carried to Summary	\$

BILL No. 16. PAPERHANGER

All paper to be hung with butt joints.

No.	4	Pieces of paper, price 50 cts. per piece, and hanging to ceiling	
"	11	Pieces of paper, price 75 cts. per piece, and hanging to walls	
		Carried to Summary	\$

ITEMS

There is danger of the quantity surveyer overlooking some important item, and in order to prevent this, the following items have been prepared so that *measurement*, of as many as possible, shall be measured:

Inspection of site	Removing debris
Examination of soil	Sodding
Note if gravel, soil, or sand	Carriageways
Figure accordingly	Footpaths
Get number of cubic yards	Driveways to rear
The distance to be removed	Tamping earth
Where to be deposited	Concreting foundation
Pumping water	Openings for drain pipes
How drained	Laying drain pipes
Sewerage	Area of all tiles
What depth of drains	Weeping tiles
Depth of cellar	Elbows and bends
Depth of foundation walls	Traps of all kinds
Width of footings	Intake water pipes
Rock blasting	Waste pipes
Shoring banks	Footings
Piling for foundations	Cellar walls
Sheet piling	Furnace room
Excavations for piers	Walls laid in cement
Cesspool	Walls laid in lime mortar
Cistern	Walls built up of concrete
Trenches	Stone walls, field stone
Cuttings for water pipes	Stone walls, quarried stone
Grading	Stone walls, dimension stone
Leveling cellar floor	Brick walls for cellar
W. C. for workmen	Amount of stone
Removing fences	Amount of bricks
Grubbing out tree stumps	Amount of concrete
Removing surplus soil	Cellar steps

Cellar windows	Cupboards and drawers
Cellar doors	Tool room
Cellar partitions	Wash bowl and stand
Cellar coping stones	Kind of hardware
Cellar sills and lintels	Ground floor
Bond stones	Number of rooms
Cellar water closet	Number of doors
Water taps, etc.	Number of windows
Concrete and cement floor	Style of doors
Plank floor	Style of windows
Earth floor tamped	Sizes of doors and windows
Wine cellar	Thickness of doors and win- dows
Vegetable cellar	Kind of glass
Coal storage bins	How windows are hung
Coal chute	Hardwood or pine finish
Ashes receiver	Outside walls, stone, brick or wood
Cellar stairs	Thickness of walls
Preserve closet	If stone, rock face
Shelving	Tooled, rubbed
Plastering walls and ceilings	Cross tooth chiseled
Damp courses in walls	Crandalled
Double sashes in windows	Brick wall
Doors, what kind	Thickness of brick walls
Fireplace and chimney	Common bricks
Laundry tubs	Pressed bricks
Hot and cold water supply	First, second and third quality
Furnace and attachments	Mixed, brick and stone
Furnace, hot water	Walls ornamented
Furnace, steam water	Walls left plain
Furnace, hot air	Window finish
Gas jets, how many	Urinals
Electric lights, how many	Slate slabs
Laundry table	Exterior window finish
Clothes drying device	Interior window finish
Mangle	Exterior door finish
Chimney piece	Interior door finish
Stove rings	Betting courses
Registers	Sailing courses
bar finish	
wardrobe hooks and pins	

Laid in cement or mortar	Jets and gasoliers
Front steps, stone	Electric lighting
Front steps, cement or wood	Electroliers and brackets
Hall entrance	Piping for gas
Double floor, pine	Wiring for electric lights
Hardwood floor	Fitting clothes closets
Parquet floor in some rooms	Fitting up den
Tile floors	Fitting up closets
Dimensions of joists	Fitting up cellar stairs
Thickness of floors	Fitting up dining room
Height of ceilings	Fitting up other rooms
Stairs, straight	Kitchen finish
Stairs, winding	Tubs, sinks, dresser
Stairs, platform	Cupboards, china closet
Pine or hardwood	Butler's pantry
Kind of hardwood	General pantry
Styles of newels and balusters	Range
Plain finish in rooms	Steam cooker
Ornamental finish in rooms	Chimneys
Fret and grill work	Ventilation
Arches, plain or otherwise	Painting
Styles of plastering	Varnishing
Stucco cornices	Wainscot
Styles of cornices	Panelings
Sliding doors	Washstands
Fireplaces	Marble facings for walls
How many	Double windows
Mantelpieces	Sashes, weights and cords
Mantelpieces, plain or ornamental	Box frames
How finished	Plain frames
Other wood finish	Window stools
Pillars, columns or brackets	Inside shutters
Base and plinth	Inside blinds
Style of trimmings	Splay boxes
Style of hardware	Tiled hearths
Cost of hardware	Sash locks
Crates and tiles	Tiled facings
Mirrors	Back stairs
Gas lighting	Servant's room
	Bay window

Oriels
 Veranda
 Front porch
 Rear porch
 Stoop
 Back areas
 Front areas
 Iron railings
 Stone railings
 Balconies
 Window hoods
 Door hoods
 Door stops
 Door springs
 Plate glass
 Stained glass
 Niches
 Closet fittings
 Provide for heating
 Conservatory
 Corrugated glass
 Skylights
 Handrail, oak or mahogany
 Bracketed stairs
 Anchors and tie irons
 Vaults
 Angle irons
 Bond timbers
 Carving, if any
 Scaffolding
 Temporary enclosure
 Iron beams
 Iron columns
 Gas pipe pillars
 Water on main floor
 Taps, nickel plated
 Taps, plain
 Glazier's work
 Meters, syphons
 Elbows, pendants
 Painting
 Paper hanging
 Iron pipes
 Lead pipes
 Brass pipes
 Washers, wastes
 Plugs, grating
 Pumps, suction pipes
 Wall hooks, supply pipes
 Cast iron work
 Wrought iron work
 Stucco work generally
 Stucco friezes, enrichments
 Stucco pateras, panels
 Stucco moldings
 Stucco beads, straight
 Stucco beads, over arches
 Stucco arrises, quirks
 Stucco reveals angles
 Stucco centerpieces
 General plastering
 Two coats
 Three coats
 Lathing
 Quality of laths
 Sand, lime and hair
 Plaster of Paris
 Clean water
 Sound story joists
 Studding for partitions
 Beams
 Trimmers for hearths
 Trimmers for stairs
 Trimmers for chimneys
 Strapping walls
 Dimensions of strapping
 Wooden bricks
 Plugging walls
 Nailing strips
 Temporary sashes

Lanterns	Brick veneered building
Louvres	Wood cornice outside
Thresholds	Metal cornice outside
If metal ceilings	Shingle cornice outside
If metal cornices	Brick cornice outside
Metal centerpieces	Stone cornice outside
Bridging joists	Attic floor joists
Bridging studding	Rafters
Dimension of studs	Collar beams
Double partitions for sliding doors	Trusses for roofs
Lining pocket of sliding doors	Framing for dormers
Hanging sliding doors	Framing for eye-winkers
Framing wooden house	Dormer windows
Boarding inside	Chimney stacks
Boarding outside	Framing roof
Boarding both sides	Boarding roof
Papering one or both sides	Mortar under shingles
Horizontal boarding	Mortar under slate
Diagonal boarding	Asbestos paper under covering
Tar paper or plain paper	Common paper under covering
Outriggers	Shingle roof
Towers	Slate roof
Two-story bay windows	Tile roof
Two-story oriels	Composition roof
Two-story balcony	Tin roof
Two-story porches	Galvanized iron roof
Two-story verandas	Roofs painted
Three or more stories of same	Flashing of all kinds
Iron railings for balconies	Tin flashings
Wood railings for same	Zinc flashings
Ornamental iron column	Galvanized iron flashings
Ornamental brackets, iron	Eave troughs
Iron supports for platform	Conductor pipes
Iron trusses for balconies	Size of conductor pipes
Iron plates for piers	Mansard roof
Other iron work	Saddle roof
Siding frame buildings	Hip roof
Half-timbered building	Flat roof
Rough cast building	Tower roof
	Square tower roof

Conical roof	Style of water closet
Steeple roof	Marble washstand
Polygon roof	Tiled walls
Bay window roof	Tiled floor
Porch roof	Marble lined walls
Roof over balcony	Ventilation
Veranda roof	Air ducts
Framings for veranda	Register
Chamber floors	Bath trimmings
Attic floors	Shower bath
Bedroom fittings	Hot and cold water
Number of doors in bedrooms	Stairway to attic
Washbasins	Attic storerooms
Closets, drawers and fitments	Attic, clothes drying room
Servants' bedrooms	Children's playroom in attic
Hall, sewing room	Inside trim of dormer windows
Continuous stairway	General finish of attic
Bathroom and fitments	Water closet and lavatory in attic
Water closet, in what style	Painting in attic
Bathroom washstand	Attic doors
Linen closet	Heating attic
Nursery	Attic storeroom
Fireplaces	Children's toy room
Mantels	Hall in attic
Tiling for fireplaces	Railing around attic stairway
Base, style of finish	Closets in attic
Built in seats	Water in attic
Finish in main bedroom	Plastering in attic
Finish in nursery	Attic walls all boarded
Finish in servant's room	Matched ceiling in attic
Finish in bathroom	Attic hardware
Finish in hall	Chimney tops
Finish in closets	Style of chimney tops
Openings and arches	Chimney pots
Style of painting	Finishing top of chimney
Pine finish	Stone tops
Hardwood finish	Cement tops
Character of finish	Metal tops
Cost of hardware	Roof decks
Style and cost of bath tub	

Railing for decks	Chestnut posts
Rolls for ridges	Spandid panels
Cresting for ridges	Lattice work
Wood cresting	Entrance approach
Metal crestings	Porte-cochère
Terra cotta crestings	Stepladders
Terra cotta panels	Refrigerator
Terra cotta work generally	Cold storage shelving
Hatchway in deck	Wine bottle racks
Scuttle in deck	Folding partitions
Lead work	Boxed shutters
Copper work	Boxed blinds
Tin work	Sliding blinds
Roof painting	Rolling blinds
Painted or dipped shingles	Venetian blinds
Stairs to roof or deck	Dumb waiter
Flagpole	Transom doors
Halyards	Transom windows
Wire guards	Mullion windows
Snow guards	Circular top windows
Storm sashes	Elliptical windows
Storm doors	Double-hung windows
Screen doors	Single-hung windows
Wire screens for windows	Windows, plain
Wood gables	Windows, ornamental
Brick or stone gables	Pavements
Half-timbered gables	Slop hoppers
Plastered gables	Vestibule
Shingled gables	Vestibule partition
Deafening floors	Vestibule floor
Deafening walls	Hardwood or tile
Pugging floors	Wainscot in vestibule
Sub-floors	Wainscot in stairway
Diagonal floors	Paneled stair strings
Rough floors	Hardwood stairs
Cellar sleepers	Wood-shed
Cedar posts	Coal-shed

While the foregoing does not pretend to give all the items that may be required, it offers to the measurer some

hints as to what is required, in a general way, for domestic buildings. For factories, stables, barns, warehouses, public buildings, churches, schools, railway stations, and similar work, a more elaborate list would be required, but the workman should be able to find all the items in the specifications prepared for the work under consideration, and if he is thorough he will add to the list as given above such items with their cost, as he goes over them when taking off the quantities.

The reader of this book, should also obtain a copy of Hodgson's Estimator and Contractor's Guide; which is a companion book to this. This one gives methods of computing quantities, the Contractor's Guide shows how to price them. So it will be seen that the two books should go together.

INDEX.

	PAGE
RULES FOR MEASUREMENT OF	
Mason Work.....	7
Brick Work.....	18
Wright Work.....	23
Glazier Work.....	38
Slater Work.....	42
Plumber Work.....	45
Plaster Work.....	49
Painter Work.....	53
METHODS OF MEASURING.....	58
FORM OF DIMENSION BOOK.....	59
METHOD OF MEASURING:	
Mason Work.....	60
Brick Work.....	77
Carpenter and Joiner Work.....	82
Glazier Work.....	93
Slater Work.....	95
Plaster Work.....	97
Plumber Work.....	103
Painter Work.....	107
FORM OF MEASUREMENT FOR:	
Mason and Brick Work.....	110
Plaster Work.....	137
Plumber Work.....	139
Tile Linings.....	142
Painter Work.....	143
FORM OF ESTIMATE FOR:	
Excavator, Mason, Brick, Iron and Steel Work.....	64
Carpenter and Joiner Work.....	122
Slater Work.....	100
Lather and Plaster Work.....	101
Plumber Work.....	103
Tile Linings.....	106
Painter Work.....	107

INDEX

	PAGE
NOTES ON:	
Excavator Work.....	147
Mason and Brick Work.....	150
Carpenters and Joiners Work.....	155
Slater Work.....	161
Plaster Work.....	162
Plumber Work.....	163
Painter Work.....	167
FORM OF:	
Mason Work in Note Book.....	168
Brick Work in Note Book.....	172
Carpenter and Joiner Work in Note Book.....	173
Slater Work in Note Book.....	183
Plaster Work in Note Book.....	184
Plumber Work in Note Book.....	189
Painters Work in Note Book.....	191
ABBREVIATIONS THAT MAY BE USED IN NOTE	
BOOK.....	196
PRACTICAL MEASUREMENTS OF GEOMETRICAL	
AREAS.....	199
ABSTRACTING	213
EXAMPLES OF ABSTRACTING.....	218
EXCAVATOR	218
DRAINAGE	219
BRICKLAYER ..	220
MASON	222
TILER	223
SLATER	224
CARPENTER	224
JOINER AND HARDWARE.....	226
SMITH AND FOUNDER	229
PLASTERER	231
PLUMBER	231
HOT WATER ENGINEER.....	234
PAINTER	235
GLAZIER	235
PAPER HANGER.....	235
BILLING	236
SUMMARY	239
EXAMPLES OF BILLING.....	240
ITEMS	254

NOTICE

To the many workmen who are purchasing the publications under the authorship of Fred T. Hodgson, and who we feel sure have been benefited by his excellent treatises on many Carpentry and Building subjects, we desire to inform them that the following list of books have been published since 1903, thereby making them strictly up-to-date in every detail. All of the newer books bearing the imprint of Frederick J. Drake & Co. are modern in every respect and of a purely self-educational character, expressly issued for Home Study.

PRACTICAL USES OF THE STEEL SQUARE, two volumes, over 500 pages, including 100 perspective views and floor plans of medium-priced houses. Cloth, two volumes, price \$2.00. Half leather price \$3.00.

MODERN CARPENTRY AND JOINERY, 300 pages, including 50 house plans, perspective views and floor plans of medium and low priced houses. Cloth, price \$1.00. Half leather, price \$1.50.

BUILDERS' ARCHITECTURAL DRAWING SELF-TAUGHT, over 350 pages, including 50 house plans. Cloth, price \$2.00. Half leather, price \$3.00.

MODERN ESTIMATOR AND CONTRACTORS' GUIDE, for pricing builders' work, 350 pages, including 50 house plans. Cloth, price \$1.50. Half leather, price \$2.00.

MODERN LOW-COST AMERICAN HOMES, over 200 pages. Cloth, price \$1.00. Half leather, price \$1.50.

PRACTICAL UP-TO-DATE HARDWOOD FINISHER, over 300 pages. Cloth, price \$1.00. Half leather, price \$1.50.

COMMON SENSE STAIR BUILDING AND HANDRAILING, over 250 pages, including perspective views and floor plans of 50 medium-priced houses. Cloth, price \$1.00. Half leather, price \$1.50.

STONEMASONS' AND BRICKLAYERS' GUIDE, over 300 pages. Cloth, price \$1.50. Half leather, price \$2.00.

PRACTICAL WOOD CARVING, over 200 pages. Cloth, price \$1.50. Half leather, price \$2.00.

Sold by booksellers generally, or sent, all charges paid, upon receipt of price, to any address in the world

FREDERICK J. DRAKE & CO.
PUBLISHERS OF SELF-EDUCATIONAL BOOKS
350-352 WABASH AVE., CHICAGO, ILL.

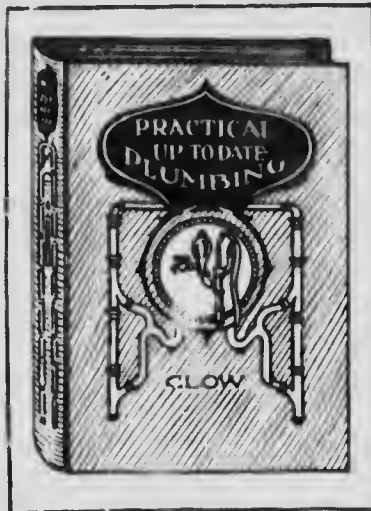

Practical Up-to-Date PLUMBING

By
George B. Clow

Over 150
Illustrations

A PRACTICAL up-to-date work on Sanitary Plumbing, comprising useful information on the wiping and soldering of lead pipe joints and the installation of hot and cold water and drainage systems into modern residences. Including the gravity tank supply and cylinder and tank system of water heating and the pressure cylinder system of water heating. Connections for bath tubs. Connections for water closet. Connections for laundry tubs. Connections for wash-bowl or lavatory. A modern bath room. Bath tubs. Lavatories. Closets. Urinals. Lavatories. Shower baths. Toilet room in office buildings. Sinks. Faucets. Bibb-cocks. Soil-pipe fittings. Drainage fittings. Plumber's tool kit, etc., etc. 256 pages, 180 illustrations.

12 Mo. Cloth \$1.50

Sold by Booksellers generally or sent postpaid to
any address upon receipt of price by the Publishers

FREDERICK J. DRAKE & CO.
350-352 Wabash Ave., Chicago, U. S. A.

The Signist's Book of Collected
and
Modern Alphabets Engraved
by F.
Delamotte

Large oblong
octavo, 208
pages, 100
designs
Price, \$1.50

N. B.—We
guarantee this
book to be
the largest and
best work of
this kind
published



PLAIN and Ornamental, ancient and mediæval, from the Eight to the Twentieth Century, with numerals. Including German, Old English, Saxon, Italic, Perspective, Greek, Hebrew, Court Hand, Engrossing, Tuscan, Riband, Gothic, Rustic, and Arabesque, with several Original Designs and an Analysis of the Roman and Old English Alphabets, Large, Small, and Numerals, Church Text, Large and Small; German Arabesque; Initials for Illumination, Monograms, Crosses, etc., for the use of Architectural and Engineering Draughtsmen, Surveyors, Masons, Decorative Painters, Lithographers, Engravers, Carvers, etc.

Sold by Booksellers generally or send postpaid to
any address upon receipt of price by the Publishers

Frederick J. Drake & Company
350-352 WABASH AVENUE :: CHICAGO, U. S. A.

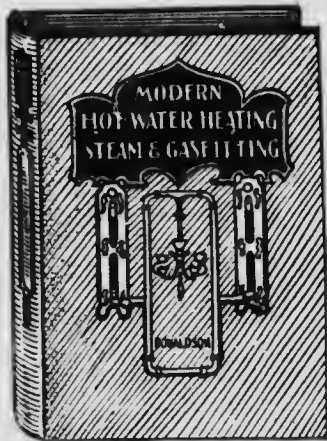

Hot Water Heating, Steam and Gas Fitting

By *W.M. DONALDSON*

A MODERN treatise on Hot Water, Steam and Furnace Heating, and Steam and Gas Fitting, which is intended for the use and information of the owners of buildings and the mechanics who install the heating plants in them. It gives full and concise information with regard to Steam Boilers and Water Heaters and Furnaces, Pipe Systems for Steam and Hot Water Plants, Radiation, Radiator Valves and connections, Systems of Radiation, Heating Surfaces, Pipe and Pipe Fittings, Damper Regulators, Fitters' Tools, Heating Surface of Pipes, Installing a Heating Plant and Specifications. Plans and Elevations of Steam and Hot Water Heating Plants are shown and all other subjects in the book are fully illustrated.

256 pages, 121 illustrations, 12mo, cloth, price, \$1.50

Sold by Booksellers generally or sent postpaid to any address upon receipt of price by the Publishers

FREDERICK J. DRAKE & CO.
350-352 WABASH AVENUE, CHICAGO, U.S.A.

Hodgson's Modern Estimator and Contractors' Guide

For Pricing Builders' Work

Cloth, \$1.50

Half Leather, \$2.00

SYNOPSIS OF CONTENTS.

Introduction to estimating—Remarks on tendering for work—Terms of payment—Discounts—System in estimating—Reminders of items in work and materials—Different methods of estimating—Some remarks on estimating generally—Estimating by stories—Mensuration of superficies—Definitions—Four-sided figures—Triangles—Trapeziums and Trapezoids—Regular polygons—Irregular bodies—Circles and segments—Ellipses and similar figures—Hyperboles—Table of segments of circles—Table of zones of circles—Areas of zones of circles—Lengths of circular arcs—Length of elliptical arcs—Cubes and solids—Pyramidal measurements—Wedge and prismoids—The cylinder, cone and sphere—Spheroids—Conoids and hyperboloids—Average rates of wages per hour for the year 1904—Loads for wagons, carts, wheelbarrows and baskets—Loads of earth, bricks, stone, tiles, slates, lumber, timber, mortar, lime, concrete, sand, clay, ballast, etc.—Cubic contents of earth before and after digging—Weight of various materials—Cost of items of work of various kinds in Philadelphia, Boston, New York, Chicago, San Francisco and other large cities at this date (1904)—Excavating for trenches, drainage, footings and similar work, with hints as to cost, etc.—Pricing items of excavation in various soils—Some things worth knowing in excavating—Natural slopes—Trimming banks—Equivalents of slopes—Irregular sites—Runs for wheelbarrows—Weights of materials—Steam excavators and shovels—Cost of excavating—Rough approximate prices—Laying drain tiles, pipes, weeping tiles and similar work—Rain-fall and clearance of same—Table of gradients—Clay tiles and cast iron pipes—Weeping tiles—Footings for foundations—Cut stone—Cement stone—Percentage of cost—Determining the cost of labor—Table of rate of wages paid different trades (1904)—Estimating by the square—Analysis of work generally—Estimating by units of accommodation—Method explained—Estimating by cubing—Table showing cost per foot, name of building, and date of erection—Prices of work of various kinds—Cost of parks and public grounds per acre—Estimating by detail quantities—Remarks and suggestions on this method of estimating—Prices of work per item, or by the hour at present date (1904)—Slating—Slater's memoranda—Slate balls for any superficial area with table and rules—General matters—Itemized work with prices attached—Plasterer's data—Bricklayer's data—Stone mason's data—Carpenter's data—Painter's data—Painter's extras—The plasterer and painter—Stucco work—External plastering in Portland cement—Outside plastering generally—Tiles and tiling with cost of labor and material—Fixing tiles—Proof tiles and laying same—Cost of slate—Bangor black slate—Brownville Maine slate—Green, purple and red slate—Peach bottom slate—Sea-green slate—Weight of slate—Measurement of slating—Cost of slating—The excavator and bricklayer—Rules, tables, notes, data and pointers useful to the estimator—Table of weight of cast iron drain and soil pipes—Table showing number of bricks required for any size of wall—Measurement of brickwork—Safe bearing loads—Masonry generally—Proportion of bricks and mortar—Number of bricks required for well and other circular work—Thickness of brick walls for dwelling houses—Walls for cold storage and warehouses—Roofs generally—Shingling—Table for estimating shingles—Slating—Weight of roof covering—Snow and wind loads—Wind pressure on roofs—Comparative cost of roofs—Composition roofs—Specific gravity and weights—The metric system—Measures of length—Measures of area—Measures of volume—Current measures—Weights of lumber of the Pacific coast—Surveyor's measure—Square measure—Surveyor's square measure—The wear and tear of building materials—Stone and brick work—How to figure plastering—Short hints on stone and brick work—Short methods of estimating—Some pointers on estimating—Miscellaneous tables, rules and general information useful to the estimator—Closing remarks with hints and suggestions as to how to estimate systematically, and proper methods of keeping data and memoranda, etc., etc., etc.

FREDERICK J. DRAKE & CO., Publishers,

250-252 WABASH AVE., CHICAGO, ILL.

Modern Carpentry Vol. 2

ADVANCED SERIES

By Fred T. Hodgson

This is a continuation of Mr. Hodgson's first volume on **Modern Carpentry** and is intended to carry the student to a higher plane than is reached by the first volume.

The first volume of this series may be considered as the alphabet of the science of carpentry and joinery, while the present volume leads the student into the intricacies of the art and shows how certain difficult problems may be solved with a minimum of labor. Ever progressive workman and especially those who have purchased the first volume of this series cannot afford to be without this volume, as it contains so many things necessary the advanced workman should know, and that is likely to crop up at any time during his daily

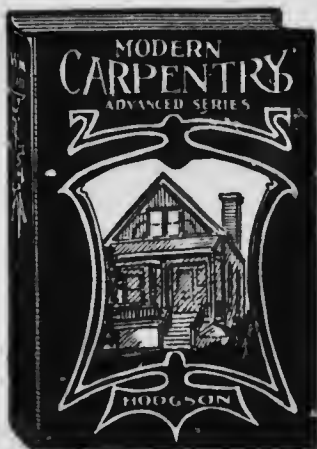

labors. The work is well illustrated with over 100 diagrams, sketches and scale drawings which are fully described and explained in the text. Many puzzling working problems are shown, described and solved. This is truly a valuable aid and assistant for the progressive workman.

300 pages, fully illustrated. 12mo, cloth, price, \$1.50

Sold by Booksellers generally or sent postpaid to any address upon receipt of price by the Publishers

FREDERICK J. DRAKE & CO.

350 352 WABASH AVE., CHICAGO, U. S. A.

PRACTICAL BUNGALOWS
AND COTTAGES FOR
TOWN AND COUNTRY



THIS BOOK CONTAINS PERSPECTIVE
DRAWINGS AND FLOOR PLANS

OF ONE HUNDRED LOW AND MEDIUM PRICED HOUSES
RANGING FROM FOUR HUNDRED TO FOUR THOUSAND
DOLLARS EACH. ALSO TWENTY-FIVE SELECTED
DESIGNS OF BUNGALOWS FOR SUMMER AND COUNTRY
HOMES, FURNISHING THE PROSPECTIVE BUILDER
WITH MANY NEW AND UP-TO-DATE IDEAS AND SUG-
GESTIONS IN MODERN ARCHITECTURE
THE HOUSES ADVERTISED IN THIS BOOK ARE EN-
TIRELY DIFFERENT IN STYLE FROM THOSE SHOWN
IN HODGSON'S LOW COST HOMES

12 MO. CLOTH, 200 PAGES, 300 ILLUSTRATIONS
PRICE, POSTPAID \$1.00

FREDERICK J. DRAKE & CO.

350-352 WABASH AVENUE
CHICAGO

Concretes, Cements, Mortars, Plasters and Stuccos

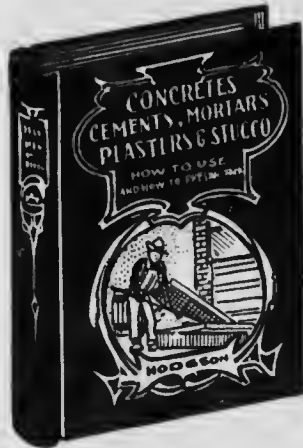

How to Make and
How to Use Them

By

Fred T. Hodgson
Architect

THIS is another of Mr. Hodgson's practical works that appeals directly to the workman whose business it is to make and apply the materials named in the title. As far as it has been possible to avoid chemical descriptions of limes, cements and other materials, and theories of no value to the workman, such has been done, and nothing has been admitted into the pages of the work that does not possess a truly practical character.

Concretes and cements have received special attention, and the latest methods of making and using cement building blocks, laying cement sidewalks, putting in concrete foundations, making cement casts and ornaments, are discussed at length. Plastering and stucco work receive a fair share of consideration and the best methods of making and using are described in the usual simple manner so characteristic of Mr. Hodgson's style. The book contains a large number of illustrations of tools, appliances and methods employed in making and applying concretes, cements, mortars, plasters and stucco, which will greatly assist in making it easy for the student to follow and understand the text.
300 pages fully illustrated.

12 Mo. Cloth, Price, \$1.50

Sold by Booksellers generally or sent postpaid to
any address upon receipt of price by the Publishers

Frederick J. Drake & Co.
350-352 Wabash Ave., CHICAGO, U. S. A.

