

NOVEMBER 14, 1915

PUBLISHED EVERY WEEK. \$1.50 PER YEAR.

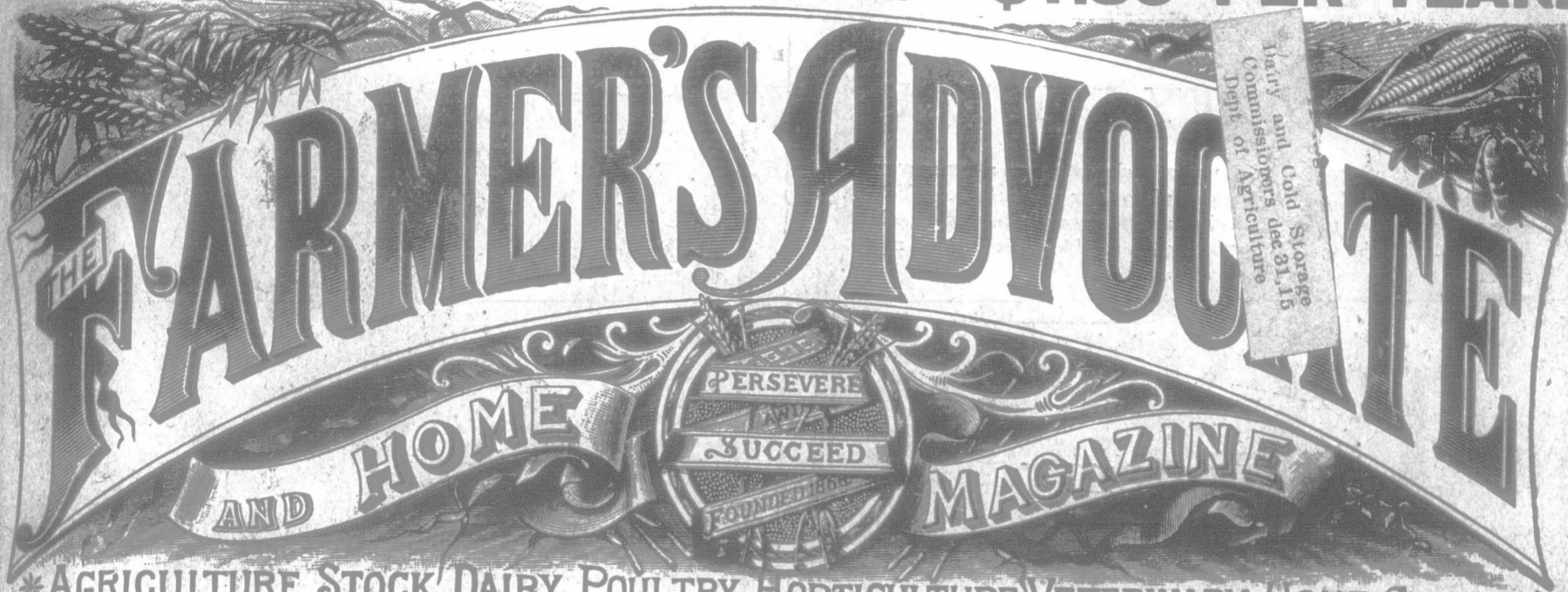

AGRICULTURE, STOCK, DAIRY, POULTRY, HORTICULTURE, VETERINARY, HOME CIRCLE

ENTERED IN ACCORDANCE WITH THE COPYRIGHT ACT OF 1875.

VOL. L.

LONDON, ONTARIO, NOVEMBER 25, 1915.

No. 1209

INTERNATIONAL POULTRY FOOD TONIC

An Extraordinary Egg Producer. It purifies the blood, stimulates the appetite and keeps poultry healthy and helps hens lay more eggs. We positively guarantee a great increase in the number of eggs received when INTERNATIONAL POULTRY FOOD TONIC is used. Sold in packages, 25c, 50c and \$1.00.

INTERNATIONAL WORM POWDER

Quickly Expels Worms. Is a superior concentrated vermifuge for horses, colts and other animals. It expels the worms and removes the primary cause. It is very effective and absolutely safe for young animals. Price per package, 50c.

INTERNATIONAL COLIC REMEDY

Cures Colic for 50c. INTERNATIONAL COLIC REMEDY is guaranteed to cure in ten minutes. It is put up in handy drenching bottles. Price, 50c and \$1.00.

INTERNATIONAL DISTEMPER REMEDY

Coughs and Distemper can be quickly cured by its use. INTERNATIONAL DISTEMPER REMEDY is prepared from absolutely pure drugs in a highly concentrated form. If it ever fails your money promptly refunded. Price per package, 50c.

INTERNATIONAL HEAVE REMEDY

Heaves, Asthma, Broken Wind, Coughs, etc. It is prepared from several valuable medicinal ingredients and gives remarkable results. Price, 50c per package.

INTERNATIONAL SILVER PINE HEALING OIL

Quickly heals Cuts, Bruises, etc. It is composed of pure vegetable oils, possessing wonderful healing properties. Especially recommended for sores, kicks, chafes, inflammation, swellings, bruises, sprains from rusty nails, all flesh wounds. Wonderful cure for barb wire cuts. Price per bottle, 25c, 50c and \$1.00.

INTERNATIONAL LOUSE KILLER

Is a very fine, pure white powder that will kill lice in the feathers when applied and is safe to the death of lice. Will not discolor the feathers or plumage of the whitest birds. Will destroy lice, ticks, fleas, etc., on horses, cattle, sheep, hogs, poultry, etc. Put up in an extra large round box with a blanking top ready for instant use. Price, per box, 25c.

INTERNATIONAL GROFAST CALF MEAL

Is a scientific, high-grade substitute for milk in the quick growing of calves. "GROFAST CALF MEAL" is highly mixed; calves like it, and they grow and develop as rapidly as on new milk. Sell your milk and raise your calves at a very low feeding cost, which makes you much more money.

GROFAST CALF MEAL will raise calves at the cost of raising one on milk.

We have a special booklet, entitled "How You Can Raise and Grow Calves at Low Cost Without Milk," which we will gladly mail anyone interested.

GROFAST CALF MEAL is put up in 50 and 100-pound bags.

These Preparations are sold by Dealers everywhere on a Spot Cash Guarantee. Your money refunded in case of failure. Beware of Substitutes and Imitations.

...y, Limited
...ADA

The Tale of Two Fence-Buyers

This man bought Frost Fence



He saw the goods before buying, paid for fence service and got it.

His fence investment proved to be one of the best he ever made.

DURING the coming year the farmer must use more caution than ever in purchasing his wire fence.

Manufacturers, on account of the war, are compelled to pay a great deal more for all raw materials, and consequently must increase the selling price of their goods, unless, of course, they have a small quantity of old stock, which cost much less. Some again may adopt the decreased quality idea, which soon means dissatisfaction. The Frost method has not and will not change. Frost Fence is higher in price; but just as good as ever in quality.

We refuse to decrease the quality

FROST FENCE, to those who have used it needs no introduction. They can rest assured that we will keep our products just as good or better. Upwards of twenty years' service is woven right into its make-up. You'll do well to test our claim of "Longer Service at Lower Cost."

FROST FENCE is made complete in a Canadian factory. The wire is drawn, galvanized, and woven into fence right in this factory. The users of Frost Fence are not dependent on galvanized wire made in the United States. Instead, they get wire made especially for fence use.

The distribution of Frost Fence is made through dealers who buy in car lots. Thus you get the fence at the lowest freight rate. Moreover, you can examine it before you hand over your money.

You pay for and expect "service." Why not buy FROST "FENCE" and get it?

FROST FENCE FIRST

This man bought the other kind



He bought "sight unseen," and paid his money out for fence of unknown value.

His experience cost him money, for he soon needed a new fence.

FROST WIRE FENCE CO., Limited, HAMILTON, CANADA

MORE MONEY FOR YOU

If you have a good sawing rig you will not only saw all your own wood, but you can also do a great deal of work for your neighbors. You save money in the first place, and you earn money in doing the work for others. The important part is to get a reliable outfit that will not eat its head off in repairs. Take a look at our

TORONTO

Economy Sawing Outfits



You Will Be Independent!

The high price of coal or the high cost of labor will not bother you if you have one of these outfits, for you can cut up old rails and lumber for fuel, and you will not have to pay men to cut wood in the bush.

ASK FOR OUR SPECIAL SAW CIRCULAR

Ontario Wind Engine & Pump Co., Ltd.

Head Office - TORONTO
Branches - Montreal, Winnipeg, Regina, Calgary

FREE LAND

FOR THE SETTLER IN
New Ontario

Millions of acres of virgin soil, obtainable free, at a nominal cost, are calling for cultivation. Thousands of farmers have responded to the call of this fertile country, and are being made comfortable and rich. Here, right at the door of Old Ontario a home awaits you.

For full information, as to terms, regulations and settlers' rates, write to:

HON. JAS. S. DUFF, Minister of Agriculture
H.A. MACDONELL, Director of Colonization
Parliament Buildings, TORONTO, ONT.

MAKE YOUR BIKE A MOTORCYCLE

at a small cost by using our Attachable outfit. FITS ANY BIKE. Easily attached. No special tools required. Write today for our **FREE BOOK** giving list and free book. Describing the SHAW Bicycle Motor Attachment. Motorcycles, all makes, new and second-hand, \$30 and up.

SHAW MANUFACTURING CO.
79 Dept. Galesburg, Kansas.

Build Concrete Silos

Any size with the London Adjustable Silo Turbs. Over 9,000 concrete silos built in Ontario with our Silo Turbs. Send for Catalogue No. 10. London Concrete Machinery Co's, Limited, Dept. B, London, Ontario. Largest Manufacturers of Concrete Machinery in Canada.

CUT THIS OUT

Farmer's Advocate Pen Coupon, Value 4c.

Send this coupon with remittance of only \$1.52 direct to the Fleet Pen Co., 119 Fleet Street, London, England. In return you will receive by registered post, free, a splendid British-made 14ct. gold nibbed, self-filling, Fleet Fountain Pen, value \$4 (16s. 6d.). Further coupons, up to 13, will each count as 4c. off the price, so you may send 14 coupons and only \$1. Say whether you require a fine, medium or broad nib. This pen is made to introduce the Fleet Fountain Pen to Canada. Over 100,000 have been sold in England. Agents Wanted. Liberal Terms.

Monarch Gasoline Engines

1 1/2 to 35 Horse Power

Grain Grinders, Ensilage Cutters, Saw Frames and Pump Jacks



1 1/2 H.P. Horizontal Hopper Cooled

This engine built specially for small jobs around the farm and in connection with our intermediate pulley takes care of the churning, washing, pumping, etc. Being mounted it is easily moved from place to place.

Canadian Engines Co. Ltd., Dunnville, Greenock, Nov. 1, 15.

Dear Sirs,—I bought from your agent Mr. Roe a six H.P. Monarch Engine. I have had it two seasons and I ran a chopper, corn blower, corn blower and also a threshing machine; this engine has given me great satisfaction as I think there is no engine on the market will equal it.

Yours truly, J. G. Carter

Write for catalogue and prices to—**Canadian Engines Ltd., Dunnville, Ont.**
FROST & WOOD Co., Limited, exclusive sales agents east of Peterboro, Quebec and the Maritime Provinces.
Good live agents wanted in unrepresented territory.

LISTER GASOLINE AND GAS Engines

2, 3, 7 and 9 H.-P. ON SKIDS OR TRUCKS

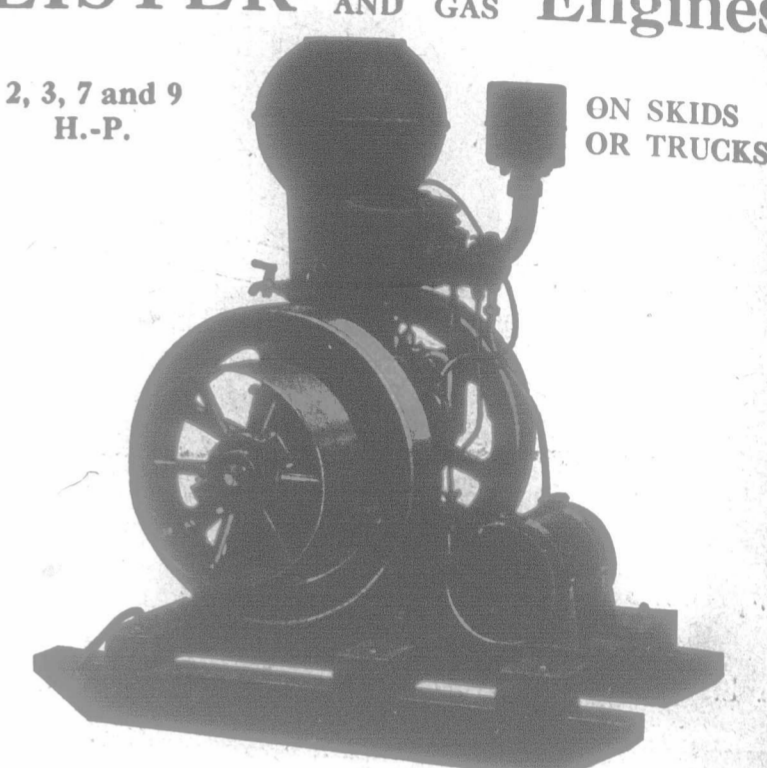

OVER TEN THOUSAND IN USE. Write for Catalogue "G." Lister Engines, Grinders, Threshers, Milling Machines, Electric Lighting Plants, Melotte Cream Separators.

R. A. LISTER & CO., LIMITED, TORONTO

Which Goes? His Weight or Yours?

Isn't it galling to have somebody tell you your declared weights are wrong? Never let suspicion fall upon the weight you give for your produce or live stock. Supply yourself with an absolutely reliable set of scales, and get the kind that can be used at all times and in all places. A patented feature of the Aylmer Three-Point support three-wheel, movable scale is that it will weigh accurately on an uneven floor or on rough ground. No other scale will do this.

Send for Illustrated Catalogue

We quote reduced prices, freight prepaid, to any station in Ontario to anyone ordering before January 1st, 1916.

Aylmer Pump and Scale Company, Limited

422 Water Street, Aylmer, Ontario

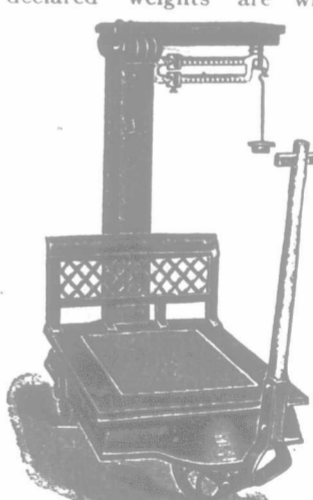

Gilson Engine

"Goes Like Sixty"



Anybody can operate the simple "GOES LIKE SIXTY" Engine. Ready for work the moment you get it. Built strong and solid to last a lifetime. Will give long, unflinching satisfaction. Gas, gasoline or kerosene can be used for fuel.

Gilson quality gives full value for your money—dependable service, great durability, highest economy and perfect satisfaction; freedom from trouble, delays and expense.

Every engine ABSOLUTELY GUARANTEED. You can try this engine on your own farm before getting for it. You take no chances.

The "GOES LIKE SIXTY" Line has an engine for every purpose. All styles and sizes from 1 to 40 H.P.

Write for catalogue.

Gilson Manufacturing Co., Limited
119 York Street, GUELPH, ONT.

Please Mention "Farmer's Advocate"

LINE GAS Engines

ON SKIDS OR TRUCKS



Catalogue "G." Lister Engines, Electric Lighting Plants, etc.

LIMITED, TORONTO

His Weight or Yours?

our let all... weight you give for your produce... Supply yourself with an able set of scales, and get the can be used at all times and in... A patented feature of the... free-Point support three-wheel... scale is that it will weigh accurate... even floor or on rough ground... scale will do this.

for Illustrated Catalogue... reduced prices, freight prepaid, station in Ontario to anyone... before January 1st, 1916.

r Pump and Scale Company, Limited... Street, Aylmer, Ontario

Wilson Engine "Goes Like Sixty"

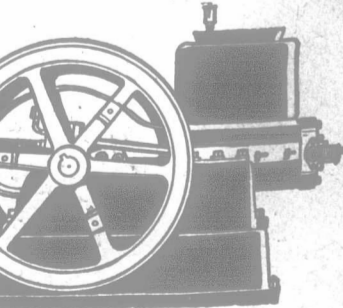

nybody can operate the simple "GOES LIKE SIXTY" Engine. Ready for work moment you get it. Built strong and... 1 to last a lifetime. Will give long... lling satisfaction. Gas, gasoline or... esene can be used for fuel.

lson quality gives full value for your... ey—dependable service, great durabil... highest economy and perfect satisfaction;... dom from trouble, delays and expense... very engine ABSOLUTELY GUAR... FEED. You can try this engine on... own farm before settling for it. You... no chances.

he "GOES LIKE SIXTY" Line has... engine for every purpose. All styles... sizes from 1 to 40 h.p. Write for catalogue. son Manufacturing Co., Limited 9 York Street, GUELPH, ONT.

LOUDEN

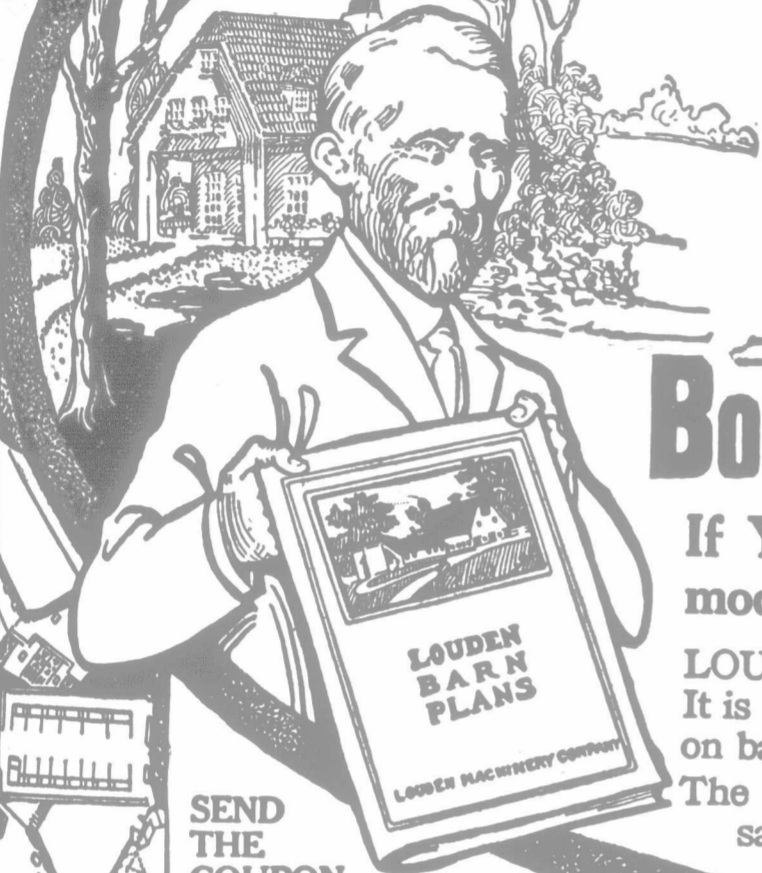

BOOK OF BARN PLANS FREE

If You Are Going to Build a New Barn or Remodel an Old One You Should Have This Book

LOUDEN BARN PLANS is not a catalog of barn equipment. It is a complete and valuable book of reference and instruction on barn construction.

The 96 pages of LOUDEN BARN PLANS are full of dollar-saving information—the best of the building ideas that the Louden Company has gathered during 48 years of barn-building and barn-equipment experience.

SEND THE COUPON

The advantages in each design in LOUDEN BARN PLANS are pointed out, and estimate of construction cost is given. In addition to the barn plans shown in the book, there are 32 pages devoted to general construction problems, such as concrete work, laying floors, roof construction, ventilation, etc.

LOUDEN BARN PLANS contains 51 representative designs for cow barns, horse barns, combination and general purpose barns, as well as many other designs for hog barns, pens, hay sheds, chicken house, etc.

When Writing For This Book Please State When You Expect to Build, and How Many Cows and How Many Horses You Want to House

WE HAVE DESIGNS FOR NEARLY 4,000 BARNs and our architects will give your letter personal attention if we learn your exact requirements.

LOUDEN BARN EQUIPMENT

Louden equipment makes possible a clean, sanitary barn with a minimum of expense for upkeep. When cows are transferred from dark, dirty barns

to Louden barns the milk flow often increases from 15 to 25 per cent, and the labor of caring for the herd is reduced from one third to one half. The cost of installing Louden equipment is surprisingly small, and is just as great an economy for the man with a half dozen head of stock as for the man with hundreds of animals. The percentage of labor saved is the same.

The Louden Line of Sanitary Steel Equipment Includes:

Litter Carriers Feed Carriers Milk Can Carriers Harness Carriers Hay Carriers Feed Trucks

Cow Stalls Horse Stalls Mangers Manger Divisions Feed Racks

Cow Pens Calf Pens Bull Pens Hog Pens Sheep Pens

Hay Loft Equipment Water Basins Bird Proof Barn Door Hangers Power Hoists, and Other Barn Specialties

CATALOGS FREE

Louden Machinery Company (Established 1867) Dept. 212 Guelph, Ont.



Please send me copy of Loudon Barn Plans. I expect to build (or remodel) barn for _____ cows and _____ horses. Barn will be about x feet.

Name _____

P.O. _____

Prov. _____





Columbia Records

NOW READY! DECEMBER NOW READY!

JUST what you'd expect from Columbia! The newest, snappiest popular hits—dance music—fun by Bert Williams, Weber and Fields—instrumental novelties—operatic gems—and a constellation of Christmas descriptives. Your dealer wants to play them for you.

CHRISTMAS DESCRIPTIVES.

Toy Shop Symphony and Christmas Morning with the Kiddies (Prince's Orchestra), a talk-feast of the toys—just made for the kiddies Silent Night, Hallowed Night, and Oh Come All Ye Faithful, famous Christmas hymns. The Messiah (Handel) "Worthy is the Lamb," Oratorio Chorus, and "Attila" (Verdi), "Praise Ye," Columbia Trio.

CLASSIC AND OPERATIO.

Rinaldo (Handel), "Lascia ch'io pianga" (Ah, Let Me Weep), and Shadows (Carrie Jacobs-Bond), by Julia Claussen, mezzo-soprano Herodiade (Massenet), "Vision Fugitive," Seagle, baritone; and Damnation of Faust (Moussorgsky), "Chanson de la Puce" Love's Old Sweet Song and Ye Banks and Braes o' Bonnie Doon, by Corinne Rider-Kelsey.

SEMI-CLASSIC AND STANDARD.

Macushla and Mother Machree, Irish melodies by Hardy Williamson. Funiculi Funicula (Denza), Charles Harrison, tenor, and Columbia Stellar Quartette; and Estudiantina duet, sung by Grace Kerns and Mildred Potter. Underneath the Stars, and "Somewhere a Voice is Calling," Trios, with violin, cello and piano. You'll want these.

INSTRUMENTAL NOVELTIES.

Blue Danube Waltz and The Three Jewels, by the Royal Marimba Band. Kaiwi Waltz, and Honolulu Rag. exquisite Hawaiian Guitar melodies.

THREE GREAT COMICS.

Frank Tinney, England's greatest humorist—First and Second Record. "Never Mo'" and "Purpostus," by the "great and only" Bert Williams. Trust Scene and Restaurant Scene, by Weber and Fields, the Fun Kings.

REAL POPULAR HITS.

Bounce Me John, I've Rubber Heels On, and Beatrix Fairfax, Tell Me What To Do. Back Home in Tennessee, and I'm All Alone Listen to That Dixie Band, and On the Good Ship Whip-Poor-Will.



DECEMBER DANCE RECORDS.

It's So Temptin', and Que Voulez Vous Encore—two snappy one-steps. The Girl Who Smiles, and Sphinx—Waltz Back Home in Tennessee, and To Lou—two brilliant one-steps. The Globe Trot, and Remick Medley—two clever fox-trots.

Of course this is only a sprinkling of the splendid Columbia list. Get complete December Columbia Record List from your dealer or write

COLUMBIA GRAPHOPHONE COMPANY

Canadian Factory and Headquarters 365-367 Spadina Avenue, Toronto

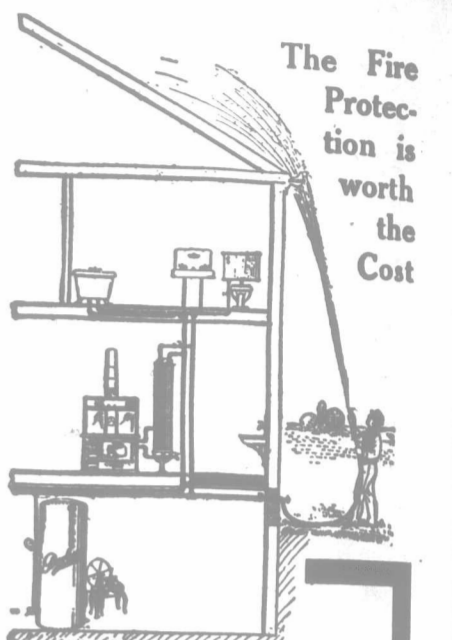

DON'T Keep the Women Waiting for WATER

Have pure water on tap throughout the house, gardens, barns. Let your wife have city conveniences—hot and cold water, a bathroom. Don't make her wait for water until one of the men come in. You will be astonished what a little it costs to

Install a PEERLESS Water System

Operated by hand, electricity or gasoline. Costs practically nothing to run. Water is pumped into an airtight tank in the cellar or outhouse. Then by the air thus compressed a fine pressure of water can be obtained at all taps—a stream of 30 to 80 feet high can be obtained with hose, in case of fire.

If you already have power, connect a Peerless pump and tank to it.

Let us send you full particulars. Our Engineering Department is glad of the opportunity to help you solve unusual problems. Write now to

NATIONAL EQUIPMENT CO. Limited
1 Wabash Ave., Toronto



She's Daddy's Girl-

The very sunshine of his life. He's planning great things for her—if he lives.

And if he dies—well, he's proud of the fact that she will then receive—regularly—each month—as long as she lives—a cheque from The Imperial Life to provide for her every need.

You can provide in this way for your little girl. Our free booklet tells all about it. Write for a copy. Address—

THE IMPERIAL LIFE Assurance Company of Canada

HEAD OFFICE - TORONTO

Branches and Agents in all important centres

Copyright 1916



Write for Our Special Offer Pays for Itself in 7 days

Mixing concrete with this 1915 Model Hand Mixer saves you time, labor and money. You get a better mix with less cement. Write for catalogues.

WETTLAUFER BROS.
Improved Concrete Machinery
78 ASpadina Avenue TORONTO, ONT.



CHALLENGE COLLARS

WATERPROOF ECONOMICAL ALWAYS DRESSY

NO EXPENSE FOR LAUNDRY BILLS

SO EASY TO CLEAN

MADE IN CANADA

DULL FINISH JUST LIKE BEST LINEN AT YOUR DEALER'S, OR DIRECT, for 25c

THE APLINGTON CO. OF CANADA LIMITED
54-56 FRASER AVE. TORONTO

FOUNDED 1866

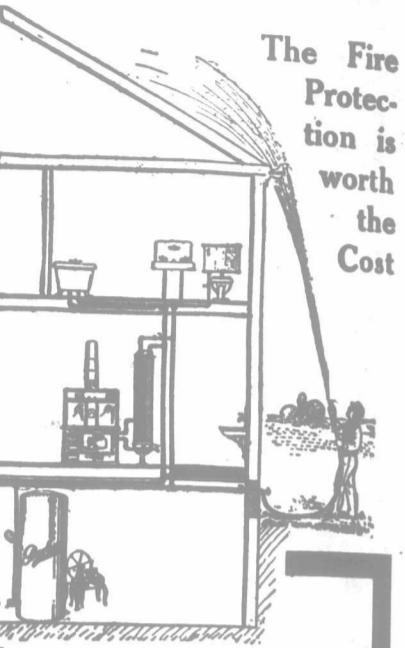

The Fire Protection is worth the Cost

DON'T Keep the Women Waiting for WATER

Have pure water on tap throughout the house, gardens, barns. Let your wife have city conveniences—hot and cold water, a bathroom. Don't make her wait for water until one of the men come in. You will be astonished what a little it costs to

Install a PEERLESS Water System

Operated by hand, electricity or gasoline. Costs practically nothing to run. Water is pumped into an airtight tank in the cellar or outhouse. Then by the air thus compressed a fine pressure of water can be obtained at all taps—a stream of 30 to 80 feet high can be obtained with hose, in case of fire.

If you already have power, connect a Peerless pump and tank to it. Let us send you full particulars. Our Engineering Department is glad of the opportunity to help you solve unusual problems. Write now to

NATIONAL EQUIPMENT CO. Limited
1 Wabash Ave., Toronto



Write for Our Special Offer Pays for Itself in 7 days

Concrete with this 1915 Model Hand Mixer saves you time, labor and money. You get a better mix with less cement. Write for catalogues.

WETTLAUFER BROS. Improved Concrete Machinery
Madison Avenue TORONTO, ONT.

CHALLENGE COLLARS

SO EASY TO CLEAN
MADE IN CANADA

WATERPROOF ECONOMICAL ALWAYS DRESSY
NO EXPENSE FOR LAUNDRY BILLS
DULL FINISH, JUST LIKE BEST LINEN
AT YOUR DEALER'S, OR DIRECT, for 25c

ARLINGTON CO. OF CANADA LIMITED
56 FRASER AVE. TORONTO

The Farmer's Advocate and Home Magazine

PERSEVERE AND SUCCEED ESTABLISHED 1866
REGISTERED IN ACCORDANCE WITH THE COPYRIGHT ACT OF 1875

Vol. L.

LONDON, ONTARIO, NOVEMBER 25, 1915.

No. 1209

EDITORIAL.

Regularity in feeding will save feed.

Many farm stables dismally groan for more light.

Round up the last of the farm implements and put them away.

Who is responsible when the plow is frozen in the ground in the fall?

Keep busy during the winter and utilize any leisure time and the long winter evenings in reading.

Have any precautions been taken to prevent mice and rabbits from girdling the young trees in the orchard?

The cobwebs in the stables have caught about all the flies they will this season and might well be swept down.

Rains hindered, but it has been a good or bad season largely according to the work and management of the farmer himself.

The "down" timber in the average farm woodlot may be used to cut the coal bill in half if not to cancel it altogether.

If you would have the stock winter well start them carefully on their winter rations and feed to maintain the grass fat on them.

Fresh, cool air in the stable does not mean discomfort if it is properly admitted and the foul air is carried off in the right channels.

The man who plans to feed his grain is not so tempted by high prices to sell as he was a year ago. One year with another it pays to feed.

Pigs cannot be successfully fattened in the barnyard in the cold weather, but the brood sows will be better outside until just before farrowing.

It's time to do some glazing around the buildings. A little putty and a few panes of glass mean comfort to the stock in place of drafts.

We have seen some good cattle in poor stables and some very inferior cattle in a regular stock palace. Breed and feed have something to do with it.

When a pig reaches the age and size for finishing he should get plenty of feed and that of a "strong" nature. There is no use attempting to "feed him along."

Judging from the note-writing proclivities of the United States, that country must be on the affirmative side of the old debate: "The pen is mightier than the sword."

We are all inclined to grumble a little from time to time that there is no war news, and yet we all know that the boys at the front are doing big things and making history every day that the war drags on.

Brevity and Common Sense.

Winter is naturally the season for conventions. It is a time when a day or two can best be spared to keep in touch with the new things that are constantly coming forward and to exchange ideas with others of the same fraternity. Farmers, fruit growers or horticulturists are not, however, so absolutely free of duties and labors in the winter months that they can afford to listen to personal reminiscences or lengthy addresses which sometimes, owing to their length, dissipate the interest that is at first taken in them. Conventions nowadays call for condensed papers worded in such a way that they can be interpreted by the listeners. Brevity and practicability should be the aim of every speaker. A subject may be intensely interesting to a few of a certain fraternity or profession, but the matter should be translated into common language in order that laymen may understand. It is all very well to work out details and make investigations in the world of science but if the discoveries have no practical bearing on farming it would be far better to record them to use for future reference. The farmer makes his living on the land and when he attends a convention he looks for information that can be taken back with him and put to use. Furthermore, it must be such that will directly or indirectly make him more dollars. Every speaker should first consider himself in the listener's position and censor his own remarks so they will all be of some value. While it is well to take time to make each point clear yet it is tiresome, aggravating, and poor policy indeed to speak too long or read a long paper. The creation of the world with its inhabitants both on land and in the sea, also its vegetation was described in less than 800 small words; at conventions we have often heard less important subjects discussed at five times that length.

A Discussion of Institute Work.

It seems that the re-organization of Farmers' Institutes in Ontario, as outlined in the notices sent out by the Superintendent early last June is not thoroughly understood by all those who are interested in the welfare of this work, or otherwise is not agreed with by some. Recently we received two letters from men in the same county asking that our columns be thrown open for a discussion of the change, and we are pleased to invite all those interested, including the men responsible for the re-organization scheme, to discuss the subject in all its phases through these columns. Readers will remember that last June, at the time the re-organization was first announced "The Farmer's Advocate" discussed it editorially at some length. Those who save their copies of this paper should turn back to the Editorial page in the issue of June 10.

Those who have followed Farmers' Institute meetings from year to year are agreed that interest has been gradually waning until during recent years the attendance dropped off very noticeably and newer organizations seemed to be gaining in favor. The reason for the proposed change is very well set forth in the following paragraph from our former Editorial:

"The object of the new organization is to secure the co-operation of all agricultural organizations, especially Farmers' Clubs, and representative men in each locality. This is necessary to stimulate interest in meetings. Fewer meetings than formerly will likely be held by the Institute or Board, but it is hoped that a large

attendance will be the rule and greater interest result."

The new organization is to be called a County Board of Agriculture, and it is hoped to develop local interest and bring the rank and file of farmers into closer touch with the most successful local men. This seems a good move, and if the new organization succeeds in accomplishing this it should prove a stronger factor than the old Institute. Outside men, not always familiar with conditions in the locality where they were sent to speak, and speaking to a set line of subjects did not always have subject matter which satisfied their hearers. And besides this the best men cannot always be induced to leave their farm business to undertake a series of meetings, and furthermore, it has sometimes been hinted that politics worked into the selection of speakers not always to the best interests of the Institute. This latter statement refers to conditions when either political party was in power.

We should be pleased to publish the views of some of those who have been connected with Institute work and are responsible for the change, and also of farmers who have attended Institute meetings in the past and have suggestions for the future of the new organization.

Is Lack of Lime the Reason?

The most common complaint heard among farmers regarding crops and cropping is the failure to get good catches of red clover. Smith, Jones, Brown and all the others have the same tale to tell: "If I could only get clover to catch regularly I would have little trouble in growing plenty of feed, in maintaining soil fertility, and following a set and suitable rotation of crops." But the clover fails, the feed supply falls, soil fertility diminishes and the rotation is upset.

Few of us really realize what the clover crop means to our agriculture. Failures are sometimes laid at the door of too little seed and most farmers sow too little seed. Ten or twelve pounds per acre, even though it is dear, is a safer seeding than five or six pounds per acre. Then too often it is sown on run-out land. After the farmer has taken all the fertility out of the field in cereal after cereal he says, "I'll seed that field down and make it up." But the seed does not catch and another cereal crop goes in.

But many fail to get a catch of clover even where plenty of good seed is sown on recently-manured land in first-class tilth and put in under a short rotation system, the best conditions possible. What is the reason? Are we safe in answering: lack of lime? Prof. Harcourt, of the O. A. C., from soil-survey work carried on during the past summer in several counties in this Province, tells us that it would appear that nearly all our soil might be improved by the addition of lime. We know that a sour soil will not grow clover. Is it possible that liming the soil would ensure uniform catches of clover even on soil not considered sour but deficient in lime? It would seem so. During the next few years lime seems to be destined to take an important place in the agricultural development of our Province, and nowhere is it more important than in the growing of clover. Try it out and if the soil answers that it needs lime apply it.

It will soon be out. What? "The Farmer's Advocate" Christmas Number, the anniversary issue of Canada's leading farm paper, fifty years old. Watch for it; read it; save it.

The Farmer's Advocate AND HOME MAGAZINE.

THE LEADING AGRICULTURAL JOURNAL IN THE
DOMINION.

Published weekly by
THE WILLIAM WELD COMPANY (Limited).

JOHN WELD, Manager.

Agents for "The Farmer's Advocate and Home Journal,"
Winnipeg, Man.

1. THE FARMER'S ADVOCATE AND HOME MAGAZINE is published every Thursday. It is impartial and independent of all cliques and parties, handsomely illustrated with original engravings, and furnishes the most practical, reliable and profitable information for farmers, dairymen, gardeners, stockmen and home-makers, of any publication in Canada.
 2. TERMS OF SUBSCRIPTION.—In Canada, England, Ireland, Scotland, Newfoundland and New Zealand, \$1.50 per year, in advance; \$2.00 per year when not paid in advance. United States, \$2.50 per year; all other countries, 12s.; in advance.
 3. ADVERTISING RATES.—Single insertion, 25 cents per line, agate. Contract rates furnished on application.
 4. THE FARMER'S ADVOCATE is sent to subscribers until an explicit order is received for its discontinuance. All payments of arrears must be made as required by law.
 5. THE LAW IS, that all subscribers to newspapers are held responsible until all arrears are paid, and their paper ordered to be discontinued.
 6. REMITTANCES should be made direct to us, either by Money Order, Postal Note, Express Order or Registered Letter, which will be at our risk. When made otherwise we will not be responsible.
 7. THE DATE ON YOUR LABEL shows to what time your subscription is paid.
 8. ANONYMOUS communications will receive no attention. In every case the "Full Name and Post-office Address Must be Given."
 9. WHEN A REPLY BY MAIL IS REQUIRED to Urgent Veterinary or Legal Enquiries, \$1.00 must be enclosed.
 10. LETTERS intended for publication should be written on one side of the paper only.
 11. CHANGE OF ADDRESS.—Subscribers when ordering a change of address should give the old as well as the new P. O. address.
 12. WE INVITE FARMERS to write us on any agricultural topic. We are always pleased to receive practical articles. For such as we consider valuable we will pay ten cents per inch printed matter. Criticisms of Articles, Suggestions How to Improve "The Farmer's Advocate and Home Magazine," Descriptions of New Grains, Roots or Vegetables not generally known, Particulars of Experiments Tried, or Improved Methods of Cultivation, are each and all welcome. Contributions sent us must not be furnished other papers until after they have appeared in our columns. Rejected matter will be returned on receipt of postage.
 13. ADDRESSES OF CORRESPONDENTS ARE CONSIDERED AS CONFIDENTIAL and will not be forwarded.
 14. ALL COMMUNICATIONS in reference to any matter connected with this paper should be addressed as below, and not to any individual connected with the paper.
- Address—THE FARMER'S ADVOCATE, or
THE WILLIAM WELD COMPANY (Limited),
London, Canada.

What Will They Do?

The criticism has been directed at the latest Royal Commission, created by the Dominion Government, that it represents strong financial, manufacturing and political interests rather than agriculture which is nominally recognized as the foundation industry of Canada. To its nine members has been assigned the task of taking stock of the country's resources and evolving plans for their development. Collectively they will naturally see things from their own viewpoint, which will hardly be claimed as that of the farm. But class contentions are idle. The Commission is arranged and at work. They may sincerely be desirous of seeing greatly increased population on the unoccupied and under-worked lands of Canada and a great after-the-war development, but are conditions to be made such that the man next the soil will receive an adequate, economic return or will greater production be simply a larger pawn in the hand of more powerfully organized interests? This is the gist of the problem they have to solve. Despite the hard-won progress made there is a deep-set conviction that for the labor, capital and intelligence which successful farming demands, and the risks involved the pursuit demands generally a more adequate return. The personnel of the Commission might well have included half a dozen representative farmers, but it could be just as seriously faulted for the lack of specific representation for the educational interests of the country. The lessons drawn from other modern nations certainly teach clearly and with growing emphasis that upon whatever extraneous helps manufacturing industries may rely, if there is to be substantial and permanent advancement, education, including training of a technical and industrial character, must be at the base. This then demands a foremost place in the plans of the country for the future, and in its outworking it will be more equitable than fiscal aids. Fortunately in this particular the Commission need not go far afield. There is at hand a fund of accumulated data awaiting further appreciation, viz., the results of the industrious research of a previous commission. There is now an opportunity to turn it to good account.

The world knows Canada well now, and a resort of artificial stimulants to immigration had better be discarded in any treatment prescribed for improving the future economic health of Canada. A natural inflow of healthy population will be best, and such a policy as will tend to

equalize the income-making opportunities of town and country. Speaking before the Canadian Club of Ottawa recently a well-known American author, Winston Churchill, admitted that the United States' policy towards Canada had been purile, but he added by way of explanation or suggestion that it had been dictated by and organized for the benefit of manufacturers, who, until recently, arranged tariff schedules to suit themselves, but there were signs now that this economic dictatorship was weakening.

Individually isolated as the farmer has so generally been from the nature of his holdings, his interests admittedly require safeguarding, so that for example, in the access to capital for furthering his operations he should relatively stand on a parity with enterprises of the town. What concerns him most of all is the profitable disposal of the products of the farm, and their reasonable and efficient transport to market so that an adequate income will be assured for his year's toil. Unless this is accomplished the drift toward will continue and the farm ranks will be further decimated by the terrific drains of the war upon our effective population. The hundreds already returning incapacitated for active occupations suggests some of the problems that will soon confront us as a people. It is not the often well-meant advice of townmen that farmers stand in need of—they have that in plenty from daily papers and platforms, nor yet to be flooded with government reports, however useful in their place. The farmer has ever been as ready as any class in the nation to avail himself of new and proved facilities. The development of Canadian agriculture during the past half century stands in proof of this. With the march and spread of general knowledge he may be trusted to "spruce up" and "broaden out" if the returns of his business afford the required facility and encouragement. Suddenly confronted with war administration the government has relegated what ought to be its own peculiar duty to the Development Commission, and if the latter succeeds in laying down with fidelity to the chief original producer and allied interests of the country, a really courageous and efficient program, the country has a right to expect prompt and effective action.

A Sane View.

The countless schemes that are being advanced to change or relieve "conditions" indicate that a large body of men in our cities apparently still believe that conditions are abnormal because they cannot live and increase their wealth by speculative methods and without actual work, and the persistence of this class in handing out its advice to farmers becomes distasteful not only because the advice is wholly unsound but because the men of the land know that they must support this class of people, know in fact that the whole commercial and financial system in Canada is supported by the industry of the men on the farm. In the midst of this clamor it is a relief to meet a really sane and constructive view on some matter emanating from our cities.

In an address before the Convention of Alberta Municipalities, G. R. Marnock, president of the Lethbridge Board of Trade, made some statements regarding the work of the organizations within his city that could well be copied. The trend of his address is well shown in his introduction, which reads as follows:

"No community can be entirely successful that does not proceed in the direction of seeking out what it may do on constructive lines to the advantage of itself and its neighbors. Our endeavors in Lethbridge have been largely in this direction, and the city and the board of trade have worked together, not only for what appeared to be for the immediate advantage of the city, but also for what appeared to be for our ultimate advantage. Having this before us we broadened our vision to take in our surrounding districts and our farming communities; for we recognized that if our agricultural foundations were not secure our efforts to improve our city would be in vain. Some of you good gentlemen may have heard it whispered lately from time to time that the development of our cities and towns was away ahead of our present requirements, and that the rural development, on the other hand, was lagging; that in fact, the cart was before the horse. We recognized that in Lethbridge about two years ago, and we have steadily endeavored since then to reverse that.

"The process has in no way taken the shape of teaching the farmer his business; if he doesn't know his business, certainly we city men are not likely to be able to tell him anything to his advantage—that would be too much like the blind leading the blind. I do not think we would be far wrong in saying that all we have done has originated in requests from the farmers themselves; and so long as a board of trade or a city proceeds on these lines they are likely not only to find plenty to do, but to be sure at the same time that they are doing what is wanted of them."

There is undoubtedly a big place in Canada for our urban centres. There is a tremendous

commercial and financial work to be carried on in connection with agriculture, and the commercial and financial interests can render to agriculture a very great service but it is not in the way of teaching better farming or attempting what some call "rural uplift work," but it is in rendering to agriculture an efficient, honest, and economic business service. When the Associations and Trade Organizations in our towns and cities place as their motto "service" to the people whom they call customers, then will more have been done to bring about prosperous conditions and dispel hardship in our cities and towns than any or all of the schemes that are from time to time being presented. The Board of Trade in Lethbridge seems to be leading in a sensible business way.

That this getting down to bed rock by the people of our cities in acknowledging that the sources of their revenue lie on the farm is not confined to any one city is indicated in a financial review of conditions at Moose Jaw. It is gloomily stated that a tax sale will be held in this city in which some 21,000 parcels of land, "mostly outlying lots, sold by subdivision artists in the palmy days," will be offered to the public. The review states that, having presented this rather depressing condition, that there is a more rosy side. From figures submitted by the Board of Trade it goes to show that in 1912 there were imported three carloads of poultry, six cars of butter, ten cars of eggs, thirty cars of bacon and fifty cars of potatoes, but there has this year been exported from the city eight cars of butter, fifteen cars of eggs, sixty cars of potatoes and very large quantities of bacon and lard and other products, together with millions of bushels of grain. They are looking to the farms. Three years ago the Boards of Trade in this city and in all our cities were attempting to establish automobile and other factories that could not possibly hope to live and were talking in terms of millions of dollars. To-day they are working to build up a trade through the cities of agricultural products and are evidently taking common sense. The tax sale is not going to hurt Moose Jaw nor will it hurt any other city if it cleans up a lot of outside subdivisions, helps to establish sane conditions within municipality affairs, directs the people's thoughts towards their real source of revenue and shows them their dependence upon agriculture.—"The Farmer's Advocate and Home Journal," Winnipeg, Man.

Natures Diary.

A. B. Klugh, M.A.

One of the groups of animals which are common in our lakes, ponds and rivers and yet about which very little is generally known is the Leeches, commonly termed "blood-suckers."

The Leeches are allied to the Earthworms, but are distinguished from them and from all other worms by the possession of a sucker at each end of the body.

Most of the Leeches live in fresh water, under stones, leaves and wood, on water-plants, in the mud and ooze on the bottom of ponds, lakes and streams, or attached to other animals. They can crawl about after the manner of the "measuring worms," using their suckers when thus moving about. They swim rapidly by flattening the body and progressing in a series of undulations. Many of the Leeches feed on the blood of aquatic vertebrates, such as fish and turtles. Some of the blood-sucking species remain attached to their hosts only long enough to become gorged with blood, while others spend most of their life attached to their hosts. Many other species of Leeches are either scavengers or are carnivorous in their food habits, the former feeding on dead animals, the latter on snails, worms, insect larvae, smaller Leeches, etc.

The mouth of a Leech is situated in the middle of the sucker on the head end, and in those species which suck blood there are salivary glands which produce a secretion that prevents the clotting of the blood which is sucked from the host. The alimentary tract (a name applied to the crop, stomach, intestine, etc., of animals when spoken of collectively) is quite different in those species which live on blood and in those which do not. In the former it has numerous side-branches, or elongated sacs, which act as reservoirs for the blood, while in the latter it is a straight tube. Because of the sacs mentioned above the blood-sucking Leeches are able to take in enough blood at a meal to last them for some time, often for several months.

Our Leeches have no organs of respiration, that function being performed entirely by the skin.

The Leeches are hermaphrodite, that is each individual possesses the organs of both sexes, but they are not self-fertilizing, as sperms are exchanged between different individuals, and the eggs are fertilized by the sperm received from the other individual. Some species lay their eggs in cocoons, or capsules, which they attach either to the underside of stones or to water-plants, while others carry the eggs and young attached to the

financial work to be carried on in agriculture, and the commercial interests can render to agriculture service but it is not in the way of farming or attempting what some call "light work," but it is in rendering an efficient, honest, and economic service. When the Associations and Commissions in our towns and cities place "service" to the people whom they serve, then will more have been about prosperous conditions and in our cities and towns than any other schemes that are from time to time proposed. The Board of Trade in Lethbridge is leading in a sensible business

getting down to bed rock by the cities in acknowledging that the revenue lie on the farm is not only one city is indicated in a financial conditions at Moose Jaw. It is said that a tax sale will be held in which some 21,000 parcels of land, including lots, sold by subdivision artists says, "will be offered to the public. It is stated that, having presented this condition, that there is a more liberal figures submitted by the Board to show that in 1912 there were carloads of poultry, six cars of eggs, thirty cars of bacon and potatoes, but there has this year from the city eight cars of butter, eggs, sixty cars of potatoes and quantities of bacon and lard and other things with millions of bushels of grain looking to the farms. Three Boards of Trade in this city and they were attempting to establish other factories that could not live and were talking in terms of dollars. To-day they are working through the cities of agriculture and are evidently taking common sense is not going to hurt Moose Jaw any other city if it cleans up a subdivisions, helps to establish a municipality affairs, people's thoughts towards their real estate and shows them their degradation.—"The Farmer's Advocate," Winnipeg, Man.

Natures Diary.

A. B. Klugh, M.A.
 groups of animals which are combs, ponds and rivers and yet about the is generally known is the only termed "blood-suckers."
 are allied to the Earthworms, which are found from them and from the possession of a sucker at the body.
 Leeches live in fresh water, under wood, on water-plants, in the bottom of ponds, lakes and attached to other animals. They can measure the manner of the "measuring" their suckers when thus moving swim rapidly by flattening the body. In a series of undulations. Leeches feed on the blood of aquatic animals as fish and turtles. Some of the species remain attached to their hosts and become gorged with blood. Many other species of leeches spend most of their life at the hosts. Many other species of leeches are scavengers or are carnivorous. Some, the former feeding on dead matter on snails, worms, insect larvae, etc.
 A Leech is situated in the middle of the head end, and in those species where there are salivary glands the secretion that prevents the clotting of blood which is sucked from the host. The name applied to the leech (a name applied to the intestine, etc.), of animals when they are (vividly) is quite different in those which are on blood and in those which are on other animals. The former it has numerous side-branches, which act as reservoirs, while in the latter it is a simple tube. Because of the sacs mentioned sucking Leeches are able to take a meal to last them for some several months.
 have no organs of respiration. The breathing being performed entirely by the body.
 are hermaphrodite, that is each has the organs of both sexes, but they are fertilizing, as sperms are produced by different individuals, and the eggs are received from the other. Some species lay their eggs in water, which they attach either to stones or to water-plants, while others lay their eggs and young attached to the

under side of the body until the young are able to shift for themselves. In the case of these latter species the eggs are laid in small, round clusters, each mass surrounded by a delicate membrane of a mucous-like substance secreted by the skin glands. A number of such clusters are somewhat loosely held together and are attached to the under surface of the body of the parent by a mucous-like membrane. When carrying eggs the parent does not move about much, but stays in some protected place and by gently moving the body keeps the eggs or young well aerated. If



Fig. 1.—Under side of Horse Leech.

the egg masses are dislodged the parent will make efforts to collect them and attach them again to its body.

A Leech which is very common in Canada is the so-called Horse Leech, shown in Fig. 1. It feeds on worms, various aquatic insects, snails and clams, and also on dead animals. It also sometimes sucks blood.

Another common species is shown in Fig. 2. This is the Snail Leech, a species which is remarkable for its great muscular strength, which enables it to overcome its prey and adhere to the under side of stones with great tenacity. It does little swimming and if disturbed is apt to roll itself into a ball. It feeds on snails and worms, and does not suck blood.



Fig. 2.—Under side of Snail Leech.—Life size.

Another species which is very common is the one which is parasitic on the Snapping Turtle and other Turtles. It feeds almost entirely on the blood of its host. It is olive-green marked with yellow, and in outline much resembles the Snail Leech though it is much larger, being from two to four inches in length. When carrying eggs it leads a free existence and feeds mainly on worms.

THE HORSE.

Feeding Horses Feeds of Poor Quality.

By reason of the long continued very wet season lasting practically from July first until well into September, a good deal of stock feed of all kinds is of poor quality. With the exception of hay that was saved in June it is practically impossible to get any that is of first-class quality. Hay of even fair quality is hard to obtain. On account of the weather a great deal of grass was allowed to stand until it became too ripe, and after being cut, being subjected to bad weather, it must, of necessity, be of poor quality. Straw is generally also of poor quality this season, and as a consequence of climatic conditions does not contain the usual amount of nutrition. On account of the high price of hay, even that of fair quality, there will be a great tendency on the part of the farmer to feed his idle or partly idle horses on that of poor quality and straw in order to market the hay that will sell. Hence it may not be considered out of place to give a word of warning and make a few suggestions regarding the feeding problems that confront the horse owner. The feeding of large quantities of roughage of poor quality to horses is dangerous. Feed that can be consumed in large quantities with practical impunity by cattle may cause serious trouble if given, even in limited quantities to horses. This, no doubt, is largely due to the comparatively small size of the stomach of the horse. The feeding of hay that is over ripe, dusty or musty in considerable quantities is very liable to cause digestive or respiratory diseases, or both. Some may ask "How can the quality of the feed affect the respiratory organs." This may be a reasonable question to ask, but when we understand that the stomach and lungs receive their nerve supply largely from the same pair of nerves, we can more easily appreciate the fact that when, from any cause, there is an often repeated or continuous irritation to the one, there is a strong liability of derangement of the other, through nervous sympathy. Most horsemen know that the continued feeding of dusty hay to horses, or an unlimited amount of hay of better quality to a greedy horse, is often followed by heaves.

No doubt we all remember that the summer of 1912 was very wet. And as a consequence feeding problems were almost as bad as they are now. Many of us will no doubt be able to call to mind the fact that during the fall and winter following the practicing veterinarians were kept more than ordinarily busy. We have on many occasions warned readers against making sudden changes in feed, especially to horses, and we wish to repeat the warning. From the reasons already mentioned there will soon be a tendency to change the feed of horses that will have a few months of idleness to straw or hay of poor quality. Where this change is made suddenly a considerable percentage of the horses usually show signs of digestive trouble in from one to two weeks. Where the change is made gradually by feeding a little less hay and a little straw at first and then gradually increasing the amount of straw and decreasing the amount of hay at each feed until in eight or ten days a full ration of



Preparing for the Parade.

A scene in the horse ring at Central Canada Exhibition, Ottawa, 1915.

straw may be given, we find that sickness seldom occurs. Where either the hay or straw that is being fed is either dusty or musty means should be taken to, as far as possible, avoid evil results. This can be done to a great extent by thoroughly shaking with a fork in order to remove all loose dust and then dampening with lime water before feeding. Where large numbers of horses are being fed this may appear to be too much trouble, but we must remember that the loss of a horse or the more or less serious impairment of one or more horses is more expensive than the necessary trouble in order to avoid such would have been.

Lime water is made by slacking a chunk of quick lime in a vessel, then pouring water into the vessel and stirring the fluid thoroughly, then allowing it to stand, when the undissolved lime will settle at the bottom of the vessel. The clear water on top is "lime water." It is simply a saturated solution of lime in water, i. e., all the lime that the water will hold in solution. It cannot be made too strong as the undissolved lime precipitates. A chunk of lime twice the

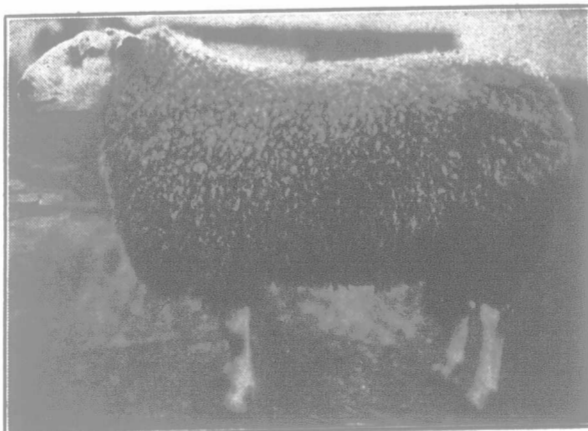

A Winning Leicester.

Champion Leicester ram at Toronto, 1915, for A. & W. Whitelaw, Guelph, Ont.

size of a man's fist is sufficient to make a barrel of lime water. It will keep pure a long time, hence may be made in large quantities and kept ready for use in a place where it will not freeze. Lime water should be used on all roughage, hay or straw that is of the nature under discussion. Grain of poor quality can also be rendered less dangerous if treated with lime water, but it would be still safer to boil it or get it rolled or chopped and treat with boiling water a few hours before feeding.

In order to winter idle horses cheaply there will be a great tendency on the part of many to feed silage. Silage of good quality fed in reasonable quantities, mixed with cut hay or straw or chaff gives excellent results, but we want to emphasize the fact, that in order that it may be safe for horse feed it must be of first-class quality. Silage that has not been properly made or has been subjected to frost or the surface of which has been exposed for considerable time tends to mould quickly.

Any feed that contains mould, and feed or

water that contains decaying animal or vegetable matter, mouldy silage, mouldy straw or hay, mouldy corn stalks, partially decayed roots, etc., if fed to horses in even small quantities for any considerable length of time will very probably cause a disease known as "Cerebro Spinal Meningitis." Dusty or dirty feed will not cause this. It is no doubt due to a germ or some microscopic object present in feed of the quality mentioned. It is a disease peculiar to equines. No successful treatment has been discovered for a case that is well established. Some cases evidently yield to treatment if given in the early stages, but a very large percentage of cases end fatally. In rare cases the symptoms appear suddenly and death occurs in a short time, but in most cases the symptoms develop slowly and the patient lives for a few days. The first symptom usually shown is an inability to swallow. When attempting to drink the animal apparently performs the normal acts: he keeps his lips in the

water, makes the normal sounds of a horse drinking but is not able to quench his thirst. If the water be in a pail or other small vessel, it will be noticed that the quantity is not becoming less, though he is apparently drinking heartily. He will masticate his hay or other food in a normal manner and make the ordinary noise of swallowing, but the masticated food will be either quid-ded or impacted between the molar teeth and cheeks. He cannot swallow. In a variable time, from one to several days, symptoms of paralysis will appear, he will lie or fall down and probably be unable to rise; delirium ensues and in from 1 to 3 days after the alarming symptoms appear he will die.

When a case of this nature is observed the cause must be sought for and removed. If due to the water, and pure water cannot be provided, that used must be thoroughly boiled. If due to food its consumption must be ceased. All horses that have been kept under the same conditions should be given brisk purgatives followed by 4 to 6 drams of hyposulphate of soda, or 40 to 60 drops of carbolic acid well diluted three times daily, and, of course, given feed and water of good quality. WHIP.

LIVE STOCK.

A Bright Outlook for Wool Growers.

The demand for wool seems to be increasing and sheepbreeders seem assured of good returns on this branch of their business. The following from a trade paper will interest sheepman.

"Sales of wool are progressing in all parts of the world which are producing centres of this material. There is one thing in common with all of them. This is that prices are everywhere high, in obedience to a very great demand. Accounts to this effect from South America, Great Britain, Australia and New Zealand, as well as from the various points in this country. Domestic wools have in general moved up 5 per cent. in price within a fortnight. Testimony as to the good condition of the industry in the extreme West is afforded in the call just issued for the eighteenth annual meeting of the Oregon Wool Growers' Association. The Secretary prefaces the notice with the statement that "the wool growers of Oregon have experienced the best year in the history of the organization." The high price of wool, combined with the scarcity and added cost of dyestuffs, has brought advances in price in woollen and worsted cloths. These advances concern the buyers less than does the question of their ability to obtain the needed goods. Clothing manufacturers are beginning to put in their orders for next fall, even before the formal openings, in order to make sure that they will be able to obtain needed supplies. Dress goods for the spring have been increasing in price as much as 10 or 15 cents a yard."

Someone prophesied that it would be six weeks from the first snow until winter sets in. We had the first snow in London, Ont., Nov. 15. If this prophesy holds true it will surely be an open fall, but it is well to be all ready for winter before it comes.

Results of Hog-Feeding Tests.

During the summer months the Ontario Department of Agriculture, through the various District Representatives, carried on, among the young farmers from the various short-course classes, competitions in "Feeding Hogs for Profit." These have been brought to a close and we believe have aroused no small amount of interest in hog feeding among the young men. There is something in the results for the older men too, and through the courtesy of I. B. Whale, B.S.A., Representative in Middlesex County, we are privileged to publish some of the figures regarding the competition as entered into by eight of the young men in the county where he is located. The pigs were all started in the race toward finished bacon at six weeks of age when they were valued at \$4.00 each, and the boys were allowed to select any breed or cross they preferred and to choose from the following feeds with the following set value per ton in all cases:

Ground oats, \$28.00; ground barley, \$28.00; ground peas, \$35.00; ground rye, \$28.00; ground wheat, \$35.00; bran, \$23.00; low-grade flour, \$32.00; shorts or middlings, \$28.00; tankage, \$46.00; green feed, \$2.00; skim-milk, \$5.00; buttermilk, \$6.00; whey, \$3.00; pasture, 75 cents per hog. The feeding period lasted sixteen weeks and when the test was concluded the hogs were valued at \$9.00 per cwt., fed and watered. The greatest profit per hog made by any feeder was \$9.39, and the lowest was \$1.00. The remaining six contestants submitted figures which ranged between the two extremes given and all recorded exactly the amounts of feed their pigs received.

The four pigs which returned a profit of \$9.39 each over and above the cost of feeding were given only shorts and whey during the first three weeks of their trial period in which time they consumed 120 lbs. of whey and 84 lbs. of shorts. They were then switched to a ration of equal quantities, by weight, of shorts and oat chop with whey added. After two weeks of such feeding or in their twelfth week they were turned to pasture and at the same time their quantity of chop was increased 2 lbs. and whey 10 lbs. During their 13th, 14th and 15th weeks they were fed oat chop and whey but in the 16th, 17th and 18th weeks they were again switched back to shorts and whey. At the beginning of the 19th week they were put on a ration of equal quantities by weight of oat chop and wheat chop and the whey was continued. This they received to the end of the twenty-second week or close of the feeding period. During the 16 weeks the four pigs consumed 381 lbs. shorts, 280 lbs. wheat chop, 449 lbs. oat chop, and 1,025 lbs. of whey. The total cost for these feeds according to the set values given to the contestants, is \$21.33 which includes \$3 for pasture and 30 cents for charcoal. Each pig, therefore, cost \$5.33 to feed for 16 weeks and each was worth \$4. at the beginning, making the total cost at the finish mount up to \$9.33. The average value of the finished hog at 9 cents per lb., fed and watered, was \$18.72, leaving a profit of \$9.39 each.

The lot of three pigs which returned a profit of \$1.00 each were fed chiefly on shorts. Throughout the 16 weeks they received 498 lbs. shorts, 156 lbs. oat chop, 85 lbs. clover and 367 lbs. milk. Each pig in this case would consume on the average 218 lbs. of grain and 122½ lbs. of milk. The pigs in the winning bunch would average 282 lbs. of grain and 256 lbs. of whey each. In addition to this they were on pasture for 11 weeks. The three pigs in the class which returned so small a profit totaled only 279 lbs. when 22 weeks old. The hogs were either poor feeders or they were not allowed enough feed.

A lot of four pigs which returned a profit of \$6.25 cents each were fed middlings and milk up to the 18th week when oat chop was added. For two weeks oat chop and middlings were used but at the beginning of the 20th week the latter feed was dropped and oat chop was increased and continued to the end. In all the four pigs consumed 519 lbs. middlings, 312 lbs. oat chop and 655 lbs. milk. Each hog on the average would receive 207 lbs. grain and 163 lbs. milk.

One other bunch of hogs gave interesting results in that they cost the most of any of the eight in the test. These four pigs consumed enough grain, milk and pasture during the 16 weeks, to make a cost \$8.58 each. They consumed 428 lbs. grain, and 722 lbs. of milk each, and at the conclusion of the feeding period averaged 200 lbs. in weight. These pigs were fed oat and barley and chop, then oat and wheat chop. After this they received oats and corn, then oats and barley and were finished on barley and rye. There is a considerable difference between the amount of grain and milk consumed by this bunch and those which were mentioned second in this article. The bunch of pigs which came at the foot of the list, so far as profits are concerned, cost only \$3.37 each to feed while this lot which we have just described cost \$8.58 each. Neither those which were fed the cheapest nor the most expensively returned the greatest profits. The most remunerative feeding was done at a cost of \$5.33 each for the 16 weeks.

Readers should bear in mind the fact that these profits are actual profits. Many farmers charge up on those feeds which are purchased in the form of meal or condiments, but in this case all the milk, whey, home-grown grains and even pasture are considered at approximately their market value.

Cattle Prices and Live Stock News From England.

There was a rare snap about the sale of Cruickshank Shorthorn cattle, bred by W. M. Cazalet at Fairlawne, Shipbourne, Tonbridge, Kent; and sold by John Thornton & Co. on October 26. Heifers of such old-time tribes as Clipper, Secret, Butterfly, Goldie, Augusta, Broadhooks, Jilt, Mayflower, Missie and Roan

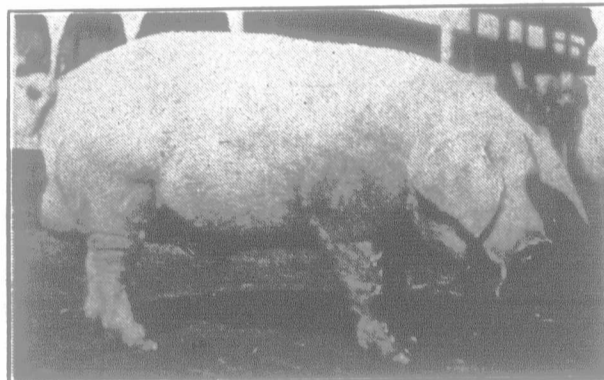

A Chester White Boar.

Champion at Toronto for D. De Coursey, Mitchell, Ont.

Lady were sold and they were also full of the blood of such noted Scots herds as Duthie's, Morrison's, Law's and Lord Lovat's. Captain R. J. L. Ogilby, an Irish breeder, spending a few days leave from the trenches in France, went up to 750 guineas for Fairlawne Clipper Queen, a light roan, out of Elvetham Clipper 3rd, and by Lord Lovat's bull Willie Campbell. This heifer, born May 3rd, 1913, has won at the Royal Show and at those exhibitions held in Lancashire, Norfolk and Leicester this year, and she came from a cow that cost 330 guineas and had thrown a bull that realized 400 guineas under the hammer at the Bristol Royal Show. Her back breeding runs to the Cinderella's and the Charmer's that made Amos Cruickshank's name famous among pioneer breeders. Capt. Ogilby also paid 330 guineas for the heifer calf Fairlawne Goldie 3rd, a dark roan by Collynie Grand Knight out of Gipsy Countess 3rd, and a big winner at south county shows. Here in back blood did the Cruickshank name crop up very frequently on the pedigree chart. All told, at this sale, 54 head averaged £114 4s. 9d. They aggregated £6,168 15s. Let it be

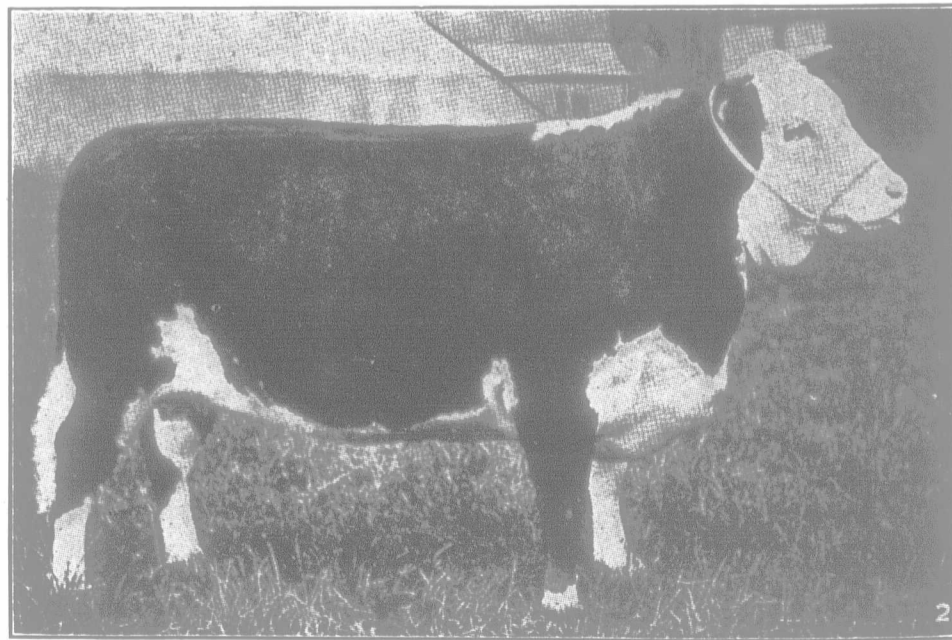

A Type of Hereford in Britain.

This female was sold to breeders in Argentina, where many high-priced animals are going.

added the 15 young bulls averaged £102 and the 39 heifers, many of which were yearlings fetched £118 apiece.

Next day the Edgcote Shorthorn Breeding Company at Banbury, Oxfordshire, held their fourth yearly sale and Argentine buyers were in great force. Sixteen out of the 36 young bulls offered went abroad and Edgcote Regalia, considered the best youngster ever bred by the Company realized 1,400 guineas, and again Captain Ogilby was the buyer. This bull is a handsome roan with a fine head and a grand loin, and is by Collynie Regal King out of Evelwyn, an Eliza cow. There were lots of bidders after him up to 1,000 guineas, and the gallant Irish

soldier beat off finally an Argentine who stopped at 1,300 guineas. The Casares family, who ship Shorthorns to the Argentine, bought many good looking sorts. Captain E. Brassey gave 650 guineas for a grand colored December calf by Ascott Clipper from a Missie cow, Mistletoe 41st. F. B. Wilkinson gave 400 guineas for an April calf by Collynie Marshall out of Clipper Belle, and a level and shapely sort. Now at this sale, which also represented the Cruickshank strains, 70 head sold at an average of £114 9s. 11d., and gave the breeders an aggregate of £8,014 13s. Here, however, the bull calves averaged £158 11s.

At a sale of beef cattle, bred on similar lines, at Darlington, Lord Lovat paid 420 guineas for a white bull calf of the Princess Royal tribe bred by C. H. Jolliffe.

Everyone might well ask how is it prices for beef stock have spurted so suddenly in England. There is a very good answer to the riddle and a rather extraordinary one. A few days before these particular sales were held, the Board of Trade announced that the Argentine Republic were agreeable to admit English cattle from subdivisions in all parts of Britain where such districts had been free from foot and mouth disease for a period of two months prior to the exportation of the cattle, and provided that the disease was not epidemic in other districts of the exporting area. Hitherto, the Argentine had not allowed cattle to land in its ports until a period of six months had elapsed since the last outbreak of the disease in the whole of Britain.

The concession was widely welcomed by British breeders of pure-bred stock (and as will be noted particularly the Shorthorn men), for the new regulations in effect meant no real hindrance to the English export trade, though a vagrant case of the dread disease might appear in some corner of the country. These regulations had just met a demand which breeders had been clamoring for for a long time, and they gave exporters greater confidence. So, they went forth to buy, when lo and behold, in Western England and in South Wales, suddenly an outbreak of foot and mouth disease was discovered by the Board of Agriculture and tackled with great promptitude. But the news of the disease reached the Argentine and that country wired to England 24 hours after the Edgcote sale that owing to the appearance of foot and mouth disease in Great Britain, the Argentine Government has decided to prohibit the importation of cattle from that country.

So, all the dreams have vanished; so, British breeders are down in the mouth again and Ireland—Ireland, undoubtedly the cause of all the trouble—escapes free! What a game!

Apropos of the "boom" in cattle prices in Britain, of which I have already written, it is perhaps worth while recording that Scotland has had a fine season with her sales of pedigree cattle. During the year 1,403 Shorthorns have been sold at public auction in Scotland for £72,783 18s., or at an average of £51 17s. 6d.; or 2s. 2d. less than the average of 1914. The 1915 bull average was £4 down on the year, but the cow average £13 up, while heifer calves in 1915 sold at £55 17s. per head against £46 in 1914.

Breeders of Aberdeen-Angus have done very well indeed. For the 1,613 head sold by auction in 1915 an average of £80 2s. 1d. was secured or an aggregate of £48,563 7s. 7d. The 1914 average was £29 6s. 11d.

Taking both breeds together, 3,016 head have averaged £40 4s. 8d.—exactly the figure of 1914—and the aggregate has meant

the turnover of £121,347 5s. 6d. So far as the Shorthorns are concerned, the year's average of £51 17s. 6d. is one of the best since 1906.

Aberdeen-Angus men should take heart of grace from the fact that their average of £80 2s. 1d. is the best since 1882.

In Lincolnshire recently that splendid dual-purpose breed, the Lincoln Red Shorthorn, sold at an average of £43 5s. 7d. for 41 head.

At Kingham, Gloucester, John Thornton & Co. have sold 498 head of utility Shorthorns this year at an average of £36 4s., or an aggregate of £18,027.

I have been going through the death roll of

off finally an Argentine who
1,300 guineas. The Casares
ship Shorthorns to the
bought many good looking sorts.
Massey gave 650 guineas for a grand
ber calf by Ascott. Clipper from a
stletoe 41st. F. B. Wilkinson gave
for an April calf by Collynie
of Clipper Belle, and a level and
Now at this sale, which also re-
Cruikshank strains, 70 head sold
of £114 9s. 11d., and gave the
regate of £8,014 13s. Here, how-
calves averaged £158 11s.

of beef cattle, bred on similar lines,
Lord Lovat paid 420 guineas for
alf of the Princess Royal tribe bred
ffe.

ight well ask how is it prices for
e spurred so suddenly in England.
y good answer to the riddle and a
rdinary one. A few days before
r sales were held, the Board
ced that the Argentine Republic
to admit English cattle from sub-
l parts of Britain where such dis-
a free, from foot and mouth disease
two months prior to the exportation
attle, and provided that the disease
nic in other districts of the export-
therto, the Argentine had not
to land in its ports until a period
had elapsed since the last outbreak
in the whole of Britain.

ion was widely welcomed by British
re-bred stock (and as will be noted
the Shorthorn men), for the new
effect meant no real hindrance to
port trade, though a vagrant case
disease might appear in some
country. These regulations had
demand which breeders had been
for a long time, and they gave ex-
confidence. So, they went forth
o and behold, in Western England
Wales, suddenly an outbreak of foot
eas was discovered by the Board
and tackled with great prompt-
e news of the disease reached the
that country wired to England 24
Edgcote sale that owing to the
foot and mouth disease in Great
rgentine Government has decided to
importation of cattle from that

dreams have vanished; so, British
own in the mouth again and Ireland
doubtedly the cause of all the
s free! What a game!

the "boom" in cattle prices in
ich I have already written, it is
while recording that Scotland has
son with her sales of pedigree cat-
the year 1,403 Shorthorns have been
sold at public
uction in Scotland
for £72,783 18s., or
at an average of
£51 17s. 6d.; or 2s.
2d. less than the
average of 1914. The
1915 bull average
was £4 down on the
year, but the cow
average £13 up,
while heifer calves in
1915 sold at £55
17s. per head against
£46 in 1914.

Breeders of Aber-
deen-Angus have done
very well indeed. For
the 1,613 head sold
by auction in 1915
an average of £30
2s. 1d. was secured
or an aggregate of
£48,563 7s. 7d. The
1914 average was
£29 6s. 11d.

Taking both
breeds together,
3,016 head have
averaged £40 4s. 8d.
—exactly the figure
of 1914—and the
aggregate has meant

£121,347 5s. 6d.
the Shorthorns are concerned, the
of £51 17s. 6d. is one of the best

Angus men should take heart of
fact that their average of £30 2s.
t since 1882.
shire recently that splendid dual-
the Lincoln Red Shorthorn, sold
of £43 5s. 7d. for 41 head.
n, Gloster, John Thornton & Co.
8 head of utility Shorthorns this
verage of £36 4s., or an aggregate

going through the death roll of

famous sporting men killed at the war, and I find
that quite 1,000 noted hunting men, those
genuine sports who patronize farmers over whose
land they hunt with the trade in horses and
provender, have gone down nobly fighting the foe.
Seven masters of hounds have been killed, and
over 160 other masters are in the trenches.
These masters have had their stables denuded of
riding horses and it is only with the greatest
difficulty that old hunt servants left behind can
get mounts to take out hounds for exercise.

The Earl of Feversham is raising a farmer's bat-
talion for the front. They are training in Yorkshire
and farmers and their sons are valiantly enlisting
and doing their preparatory drills with great
vigor. In Napoleon's days the farmers of Eng-
land made Britain's best "sodgers" and their
grandsons are now filling their right niche in the
edifice of the great British army.
London, Eng. G. T. BURROWS.

Clean Up and Disinfect the Stables.

It appears that live-stock is not so immune to
infectious troubles as it was years ago. Con-
tagious diseases now constitute one of the great-
est obstacles to successful live-stock breeding, and
stockmen must awaken to this fact, for sooner or
later some epidemic is liable to appear in the
community and the healthy herd or flock main-
tained with sanitary environments is in a better
position to escape than is the herd managed in
an out-of-date and primitive manner protected by
no precautionary measures. When the causes for
contagious troubles were first being investigated,
when germ life was being studied and efforts be-
ing made to associate it with diseases of live
stock, disinfection might have been termed scien-
tific, but to-day we know for a certainty that
germ life is responsible for the majority of
troubles in the herd, and with the knowledge that
stockmen have to-day regarding diseases they can
combat them quite successfully by purely prac-
tical methods.

There is no time of year that demands a
thorough cleaning-up of the stables and pens more
than does the fall when the young stock is being
brought in from their free range in the fields and
pasture. There is nothing quite so aggravating
as to see the stock infested with lice, mange, and
other troubles which spread quickly in the stables.
Tuberculosis, contagious abortion and other
scourges greatly reduce the profits of the stock-
man. The germ life which causes most of these
troubles are harbored in the dust, cobwebs, cracks
and crevices about the stables. A clean-up day
is in order at this season of the year.

There are two stages in thorough cleaning and
disinfecting. First, all refuse and debris should
be cleaned out, cobwebs and dust should be
brought down, floors should be scraped and all
litter removed. Unless this be done first fluids or
liquids which carry the destroying agents into
the cracks and crevices where the disease germs
may be lurking will not strike the mark. The
second stage of the operation consists in making
a preparation that is a thorough disinfecting
agent and applying it successfully. Whitewash is
useful in two ways. It may act as a medium to
convey a disinfectant and it also has disinfecting
and purifying properties itself. Stables which
are not painted would probably look better after
a good application of whitewash and in it a 5
per cent. solution of crude carbolic acid or a 2
per cent. solution of cresol would be effective, but
there are other coal-tar products such as a cheap
creolin, zenoleum and others which may be used
with quite as good results. These preparations
may be applied with a large brush, but this is
rather a slow process when the whole stable is to
be gone over. The majority of farms nowadays
have some sort of spraying apparatus; there is
surely one in the community that may be
borrowed for the purpose. Where whitewash is
being used strain the preparation through a fine
sieve and apply with the hose, using as much
force as possible. Cover every spot, get the
liquid into every crack and crevice. After the
operation is completed wash out the mangers and
feed boxes. Sunlight is a disinfecting agent we
have not yet mentioned. It is the cheapest one
of all. Every stable should have an abundance
of fresh air and sunlight.

Watch the herd for lice. If vermin of this
kind be present use some commercial powder or
lice killer or apply a mixture of 1 part hellebore
to 4 parts of cement. Work it well into the hair.

Good Business.

The following note of appreciation will in-
terest our advertisers and readers generally. It
is from one of recent advertisers of a live-stock
sale:

"We are well pleased with the advertisement
and feel that it will reach a class of men that
we otherwise would not have reached. Your
representative visited us this week and found
things as represented and in good condition.
We wish you continued success with 'The Farm-
er's Advocate.' It has come to our home ever
since it started, and we have some of the oldest
issues in the house at the present time."

R. & A. W. OLIVER.

Markets Versus The Sheep Industry.

Editor "The Farmer's Advocate":

Following what has already been written in
the columns of "The Farmer's Advocate" in re-
gard to the present market demands and their
probable effects on the sheep-breeding industry, a
few remarks may be in order. You inform us
that buyers in Toronto require sheep and lambs
of so light a weight that it would be impossible
to produce lamb or mutton in marketable condi-
tion at the weights mentioned, lambs from 78 to
85 lbs., and mature sheep at from 110 to 135
lbs. A lamb of any of the larger breeds at that
weight would consist merely of skin and bone,
and in the same class of stock the mature sheep
even at the maximum weight mentioned, 135 lbs.,
would also be an impossibility, as any sheep of
the larger breeds fit for the butcher must greatly
exceed that weight.

In these circumstances the breeder of this class
of stock must look around and find whether this
demand for small mutton and lamb is purely
local. If in other markets the taste and require-
ments of the public is for the class of mutton
and lamb he is in a position to supply his pro-
duce can be sent to these markets. No farmer
can afford to be constantly changing his stock,
nor could any good result be expected from his
doing so except under pressure of circumstances.
It is in all cases more practicable for a man who
has spent years in perfecting his chosen breed of
sheep to change his market than to change the
class of stock he has been accustomed to handle,
and of which he has a knowledge and a liking.
The work of years should not be lightly undone.
It is far easier to pull down than to build up
again. If, however, the present market demand
is uniform, I might almost say universal, and my
own observation leads me to that conclusion, the
question resolves itself into whether the breeder
will ignore the market or capture it.

One of the first doctrines of economics is that
the supply of any commodity must be regulated
by the demand. No manufacturer, for instance,
would think of continuing to produce an article
he could not sell, though in former years he may
have made a fortune by the self-same article. He
sets out at once to find what the public demands
and at once begins to produce it to the best of
his ability. So it must be with the breeder of
stock. If he finds there is no demand for his
special class of animal, however much he may
admire it, he is bound to change or at least
modify his methods. In Great Britain the high-
class trade has always run to the smaller breeds
of sheep, by preference to the mountain breeds,
but there has always been, and I expect the de-
mand will continue, a good market for mutton
of heavy weight and not so fine a texture in the
mining districts and manufacturing centres of
the country. Owing to the farming conditions
there will also always be a demand for pure-bred
rams of good size for crossing purposes. Hence
the future of this class of stock is secure in the
English market. If such a situation arose in
Canada it would, of course, be our duty to meet
it by producing the class of stock required. Our
conditions, however, are different and are not
liable soon to change.

Our present duty is to produce a larger sup-
ply of sheep and lambs such as are required for
a high-class trade. A sheep not too heavy for the
taste of the community with small bone and
carrying its flesh evenly is what is wanted
here. On agricultural farms we require a breed
which will mature quickly and so make a speedy
turnover of capital. A visit to the show yards
of the country may suggest the kind of sheep
most suitable. Until more farmers can be in-
duced to add a flock of breeding ewes to their
stock we cannot look for much improvement in
our market for mutton. If they only could be
brought to see how profitable a small flock of
sheep can be made at little more than the initial
cost of the animals the mutton market would at
once be placed on a satisfactory basis. And the
farmer would prove for himself the truth of the
saying that "Cattle are silver and sheep are
gold."

The butcher and personal observation of the
retail trade tell us that lamb is much more in
demand than mutton. This may easily be ac-
counted for as everything which can possibly be
called lamb is sold as lamb. Owing to the
quite inadequate supply of sheep bred much of the
mutton placed on the market consists of ewes
which being past usefulness for breeding purposes
from old age or other disability are fattened for
the butcher. The natural result being that the
retail buyer after one or two experiences says
that mutton is "tough" and has a "strong"
flavor and consequently always demands lamb. If
we can produce mutton of suitable age and good
quality this will be altered. This matter is
in our own hands. In my idle moments I have
at times meditated on the rejuvenating influences
of the cold-storage system. I have seen many
small-sized sheep of uncertain age and not of the
best quality sold in the markets of the country.
Where do these animals go? Judging from the
appearance of "spring lamb" on some of the
tables of our country a suggestion has come to

me for the solution of this great problem. Pre-
sumably they enter those modern Elysian fields
and forgetting their former cares of motherhood
and the vicissitudes of life emerge in due season
as the above mentioned "spring lamb." Perhaps
this idea is due to our unduly suspicious disposi-
tion, let us leave it at that.

ROBT. McEWEN,
Pres. Dom. Sheep Breeders' Assn.

FARM.

Why Some Men are Honest.

Editor "The Farmer's Advocate":

I was listenin' tae some auld chaps arguin' a
few days ago about the reason some men were
honest. One o' them pit it this way, says he,
"gin it werena' for the law there wouldna' be
mony honest men in the world. That is what
the law was made for, juist tae keep them
straight. Somebody wha kenned he wisna'
honest himsel' an' haein' a pretty guid idea that
ither men were like him in that respect, proposed
passing a law that ilka mon that was proved tae
be guilty o' a dishonest act should be punished.
Ither men thinkin' it wad no' look weel for them
to oppose sic a move for reform agreed tae the
thing, an' it was made a law. Noo we have tae
be fairly honest or go tae jail. That's about a'
that keeps us frae haein' oor hand in oor neebor's
pocket ilka chance we get."

The ithers wha were mstenin' seemed tae agree
with this view o' the case, but it didna' seem
altogether right tae me, an' I got tae thinkin'
it over that nicht as I wis sittin' by the stove
afore goin' tae bed. "Noo," says I tae maseel',
"let us take a look at the mather an' see gin
there's ony truth in the idea that it's fear o' the
law that keeps men frae being crooked. For gin
it is," says I, "it's a poor sign o' humanity.
They're straight because they have tae be, an' no'
because they want tae dae what's richt. They're
afraid that gin they steal one dollar it may cost
them twa tae fix it up, gin they are found out.
They must hae got tae the point where their con-
science has gone oot o' business, as na' doot it
will, gin a mon keeps chokin' it off a' the time."

"But noo," thinks I, "what dishonest things
have ye seen in yer ain experience, an' heard tell
about, that will throw ony light on this subject
o' mon's tendency tae try tae get somethin' for
naething. Weel, for an instance, there was the
time I was sellin' potatoes in the fall o' the
year an' drawin' them straight frae the field tae
the toon. One o' ma neebors cam' along while
I was fillin' the bags an' stood watchin' me for
a while. I wis throwin' some o' the potatoes
tae one side an' he says tae me, "Sandy, for
why dae ye do that?" "They're rotten," says
I. "But they dinna' show it over muckle," says
he, "the chap ye're sellin' them tae wad never
notice it."

Another time I was drawin' wood tae a party
in toon an' on ma way hame a chap that was
warkin' at the same job as mysel' caught up tae
me, an' got on the sleigh wi' me tae hae a chat.
When he had found out where I was drawin' the
wood an' hoo muckle I was gettin' for it an' a'
the rest o' it, he says tae me, "Sandy," says he,
"I've found oot a way tae get even wi' these
folks that we're sellin' wood tae, that winna' gie
us enuch for it tae pay for oor salt. Juist pit
the sticks in the bottom row o' yer cord about
sax inches apart. Ye'll be surprised what ye'll
save that way, an' they'll never notice it," says
he.

About a year after this I was killin' a beef
for mysel' one day, an' I had a mon wha lived
in the neeborhood part o' the time in tae help
me. He was a sort o' handy-man an' we got
him for a' sorts o' odd jobs. As he said him-
sel' he had learned a' sorts o' tricks an' trades
in his travels. Weel, aifter we had got the coo
skinned an' hung up this chap takes hauid o' the
hide an' draws it ootside an' spreads it oot on
the snaw. Then he took a pail o' water that
was standin' by an' threw it a' over the hide.
"There," says he, "in aboot ten minutes that
water will be pretty well frozen on a day like
this. Then we'll roll the hide up an' gin ye sell
it afore it thaws oot ye'll mak' aboot a couple
o' dollars oot o' one pail o' water." "Weel,"
says I, "if that's one o' the tricks ye've learned
in yer travels ye'd better quit travellin' an' stay
at hame for a while. Ye're gettin' tae ken over
muckle, entirely." "Hoot man," says he, "the
chap ye sell the hide to will never notice it."

Noo here was three cases where it looked as
though the men wha were up tae crookedness
were daeing it because they didna' expect tae be
found out. Gin we were tae judge humanity by
these samples o' it the only conclusion we could
come tae wad be that it's the law that keeps us
as honest as we are. But there's another side
tae the case, I'm thinkin'. Gin there isn't we're
a poor lot, the hale o' us, an' the world maun
be gaein' tae the dell entirely.

What about the best men ye ken in yer neebor-
hood, or that ye've heard tell about in ony coun-

try, or in the world for that matter? Did they no' hae the same chance tae be dishonest, without being found out, as the rest o' mankind? There's na doot about it, but they thocht o' ither things than juist what man's law wad dae tae them, or wouldn't dae, gin they were smart enouch. They thocht o' the future, o' twenty or feerty years ahead when they wad hae tae reap what they had been sowing, no mairther whether anyone besides themselves kenned aboot the weeds in their seed grain or no'. In ither words the actions that went tae build up their character were clean and honest, whether they were dealing wi' the world or wi' themselves, an' they were clean an' honest because they kenned that in the lang rin there's na ither way tae happiness an' peace o' mind. An' say what ye like, these are the twa things that humanity has been chasin' these guid many thousand years. Money or onything else is only at best a means tae this end, as we can see, of course, when we stop tae think aboot it. Tak' a mon like Gladstone for instance. Dae ye think it mattered tae him what the law was on ony question he had tae decide? It was juist a case where what he believed tae be richt made him decide against what he thocht was wrang. An' there are thousands o' the best men o' the world that are guided by their conscience, an' the wish tae mak' the maist o' their lives, that dinna' gie a second thought tae what the law has tae say aboot this or that. For we can mak' laws tae protect oorselves against the crookedness o' ither, but we canna' mak' laws tae protect us frae being dishonest wi' oorselves. Not an' get them pit on the Statute Boo's onyway. Gin we want tae hae onything at the end tae pay us for a oor trouble in gettin' through this world we want tae keep straight, no matter what the laws may be. There is na credit in daein' richt juist because ye canna' get the chance tae dae wrang. What like chap did Robbie Burns hae in mind, dae ye think, when he said,

"The honest man though ere sae poor,
Is king o' men for a' that."

Gin ye ask me I dinna' think he was referin' exactly tae the kind o' gentlemen who keeps one eye on the policeman while his hand is in the ither fellow's pocket.

Auld Robbie could aye strike the nail on the head when he took tae moralizin', though he used tae rin out o' the "straight an' narrow way" once in a while himsel'. Maybe that's why he could talk sae muckle tae the point. I've seen preachers o' that kind afore noo. They ken where tae hit. Even when they get tae talkin' aboot dishonesty. SANDY FRASER.

The Farming Special.

As announced in a previous issue of "The Farmer's Advocate" the Ontario Department of Agriculture have been running a farming special over the lines of the C. P. R. during the past few weeks. While the train carried very little new material as compared with that shown on other like trains in past years those people living adjacent to the C.P.R. line and close enough to the various stops to be able to visit the demonstration were well repaid for time spent both on the train and at the meetings held in the evening.

A representative of this paper visited the train at one of the stops in Middlesex County and found a very good crowd present, and considerable interest shown in the various subjects taken up by the specialists in charge of the various departments represented in the exhibits. One coach of the two which composed the train was given over to live-stock work and carried two horses, three cattle, and eight sheep. Those responsible for the demonstration stock were certainly fortunate in securing a Clydesdale filly and a Percheron filly, winners at the recent Canadian National Exhibition, and two of the real good ones of their respective breeds. The cattle comprised a Holstein, an Ayrshire, and a milking Shorthorn cow, while the sheep were Shropshires and Cotswolds, representing the medium-wool breeds and the long-wool breeds. The talks on stock and stock breeding, with the animals on the ground as a demonstration, proved the best drawing card.

In the other coach were to be found exhibits of weeds and seeds, poultry appliances, dairy utensils, the various types of lightning rods, and drainage tools and plans, and exhibits of grains, etc., from the Field Husbandry Department of the O. A. C. Those in charge of the exhibits were ready and willing to answer questions regarding any of these branches of agriculture.

These demonstration trains have been described several times in "The Farmer's Advocate" and there is very little new to be said about them. However, they are still doing a good work and people living in a district visited by the train should not fail to spend at least an afternoon listening to the demonstrators and looking over the exhibits. If those in charge of the planning of routes for the trains change the stopping places from year to year this feature of agricultural educational work should not very soon wear thread bare.

A Stook Thresher Used In the West.

To the man who has lived and farmed east of the Great Lakes the operations of the grain grower in the West appear extensive indeed. Machinery propelled by gasoline or steam is doing the work of many men, and without such power a crop approaching the 300,000,000-bushel mark would not have been possible this year. On the extensive grain farm or ranch large and heavy machinery has worked wonders. Returning from a three-month's visit to the Prairie Provinces, Thos. N. Havens, of Elgin County, Ont., related some of his experiences to the staff of "The Farmer's Advocate," and described in particular a thresher which to him appeared like a wonderfully efficient piece of machinery.

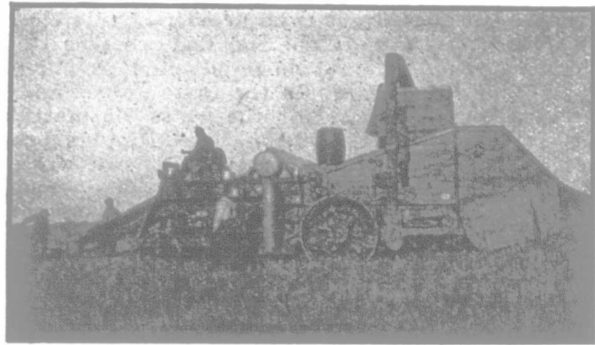

A Stook Thresher.

This stook thresher is used in the West by extensive grain growers.

The separator in question was propelled by a powerful gasoline engine, but it also carried another engine to operate the machinery. It was equipped with a 32-inch cylinder and was a self-feeder, the sheaves being thrown upon a table which projected out in front. One man sat at the wheel and directed the machine across the field, for it was used essentially for stook threshing. Four spike pitchers who worked in pairs were employed. One pair would knock down a stook and have it ready so when the table of the separator approached within ten feet, of them they could begin pitching on the sheaves. When done with their stook they would pass by the next stook where the other pair would be waiting and go on to the next one and have it ready. In this way the machine would often go the entire length of the field without stopping. On top was a large tank which held 50 bushels of grain, and when it filled it could be emptied through a pipe into a wagon used for conveying the grain to the elevator or storing place. Five men and a chore boy with a horse and wagon to supply fuel, water, or other requisites operated the thresher.

Mr. Havens commented on the difficulties experienced by farmers on small holdings in some localities to procure help. They had no money neither could they procure loans from the banks on their wheat even after it was threshed. In many cases their homesteads were mortgaged and they owed the Government for their seed grain. The banks or loan companies did not consider



A Good Crop of Wheat.

This field of 24 acres yielded 50 bushels per acre. It is a reclaimed field, for a few years ago it would not grow 30 bushels of oats per acre. A short rotation and thorough cultivation brought about the change. The field is owned by W. D. Sanders, Exeter, Ont.

them good security, but after they obtained their receipt checks showing the grain had been delivered to the elevator or dealer they could procure money.

When the war broke out, and later, it was stated that Germany was prepared for a six month's fight but it now appears that she was fairly ready for a war of a year and a half, but her zenith has been reached and it is now a matter of how long she can last. Will it be six months, a year, or a year and a half more? The Allies gain strength—the central powers weaken.

Insect Friends and Foes of Agriculture.

Every farmer is forced to come in contact with his insect foes and, therefore, knows something about them, but very few farmers know that there is a large number of insects that are not foes at all, but are friends. We shall, therefore, discuss these friends first.

INSECT FRIENDS.

The first class of friends we shall treat of is composed of those insects which aid agriculture by acting as pollinizers of plants. Almost everyone knows that before a plant can produce a fruit or seed some of the pollen must first be placed on the sticky tip of the pistil. This act fertilizes the plant and is called "pollination." In this work honey bees are the most important insect agents, but bumble bees and numerous other wild bees help greatly, as do also wasps, various kinds of flies, moths, butterflies and many other insects. Many of the lower kinds of plants, or plants with inconspicuous flowers are pollinated in other ways, for instance by the wind, but nearly all plants with conspicuous bloom require the aid of insects for proper and full fertilization. What would happen if we had none of this class of insect friends? We should not have more than one apple, or pear, or plum, or peach or any of our other much loved fruit to the one hundred or more we now enjoy. Moreover there would be practically no fields or tomatoes, pears or beans, or of several other crops that are so necessary to us as foods.

The second class of insect friends consist of those insects that supply us with food, either directly or indirectly, through serving as food for the fish and birds that we use as food. Many tons of honey are produced in every country by the honey bee. A large part of the food of our fresh-water fishes consists of the water insects that live about the shores of the lakes and rivers that these fish frequent. Even the larvae of the troublesome mosquito serves in this way a useful purpose. Both domesticated and wild fowl feed to a great extent upon insects, the latter especially during the nesting season. So without taking time to go more into details we see that many insects may be friends in this important matter of providing food for us.

A third manner in which insects may act as our friends is as scavengers. If all the dead animals and plants, including trees of course, were to lie undestroyed on the surface of the earth they would soon make an intolerable condition of affairs. But scarcely in the summer does an animal or plant die before there gather to it various insects that quickly hasten the process of decay. Some of the insects that feed on dead animals are carrion beetles, rove beetles, blow flies and flesh flies. Any one who has watched how quickly a dead horse or smaller animal becomes a seething mass of insect life will readily understand why it has been said that a blow-fly can destroy a dead ox as quickly as a lion.

In the case of trees we have all seen beautiful pine trees that have been cut down or fallen and allowed to lie for a year or two in the forest, and then, when examined, are found to be perforated in numerous places by borers.

These borers are merely the larvae of certain kinds of beetles, chiefly long-horned beetles. We feel disappointed at the injury to the tree, but in nature the insects while themselves feeding on the wood are at the same time serving a useful purpose, because these holes allow the more rapid and deep entrance of disease and so hasten greatly the rate of disintegration of the tree. We see, therefore, that insects help us greatly by removing dead animals and plants and thereby giving back to the earth the substances of which they are composed and at the same time making room for other animals and plants to take their place.

The fourth way in which insects serve as friends is by many useful kinds helping to control injurious kinds. One class of insects that helps in this way is known as parasites, and another as predaceous insects. The latter merely capture their victims and feed on them as a lion would capture and devour a smaller animal, but the former kind pass all their larval stage either in or attached to their victims, finally killing them. There are many kinds of parasitic insects such as Tachinid Flies and Ichneumons, some resembling very closely house-flies, others resembling wasps. The latter may be quite large and sometimes have a very long ovipositor or egg-laying apparatus, or they may be extremely small.

NOVEMBER
small in
the nak
attack
these.
ply all
of these
maturity
back of
body.
maggots
of a pa
it feeds
ready to
How
remembe
in the
this or
that the
that wa
only on
not be
this pes
causes a
There
I shall
beetles
the pre
hemisph
The larv
are just
are the
semble s
two win
seen fee
Their la
and are
color.
larvae a
in the c
their a
save ou
structive
single th
show th
The
what ta
that wer
foes wou
inhabita
that ins
trolling
great pa
and seve
We m
insect fo
There
year tak
ly from
discuss
attention
and ther
crops.
There
but of t
powers o
Scale an
most des
the Prov
here for
the south
insect, c
the same
powers o
single fe
offspring
these at
twigs, le
soon do
that bec
warmer
sprayed,
few year
killed.
made 'n
tent of
and the
the pres
parasites
are hope
few year
process
vania wh
meantime
against
telligent
fruit dis
scale. I
vided the
taken in
dition.
this pes
valuable
Those w
Jose Sca
letin No.
The C
themselv
and pear
to be w
and in
does a g

Friends and Foes of Agriculture.

er is forced to come in contact with and, therefore, knows something but very few farmers know that a large number of insects that are not our friends. We shall, therefore, first.

INSECT FRIENDS.

class of friends we shall treat of is those insects which aid agriculture as pollinizers of plants. Almost every fruit before a plant can produce a fruit of the pollen must first be placed on the tip of the pistil. This act is called "pollination." In the case of bees are the most important in this respect and numerous other insects, as do also wasps, various moths, butterflies and many other insects of the lower kinds of plants, or inconspicuous flowers are pollinated for instance by the wind, but near-by conspicuous bloom requires the aid of proper and full fertilization. It is a common mistake to suppose that if we had none of these insects we should not have more fruit, or pear, or plum, or peach or any such loved fruit to the one hundred percent. Moreover there would be no fields or tomatoes, pears or other crops that are so necessary to us.

class of insect friends consist of those that supply us with food, either directly, through serving as food for other insects that we use as food. Many are produced in every country by a large part of the food of our insects consists of the water insects on the shores of the lakes and rivers. Even the larvae of the mosquito serves in this way a useful food to domesticated and wild fowl feed upon insects, the latter especially the nesting season. So without going more into details we see that many are friends in this important class of food for us.

Another class in which insects may act as scavengers. If all the dead animals, including trees of course, were not decayed on the surface of the earth we should make an intolerable condition of the earth in the summer does an ant before there gather to it various insects which hasten the process of decay. Insects that feed on dead animals, such as flies, blow flies and many other who have watched how quickly a smaller animal becomes a part of insect life will readily understand what I mean. It has been said that a blow-fly can eat a ox as quickly as a lion.

of trees we have all seen beautiful have been cut down or fallen and for a year or two in the forest, if examined, are found to be permeated by borers. These borers are merely the larvae of certain kinds of beetles, chiefly long-horned beetles. We feel disappointed at the injury to the tree, but in nature the insects while themselves feeding on the wood are at the same time serving a useful purpose, because these holes allow the entrance of disease and so hasten greatly the rate of disintegration of the tree. We see, therefore, that insects help us greatly by removing dead animals and plants and thereby giving back to the earth the substances of which they are composed and at the same time making room for other animals and their place.

way in which insects serve as many useful kinds helping to control the insects. One class of insects that are known as parasites, and are very numerous. The latter merely feed on and devour a smaller animal, but pass all their larval stage either to their victims, finally killing them. There are many kinds of parasitic insects, such as the house-fly, some resembling house-flies, others resembling other insects, but they are all very long ovipositor or egg-laying and they may be extremely small, so

small in fact that one can scarcely see them with the naked eye. Some of these very small ones attack insect eggs, laying their own eggs in these. A single tiny egg is large enough to supply all the nourishment necessary to carry one of these little creatures through all its stages to maturity. Some parasites lay their eggs on the back of their hosts, but many lay them inside the body. A few species deposit not eggs but living maggots upon or near the victims. The larvae of a parasite does not, as a rule, kill the thing it feeds upon until it is itself full grown and ready to transform into an adult.

How useful parasites are can be seen when we remember the severe outbreak of the Army Worm in the summer of 1914. Towards the end of this outbreak, examination in the field showed that there was scarcely one of these caterpillars that was not parasitized. This year I have seen only one Army Worm. Now the parasites may not be the only cause of the disappearance of this pest but they are certainly one of the great causes and probably the chief one.

There are many useful predaceous insects, but I shall only mention two: namely, Ladybird beetles and Syrphus-fly larvae. Everyone knows the pretty little Ladybird beetles with their hemispherical shape and often brilliant colors. The larvae of these look like little alligators and are just as fond of destroying other insects as are the adults. Syrphus-fly adults usually resemble small bees or wasps but they have only two wings instead of four. They may often be seen feeding upon flowers or hovering above them. Their larvae are legless, taper towards one end and are stout and usually grayish or brown in color. The Ladybird beetles and the Syrphus-fly larvae are the two most helpful insects we have in the control of aphids or plant lice. Without their aid it would often be almost impossible to save our crops from these prolific and very destructive little pests. This is, however, only a single illustration of many that could be used to show the good predaceous insects do.

The more one studies insects and thinks over what takes place, the more inclined he is to feel that were it not for our insect friends our insect foes would make this earth almost or quite uninhabitable for man. I do not mean, however, that insects are the only forces at work in controlling our foes because disease also plays a great part, as do also extremes of heat and cold and several other things.

We must pass on now to consider briefly our insect foes.

INSECT FOES.

There is no doubt that injurious insects every year take a large toll from farmers and especially from fruitgrowers. As there is not time to discuss many of these insects, we shall devote our attention first to our worst two orchard insects, and then to a few of the chief pests of the field crops.

There are many insects that attack fruit trees, but of these, two stand out pre-eminent for their powers of destruction. These are the San Jose Scale and the Codling Moth. The former is the most destructive insect pest ever introduced into the Province, but fortunately, though it has been here for twenty years, it has not spread beyond the south-western counties. It is a very small insect, circular, and when full grown, has about the same diameter as the head of a pin. Its powers of reproduction are wonderful: from a single female there may be more than a million offspring by the end of the year. As all of these attach themselves to the trunk, branches, twigs, leaves or fruit and suck the juices, they soon do a great deal of harm. Any orchard that becomes infested with this pest in the warmer parts of the Province, and is not sprayed, is doomed to complete destruction in a few years, even the largest apple trees being killed. An exception to this statement should be made in the case of sour cherries and to some extent of Kieffer pears, the former being immune and the latter not often badly attacked. Up to the present time there have been only a few parasites attacking this scale in Ontario but we are hopeful that these will become abundant in a few years. We have endeavored to hasten the process by introducing parasites from Pennsylvania where they are doing much good. In the meantime there is a very satisfactory remedy against the insect and no man who uses it intelligently need lose a single tree or have his fruit discolored and rendered unsalable by the scale. Even the worst infested orchards, provided the trees are not too nearly dead, can be taken in hand and brought back into perfect condition. Fortunately the spraying necessary for this pest kills several others also and is very valuable against some diseases of fruit trees. Those who wish to study more about the San Jose Scale and how to fight it should read bulletin No. 219.

The Codling Moth does no injury to the trees themselves, but attacks the fruit of the apple and pear. It is the insect that causes the apple to be wormy. It is found all over the Province and in unsprayed or poorly sprayed orchards does a great deal of harm. In the warm part

of the Province where there is a larger percentage of a second brood the amount of injury to the fruit varies from 40 per cent. to 90 per cent. In the colder portions it is less and runs from about 10 per cent. to 50 per cent. (For life-history and means of control of Codling Moth read bulletin No. 187).

We can easily see, therefore, that the growing of clean apples is by no means an easy job. The fact is that insects and fungous diseases make it impossible to grow apples successfully on a commercial scale without spraying. It is, however, most gratifying to know that thorough spraying at the right time and with the right mixtures (see the Spray Calendar) not only completely controls these two insects but practically all other orchard insects and diseases; so that in an average year it is not uncommon to find orchards in any of the fruit districts where over 95 per cent. of the fruit is free from insect injuries or fungous diseases.

We shall not devote further attention to orchard insect pests but pass on to a brief discussion of the common insects of field crops.

The chief insects attacking such crops are grasshoppers, cutworms (including the army worm), wireworms and white grubs. These are familiar insects to almost every one. Each kind is capable of doing an enormous amount of injury, the amount depending partly upon the weather conditions. For grasshoppers we have at least in the so-called "Kansas Remedy" found a most satisfactory and cheap remedy so that no crop need be severely injured by these insects if the owner uses this treatment. (The remedy is described in the lower part of this year's Spray Calendar). The same remedy sometimes, however, with slight modifications, will usually prove quite satisfactory against cutworms and army worms.

It is interesting to know that attacks from grasshoppers, wireworms, white grubs and usually from cutworms too can be prevented by simply following the practices of good up-to-date farming in which a short rotation of crops with fall ploughing and thorough preparation of the soil before seeding play a very important part. This is a great source of encouragement to the man who is trying to do his best. A short rotation of crops means that there will be no old pasture fields on the farm. These are the pet breeding places of grasshoppers, wireworms and white grubs. It is a rare thing to find serious outbreaks of these pests on farms where no old pasture fields exist. Again a short rotation of crops means that the insects in any particular field are deprived of their special food and either have to starve or seek their food elsewhere, often falling to reach it; for instance, wireworms and white grubs attack grasses and such cereals as wheat, oats, and barley, but seldom do any injury to peas or clover; hence a short rotation of crops in which clover or peas play a part will help to starve them out. Good farming, moreover, means careful preparation of the soil for the seed and the selection of good, plump seed with the natural result that the plants will be more vigorous and thus better able to withstand the attacks of insects than weaker plants on poorly farmed land. An illustration of this is seen in the case of the Hessian fly. This insect delights in attacking unthrifty wheat plants. I have counted as many as 1,000 of the pupae in a single square yard in a poor field of wheat. It is not at all uncommon to see two fields close together, one scarcely at all injured by the Hessian Fly and the other severely injured, the chief reason for the difference being the better seed and condition of the soil in the former. I am not speaking now of the value of late sowing to prevent Hessian Fly attack, though this is often very helpful but may be overdone. My aim has been to show that the better a man farms, whether he knows anything about insects or not, the less injury will be done by these to his field crops.

It is impossible to go into this subject now in fuller detail, but in conclusion it may be well to say that we should never get into a panic about insects and fear that some day some new and terrible pest will come to our country that will do incredible damage. New pests are not arriving so frequently as most people think, and even if some do come there is very little fear that methods of controlling them will not be found. Most of the insects that are thought to be new have been here for years but have seldom been noticed because of the controlling influences mentioned in the early part of this address.—An address by Prof. L. Caesar and reported in the Canadian Entomologist.

Harper's Weekly in a biting cartoon discloses "The Patriotic Congressman" in the trenches, rifle in hand, for the safety of the great American pork barrel.

"Vorwärts," a widely-known Berlin paper, has been suppressed for asking why Germany was at war destroying its own people and drenching Europe with blood?

Alfalfa Cured Well on Tripods.

Editor "The Farmer's Advocate":

You will remember having published, (a few months ago), a description of curing alfalfa on a rustic tripod. The matter interested me, and having alfalfa to cure I decided to give the method suggested a trial. I have done so with very satisfactory results.

My alfalfa is not in an open field, but in the orchard, hence the light and air circulation were not at maximum. The first lot was cut just the day before nearly a week of wet weather. It lay on the ground for some five or six days when I feared it would spoil. I had moved it a few times and even put it in small bunches, but it continued wet. I got the tripods and laid about four hundred-weight (cured hay weight) on each. Fortunately we had two or three fine days with slight breezes. The hay dried and soon was curing well. I have taken it in at different times. Some is still on the tripods (Nov. 11), having been there over two months. It has had four heavy rains on it and yet retains a good alfalfa flavor. I find the leaves adhere to the plants well. The hay when cured comes off the tripod in flakes representing the forkfuls laid on. The stock eat it with evident relish.

On orchard farms such as this where feed is grown between the rows of trees I believe the tripod method is in every way the best one yet suggested. One handling of the hay is sufficient until it is wanted in the barn, and the leaf, which contains the essence of the plant, is preserved as it should be. I have genuine satisfaction in recommending others to try it next season.

B. C.

H. G. E.

THE DAIRY.

The Cream Can.

A writer signing herself "Farmer's Wife" in the Ohio Farmer recently gave an account of the value of the cream can, which is worth reproducing. Here it is:

The cream can is an important factor in many farm homes. No utensil has become popular more rapidly than it. It is the cream check that pays the grocer and dressmaker, builds houses and barns, buys the piano, sends the children to college and buys oil and gasoline. And what could do more than the cream can?

"Get another cow," was the slogan of the owner of the cream can; but the 1916 slogan is "Get a better cow." Then weigh your milk and use the Babcock tester. Scales are a necessity on every farm and the testing outfit is not expensive, neither is it so complex that it takes an educated person to use it as many suppose. With scales and Babcock test no one need keep cows, the cows will keep him. Don't guess; it pays to know. Weigh your cream—then if you ship 36 pounds when the check comes you will not be positive it was 38.

A man may pay 25 cents to guess on the number of beans in a can and consider himself a sport. But he is not in it with the man who loses from one to two per cent. to as high as 30 per cent. of the butterfat for the privilege of guessing twice a day on the speed of his separator. Why not buy a speed recorder, made especially to attach to any make of cream separator, and quit guessing? The common error is turning the separator too slow. The result of one or two turns per minute is the bowl running 600 to 700 revolutions too slow. This is losing money by turning the cream into skim-milk.

Besides timing to give the cream can a square deal, wash the separator every time it is used. If you do not do this, run some clean water through the separator after it has stood over night; then taste the water from the cream spout and you will know why it should be washed. The machine rusts after a time when not washed. Any one can afford to care properly for as high-priced a machine as the separator.

Have all cream the same temperature—as cold as possible when mixed. Keep the cream stirred as a smooth, velvety cream is more accurately sampled; hence, it gives a better test than the hard, lumpy cream. Cover cream with cheese cloth to avoid dust and insects and to give the cream air. Don't bring your cream in the kitchen to sour it, thinking you will get a better test for sweet cream tests the same as sour. The amount of butterfat in cream, is not affected by souring. Don't ship a thin cream, for you simply donate the skim-milk to the creamery, make transportation higher and besides a heavy cream keeps in better condition.

The owner of the cream can has endorsed and adopted a system by which the old-time burdens have been removed and the net results are greater than before. When you sell butterfat you are selling sunshine. When you sell grain you are selling the fertility of your farm. Can the farmer make a better investment than the cream can?

Improvement of Dairy Herds.

Several questions of interest to dairymen, and especially those who keep a record of their cows, are the following:

1. At what age are heifers desired to come into milk the first time?
2. In the rearing of heifers, what do you regard as the minimum production of milk and fat during the first milking period for each breed kept, that justified maintaining them in the breeding herd?
3. How long are heifers milked the first lactation period, and how long are they then allowed to go dry?

They were requested by the Agricultural Gazette from dairy officials of various provincial departments of agriculture, and we here give the replies from the Ontario Agricultural College, the Manitoba Agricultural College, Alberta Demonstration Farms and the Colony Farm, British Columbia, regarding these questions.

ONTARIO AGRICULTURAL COLLEGE.

By A. Leitch, Live Stock Investigator.

It has been the practice here for years past to have all dairy heifers drop their first calves at about two and a half years old, except in case of Jersey heifers. This breed as a rule drop their calves at about two years old, due to the fact that the Jersey heifer matures a little earlier than do those of the other dairy breeds. In the case of the few Shorthorns which have been placed in the dairy herd within the last two years, it has been the practice to have them calve at about three years of age.

"In the rearing of heifers what do you regard as the minimum production of fat during the first milking period for each breed kept that justifies maintaining her in the breeding herd?"

The following figures are subject to some adjustment depending on the conditions under which any certain animal milks throughout the year:

Breed	Lbs. milk	Lbs. fat
Holsteins	6,000	185
Ayrshires	4,500	170
Jerseys	3,750	170
Shorthorns	3,000	110

In the case of a heifer coming into milk very young a smaller minimum production would probably be advisable. In the case of a heifer having sickness or injury of any kind the minimum could be easily reduced, but as a general rule I should hesitate to retain any heifer which produced less in her first year than the requirement stated above, provided the heifer milked throughout the year without any injury or illness.

Provided heifers drop their first calves at about the age mentioned in the answer to question No. 1, we advise having them drop their second calf at about 12 months from that date; in which case they are milked to within two months or six weeks of their second calving. The habit of persistence in milking is fixed in a dairy animal in her first lactation period. Consequently it is wise to have her milk at least 10 months in that first period, even though the amount of milk given in the later part of this 10 months may not pay for the labor involved.

MANITOBA AGRICULTURAL COLLEGE.

By Jas. M. Brown, Lecturer in Animal Husbandry.

When one considers the period of years in which dairying as a specialized branch of farming has been practiced by civilized communities, it is rather surprising to find how little definite knowledge there is regarding certain phases of the breeding and selection of dairy stock.

The fact is that there is yet much experimental work to be done in order that the mass of conflicting opinions and beliefs may be narrowed down and the uninitiated have some reliable information to be guided by. It may be that some of the practices which we now follow will in the light of fuller knowledge give place to others and in the meantime we shall endeavor to profit by opinions based on experience.

The time-honored question as to the age at which heifers should begin their first lactation period permits of no definite answer. Such considerations as breed, method of feeding, nature of the soil and inherent capability for growth and development enter in to upset what may be established as a general rule, so that each animal presents to the breeder a separate problem in itself. There is a widespread belief that by breeding heifers at an early age the milking tendency becomes the better established.

It may be so; in the opinion of the writer there is not yet sufficient experimental evidence to prove that it is so, and, in the meantime, we find that the practice has in many cases led to harmful results, for breeders in their desire to establish the milking habit are prone to overlook the necessity of maintaining size and vigor, and what shall it profit one to obtain milking qualities in one generation if size and constitution be lost in the next? True, it is argued that if sufficient rest and liberal feeding are allowed between the first and second lactation periods, that the arrested development incident to early breeding

becomes then in its nature temporary. We have observed, however, that in many instances, it does not. In view of these considerations it has hitherto been and will continue to be the practice at the Manitoba Agricultural College to have heifers come into milk at the age of two years and six months, or two years and eight months. But, as stated below, there are always exceptional cases. From time to time there are heifers showing exceptional development for age, being strong of bone and horn, and which, if allowed to go until the age of two years and eight months before bearing the first calf, would be lacking in dairy qualities.

In the first lactation, heifers are milked fully as long as mature cows and this practice is maintained even when towards the end of the milking period the milk yield is so small as to warrant drying off in the case of a mature cow.

Heifers being mature at the first showing, no rest is given between lactation periods. Selection for milking qualities is constantly being made, but because of the comparatively recent establishment of the herd this selection is not yet quite as rigid as it is expected one day to be.

At the present time, however, in a milking period of eight months, Holstein heifers showing a yield of less than 5,000 pounds of milk, or Ayrshires and French-Canadians less than 4,500 pounds of milk, would not be retained in the herd.

ALBERTA.

By H. A. Craig, Deputy Minister of Agriculture.

Having four different breeds on our demonstration farms, we find that the principles that apply to the handling of one will not always apply to another. For instance, Shorthorn and Holstein herds seem to develop faster than the

We have had two-year-olds in milk only in 1914, and so far have an average of 10,360 pounds in milk and 376 pounds fat. They are going to improve on that this year.

Three-year-olds tested in R.O.P. work, average 15,102 pounds milk and 488 pounds fat, which we think will be improved on by 1,000 pounds milk and 40 pounds butterfat. The improvement over 1911 and 1912 has been over 3,000 pounds.

Mature cows in R.O.P. work average 16,879 pounds milk, 547 pounds fat, but this does not include several cows that have given over 20,000 pounds, but did not calve within the 15 months to secure certificates. The improvement in this class, over 1913 is 3,500 pounds. We are aiming to have our herd average, for two-year-olds, 12,000 pounds milk, 400 pounds fat; three-year-olds, 17,000 pounds and 525 pounds; mature cows, 20,000 pounds and 650 pounds.

The Slaughter of the Calves.

From time to time some exponent of more live-stock rises to remark against the slaughter of the calves and not always is this without reason. We must agree that very often calves which should be kept in the herd for breeding purposes are turned away for veal and their owner gets very little profit from them, and they are not permitted to do the good in the herd which they would have done if kept for breeding purposes. However, there are large numbers of calves raised each year which should go the veal route, and many of those which are killed while very young would be of no use if kept in the herd as breeders. The good dairyman has a basis upon which he works in selling or keeping his calves as the case may be. He uses, first of all,

a pure-bred sire with milking propensities well marked in the blood of his ancestors. He keeps in his herd nothing but the best individual animals and the heaviest milkers and he weighs the milk from each cow or heifer regularly and systematically, and, if necessary, has the milk tested for fat so he knows exactly what each of his cows is doing and whether or not calves from that cow are likely to go on and make valuable animals to place in his herd. If the cow, mother of the calf, cannot, through milk production, justify her existence in the herd there is little reason why the calf from such a mother should be kept past veal age, and it is far better that such a calf should go to the butcher early in life than to prove a bill of expense, in fact, a robber, in the dairy herd. There is little use of keeping an inferior

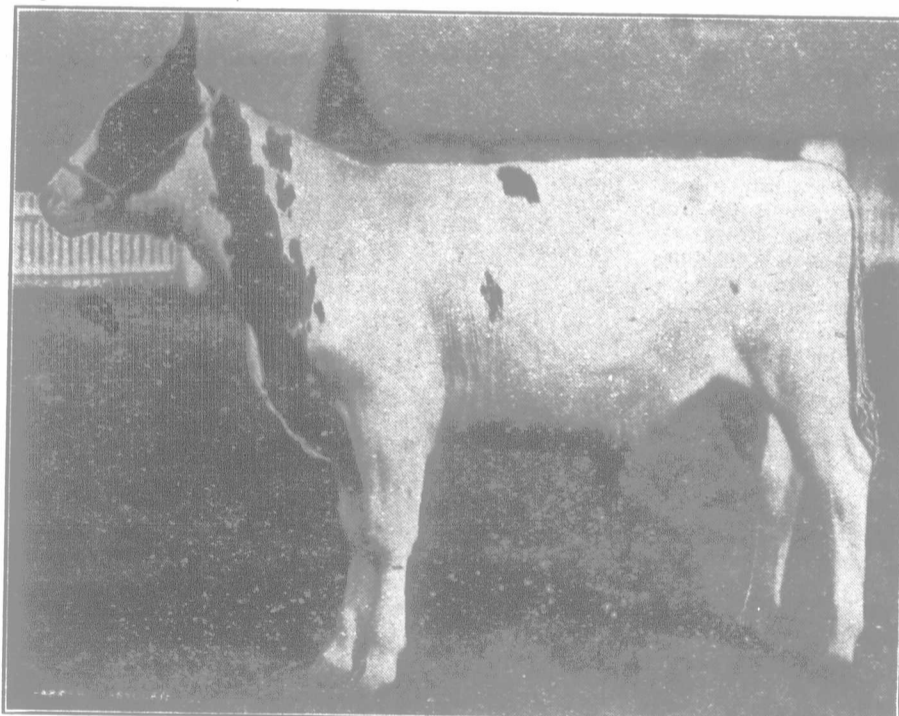

Burnside Invincible Masterpiece.

First-prize senior Ayrshire bull calf, and junior champion at Toronto, 1915, for R. R. Ness, Howick, Que.

Ayrshire and Jersey, consequently we have them freshen from two to two and a half years old. In order to secure some size in the other two breeds, we do not allow them to freshen until they are two and a half or three years old, depending somewhat upon the individual.

We aim to wean out all the four-year-old heifers that do not reach the following standard:

	Lbs. milk in one year
Shorthorns	4,500
Jerseys	7,500
Ayrshires	8,000
Holsteins	10,000

We have not yet set any standard for fat production, but intend to discard those that do not produce milk testing at least 3.2 per cent.

As far as possible, our herds are milked about 11 months during their first lactation period and allowed to go dry at least six weeks before they freshen again. Our herds have not been established sufficiently long enough to show any marked improvement in the average production.

COLONY FARM, BRITISH COLUMBIA.

By C. W. Holmes, Herdsman.

Taking the questions consecutively as set down, the answers, referring to our herd, are:

1. We find that heifers calving at the age of 27 months do the best.
2. The amount of milk and fat for a two-year-old heifer, to be retained in this herd is 10,000 pounds milk and 3,300 pounds fat. Holstein-Friesian is the only breed kept.
3. We like them to milk at least 12 months, then let them go dry for 10 weeks.

dairy calf to the age of two or three years, because it will generally cost more especially when grain is high in price, as it is now, to put meat on this wedge-shaped dairy carcass than it is worth. It would be folly then to keep all calves without discrimination. Only the best should survive for breeding purposes, and the only man who knows which are the best is the man who is using a proper sire of a heavy milking strain and is weighing the milk regularly from the cows to which this sire is bred, and keeping the calves from those cows which lead in milk production and give enough to pay for all feed and labor and leave a handsome profit besides. The point is, to be able to pick out calves which should remain in the herd, something must be known about the producing ability of their dams and this cannot be estimated by the ordinary guess-work method. The scales and the tester should be made just as important in determining the future individuals which shall comprise the herd as in determining which cow now milking shall remain in the herd.

It is important also that no faulty individuals as to conformation and type be kept in the herd. It is not enough that the sire be from good milking ancestry and the cow be a heavy milker herself. They must have such conformation and propensities that the calves show the desirable type of the milking breeds. Faulty calves should be discarded even though their ancestry be right. This close selection will send thousands of calves to the block as veal which would otherwise be kept in the herd at a loss. It may be, after all, that there are not too many calves slaughtered young, but that there is not enough system followed in determining which shall go and which

NOVEMBER
shall
which s
go whic
hands o
all his
by proc

Why
The
know v
milking
and tes
much m
he tell
calves f
Cow
but mor
Weight
weights
good, so
ers as w
The l
ing is m
from mo
With
man is a
proporti
The fi
Mills, Q
cows in
was \$29
calved \$
and got
At Ma
has incre
in 1909
an incre
98 per ce
in Ha
menced c
ten cows
pounds o
7,436 po
increase
of fat in
At a
patrons v
They wer
Last year
A Que
\$400 fro
\$800 fro
weed out
It cert
doing.
Get rid o
ones, and
large-pro
be a larg
Circular

Editor
I have
on poultr
issues of
the articl
"Selecting
given by
several of
Since cl
a little cl
that appe
selecting
watching
has almost
hen moult
November
feathers, s
a profitabl
my laying
tention to
my pen fo
which look
feathers e
out the s
hen is a fa
and even
year, so t
pearance is
ance is wh
It is im
nest his h
for them,
the layers
for egg pr
his hens a
have found
is late to
pretty goo
in preferen
the middle
most of t
matter for

ad two-year-olds in milk only in far have an average of 10,360 and 376 pounds fat. They are on that this year.

olds tested in R.O.P. work, average milk and 488 pounds fat, which be improved on by 1,000 pounds butterfat. The improvement 1912 has been over 3,000 pounds in R.O.P. work average 16,879 47 pounds fat, but this does not cows that have given over 20,000 d not calve within the 15 months icates. The improvement in this 3 is 3,500 pounds. We are aiming herd average, for two-year-olds, milk, 400 pounds fat; three-year-olds and 525 pounds; mature pounds and 650 pounds.

ughter of the Calves.

to time some exponent of more to remark against the slaughter and not always is this without re- agree that very often calves are kept in the herd for breeding turned away for veal and their little profit from them, and they do to do the good in the herd old have done if kept for breeding. ever, there are large numbers of ch year which should go the veal y of those which are killed while ld be of no use if kept in the herd e good dairyman has a basis works in selling or keeping his se may be. He uses, first of all, a pure-bred sire with milking propensities well marked in the blood of his ancestors. He keeps in his herd nothing but the best individual animals and the heaviest milkers and he weighs the milk from each cow or heifer regularly and systematically, and, if necessary, has the milk tested for fat so he knows exactly what each of his cows is doing and whether or not calves from that cow are likely to go on and make valuable animals to place in his herd. If the cow, mother of the calf, cannot, through milk production, justify her existence in the herd there is little reason why the calf from such a mother should be kept past veal age, and it is far better that such a calf should go to the butcher early in life than to prove a bill of expense, in fact, a robber, in the dairy herd. There is little use of keeping an inferior to the age of two or because it will generally cially when grain is high in ow, to put meat on this wedge- cness than it is worth. It would keep all calves without discrimina- best should survive for breeding e only man who knows which the man who is using a pro- milking strain and is weighing y from the cows to which this keeping the calves from those d in milk production and give r all feed and la' or and leave a esides. The joint is, to be able s which should remain in the must be known about the pro- their dams and this cannot be e ordinary guess-work method. e tester should be made just as rmining the future individuals- prise the herd as in determin- ow milking shall remain in the

also that no faulty individuals n and type be kept in the herd. hat the sire be from good milk- the cow be a heavy milker her- have such conformation and the calves show the de- frable g breeds. Faulty calves should though their ancestry be right. n will send thousands of calves veal which would otherwise be t a loss. It may be, after all, t too many calves slaughtered here is not enough system fol- ing which shall go and which

shall be kept. Undoubtedly, many are kept which should go and equally true is it that many go which should be kept. The matter is in the hands of the dairyman, and the sooner he makes all his selections on conformation and type backed by production will it be righted.

Why Should Dairymen Keep Milk Records?

The basis of building up a dairy herd is to know what each cow is producing through the milking period. No one can tell how much milk and fat a cow produces unless the milk is weighed and tested. If the owner does not know how much milk and fat each cow produces, how can he tell which are the best cows to raise heifer calves from?

Cow testing not only produces better cows, but more interested and better dairymen.

Weighing, sampling, and marking down the weights of each cow's milk at regular intervals is good, sound business and keeps tab on the milkers as well as on the cows.

The best results are secured when record-keeping is made a permanent practice and continued from month to month and from year to year.

With each cow's record before him, the dairyman is able to feed more intelligently. "Meal in proportion to milk" is a good motto.

The figures of a creamery statement at Way's Mills, Que., show that from a herd of twelve cows in 1912, the cash received by the owner was \$297.85. In 1914, from twelve cows he received \$804.48. He discovered the poor cows and got rid of them.

At Mallorytown, Ont., a herd of twelve cows has increased from 3,726 pounds of milk per cow in 1909 to 7,388 pounds per cow in 1914; this is an increase of 2,662 pounds of milk per cow, or 98 per cent.

In Hastings County, Ontario, a farmer commenced cow testing in 1912 and found his herd of ten cows averaged 5,780 pounds of milk and 187 pounds of fat. In 1914 his ten cows averaged 7,436 pounds of milk and 254 pounds of fat, an increase of 1,656 pounds of milk and 67 pounds of fat in two years.

At a Nova Scotia creamery there are thirty patrons who took up cow testing five years ago. They were then receiving only about \$30 per cow. Last year their cows averaged almost \$60 each.

A Quebec creamery patron in 1912 received \$400 from 15 cows. In 1914 he received \$800 from eleven cows. It paid him well to weed out the poor cows.

It certainly pays to know what each cow is doing. Keeping individual records will tell this. Get rid of the poor cows, carefully feed the good ones, and breed them to a pure-bred sire from large-producing ancestry, the result will certainly be a large-producing and profitable dairy herd.—Circular 16, Dairy Division.

POULTRY.

The Hen that Lays.

Editor "The Farmer's Advocate":

I have been much interested in the discussions on poultry keeping which have appeared in recent issues of "The Farmer's Advocate," particularly the article in the issue of October 14, entitled "Selecting the layers" and also the egg record given by "Wyandotte" and the replies from several of your readers.

Since reading these articles I have been paying a little closer attention to my own flock and find that appearances count for a good deal in the selecting of layers. I may say that I have been watching this for the past year or two and it has almost invariably been the case that when a hen moulted early, and in late October and early November looked clean and smooth in her new feathers, she was neither a good winter layer nor a profitable producer. Too often have I selected my laying stock in the fall, paying too much attention to the appearance of the bird and filling my pen for winter egg production with those hens which looked best by reason of having their new feathers early and not laying very much throughout the season. The roughest looking year-old hen is a fairly good proposition as a winter layer and even an egg producer throughout the coming year, so that this is one case where good appearance is deceiving, and where a rough appearance is what the poultrymen should go by.

It is impossible for the average farmer to trap-nest his hens and so have individual egg records for them, by which he can operate in selecting the layers for another season or a breeding flock for egg production. He must get familiar with his hens and pay attention to their actions. I have found, from experience, that the hen which is late to roost and early to rise is generally a pretty good layer, and one which should be kept in preference to the hen which is on the roost in the middle of the afternoon and is moving there most of the next forenoon. It is not a hard matter for the busy farmer at this season of the

year to pay enough attention to the hens to see which are last to go to roost, and it is an important point in selecting layers.

Another thing which I have noticed with my flock is that the hen that is the big eater is also the big layer. As is the case with the dairy cow, you cannot get the finished product without a large consumption of feed. The most profitable dairy cow is the one that will eat readily large quantities of feed and the same is true of the hen. The hen that mopes off when feed is thrown to the flock, as a general thing, is a non-producer or one which will not pay her way and is living at the expense of the better layers in the flock; but the hen that is on the job as soon as the feed pail appears and stays with the feed, scratching until the last kernel is found, will usually be found a regular and heavy layer.

I have been looking over my flock and find that, according to the article published in your issue of October 14, those hens which have moulted late also have the bleached-out appearance of legs and beak and I believe that this is a very good sign of what they have done in the way of egg production during the past season. Those which have had the color used up from their beaks and legs must have been heavy layers and must have placed this color in eggs. At any rate I am selecting on this basis.

I also believe that it is well when selecting hens at this season of the year to keep the heavy hens. I do not mean by this that those hens which are over-fat should be retained, but the big, solid, weighty hen is generally the producer rather than the fluffly individual which is light. It is the weighty hen which eats best, and as before stated the hen must eat to be a producer.

I always like to see the hens busy and believe that in selecting hens in the fall and even in the selection of pullets it is a wise precaution to discard any that are not, the greater part of the day, busy scratching for feed or working in the dust bath or at some such exercise. The busy hen is the laying hen.

Another point which I might mention is that in all selection work it is well to take into consideration the constitution of the bird. It will not pay to winter in the laying pen, pullets or year-old hens which have long heads, long, thin beaks and sunken eyes. Just the other day one of my pullets of such conformation sickened and died, and apart from the value she would have had as a table bird I believe she is much more profitable dead than she would have been if she had lived and had been wintered. Select only the birds showing wide heads, short, thick beaks and full eyes, which denote vigor.

It is also well to pay attention to the body conformation of the bird. Many pullets, particularly those from in-bred strains or from defective ancestry will show crooked backs and crooked breast bones. All these should be discarded as these defects are hereditary, and the hens showing them rarely exhibit laying propensities so well marked as those of well-formed birds.

Middlesex Co., Ont.

T. W.

Maturing Chicks.

Editor "The Farmer's Advocate":

Apropos the discussion which has been going on in your poultry columns during recent weeks, I might say that I have noticed during the past season that early-hatched pullets made much more rapid growth and were larger at four months of age than were later-hatched pullets at the same age. I had in my flock a brood of chickens hatched by a hen on the 10th day of April and these grew and matured much more quickly than did a larger lot of chickens, also hen-hatched, which came out the 18th and 20th of May. All these chickens were fed practically the same and all were hatched from eggs from the same breeding pen, so that there should have been no difference in vitality, and if there had been it should have been in favor of the late-hatched birds, as it is generally conceded that vitality increases in the spring with the warm weather. Next year I plan to hatch all my chickens early, but I was wondering whether any of your readers could explain why these early-hatched birds should have done better than the later-hatched chicks. Of course, there may be something in the season which was nice at first and later became very wet. The early birds got a good start before the wet spell commenced; the later birds suffered a good deal from this cause.

I also noticed this summer a very marked difference in the growth and early maturity of birds given free range as compared with those kept in a small wire enclosure, but with fair-sized run. The birds referred to and which were hatched the 18th and 20th of May did not make anything like so rapid a growth as some hatched from eggs from the same breeding pen about two weeks later and given free range over a large farm. I was privileged to see these birds a short time ago on the farm and they were easily half as large again as my birds hatched the 20th of May two weeks earlier and not yet mature. It seems to me that one of the most important factors to success with poultry culture is as much free

range as possible, and the farmer is in the best position to give this. The colony-house system, where the chicks are moved to the corn field or to the stubble field after the grain is taken off, seems to work out very satisfactorily indeed and should be followed out by more farmers.

Ontario Co., Ont.

"FEATHERS."

Unjust Treatment.

Editor "The Farmer's Advocate":

In looking over the advertisements in your issue of Oct. 28 I noticed one advertisement which appeared almost the same and by the same firm, in a Montreal paper. Last fall I answered the advertisement for strictly fresh eggs, preferably from farmers keeping 100 hens or over, and was assured that I would be paid the very highest price with prompt remittance. I sent this man two cases of eggs within four days of each other when our Egg Circle was paying 40 cents per dozen for strictly fresh eggs, and received promptly returns for two full cases the first at 35 cents per dozen, the second at 34 cents per dozen. I wrote the dealer at once that these prices were not satisfactory, as I could get as much at the village grocery, the proprietor of which also shipped to Montreal, and that unless he could cash up some more money no more eggs would be sent him. He sent me a very insolent letter to the effect that he should not have made returns for five or six weeks, and then I would not have known what I was getting for my eggs. I told him that I was not in the habit of dealing with any such people and for him to please return my two cases. This he did not do, so I wrote to the Police Department and they sent a man around to enquire why they were not returned. He acknowledged having the cases but said that one case lacked three dozen of being filled and he was holding cases to cover shortage. This, the Police Department wrote me and I sent them his letters and returns, but they refused to have anything further to do, saying it was not a case for their Department. Then, sooner than let this thing drop I wrote to the Department of Trade and Commerce and they informed me that I had followed the usual trade practices in the matter and that I would have to enter a suit under one of three different charges against this man in order to get my two egg cases.

Well, I thought perhaps I had gone far enough for a woman in so small a matter, but I do not intend to hold my tongue and allow someone else to be bitten. He is not advertising as yet in the Montreal paper so I am led to believe he is not expecting many fresh eggs from the same people who dealt with him last year.

Why could not some of you farm paper people invite your correspondents and readers to furnish you with the names of dealers whom they are assured by experiment are not honest, and when you had made a list of them furnish the same to people asking for information for a small fee? It would save many people from losing money, time and temper in the same way that I have done.

Leeds Co., Ont.

MRS. W. H. WARREN.

[Note.—Will readers kindly give us a list of names and addresses of dealers and commission men in their own districts or in their nearest large centers with whom they have had dealings and have found them straightforward and doing business satisfactory to the seller of produce. Also we would appreciate a list of the names and addresses of the other class of commission men or dealers who have been unfair to the producer, and we hope and trust this latter list will be small. We only want to hear from those who are satisfied and those who have good reason for dissatisfaction.—Editor.]

A Great Record.

Records for hens are becoming as important as records for cows. Read this little account of the latest world beater.

With a record of 314 eggs in 365 days, Lady Eglantine, a White Leghorn pullet, became today the champion egg layer of the world.

The little hen, which weighs three and a half pounds, completed her year of an egg-laying competition at Delaware College, Newark, Del., and beat the previous record of 286 eggs by 28. The pen of five hens of which she was a member also broke the American pen record with 1,211 eggs. The average barnyard fowl produces only 70 eggs in a year.

For selling eggs decayed and unfit for use an Ottawa butcher and egg dealer was fined \$10 and costs. As usual, he blamed it on the farmer whom he claimed sold them as "strictly fresh laid." The police magistrate reminded him that that excuse "would not go" as he should find out for himself whether the eggs were good or not before offering them for sale.

HORTICULTURE.

Some Greenhouse Problems.

Many new greenhouses are erected each year and consequently growers new at the work of forcing plants under glass annually launch out upon a new enterprise. In the greenhouse, culture is to a large extent artificial for it removes the operation largely from nature's care and the operator looks after the moisture, ventilation, and other features contributing to plant growth. C. W. Waid, of Lansing, Mich., recited some of the problems a beginner might encounter to the Vegetable Growers' Association recently held in Toronto. Following in this article are some thoughts gleaned from his address:

During the first year everything is new, the soil to a certain extent is healthy or in other words it does not contain micro-organisms which develop under glass and cause serious trouble. On account of this a beginner may experience signal success during the first year, but afterwards he must pay no small amount of attention to every detail in order to avoid pests and fungous diseases that often wipe out whole crops. To the man who is considering building a house Mr. Waid threw out the following points: The closer he can get to a good market the better; avoid having to ship if possible; locate the houses near a shipping point if coal is to be used as fuel; it is expensive to move large quantities of coal even a few miles, especially over poor roads; the soil over which the houses are to be built should be well drained; a heavy clay is last desirable; a sandy loam is to be preferred although a clay loam is quite satisfactory; be sure of an abundance of pure water supply; if possible locate the houses where they will be protected from the prevailing winds.

The condition of the greenhouse soil spells success or failure for the grower. It must be open and porous or in other words full of humus or organic matter. Stable manure is a prime requisite in greenhouse work, but in some cases it lacks sufficient quantities of phosphoric acid. This may be supplied by adding about forty pounds of acid phosphate to each ton of manure.

The speaker considered the summer mulch used at the institution at Lansing, as quite satisfactory. From four to six inches of manure is applied on the surface of the greenhouse soil as soon as the cucumber and tomato crops are taken out in August. This manure is left on the surface for from four to six weeks, during which time it is soaked with water once or twice a day. This watering keeps the soil in good mechanical condition and carries down into it much of the available plant food. Just before the next crop is to be planted the coarser part of the manure is removed and the remainder spaded into or under the soil.

Most of the problems arise out of poor seed, poor plants, lack of ventilation, improper watering and presence of diseases. The latter to some extent depend upon the way in which the house is operated. To avoid diseases the grower must be constantly on the job and pay strict attention to details.

Guard Trees Against Vermin and Sunscald.

A plantation of young fruit trees is every winter exposed to three dangers, namely, rabbits, mice and sunscald. Winters may pass by without any injury resulting from these quarters, yet one never knows when the injury is likely to be most severe and it is wise to take precautions during the first few years the trees are set out.

Under a system of clean cultivation there is not the same danger from mice. Coarser weeds harbor them and increase the dangers of girdling. In peach orchards we have seen young and tender twigs cut from the branches and allowed to remain on the ground. These the mice and rabbits will devour leaving the trees untouched. However, this is not an altogether trustworthy means of evading trouble. If the weeds and rubbish are cleaned away from the tree in the fall and the snow is kept packed firmly around the trunks conditions are not suitable for the mice and considerable injury may be avoided. Unless some protection is provided for the trees, fruitgrowers with young plantations should at least tramp the snow around the trunks to fortify them as much as possible. A mound of earth from eight to twelve inches high packed closely up to the small trunk will often deter the mice when they are burrowing through under the snow. However, there is no hindrance so good as a protection of veneer or building paper. Tar paper has been known to cause injury to the tree. Plain building paper is preferable. Wrap this around the tree, not too tightly, but be sure that it connects closely with the ground. Around the bottom pack a little soil and it is doubtful if the mice will cause any harm. Newspapers or a have been used with considerable success. When applying them start with one corner and lay each day, that the paper will wrap the

tree well down to the ground. After the rolling is done the operator will finish with the opposite corner. This does not allow the wind as much opportunity to get under the edges and tear the paper off. Tie in three places with binder twine. If this method is followed carefully the wind will not likely remove many papers during the winter.

Veneer can be purchased at basket factories at a reasonable figure. In some cases it will require two lengths of this to reach to the branches, but there is usually an air space between the veneer and the trunk of the tree which seems to make the temperature more uniform during sudden changes of weather and thus prevents sunscald, which is a serious trouble in some of the more northerly sections.

Paints have some value as protective agents. Mixed paints are advised against for this use. They might contain some destructive agents which a mixture of white lead and pure linseed oil will not. The latter mixture is advisable. Peaches and cherries are excepted, however, for some injury from paint on these trees has been known to occur.

FARM BULLETIN.

The Bugle.

The Empire needs, in this dark hour of slaughter,
Great-hearted men, unawed by doom or dread.
What valour hast thou shown what service
brought her

To match the tribute of her glorious dead?

Thou who the loyal standard boldly flaunted
While peace around thee guarded like a wall,
What dost thou now when Freedom is blood-
haunted?

Do braggart words but make thy deeds seem
small?

When in the future days they tell the story
Of how the brave, the hero-hearted died,
When Liberty is crowned with fadless glory,
Will you be standing honored at her side?

Because you ventured all, nor sought a reason
Why other men should die and you go free,
Because you held not back in coward land
While comrades fought your fight on land and
sea?

Amid the gallant ranks that did not waver

Before the blight that shook old Britain's shore,
Will you be one whose prowess helped to save
her?

Who went to war that war should be no more?

The troop-ship in the harbor waiteth ready,
The tumult thickens. Hear the scornful word!
The foe is mocking! Lift the anchor, steady!
High tide. The ship's away. Are you aboard?
ALBERT D. WATSON.

Current Notes.

By Peter McArthur.

About thirty years ago an enterprising publisher who probably lived before his time issued a set of volumes under the title "Picturesque Canada." I do not remember having seen a set of the books but I have a distinct recollection of the fact that they were unloaded on the farmers of the country by some selling scheme that provoked a lot of wrath. "Picture-res-kwee Canada," with the accent on the "kwee," came in for a lot of abuse from people who claimed to have been taken in by sharp agents, and there was so much anger about the way the people were induced to buy the books that I doubt if many of them were ever read. At the present time there is need of a comprehensive book or set of books that will let each province know how the other provinces live. The new spirit of nationality that is stirring in the country owing to the unity of purpose caused by the war makes it imperative that Canada should overcome all sectionalism and that the people of every part of the country should have a sympathetic knowledge of the needs and aspirations of all other parts. If "Picturesque Canada" were published to-day and made thoroughly up-to-date it would be a valuable contribution to the life of the country. While all the provinces have the same end in view, the building up of a united Canada, they are so vast in extent and so widely scattered that few of us know much about any province except our own and we do not know any too much about that. From time to time I get a copy of some paper published in another province and it seems as if it were from another country. The folders issued by our transcontinental railroads come nearer than anything else to giving us an idea of the diversity of Canadian life, but as they are issued for special advertising purposes they lack scope. There is a great field for the editor or publisher who will undertake the work of introducing the people of Canada to one another.

At a patriotic meeting which I attended last night a number of returned soldiers told something of their experience in battle. They were all men who had been wounded and disabled for further service, and as I looked at them I felt that their wounds were more eloquent than their words. They were all young men in their early twenties and now they must undertake the long battle of life with crippled bodies and some with partially blinded sight. Compared with the sacrifices they have made the greatest sacrifices possible in the way of aid to patriotic and Red Cross funds and similar causes are merely trifles. And back of the wounded are the dead whose dependants face poverty. No matter what taxes the war may bring it is still our duty to give, and with all our giving we shall give nothing as compared with those who have offered their lives.

I know it was wrong and perhaps I shouldn't talk about it, but the other day I came near giving an exhibition of sinful wrath. While riding in train and placidly reading a newspaper I could hear a man carrying on a conversation in booming tones a few seats away, I was too far away to hear what he was saying to the attentive listeners who occupied the double seat with him, but by the sound and look of him it was quite evident that he considered himself somebody in particular. He was apparently quite accustomed to public notice and was not averse to getting it whenever possible. Then the conductor was passing I asked him who the eminent person was and he whispered the name of a politician of some note. My curiosity was satisfied, and I returned to the task of trying to get at the significance of the latest war surmises in the paper. I could still hear the organ tones of the near great man and might have gone to sleep soothed by their music had he not lifted his voice and said with slow emphasis as if he wished everyone in the car to hear plainly—"I would pass a law—" Just then I saw red. I did not hear what he wanted to pass a law about. The fact that the wind-bag wanted to pass a law about something or other and possibly might have influence enough to do it was enough to make me boil over. I wanted to get up and shake my fist under his nose and talk some red anarchy to him for a few minutes. To make laws for other people seems to be the ambition of everybody from the Kaiser to the grocery store loafer. I have even had "moments of weakness" when I wanted to have some laws passed myself, but in my lucid intervals I know that our chief trouble is too many laws about all sorts of things. All special privileges are based on laws that someone has passed and what we need is an orgy of repealing laws. Of course I didn't shake my fist at him or do anything satisfying for I have a sore shoulder and might not be able to take care of myself properly in the argument that might have followed. But I certainly was stirred up. More laws! Wah!

Crop Yields in Ontario, 1915.

The following statements, furnished by the Ontario Department of Agriculture, give the area and yields of the principal field crops of Ontario for 1915. The areas have been compiled from individual returns of farmers, and the yield by a special staff in each township in addition to regular crop correspondents.

Fall Wheat.—811,158 acres yielded 24,737,011 bushels, or 30.5 per acre, as compared with 14,333,548 and 20.9 in 1914. The annual average per acre for 34 years was 21.3.

Spring Wheat.—162,142 acres yielded 3,439,949 bushels, or 21.2 per acre as compared with 2,169,425 and 18.3 in 1914. Average 16.1.

Barley.—552,318 acres yielded 19,898,129 bushels, or 36.0 per acre as compared with 18,096,754 and 31.2 in 1914. Average 28.1.

Oats.—2,871,755 acres yielded 120,217,952 bushels, or 41.9 per acre as compared with 108,564,322 and 37.3 in 1914. Average 35.9.

Rye.—173,736 acres yielded 3,210,512 bushels, or 18.5 per acre as compared with 2,315,582 and 16.7 in 1914. Average 16.5.

Buckwheat.—193,497 acres yielded 4,273,866 bushels, or 22.1 per acre as compared with 4,251,421 and 24.0 in 1914. Average 20.7.

Peas.—126,943 acres yielded 2,043,049 bushels, or 16.1 per acre as compared with 2,609,535 and 14.7 in 1914. Average 19.1.

Beans.—62,863 acres yielded 832,819 bushels, or 14.0 per acre as compared with 835,595 and 16.3 in 1914. Average 17.0.

Mixed Grains.—475,738 acres yielded 19,461,609 bushels, or 40.9 per acre as compared with 16,854,550 and 36.9 in 1914. Average 35.3.

Potatoes.—173,934 acres yielded 13,267,023 bushels or 76. per acre as compared with 26,717,557 and 159 in 1914. Average 116.

Mangels.—50,799 acres yielded 25,302,323 bushels, or 498 per acre as compared with 25,439,520 and 502 in 1914. Average 459.

Carrots.—2,439 acres yielded 636,232 bushels, or 281 per acre as compared with 767,070 and 313 in 1914. Average 342.

Sugar Beets.—22,890 acres yielded 8,556,281

otic meeting which I attended last
er of returned soldiers told some-
experience in battle. They were all
been wounded and disabled for
ce, and as I looked at them I felt
unds were more eloquent than their
were all young men in their early
now they must undertake the long
with crippled bodies and some with
ided sight. Compared with the
have made the greatest sacrifices
e way of aid to patriotic and Red
nd similar causes are merely trifles.
he wounded are the dead whose de-
poverty. No matter what taxes
bring it is still our duty to give,
ur giving we shall give nothing as
those who have offered their lives.

was wrong and perhaps I shouldn't
but the other day I came near giv-
tion of sinful wrath. While riding
placidly reading a newspaper I
man carrying on a conversation in
a few seats away, I was too far
what he was saying to the atten-
who occupied the double seat with
e sound and look of him it was
that he considered himself somebody
He was apparently quite accus-
ic notice and was not aware of
never possible. Then the conduc-
ing I asked him who the eminent
nd he whispered the name of a
ame note. My curiosity was satis-
fied to the task of trying to get
ence of the latest war surmises, in
could still hear the organ tones of
man and might have gone to sleep
r music had he not lifted his voice
a slow emphasis as if he wished
e car to hear plainly—"I would
Just then I saw red. I did
wanted to pass a law about
e wind-bag wanted to pass a law
or other and possibly might
enough to do it was enough to
ver. I wanted to get up and
nder his nose and talk some red
for a few minutes. To make laws
le seems to be the ambition of
the Kaiser to the grocery store
even had "moments of weakness".
to have some laws passed myself,
d intervals I know that our chief
many laws about all sorts of
cial privileges are based on laws
as passed and what we need is an
g laws. Of course I didn't shake
or do anything satisfying for I
ulder and might not be able to
myself properly in the argument
e followed. But I certainly was
ore laws! Wah!

Fields In Ontario, 1915.

statements, furnished by the Ont-
nt of Agriculture, give the area
e principal field crops of Ontario
areas have been compiled from in-
of farmers, and the yield by a
each township in addition to
respondents.

811,158 acres yielded 24,737,011
per acre, as compared with 14-
9 in 1914. The annual average
years was 21.3.

162,142 acres yielded 3,439-
21.2 per acre as compared with
8.3 in 1914. Average 16.1.

8 acres yielded 19,893,129
per acre as compared with 18-
2 in 1914. Average 28.1.

55 acres yielded 120,217,952
per acre as compared with 103-
3 in 1914. Average 35.9.

acres yielded 3,210,512 bushels,
as compared with 2,315,582 and
average, 16.5.

93,497 acres yielded 4,273,866
per acre as compared with 4-
0 in 1914. Average, 20.7.

3 acres yielded 2,043,049 bushels,
as compared with 2,609,535 and
average, 19.1.

3 acres yielded 832,819 bushels,
as compared with 835,995 and
average, 17.0.

475,738 acres yielded 19,461-
40.9 per acre as compared with
36.9 in 1914. Average, 35.3.

934 acres yielded 13,267,023
per acre as compared with 26,717-
1914. Average, 116.

99 acres yielded 25,302,323
per acre as compared with 25-
in 1914. Average, 459.

9 acres yielded 636,232 bushels,
as compared with 767,070 and
average, 342.

22,890 acres yielded 8,556,281

bushels, or 374 per acre as compared with 7,466-
819 and 403 in 1914. Average, 388.

Turnips.—97,451 acres yielded 46,598,851
bushels, or 478 per acre as compared with 46-
386,708 and 486 in 1914. Average, 433.

Corn for Husking.—309,773 acres yielded 21-
760,496 bushels, (in the ear), or 70.2 per acre,
as compared with 23,232,360 and 80 in 1914.
Average, 71.8.

Corn for Silo.—443,736 acres yielded 4,874-
377 tons (green) or 10.98 per acre as compared
with 4,751,223 and 11.36 in 1914. Average,
11.27.

Hay and Clover (including Alfalfa).—3,231,752
acres yielded 4,253,763 tons or 1.32 per acre as
compared with 3,842,544 and 1.13 in 1914.
Average, 1.43.

Mr. Bailey On School Fairs.

At the invitation of the Washington Depart-
ment of Agriculture, C. F. Bailey, Assistant
Deputy Minister of Agriculture for Ontario, at-
tended the annual gathering of State Leaders
in County Agent work in the States of the Union
across the line and delivered an address on the
subject of "The School Fair as a Feature of Dis-
trict Representative Work." The visit was the
outcome of a visit to Ontario a few weeks ago
of a Representative of the Washington Department
of Agriculture, who was much impressed with the
work as it is being carried on in Ontario and is
anxious to have the facts brought before their
State Leaders, as they have nothing exactly
similar included in their activities at the present
time. The session at which Mr. Bailey spoke
was also addressed by Hon. D. F. Houston, Sec-
retary for Agriculture in the Wilson administra-
tion in the United States. In the course of his
address Mr. Bailey said:

"Having thus endeavored to place before you
something of the organization and objects of the
School Fair movement as it is carried on at the
present time by the Ontario Department of Agri-
culture through its District Representatives, you
may now be interested in something of the pro-
gress it has made. The figures for 1915 are not
entirely complete, but the approximate figures
will serve our purpose.

"Starting with 25 School Fairs in 1912, we
have increased from year to year until this year
they number 234. These embrace 2,291 schools,
which represent approximately one-half of the
rural schools of the Province. The number of
pupils participating was 48,386, while the plots
they looked after on their home farms averaged
more than one each, totalling 51,243. They also
received 6,868 settings of eggs from the bred-to-
lay strain of Plymouth Rocks which is being en-
couraged by the Poultry Department of the Ont-
ario Agricultural College.

"As for the Fairs themselves, the entries num-
bered approximately 120,000, and the attendance
included 75,000 children and 81,000 adults.
These figures speak for themselves in proving
that the School Fair in our Province has struck
a responsive chord in the public opinion of the
rural districts, and as a consequence has met
with willing and enthusiastic support. It will be
evident to all that without the co-operation of
the teachers, inspectors, school trustees and
parents such a remarkable and rapid development
would not have been possible. It must likewise
be evident that such a commendable co-operation
could not have been secured had the idea behind
the Fair not commended itself as being of prac-
tical importance in its influence on the boys and
girls at a formative period in their lives. Bear
in mind also that although the work is financed
largely through the Department, the prize money
is contributed by local sources, and the fact that
it has been so readily forthcoming in the form of
grants by school trustees, by township councils,
and donations by individuals attests at once the
generosity and public spirit of the people con-
cerned and the strong place which the Fair has
made for itself. It is a pleasure to acknowledge
this co-operation and the spirit behind it because
without the assistance of the community as a
whole the best results naturally cannot be
obtained. It is a pleasure also to hear the un-
solicited and enthusiastic expressions of opinion
uttered by parents, of which this quotation from
one enthusiastic parent is a sample:

"Let it be an inspiration to us to keep in
touch with our children's school life, and some
day we'll rise up and call that man Blessed who
instigated the School Fair."

"It may be asked, however, how it is possi-
ble to handle the tremendous amount of organiza-
tion work which is involved in conducting all
these School Fairs. That is a natural question
and is of course one of the problems to be solved.
You will understand, however, that each of our
District Representatives has an assistant, and
now almost all of them have an automobile. The
use of the automobile may be said to double or
treble the effectiveness of the work of the district
officer in handling the School Fairs because at
the time this work is the heaviest, namely, in
the distribution of seed and in the inspection of
plots and the conduct of the Fairs in the fall,
the roads are usually in a condition to permit

the use of a car entirely. In this way a tremen-
dous amount of ground is covered in a short
time. Sometimes it is necessary, and it may in
the future be still more necessary to employ
extra assistance for a month or two during part
of the work, but so far we have not had to re-
sort to this to any very great extent. In the
holding of the Fair dates are arranged so that
adjoining Counties may co-operate, and I think
along these lines with the necessary adjustments
we will be able to take care of the necessary ex-
pansion in the future.

"There is another question, however, which is
sometimes asked, and properly so, and that is,
"Does not the School Fair work take up so much
of the time of the District Representative that it
interferes with the attention which he can devote
to the adult farmer?" In the first place, let me
say that the junior farmer, the boys and girls
on the farm, have so long received so little at-
tention that I do not think we need worry if
their turn has now come to receive more of the
attention of the Department of Agriculture. I
think the hope of the future lies in the attention
which is being devoted to the boys and girls in
the country districts, and for that reason the
work would be abundantly justified even if it did
diminish somewhat the other lines of work which
have been in vogue in the past. I do not admit,
however, that that is the case to any great de-
gree. It may be true that the District Repre-
sentative because of the demands of School Fairs
has less time to devote to some of the heretofore
accepted methods of reaching the adult farmer,
but I submit that the School Fair in itself is
reaching the adult farmer, as well as the junior
farmer. Moreover, it is reaching the adult
farmer who heretofore has never been reached.

"It is generally recognized among those in-
terested that the indifferent farmer is the despair
of the agricultural worker, and that a great deal
of the work which is carried on fails to reach
him entirely. The School Fair is doing some-
thing to solve this difficulty. It is in a consid-
erable degree reaching the indifferent farmer. There
is no more effective way of reaching any farmer
than through his boy or girl, and we have in
our records cases innumerable where the interest
developed in the boy through the School Fair has
been the means of developing a corresponding in-
terest in the father. I have mentioned the fact
that there were 51,000 plots. This means that
a Representative of the Department of Agricul-
ture personally visited approximately 50-
000 farms in connection with School
Fair work, and in these visits he came
in touch with the father and mother in
a large number of cases, as they are naturally in-
terested in what their children are doing. This
opens up a line of usefulness heretofore un-
touched, and the records show that it is accom-
plishing a great deal in implanting in a practical
way the value of pure seed, better cultivation,
better varieties—in a word "better farming"—in
the minds of those whose thoughts have never be-
fore been directed along such lines. To quote
only one or two experiences:

"One man whose boy took Empire State
potatoes last year for his School Fair plot
showed me a sample that the boy was exhibiting
this year and stated that they were the best
potato for his farm that he had yet tried and
that he had enough seed to plant his entire crop
next year and intended to grow nothing else.

"Another man came to me and told me of the
great success his boy had achieved with O. A. C.
No. 72 oats supplied last year. He told me that
from last year's plot they threshed 17 pounds of
oats, well cleaned, and from this 17 pounds this
year they had over 25 bushels of excellent seed.
The boy exhibited a sample of them at the Fair,
and it was certainly No. 1. He ended up by
saying that he had not yet sown an oat plot that
could compare with them.

"Let it not be thought that we consider we
have reached perfection. We believe we have an
idea of assured usefulness and great possibilities
and we are endeavoring to develop it from year
to year. In that development we expect to meet
difficulties and we hope to receive suggestions
from all those who are interested in helping to
overcome these difficulties and assure the
maximum usefulness of the fair idea."

Canada's Exportable Wheat.

The amount of Canadian wheat estimated as
available for export this year has been placed at
223,132,000 bushels. The total yield has also
been officially estimated at 336,258,000 bushels.
The average loss in cleaning and allowance of 10
per cent. for grain not of merchantable quality
is estimated at 33,625,000 bushels. It will re-
quire 24,500,000 bushels to seed 14,000,000
acres for next year's crop, using, on the average,
1 1/2 bushels per acre. Assuming that the average
person will consume 6.25 bushels for food, 50-
000,000 bushels will be required for home use.
The quantity of wheat from the 1915 crop avail-
able for export is 85,558,000 bushels in excess of
the previous high record of 1913-14, and repre-
sents nearly 68 per cent. of the total production
of 1915.

P. E. Island Notes.

Editor "The Farmer's Advocate":

Agriculturally speaking the season of 1915 has
been somewhat disappointing. The crop is short
all over the Island. The excessive wet in plant-
ing time caused potatoes to miss, and the yield
is not more than half a crop on the average.
Oats, especially on the flatter lands, are away
below an average. Wheat on the drier lands
was fair but on the heavier clays was light. The
root crop is not up to an average of recent
years. The hay crop was up to a good average
and this will help out the stockmen some.
The failure in the potato crop is much
against pork business here, as potatoes are the
principal feed used in its production. The con-
sequence is that there is a rush to market in
very thin condition. This has brought the price
down about a cent and a half already. Beef is
in fair demand, but most cattle are thin as the
pastures, which were good the first of the season,
failed almost entirely after September first.
The grain crop was saved in good condition.
Horses are unsaleable, and very many farmers are
wintering from one to three more than they re-
quire on the farm. This will be a serious loss.
Sheep and lambs are selling for a good price.
Poultry is also a fair price. The "Egg Circles"
here have done a very satisfactory business dur-
ing the last season. There is still a very strong
opposition to them from those who formerly
handled the egg business here, but the Circles—
or most of them—seem determined to give co-opera-
tion in this line of business a fair trial before
going back to the old way which got our eggs to
market in such bad condition. Every co-opera-
tive effort of the farmers here has some one to
oppose it, but farmers are waking up to see that
those who oppose them in such ventures are the
people who want to exploit them for their own
selfish ends.

The co-operative dairy business along cheese-
making lines has been as usual a success, and
the return from this branch of our dairy business
will be above the average of recent years. The
butter factories are doing a larger and more
profitable business since the butter is being manu-
factured in a number of centres, and the cream
gathered from considerable distance by train and
otherwise.

The apple crop was practically a failure here.
We are forcibly reminded that a state of war
exists between us and the Central Powers, when
we see our spacious "Agricultural Hall" at the
capital occupied by a heavy battery 200 strong
of our own boys who expect to proceed to the
front soon, their place then to be taken by a
regiment of infantry recently raised here. Short
courses in agriculture and winter shows will like-
ly be cut out for want of accommodation. But
military matters must have precedence "as
Britons never will be slaves." W. S.

Canada's Yield of Fodder Crops.

On November 16, 1915, the Census and
Statistics Office at Ottawa, issued a report re-
garding the root and fodder crop of 1915, the
acreage and condition on October 31 of fall wheat
sown for 1916 and the progress of fall plowing.
Potatoes, turnips, mangels, hay and clover,
alfalfa, fodder corn and sugar beets, this year
occupied a total area of about 8,977,000 acres as
compared with 9,067,000 acres in 1914. The
value of the crop this year has been placed at
230,379,000 as compared with 226,227,000 last
year. The decrease in area is principally in hay
and clover and the increase in total value is due
to the larger yield of the same crop. Hay and
clover, according to the estimate, yielded 1.39
tons per acre as compared with 1.28 tons per
acre last year. Alfalfa in 1915 produced an
average of 2.83 tons per acre, fodder corn, 10
tons per acre, while turnips and other roots
yielded 64,281,000 bushels or 372 bushels per
acre.

Reports regarding the potato crop vary great-
ly from the different provinces. The total esti-
mate of yields is 62,604,000 bushels from 478-
600 acres; an average yield per acre of only 131
bushels. Last year the average was 180 bushels.
In 1910 the rate per acre was 119 bushels which
is remembered as a year of exceedingly small
production in this crop. The 1915 crop is 27
bushels per acre below the average for the five
years, 1910-14. Alberta and British Columbia
report good yields, the former province giving
an average 188.8 bushels per acre, and the latter
247 bushels. For all Canada the quality is
placed at 84 per cent. with 100 as a standard.
Last year it was placed at 90 per cent. Potatoes
are very generally reported as affected with blight
and rot, especially in Ontario and the indications
are that the keeping quality this year will be
very poor.

The Census and Statistics Office estimate that
15 per cent. less fall wheat has been sown this
year than in 1914. The decrease is principally
in Ontario and is due to the heavy rains of
August which prevented the working of the soil
in time for seeding. The area sown to fall wheat
in Ontario is estimated at 820,600 acres as com-

pared with 1,043,000 acres sown in 1914. The decrease being 222,480 acres or over 21 per cent. In Alberta there is a 13 per cent. increase in the acreage sown. In Manitoba there is a decrease from 10,900 acres in 1914 to 9,400 acres in 1915. In Saskatchewan there is no change from the estimated area of 41,000 acres, while in British Columbia there is a small increase this year.

With regard to fall plowing for all of Canada it is estimated at 53 per cent. of the area intended for next year's crop was plowed by October 31 as compared with 71 per cent. at the same date last year and 54 per cent. in 1913. In the Northwest percentages are as follows: Manitoba, 36 against 92; Saskatchewan, 27 against 77; Alberta, 34 against 56.

Ontario's Crops In 1915.

The Ontario Department of Agriculture in its November crop bulletin has summed up the agricultural results for the past summer, basing its remarks upon reports sent in during the first week of this month from 1,000 correspondents. Grains generally have yielded well, but the threshed product is not always of the best quality. The yield of fall wheat, according to this report was considerably above the average per acre. While much of the wheat is of the very finest quality a good deal of the grain was affected by wet-weather harvesting, and became more or less sprouted. Some of it was also damp at threshing. The actual loss, however, will be relatively small, for it can be fed to live stock with satisfactory results. The acreage of fall wheat now growing for the 1916 crop will be about three-fourths of that cut in 1915. It will also be less than the average in 1914. The experience with spring wheat was similar to that with fall wheat. A good yield but an uneven quality of grain, owing to the wet weather at harvesting, prevailed. There was a splendid yield of barley, but much of it was discolored by the rain. The net result of the oat crop was on the whole satisfactory. The yield per acre was much above the average in spite of the fact that a good deal of the crop was knocked down by the heavy rain storms and that owing to the late harvesting there was considerable shelling. Farmers do not appear to be enthusiastic over the results of the pea crop. Little, however, has been said in the report about the weevil. Correspondents also recommend the practice of mixing late barley and early oats, which ripen very well together. The yields were good and the feeding value for live stock considerably above that of separate grains. Reports vary as to the quality of the corn, there being some complaints of soft cobbing owing to the long rainy season, but taken altogether the crop may be counted a satisfactory one. Silo corn did relatively better than that growing for husking. The season was too wet for the best results from the bean crop. The beans are more or less discolored and with this crop appearance is a very important factor. Clover did better for a second cutting of hay than it did for seed. Threshing results have been comparatively light. The frequent rains made too rank a growth of plants

and much of the seed failed to mature notwithstanding the promising bloom.

The potato crop was most promising early in the season but when harvesting time came the results may be termed a failure. A few correspondents report excellent yields on high, sandy land, but on heavy clay and low-lying spots rot was so prevalent that in many cases they were not lifted at all. Mangels did better than turnips, the former crop running from fair to excellent while the latter was described as fairly good.

Regarding fruit the report says, "where orchards have been taken care of they have done well, but where untreated the San Jose scale and the tent caterpillar have wrought considerable harm. Apples suffered from the codling moth although there was little complaint of scab this season." We fear that fruit growers in general may take exception to these reports for quality in fruit this year was very much below par even where pretty thorough spraying was carried on.

Fall pastures were never better in the opinions of those reporting. Live stock are all in good form, showing remarkable freedom from disease. More calves are being kept than in former years. Sheep have been in good demand, especially in regard to the lambs which in many cases have been finished off on rape. Hogs have been shipped regularly, and while some correspondents report a scarcity of young pigs others claim that there is a normal supply on hand. Silos are being erected all over the province in larger numbers than ever.

The milch cow this year has been queen. The province never had such a season for dairy products. Owing to the excellent condition of pastures up to the first of November the flow of milk was unusually full and steady, and in some factories as much cheese was made in October as in August. In fact cheese factories, creameries, and condenseries have been going ahead all season at full speed, and the prices have been most satisfactory to the producer.

Correspondents are divided regarding the profit from fowl. No records of any account have been kept, yet some claim that the profit per hen per annum amounts to \$1.00. This season there have been more complaints than usual of poor hatching. There has been a good demand for crate-fattened fowl.

Owing to the continuous wet weather prevailing fall work was belated, thus making fall plowing less extensively executed than in former seasons. The land was hard packed owing to the heavy pounding of frequent rains, but plows were going lively all over the province during the first week of November.

There was a sufficiency of farm labor during the first part of the season. Much of it however, was of indifferent quality. Conditions changed during the season and a scarcity of labor existed for fall work, which was heavier than usual owing to the very much belated harvest.

There is a relatively large supply of fodder on hand owing to the fine crop of corn and the large quantity of grain caught by the wet weather and rendered inferior for marketing purposes, but good for feeding live stock.

Drying Seed Corn.

Editor "The Farmer's Advocate":

A short time ago we read in your valuable paper a method of drying corn for seed. I would like to give our method and also how we come to have our own seed corn. After putting in all the vegetable seeds, plants, early potatoes and so on which we would require for the summer, winter and up to garden time again, we still had a small space of our garden plot vacant. Having a bit of last year's purchased seed corn left we decided to plant it and if possible produce our own seed corn for the coming year. It was planted shortly after the other things, when it would be clear of frosts. It was sowed in rows, not hills, about two feet apart and not very thick. Off a very small space we have about four bushels of fine seed corn, many of the ears are a good size and about fourteen inches long. It has also been tested and the very poorest of it grows fine. We went through the standing corn and picked the ears as the husks looked dead and dry on them. We then removed all the silk, and all the husks except one or two. By these the ears were braided and then hung on nails in a dry place. We now have the braids hanging in a big, airy room upstairs and they have long been as dry as could be. Of course all husks came off some cobs in spite of us. These we threw on a wire rack and they dried nicely. We found this a very easy and good method of drying, but of course with more corn it might not be so easy. We have dried our popcorn and sweet corn this way for several years now and have no trouble in keeping it. When we're sure it's dry if we don't want it hanging around we put it in bags and keep it in a dry place. Northumberland Co., Ont. H. A. C.

Hay May Come In.

The Order under "The Animal Contagious Diseases Act," of date the 9th of September, 1915, as amended by Orders of date the 28th of October and 9th of November, 1915, is hereby further amended by substituting for paragraph (27) the following:

"Hay may be admitted from the States of Michigan and Vermont provided each shipment is accompanied by the affidavit of the owner or shipper that the said hay is the product of either of the states aforesaid, and has not been exposed to the infection of foot and mouth disease."

Dated at Ottawa this 15th day of November, 1915.

(Sgd.) GEO. F. O'HALLORAN, Deputy Minister of Agriculture.

More Seats at the Winter Fair.

In talking with R. W. Wade, Secretary of the Ontario Provincial Winter Fair a few days ago he happened to remark that there will this year be at least one-third more seating capacity at the ringside in the judging arena at Guelph. This means that one-third more people can see what they go to the Fair to see—the judging. Let no one stay away. There should be seats for all.

Toronto, Montreal, Buffalo, and Other Leading Markets.

Toronto.

Receipts of live stock at the Union Stock Yards, West Toronto, from Saturday, November 20, to Monday, November 22, numbered 25 cars, comprising 4,074 cattle, 681 hogs, 1,497 sheep and lambs, 144 calves, and 760 horses in transit. Quality mostly common. Trade steady. Choice heavy steers, \$7.50 to \$7.90; choice butchers' cattle, \$7 to \$7.35; good, \$6.65 to \$6.85; medium, \$6 to \$6.40; common, \$4.90 to \$5.75; cows, \$3.25 to \$6.25; bulls, \$4.25 to \$6.75; feeders, \$6 to \$6.25; stockers, \$4 to \$5.50; milkers, \$7 to \$100; calves, \$3.75 to \$4.50. Sheep, \$4 to \$6.65.

REVIEW OF LAST WEEK'S MARKETS

The total receipts of live stock at the City and Union Stock-yards for the past week were:

	City.	Union.	Total.
Cars	58	743	801
Cattle	932	11,570	12,502
Hogs	574	7,139	7,713
Sheep	1,817	8,283	10,100
Calves	83	683	766
Horses	—	2,447	2,447

The total receipts of live stock at the two markets for the corresponding week of 1914 were:

	City.	Union.	Total.
Cars	63	638	701
Cattle	890	9,425	10,305
Hogs	850	11,509	12,359
Sheep	2,512	11,274	13,816
Calves	80	656	736
Horses	—	32	32

The combined receipts of live stock at the two markets for the past week show an increase of 100 car loads, 2,197 cattle, 30 calves and 2,415 horses; but, a decrease of 4,646 hogs and 3,716 sheep and lambs compared with the corresponding week of 1914.

The butcher cattle trade opened strong on Monday to a 20c. advance, and continued steady until Thursday, when an unusually heavy run for the fourth day made slow trading, and prices dropped back 25c., with not a few cars left unsold. During the week, Corbett, Hall & Coughlin handled seven cars of choice heavy steers at \$7.50 to \$8, the closing price, however, being from \$7.40 to \$7.75. Common, rough, and light Eastern steers and heifers suffered the most in the break, and were very slow, at \$4.90 to \$5.40. Stockers and feeders, due to the falling off of American orders, finished very badly, and lost 25c. to 50c. per cwt. Choice, dehorned feeders, 800 to 900 lbs., sold around \$6.25; good feeders went at \$5.50 to \$6, and common, light, stock steers and heifers, \$4 to \$4.75. Steers and bul's of the weighty kind, 1,000 lbs., for distillery feeding, were still high priced—steers, \$6.40 to \$6.80; bulls, \$5 to \$5.50—but this buying will not last long. Milkers and springers were in demand from many quarters, and were firm, at \$7 to \$105. One car of choice Holstein cows, weighing 1,300 lbs., and all inspected, were shipped on order to Louisville, Kentucky. Calves had a hard week, and were 50c.

to 75c. per cwt. lower. Grass calves were held over at \$3.75 to \$4.50. Heavy fat calves were priced at \$5.75 to \$7, and veals at \$8.50 to \$9.50, and only an exceptional calf will bring 10c. per lb. Lambs and sheep were very strong, although the quality of the lambs was not so good. Choice light lambs brought \$9.10 to \$9.25; medium \$9, and heavies \$8.60 to \$8.85. More light sheep than usual brought \$6.50 to \$6.60, and selected ones \$6.75. Heavy sheep of the best grade were \$5 to \$5.50, with \$3 to \$4 for culls. Hogs, due to outside orders and very light receipts (there were 5,000 less than same week last year), were advanced 75c. since the previous week, and sold at \$9.40 to \$9.50, fed and watered. The f. o. b. price was \$8.80, but will improve.

Butchers' Cattle.—Choice heavy steers at \$7.40 to \$7.75; choice butchers' cattle at \$7 to \$7.30; good at \$6.65 to \$6.85; medium at \$6 to \$6.40; common at \$5.25 to \$5.75; light steers and heifers at \$4.90 to \$5.20; choice cows at \$5.90 to \$6.25; good cows at \$5.40 to \$5.75; medium cows at \$4.90 to \$5.25; common cows at \$4.25 to \$4.75; canners and cutters at \$3.25 to \$4.50; light bulls at \$4.25 to \$5; heavy bulls at \$5.50 to \$6.75.

Stockers and Feeders.—Choice feeders, 900 to 950 lbs., at \$6 to \$6.25; good feeders, 800 to 900 lbs., \$5.50 to \$6; good stockers, 700 to 800 lbs., at \$5 to \$5.50; common stocker steers and

heifers at \$4.20 to \$4.75; yearlings, 600 to 650 lbs., at \$5.75 to \$6.15. Milkers and Springers.—Choice milkers and springers at \$90 to \$100; good cows at \$70 to \$85; common cows at \$45 to \$65. Veal Calves.—Extra choice at \$10; choice veal calves at \$9 to \$9.50; good at \$7.25 to \$8.50; medium at \$5.75 to \$6.75; common at \$4.75 to \$5.25; grass at \$3.75 to \$4.50. Sheep and Lambs.—Light sheep at \$6 to \$6.50; heavy sheep at \$4.50 to \$5.50; lambs at \$8.75 to \$9.25; cull lambs at \$6.75 to \$7.50.

Hogs.—Selects, fed and watered, \$9.40 to \$9.50; f. o. b., \$8.80; 50c. is being deducted for heavy, fat hogs, and thin, light hogs; \$2.50 off for sows, and \$4 off for stags, from prices paid for selects.

Ontario Wheat.—No. 2 winter, per car lot, 96c. to 98c., according to freights, outside; slightly sprouted, 92c. to 95c., according to sample; sprouted, smutty and tough, 75c. to 88c., according to sample. Manitoba wheat (new crop)—No. 1 northern, \$1.13, track, lake ports, immediate shipment; No. 2 northern, \$1.10, track, lake ports, immediate shipment; No. 2 Canada Western, 47½c., track, lake ports.

Ontario Oats (new crop).—No. 3 white, 39c. to 40c., according to freights, outside; commercial oats, 38c. to 39c. Manitoba oats—No. 3 Canada Western, tough, 44½c., track, lake ports.

Ontario Oats (new crop).—No. 3 white, 39c. to 40c., according to freights, outside; commercial oats, 38c. to 39c. Manitoba oats—No. 3 Canada Western, tough, 44½c., track, lake ports.

Ontario Oats (new crop).—No. 3 white, 39c. to 40c., according to freights, outside; commercial oats, 38c. to 39c. Manitoba oats—No. 3 Canada Western, tough, 44½c., track, lake ports.

Ontario Oats (new crop).—No. 3 white, 39c. to 40c., according to freights, outside; commercial oats, 38c. to 39c. Manitoba oats—No. 3 Canada Western, tough, 44½c., track, lake ports.

Ontario Oats (new crop).—No. 3 white, 39c. to 40c., according to freights, outside; commercial oats, 38c. to 39c. Manitoba oats—No. 3 Canada Western, tough, 44½c., track, lake ports.

Ontario Oats (new crop).—No. 3 white, 39c. to 40c., according to freights, outside; commercial oats, 38c. to 39c. Manitoba oats—No. 3 Canada Western, tough, 44½c., track, lake ports.

Ontario Oats (new crop).—No. 3 white, 39c. to 40c., according to freights, outside; commercial oats, 38c. to 39c. Manitoba oats—No. 3 Canada Western, tough, 44½c., track, lake ports.

Ontario Oats (new crop).—No. 3 white, 39c. to 40c., according to freights, outside; commercial oats, 38c. to 39c. Manitoba oats—No. 3 Canada Western, tough, 44½c., track, lake ports.

Drying Seed Corn.

The Farmer's Advocate":
 time ago we read in your valuable method of drying corn for seed. I would our method and also how we come our own seed corn. After putting in all seeds, plants, early potatoes and so we would require for the summer, win- to garden time again, we still had a of our garden plot vacant. Having st year's purchased seed corn left we plant it and if possible produce our corn for the coming year. It was uly after the other things, when it ear of frosts. It was sowed in rows, about two feet apart and not very a very small space we have about s of fine seed corn, many of the ears size and about fourteen inches long. been tested and the very poorest of it We went through the standing corn the ears as the husks looked dead them. We then removed all the husks except one or two. By ars were braided and then hung on- dry place. We now have the braids a big, airy room upstairs and they em as dry as could be. Of course all off some cobs in spite of us. These n in a wire rack and they dried nicely. is a very easy and good method of of course with more corn it might asy. We have dried our popcorn and this way for several years now and ble in keeping it. When we're sure we don't want it hanging around we gs and keep it in a dry place.
 rland Co., Ont. H. A. C.

Hay May Come In.

r under "The Animal Contagious t," of date the 9th of September, ended by Orders of date the 28th of 9th of November, 1915, is hereby ndered by substituting for paragraph owing:
 y be admitted from the States of l Vermont provided each shipment is by the affidavit of the owner or the said hay is the product of either aforesaid, and has not been exposed on of foot and mouth disease."
 Ottawa this 15th day of November,

(Sgd.) GEO. F. O'HALLORAN,
 Deputy Minister of Agriculture.

Seats at the Winter Fair.

with R. W. Wade, Secretary of the ncial Winter Fair a few days ago he remark that there will this year be third more seating capacity at the the judging arena at Guelph. This one-third more people can see what the Fair to see—the judging. Let no ay. There should be seats for all.

Trading Markets.

heifers at \$4.20 to \$4.75; yearlings, 600 to 650 lbs., at \$5.75 to \$6.15.
 Milkers and Springers.—Choice milkers and springers at \$90 to \$100; good cows at \$70 to \$85; common cows at \$45 to \$65.
 Veal Calves.—Extra choice at \$10; choice veal calves at \$9 to \$9.50; good at \$7.25 to \$8.50; medium at \$5.75 to \$6.75; common at \$4.75 to \$5.25; grass at \$3.75 to \$4.50.
 Sheep and Lambs.—Light sheep at \$6 to \$6.50; heavy sheep at \$4.50 to \$5.50; lambs at \$8.75 to \$9.25; cull lambs at \$6.75 to \$7.50.
 Hogs.—Selects, fed and watered, \$9.40 to \$9.50; f. o. b., \$8.80; 50c. is being deducted for heavy, fat hogs, and thin, light hogs; \$2.50 off for sows, and \$4 off for stags, from prices paid for selects.
 BREADSTUFFS.
 Ontario Wheat.—No. 2 winter, per car lot, 96c. to 98c., according to freights, outside; slightly sprouted, 92c. to 95c., according to sample; sprouted, smutty and tough, 75c. to 88c., according to sample. Manitoba wheat (new crop)—No. 1 northern, \$1.13, track, lake ports, immediate shipment; No. 2 northern, \$1.10, track, lake ports, immediate shipment; No. 2 Canada Western, 47½c., track, lake ports.
 Ontario Oats (new crop).—No. 3 white, 30c. to 40c., according to freights, outside; commercial oats, 38c. to 39c. Manitoba oats—No. 3 Canada Western, tough, 41c., track, lake ports.

THE ROYAL BANK OF CANADA

Capital Authorized - - - \$ 25,000,000
 Capital Paid up - - - 11,500,000
 Reserve Funds - - - 13,000,000
 Total Assets - - - 180,000,000

HEAD OFFICE: MONTREAL

Branches throughout every Province of the Dominion of Canada

Accounts of Farmers Invited
 Sale Notes Collected

Savings Department at all Branches

American Corn.—No. 2 yellow, 74½c., track, Toronto. Canadian corn—No. 2 yellow, 74c., track, Toronto.
 Peas.—No. 2, nominal, per car lot, \$2.10; sample peas, according to sample, \$1.25 to \$1.75.
 Barley.—Good malting barley, 56c. to 60c., according to freights, outside; feed barley, 47c. to 52c., according to freights, outside.
 Buckwheat.—Nominal, car lots, 78c. to 80c., according to freights, outside.
 Rye.—No. 1 commercial, 88c. to 90c., according to freights, outside; tough, 80c. to 85c., according to sample.
 Manitoba Flour.—First patents, in jute bags, \$5.85, Toronto; second patents, in jute bags, \$5.35, Toronto; strong bakers', in jute bags, \$5.15, Toronto. Ontario Flour.—New winter, \$4.10 to \$4.50, according to sample, seaboard or Toronto freights, in bags, prompt shipment.

HAY AND MILLFEED.
 Millfeed (car lots, delivered).—Bran, per ton, \$21; shorts, per ton, \$23; middlings, per ton, \$25; good feed flour, per bag, \$1.45.
 Hay.—No. 1, per ton, \$16 to \$17.50, track, Toronto.
 No. 2, per ton, \$13 to \$14, track, Toronto.
 Straw.—Car lots, per ton, \$6.50 to \$7, track, Toronto.

COUNTRY PRODUCE.
 Butter.—Butter remained stationary on the wholesales during the past week. Creamery pound squares sold at 32c. to 33c. per lb.; creamery solids at 31c. per lb., and separator dairy butter at 29c. to 30c. per lb.
 Eggs.—New-laid eggs and cold-storage variety both remained stationary in price on the wholesales during the past week.
 New-laid eggs, 45c. to 50c.; cold-storage, 30c. to 33c. per dozen, wholesale.
 Cheese.—New, 17c. to 17½c. per lb.
 Honey.—Extracted, 10c. to 11c.; comb, \$2.50 to \$3 per dozen sections.
 Beans.—Hand-picked, \$4.25 per bushel; primes, \$3.90 and \$4 per bushel.
 Potatoes.—Potatoes advanced again, the New Brunswick Delawares being quoted at \$1.40 per bag, by the car lot, and Ontarios at \$1.25 per bag, car lot.
 Poultry.—Live weight: Turkeys, per lb., 16c.; spring ducks, 11c. to 12c. per lb.; geese, 10c. per lb.; spring chickens, 12c. to 13c. per lb.; fowl, heavy, 11c. per lb.; light, 8c. per lb.; squabs, per dozen, 10 ounces, \$3.60 (dressed).

HIDES AND SKINS.
 City hides, flat 18c.; country hides, cured, 17c.; country hides, part cured, 16c.; country hides, green, 15c.; calf skins, per lb., 18c.; kip skins, per lb., 16c.; sheep skins, \$1.50 to \$2; horse hair, per lb., 35c.; horse hides, No. 1, \$3.50 to \$4.50; sheep skins and felts, \$1.20 to \$1.35; sheep skins, \$1.50 to \$2; tallow, No. 1, per lb., 5½c. to 7c.; wool, washed, fine, per lb., 40c.; wool, combed, washed, per lb., 35c.; wool, unwashed, fine, per lb., 30c.; wool, unwashed, coarse, per lb., 28c.; rejections, per lb., 28c.

FRUITS AND VEGETABLES.
 The first car of British Columbia boxed apples reached the market on Tuesday of last week, when the manner in which they were packed in the car was a revelation to the local trade. Each variety and size were clearly enumerated on a sheet as it is packed in the car, so that the consignee knows just where to go

for any one he wants. The quality of the apples is splendid, and they only need to be tasted to prove their superiority over the American boxed apples.

Potatoes advanced again Thursday, the New Brunswicks selling at \$1.45 and \$1.50 per bag, and the Ontarios at \$1.35 per bag.
 Apples—20c. to 60c. per 11-quart basket; Snow apples, \$3 to \$6 per barrel; Spys, \$4 to \$5.50 per barrel; Greenings and Baldwins, \$3 to \$4.50 per barrel; Russets, \$3 to \$4.50 per barrel; imported, \$2.25 to \$3 per box.
 Bananas—\$1.50 to \$2 per bunch.
 Citron—40c. per dozen.
 Cranberries—\$7 to \$8.75 per barrel; \$2.75 per box.
 Grapefruit—Jamaica, \$4 per case; Porto Rico, \$4 to \$5 per case; Florida, \$4 to \$4.75 per case.
 Grapes—Malaga, \$6 to \$8.50 per keg; Emperors, \$2.75 per case, \$4.75 per keg; Canadian blues, 15c. to 20c. per 6-quart basket; Red Rogers, 15c. to 25c. per 11-quart basket.

Lemons—California, \$4 to \$4.50 per case; Verdilli, \$3.25 to \$3.50 per case.
 Limes—\$1.50 per hundred.
 Oranges—Jamaica, \$3.50 per case; late Valencias, \$5 to \$6 per case; Floridas, \$3 to \$3.25 per case.
 Pears.—Imported, \$1 to \$1.50 per small and \$3.75 per large case; Bartletts, \$3 per bushel; Canadian Keifers, 30c. per 11-quart basket; Anjous, 60c. to 75c. per 11-quart.
 Pineapples—Porto Rico, 24's, \$4 to \$4.50 per case; 30's, \$3.75 per case.
 Pomegranates—Spanish, \$3.75 per case; California, \$3 per case.
 Pumpkins—50c. per dozen.
 Tomatoes—Imported, \$3.50 to \$4 per case; hothouse, No. 1's, 25c. to 27c. per lb.; No. 2's, 23c. per lb.
 Artichokes—30c. to 35c. per 11-quart basket.

Beans—Green, \$3.50 per hamper.
 Beets—50c. to 60c. per bag.
 Brussels Sprouts—Imported, 20c. per quart; Canadian, 60c. to 75c. per 11-quart basket.
 Cabbage—30c. to 40c. per dozen, 60c. to 85c. per barrel.
 Cauliflower—\$1 to \$2 per dozen, \$3 to \$3.50 per barrel.
 Carrots—New, Canadian, 65c. to 75c. per bag.
 Celery—15c. to 40c. per dozen; Thedford, \$3.50 to \$4 per case.
 Cucumbers—Hothouse, \$1.75 to \$2.25 per dozen, \$1.50 per six-quart basket.
 Lettuce—Boston head, \$1.50 to \$1.75 and \$2.25 per case of two dozen; leaf lettuce, 20c. to 30c. per dozen.
 Mushrooms—Imported, \$2.50 to \$3 per six-quart basket.
 Onions—25c. to 30c. per 11-quart basket; No. 1's, \$1.25 to \$1.35 per 75-lb. bag; Spanish onions, \$1.65 to \$1.75 per small case.
 Parsnips—65c. to 80c. per bag.
 Peppers—Sweet, green, imported, 75c. per basket.
 Squash—Hubbard, 50c. to \$1 per dozen.
 Sweet Potatoes—\$1.35 per hamper.
 Turnips—40c. per bag.

Montreal.

Live Stock.—Although live stock is becoming scarce everywhere, the price showed practically no change on the local market. Some choice steers were offered, and the prices for these ranged from 7c. to 7½c. per lb. For the most part, however, trading was in medium quality, the price of which ranged from 6c. to 6½c. per lb., while the commoner sorts sold down to 4½c. Butchers' cows and bulls ranged generally from 4½c. to 6½c., covering all qualities. Americans were in the market for canning cattle, and prices were moderately firm, with cows selling at 3½c. to 3¾c., and bulls at 4c. to 4½c. Americans were also buyers of lambs, and Ontario stock sold at 9c. to 9½c., while Quebec sold at 7½c. to 7¾c. Sheep sold at 5½c. to 6c. per lb. Calves were also being shipped out of the United States, and grass-fed stock sold at 2c. to 6c. per lb., and milk-fed stock met a fair demand for local consumption at 7c. to 8c. Selected hogs sold at 9½c. to 9¾c. per lb., weighed off cars.
 Horses.—Demand for horses was dull. Prices were steady, as follows: Heavy draft, weighing from 1,500 to 1,700 lbs., \$225 to \$275 each; light draft, 1,400 to 1,500 lbs., \$175 to \$225; small horses,

\$100 to \$150 each; culls, \$50 to \$75, and fine saddle and carriage animals, \$200 to \$250 each.

Dressed Hogs.—Trade in dressed hogs continued active, and prices held steady, at 13c. to 13½c. per lb. for abattoir-dressed, fresh-killed stock.
 Potatoes.—The price of potatoes continues to advance. Good stock was scarce, and higher than at any time last year. Carloads of Green Mountains were selling at \$1.15 to \$1.20 per bag of 90 lbs., ex track, and of Quebec stock at \$1.10, ex track. In a smaller way, dealers add about 10c. to these figures.

Honey and Syrup.—Both honey and syrup are meeting with a fair demand. Prices were 14c. to 14½c. per lb. for white-clover comb honey, and 11½c. to 12½c. for brown, white extracted being 11½c. to 12c., and brown extracted 10c. Buckwheat honey was 8c. to 8½c. per lb. Maple syrup sold at 90c. to 95c. per 8-lb. tin; \$1.05 for 10-lb. tins; \$1.45 for 12-lb. tins, and 12½c. per lb. for sugar.

Eggs.—New-laid eggs are already becoming hard to get, but prices were already high, so there was no change. Prices were 42c. per dozen for fresh-laid; 33c. for selected; 30c. for No. 1 candled, and 27c. to 28c. for No. 2 candled.
 Butter.—Receipts were up to the average at this time of the year, though domestic consumption is rather lower. The market was slightly easier last week, being quoted in the vicinity of 32c. to a fraction under that figure, for choicest, in a wholesale way, while fine was 31½c. to 31¾c., and seconds around 30½c. to 31c. Dairy butter showed no change, selling at 26c. to 27c. per lb.
 Cheese.—Export is going on in a satisfactory manner. There was no change in the market during last week. Finest colored cheese was still quoted at 16½c. to 17c. per lb., white being about ½c. to ¾c. below these prices. Finest Eastern cheese was 16½c., and undergrades were 15c. to 15½c.

Grain.—Wheat went up during the week, and the market appeared strong. The price of oats advanced a cent. No. 2 white, Ontario and Quebec oats, were 47c.; No. 3 white, 46c., and No. 4 white, 45c. per bushel, ex store. American No. 4 corn sold at 70½c. per bushel, ex track, and No. 2 yellow at 77½c. to 78c., ex store.
 Flour.—Scarcity of supplies and firmness of the wheat market brought about an advance in the market for all grades of flour, both Manitobas and Ontarios. Manitoba first patents were \$6.10; seconds \$5.60, and strong bakers' \$5.40 per barrel, in bags. Ontario patents were \$6, and straight rollers \$5.80 to \$5.40 per barrel, in wood, the latter being \$2.55 per bag.

Millfeed.—Bran is becoming quite scarce, and as the demand is fairly active, millers have advanced their price \$1 per ton. There is a little enquiry from the United States, but no sales have taken place. Bran was \$22 per ton, shorts being \$23, middlings \$29 and \$30, pure grain mouille \$32, and mixed \$30 per ton in bags.
 Hay.—Baled hay was steady, at \$19 per ton for No. 1 baled hay; \$18.50 for extra good No. 2; \$17.50 to \$18 for No. 2; and \$15.50 and \$16.50 per ton, ex track, for No. 3.

Hides.—Prices held steady. Nos. 3, 2 and 1 hides were 20c., 21c. and 22c. per lb., respectively; Nos. 2 and 1 calf skins were 18c. and 20c. per lb.; lamb skins were \$1.60 each; horse hides were \$1.75 and \$2.50 each for Nos. 2 and 1. Rough tallow sold at 1½c. to 2½c. per lb., and rendered at 6c. to 7c. per lb.

Chicago.

Cattle.—Beeves, \$7.50 to \$10.25; cows and heifers, \$2.75 to \$8.20; calves, \$6 to \$9.75.
 Hogs.—Light, \$5.65 to \$6.50; mixed, \$5.85 to \$6.70; heavy, \$6 to \$6.75; rough, \$6 to \$6.20; pigs, \$3.75 to \$5.60.
 Sheep and Lambs.—Lambs, native, \$6.50 to \$9; ewes, \$3.75 to \$5.50.

Cheese Markets.

Vankleek Hill, 16½c.; Brockville, 17 9-16c.; Kingston, 16½c.; Montreal, finest Westerns, 17c.; finest Easterns, 16½c.; New York, State whole milk flats, held specials, 16½c.; average fancy, 16½c.; specials, 15½c.; average fancy, 15½c.; Campbellford, 16½c.; Iroquois, 17c.; Victoriaville, Que., 16 9-16c.; Picton, 17 5-16c.; Napanee, 17½c.

Buffalo.

Cattle.—Best native shipping steers sold at \$9 per hundredweight, and a load of 1,600-lb. Canadian steers reached \$8.75, best Canadians generally running from \$8.25 to \$8.40. Some light, commonish kinds sold down to \$7 to \$7.35. Demand on all grades of cattle at the present time appears to be stronger for the choice grades than the medium and fair kinds. Stocker and feeder demand has lightened up considerably and sellers generally are expecting lower prices on these. A fair kind of stockers are selling around \$5.25 and eight hundred pound kinds, that are taken by Ohio feeders are running as low as \$5.75 to \$6. It requires the best qualified and dehorned feeders to reach seven cents and they must have some flesh. Bull trade has shown little change during the past several weeks but a light, common kind are not selling as readily as the fat and better grades. Fancy milch cows are bringing up to \$100 and better but a medium class of these are rather slow sale, as dairymen do not care to carry these fair kinds of cows through the winter on feed, when the better ones are available. Receipts the last week were 8,625 head, as against 9,075 head for the previous week.

Shipping Steers.—Choice to prime natives, \$9 to \$9.25; fair to good, \$8.50 to \$8.75; best Canadians, \$8.40 to \$8.75; fair to good, \$7.35 to \$8; medium and plain, \$6.75 to \$7.25.

Butchering Steers.—Choice heavy, \$8 to \$8.25; fair to good, \$7.25 to \$7.75; best handy, \$7.50 to \$8; common to good, \$6.25 to \$6.75; light, thin, \$5.25 to \$5.50; yearlings, prime, \$8 to \$9; yearlings, common to good, \$7 to \$7.75.

Cows and Heifers.—Prime weighty heifers, \$7 to \$7.50; best handy butcher heifers, \$7 to \$7.25; common to good, \$5.75 to \$6.60; best heavy fat cows, \$6 to \$6.25; best butchering cows, \$5.50 to \$5.75; medium to good, \$4.75 to \$5.25; cutters, \$4 to \$4.50; canners, \$2.50 to \$3.35.
 Bulls.—Best heavy, \$6.75 to \$7; good butchering, \$6.25 to \$6.50.

Stockers and Feeders.—Best feeders, \$6.75 to \$7; common to good, \$5.50 to \$6.25; best stockers, \$6 to \$6.50; common to good, \$4.50 to \$5.75; good yearlings, \$6 to \$6.50; common, \$4.58 to \$5. Milkers and Springers.—Good to best, in small lots, \$90 to \$100; in car loads, \$65 to \$75; medium to fair, in small lots, \$55 to \$65; in car loads, \$50 to \$60.

Hogs.—All marketing points showed heavy receipts last week, and prices struck another new low level for the season. Buffalo's run Monday reached around 28,000 head and while a few weighty grades sold from \$7.15 to \$7.25, bulk of the crop moved at \$7 and pigs landed at \$6.50. Tuesday's market was strong on heavies, top being \$7.35, light mixed grades and yorkers were steady to a nickel lower and pigs were fully a half dollar higher. Wednesday nothing brought above \$7, bulk selling from \$6.75 to \$6.85, with pigs generally \$6.50; Thursday's range, outside of lights and pigs, was from \$6.80 to \$7, and Friday the top was \$7.10, with the bulk landing at \$6.90. Pigs mostly \$6.50, roughs \$5.60 to \$5.75, latter kinds the fore part of the week selling up to \$6 and stags went mostly from \$5.25 down. Receipts last week reached approximately 53,800 head, being against 55,857 head for the previous week, and 1,060 head for the same week a year ago.

Sheep and Lambs.—Lamb values showed a narrow range last week, tops the first five days selling from \$9 to \$9.10; culls from \$8.25 down. Top yearling wethers ranged from \$7 to \$7.50, few bringing \$7.65, outside quotation for choice wether sheep was \$6, and the general run of sales on ewes were made from \$5 to \$5.25. Receipts last week were 26,400 head, previous week there were 26,898 head and for the corresponding week a year ago, which was right after the quarantine, the run figured only 3,840 head.

Calves.—Friday's supply included about 400 head of Canadian, mostly grassers, and they were still in first hands up to a late hour in the day without bids. Receipts last week were 2,150 head, as compared with 3,103 head for the week before, and 600 head for the same week a year ago.

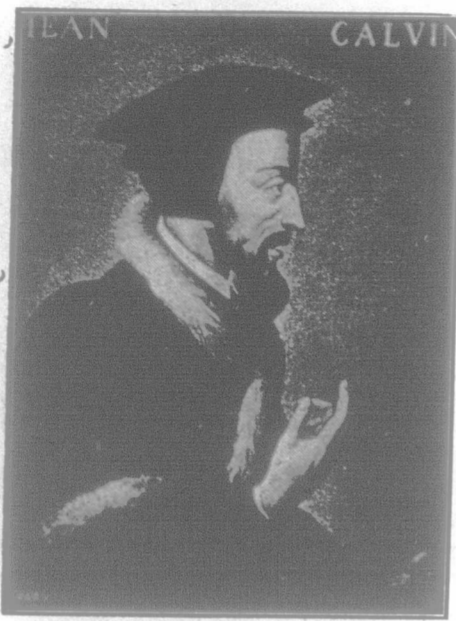
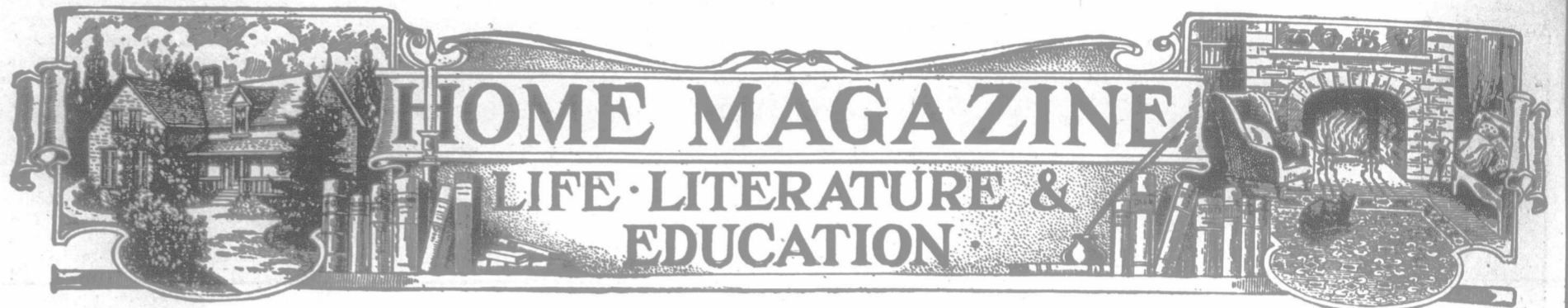

John Calvin, a Great Reformer.

The Day.

By Charles Alexander Richmond.

Twelve mailed men sat drinking late,
The wine was red as blood.
Cried one, "How long then must we wait
Ere we shall thunder at the gate,
And crush the cursed brood?"
Twelve men of iron, drinking late,
Strike hands, and pledge a cup of hate;
The Day!

Twelve men met at the day's decline—
Eleven and One beside.
Their every thought, a thought benign,
Yet One—the One we call divine—
Next day was crucified.
Twelve men of God raised up the sign
And pledged in consecrated wine;
The Day!

Now nineteen hundred years have passed:
The day—whose shall it be at last,
Oh Christ!

Travel Notes.

FROM HELEN'S DIARY.

Geneva, Switzerland, Oct. 16, '15.

Again we have changed our town, but not our lake. We have just moved on down to the other end of Lake Geneva. In the phraseology of the poet, Geneva is the place where the Rhone bids the lake farewell and speeds away southward to join the beautiful blue Mediterranean. The Rhone that flows into the lake near Montreux, is a dismal, opaque drab; the Rhone that flows out of the lake at Geneva is purged and purified, and of a glorious blue, as clear as crystal.

Six bridges connect the two sides of the city. The old town on the left bank creeps up the hillside to the old cathedral, and is full of memories of Geneva's restless history. There is a good deal of Calvin in the old town. In fact, you can't escape from that grim, disagreeable Reformer. There is a Calvin street and a Calvin house; there is the church in which he preached and the academy he founded; the art gallery contains gloomy portraits of him, and there are busts of him in various places. And now, there is a mammoth monument being erected depicting the History of the Reformation, in which there is a stone-carved Calvin of gigantic proportions.

But there is also in Geneva a monument which does not redound to Calvin's glory—the one erected in memory of Michel Servet, the Spanish doctor who was burned at the stake by Calvin's

order because he had written a treatise against the doctrine of the Trinity. This monument is a large, upright slab of granite, rough-hewn except where the lettering is carved. On one side of the marble slab is this inscription:

Michel Servet de Villeneuve d' Aragon,
Born Sept. 27, 1511.

Died at the Stake, Oct. 27, 1553.

On the other side is this sentence:

Condemning this execution as an error peculiar to that age, this expiatory monument was erected on Oct. 27, 1903, by respectful and grateful followers of Calvin, who are firm believers in liberty of conscience, and the principles of the Reformation and the Gospel.

Old Geneva is sprinkled with tablets of celebrated people who have honored the city with their presence. When I was out on a prowl the other day I came upon them in all sorts of queer, out-of-the-way streets. On one shabby corner I saw a tablet on the house wall with this inscription:

George Eliot.
(Miss Evans).

Celebrated English authoress, lived in this house Oct. 1849-March 1850.

Not far from this was the house in which Rousseau was born. And a little farther on the house once occupied by Liszt. Large-sized tablets on both houses. Then I came to the church in which John Knox preached for two years. Extra large tablet on that. And I passed many other tabletted houses bearing names I never heard of before. They have a way here of naming streets after men of note, and then, for the enlightenment of the public, they put up tablets at prominent corners stating who the men were and what they did. Some of them seem to have done nothing more extraordinary than have opinions of their own. But that was rank heresy in Calvin's time.

I am terribly ashamed to confess it, but I always thought Calvin was a Scotchman. I was perfectly astonished to read in the history of Geneva that he was a Frenchman. Since this great discovery I have questioned several people on the subject, and when I ask "What nationality was Calvin?" they answer rather hesitatingly, "Scotch, wasn't he?"

I wonder what he would think if he could come to life and take a stroll around the present-day Geneva, especially on a Sunday. It would certainly horrify him beyond words to see what the descendants of the Calvinists of his time were doing. Picture shows all packed, excursion boats crowded, parks and streets full of gay promenaders—and the churches?—the churches all more or less empty.

I think he would die from the shock.

In the History of Geneva which I am reading there is a list of "punishments" meted out to offenders in Geneva in the time of Calvin. Here are a few of them:

"One man was punished for wearing baggy knickerbockers on the street; a second for offering his snuff-box to a friend during the sermon; a third for talking business to his neighbor as he was coming out of church; a fourth for calling his cow by the scriptural name of Rebecca."

There was not much chance for the full play of individuality in Geneva at that period. A man couldn't even swear without paying a fine. For the first offence "he had to kiss the ground; for the second, to kiss the ground and pay three shillings; for the third, three score shillings and three days in prison with bread and water; for the fourth time, to

be deprived and banished the town for a year and a day."

There must have been a great many bankrupts and exiles in consequence of this rigid law.

Geneva of to-day is a beautiful and attractive city—but it has one disagreeable drawback, which, I suppose, existed also in the time of Calvin. This drawback is the "bise" (north wind). When the bise blows, out-door life has no charms; arrows of ice and whirlwinds of dust greet you at every corner, and reduce you to such a state of nervous irritability that you are not fit to live with. But, thank goodness, the bise doesn't blow all the time. If it did, our stay here would be short.

The city is so crowded that we found it difficult to get satisfactory rooms. There are so many schools here that the place is full of students. They come here from all countries, as Geneva is noted for its educational advantages. There is a big university attended by about two thousand students. Half of them are foreigners, and the majority of the foreigners are Russians.

THE RED CROSS AGENCY FOR PRISONERS OF WAR.

A few days ago we visited the Agency for Prisoners of War. The special branch of the Red Cross in Geneva is located in the Rath Museum, a detached two-story building used for temporary art exhibitions. The Agency occupies the entire building. In fact, some of the work has to be done outside, as the Museum is not large enough to accommodate the hundreds of people required to attend to the enormous correspondence connected with the work of this department. We knew a good deal about the wonderful work carried on by this Agency, but it was most interesting to see the place where it was actually being done, and the people who were doing it. We were conducted through the building by the Director—a courteous, soft-voiced gentleman, who spoke English fluently.

Just inside the entrance door there is a long row of black-bound books, alphabetically arranged, containing the names of all the prisoners of war, and any details known concerning them. Over two million names are recorded there. Two million! Just think of it! It gave me the shivers just to look at that tragic row of books and think how much misery and suffering and heartache and heartbreak was associated with each name on the list.

The Director told us that the Geneva Agency maintains direct correspondence with the military hospitals, prisons, and camps of prisoners of war in Germany, France, Belgium, and England. Official reports are received constantly from all these belligerents, giving the names of new prisoners, state of their health, and other information; also reports as to death and place of burial of prisoners. These reports are systematically recorded in books, and an index card is made out for each prisoner, by means of which all the information on file in regard to any prisoner can be instantly referred to.

He also told us a great many other things about the way the Agency was managed, but while he was pouring information about card indexes and things into Uncle Ned's ears, I was lagging behind staring around at the people who were at work in the rooms. They were of all sorts and conditions, judging by their appearance. There were pretty girls of seventeen with wax-doll complexions and marcelled tresses, and sallow, elderly dames, with wrinkled faces and scant locks; there were young men, middle-aged men, and bald-headed gray-beards of seventy (or thereabouts). And there were quite a number of Swiss

soldiers in uniform, fine-looking chaps they were, too.

"German-Swiss soldiers," explained the Director, "loaned to us by the Swiss Government to help us with the German correspondence—at no expense to us."

The amount of correspondence handled by the Agency is something fabulous. "At one time," said the Director, "we were receiving over thirty thousand letters a day."

"Thirty thousand!" I gasped.

"Yes," said he, "thirty thousand. We were simply swamped with work. Had to work day and night. But, just at present, the work is comparatively light, only about three thousand letters a day."

"And how many people have you working for you?" asked Aunt Julia, or, perhaps it was Uncle Ned. Anyway, it was one of them.

"Over twelve hundred."

"Really! And is it true that they receive no pay for their services?"

"Quite true. All the work is gratuitous—all except what is done by the stenographers. There are eighty of them, and they are all paid."

"And do these volunteer assistants give all their time to it? Do they come here every day?"

"They are expected to work five hours a day, and not less than three days a week. Unless they can give that much time to it we cannot accept their services."

"Are all these people who are doing the work here—are they of Swiss nationality?"

"Not quite all," said the Director, "but they are residents of Geneva. We have some people of other nationalities helping us. That lady over in the corner is an American."

The work of the Agency is done in large rooms, subdivided into sections, each section being devoted to some special branch of the business. The correspondence relating to the Germans is carried on in the upper floor of the Museum; while that relating to the Allies is done on the lower floor. The bulk of the work consists in receiving and answering inquiries from the prisoners of war, and in forwarding to the prisoners money, clothing, food, etc., sent for that purpose to the Red Cross by friends of the prisoners; also in forwarding letters to and from the prisoners.

"This is where the work relating to the civil internees is attended to," said the Director, pointing to a room we were passing, where several men were engaged in sorting a mountain of letters; "and this," pointing to a long desk, "is where the death notices are made out."

There were two young men sitting at that desk, one of them handsome and well dressed, the other distressed-looking and very shabby. The well-dressed one seemed to be jotting down details supplied by the shabby young man, who was weeping and mopping his eyes with a mussy handkerchief.

At one desk we stopped to look at some photographs of the various camps where the prisoners of war are interned. These photographs, the Director said, were to be reproduced on postal cards and sent to the inquiring relatives of the prisoners.

"What a marvellous work this Society is doing!" said Aunt Julia, as we reached the door to go out.

The Director bowed an appreciative acknowledgement.

The last thing I saw before we went out was that awful row of black books containing the names of the two million unhappy prisoners of war.

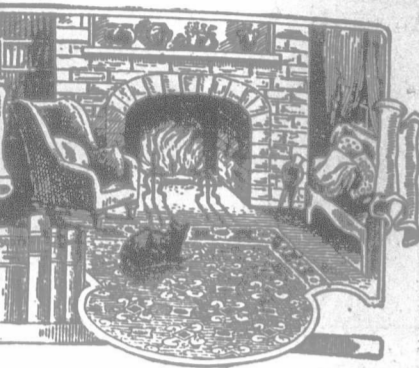

soldiers in uniform, fine-looking chaps they were, too.

"German-Swiss soldiers," explained the Director, "loaned to us by the Swiss Government to help us with the German correspondence—at no expense to us."

The amount of correspondence handled by the Agency is something fabulous. "At one time," said the Director, "we were receiving over thirty thousand letters a day."

"Thirty thousand!" I gasped.

"Yes," said he, "thirty thousand. We were simply swamped with work. Had to work day and night. But, just at present, the work is comparatively light, only about three thousand letters a day."

"And how many people have you working for you?" asked Aunt Julia, or, perhaps it was Uncle Ned. Anyway, it was one of them.

"Over twelve hundred."

"Really! And is it true that they receive no pay for their services?"

"Quite true. All the work is gratuitous—all except what is done by the stenographers. There are eighty of them, and they are all paid."

And do these volunteer assistants give all their time to it? Do they come here every day?"

"They are expected to work five hours a day, and not less than three days a week. Unless they can give that much time to it we cannot accept their services."

"Are all these people who are doing the work here—are they of Swiss nationality?"

"Not quite all," said the Director, "but they are residents of Geneva. We have some people of other nationalities helping us. That lady over in the corner is an American."

The work of the Agency is done in large rooms, subdivided into sections, each section being devoted to some special branch of the business. The correspondence relating to the Germans is carried on in the upper floor of the museum; while that relating to the Allies is done on the lower floor. The bulk of the work consists in receiving and answering inquiries from the prisoners of war, and in forwarding to the prisoners money, clothing, food, etc., sent for that purpose to the Red Cross by friends of the prisoners; also in forwarding letters and from the prisoners.

"This is where the work relating to the civil internees is attended to," said the Director, pointing to a room where several men were engaged sorting a mountain of letters; "and this," pointing to a long desk, "is where the death notices are made out."

There were two young men sitting at a desk, one of them handsome and well dressed, the other distressed-looking and very shabby. The well-dressed one seemed to be jotting down details supplied by the shabby young man, who was scripping and mopping his eyes with a lacy handkerchief.

At one desk we stopped to look at the photographs of the various camps where the prisoners of war are interned. These photographs, the Director said, are to be reproduced on postal cards and sent to the inquiring relatives of the prisoners."

What a marvellous work this Society is doing!" said Aunt Julia, as we checked the door to go out.

The Director bowed an appreciative acknowledgement.

The last thing I saw before we went was that awful row of black books containing the names of the two million wretched prisoners of war.

Among the Flower-Lovers.

On the second of November I set out for the Place of the Flower-lovers, and on the way thither, looking from the window of the train as it whizzed past the heaps of ashes and coal, and flatcars, and ugly commercial sheds that usually disfigure the approaches of our towns and cities, found my attention riveted by a spot that fascinated by its ugliness, as one looks at a snake in a cage, you know. The "spot" was a house, once rough-cast, I think, but now blackened by smoke and stained by weather. Upon two sides it was shut in by high banks of black composite created by the curving railway for trucks for which they had been built; upon the other thundered by the trains of three or four more important railways laid parallel on a field of black cinder. There was not a tree near; not a plant, nor a blade of grass. All the view from two sides was stopped by grimy banks, but a few rods from the walls, yet at the windows there were sooty curtains, lace at that, evidently someone was living there.

The contrast between the thoughts provoked by this place and those that flew to the surface whenever one's mind ran forward to the Place of the Flower-lovers was great. One could not help wondering why, in this Canada of pine air and big spaces, anyone should have to live in such a pit of ugliness and gloom, and—wandering on—why anyone anywhere in this great free land should not have something of natural beauty in his or her life, plants to love and look at,—plants and trees and vines, without which no home, however happy and satisfactory otherwise, can be absolutely ideal.

The Place of the Flower-lovers this year was the Railway Committee Room in the Parliament Buildings, Toronto. And now perhaps it is time to tell that the occasion was the Annual Convention of the Horticultural Association of Ontario. People sheer off from plain "convention" headings, somehow, pass over reports of them as of interest only to those who happened to "be there," and yet such reports should be of interest to everyone everywhere, else why publish them at all except in the Association blue-books?—Of interest, and inspiration, too, for surely when a report leads to the forming of a new branch of any useful organization, it has not been wasted.

I certainly think there should be a branch of the Horticultural Association in every community in Canada. Were this accomplished, it would not be long until our country would be beautiful as England herself, land of beautiful gardens, and surely that is something worth working for.—I say nothing of the pleasure connected with all the work of horticulture, flower-growing, vegetable-growing, fruit-growing. As Prof. Crow of the O. A. C. remarked, this gathering was the first which he had attended where people were "in the business for the pure love of it."

The Railway Committee Room is flanked upon one side by two immense single-paned windows, which overlook the beautiful Parliament grounds and University campus. Although the 3rd of November, a tree directly in the foreground carried all its leaves; not far away, stately gleamed above green grass; the whole a fitting setting, surely, for the deliberations and rejoicings of the Flower-lovers, or, at least, would have been absolutely so except for the fact that away out there on the University campus, bodies of young men were continuously engaged in military drill, marching and countermarching, forming fours and running in squads. It is hard indeed to get away from the shadow of war in these calamitous days. The Convention was opened by a very short address from the President, Mr. J. H. Bennett, of Barrie, who touched upon the war, speaking in admiration of the peasants in Europe who have continued to plow and sow and cultivate right up to the firing line. An odd effect of the war upon flower-growing, he noted, has been that bulbs from Holland can to-day be bought for less money than usual.

WORK DONE DURING THE YEAR.

The report of the Superintendent, Dr. J. Lockie Wilson, is always listened to with interest by the delegates, of whom this year there were about 150. Notwithstanding the interference due to the War, he was pleased to report a successful year, and the formation of seven new societies, at Cayuga, Chatham, Dundas, Essex, Milton, Port Credit, and Richmond Hill, these bringing the total of the societies in the Province to 79, with a membership of 14,000. As soon as conditions become normal again, it is hoped that the number of lecturers sent out to these societies may be increased.

rich Society placed several books on gardening in the public library, among them Bailey's Cyclopaedia of Horticulture. At Guelph a vegetable garden competition, as well as one for flower-gardens, was held. In Hanover, window boxes were placed in windows of Town Hall and Library, and a silver cup was offered for the rural school which will succeed in having the best bulb garden for three years. Midland branch placed flower-beds at the Hospital and Town Hall. Orangeville and other places donated money received at flower shows to Red Cross fund. In Ottawa, \$211 was expended in prizes for Front Gardens,

nothing worth while is easy, and we must be willing to put thought as well as work on our gardens.

In planning, the house must be considered, and the grounds made a suitable setting for it. Scattered, haphazard planting must be avoided. The best effects are obtained by mass effects, and as a rule it is best to plant fewer kinds but greater masses. The speaker quoted approvingly from one of Prof. Bailey's anathemas against iron bull-dogs, white-washed stones, etc., on lawns.

Have the residence as the central idea, with a fine greensward extending from it, and provide for good vistas. Mass the planting of trees and shrubs at the sides and in the rear. Have flowers in the borders or in a place by themselves. "The easiest way to spoil a good lawn is to put a flower-bed in it." Don't descend to trivialities. Roses should be planted alone. Annuals are very useful for first-year effects.

Study to have a succession of flowers, and mass them as much as possible in long "drifts," the one overlapping the other, for long borders. Find out the beauty of colonies of flowers, from 50 to 200 of the same plant. Have you ever seen 200 Yucca filamentosa in one clump? Have you ever seen 200 of anything?

In all home planting, remember that the effect does not depend upon display, but upon the adaptation of the garden to the spirit that is within, something that is one's own, one's home.

In passing, Miss Yates paid tribute to Miss Jekyll's gardening books, and her words were strongly endorsed by Mr. R. B. Whyte, of Ottawa, one of the most distinguished horticulturists and flower-lovers in the Dominion.

In the discussion which followed, Prof. Hutt spoke of the development of gardens. He had visited 700 during the summer, and had found that almost invariably people begin with small collections through the love of flowers, and pass on to problems of arrangement. He, too, warned against formal planting where it does not fit. He told of one little garden, "a miniature paradise," at 90 Dominion St., Toronto, in which informal planting had been used with excellent effect.

Dr. Wilson, in introducing Miss Blacklock, of Meadowvale, told of the beauty of her garden with its "flashes of bloom," and spoke in particular of the borders of her driveway, very artistic, in which hardy wild English asters have been used to great advantage. Prof. Crow, of the O. A. C., added his tribute to Miss Blacklock's garden. He had brought down his whole class to see it. For his own part, his favorite work with flowers is hybridizing, which he recommended to the Convention as the "crowning delight" of horticulture. Rev. Mr. Tebb, of Hamilton, told of two schoolboys there who have been awarded diplomas for work in hybridizing. He recommended visiting gardens as a great inspiration in floriculture. Dr. Bennett, of St. Thomas, when asked how St. Thomas had got its 1,400 members, said, "We get after them." He considered that a man who hasn't public spirit enough to give \$1.00 a year for such a good cause isn't a worthy citizen. Mr. Ogilvie said that the horticulturists must lead. He had noted that where one home began a beautiful garden, most of the homes around followed. Mr. R. B. Whyte, of Ottawa, originator of the "Herbert" raspberry, which promises to supplant all other varieties in Canada, also spoke of the delightful "excitement" there is in seeing new kinds developed. He is now experimenting with seedling gooseberries in the hope of producing a large species which will withstand mildew. At present he has 120 varieties.

DISCUSSION ON REPORTS.

This discussion was opened by Mr. R. B. Whyte, Ottawa, who was most enthusiastic in regard to school fairs as a means of educating the young. He had "never spent so delightful a day in his life" as at a fair instituted by one of the District Representatives near Ottawa. The exhibits had been remarkable, especially those of Bantam corn and asters. He recommended strongly that the work of the District Representatives (of Agriculture) be encouraged.

His remarks brought out enthusiastic comments from Mr. Dockray, of Toronto;

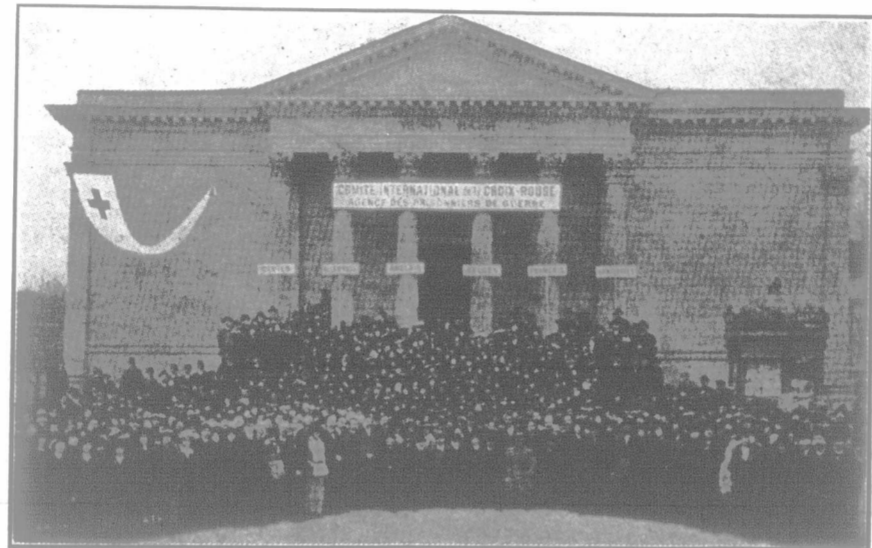

The Rath Museum, Geneva, Switzerland.

Showing the 1,200 unpaid assistants who are doing the work of the Red Cross Agency for Prisoners of War.

He praised highly the work done in school-gardening and the cultivation of vacant lots, and the beautifying of many towns, cities and villages through the work of the various branches, then closed by giving a synopsis of the reports sent in from these branches. Among many features reported we note these in particular: A Sweet Pea Show held in Barrie. Distribution of flower seeds and bulbs to school children by societies. Holding of general flower shows, and children's flower shows. Holding of garden competitions. A "Bluebird Bazaar," held at Carleton Place in March, at which the school children showed birdhouses made by them, also drawings of birds and flowers, bread, cake, candy, etc., contributed by the

Rear Gardens, and Window Boxes. In Perth, co-operative spraying of fruits was successfully undertaken. In St. Thomas, 110,000 bulbs were imported for members, and the beautifying of the whole city is being undertaken. Many flowers were sold for Red Cross funds, also flowers were sent to the sick and to churches. St. Thomas has a very flourishing society. Similar results are reported from Sandwich and Walkerville. Westboro offers a cup for the best kitchen garden. Windsor supplied the Home of the Friendless with flowers, and established a children's playground.

INFORMAL PLANTING OF HOME GROUNDS.

In a very delightful paper on home



Red Cross Assistants.

At work in one of the rooms in the Rath Museum, Geneva, Switzerland.

girls. Gladiolus bulbs were given as premiums, and the proceeds of the Bazaar, \$422.90, with a large bale of clothes, were forwarded to the Belgian children. As a result of the venture, about 150 bird-houses are now scattered throughout the town, and the neighboring villages have also taken up the idea of bird protection. Maple trees set out in fair grounds at Chesterville. Sale of cut flowers at Flower Show at Clinton netted \$22 for the Patriotic Society. Planting of flower-beds in parks in many places. Distribution of shrubs, bulbs, etc., to members in many places. Gode-

grounds, Miss Yates, of Port Credit, strongly advised natural rather than formal planting for the average home. Italian, Japanese and Dutch gardens, have a place in extensive and elaborate grounds, but wherever used they should be an adjunct, not a main part of the planting; they are not a part of the ordinary landscape.

Gardens may be divided into two classes, those with an ideal and those without. Every garden should have an ideal. For inspiration we should turn to the wild whose charm is at once the delight and distress of gardeners. But

Mrs. Cadwell, of Windsor, and others. It was recommended that seeds be sold to children at one cent per package, as they value things they buy more than those that are given them. A good plan is to buy seed by the pound and measure it out by the thimbleful. Rev. Mr. Scott, of Perth, embraced the occasion to recommend the spread of Bluebird Bazaars such as that held at Carleton Place, and Prof. Crow, of the O. A. C., Guelph, said that he would be glad to give help regarding the construction of bird-houses to those who appealed to him.

THE BEAUTIFICATION OF COUNTRY HIGHWAYS AND RURAL IMPROVEMENT.

R. A. Penhale, St. Thomas, spoke on this subject. In improving rural highways, an eye must be kept to accomplishing the best results with a minimum of labor. He advised having the sides levelled into a nice boulevard, which could be easily cut with a mowing-machine frequently enough to keep down weeds and weed seeds. Along these, trees should be planted. All "dumping" along roadsides should be strictly forbidden. Trees should be planted along all roadsides, and underdrains put in instead of deep ditches, which are often so dangerous. . . In beautifying country homes, a minimum of labor must also be kept in view.

ROSE GROWING.

Mr. P. H. Mitchell gave a paper very valuable to rose enthusiasts. There are already thousands of varieties of roses, and every year about fifty new ones make their debut, but many of these, after testing, return to oblivion. His first experiments were with the Richmond—a very perfect, long-blooming rose, whose rich scarlet he has seen encased in a sheath of ice in November—and hybrid-perpetuals. His experience has led him to think that every good rose can be grown in Canada with protection. The protection is given not so much against cold as to prevent thawings and freezings, which do the damage. Tea-roses can be readily grown thus, as well as the hybrid-teas, which are more vigorous. Mr. Mitchell spoke of many varieties, from dwarf baby ramblers to climbers, commenting on the marvellous beauty of coloring and longevity of bloom which have been achieved and put on the market from the various experimental stations, especially those at Belfast, Ireland, and at points in England and France. He concluded by giving out a list of "best" roses, from which the following has been condensed:

White.—"Frau Karl Druschki," a dwarf bush rose, with three buds at end of stems.

Blush.—"Prince de Bulgarie."

Yellow and Orange.—"Arthur Goodwin," "Sunburst," "Soleil d'Or."

Shaded Orange.—"Irish Elegance," which had given him the most pleasure of all, an orange-scarlet, very decorative one of first to bloom, and blooming until November. . . "Joseph Hill," very fine; pale pink, suffused with yellow; leaves resembling those of holly.

Crimson.—"George Dickson," very perfect; velvety black-crimson; of great size; leaves large, thick, and leathery. . . "Richmond," very satisfactory for a small garden; fragrant, and always in bloom.

HIGH ROSES :—

White.—"Una" and "Nova Zembla," a Rugosa rose.

Pale Yellow.—"Gustav Regis."

Yellow, multiflora.—"Danas."

Copper.—"Lady Penzance"; "Conrad Meyer," 6 to 8 feet; very fragrant; many flowers; pinkish.

Pink.—"Zephyrine Drouhin"; thornless; fragrant; very free from pests.

Dark Rose.—"Rugosa."

Crimson-Scarlet.—"Gruss and Teplitz."

Crimson.—"J. B. Clark."

CLIMBING ROSES :—

White.—"Climbing Frau Karl Druschki."

Blush.—"Alleric Barbier."

Yellow.—"Dorothy Perkins."

Pink.—"Climbing Caroline Testout";

"Tausendschon"; Multiflora.

Crimson.—"American Pillar"; "Crimson Rambler."

DWARF POLYANTHA :—

Crimson.—"Jessie."

Copper.—"Leonie Lamesch."

MOSS ROSES :—

White.—"Comtesse de Murinais."

Rose.—"Common Moss."

In the discussion that followed, Dr. Bennett remarked that the hybrid-teas are as easy to grow as lilacs, and almost as hardy. They need to be killed up 8 or 10 inches in fall. He recommended the "Julia." . . Mr. Hartry, Seaford, favored the "J. B. Clarke," and said that it must not be cut back. In winter, lay it down and cover with leaves and straw litter. He liked "Philadelphia Rambler" and "Excelsior" better than "Crimson Rambler," and had found them less likely to mildew. . . In reply to a question as to whether there is any remedy for black spot, Mr. F. E. Buck, of the Central Experimental Farm, Ottawa, said that lead arsenate is good, although it spoils the appearance of the green leaves by giving them a white appearance. Copper carbonate solution applied once a week is effective except in rainy weather. . . Mr. Hunt, of the O. A. C., had found lime-sulphur spray good, applied as for fruit trees, but diluted about 50 per cent. All leaves that fall should be burned, and the ground should be sprinkled with lime spring and fall.

HORTICULTURE IN THE NORTH LAND.

Mrs. Lorne McDougall, of Haileybury, gave a very delightful paper on the above subject, telling about the splendid growth in that land where the sun rises at 8, and daylight lasts until 10 p. m. in June and July. Gardening operations there must be "conducted on the run," she said, and in order to expedite them, fall digging and planting are advisable, also fall sowing of seeds of plants that self-sow, such as nicotine and candytuft. Hotbed plants must be well hardened off in a cold frame before setting out in spring, and a high fence or wall of evergreen trees to north and west is an advantage.

Annuals thrive well in the North. In her long border, 110 feet long, she had this year, among others, sunflowers, nicotine, early cosmos, antirrhinums, salpiglossis, schizanthus, gladioli, phlox drummondii, ageratum, stocks, asters, mignonette, and sweet alyssum. Zinnias do well in sunny, protected places, and marigolds bloom riotously. She had dahlias as large as a dessert plate, and recommended especially the "cactus" and "peony" varieties. For sweet peas, good results are obtained by starting the seed in pots or hotbed, removing to cold frame, then to the open. In one long border in Haileybury, a fine effect has been obtained by planting them in rows across the border and training on netting frames.

Hardy perennials and bulbs, such as iris, tulips, daffodils, Iceland poppies, columbine, pyrethrum, Canterbury bells, Shasta daisies, delphiniums, and Sweet William, do well with slight winter coverings to protect against the hot spring sun.

Vegetables also do well in the North, where she had seen extra early peas grow 10 to 11 feet in height. She had had great success with "The Alderman" pea, also with "American Cabbage" and "English Cos" lettuce. "Golden Bantam" corn, celery (about New Liskeard) and fall strawberries do well.

When Mrs. McDougall concluded, Mr. Whorley, of Haileybury, exhibited products of the North land, wheat, a turnip weighing 18½ lbs., carrots, onions, and a cluster of strawberries picked in November.

NEW AND UNCOMMON PLANTS.

Mr. Hunt, of the O. A. C., Guelph, gave a paper on new and uncommon flowers which will be reproduced in full at a later date for the benefit of people who like to try novelties. Among others he recommended: pot marigolds, hyacinth-flowered candytuft, "Starlight" sunflower, African daisies, Escholtzia Thorburnii (a bronze-crimson California poppy), double cornflowers, red sunflowers, rose petunia, ever-blooming Sweet William, gas plant, hardy chrysanthemums, Darwin and Rembrandt tulips, alyssum prostratum, Michaelmas daisies, blue spiraea, mallow poppy, scabiosa Japonica, and silene shafta. He remarked that he had used the flowers of the artichoke for decoration at a late fall function, and with excellent success. . . He saw indications that bulb-growing commercially may be carried on in this country with profit.

A PLEASANT EVENING.

In the evening an excellent illustrated lecture on "Town Planning from a Horticultural Standpoint," was given by Mr. Thos. Adams, of the Conservation Commission, Ottawa. Mr. Adams holds that the work of "planning" must be extended to the rural districts if Canada is to be the country that she may be; rural districts must be made more beautiful, and rural life more interesting. Nor does the question stop with that. It includes problems of industry and transportation,—good roads, and the living conditions of the people. There is a very intimate connection between homes and gardens. People everywhere should be in close contact with Mother Nature.

Recreation and education also come within the scope of horticulture. The school play-ground is an important factor; we need to cultivate the love of beauty in children.

We have a magnificent country, but we

are not making the best of it. This must be remedied. . . Later in the Convention Mr. Adams told of a "Civic Improvement League" for the whole of Canada which is being formed in Ottawa, and suggested that a delegate be sent from the Horticultural Association to the meeting to be held in Ottawa. He said that the aim is to have branches of this League in every town, and so make the organization one of the biggest in this country. He was good enough to give "The Farmer's Advocate" representative a bulletin issued in connection with his department. Of this, use will be made—so far as it touches upon rural advancement—in future issues of this journal.

OFFICERS FOR NEXT YEAR.

The following list of officers for 1916, the result of the election on Nov. 11th, is given, so that rural communities which wish to come in touch with the Horticultural Association may do so:

President—Rev. G. W. Tebbs, Hamilton.

First Vice-President—Dr. F. E. Bennett, St. Thomas.

Second Vice-President—Prof. Crow, O. A. C., Guelph.

Secretary—Dr. J. Lockie Wilson, Parliament Buildings, Toronto.

Treasurer—C. A. Hesson, St. Catharines.

Directors :—

District No. 1—Rev. A. H. Scott, Perth.

District No. 2—H. J. Clarke, Belleville.

District No. 3—R. Whorley, Haileybury.

District No. 4—T. D. Dockray, Toronto.

District No. 5—Jas. Ogilvie, Hamilton.

District No. 6—Wm. Hartry, Seaford.

District No. 7—R. W. Brooks, Brantford.

District No. 8—Dr. J. A. Bothwell, Stratford.

District No. 9—H. A. Gignac, Sandwich.

Honorary Director—J. H. Bennett, Barrie.

Auditors—Mrs. R. B. Potts, Hamilton; Miss Yates, Port Credit.

Representative to Canadian National Exhibition—W. B. Burgoyne, St. Catharines.

Representatives to American Civic Association, Washington—Rev. A. H. Scott, Perth; Dr. J. Lockie Wilson, Toronto; Mrs. Cadwell, Windsor.

Committee on Nomenclature—H. J. Moore; F. E. Buck, Central Experimental Farm, Ottawa; Miss Blacklock, Meadowvale; Wm. Hunt, O. A. C., Guelph; Prof. Macoun, Ottawa; Mr. Cavers, Oakville.

Mr. Robb, Vineland Station.

THE LILAC.

A revelation in regard to the lilac was an address given by Mr. John Dunbar, Assistant Superintendent of Parks.



A Fine Border.

are not making the best of it. This must be remedied. . . Later in the Convention Mr. Adams told of a "Civic Improvement League" for the whole of Canada which is being formed in Ottawa, and suggested that a delegate be sent from the Horticultural Association to the meeting to be held in Ottawa. He said that the aim is to have branches of this League in every town, and so make the organization one of the biggest in this country. He was good enough to give "The Farmer's Advocate" representative a bulletin issued in connection with his department. Of this, use will be made—so far as it touches upon rural advancement—in future issues of this journal.

OFFICERS FOR NEXT YEAR.

The following list of officers for 1916, the result of the election on Nov. 11th, is given, so that rural communities which wish to come in touch with the Horticultural Association may do so:
 President—Rev. G. W. Tebbs, Hamilton.
 First Vice-President—Dr. F. E. Bennett, St. Thomas.
 Second Vice-President—Prof. Crow, O. C., Guelph.
 Secretary—Dr. J. Lockie Wilson, Parliament Buildings, Toronto.
 Treasurer—C. A. Hesson, St. Catharines.

Directors:—

- District No. 1—Rev. A. H. Scott, Perth.
- District No. 2—H. J. Clarke, Belleville.
- District No. 3—R. Whorley, Haldenbury.
- District No. 4—T. D. Dockray, Toronto.
- District No. 5—Jas. Ogilvie, Hamilton.
- District No. 6—Wm. Hartry, Seaford.
- District No. 7—R. W. Brooks, Brantford.
- District No. 8—Dr. J. A. Bothwell, Stratford.
- District No. 9—H. A. Gignac, Sandwich.
- Honorary Director—J. H. Bennett, Toronto.
- Auditors—Mrs. R. B. Potts, Hamilton; Miss Yates, Port Credit.
- Representative to Canadian National Exhibition—W. B. Burgoyne, St. Catharines.
- Representatives to American Civic Association, Washington—Rev. A. H. Scott, Perth; Dr. J. Lockie Wilson, Toronto; Mrs. Cadwell, Windsor.
- Committee on Nomenclature—H. J. Gore, F. E. Buck, Central Experimental Farm, Ottawa; Miss Blacklock, Meadowdale; Wm. Hunt, O. A. C., Guelph; Prof. Macoun, Ottawa; Mr. Cavers, Oakville; Mr. Robb, Vineland Station.

THE LILAC.

A revelation in regard to the lilac was given by Mr. John Dunbar, Assistant Superintendent of Parks.



Rochester, N. Y. He began by telling of receiving a postal card from Tokio, Japan, in which the writer, a Japanese, referred to something he had read in one of the Reports issued by the Ontario Horticultural Association. He thought this a great tribute to the wide-spread influence of the organization. Passing on, he told of the 300 species of lilac growing at Rochester, and gave interesting information in regard to the "origin" of the lilac—its native places chiefly in the mountains of Bulgaria and in various parts of China. There is no species indigenous to America.

The lilac, however, has been greatly developed during the last forty years in the countries of Europe, especially in the Lemoine grounds in France, and in grounds of the United States, notably New York and Rochester. It was introduced into Great Britain in 1597.

There are now many blue and red lilacs, as well as purple and white; double-flowered varieties; tall and dwarf. In Rochester parks they had experimented with 800 species. Nearly all of the best varieties have come from crosses with the common lilac, and much is due to the discovery of several new kinds in China by the famous botanical explorer, Dr. E. H. Wilson.

Now, by having a variety, including the "Persian" lilacs, a long succession of bloom can be obtained. He recommended as a novelty, "Syringa reflexa," with curving panicles—"no other like it at all"—and "Syringa Japonica," from Japan, which blooms well into July. "Syringa oblata" is one of the earliest bloomers, and has very handsome foliage, which turns to a deep claret-red in fall.

Lilacs may be propagated: (1) By seed (sown as soon as ripe). (2) By green cuttings taken the first or second week in June and started in sand in a hotbed, shaded by cotton and kept damp. (3) By grafting, especially on roots of California privet, in the first week of February, in flats in a greenhouse. These are very good. (4) By layering—a method easy, but needing patience.

Among good varieties recommended were:

- Single flowered.—(Red)—"Danton," "Cavour," "Pasteur," "Milton," "Reaumur," "Congo," "Uncle Tom." (Blue)—"Gilbert," "Bleuatre." (Pink)—"Macrostacha." (White)—"Virginalis," "Princess Alexandra."
- Double.—(Blue)—"Victor Lemoine." (White)—"Madame Lemoine," "Dame Blanche." (Pink)—"Waldeck Rousseau."

In the ensuing discussion Mr. Cavers spoke of three noted collections of lilacs in America: At the Arnold Arboretum, Boston; "Highland Park," Rochester, N. Y., and at the Central Experimental Farm, Ottawa. . . It was suggested that "Highland Park" be one of the points to which Horticulturists' excursions be run. . . Prof. Macoun, of Ottawa, gave an invitation to those who wished to see the collection there (also a prospective excursion point). He said good success had been attained there with Lemoine's hybrids, also that lilacs are now being grown in Canada as far north as the Peace River District, 1,000 miles north of Toronto. Care should be taken to plant the tender kinds very deep.

GREETINGS FROM THE U. S.

Mr. Lemon, a native Canadian, represented the American Civic Association, and brought greetings. In the work, he said, remember that "praise will do more than censure." Write to those who have done well with their lawns and gardens, and have an exhibit of "before and after" photos.

In closing, he quoted the following, which, he said, "will sink into people who don't read Browning":

"Little beds of flowers,
 Little coats of paint,
 Make a pleasant cottage
 Out of one that aint."

BEST PAEONIES.

Mr. F. E. Buck, of the Central Experimental Farm, Ottawa, read the following list of best paeonies, compiled by Prof. Macoun:
 White.—"Duchess de Memours," "Le Cygne," "Marie Lemoine."
 White flecked with crimson, and flesh white.—"Avalanche," "Baroness Schroeder," "Couronne d'Or," "Festiva

Maxima," "Marie Jacquin," "Monsieur Dupont."

Pale Pink.—"Asa Gray," "Eugene Verdier," "Grandiflora" (Richardson's), "Mlle. Leonie Calot," "Marguerite Gerard."

Pink.—"Claire Dubois," "Livingstone," "Mme. Auguste Dessert," "Mme. Geissler," "Modeste Guerin," "Monsieur Jules Elle," "Therese."

Red.—"Felix Crousse."

Dark Red.—"Adolphe Rousseau," "Monsieur Martin Cahusac."

SOME VEGETABLE NOTES.

Prof. Macoun gave an interesting talk on a trip through California, and Mr. Geo. Baldwin followed with a talk on "Vacant Lot Gardening." As this applied chiefly to cities, it is passed over here, except for a few points useful everywhere, viz.: Nip off the tops of tomato plants after the fourth row of blooms has set. Celery—A good plan to plant four varieties in four close rows; the heads may be wrapped with paper. Onions—Clip the tips off before transplanting to secure better bulbs, and transplant very carefully, making a good hole first for each plant; guard against cramping the roots. Potatoes—Among good varieties are "Beauty of Hebron," "Rochester Rose," "Rose of the North," all standards. Economy in drills—

On the ridges piled up on each side of celery trenches plant radish and lettuce. Mr. Baldwin recommended highly a bulletin on gardening by S. C. Johnson, issued by the Department of Agriculture, a pamphlet which should be in the hands of every farmer.

So closed the Tenth Annual Convention of the Horticultural Association of Ontario, a session as pleasant as profitable. It is to be hoped that next year the rural communities of the Province will be more largely represented.—J.

Hope's Quiet Hour.

They That Be With Us.

When the servant of the man of God was risen early, and gone forth, behold, an host compassed the city both with horses and chariots. And his servant said unto him, Alas, my master! how shall we do? And he answered, Fear not: for they that be with us are more than they that be with them.—2 Kings vi: 15, 16.

Elisha's servant looked only at the visible host of horses and war-chariots which threatened the life of his master; but Elisha was fearless and untroubled, because he knew a body-guard of angels surrounded him. And Elisha prayed, and said, "LORD, I pray Thee, open his eyes, that he may see." His prayer was answered and the young man saw: "and, behold, the mountain was full of horses and chariots of fire round about Elisha."

The young man was afraid because he looked at the might of the enemy; Elisha was calm and brave because his eyes were on God. Like Moses—who forsook Egypt, not fearing the wrath of the King—he endured, as "seeing Him Who is invincible."

What of ourselves! We are often discouraged and cowardly, simply because we fail to realize the fact that "they that be with us are more than they that be with them." Possibly Elisha did not himself see, with his bodily eyes, the horses and chariots of fire which guarded him, but he knew they were there. It may be that his faith was too strong to need the outward, visible proof which was granted to the weaker faith of his servant. Miracles are not always an advantage nor a special privilege. Our Lord gave to St. Thomas the outward visible sign he had demanded, yet He gently rebuked the weakness of the faith

which required physical proof: "Because thou hast seen Me, thou hast believed: blessed are they that have not seen, and yet have believed." When I was a little girl I heard a sermon preached on that text, and I made up my mind to try and win that great blessedness.

If we only trust God's power and love when He is visibly making a way for us through the sea of difficulty, we are not really trusting Him at all. If a friend of yours is accused of an act of cruelty, and you refuse to believe in his goodness until you are given actual proof that the accusation is a slander, then you are showing that you have no faith in your friend.

We can hardly wonder that some men find it well-nigh impossible to believe in a loving, all-powerful God, when they see the helpless and the innocent trampled under foot. "How can God be loving and just and yet allow such misery to go on, such cruelty to remain unpunished?" they cry. Then they take refuge from the impossible thought of an unjust God in the other impossible idea of a universe which is self-created, self-sustained, and ungoverned by law. To know and love God is not necessarily to understand His ways. The child of a great surgeon may be puzzled when she hears that her father spends much of his time in amputating limbs and doing other terrible operations. She may not be able to understand or explain his apparent cruelty, but she knows he is not cruel. She rests safely in his arms, and is sure that his kindness to her expresses his nature, and that his severity towards his helpless patients is also caused by good-will. So, those who have learned to know that God's very Being is LOVE—that GOD IS LOVE—feel that it is the Great Reality, the one sure anchor that holds in this great storm. We can see the mighty host of the enemy, yet we know—as Elisha did—"they that be with us are more than they that be with them."

Does God, in these dark days, ever give outward proof of the presence of invisible allies? That is a question I cannot answer. In any case, the story of the "Angel Guard at Mons" is a reminder of the cheering words of the writer of the Epistle to the Hebrews. Speaking of the angels, he says: "Are they not all ministering spirits, sent forth to do service for the sake of them that shall inherit salvation? . . . God also bearing witness with them, both by signs and wonders."—Heb. i: 14; ii: 4, R. V.

Those of you who have friends at the front—which of us has not?—may be interested to hear some of the stories told of the supernatural aid which the soldiers claim to have received. Even if you do not believe that any supernatural vision of angels was really given, the story may help to strengthen your faith in the invisible legions of angels which our Lord Himself said He could summon to His side—and whose help He refused, saying: "How, then, shall the scriptures be fulfilled, that thus it must be?"

In the November Number of "The Canadian Nurse" several accounts are given of "The Angel Guard at Mons." One says that the small British party was nearly annihilated. "They were almost helpless when; to their amazement, the Germans stood like dazed men and never so much as touched their guns nor stirred till we had escaped by a cross road; a troop of angels came between us and the enemy." Another account: "While he (the officer) and his company were retreating after Mons, they heard the German cavalry tearing after them. They saw a place where they thought a stand might be made with sure hope of safety; but before they could reach it the German cavalry were upon them. They therefore turned round and faced the enemy, expecting nothing but instant death, when, to their wonder, they saw between them and the enemy a whole troop of angels. The German horses turned round terrified and regularly stampeded, the men tugging at their bridles." Another account: "Thirteen men in a quarry all saw the angels. . . Two colonels said they had seen them, one of whom until then had been an unbeliever. But all saw the salvation of this remnant of an army."

Do you think it would be a great help to our faith if God were to give us such visible proof of His help and protection? I don't feel sure that it would. We walk

by faith, not by sight. Faith tells us, even now, that our Lord is here with us, and that He is also with our friends in the trenches. If we could see Him, faith would instantly vanish in sight. St. Thomas had no faith in the Resurrection until he saw his living Master, and we are allowed the opportunity which he refused, of believing without seeing. The stories of the Angel Guard should remind us that David's words are true: "The angel of the LORD encampeth round about them that fear Him, and delivereth them." Again the Psalmist says of one who has sought a safe refuge in God: "He shall give His angels charge over thee, to keep thee in all thy ways."—Ps. xci: 11.

"Though destruction walk around us,
 Though the arrow past us fly,
 Angel-guards from Thee surround us,
 We are safe, if Thou art nigh."

Yes, One far greater than the angels is with us. If God be for us, what does it matter how strong our enemies may be? We may well echo Elisha's "Fear not!" if we are sure of God's Presence. The Invisible Friend stands between us and the visible foe.

"God is never so far off as even to be near:—
 He is within. Our spirit is the home
 He holds most dear.
 To think of Him as by our side is almost as untrue
 As to remove His throne beyond those
 skies of starry blue.
 So all the while I thought myself homeless,
 forlorn, and weary,
 Missing my joy, I walked the earth—
 myself God's sanctuary!"

DORA FARNOOMB.

Gifts For the Needy.

Since the first of January, readers of the Quiet Hour have sent \$73.00 to me "for the needy." This money has brought help—food, clothing, and other gifts—to thirty-one needy families. Some of these families have received help several times, and I have always personally investigated the cases and tried to spend faithfully the money entrusted to me.

My thanks again go out to those who have made me their almoner and given me the privilege of carrying their gifts to many discouraged strugglers.

DORA FARNOOMB (HOPE).

Come To Me, Little One.

Come to me, little one, drowsy and dear;
 Mother will spare me her darling awhile.
 I am so lonely when twilight is here!
 Lie on my bosom, and nestle, and smile.

I have no little one, dearie, like you,
 No little hand to hold close in the night,
 No one to dream of the lonely hours through,
 No one to wake for when God sends the light.

You are so sorry? Oh, bless you, my sweet!
 Dear little fingers that wipe off the tears!
 Little soft body and little white feet,
 How will they treat you—the terrible years?

Life is so fair to a baby like you;
 All things are wonderful under the sun,
 Rainbows are real, and all stories are true—
 Would they might be so when childhood is done!

Wide little eyes that are questioning so,
 Life is no stranger to you than to me,
 The secrets worth knowing I never shall know,
 The end of the rainbow I never shall see.

So, little drowsy one, nestle and sleep—
 Lullaby, baby, O lullaby-low!
 There always is peace in the dreams that are deep—
 Lullaby, little one, lullaby-low.
 —Elsa Barker, in "The Frozen Grail and Other Poems."



Stop!
need for
like this!

We want you to learn, as
hundreds of farmers learn every
fall, to abolish the drudgery of
barn-cleaning in winter time.

No heavy loads to lift, no hard
pushing, no paths to dig through
the snow, no slopping of manure
long passages and through the
yard. Manure taken out in big
loads of almost half a ton, easi-
ly and almost automatically.

Barn work becomes such a
pleasure that the boys are anxious
to do it. They will want the job.
And they will be able to do
the work four times quicker and
four times better than any man.

BT stands for Best Carrier

Because the BT Carrier runs
overhead it doesn't matter how
muddy the yard is, or even if it
is drifted full of snow. You can
keep the manure a good distance
from the barn in all kinds of
weather. The manure doesn't
need to be left close to the sides
and walls of the buildings, where
it will rot the boards, take paint
off implements and buggies, and
injure the health of the cows.

The wide-mouthed bucket is easy to
load without slopping over. It's water-
tight, and keeps every drop of liquid
manure until you reach the pile.

All these are important facts. But
you can't dwell on them here. You
ought to get our big, new illustrated
book about manure carriers and read
every word. 64 pages in it, and illus-
trated by fine photos that show just
how well the carrier works in the barn.

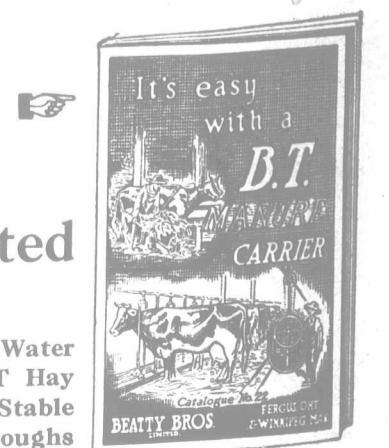

Stop! Put in a BT Manure Carrier right now!

Don't put off.
Now's the time to get your BT
Carrier put in. Hundreds of other
farmers are putting them in now.
Be ready for the winter work.
Be ready for the long, cold days
when the cows will have to stay
in the barn.

The winter's the time when
stable cleaning is the worst
drudgery. A BT Manure Car-
rier will save enough monoton-
ous, tedious work the very first
winter alone to pay its entire cost.

Remember that you will use it
every day of the week, as long as
the cows are in the barn. You
use it on Sundays as well as week
days, month after month. Even

if the hired man is away on Sun-
day, the cleaning is a snap and
you can do it yourself in a few
minutes.

If you like you can dump your
loads of manure directly into
wagon or spreader and haul to
the field. This saves liquid man-
ure, prevents fire fanging and
bleaching. There is only the one
handling of the manure. You
don't have the job of taking ma-
nure out of the yard in the busy
spring time.

No implement on your farm
can pay better than a BT Ma-
nure Carrier. When you have it
you'll never do without again.
But get it in now and be prepared.

BT stands for Best BT Manure Carrier

The first thing to do is to
send for our book.

There is important informa-
tion about the construction of
manure carriers that you ought
to have before you buy. You owe
it to yourself to investigate fully
before you buy.

Learn why the big BT Carrier
is so popular. Twice as many
BT Carriers are sold every fall
than all other makes combined.
There are good reasons for this,
and you should know them
thoroughly.

Let us tell you how the BT
Carrier is built so big and strong
that it will stand up to all the
hard work of stable cleaning
year after year.

We want to tell you about the
famous 1-beam track that is be-

ing sold to farmers all over this
continent. It was the first real
manure carrier track ever made.
The narrow, rounded edge does
not collect snow or ice in the barn
which might block the way so
you couldn't run the carrier out
to the pile. It can be bent round
for curves without heating, and
anyone can erect it in the barn.

Let us tell you about the hand-
wheel for raising and lowering
the carrier. Raises the loaded
bucket quickly, easily and with-
out noise. It's a clean handle to
use in pushing the carrier, so
your hands don't get soiled.

There are many other advantages
fully described and illustrated in the
new BT Book. Send for it to-day.

Simply fill out coupon, and we will
send a copy free by return mail.

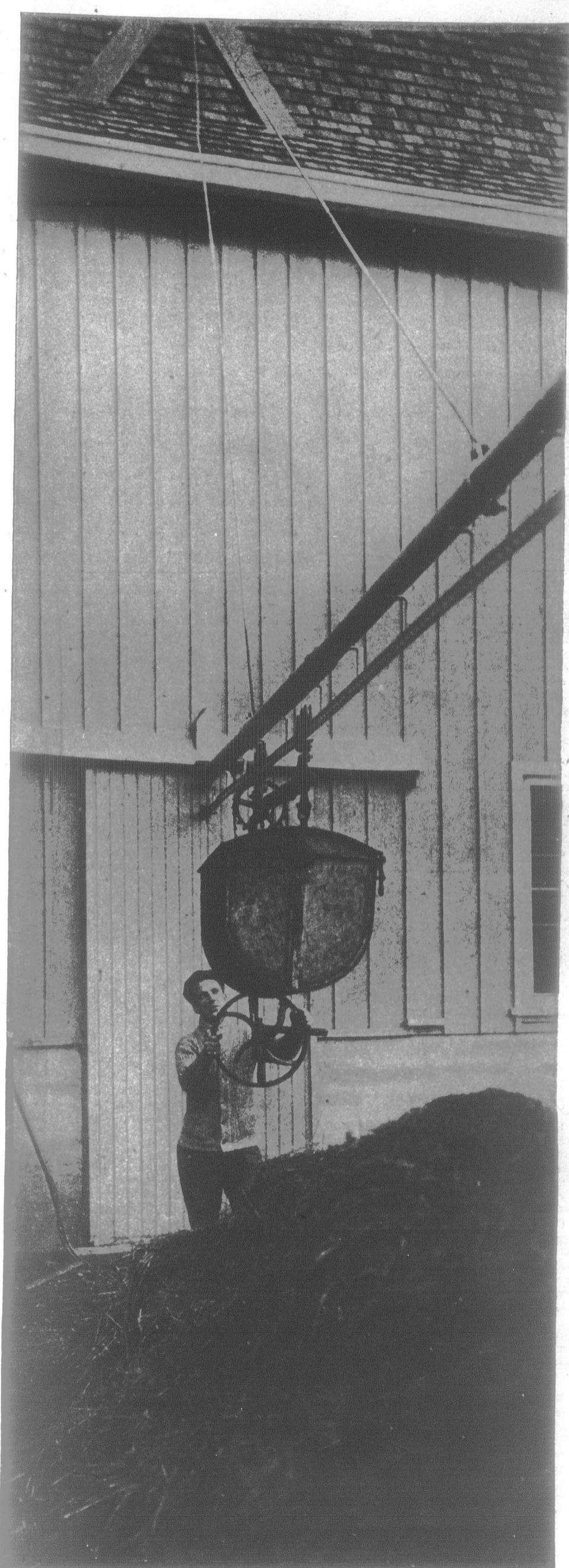

FREE BOOK COUPON
Beatty Bros., Limited
1981 Hill Street FERGUS, ONTARIO
Send me your new illustrated book about the Manure Carriers.
I keep.....cows. I am thinking of putting in an outfit about

Your Name.....
P.O..... Prov.....

The Beaver Circle

OUR SENIOR BEAVERS.

[For all pupils from Senior Third to Continuation Classes, inclusive.]

Horses' Heaven

By Anna M. Fielding.

"Oh, say there's a Heaven for horses, do please!"

Said a gentle child one day—
"With fields of oats in the waving breeze,
And stacks of new-mown hay."

"Where never are heavy loads, nor whips
To torture their patient sides;
And never a cruel bit for their lips,
Nor spur from him who rides."

"For a jeweled throne, a spacious stall,
In a stable large and clean;
Where they, no longer held in thrall,
May lead a life, serene."

"May the golden streets on which they tread,
Be soft to the weary feet;
Where buttercups with nodding head,
Gay dandelions greet."

"Their heavenly harp, sweet birds in the blue,
Trilling gaily as they pass;
Their halo, the sunlight filtering through
Shade-trees, and kissing the grass."

Funnies.

READY FOR THE CIRCUS.

Freddie—"Are you the trained nurse mama said was coming?"
Nurse—"Yes, dear; I'm the trained nurse."

Freddie—"Let's see some of your tricks, then!"—Seattle Star.

The self-made man was in a caustic mood. "These schools, ye know," he said, "they're no good. Don't give a boy no practical knowledge. See what I mean? Now, my son, he's supposed to be learning Greek, an' Latin, an' algebra. An' the other day I asked 'im to tell me the algebra for fried potatoes, an' 'e couldn't."

Senior Beavers' Letter Box.

Dear Puck and Beavers,—This is my second letter to your charming Circle. The first time I wrote to your Circle I did not get my letter in print, but I got my name in the "Honor Roll." I want to tell you about our School Fair. It was held at Tarbert church-ground. It was the Department of Agriculture that gave the seed and eggs in the spring. One of my brothers got eggs, and the other got potatoes, and both got a prize. I took bread, biscuits, and layer cake, and did not get a prize for bread. We had a fine time. There were six of us in a two-seated democrat.

I go to school almost every day. My teacher's name is Mr. Gowland. He has taught at our school fifteen years. I like reading the letters. We have taken "The Farmer's Advocate" for years. As my letter is getting long, I will close with a riddle.

Old Mother Twitchhead had but one eye, she had a long tail that she would let fly, and every time she went over a gap, she left a bit of her tail in the trap.

Wishing "The Advocate" every success,
I am yours truly,
STELLA NEWSON (age 11, Bk. IV).
R. R. 2, Arthur, Ont.

I wish some of the Beavers would write to me.

Dear Puck and Beavers,—This is my first letter to your Senior Beavers. I have been reading your letters in "The Farmer's Advocate," and I thought I would like to see my name in your paper, too. At Christmas I am going in Junior Fourth Class. I go to school every day, and I like it very well: there are about twenty-five pupils, and our teacher is a man. His name is Mr. Harris. I like him very well. I enjoy reading the Beavers' letters; they are just lovely to read in the evening. I hope the waste-paper basket is fed well when my letter passes by. Well, as my

letter is getting rather long, I will close with a few riddles.

What is it that goes up and down stairs on its head? Ans.—A needle.

If a church is on fire, why does the organ run the least possible chance of escape? Ans.—Because the engine cannot play upon it.

When is a lover like a tailor? Ans.—When he presses his suit.

Why do black sheep eat less than white? Ans.—Because there are fewer of them.

Why is your nose in the middle of your face? Ans.—Because it is the center. (Scenter.)

When is a fish like a bird? Ans.—When it takes a fly.

Why should a man never marry a woman named Ellen? Ans.—Because he would ring his own Nell (knell).

I will close now.

JOANNA ARTHUR.

(Age 12 years, Sr. III. Class.)

R. R. No. 1, Jasper, Ont.

Beaver Circle Notes.

Vera Myers (age 13), R. 2, Ancaster, Ont., wishes some of the Beavers to write to her. Her letter could not be published because written on both sides of the paper.

The Garden Competition results will be given next time.

Junior Beavers' Letter Box.

Dear Puck and Beavers,—My father has taken "The Farmer's Advocate" for a number of years, and I like reading the Beavers' letters. I have one little brother called Harold; he is seven years old. I go to school every day; my teacher's name is Miss Woodside.

I am going to tell you how I spent the Fall holidays. One of the ways was picking potatoes. I picked 236 baskets, and papa gave me a cent for every basket that I picked. I wish some of the Beavers of my age would write to me. I guess I will close now, hoping my letter will escape the w.-p. b.

JOHN EDGAR HOGG (age 9, Bk. II).
R. R. No. 4, Kensington, P. E. I.

Dear Puck and Beavers,—As I saw my first letter in print it gave me courage to write again. One day my father was to town and brought me home two gold fish. They are pretty. If you put your finger in the globe they will go to the bottom. They are small, but they look big. I will close with some riddles.

Why do you go to bed? Ans.—Because the bed won't come to you.
What is the lightest city in the world? Ans.—Cork.

What do the people do in Spain when it rains? Ans.—Let it rain.

What is the dirtiest thing in the kitchen? Ans.—A clock; because it never washes its hands or face.

Why is the letter "c" like the school teacher? Ans.—Because she makes classes out of lasses.

ANNIE MacLEAN (age 9, Jr. II).
Puslinch, Badenow, Ont.

Dear Puck and Beavers,—This is my first letter to your Circle. I have about half a mile to go to school. We have a nice schoolhouse, with a basement. In the evening when I come home from school I fetch the cows, calves and colts. I have a little pig which I feed with milk and middlings. I named it Winky. We had a School Fair. I grew corn and asters. I helped to dig potatoes. They are not a very good crop this year. I will close with a riddle.

How did the first pea come over the sea? Ans.—Round.

JAMES BAUMAN (age 9).
R. R. No. 1, Elmira, Ont.

Too Good.—"Well, Dinah, I hear you are married."

"Yassum," said the former cook, "I've done got me a man now."

"Is he a good provider?"

"Yassum. He's a mighty good provider, but I've powerful skeered he's gwine to git kitched at it."—Birmingham Age Herald.

A group of ice-houses went up in flames recently, and, according to a newspaper report, "twelve hundred tons of ice were reduced to ashes."

Into Action: A Psychological Study.

By W. Douglas Newton.

The Platoon-Commander came along the column, his head a little down and forward. He had a casual, doggy way, and Private 43237 wondered how he did it. The Platoon-Commander was so unperturbed that Private 43237 wondered whether officers of the Army received some particular spiritual grace with the King's commission that raised their level for emotion superior to that of privates. The Platoon-Commander made many small jokes. Private 43237 and the rest of the rank laughed at them as though they were marvellous jokes. It was curiously easy to laugh. But he hated laughing. He hated hearing people talk, or the necessity for talking himself. It seemed to get in the way. But he talked incessantly to the man who stood and said nothing beside him.

Private 43237 had already asked himself if he were afraid. He had already answered himself that he did not know. He had thought a lot about fear during the last nine months; he had an analytical turn of mind, and of all the fears he had imagined, none was like this tight-skinned, wild-blooded emotion. He knew that he would have to cast old notions of fear overboard. The old fear was rather dramatic. This was a sort of excitement boiling over. Was it fear? Or was it rather like going to the dentist?

He felt angry with an enormous number of things. The man on his left was fooling with his webbing. Private 43237 was feeling that the idiot ought to know he hated his doing that. A man several files away was being funny in a nasal voice. The voice pierced to Private 43237's marrow; it was like the sound of a baby crying and crying and never leaving off. He clenched his hands and stiffened his shoulders. He called to Heaven that the fool should stop. Also, Private 43237 could not remain still. He was always turning round, fidgeting, scraping his feet. The man behind him demanded in the name of Hades why he couldn't keep quiet. Private 43237 felt an uncontrollable passion at once. He felt that he ought to turn round and plunge his bayonet with a lifting motion into the bowels of the man who had thus insulted him. He shook all over with an almost irrepresible rage.

The column heaved, began to lift forward. Private 43237 could see the heads and the rifles of the men further forward beating and swinging as they got on the move. He saw it all with a piercing clarity. He had seen wind sweeping over a field of oats, and the movement of the ranks was exactly the same. The Company Officer called them to attention in a voice that was shrill, and Private 43237 tried to obey too quickly. Somehow his hands were thick and wooden. He fumbled and yawned, and his feet shuffled fuddledly. He knew he must be terribly conspicuous, glaringly clumsy. He waited for the curse of the Sergeant. The Sergeant said nothing.

The guns had been going steadily for hours, but now the sound they made was denser. Before the noise had been as the sound of great doors slamming in a muffled distance. Now the sound became enormous, and seemed to swing him with its beat. It was also curiously oppressive, like a thing of soft and vast weight upon his shoulders and brain. The roar of the terrible artillery plucked his entity from him. It was controlling him with a frantic and irresponsible motion. He felt that his soul had been caught into a whirlpool of noise, and was being flung and spun all-whither, in spite of his effort to check it and to be steady and even-keeled. He was clutching at and wrestling with his will, trying to force it to behave.

They had got off the road. They were down between the moist walls of the communication-trench, stumbling along in single file, falling over each other's heels. The gunnery was on top of them, hitting down into their skulls with terrible blows of sound. The sound seemed to surge and to wash about him, to lift him off his feet, to get into him and make him choke. It was as though he were fighting for life in a sea of clamor. The spray of the sea washed against him and all but submerged him.

The wild excitement that he had no-

ticed before seemed to be not only in him now, but about him. It was racing out of him at a frightful pace, and racing in again. It wasn't fear. No, it wasn't fear. It was the maddest and most disintegrating of nervous anarchies. His nerves appeared to be yelling at the top of their voices; to be elbowing their way out of his body. There was a sense of clamant energy. He wanted to get on, to get on with an almost crying urgency; that is why he stumbled so often over the heels of the man in front, and why the man cursed him. At the same time he knew if he went back, turned and went back, he would go with the same blind and frightful haste. Was this fear? He did not recognize it. It was courage and panic mixed up in a febrile and frantic boiling. They turned and twisted in the trench. Officers were calling to them in voices of supernatural calm, giving them trite orders as though they were marching past the saluting-base at home. The calmness of the officers was like cold water. It bit into a man; enabled him to hold his boiling soul down. Something within Private 43237 said: "Take a slower and steadier step. That'll calm you." He did so. The private behind him drove against his back, and the private behind yapped: "Git on. Git on. Git on. Git on, dam you!"

Private 43237 scowled at the private behind. The infernal ass had got nerves. A fool like that caused panics.

There was a slash of rifle-firing, abrupt and disturbing as the tearing of stout linen. Private 43237's heart jumped and screamed with it. There was yelling and firing before them, and away to the right; almost, it seemed, behind them. A machine-gun coughed, stuttered a little, then began to sew all sounds together with short, whirling bursts. There were the thick and guttural explosions of grenades.

Private 43237 put his hand on the moist wall of the trench, and he half turned. He wasn't afraid. No, it wasn't that. But he felt that someone ought to tell him what he ought to do. Someone ought to explain things to him. He felt extraordinarily hopeless and helpless. All reliance went from him for that moment. He did not even have the initiative to run. Yet he was hoping someone would run so that he could follow. Down the trench an officer with a brass voice was yelling for "supports." The man in front of him was already round the traverse. He jumped forward. He must keep up. The idiot behind him would think he was afraid. He wasn't afraid, of course, but that fool hadn't the quality of mind to understand.

They were out in a long trench, lined out. There were little ladders leaning against the wall, reaching to the top of the sand-bags. He found himself in front of one of these ladders. He would have liked to shift along to a space where there was no ladder, but the other men might notice that. He climbed the rungs solemnly and slowly. He only did it because other men, who watched him sidelong, also did it. There was an officer crouching at the top, his hand was out to hold them back. He was watching the plain warily. Private 43237 wished he could tear his eyes from the officer's hand.

Then the command. Private 43237 rose quickly to the top of the bags, and blenched. There was an enormous space before him. The place was hot and smoking with explosion. Away at an infinite distance there seemed to be a confusion that might be fighting. But that didn't matter. It was the plain. It was leaping and gushing with smoke, as though a volcano burnt beneath. It was also enormous. He must be seen at once if he got on to it. He would be horribly conspicuous. All the guns would fire at him at once. They wanted him to be the first man on the plain. He knew. They wanted to slip on to it and across while the enemy concentrated on him. It was a conspiracy. And the plain was so blank and enormous—save for the death in the smoke. He felt as though he were up on a tower and alone. Chilly and frigidly alone.

Then, good God! there was another man on the plain, another and another; they had come from the trench and were running forward. The ground was starting and smoking about them. But they

ed before seemed to be not only in
m now, but about him. It was racing
t of him at a frightful pace, and rac-
g in again. It wasn't fear. No, it
asn't fear. It was the maddest and
ost disintegrating of nervous anarchies.
s nerves appeared to be yelling at the
p of their voices: to be elbowing their
y out of his body. There was a sense
clamant energy. He wanted to get
to get on with an almost crying
gency; that is why he stumbled so
en over the heels of the man in front,
d why the man cursed him. At the
ne time he knew if he went back,
ned and went back, he would go with
same blind and frightful haste. Was
s fear? He did not recognize it.
was courage and panic mixed up in a
rile and frantic boiling. They turned
l twisted in the trench. Officers were
ing to them in voices of supernal
m, giving them trite orders as though
y were marching past the saluting
e at home. The calmness of the
eers was like cold water. It bit into
man: enabled him to hold his br-
g soul down. Something within
ate 43237 said: "Take a slower
steadier step. That'll calm you."
did so. The private behind him
ve against his back, and the private
nd yapped: "Git on. Git on.
on, dam you!"

ivate 43237 scowled at the private
nd. The infernal ass had got nerves.
ool like that caused panics.

ere was a slash of rifle-firing, abrupt
disturbing as the tearing of stout
n. Private 43237's heart jumped and
amed with it. The gunner was
ned by this noise. There was yelling
firing before them, and away to the
t; almost, it seemed, behind them.
achine-gun coughed, stuttered a lit-
then began to sew all sounds to-
er with short, whirring bursts.
ere were the thick and guttural ex-
ons of grenades.

ivate 43237 put his hand on the
et wall of the trench, and he half
ed. He wasn't afraid. No, it
t that. But he felt that someone
t to tell him what he ought to do.
eone ought to explain things to him.
felt extraordinarily alone. He felt
rdinarily hopeless and helpless. All
nce went from him for that moment.
did not even have the initiative to
Yet he was hoping someone would
so that he could follow. Down the
n an officer with a brass voice was
ng for "supports." The man in
of him was already round the
erse. He jumped forward. He must
up. The idiot behind him would
he was afraid. He wasn't afraid,
urse, but that fool hadn't the qual-
f mind to understand.

y were out in a long trench, lined
There were little ladders leaning
st the wall, reaching to the top of
sand-bags. He found himself in
of one of these ladders. He would
liked to shift along to a space
there was no ladder, but the other
might notice that. He climbed the
solemnly and slowly. He only did
cause other men, who watched him
ng, also did it. There was an
crouching at the top, his hand
out to hold them back. He was
ing the plain warily. Private
wished he could tear his eyes from
ficer's hand.

a the command. Private 43237
quickly to the top of the bags, and
ed. There was an enormous space
him. The place was hot and
ng with explosion. Away at an
e distance there seemed to be a
ion that might be fighting. But
didn't matter. It was the plain-
s leaping and gushing with smoke,
ugh a volcano burnt beneath. It
also enormous. He must be seen
e if he got on to it. He would
rribly conspicuous. All the guns
fire at him at once. They wanted
o be the first man on the plain.
w. They wanted to slip on to it
ross while the enemy concentrated
n. It was a conspiracy. And the
was so blank and enormous—save
e death in the smoke. He felt as
he were up on a tower and
Chilly and frigidly alone.
good God! there was another
n the plain, another and another:
ad come from the trench and were
forward. The ground was start-
d smoking about them. But they

were running. At once Private 43237
was on the plain, too. He was run-
ning, too. His fear of being alone had
gone. He was now fearing to be left.
Those men would beat him. He was on
the plain, running, running, running.
There was smoke all about him, blow-
ing in his face. There was loud noises
he did not place. He only knew that
he was running, and that some savage
thing was bursting through his flesh,
forcing its way out, exploding his body,
and settling about him like new tissues.
The wild and boiling excitement had
boiled over. It was bubbling and
clammering in his veins and heart, and
hammering in his head. Again he want-
ed to get his bayonet into the bowels of
someone. Again a swamping and ir-
resistible rage was making him a madman.
Where was a throat? Where was a
face? He wanted to stab, and batter,
and tear. He had the power of a giant
in his arms. He wanted to use it. He
had determined to use it.

A blur rose up striking with mad,
misty arms. The blur vanished in a
thin scream. And he was on, on; run-
ning, and on...

The whistles were calling, the whistles
were calling. An officer was pushing on
his chest, forcing him back. Holding
him back. And he was yelling. "Let's
go on! Let's go on! It's fine. It's
fine. I like it." But he did not know
whether he called this out with his
mouth or his heart. The officer was
telling them to dig in and hold on. It
was all over then. He'd come through
his first engagement.

Curious how elated he was. Curious
how disappointed he felt.—Sel.

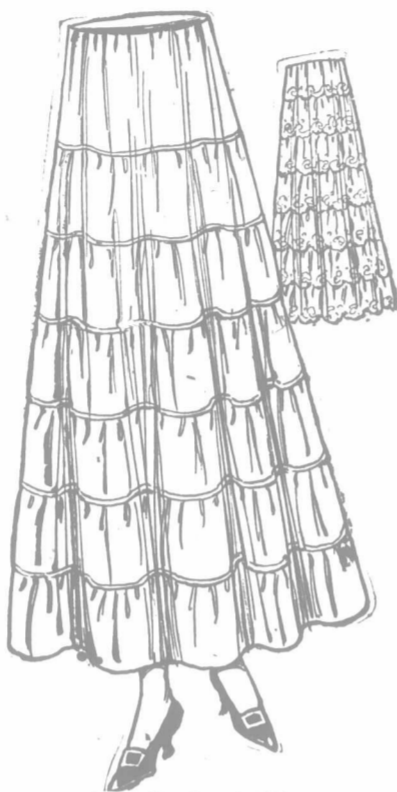

8648 Sectional Skirt, 24 to 32 waist.



8795 (With Basting Line and Added Seam Allowance) Princess Gown, 34 to 42 bust.



8714 Empire Negligee, Small 34 or 36, Medium 38 or 40, Large 42 or 44 bust.

Fashion Dept.

HOW TO ORDER PATTERNS.

Order by number, giving age or measurement as required, and allowing at least ten days to receive pattern. Also state in which issue pattern appeared. Price ten cents PER PATTERN. If two numbers appear for the one suit, one for coat, the other for skirt, twenty cents must be sent. Address Fashion Department, "The Farmer's Advocate and Home Magazine," London, Ont. Be sure to sign your name when ordering patterns. Many forget to do this.

When ordering, please use this form:
Send the following pattern to:

Name.....
Post Office.....
County.....
Province.....
Number of pattern.....
Age (if child or misses' pattern).....
Measurement—Waist, Bust.....
Date of issue in which pattern appeared.



8780 Middy Blouse with Adjustable Belt, 34 to 44 bust.



8801 Boy's Sailor Suit, 6 to 12 years.



8624 Girl's Dress, 4 to 10 years.



8782 Blouse with Tucked Fronts, 34 to 42 bust.



8557 Empire Dress for Misses and Small Women, 16 and 18 years.



8568 Girls' or Boy's Pajamas, 6 to 14 years.

A lawyer was arguing with a physician over the relative merits of their respective professions.

"I don't say that all lawyers are villains," said the doctor, "but you'll have to admit that your profession doesn't make angels of men."

"No," retorted the lawyer, "you doctors certainly have the best of us there."

It's good for little girls, too

Everybody— young and old— loves the rich, delicious flavor of



EDWARDSBURG "Crown Brand" CORN SYRUP

It is a daily treat—the perfect sweet. Just what the children should have on Bread—costs far less than butter or preserves. Delicious with Hot Biscuits, and Batter Cakes. Gives a new delight to Baked Apples, Blanc-Mange and Puddings. Makes the best Candy you ever tasted.

"LILLY WHITE" is a pure white Corn Syrup, not as pronounced in flavor as "Crown Brand". Your Grocer has both Brands, in 2, 5, 10 and 20 pound tins—or can easily get them for you.

The Canada Starch Co. Limited, Montreal



Kitchen Sink Outfit White Enameled Cast Iron

Price complete \$9.00 Delivered Free

FOR COUNTRY HOMES

At this low price we supply high-grade white enameled cast iron sink, 18x30 inches, complete, brackets and piping to floor, including trap. Also kitchen pump with reversible head, complete, with piping to floor, as illustrated. All iron pipe connections—any one can set up. Extra pipe at lowest prices.

The Halliday Co., Ltd. Factory Distributors HAMILTON CANADA

In many details of its construction, the SHERLOCK-MANNING "Canada's Biggest Piano Value" has qualities found in no other make. Write Dept. 18 for Catalogue "T" which gives a full description of these exclusive features. THE SHERLOCK-MANNING PIANO CO. London, Canada (No Street Address Necessary) 65

MATRICULATION BY MAIL The doorway to the professions—the first step towards becoming a doctor, lawyer, minister, civil engineer, electrical engineer, Scientific agriculturist, High School specialist, University graduate, etc.—is Matriculation. YOU MUST PASS THIS examination before you can begin your college course. We fit you AT HOME IN SPARE TIME. Write for full particulars. Canadian Correspondence College, Ltd. Dept. E., Toronto, Canada

Harab-Davies Fertilizers Yield Big Results Write for Booklet. THE ONTARIO FERTILIZERS, LTD. West Toronto

It means the bakeday smile of perfect satisfaction

PURITY FLOUR

"More Bread and Better Bread"

Westervelt School Y.M.C.A. BLDG., LONDON, ONT. BUSINESS AND SHORTHAND Students assisted to positions. College open Sept. 1st. Catalogue free. Enter any time. J. W. Westervelt J. W. Westervelt, Jr., C. A. Principal Vice-Principal

Alma (Ladies) College

A Christian college-home, healthful situation. For prospectus and terms, write the Principal R. I. Warner, M.A., D.D., St. Thomas, Ont. 63

CREAM

Where are you shipping now? And what are you getting for your cream?

We want more individual shippers and more men to gather cream for us.

Write for our proposition.

Silverwoods Limited LONDON, ONTARIO

The Windrow.

The new Briand Cabinet of France contains seven ex-Premiers.

The fine ceiling frescoes by Trepolo in the Church of the Scalzi, Venice, have been destroyed by bombs thrown from an Austrian airship.

Yuan Shi Kai, the President of China, has thirty-one children, enough, surely, to found a dynasty. He asserts, however, that the recent reports that he wants to be Emperor, are false.

There are nearly 1,000,000 men now serving in the British army at the front. Canada has sent 96,000 men, Australia 92,000, New Zealand 25,000, South Africa 6,500, Newfoundland 1,600, and the West Indies 2,000.

"There is going to be a new world altogether, and every man has in his hand the power to make or mar the new earth."—The Bishop of London.

"A man should never be ashamed to own he has been in the wrong, which is but saying, in other words, that he is wiser to-day than he was yesterday."—Alexander Pope.

"In the south-east of Europe no decision can possibly be expected. It is on the two great fronts, the Russian and the Western, and particularly upon the Western, that the war can be won by the Allies. It is there that the rapid decline of enemy numbers, when it begins, will produce the most startling and decisive results."—Hilaire Belloc.

King Ferdinand of Roumania, as a Hohenzollern, is, like King Ferdinand of Bulgaria and King Constantine of Greece, friendly to the Kaiser; but the Roumanian people, like the Greeks and many of the Bulgars, are rather inclined the other way. If they enter the war on the side of the Teutons it will be from interest rather than sentiment. The Central Powers have already offered Bessarabia as a bribe to Roumania, while the Allies have offered Transylvania. Russia is opposed to the former, and Austria to the latter transfer, but it is rumored that Russia has reluctantly consented.

AT THE PEARLY GATES. Dr. Jas. W. Robertson, Before the Ontario Teachers' Association.

"It will have been worth while to have been born on this earth, to have had a share in the teaching campaign, and when we each leave and go to the pearly gates, perhaps the record of it will not spoil our chance at the 'entrance examination.' Our materialistic Western minds do not lend themselves readily to the figures of Eastern speech and to the wealth of Eastern imagination. Who, in Toronto, thinking of a great indescribable country of glowing glory and desiring to feature the entrance, would speak of it as a gate? I never saw a gate in Canada to stir the imagination. So I will stick to the simple narration of a real occurrence to help me out. I see three boys walking along the sidewalk towards Ottawa—twenty years ago. The first one has one trouser leg up over his knee. I can see the muscles of his calves as he strides along, with a bit of some old cloth thing on his head for a cap. I can still see the carriage of his spirit, through his body, as he walks along. After him shuffled two boys in good clothes. They just shuffled along. What made the difference? The front boy had a string of fish and the other fellows had not caught anything. That made all the difference. And now I have a vision of the pearly gates. You, too, can see them. We all hope to pass through. There is St. Peter who has the keys, the old fisherman with 1900 years of experience in sizing up fellows who want to get in. And you see his noble, illustrious highness, the late Lord Successful, arrive. What does the old Fisher of Men ask? What wealth did you collect, and how much

did you leave? No, the old Fisher of Men knows real values and real sport. He is not impressed by any one who spent his time collecting dead fish. A teacher, who taught school forty years, comes along. I see the twinkle of joy in the eyes of the old Fisher of Men. What have you got? What did you do? 'I could not save anything; I taught school in Ontario.' 'And you helped girls and boys?' 'Yes, for forty years, perhaps ten or so a year, as best I could.' You can see the gates swing open. A fisher with a string of 400 has been welcomed through. I wish you joy in the game, and like glory in the end."

WHAT THE SOLDIER EATS.

"Rations." By a Subaltern, in the Daily Mail, London.

Rations at the front consist of five chief items—biscuits, cheese, jam, tinned meat, and tea. It might be thought that this fare, day after day, for week after week, would become monotonous. But appetites remain keen, the items themselves are slightly varied, and the general verdict of the soldier in the trenches is that he is well fed.

Army biscuits are of three kinds—ordinary, brown and crackly, and buttons. The ordinary are the least appetizing; they are of a whitish-brown hue, with no particular taste. They are, however, very much better than nothing, and with jam, or a slice of bully beef, quite good. The brown and crackly have a taste of porridge and brown sugar; they are very nice indeed, and pleasant to eat by themselves. The buttons have not much flavor, but are fascinating little biscuits, small and fat, about the size round of a two-shilling piece. They are not often issued, but when they are the custom is to stuff one's pockets with them and dip into them throughout the day.

Cheese does not vary much. The richer kinds, such as Gorgonzola, are for obvious reasons not issued. At the front it would be impossible to extend the disciplinary measures which govern the issue of rations to the control of Gorgonzola cheese. The cheese issued is of the good, plain, dark-yellow variety, and each man gets a handsome wedge a day.

Jam is issued in 1-lb. tins—a tin roughly to every seven men. The idea is that one man should carry the tin, and the others share it with him at a chosen time. In practice, men outside the "firm" join in the banquet, and the tin is finished and thrown away, or kept for bomb manufacture. At a later hour in the day, the ones who joined in produce a tin of their own, which the first firm share and help to empty. By this means the difficulty of carrying an open and half-empty tin of jam in the haversack is overcome. It has happened that in the excitement of an attack, an opened tin of jam instead of a bomb has been thrown by mistake. Jam at the front is of many kinds—strawberry, raspberry, apricot, greengage, marmalade. The best-known variety is "plum and apple."

Tinned meat also varies. There is Fray Bentos—generally known as bully. This is pink, stringy, and of a salt flavor. When nothing else can be procured—as often happens—the men eat it gladly enough. Cut in slices on a biscuit it is quite palatable. But it is not a thing which anyone would eat out of sheer gluttony. Stewed with potatoes it is quite good, and this is the way the men generally have it when they are in billets or anywhere where they can cook. The French peasants near the firing line quite like Fray Bentos, and get a good many tins given them.

An extremely succulent form of tinned ration is the McConachie. This is a tinned stew with a rich gravy and vegetables. The tin should be placed in boiling water and heated up for twenty minutes. When opened, a delicious hot stew is found, ready cooked. One tin will make a good dinner for three men. Mistakes have been made in preparing this ration. On one occasion I saw a party of men with a tin of McConachie sitting round a fire. They had no water, so they had put the tin on the fire just as it was. Suddenly one of them exclaimed: "Blimy, Bill, look at that tin blowin' itself out!"

The tin was swelling gently in the heat.

ou leave? No, the old Fisher of knows real values and real sport. s not impressed by any one who his time collecting dead fish. A er, who taught school forty years, along. I see the twinkle of joy e eyes of the old Fisher of Men. have you got? What did you do? ould not save anything; I taught l in Ontario. 'And you helped and boys?' 'Yes, for forty years, s ten or so a year, as best I ' You can see the gates swing A fisher with a string of 400 has welcomed through. I wish you joy game, and like glory in the end.'

WHAT THE SOLDIER EATS.

"Rations."
Subaltern, in the Daily Mail, London.

ons at the front consist of five items—biscuits, cheese, jam, tinned and tea. It might be thought this fare, day after day, for week week, would become monotonous. appetites remain keen, the items selves are slightly varied, and the l verdict of the soldier in the es is that he is well fed.

y biscuits are of three kinds—ordi- brown and crackly, and buttons. rdinary are the least appetizing; are of a whitish-brown hue, with rticular taste. They are, however, uch better than nothing, and with r a slice of bully beef, quite good. own and crackly have a taste of e and brown sugar; they are very ndeed, and pleasant to eat by lves. The buttons have not much ut are fascinating little biscuits, and fat, about the size round of shilling piece. They are not often ut when they are the custom is one's pockets with them and dip hem throughout the day.

se does not vary much. The richer such as Gorgonzola, are for obvi- reasons not issued. At the front it be impossible to extend the dis- ry measures which govern the issue ons to the control of Gorgonzola

The cheese issued is of the plain, dark-yellow variety, and an gets a handsome wedge a day.

is issued in 1-lb. tins—a tin y to every seven men. The idea t one man should carry the tin, e others share it with him at a time. In practice, men outside rm" join in the banquet, and the finished and thrown away, or kept b manufacture. At a later hour day, the ones who joined in pro- tin of their own, which the first are and help to empty. By this the difficulty of carrying an open lf-empty tin of jam in the haver- overcome. It has happened that excitement of an attack, an tin of jam instead of a bomb has own by mistake. Jam at the of many kinds—strawberry, rasp- apricot, greengage, marmalade.

st-known variety is "plum and

l meat also varies. There is entos—generally known as bully. s pink, stringy, and of a salt When nothing else can be pro- os often happens—the men eat it enough. Cut in slices on a bis- is quite palatable. But it is not which anyone would eat out of gluttony. Stewed with potatoes ite good, and this is the way the herally have it when they are in or anywhere where they can cook. nch peasants near the firing line ke Fray Bentos, and get a good ns given them.

remely succulent form of tinned is the McConachie. This is a stew with a rich gravy and vege- The tin should be placed in water and heated up for twenty

When opened, a delicious hot found, ready cooked. One tin ke a good dinner for three men- have been made in preparing ion. On one occasion I saw a y men with a tin of McConachie round a fire. They had no so they had put the tin on the as it was. Suddenly one of claimed: "Blimy, Bill, look at blowin' itself out!"

in was swelling gently in the

"Ere, prick it, quick," said another; "it'll go off." The first speaker drew his clasp knife, knocked the tin off the fire, and jabbed it with the blade. There was a shrill whistle, and a jet of gray steam shot skyward. The others danced with vexation at seeing the precious stew being wasted. However, there was nothing for it, and nature had to take its course. When the steam had worked off the tin was cautiously opened and the men sat down to what was left of their meal.

Tea is generally issued as a combined ration with brown sugar, the tea and sugar being mixed up and served out together. Like the jam, the tea is issued to small firms, the principal of the firm carrying the tea wrapped up in a piece of paper or a handkerchief. When a chance occurs a bit of a fire is lit, two or three canteens of water are set to boil, and when the water is boiling the tea and sugar are thrown into it; the tea is then drunk Chinese fashion, leaves and all. It is strong, and, of course, sweet, but very warm and comforting on cold nights and mornings. There is nothing the men appreciate more than a drink of tea, and they will make a brew on every possible occasion. Smoke gives away a position and draws artillery fire, so strict orders have to be given about the lighting of fires in the front trenches. The ordinary danger of a stray bullet from a sniper has no terrors, however, for a man who wants to make tea.

Men will get out of their trenches and start to make tea when little else would get them to leave cover. Some of the more confirmed teadrinkers carry little cans or tins which they have picked up somewhere. These little pots are black and grubby beyond description, but at the first halt the owner may be seen to slip his pot from its hook, hastily gather a few sticks by the roadside, and start to brew. The men who carry these pots are well known to their company officers, for they are a source of danger to the others; in a night attack the pot may be heard rattling and clattering against the men's equipment for three hundred yards.

Rations in the firing line are generally issued in the small hours of the morning, when the regimental quartermaster, having received them from the supply column, brings them up from the scond-line transport. Each company then sends down a ration party, which brings back the rations by hand, and they are distributed to sections. The officers draw the same rations as the men, and in each company one officer is generally constituted Officers' Mess President, and made responsible that the other officers get their rations. His task is not always easy, as the others object to being loaded up with a tin of bully, four biscuits, a bit of cheese (not wrapped in paper), a handful of tea, and so forth—and at the same time, if they refuse to carry them, they blame the Mess President if they have nothing to eat at the end of the day.

A word for rum. Let not any man who has never slept out on a cold December night try to stop the issue of rum to the troops this winter. It is little enough they get, a couple of mouthfuls each perhaps, but what warmth and cheer there is in that little drop, taken when the man, tired after his day's work, lays himself down to sleep, wrapped in his overcoat, on the frost-bitten ground. I have heard the temperance advocates say that alcohol only gives a temporary "fillip" to the system and does no real good. Be that as it may, but let not those at home try to deny this "temporary fillip" to the men out there, lest the ghost of an infuriated Tommy should haunt their sick-bed and push the barley water out of their reach.

News of the Week

The hospital ship Anglia, bound from France for Dover, with 300 wounded men aboard, struck a mine in the English Channel on Nov. 17th and sank. Eighty-five were drowned.

A great recruiting rush is reported from London, Eng.

Twelve thousand Arabs are said to have joined the British army in Mesopotamia.

"Sovereign" Treasure Steel Ranges Will Last

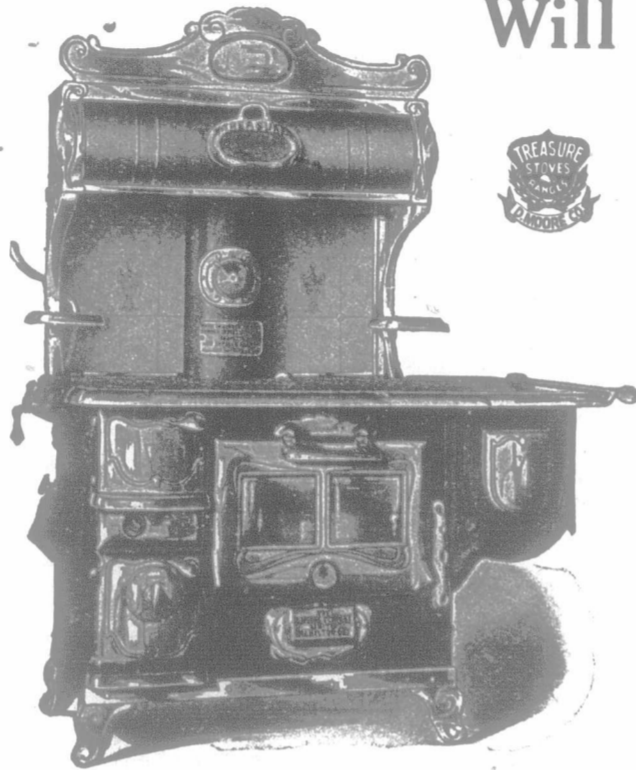

[Style—Reservoir with Glass Door and N. P. Tile-High Closet.

Do you want a High-class Range like that? It is money well spent. A Canadian-made Range is better put together. This is "Standard of Perfection."

"SOVEREIGN TREASURE" Ranges are fitted with our latest Patent Ventilated Life-Long Firebox Linings. Are so constructed that there is a continuous current of air behind the Linings and connected with Ventilator Pipe to Flues of range, this prevents warping, also gives additional heat to the Oven.

Fireback and Firefront Sections are interchangeable and interlocking.

Every Range fitted with Thermometer.

With or without Glass Oven Door.

Special Wood Firebox. Will take 28-in. wood.

Tile-High Closet—Frosted Green or very rich Ivory Tile.

Made with either Right or Left Hand Reservoir.

Top has six covers in three sections.

Front Section lifts up for Broiling, Toasting and putting in Fuel.

Ask your dealer to show you the "SOVEREIGN TREASURE," or write us for booklets and full information of same.

THE D. MOORE COMPANY HAMILTON, ONTARIO LIMITED

Largest exclusive manufacturers of Stoves and Ranges in Canada

Winnipeg Branch: Cor. Market and Princess Sts. J. A. EVANS, Agent

JOHN BURNS, Railway St., Vancouver, B. C.

THIRTY-SECOND ANNUAL

Ontario Provincial Winter Fair

Guelph, Dec. 3rd to 9th, 1915

At CANADA'S oldest and biggest Winter Fair this year you will see the largest display of the BEST STOCK produced on the BEST FARMS in Canada ever brought together at one show. You cannot afford to miss it.

SINGLE FARE ON ALL RAILWAYS

WM. SMITH, M.P., President COLUMBUS, ONTARIO

R. W. WADE, Secretary

Parliament Buildings

TORONTO, ONTARIO

HUNT'S DIAMOND FLOUR

Established 1854

Used by women of experience and discrimination for 60 years. Their success in baking is due to our special blend that is guaranteed to be "Always the same."

Good Grocers Sell Hunt's. 1673

HUNT'S BEST

War news this week indicates that the great struggle has reached its crisis. Reports from the Russian front are optimistic, and with the exception of some heavy fighting near Ypres, all has been fairly quiet along the Western front, but in the Balkans conditions are critical. The Bulgar victory at Monastir put the enemy practically in possession of Serbia, although the Serbian army, in retreat towards Albania, may make another stand. Latest reports state, however, that the British have arrived there, and that the Bulgars have evacuated. Meanwhile, owing to the uncertainty in regard to Greece, the Allied troops have been much hampered, except near Veles, which the French have been endeavoring to reach in the hope of cutting off the Bulgarians in Southern Macedonia from their supply bases. The King of Greece, urged by his Hohenzollern sympathies, has declared that he will intern any Serbian or Allied troops that may retreat into Greece, and the suspicion grows that he will use his army, contrary to the will of many of his subjects, to fight the Allies on some trumped-up excuse. On the other hand, it is affirmed that he has stated to Kitchener that a satisfactory arrangement may be reached. Be that as it may, the British have ordered that no further loading of Greek ships in British ports will be permitted. In Roumania, too, conditions exist very similar to those in Greece; the King, a Hohenzollern, sympathizes with the Teutons, in opposition to the Liberal leader, Take Jonescu, who, like Venizelos, is in favor of the Allies. . . . Every day the Allies are still landing troops at Salonika, among them, a number of Italian troops. The justification for this is found in the fact that by the Treaty of Bucharest, Serbia obtained access to the sea over Greek territory, and a strip of water frontage at Salonika for harbor purposes. In the meantime, Earl Kitchener has conferred with Generals Monro and Sarrail in the East. . . . From the Far East has come a report that trouble is brewing between Japan and China. It is also reported that the Entente is endeavoring to secure an alliance with the latter country.

Cavalry Sergeant—"I told you never to approach a horse from the rear without speaking to him. First thing you know they'll kick you in the head, and we'll have a bunch of lame horses on our hands."—Judge.

Mistress—"Bridget, the pie is awful! And you told me you could bake as good pies as any cook in Rangeville." Bridget—"So I can, mum. But all the ladies I ever worked for mixed the pies themselves before I baked 'em, mum."

Give Me a
Chance to Prove
My Flour



Cream of the West Flour

The hard wheat flour guaranteed for bread

With every bag of Cream of the West flour there goes a guarantee. That guarantee means that we believe Cream of the West to be the best bread flour on the market. If your bread doesn't beat any that you baked before, if it fails to rise or doesn't give extra satisfaction in every way, we will pay you back your money on return of the unused portion of the bag. Read the following prices on flours and cereals direct to farmers.

GUARANTEED FLOURS	Per 98-lb. bag.
Cream of the West Flour (for bread).....	\$3.30
Toronto's Pride (for bread).....	3.10
Queen City Flour (blended for all purposes).....	3.00
Monarch Flour (makes delicious pastry).....	3.00

CEREALS	
Cream of the West Wheatlets (per 6-lb. bag)....	.25
Norwegian Rolled Oats (per 90-lb. bag).....	2.70
Bob-o'-Link Cornmeal (per 98-lb. bag).....	2.20

FEEDS	Per 100-lb. bag.
"Bullrush" Bran.....	1.25
"Bullrush" Middlings.....	1.30
Extra White Middlings.....	1.45
"Tower" Feed Flour.....	1.75
Whole Manitoba Oats.....	1.80
"Bullrush" Crushed Oats.....	1.85
"Sunset" Crushed Oats.....	1.70
Manitoba Feed Barley.....	1.85
Barley Meal.....	1.90
Geneva Feed (crushed corn, oats and barley)....	1.80
Oil Cake Meal (old process, ground fine).....	2.25
Chopped Oats.....	1.85
Feed-Wheat.....	1.65
Whole Corn.....	1.70
Cracked Corn.....	1.75
Feed Corn Meal.....	1.70

Prices on Ton Lots: We cannot make any reduction on above prices, even if you purchase five or ten tons. The only reduction from the above prices would be on carload orders.

Terms Cash with Order: Orders may be assorted as desired. On shipments up to five bags, buyer pays freight charges. On shipments over five bags we will prepay freight to any station in Ontario, east of Sudbury and south of North Bay. West of Sudbury and New Ontario, add 15 cents per bag. Prices are subject to market changes.

GET THIS HANDY HOUSEHOLD BOOK, FREE.

With every purchase from us of not less than three bags of Campbell's flour (any brand) you will get from us a free copy of "Ye Old Miller's Household Book." Add 10c. to your remittance to cover postage and wrapping of book. This is one of the most remarkably complete and helpful household volumes ever prepared. The 1000 recipes alone are worth the regular price of the book (\$1.00).

The recipes cover every kind of cookery from soup to dessert—from the simplest to the most elaborate dishes. Every recipe is dependable and not too expensive or troublesome to prepare. They always come out right. Full instructions are given to carve meats and game with many graphic illustrations. And in addition there is a big medical department in this wonderful book that should be in every home. It tells in simplest language how to deal with almost every common malady. You must get this book—read how simple it is to get it free.

ADDRESS ALL LETTERS TO

The Campbell Flour Mills Company
LIMITED
(WEST) TORONTO ONTARIO

The Dollar Chain

A fund maintained by readers of "The Farmer's Advocate and Home Magazine" for (1) Belgian Relief; (2) Soldiers' Comforts; (3) Red Cross Supplies.

Contributions for the week from Nov. 12th to Nov. 19th, were as follows: August Lang, Port Perry, Ont., 60 cents; Mrs. Edward Smith, Claude, Ont., \$1.00; "An Unknown Quantity," \$1.00; Annie A. Rogers, R. 3, Woodford, Ont., \$3.00.

Amount previously acknowledged\$1,905.25

Total to Nov. 19th.....\$1,910.85

Kindly address contributions to "The Farmer's Advocate and Home Magazine," London, Ont.

IF YOU CANNOT GO TO THE FRONT YOURSELF, AND IF YOU HAVE NO ONE TO SEND, AT LEAST SEND YOUR DOLLARS.

In regard to the JAM SHOWER, please understand that the notice that jam enough has been received for the present, only applies to the London, Ont., branch of the C. W. C. A. (Soldiers' Comforts Dept.). Other branches in other places may be still packing, and may gladly receive your contributions. Notice will be given when a clearing has been made in this city, so that a call for more can be issued to "The Farmer's Advocate" readers.

The Love Story of a Homely Girl.

AS TOLD BY HERSELF.

Although I have always been fully aware of my shortcomings in the matter of beauty, I suppose, like the rest of my sex, I hoped. Somewhere hidden away in my heart was the thought that perhaps someday I might meet the man of my dreams, who would be generous enough to overlook mere beauty, and love me for what I was striving to be.

A cruel awakening to the fallacy of this idea, came in one terse sentence which fell upon my ears unexpectedly. It came from my sister-in-law, and I felt the full force of its significance, for with a family interest she rather hoped I would marry and have my own home.

"Jane will never marry—she is too homely and altogether unattractive."

The words cut into my feelings with merciless sharpness. I knew Martha did not intend that I should hear them, for she is good-hearted and would not have hurt my feelings by such a speech. But I was an innocent and unwilling listener and, what was worse, must hear the conversation out or reveal my presence and cause both her and my brother, with whom she was conversing, untold embarrassment, for they were discussing my future prospects.

In that half hour I awoke to a full consciousness of the miserable and unhappy plan of my life. Fate had not only given me the reddest of red hair, china-blue eyes that turned green in certain lights, freckles, and a nose that was undeniably pug, but had heaped further indignities upon me by bringing me into the world to become the resident of a small Southern village of narrow-minded people.

As a young girl I never had admirers. The girls with whom I had gone to school had passed through the usual experiences of life in a small village: church socials, dances, card parties, teas, and the inevitable courtship and wedding. I was always the outsider, the wallflower. For a while I had mingled with the girls as one of them, accepting my fate as it was thrust upon me, but ever alive to the fact that I was neither popular nor pleasing. I tried to find my pleasure in real friendships, for these I had. But as my friends married and settled down to home life, or left the village, I gradually gave up social life.

One incident stands out in my memory, and even now sets my heart beating quickly and sends the warm color to my face, as I think of the embarrassment I endured. While at a dance one evening I met a gentleman from Baltimore. He was a big, jovial man who could make anyone he met feel flattered just by his manner of being

absorbed in the one he was talking to. I was standing at the far end of the room with one of my friends, Anne Carroll, a very pretty girl, and he was introduced to us at the same time. He talked to me quite a good deal after that and addressed me once or twice as Miss Carroll, using my name in speaking of Anne. I thought nothing of the incident, attributing it to confusion during the introduction and dismissed the matter from my mind. A few days later I received a note from the gentleman asking if he might call. I was in a sudden fever of pleasure. His personality had attracted me strongly, what if he could? I did not dare to think further. It was all so improbable. I answered his note and set a time for him to call. I shall never forget the misery of that evening. I had taken extra pains with my gown, and used every little art I knew in an endeavor to be more attractive and, as is the usual result in such cases, I suppose I appeared more dowdy and unattractive than ever.

When I entered the room and held out my hand to greet him, an expression passed over his face that carried to my heart like an electric shock the full significance of the situation. He had confused me with Anne Carroll!

He acted splendidly, bravely carried the thing through to the finish, for he was a gentleman, but I knew his evening was spoiled. If his evening was unpleasant, mine was one of bitter humiliation. Needless to say he never called again.

This incident sent me into a period of deep depression and reserve, from which I never wholly emerged. No one but a really homely woman can realize what it means to go through an experience of this kind in a small village where every move and every sentiment is public property.

Two years after this Father died rather unexpectedly and left me not only helplessly incapable of earning a dollar, but deprived even of the substantial substance that would permit me to become so. There was but one thing to do. It was what all unmarried females were expected to do who were members of these very genteel families—become the dependent in the home of some male relative.

Martha, my only brother's wife, had three small children, and since Brother Fred was still far from the summit on the hill of achievement in his profession she could not be expected to welcome me with enthusiasm, especially when, in her estimation, I was destined to be a life member of her family. I give her credit, however, for acting very well under the circumstances.

Fortunately for me, I loved children, and Fred's youngsters were my saving grace. I had an infinitesimal income, which would clothe me and provide small necessities; and after a few months my conscience no longer troubled me in the matter of being a dependent. I knew that I was rendering services to Fred and Martha far in excess of the value of my board.

My life settled down into a monotonous routine relieved only by my joy in the children, their great love for me, and the consciousness that I was an influence for good in their young lives. The happiest hour of my day was when I gathered the three little night-robed figures about my knees for their evening prayers and then tucked them away in bed, with perhaps a song or a happy story to send them off to sleep. After this I would plunge into the mending basket, which even with my almost constant attention seemed to be always full. It was indeed a sorry outlook for a young woman of twenty-six, a woman who still held a heart full of ideals, and felt a woman's desire for a woman's life in a sphere of her own creating.

For nine years I plodded along, accepting the uneventful trend of my life as best I could. Often in my twilight dreaming as I sang or read the children off to sleep, I would let my imagination play over a possible emancipation. Even at thirty-five I could dream into the future a home all my own, which would be filled at least with a love so broad, so overwhelming, that it would brighten everything about it.

I wonder if all homely women have these thoughts. I think they do, for the woman's love for admiration, the



YOU have the "The M... THE simple allows yo... compositi... nowned Music... and delicacy o... to the "Mest... is found only

NEG... GIL... PLA

Under your "Master-Touch" to impart the accuracy that distinguishes the playing of a m... color inspiring roll that you... mechanical.

The "Master Without S... If you have a... and have never cultivate your... experience the... sonally produci... a New Scale W... Convenient to allowance mad

Our beautiful "Critic" will in... DAY address... The Will... OSHAWA

Make Money Pulling Stumps

Add new, rich... your own farm... clear your neig... cules will be ke... what it does... With the

Hercules

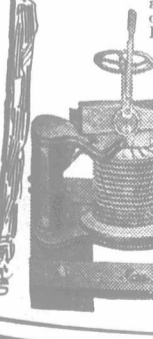

WE Alsike, Red Alfalfa C... T... Write us and send... GEO. KEI... Seed Merch... 124 King St. E.

in the one he was talking to. standing at the far end of the... the one of my friends, Anne... very pretty girl, and he was... to us at the same time. He... me quite a good deal after... addressed me once or twice as... I thought nothing of the in-... tributing it to confusion dur-... introduction and dismissed the... from my mind. A few days... ceived a note from the gentle-... if he might call. I was in...iever of pleasure. His person-... attracted me strangely, what...? I did not dare to think... It was all so improbable. I... his note and set a time for... all. I shall never forget the... that evening. I had taken... with my gown, and used... art I knew in an endeavor...re attractive and, as is the...lt in such cases, I suppose I...more dowdy and unattractive

entered the room and held out... to greet him, an expression... his face that carried to my... an electric shock the full sig-... of the situation. He had con-... with Anne Carroll!

splendidly, bravely carried... through to the finish, for he... tleman, but I knew his even-...poiled. If his evening was... mine was one of bitter... Needless to say he never

gent sent me into a period of... sion and reserve, from which...olly emerged. No one but a...ely woman can realize what... go through an experience of... a small village where every...ent sentiment is public

ers after this Father died... expectedly and left me not...ssly incapable of earning a... deprived even of the sub-...stance that would permit me...so. There was but one... It was what all unmar-... were expected to do who...ers of these very gentle...ome the dependent in the...e male relative.

my only brother's wife, had... children, and since Brother...ill far from the summit on... achievement in his profession...t be expected to welcome me...asm, especially when, in her... I was destined to be a life...her family. I give her...ver, for acting very well un-...stances.

for me, I loved children,... youngsters were my saving...ad an infinitesimal income,...d clothe me and provide...aries; and after a few...y conscience no longer...in the matter of being a...I knew that I was render-...to Fred and Martha far in...value of my board.

bled down into a monoton-...relieved only by my joy in...their great love for me,...sciousness that I was an in-...d in their young lives...hour of my day was when...e three little night-robed...y knees for their even-...nd then tucked them away...perhaps a song or a happy...them off to sleep. After...plunge into the mending...h even with my almost...ntion seemed to be always...nded a sorry outlook for...an of twenty-six, a woman...d a heart full of ideals, woman's desire for a wo-...a sphere of her own

ars I plodded along, ac-...eventful trend of my life...d. Often in my twilight...sang or read the children...I would let my imagin-...a possible emancipation...-five I could dream into...home all my own, which...at least with a love so...whelming, that it would...thing about it...all homely women have...I think they do, for...love for admiration, the



YOU—Yourself—
have the power to play "The Music of the Stars"

The simple insertion of a music roll allows you to play instantly the compositions of the World's Renowned Musicians with the expression and delicacy of the composer—thanks to the "Master-Touch" device which is found only in a

NEW SCALE WILLIAMS PLAYER PIANO

Under your slight pressure of the "Master-Touch" buttons you are able to impart the correct interpretation so accurately that it is almost impossible to distinguish the music from the hand playing of a musician. You bring out color inspiring variety from a music roll that you thought would sound mechanical.

The "Master Touch" Device Shades Without Smothering the Tone

If you have a fondness for the piano and have never had an opportunity to cultivate your desire, you will never experience the extreme delight of personally producing music until you own a New Scale Williams Player Piano. Convenient terms, and a generous allowance made on your piano.

Our beautiful catalogue "Art and Critic" will interest you. Write TO-DAY addressing Dept. C-2

The Williams Piano Co.
OSHAWA LIMITED ONTARIO

Make Money Pulling Stumps!

Add new, rich, crop growing land to your own farm by clearing it of stumps. Clear your neighbors' land. Your Hercules will be kept busy when others see what it does. Big profits for you. With the

Hercules All-Steel Triple Power Stump Pullers

you can clear an acre a day. The known and proved stump puller all over the most durable. Special introductory price, 30 days' trial offer, 3 years' guarantee, on immediate orders. Write for big Free book of land clearing facts.

HERCULES MFG. CO.
1136 24th St.
Centerville, Iowa

WE BUY Alsike, Red and Alfalfa Clovers and Timothy Seed

Write us and send samples.

GEO. KEITH & SONS
Seed Merchants Since 1866
124 King St. E. TORONTO

woman's hunger for love and sympathy, are not wiped out of her heart by the color of her hair or the shape of her nose. No woman can find her highest happiness in mothering another woman's babies, even though they are near and dear, as Fred's children were to me. I had the whole care and responsibility without the rare joy of shaping their young lives entirely as I would wish. Sometimes the two older children as they kissed me good night would say: "Aunt Jane, you won't ever get married and leave us, will you?"

I could never answer except with a kiss, for I was always foolish enough to feel a sudden choking lump in my throat, partly gratitude for the affection they displayed and partly self-pity for the improbability of such a happening. Bless their hearts, they, at least, were unconscious of my physical imperfections, and, like David, in his admiration, for Peggotty, could see only beauty in the face they had learned to love.

One day the clouds broke; and I was sent suddenly into a whirl of genuine excitement. I was preparing peaches for the summer canning when Martha came excitedly into the kitchen waving a letter:

"Jane, what do you think? Elsie wants you to come to South Africa!" For a moment I could not speak. Elsie, my older sister, who had been married for fifteen years, who was always too busy or too happy to keep in close touch with her family, wanted me to come to her. My senses could not take in the situation all at once. I took the letter Martha handed me and tried to read it, though the words seemed to blur before my eyes.

Yes, it was true; she had written to ask Martha to approach me on the subject and see if I would be willing to go. I suppose she had an idea that in some way I was indebted to Martha and she must in a measure gain her consent to ask me. I felt no such indebtedness. Somehow the tone of Elsie's letter sent a sudden resolve to my heart. A strong inner feeling stirred me to the point of definite action.

"I think I will go, Martha." For a moment Martha was dumbfounded. I knew what was passing in her mind. I was child's nurse, seamstress, housekeeper and chambermaid. It would mean a great difference in her duties as well as increased expense. The children were uppermost in my mind; it would be hard to leave them—but a new life, a broader life in Johannesburg was calling to me, a long ocean voyage change and excitement. The sister I had not seen for fifteen years wanted me—yes, I would go.

That night I wrote Elsie and asked her to give me full details, and I frankly and plainly stated the condition of my finances, for I knew that Elsie's husband was well-to-do and that there would be a certain appearance to be maintained. Her return letter brought joyful news. She wanted me to share the life out there. She knew I was capable of development in city life, and now that the children required less of her attention she wanted me. Her letter enclosed a draft for five hundred dollars for clothes and expenses. I immediately deposited fifty dollars for each of the three children as a parting gift, and with part of the remainder set out to buy an outfit for the trip.

No bride was ever gayer or happier in the purchase of her trousseau. I went straight to New York and reveled in the joy of purchasing a simple but pretty outfit. Another week was spent at home preparing for departure. Away back in my heart was a feeling that I scarcely dared to frame into anything definite. Some force was actuating me that I could not understand. Every act connected with my prospective journey seemed to be perfectly natural. Things moved along as though I had planned them years ahead, and always in my heart was the thought—I am going home. Somehow Martha's house had never seemed home to me. I was in the family but not one of them. Martha and Fred had their own friends, and I was rarely included in their social life.

It was not until the vessel was well on its way that I fully realized the great break I had made in my life. The voyage, though long, proved pleasant,

but I had to keep ever before me Elsie's merry, smiling face as it showed in her last photograph, to fight off the homesickness that would sweep over me.

I was a happy woman when Elsie at the end of the trip folded me in an impetuous embrace; and when John, whom I scarcely knew, acted as though I was the one event in his life for which he had been waiting for years, I felt that the cordiality of their welcome was all my homesick heart could ask.

We went at once to their home and I was taken to a lovely room all my own. My feeling that I was going to a real home was fully realized. I felt it that first day, and it grew stronger and stronger in all the days thereafter. As was natural, I was tired from my trip, and for a little while we did not see any guests or go about very much, but after that began days of the most delightful social life among the kindest-hearted, most hospitable people in the world, who did not stop to think, apparently, of my extreme homeliness. Since everyone else forgot it, I, too, managed to forget it.

At the first little dinner party that Elsie gave for me, John, my brother-in-law, came up, bringing with him a tall Englishman, whom he introduced to me as his dear friend, Richard Nevill. As I shook hands with him I felt the blood rush to my cheeks as though I were a girl of sixteen. Elsie said afterward that I looked like a woman transformed in that moment, and indeed I felt it. I soon learned that Dick Nevill was almost a constant visitor at my sister's home, and with Elsie's two boys we formed a jolly sextette. Sometimes, indeed very often, Dick and I were felt to our own devices, and we did not miss the others. He taught me to ride, read with me, talked with me and was always a kind and thoughtful friend. I may confess without blushing that I was never so happy as when he was with me, and I found in his companionship a pleasure so deep, so vital, that it sometimes almost frightened me.

One day when we were alone together he drew from his pocket an old faded photograph.

"Do you recognize this?" he asked. It was a picture I had had taken about six years before with Martha's children about me. There they were, the three little darlings, Ted, the youngest, with his chubby arms about my neck.

"I came by this quite accidentally," he went on. "John, one day, while pulling an old letter out of his pocket, dropped this photograph. I picked it up, and liking the womanly face it portrayed, thrust it in my pocket for closer scrutiny in private. I could never come to the point of returning it to its owner. That face has been dear to me now for many months, for in it I caught a glimpse of the soul-light that I need in my life. Perhaps you cannot understand this, but my life has been very unhappy. I have never seemed to belong to anyone—to have anyone really interested in whether I succeeded or failed. Of course I know it will be difficult for you to realize what this pictured face has been to me, how I have learned to look upon it as belonging to me. For a long while I thought it was the face of the children's mother, and then one day the story of your life came out. Elsie told it so naturally, so sweetly, that I could see you living quietly in that little village, giving up your life for these children, and then a selfish feeling took possession of me. I—wanted you."

I had turned partly away from him as the full significance of his words came to me. That picture did not show my red hair, my freckles, even my ugly nose was softened into a respectable shape. The whole miserable scheme seemed to open up before me. He had fallen in love with the pictured face, as he imagined it was, had persuaded Elsie to invite me to Johannesburg—and now—he was sorry for me, was going to make a sacrifice. I must ask the question that was stifling me.

"You—you—can't think I am anything like that picture? I—oh, it is only your pity for me!"

The next few moments are too precious to recount. I suppose when a homely woman has a great love in her life, when all the months and years prior to this awakening have been a

Every Woman May Possess

A soft and delicate-colored skin, no matter what her vocation. A little care of the complexion is all that is necessary. Many farmers' wives and daughters write for our booklet "F" and consulting blank, fill out the latter, act on our advice, and obtain what is every woman's due.

A Good Complexion

We make no impossible promises, and our fees are moderate. There is no charge for consultation either in our office or by mail. We have reliable home treatments for all skin and scalp troubles, it makes no difference how long the patient has been afflicted.

All physicians acknowledge that Electrolysis is the only sure treatment for that masculine blemish, SUPERFLUOUS HAIR, and it is the most satisfactory for MOLES, WARTS, RED VEINS, etc. We assure satisfactory results in each case. Our method is recommended as superior to others. Twenty-three years experience.

Hiscott Dermatological Institute
61 COLLEGE ST., TORONTO

BE YOUR OWN Blacksmith

FREE INSTRUCTIONS
In farm blacksmithing and horse-shoeing.

Learn how to repair your own wagons and farm machinery. How to shoe your own horses. Learn the secrets of tempering and hardening metals. Be your own blacksmith.

SAVE MONEY FROM THE START
Write now and secure special direct-from-foundry prices on a forge and all necessary tools for practical work. Just the chance farmers are looking for.

LIBERAL DELIVERY OFFER
We Pay Freight Ontario and East and as far as Winnipeg West.

The HALLIDAY COMPANY Limited,
Factory Distributors,
Hamilton, Canada.

CREAM PRODUCERS

You buy a cow on the strength of past performances. You should apply the same test to the creamery you patronize. If you are not already shipping to us, get our prices for the past summer and convince yourself that it will pay you to start now. Can furnished. Express paid.

VALLEY CREAMERY, Ltd., Ottawa, Ont.

CREAM

We pay express charges and furnish cans

REMIT PROMPTLY
Take all you can make

WRITE US
THE BERLIN CREAMERY CO.,
BERLIN, CANADA

Brant Creamery
Brantford, Ontario

Guarantees to you a high-priced market for cream every day of the year.

Write for our book.

Reference: Bank of Nova Scotia.

When Building—Specify

MILTON BRICK

Smooth, Hard, Clean-cut.
Write for Booklet.

MILTON PRESSED BRICK COMPANY
Milton, Ontario

Richards

QUICK NAPTHA

THE

WOMAN'S SOAP

MADE IN CANADA

ROUP



You can prevent and cure Roup, and avoid trouble and loss by using **Pratt's Roup Remedy** (Tablets or Powder) Sold under our Money Back Guarantee. Dealers everywhere. 25c.—50c.—

Crate - Fattened Poultry

We are open for shipments of crate-fattened poultry of all kinds. Highest market prices paid, according to quality. Prompt returns. Write us for quotations.

Henry Gatehouse & Son
348 Dorchester Street West
MONTREAL

POULTRY AND EGGS

Condensed advertisements will be inserted under this heading at three cents per word each insertion. Each initial counts for one word and figures for two words. Names and addresses are counted. Cash must always accompany the order for any advertisement under this heading. Parties having good pure-bred poultry and eggs for sale will find plenty of customers by using our advertising columns. No advertisements inserted for less than 50 cents.

BRED-TO-LAY Strain—White Leghorn cockerels, one dollar each. Brahmas, Spanish, Giant Bronze turkeys, Indian Runner ducks, bred from winners at London, Ottawa, Hamilton, Detroit. John Annesser, Tilbury, Ont.

EXTRA fine pure-bred bronze turkeys for sale at very low prices. Grand birds bred from stock of Guelph and Ottawa winners, all ages. Old customers come back for more. Wm. T. Ferguson, Spencerville, Ontario.

PRIZEWINNING, bred-to-lay stock—Two White Wyandotte cocks and choice cockerels. Choice White Rock cockerels and Fawn and White Indian Runner drakes. One-fifty each. George Buttery, Strathroy, Ont.

FOR SALE—Mammoth Bronze turkeys, bred from prizewinning stock; also purebred Collie pups. R. G. Rose, Glanworth, Ont.

WHITE Wyandottes, (Martin strain) Prize Winners. Dunc. McTavish, Chesley, Ont.

Crown Bone Cutter
EASIEST, Fastest, Feed BEST MADE
fresh cut bone and get more Lowest
eggs, higher fertility. Also dry in Price
Bone, Grain, Fertilizer and Shell
Mills. All Sizes. Hand and Power. Write to-day for
Free illus. Catalog. WILSON BROS., Dept. 46 Easton, Pa.

Chickens Are 16 cents
We quote the following: Chickens, crate-fattened, alive, 13c., dressed, 16c. per lb.; chickens, good farm stock, alive, 11c., dressed, 14c. per lb.; chickens, under 6 lbs. a pair, alive, 10c., dressed, 13c. per lb.; turkeys, choice hens, alive, 17c., dressed, 20c. per lb.; turkeys, choice gobblers, alive, 16c., dressed, 19c. per lb.; turkeys, rough, alive, 11c., dressed, 14c. per lb.; geese, dressed, 12 1/2c. per lb.; ducks, alive, 9c., dressed, 14c. per lb.; fowl, over 5 lbs. and alive, 11c., dressed, 11c. per lb. Money returned same day as goods received.
Horace Waller, 700 Spadina Ave., Toronto

Lochabar Poultry Yards

Has a nice lot of Banded Plymouth Rocks, English Pencilled Indian Runner Ducks, Rouen Ducks, Toulouse Geese and M. Bronze Turkeys for sale. Pairs furnished not akin.

D. A. Graham, Wyoming, Ont.

BE SURE AND ASK FOR THE
Maxwell
Line of WASHERS, CHURNS, BUTTER WORKERS, FOOD CUTTERS, GAS ENGINES, etc. Write for Catalogue.
Maxwells Limited, St. Mary's, Ontario

Contains over 35% protein
Contains over 33% carbohydrate
Keeps all live stock healthy if fed daily
MAPLE LEAF OIL CAKE MEAL
WRITE TO-DAY FOR FREE SAMPLE & PRICES
THE CANADA LINSSEED OIL MILLS, LTD.
TORONTO & MONTREAL

weary sequence of monotonous events, it stands out as something too sacredly beautiful to trust to a pen.

For many days I walked like one in a dream. Of one thing I felt proud; I had given him my love unquestioningly, trustingly, not knowing anything beyond what he told me, that he could give me a good home. I went to him with absolute faith; and if he had been a clerk, earning a weekly stipend it would have been the same. When the truth developed, that he was really a very wealthy man, I felt an added wonder that he had chosen me. I was surprised that Elsie had not told of his wealth, but it was evidently a whim of his that this should be reserved as a surprise.

We have been married for five years, but the joy in my heart that I should be so blessed of women makes each day a fresh gift in my life. The other day I came down to our big living-room. A bowl of lovely flowers stood on the table where my husband sat reading while the light from a softly shaded lamp brought out the strong, kind lines of his face. I paused for a few moments on the stairway to take in the picture, then I hurried to his chair and threw both arms about his neck. I turned his face toward mine so that I could look into his eyes.

"What is it, dearest?" he asked.
"Tell me truly, Dick, how did you ever make up your mind to marry a homely little woman like me?"
"You must never say that again, sweetheart," he replied tenderly. "You could never be homely with that true woman's soul shining from your eyes. I think you're the most beautiful woman in the world."—Woman's Home Companion.

In a French Town.

THE CHANGES OF A YEAR.
(By Frederic C. Spurr, in the "Christian World," London.)

From the height where I am writing there can be seen at night the reflection in the sky of the terrific flashes which are belched from the cannon at the front. And when all is quiet here there comes now and then the dull boom following the explosion. In the place where I spent the whole of yesterday—miles from here—many hundreds of lads who are lying in weakness upon their hospital beds can hear more clearly than is heard here the boom of those self-same guns which yesterday deafened them upon the actual field of battle. Over here there is no illusion about the war; its vile and poisonous breath envelops everybody and everything.

The change between the atmosphere in England and the atmosphere in France begins to be felt at Folkestone. The quay at Folkestone is not the old-time quay I have known for so many years. There is absent from it the old bustle, the old crowd, the old excitement. For the first time in my experience the turbine steamer left Folkestone at the scheduled time. Generally there has been delay owing to the embarkment of baggage and merchandise. But upon this occasion there was little baggage and little merchandise. The few travellers were officials, or nurses, or doctors, bound for the base. Khaki was the prevailing color. In place of the old pleasure automobiles which were in former times swung upon the deck, there were Red Cross automobiles and great boxes all marked with the sacred red sign. Not a traveller appeared to be bent upon pleasure; all seemed intent upon serious business.

Midway across the Channel we passed a hospital ship bound for "home," carrying wounded men to a place of treatment or of convalescence. It causes a thrill to pass through one to behold, for the first time, this strange ship painted with the Red Cross upon its sides. And it was such a ship, and filled with wounded men, that the pirates sought to torpedo at the beginning of the war. There are some evil deeds that the world can never forget, and that was one of them.

It is not an easy matter to get into—, or to remain there. Special permission must be obtained from the War Office. An ordinary passport, vised for France, does not give the right to stop in—, to their chagrin. The passenger for

Paris may not roam at large. One soon learns that to remain within the war zone is to be subjected to many restrictions. It is not possible to move away from the town without special permission. At each exit from the city a cordon of soldiers is drawn across the road, and no person is allowed to pass it unless he has a special passport of the necessary color. I have motored a good many miles in this region, but always under strict rule. The most stringent precautions are necessary. Little wonder, then, that soldiers are warned by means of official announcements to beware of entering into conversation with strangers, no matter how engaging they may be.

In the daytime the life of this city differs little from what it was ordinarily before the war broke out. Within the barriers things move much as usual. Two or three things advertise the presence of something not quite normal. One is the presence of a mixed and numerous soldiery. British, French, and Belgian soldiers are found everywhere. A visitor, suddenly descending upon the town and knowing nothing of the war, might well suspect the presence of something unusual from this simple fact of the presence of hundreds of soldiers. Then there are the newspaper shops and the book shops, full of war literature and war pictures. The latter are very different from our war pictures at home. Here in France the Catholic atmosphere is over everything—picture postcards included. Armies are represented as protected by Jeanne d'Arc or the Sacred Heart of Jesus. The skies of these pictures are full of angels and saints. Soldiers are depicted wearing protective badges. The Cathedral of Rheims, in total ruins, shows Christ standing at the main porch and crying, "What have the demons done to My house?" On the other side, the secular pictures are such as the British are largely strangers to. The gargoyles of the ruined cathedrals are made to lend themselves to representations of the Kaiser and his minions in a manner that may easily be imagined.

It is at night, however, that the difference is most clearly seen. At sunset the tram-cars cease running and the shops are closed. Cafes and hotels alike close their doors. There is no open drinking. The streets are plunged into a profound darkness. Every blind is drawn. No shaft of light must illuminate the pavement. Scarcely a sound is heard. Of laughter there is none. The kinemas have ceased to be. All the theatres are closed. The casinos are converted into hospitals—at night is a city of the dead. The war has entered, like iron, into the soul of this people. In company with Captain Chaplain Hughes I made a tour of the city within and without the walls after dark. It was a weird experience. In places we could not see a step before us. Passing into the old city we traversed the great square, skirted the buildings of the Hotel de Ville, and reached the Basilica. Not a person was abroad. The city within the walls lay around us as if smitten with the plague. Then, mounting a stone stairway, we gained the wall, and lay at our feet. Little could we see of it. The lights near the harbor alone gave us any indication of our locality. Then, as we remained contemplating the weird spectacle, there flashed out across the sea some powerful searchlights. While the men remained indoors and the city was plunged in darkness the Navy kept its unceasing vigil.

Hard by the Chateau, as we descended, we beheld the silhouettes of two figures outlined against the sky. A moment later there rang out on the night air the full pure tenor voice of a Scotsman singing "Annie Laurie." We could not see the face of the singer, nor did he reply to our salutation, but as was, without doubt, one of the many professional singers and musicians who have answered the call of their country. One of the chief bass singers of Becham's Opera, is here, while any day Mr. Kennerley Rumford may be seen driving his Red Cross motor car. I have had pointed out to me a wealthy titled man who is serving as a private in the Army. The son of one of the best-known noblemen in England is also here, an ordinary soldier.

WANTED FOR SALE

Advertisements will be inserted under this heading, such as Farm Properties, Help and Situations Wanted and Pet Stock. Each initial counts for one word and figures for two words. Names and addresses are counted. Cash must always accompany the order. No advertisement inserted for less than 50 cents.

FOR SALE—Two Scotch collie pups, one sable and one blue-mural, \$3 each. V. C. McNeill, R.R. No. 3, Wyoming, Ont.

FERRETS—Either color, large or small, single pairs or dozen lots. Catalogue free. C. H. Keefer & Co., Greenwich, Ohio.

WANTED—Experienced single man by year, dairy farm, must be good milker, temperate. A. O. Haist, Fenwick, Ont.

15 ACRE FARM FOR SALE—Dairy, fruit and vegetables; good buildings, silo. Small cash payment. Box 10 "Farmer's Advocate" London.

Beaver Hill Aberdeen-Angus—Bulls fit for service. Females all ages. Cows with calves at foot. Prices reasonable. ALEX. MCKINNEY, R.R. No. 1, Erin, Ontario. Cheltenham, G. T. R. Erin, C. F. R.

For Sale—One hundred and six 50-pound cases of evaporated apples. Apply WM. WEIDMILLER, Jr., Greenock, Ont. R. R. No. 1

Cedar Posts Car Lots Green 4 1/2 ins. under by 8 ft. 18c., 7 ins. and up by 9 ft., 22c. All bargains. Terms—Cash. Stamps for replies. Box 52, Gooderham Ont.

GET A BUSINESS TRAINING Complete Commercial Course taught you thoroughly by mail at home. Write Canadian Correspondence College, Limited Dept. EE, Toronto, Canada

Reid Bros., Bothwell, Ontario, Canada, Pioneer Breeders of and Dealers in High Grade Silver Black Pines for breeding purposes. A press-acknowledged industry, yet in its infancy, and full of wealth. Address as above.

He did not trouble about a commission. Has England ever known anything like this before? And afterwards, can it ever be the same country again?

I turned into a number of the churches, always to discover that they were crowded to the doors whenever a service was announced. At ten o'clock on a Thursday morning one big church was filled. At eight o'clock on the same night it was packed. I looked in at various churches during the daytime and never failed to find scores and sometimes hundreds of people kneeling down to pray. There is no priest visible nor is any required. The people come in from market-place and shop for a few minutes to pray. They then resume their occupations. Before the war I am told the churches were indifferently attended—people did not care about religion. All is now changed. A new spirit has come to France. The nation has recovered its dying soul. And somehow I cannot help recalling that prayer-meeting at the City Temple which fizzled out for want of support. England has not felt as France has felt, and England does not pray as France prays.

With mingled feelings we visited the cemetery. In that God's acre lie the bodies of more than 2,000 men fallen in the war. On one side lie the Frenchmen, on the other the British. There they rest, three bodies in each grave. There are no names inscribed, and there is but one tombstone. A white cross containing three numbers surmounts each grassy mound. A sergeant has the responsibility of caring for this precious parcel of ground, sacred in very truth. He performs his task nobly. The graves are beautifully kept. Let the mothers at home know that their sons who lie here repose amid beautiful surroundings and that their graves are guarded with jealous care. In a corner are 60 graves in which lie the bodies of Germans. Natural grass grows over them. No loving hand of wife or sweetheart or mother will ever plant a flower upon these graves. Enemies upon the battlefield, British and Germans here lie in the untroubled immobile neighborliness of death. How greet each other their souls in the Spirit world, these who on the battlefield were slain?

Outside the cemetery, in full view of this long line of graves, I suddenly dropped across a touch of comedy. It is a kitten, fat and furry, madly rushing around after its tail. And yonder are the graves of murdered men. Of these the kitten knows nothing—which thing is a parable of life.

"Pincher."

A DOG OF WAR WHO NEVER BARKED.

(The "Daily Mail," London.)

"A dog and a soldier are always friends" is a very old aphorism, but the owner of the "walrus"—for that was what Pincher, a diminutive spaniel of the King Charles variety, looked like when I saw him in England—had not always been a soldier. Many years of his life had been spent in the Australian bush, and a bushman and his horse and dog are boon companions.

The little spaniel, with some other four-footed creatures, had known a kind mistress; but when that lady, who happened to be wintering in Egypt, visited the camp of the Australian Expeditionary Force at Maadi, for some reason known only to himself he suddenly transferred his affections to Sergeant Tom Borlase, of the 7th New South Wales Light Horse. Accepting the inevitable, his mistress graciously gave the dog to the soldier and the two soon became firm friends.

Something like a knotty and nasty problem faced this hero, however, when a few weeks later his company received orders to proceed to the Dardanelles. Army regulations do not permit of a dog accompanying a soldier to the trenches, for obvious reasons. What was to be done? The sergeant did not mean to part with the spaniel. That which he had discovered concerning the wee fellow had not been imparted to anyone else. It was not the first time Borlase had been in a tight corner.

Nobody saw Pincher jump ashore at Gaba Tepe, but you can take it from me that he was with the veteran Australian when that memorable landing took place. Furthermore, although invisible, he was in the van.

Outside of his master's immediate comrades and chums there were not many who knew of Pincher's presence in the trenches. From the outset the spaniel seemed to realize what was expected of him—indeed he would scent danger quicker than most of his men and promptly hide himself. When trouble threatened otherwise Borlase and merely to cover him up with anything that was available, and there the faithful creature remained until he was released, no matter what the length of time might be.

One of the first to detect Pincher was Major W—, who held the sergeant in high esteem and in camp had shown a marked partiality for his pet.

"You will have to get rid of him, Tom, or you will get me into trouble, you know," he said, shaking his head. "If ever you hear him make a sound or show himself on top you can kill him forthwith, sir," was the reply. "He was never known to bark since I had him, and I will stake my life that he never does."

The weeks went by and they found the soldier and the spaniel inseparable, but all the officers were not as kindly disposed as the major. Another of them had apparently caught a glimpse of the dog, for Borlase was "warned" to get rid of Pincher, and to all intents and purposes the spaniel vanished.

Subsequently an order for the removal of the dog was conveyed to the sergeant, and the search party, which was most assiduous in its efforts to locate Pincher, elicited a sad fact.

"You needn't worry," said Borlase, with a glum face, "the poor little wretch is in his grave." The search party did not know then that it was only a temporary grave.

It may have been a week afterwards that Tom was sharing a meal with Pincher when an officer unexpectedly arrived on the scene. Quick as Pincher and his friend were their movements did not escape the eyes of the captain, and it was with a sad heart that the sergeant awaited the official arrest of his dog.

"No other animal has been so much in orders," remarked the colonel when the resurrection of Pincher had been reported to him, and that night the dread fat went forth. The spaniel was condemned to death on the morrow. Long before the morning, however, the approach of the "warrant" was heralded in that mysterious manner so well known among military men, and from

Dainty Bedroom Pieces Low Priced

This dresser or chiffonier may be had in either fumed oak or white enamel at the prices quoted. Both have high-class finish and interior construction. They are examples of the splendid values contained in our large illustrated

Catalogue No. 7 which we will be glad to send to anyone upon request. We pay freight charges to any station in Ontario.

The ADAMS Furniture Co., Limited
TORONTO, ONT.



\$15.75



\$16.95

WE WANT—

CREAM

We offer highest prices for churning cream. Write us for quotations.

SANITARY DAIRY
H. W. Newhall, Mgr. ST. CATHARINES

CREAM! Mr. Shipper, Attention!

Reasons why you should send your cream to us:

1. We aim to pay the highest prices.
2. We give you a square deal.
3. We have the largest market in Ontario.
4. We are prompt in making remittances.

The market indicates a gradual advance. Act now. Write us for further particulars.

THE TORONTO CREAMERY CO., LIMITED
9 Church Street, Toronto

FREE! Let Us Send You This New Book of Valuable BARN Facts!

Send No Money! Write today for Free Copy! Mail Coupon or Postal

Cut Your Barn Work in Half and Boost Your Dairy Profits

Cleaning the barn with a wheelbarrow is the dirtiest, most disagreeable and hardest work on the farm. It's a job that's shirked by hired men, boys and owners as often as possible. It's a job that tries "men's souls." It's a task that drags the profession of Farming down to the point where it's next to impossible to keep good help—and almost a sin to keep boys at home. And your barn rots, your cows suffer and your profits suffer, if the work isn't done *regularly and thoroughly*. It's costly, wasteful, disagreeable, behind-the-times, and unnecessary. *Stop it!*

This Free Book Tells How

It shows just how a Dillon Manure Carrier makes and saves money for you—how it saves work and time. It quotes a price that saves you money at the start. It offers to send you a Dillon for 60 days to try in your own barn. It shows why no carrier can compare with it regardless of price. These things, and many others are fully and completely gone into in our book.

Write Us Today

Just send us your name and address on the coupon below or on a postal. We want 5,000 farmers and dairymen to write for this book and special price offer. We will show you how to cut out the back-breaking work of cleaning the barn and will make it easy for you to get a Dillon. Don't wait—don't put this off—get our book now by sending us your name. Remember, the book is free.



Just send us your name and address. We will mail you a book you'll be mighty glad you wrote for. It tells how the most progressive farmers and dairymen in the Dominion are keeping their barns cleaner, with less work, in less time—how they are making more money—how they are keeping their stock healthier, and it tells and shows how you can do it. It points out the reasons for the successful dairyman's success. It tells these things and many more in such a simple, easy-to-understand way that you cannot fail to benefit by reading this book. Write for your copy today. It is free—with our compliments.

The New Way To Clean Barns

This free book illustrates and describes how the Dillon Carrier makes play out of barn cleaning—how it cuts the work into less than half—how it saves time, preserves all the valuable liquid manure for your land, keeps the barn clean so cows don't live in filth, don't breathe disease, and milk isn't contaminated. It shows how the Dillon Carrier keeps manure away from barn—no disagreeable odor, no rotting boards, no weak eyes or lungs. These are a few of the ways a Dillon Manure Carrier saves work, time and money and adds to your profits. They are all told about in our new fine book which we want to send you free. Mail coupon or just a postal now.

Get this book—then let us send you a Dillon Manure Carrier direct from factory, on 60 days' trial—freight prepaid, or partly paid according to locality and we save you big money on price if you decide to buy.

The Dillon Manure Carrier is made so we can afford to send it to you on the most liberal selling plan ever devised. The tub holds 12 bushels, is all steel, every part of it, ends too, heavily galvanized and angle braced. Rises and lowers with a little pull on the chain. Friction clutch brake keeps it from coming down too fast. Overhead track made of high carbon steel, yet easily bent cold for curves. Easily hung with our hangers, adjustable for uneven heights in barn. Double-wheel trucks and double-wheel track makes tub run smoothly and couplings never part; Safety Stop Switches prevent accidents and never fail; Outside Swing Pole and patented Outside Track Hinge are exclusive features that place the Dillon far ahead of all others—fully explained in our free booklet.

Mail Coupon or Postal TODAY Get Our Price and New Book Free

We save you big money on the first price by selling direct from factory and guarantee you the best outfit money can buy. We have been in the barn hardware business for 25 years, right here in Oshawa and do everything we claim. Get our price and our booklet. Read what our customers say. Try a Dillon—return it if you are not completely satisfied in every way. Send coupon or postal now—before you forget—for our book and money saving price. Please mention number of cows you keep. For your own sake, don't turn this page before you write us. Do it now.

R. DILLON & SON
412 MILL STREET
SOUTH OSHAWA, ONT

MAIL THIS COUPON NOW

Free Coupon For Dillon Manure Carrier Book

Name _____

Address _____

R. DILLON & SON
South Oshawa, Ontario
412 Mill Street

FOUNDED 1866

WANTS FOR SALE

Advertisements will be inserted under this heading, such as Farm Properties, Help and Positions Wanted and Pet Stock. Help and Positions Wanted—Three cents per word each insertion. Initial counts for one word and figures for two words. Names and addresses are counted. Cash must always accompany the order. No advertisement inserted for less than 50 cents.

FOR SALE—Two Scotch collie pups, one sable and one blue-mural, \$3 each. V. C. McNeill, R. No. 3, Wyoming, Ont.

PERRETS—Either color, large or small, single pairs or dozen lots. Catalogue free. C. H. Fisher & Co., Greenwich, Ohio.

WANTED—Experienced single man by year, dairy farm, must be good milker, temperate. A. O. Haist, Fenwick, Ont.

5 ACRE FARM FOR SALE—Dairy, fruit and vegetables; good buildings, silo. Small cash payment. Box 10 "Farmer's Advocate" London.

Heaver Hill service. Females all ages. Cows and calves at foot. Prices reasonable. W. J. McKINNEY, R.R. No. 1, Erin, Ontario. Cheltenham, G. T. R. Erin, C. P. R.

For Sale—One hundred and six 50-pound cases of evaporated apples. Apply W. M. WEIDMILLER, Jr., R. No. 1 Greenock, Ont.

Red Posts Car Lots Green 4 1/4 ins. under 7 ins. by 8 ft. 9c. 7 ins. and up 8 ft. 18c. 7 ins and up by 9 ft. 22c. All bars. Terms—Cash. Stamps for replies. Box 52, Gooderham Ont.

GET A BUSINESS TRAINING Complete Commercial Course taught you thoroughly by mail at home. Write Canadian Correspondence College, Limited Dept. E.E., Toronto, Canada

Reid Bros., Bothwell, Ontario, Canada, Pioneer Breeders of and Dealers in High Grade Silver Black Faxes for breeding purposes. A press-acknowledged industry, yet in its infancy, and full of wealth. Address as above.

did not trouble about a commission. England ever known anything like this before? And afterwards, can it be the same country again? I turned into a number of the churches, always to discover that they were crowded to the doors whenever a service was announced. At ten o'clock on a Thursday morning one big church was filled. At eight o'clock on the next night it was packed. I looked in various churches during the daytime and never failed to find scores and sometimes hundreds of people kneeling down in prayer. There is no priest visible nor any required. The people come in from market-place and shop for a few minutes to pray. They then resume their occupations. Before the war I attended the churches were indifferently attended—people did not care about religion. All is now changed. A new spirit has come to France. The nation recovered its dying soul. And some-thing I cannot help recalling that praying at the City Temple which fized for want of support. England has felt as France has felt, and England does not pray as France prays. With mingled feelings we visited the cemetery. In that God's acre lie the bodies of more than 2,000 men fallen in the war. On one side lie the French, on the other the British. There are three bodies in each grave. There are no names inscribed, and there is only one tombstone. A white cross standing three numbers surmounts a grassy mound. A sergeant has the responsibility of caring for this precious spot of ground, sacred in very truth. He performs his task nobly. The graves are beautifully kept. Let the mothers know that their sons who lie in repose amid beautiful surroundings that their graves are guarded with the same care. In a corner are 60 graves which lie the bodies of German-soldiers grass grows over them. No lovest hand of wife or sweetheart or mother will ever plant a flower upon these graves. Enemies upon the battlefield, British and Germans here lie in untroubled immobile neighborliness. How greet each other their spirits in the Spirit world, these who on the battlefield were slain? Outside the cemetery, in full view of a long line of graves, I suddenly drop a touch of comedy. It is a kit-bag fat and furry, madly rushing around its tail. And yonder are the bodies of murdered men. Of these the man knows nothing—which thing is a little of life.

10 Days Free Trial *Charges Prepaid*
Send No Money

TWICE THE LIGHT **HALF THE OIL** **NEW COAL OIL LIGHT**
Beats Electric or Gasoline

We don't ask you to pay us a cent until you have used this wonderful modern light in your own home ten days—we even prepay transportation charges. You may return it at our expense if not perfectly satisfied after putting it to every possible test for 10 nights. You can't possibly lose a cent. We want to prove to you that it makes an ordinary oil lamp look like a candle; beats electric, gasoline or acetylene. Lights and is put out like old oil lamp. Tests at 33 leading Universities and Government Bureau of Standards show it

Burns 70 Hours on One Gallon

common coal oil, and gives more than twice as much light as the best round wick open flame lamps. No odor, smoke or noise, simple, clean, no pressure, won't explode. Several million people already enjoying this powerful, white, steady light, nearest to sunlight. Guaranteed.

Awarded GOLD MEDAL at World's Exposition San Francisco

\$1000 Will Be Given to the person who shows us an oil lamp equal to the new Aladdin (details of offer given in our circular.) Would we dare make such a challenge if there were the slightest doubt as to merit of the Aladdin? We want one user in each locality to whom we can refer customers. Be the first and get our special introductory offer under which you get your own lamp free for showing it to a few neighbors and sending in their orders. Write quick for 10-Day Absolutely Free Trial. Send coupon to nearest office.

MANTLE LAMP COMPANY, 222 Aladdin Bldg.
 Largest Kerosene (Coal Oil) Mantle Lamp House in the World. Montreal, Can. Winnipeg, Can. P.O. Address.....

Men Make \$50 to \$300.00 Per Month With Rigs or Autos
 delivering the ALADDIN on our easy trial plan. No previous experience necessary. Practically every farm home and small town home will buy after trying. One farmer who had never sold anything in his life before writes: "I sold 61 lamps the first seven days." Another says: "I disposed of 87 lamps out of 81 calls." Thousands who are coining money endorse the Aladdin just as strongly.

NO MONEY Required
 We furnish capital to reliable men to get started. Ask for our distributor's plan, and learn how to make big money in unoccupied territory. Sample sent for 10 days FREE TRIAL.

10-DAY FREE TRIAL COUPON
 I would like to know more about the Aladdin lamp and your Easy Delivery Plan, under which I can get my own lamp free for showing it to a few neighbors and sending in their orders. Write quick for 10-Day Absolutely Free Trial. Send coupon to nearest office.

PAINTED WALLS

Cleaned in a Jiffy When You Use

Large Sifter Can, with Full Directions, 10c

Old Dutch Cleanser

Chases Dirt

MAKES EVERYTHING SHINE AND LAST

The Dick Hand Cutting Box

Is the fastest and easiest turned box on the market. A 1 1/2 h.p. gasoline engine will run it nicely. Our prices will surprise you. Write for full particulars and Illustrated Catalogue.

THE DICK AGRICULTURE WORKS
 Bolton, Ontario

When Writing Please Mention Advocate

scores of friends whom Pincher had by this time made a message was passed back along the lines to the effect that a large number of Australians would have to go before the dog went. But notwithstanding this defiance of devotion everything presaged that "in accordance with instructions issued" the "walrus" would pass away at noon next day.

"I am afraid that is final, Tom," observed the major when he happened to come along; "I can't do anything more for him."

There was a long pause. Borlase was too downhearted to speak.

"You must tax your ingenuity again," added the major sympathetically as he moved off.

Although Sergeant Tom Borlase was destined in more ways than one to fire his last shot that day, as yet he had not done so. Suddenly an inspiration occurred to him, and the coast being clear he scuttled off along the trench. When he returned a few minutes later he had parted with Pincher, and in response to the N. C. O. who soon appeared with the warrant, he was able to take his Colonial oath that the dog had gone.

It certainly seemed as if the little spaniel had been a "mascot" to Borlase when two hours later a shell burst over the trench and a piece of shrapnel lodged in the sergeant's left hip. As speedily as possible he was conveyed to the clearing hospital, whither a trusty friend brought him a bundle of some sort just prior to his being put on board a mine-sweeper and taken to the hospital ship which was to carry him to Malta.

Badly wounded as he was Borlase clung tenaciously to that bundle, one end of which had soon worked open, and disclosed the brown indiarubber nose and quaint little face of Pincher.

It matters little how the spaniel and the Spartan reached England. One of the first things incumbent upon a patient entering a military hospital in England is to discard his clothing for the regulation dress, the whole of his kit being sent to a pack store until such times as he may be fit to receive it again.

When the stretcher bearers had deposited Borlase in bed and the process of changing his apparel was about over, the sister on duty in the hut-ward came along, and perceiving his great-coat, which had apparently fallen to the floor, stooped to pick it up, she was, to say the least, quite startled at seeing a slender brown and white spaniel drop out of its folds.

"Don't let them take him away, sister," pleaded Borlase; "he's been right through with me, and you'll never find him a bit of trouble I promise you." And Pincher, jumping on the coverlet, extended a tan forepaw and said, "Shake!" What nurse could have resisted such an appeal as that?

Training Children.

Editor "The Farmer's Advocate" and Home Magazine:—

No other effort is so richly repaid as the training of a little child. In the first six years the mother, if she will, may lay the foundations for a strong, beautiful character.

It is all-important to begin in the early formative period. In the first and second years the little one should learn the lesson of obedience. As soon as it can understand, teach it, in games and real life, to practice kindness, helpfulness, fair play and other virtues. Often suggest to it, very earnestly and confidently, that it can and will be noble, unselfish, good and true. Praise it when it tries to do right. Read to it stories containing moral lessons. Above all, remember that example is more potent than precept. Like excites like. Love, encouragement and praise inspire the best in the child; scolding and harsh treatment aggravate the worst elements in its nature.

The mother's golden opportunity to implant noble, inborn talents and tendencies is the sacred time before the birth of her babe, when its forming mind and soul are plastic to the impress of her mental and spiritual forces. If she will cherish only beautiful, kindly, happy thoughts and aspirations, and an all-absorbing desire or prayer that the coming little one may

be lovely, pure and good, experience proves that it will almost certainly be so.

Russian Fairy Tales.

THE TWO HERMITS.

Translated by Stephen Graham from the Russian of Solovyof.

In the desert of Nitria in Egypt two hermits were saving their souls. Their caves were quite near one another, but they never entered into conversation unless it were to sing psalms to one another or call one another by name now and then. In this way of life they passed many years, and the fame of their sanctity spread beyond Egypt and into many lands. But in course of time the devil, mortified by their holiness, succeeded in tempting them. He snared them both at the same time, and, not saying a word to one another, they gathered the baskets and pallets which in their long spare time they had plaited from grasses and palm leaves and they set off together for Alexandria. They sold their work, and on the money they got for it they spent three gay days and nights with drunkards and sinners, and on the fourth morning, having spent everything, they returned to their cells in the desert.

One of them wept bitterly and howled aloud. The other walked at his side with bright morning face and sang psalms joyfully to himself. The first cried:

"Accursed that I am, now am I lost for ever. I shall never outpay my hideous sin, never, never. All my fasts and hymns and prayers have been in vain. I might as well have sinned all the time. All lost in one foul moment! Alas! Alas!"

But the other hermit went on singing, quietly, joyfully.

"What!" cried the first hermit.

"Have you gone out of your mind?"

"Why?" asked the joyful one.

"Why don't you repent?"

"What is there for me to repent of?"

asked the joyful one.

"And Alexandria; have you forgotten it?" asked his companion.

"What of Alexandria? Glory be to the Almighty who preserves that famous and honorable town!"

"But what did we do in Alexandria?"

"What did we do? Why, we sold our baskets, of course, prayed upon the ikon of holy St. Mark, visited several churches, walked a little in the town hall, conversed with the virtuous and Christly Leonila—"

The repentant hermit stared at the other in pale stupefaction.

"And the house of ill fame in which we spent the night?" said he.

"God preserve us!" said the other.

"The evening and night we spent in the guest house of the patriarch."

"Holy martyrs! God has already blasted his reason," cried the repentant hermit. "And with whom did we get drunk on Tuesday night? Tell me that."

We partook of wine and viands in the refectory of the Patriarchate, Tuesday being the festival of the Presentation of the Most Blessed Mother of God."

"Poor fellow! And whom did we kiss, eh?"

"We were honored at parting with a holy kiss from that father of fathers, the most blessed archbishop of the great city of Alexandria and of all Egypt; yes, and of Libya, and of Pentapolis and of Kur-Timothee with its spiritual court and with all the fathers and brothers of his divinely appointed clergy."

"Ah, why do you make a mock of me? Does it mean that after yesterday's abominations the devil has entered into possession of you? You embraced sinners, you accursed one!"

"I can't say in whom the devil has found a home, in me or in you," said the other: "in me when I rejoice in God's gifts and His holy will. When I praise the Creator and all His works; or in you who rave and call the house of our most blessed father and pastor a house of ill fame and defame the God-loving clergy, calling them sinners, as it were."

"Ah, you heretic!" screamed the repentant hermit. "Arian monster! Thrice accursed lips of the abominable Apollonion!"

And the repentant hermit threw himself upon his companion and tried to

kill him. But grow tired of resumed their The repentant rock all night made the des and shrieks. fully went on

In the morn made the foll think of it. special blessing fasts and my Russian word tories, especial a denial of the ready become and wonders I to perform, but pemed, all is lo to fleshly aboi against the Ho according to th forgiven me no the life to com pearl of heaven under feet by devils have to doubt, having c they will come Well, well; if whatever is the in the desert? Alexandria and life of debauch occasion when spired with oth a rich merchant him. He was tried in the e demned him to out repentance.

But his old c holy life, his po of going on do tinuance of deni a high degree famous throug wrought at his from his holy l age of child-bea brought forth a last the good n and worn out b blossomed in be ing translucent a heavenly pe relics a monaste name went forth Alexandria to B the shrines of K The lesson of to Barsonophia, are no sins of despondency. D mits sin alike, a was lost, namely Barsonophia w Athos who used grieve about you them; they don't in a day, but that's the chief evil, then to There is nothing mind one's own only one deadly spondency; from spair that is spiritual death."

Fine Distinctio been very tryin ing, when her gro ting her to bed, the child would tomorrow, and no happy with her n Molly listened in for a few moment ly: "Yes, when it's it's you it's nerv

A colored man c looking for work. "What is your n hiring him. "Mah name is I answer. "Poe!" she excl of your family w Poe; did they?" The colored man with amazement. "Why—why, ma's pointed a dusky fi Ah am Edgah A cott's.

vely, pure and good, experience that it will almost certainly be F. M. O.

Russian Fairy Tales.

THE TWO HERMITS.
ated by Stephen Graham from the Russian of Solovyo.

In the morning the repentant hermit made the following reflections: "Just think of it. I had earned from Heaven special blessings and holy power by my fasts and my podvigs."

But his old companion continued his holy life, his podvzhnitchestvo (the life of going on doing podvigs, the continuance of denial of the world), attained a high degree of sanctity and became famous through the many miracles wrought at his cave-mouth.

The lesson of this story is, according to Barsanophia, who told it, that there are no sins of any importance except despondency. Did not both these hermits sin alike, and yet but one of them was lost, namely, he who desponded.

Barsanophia was a pilgrim from Mount Athos who used to say: "Eh, eh, don't grieve about your sins, be done with them; they don't count. Sin 439 times in a day, but don't grieve about it; that's the chief thing. If to sin is evil, then to remember sin is evil. There is nothing worse than to call to mind one's own sins. . . . There is only one deadly sin, and that is despondency; from despondency comes despair that is more than sin; it is spiritual death."—Country Life.

Fine Distinction.—Little Molly had been very trying all day. That evening, when her grown-up sister was putting her to bed, she said she hoped the child would be a better girl tomorrow, and not make everybody unhappy with her naughty temper.

Molly listened in silence, thought hard for a few moments, and then said, wisely: "Yes, when it's me it's temper; when it's you it's nerves."—Tit-Bits.

A colored man called at Mrs. Baxley's looking for work. "What is your name?" she asked, after hiring him. "Mah name is Poe, ma'am," was the answer.

"Poe!" she exclaimed. "Perhaps some of your family worked for Edgar Allan Poe; did they?"

The colored man opened his eyes wide with amazement. "Why—why, ma'am," he said, as he pointed a dusky finger at himself—"why, Ah am Edgah Allan Poe!"—Lippincott's.

kill him. But failing to do that, he grew tired of his efforts, and the two resumed their journey to their caves. The repentant one beat his head on the rock all night and tore his hair and made the desert echo with his hoys and shrieks. The other calmly and joyfully went on singing psalms.

In the morning the repentant hermit made the following reflections: "Just think of it. I had earned from Heaven special blessings and holy power by my fasts and my podvigs."

But his old companion continued his holy life, his podvzhnitchestvo (the life of going on doing podvigs, the continuance of denial of the world), attained a high degree of sanctity and became famous through the many miracles wrought at his cave-mouth.

The lesson of this story is, according to Barsanophia, who told it, that there are no sins of any importance except despondency. Did not both these hermits sin alike, and yet but one of them was lost, namely, he who desponded.

Fine Distinction.—Little Molly had been very trying all day. That evening, when her grown-up sister was putting her to bed, she said she hoped the child would be a better girl tomorrow, and not make everybody unhappy with her naughty temper.

Molly listened in silence, thought hard for a few moments, and then said, wisely: "Yes, when it's me it's temper; when it's you it's nerves."—Tit-Bits.

A colored man called at Mrs. Baxley's looking for work. "What is your name?" she asked, after hiring him. "Mah name is Poe, ma'am," was the answer.

Opportunity.

They do me wrong who say I come no more
When once I knock and fail to find you in;
For every day I stand outside your door,
And bid you wake and rise to fight and win.

Wail not for precious chances passed away;
Weep not for golden ages on the wane;
Each night I burn the records of the day;
At sunrise every soul is born again.

Laugh like a boy at splendors that have sped,
To vanished joys be blind and deaf and dumb;
My judgments seal the dead past with its dead,
But never bind a moment yet to come.

Though deep in mire, wring not your hands and weep;
I lend my arm to all who say "I can!"
No shame-faced outcast ever sank so deep
But yet might rise and be again a man.

Dost thou behold thy lost youth all aghast?
Dost reel from righteous retribution's blow?
Then turn from blotted archives of the past
And find the future's pages white as snow.

WALTER MALONE.

Our Serial Story

"THE CHAPERON."

By C. N. and A. M. Williamson.

Copyrighted.

Chapter XXV.

PHYLLIS RIVERS' POINT OF VIEW. (Continued.)

That was the way it happened that we had two nights at Enkhuisein; but the second we spent on "Lorelei-Mascotte" and "Waterspin," sleeping on the boats for the first time, and it was great fun. The next morning early, we had a picnic breakfast on board, making coffee with the grand apparatus in Mr. Starr's wonderful tea-basket, which he had bought at the most expensive shop in London, like the extravagant young man he is.

When we had arrived it was hard to realize that Stavoren had once been a place of vast importance, and that a powerful king had lived there in old, old days, for the bastion seemed the only thing of importance in the poor little town now. But no doubt the great sand-bank, with its famous legend of the Proud Lady, is enough to account for the decline.

Nell smiled in a naughty, mischievous way, when her cousin remarked that his mother's family came originally from Friesland, I suppose because Jonkheer Brederode had just told us that the Frisian people are the most obstinate and persistent in the Netherlands: that all the obstinacy in any other whole province would not be as much as is contained in one Frisian man—or woman. But I think they have reason to be proud of themselves, especially as their obstinacy has kept their ancient customs and language almost intact, and the Spaniards never could make the least impression upon them by the most original and terrific kinds of tortures, invented especially to subdue Frisians. If they were buried alive, they just went on smiling, and saying, "I will," or "I won't," until their mouths were covered up.

I almost wished that Jonkheer Bre-

CALDWELL'S
If you believe in
right feeding
send this in

It will pay you to know all about these famous lines, that are Government-guaranteed and used by the biggest men in the business.

- "Caldwell's" Molasses Meal
"Caldwell's" Molasses Horse Feed
"Caldwell's" Alfalfa and Molasses Horse Feed
"Caldwell's" Molasses Dairy Meal
"Caldwell's" Dry Dairy Meal
"Caldwell's" Cream Substitute Calf Meal
"Caldwell's" Poultry Laying Meal
"Caldwell's" Poultry Scratch Feed
"Caldwell's" Chick Feed
"Caldwell's" Growing Mash
"Caldwell's" Developing Feed

Mark tick in squares opposite feeds you are interested in. Sign your name and address, then tear out the ad. and send it to us. This puts you under no obligation. By return mail you will receive some profitable booklets, free. Do it now while you think of it.

Name
Address

THE CALDWELL FEED & CEREAL CO., Ltd., Dundas, Ont.

STANDARD FEEDS

Big Drop in Prices of
FURS AND FUR
GARMENTS

No matter where you live or what you or your family want in Furs, or Fur garments, you can buy cheaper and better by dealing direct with us.

It will pay you to send for our Fur Style Book, 1915-16 edition, SENT FREE on request which contains 34 Pages of illustrations of beautiful furs, and will tell you how you can buy cheaper and better from us under our system of

No. 112
Muskat
Coat
\$34.50



112—MUSKRAT COAT to match above coat, in large pillow shape, silk lined, down bed and wrist cord.

No. 113
Muff to
Match
\$5.50

FROM TRAPPER TO WEARER

When you realize that we are the largest cash buyers of Raw Furs in Canada, purchasing direct from the trapper, you will appreciate the unrivalled opportunity we have to select the finest skins, manufacture them into desirable Fur sets and Fur garments, then by selling direct by mail save you the middlemen's profits.

You will be astonished to see the beautiful Furs you can purchase from us for a little money, every one a gem in its class. This season furs are lower in price than ever before, owing largely to most of the European markets being closed on account of the war, but the stock of Raw Furs in America now is so low, that prices are stiffening up, and it looks to us as if they will advance steadily from now on. You should buy your furs this season without fail. Remember our Fur Style Book prices mean goods delivered to you, as

WE PAY ALL DELIVERY CHARGES.

Every article is sold under OUR POSITIVE GUARANTEE to "SATISFY YOU OR REFUND YOUR MONEY."

The furs illustrated here are taken from our Fur Style Book, and give you but a faint idea of the numerous bargains offered to you, which are shown in our Fur Style Book. Should the furs shown here meet with your approval, send us their price, and we will ship at once, delivery charges paid by us, and guaranteed to be satisfactory.

MUSKRAT COAT BLACK WOLF SET

112—The MUSKRAT COAT is This is a beautiful 40 inches long, made from evenly set made from long matched Muskrat skins in this hatched—good quality popular style. This coat is very—whole skins. The special value, well made in every side is cut extra deep and wide over shoulder good quality brown satin. Deep is trimmed with head and tail over shoulder and with large croch buttons and and warmly interlined. Price \$34.50

113—The BLACK WOLF SET is a beautiful 40 inches long, made from evenly set made from long matched Black Wolf skins in this hatched—good quality popular style. This set is very—whole skins. The special value, well made in every side is cut extra deep and wide over shoulder good quality brown satin. Deep is trimmed with head and tail over shoulder and with large croch buttons and and warmly interlined. Price \$32.00

114—The MUFF to match above coat, in large pillow shape, silk lined, down bed and wrist cord. Price \$5.50 No. 224, Stole... \$6.25 No. 225, Muff... \$6.50

No. 225
Muff
\$6.50
No. 224
Stole
\$6.25

Do not wait but send to-day to

John Hallam Limited

Room 209 Hallam Building, Toronto, Canada

WE ARE THE LARGEST CASH BUYERS OF RAW FURS IN CANADA.

You may be deceived some day by an imitation of "SALADA"

and possibly you will not detect this imitation until the tea-pot reveals it. Demand always the genuine "Salada" in the sealed aluminum packet, and see that you get it, if you want that unique flavour of fresh, clean leaves properly prepared and packed.

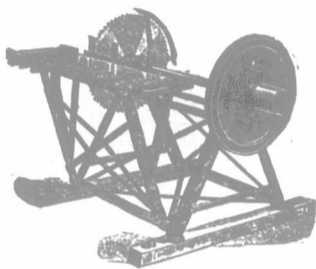

We Saw It First!

Large are the sales of our \$19.00 Wood Saw. We are the first makers of saws to discover the need of such a saw—and the first to supply such an article at such a price.

Selling direct to the farm, with no middleman's profit, it is but natural that we can get the prices on saws down pretty low. But the remarkable thing is, that we've been able to include so many splendid features in this low-priced saw. Here are a few of the outstanding ones:

Heavy angle steel bars, well braced and strongly bolted; A shaft box that is dust-proof and non-heating; Saw blade protected by heavy steel guard; Roller at one end of tilting table to facilitate handling long poles;

All this for \$19.00, with blades extra as follows:

20-inch.....\$3.25	26-inch.....\$5.25
22-inch.....3.85	28-inch.....6.05
24-inch.....4.45	30-inch.....6.85

Write for descriptive folder,—and at the same time, ask for our big free general catalogue.

THE PAGE WIRE FENCE COMPANY
LIMITED.

1137 King Street, West, Toronto

Itinerary for Movement of Exhibition Car

DECEMBER, 1915

Brampton	Dec. 1
Acton West	" 2
Guelph	" 3
Elora	" 4
Fergus	" 6
Drayton	" 7
Palmerston	" 8
Walkerton	" 9
Port Elgin	" 10
Southampton	" 11
Listowel	" 13
Brussels	" 14
Wingham	" 15
Kincardine	" 16
Milverton	" 17
Stratford	" 18
New Hamburg	" 20
Berlin	" 21
Elmira	" 22
Toronto	" 23

derode hadn't said, before Mr. van Buren, that a "Frisian head" is an expression used by the Dutch when they mean incredible hardness or obstinacy; but he didn't mind at all, and immediately told us a thing that happened to his mother and some Frisian cousins of hers when they were girls. A musical genius, a young man, was visiting at their house, and when he had played a great deal for them at their request, he made a bet that they would tire of hearing his music before he tired of making it. They took the bet and he began to play again; but he was not Frisian, and had never been in Friesland before, therefore he was not prepared for what would happen. Still, he was Dutch, so he did not like giving up, and he went on playing for twenty-four hours, without stopping for more than five minutes at a time. The ladies always exclaimed, "Please go on if you can; we're not tired at all," though they looked very pale and ill; so he didn't stop until he tumbled off his music-stool, and had to be carried away to bed, where he lay for two days. But the Frisian girls suffered no bad consequences, and said, if he had not given up, they would have sat, listening for at least a week.

Once Jonkheer Brederode had a big yacht which he lent to the Belgian king for a trip, and there was a Frisian skipper. Every morning the decks were washed at five o'clock, and the king sent word that he would be glad to have it done later in the day, as it waked him up, and he could not go to sleep again. Then the Frisian answered, "Very sorry, King, but we always do wash the decks at five, and it must be done"; which amused his majesty so much that he made no more objections.

If the people of Friesland have great individuality, so have their meers. There was a canal through which we had to pass after Stavoren, like a long green-walled corridor leading into a huge room. The green wall was made of tall reeds, and we had glimpses of level golden spaces, and sails which seemed to be skimming through meadows. There was a crying of gulls, a smell of salt and of peat, which once formed the great forests swallowed up by the meer. Then, through a kind of water-gateway, we slipped into our first Frisian meer, where the water was like glass, the black sails of yellow sail-boats were purple in the sunlight, and the windmills on the distant shore looked like restless, gesticulating ghosts.

Our wash raised a golden, pearl-fringed wave, but the water was so clear that now and then we fancied we could faintly see the old road under the meer, which they say Frisian farmers use to this day, knowing just where and how to guide their horses along it, through the water.

Because of this road, and others like it, Jonkheer Brederode had taken on a pilot at Stavoren, a man able to keep us off all hidden perils. He seemed to know every person on every heavily-laden peat-boat, or brightly painted eel-boat, and Nell insisted that even the families of wild ducks we met nodded to him as we went by.

We passed from the meer called Morra into the biggest in all Friesland, Fluesen Meer; and it was all rather like the Norfolk Broads, where my father once took me when I was a child. Always going from one meer into another, there were charming canals, decorated with pretty little houses in gardens of roses and hollyhocks, and emphasized, somehow, by strange windmills exactly like large, wise gray owls, or, in the distance, resembling monks bearing aloft tall crosses.

It was exquisite to glide on and on between two worlds; the world of realities, the world of reflections. Villages were far separated one from another, on canal and meer, though there were many farmhouses, walled round by great trees to keep cool the store-lofts in their steeply-sloping roofs. Gulls sat about like domestic fowls, and perched on the backs of cows, that grazed in meadows fringed with pink and purple flowers.

Men and girls rowed home from milking, and hung their green and scarlet milk-pails in rows on the outer walls of their farmhouse homes. Fishing-nets were looped from pole to pole by the water-side, in such curious fashion as to

look like vineyards of trailing brown vines; and as we drew near to Sneek, where we planned to stay the night, we began to meet quaint lighters, with much picturesque family life going on, on board; children playing with queer, homemade toys; ancient, white-capped dames knitting; girls flirting with young men on passing peat-boats—men in scarlet jerseys which, reflected in the smooth water, looked like burning fire under glass.

The old seventeenth-century water-gate at Sneek was so beautiful, that we expected to like the place with the ugly name; but after all we hated it, and decided to spend another night in our own floating houses.

All sorts of funny, water-noises waked me early; but then, I hadn't slept very soundly, because I couldn't help thinking a good deal about Mr. van Buren, who found a telegram waiting for him at Sneek, and went away from us by the first train he could catch. I don't know what was in the telegram, but he looked rather miserable as he read it, and I wondered a good deal in the night if his mother had called him back because Freule Menela van der Windt was not pleased at having him stay so long with us.

Nell thought our next day's run, going through the River Boorn to the Sneaker Meer, past Grouw and on to Leeuwarden, even more delightful than the day before; but it didn't seem as interesting to me, somehow. Perhaps it was having a person who was partly Frisian standing by me all the time, and telling me things, which made the difference; anyway, I had a homesick feeling, as if something were lacking. Mr. Starr said it would be nice to spend a honeymoon on board one of the nice little wherries we saw in the big meer; but I thought of Mr. van Buren and Freule Menela having theirs on one, and it gave me quite a sinking of the heart. I tried not to show that I was sad, but I'm afraid Mr. Starr guessed, for in the afternoon he gave me a water-color sketch he had made in the morning, on deck. He called it a "rough, impressionist thing," but it is really exquisite; the water pale lilac, with silver frills of foam, just as it looked in the light when he sat painting; fields of cloth-of-gold, starred with wild flowers in the foreground; far-off trees in soft gray and violet, with a gleam of rose here and there, which means a house-roof half hidden, in the middle distance. Lady MacNairne admired the sketch particularly; and I got the idea—I hardly know why—that she was not quite pleased to have it given to me instead of to her.

(To be continued.)

Questions and Answers.

1st—Questions asked by bona-fide subscribers to "The Farmer's Advocate" are answered in this department free.

2nd—Questions should be clearly stated and plainly written, on one side of the paper only, and must be accompanied by the full name and address of the writer.

3rd—In veterinary questions, the symptoms especially must be fully and clearly stated, otherwise satisfactory replies cannot be given.

4th—When a reply by mail is required to urgent veterinary or legal enquiries, \$1.00 must be enclosed.

Miscellaneous.

Breeding Crate.

Could you tell me of any way to build a sling to take the weight of a cow when the bull is serving her, as the one I have is about 2,000 lbs., and is rather heavy for light cows? J. W.

Ans.—We have had descriptions of breeding crates for hogs, but have none on hand for a bull. We doubt whether it would work very well, and yet it might. If any of our readers have used such a device, will they kindly give us a description of it.

Tampering With Mail.

If a person by any means gets possession of an addressed and sealed letter, opens it, and relieves it of its contents, what more than an ordinary misdemeanor would such an offence be, and what might the penalty be? R. C. A.

Ans.—If this letter had been committed to the King's mails it would be a criminal offence for any one to procure it and open it other than the party to whom it is addressed. Such offences are provided for by the Criminal Code. See section 2 (i) and sections 364 and 365.

NOVEMBER

BeC

Twice
Half

You can see
The harder
No halter
You the ear
Giant Halt
next best.

Ask your de
money-saver
trouble get
mention th
will send y
see that y
you want
prices.

G. I. GRIFFIN
68 Water
Stratford

Do you
\$10 a
in you
Reliable pe
profitable.

AUTO-
Dept. 221
(Alco)

STORM,
WIND
and
BUG
PROOF

CHURCH
CHIMES
MEMORIAL BELL
FULLY WA
MCNEANE BELL
BALTIMORE, M
Chicago Office: Room 64
Establish

like vineyards of trailing brown
 es; and as we drew near to Sneek,
 ere we planned to stay the night, we
 an to meet quaint lighters, with
 ch picturesque family life going on
 board; children playing with queer,
 remade toys; ancient, white-capped
 nes knitting; girls flirting with young
 a on passing peat-boats—men in
 rlet jerseys white, coated in the
 oth water, looked like running fire
 er glass.

he old seventeenth-century water-gate
 Sneek was so beautiful, that we ex-
 ed—to like the place with the ugly
 e; but after all we hated it, and de-
 ed to spend another night in our
 floating houses.

l sorts of funny, water-noises waked
 early; but then, I hadn't slept very
 edly, because I couldn't help think-
 a good deal about Mr. van Buren,
 found a telegram waiting for him
 Sneek, and went away from us by
 first train he could catch. I don't
 w what was in the telegram, but he
 ed rather miserable as he read it.

I wondered a good deal in the
 t if his mother had called him back
 use Freule Menela van der Windt
 not pleased at having him stay so
 with us.

ll thought our next day's run, going
 ough the River Boorn to the Sneeker
 , past Grouw and on to Leeuwar-
 even more delightful than the day
 e; but it didn't seem as interesting
 e, somehow. Perhaps it was hav-
 a person who was partly Frisian
 ding by me all the time, and tell-
 me things, which made the dit-
 ce; anyway, I had a homesick feel-
 as if something were lacking. Mr.
 r said it would be nice to spend a
 ymnoon on board one of the nice lit-
 heries we saw in the big meer;
 I thought of Mr. van Buren and
 le Menela having theirs on one, and
 ve me quite a sinking of the heart.
 ed not to show that I was sad, but
 afraid Mr. Starr guessed, for in the
 noon he gave me a water-color
 h he had made in the morning, on
 He called it a "rough, impres-
 sive thing," but it is really ex-
 ce; the water pale lilac, with silver
 of foam, just as it looked in the
 when he sat painting; fields of
 of-gold, starred with wild flowers
 e foreground; far-off trees in soft
 and violet, with a gleam of rose
 and there, which means a house-
 half hidden, in the middle distance.
 MacNairne admired the sketch
 ularly; and I got the idea—I hard-
 low why—that she was not quite
 ed to have it given to me instead
 her.

Be Convinced before you pay a cent.



IF you only knew how quickly the 1900 Gravity Washer disposes of the week's wash, you would never again allow your clothes to be washed by hand. Clothes washed by a 1900 Gravity last longer. Saves your clothes—saves your hands—saves your health and time or the money you perhaps pay to have someone else do the work. Try it anyway, for 30 days. Not only send it free—I pay the freight—and I ask not a cent from you until you are convinced as I am that you need this machine. If you shouldn't agree with me, send it back. My book's free too. Write for it.

Address me personally,
**L. N. MORRIS, Manager,
 1900 WASHER COMPANY
 357 Yonge Street, Toronto**

**Twice the Strength
 Half the Cost.**



Examine Griffith's Giant at your dealer's. Look at the double stitching—the double leather or the russet belting—the 3/4 inch hard-tested rope.

**Griffith's
 Giant Halters**
 (\$1.25 West of Ft. William.)

You can see why a colt can't pull out of it. The harder the pull—the tighter it holds. No halter made—under two dollars—gives you the same strength. You can buy two Giant Halters for the price of one of the next best.

Ask your dealer to show you other Griffith's money-savers. If you have trouble getting Griffith's goods, mention this paper and we will send you the list, and see that you get what you want at regular prices.

**G. L. GRIFFITH & Son
 68 Waterloo St.
 Stratford Ont.**

Do you want to earn \$10 a week or more in your own home?

Reliable persons will be furnished with profitable, all-year-round employment on Auto-Knitting Machines, \$10 per week readily earned. We teach you at home, distance is no hindrance. Write for particulars, rates of pay, send 2c. stamp.



**AUTO-KNITTER HOSIERY CO.
 Dept. 221 257 College St. - Toronto
 (Also at Leicester, England)**

STORM, WIND and BUG PROOF

AGENTS Make \$25.00

A WEEK in their Spare Time Selling KNIGHTS' 400 CANDLE POWER LANTERN

One filling of gasoline costs about 3 cents and will keep it in operation for 15 hours. No wicks to trim, no chimneys to clean and no glassware to break. Just the thing for Poultrymen, Dairymen, Farmers and all outdoor purposes.

Write today for our offer if you want to make money in your spare time.

**KNIGHT LIGHT CO.
 519 Knight Building, Chicago**

CHURCH BELLS

CRIMES AND PEALS

MEMORIAL BELLS A SPECIALTY FULLY WARRANTED

McSHANE BELL FOUNDRY CO.,
 BALTIMORE, Md., U. S. A.
 Chicago Office: Room 64, 154 W. Randolph St.
 Established 1856

Questions and Answers. Miscellaneous.

Pump in the Barn.

1. We intend putting a pump in barn. Well to be driven. Would one two-inch pipe give greater satisfaction than two one-inch pipes driven side by side?

2. What size of force-pump would be required? Water to be forced 16 feet to the top of the tank. H. C.

Ans.—1. We would prefer the two-inch pipe.

2. It will depend upon the make of the pump, but the size of force-pump commonly used should be sufficient for the purpose. Procure one large enough if it is to be pumped by hand. One too small will be hard to operate.

Plank-Frame Barn.

I am a reader of your paper, "The Farmer's Advocate," and I am greatly taken up with it. I am about to build a barn, and as heavy timber is scarce out here, I would like to know whether I could obtain a plan of a plank-frame barn that would be strong enough when constructed to stand the high winds of this Western country? D. R. L.

Ans.—It is claimed that the plank-frame barn is as strong as any. We would advise you to enquire of builders in your district. We have a plank-frame barn at Weldwood, and it is giving satisfaction, but we do not get the severe winds you do on the prairies. If you decide to build this class of barn, give us the dimensions and we will give you a plan.

Salary for Trustee—Glauber's Salts.

1. Is it lawful in the Province of Ontario for a member of a School Board to accept a small salary for acting as Secretary-Treasurer of the Board, it being moved and seconded by two rate-payers (not members of the Trustee Board) at the annual meeting?

2. Is it safe to feed Glauber's salts to in-foal mares, and how much?

3. Have Glauber's salts any feeding value for fattening two-year-old steers, and how much? C. A.

Ans.—1. We think not.

2. It would not be wise to give salts. Salts are not the best purgative for a horse. Aloes are, but they are too strong for in-foal mares. Better use linseed oil.

3. The feeding value of Glauber's salts would be nil. Their action on the digestive systems of the steers might be such as to improve gains, provided a slight purgative were needed.

Re Soils Leaching—Alfalfa Root.

In looking over the list of bulletins supplied by the Government I fail to see one dealing with soils alone, that is, a work which describes the different types, and assists one in choosing between one soil and another.

1. Does sand soil leach more than clay?

2. How can leaching be prevented?

3. Is there a bulletin published that will give the desired information?

4. Does alfalfa extend its roots down for water alone? H. G. S.

Ans.—1 and 2. A sandy soil will undoubtedly leach more than a clay soil. It is more open, and will not retain moisture to the same extent as clay. Organic matter, such as may be supplied through barnyard manure or green manure, will render sandy or light soil more retentive of moisture and thus cause it to leach less than in its natural condition.

3. We do not have any recollection of a bulletin being published dealing with soils exclusively. Reference, of course, is made to different types of soils in most of the bulletins published, because no farm crop can be discussed intelligently without reference being made to the character and condition of the soil upon which it is to be grown. There are good books published on this subject, and they may be procured through this office.

4. In one sense of the word, every plant sends its roots down for moisture, because it is through this medium that the water-plant food is taken up. If the water-plant food is pretty deep in the soil, one can very well depend upon it that the alfalfa roots will go down until they reach it.

Sydney Basic Slag

WE want farmers of good financial standing to take the agency for this fertilizer in territory where we are not already represented. If you are the means of introducing SYDNEY BASIC SLAG into your district your neighbors will be grateful, and you will be reasonably remunerated for your trouble

Send us your name and address, and our general sales agent will call and go into particulars with you.

Write us immediately, as we are completing our selling arrangements for next spring in districts where we are not already represented.

The Cross Fertilizer Co., Limited Sydney, Nova Scotia

This Feed Cooker Will Pay for Itself

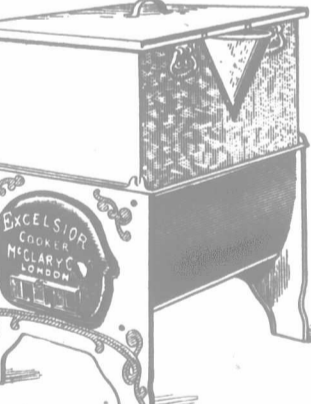

in the greater value it gives to feed.

Warm feed in winter is so beneficial to stock that the question now is chiefly, "What kind of a cooker is best?"

We will gladly send you a circular telling you all about

McCLARY'S EXCELSIOR COOKER

Burns any fuel. Lasts a lifetime.
 Made only by
McCLARY'S, London, Ont.

Clydesdale Stallions and Mares—We are now offering for sale a number of extra good stallions and mares in foal. They will be shown at the Guelph Winter Fair. Write or call on **JOHN A. BOAG & SON, Queenville, Ontario**

HIGH-CLASS CLYDESDALE MARES AND FILLIES
 We have a big selection of Imp. Clyde. Mares and Fillies and others from Imp. Sire and Dam. Buy now, for another year will see them away up in price. We have always a big selection of stallions.
SMITH & RICHARDSON, Columbus, Ont., Myrtle, Brooklyn and Oshawa Stations

ORCHARD GROVE HEREFORDS
 Have several young bulls and heifers for sale. Satisfaction guaranteed.
L. O. CLIFFORD :: :: :: Oshawa, Ont.

Willowbank Stock Farm Shorthorn Herd Established 1855. This large and old established herd has at the head the two great bulls: Imported Roan Chief =60865=, a Butterfly and the prize-winning bull, Browndale =80112=, a Mina. An extra good lot of young stock to offer of either sex. Splendid condition. **James Douglas, Caledonia, Ont.**
 Good families of both milking strain and beef.

Meadow Lawn Shorthorns We are offering a select lot of Scotch bulls and heifer, from 10 to 18 months old, from the Claret Wimples Marth, Roan Lady families. Sired by Proud Monarch No. 78792 by Blood Royal (imp). You are invited to inspect this offering. Bell telephone G.T.R. and C.R.R.
F. W. EWING, :: :: :: R.R. No. 1, Elora Ontario

Northlynd R. O. P. Shorthorns and Jerseys
 For Sale—Our noted sire of big milkers, St. Clair =84578= a Clara bred son of Waverly. Several of his sons out of R.O.P. dams; also Shorthorns and Jersey females. Official records is our specialty.
G. A. JACKSON, DOWNSVIEW P. O., ONTARIO, WESTON STATION.
 When writing advertisers, will you kindly mention "The Farmer's Advocate."

Questions and Answers.

Questions asked by bona-fide subscribers to the Farmer's Advocate are answered in department free.

Questions should be clearly stated and written, on one side of the paper only, and be accompanied by the full name and address of the writer.

In veterinary questions, the symptoms must be fully and clearly stated, otherwise satisfactory replies cannot be given.

When a reply by mail is required to veterinary or legal enquiries, \$1.00 must be enclosed.

Miscellaneous.

Breeding Cate.

Did you tell me of any way to build up to take the weight of a cow the bull is serving her, as the one is about 2,000 lbs., and is rather light cows? J. W.

—We have had descriptions of breeding crates for hogs, but have none for a bull. We doubt whether they would work very well, and yet it is a device, will they kindly give us a description of it.

Tampering With Mail.

Person by any means gets possession of an addressed and sealed letter, it, and relieves it of its contents, more than an ordinary misdemeanor such an offence be, and what might be the penalty? R. C. A.

—If this letter had been committed to the King's mails it would be a criminal offence for any one to procure or open it other than the party to whom it is addressed. Such offences are provided for by the Criminal Code. See sections 2 (1) and sections 364 and 365.

DANGEROUS
as well as painful

Backache Neuralgia
Lumbago Rheumatism
Stiff Joints Sprains
Gombault's Caustic Balsam
WILL RELIEVE YOU.

Its penetrating, soothing and healing and for all
Sores or Wounds, Felons, Exterior Cancers, Burns,
Blisters, Carbuncles and all swellings where an outward
application is required CAUSTIC BALSAM HAS NO
EQUAL. Removes the sores—strengthens the muscles.
Price \$1.50 per bottle. Sold by druggists or sent
by express prepaid. Write for Booklet L.
The LAWRENCE-WILLIAMS COMPANY, Toronto, Can.

Regular Agents Price \$13.50
For Only \$6.95



Odorless, Sanitary in-
door Closet. Closet
only \$6.95. Price of
outfit with closet, 1
gallon chemical, pipe
to flue, \$9.75. Cur-
tains or fixtures not
included—full direc-
tions with each.
Send no money—Pay
on examination.

THE HALLIDAY CO., LTD.
Factory Distributors, Hamilton, Canada

Dr. Page's English Spavin Cure

Cures the lameness from Bone-Spavins, Side-
Bones, Ringbones, Curbs, Splints, etc., and ab-
sorbs the bursas, does not kill
the hair, ab-
sorbs Capped
Hocks, Bog-
spavins thick past-
ern joints, cures lame-
ness in
tendons, most power-
ful absorb-
ent known, guaranteed, or money refunded.
Mailed to any address, price \$1.00. Canadian
Agents: J. A. JOHNSTON & CO., Druggists,
171 King St., East Toronto, Ont.

The Barrie Clydesdale Association
will sell without reserve, by PUBLIC AUCTION,
at the Market Square, Barrie, on Saturday,
Dec. 11th, at 2 p.m., the imported Clydesdale
stallion, Windfall [11237] (15527), black, foaled
1907. Windfall is a handsome horse, weighing
about 2,000 lbs., imported by Graham Bros., and
has proved himself a first-class stock horse, and is
only offered for sale because he has travelled for
five seasons in this district. Terms cash, or good
paper at three months. GEORGE RAIKES,
Secretary, Barrie P.O.

For Sale or Exchange

Three good imported stallions. A Clydesdale,
French Coach and Hackney. All are prize-winners.
Sound and right. Good workers and sure foot-
getters. Address:
Henry M. Douglas
:: Box 41 :: Ontario
20 Miles North of Barrie

Dr. Bell's Veterinary Medical Wonder, 10,000
\$1.00 bottles to horsemen who will
give the Wonder a fair trial. Guaranteed for
inflammation of the Lungs, Bowels, Kidneys
Fever, Distemper, etc. Send 10 cents for mailing
packing, etc. Agents wanted. Write address plainly.
Dr. Bell, V.S., Kingston, Ontario

For Sale—A Registered Clydesdale Filly,
two years old last July; a fine
specimen of this breed.

W. H. LITTLEFIELD, Brantford, Ont.

For Sale—Clydesdale Stallion, registered, sired by
Lord March, out of Pomona Matron, No. 33876.
Black, 4 white stockings and blaze. An exception-
ally well built and promising horse. Price reason-
able. Further particulars from
Pomona Farm, Cobourg, Ontario

For Sale A handsome team of grey carriage
horses, well mated, rising 7, quiet,
single or double; price \$500. For further particu-
lars apply—J. Riddell, care Conrad Schmidt,
R. R. No. 1, New Hamburg, Ont.

ALLOWAY LODGE STOCK FARM
Angus, Southdowns, Collies

Special this month:
Southdown Prize Rams
ROBT. McEWEN, R.R. 4, London, Ont.

Aberdeen Angus For sale—males
and females any
age.
Walter Hall, R. R. No. 4,
Bright, Ont.

Questions and Answers.
Miscellaneous.

Fertilizer.

Did you ever have any experience with
basic slag, or do you know of any other
good fertilizer? My soil is a light
sandy loam. W. M. D.

Ans.—A great deal depends upon the
class of crop you intend to grow. Basic
slag gives good results on roots and
meadows, and sometimes on grain. It
depends on the needs of the soil. A
complete fertilizer consisting of super-
phosphate, nitrate of soda and muriate
of potash, is good, but potash is diffi-
cult to obtain since the war. There are
several firms manufacturing prepared
fertilizers and who advertise in these
columns from time to time, and we
would advise that you get in touch with
them. First know what your soil re-
quires. This must largely be determined
by experimentation. Also study the re-
quirements of the crop to be put on it.

Horses have Eczema.

I have a team of horses which are
very itchy. I have tried different treat-
ments, and went to see a man who pre-
tends to know something about horses.
He said they had the itch and gave me
some medicine for them, but it did them
no good. I have fed them salts and
sulphur, and have also bled them, but it
did not effect a cure. They seem very
itchy indeed. When they get out they
rub every place they can get a chance
at. Otherwise they feel well, and are
in good working order. J. C. T.

Ans.—First, examine these horses for
lice, and if they are lousy use some pre-
pared lice powder, or work a mixture of
one part hellebore and four parts cement
well into the hair. From the descrip-
tion we would consider that they had an
attack of eczema. For this, administer
a purgative of 8 drams of aloes and 2
drams of ginger. Follow up with 1½
ounces Fowler's Solution of Arsenic,
twice daily for a week. Give them a
thorough washing with strong, warm,
soft-soap suds, well applied with a scrub-
bing brush. Then dress thoroughly
every second day until cured with a
warm five-per-cent. solution of Creolin in
water. It is much easier to treat for
this disease when the animal is clipped.
It will do no good to bleed.

Lad Leaves—Horse Coughs—Eczema.

1. I had an English lad working for
me who left my employ in August, 1914.
He left his box when he went away, say-
ing he would advise me of his where-
abouts in a short time, but up to the
present time I have not heard
from him, nor do I know where to
find any of his relatives or friends. The
box is locked just as it was when he
left here. What can I do about it, as
I do not want to keep it indefinitely?

2. I have a nine-year-old gelding that
has had a cough for some time, not a
hard cough, but coughs at intervals. I
keep giving him a little pine tar, but it
does not seem to stop it. He coughs
most when in the stable. What can I
do for him?

3. I have a mare that keeps biting
and rubbing herself when in the stable.
She bites as far back on her body as
she can reach. I do not see any signs
of lice; her coat is heavy. I have been
feeding a little stock food in the grain,
working her right along, and she is in
good condition and spirits. What can I
do for her?

4. What is a good disinfectant to mix
with whitewash for henhouse and cow
stable? W. G.

Ans.—1. We do not see that you should
worry about it. Simply leave the box
as he left it, and probably he will turn
up and claim it later. Or if you wished
you might place an advertisement in some
of the leading daily papers asking his
whereabouts.

2. Give him every morning 1 dram of
powdered opium, 1½ drams solid extract
of belladonna, 1 dram camphor, and 30
grains digitalis, mixed with sufficient oil
of tar to make plastic. Roll in tissue
paper and administer, or mix with ½ pint
of cold water and give as a drench.

3. See answer to J. C. T. in this
issue.

4. Five-per-cent. carbolic acid, or
Zenoleum according to directions.

Dispersion Sale of
45 Head Holstein Cattle

ON
Wednesday, Dec. 8, 1915
At Burnbrae Head Farm, Melrose, Ont., ten miles west
of London on Sarnia Gravel Road.

This offering comprises one registered bull, 21 grade cows
from two to seven years old, one cow fresh Oct. 15th, two farrow
cows milking well, will make good winter milkers, two 2-year-
old heifers bred, seven yearling heifers served, eleven heifer
calves sired by Homestead King Colantha Abbekerk No. 10467
and from choice cows. This is one of the best dairy herds in
Western Ontario. Parties wanting dairy cattle should attend
this sale. Every animal offered will positively be sold as cir-
cumstances prevent the proprietors from continuing dairying for
the present.

TERMS: 10 months on bankable notes, 6% per annum off for cash.
Sale commences at 1 o'clock. Accommodation provided for those from
a distance. All trains will be met on day of sale at Komoka, G.T.R. & C.P.R.
Auctioneers: LINDSAY & POUND, Aylmer, Ont.
JOHN McPHERSON, Clerk. **SCOTT BROS., Proprietors**
Hyde Park, Ont.

Entries positively close November 25th for the
SIXTH ANNUAL

Toronto Fat Stock Show

Union Stock Yards, TORONTO

MAIL ENTRIES NOW TO:

C. F. TOPPING, Secretary
Union Stock Yards, Toronto

For all regular classes and T. Eaton & Co. Special, Walker
House Cup, Queen's Hotel Cup, Gunns' Limited Specials,
Harris Abattoir Specials, Armour & Co. Special, Mathews-
Blackwell special, Wm. Davies Co. Specials, Swift Canadian
Specials, Toronto World Special.

BULLS ON HAND TO OFFER FROM \$125.00 UP



Field Marshall = 100215 =, first senior
bull at Toronto and London, 1915.

- Sylvan Power = 95871 =, white, calved Feb. 9, '14
Dam Nonpareil Courtier = 83324 =
Lily Fragrance (imp.) Old Lancaster (imp.)
Collynie Fragrance (imp.) Scottish Fancy (76601)
- This bull won first at Western Fair this year.
- Eramosa Ringleader = 101651 =, red, Sept. 3, '14
Broadhooks Ringleader = 83494 =
Sweet Fragrance (imp.) Alastair = 78217 =
3. Gilt Edge = 101652 =, red, little white, Dec. 7, '14
Bandsman's Commander = 90929 =
- Lily Fragrance (imp.) Old Lancaster (imp.)
Collynie Fragrance (imp.) Scottish Fancy (imp.)
4. Spring Tide = 101653 =, red, little white, May 2, '15
Bandsman's Commander = 90929 =
- P. V. Victoria Ben Lomond (imp.)
Victoria Lady Grengill Victor (imp.)
Princess Victoria (imp.) Morning's Pride
5. Conqueror's Crown, dark roan, June 11, '15
Bandsman's Commander = 90929 =
Victoria 75 Broadhooks Ringleader = 83494 =
Victoria of P. V. Lancaster Floral
Princess Victoria (imp.) Morning's Pride
and others

A. F. & G. AULD, R. R. No. 2, GUELPH, ONT.

20 IMPORTED BULLS

These imported bulls, along with 10 home bred bulls may now be seen at our farms. There are some
choice ones among them. We also imported four cows and a heifer, all of which are forward in
calf. An invitation is extended to anyone interested in this class of stock to visit us at any time.
Correspondence will receive our most careful attention.

Burlington Jct. G. T. R. :: :: J. A. & H. M. PETTIT,
Burlington phone or telegraph. Freeman, Ont.

Shorthorns

Pure Scotch and Scotch topped—Booth. Also five (5)
young bulls from ten to twenty months old, of the
low down, thick kind, good colors—reds and roans.
Prices reasonable. G. E. Morden & Son, Oakville, Ontario

IRVINEDALE SHORTHORNS

Bulls and heifers of the very best quality. Sired by Gainford Select
(One of the great sons of the celebrated Gainford Marquis).
JOHN WATT & SON, R. R. No. 3, Elora, Ont.

Maple Grange Shorthorns

Pure Scotch and Scotch-topped
Breeding unsur-
passed. A nice selection in young bulls, and a limited number of thick, mossy heifers.
R. J. DOYLE, Owen Sound, Ontario

PLEASE
CRU
R.M
WES
FORTNIG
By Twin-S
SPECIAL FACI
Next Sailing
R.M.S.P. "C
APPLY TO
The Royal Ma
67-55, Granvill
Local T

Windsor
Hig
W
A s
of c
point
Win
for
nest
tool
file

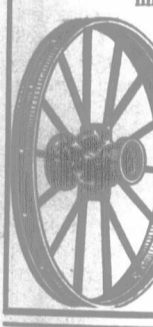

CANADIA
Fast "Da
TO WIN
VAN

Via THE T
Leaving Toronto
Train leaves 1.20 p
No Change. See T
CANADIA
Particulars from
C.P.R., London, Ag

Oakland—
For Sale—Our stock b
of the finest age, 8 to
others from 6 months to
breeding females of the
Jno. Elder & Son

SHOR
Three bulls, 11 months
with their calves, c
heifers for sale. G
Pedigrees. IR
J. T. GIBSON,

SHORTHORN BUL
eight bulls and t
twenty months, for sa
and prices moderate. B
you buy. Oshawa B
Woodbine Stock Farm

Choice stock to offer in S
CHINA AND CHEST
Poland China herd at 1
Pairs not akin—bred fr
erate. Geo. G. Gould

Shorthorns a
also cows and heifers o
calves at foot. Also ch
ANDREW GROFF, R

BURNFOOT STOCK
Breeder of Heavy Milk
Present Offering a choic
1915, a grandson of D
cow in the R.O.P. for S
MOORE, Prop., Caled

FLETCHER'S
Our herd of pure Scot
direct from (imp.) stock
for sale, also females.
R. R. 1, Erin, Ont. L.

Sale of Prize Cattle

8, 1915
Ont., ten miles west
Travel Road.

red bull, 21 grade cows
sh Oct. 15th, two farrow
er milkers, two 2-year-
s, served, eleven heifer
ha Abbekerk No. 10467
the best dairy herds in
ry cattle should attend
ositively be sold as cir-
continuing dairying for

% per annum off for cash.
ion provided for those from
at Komoka, G.T.R. & C.P.R.
BROS., Proprietors
Hyde Park, Ont.

ber 25th for the

Stock Show

ORONTO

ecretary

oronto

& Co. Special, Walker
ans' Limited Specials,
Co. Special, Mathews-
cials, Swift Canadian

FROM \$125.00 UP

=95871 =, white, calved Feb. 9, '14

Sire

Nonpareil Courrier = 83324 =

(imp.) Old Lancaster (imp.)

Scottish Fancy (75601)

at Western Fair this year.

leader = 101651 =, red, Sept. 3, '14

Broadhooks Ringleader = 83494 =

(imp.) Alastair = 78217 =

1652 =, red, little white, Dec. 7, '14

Bandsman's Commander = 90929 =

Old Lancaster (imp.)

(imp.) Scottish Fancy

101653 =, red, little white, May 2, '15

Bandsman's Commander = 90929 =

Ben Lomond (imp.)

Greenhill Victor (imp.)

(imp.) Morning's Pride

rown, dark roan, June 11, '15

Bandsman's Commander

Broadhooks Ringleader = 83494 =

Lancaster Floral

(imp.) Morning's Pride

and others

D., R. R. No. 2. GUELPH, ONT.

BULLS

seen at our farms. There are some

heifer, all of which are forward in

class of stock to visit us at any time.

J. A. & H. M. PETTIT.

Freeman, Ont.

atch topped—Booth. Also five (5)

en to twenty months old, of the

PLEASURE CRUISES BY R.M.S.P. TO WEST INDIES

FORTNIGHTLY SAILINGS
By Twin-Screw Mail Steamers.

SPECIAL FACILITIES FOR TOURISTS.

Next Sailing from HALIFAX:
R.M.S.P. "Chaudiere," Dec. 3, 1915

APPLY TO
The Royal Mail Steam Packet Co.,
67-69, Granville Street, HALIFAX (N.S.)
OR TO THE
Local TICKET AGENCIES.

Windsor Circular Saws

High grade. Low prices. All
sizes. Fully warranted.



Windsor Stock Feed Cookers
A safe, simple and cheap means
of cooking feed. Many superior
points of merit. Price \$9 up.

Windsor Combination Outfit
for repairing boots, shoes, har-
ness and tinware. Practical
tools, no toys. A useful and
profitable outfit for only \$2.75.

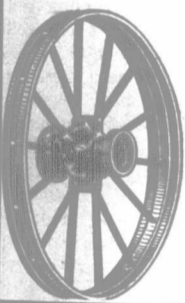

Windsor Tank Heaters
filled with either wood or coal
morning and evening
will keep a 40-bbl. tank
from freezing in zero
weather. Price \$4.75.

Windsor Steel Wheels
for farm wagons. High-
est quality. Low prices.
A full list of self-
educational books.

Write for our
Catalogue

Windsor Supply Co.
Windsor, Ont.

CANADIAN PACIFIC Fast "Daily" Service

TO WINNIPEG AND
VANCOUVER

Via THE TRANS-CANADA

Leaving Toronto 6.40 p.m. Connecting
Train leaves 1.20 p.m. Through Trains—
No Change. See that your ticket reads

CANADIAN PACIFIC

Particulars from H. J. McCALLUM, C.P.A.,
C.P.R., London, Agent, or write

M. G. MURPHY,
Dist. Passgr. Agt., Toronto

Oakland—65 Shorthorns

For Sale—Our stock bull Scotch Grey 72692; one
of the finest aged Roan bulls in Ontario, also 11
others from 6 months to 2 years old and a dozen
breeding females of the profitable kind at \$100 each.

Jno. Elder & Sons, Hensall, Ontario

SHORTHORNS

Three bulls, 11 months, a number of younger cows
with their calves, cows in calf and yearling
heifers for sale. Good individuals. Good
pedigrees. Inspection solicited.

J. T. GIBSON, DENFIELD, ONT.

SHORTHORN BULLS AND HEIFERS

Eight bulls and ten heifers, from eight to
twenty months, for sale. The best of breeding
and prices moderate. Write me your wants before
you buy. Oshawa Bell phone. G. E. BAIN,
Woodbine Stock Farm, Taunton, Ont.

Choice stock to offer in SHORTHORNS, POLAND
CHINA AND CHESTER WHITES. First prize
Poland China herd at Toronto and London, 1915.

Pairs not akin—bred from winners. Prices mod-
erate. Geo. G. Gould, No. 4, Essex, Ont.

Shorthorns and Swine

Have some choice young bulls for sale;
also cows and heifers of show material, some with
calves at foot. Also choice Yorkshire sows.
ANDREW GROFF, R.R. No. 1, ELORA, ONT.

BURNFOOT STOCK FARM, Caledonia, Ont.

Breeders of Heavy Milking dual purpose Shorthorns.
Present Offering a choice roan bull, born April 9th,
1915, a grandson of Dairymaid, 89088, the leading
cow in the R.O.P. for Shorthorns in Canada. S.A.
MOORE, Prop., Caledonia, Ont.

FLETCHER'S SHORTHORNS

Our herd of pure Scotch shorthorns are mostly
direct from (imp.) stock. Three very choice bulls
for sale, also females. - Geo. D. Fletcher,
R. R. 1, Erin, Ont. L. D. Phone. Erin Sta. C.P.R.

Questions and Answers. Veterinary.

Cow Pox

1. Cow's teats swell here and there,
break out and discharge a little and
form scabs. I treat with carbolic acid
and oil, but while it helps, it does not
effect a cure.

2. What internal treatment is needed?
3. How long should it take to treat
the herd so as to prevent the possibility
of a recurrence?

R. K. C.

Ans.—1. This is cow pox. It is very
contagious, hence all affected should be
isolated, and great care taken not to
carry the infection to healthy cows on
the hands of milker, clothing, stable
utensils, etc. Get an ointment made of
4 drams boracic acid, 20 drops carbolic
acid, and 2 ounces vaseline. Dress the
parts with this three times daily until
cured. If necessary, use a teat syphon
to draw the milk.

2. None.
3. It is not possible to render the
herd immune if subjected to infection.
A cure is usually effected (provided fresh
infection does not occur) in from two to
three weeks, but in some cases it may
require a longer period. V.

Sequels to Shipping

1. Mare that had a cold was shipped
from the Pacific coast to Central Sas-
katchewan. The night she was unladen
it was cold and raining and she got
wet. She became weak, and coughed
and discharged from nostrils. She is
still weak, and has not proper control
of her limbs. If backed quickly she falls
down. She still coughs.

2. Another horse that was shipped at
the same time was put to work and in
a short time lost his appetite, began to
cough, and died. A post-mortem re-
vealed the liver dark and solid, and the
kidneys covered by a yellowish mem-
brane. W. T. S.

Ans.—This mare was not in fit con-
dition to ship. The journey, followed by
exposure to cold rain, aggravated the
pulmonary trouble and caused partial
paralysis, from which it is doubtful if
she will recover. Give her every morn-
ing 1½ drams of powdered opium, 2
drams solid extract of belladonna, 80
grains digitalis, and 1 dram camphor,
with sufficient oil of tar to make plastic.
Roll in tissue paper and administer as a
ball, or mix with warm water and ad-
minister as a drench.

2. The change of climate, food, water,
and general environment, and the fact
that he was put to work at once, had
such an effect upon his constitution that
he succumbed. If he had been rested for
a while and then gradually accustomed
to work, the results would probably have
been different. V.

Miscellaneous.

Foreclosure of Mortgage.

A sells farm to B for a cash deposit,
and balance on mortgage for a term of
years, and there is an agreement to pay
interest and a yearly payment of prin-
cipal remaining on mortgage. If B pays
interest, but fails to pay the stated
amount of principal, can A foreclose
mortgage before expiry of term of years
of mortgage, and if so, must he sell, or
can he take the farm again as it stands?
Ontario. X. Y. Z.

Ans.—On default in respect of either
principal or interest, A can bring an
action of foreclosure, and the Court in
such action, on application of B, may
order a sale of the land in lieu of a
foreclosure. Or, on such default as men-
tioned, A may exercise the power of sale
contained in the mortgage, but only after
waiting for the expiration of the period
of default stipulated in the power of sale
clause, and also until after giving the
notice provided for by the clause and
expiry of the period of such notice.

If the mortgage was made prior to 4th
August, 1914, no foreclosure or sale pro-
ceedings can lawfully be taken for default
in respect of payment of principal, or
any instalment thereof, unless by leave
of a judge

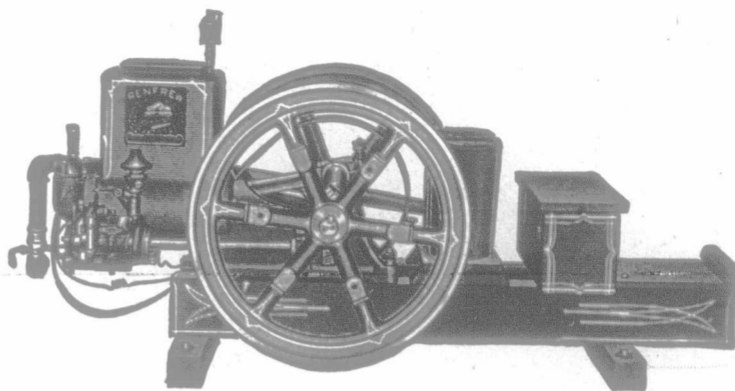

A High Tension Magneto as Well as Batteries

In addition to the regular equipment of batteries the Renfrew Standard
gasoline engine is now equipped with a high tension magneto. This means
that the Renfrew Standard now has two complete ignition systems, each one
entirely independent of the other. With this dual ignition equipment the

Renfrew Standard It starts without cranking

is a doubly reliable engine—one that comes as near to giving an absolutely
perfect service day in and day out as it is possible for an engine to do.

Do not confuse this high tension magneto equipment with the low tension
magneto or dynamo you can procure with some engines. With the low ten-
sion magneto, unlike the high tension, you cannot start the engine without
batteries; but with the high tension magneto you can both start and run the
Renfrew Standard without the aid of batteries should the latter become weak
or exhausted.

With the Renfrew Standard gasoline engine you now get dual ignition,
fly ball governor, bearings running in best babbitt, most economical carburetor
built, semi-steel cylinders, and an engine that is considerably larger in size
than ordinary engines of same rating. More high-grade features, more
metal, more strength, more service, more value for your money—that is
what you get with the Renfrew Standard. We include a lever type friction
clutch pulley without charge on engines of 6 h.-p. and up.

Grain grinders, saw frames and B. Bell & Son ensilage cutters furnished
at very reasonable prices.

Engine catalog, describing sizes from 1½ h.-p. to 60 h.-p. free on request.

The Renfrew Machinery Co. Ltd.

Head office and Works, Renfrew, Ont.

Agencies almost Everywhere in Canada.

GLENGOW SHORTHORNS

For this season's trade we have the best lot of young bulls we ever bred. Wedding
Gifts, Strathallans, Crimson Flowers and Kiblean Beautys, sired by Broadhooks Prime.
These are a thick, mellow, well bred lot. Heifers from calves up.

WM. SMITH & SON, COLUMBUS, ONTARIO

Rosedale Stock Farm offers for quick sale at low prices one 2-year-old Shire
stallion, champion at Toronto. One 2-year-old and one
yearling Hackney stallions, both imp. and both first at Toronto. One Hackney pony horse foal, dam
champion at Toronto. Two Clyde horse foals, sire and dam imp. Ten Shorthorn bulls. A few
choice Leicester ram lambs.

J. M. GARDHOUSE, Weston, Ont., G.T.R., C.P.R. and Electric Line.

Blairgowrie Shorthorns

Special offering for 30 days at reduced prices to make room
for stabling. Bulls of serviceable age, young cows with
calves by side and heifers in calf. Choice shearing and ram lambs,
also ewes—both Cotswold and Shropshire.

JOHN MILLER, Ashburn, Ont. Myrtle Sta. C.P.R. & G.T.R.

Shorthorns

RICH IN BREEDING, HIGH IN QUALITY.
My herd of Scotch and Scotch-topped Shorthorns
was never stronger in number nor in quality than
now. I have the most fashionable blood of the
breed in pure Scotch, as well as the greatest milking blood strains. Visit the herd. Also some right
choice Yorkshires, both sexes. A. J. Howden, Myrtle, C.P.R.; Brooklin, G.T.R.; Columbus, R.M.D.

SHORTHORNS AND CLYDESDALES

10 Bulls serviceable age, all good ones (some herd-headers) and are offering females of all ages. Have
a choice lot of heifers bred to Clansman = 87809 =; also four choice fillies all from imported stock.
A. B. & T. W. DOUGLAS Long-Distance Phone :: STRATHROY, ONTARIO

Shorthorn Cattle and Lincoln Sheep

Established 50 years our herd was never so strong as now of strictly high-class quality and breeding
we have young cows in calf, heifers all ages, high-class young bulls, show animals a specialty.
Lincoln sheep, ram and ewe lambs of highest quality.

JOHN GARDHOUSE & SONS :: WESTON, ONTARIO

SHORTHORNS OF SHOW-RING QUALITY

We have this year
the best lot of young
bulls we ever bred
from the famous sire, Mildreds Royal, Sr. Calves, Matchless and Emmelines, they are all of show-
ring calibre.

GEO. GIER & SON, R.M.D. WALDEMAR, ONT., P.O. AND STATION

PLEASANT VALLEY FARM SHORTHORNS

Your opportunity to buy a good shorthorn bull as a herd header or to raise better steers is right now.
We have 10 good ones for either purpose by imp. Loyal Scot, also several cows and heifers. Write us
before buying. GEO. AMOS & SONS, Moffat Station, C.P.R. (11 miles east of Guelph.)

Spring Valley Shorthorns

—Herd headed by the two great
breeding bulls, Newton Ringleader
(imp.) 73783, and Nonpareil
Ramsden 83422. Can supply a few of either sex:

KYLE BROS., Drumbo, Ont. Phone and telegraph via Ayr.

Shorthorns and Shropshires

Am offering six young bulls at reasonable
prices ranging in age from 7 months to
19 months. A good lot. Also 10 Shropshire
shearing ewes; a first-class start for a flock
low set and well covered.

Wm. D. Dyer, R.R. No. 3, Oshawa
Brooklyn G.T.R. Myrtle C.P.R.

City Conveniences for Country Homes---Write!



Why not have a first-class bathroom like this in your home, with plenty of running hot and cold water, and a handy kitchen sink with the same conveniences—all fitted up complete.

Every member of the family will welcome the change and benefit by the improved conditions.

Prices complete, \$225 and upwards

The unsanitary cesspool outdoors is a constant danger to health and means exposure to cold and disease. Why go on putting up with miserable conditions that belong to the Middle Ages? Let us send you particulars. There is an

EMPIRE WATER SUPPLY SYSTEM

that will meet your every requirement. The cost is moderate—the work will be first-class—the time, health and labor saved will repay the cost in short order—the improvement will be permanent.

Our outfits won Diploma at the Western Fair this year. We have installed many in all parts of the country. Write us to-day for complete catalogue. Estimates free.

EMPIRE MFG. CO., LIMITED
East London, Ont.

An Answer to "A. L." on School Fairs.

Editor "The Farmer's Advocate":

I will take the negative side of the argument which appeared in your very valuable farm paper in the issue of November 4. Probably this was not meant for debate, but when I read that account of the man in the eastern county regarding the dark side of School Fairs, I was forced to take up my pen in defence of them.

Near the end, this worthy writer drew our attention to the fact that he is a great agriculturist, and an upholder of any movement that will tend to advance agricultural welfare. What I want to ask is this: Why did that man spend so much valuable time in criticising, when he might have been doing something to straighten matters out in that fifty-year-behind-the-times county of his? His letter would be poor encouragement for a county or section that has never joined the School Fair movement and was dubious about joining. They would say, we will stay out, and in that way this great agriculturist, who upholds everything that tends toward the advancement of better farming, would probably be the cause of having no School Fair. It is the best move yet to keep the boys on the farm.

Let me prove my arguments. In the first place, he spoke of grandmother's fried cakes, ma's bread, pa's colt, brother's apples, and sister's bugs and weed seeds. He doesn't say these are facts if you will notice, but, supposing they are, this is only one section he has reference to. I will state a fact I know to be true, because the teacher went and watched one girl make her cake and bread, and she did it under her mother's instructions, but her mother did not touch the dough. This girl won a prize. That same little girl will not forget in a day how that bread was made, because she won a prize, and is proud of it, and I will wager she has tried her hand again since. One boy won a prize on his collection of weed seeds, and I know that he gathered them himself. No doubt he got help to name them, but would my worthy agriculturist expect that boy to know them all, and him only twelve years old. However, that is not the question. He knows them now, and will not soon forget them. I have had this boy show them to me and name them over. About pa's colt, what if it was pa's colt, and if it was over age it was the Fair Directors' fault if this was the case, but will that boy, supposing the colt won a prize, take a greater interest in it after the Fair than if it had never been shown? If it had not been for the Fair the boy probably would not have known such a colt was on the farm. He will at least know that much. About the apples that big brother gathered, I know a boy that at twelve years old correctly named nearly every variety of apples at an Exhibition, not a School Fair. Big brother would not have been much use in that case.

I have touched on some of the things that the elders could help the children with. I will mention something they could not help them with (I notice my worthy upholder of agriculture did not mention them, and I hope to gain a point), namely, public speaking and stock judging. It makes no difference how a father, mother, brother or sister may rush around and do their best, they can't make a child a public speaker without some effort on his or her own part. We live in an age when we need men and women who can get up and express their opinions of the everyday occurrences that take place, and the need is becoming daily more imperative. The person who cannot get up and say something when he is called upon to do so has to take a back seat with the rising generation. I may say that in our county there were some fine speeches made at the School Fairs this fall, speeches that would be a credit to orators much older than the young contestants who competed. This is something that will not leave them, even if they do eat their seed potatoes the next

The "every purpose" Ammunition

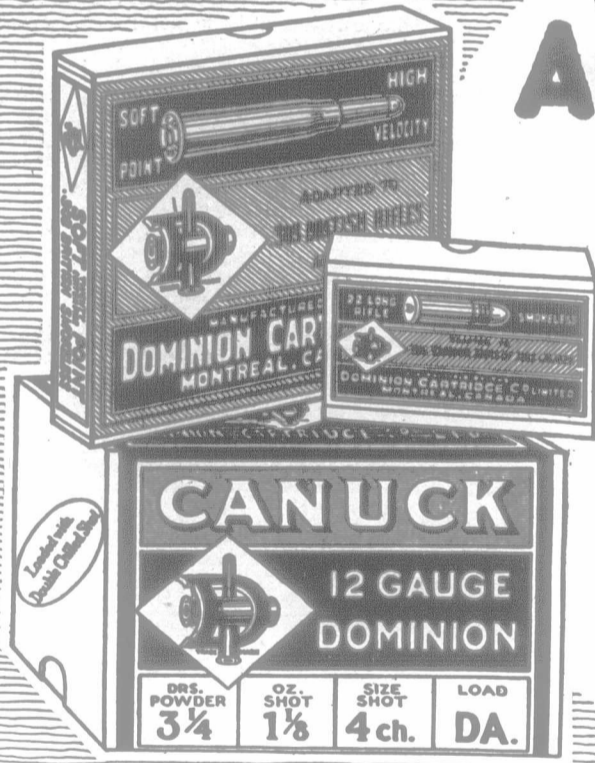

For every popular gun—every kind of game—every shooting purpose—there's a Dominion load of a size and power that's exactly right. Five kinds of shot shells in all standard gauges.

More than a hundred different metallics—from BB Caps to high power sporting cartridges. All powders used are standard—black and smokeless—(also Lesmok in 22's).

Materials and manufacturing methods are 100% perfect. The system of inspection and testing is rigid and accurate. Guaranteed dependability is the result. Send 10 cents for 16 game pictures.

"The Ammunition Made wholly in Canada." Sold everywhere.
DOMINION CARTRIDGE CO., LIMITED,
858 Transportation Bldg., Montreal.

Shoot Dominion Shot Shells & Metallics

Cotton Seed Meal

LINSEED AND FLAX MEAL AND SEED

H. Fraleigh, Box 1, Forest, Ont.

Shorthorns high class young bulls from 7 to 18 months, 15 young cows and heifers, straight, smooth big kinds of choicest breeding including several families that have produced dairy test winners. I never was in a better position to supply you with a good young bull at a more reasonable price. Write me or come and see them.

Stewart M. Graham
Long distance Phone, Lindsay, Ont.

Plaster Hill Shorthorns

Six young bulls 8 to 14 months. Eight females, those of breeding age in calf. Some qualified in R. O. P. and others from R. O. P. cows. Among these some choice show animals. Prices right. Terms to suit purchaser.

F. Martindale & Son, Caledonia, Ont.
Long-Distance Phone Station and P.O.

SHORTHORNS, bulls, females, reds, roans, size quality, breeding milkers over 40 years, cows milking 50 lbs. a day. The English, Rothchild's bull Mortimore in herd, the kind you want. Prices easy. Thomas Graham, R.R. 3, Port Perry, Ont. Please mention "The Farmer's Advocate."

Escana Farm Shorthorns

For Sale—15 bulls 8 to 14 months old, several of them prize-winners at Toronto and London, sired by the noted imported bulls Right Sort and Raphael. Also for sale—20 heifers and cows of choice breeding and quality for show or foundation purposes. State your wants and we will send copy of pedigree and prices. Mail orders a specialty, satisfaction guaranteed.

MITCHELL BROS. Burlington P.O., Ontario
Jos. McCrudden, Manager. Farm ¼ mile from Burlington Jct.

A Reasonable Chance to Buy a Well-bred, Good, Young SHORTHORN BULL

at a small price; I have three January calves which I want to move at once. Also four or five a little older.

Will A. Dryden, Maple Shade Farm, Brooklin, Ont.
Brooklin, G. T. R., C. N. R. Myrtle, C. P. R.

Robert Miller pays the freight, and in addition he is offering a roan 2-year-old bull that has not been beaten, bred direct from imported stock and a grand sire. A yearling bull, first the only time shown, direct from imported stock, also proven sure and right, and several younger bulls of the very highest class, in beautiful condition, at great value for the money asked. Females of all ages, some of them prize-winners, some of them great milkers and bred that way, some of them of the most select Scotch families that will start a man right. If you let me know your object, I can price you a bull to suit your purpose, at a price that you can pay. Shropshire and Cotswold rams and ewes for sale as usual. Our business has been established for 79 years, and still it grows, there is a reason. **ROBERT MILLER, Stouffville P.O. and Station, Ontario.**

The Salem Shorthorns

One of the largest collections of Scotch Shorthorns in America. Can suit you in either sex, at prices you can afford to pay.

J. A. WATT :: :: ELORA, ONT.
H. SMITH :: :: HAY P.O., ONT.
21 SHORTHORN BULLS and as many heifers for sale. Write your wants. You know the Harry Smith Standard.

HINMAN
THE UNIV...
Made...
Why have you not e...
HINMAN
Write for booklet...
with the F...
Price, \$50...
H. F. BA...
Sole Manufac...
Galt,

Ring
Boi
There is no case so...
had that we will not...
Flem...
Spavin and l...
to remove the lamene...
sion. Money refund...
to use and one to thr...
cure. Works just as w...
Spavin. Before order...
of a remedy for any...
for a free copy of...
Fleming's...
Veterina...
Thirty-six pages of...
with special attention...
taken. Durably bound...
shows a right beginn...
book.
FLEMING B.
79 Church St.

Farmers' Cemen
Walkers

The London En
LIM...
will have their r...
vertisement in...
advertisement...
1818 of N

Walnut Gro
Herd headed by May Be...
of May Echo Slys...
seven days. Females...
upwards. Prices right...
C. R. JAMES Lan...
Phone 7

Holsteins C
Yorks...
A sample of Minister Far...
whose Jr. 2 year old dam...
year old dam average 14...
heifers from R. O. P. co...
etc. For full particulars...
RICHARD HO
R. R. No. 1, DART

RIDGE DALE HOLSTE
calf ready for service, a...
them sired by King Scis...
young cows. Prices low...
Walker & Sons, R. R...
Manchester, G.T.R., My

For Sale Registered...
half white...
Mercens' grand champ...
into 1913.
H. KEM

Pedigreed H
for sale, 15 mon...
BEROLD'S FARMS

Answer to "A. L." on School Fairs.

The Farmer's Advocate:
 I take the negative side of the which appeared in your very farm paper in the issue of 4. Probably this was not a debate, but when I read that of the man in the eastern regarding the dark side of School fairs as forced to take up my pen of them.

end, this worthy writer drew on to the fact that he is a culturist, and an upholder of ent that will tend to advance welfare. What I want to : Why did that man spend valuable time in criticising, might have been doing some- straighten matters out in that hind-the-times county of his? would be poor encouragement ty or section that has never School Fair movement and s about joining. They would l stay out, and in that way agriculturist, who upholds that tends toward the ad- of better farming, would prob- cause of having no School s the best move yet to keep the farm.

rove my arguments. In the he spoke of grandmother's ma's bread, pa's colt, ples, and sister's bugs and He doesn't say these are will notice, but, supposing is only one section he has I will state a fact I know because the teacher went and the girl make her cake and he did it under her mother's but her mother did not ough. This girl won a prize. little girl will not forget in that bread was made, be- on a prize, and is proud of ill wager she has tried her since. One boy won a prize ction of weed seeds, and l e gathered them himself. No t help to name them, but worthy agriculturist expect o know them all, and him years old. However, that question. He knows them l not soon forget them. I s boy show them to me and ver. About pa's colt, what 's colt, and if it was over the Fair Directors' fault if e case, but will that boy, e colt won a prize, take a est in it after the Fair than ven been shown? If it had the Fair the boy probably ave known such a colt was He will at least know About the apples that big red, I know a boy that at old correctly named nearly of apples at an Exhibition. Fair. Big brother would a much use in that case.

ched on some of the things rs could help the children l mention something they p them with (I notice my der of agriculture did not and I hope to gain a y, public speaking and stock makes no difference how a r, brother or sister may and do their best, they child a public speaker with- rt on his or her own part. n age when we need men ho can get up and express of the everyday occur- ke place, and the need is y more imperative. The not get up and say some- is called upon to do ake a back seat with the on. I may say that in ere were some fine speeches School Fairs this fall, would be a credit to older than the young con- competed. This is some- ll not leave them, even if heir seed potatoes the next

HINMAN THE UNIVERSAL MILKER

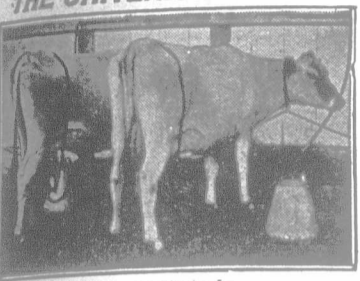

Made in Canada

Why have you not equipped your stable with a **HINMAN MILKER?**

Write for booklet H, "Making More Money with the Hinman Milker"

Price, \$50.00 per Unit

H. F. BAILEY & SON
 Sole Manufacturers for Canada
 Galt, Ont., Can.

Ring-Bone



There is no case so old or bad that we will not guarantee

Fleming's Spavin and Ringbone Paste

to remove the lameness and make the horse go sound. Money refunded if it ever fails. Easy to use and one to three 5-minute applications cure. Works just as well on Sidebone and Bone Spavin. Before ordering or buying any kind of a remedy for any kind of a blemish, write for a free copy of

Fleming's Vest Pocket Veterinary Adviser

Ninety-six pages of veterinary information, with special attention to the treatment of blemishes. Durably bound, indexed and illustrated. Make a right beginning by sending for this book.

FLEMING BROS., Chemists
 77 Church St. Toronto, Ont.

Make Your Own Tile



Cost \$4.00 to \$6.00 per 1,000

Hand or Power

Send for catalog.

Farmers' Cement Tile Machine Co.
 Walkerville, Ont.

The London Engine Supplies Co. LIMITED

will have their next illustrated advertisement in Dec. 9. Last big advertisement was on page 1818 of November 18.

Walnut Grove Holsteins

Herd headed by May Echo Champion, full brother of May Echo Slysie, who made 36lbs. of butter in seven days. Females for sale from one year old upwards. Prices right for quick sale.

C. R. JAMES Langstaff P.O. Ontario
 Phone Thornhill.

Holsteins Cotswolds and Yorkshires

A sample of Minster Farm's offering a young bull whose Jr. 2 year old dam in R. O. P. and sire's 4 year old dam average 14,546 lbs. milk 1 year and heifers from R. O. P. cows. Also swine of both sex. For full particulars, Write:

RICHARD HONEY & SONS,
 R. R. No. 1, DARTFORD, ONTARIO

RIDGE DALE HOLSTEINS For Sale. One bull calf ready for service, and 3 young bulls, one of them sired by King Segis Pontiac Duplicate; also 2 young cows. Prices low for quick sale. R. W. Walker & Sons, R. R. No. 4, Port Perry, Ont. Manchester, G.T.R.; Myrtle, C.P.R. Bell Phone

For Sale Registered Holstein calf one year, half white, son of "Prince Abbekerk Mercens" grand champion at Ottawa and Toronto 1913.

H. KEMBER, Sarnia, Ont.

Pedigreed Holstein Bull

for sale, 15 months old. Apply **BEROLD'S FARMS** Beamsville, Ont.

Sunday. I must say here that I am sorry they did eat their potatoes in his county, because the District Representative, if he is anything like our Representative, spent a good deal of trouble getting pure seed for the pupils. However, I do not think that it was the children's wish that the potatoes were eaten. I will venture to say that 90 per cent. of the school children of our county are saving some select seed of their plots for next year. Then, let me touch on the stock-judging competitions that are being held at these School Fairs. Is not the father very proud of his son when he has won one of these prizes, but the father is not allowed to do the judging for that boy? True, the father can teach the boy, and he would be a poor father who did not, but unless the boy has the ability to see the points of an animal and the interest to look for them, he will never win, no matter how hard the rest of the family try to do so for him. The interest in stock will always stay with that boy, even if he feeds his prize oats to the chickens the next day, which I am sure will not be the case. Don't misunderstand me and think that all children will be interested in farming just because they have a School Fair, but it is well worth the trial, because 75 per cent. of the pupils will become interested. I know how a boy becomes interested in his prizewinning, for it is not so many years since I had a book-sack over my own shoulder.

The suggestion as to teaching the teachers agriculture is all right. But will teachers all become interested? I estimated that 75 per cent. of the pupils would become interested. We certainly cannot estimate the teachers any higher. What will happen to the schools where the 25 per cent. of disinterested teachers are engaged?

I have only stated facts, and we all know that it is facts that count. Let me say that I hope the teacher and the preacher become good friends, and join my worthy upholder of things that tend toward better farming, and, along with the Trustees, Inspector and District Representative, make the Fair of 1916 a success. Do all you can for your District Representative, and I am quite sure you will prosper.

ARCHIE D. LIMON,
 Middlesex Co., Ont.

Gossip.

The attention of our readers is directed to a new advertisement in this issue, being the offering of Chester White pigs, the property of John Pollard, R. R. 4, Norwich, Ont. They are a good lot, from first-class sows, and the stock boar, "Sunny Joe," a good sire and sure stock-getter. See the advertisement.

H. BOLLERT'S HOLSTEIN SALE.

Among the fifty head of Holsteins to be sold at H. Bollert's dispersion sale on Thursday, December 9, are thirty heifers, two years old and under, sired by the intensely bred bulls King Lyons Hengerveld and King Lyons Colantha. Of the former, a few words relative to his great breeding will suffice. Both his sire and grandsire have 30-lb. dams that have produced 30-lb. daughters. His dam is a 28.92-lb. daughter of Blanche Lyons Netherland. She and her grandam are the only two cows in the world to produce four daughters each with records averaging 30 lbs. Every sire and every dam in his pedigree have proven their power of transmitting big production. Of the latter bull, it is only necessary to say that he is backed up by no less than seventeen former world's champions, and that his sires have produced twenty-seven 30-lb. cows. Among the ten mature cows, two are daughters and two granddaughters of Sir Netherland De Kol Abbekerk, which has two 30-lb. and several 25-lb. daughters. He is a son of the great Tidy Abbekerk. Others again are daughters of Sir Abbekerk De Kol 2nd, which has a 32.59-lb. daughter, a 28.35-lb. sister, a 28.44-lb. half-sister, and two brothers which have 30-lb. daughters. Four of the cows are granddaughters and three others are great-granddaughters of Tidy Abbekerk. The only cow in the world that has produced three sons that have sired 30-lb. daughters.

Beautiful Walls For Your Home

Sanitary, Fire-Proof, Inexpensive



Make your home more attractive, and protect it from fire with these beautiful, sanitary

"Metallic" Ceilings and Walls

They will out-last the building and are very inexpensive. They can be brightened from year to year with a little paint at a trifling cost. Made in innumerable beautiful designs suitable to all styles of rooms. Can be erected over old plaster as well as in new buildings. Write for catalogue.

We manufacture a complete line of Sheet Metal Building Materials.

THE METALLIC ROOFING CO., LIMITED
 Manufacturers
 King and Dufferin Sts., TORONTO 797 Notre Dame Ave., WINNIPEG

Dispersion of the Maple Grove Holsteins

Failing health has forced Mr. H. Bollert, of Tavistock, Ont., to sell his renowned Maple Grove herd of richly-bred and high-producing Holsteins. Therefore on

THURSDAY, DECEMBER 9th, 1915
 AT THE FARM, NEAR TAVISTOCK, IN OXFORD COUNTY
 the entire herd of 50 HEAD will go by auction to the highest bidder.

40 Females. 10 Young Bulls

Of the females, 30 are heifers under two years of age. They are chuck full of 30-pound blood; four are g. daughters of the great Tidy Abbekerk, three are g. g. daughters. High official records are the order among the mature cows. For full particulars write for catalogue to

H. BOLLERT, TAVISTOCK, ONT., R. R. No. 1
 and mention Farmer's Advocate. Terms: Cash, or 8 months' on bankable paper, with 6%. All-morning trains will be met at Tavistock and New Hamburg.

T. MERRITT MOORE, SPRINGFIELD, AUCTIONEER.

HOLSTEINS

Joe yearling bull by King Segis Pontiac Duplicate, whose dam is a g. daughter of King Segis; 18 bulls under a year old, one from a 29-lb. cow and sired by a son of Pontiac Korndyke. Females any age.

R. M. HOLTBY
 R. R. 4 PORT PERRY, ONT.

Ask for **GOOD LUCK Calf Meal** Brand
MAKES HEALTHY, VIGOROUS CALVES
 Write for prices and sample
CRAMPSEY & KELLY
 Dovercourt Rd., Toronto

Holstein Cattle

Canary Mercedes Piertje Hartog 7th heads our herd. His dam gave 116 lbs. milk in one day and 6,197 in sixty days and made 34.60 lbs. butter in 7 days. There are more cows in our herd giving over one hundred lbs. of milk a day than any other in Ontario. We have both bulls and heifers for sale.

D. C. FLATT & SON, R. R. No. 2, HAMILTON, ONTARIO
 Long-distance Telephone

HOLSTEIN CATTLE Pure-bred cows, heifers, and heifer calves. 66 HEAD MUST BE SOLD, having disposed of my two stock farms. Come and make your selection. Price and terms to suit. Cattle will be in good working shape, not forced or fitted for sale purposes.

HAMILTON FARMS, SOUTHERN P.O., ONT.
 Telegraph and Phone Niagara Falls. Farms 10 minutes trolley from Niagara Falls.

Evergreen Stock Farm—REGISTERED HOLSTEINS

Present offering: Several bull and heifer calves, also a few yearling heifers bred and ready to breed. Write for prices and descriptions. Bell phone.

A. E. Hulet, Norwich, Ont.

Ourvilla Holstein Herd If you are starting a herd, or wanting to improve one, look at these young sires for sale, from Homestead Susie Colantha, at three years 26.60; Ourvilla Susie Abbekerk, at three years 26.02; Ourvilla Calamity Ormsby, 22.14 at three years; Homestead Helton Abbekerk, at three years 23.51, and a few others. Also come and make a selection in choice females from our herd of 100 head.

LIDLAW BROS., Aylmer, Ont.

PIONEER FARM HOLSTEINS

Bulls nearly ready for service from daughters of Prince Aaggie Mechthilde whose first junior two year old daughters averaged 14,600 lbs. milk, 656 lbs. butter in R.O.P., and five juniors now in R.O.P. test have averaged 10,893 lbs., have nearly four months to complete records and still giving from 40 to 50 lbs. each daily. For prices write

WALBURN RIVERS, R.R. No. 5, Ingersoll, Ont.

HOLSTEINS Do you want a young herd header backed up by generations of record-makers, g. sons of an ex-world champion? If so, write me. Am now booking orders for Hampshire and Chester White Swine.

C. E. KETTLE, Wilsonville P.O., Ontario
 Long-distance telephone from Waterford.

Lakeview Stock Farm Bronte, Ont. BREEDERS OF HIGH TESTING HOLSTEIN-FRIESIAN CATTLE OFFER FOR SALE A FOUNDATION HERD consisting of 1 male and 3 females all bred in the purple and backed by officially tested dams. Terms to suit purchasers.

T. A. DAWSON, Manager.

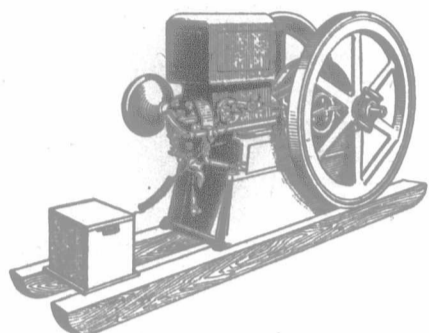

"Nearly Knocked Him Off His Balance"

A man named Trainer, at Rockcroft, Ontario has just written us this letter:-

"Dear Sirs:-

I enclose draft in payment for engine. I think it will prove itself a success.

I had an agent looking at it. He praised it every way until he asked the price - that nearly knocked him off his balance. I noticed in your directions for running engine, you mention kerosene. Will this engine run on Kerosene?"

Note that the amazement of our competitor's agent over the low price of the Page, came after he had noted the superiorities of the Page. It is not price alone on which these engines sell, but high quality plus low price.

All Page engines make good.

They are so simple that there's nothing to get out of order. Simple, yet powerful. All Page engines have power greater than their rating.

All Page engines are put to a rigid test before they are shipped.

Then—to make assurance doubly sure—we protect you still further when you buy a Page—with our unconditional guarantee—"Absolute satisfaction or your money back."

Large output, economical factory methods, and doing business on a cash basis from factory direct to you—these features enable us to sell engines at about half the price you pay (per horse power) elsewhere.

Here are the Page figures;—

1 3/4 H.-P.	- - -	\$ 46.50
3 H.-P.	- - -	68.00
5 H.-P.	- - -	113.50
6 H.-P.	- - -	168.00

If you have any remaining doubt about the profitableness of having a Gas Engine on your farm, write our Free Information Bureau and let us tell you some important facts that show what an engine will do for your farm.

As to the proof about the Page Engine in particular, there is a simple way to get at that—let us send you one to use for 30 days on our special free trial offer.

Write to our Information Bureau, explaining what size farm you have, what class of farming you do, and stating whether you've ever had experience with a gas engine.

Promptly we'll write you, explaining what an engine will do for you—what size engine you should have—and how to use it for the greatest profit.

Address:

FARM POWER INFORMATION BUREAU.

THE PAGE WIRE FENCE COMPANY
LIMITED

1137 King Street, West, Toronto.

Wire Fence, Concrete Reinforcement, Wood Saws, Farm Trucks, Feed Grinders, Pumping Outfits, Roofing, Marine Engines, Etc., Etc.,

Questions and Answers. Miscellaneous.

Black Head in Turkeys.

Turkeys have, from September, been suffering from some disease which is gradually thinning out the flock. First they appear languid, and don't keep up with the rest, then they lose their desire for food. Their droppings become very yellow in part, which turns in time to diarrhea. This gradually weakens them until they die. Most of them seem to have a burning thirst. Upon opening the dead ones, they were found to have lump-like growths on their liver. These lumps on the surface were yellowish in color, round, hard, and extended through to the opposite side. Is it likely that those which appear perfectly healthy now would have these lumps? What should be done with them?

L. J. T.

Ans.—This disease is a severe outbreak of blackhead, which affects both turkeys and fowl. The disease is bacterial, and once it becomes established it is practically impossible to treat other than by destroying diseased birds. Muriatic and hydrochloric acids can be used in the drinking water at the rate of one dessertspoonful of either one of the acids to one quart of drinking water, compelling the birds, if possible, to drink this and no other. This, however, is only a preventative, and while in some cases where the disease attack is mild a cure has been effected, yet it cannot be recommended as a cure. Giving the birds sour buttermilk or sour skim milk acts much in the same manner. F. N. M.

A Cesspool.

I would like to obtain advice as to how to build or make a cesspool. This tank is to be round, four feet in diameter and six feet deep.

1. How far from the house should it be placed?
2. What slope should be given to the drainage tile? Tank would be about 150 feet from the drain.
3. How much material (gravel, cement, etc.), would be required? F. X. E.

Ans.—1, 2 and 3. A cesspool is essentially a hole dug in the ground where sewage and effluent from the house undergo decomposition and fermentation, and the resulting liquids percolate away into the soil. A cesspool that is made water-tight would not serve the purpose. If a drain were connected with it, it would probably carry the liquids away, but we fear that tile led from the surface of this cesspool would become clogged sooner or later with solids. If placed near the bottom it would become clogged in a short time. A cesspool works most effectively on light, sandy soil, where the water can seep away easily and there is not much danger of the layers between the particles of soil becoming clogged. We would not advise our correspondent to make a cesspool such as he describes. Where the land is suitable, one six or seven feet in diameter by six or eight feet deep would do the work. Sewage disposal on the farm was discussed in an article in our issue of March 25, 1915. Other articles have appeared in this paper subsequently, but the former article was illustrated, showing septic tanks and describing minutely several methods of disposing of farm sewage.

Veterinary.

Feeding Carrots—Difficult Urination.

1. How many pounds of carrots for each 100 lbs. of weight should an idle horse be given daily during the winter?
2. Horse has trouble urinating. D. H. C.

Ans.—1. About two pounds.
2. If the trouble is due to calculi (stones) in the bladder, nothing can be done unless a veterinarian could operate. Operations for this trouble are very critical and seldom successful. If the trouble is due to a foul sheath and prepuce, relief can be given by washing out well with warm water and soap. It will be wise to have him examined by a veterinarian, who will be able to diagnose the cause of the trouble, and probably treat successfully. V.

ALWAYS WINS
field competitions because of
its wonderful capacity

See The
"Bissell"

Disc Harrow in action and
you'll buy no other. Write for
Harrow Catalog to Dept. W
T. E. Bissell Co., Limited
Elora, Ontario

Alderley Edge Ayrshire cattle and
Yorkshire swine.
Both sexes.
J. R. KENNEDY, Knowlton, Que.
Boy readers can earn a little Christmas
money by winning special classes limited
to boy feeders at the Toronto Fat Stock
Show. This show also carries classes
limited to farmers. The Secretary will
be glad to mail prize list on application.



Glenhurst Ayrshires For 50 years I have been breeding the great
Flos tribe of Ayrshires, dozens of them have
been 60-lb. cows; I have lots of them get 60 lbs a day on twice-a-day milking. Young
bulls 1 to 10 months of age, females all ages. If this kind of production appeals to you
write me

James Benning, Williamstown Ont.

Stonehouse Ayrshires
Hector Gordon, Howick, Que.

Are a combination of show-yard and utility
type seldom seen in any one herd. A few
choice young males and females for sale.
Write or phone your wants to Stonehouse
before purchasing elsewhere.

HILLHOUSE Show-ring winners. Dairy test winners. 75 head to select
from. Bull calves and females of all ages for sale. Before
buying, come and inspect our herd and get prices.
AYRSHIRES F. H. Harris, Mt. Elgin, Ontario

Gladden Hill Ayrshires Present offering: Our stock bull, Tam O' Menie = 35101 =
dam. Dewdrop of Menie = 25875 =, R. O. P. test 9,783
lbs. milk, 401 lbs. butter-fat as a 3-year-old. This bull
stood 3rd at Toronto this year. Also young bulls from record cows, and females of all ages.
LAURIE BROS., R.R. No. 1 Agincourt Ont.

Humeshaugh Ayrshires We have several February, March and
April, 1915, bull calves, bred from some
of our best imported and home-bred
females, which we offer at
good value for quick sale.
Alex. Hume & Co., Campbellford, Ont., R.No.3

Brampton Jerseys We are busy. Sales were never more abundant. Our
cows on yearly test never did better. We have some
bulls for sale from Record of Performance cows. These
bulls are fit for any show ring.
B. H. BULL & SON,
BRAMPTON, ONTARIO

NOVEMBER 1915

Makes
Makes
The cost
Gardiner's Ova
your flock wo
extra egg per
The gain
will average s
Very often,
Ovatum will
duction from
been laying at
This it do
digestion and
organs, so th
good out of t
of it into egg
It will cert
Ovatum. Ge
in 25c. and 5
bags. If he
prices on Ova
Cotton Seed
Meal and Cal
GARDIN
Feed Special

The S
Good B
Win
Dairy
Made

Cedar Posts Can
7 in
by 8 ft. 18c., 7 ins. and
etc. Terms—Cash.
Box 52, G

SU
Flock es
by the la
ewes in
recorded
handled
PETER
Teeswat

CHOICE L
Good stock of both sex
for prices, etc.
C. & E. WOOD, Fr

Oxford Downs
year to supply Oxford D
choice Ram Lamb, also
Wm. Barnet & Sons, I

Tower Farm Ox
shearing rams and ewes
bred from imported
See winnings at Toron
Hillsburgh Stations. Lo
R. BARBOUR R. R.

SHROPSHIRE A
Our Shropshire lambs thi
an extra lot, well grow
balanced. They are for
the bred Shorthorns, you
P. Christie & Son, Ma

For Sale—A few
Lambs,
Martin N. To

Questions and Answers. Miscellaneous.

Black Head in Turkeys. I have, from September, been... from some disease which is... thinning out the flock. First... near languid, and don't keep up... rest, then they lose their de... food. Their droppings become... low in part, which turns in time... sea. This gradually weakens... all they die. Most of them seem... a burning thirst. Upon open... dead ones, they were found to... up-like growths on their liver... ups on the surface were yellow... color, round, hard, and extended... to the opposite side. Is it... at those which appear perfectly... how would have these lumps?...

L. J. T. This disease is a severe outbreak... head, which affects both turkeys... The disease is bacterial, and... becomes established it is prac... possible to treat other than by... diseased birds. Muriatic and... eric acids can be used in the... water at the rate of one desul... of either one of the acids to... of drinking water, compelling... if possible, to drink this and... This, however, is only a pre... and while in some cases where... see attack is mild a cure has... ted, yet it cannot be recom... s a cure. Giving the birds... er milk or sour skim milk acts... the same manner. F. N. M.

A Cesspool. I like to obtain advice as to... build or make a cesspool. This... be round, four feet in diam... six feet deep.

How far from the house should it... slope should be given to the... tile? Tank would be about... om the drain.

How much material (gravel, cement... be required? F. X. E.

2 and 3. A cesspool is a hole dug in the ground... ge and effluent from the house... composition and fermentation... sulting liquids percolate away... il. A cesspool that is made... would not serve the purpose... n were connected with it, it... ably carry the liquids away... r that tile led from the sur... his cesspool would become... ner or later with solids. If... the bottom it would become... a short time. A cesspool... t effectively on light, sandy... the water can seep away... there is not much danger of... between the particles of soil... ogged. We would not advise... ondent to make a cesspool... describes. Where the land is... a six or seven feet in diam... or eight feet deep would do... Sewage disposal on the... discussed in an article in our... ch 25, 1915. Other articles... ed in this paper subsequently... rmer article was illustrated... tic tanks and describing... eral methods of disposing of...

Veterinary.

Problems—Difficult Urination. Many pounds of carrots for... of weight should an idle... en daily during the winter?... as trouble urinating. D. H. C.

about two pounds. trouble is due to calculi... the bladder, nothing can... a veterinarian could operate... or this trouble are very... seldom successful. If the... to a foul sheath and prepuce... given by washing out well... water and soap. It will be... him examined by a veteri... will be able to diagnose the... trouble, and probably treat... V.



Makes Hens Pay, for it Makes Them Lay!

The cost of a daily ration of Gardiner's Ovatum for every hen in your flock would be covered by one extra egg per hen per month.

The gain from feeding Ovatum will average several times that much. Very often, especially in winter, Ovatum will start a good daily production from a flock that has not been laying at all.

This it does by invigorating the digestion and the reproductive organs, so that the hens get more good out of their feed, and turn more of it into eggs.

It will certainly pay you to feed Ovatum. Get it from your dealer in 25c. and 50c. packages or 10-lb. bags. If he hasn't it, write us for prices on Ovatum, Ontario Feeders' Cotton Seed Meal, Sac-a-Fat, Pig Meal and Calf Meal.

GARDINER BROS., Feed Specialists, SARNIA, Ont.

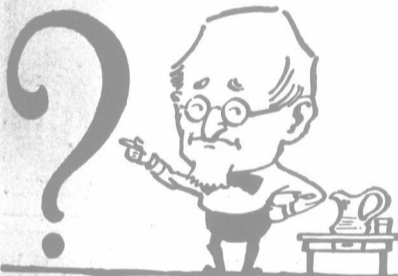

The Secret of Good Butter is Windsor Dairy Salt Made in Canada

Cedar Posts Car Lots Green 4 1/2 ins. under 7 ins. by 8 ft. 9c., 7 ins. and up by 8 ft. 18c., 7 ins. and up by 9 ft., 22c. All bar... Terms—Cash. Stamps for replies. Box 52, Gooderham, Ont

SUMMER HILL OXFORDS

Flock established many years ago by the late Peter Arkell. Rams and ewes in any quantity for sale, all recorded. Positively no grades handled except by order. PETER ARKELL & CO. Prop. Teeswater Ont., C.P.R., Box 454.

CHOICE LEICESTERS

Good stock of both sexes, different ages. Write for prices, etc. G. & E. WOOD, Freeman Ont: Bell Phone

Oxford Downs—We are in a particularly favorable position this year to supply Oxford Down breeders with a right choice Ram Lamb, also Ewe Lambs. Wm. Barnet & Sons, R.R. No. 3, Fergus, Ont.

Tower Farm Oxford Sheep. Champion flock of Canada. Choice shearing rams and ewes, also ram and ewe lambs bred from imported and prize-winning stock. See winnings at Toronto and Ottawa. Erin or Hillsburgh Stations. Long-distance Phone. R. BARBOUR R. R. 2, Hillsburgh, Ontario

SHROPSHIRE AND SHORTHORNS Our Shropshire lambs this year by a Butter ram are an extra lot, well grown well covered and well balanced. They are for sale, both sexes, also milk-bred Shorthorns, young bulls, cows and heifers. F. Christie & Son, Manchester, Sta. and F.O.

For Sale—A few Horned Dorset Ram Lambs, from 6 to 9 months old. Martin N. Todd, Galt, Ont.

Questions and Answers. Miscellaneous.

About Top Dressing and Plowing Sod.

1. I have a number of young cattle which I am going to fatten for sale, and intend to feed cottonseed meal, corn meal, and shorts. How should those be divided to make a balanced ration? For roughage, I will feed clover hay, cornstalks, and silage. Is there anything else I could feed that would be a benefit?

2. Could you give me the address of any farmer who might have Ontario variegated alfalfa seed for sale?

3. I have a field of hard clay which I have just plowed. I have not been used to clay. It is quite lumpy. I plowed it about one foot deep. I intend to top dress with manure before I sow to oats. When would be the best time to apply the manure, now or after it freezes up, or would it be better in the spring?

4. When would be the proper time to apply leached ashes to the soil? I have a field of a sandy loam broke out of the sod. Would it be well to apply soon, or in the spring on this field? What benefit may I expect from the leached ashes, as they have been in a pile since the potash days, 60 or 70 years ago?

5. I have about 25 loads of fresh manure to spread. How would it do to spread on a sod field and plow down this fall, and work up before it freezes up? The field will be planted to corn. Would it be advisable to leave it until spring? J. E. M.

Ans.—1. The grain ration mentioned here does not seem the most economical for a farmer to feed. It should not be necessary to purchase shorts, although a little cottonseed meal might be economically used. However, in feeding the grains mentioned by our correspondent, one would naturally start with a small ration of corn meal and shorts, with a very little cottonseed meal added. Cattle do not take to cottonseed meal at first. They have to be educated to eat it. As time goes on the amount of cottonseed meal can be increased to a couple of pounds per day, but it is not probable that the price will warrant feeding any more than that amount per day this winter. Corn meal is the grain which should be depended upon here to produce the actual results, but a pound of shorts, or even two pounds, can be added per day. It would be impossible to stipulate the total amounts of grain to feed, as it will depend upon the size of the animals and their ability to consume feed. Practical feeders of cattle do not bother so much about balanced rations as do dairymen. The weights of milk and butter will indicate to a dairyman whether he is getting good results or not, but the cattle feeder must depend upon his eye largely to furnish him with the necessary information as to the way in which his cattle are thriving.

2. Any farmers who have Ontario variegated alfalfa seed for sale should advertise in these columns.

3. Land which is very lumpy, as our correspondent has described, should be better left without any top dressing until it is harrowed. The frost should have every access to these lumps, so they will be easily broken up in the spring. It has been found on clay land that a top dressing of manure will often retain the moisture of the surface layers, and thus belate cultivation in the spring. We would advise spreading the manure in the spring after the land is dry enough to carry the loads.

4. After 60 or 70 years exposed to the weather we would not expect these ashes to contain very much potash. However, they would still contain some lime. They could be sown upon the land when it was most convenient for the farmer.

5. Any work that can be done in the fall will lessen the rush of spring seeding, and for some crops hawking the manure this fall and plowing would be all right, but for corn, it depends very much upon local conditions. Some have found that spring plowing gives better crops, while others prefer to plow the land in the fall. All plowing possible should be done this autumn, for it will improve the land and make less to do in the spring. Previous experience will probably answer this question for our enquirer.

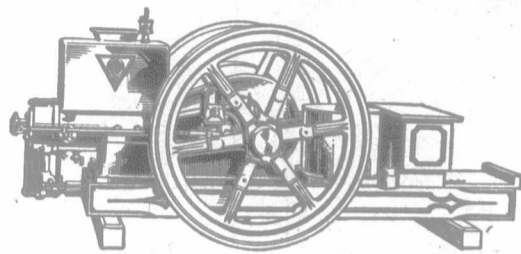

Alpha Engine Facts

Alpha Engines are reliable. Use all fuels. Are easy to start. Develop full power. Are free from vibration. Have best pulley arrangement. Have simple, reliable ignition. Are thoroughly standardized, and parts are interchangeable. Strictly modern in design. Are high-class in appearance. Will fit your needs for size and equipment. Make best showing when directly compared with other engines. Are sold and backed by a Company that has a world-wide reputation for selling only high-quality machines and equipment.

An ideal engine for farm use

Eleven sizes, 2 to 28 horse-power. Each furnished in stationary, semi-portable, or portable style, and with either hopper or tank cooled cylinder.

Every farmer needs an "Alpha." Send for catalogue.

DE LAVAL DAIRY SUPPLY CO., LTD.

LARGEST MANUFACTURERS OF DAIRY SUPPLIES IN CANADA MONTREAL PETERBORO WINNIPEG VANCOUVER

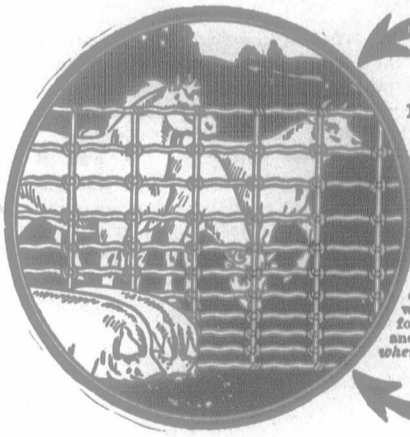

Peerless Perfection

Made in Canada. Quality worthy of the name and Nation. A fence of defence—never gives offence.

The Fence That's Looked Together

The attacks and onslaughts of animals can't face it. It's strong, yet springy. Manufactured from Open Hearth steel galvanized wire. When made by this process, impurities are burned out of the metal, removing one of the chief causes of rapid corrosion or rusting. If you are considering the fence question, let us estimate on your job—and advise with you as to the best way to build—we will put you in touch with our nearest agent. Send for our latest catalog. Ask about our poultry fencing and ornamental gates. Agencies nearby everywhere. Agents wanted in open territory. THE DANWELL-NOXIE WIRE FENCE CO., Ltd., Winnipeg, Man., Hamilton, Ont.

H. ARKELL W. J. ARKELL F. S. ARKELL

Summer Hill Stock Farm

Largest and oldest importers and breeders of

OXFORDS

in Canada. Look up our show record, it will give you an idea of the kind of Oxfords we have for sale.

Peter Arkell & Sons, Proprietors, Teeswater, Ontario Customers, beware of imitations of this advertisement.

Farnham Farm Oxford and Hampshire Downs

Flock Established in 1881 from the best flocks in England. We are offering a splendid lot of yearling rams and ram lambs for stock headers or show purposes. We ourselves have retired from the show-ring so hold nothing back. We are also offering 80 yearling Oxford ewes and ewe lambs; a few superior Hampshire yearlings and ram lambs. All registered. Prices reasonable. HENRY ARKELL & SON, Route 2 GUELPH, ONT Guelph, G.T.R.; Arkell, C.P.R. Telegraph Guelph. Long-distance phone in house.

SPRING VALLEY SHROPSHIRE

Shearing Rams, Shearing Ewes, Ram Lambs, Ewe Lambs. Sired by a Milne's Ram (Imported). Let me quote you prices. THOS. HALL, R. R. No. 3 BRADFORD, ONT.

Shropshires and Cotswolds for Sale—Yearling rams and yearling ewes, a few imported 3 shear ewes, an extra good lot of ram lambs from imported ewes. I expect an importation of rams of both breeds from England 1st. of August. Prices very reasonable. JOHN MILLER, Claremont, Ont. Claremont, C. P. R., 3 miles. Pickering, G. T. R., 7 miles. Greenburn, C. N. R., 4 miles.

OAK - LODGE SHROPSHIRE

We have on hand for sale a large number of Shearing Rams and Shearing Ewes, Ram and Ewe lambs, got by noted sires that have produced winners at Toronto for the last 3 years, highest quality. J. E. Brethour & Nephew Burford, Ontario

Home, Sweet Home

THE most beautiful thing in the world to-day is the home life which has been developed.

But life insurance should be carried so that in the event of the father's death the family will not be compelled to forsake the old place for one less comfortable. The Mutual Life of Canada prides itself on being

the Company that makes Canadian homes—
the Company that protects Canadian homes—
the Company that maintains Canadian homes.

Provide against the loss of the old home in the event of your death by means of a policy in

THE MUTUAL LIFE ASSURANCE COMPANY OF CANADA
WATERLOO, ONTARIO

108

PATENTS TRADE MARKS and DESIGNS
PROCURED IN ALL COUNTRIES
Special attention given to Patent Litigation
Pamphlet sent free on application.

Ridout & Maybee
CROWN LIFE BUILDING, TORONTO, ONT.

Preston SAFE Shingles
Locked securely on four sides. Galvanized to meet the British Government test. Send for free booklets.
The Metal Shingle & Siding Company Limited
Preston Ontario

Poland-China Swine Duroc Jerseys Berkshires and Chester Whites, also Dorset Horn sheep. Young stock of both sexes. Come and see, write or phone. **CECIL STOBBS**, Leamington, Ontario Phone 284.

Tamworths Buy your breeding stock now, as they will be very scarce this fall. I have a nice lot of boars ready for service, and sows ready to breed. Prices reasonable.
Herbert German, St. George, Ontario

SUNNYSIDE STOCK FARM
Chester White Swine Champion herd at Toronto and London Fairs; also Dorset Horn Sheep, young stock of both sexes for sale.
W. E. Wright & Son, Glanworth, Ontario

Yorkshire Sows for Sale. Three choice Yorkshire sows, bred eight months old, weight about 275 lbs. L. D. Phone.
Geo. D. Fletcher, R.R. No. 1 Erin, Ont.

Tamworths Young sows bred for fall farrow and some choice young boars. Registered. Before buying write for prices.
JOHN W. TODD, R.R. No. 1, Corinth, Ont

For Sale:—Ohio Improved Chester White Swine. The oldest established registered herd in Canada. Pairs furnished not akin 6 to 8 weeks old. Write for prices.
Mrs. E. D. George & Sons, R.R. No. 2, Mossley, Ont.

Pedigreed Tamworth Boars and Sows for sale, seven weeks old. Apply **HEROLD'S FARMS** Beamsville, Ont.

Morrison Tamworths and Shorthorns, bred from the prize-winning herds of England. Choice Tamworths, both sexes, all ages, 150 head to choose from. Choice Shorthorns, 8 extra fine red roan bull calves, 8 mos. old, dandies, also cows and heifers of the deep milking strain. Chas. Currie, Morrison

CLEARVIEW CHESTER WHITES For many years my herd has won the highest honors at Toronto, London, Ottawa and Guelph. For sale are both sexes of any desired age, bred from winners and champions.
D. DeCoursey, R. R. No. 5, Mitchell, Ont.

Pine Grove Yorkshires—Bred from prize-winning stock of England and Canada. Have a choice lot of young pigs of both sexes, pairs not akin, to offer at reasonable prices. Guaranteed satisfaction.
Joseph Featherston & Son, Streetsville Ont.

ELMDALE CHESTER WHITES For immediate delivery; young pigs of excellent type, selected pairs not akin. Some sows carefully bred to best boars to be had.
JOHN POLLARD, R. No. 4, Norwich, Ont.

Dyke's Book—FREE A NEW IDEA OF TEACHING BY MAIL interesting, instructive—tells you how to learn AUTO TRADE how to become a chauffeur and repairman—SEND FOR IT—To-day—New!
ALDYKE, 93 Rue Bige St. Louis, Me. CHARTS, MANIKINS, ETC.

Questions and Answers.
Miscellaneous.

Horse Radish.
Would you kindly state, through the columns of your valuable paper, what you think a proper price for horseradish roots, stating which is the better way to sell, by weight or measure, and give prices in both cases?

FARMER'S DAUGHTER.
Ans.—A local gardener sells his at 15 cents per lb. Some sell by the bunch, putting up in small bunches of about a pound. In the United States it sells in large quantities to canning plants for from \$80 to \$100 per ton.

Sweet Clover.
I would like to know what kind of soil is best for sweet clover. I have some sandy loam and some clay loam, and the balance of my farm is a heavy gray or brown clay, with a level surface. I would like to have two fifteen-acre fields of the clay land for pasture, and would like some information as to what class of soil is best adapted to the production of sweet clover. R. T.

Ans.—Sweet clover should do very well on any of these soils. We have seen it growing luxuriantly on almost all kinds of soil, and your clay land should produce a good yield. Sow about 20 lbs. per acre. Of course, it will not do the best on wet, poorly-drained soil.

Eveners for Riding Plough;
Is there an evener for four horses on a riding plow arranged so as to keep three on land and one in furrow? Please send the dimensions if there is any. The plow has a tongue which is between the horse in the furrow and the one next. I want to drive four abreast.
E. C. W.

Ans.—The accompanying cut illustrates a method of arranging eveners for this purpose. It was sent in by a correspondent, and we invite readers having other such eveners to describe them through these columns. A and B are whiffletrees such as are used on any implement; C is a strong doubletree, 5 feet 4 inches long, and from right end to center of first pulley is 7 inches. From

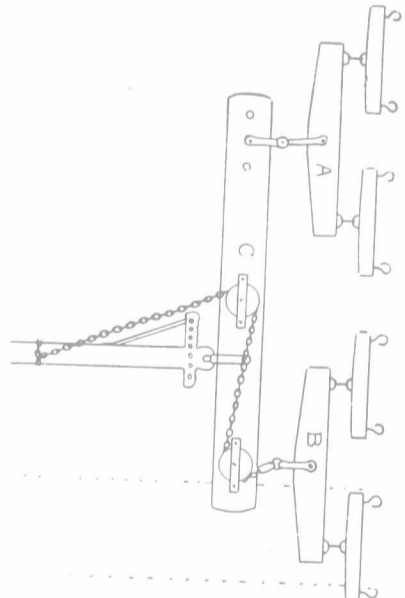

center of first pulley to where plow-head clevis fastens, is 15 1/4 inches. Also, from center of first pulley to center of second pulley is 24 inches. At left end of doubletree, C, bore three holes, first one 2 1/2 inches from end, second hole 2 inches from first one, and third hole 2 inches farther on, and fasten clevis in whichever one is found to be best. The chain passing through the pulleys will work more satisfactorily if links are not too large, one end being attached to B, and the other end can be wrapped around beam of plow at any convenient place, usually where the coulter is, and must be hitched up fairly tight, so that there will not be too much slack when turning to the left. It is claimed that this evener works without any side-draft.

Herr Doctor—"Your Majesty is much run down. You need a sea voyage."
The Kaiser (bitterly)—"Vere can I go—de Aquarium?"—EX.



Winter Hauling Made Easy

FOR the use of our customers whose hauling cannot be stopped by the snows of winter, or to whom the snows are welcome, as furnishing a smooth hard road over which to move their products, we offer a line of bob sleighs so complete that each man may find in it the kind of sleigh he needs and uses.

Unless a sleigh will stand hard knocks, it is of little value in Canada. Therefore, we make these sleighs, above all else, strong. Even the lightest one-horse sleighs are as strong as selected pieces of high-grade wood and steel and the most careful workmanship can make them. No imperfect or unsound material finds its way into the manufacture of these goods.

Each sleigh we sell is guaranteed, with fair usage, to carry its load over ordinary roads and to do the work intended for its size. We make a liberal guarantee arrangement to take care of the satisfaction of our customers.

See our line before you buy. It is handled by I H C local agent who will show you how big a line it is. Or, if you cannot conveniently see the agent, drop a line to the nearest branch house and we will send full information.

International Harvester Company of Canada, Ltd.
BRANCH HOUSES
At Brandon, Calgary, Edmonton, Estevan, Hamilton, Lethbridge, London, Montreal, N. Battleford, Ottawa, Quebec, Regina, Saskatoon, St. John, Winnipeg, Yorkton

Don't Wait Until You Feel Old
OR SICK BEFORE YOU APPLY FOR AN
EXCELSIOR ENDOWMENT
WHICH WILL
Protect the Home — Provide for Old Age
THE EXCELSIOR LIFE INSURANCE CO.
"SECURITY FIRST"
\$137 of Assets for each \$100 of Liability

Head Office: TORONTO, CAN.

Yorkshire Pigs
AGES FROM FOUR WEEKS TO SEVEN MONTHS.
Strong growthy individuals from well bred sire and dams. Inspection invited. Address—
Weldwood Farm
Farmer's Advocate, London, Ontario

ELMHURST LARGE ENGLISH BERKSHIRES
From our recent importation of sows, together with the stock boar, Suddon Torredor we can supply select breeding stock, all ages. Satisfaction and safe delivery guaranteed
H. M. VANDERLIP, Breeder and Importer, R.R. 1 BRANTFORD, ONTARIO
Langford Station on Brantford & Hamilton Radial.

DUROC JERSEY SWINE, JERSEY CATTLE
In Duroc Jerseys we have either sex of any desired age, bred from winners and champions for generations back. In Jerseys we have young cows in calf and young bulls, high in quality and high in producing blood.
MAC. CAMPBELL & SONS NORTHWOOD, ONT.

Yorkshire Sale Do It Now. Make your choice. SPECIAL PRICES from Nov. 18th. to Dec. 18th. Will pay one way fare on purchase of \$60.00 and over. Shropshire rams also. Inspection invited.
Wm. Manning & Sons, Woodville, Ontario

Newcastle Tamworths and Shorthorns Boars ready for service. Sows due to breed and a lot of both sexes ready to wean. Descendants of imp. and championship stock. Several extra choice young bulls and heifer calves, recently dropped; grand milking strain, 2 bulls 5 and 8 months old. All at reasonable prices.
A. A. COLWILL, NEWCASTLE, ONTARIO Long-Distance Telephone

Cloverdale Large English Berkshires!
Sows bred, others ready to breed; boars ready for service; younger stock, both sexes, pairs not akin. All breeding stock imp. or from imp. stock. Prices reasonable.
C. J. Lang, Burketon, Ont. R. R. 3.

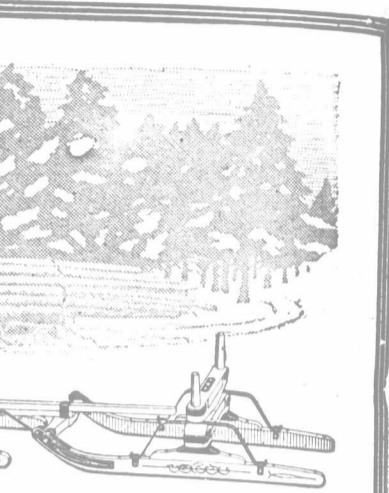

Made Easy

Owners whose hauling snows of winter, or to furnish a smooth ride in their products, we offer at each man may find in it

knocks, it is of little value these sleighs, above all else, sleighs are as strong as steel and the most careful to imperfect or unsound nature of these goods. with fair usage, to carry the work intended for its arrangement to take care of

is handled by I H C local line it is. Or, if you can line to the nearest branch on.

any of Canada, Ltd.



Until You Feel Old
RE YOU APPLY FOR AN
ENDOWMENT
WHICH WILL
— Provide for Old Age
LIFE INSURANCE CO.
FIRST
for each \$100 of Liability

e Pigs

TO SEVEN MONTHS.
d sire and dams. Inspection

l Farm

London, Ontario

GLISH BERKSHIRES
er with the stock boar, Suddon Torredor
Satisfaction and safe delivery guaranteed
ter, R.R. 1 BRANTFORD, ONTARIO
rd & Hamilton Radial.

JERSEY CATTLE
bred from winners and champions for
all and young bulls, high in quality and
od.
NORTHWOOD, ONT.

SPECIAL PRICES from Nov. 18th. to
fare on purchase of \$60.00 and over.
Woodville, Ontario

Boars ready for service. Sows due
to farrow, others bred and ready to
of imp. and championship stock. Several
d: grand milking strain, 2 bulls 5 and 8

lish Berkshires!
ounger stock, both sexes, pairs not akin.
urketon, Ont. R. R. 3.

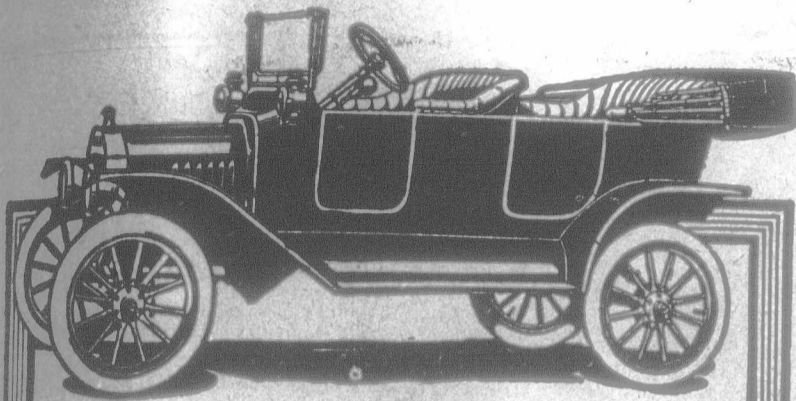

"MADE IN CANADA"

Ford Touring Car Price \$530

If you stayed indoors all winter—you might not need your Ford 'till "new grass" time. But in the wide "out-of-doors" the Ford serves as well in January as in June. It's the all-year-round car with a reputation for service and economy that isn't affected by the seasons.

The Runabout is now \$480; the Town Car \$730, f.o.b. Ford, Ontario. All cars completely equipped, including electric headlights. Equipment does not include speedometer.



We pay highest Prices For **FREE**

RAW FURS

And Remit Promptly

John Hallam Limited 313 Hallam Building TORONTO

More Trappers and Fur Collectors send their Raw Furs to us than to any other five houses in Canada. Because they know we pay highest prices, pay mail and express charges, charge no commissions, and treat our shippers right. Result, we are the largest in our line in Canada. Ship to us today and deal with a Reliable House. No Shipment too small or too large to receive our prompt attention.

We sell Guns, Rifles, Traps, Animal Bait, Shotguns, Flashlights, Headlights, Fishing Nets, Reeling Tackle and Sportsmen's Supplies at lowest prices. CATALOG FREE.

Hallam's Three Books: "Trapper's Guide" English or French 36 pages, illustrated, tells how and where to trap and other valuable information for trappers; also "Trapper's and Sportsman's Supply Book" Raw Fur Price List, and latest "Fur Style Book" of beautiful fur sets and fur garments. All these books fully illustrated and sent FREE OF CHARGE.

SHIP YOUR

RAW FURS

To the Largest, Most Reliable and Oldest House in Canada

We Pay express and postage. Prompt returns.

E. T. CARTER & CO., 84 Front Street E., TORONTO

RAW FURS

WE BUY THEM!

Thousands of satisfied shippers say we give good returns. Good reason: we pay highest market price, give honest assortments and make quick returns. It will really pay you to ship to us. We charge no commissions and pay express and mail charges. Write for free price list and shipping tags sent to trappers and dealers only.

BENJAMIN DORMAN, Inc.
167 West 24th St. RAW FURS, GIBBERO, GOLDEN SEAL New York

Make Your Own Will
In your home. No lawyer's fees
MAX CORRECT WILL FORM

Sent with full instructions and specimen will for 35c. Sold by all stationers and druggists (take no substitute) or post free from Max Will Form Co., Dept. 191, 257 College Street, Toronto.

THOUSANDS

of farms and city properties for sale or exchange. Send to us for our catalogues—Free.

A number of Western farms to exchange for Ontario property. Tell us your wants.

THE WESTERN REAL ESTATE EXCHANGE, Limited
78 Dundas St. London, Ont.

Gossip.

Lakeview Stock Farm, Bronte, Ont., in advising a change of advertisement, wish to state that, owing to the increased demand and many sales made during the past summer and fall, they will not hold their annual sale this winter as usual, but will continue to sell choice stock of either sex, for cash or on terms. Practically the whole foundation of this herd is tuberculin tested, and composed of cows producing from 100 to 110½ lbs. of milk in one day, and from 28 to 28.30 lbs. of butter in seven days. When in need of a good cow, or a herd sire, don't overlook this herd. Correspondence is solicited, and visitors are always welcome. Trains met by appointment.

Some of the young bulls offered for sale from the Ayrshire herd on Lakeside Farm, Phillipsburg, Que., come from bulls of exceptional breeding. Some sires that have been used on this herd in the past are Barcheskie Cheerful Boy, succeeded by Hobland Bonny Boy, which in turn gave place to Morton Mains Planet. The latter bull was a winner at all the leading Canadian shows as a yearling. At present the herd is headed by Auchenbrain Sealoom, which was grand champion at Quebec and Sherbrooke exhibitions this year. Among the young bulls for sale are Lakeside Spicy Hero, calved August 27, 1914. This fellow is from Record of Performance stock, and combines the blood of the Barcheskie and Morton Mains herds. Lakeside Bonny Lad is another bull with excellent breeding, and is the get of an exceptionally good heifer, which finished her period with over 10,200 lbs. to her credit in the two-year-old class. Lakeside Secretary, Lakeside Beau Brummel, Lakeside King Albert, and Lakeside Seapoy, are other young males of the herd which combine the blood of some of the best Ayrshire families, and which have for dams females which are good producers. Write for a catalogue describing these young herd-headers.

A BIG SALE OF DAIRY CATTLE.

The dairy cow is still the mainstay of the farmer, and many farmers need more dairy cows of the right kind. They can get them at Scott Bros.' sale, Hyde Park, December 8, and we advise all to look up the advertisement in this issue. The offering comprises 45 head of Holsteins, including heifers and cows which have given from 40 lbs. of milk per day up to 76 lbs. per day. There is one good registered bull in the lot, which includes 21 grade cows, all young, aged from two to seven years. The young stock is particularly promising, including seven yearling heifers bred to a good, registered bull, and eleven calves sired by that grand breeding bull, Homestead King Colantha Abbekerk 10467. Anyone desiring young stock should not miss this sale. Two-year-old heifers and cows in milk are all heavy producers, and for the most part the herd has been built up from judicious breeding and selection of heifers produced by good foundation cows. New blood was inserted from the Campbell herd, Komoka. These regular breeders, some fresh, all good producers, should attract buyers December 8. Trains will be met at Komoka, C. P. R. and G. T. R., day of sale. See the advertisement and write Scott Bros. for further particulars if desired.

THE NEW TELEPHONE TALK.

Hello, Calcutta! Canarsie wants you. I'm still ringing 9876 Shan-tung.

Never mind, Montclair! New Guinea was calling, but the party's left the booth.

Here's Chihuahua, Vladivostok! Drop one rouble at a time, please!

Listen, Kansas City! Tibet 2626 has been discontinued.

Hello, Tokio; you say you can't understand the party in Buenos Ayres? I'll have the manager put an interpretress on the line.

That b-r-r-r-r from the Glasgow Exchange is spoiling the waves!

You want the correct time? Quit your kidding, Greenwich!—New York Mail.



Synopsis of Canadian North-West Land Regulations

THE sole head of a family, or any male over 18 years old, may homestead a quarter-section of available Dominion land in Manitoba, Saskatchewan or Alberta. Applicant must appear in person at the Dominion Lands Agency or Sub-Agency for the District. Entry by proxy may be made at any Dominion Lands Agency (but not Sub-Agency), on certain conditions.

Duties—Six months residence upon and cultivation of the land in each of three years. A homesteader may live within nine miles of his homestead on a farm of at least 80 acres, on certain conditions. A habitable house is required except where residence is performed in the vicinity.

In certain districts a homesteader in good standing may pre-empt a quarter-section alongside his homestead. Price \$3.00 per acre.

Duties—Six months residence in each of three years after earning homestead patent; also 16 acres extra cultivation. Pre-emption patent may be obtained as soon as homestead patent, on certain conditions.

A settler who has exhausted his homestead right may take a purchased homestead in certain districts. Price \$3.00 per acre. Duties—Must reside six months in each of three years, cultivate 50 acres and erect a house worth \$300.

The area of cultivation is subject to reduction in case of rough, scrubby or stony land. Live stock may be substituted for cultivation under certain conditions.

W. W. CORY, C.M.G.,
Deputy of the Minister of the Interior.

N.B.—Unauthorized publication of this advertisement will not be paid for.—64388.

GRAND TRUNK RAILWAY SYSTEM

DOUBLE TRACK ALL THE WAY

TORONTO-CHICAGO TORONTO-MONTREAL

FOR CHICAGO
Leave TORONTO 8.00 a.m., 6.00 p.m., and 11.45 p.m. daily.

FOR MONTREAL
Leave TORONTO 9.00 a.m., 8.30 p.m., and 11.00 p.m. daily.
Equipment the finest on all trains.

Panama-Pacific Expositions
Reduced Fares to
San Francisco, Los Angeles and San Diego
Full particulars and berth reservations on application to Agents.

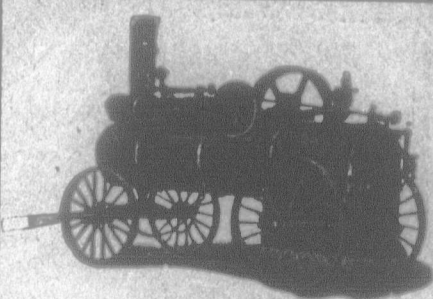

Rebuilt Portable and Traction Engines and Threshers
All sizes, for sale cheap. Complete threshing outfit, traction engine with cab, separator, wind stacker, \$875 in good operative conditions
The Robt. Bell Engine & Thresher Company, Limited
SEAFORTH, ONTARIO

DO YOU NEED FURNITURE?
Write for our large Photo-Illustrated Catalogue No. 7—it's free to you.
THE ADAMS FURNITURE CO., Limited
Toronto, Ontario

RAW FURS

Highest cash price paid for raw furs. Oldest in trade. Write for price list and tags—FREE.
C. H. ROGERS, WALKERTON, ONT.

FREE!
 Short Courses
 at the
Ontario Agricultural College
 JANUARY, 1916

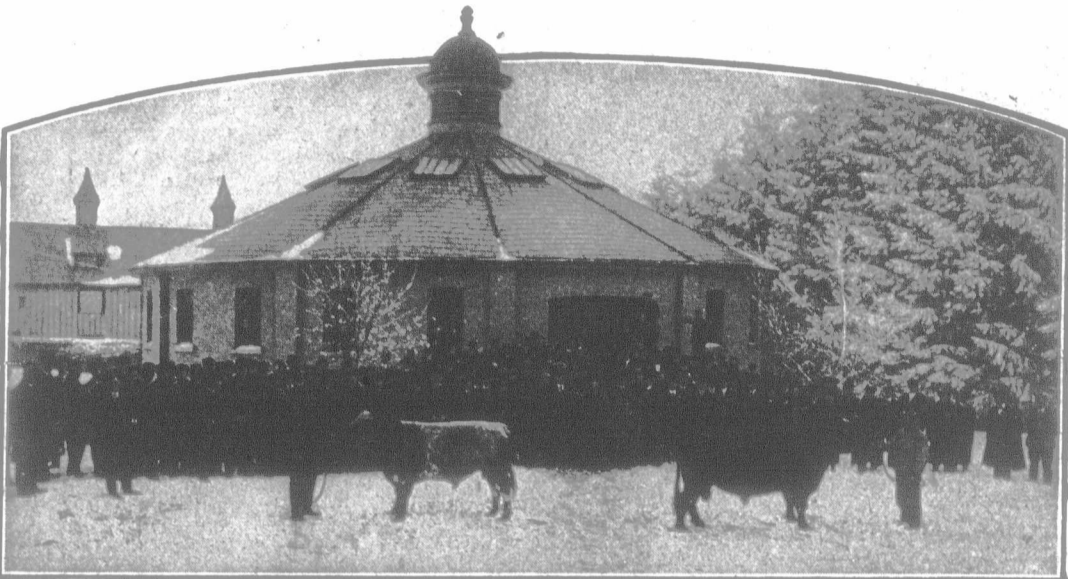

The Short Courses were instituted for **Farmers and Farmers' Sons** who cannot attend the regular courses. The only expense is board at reasonable rates and reduced railway fare.

JUDGING BEEF CATTLE.

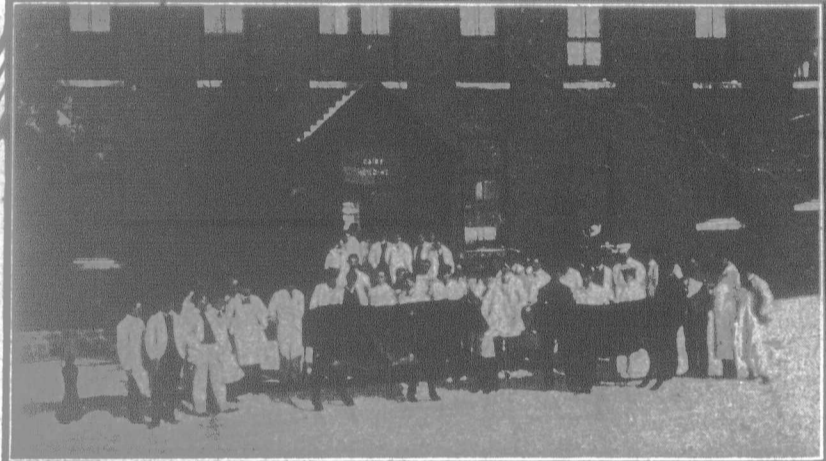

BUTTER-MAKERS.

JUDGING POULTRY.

Stock and Seed Judging
 (two weeks)
 Jan. 11 to 22

Poultry Raising
 (four weeks)
 Jan. 11 to Feb. 5



Dairying
 (three months)
 Jan. 3 to Mar. 24

Fruit Growing
 (two weeks)
 Jan. 25 to Feb. 5

Beekeeping
 (two weeks)
 Jan. 11 to 22

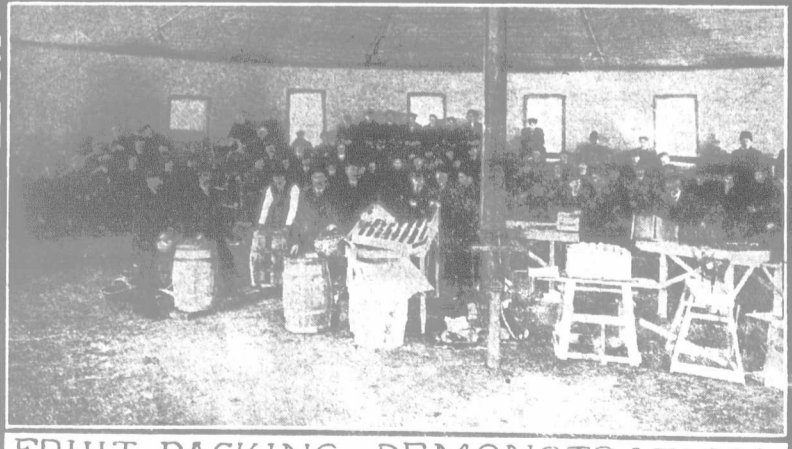

FRUIT PACKING DEMONSTRATION.

DRESSED CARCASSES.

Illustrated short course Calendar mailed upon request. Applications should be made early as the accommodation for some classes is limited.

G. C. KIRKMAN, PRESIDENT