

Technical and Bibliographic Notes / Notes techniques et bibliographiques

The Institute has attempted to obtain the best original copy available for scanning. Features of this copy which may be bibliographically unique, which may alter any of the images in the reproduction, or which may significantly change the usual method of scanning are checked below.

L'Institut a numérisé le meilleur exemplaire qu'il lui a été possible de se procurer. Les détails de cet exemplaire qui sont peut-être uniques du point de vue bibliographique, qui peuvent modifier une image reproduite, ou qui peuvent exiger une modification dans la méthode normale de numérisation sont indiqués ci-dessous.

- | | | | |
|-------------------------------------|---|-------------------------------------|---|
| <input type="checkbox"/> | Coloured covers /
Couverture de couleur | <input type="checkbox"/> | Coloured pages / Pages de couleur |
| <input type="checkbox"/> | Covers damaged /
Couverture endommagée | <input type="checkbox"/> | Pages damaged / Pages endommagées |
| <input type="checkbox"/> | Covers restored and/or laminated /
Couverture restaurée et/ou pelliculée | <input type="checkbox"/> | Pages restored and/or laminated /
Pages restaurées et/ou pelliculées |
| <input type="checkbox"/> | Cover title missing /
Le titre de couverture manque | <input checked="" type="checkbox"/> | Pages discoloured, stained or foxed/
Pages décolorées, tachetées ou piquées |
| <input type="checkbox"/> | Coloured maps /
Cartes géographiques en couleur | <input type="checkbox"/> | Pages detached / Pages détachées |
| <input type="checkbox"/> | Coloured ink (i.e. other than blue or black) /
Encre de couleur (i.e. autre que bleue ou noire) | <input checked="" type="checkbox"/> | Showthrough / Transparence |
| <input type="checkbox"/> | Coloured plates and/or illustrations /
Planches et/ou illustrations en couleur | <input checked="" type="checkbox"/> | Quality of print varies /
Qualité inégale de l'impression |
| <input checked="" type="checkbox"/> | Bound with other material /
Relié avec d'autres documents | <input type="checkbox"/> | Includes supplementary materials /
Comprend du matériel supplémentaire |
| <input type="checkbox"/> | Only edition available /
Seule édition disponible | <input type="checkbox"/> | Blank leaves added during restorations may
appear within the text. Whenever possible, these
have been omitted from scanning / Il se peut que
certaines pages blanches ajoutées lors d'une
restauration apparaissent dans le texte, mais,
lorsque cela était possible, ces pages n'ont pas
été numérisées. |
| <input type="checkbox"/> | Tight binding may cause shadows or distortion
along interior margin / La reliure serrée peut
causer de l'ombre ou de la distorsion le long de la
marge intérieure. | | |
| <input checked="" type="checkbox"/> | Additional comments /
Commentaires supplémentaires: | | Continuous pagination. |

The Canadian Patent Office

RECORD

Vol. XXV.—No. 12.

DECEMBER 31st, 1897.

{ Price free by post in Canada and the
United States, \$2.00.
SINGLE NUMBERS, - - - 20 Cts

NOTICE.

All solicitors, agents or attorneys who, in circulars or advertisements, or otherwise, refer to the Commissioner or Deputy Commissioner of Patents, or to any other official of the Patent Office, for evidence of their professional standing, do so without authority.

INVENTIONS PATENTED.

NOTE.—Patents are granted for 18 years. The term of years for which the fee has been paid, is given after the date of the patent.

No. 58,227. Sewing Machine Feeding Mechanism. (Mécánisme d'alimentation pour machines à coudre.)

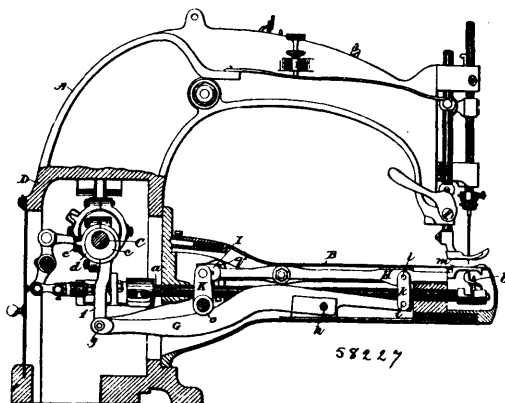

The Union Special Sewing Machine Co., Chicago, assignee of Lorenz Muther, Oak Park, Russell Green Woodward, Waukegan, and Elias C. Holland, Austin, all in Illinois, U.S.A., 1st December, 1897; 6 years. (Filed 27th October, 1897.)

Claim.—1st. A feeding mechanism comprising a vertically oscillating bar, a feed dog carrying bar with a link connection between the two, a rocking yoke, the end of said feed dog carrying bar having a sliding pivot connection between the arms of the yoke and an adjustable connection between the yoke and the feed dog carrying bar, substantially as described. 2nd. A feeding mechanism for sewing machines and the like, comprising the pivoted bar with means for oscillating it, the links pivoted thereto, the feed dog carrying bar pivoted to the opposite end of said links and having a slotted inner end, a rocking crank provided with a guiding pin fitting in the slot in the end of the feed dog carrying bar, and connections between the rocking crank and the feed dog carrying bar for giving the forward and backward movement thereto, substantially as described. 3rd. A feeding mechanism comprising a driving shaft, the pivoted bar and the rocking crank with connections between the two and said driving shaft, the feed dog carrying bar having pivotal connections at its forward end with the pivoted bar, and at the rear end with

the rocking crank, and an independent adjustable connection between the rocking crank and the feed dog carrying bar, substantially as described. 4th. In a feeding mechanism and in combination, the rocking yoke having vertical arms, the pivot pin between the two, the feed dog carrying bar having a sliding movement in the direction of its length on said pivot pin with a connection between the rocking yoke and the feed dog carrying bar for giving a forward and backward movement to the latter, and independent means for oscillating said feed dog carrying bar to give the upward and downward movements thereto, substantially as described. 5th. The herein described feeding mechanism for sewing machines and the like, comprising the pivoted bar G, the feed dog carrying bar, the link connection between the two at the forward end, the rocking yoke, the flat pin between the arms of said yoke, the feed dog carrying bar having a slotted head engaging said flat pin, and a separate adjustable connection between the rocking yoke and the feed dog carrying bar, substantially as described. 6th. In a feeding mechanism, the feed dog carrying bar, the rocking yoke having vertical arms, the end of said feed dog carrying bar having a sliding pivot connection with the vertical arms, one of said arms being provided with a curved slot, a bolt fitting therein, an arm P pivoted at one end on said bolt and at the other end to the feed dog carrying bar, and means for raising and lowering said feed dog carrying bar, substantially as described. 7th. In combination with the bed plate, the pivoted bar extending longitudinally thereof, with means for operating the same, the feed dog carrying bar arranged above the same and having pivotal connection with the forward end thereof, the rocking yoke pivotally secured to the rear end of said feed dog carrying bar, and an independent connection between the rocking yoke and the feed dog carrying bar for giving the forward and backward movement thereto, substantially as described. 8th. A sewing machine comprising a main shaft, a cylindrical casing extending in a direction at right angles to the main shaft, a pivoted bar extending lengthwise of and within the casing with connections between its rear end and the main shaft, a feed dog carrying bar also extending lengthwise of the casing and arranged in a plane above the plane of the pivoted bar, a rocking crank pivoted in said casing and connected to the feed dog carrying bar at the rear end thereof, said feed dog carrying bar having pivotal connection with the pivoted bar at its forward end, and connections between said rocking crank and the main shaft for reciprocating said feed dog carrying bar back and forth lengthwise of the casing, substantially as described.

No. 58,228. Pulverizing Apparatus. (Appareil pulvérisateur.)

William A. Kóneman and William Henry Hartley, both of 23 Moorfields, London, England, 1st December, 1897; 6 years. (Filed 2nd November, 1897.)

Claim.—1st. In a pulverizing or similar apparatus having conical grinding-rolls, the combination in a foundation frame of a central member A², radial arms A¹, and connections A³, substantially as described. 2nd. A pulverizing or similar apparatus in which standards carrying the grinding rolls are hinged to the main foundation frame. 3rd. In the framing of a pulverizing or similar apparatus having conical grinding rolls, a removable section such as C¹, substantially as and for the purpose described. 4th. In a pulverizing or similar apparatus, tangential strengthening ribs to support the grinding-surface of the grinding table, substantially as described. 5th. In a pulverizing or similar apparatus, the combination with a table such as F, of the ribs such as F², substantially as and for the purpose described. 6th. In a pulverizing or similar apparatus having conical grinding-rolls, the combination of a grinding table having a coned surface underneath and coned supporting rollers N, one disposed

below each grinding roll for the purpose described. 7th. In a pulverizing or similar apparatus, the combination with a grinding

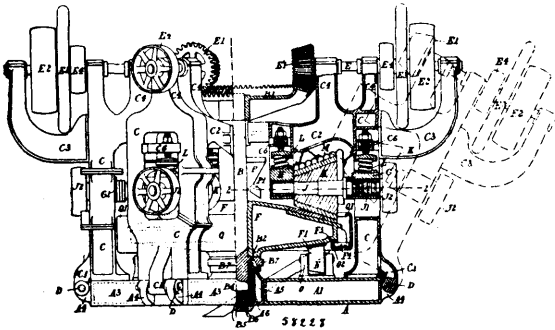
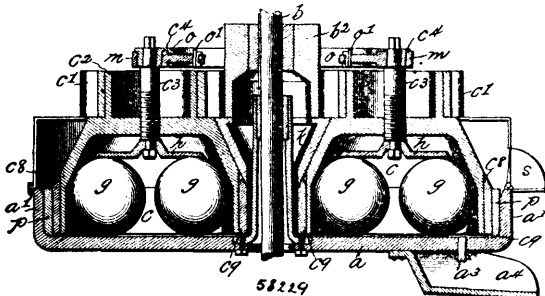

table having an overhanging circumferential lip F³ and an annular groove F⁵ in its underside, of a trough such as Q with a lip Q² extending up into the groove F⁵ from the trough, for the purpose described. 8th. In a pulverizing or similar apparatus having conical grinding-rolls, the combination with a central shaft B, of a hopper P encircling and fixed to the same, for the purpose described. 9th. In a pulverizing or similar apparatus, a housing or splasher placed above a grinding roll and having corrugations or baffle-projections presented towards the roll, substantially as and for the purpose described. 10th. In a pulverizing or similar apparatus, movable guide blades R arranged spirally over the table, substantially as and for the purpose described. 11th. In a pulverizing or similar apparatus having conical grinding-rolls, the combination with guide blades of mechanism for reciprocating them above the table, for the purpose described. 12th. In a pulverizing or similar apparatus, the combination with a conical table F of guide blades so slung or otherwise supported as to be movable in a direction approximately parallel with the grinding surface, for the purpose described. 13th. In a pulverizing or similar apparatus, the combination with guide blades such as R, of an eccentric B⁷ or cam in operative connection with the shaft B, for the purpose described. 14th. In a pulverizing or similar apparatus, the combination with a foot-step bearing of circulation, lubricating apparatus such as U, U¹, U², for the purpose specified. 15th. In a pulverizing or similar apparatus, the combination with the shaft B and foot-step bearing, of a lip B⁸, for the purpose described.

No. 58,229. Ore Crusher. (Machine à broyer le minerai, etc.)



Jacob C. Wiswell, West Medford, Henry B. Wells, Boston, and Henry G. Dillaway, Quincy, all in Massachusetts, U.S.A., 1st December, 1897; 6 years. (Filed 22nd April, 1896.)

Claim.—1st. In an ore crushing and pulverizing machine, a pan, balls resting upon the pan, hollow inverted rolls supported upon the balls, and means for rotating the rolls on their own axes, and also causing the n to travel about the pan in a circular path simultaneously, as described. 2nd. In a machine of the character described, a pan, balls resting upon the pan, hollow inverted rolls supported upon the balls, a wedge cone bearing upon the upper surfaces of the rolls, and means for rotating the balls and rolls, as and for the purposes set forth. 3rd. In a machine of the character described, a pan, balls resting upon the pan, hollow inverted rolls supported by the balls, and means for revolving the balls within the rolls, rotating the balls on their own axes and causing the rolls and balls to travel about the pan all simultaneously, as set forth. 4th. In combination, pan a, balls g resting thereon, discs h resting on the balls, spindles c³ carrying disc h, rolls c carried by spindles c³, gears c¹ b² driving rolls c, wedge cone k bearing upon rolls c and supporting gear b², ring o, and elastic connections between the ring and spindles c³, all as and for the purposes set forth.

No. 58,230. Nut-Lock. (Arrêtée-écrou.)

John W. KaVear, Charles E. Gibbs and Ernestine Simms, all of Decatur, Georgia, U.S.A., 1st December, 1897; 6 years. (Filed 6th September, 1897.)

Claim.—1st. In a nut-lock, the combination with a bolt, of a nut thereon having a rectangular shoulder or extension thereon, and a

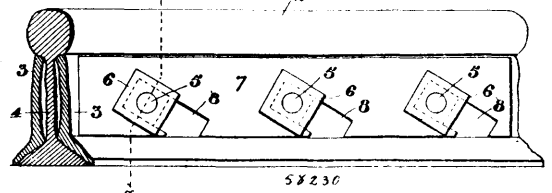

locking plate having a diagonally arranged slot therein adapted to be passed around the rectangular extension on said nut. 2nd. In a nut-lock, the combination with a bolt, of a nut thereon having a rectangular shoulder or extension upon one side thereof, and a locking plate having a diagonally arranged slot therein with parallel sides and an open lower end adapted to be passed around the extension on said nut, substantially as and for the purpose described. 3rd. The combination with a rail and a fish-plate, of a plurality of bolts for securing the fish-plate to said rail, nuts upon said bolts having rectangular shoulders or extensions upon their inner surfaces and a locking plate having a series of diagonally arranged slots therein, having parallel sides and open at their lower ends, the said plate adapted to be inserted between the inner surface of the main part of said nut and the outer surface of said fish-plate, with the slots therein embracing the rectangular extensions on said nuts, and the upper edges of said plate engaging the under side of the head of the rail, substantially as and for the purpose described. 4th. The combination with a rail and a fish-plate, of a plurality of bolts for securing the fish-plate to said rail, nuts upon said bolts having rectangular shoulders or extensions upon their inner surfaces, and a locking plate having a series of diagonally arranged slots therein, having parallel sides and open at their lower ends, the said plate adapted to be inserted between the inner surface of the main part of said nut and the outer surface of said fish-plate, with the slots therein embracing the rectangular extensions on said nuts, and the upper edges of said plate engaging the under side of the head of the rail, the said extensions being thicker than said locking plate, substantially as and for the purpose described.

No. 58,231. Electric Railway.

(Chemin de fer électrique.)

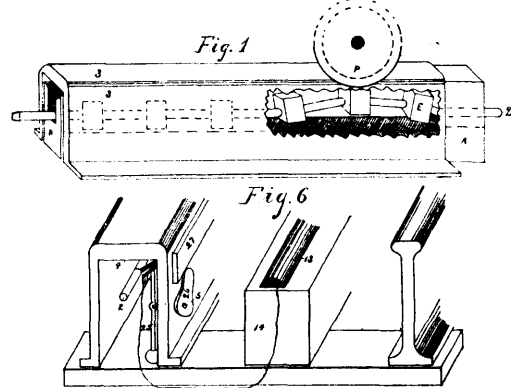

Addison Norman, William McCabe, Willis Jones and William B. Taylor, all of Toronto, Ontario, Canada, 1st December, 1897; 6 years. (Filed 6th November, 1896.)

Claim.—1st. In an electric railway, the combination of a supporting rail, upon which the cars run, the rail being formed in sections, which are insulated from each other, and with a central cavity, a main conductor mounted within the cavity of the said rail, insulating supports for the conductor, also arranged within the cavity, and means for bringing the main conductor and the sections of the rail into electric engagement successively, substantially as set forth. 2nd. In an electric railway, the combination of a supporting rail upon which the cars run, the rail being formed in sections, which are insulated from each other, and with a central cavity, one end of each section being reduced in size and extended beyond the bearing face of the car wheel, whereby the said sections telescope one into the other, a main conductor mounted within the cavity of the rail, insulating supports for the conductor, and means for bringing the conductor and rail sections successively into electric connection, substantially as set forth. 3rd. In an electric railway, the combination of a supporting rail upon which the cars run, the rail being formed of sections of substantially inverted U-shape in cross section, a main conductor mounted within the cavity formed within the rail, insulating supports for the conductor also mounted in the said cavity, and means for bringing the conductor and the rail sections successively into electric connection, substantially as set forth. 4th. In an electric railway, the combination of a main con-

ductor, a closed conduit therefor, formed of sections, which are insulated from each other, the insulating supports for the conductor within the conduit, and a series of iron blocks secured to the conductor within the cavity, and normally out of contact with the rail, but capable of being attracted by a magnet and brought into contact with the rail, said blocks being in one or more pieces, substantially as set forth. 5th. In an electric railway, the combination of a main conductor, a closed conduit therefor, formed of sections, which are insulated from each other, the insulating supports for the conductor within the conduit, and a series of pendulum-like connecting pieces hung upon the conductor, and free to vibrate thereon, to make contact with the sides of the conduit, when attracted by a magnet, substantially as set forth. 6th. In an electric railway, the combination of a supporting rail, upon which the cars run, the rail being formed of sections, of substantially inverted U-shape in cross-section, whereby there is formed a cavity within the rail, a main conductor mounted in the cavity of the said rail, insulating supports therefor, and a series of pendulum-like connecting pieces, hung upon the conductor and free to vibrate thereon, to make connection with the side of the rail, when attracted by a magnet, substantially as set forth. 7th. In an electric railway, the combination of a supporting rail, upon which the cars run, the rail being formed of sections of substantially inverted U-shape in cross-sections, a main conductor mounted within the cavity formed within the rail, and insulating supports for the conductor, also mounted in the said cavity, substantially as set forth. 8th. In an electric railway, comprising a supporting rail for the cars, having a cavity constituting a closed conduit, an insulated electric supply conductor mounted therein, a contact-making and breaking device arranged within such a conduit, means arranged adjacent to the track for operating such device for making contact, and means for automatically restoring the device to normal position, with the contact broken, substantially as set forth. 9th. In an electric railway system, comprising a closed conduit formed by one of the supporting rails for the cars, a supply conductor mounted therein, but insulated therefrom, contact-making and breaking devices arranged within the said conduit, a sectional conductor, connections between the sections of said conductor and the said contact devices, operating devices for each contact device arranged adjacent to the tread-parts of the rail, and means for automatically restoring the contact devices to their normal positions with the contacts broken, substantially as set forth. 10th. In an electric railway system, comprising a closed conduit, a main supply conductor, contact devices within the conduit, mechanical connections, also within the conduit, between adjacent contact devices, and means whereby the contact devices are operated by the passing of the cars, substantially as set forth. 11th. In an electric railway system, comprising a closed conduit, a supply conductor mounted therein, an exposed sectional conductor, contact devices for electrically uniting the main and the sectional conductors, arranged within the said conduit, mechanical connections, also within the conduit, between adjacent contact devices, means whereby the contact devices are operated by the passing cars, and means for automatically restoring said operating means to normal position, substantially as set forth. 12th. In an electric railway system, comprising a main supply conductor, a sectional conductor, contact devices for electrically connecting the two conductors, means which tend to move the contact device to break the electric connection, a locking device which holds it when connection is made, means for operating the contact device to make connection, and a connection between the locking device and an adjacent contact device, whereby when the latter is operated the lock is released, allowing the contact device, which it holds, to be restored to normal position, substantially as set forth. 13th. In an electric railway system, comprising a main supply conductor, a sectional conductor, a contact-making and breaking device, a bolt or catch, which holds the contact device in position to make electric contact, means for operating the contact device by the passing of a car, means which tend automatically to restore the contact device to its normal position, and a connection between the said bolt or catch and a contact operating device in advance, substantially as set forth. 14th. In an electric railway system, comprising a rail conductor 3, a supply conductor 2 therein, an exposed sectional conductor, a contact-making and breaking device within the conduit, a bolt or catch within the conduit for holding the contact device, means for automatically restoring the device to position to break contact, an operating device extending outside of the conduit whereby a passing car operates it, and a mechanical connection arranged within the conduit, between the said bolt or catch, and a contact operating device in advance, substantially as set forth. 15th. In an electric railway system, a contact or working conductor arranged between two tracks and provided with two contact surfaces, whereby trolleys or collectors, carried by trains moving in opposite directions, may take electricity from the same conductor, substantially as set forth. 16th. In an electric railway system, a contact or working conductor, having two parallel separated contact surfaces 13', substantially as set forth.

No. 58,232. Hydraulic Gold Separator.

(Appareil hydraulique à separer l'or.)

John H. Barr and James F. Johnson, Kansas City, and William E. Harvey, Rosedale, all in Kansas, U.S.A., 1st December, 1897; 6 years. (Filed 5th July, 1897.)

Claim.—1st. In a gold-separating apparatus, a jar comprising a body-portion having a discharge-opening near its upper end and an

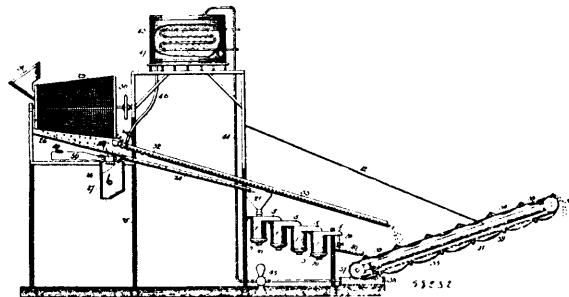

inlet-opening, a removable bottom supporting one or more amalgam-plates which project up into the body of the jar, and an inlet-pipe extending through said inlet-opening and surrounded by said amalgam plates, substantially as described. 2nd. In a gold-separating apparatus, a jar comprising a body-portion having an inlet-opening and a discharge-opening near its upper end, a removable hollow or segmental bottom for said jar, containing mercury, amalgam-plates carried thereby and projecting up into the body of the jar, and an inlet-pipe extending through the inlet-opening and having its end arranged to discharge into the mercury in said hollow bottom, substantially as described. 3rd. In a gold-separating apparatus, a jar consisting of a body-portion having an inlet opening and a discharge-opening, a removable hollow bottom adapted to contain mercury and provided internally with ribs, amalgam-plates supported upon said ribs and projecting upwardly into the body-portion of the jar, and an inlet-pipe for said jar, having its lower end surrounded by said amalgam-plates and adapted to discharge the gold-bearing material into the mass of mercury in the removable bottom, substantially as described. 4th. In a gold-separating apparatus, the combination with a series of jars arranged in different horizontal planes and each provided with a tubular extension at its upper end, having a discharge-opening, which extension overlaps the body-portion of the jar next in advance, and provided with removable bottoms, and at their upper ends with inlet-openings which register with the discharge-openings of said extensions, and with inlet-pipes which communicate with said registering openings and discharge the gold-bearing material into the mass of mercury which is contained in said removable bottoms, a discharge-pipe communicating with the discharge-opening of the extension of the foremost or lowest of said jars, and means for supplying the gold-bearing material to the inlet-pipe of the rearmost or highest jar, and of regulating the head-pressure of said material, substantially as described. 5th. In a hydraulic gold-separating apparatus, the combination of a series of jars, each provided with a tubular extension at its upper end, which communicates with the body of the preceding jar, and containing mercury, a chute communicating with the first jar of the series, a magnetic plate overhanging the same at its upper end, and provided with a magnetic extension inclining in the opposite direction, and a hopper below said extension, into which the magnetic particles are discharged, substantially as described. 6th. In a hydraulic gold-separating apparatus, the combination of a series of jars, each provided with a tubular extension at its upper end, which communicates with the body of the preceding jar, and containing mercury, a chute communicating with the first jar of the series, a magnetic plate overhanging the same at its upper end, and provided with a magnetic extension inclining in the opposite direction, a hopper below said extension, into which the magnetic particles are discharged, a rotating screen above said magnetized plate, an inclined screen between its discharge end and the magnetic plate, and said chute, a conveyor below the same and below the discharge of the series of jars, a reservoir, and a valve-controlled discharge-pipe connected therewith and arranged to discharge upon said inclined screen, substantially as described. 7th. In a gold-separating apparatus, a jar comprising a body-portion, having a discharge-opening near its upper end, and an inlet-opening, a removable bottom supporting one or more amalgam-plates, which project up into the body of the jar, an inlet-pipe extending through said inlet-opening and surrounded by said amalgam-plates, and a notched or apertured plate partitioning the removable bottom, substantially as described. 8th. In a hydraulic gold-separating apparatus, the combination of a series of jars, each provided with a tubular extension at its upper end, which communicates with the body of the preceding jar, and containing mercury, a chute communicating with the first jar of the series, a magnetic plate overhanging the same at its upper end, and provided with a magnetic extension inclining in the opposite direction, a hopper below said extension, into which the magnetic particles are discharged, a rotating screen above said magnetized plate, an inclined screen between its discharge end and the magnetic plate and said chute, a second inclined chute, a conveyor below the same and below the discharge of the series of jars, a reservoir, a valve-controlled discharge-pipe connected therewith and arranged to discharge upon said inclined screen, a tank at the lower end of the conveyor, a trough within the conveyor and arranged to discharge into said

tank, a pipe connecting said tank and the reservoir, and a pumping-apparatus to force the water from said tank into said reservoir, substantially as described.

No. 58,233. Rail Fastener. (Attache de rails.)

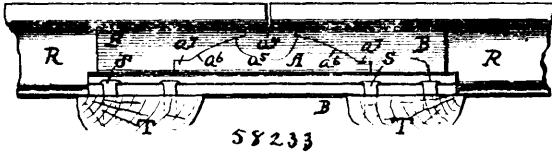

Jacob E. Smith, Homestead, Pennsylvania, U.S.A., 1st December, 1897; 6 years. (Filed 2nd April, 1897.)

Claim.—1st. In a railway rail joint, the combination of a key-piece consisting of two sides, each extending along the web of the two rails, and fitting close against the web head and foot, and having its lower edge rebated, and provided near the ends with pins engaging perforations in the feet of the rails, and its upper edge shortened by a shoulder and sloped off convexly, and said sides connected by a central rigid connection of angular longitudinal section adapted to pass through a corresponding perforation in the rail web, and a pair of fish-plates fitting the rails close and each extending in cross-section from the underside of the head around the edge of the foot, and having a central recess or perforation which is the exact counterpart of the side of the key-piece and making close butt joints therewith, and the ends of the rail webs notched to form an angular perforation when the two rail ends are brought together to receive the transverse connection of the key-piece, substantially as set forth. 2nd. In a railway rail joint, the combination with the web of the rail ends of notches forming when the two rail ends are brought together an angular perforation, and a key-piece consisting of two sides rigidly connected transversely by a central part fitting the perforation in the rail web ends and fitting close against the webs and the underside of the heads and the upper faces of the feet of the rails and having on its lower edges at each end a pin engaging the corresponding perforation in the feet of the rails, substantially as set forth. 3rd. In a key-piece for a railway rail joint, the combination of two sides each fitting against the web and the underside of the head and the foot of the rail, a transverse centre of angular section rigidly connecting said sides, a rebate at the lower edge of each side, a central segmental recess in the lower edge of each side, and an upper edge shortened by offsets and convexly sloping ends, substantially as set forth. 4th. In a fish-plate for a railway rail joint, the combination of a plate extending from the underside of the head of the rail down the web and over and around the edge of the foot and fitting close upon the same, and a central recess the exact counterpart of the side of a key-piece which it is adapted to receive, substantially as set forth. 5th. In a railway rail joint, the combination of a pair of rail ends having the ends of their webs notched to form when brought together an angular perforation, a key-piece A, having two sides transversely connected by a centre adapted to pass through the perforation in the web of the rails and having in its lower edges pins engaging the rails, and the upper edges of the sides shortened by offsets, a pair of fish-plates B, each having a recess which is the exact counterpart of the side of the key-piece adapted to pass over and receive and interlock with the same, and spikes S driven close against the edges of the fish-plates, substantially as set forth.

No. 58,234. Apparatus for Preparing Acetylene Oil.

(Appareil pour préparer l'huile acétyline.)

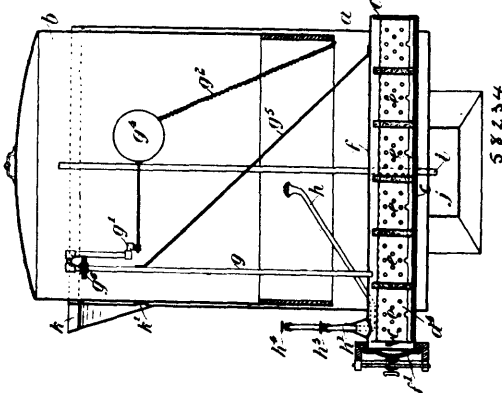

Frederick S. Thorn and Charles Huddle, both of London, England, 1st December, 1897; 6 years. (Filed 15th June, 1897.)

Claim.—1st. In apparatus for generating, storing and cooling acetylene gas, wherein a gas-holder or gasometer is used, the employment of one or more hermetically closed holders, each located in the

gas-holder and preferably surrounded by the water contained therein, and designed to contain a calcium carbide container divided into a series of compartments of predetermined size by partitions, and each of the said holders having two outlets into the interior of the gas-holder, one of which is controlled by a cock or valve, substantially as described. 2nd. In apparatus for generating acetylene gas wherein a gas-holder and one or more calcium carbide containers each having two outlets into the gas-holders are employed, controlling the generation of the gas by means of a valve operated by the movement of the sliding cylinder of the gas-holder, which valve is fitted to the outlet of the generated gas into the gas-holder, so that the up and down movement of the sliding cylinder controls the flow of gas into the gas-holder from one outlet, and the flow of water into the containers through the other outlet, substantially as herebefore described. 3rd. The combination with apparatus of the kind described, of a cooling chamber arranged at the bottom of the gas-holder, and of a pipe passing from the top of the gas-holder into the cooling chamber through the water contained in the gas-holder, substantially as described. 4th. In apparatus of the kind described in claim 1, forming the partitions, which divide the calcium carbide containers into compartments, with openings or notches at their upper ends and with gauze or perforated metal funnels or tubes and providing the compartments with channels or passages formed by perforated plates placed longitudinally between the partitions on either side or on both sides of the containers, substantially as described. 5th. The combination and arrangement of parts forming the improved apparatus for generating, storing and cooling acetylene gas herebefore described and illustrated in the accompanying drawings.

No. 58,235. Nail, Spike, Bolt, Screw, etc.

(Clou, cheville, bouton, vis, etc.)

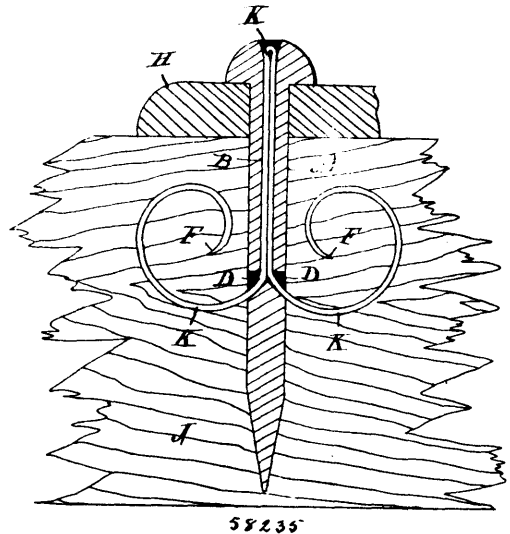

Christopher J. Lancaster, Deptford, England, 1st December, 1897; 6 years. (Filed 30th August, 1897.)

Claim.—1st. A spike, screw, bolt or nail having a hole, channel, or groove B, through a portion of its length, terminating in two opposite holes D, D, leading outwardly, or one only, in combination with a staple, cotter, split or other pin K, of greater length than the channel B, having its feet or extremities bevelled, the said staple, cotter or pin forced through the channel after the spike or the like has been driven home, so that the legs project beyond the spike or the like and penetrate the timber or other material, substantially as and for the purpose described.

No. 58,236. Game. (Jeu.)

Hugh B. Cowper, Montreal, Quebec, Canada, 1st December, 1897; 6 years. (Filed 16th November, 1897.)

Claim.—1st. A game comprising a board with pockets, a ball or balls, and movable guard for such pockets, as shown and described. 2nd. A game comprising a board with pockets, a ball or balls, a chute or chutes, pin holes to receive guards in front of said pockets and movable guard pins for such pockets, as shown and described. 3rd. A game comprising a board with pockets, a ball or balls, a chute or chutes, pin holes to receive guards in front of said pockets and movable guard pins for such pockets, the pin holes numbering in excess of the guard pins employed, as shown and described. 4th. A game comprising a board with a central and outer pockets and a

guard wall *k*, with openings about the central pocket, a ball or balls, a chute or chutes, pin holes to receive guards in front of said

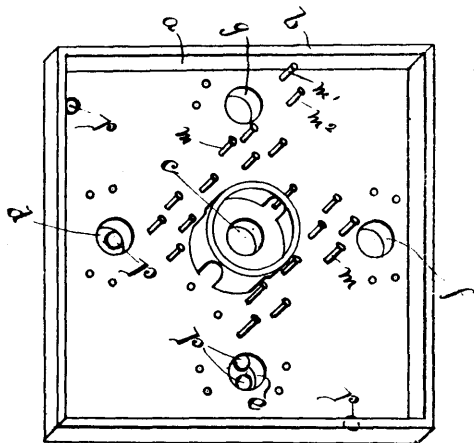

57236

pockets and movable guard pins for such pockets, as shown and described and for the purpose set forth.

No. 58,237. Apparatus for and Process of Treating Garbage. (*Appareil et procédé pour le traitement des trippailles.*)

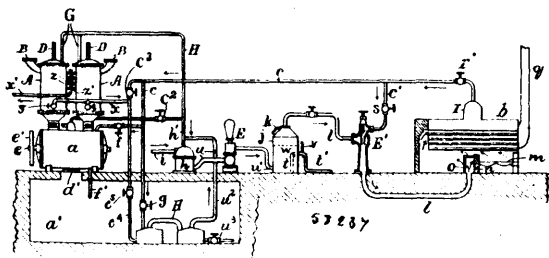

57237

Cyrus C. Currier, Summit, New Jersey, assignee of Emil Holthaus, Canarsie, New York, U.S.A., 1st December, 1897; 6 years. (Filed 21st October, 1896.)

Claim.—1st. The herein described method for treating refuse, which consists, first, in cooking the garbage in a rendering tank and drawing off the vapours and condensing the same during the cooking operation; second, drawing the grease and water from the rendering tank upon the completion; of the cooking; third, discharging the material from the rendering tank into a drying cylinder and confining the material therein; fourth, stirring and heating the material in the cylinder and drawing off the vapour and gases generated during the drying operation, condensing the vapour and washing the gases with water; fifth, separating the water from the unabsorbed gases and discharging the gases into a furnace for consumption, as and for the purpose set forth. 2nd. The method herein described for treating refuse, which consists, first, in cooking the garbage in a rendering tank and drawing off the vapours and condensing the same during the cooking operation; second, drawing the grease and water from the rendering tank upon the completion of the cooking; third, separating the grease from the water and concentrating the water by evaporation; fourth, discharging the material from the rendering tank into a drying cylinder and confining the material therein; fifth, stirring and heating the material in the cylinder and drawing off the vapour and gases generated during the drying operation, condensing the vapour and washing the gases with water, and sixth, separating the water from the unabsorbed gases and discharging the gases into a furnace for consumption, as and for the purpose set forth. 3rd. An odourless apparatus for treating refuse, consisting of a tight rendering tank, a steam boiler with suitable connections to the tank for heating the same by the steam, a jet condenser arranged and operated to condense the vapours from such tank, a vacuum pump for drawing the water and uncondensed gases from the condenser, means for separating the water from the gases when discharged from the vacuum pump, a furnace arranged to heat the steam boiler with a pipe receiving the gases from the separator, and an ejector inserted in such pipe to force the gases into the furnace for consumption, as and for the purpose set forth. 4th. An odourless apparatus for treating refuse, consisting of a drying cylinder with means for heating the same and stirring the material, a tight rendering tank connected with the top of the cylinder and provided with means for heating the tank, a jet condenser arranged and operated to condense the

vapours from such tank and cylinder, a vacuum pump for drawing the water and uncondensed gases from the condenser, means for separating the water from the gases when discharged from the vacuum pump, and a furnace with pipe receiving the gases, and an ejector inserted in such pipe to force the gases into the furnace for consumption, as and for the purpose set forth. 5th. An odourless apparatus for treating refuse, comprising a drying cylinder with means for heating the same and stirring the material, a series of separate rendering tanks arranged above the same, and gates and pipes for tightly connecting the tanks in succession with said cylinder, suitable inlets for separately charging the rendering tanks and means for tightly closing the same, means for heating each tank and drawing off the fluid from the interior of the same, a condenser and suitable pipe connections for drawing off and condensing the fumes from the rendering tanks and drying cylinder, a vacuum pump for drawing the water and uncondensed gases from the condenser, means for separating the water from the gases when discharged from the vacuum pump, and a furnace with pipe receiving the gases, and an ejector inserted in such pipe to force the gases into the furnace for consumption, as and for the purpose set forth. 6th. An odourless apparatus for treating refuse, consisting of a drying cylinder with means for heating the same and stirring the material, a series of separate rendering tanks arranged above the same, and gates and pipes for tightly connecting the tanks in succession with said cylinder, heating each tank and drawing off the grease, means for discharging the fluid from each tank upon the completion of the cooking, and an evaporator for concentrating such fluid, a condenser and pipes for condensing the vapours from the tanks and cylinder, a vacuum pump for drawing the water and uncondensed gases from the condenser, means for separating the water from the gases when discharged from the vacuum pump, and a furnace with pipe receiving the gases, and an ejector inserted in such pipe to force the gases into the furnace for consumption, as and for the purpose set forth.

No. 58,238. Electric Alarm. (*Avertisseur électrique.*)

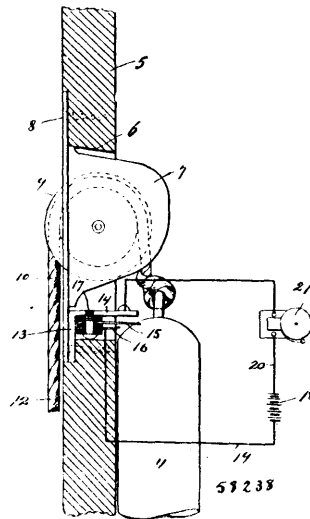

57238

Paul V. Vandeveld, Corona, New York, U.S.A., 1st December, 1897; 6 years. (Filed 7th August, 1897.)

Claim.—1st. A window frame provided with means for supporting a window sash, consisting of a counterbalance weight, a cable connected therewith, and an electrical alarm device which is placed in a circuit which is open when the weight is in its highest position, and closed when said weight is lowered, substantially as shown and described. 2nd. In a device of the character herein described, a plate or board which forms a part of the window frame, a casing mounted therein, a pulley mounted in said casing and provided with a cable to one end of which a counterbalance weight is attached, a stationary plate mounted in said opening and provided with an outwardly directed arm, a spring arm in electrical connection with said first named arm, and another arm which is insulated from all of said parts, and electrical alarm devices in a circuit which is in electrical connection with the first named arm and also with the last named arm, said circuit being open when the counterbalance weight is in its highest position, and closed when said counterbalance weight is lowered, substantially as shown and described.

No. 58,239. Manufacture of Mosaic Floor Cloth. (*Fabrication de toile en mosaïque.*)

Frederick Walton, 114 Holborn, London, England, 1st December, 1897; 6 years. (Filed 10th February, 1897.)

Claim.—1st. The manufacture of mosaic floor cloth by cutting tesserae from sheets of variously coloured floor cloth material, laying these in marked out spaces in the periphery of a composing cylinder, transferring them to backing fabric on a pinned drum, and then by

pressing apparatus causing the tesserae to cohere and adhere to this backing, substantially as described. 2nd. The construction of the

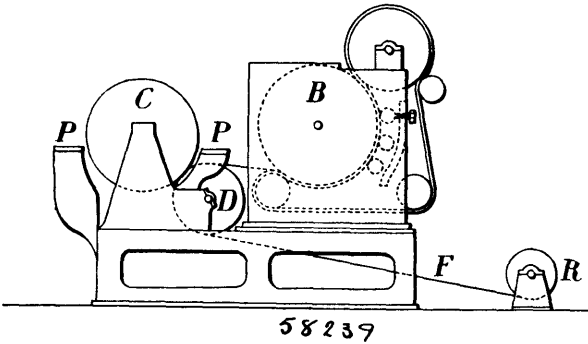

composing cylinder with numerous holes to receive plugs variously slotted to hold the blades that separate or mark out the spaces of the pattern, substantially as described. 3rd. The modified method of manufacture of mosaic floor cloth by arranging the tesserae in composing plates which being passed tangentially in contact with the backing fabric the pinned drum have tesserae transferred to the backing on which they are fixed by pressing apparatus, substantially as described. 4th. For operating as set forth, the use of stencil and pressing plates to determine the positions of the tesserae on the composing plate, substantially as described. 5th. The modified method of manufacture by placing the tesserae directly on the backing fabric on which their positions are indicated, as by being marked in colours or by the image of a magic lantern slide, substantially as described.

No. 58,240. Gas Generating Apparatus.
(Appareil à générer le gaz.)

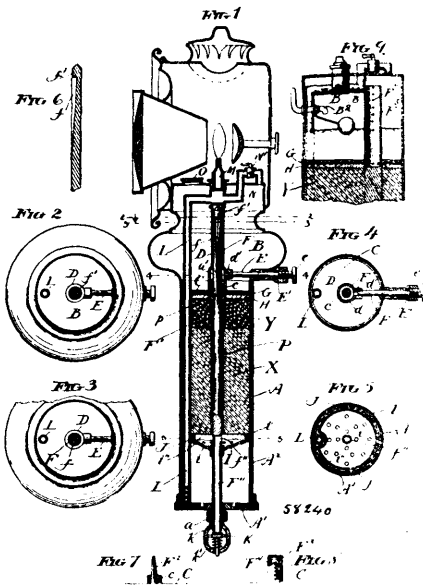

John Schumacher, Chicago, Illinois, U.S.A., 1st December, 1897; 6 years. (Filed 5th February, 1897.)

Claim.—1st. In an apparatus for generating gas from a metallic carbide and water and for arresting the generation when desired, the combination of a generating chamber adapted to contain the carbide and having an inlet for water, means for introducing into said chamber, through said inlet, during the period of generation, a regulated quantity of water, means for confining the residue where it forms, between the water inlet and the body of carbide, whereby it is made to serve as a medium through which the water is fed to the carbide and whereby, in order to arrest the generation of gas, the dry carbide may be allowed to fall away from the residue and leave the latter undisturbed where it is formed, and means for keeping the water and carbide apart when the carbide and residue are thus separated, substantially as set forth. 2nd. In an apparatus for generating gas from a metallic carbide and water and maintaining the quantity generated practically constant throughout the entire period of generation, the combination with a chamber adapted to contain the carbide and having a water inlet, of means for confining the residue where it forms, between the water inlet and the body of carbide, whereby it is made to serve as a medium through which the water is fed to the carbide, means for continuously supply-

ing the residue, throughout the period of generation, with a limited quantity of water, and means for gradually and continuously increasing, throughout the entire period of generation, the quantity of water supplied to the residue, whereby the quantity of gas generated and consequently its pressure within the generating chamber, are kept practically constant throughout the entire period of generation, substantially as described. 3rd. In an apparatus for generating gas from a metallic carbide and water, the combination with a chamber adapted to contain carbide and having a water inlet at top, a pervious body crossing the chamber from side to side below the water inlet, means for holding the carbide in contact with said pervious body, means for introducing a regulated quantity of water on top of said pervious body, means for confining the residue where it forms between the pervious body, and the body of carbide, whereby it is made to serve as a medium through which the water is fed to the carbide, and means for gradually increasing, throughout the period of generation, the quantity of water supplied to the residue, substantially as set forth. 4th. In an apparatus for generating gas from a metallic carbide and water, the combination with a chamber adapted to contain the carbide and residue and having a water inlet, of means for supplying the chamber with a regulated quantity of water, means for confining the residue where it forms opposite the water inlet whereby it is made to serve as a medium through which the water is fed to the carbide, and means operated by force resulting from the expansion of the material during the reaction for gradually increasing, throughout the period of generation, the quantity of water supplied to the residue, substantially as set forth. 5th. In an apparatus for generating gas from a metallic carbide and water, the combination with a chamber adapted to contain the carbide and residue and having a water inlet, of a movable part adapted to be moved by force resulting from the expansion of the material during the reaction, and means operatively connected with said movable part for controlling the admission of water, substantially as set forth. 6th. In an apparatus for generating gas from a metallic carbide and water, the combination with a chamber adapted to contain the carbide and residue and having a water inlet, of a movable part adapted to be moved by force derived from the expansion of the material during the reaction, and a device operatively connected with said movable part for controlling the admission of water, said device having means whereby, as it is moved, a gradually increasing quantity of water is admitted, substantially as set forth. 7th. In an apparatus for generating gas from a metallic carbide and water, the combination with a chamber adapted to contain the carbide and residue and having a water inlet, of a movable part arranged in contact with the solid material and adapted to be moved thereby, and a valve, operatively connected with said movable part, for controlling the admission of water, substantially as set forth. 8th. In an apparatus for generating gas from a metallic carbide and water, the combination with a chamber adapted to contain the carbide and residue and having a water inlet, of a movable part arranged in contact with the solid material and adapted to be moved thereby, and a valve, operatively connected with said movable part for controlling the admission of water, said valve having means of increasing the quantity of water admitted to the chamber, as it is moved, substantially as set forth. 9th. In an apparatus for generating gas from a metallic carbide and water, the combination of a chamber adapted to contain the carbide and residue and having a water inlet, a movable part arranged in contact with the solid material and adapted to be moved thereby, and a sliding valve operatively connected with the follower and fitting in the water inlet, said valve having a graduated passage, substantially as set forth. 10th. In an apparatus for generating gas from metallic carbide and water, the combination of means for confining the carbide and residue on all sides and holding them together in the form of a body of regular shape, said means being extensible so as to permit the body to expand, and means for supplying the carbide with water, substantially as set forth. 11th. In an apparatus for generating gas from metallic carbide and water, the combination with a chamber adapted to contain the carbide and residue and having a water inlet at top, of means for holding the body of carbide in contact with the underside of the body of residue with a yielding force, whereby the body of carbide may be displaced downward by the force resulting from the expansion of the material during the reaction, substantially as set forth. 12th. In an apparatus for generating gas from metallic carbide, the combination of a chamber adapted to contain the carbide and residue and having a water inlet at top, means for normally supporting the carbide and holding it in contact with the underside of the body of residue, and means for removing the carbide from contact with the body of residue, substantially as set forth. 13th. In an apparatus for generating gas from a metallic carbide and water, the combination of a chamber adapted to contain the carbide and residue and having a water inlet at top, a movable follower upon which the body of carbide rests, means for holding the follower, with a yielding force, in position to support the body of carbide, and means for lowering the follower at will and thereby permitting the body of carbide to fall away from the body of residue, leaving the latter confined where it formed, substantially as set forth. 14th. In an apparatus for generating gas from a metallic carbide and water, the combination of a chamber adapted to contain the carbide and residue and having a water inlet at top, a follower having frictional contact with the sides of the chamber, for supporting the body of carbide, and means for lowering the follower at will, sub-

stantially as set forth. 15th. In an apparatus for generating gas from a metallic carbide and water, the combination of a chamber adapted to contain the carbide and residue and having a water inlet at top, a movable follower by which the body of carbide is supported, means for holding said follower, with a yielding force in position to support the body of carbide, and a stem connected with the follower and projecting from the chamber for moving it at will, substantially as set forth. 16th. In an apparatus for generating gas from a metallic carbide and water, the combination of an inclosure adapted to be filled with carbide and to confine the residue where it forms in contact with the carbide, whereby when the apparatus is jarred or upset the carbide and residue are prevented from intermixing, said inclosure being extensible in order to allow for the increase in the bulk of the material which takes place during the reaction, and means for supplying the carbide with water, substantially as set forth. 17th. In apparatus for generating gas from a metallic carbide and water, the combination of a chamber adapted to contain the carbide and residue and having a water inlet at top, a follower located below the body of carbide, means for holding the follower with a yielding force in position to support the body of carbide, and means operatively connected with the follower for controlling the admission of water to the chamber, substantially as set forth. 18th. In an apparatus for generating gas from a metallic carbide and water, the combination of a chamber adapted to contain the carbide and residue and having a water inlet at top, a follower located below the body of carbide, means for holding the follower with a yielding force in position to support the body of carbide, a device for controlling the admission of water, and a stem connecting said device and follower and projecting from the chamber in position to be engaged, substantially as set forth. 19th. In an apparatus for generating gas from a metallic carbide and water, the combination of a chamber adapted to contain the carbide, and having a water inlet at top, a follower located below the body of carbide, means for holding the follower with a yielding force in position to support the body of carbide, a hollow stem connected to the follower and projecting from the chamber in position to be reached and moved, the interior of said stem being in communication with the chamber and with the atmosphere, and a safety valve for controlling the passage in the stem, substantially as set forth.

No. 58,241. Process of Extracting Fats and Meat Juices. (*Procédé pour extraire la graisse et jus de la viande.*)

Brainard Clark and Sydney F. H. Thoresby, both of Alexandria, and William B. Sharp, Newcastle, all in New South Wales, Australia, 1st December, 1897; 6 years. (Filed 25th January, 1897.)

Claim.—1st. In a process for the extraction of fats and meat juices or essence from animal carcasses, disintegrating and mincing the carcass, scalding the disintegrated bony parts with water at a degree of heat sufficient to free or affect the gluten, and glutinous and alkaline constituents, expressing the juices from the fleshy parts in the presence of heat, mixing the expressed flesh juices with liquor from the scalding of the bony parts, and removing the fat, substantially as described. 2nd. In a process for the purposes set forth, mincing and disintegrating the fleshy parts and bony parts of the animal carcass, separately, expressing the juices from the fleshy parts, scalding the disintegrated bony parts at a degree of heat insufficient to free or affect the glutinous and alkaline constituents, mixing the expressed flesh juices with liquor from the scalding of the bony parts, removing the fat, and evaporating to convert the residual juices into meat extract, substantially as described. 3rd. In a process for the purpose set forth, disintegrating and mincing the animal carcass, separately treating the fleshy parts and bony parts to extract their juices and essences at a degree of heat insufficient to free or affect glutinous and alkaline constituents, and mixing the extracted essences from the bony parts with the juices from the fleshy parts, substantially as described. 4th. In a process for the purpose set forth, the treatment of disintegrated bony parts of the animal carcass by scalding them at a heat insufficient to free the glutinous and alkaline constituents, mixing the liquor from the scalded bones with juices from the fleshy parts of the carcass, removing the fats, and evaporating the residual meat juices or essence to the desired state, substantially as described. 5th. The complete process for the extraction of fats and meat juices or essence from animal carcasses as herein set forth in detail, substantially as described and explained.

No. 58,242. Shuttle Check for Power Looms. (*Arrêt de navette pour méliers.*)

David W. Shirreffs, Carleton Place, Ontario, Canada, 2nd December, 1897; 6 years. (Filed 13th September, 1897.)

Claim.—1st. In a shuttle check, the frame of the contour shown and described, a spiral spring connected with a buffer strap and projecting strap for the purpose described. 2nd. In a shuttle check, the frame of the contour shown and described a buffer strap and a connecting strap, a frame of the contour shown and described. 3rd. In a shuttle check, a frame of the contour shown and described, an adjusting stud, a spool and an anchor stud, as shown and described. 4th. In a shuttle check frame of the contour shown and described, an adjusting stud, a buffer strap, a spool and an adjusting stud. 5th.

In a shuttle check, the combination of the buffer strap on a spool and the spiral spring. 6th. In a shuttle check, the spiral spring

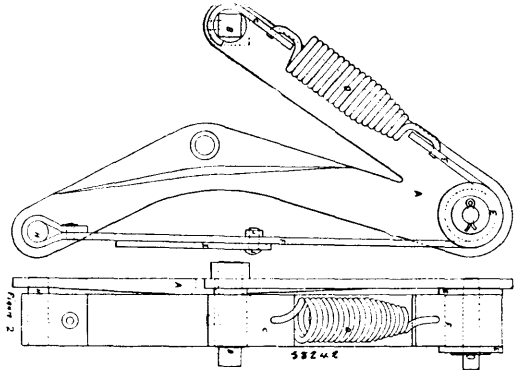

connecting strap combined with the adjusting stud as shown and described for the purpose set forth. 7th. In a shuttle check, a spiral, a buffer and a spool as shown and described, for the purpose set forth.

No. 48,243. Gauge. (Jauge.)



John P. Van Vleck, Cooksville, Wisconsin, U.S.A., 2nd December, 1897; 6 years. (Filed 29th October, 1897.)

Claim.—A portable gauge for measuring milk and other liquids, adapted to be readily transferred from one can to another, and comprising a tubular casing open at its lower end and provided with an exterior longitudinally-disposed well closed at its lower end and open at the upper end, a detachable pulley-casing mounted on top of the tubular casing, and provided at its front with an opening, a pulley mounted in the pulley-casing, a float arranged within the tubular casing, a weight arranged in the well, a strip or ribbon provided with graduations arranged on the pulley and connected with the weight and the float and adapted to withdraw the same from the well and the tubular casing when the pulley-casing is detached, to permit the parts to be washed, and a resilient catch adapted to engage the upper edge of a can, substantially as and for the purpose described.

No. 58,244. Electric Brake for Cars. (*Frein électrique de chars.*)

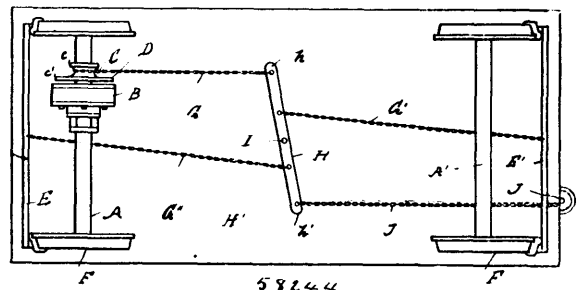

Oliver J. Menzies, Toronto, Ontario, Canada, 2nd December, 1897; 6 years. (Filed 28th August, 1897.)

Claim.—1st. In an electric brake, an electric magnet connected to the car, an armature loosely mounted on the car axle, and the brake operating mechanism connected to and actuated by the armature when attracted by the energized electro magnet, substantially as specified. 2nd. In an electric brake, an electric magnet rigidly mounted on the car axle, an armature loosely mounted on the car axle contiguous to the electric magnet, and the brake operating mechanism connected to and actuated by the armature when attracted by the energized electro magnet, substantially as specified. 3rd. In an electric brake, an electro magnet rigidly mounted on the car axle, an armature loosely mounted on the same axle contiguous to the electro magnet, the brake beams with their brake shoes, a pivoted lever, connections between the lever and brake beams, and a connection between the armature and lever, adapted to actuate the lever when the armature has been attracted by the energized

electro magnet, substantially as specified. 4th. In an electric brake, an electro magnet rigidly mounted on the car axle, an armature loosely mounted on the same axle contiguous to the electromagnet, a grooved hub for the armature, the brake beams with their brake shoes, a pivoted lever, connections between the lever and brake beams, a flexible connection between the grooved hub of the armature and the lever adapted to be wound on the hub when the armature has been attracted by the energized electro magnet, substantially as specified. 5th. In an electric brake for cars, an electric magnet consisting of a magnet frame, having a hub fitted to receive the car axle, a plurality of independent magnet spools in circuit with each other, arranged about the hub, an insulated core for each magnet spool mounted in the magnet frame, an insulated polar plate connected to the ends of the cores of the magnet spools on the outer side of the magnet frame, and an armature adapted to be attracted by the electro magnet when energized, substantially as specified. 6th. In an electric brake for cars, an electric magnet consisting of a magnet frame, having a hub fitted to receive the car axle, a plurality of independent magnet spools in circuit with each other, arranged about the hub, an insulated core for each magnet spool mounted in the magnet frame, an insulated polar plate, connected to the ends of the cores of the magnet spools on the outer side of the magnet frame, an armature adapted to be attracted by the electro magnet when energized, commutator mounted on the hub of the magnet frame opposite the polar plate, a series of terminals connected to the commutator, circuit wires, for each terminal connected to the positive and negative poles of two adjacent magnet spools, a brush holder, and brushes carried by the brush holder, substantially as specified.

No. 58,245. Tooth Brush. (Brosse à dents.)

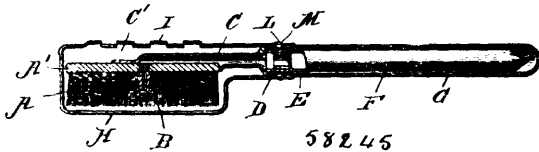

Daniel W. Tower, Grand Rapids, Michigan, U.S.A., 2nd December, 1897; 6 years. (Filed 3rd November, 1897.)

Claim.—1st. A casing for tooth-brushes, consisting of a part to inclose the stem; and a separate part to inclose the brush proper, said latter part being formed of hinged sections, whereby the brush proper may be uncovered without uncovering the stem, as specified. 2nd. A casing for tooth-brushes, consisting of a part to inclose the stem and a separate part to inclose the brush proper, said latter part being constructed of hinged sections having perforations. 3rd. In a tooth-brush, the combination with the tubular stem having a brush at one end, and a collapsible tube attached to the other end of said stem, of a sleeve encircling the latter end of the stem, and a casing inclosing said tube and detachably secured to said sleeve, substantially as described. 4th. The combination with a fountain tooth-brush, having a tube to contain the dentifrice and provided with a sleeve, of a detachable casing for said tube, engaging said sleeve and provided with a bead, and a detachable casing for the brush proper, said latter casing having a groove to receive said bead and being formed of sections hinged together at one side and provided with a catch at the other side of the casing.

No. 58,246. Sewing Machine. (Machine à coudre.)

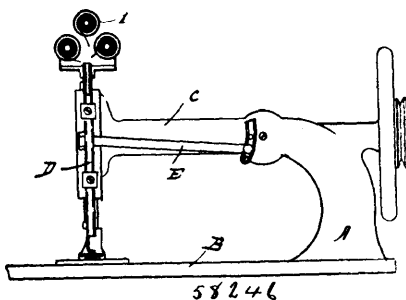

August Raussen, Covington, Kentucky, U.S.A., 2nd December, 1897; 6 years. (Filed 3rd November, 1897.)

Claim.—1st. The combination with a bifurcated presser-foot of a centrally supported tubular guide, and a secondary tubular guide located at the side of the central tubular guide, both of said guides being rigidly secured to and arranged between the members of the bifurcated foot, substantially as described. 2nd. The combination with a bifurcated presser-foot of a central tubular guide, and a curved horn, both rigidly secured to and arranged between the members of the bifurcated foot, substantially as described.

No. 58,247. Spraying Apparatus. (Appareil pulverisateur.)

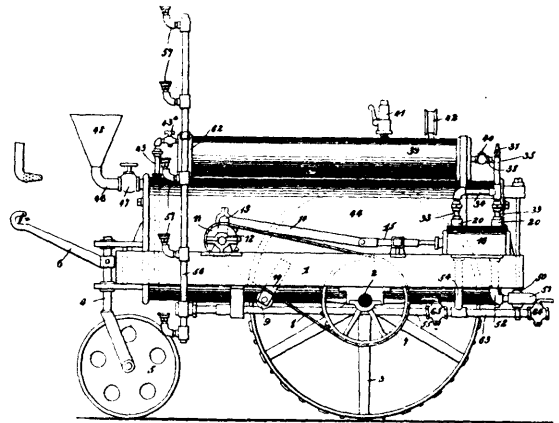

James Cameron Ollard, Tacoma, Washington, U.S.A., 2nd December, 1897; 6 years. (Filed 19th October, 1897.)

Claim.—1st. In a spraying apparatus, the combination of a frame a liquid-tank extending longitudinally along the central part thereof, discharge-pipes extending longitudinally of the frame on opposite sides of the liquid-tank, and connected thereto, means for forcing the liquid from the liquid-tank through the discharge-pipes, spraying-pipes swivelled on said discharge-pipes and arranged to swing laterally of the frame toward and from each other, a bracket mounted on the liquid-tank with its ends extending in opposite directions from the sides thereof, and notched arms pivotally connected to the spraying-pipes and having their notches arranged to engage the projecting ends of said bracket, substantially as set forth. 2nd. In a spraying apparatus, the combination of a frame, a liquid-tank extending longitudinally along the central part thereof, discharge-pipes extending on the frame at opposite sides of said liquid-tank and connected thereto, a bracket held on the upper part of the liquid-tank, an air-tank supported by said bracket and also extending longitudinally of the frame above the liquid-tank arms on said bracket projecting on opposite sides of the air-tank, a connection between the air and liquid tanks, spraying-pipes swivelled on the discharge-pipes and arranged to swing laterally of the frame, and arms pivotally connected at their outer ends to the spraying-pipes and having their inner ends adapted for adjustable connection to the projecting arms of the bracket on the liquid-tank, substantially as described.

No. 58,248. Sewing Machine. (Machine à coudre.)

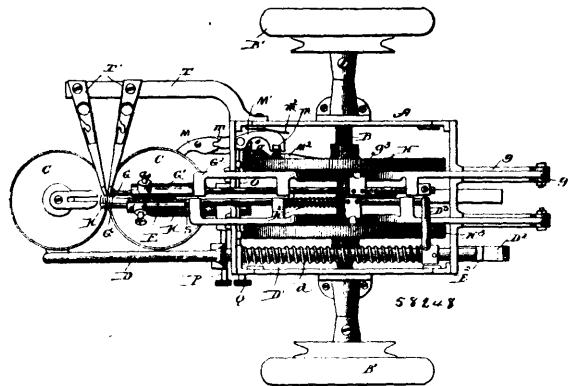

David H. Agan and Jennie Agan, New York, State of New York, U.S.A., 2nd December, 1897; 6 years. (Filed 29th October, 1897.)

Claim.—1st. In a sewing machine, the combination with the work holding and feeding mechanism, driving mechanism and reciprocatory needle bar, of two independently supported and guided loopers co-operating with the loop cast off by the needle, and spreading the same to encircle the path of the needle on both sides of the fabric, whereby the needle is caused to pass through the loop on both sides of the fabric and independent operating mechanism interposed between said loopers and the driving mechanism, substantially as described. 2nd. In a sewing machine, the combination with the work holding and feeding mechanism, the reciprocatory needle bar and the driving mechanism, of co-operating independently supported and guided loopers engaging the same loop cast off by the needle and spreading the same to encircle the path of the needle on both sides of the fabric, of independent looper carriers for

said loopers and independent cams on the driving mechanism for operating said looper carrier, substantially as described. 3rd. In a sewing machine, the combination with the work holding and feeding mechanism, reciprocating needle bar and drive shaft of the secondary looper carrier, a link interposed between said looper carrier and frame of the machine to permit of a bodily horizontal reciprocation and vertical oscillation of said secondary carrier, cams on the drive shaft for moving said secondary carrier vertically and horizontally, a primary looper carrier journaled in said secondary carrier to oscillate on its longitudinal axis, a cam and an arm on said primary carrier co-operating with the cam whereby the primary carrier is oscillated and a looper mounted in said carrier, substantially as described. 4th. In a sewing machine, the combination with the work holding and feeding mechanism, the reciprocating needle bar and drive shaft, of the secondary looper carrier pivotally supported on a link at one end, a primary looper carrier journaled to oscillate in said secondary carrier, a cam on the drive shaft for reciprocating the looper carriers horizontally, a cam disc on the drive shaft having cam grooves therein and projections on the primary and secondary looper carriers co-operating with said grooves to move said looper carriers vertically and to oscillate the primary looper carrier on its axis and a looper, substantially as described. 5th. In a sewing machine, the combination with the horizontally arranged work holding and feeding discs, reciprocating needle bar and transverse driving shaft, of a secondary looper carrier and link pivotally supporting said looper carrier at one end, vertically arranged bearing surfaces on said secondary looper carrier, a grooved cam on the driving shaft with which said vertically arranged bearing surfaces co-operate to reciprocate the looper carrier horizontally, a primary looper carrier journaled in the secondary looper carrier to oscillate on its longitudinal axis, a disc on the drive shaft having cam grooves therein and projections on the primary and secondary looper carriers respectively, for moving the secondary looper carrier vertically and oscillating the primary looper carrier on its longitudinal axis, substantially as described. 6th. In a sewing machine, the combination with the horizontally arranged work holding and feeding discs, one of said discs being movable with relation to the other, and a needle bar and driving mechanism, substantially as described, of a looper for spreading the loop cast off by the needle, an operating mechanism therefor, including a looper carrier adapted to be moved abnormally, a feed disc moving mechanism and connection between said feed disc moving mechanism and looper carrier whereby when the feed discs are separated the looper carrier is moved in unison with the movable disc, substantially as described. 7th. In a sewing machine, the combination with the fixed and movable work holding and feeding disc, the carrier for the movable disc, and means for moving said carrier and disc, of a reciprocating needle bar, a looper and looper carrier, driving mechanism for said needle bar and looper carrier, and an arm on the disc carrier co-operating with the looper carrier to move said parts in unison when the discs are separated, substantially as described. 8th. In a sewing machine, the combination with the horizontally arranged work holding and feeding discs, one of said discs being movable with relation to the other, a disc support or carrier with means for moving the same, a driving shaft, a reciprocating needle bar driven from said shaft, of a looper and primary looper carrier held in working position by spring pressure, mechanism for operating said looper carrier, and an arm on the feeding disc support or carrier co-operating with the looper carrier to move the same when the feeding discs are separated, substantially as described. 9th. In a sewing machine, the combination with the stitch-forming mechanism and the work holding and feeding discs, of a reciprocating feeding pawl co-operating with one of said discs to rotate the same, and a lock engaging the disc for holding the same against retrograde movement, with connection between said lock and driving mechanism whereby the lock is moved out of contact with the disc by the driving mechanism during the time the feeding pawl is operative, substantially as described. 10th. In a sewing machine, the combination with the stitch-forming mechanism, driving shaft and work holding and feeding discs, of a feeding pawl co-operating with one of said discs, a lock for holding said disc against retrograde movement, and cams rotated by the drive shaft and co-operating with the feeding and locking mechanism to alternately throw the same into and out of engagement with the disc, substantially as described. 11th. In a sewing machine, the combination with the drive shaft, stitch-forming mechanism and rotary work holding and feeding discs, of a feeding pawl co-operating with one of the discs, an operating mechanism for said pawl, a cam on the drive shaft co-operating with said pawl operating mechanism, a locking pawl co-operating with the disc to prevent retrograde movement thereof, an operating lever controlling said locking pawl, and a cam carried by the drive shaft co-operating with said operating lever to release the pawl when the feeding mechanism is operative, substantially as described. 12th. In a sewing machine, the combination with the stitch-forming mechanism, drive shaft and rotary work holding and feeding discs, of a pivoted pawl carrier, a pawl pivotally mounted on said carrier, an adjustable stop for limiting the movement of the pawl carrier, a cam on the drive shaft, a spring-pressed pawl operator having a projection lying in the path of said cam, and an adjustable stop for limiting the movement of said pawl operator, substantially as described. 13th. In a sewing machine, the combination with the stitch-forming mechanism, drive shaft and work holding and feeding discs, a pawl carrier

pivoted concentrically with one of said discs, a pivoted pawl mounted on said carrier and co-operating with the disc, a spring for holding the pawl carrier in normal position, a stop for limiting the movement of the pawl carrier to regulate the extent of feed, a pawl operating slide co-operating with the rear end of the pawl and controlling its engagement with the disc, a cam on the drive shaft, and a projection on the pawl operating slide co-operating with said cam, substantially as described.

No. 58,249. Letter Box Case and Memorandum.
(*Etui pour casiers des bureaux de postes.*)

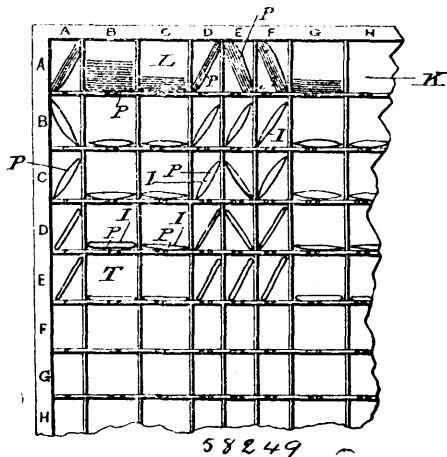

David J. Ayres, Keokuk, Iowa, U.S.A., 2nd December, 1897; 6 years. (Filed 1st November, 1897.)

Claim.—1st. A post-office case having cells for letters or packages, each provided with an indicator adapted to be handled with its letters and bearing indicia of the names or classes of letters the cell is devoted to, on one face, and on another face a surface prepared for writing and erasing memorandums, and intermediately a pocket for cards or slips, and having notches on its edges to receive elastic straps for letters, substantially as set forth. 2nd. A post-office case having cells for letters or packages, each provided with an indicator adapted to be handled with its letters and to remain permanently therewith in the absence of letters to avoid mistakes. 3rd. A post-office case having cells for letters or packages, each cell provided with an indicator adapted to be handled with its letters and bearing indicia of the names or classes of letters to which the cell is devoted on one face, and a surface on the other face adapted for the writing and erasure of memorandums, and intermediately a pocket to retain memorandum cards or slips. 4th. A post-office case having cells for letters or packages, each cell provided with an indicator adapted to be handled with its letters and to remain permanently with it, and bearing initial letters or indicia of the names or classes of letters to which the cell is devoted. 5th. A post-office case having cells for letters or packages, each cell provided with an indicator adapted to be handled with its letters and to remain permanently with it and bearing on one face a label or index of the names or class of letters to which the cell is devoted, and on another face a prepared surface adapted for the writing and erasure of names.

No. 58,250. Curling Iron Holder. (*Porte-fer à friser.*)

William E. Fuller, New Haven, Connecticut, U.S.A., 2nd December, 1897; 6 years. (Filed 1st November, 1897.)

Claim.—1st. In a curling iron holder, the combination with a sleeve adapted to be applied to a gas burner, of a frame hinged to said sleeve and comprising two sections, and means connecting said sections whereby they may be either held in a raised operative position or permitted to fall down beside the burner at will, substantially as described. 2nd. In a curling iron holder, the combination with a sleeve adapted to be applied to a gas burner, of a split cylindrical spring clamp located in said sleeve and having one of its edges secured firmly to said sleeve, and a curling iron holding frame mounted on said sleeve, substantially as described. 3rd. In a curling iron holder, the combination with a sleeve adapted to be applied to a gas burner, of a frame hinged to said sleeve and provided with a hook, another frame also hinged to said sleeve and provided with an eye adapted to be engaged by said hook to hold the frames in an elevated position, and a third frame pivotally connecting the two aforementioned frames, substantially as described. 4th. In a curling iron holder, the combination with a sleeve adapted to be applied to a gas burner, of two frames hinged thereto and pro-

vided respectively with an eye and a hook adapted to enter said eye, and a triangular frame connecting the upper end of the said frames

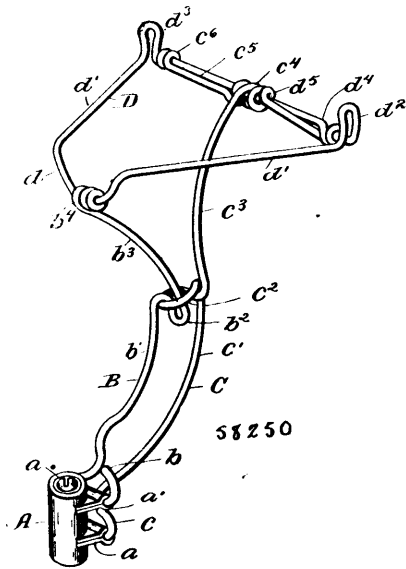

and formed with a dip adapted to receive the metallic portion of the iron and upwardly projecting loops adapted to hold the handle in position on said frame, substantially as described.

No. 58,251. Ratchet Brace. (Percoir à rochet.)

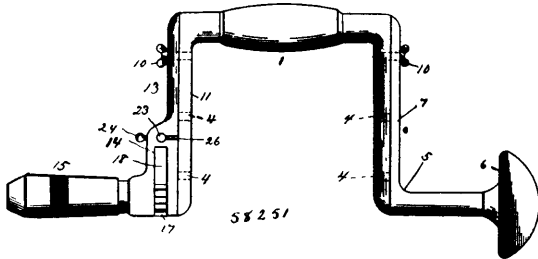

Harris H. Quinby, South Omaha, Nebraska, U.S.A., 2nd December, 1897; 6 years. (Filed 3rd November, 1897.)

Claim—In a brace, the combination with a sweep, of a chuck or bit-holder journaled therein, a ratchet-wheel connected to the bit-holder, pivoted pawls adapted for engagement with the ratchet-wheel on opposite sides thereof, and having cam surfaces on their heels, a spring interposed between the heels and the pawls, a rotatable spindle extending transversely of the pawls and having a straight handle projecting therefrom, and independent locking pins projecting from the spindle at right angles thereto, and disposed at right angles to each other, one locking-pin being adapted to engage with the cam of one pawl when the other locking-pin is disengaged from the remaining pawl.

No. 58,252. Form Cabinet. (Cabinet.)

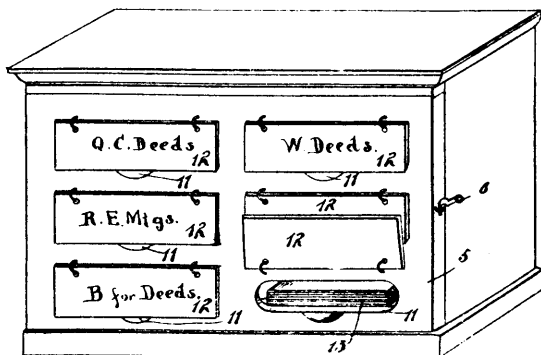

Arthur F. Crandall and George W. Byrnes, both of Beresford, South Dakota, U.S.A., 2nd December, 1897; 6 years. (Filed 5th November, 1897.)

Claim.—1st. A cabinet having a pad support adjacent to one side, a hook attached to the opposite side of the cabinet, and a pad having one portion rested on the pad support and having the other portion provided with an eye adapted to engage the hook on the cabinet. 2nd. A cabinet having a bar extending horizontally across one side, a hook secured to the opposite side of the cabinet, and a pad spanning the cabinet between the hook and bar, one edge of the pad being rested on the bar and the other edge of the pad having an eye capable of engagement with the hook, whereby to permit tugging edgewise on the pad to remove a single leaf therefrom. 3rd. A cabinet having a door closing one side and provided with an opening, a hinged plate hanging to normally cover the opening, a bar secured in the cabinet adjacent to the door and to the opening therein, a hook secured to the inner face of that wall of the cabinet which is opposite the door, and a pad provided with an eye, the eye receiving the hook and the opposite edge of the pad resting on the bar. 4th. A pad having a series of superposed leaves, a back-plate laid against the leaves, a top-plate of less size than that of the back-plate, the top-plate being laid on the leaves, and a wire running through the top and back-plates and through the leaves and rigidly holding such parts together, an intermediate portion of the wire being run outward from the pad and looped upon an eye. 5th. A cabinet provided with a pad raised at one side and with a plurality of pad securing devices at an opposite side, the pad securing devices being approximately in the same plane, and the cabinet being capable of holding the pad with one edge rested on the pad support and the opposite edge held by the pad securing devices whereby the pad is prevented from edgewise movement.

No. 58,253. Net Lifting Machine.

(Machine à lever les réts.)

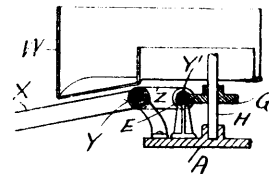

William F. Ahearn and Peter Gagnon, both of Two Rivers, Wisconsin, U.S.A., 2nd December, 1897; 6 years. (Filed 5th November, 1897.)

Claim.—1st. A net-lifting machine comprising a rotative shaft, arms radiating from the shaft, net-guards carried by the arms, and reciprocative net-gripping plungers operative in conjunction with the guards. 2nd. A net-lifting machine comprising a rotative shaft, arms radiating from the shaft, net-guards carried by the arms, levers fulcrumed on said arms, plungers that being connected to the levers operate in conjunction with the net-guards, and suitable means for automatically rocking said levers at predetermined intervals. 3rd. A net-lifting machine comprising a rotative shaft, arms radiating from the shaft, net-guards carried by the arms, levers fulcrumed on said arms, plungers that being connected to the levers operate in conjunction with the net-guards, and fixed cams arranged to cause a rock of said levers at predetermined intervals. 4th. A net-lifting machine comprising a rotative shaft, arms radiating from the shaft, net-guards that are carried by the arms and comprise fingers radiating in opposite directions from a groove, levers fulcrumed on said arms, plungers that being connected to the levers extend through the guards into the grooves of the same, and suitable means for rocking said levers at predetermined intervals. 5th. A net-lifting machine comprising a rotative shaft, arms radiating from the shaft, net-guards carried by the arms, levers fulcrumed on said arms, suitable means for rocking the levers at predetermined intervals, and plungers consisting of bosses at the outer ends of said levers, sleeves that being set in the bosses reciprocate in the net-guards, grip-plugs arranged in the sleeves to extend therefrom, and screws arranged to adjust the plugs. 6th. A net-lifting machine comprising a rotative shaft, arms radiating from the shaft, net-guards carried by the arms, levers fulcrumed on said arms, plungers that being connected to outer ends of said levers operate in conjunction with the net-guards, antifriction-rollers on the inner ends of the aforesaid levers, and cams arranged to oppose the antifriction-rollers in opposite directions, the rise of one cam being opposite the depression of the other. 7th. A net-lifting machine comprising a hollow rotative shaft, a steam-supply pipe in communication with the shaft, a series of hollow radial arms also in communication with the shaft, net-guards that being carried on the arms have steam-outlets in register with similar outlets pertaining to said arms, and reciprocative grip-plungers operative in conjunction with the net-guards. 8th. A net-lifting machine comprising a hollow rotative shaft, a valve-controlled pipe for exhaust-steam from an engine employed to drive said machine, a valve-controlled branch of said pipe communicating with the hollow shaft, a series of hollow radial arms also communicating with said shaft, net-guards that being carried on the arms have steam-outlets in register with similar outlets pertaining to said arms and reciprocative grip-plungers operative in conjunction with the net-guards. 9th. A net-lifting

machine comprising a series of rotative arms, net-guards carried by the arms, reciprocative net-gripping plungers operating at predetermined intervals in conjunction with the net-guards, and a wind-guard trough for the slack of an incoming net. 10th. A net-lifting machine comprising a series of rotative arms, net-guards carried by the arms, reciprocative net-gripping plungers operating at predetermined intervals in conjunction with the net-guards, guide-rollers for an incoming net, and a wind-guard trough for the slack of said net. 11th. A net-lifting machine comprising a series of rotative arms, net-guards carried by the arms, reciprocative net-gripping plungers operating at predetermined intervals in conjunction with the net-guards, a trough for the slack of an incoming net, and a conveyer arranged to receive said net from the trough. 12th. A net-lifting machine comprising a suitable frame, a rotary steam-engine, a shaft in gear with the engine, arms radiating from the shaft, net-guards carried by the arms, levers fulcrumed on said arms, plungers carried by the levers to operate in conjunction with the net-guards, suitable means for rocking the levers at predetermined intervals, guide-rollers for an incoming net, and a trough for the slack of said net.

No. 58,254. Antiseptic Compound.

(Composé antiseptique.)

Thomas W. McCue, Akron, Ohio, U.S.A., 2nd December, 1897; 6 years. (Filed 11th December, 1896.)

Claim.—A composition of matter consisting of a mixture of finely powdered litharge and cereal flour, with or without other ingredients, in substantially the proportion and for the purpose specified.

No. 58,255. Soldering Iron. (Fer à souder.)

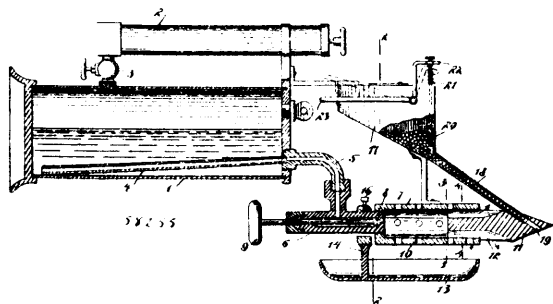

John C. Barber and Joanna Barber, both of Phillipsburg, Warren Co., New Jersey, U.S.A., 2nd December, 1897; 6 years. (Filed 20th October, 1897.)

Claim.—1st. A soldering iron, comprising a tank for gasoline or the like, means for forcing air into the same, a burner having communication with the tank, a valve for controlling said communication, a soldering iron mounted in the burner, a container for solder, and a raceway leading from said container to the soldering iron, substantially as specified. 2nd. A soldering iron, comprising a tank for gasoline or the like, a pump for forcing air into the same, a burner having communication with the tank, a valve for controlling said communication, a soldering iron mounted in the burner, a container for solder, and an inclined raceway leading from said container to an opening through the soldering iron, substantially as specified. 3rd. A soldering iron, comprising a tank for gasoline or the like, a pipe running longitudinally through said tank at its bottom, a pump for forcing air into the tank, a burner communicating with the tank, a valve for controlling said communication, a soldering iron supported in the forward end of the burner having a hole diagonally through it, a container for solder pellets, a raceway leading from the said container to the opening through the soldering iron, a valve for controlling the communication between the raceway and container, a spring for normally holding said valve open, and a fulcrumed lever for closing said valve, substantially as specified.

No. 58,256. Spectacle or Eyeglass. (Lunettes et lorgnons.)

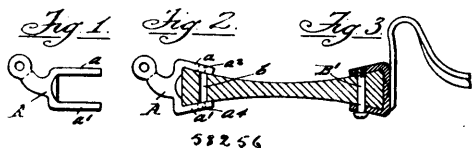

The Interchangeable Frameless Spectacle Co., assignee of Walter Scott Essick, all of Reading, Pennsylvania, U.S.A., 2nd December, 1897; 6 years. (Filed 21st October, 1897.)

Claim.—1st. In spectacles or eyeglasses, a frameless lens and a metallic fitting thereto having one clamping ear only contacting with one face of the lens, and a clamping screw passing through a perforation in the lens and engaging said ear, substantially as set forth.

2nd. A fitting for frameless spectacle lens, having one clamping ear only adapted to bear against one face of the lens, a shoulder forming a stop against the edge of the lens and a perforation in said ear for a clamping screw, substantially as set forth. 3rd. In spectacles or eyeglasses, a frameless lens and a metallic fitting thereto having one clamping ear only to contact with one face of the lens, a clamping screw passing through a perforation in the lens and engaging said ear, and a washer interposed between the head of the screw and the opposite face of the lens and in which said head is socketed, substantially as set forth. 4th. A perforated spectacle lens having a fitting clamped against one face thereof by means of a clamping screw passing through the perforation in the lens, and a washer for said screw adjustably seated against the opposite face of the lens, substantially as set forth. 5th. A perforated spectacle lens having a fitting clamped thereto by means of a clamping screw engaging a perforated ear of said fitting, the inner face of which ear is recessed to form an outer bearing against the lens and to leave a portion of the lens immediately surrounding the perforation free from pressure, substantially as set forth.

No. 58,257. Milling Machine. (Machine à travailler les métaux.)

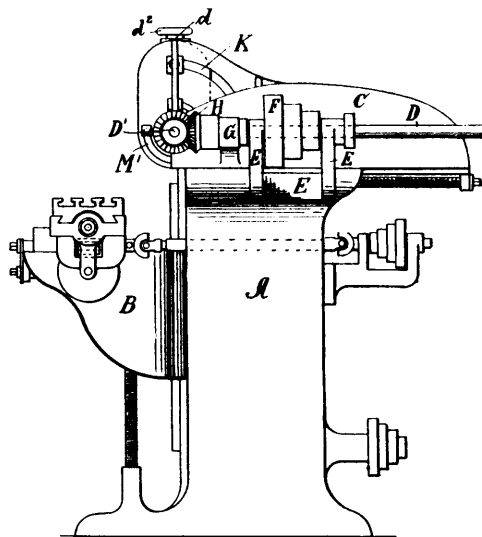

58257

Charles E. Van Norman, Springfield, Massachusetts, U.S.A., 2nd December, 1897; 6 years. (Filed 2nd November, 1897.)

Claim.—1st. In a milling machine, a main head horizontally adjustable on the machine, an auxiliary head attached for rotatable adjustment to the side of said main head, a tool-carrying spindle supported to rotate in said auxiliary head, a shaft supported in said main head at right angles to said spindle, gear connections between said spindle and shaft, combined with a driving-shaft moving horizontally with said main head, and a driving-pulley on said shaft supported on the base of the machine, substantially as set forth. 2nd. In a milling machine, a main head horizontally adjustable on the machine, an auxiliary head attached for rotatable adjustment to the side of said main head, a tool-carrying spindle supported to rotate in said auxiliary head, a shaft supported in said main head at right angles to said spindle, gear connections between said spindle and shaft, combined with a second driving shaft D, supported in bearings fixed to the base A, of the machine, having geared connection with the shaft in said main head, a driving pulley on said shaft D, having a spline and groove connection therewith, and an arm on said main head engaging said driving-shaft D, whereby the latter and said main head have coinciding horizontal movements, substantially as set forth. 3rd. In a milling machine, a main head horizontally adjustable on the machine, an auxiliary head attached for rotatable adjustment to the side of the main head in a plane at right angles to the movement of the work-holding table and parallel with the movement of the main head to which it is attached, a tool-carrying spindle supported to rotate in said auxiliary head, a shaft supported in said main head at right angles to said spindle and extending through the side wall on which the auxiliary head is pivoted, gear connections between said shaft and spindle, combined with driving mechanism for rotating said shaft, substantially as set forth. 4th. A main horizontally adjustable head provided with a vertical wall upon one side, and suitable bearings in or upon its front end for the driving-shaft for the tool-spindle, combined with a rotatable head pivoted upon the said vertical wall, means for securing the rotatable head in place, the driving-shaft for the tool-spindle, journaled upon the front end of the main head and having one end extended through both the vertical wall and the ro-

tatable head, and provided with a gear, and a tool-carrying spindle mounted upon the rotatable head and provided with a gear to engage with the one on the end of the driving-shaft, substantially as shown. 5th. A milling machine provided with the main horizontally adjustable head having a vertical wall on one side thereof, combined with a rotatable head pivoted upon said wall for rotatable adjustment in a plane parallel with the movement of the main head, and at right angles to the movement of the work-holding table of the machine, a tool-carrying spindle supported to rotate in said auxiliary head, and mechanism for rotating said tool-carrying spindle, substantially as set forth. 6th. In a milling machine, the work-holding bed combined with a frame having a vertical wall on a plane at right angles to the longitudinal movement of said bed, a flat plate pivoted upon said wall, a spindle-supported in suitable bearings on said plate, a pulley on said spindle, a driving-belt therefor, an arm with guide-pulleys journaled thereon, adapted to be moved in a plane parallel with said plate, means for moving said belt, and means for securing said flat plate to said vertical wall in any desired position, substantially as described.

No. 58,258. Pickle Fork and Olive Pick.
(*Fourchette à cornichons, etc.*)



Myer Myers, Cornwall, Ontario, Canada, 2nd December, 1897; 6 years. (Filed 14th September, 1897.)

Claim.—As an article of manufacture, a pickle or slug pick, composed of a suitable handle having one of its ends terminated by a pointed spiral, as and for the purpose herein before set forth.

No. 58,259. Stencilling Device.
(*Appareil pour peindre au patron.*)

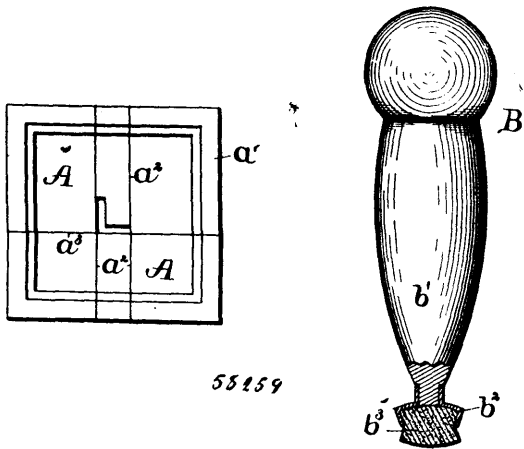

Philip Mason Cabell, Wilmington, Delaware, U.S.A., 3rd December, 1897; 6 years. (Filed 13th November, 1897.)

Claim.—1st. The herein described improvement in the art of stencilling, which consists in applying and working in the colouring-matter through the openings in the stencil plate, by successive pressures of a compressible or elastic material carrying the colouring-matter. 2nd. A tamping-stick for stencilling, consisting of a holder and a colouring-applying tip formed of some elastic or compressible substance to which the colouring-matter to be applied will adhere. 3rd. A stencil or tamping plate in which the pattern to be printed is cut, and on which by visible indications, the exact width of the letter or pattern is shown.

No. 58,260. Mining Shaft. (Puits de mines.)

Charles Nylin and Charles Nelson, both of Chicago, Illinois, U.S.A., 3rd December, 1897; 6 years. (Filed 11th November, 1897.)

Claim.—1st. A mining shaft comprising a plurality of telescoping sections, arranged to be extended to the bottom of a body of water to form a water-tight enclosure, for the purpose of removing the water from within, so as to obtain access to the bottom, substantially as described. 2nd. A mining shaft comprising a plurality of telescoping sections arranged to be extended to the bottom of a body of water to form a water-tight enclosure, for the purpose of removing the water from within, so as to obtain access to the bottom, in combination with a float adapted to support the upper section at the surface of said body of water, substantially as described. 3rd. A mining shaft comprising a plurality of telescop-

ing sections arranged to be extended to the bottom of a body of water to form a water-tight enclosure, for the purpose of removing

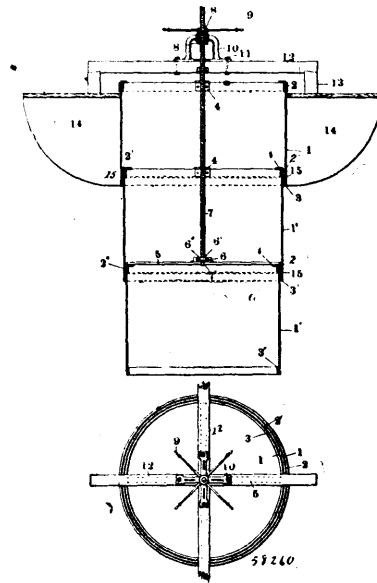

the water from within, so as to obtain access to the bottom, in combination with a float adapted to support the upper section of the surface of said body of water, and means upon said float for extending and drawing up the other sections, substantially as described. 4th. A mining shaft comprising a plurality of telescoping sections, arranged to be extended to the bottom of a body of water to form a water-tight enclosure, for the purpose of removing the water from within, so as to obtain access to the bottom, in combination with means for supporting the upper section at the surface of said body of water, and means secured to said upper section for extending and drawing up the other sections, substantially as described. 5th. A portable mining shaft, comprising a plurality of telescoping sections, arranged to be extended to the bottom of a body of water, to form a water-tight enclosure for the purpose of removing the water from within, so as to obtain access to the bottom, in combination with means for supporting and conveying said shaft, substantially as described. 6th. A portable mining shaft comprising a plurality of telescoping sections, arranged to be extended to the bottom of a body of water, for the purpose of removing the water from within, so as to obtain access to the bottom, said sections having oppositely projecting flanges for engaging each other, with suitable packing between said flanges adapted to form water-tight joints when said flanges are in engagement, substantially as described.

No. 58,261. Seed-Drill Disc Shoe.
(*Sabot pour semailles en lignes.*)

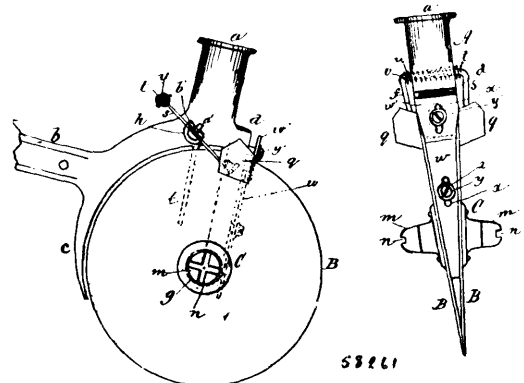

William Stephenson, Morris, Manitoba, Canada, 3rd December, 1897; 6 years. (Filed 14th July, 1897.)

Claim.—1st. In a seed-drill disc shoe, the grain spout having its grain conduit in front of the axles, an oil conduit and oil reservoir in rear of the grain spout, hollow tapering axles enclosing the oil chamber, a shield in front of the discs; lugs for side scrapers, rear lugs on the rear oil conduit for central scrapers, and draw bar connection in front, all cast in one piece, substantially as specified. 2nd. In a seed-drill disc shoe, the grain spout constructed in front

of the axles, and the oil conduit and oil reservoir in rear of the grain spout, substantially as specified. 3rd. In a seed-drill disc shoe, the discs constructed with an outward taper on the inside of each disc a short distance inwards from the outer edge, substantially as specified. 4th. In a seed-drill disc-shoe, side scrapers pivoted to levers, which in turn are pivoted to lugs on the grain spout, the outer ends of the levers being bent inwards and a spiral spring surrounding both bent ends to press them apart, and so cause the scrapers to impinge on the discs, substantially as specified. 5th. The levers or arms of the side scrapers provided with holes and a pin for the same to alter the tension of the spring surrounding the ends of scraper levers, substantially as specified. 6th. The combination of two adjustable central scrapers between the discs to clean the inner surfaces of the same, substantially as described. 7th. The combination of the double-motioned side scrapers *q, q*, levers *s, s*, spiral spring *t*, and grain spout *A*, substantially as specified. 8th. In combination with the oil chamber in the hollow axles, of the notches cut in the outer ends of said axles for the oil to exude to the axle bearings, substantially as described. 9th. The combination of the screw-threaded hubs on the discs, and cone-shaped internal caps to fit thereon, the interior ends of the caps acting as auxiliary oil chambers in connection with the main oil chamber in the centre of the axles, substantially as specified.

No. 58,262. Rock Drill. (Barre à mine.)

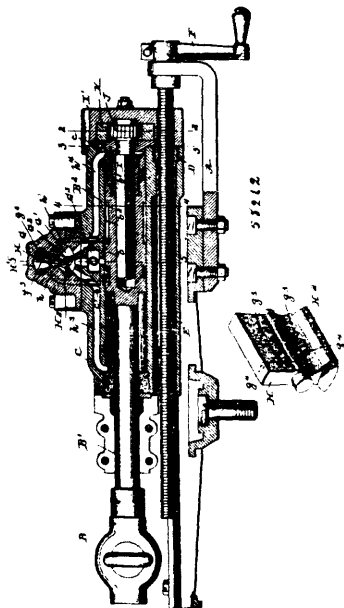

John Morris Hamor, Philadelphia, Pennsylvania, U.S.A., 3rd December, 1897; 6 years. (Filed 17th November, 1897.)

Claim.—1st. In an automatic engine, in combination, a cylinder, a piston having a cut away portion, a valve-casing having two chambers, one directly in connection with the source of pressure supply and exhaust, the other having two passages leading to the cylinder, a valve in one chamber and a valve-piston in the other, and passages leading from the valve chamber to the valve-piston chamber on opposite sides of the valve-piston, and passages leading from the valve chamber to opposite ends of the piston chamber. 2nd. In a rock drill, in combination, a cylinder, a piston in said cylinder, and pressure and exhaust passages for controlling the reciprocation of said piston, a spindle upon which said piston is adapted to reciprocate, and with which it is adapted to rotate, a ratchet mounted upon said spindle, a ring provided with a bearing upon which it is adapted to rotate concentric with the piston rotation, and connection between said ring and the spindle whereby when the ring is moved in one direction the spindle is rotated, a secondary piston connected with said ring, a piston chamber for said piston, and connection between opposite sides of said piston and the main cylinder adjacent to the pressure and exhaust passages. 3rd. In a rock drill, in combination, a cylinder, a piston in said cylinder, and pressure and exhaust passages for controlling the reciprocation of said piston, a spindle upon which said piston is adapted to reciprocate, and with which it is adapted to rotate, a ratchet mounted upon said spindle, a ring provided with a bearing upon which it is adapted to rotate concentric with the piston rotation, a pawl connected with said ring adapted to co-act with said ratchet, a secondary piston connected with said ring, a piston chamber for said piston, and connection between opposite sides of said piston and the main cylinder adjacent to the pressure and exhaust passages, whereby when in the operation of the main piston pressure is admitted to one side of the secondary piston the pawl is moved into

operative position, and when pressure is admitted to the opposite side of said secondary piston the pawl is operated to turn the ratchet, and with it the main piston.

No. 58,263. Lasting Machine. (Machine à enformer.)

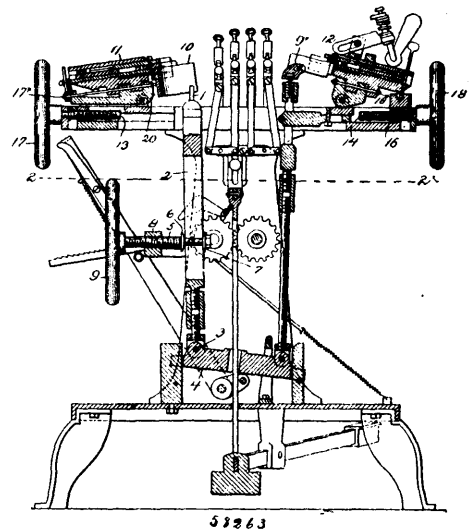

Walter Shaw, Boston, Massachusetts, U.S.A., 3rd December, 1897; 6 years. (Filed 17th November, 1897.)

Claim.—In a lasting machine, the combination of a swinging heel-post provided with a heel-pin, means for raising and lowering the heel-post, a screw engaging the heel-pin post, and mounted in a stationary bearing, substantially as and for the purpose set forth.

No. 58,264. Window. (Fenêtre.)

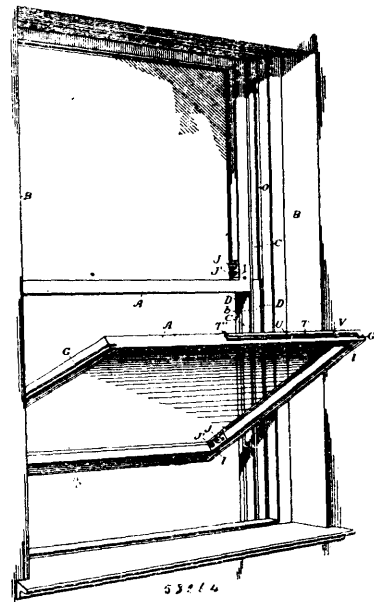

Louis Proll, Charles Milton Depew, Eugene Watson Hawley, all of San Francisco, California, U.S.A., 3rd December, 1897; 6 years. (Filed 17th November, 1897.)

Claim.—1st. In a window, vertically slidablesashes, pieces fitting channels between the parting strips in the window casing, pivot pins by which the sashes are connected with the slides and turnable about the pins, grooves or channels made in the slides and the edges of the sashes in line with each other vertically, slidables strips fitting said grooves or channels having diagonal slots movable upon pins at the upper and lower ends, whereby the upward and diagonal movement of said strips upon the pins depresses them into the sash slots and disengages them from the slides and the downward movement correspondingly projects them from the sashes and causes them to

engage and connect both the sashes and slides, and levers fulcrumed to the sashes, each one having one end to engage one of the strips, and the opposite end projecting through the inner edge of the sash for raising said strips to disengage. 2nd. In a window, vertically slidable sashes, independent pieces slidable in guides or channels in the window casings and pivot pins by which the sashes are turnably connected therewith, grooves or channels made in the slides and in the sashes, slidable strips fitting said grooves or channels having diagonal slots at the top and bottom, and stationary pins extending into the slots whereby the upward movement of the strips disengages them from the sliding pieces to which the sashes are pivoted and the downward movement causes them to be projected and engaged therewith, levers engaging said strips projecting through the inner edges of the sashes and corresponding projections fixed to the sashes with relation to the lever M so that the two may be grasped simultaneously to form a purchase to operate the levers. 3rd. In a window, vertically sliding sashes, corresponding slides fitting grooves or channels in the casing and slots made in the slides and the edges of the sashes with strips movable to engage the two or disengage them, pivot pins connecting the sashes with the slides, whereby the sashes are turnable about said pins, and extensions of the pins outwardly whereby they are fixed to the slides, said extensions forming attachments for the counterweight cords or chains. 4th. In a window, vertically slidable sashes detachably engaged with slides which are adapted to travel in grooves or channels formed in the window casing, pivot pins fixed to the slides and extending into sockets in the sashes whereby the latter are turnable upon said pins when the locking devices between the sash and the slides are disengaged, extensions from the pivot pins having sockets adapted to receive enlarged heads upon the chain or cord whereby the latter is connected with the pivot pins and slides. 5th. In a window, vertically slidable sashes, slides fitting in grooves or channels in the casing, pivot pins uniting the slides with the sashes whereby the sashes may be turned horizontally about said pivot pins, strips fitting channels made in line with each other in the slides and the sashes, inclined slots made in the strips and slidable upon fixed pins with means whereby the strips may be raised and sunk into the channels in the sashes so as to disengage them from the slides, or allowed to drop and be projected from the sashes and engaged with the slides, locking levers fulcrumed to the top of the lower sashes having projections adapted to engage with the lower rail of the upper sash, and inclined lugs upon the locking strips adapted to engage the lever and turn it to unlock the sashes when the strips are raised to disengage the sashes from the slides, and a spring whereby the lever is actuated to again lock the sashes when the strips are allowed to drop and connect the sashes and slides.

No. 58,265. Apparatus for Drawing Glass Tubing.
(Appareil pour laminier les tuyaux en verre.)

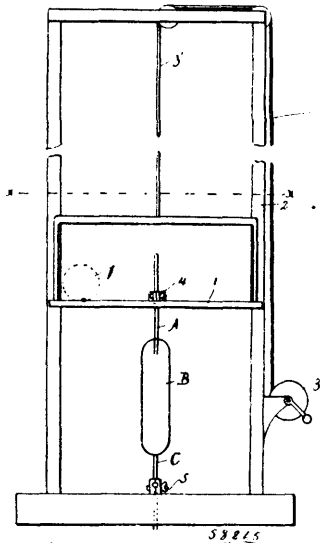

Arthur Houghton Corning, New York, State of New York, U.S.A., 3rd December, 1897; 6 years. (Filed 15th November, 1897.)

Claim.—1st. The hereinbefore described process of drawing glass tubes, which consists in forming a hollow blank and drawing out the said blank in a vertical direction at a controllable speed, whereby the blank is drawn out into a uniform tube, substantially as described. 2nd. The hereinbefore described process of forming glass tubes, which consists in forming a hollow blank upon the end of a blow-pipe, securing the said pipe against twisting, attaching the free end of the blank to a pontee iron held against twisting, and

separating the pontee and blow-pipe vertically, substantially as described. 3rd. In a device for drawing glass tubes from hollow blanks, the combination with vertical guides, of a cross head, a frame moving in the guides, the cross head and frame being adapted to be secured to the opposite ends of the blank, and means for moving the frame away from the cross head, substantially as described. 4th. In a device for drawing glass tubes from hollow blanks, the combination with a frame and a cross head to hold the opposite ends of the blank, the one located above the other, of means for moving the frame vertically and away from the cross head, substantially as described.

No. 58,266. Fruit Picker.

(Machine pour cueillir les fruits.)

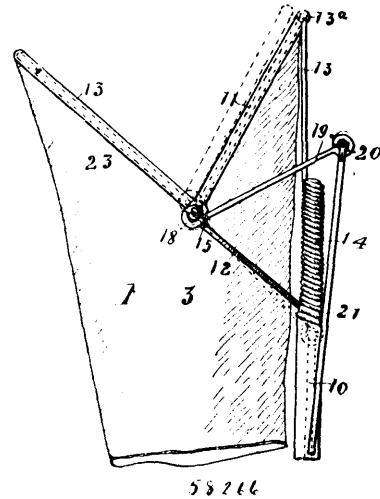

Robert Alexander Anderson, Mount Lehman, British Columbia, Canada, 3rd December, 1897; 6 years. (Filed 17th November, 1897.)

Claim.—1st. In a fruit picker having a pole with a jaw rigidly secured to the one end thereof, a jaw 16 movably hinged to the fixed jaw and a lever 19 forming an integral part of the said jaw 16, and means for connecting the lever 19 with the opposite end of said pole, whereby the jaw 16 may be opened and closed as set forth. 2nd. In a fruit picker having a pair of jaws secured to the end of a pole and a cloth tubing secured to the said jaws, a jaw 16 pivotally hinged to suitable supports on the base of the fixed jaw 11, the said supports being deflected from the plane of the pole, a lever 19 connecting with the movable jaw 16 and connecting with a connecting-rod 21, and means whereby the said rod 21 may open and close the movable jaw 16, substantially as specified.

No. 58,267. Garment. (Vêtement.)

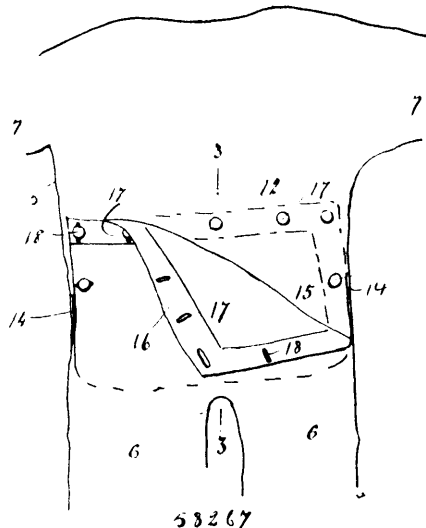

Joseph John Westgate, Montreal, Quebec, Canada, 3rd December, 1897; 6 years. (Filed 17th November, 1897.)

Claim.—1st. An under garment made in one piece comprising a body portion and arm and leg portions, the body portion having an

opening in the lower back portion thereof with a flap adapted to cover that portion of the body adjacent to said opening, for the purpose set forth. 2nd. An under garment made in one piece comprising a body portion and arm and leg portions, the body portion having an opening in the lower back portion thereof, with a flap extending within said opening and adapted to cover that portion of the body adjacent to said opening, for the purpose set forth. 3rd. An under garment made in one piece comprising a body portion and arm and leg portions, the body portion having a transverse opening across the back or buttock with covering flap, extending downwardly within said opening, a second flap extending upwardly over said covering flap and detachably connected to the back of said garment, for the purpose set forth. 4th. An under garment made in one piece comprising a front body portion 13, leg and arm portions 6, 6, and 7, 7, respectively, a front opening 8, a back body portion 12, and flaps 15 and 16, substantially as shown and for the purpose set forth.

No. 58,268. Horse Cleaner.

(Appareil à nettoyer les chevaux.)

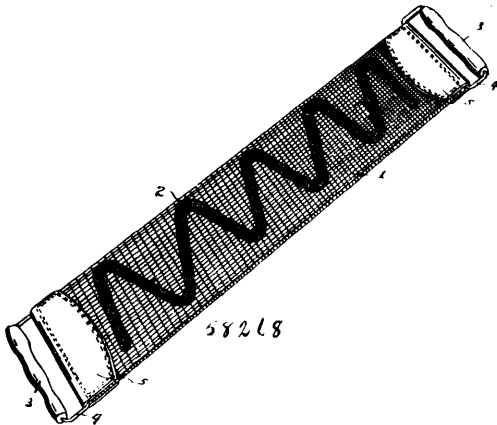

Patrick M. Donahoe, Piatteville, Wisconsin, U.S.A., 3rd December, 1897; 6 years. (Filed 17th November, 1897.)

Claim.—1st. A horse-cleaner, consisting of a band of canvas or other suitable fabric, ribs on each side thereof formed of soft material, and handles at each end thereof. 2nd. A horse-cleaner, consisting of a band of canvas or other suitable fabric, ribs on each side thereof formed by looped strips of cord or rope, and handles secured to each end of said band, mounted to turn upon strips of wire which are themselves secured in place by strips of leather, sewed or otherwise, attached to said band.

No. 58,269. Miner's Pick. (Pic pour mineurs.)

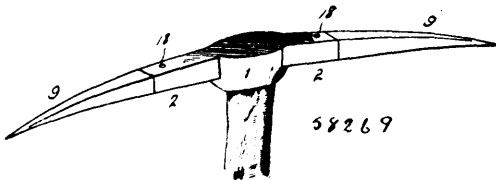

William Henry Kelso, Butte, Montana, U.S.A., 3rd December, 1897; 6 years. (Filed 17th November, 1897.)

Claim.—A miner's pick, comprising the eye 1, the integral arm 2 formed with the socket 3, having orifices 7 in combination with the detachable point 9, having the integral shank 10 provided with the longitudinally-curved orifice 17 and the pin 18, whereby when the shank 10 is inserted in said socket and its inner end abutting against the end wall thereof and the pin driven through the orifices 7 and 17, a portion of the said pin will be bent or knocked out of alignment with the orifices, substantially as set forth.

No. 58,270. Dunnage Bag and Sleeping Stretcher.

(Sac de fardage et civière.)

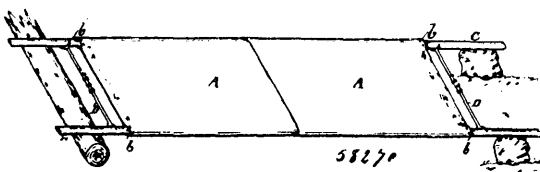

William Innes Paterson, Victoria, British Columbia, 3rd December, 1897; 6 years. (Filed 19th November, 1897.)

Claim.—The combination in a dunnage bag or bags, of openings to receive poles for stretching, and metallic stretchers for keeping the poles apart, substantially as and for the purpose hereinbefore set forth.

No. 58,271. Window Lifter and Lock.

(Levee arrêtc-fenêtre.)

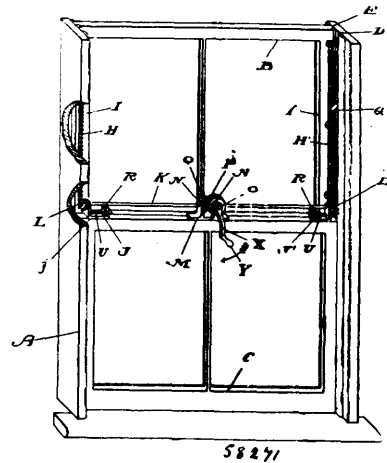

David Draper, Belhaven, Ontario, Canada, 3rd December, 1897; 6 years. (Filed 8th July, 1897.)

Claim.—1st. In a window lifter and lock, the combination of the upper and lower sashes, a rack connected to the upper sash, a pinion shaft journaled in the bearings connected to the lower sash, a pinion wheel mounted on the pinion shaft meshing with the rack of the upper sash, and means for causing the revolution of the pinion shaft, substantially as specified. 2nd. In a window lifter and lock, the combination of the upper and lower sashes, a rack connected to the upper sash, a pinion shaft journaled in the bearings connected to the lower sash, a pinion wheel mounted on the pinion shaft meshing with the rack of the upper sash, means for causing the revolution of the pinion wheel, and a spring-actuated bolt to engage the teeth of the pinion wheel and prevent its revolution, and lock together the upper and lower sashes in their adjusted position, substantially as specified. 3rd. In a window lifter and lock, the combination of the upper and lower sashes, a rack or racks connected to the upper sash, a pinion shaft mounted in suitable bearings on the top of the lower sash, a pinion wheel or pinion wheels carried by the pinion shaft meshing with the rack or racks carried by the upper sash, a bevel gear wheel mounted on the pinion shaft, a crank shaft, a bevel gear wheel mounted on the crank shaft meshing with the bevel gear wheel on the pinion shaft, and a crank mounted on the crank shaft to impart motion to the window lifter, substantially as specified. 4th. In a window lifter and lock, the combination of the upper and lower sashes, a rack or racks connected to the upper sash, a pinion shaft mounted in suitable bearings on the top of the lower sash, a pinion wheel or pinion wheels carried by the pinion shaft meshing with the rack or racks carried by the upper sash, a bevel gear wheel mounted on the pinion shaft, a crank shaft, a bevel gear wheel mounted on the crank shaft meshing with the bevel gear wheel on the pinion shaft, a crank mounted on the crank shaft to impart motion to the window lifter, a spring-actuated bolt or bolts connected to the top of the lower sash, adapted to engage with the teeth of the pinion wheel or pinion wheels, when it is desired to lock the window sashes in their adjusted position, and a stop or stops to hold the bolt or bolts out of engagement with the pinion wheel or pinion wheels, when it is desired to move the window sashes, substantially as specified.

No. 58,272. Mining Machine. (Machine à miner.)

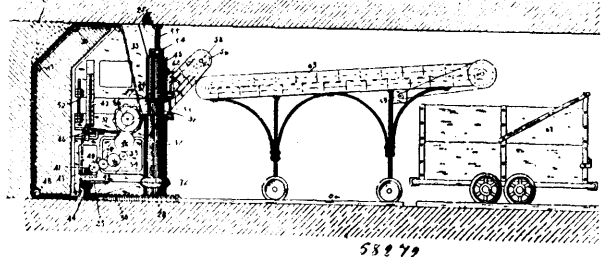

George Francis Myers, Boston, Massachusetts, U.S.A., 3rd December, 1897; 6 years. (Filed 10th May, 1897.)

Claim.—1st. A mining machine having cutters whose trajectory or path of movement in the drift is simultaneously along the top, bottom and rear side of the section to be removed, substantially as described. 2nd. A mining machine having cutters whose trajectory or path of movement in the drift is simultaneously along the top, bottom and rear side of the section to be removed, and transversely across the face of the drift, substantially as described. 3rd. A mining machine having cutters whose trajectory or path of movement in the drift is simultaneously along the top, bottom and rear side of the section to be removed, said cutters being swung as a whole upon a pivotal support, substantially as described. 4th. A mining machine having cutters whose trajectory or path of movement in the drift is simultaneously along the top, bottom and rear side of the section to be removed, said cutters being swung as a whole upon a pivotal support and having an unobstructed sweep through an arc of more than 180 degrees, substantially as described. 5th. A mining machine having cutters whose trajectory or path of movement in the drift is simultaneously along the top, bottom and rear side of the section to be removed, said cutters being swung as a whole upon a pivotal support, and comprising sprocket chains having edge cutting teeth, and supporting sprocket wheels having projecting cutters, substantially as described. 6th. A mining machine, comprising an upright frame, a column upon which said frame is mounted, a motor for swinging the frame about the column as a centre, vertically-disposed sprocket chains having edge teeth, and sprocket wheels mounted in the frame and having projecting cutters, substantially as described. 7th. In a mining machine, the combination with movable frame, of sprocket wheels journaled therein, cutter chains mounted upon the sprocket wheels, and guides extending beyond each edge of the frame at the front and back thereof so as to support the chains between adjacent sprocket wheels, substantially as described. 8th. In a mining machine, two cutter chains located side by side, and having edge teeth adapted to cut to the right and left respectively, in combination with a supporting frame for said chains, and a motor for moving said frame alternately in opposite directions, substantially as described. 9th. In a mining machine, the combination with a cutter of a conveyor or loader, and a swinging frame upon which both the cutter and conveyor are mounted, so as to preserve a constant relationship to each other during the operation of the machine, substantially as described. 10th. In a mining machine, the combination with two cutters arranged side by side and adapted to cut to the right and left respectively, of two conveyers or loaders located respectively beneath said cutters, and a swinging frame upon which the said cutters and conveyers are mounted, substantially as described. 11th. In a mining machine, the combination with a cutter, a conveyor or loader, a swinging frame upon which the cutter and conveyor are mounted, an auxiliary conveyor and a trackway upon which said auxiliary conveyor can be moved forwardly or rearwardly to accommodate itself to the varying location of the primary conveyor, substantially as described.

No. 58,273. Window Sash. (Chassis de fenêtre.)

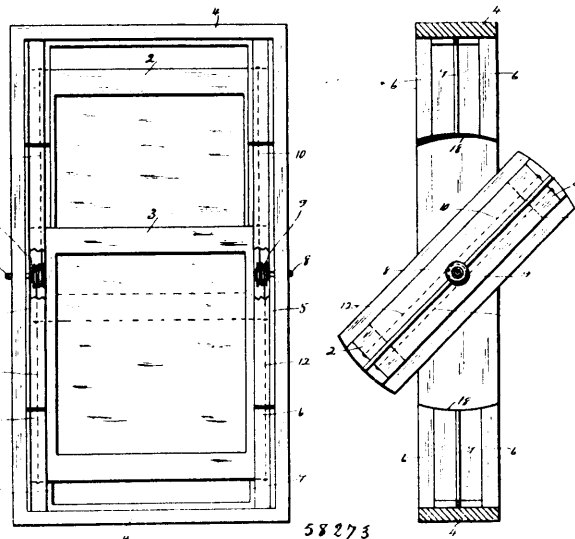

Ernest Duval, Hamilton, Ontario, Canada, 4th December, 1897; 6 years. (Filed 18th November, 1897.)

Claim.—1st. A window sash of the character described, consisting of an outer casing, having inner pivots projecting from the sides thereof and in horizontal line, double grooved pulleys to revolve on said pivots, upper and lower sash having inner recessed edges to pass and allow freedom to said pulleys, chains, or cables, to engage with said pulleys, the ends to fasten to the ends of the sash for supporting and balancing the same, and side stops and intermediate guides for the sash, as described. 2nd. A window sash, consisting

of an outer casing, and an inner side casing, pivotal centres projecting from the inner sides thereof and in horizontal line, grooved pulleys on said pivots, sash in said casing having inner recessed side edges to pass said pulleys, chains over said pulleys, with ends attached to the ends of the sash, and vertical side stops and intermediate guides for the sash to operate therein as described. 3rd. In an adjustable and swinging window sash, a sash having vertically recessed side edges for movement over grooved pulleys pivoted to the inner sides of an outer frame or casing, an inner side casing between said pulleys and the sides of said outer frame or casing, chains, the ends of which are attached to the ends of said sash, and over said pulley to operate together and in conjunction therewith, side stops and intermediate guide strips for the sash, said sash capable of swivel movement together with its parts as specified and set forth, on said side pivots, the segmental lines 18 and 18, being the divisional line of the central swivel, and the upper and lower rigid parts, as described.

No. 58,274. Wrench. (Clé à écrou.)

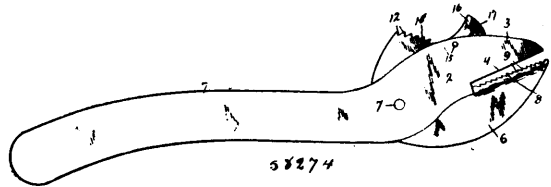

William Edward Pugsley, Nebraska, U.S.A., 4th December, 1897; 6 years. (Filed 11th November, 1897.)

Claim.—1st. An improved wrench comprising the handle 1, provided with the integral slotted head 2, and the inclined face-jaw 3, provided with the recess 19, in combination with the movable jaw 8, fulcrumed in the slotted head and provided with the curved serrated face 10, the pivoted pawl 14, having an inwardly projecting lug 17, and the spiral spring 18, seated in the recess 19, in said jaw 3, substantially as shown and described.

No. 58,275. Letter Box. (Boîte à lettres.)

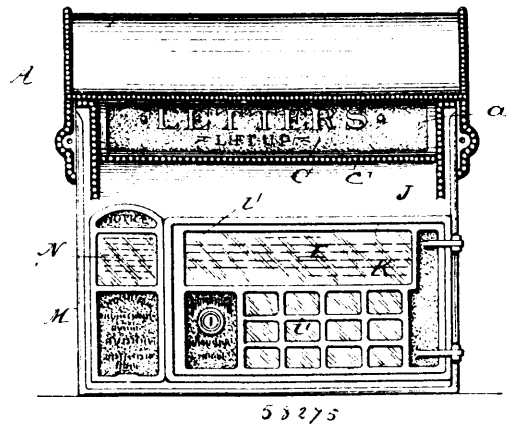

Frederick Gaston Gasehlin, San Francisco, California, U.S.A., 4th December, 1897; 6 years. (Filed 15th November, 1897.)

Claim.—1st. A letter or other receiving box, comprising a casing or box having a receiving-opening and a ledge *a*¹, a curved front guard-plate swinging within the box and adapted to successively expose and cover said opening, a receiver centrally pivoted within the box, connections between said guard-plate and the rear end of the receiver, adapted as the former uncovers the receiving-opening of the box, to bring the receiver into position so that its open end will align with said opening, and as the guard-plate covers said opening to turn the receiver so that its contents may be discharged, and a means carried by the receiver adapted to temporarily cover the receive-opening of the box preceding the alignment of said open front therewith. 2nd. A letter or other receiving box, comprising a casing or box having a receiving-opening, a tilting receiver pivoted within the box and having an open front adapted to be brought into alignment with the receiving-opening of the box, a swinging guard-plate adapted to cover and to uncover said opening successively, a curved flange on the front end of the receiver adapted to temporarily cover the box-opening preceding the alignment of the open front of said receiver therewith, and connections between said guard-plate and the tilting receiver adapted as the former uncovers the receiving-opening of the box to bring the latter up to position to cause its open front to align with said opening, and as

the front guard-plate covers said opening to turn the receiver downwardly within the box to discharge its contents therein, said connections consisting of levers pivoted in the box at points between their ends, links connecting the rear ends of said levers with the receiver, and links connecting the forward ends of said levers with the front guard-plate. 3rd. In a letter or other receiving box, the combination of a box having a receiving-opening, a tilting receiver pivoted within said box and having an open front adapted to be brought into alignment with the opening of said box, said receiver having also a guard-flange at its open front adapted to temporarily cover the opening of the box preceding the alignment of the front of the receiver therewith, a front guard-plate adapted to alternately expose and to cover said opening, said guard-plate having arms extending into the box and swinging from the same pivotal centre as that of the receiver, and connections between the front guard-plate and the receiver adapted as the former uncovers the receiving-opening of the box to bring the latter up to position to cause its open front to align with said opening, and as the front guard-plate descends to cover said opening to turn the receiver downwardly within the box to discharge its contents therein. 4th. In a letter or other receiving box, the combination of a box having a receiving-opening, a tilting receiver pivoted within said box, and having an open front adapted to be brought into alignment with the opening of said box, a front guard-plate adapted to alternately expose and to cover said opening, said guard-plate having arms extending into the box and swinging from the same pivotal centre as that of the receiver, and connections between the front guard-plate and the receiver adapted as the former uncovers the receiving-opening of the box to bring the latter up to position to cause its open front to align with said opening, and as the front guard-plate descends to cover said opening, to turn the receiver downwardly within the box to discharge its contents therein, said connections consisting of levers pivoted in the box at points between their ends, links connecting the rear ends of said levers with the receiver at points in rear of its centre of movement, and links connecting the forward ends of said levers with the said arms of the front guard-plate. 5th. In a letter or other receiving box, the combination of a box having a receiving-opening, a tilting receiver mounted within said box and having an open front adapted to be brought into alignment with the receiving-opening, a front guard-plate swinging within the box and adapted to successively expose and cover said opening, connections between the front guard-plate and the receiver whereby they work reciprocally as described, and the guard-flange on the receiver adapted to temporarily cover the receiving-opening of the box preceding the alignment of the open front of the receiver therewith. 6th. In a letter or other receiving box, the combination of a box having a receiving-opening, a tilting receiver mounted within said box and having an open front adapted to be brought into alignment with the receiving opening, a front guard-plate swinging within the box and adapted to successively expose and cover said opening, connections between the front guard-plate and the receiver, whereby they work reciprocally as described, and a guard-plate secured to the interior of the box in the forward side thereof and in close proximity to the path of travel of the receiver, the lower edge of said guard-plate being provided with arrow-shaped serrations. 7th. In a letter or other receiving box, the combination of a box having a receiver-opening, of an enlargement cast upon the ends thereof, grooved pins around which the enlargement is formed, the pins projecting into the box, a tilting receiver journaled upon said pins and having an open front adapted to be brought into alignment with the receiving-opening, a front guard-plate also journaled upon the pins swinging within the box and adapted to successively expose and cover said opening, and connections between the front guard-plate and the receiver whereby they work reciprocally. 8th. In a letter or other receiving box, in combination with a tilting receiver and front guard-plate as described, a door, a depression in front of the box communicating with the opening closed by the door and a plate having an opening secured over the depression, forming a receptacle for messages.

No. 58,276. Information Card. (Carte de renseignement.)

Henry Parker Stamford, Grand View on Hudson, New York, U.S.A., 4th December, 1897; 6 years. (Filed 12th July, 1897.)

Claim.—1st. A series of information cards, provided with similar distinguishing extensions or tabs corresponding in position or arrangement for cards of the same group, whereby when the cards are placed in a pack or drawer the distinguishing extensions or tabs on certain of the cards recording the same kind or class of information will be in alignment with each other, and out of alignment with the distinguishing extensions or tabs of other groups, substantially as described. 2nd. A series of information cards, provided with openings arranged in a predetermined order, the cards designed for recording the same kind or class of information having their openings corresponding in position or arrangement, whereby when the cards are placed in a pack the openings in certain of the cards will be in alignment with each other, as and for the purpose set forth. 3rd. A pack of information cards provided with openings arranged in a predetermined order, and a lifting pin adapted to be passed through openings in sundry of the cards, whereby certain of the cards may be raised by the pin and certain of the cards will remain stationary, as and for the purpose specified. 4th. A pack of information cards provided with openings arranged in a predeter-

mined order, a lifting pin adapted to be passed through openings in sundry of the cards, whereby certain of the cards may be raised by

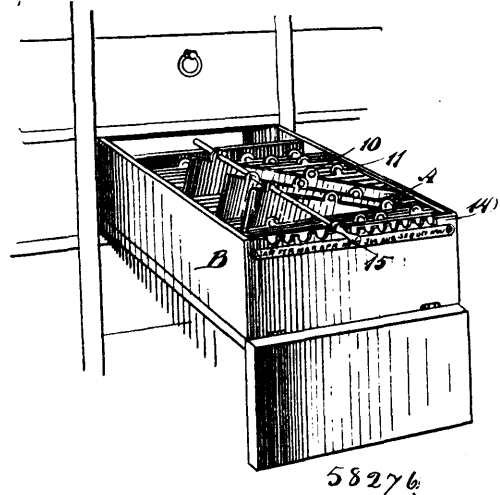

the pin, the said cards being likewise provided with registering pivot openings, and a pivot pin adapted to be passed through all of the pivot openings in the pack of cards, substantially as described. 5th. A pack of information cards, the said cards being provided with extensions from their margins and openings in said marginal projections, the cards being in series, alphabetically or numerically arranged, or otherwise classified, all of the projections of one series being in alignment, and out of alignment with the projections of a second or other series, as and for the purpose set forth. 6th. The combination, with a box or drawer having openings therein, of cards arranged in series, alphabetically, numerically or otherwise, the said cards being provided with openings of different lengths arranged in predetermined order and registering with the openings in the box, and a lifting pin adapted to be passed through the box openings and into sundry of the openings in the cards, the cards being so arranged that the openings in the cards of a certain series may be entered by a pin and the said cards elevated without disturbing the remainder of the cards, as and for the purpose specified. 7th. The combination with a box or drawer having recesses formed therein and provided with an opening, of cards arranged in series, alphabetically, numerically or otherwise classified, the said cards being provided with openings arranged in a predetermined order and registering with the recesses in the box, a lifting pin adapted to be passed through the box recesses and into sundry of the openings in the cards, the cards being so arranged that the openings in the cards of a certain series may be entered by the lifting pin and the said cards elevated without disturbing the remainder of the cards, the said cards being likewise provided with registering pivot openings, and a pivot pin adapted to extend through the opening in the box or drawer and through the registering pivot openings in the said cards, substantially as shown and described.

No. 58,277. Nozzle. (Lance de boyau.)

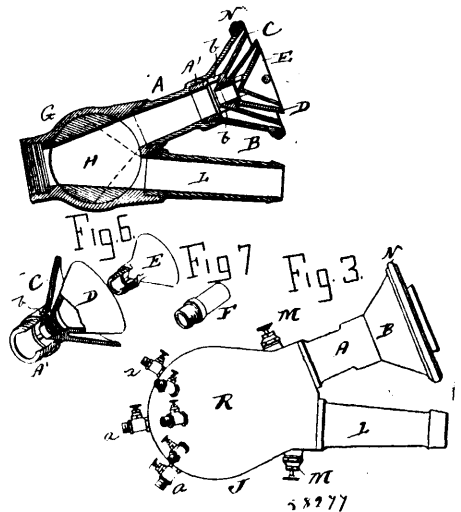

Daniel Walter Webster, Philadelphia, Pennsylvania, U.S.A., 4th December, 1897; 6 years. (Filed 26th June, 1897.)

Claim.—1st. A nozzle having a double flaring mouth provided with deflectors. 2nd. A nozzle having a double flaring mouth provided with deflectors whereby two walls of water having an air space between them may be thrown from the same nozzle. 3rd. A double flaring mouthed nozzle having a hollow flaring deflector secured in the main mouth, in combination with a second deflector or a solid pipe, either adapted to be secured into the second or outer mouth. 4th. A nozzle having a twin outlet in combination with a valve by the use of which water may be conducted into either outlet or into both at once, or entirely cut off at will. 5th. A nozzle having a cushioning ring around its outer periphery.

No. 58,278. Grinding Mechanism for Tools.

(*Mécanisme pour aiguiser les outils.*)

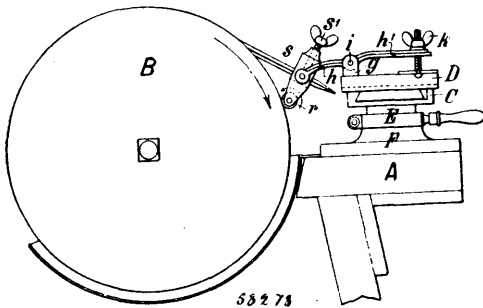

Henri Charles Bekking, Utrecht, Netherland, 4th December, 1897; 6 years. (Filed 24th June, 1897.)

Claim.—1st. A tool-grinding machine, consisting of the grindstone B, a base F secured to the jack A, the upper part of the said base being revoluble, a sledge C on the said base, sliding parallel to the axle of the said stone B, a sledge D sliding on the sledge C, and at right angles thereto, lugs g in which is pivoted the lever h, h', having its end h facing the stone fork, a tool holder S carried pivotally in the said forked end, a roll r carried in the lower end of the holder and adapted to abut on the said stone, a set screw S', to hold the tool, and a thumb-screw k to raise or depress the said tool-holder, substantially as set forth. 2nd. In a tool grinding machine, the combination with the base F, of the sledge C sliding thereon, the lever X operating the said sledge C, and the sledge D sliding on, and at right angles to the said sledge C, a lever y operating the said sledge D, substantially as set forth. 3rd. In a tool-grinding machine the combination with a grindstone, of a tool holder S pivoted in the forked arm, of a pivoted lever, a roller abutting on the said stone carried in the lower end of the said tool holder, the lever h, h' carrying the said tool holder, and a thumb-screw k to adjust the said lever, substantially as set forth.

No. 58,279. Feeder for Printing Presses.

(*Alimentateur pour presses à imprimer.*)

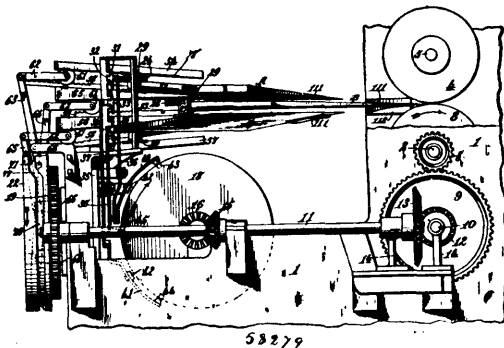

Judah T. Robertson, New York, State of New York, U.S.A., 4th December, 1897; 6 years. (Filed 23rd April, 1897.)

Claim.—1st. In a feeding device, the combination of a feeder adapted to move transversely across the path of the line of feed and to reciprocate into and away from the delivery position, said movements being in substantially the same plane, substantially as shown and described. 2nd. In a feeding device, the combination of a series of independently movable feeders adapted to move transversely across the path of the line of feed and to reciprocate into and away from the delivery position, substantially as shown and described. 3rd. In a feeding device, the combination of a series of independently movable feeders adapted to vibrate transversely across the path of the line of feed and to reciprocate into and away from the delivery position, substantially as shown and described.

4th. In a feeding device, the combination of a series of independently movable feeders adapted to move transversely across the path of the line of feed and to reciprocate into and away from the delivery position, and means whereby but one of these movements at a time is permitted to each feeder, substantially as shown and described. 5th. A printing press provided with a series of feeder boards adapted to move transversely across the path of the line of feed to the press and to reciprocate into and away from the delivery position, substantially as shown and described. 6th. A printing press provided with a series of feeder boards adapted to vibrate across the path of the line of feed to the press and to reciprocate into and away from the delivery position, substantially as shown and described. 7th. In a printing press provided with a series of feeder boards adapted to have an independent movement transversely across the path of the line of feed to the press, and to reciprocate into and away from the delivery position, substantially as shown and described. 8th. A printing press provided with a series of feeder boards adapted to have an independent movement transversely across the path of the line of feed to the press, and to reciprocate independently into and away from the delivery position, substantially as shown and described. 9th. A printing press provided with a series of feeder boards adapted to move transversely across the path of the line of feed to the press and to reciprocate into and away from the delivery position, said movements being in substantially the same plane, and means whereby but one of these movements at a time is permitted to each feeder, substantially as shown and described. 10th. In a printing press, the combination of a series of vibrating and reciprocating feeder boards having their bearings mounted one above the other, and means for presenting the front ends of said feeder boards successively to a single delivery point, substantially as shown and described. 11th. In a printing press, the combination with a series of feeders adapted to deliver successively to said press, of cam wheels adapted to impart to said feeders a transverse movement across the path of the line of feed to the press, and a reciprocating movement into and away from the delivery position, substantially as shown and described. 12th. In a feeding device, the combination of a feeder adapted to move transversely across the path of the line of feed and to reciprocate into and away from the delivery position, said movements being in substantially the same plane, and means whereby but one of these movements at a time is permitted to said feeder, substantially as shown and described. 13th. In a feeding device, the combination of a feeder adapted to move transversely across the path of the line of feed and to reciprocate into and away from the delivery position, said movements being in substantially the same plane, and means whereby the same, while in its reciprocating movement, is automatically locked against its transverse movement, substantially as shown and described. 14th. In a feeding device, the combination of a feeder adapted to move transversely across the path of the line of feed and to reciprocate into and away from the delivery position, said movements being in substantially the same plane, and means whereby the same, while in its transverse movement, is automatically locked against its reciprocating movement, substantially as shown and described. 15th. In a feeder board for printing presses, the combination of the body of the board having a series of longitudinal slots thereon, a cross-bar extending transversely of the board beneath the body of the same and adjustable longitudinally of the same, transverse shafts pivoted in bearings on said cross-bar beneath said slots, nuts carried by said shafts and adjustable longitudinally thereon, pin points mounted in said nuts and adapted to normally project through the slots in the body of the board, springs engaged with said shafts and their bearings to exert a normal tension on the shafts in one direction, and stops on said shafts for limiting the rotation of the same in that direction, substantially as shown and described. 16th. In a feeder board for printing presses, the combination of adjustable pin points projecting through the body thereof, and adjustable resilient fingers mounted on the sides of the board and having apertures adapted to register with said pin points and adapted by manual pressure to force the paper, when passed there-between, into engagement with said pin points and to spring back to their normal position when pressure is removed therefrom, substantially as shown and described. 17th. In a feeder board for printing presses, the combination of adjustable pin points projecting through the body thereof, and fingers mounted on longitudinally adjustable bearings on the sides of the board and centrally slotted longitudinally to provide adjustable connections with their said bearings, the said fingers formed at their outer ends of transparent or semi-transparent material having apertures therein adapted to register with the pin points, substantially as shown and described.

No. 58,280. Feeder for Printing Presses.

(*Alimentateur pour presses à imprimer.*)

Judah T. Robertson, New York, State of New York, U.S.A., 4th December, 1897; 6 years. (Filed 23rd April, 1897.)

Claim.—1st. In a feeding device, the combination of a series of independently movable feeders adapted to be successively presented in delivery position at the same point, substantially as shown and described. 2nd. In a feeding device, the combination of a series of independently movable feeders adapted to move transversely across the path of the line of feed and to successively stop in delivery position, substantially as shown and described. 3rd. In a feed-

ing device, the combination of a series of independently movable feeders adapted to successively deliver to the same point, each

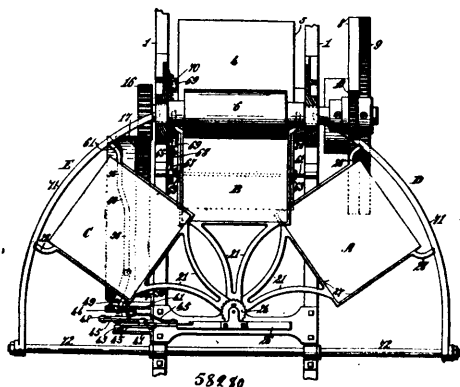

feeder adapted to remain at rest in position to receive during the delivery of the other feeders, substantially as shown and described. 4th. A printing press provided with independently movable multiple feeder boards adapted to be successively presented in delivery position at the same point, substantially as shown and described. 5th. A printing press provided with a series of independently movable feeders adapted to be successively presented to the press at the same point in position to deliver, substantially as shown and described. 6th. A printing press provided with a series of independently movable feeders adapted to be successively presented to the press in position to deliver, and means for accurately registering said feeders independently when in said position to deliver, substantially as shown and described. 7th. A printing press provided with a series of independently movable feeders adapted to move transversely across the path of the line of feed to the press and to successively stop in position to deliver to said press, substantially as shown and described. 8th. In a printing press, the combination of a printing couple, a series of independently movable feeder boards, means for successively presenting the same to substantially the delivery position, and means for positioning the same independently to the proper delivery plane, substantially as shown and described. 9th. A printing press provided with a series of independently movable feeders adapted to move transversely across the path of the line of feed to the press and to successively stop in position to deliver to said press, and means for successively positioning said feeders to the proper delivery plane, substantially as shown and described. 10th. A printing press provided with a series of independently movable feeders adapted to move transversely in the arc of a circle across the path of the line of feed to the press and to successively stop in position to deliver to said press, substantially as shown and described. 11th. A printing press provided with a series of independently movable feeders adapted to move transversely in the arc of a circle across the path of the line of feed to the press and to successively stop in position to deliver to said press, and means for successively adjusting said feeders to the proper delivery plane, substantially as shown and described. 12th. A printing press provided with a series of independently movable feeders adapted to move transversely in the arc of a circle across the path of the line of feed to the press and to successively stop in position to deliver to said press, means for successively positioning said feeders to the proper delivery plane, and means for accurately registering said feeders when in position to deliver, substantially as shown and described. 13th. A printing press provided with a series of independently movable feeder boards adapted to vibrate transversely in the arc of a circle across the path of the line of feed to the press and to successively stop in position to deliver to said press, substantially as shown and described. 14th. A printing press provided with a series of independently movable feeders adapted to successively deliver to said press at the same point, each feeder adapted to remain at rest in laying on position during the delivery of the other feeders, substantially as shown and described. 15th. A printing press provided with a series of feeder boards adapted to vibrate transversely in the arc of a circle across the path of the line of feed to the press and to successively stop in position to deliver to said press, each feeder board adapted to alternately remain at rest on each side of the delivery position during the delivery of the other feeder boards, substantially as shown and described. 16th. In a printing press, the combination of a printing couple, a series of feeder boards adapted to vibrate transversely in the arc of a circle across the path of the line of feed to the press and to successively stop in position to deliver to said press, a series of racks for operating said feeder boards, and a cam wheel geared to the plate cylinder and adapted to operate the racks and feeder boards through intermediate mechanism, substantially as shown and described.

No. 58,281. Boat. (Bateau.)

Moses H. Davidson, Louisville, Kentucky, U.S.A., 4th December, 1897; 6 years. (Filed 20th April, 1897.)

Claim.—A vessel consisting of a hull provided with a plurality of rotatable hollow cylinders supported upon the bottom portion of the

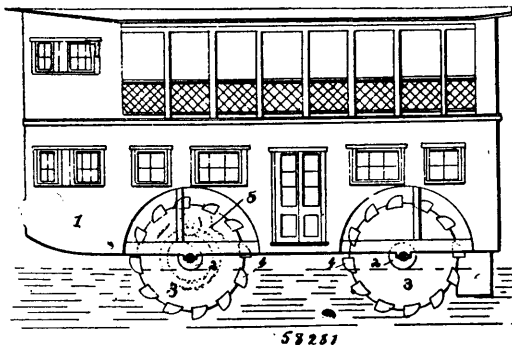

hull and projecting below the same, a motor within said hull geared to each of said rotatable cylinders for turning the same, radially extending propelling blades mounted upon the periphery of said cylinders and extending longitudinally across the same, and plates at the ends of said blades, each of said cylinders being provided with a concentric cylinder having water-tight connection with the side of the cylinder, and intersecting transverse and longitudinal radial partitions extending between the outer shell and inner shell of said cylinder and between the sides of the same and forming a plurality of water-tight compartments.

No. 58,282. Exhaust-Utilizer for Engines.

(Appareil pour utiliser la vapeur d'échappement.)

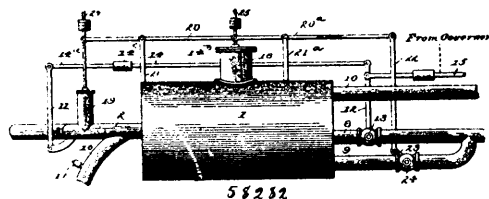

Patrick Francis Haley, Philadelphia, Pennsylvania, U.S.A., 4th December, 1897; 6 years. (Filed 18th November, 1897.)

Claim.—1st. In an apparatus of the class described, the combination of a reservoir, a main supply pipe provided with a reducing bushing, a check valve and a reciprocating cut-off valve, a discharge pipe, an escape pipe having a valve, levers connected with said valve and reciprocating cut-off, and an adjustable rod connecting said levers, substantially as shown and described. 2nd. In an apparatus of the class described, the combination of a reservoir, a main supply pipe, a conical reducing bushing in said pipe, a conical reciprocating cut-off valve connected therewith, a check valve between the cut-off valve and reservoir, an exhaust pipe adapted to carry off the pressure in the supply pipe when said check valve is closed, a discharge pipe, an escape pipe having a valve, levers connected with said valve and the reciprocating cut-off, and an adjustable rod connecting said levers, substantially as shown and described. 3rd. In an apparatus of the class described, the combination of a reservoir, a main supply pipe having a check valve adapted to close when the pressure in the reservoir exceeds that in the main pipe, a discharge pipe, an escape pipe provided with a valve, cylinders in communication with the supply pipe and reservoir, a plunger in each cylinder, a tilting rod connecting the rods of said plungers, and a lever connecting the tilting rod and escape pipe valve, substantially as described. 4th. In an apparatus of the class described, the combination of a reservoir, a main supply pipe provided with a reducing bushing, a check valve and a reciprocating cut-off valve, a discharge pipe, an escape pipe provided with a valve, cylinders in communication with the supply pipe and reservoir, a plunger in each cylinder, a tilting rod connecting the rods of said plungers, and a lever connecting the tilting rod and escape pipe valve, substantially as described.

No. 58,283. Folding Cot. (Lit pliant.)

James Henry Martindale and Abram Myers Kinsel, both of Dallas, Texas, U.S.A., 4th December, 1897; 6 years. (Filed 19th November, 1897.)

Claim.—1st. A folding cot comprising end bars, a flexible bottom connecting the same, removable side bars formed in connected sections of about the length of the respective end bars, corner irons rigidly secured to the end bars and having sockets into which the ends of the side bars are removably slipped, and provided with vertically disposed leg sockets open at their lower ends and inner sides, and legs pivoted in said sockets to fold upwardly against the under sides of the respective end bars, substantially as set forth. 2nd. A folding cot comprising end bars, a flexible bottom connect-

ing the same, removable side bars formed in hinged sections of about the length of the respective end bars, corner irons having

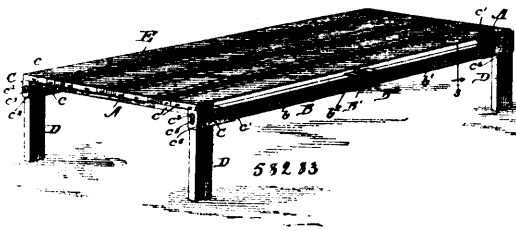

horizontal transverse upper sockets in which the ends of the end bars are rigidly secured, horizontal longitudinal sockets into which the ends of the side bars are removably slipped and vertically disposed leg sockets beneath the end bar sockets, and open at their lower ends and inner sides, and the legs having a pivotal sliding connection with the leg sockets and provided with devices for locking them to the sockets against folding, said legs being adapted, when the locking devices are disconnected, to fold up against the lower sides of the respective end bars, substantially as set forth. 3rd. A folding cot comprising end bars, a flexible bottom connecting the same, removable side bars each formed in two sections, sockets on the abutting ends of the sections and hinged together at their adjacent sides, a latch on one socket and a catch on the other socket engaged thereby, corner irons having sockets *c* receiving the ends of the end bars and rigidly secured thereto, sockets *c*¹ removably receiving the ends of the side bars, and vertically disposed leg sockets upon their lower ends and inner sides and provided with slots *c*², and notches *c*³, and the legs provided with pins or studs engaging said notches, substantially as set forth. 4th. In a folding cot, the corner iron *C* formed with three integral sockets *c*, *c*¹, *c*², for the end bar, the side bar and the leg respectively, the sockets *c*, *c*¹, being in horizontal planes and at right angles to each other, and the leg socket *c*² lying vertically beneath the juncture of the other two sockets and open at its lower end and inner side, substantially as set forth.

No. 58,284. Artificial Fuel. (*Combustible artificiel.*)

John Wood Leadbeater, Banstead Grove, Roundhay Road, Leeds, England, 4th December, 1897; 6 years. (Filed 19th November, 1897.)

Claim.—1st. The manufacture and production of a combustible compound, consisting of, or containing petroleum, stearine, resin, lime and sawdust, substantially as hereinbefore described. 2nd. The manufacture and production of a combustible compound by preparing a mixture of petroleum, resin, lime and sawdust in a state somewhat approaching that of a fluid and mixing and setting it with other matter to be consumed, substantially as hereinbefore described. 3rd. The mode of preparing the compound, as set forth, a minimum amount of heat being used in the preparation, with a special view of retaining volatile matter. 4th. The manufacture and production of briquettes or blocks of fuel from the waste products or other carbonaceous matter enriched with a mixture of petroleum, stearine, resin, lime and sawdust, substantially as hereinbefore described. 5th. The manufacture and production of briquettes or blocks of fuel by adding the aforesaid petroleum compound in a granulated or divided condition to the matter forming the other components of the briquettes and agglomerating and pressing the mixture, substantially as hereinbefore described. 6th. The manufacture and production of briquettes or blocks of fuel by adding the aforesaid petroleum compound in a state somewhat approaching that of a fluid to the matter forming the other compounds of the briquettes during, or just before agglomerating, and then pressing the mixture, substantially as hereinbefore described. 7th. The manufacture and production of briquettes or blocks of fuel by mixing with the matter forming the main bulk of the briquettes, the aforesaid petroleum compound, and pitch, starch, or other agglutinant, and then subjecting the mixture to pressure, substantially as hereinbefore described.

No. 58,285. Grip for Cable and Rope Railways.

(*Grippe pour chemins de fer à câbles et cordes.*)

Adolf Bleichert, Leipzig-Gohlis, Germany, 4th December, 1897; 6 years. (Filed 19th November, 1897.)

Claim.—1st. In suspended cable or rope railways, the combination with the framework of the rolling mechanism of the vehicle, of a sliding body guided by said framework and supporting the vehicle, a pivoted lever one arm of which engages with said sliding body and the other arm terminates in a gripping-jaw, a stationary gripping-jaw co-acting with the gripping-jaw of the lever, and a traction-cable adapted to be locked between said jaws. 2nd. The combination with the framework of the rolling mechanism of the

vehicle, of a sliding body guided by said framework and supporting the vehicle, a pivoted lever one arm of which engages with said

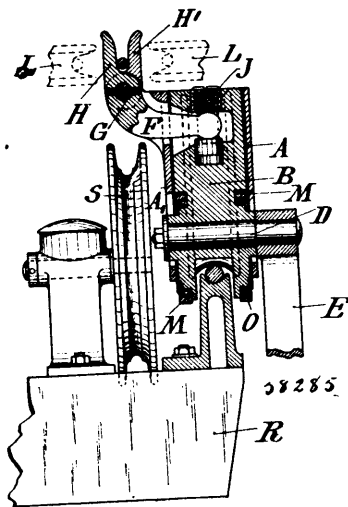

sliding body and the other arm terminates in a gripping-jaw, a stationary gripping-jaw co-acting with the gripping-jaw of the lever, a traction-cable adapted to be locked between said jaws, and means whereby the gripping-jaws may be adjusted according to the varying thicknesses of the cable. 3rd. The combination with the framework of the rolling mechanism of the vehicle, of a sliding body guided by said framework and supporting the vehicle, a pivoted lever one arm of which engages with said sliding body and the other arm terminates in a gripping-jaw, a stationary gripping-jaw co-acting with the gripping-jaw of the lever, a traction-cable adapted to be locked between said jaws, and a set-screw for adjusting the gripping-jaws. 4th. The combination with the framework of the rolling mechanism of the vehicle, of a sliding body guided by said framework and supporting the vehicle, a pivoted lever one arm of which engages with said sliding body and the other arm terminates in a gripping-jaw, a stationary gripping-jaw co-acting with the gripping-jaw of the lever, a traction-cable adapted to be locked between said jaws, and a set-screw arranged in said sliding body and having a recess to receive the arm of said lever, whereby the point of action or operation of said lever may be varied by adjusting said screw. 5th. The combination with a framework of the rolling mechanism of the vehicle, of coupling mechanism for locking the vehicle to the traction-cable, a sliding body for carrying the same, the gripping appliances of said coupling mechanism located above the rolling frame, a rail for supporting the rolling frame, and rails for intermittently taking the weight of such sliding body. 6th. The combination with the framework of the rolling mechanism of the vehicle, of a sliding body guided by said framework and carrying at its lower end a bolt or rod from which the vehicle is suspended, a pivoted lever one arm of which engages with said sliding body and the other arm terminates in a gripping-jaw, a stationary gripping-jaw co-acting with the gripping-jaw of the lever, and a traction-cable adapted to be locked between said jaws. 7th. The combination with the framework of the rolling mechanism of the vehicle, of a sliding body guided by said framework and supporting the vehicle, rails *g*, adapted to support said sliding body, a pivoted lever one arm of which engages with said sliding body and the other arm terminates in a gripping-jaw, a stationary gripping-jaw co-acting with the gripping-jaw of the lever, a traction-cable adapted to be locked between said jaws, and appliances connected to said sliding body at its lower end and serving to raise or lower said body by means of rails *g*, as the vehicle enters or departs from the station, thus automatically throwing the gripping-jaws into or out of engagement with the traction-cable. 8th. The combination with the framework of the rolling mechanism of a vehicle, of a sliding body guided by said framework and supporting the vehicle, a pivoted lever one arm of which engages with said sliding body and the other arm terminates in a gripping-jaw, a stationary gripping-jaw co-acting with the gripping-jaw of the lever, a traction-cable adapted to be locked between said jaws, and guiding-rings at the lower end of said sliding body, substantially as set forth. 9th. The combination with the framework of the rolling mechanism of the vehicle, of a sliding body guided by said framework and supporting the vehicle, a pivoted lever the short arm of which terminates in a jaw at that side of the frame opposite that at which the rolling mechanism travels, a stationary jaws secured to the framework in suitable relation to the jaw of said lever, a traction-cable adapted to be locked between said jaws, and rollers *u*, for supporting said cable at the free portions of the line, substantially as set forth.

No. 58,286. Door Spring. (Ressort de portes.)

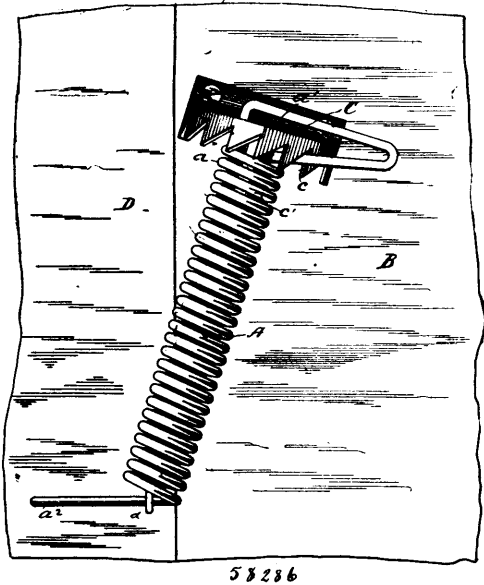

William Hargrove, Chicago, Illinois, U.S.A., 4th December, 1897; 6 years. (Filed 19th November, 1897.)

Claim.—The combination with a door and its casing, of a bracket adapted to be secured to the door and provided on its under side with ratchet teeth and a depending lug, a coil spring, the upper coils embracing said lug, and having an arm extended outwardly from the uppermost coil and bent upon itself to form a spring lever, one arm of which rests upon the upper face of the bracket, the other arm engaging the ratchet teeth, and means for securing said spring to the door casing, consisting of the arm *a*² extended outwardly from the lowermost coil thereof and having an eyelet *d*, secured in the casing, and through which said arm may be passed and held in place, substantially as shown and described.

No. 58,287. Tension Device for Grain Binders. (Appareil de tension pour lieuses.)

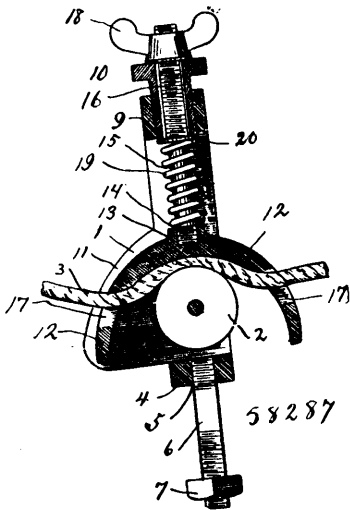

Nathaniel Lee Pratt, Blissfield, Michigan, U.S.A., 4th December, 1897; 6 years. (Filed 22nd November, 1897.)

Claim.—1st. In a tension device for grain binders, a frame, a roller journaled therein, a twine guide having a frictional surface in coincidence with the roller, and a suspension rod secured therein provided with a screw-threaded upper end, a tension spring upon the rod, a tubular externally-threaded nut run into the frame and bearing upon the upper end of the spring, a nut upon the upper end of the suspension rod, whereby the guide may be raised to allow of inserting the twine through holes formed in the ends of the twine guide and over the roller, the internal diameter of tubular nut allowing natural sway to the rod passed therethrough to allow a rocking motion of the twine-guide with respect to the roller, to compensate

for unevenness of the twine. 2nd. In a tension device for grain binders, a frame for attachment to the binder, formed with forwardly projecting wings or fenders, a roller journaled in the frame, a twine guide formed with a semicircular lower face, secured in the frame by a vertical post and a coiled spring thereon, a tubular nut screwed in the frame and bearing upon the spring, and a screw thread upon the post having a nut thereon for raising the twine guide to allow of insertion of the twine through a hole formed in each side of the guide.

No. 58,288. Fence Gate. (Barrière.)

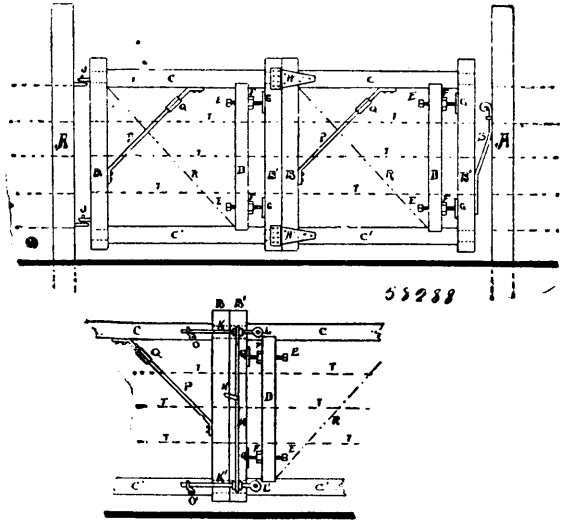

James W. Bolger, Stratford, Quebec, Canada, 4th December, 1897; 6 years. (Filed 22nd November, 1897.)

Claim.—1st. The combination of two gate frames BB¹, CC¹, BB¹, CC¹, and the bar lock KK¹, M, substantially as and for the purpose hereinbefore set forth. 2nd. The combination, with the gate frame BB¹, CC¹, of the tightening screws EE, and the backing framer D, substantially as and for the purpose hereinbefore set forth.

No. 58,289. Railway Car Running Gear. (Engrenage de chars de chemin de fer.)

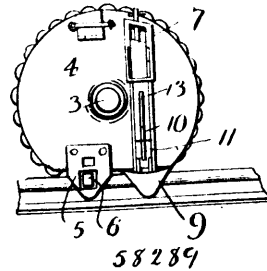

William Daniel Widders, Fairland, Cherokee Nation, Indian Territory, U.S.A., 4th December, 1897; 6 years. (Filed 24th November, 1897.)

Claim.—1st. A running gear for railroad cars, comprising axles, and wheels carried by said axles, the said wheels being flattened for a portion of their circumference and provided with annular grooves to receive a series of antifriction balls, rollers carried by the said wheels to prevent lateral movement thereof, and means arranged upon said wheels to prevent an upward movement of the axles, substantially as described. 2nd. A running gear for railroad cars, comprising axles and wheels, the said wheels being flattened for a portion of their circumference and provided with annular grooves to receive a series of antifriction balls, and guide-ways mounted upon each side of the wheels, in which guide-blocks are arranged, the said blocks being provided with grooved rollers adapted to normally engage the side edges of the rail, substantially as described. 3rd. A running gear for railroad cars, comprising axles and wheels, the said wheels being flattened and provided with annular grooves to receive a series of antifriction balls, guide-ways mounted upon each side of said wheels, slotted guide-blocks adapted to work in said guide-ways, and arms provided at their upper ends with a lip or projection and at their lower ends with a grooved roller, the said

arms being pivotally connected to said guide-blocks, substantially as described. 4th. A running gear for railroad cars, comprising axles and wheels, the said wheels being flattened for a portion of their circumference and provided with annular grooves to receive a series of antifriction balls, the said grooves having an enlargement to admit the balls into the grooves, and a cover to close said enlargement, guide-ways mounted on each side of said wheels and provided with slots, guide-blocks adapted to work in said guide-ways, the lower ends of which are provided with hoods, arms pivotally mounted in said guide-blocks, the lower ends of the said arms carrying a grooved roller and the other ends being provided with a lip or projection, and a spring adapted to engage behind the said lips or projections, substantially in the manner and for the purpose described.

No. 58,290. Artificial Limb. (Membre artificiel.)

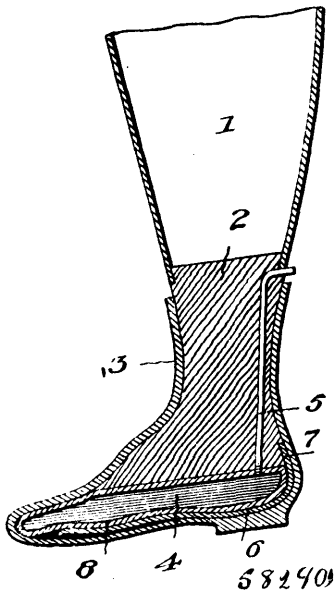

William Roberts, Plymouth, Pennsylvania, U.S.A., 6th December, 1897; 6 years. (Filed 22nd May, 1897.)

Claim.—An artificial foot, comprising the socket 1, the block 2 secured in the lower end thereof, in combination with the pneumatic sole 4, provided with an inflating tube 5 extending vertically upward through said block 2, and a leaf spring 6 having its vertical arm 7 permanently fixed to said block, and its integral horizontal arm 8 extending around the heel portion of the block and pneumatic sole and underneath and parallel with said sole, substantially as shown and described.

No. 58,291. Rail Fastening. (Attache de rails.)

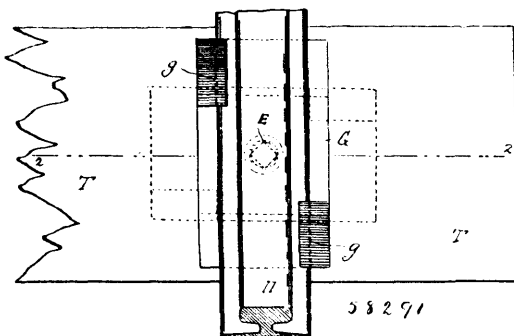

Wallace C. Kemble, Trenton, New Jersey, U.S.A., 6th December, 1897; 6 years. (Filed 24th November, 1897.)

Claim.—1st. A rail fastening, comprising a plate resting upon the tie and having a pivot attached thereto and extending downward through the tie, said pivot having teeth upon opposite sides of its lower end, upwardly-projecting lugs upon said plate adapted to engage the rail-base when the plate is revolved, and spring held slides beneath the tie adapted to engage the teeth of said pivot when the plate is turned to hold the rail-base, substantially as described. 2nd. A rail-fastening, comprising a plate resting upon the tie, and having a pivot attached thereto and extending down-

ward through the tie, said pivot having teeth upon opposite sides of its lower ends, upwardly-projecting lugs upon said plate adapted to engage the rail-base when the plate is revolved, a plate secured beneath the tie, having a hole for said pivot, and spring held slides mounted upon said plate, and adapted to engage the pivot, substantially as described. 3rd. A rail-fastening, comprising a plate resting upon the tie, and having upwardly-projecting lugs to engage and release the rail base when rotated relatively thereto, a pivot-bar fixed thereto and extending through the tie, said bar having its lower end bevelled or formed as a wedge, the edge thereof extending across the direction of the rail, and having the sides at right angles to these bevels notched to form ratchet-teeth, a plate beneath the tie having a hole for said pivot bar, and spring-held slides adapted to project across said opening and engage the teeth upon the bar, substantially as specified.

No. 58,292. Art of Producing Inexplosive Acetylene Gas. (Art ou procédé pour la production de gaz acetyline inexplosif.)

Christian E. Bichel, Hamburg, Germany, and Engelbert Schulte, Libau, Russia, 6th December, 1897; 6 years. (Filed 21st January, 1896.)

Claim.—1st. The herein described improvement in the art or process of producing inexplosive acetylene gas, consisting in adding to the acetylene or to the mixture of acetylene and air an inert or inactive gas or one substantially free from oxygen, substantially as set forth. 2nd. An inexplosive combustible gas composed of a mixture of acetylene or acetylene and air, and an inert or inactive gas or one substantially free from oxygen in or about the proportions set forth.

No. 58,293. Method of Making Gas.

(Méthode de fabriquer du gaz.)

Louis G. Harris, Toronto, Ontario, Canada, 6th December, 1897; 6 years. (Filed 26th July, 1897.)

Claim.—1st. The herein described process of manufacturing gas from garbage or other refuse, which consists in mixing with the same a liquid hydrocarbon and then distilling the mixture, substantially as set forth. 2nd. The herein described method of manufacturing gas from garbage or other refuse, which consists in mixing with the same a liquid hydrocarbon, and alkali, and then distilling the mixture, substantially as set forth. 3rd. The herein described method of manufacturing gas from garbage or other refuse, which consists in mixing with the same a liquid hydrocarbon, alkali and chloride of lime and then distilling the mixture, substantially as set forth. 4th. The herein described method of manufacturing gas from garbage or other refuse, which consists in mixing with the same a liquid hydrocarbon alkali, chloride of lime, soap bark, and then distilling the same, substantially as in the proportions and for the purpose set forth.

No. 58,294. Protector for Railway Signalling and Switching Systems. (Système de protecteur de signal et aiguille de chemin de fer.)

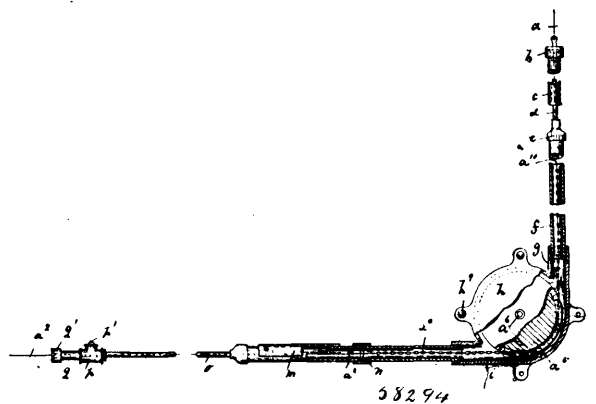

John Wrigley, Elmira, New York, U.S.A., 6th December, 1897; 6 years. (Filed 22nd November, 1897.)

Claim.—1st. The combination with wires, rods and the like, in systems of the character above described, of pipes inclosing said wires, rods, etc., and of a lubricant, such as oil, in said pipes, substantially as and for the purposes described. 2nd. The combination with wires, rods and the like, in systems of the character above described, of pipes surrounding said wires, rods, etc., a box intermediately arranged between said pipes and also inclosing its respective wire, a lid removably arranged on said box, and a lubricant, such as oil, in said pipes and box, all said parts substantially as and for the purposes described. 3rd. The combination with wires, rods, chains and pulleys in systems of the character above described, of

pipes inclosing said rods, wires, chains, etc., a substantially airtight box or receptacle, inclosing said pulleys, and intermediately arranged between said pipes and connected therewith, and a lubricant, such as oil, in said pipes and box or receptacle, all said parts substantially as and for the purposes described. 4th. The combination with wires, rods, and the like, and with chains and pulleys, in systems of the character above described, of pipes connecting said wires, rods, chains, etc., a receptacle intermediately arranged between said pipes and connected therewith and inclosing the said pulleys, a box also inserted between said pipes and connected therewith and provided with a removable lid, a lubricant, such as oil, in said pipes, receptacle and box, all said parts substantially as and for the purposes described. 5th. The combination with wires, rods and the like, in systems of the character above described, of pipes surrounding and inclosing said wires, rods, etc., a T-coupling at or near one end of said pipes and provided with a removable plug, a loose cap or cover on the other end of said pipes, a lubricant, such as oil, in said pipes and T-coupling, all said parts substantially as and for the purposes described. 6th. The combination with grooved pulleys and chains passing over the same, in systems of the character above described, of a box or receptacle inclosing said pulleys, and provided with inlets and outlets, and a lubricant, such as oil, in said box or receptacle, substantially as and for the purposes described. 7th. The combination with wires, rods and the like, in systems of the character above described, of pipes inclosing said wires, rods, etc., a lubricant, such as oil, in said pipes, and a closed pipe loosely arranged on and adapted to protect the free end of the pipes, substantially as described.

No. 58,295. Machine for Making Fish Nets.
(Machine pour la fabrication des rets.)

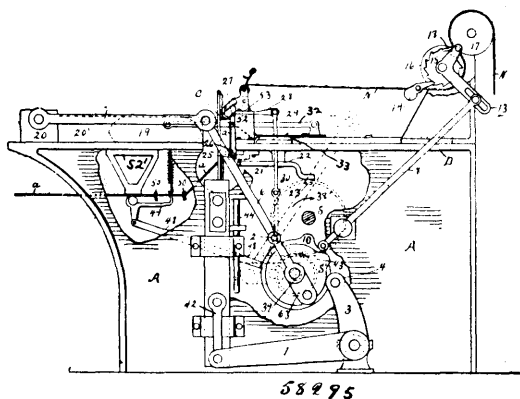

Samuel H. Roberts and Walter Scott Luther, both of Joliet, Illinois, U.S.A., 6th December, 1897; 6 years. (Filed 27th July, 1897.)

Claim.—1st. In a machine for making nets, the combination of the oscillating hooks 26, reciprocating pins 27, arranged a short distance from said hooks, cord-carriers 35 for carrying a cord around said hooks and pins to form loops in said cords, shuttles and devices for actuating them to carry a second cord back and forth through said loops, means for actuating the hooks to twist said loops, and after the return of the shuttles through said twisted loops to twist the loops back to their first position, bar F arranged to reciprocate immediately above said hooks to remove the loops therefrom, levers 33, connecting-rod 32, and cam-wheels 64 for actuating said bar F, cross-bar 49, rod 48, and cam 5 for operating bar 49, all arranged to operate substantially as and for the purpose set forth. 2nd. In a machine for making nets, the combination of the bar 56 having the cord carriers 35 attached thereto, and means for actuating the same, the oscillating hooks 26, the reciprocating pins 27, the means for operating said pins and hooks, cord removing bar F adjacent to the hooks 26, the shuttle carrier, link rods 32 and frame 33 for actuating said bar F, cross-bar 49, rod 48 and cam wheel 37 for operating bar 49, cross-bars 50, 50, and clamps 51 and 52 whereby the knot is drawn up tight, all arranged to operate substantially as and for the purpose set forth. 3rd. In a machine for making nets, the combination of a reciprocating pin, a flat, horizontally arranged oscillating hook adjacent to said pin, the cord carrier for carrying a cord around said pin and hook to form a loop, a shuttle and its carrier for carrying a second cord back and forth through said loop, means for actuating the hook to twist the loop, and after the return of the shuttle through the twisted loop to twist the loop back to its first position, the means for casting the loop from said hook, the take-up mechanism for drawing the loop up on the pin to form a knot, and the means for operating the pin, all arranged to operate, substantially as and for the purpose set forth. 4th. In a machine for making nets, the combination of the oscillating hooks 26, reciprocating pins 27 arranged a short distance from said hooks, cord carriers 35 for

carrying one of the cords *a* around said hooks, and pins to form a loop in said cord, flat shuttle 19 having a receptacle for a ball of cord having the spring tension plates 67 and adapted to carry said second cord back and forth through said loop bar F arranged to reciprocate immediately above said hooks for removing the loop therefrom and the cord and net take-up mechanism, all arranged to operate substantially as and for the purpose set forth. 5th. In a machine for making nets, the combination of the oscillating hooks, the reciprocating pins, the cord carriers for carrying one of the cords around said hooks and pins to form the loops, the flat shuttle for carrying a second cord back and forth through said loops and the means for operating said parts, all arranged to operate substantially as and for the purpose set forth. 6th. In a machine for making nets, the combination of the oscillating hooks 26, cord carriers 35, reciprocating pins 27, cord removing bar F, shuttle 19, the cord and net take-up mechanism and the means for operating said parts, all arranged to operate substantially as and for the purpose set forth. 7th. In a machine for making nets, the combination of the bar 56 having the cord carriers 35, the oscillating hooks 26, the reciprocating pins 27, the cord removing bar F for removing the loops from said hooks, the take-up mechanism for drawing up the loops on said pins, and the means for operating said parts, substantially as and for the purpose set forth. 8th. In a machine for making nets, the shuttle 19 having a receptacle for containing a ball of twine or cord adapted to be unwound from its interior, and having a pulley 68 for carrying the unwound cord, and having the spring side plates 67 for slightly engaging said cord as it passes between said plates, substantially as and for the purpose set forth. 9th. In a machine for making nets, the combination of the oscillating hooks, the reciprocating pins, the cord carriers for carrying a cord around said hooks and pins, and the means for operating said parts, all arranged to operate substantially as and for the purpose set forth. 10th. In a machine for making nets, the combination of the loop forming mechanism, the shuttle adapted to carry a flattened ball of cord in such manner as to unwind from its interior, and the mechanism for carrying said shuttle back and forth through the loops, all arranged to operate substantially as and for the purpose set forth. 11th. In a machine for making nets, the combination of a reciprocating pin, a flat horizontally arranged hook adjacent to said pin, the means for carrying a cord around said pin and hook to form a loop, a shuttle for carrying a second cord through said loop, the means for twisting said loop, and for returning the shuttle through the twisted loop, and for twisting the loop back to its first position, the means for casting the loop from said hook, the take-up mechanism for drawing the loop up on said pin to form a knot, and for withdrawing said pin from the loop and the means for operating said parts, all arranged to operate substantially as and for the purpose set forth.

No. 58,296. Tobacco Pipe. (Pipe à tabac.)

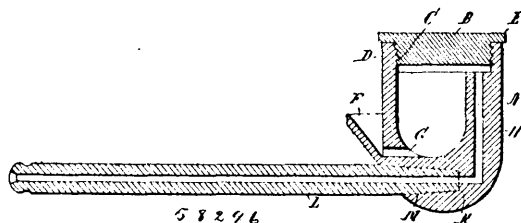

Henry Dicks Fanders, Leadville, Colorado, U.S.A., 6th December, 1897; 6 years. (Filed 5th August, 1897.)

Claim.—1st. A tobacco pipe, the bowl of which is provided with an air ingress opening or passage at the bottom thereof, said bowl of the pipe being also provided with a detachable cap or cover, and in one side thereof, with a vertical passage which opens upwardly, and the lower end of which communicates with the central bore of the stem, substantially as shown and described. 2nd. A tobacco pipe, the bowl of which is provided with a detachable cap, said bowl being also provided in one side thereof, with an air passage, which communicates with the bottom thereof, and in one of its side walls with a vertical passage which opens upwardly adjacent to the bottom of said cap, and the lower end of which is in communication with the central bore of the stem, substantially as shown and described.

No. 58,297. Sand Sprinkler for Electric Cars, etc.

(Appareil à soupoudrer le sable pour chars électriques.)

Hugh Charles Sweeney, Hamilton, Quebec, Canada, 6th December, 1897; 6 years. (Filed 22nd November, 1897.)

Claim.—1st. A valve casing attached to a car platform and located in the fore part thereof, a sand receptacle suitably located to feed said casing, and capable of detachment therefrom, said casing provided with a valve operated by the foot by means of a raised knob on the platform, the shank of said knob being connected to the outer and lower bent shank of the pivoted valve by means of a bent lever, pivoted underneath the platform, in order to open said valve, as described. 2nd. A sand sprinkling device of the character

described, consisting of a valve casing secured to a car platform, a detachable sand receptacle capable of feeding said valve casing, a

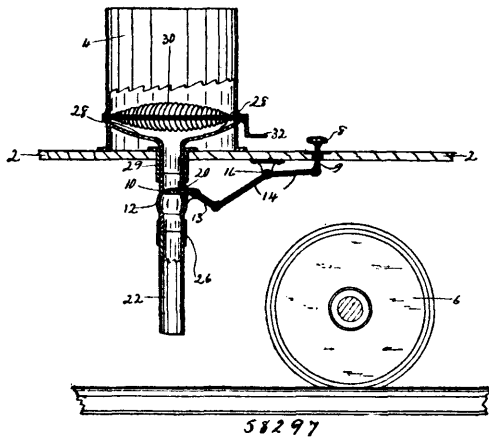

sand agitator located in the lower part of sand receptacle and having through shaft with outer crank and bowed out in the middle to conform to the concave bottom of said receptacle, a valve in said casing pivoted to the outer side thereof and capable of being lowered and opened by operating a platform knob which is connected to the outer bent shank of said valve by means of a pivoted lever, and a sand outlet tube connected to the lower part of valve casing, as described. 3rd. A sand sprinkling device for cars and other road vehicles, consisting of a valve casing having a lower sand outlet tube attached in front of the fore wheel or wheels thereof, a sand receptacle having concaved base, with shank, for attachment to, and detachment from said valve casing, by means of rigid socket, a pressure foot knob, pivotal arm of a valve located in valve casing, and mechanism connecting said foot knob to pivotal arm of said valve to open the same, as described.

No. 58,298. Snap Hook. (Crochet à ressort.)

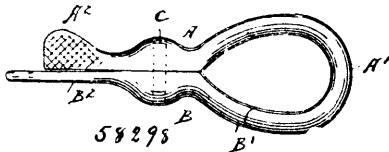

William H. Sharp, Fremont, Michigan, U.S.A., 6th December, 1897; 6 years. (Filed 22nd November, 1897.)

Claim.—1st. A snap hook comprising two members pivotally connected with each other, and formed at their front ends into hooks curved in opposite directions, and flattened at their adjacent faces, whereby they are adapted to rest one against the other to form an eye, and a spring for normally holding the members in closed position, one of said members having a widened portion extending rearwardly from the pivot-point over the widened rear part of the other member, whereby the hook ends may be readily separated by pressing the finger piece laterally against the tension of the spring, substantially as shown and described. 2nd. In a snap hook, the combination with a member formed at its front end into a hook and having its rear end flattened and formed with an eye, of a second member pivoted to the first member, and having its front ends formed into a hook adapted to fit against and form an eye with the hook of the first member, the said second member having a handle portion extending rearwardly from the pivot-point and arranged over the rear flattened portion of the first member, the said handle member having its end formed into a vertically disposed finger-piece having roughened sides, whereby the hook ends of said members can be readily separated, each of said members having a recess on its inner surface, and a spring arranged in said recess and having a coiled portion surrounding the pivot, the ends of the said spring being secured one to each of the said members, substantially as described.

No. 58,299. Wire Stretcher. (Tendeur de fil de fer.)

Robert J. Gardner, Nacogdoches, Texas, U.S.A., 6th December, 1897; 6 years. (Filed 17th November, 1897.)

Claim.—1st. A wire stretcher, comprising a pair of substantially L-shaped bars or members forming handle portions and engaging arms, and similarly disposed and pivoted together flat against each

other with the pivot disposed in a plane at right angles to both the handle portions and the arms, whereby the arms may be brought

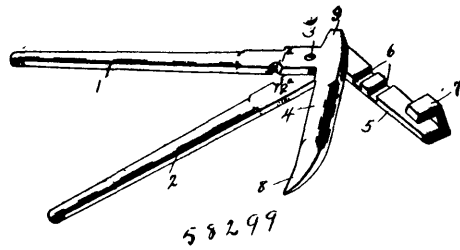

sufficiently close to clamp a fence, and are capable of being rotated against a fence-post to wrap a fence-wire around them and stretch the same to the desired tension, substantially as described. 2nd. A wire-stretcher, comprising a pair of L-shaped bars or members arranged flat against each other and pivoted together near their angles with the pivot disposed at right angles to their arms and handle portions, one of the members or bars being provided at the inner face of its arm with a wire-receiving groove, substantially as described. 3rd. A wire stretcher, comprising a pair of substantially L-shaped bars or members pivoted together near their angles and forming shanks or handle portions and wire-engaging arms, one of the arms being provided with a transversely-disposed wire-receiving loop, arranged to receive and support the other arm, whereby the wire is clamped in the loop, substantially as and for the purpose described. 4th. A wire-stretcher, comprising the L-shaped bar or member 1 provided at its angle with a heel forming an extension of the engaging-arm, the latter being pointed and slightly curved, the similar L-shaped bar or member 2 provided at the inner face of its engaging-arm with transverse grooves and having a substantially rectangular loop arranged at the outer end of its engaging-arm and adapted to receive the end of the other L-shaped bar or member, whereby the same is supported and the wire is clamped and a pivot connecting the bars or members and located adjacent to the angle of the same, substantially as described.

No. 58,300. Lifting Jack. (Cric.)

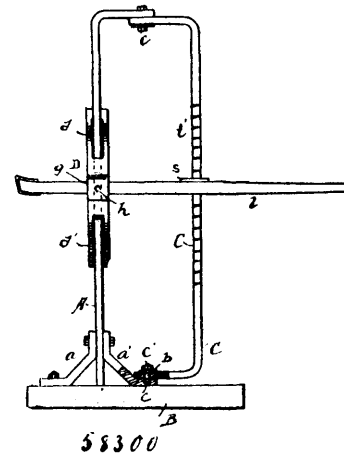

Richard Baker, Terre Haute, Indiana, U.S.A., 6th December, 1897; 6 years. (Filed 22nd November, 1897.)

Claim.—The combination of base B, notched standard A, notched guard C, pivoted to said base and standard, bolt c, bolt c', and the collar D, adjustable hanger D, and lever 1, all substantially as described and for the purpose set forth.

No. 58,301. Sleigh. (Traineau.)

Thomas Barton Cosley and Charles Robert Peterkin, both of Toronto, Ontario, Canada, 6th December, 1897; 6 years. (Filed 20th November, 1897.)

Claim.—1st. A sleigh or sled comprising the runners, the longitudinal bars and the circular braces placed in juxtaposition between the longitudinal bars and runners and bound together and to the longitudinal bars and runners and suitable cross-bars for connecting the runners together as and for the purpose specified. 2nd. A sleigh or sled comprising the runners, the longitudinal bars and the circular braces placed in juxtaposition between the longitudinal bars and runners and bound together and to the longitudinal bars and runners, suitable cross-bars for connecting the runners together

and a platform located on such cross bars as and for the purpose specified. 3rd. A sleigh or sled comprising the runners, the

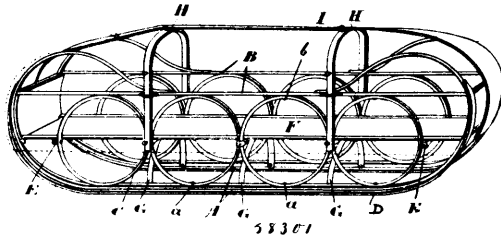

longitudinal bars and the circular braces placed in juxtaposition between the longitudinal bars and runners and bound together, and to the longitudinal bars and runners, the cross bars and metal straps connecting them to the contacting points of the braces as and for the purpose specified. 4th. A sleigh or sled comprising the runners, the longitudinal bars and the circular braces placed in juxtaposition between the longitudinal bars and runners and bound together, and to the longitudinal bars and runners, the cross-bars and metal straps connecting them to the contracting points of the braces and semi-circular braces secured at the top to the cross-bars and at the bottom to the runners, as and for the purpose specified. 5th. A sleigh or sled comprising the runners, the longitudinal bars and the circular braces placed in juxtaposition between the longitudinal bars and runners and bound together, and to the longitudinal bars and runners, suitable cross-bars for connecting the runners together and central supporting bows connected to the longitudinal bars and contacting points of the braces and a suitable top cover supported centrally by such bows and the ends and sides by the bows and bars of the sleigh, as and for the purpose specified.

No. 58,302. Shears. (Cisailles.)

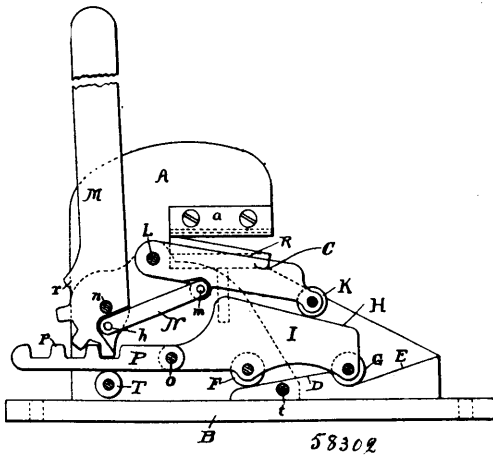

Joseph W. Jackson, assignee of James Burgess, both of Indianapolis, Indiana, U.S.A., 7th December, 1897; 6 years. (Filed 8th November, 1897.)

Claim.—1st. In shears for cutting metals consisting of a frame, provided with a base, said frame having a table and a stationary blade rigidly secured thereto, two incline planes placed tandem with the incline on the outer plane greater than the inner plane, said planes preferably integral with said frame, an arm pivoted to said frame at one end and the opposite end provided with a friction roller, a cutting blade secured to said arm, a slidable block having friction rollers on its lower end travelling in said incline planes of the frame, the top of said block having an incline tapering upward towards its centre on which said roller *k* travels, a friction roller on said frame, a rack having teeth slidable on said roller and pivotally connected to said incline block, an operating lever pivoted to said frame and having teeth on its lower end engaging with the teeth in said rack to advance said rack when said lever is pulled downward thereby raising said pivoted arm to close said knives, a lever connecting said lever and arm to pull said arm downward when said lever is in a vertical position, and a plate on one side to cover said mechanism, substantially as shown and described. 2nd. The herein described shears or knife for cutting iron and other metals, consisting of a main frame or support having a base and two incline planes placed tandem, with the outer incline at a greater angle than the inner one, a block having friction rollers travelling on said inclines, said block having an incline on its top, an arm pivoted to said frame at one end and a roller at its opposite or outward end

travelling on said incline, said arm having a cutting blade, a roller journalled to said frame, a rack slidable on said roller and pivoted to said incline block, an operation lever pivoted to said frame and having teeth on its lower end engaging with said rack, a lever connecting said lever to said arm to pull said arm to open position, and a plate on one side to cover mechanism, substantially as shown. 3rd. The combination of the frame A, having the base B, table C, and cutting blade *a*, the inclines D, and E, preferably made integral with said frame, the block I, having the incline H, on its top edge, and rollers F and G, travelling on the inclines D and E, respectively, the arm J pivoted to said frame at L and having the cutter blade R, and roller K travelling on said incline H, the roller T journalled to said frame, the rack P pivoted to said block I at O, and slidable on said roller, the operating lever M pivoted to the frame at *n*, and having the teeth *r* on its lower end and engaging with the teeth *p* of rack P, to advance said rack and press said pivoted arm upward, the connecting lever N pivoted to said operating lever at *h* and to said arm at *m* to pull said arm downward when said lever is in a vertical position and the plate *s* secured to the side of said frame by means of suitable bolts, substantially as shown and described.

No. 58,303. Manufacture of Fuel from Turf. (Fabrication de combustible de la tourbe.)

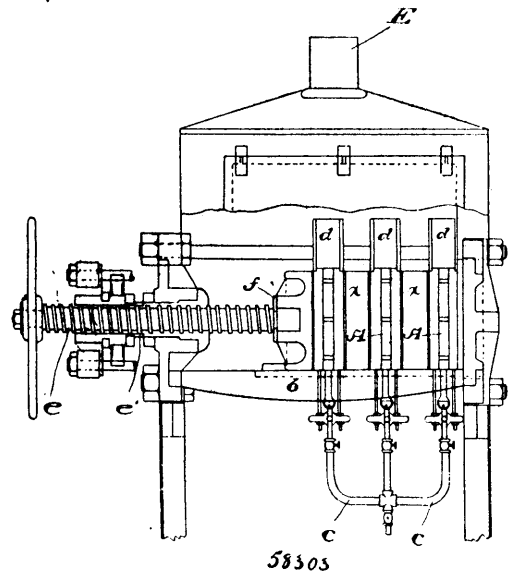

William Schoning, Hamsund, Lofoten, Norway, 7th December, 1897; 6 years. (Filed 8th June, 1896.)

Claim.—A process of manufacturing fuel from turf or peat by placing the turf between heated plates heated to a red heat and then compressing the same between these heated plates, so as to, at one and the same time, both compress and carbonize the turf or peat, substantially as and for the purpose specified.

No. 58,304. Slug-cutting Mechanism for Linotype Machines. (Mécanisme pour couper les espaces de machines linotypes.)

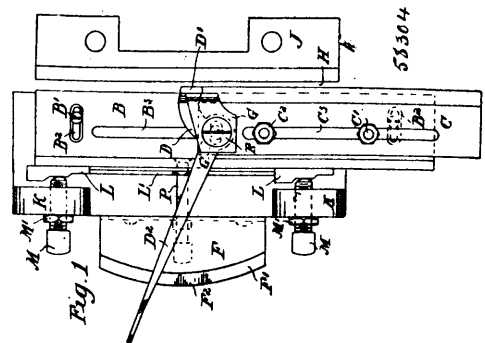

George William Mascord, Glenferrie, Colony of Victoria, Australia, 7th December, 1897; 6 years. (Filed 8th September, 1897.)

Claim.—1st. A pivoted cutting-lever as D, arranged to be moved radially in and out of line, with main slug-cutter, substantially as and for the purposes set forth. 2nd. In combination, a pivoted lever-cutter D, adjustable cutter-plate G, and main slug-cutter C, substantially as and for the purposes set forth. 3rd. In combination, adjustable shoe B, adjustable slug-cutters C and G, and pivoted lever-cutter as D, substantially as and for the purposes set forth. 4th. In combination, adjustable shoe B, carrying slug-cutters C, D, and G, adjustable stepped liners L, lugged casting K, and bolts M, substantially as and for the purposes set forth. 5th. The combination of shoe B, adjustable by screw-bolt B¹ passing through slot B², and by screw-bolt P, the slug-cutter C adjustably secured to the shoe by bolts C¹ passing through slot C² and by nuts C², lever D pivoted on cutter C, having long arm D² adapted to ride over raised portion F² on curved plate F secured to casting A, the cutter-plate G set on the face of lever D by means of pivot pin E and movable through slot G¹, the planing-knife J contiguous to passage H, the adjustable stepped liners L, L secured together by rod L¹, the lugged casting K, the screw M, and lock-nut M¹, substantially as specified.

No. 58,305. Process of Preparing Vegetable Glue.
(*Procédé pour la préparation de colle végétale.*)

iegfried Herzberg, Berlin, Germany, 7th December, 1897; 6 years.
(Filed 22nd October, 1897.)

Claim.—The process of preparation of vegetable glue, consisting in suspending five to thirty per cent of potato-meal in water, and adding two to five per cent of alkali thereto.

No. 58,306. Coin-freed Delivery Machine.
(*Machine à délivrer actionnée par une pièce de monnaie.*)

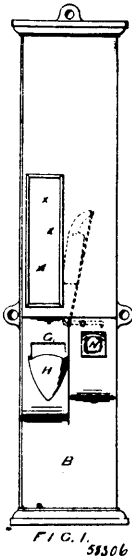

Alfred Hulme and John Williams, both of Manchester, England, 7th December, 1897; 6 years. (Filed 26th August, 1897.)

Claim.—1st. In coin-freed automatic delivery machines, the combination of a metal or other suitable outer casing, a delivery drum or wheel with ratchet-like periphery upon which the supply of commodities rests, a drum adjacent thereto for controlling said delivery drum, normally held locked, but released by the insertion of a coin, as hereinbefore described. 2nd. In coin-freed automatic delivery machines, the combination of delivery drum D, coin-freed drum A, levers or arms J pins O, springs K, P, and Q, mounted and operating as and for the purposes set forth. 3rd. For locking coin-freed automatic delivery machines and for indicating when such machines are empty, the combination with claws R, of levers S and U, and springs R¹ and T, rod U¹, and plate or semaphore W, mounted and operating under the action of weight V, as set forth.

No. 58,307. Oil Lamp. (*Lamp à huile.*)

Alfred John Riley, Birmingham, England, 7th December, 1897; 6 years. (Filed 14th September, 1897.)

Claim.—1st. The combination with lamp tanks or reservoirs and supply and overflow pipes, of a main oil supply or distributing tank having a compressed air chamber with means for charging same, a closed oil distributing chamber in connection with the said compressed air chamber, and an open top or overflow chamber, substantially as set forth. 2nd. The combination with a lamp tank or reservoir intermittently supplied with oil from a main distributing tank, of a three-way cock or tap, two of the ways which are opened

and closed together being arranged respectively to admit atmospheric air to the reservoir and to permit of the flow of oil to the

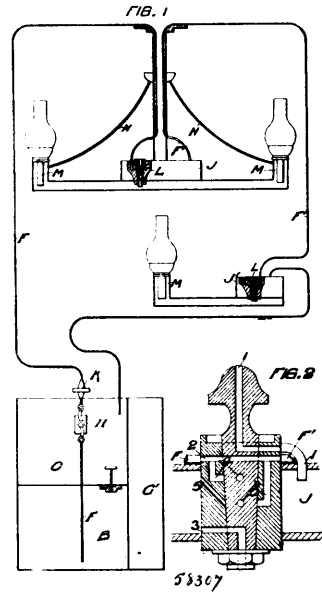

burners, whilst the third way which is opened when the other ways are closed and *vice versa*, admits oil to the reservoir from the intermittent supply pipe, substantially as set forth. 3rd. The combination with a lamp tank or reservoir intermittently supplied with oil from a main distributing tank, five-way cock or tap, three of such ways which are opened and closed together being arranged respectively to admit atmospheric air to the reservoir to permit of the flow of oil from the reservoir to the burners, and the oil from the main tank supply pipe to flow straight through the cock, whilst the other two ways, which are together opened when the aforesaid three ways are closed, and *vice versa*, are arranged respectively to admit oil to the reservoir from the intermittent supply pipe and to permit the overflowing oil to pass to the next lamp reservoir of a series, substantially as set forth. 4th. The construction and combination of oil lamps with burners fitted over containers receiving oil from a tank or reservoir integral with the lamp, such tank or reservoir forming part of the series of circuit of an intermittent oil supply system, substantially as set forth. 5th. The combination with the supply pipes of an intermittent system of oil distribution for lamps, of a two-way cock or tap, one way being arranged to convey the oil through the cock and thence to the lamps, and the other way for the return of the oil from: the supply pipes, substantially as set forth.

No. 58,308. Means for Operating Plug-cutting Mechanism in Linotype Machines. (*Moyen d'actionner les mécanismes pour couper les espaces dans les machines linotypes.*)

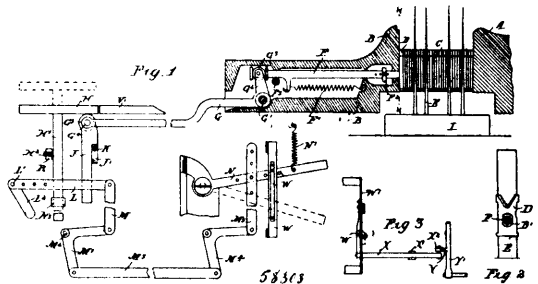

George William Mascord, Glenferrie, Colony of Victoria, Australia, 7th December, 1897; 6 years. (Filed 8th September, 1897.)

Claim.—1st. In a linotype machine, the combination of a slotted or recessed matrix, secured in position against the vice-jaw B, and a piston or plug F, set within the vice-jaw B, and arranged to enter the slot or recess in the matrix, through an opening in the vice-jaw B, by means of a spring F¹, secured at one end to the said piston and at the other to the vice-jaw B, substantially as specified. 2nd. In a linotype machine, the combination with a slotted or recessed matrix D, secured in position, of the vice-jaw B, the piston or plug F set within the vice-jaw B, means for moving the said piston or plug forward through an opening in the vice-jaw B into the slot or recess in the matrix, and means for moving the said plug F back-

ward, substantially as specified. 3rd. In a linotype machine, the combination of a vice-jaw B, the recessed matrix D, secured in position against the vice-jaw B, the piston F set within the vice-jaw and having an adjustable limitation piece F², the spring F¹ secured at one end to the plug F, and at the other to the vice-jaw B so that the plug may enter the recessed matrix D through an opening in the vice-jaw B, the pivoted bent lever G having an arm G² arranged to actuate the piston F, so that it may be withdrawn from the recessed matrix D, substantially as specified. 4th. In a linotype machine, the combination of a vice-jaw B, the recessed matrix D, secured in position, the piston F, provided with an adjustable limitation piece F², the spring F¹ secured at one end to the piston F, and at the other to the vice-jaw B, so that the plug may enter the recessed matrix D, through an opening in the vice-jaw B, the pivoted bent lever G having an arm G², arranged to actuate the plug F, so that it may be withdrawn from the recessed matrix D, the pawl J pivotally connected to the end of the long arm of the lever G, and having an inclined portion J¹, designed to engage with a pin K on the solid portion of the machine, the arm L, pivoted to movable stud bearing L², the link M pivoted to arm L, the pivoted crank lever M¹ pivotally connected to link M, the link M³ forming pivotal connection between crank lever M⁴ and crank lever M¹, the pivoted crank lever M⁴, the adjustable arm M⁵, pivotally connected with the crank lever M⁴, and the slug cutter lever N, actuated by the adjustable arm M⁵, substantially as specified. 5th. In a linotype machine, the combination of vice-jaw B, the recessed matrix D secured in position, the piston F provided with adjustable limitation piece F², the spring F¹ secured at one end to the plug F, and at the other to the vice-jaw B, the pivoted bent lever G, with short arm G², pivotally connected to the piston F, which is arranged to move on suitable bearings, the downward arm H¹ carrying the plate H, designed to bear on the long arm of the bent lever G, the pivoted crank lever R, with forked end to receive pin H² on the downward arm H¹, the sliding rod Q¹ pivotally connected at one end to the crank lever R, and the cam pieces P and T, on the elevator cam O, designed to engage with the other end of the sliding rod Q, substantially as specified. 6th. In a linotype machine, the combination of the slug-cutter lever N, the spring N¹ for keeping one end of the lever N normally raised, the spring latch W, the vertical guide plate W¹, on which the lever N slides, the sliding rod X connected at one end to the latch W, and carrying at its other end a friction roller X², an oscillating space band lever Y¹, carrying a cam-plate Y adapted to engage with the roller X², substantially as specified. 7th. In a linotype machine, the combination of a recessed matrix D, secured in position between the vice-jaws, the vice-jaw B with suitable openings, the piston F provided with adjustable limitation piece F², set within the vice-jaw B, and adapted to move on suitable bearings, the spring F¹, the pivoted bent lever G, having short arm G² provided with antifriction roller G³, pivotally connected with one end of the piston F, the pawl J, pivotally connected to the end of the long arm of bent lever G, with inclined portion J¹, the pin K, the spring J², the arm L, the movable stud-bearing L² pivoted to arm L, the link M, pivoted to arm L, the pivoted crank lever M¹ pivotally connected to link M, the link M³, forming pivotal connection between the crank lever M⁴ and crank lever M¹, the pivoted crank lever M⁴, the adjustable arm M⁵, pivotally connected with crank lever M⁴, the slug cutter lever N, actuated by arm M⁵, the downward arm H¹ adapted to move in guides H² and provided with pin H², the plate H, the safety stop piece V, the pivoted crank lever R, with forked end, the sliding rod Q¹, adapted to move in guides Q² and provided with friction roller Q, the stop piece Q⁴, the plunger spring Q³ with suitable bearings, the cam pieces P and T on elevator cam O, the spring N¹ for actuating lever N, the spring latch W, the vertical guide plate W¹, the sliding rod X operating in guide X¹, and carrying friction roller X², the oscillating space band lever Y¹ with cam plate Y, substantially as described and for the purpose specified.

No. 58,309. Music Clip. (Lien pour musiques.)

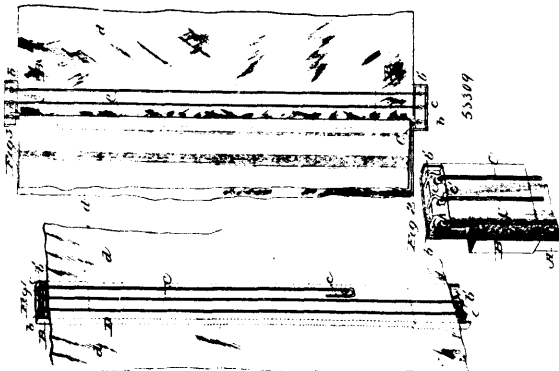

Reinhard Schumacher, San Francisco, California, U.S.A., 7th December, 1897; 6 years. (Filed 6th September, 1897.)

Claim.—1st. In a temporary binder, the combination with a suitable back, or clips secured to each end of the same, and elastics, each provided at each end with a hook adapted to be temporarily hooked over the clips, substantially as described. 2nd. In a temporary binder, the combination with a back proper of clips applied to the opposite ends of the same, and each having a lip forming a hook receiving space, and a plurality of elastics each provided at each end with a suitable hook adapted to be hooked over said lips to lie in said hook receiving spaces, substantially as described. 3rd. In a temporary binder, the combination with a suitable back of clips, applied at the opposite ends of the same, and provided with extended angular lips, and a plurality of elastics each provided at each end with a hook adapted to be secured between said angular lips and the body proper of the clip, substantially as described. 4th. In a temporary binder, the combination with a suitable back of spring clips, applied about the respective opposite ends of the same, elastic hooks provided with eyes adapted to receive the respective ends of the elastics, and a flexible covering for said back, provided with extended flaps adapted to be secured to suitable protecting covers, substantially as described.

No. 58,310. Apparatus for Sharpening Skewers. (Machine pour aiguiser les brochettes des bouchers.)

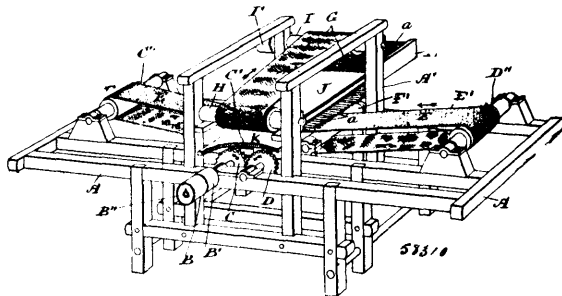

George McKenzie, Wingham, Ontario, Canada, 7th December, 1897; 6 years. (Filed 17th September, 1897.)

Claim.—1st. In a skewer-sharpening machine, the combination of two endless sand-belts suitably mounted on rollers journaled on the frame so as to have a certain pitch from the horizontal, a skewer table and a transverse endless belt so located as to bear on the series of skewer rods projecting over the sides of the skewer table so as to be in contact with the said belts and pass them transversely across the sand-belts through the machine, substantially as specified. 2nd. In a skewer-sharpening machine, the combination with the endless sand-belts E, E¹, of the gear wheels C and D, and the rollers C¹, D¹, and C¹¹, D¹¹, suitably journaled so as to give a certain pitch to the sand-belts, the taper rollers F, F¹, suitably located and journaled, the skewer table K, the endless transverse belt G on rollers H and I suitably journaled, and the guide-piece J, to keep the transverse belt G, in contact with the skewer rods passing through the machine, substantially as specified. 3rd. In a skewer-sharpening device, the combination with the skewer table K, and the transverse belt C, suitably operated by rollers, and a guide piece J, of a feed piece L, provided with grooves l, through which the skewer rods pass, so as to feed them evenly to the skewer table, substantially as specified. 4th. In a skewer-sharpening machine, the combination with the endless sand-belts E, E¹, of the gear wheels C and D, and the rollers C¹, D¹, and C¹¹ and D¹¹, suitably journaled so as to give a certain pitch to the sand-belts, the taper rollers F, F¹, suitably located and journaled, the skewer table K, the endless transverse belt C, on rollers H and I, suitably journaled, the guide piece J, and the feed piece L, provided with grooves l, substantially as described and for the purpose specified.

No. 58,311. Ticket Carrier. (Porte-billets.)

Richard Norman King, Montreal, Canada, 7th December, 1897; 6 years. (Filed 24th September, 1897.)

Claim.—1st. A pocket ticket carrier consisting of a pair of U-shaped sections adapted to be fitted together to form a shell, one or more narrow slits extending longitudinally of one end of said shell, and a yielding resistance adapted to bear towards the side or sides of said shell adjacent to which said slit or slits may be located, the space or spaces between said yielding resistance and side or sides of the shell being adapted to receive a number of tickets, for the purposes set forth. 2nd. A pocket ticket carrier comprising a shell having a pair of slits in one end thereof, said slits being located transversely of the carrier and one slit being located adjacent to each side edge of said end, a cross-bar located inside and transversely of said shell and adjacent to the opposite end thereof to that which is folded, a yielding resistance consisting of a flat resilient section folded midway of its length and adapted to straddle and be secured to said cross-bar, the ends of said resilient section being bent away from one another, for the purpose set forth. 3rd. A pocket ticket carrier consisting of a pair of U-shaped sections, one of said sections being composed of sides 5 and 6, cutaway as at 7 and joined at one

end by end section 8, the other being composed of sides 9 and 10 connected at one end by end section 11 of less width than the sides

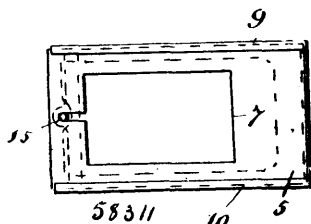

9 and 10, said sides being provided with grooves adjacent to the edges of their inner sides, said grooves being adapted to receive the side edges of the sides 5 and 6, the opposite ends of said sides 9 and 10 being connected by a cross-bar 12, a yielding resistance consisting of a flat resilient section folded about midway of its length and adapted to straddle and be connected to said cross-bar, the ends of said resilient section being bent away from one another, and the spaces between said resilient section being adapted to receive a number of tickets, substantially as and for the purpose set forth. 4th. A pocket ticket carrier consisting of a pair of U-shaped sections, one of said sections being composed of sides 5 and 6, cutaway as at 7, and joined at one end by end section 8, the other being composed of sides 9 and 10, connected at one end by end section 11 of less width than the sides 9 and 10, said sides being provided with grooves adjacent to the edges of their inner sides, said grooves being adapted to receive the side edges of the sides 5 and 6, the opposite ends of said sides 9 and 10 being connected by a cross-bar 12, a perforated projection upon said cross-bar, a yielding resistance consisting of a flat resilient section folded about midway of its length and adapted to straddle said cross-bar, the folded portion of said yielding resistance being cutaway to allow said projection to protrude therethrough, a pin adapted to take tightly into the perforation in said projection and having its ends flush with the outer surface of the sides 5 and 6, the ends of said resilient section being bent away from one another, and the spaces between said resilient section being adapted to receive a number of tickets, substantially as and for the purpose set forth.

No. 58,312. Electric Railway. (Chemin de fer électrique.)

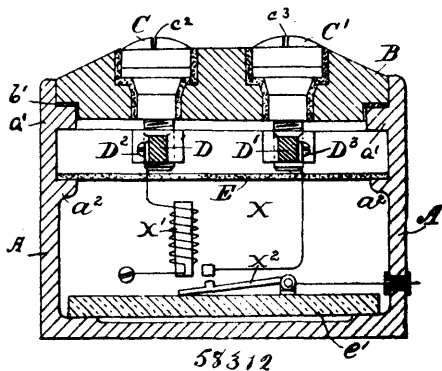

Frederick Carleton Esmond, London, England, 7th December, 1897; 6 years. (Filed 17th December, 1895)

Claim.—1st. In an electric railway, the combination of a supply conductor with pairs of contact points or spots located along the line of the railway, and normally insulated from the supply conductor, switches for connecting one or both of each pair of contact spots with the supply conductor, electro-magnets for throwing the switches, and means for closing the circuit of said magnets, depending for operation upon the presence of the car over or near the corresponding contact point. 2nd. In an electric railway, the combination of the supply conductor, insulated contact points or spots arranged in pairs along the surface of the track, with collectors adapted to engage said contact points, switches and electro-magnets for connecting one or both of the contacts with the supply conductor, and means for closing the circuit of the magnet of a given pair of contact points, depending for operation upon contact between said points and the car collectors. 3rd. In an electric railway, the combination of an insulated supply conductor with switch-boxes located along the line of way carrying at their top a pair of external surface contact points or spots with a magnet and switch enclosed and protected in said box for completing the motor circuit from the supply conductor to the car through one or both of

the contact points, collectors on the car, and means for closing the circuit through each magnet when the collectors rest upon the corresponding contacts. 4th. In an electric railway, a box having a lid carrying two insulated surface contact points each in electrical connection with a binding post on the interior of the box, and a circuit controller, housed in the box for connecting one or both of the contact points with a main supply conductor, in combination with means to secure the lid on the box, substantially as and for the purpose described. 5th. In an electric railway, a box having a lid carrying two contact points, each in electrical connection with a binding post on the interior of the box, and a circuit controller, housed in the box for coupling one or both of the contact points to a main supply conductor, in combination with shoulders on the interior of the box to which the lid is secured by means of braces bearing on the under side of said shoulder and secured to the lid by belts, substantially as described.

No. 58,313. Electric Railway. (Chemin de fer électrique.)

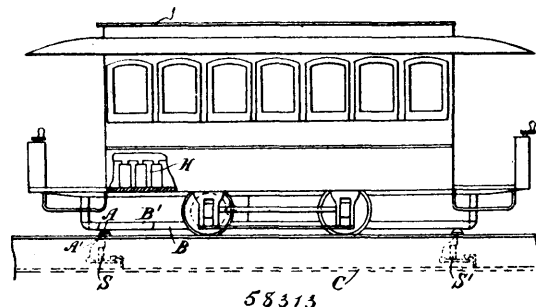

Frederick Carleton Esmond, London, England, 7th December, 1897; 6 years. (Filed 17th December, 1895.)

Claim.—1st. The combination in an electric railway, of a supply conductor, insulated working conductor sections, and an intermediate series of switches, with a circuit divided into multiple branches at a point between the supply conductor and the insulated sections, one of which branches leads to the motor directly from a given working conductor section, while the second branch leads to the motor through an electro-magnetic device, arranged to throw the switch of an advance section into working position, as set forth. 2nd. The combination in an electric railway of a supply conductor, with a double set of working conductor sections forming one branch of the motor circuit, normally open switches between the supply conductor and working sections, insulated contact makers on the car adapted to make contact with the different sections, and electrical connections normally connecting each pair of working conductor sections through a magnet coil adapted to operate the switch of that section. 3rd. The combination of a supply conductor and a double set of insulated working conductor sections, normally open electro-magnetic switches for each set of working sections, and a pair of contact-makers on the car forming a branched circuit to the motor, one branch passing through the switch of one set of sections and the other branch including the coil of the switch for the next succeeding section, as set forth. 4th. The combination in an electric railway of a supply conductor, insulated working conductor sections, switches for connecting and disconnecting the supply conductor and working conductor sections, a coil on each switch for closing and holding the switch closed, and a contact bar carried by the arc closing the circuit of the switch of an advance section and including it as part of a branch of the motor circuit supplied with current through the switch of the preceding section, as set forth. 5th. The combination of a supply conductor, a double set of working conductor sections, forming one branch of the motor circuit, electro-magnetically operated switches, which are closed as the car passes over the line by collector-bars establishing a branch of the motor circuit through the coil operating a switch of an advance section, and a switch similarly controlled in the circuit of the return supply conductor, as set forth. 6th. The combination of a supply conductor, insulated working conductor sections, and intermediate electro-magnetically controlled switches for connecting those working conductor sections which are in the neighbourhood of the car with the supply conductor, and a storage battery on the car serving as a source of current to energize the line switches and close them when desired. 7th. The combination of a line conductor, a double set of insulated working conductor sections, insulated contact bars engaging such sections, a storage battery on the car, and a switch for connecting the terminals of the battery with the insulated contact bars, for the purpose of closing the line switches, as set forth. 8th. The combination of the supply conductor, sectional working conductor and switches with a battery on the car for picking up the magnets, a switch for closing the circuit of the battery, and a magnet forming part of the circuit and adapted to automatically re-open the battery switch, as set forth.

No. 58,314. Method of and Apparatus for Sinking shafts. (*Méthode et appareil pour percer un puits.*)

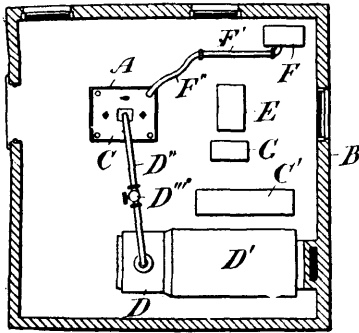

58314

Samuel Hatt Haycock, Iroquois, and Edward Burton Haycock, Ottawa, both of Ontario, Canada, 7th December, 1897; 6 years. (Filed 17th November, 1897.)

Claim.—1st. In a sinker, the combination of a flat pyramidal top, a nozzle at the apex, a vertical rim or flange at the edge, a strengthening bar along the lower edge of the rim or flange, a non-conducting lining to the top, an inner casing consisting of crown and rim a little distance from the outer one so as to form a space, and the rim not extending as far down as the outer one, and provided with a strengthening bar, connections at intervals between the outer casing and the inner, and cross-stays connecting said outer rim, substantially as set forth. 2nd. In a sinker, the combination of a flat pyramidal top, a nozzle at the apex, a vertical rim or flange at the edge strengthened at its lower edge, a non-conducting lining to the top, an inner casing consisting of crown and rim similar to the outer one but smaller, and a little distance from it so as to form a space and its rim strengthened at the lower edge not extending as far down as the outer one, connections at intervals between the inner and outer casings, vertical pipes in the spaces between the flanges having lateral bents below and projecting above the top and provided with means of connecting them with hose or closing them, substantially as set forth. 3rd. A radiating apparatus or sinker approximating the shape of an inverted funnel and consisting of a flattened funnel-shaped top with central nozzle and hose coupling and having a vertical flange or rim at the lower or outer edge, an inner casing similar to the outer one but smaller and with crown more depressed and forming a radiating surface with a space between it and the outer one that is open at the lower edges of the rims, substantially as set forth.

No. 58,315. Bone Cutter. (*Machine pour couper les os.*)

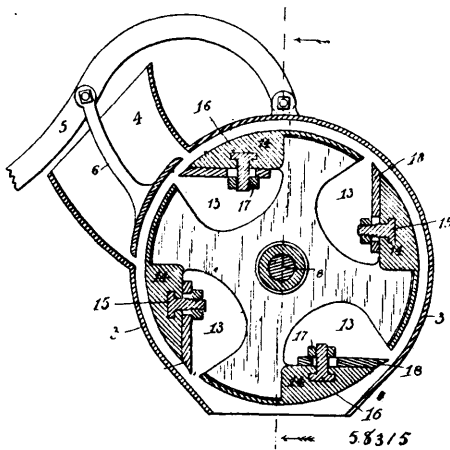

58315

The James Smart Manufacturing Company, Brockville, Ontario, Canada, assignee of William Taylor and Albert A. Dowsley, both of Brockville, Ontario, Canada, 9th December, 1897; 6 years. (Filed 3rd August, 1897.)

Claim.—A bone cutting machine, comprising a supporting stand 2, a wheel casing or shell 3, mounted thereon and having a feed opening or hopper 4, and a discharge orifice at the bottom, a lever 5, fulcrumed to said casing at the top, and having a plunger 6, entering said hopper, a rotary cutter head 7, provided with knives 18, arranged parallel to the diameter in circumferential recesses 13,

and rotated by a shaft 8, passing therethrough and geared wheels 9 and 10, all operating as set forth.

No. 58,316. Brush-Holder for Dynamo Electric Machines. (*Porte-brosse pour machines dynamo électrique.*)

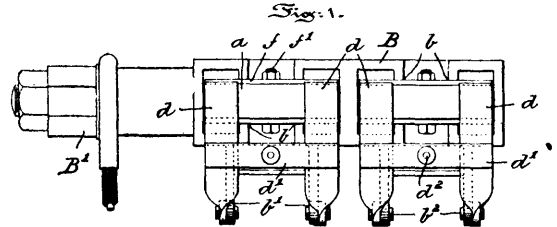

58316

Robert Nichuuls Simperts, assignee of James Henry Yearsley, both of Philadelphia, Pennsylvania, U.S.A., 9th December, 1897; 6 years. (Filed 23rd June, 1897.)

Claim.—1st. In a brush-holder for dynamos, a box in which the brush is adapted to be fed towards the commutator, two arms pivoted at one end to the box and having their free ends resting upon the brush, a cross-piece or bridge uniting said arms, and a spring adapted to depress said bridge towards the box, whereby the arms are caused to press upon the brush with a constant and uniform pressure, substantially as described. 2nd. In a brush-holder for dynamos, a box in which the brush is adapted to be fed towards the commutator, two arms pivoted at one end to said box and having their free ends resting upon the brush, a cross-piece uniting said arms, a threaded pin passing through said cross-piece, a spring securing one end of said pin or bolt to the box, and adjusting and jam nuts adapted to advance and retract on said pin through the cross-piece, substantially as and for the purposes described.

No. 58,317. Petroleum Lamp for Incandescence Light. (*Lampe à pétrole pour lumières incandescentes.*)

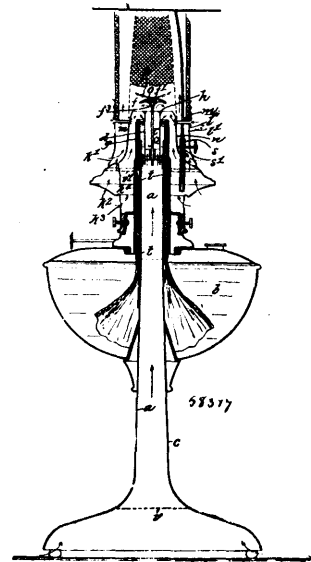

58317

Arthur Duffek and Johann Kohn, both of Vienna, Empire of Austria, 9th December, 1897; 6 years. (Filed 17th May, 1897.)

Claim.—1st. In a central draft oil lamp, the combination with the burner, composed of a central draft tube and a concentric tube for reception of the wick and means for dividing the current of air ascending the said central draft tube and directing said divided currents laterally across and downwardly towards the upper end of said burner, of a gallery constructed to receive an incandescence mantle and a chimney, said gallery provided with air ducts arranged to direct concentric currents of air into and around said incandescence mantle, substantially as and for the purpose set forth. 2nd. In a central draft oil lamp, the combination with the burner composed of a central draft tube and a concentric tube for the reception of the wick, and means for dividing the current of air ascending the said central draft tube and directing said divided currents laterally across and downwardly towards the upper end of said burner, of a gallery constructed to receive an incandescence mantle and a chimney, said

gallery provided with air ducts arranged to direct concentric currents of air into and around said incandescent mantle, and with air ducts arranged to direct currents of air radially across the burner at or near its upper end, substantially as set forth. 3rd. In a lamp such as described, the combination with the gallery and the incandescent mantle adapted to seat thereon, of adjusting devices for adjusting the said mantle relatively to its seat on the gallery, consisting of a rack bar *s* from which said mantle is supported, said rack bar having sliding motion in a guide in the gallery, a shaft having bearings in said gallery and a pinion *s'* on said shaft in gear with said rack bar, substantially as and for the purpose set forth. 4th. In a lamp such as described, a wick tube composed of two concentric tubes, the inner one constituting the central draft tube, said concentric tubes having capillary ducts formed on or in their proximate faces or having their proximate faces covered with a foraminous material, for the purpose set forth. 5th. In a lamp such as described, the combination with the central draft tube *a* and a short tube *d* arranged in its upper end to divide said draft tube into two concentric flues or passages, of a concavo-convex flame spreader *f*, having an axial conical portion *f'* on its underside and a stem extending from said conical portion axially into the tube *d*, said flame spreader held above the outlet of the central draft tube, substantially as and for the purpose set forth. 6th. In a lamp such as described, the combination with the central draft tube and a short tube arranged therein to divide the same into concentric passages, of a convex flame spreader *f*, provided with passages *o*, and a concavo-convex or cup-shaped deflecting disc arranged on the convex face of the said spreader with their convex surfaces in contact, substantially as and for the purpose set forth. 7th. In a lamp such as described, the combination with the central draft tube and a short tube *d* arranged therein at its upper end to divide said draft tube into concentric passages, of a substantially concavo-convex hollow flame spreader connected with the tube *d*, and openings in the outwardly flaring deflecting surface of said spreader or in the tube *d* proximate to such spreader, substantially as and for the purpose set forth. 8th. The combination in a lamp such as described, with the central draft tube and the short tube *d* in its upper end, of a ring *h* inserted into the inner tube *d* and having concave inner and outer surfaces, for the purpose of contracting the air currents passing up between the tube *d* and the flame spreader or wick tube, substantially as described. 9th. In a lamp such as described, the combination with the gallery and the central draft tube, of foraminous diaphragms *r* and *r'* interposed in said gallery and in said draft tube near its inlet for preventing an intermittent action of the air currents, substantially as described.

No. 58,318. Platen Printing Presses.
(*Presse à imprimer.*)

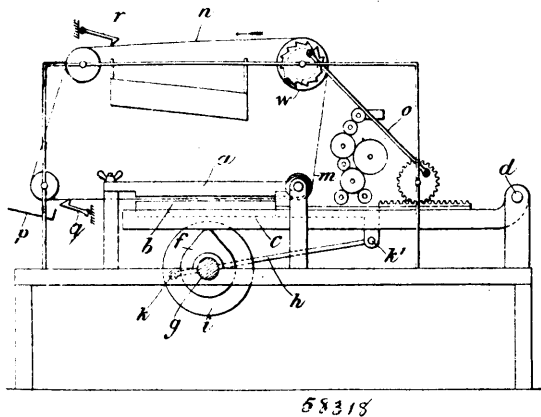

Albert Joisten and Joseph May, both of Cologne, Empire of Germany, 9th December, 1897; 6 years. (Filed 26th April, 1897.)

Claim.—The combination with an oscillatory frame *c* having longitudinal guides, of a form plate *b* in said guides, means for moving said form plate longitudinally back and forth in said guides, a platen *a*, a rotary cam *f*, adapted to periodically lift said frame *c* to bring said form plate against the platen when the form plate is in one of its end positions, and a stationary inking train so located that the form plate moves in contact therewith while the frame *c* is in its lower position.

No. 58,319. Pan Lifter. (*Appareil pour soulever les casseroles.*)

Pauline Abeles, New York, State of New York, assignee of Stephen P. Rush, Tyrone, Pennsylvania, U.S.A., 9th December, 1897; 6 years. (Filed 24th November, 1897.)

Claim.—1st. A lifter of the class described, comprising a lifting-bar, a supporting-blade secured thereto and adapted to receive a vessel for lifting the same, a clamping-bar arranged upon said lifting-bar, a link connected to the lifting and clamping-bars and adapted to per-

mit said clamping-bar having a hinged and slidable movement upon the lifting-bar, and means for retaining the vessel upon the support-

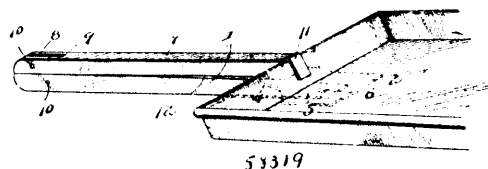

ing-blade, substantially as set forth. 2nd. A lifter of the class described, comprising a lifting-bar, a supporting-blade secured thereto and adapted to receive a vessel for lifting the same, a clamping-bar arranged upon said lifting-bar, a link connected to said lifting and clamping-bars, the points of connection of said link with the lifting and clamping-bars being diagonally opposite to each other thereby permitting said clamping-bar having a hinged and slidable movement upon the lifting-bar, and means for retaining the vessel upon the supporting-blade, substantially as set forth. 3rd. A lifter of the class described, comprising a lifting-bar, a supporting-blade secured thereto and adapted to receive a vessel for lifting the same, a clamping-bar arranged upon said lifting-bar, said lifting and clamping bars being provided with slits formed in the ends opposite to the supporting-blade, a link connecting the lifting and clamping-bars, said link having its ends pivotally secured in the slits of the lifting and clamping-bars and thereby permitting the clamping-bar having a hinged and slidable movement upon the lifting-bar, and a clamping-hook secured to the clamping-bar and adapted to engage the vessel for retaining the latter upon the supporting-blade, substantially as set forth.

No. 58,320. Lock. (*Serrure.*)

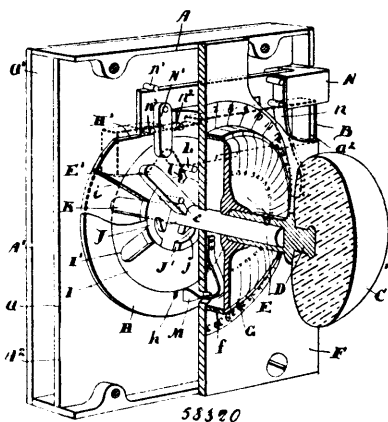

William Fox, Mille Roches, and William Campbell, Crookston, all in Ontario, Canada, 9th December, 1897; 6 years. (Filed 20th November, 1897.)

Claim.—1st. In a combination lock, in combination, the handle, the shank, the disc, the flanged annular plate, the key arm secured to the shank, the central moving plate, outer moving plate and the retaining plate, the radial slot in the outer annular plate corresponding in size and shape to the outer end of the key arm, the radial slot in the inner annular plate corresponding in width to the width of the key arm, the slot in the division plate and means for bringing the slots in the annular plates opposite the slots in the division plates and the bolt designed to be operated by the key arm when passed through the slots when registered, as and for the purpose specified. 2nd. In a combination lock, in combination, the handle, the shank, the disc, the flanged annular plate, the key arm secured to the shank, the central moving plate, outer moving plate and the retaining plate, the radial slot in the outer annular slot corresponding in size and shape to the outer end of the key arm, the radial slot in the inner annular plate corresponding in width to the width of the key arm, the slot in the division plate and the pin in the outer annular moving plate, the pin in the key arm and the concentric slot on the inner annular plate and bolt designed to be operated by the key arm when passed through the slots when registered, as and for the purpose specified. 3rd. In a combination lock, in combination the handle, the shank, the disc, the flanged annular plate, the key arm secured to the shank, the central moving plate, outer moving plate and the retaining plate, the radial slot in the outer movable plate corresponding in size and shape to the outer end of the arm, the radial slot in the inner annular plate corresponding in width to the width of the key arm, the slot in the division plate,

means for bringing the slots in the annular plate opposite the slots in the division plate, the clamping spring connecting the outer moving plate to the inner moving plate and the bolt designed to be operated by the key arm when passed through the slots when registered, as and for the purpose specified. 4th. In a combination lock, in combination, the handle, the shank, the disc, the flanged annular plate, the key arm secured the shank, the central moving plate, outer moving plate and the retaining plate, the radial slot in the outer invariable plate corresponding in size and shape to the outer end of the arm, the radial slot in the inner annular plate corresponding in width to width of the key arm, the slot in the division plate, means for bringing the slots in the annular plates opposite the slots in the division plate, and the spring fitting within the combination disc and designed to extend into the notches in the outer moving disc and the retaining disc when the handle is pushed in and the bolt designed to be operated by the key arm when passed through the slots when registered, as and for the purpose specified. 5th. The combination with the handle and key arm, of the latch spring-held in the outer position, the depending link, the pin on one side of the end of the latch abutting the link and the pin on the opposite side of the link on the division plate, as and for the purpose specified.

No. 58,321. Paint. (Peinture.)

The Publishing, Advertising and Trading Syndicate, assignee of Frederick Weaver Oliver, all of 40 King Street, Cheapside, London, England, 9th December, 1897; 6 years. (Filed 5th November, 1895.)

Claim.—A paint consisting of liquid celluloid either pure or mixed with pigment, substantially as described.

No. 58,322. Hose Nipple. (Mamelon de tuyau.)

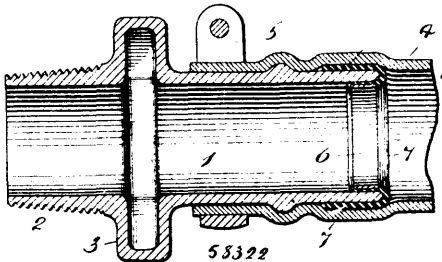

Jennie L. Dale, assignee of Charles H. Dale, all of New York, State of New York, U.S.A., 9th December, 1897; 6 years. (Filed 19th November, 1897.)

Claim.—1st. A cap or facing for a metallic nipple, the same consisting of a portion of soft yielding material extending over the end and exterior part of the nipple and a ring of hard inelastic material upon the interior of the nipple, whereby the soft yielding portion is secured and held in position, substantially as specified. 2nd. A cap or facing for a metallic nipple, the same consisting of a portion of soft yielding material extending over the end and exterior part of the nipple and a ring of hard inelastic material made integral therewith and fitting the interior of the nipple, whereby the soft yielding portion is secured and held in position, substantially as specified. 3rd. A cap or facing for a metallic nipple, the same consisting of a portion of soft rubber extending over the end and exterior part of the nipple, and a metallic ring coated with copper and located in the interior of the nipple, said soft rubber portion being vulcanized to the metallic ring, substantially as specified.

No. 58,323. Button Attaching and Detaching Implement. (Appareil à attacher et détacher les boutons.)

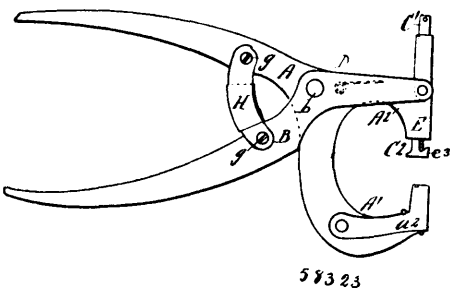

The McKenney Button Fastening Company, assignee of Franklin S. McKenney, all of Detroit, Michigan, U.S.A., 9th December, 1897; 6 years. (Filed 19th November, 1897.)

Claim.—1st. The pivotally connected jaws for setting a button fastening, said jaws provided with cutters for detaching a button, said cutters having in combination therewith a shield, substantially as set forth. 2nd. The pivotally connected jaws, having in combination therewith a die spindle reciprocatory through one of said jaws, and a removable and interchangeable button-holding device sleeved upon said die spindle, substantially as set forth. 3rd. The pivotally connected jaws, having in combination therewith a die spindle reciprocatory through one of said jaws, and a button-holding device sleeved upon said die spindle, said device made tubular at its upper end and having a spring tension upon the lower end of the die spindle, the lower extremity of the device formed with spring arms to clamp the eye of a button, substantially as set forth. 4th. The pivotally connected jaws, one of which is provided with a seat for a pronged fastening, having in combination therewith clamping arms to engage a fastener upon the seat, and additional guards to shield the prongs of the fastening, said guards having a vertically and laterally movable engagement with one of said jaws, substantially as set forth. 5th. The pivotally connected jaws, having in combination therewith a die spindle reciprocatory through one of said jaws, and a button-holding device constructed with a tubular portion at its upper end sleeved upon the die spindle, and with depending arms to support and clamp the shank of a button, said arms provided with a stop to centre the end of the shank of the button under the centre of the die, substantially as set forth.

No. 58,324. Box Attachment. (Attache de boites.)

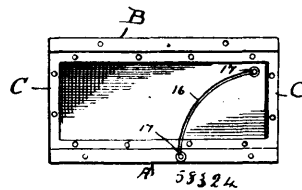

James Harvey Morlan, Arthur Hiram Wagner, and Robert Luke O'Donnell, all of Kansas City, Kansas, U.S.A., 9th December, 1897; 6 years. (Filed 17th November, 1897.)

Claim.—1st. In a collapsible or knock-down crate, the combination with a bottom of longitudinal strips connected to the bottom and rebent on themselves, thereby providing guide-grooves, side-pieces, longitudinal connecting strips secured to the side-pieces and provided with rebent portions, the rebent portions of one strip sliding in the groove of the other strip in each instance, detachable end-pieces, a cover, and a fastening for securing the cover in position. 2nd. In a collapsible or knock-down crate, the combination with a bottom of longitudinally movable and detachable sides, rebent connecting-strips secured to the sides inside the crate, ends having vertical connecting strips that interlock with and slide in the aforementioned strips whereby the ends may be moved vertically, a vertically removable partition, a similar connection between it and the sides, a removable cover, and a fastening device. 3rd. In a collapsible or knock-down crate, the combination with a bottom having rebent connecting-strips at its opposite longitudinal edges, said sides having similar longitudinal connecting-strips interlocked with the connecting-strips at the bottom, and said sides likewise being provided with upper and similar connecting strips, a cover having similar connecting-strips interlocking with and sliding longitudinally in the upper connecting-strips of the sides, and vertically removable ends connected to the sides by similar connecting-strips.

No. 58,325. Lock and Fastener. (Serrure et attache.)

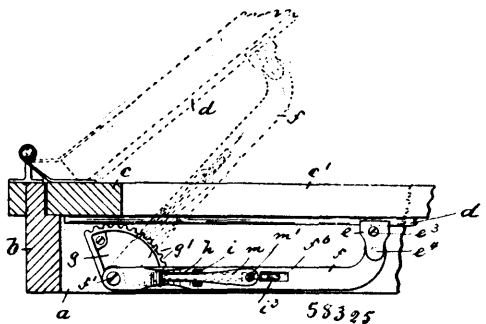

Fred. W. Wentworth, assignee of John Chase, both of Paterson, New Jersey, U.S.A., 9th December, 1897; 6 years. (Filed 17th November, 1897.)

Claim.—1st. The combination with a window frame and the blind hinged thereto, of a segmental-shaped block on the frame and

adjacent to the hinged portion of the blind, an arm or lever pivotally secured with its inner end to said segmental-shaped block and having its outer end slidingly and pivotally connected with the blind, and a spring-controlled locking device carried by said arm or lever and adapted to engage said segmental-shaped block, substantially as and for the purposes described. 2nd. The combination with a window frame and the blind hinged thereto, of a rail on said blind, a block slidingly arranged on said rail, a segmental-shaped block on the window frame and adjacent to the hinged portion of the blind, an arm or lever pivotally connected with its inner end to said segmental-shaped block and with its outer end to the sliding block, and a spring-controlled locking device carried by said arm or lever and adapted to engage said segmental-shaped block, substantially as and for the purposes described. 3rd. The combination with a window frame and the blind hinged thereto, of a rail on said blind, a block slidingly arranged on said rail, a segmental-shaped block on the window frame and adjacent to the hinged portion of the blind and provided in its periphery with a series of holes or notches, an arm or lever fulcrumed with its inner end to the centre of said block and having its outer end slidingly and pivotally connected with the blind, and a spring-controlled locking device carried by said arm or lever and adapted to engage the holes or notches in the segmental-shaped block, substantially as and for the purposes described. 4th. The combination with a window frame and the blind hinged thereto, of a rail on said blind, a block slidingly arranged on said rail, a segmental-shaped block on the window frame and provided in its periphery with a series of holes or notches, an arm or lever pivotally connected with its inner end to the centre of said segmental-shaped block and with its outer end to the sliding block, and a spring-controlled locking device carried by said arm or lever and adapted to engage the said holes or notches in the segmental-shaped block, substantially as and for the purposes described. 5th. The combination with a window frame and the blind hinged thereto, of a rail on said blind, a block slidingly arranged on said rail, a segmental-shaped block on the window frame and provided in its outer periphery with a series of notches, an arm or lever pivotally secured with its inner end to the centre of said segmental-shaped block and provided with an elongated slot, and having its outer end pivotally connected with the sliding block, a bar or bolt fulcrumed on said arm or lever and in said elongated slot, and provided at its inner end with a downwardly extending pin or projection adapted to engage the notches in the segmental-shaped block and having its outer end projecting through the arm or lever, and a flat spring for normally holding said fulcrumed bolt or bar in engagement with the notches in the segmental-shaped block, substantially as and for the purposes described.

No. 58,326. Banjo, etc. (Banjo, etc.)

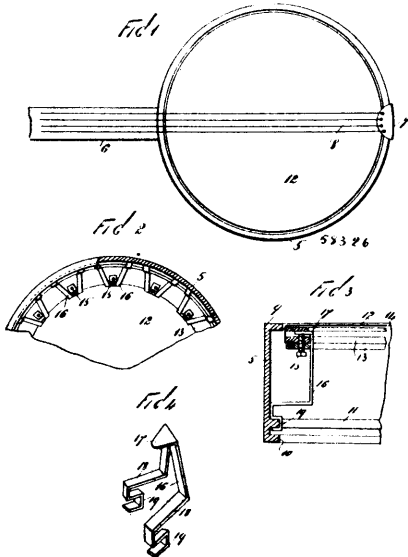

Horace Ozias Kellogg and Margaret Thressa Huntington, both of New York, State of New York, U.S.A., 9th December, 1897; 6 years. (Filed 27th August, 1897.)

Claim.—1st. A banjo or similar musical instrument, comprising a head or band to which the neck of the instrument is secured, and a frame consisting of circular plates to which the drum-head or sounding-board of the instrument is secured, said frame being supported within the head or band by bracket arms, which are connected therewith, and which are adapted to engage or to be connected with said head or band, and means for adjusting the tension of said drum-head or sounding-board, consisting of screws which are passed through said supporting plates and adapted to bear on the heads of

the said bracket arms, substantially as shown and described. 2nd. A banjo or similar musical instrument, comprising a head or band to which the neck of the instrument is secured, and a frame consisting of circular plates to which the drum-head or sounding-board of the instrument is secured, said frame being supported within the head or band by bracket arms, which are connected therewith and which are adapted to engage or to be connected with said head or band, said frames with which the drum-head or sounding-board is connected being also provided with an annular plate which is mounted thereover, and said frame being also provided with set screws which are passed therethrough, and which are adapted to bear on the heads of said bracket arms, substantially as shown and described. 3rd. A banjo or similar instrument comprising a head or band as 5, a frame by which the drum-head or sounding-board is connected, consisting of annular plates as 13, and movable plate as 14, mounted over said frame, said annular plate which constitutes said frame being also provided with screws or bolts as 15, which are passed therethrough, and bracket arms as 16, by which said frame is supported, substantially as shown and described. 4th. A banjo or similar instrument comprising a head or band as 5, a frame with which the drum-head or sounding-board is connected, consisting of annular plates as 13, and a movable plate as 14, mounted over said frame, said annular plate which constitutes said frame being also provided with screws or bolts as 15, which are passed therethrough, and bracket arms as 16, by which said frame is supported, said bracket arms being adapted to engage at their lower ends with an annular head or projection as 11, formed on or secured to the inner walls of the head or band, substantially as shown and described.

No. 58,327. Clock. (Horloge.)

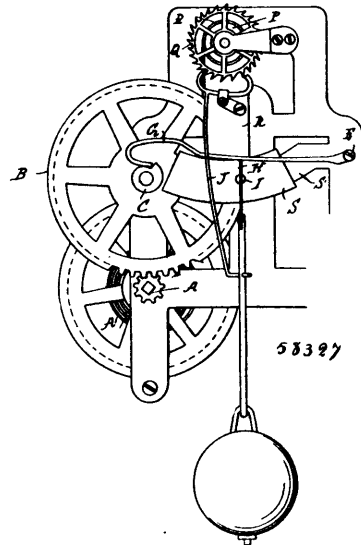

Joseph Schulte and Thomas J. Field, both of Monterey, California, U.S.A., 9th December, 1897; 6 years. (Filed 28th September, 1897.)

Claim.—1st. In a clock, a regulating device consisting of a fulcrumed arm, a cam connecting with the clock mechanism and actuated thereby, and a regulator movable in unison with the movement of the cam-actuated arm, whereby the beats of the clock are increased in proportion as the spring which gives the impulse becomes weakened. 2nd. In a clock, the combination with a spring and the mechanism actuated thereby, of a fulcrumed lever arm having one end adapted to be moved by a cam actuated by a moving part of the clock mechanism, and a regulator connected with and actuated by said lever, whereby the pendulum or regulator is shortened, and the corresponding beats are increased in proportion as the impelling spring becomes weaker by uncoiling. 3rd. In a clock, the combination with the coiled spring and mechanism impelled thereby, of a fulcrumed lever, a cam with which one end of said lever arm engages and by which it is gradually turned about its fulcrum point by the movement of the clock mechanism, a regulator, a quadrant which is connected so as to have a frictionally controlled movement about the common centre of the two, a connection between the lever arm and the quadrant whereby it and the lever are automatically moved by the movement of the cam transmitted through the lever cam. 4th. In a clock, a regulating mechanism whereby the impulse of the escapement is increased in proportion as the tension of the winding spring is reduced, a disc centrally mounted with relation to the escapement wheel, a pallet and verge carried by a downwardly projecting extension of the disc, the verge connecting with the pendulum rod, whereby the tilting of the clock allows the disc and extension to move and arrange itself automatically with

relation to the vertical position of the pendulum. 5th. In a clock, a disc centrally pivoted with relation to the escapement wheel, a pendulum suspended therefrom, a pallet and verge through which connection is made with the pendulum rod whereby the impulses of the escapement are imparted thereto, an extension downwardly from the disc with a segment at the lower end and a segmental surface against which it makes contact to prevent free oscillations, while allowing the segment to tilt from one side to the other in unison with the central position of the pendulum rod, whereby the beats of the latter are rendered even.

No. 58,328. Toy. (Jouet.)

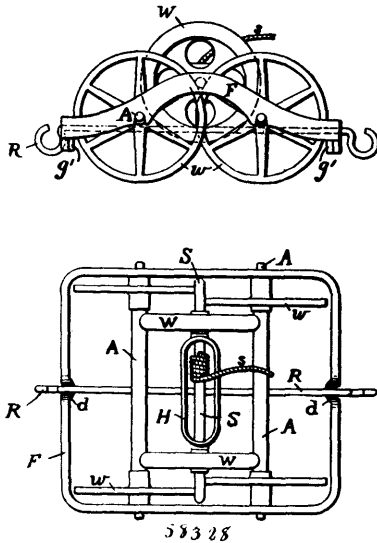

Clark & Boyer, assignees of Israel D. Boyer and Edith E. L. Boyer, all of Dayton, Ohio, U.S.A., 9th December, 1897; 6 years. (Filed 27th October, 1897.)

Claim.—1st. In a toy vehicle, the combination of one or more axles, each having a pair of running wheels located near its ends, and having a shoulder back of each running wheel to prevent it from moving inwardly on the axle, a frame to pass outside of the running wheels and having notches on its underside to pass over the projecting ends of the axles and form bearings therefor, a rod passing longitudinally along the vehicle, between the wheels and under the axles, and having its ends supported on the transverse members of the frame, means to prevent said rod from becoming accidentally displaced, the whole construction being such that the rod prevents the frame from lifting off the axles, while the frame confines both wheels and axle against endwise motion, substantially as specified. 2nd. In a toy vehicle, one or more axles with their running wheels, a frame having notches on its underside to fit over the axles and form bearings therefor, a rod passing longitudinally along the vehicle between the wheels and under the axles and having its ends supported by the frame, means to prevent said rod from being accidentally displaced, all in combination substantially in the manner and for the purpose specified. 3rd. In a toy wagon, two pairs of wheels with their axles, a frame having on the underside thereof four notches to fit over the axles and form bearings therefor, a rod passing longitudinally along the wagon, below the wheels and under the axles and over the transverse members of the frame at either end of the wagon, notches in said transverse end pieces of the frame to receive the said rod and prevent it from moving laterally, the ends of the rod bent downwardly, all in combination substantially in the manner and for the purposes specified. 4th. In a toy wagon, two axles each having a pair of wheels thereon, a frame having on its underside four notches to fit over the axles and form bearings therefor, a rod passing longitudinally along the wagon, between the wheels and under the axles, the two ends of the rod resting on the transverse members of the frame at either end of the wagon, means to prevent said rod from accidentally coming out of place, all combined substantially in the manner and for the purposes specified. 5th. In a locomotive toy, four running wheels arranged in two pairs near together and in such manner that the adjacent wheels form an angle in which a shaft may lie, an inertia wheel fixed to a shaft, said shaft lying in the angle formed by the adjacent pairs of running wheels, the whole in combination and arranged to operate substantially in the manner and for the purposes specified. 6th. A locomotive toy consisting of a vehicle having four running wheels arranged in two pairs near together and in such manner that the adjacent wheels form an angle in which a shaft may lie, an inertia wheel fixed to a shaft and independent of the vehicle, a handle loosely mounted on the shaft of the inertia wheel to enable

the live wheel to be placed upon the vehicle with its shaft resting in the angle formed by the four running wheels, the inertia wheel then acting as a motor and causing the vehicle to move ahead, substantially as specified.

No. 58,329. Coffee Roasting Device. (Brûloir à café.)

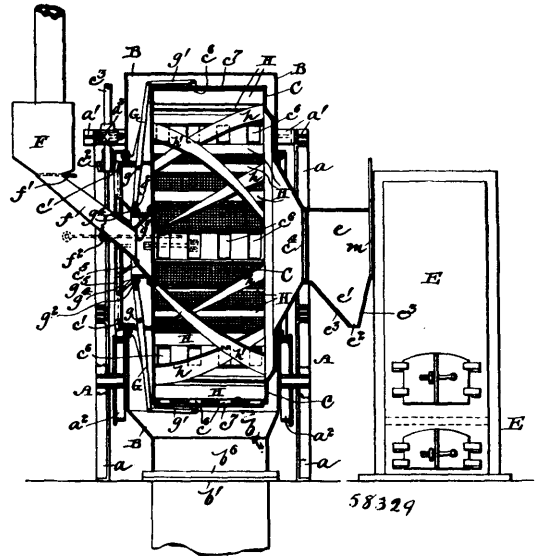

John K. Okell and Otto J. Peterson, Philadelphia, Pennsylvania, U.S.A., 9th December, 1897; 6 years. (Filed 2nd November, 1897.)

Claim.—1st. In a coffee roaster, the combination of a furnace having a combustion chamber immediately adjoining the roasting drum of said roaster, a cylindrical, revoluble roasting drum having a flaring mouth opening directly into the interior of the drum; and communicating directly with the interior of the combustion chamber of the furnace, said drum being approximately very shallow in depth but of a relatively large diameter, lifting agitators or pockets arranged within the drum for carrying the coffee up to a considerable height and allowing it to fall in a shower through the centre of the drum and through the flames and heat direct from the furnace, substantially as described. 2nd. In a coffee roaster, the combination of a furnace having a combustion chamber immediately adjoining the roasting drum of said roaster, a cylindrical, revoluble drum having a mouth opening directly into the interior of the drum and communicating with the interior of the combustion chamber of the furnace, said drum being approximately very shallow in depth but of a relatively large diameter, lifting agitators or pockets arranged around the inner periphery of the drum for carrying the coffee up and causing it to fall in a shower through the centre of the drum and through the flames and intense heat direct from the furnace, and a casing enclosing the drum, which casing is provided with a stack, substantially as described. 3rd. In a coffee roaster, the combination of a furnace having a combustion chamber of unusually large size immediately adjoining the roasting drum of said roaster, a cylindrical, revoluble roasting drum having a flaring mouth opening directly into the interior of the drum and communicating directly with the interior of the combustion chamber of the furnace, said drum being approximately very shallow in depth but of a relatively large diameter, lifting agitators or pockets arranged around the inner periphery of the drum for carrying the coffee up and causing it to fall in a shower through the centre of the drum and through the flames and intense heat direct from the furnace, additional agitators for deflecting the coffee as it falls from the lifting agitators or pockets, and a casing enclosing the drum, which casing is provided with a stack, and a damper or gate located between the furnace and the drum for cutting off communication between the same, substantially as described. 4th. In a coffee roaster, the combination of a furnace having a combustion chamber of unusually large size, a revoluble roasting drum closed to the atmosphere but open at one end for the admission of flames and heat directly from the furnace, and agitating lifters or pockets arranged around the inner periphery of the drum for carrying the coffee up, a series of agitators extending entirely across the lifting agitators in a spiral direction combining with said latter agitators to cause the coffee to fall in a shower through the centre of the drum, and a casing enclosing the drum which is provided with a stack, the construction and arrangement being such that all flame and heat passes directly from the furnace into the drum and through the falling coffee before passing out the stack in the casing, substantially as described. 5th. In a coffee roaster, the combination of a furnace, having a combustion chamber of unusually large size, a revoluble roasting drum closed to the atmosphere but open at one end for the

admission of flames and heat directly from the furnace, a series of agitating lifters or pockets arranged around the inner periphery of the drum for carrying the coffee up, a second series of agitators extending entirely across the lifting agitators in a spiral direction and a third series of agitators extending entirely across the lifting agitators or pockets but in an opposite direction to the second series, the spirally arranged agitators combining with the lifting agitators to cause the coffee to fall in a shower through the centre of the drum, a casing enclosing the drum which is provided with a stack, the construction and arrangement being such that all the flame and heat passes directly from the furnace into the drum and through the falling coffee before passing out at a stack in the casing, substantially as described. 6th. In a coffee roaster, the combination of a revoluble drum, means for admitting hot air to one end of the said drum, means for charging the said drum with coffee at the other end, discharge openings in the periphery of said drum and doors for controlling the said discharge openings, levers mounted upon one end of the drum for opening said doors, and means for actuating the said levers, substantially as described. 7th. In a coffee roaster, the combination of a revoluble drum, means for revolving the same, means for heating the drum, agitators for lifting the coffee arranged around the inner side of the periphery of the drum and forming pockets, a second series of agitators extending spirally across the first set of lifting agitators for deflecting the coffee as it falls, substantially as described. 8th. In a coffee roaster, the combination of a revoluble drum, means for heating the same, a series of agitators on the inner periphery of the drum, a second series of agitators spirally arranged across the first set of agitators, and a third set of agitators spirally arranged across the second set of agitators, but in an opposite direction to said second set, substantially as described. 9th. In a coffee roaster, the combination of a revoluble drum provided with annular bearing rings, a casing for entirely enclosing the drum from the atmosphere and provided with a stack, rollers exterior to said casing for supporting the said bearing rings and gearing secured to the end of said drum, means for revolving the same, lifting agitators or pockets arranged around the inner periphery of the drum, a second series of agitators spirally arranged across the lifting agitators or pockets, and a third series of agitators spirally arranged across the second series of agitators, but in an opposite direction to the said second series, a furnace arranged at one end of the drum for throwing flames and heat directly into the interior of the drum, and a damper interposed between the flames and the drum for regulating the supply of heat to the drum, the construction and arrangement being such that the heat and flames pass directly from the furnace into the drum through the falling coffee and out at the stack in the casing, substantially as described. 10th. In a coffee roaster, the combination of a revoluble drum provided with a discharge opening in its periphery, doors for closing said openings, means for operating the doors while the drum is revolving, a casing entirely enclosing the drum from the atmosphere, provided with a stack and formed with lower converging sides leading to a suitable discharge opening, a tray in said casing arranged over said discharge opening and a furnace adjoining the roasting drum and opening directly into the interior of the same, substantially as described. 11th. In a coffee roaster, the combination of a revoluble drum, means for supplying coffee to the same, a furnace for supplying heat to said drum, and a connecting heat pipe or chute having diverging sides leading to a discharge opening, whereby any grains of coffee thrown from the drum may be collected and prevented from entering the furnace, substantially as described. 12th. In a coffee roaster, the combination of a furnace having a combustion chamber immediately adjoining the roasting drum of said roaster, a cylindrical, revoluble roasting drum having a mouth opening directly into the interior of the drum and communicating directly with the interior of the combustion chamber of the furnace, said drum being approximately very shallow in depth, but of a relatively large diameter, and coffee agitators arranged within the drum, substantially as described.

No. 58,330. Extension Ladder. (Echelle à rallonge.)



Samuel T. Waggoner and Herbert B. Muir, both of Montreal, Quebec, Canada, 9th December, 1897; 6 years. (Filed 4th November, 1897.)

Claim.—1st. An extension ladder, comprising a stationary ladder section and a sliding ladder section, one or more pawls pivotally connected to one of said ladder sections and adapted to automatically engage the other ladder section and lock said ladder in its extended state, means for displacing said pawls, and means for extending said ladder, for the purpose set forth. 2nd. An extension ladder, comprising a stationary ladder section and a sliding ladder section, one or more pawls pivotally connected to said stationary ladder section and adapted to automatically engage the rungs of the sliding ladder section, a length of rope connected to said pawl at a point above the axis thereof, and means for extending said ladder, for the purpose set forth. 3rd. An extension ladder, comprising a stationary ladder

section and a sliding ladder section, one or more pawls pivotally connected to said stationary ladder section and adapted to automatically engage the rungs of the sliding ladder section, a length of rope connected to said pawl at a point above the axis thereof, and a length of rope connected at one end to the lowermost rung of the sliding ladder section and extending upwardly to and over a sheave carried by said stationary ladder section near the upper end thereof, and thence around the lowermost rung of the stationary ladder section to the said lowermost rung of the sliding ladder section to which the other end of said rope is connected, for the purpose set forth. 4th. In combination with the longitudinals of a ladder, a length of wire secured at one end to the front side of each longitudinal near one end thereof stretched over said adjacent end and along the full length of the rear side of said longitudinal and over the opposite end thereof, and the other end of said length of wire being secured to the said front side of the longitudinal near the opposite end thereof, for the purpose set forth. 5th. An extension ladder, comprising a stationary ladder section and a sliding ladder section, a length of wire secured at one end to the front side of each of the longitudinals of said ladder sections near one end thereof, said length of wire being stretched over said adjacent end and along the full length of the rear side of said longitudinal and over the opposite end thereof, and the other end of said length of wire being secured to the said front side of the longitudinal near the opposite end thereof, one or more pawls pivotally connected to one of said ladder sections and adapted to automatically engage the other ladder section and lock said ladder in its extended state, means for displacing said pawls and means for extending said ladder, for the purpose set forth.

No. 58,331. Sole. (Semelle.)

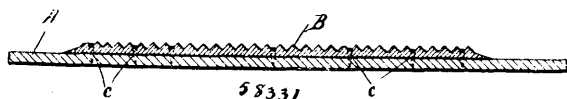

Jean B. I. Prefontaine, South Durham, Quebec, Canada, assignee of Edward E. Carll, Portsmouth, New Hampshire, U.S.A., 9th December, 1897; 6 years. (Filed 12th November, 1897.)

Claim.—The combination, with a shoe sole, of a diamond-shaped pad of elastic material provided with an indented undersurface, and means for securing the said pad to the shoe sole, substantially as set forth.

No. 58,332. Nut Lock. (Arrête-écrou.)

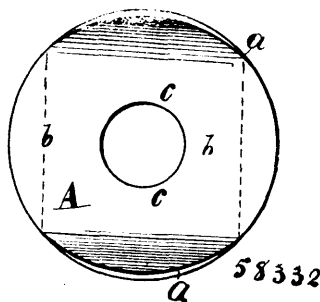

Monroe White, Guy Macgowan, and Robert B. Ellis, all of Vancouver, British Columbia, Canada, 9th December, 1897; 6 years. (Filed 18th November, 1897.)

Claim.—1st. In a nut-lock, a circular plate of steel having its portion adjacent to its axis on a level plane, and its opposite sides deflected from the level plane, as specified. 2nd. In a nut-lock, a plate of steel with its opposite side edges deflected from the level plane, so that when a nut is tightened down thereon bulges will be formed on the outer two opposite sides of a nut and made to engage the corners thereof, substantially as and for the purposes hereinbefore set forth.

No. 58,333. Cycle Propelling and Braking Mechanism. (Mécanisme de propulsion et frein de bicyclettes.)

Gerard Beekman, New York, State of New York, U.S.A., 10th December, 1897; 6 years. (Filed 28th October, 1897.)

Claim.—1st. In a cycle, the combination with a suitable supporting frame and a rotary driven element mounted therein, of two oppositely disposed pedal cranks mounted within said driven element upon shaft sections having a limited rotative and longitudinal movement relative to each other, mechanism for converting the opposed rotative movement of said shaft sections in either relative direction from a normal intermediate position into an opposed longitudinal movement thereof in one given direction, and frictional contact portions or surfaces upon said shaft sections adapted to engage with frictional contact surfaces upon said driven element by said opposed longitudinal movement of the sections, and elastic means tending to resist said opposed movements and to maintain the cranks in their normal opposite relation. 2nd. In a cycle, the combination with a crank shaft hanger box having ball bearings at each

extremity, of a driven shaft rotative in said bearings and carrying a sprocket wheel or other motion transmitting device located beyond

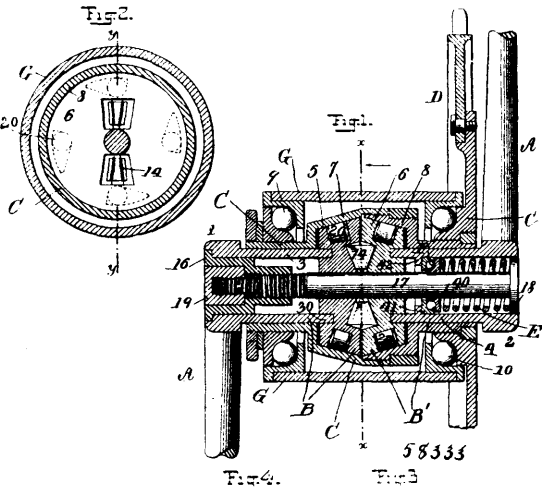

the extremity of the hanger box, and two cranks immediately outside the extremities of the driven shaft and having a limited rotative movement with relation to each other, clutch mechanism located between said ball bearings and enclosed within said hanger box, and means whereby said clutch mechanism is engaged and disengaged with the driven shaft by the said relative movement of the cranks to communicate motion from the driving to the driven shaft. 3rd. In a cycle, the combination with a crank hanger, and a rotary tubular driven shaft therein, of two oppositely disposed pedal cranks mounted upon shaft sections extending within the tubular shaft and having a limited rotative and longitudinal movement relative to each other, mechanism for converting the opposed rotative movement of said shaft sections in either relative directions from a normal intermediate position into an opposed longitudinal movement thereof in one given direction located between the adjacent inner ends of said shaft sections, tapered frictional contact surfaces upon said shaft sections caused to engage with tapered frictional contact surfaces within said driven shaft by said opposed longitudinal movement of the sections, and springs, and means for confining them with inward longitudinal pressure against said shaft sections. 4th. In a cycle, the combination with a crank hanger and a rotary tubular driven shaft therein, of two oppositely disposed pedal cranks mounted upon shaft sections extending within the tubular shaft and having a limited rotative and longitudinal movement relative to each other, mechanism for converting the opposed rotative movement of said shaft sections in either relative direction from a normal intermediate position into an opposed longitudinal movement thereof in one given direction located between the adjacent ends of said shaft sections, tapered frictional contact surfaces upon said shaft sections caused to engage with tapered frictional contact surfaces within said driven shaft by said opposed longitudinal movement of the sections, and a spring, and means for confining the same with longitudinal pressure against said shaft sections, and a positive clutch mechanism consisting in rollers located in inclined pockets and interposed between said sections and said driven shaft adapted to engage for a given direction of rotation. 5th. In a cycle, the combination with a friction clutch having its members respectively connected with the driving and driven elements, of a positive clutch consisting in rollers or balls arranged to act in seats inclined in a given direction with reference to rotation and located between the friction faces of the said clutch. 6th. In a cycle, the combination with a friction clutch having its members respectively connected with the driving and driven elements, of rotary pedal cranks having a limited relative movement to actuate said clutch, a spring tending to maintain said cranks in opposite positions, and means for rendering said spring so operative by pressure in opposite directions upon the crank hubs, and a roller or ball bearing surrounding said axis and interposed to receive the pressure of said spring and relieve the cranks from friction in their said relative movement. 7th. In a cycle, the combination with a crank shaft hanger of a clutch mechanism contained within said hanger for engaging the driving and driven elements, consisting in a hollow rotary driven member, having inwardly facing tapered friction shoulders, and a drive shaft having two longitudinally movable hollow sections provided with outwardly facing tapered friction shoulders and with formations adapted to separate said sections by a rotary movement with respect to one another, pedal cranks removably connected with said sections, and a cross-tie bolt, and an adjustable spring or springs thereon interposed between the shoulders of said bolt and said sections bearing inwardly upon the crank hubs tending to press them together, and release the frictional contact of said shoulders, said cross-tie bolt adapted simultaneously to secure in position said pedal cranks and sections and adjust the tension of said spring or springs.

No. 58,334. Bicycle Support. (Support de bicycles.)

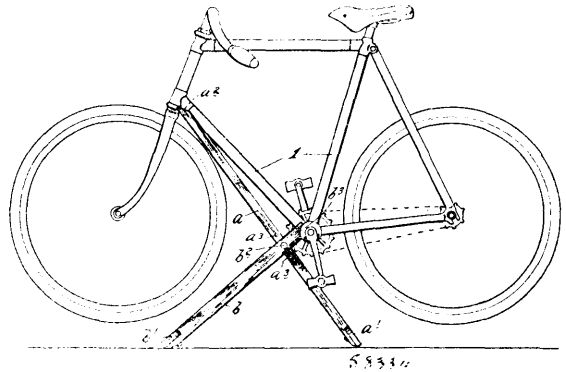

William A. Mather and Frederick J. Clark, assignees of Thomas Libby, all of Minneapolis, Minnesota, U.S.A., 10th December, 1897; 6 years. (Filed 23rd October, 1897.)

Claim.—1st. A bicycle support adapted to be straddled lengthwise by the bicycle frame, and affording two points of support therefor, to wit, one at or near the junction of the steering-head and the bottom stay and the other at or near the crank shaft hanger, whereby the machine is held right side up, solely from the frame, and all the running parts are free to turn, substantially as described. 2nd. A bicycle support adapted to be straddled lengthwise by the bicycle frame, and composed of two convergent legs pivoted together at their junction and affording two points of support for the bicycle frame, to wit, one at or near the junction of the steering-head and bottom stay and the other at or near the crank shaft hanger, whereby the spread of the support is limited by the machine frame and the machine is held right side up, with all its running parts free to turn, substantially as described. 3rd. A bicycle support adapted to be straddled lengthwise by the bicycle frame, and composed of two convergent legs pivoted together at their junction and affording two points of support for the bicycle frame, to wit, one at or near the junction of the steering-head and bottom stay and the other at or near the crank shaft hanger, with said support constructed not only to uphold the machine but to prevent the steering-fork from turning, substantially as described. 4th. A bicycle support adapted to be straddled lengthwise by the bicycle frame and composed of two convergent legs pivoted together at their junction, with the rear or long member extended upward beyond the pivot and provided with a notch for engaging in the jaw of the frame formed by the bottom stay and the steering-head, substantially as and for the purposes set forth. 5th. A bicycle support adapted to be straddled lengthwise by the bicycle frame, composed of two convergent legs pivoted together at their junction, and both extended upward beyond their pivot pins, and provided one with a notch to engage the jaw of the frame formed by the bottom stay and the steering-head, and the other with seats for receiving the crank shaft hanger, substantially as and for the purposes set forth.

No. 58,335. Bicycle Saddle. (Selle de bicycles.)

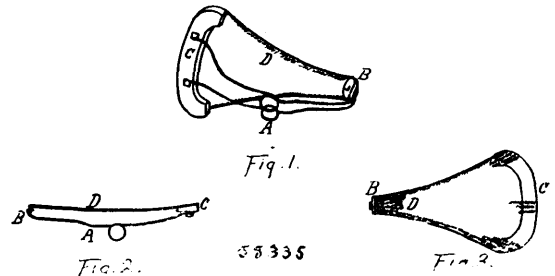

Thomas Bassford, St. Thomas, Ontario, Canada 10th December, 1897; 6 years. (Filed 26th November, 1897.)

Claim.—1st. The combination in a bicycle saddle with the pommel and holster-tree, of a spirally woven wire web under tension, substantially as and for the purpose hereinbefore set forth. 2nd. In a bicycle saddle, the combination with the pommel and holster-tree of lateral wires having spiral springs attached thereto or constructed therewith, substantially as and for the purpose hereinbefore set forth. 3rd. The combination with lateral wires attached to the pommel and holster-tree of a web, lacing or fabric covering the said wires or interwoven therewith, substantially as and for the purpose hereinbefore set forth.

No. 58,336. Vehicle Wheel. (Roue de voitures.)

Charles F. Church, Newark, New Jersey, U.S.A., 10th December, 1897; 6 years. (Filed 28th October, 1897.)

Claim.—1st. As an improved article of manufacture, a wheel rim consisting of a wooden base and a covering layer of cellu-

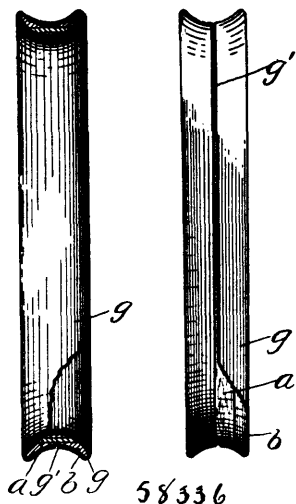

loid or like material moulded and formed thereon and intimately united thereto, all substantially as described. 2nd. As an improved article of manufacture, a wheel rim with a covering layer of celluloid or like material cemented thereto, moulded thereon and intimately united therewith, all substantially as described. 3rd. As an improved article of manufacture, a wooden wheel rim with a covering layer of celluloid or like material cemented thereto, moulded thereon and intimately united therewith, all substantially as described. 4th. As an improved article of manufacture, a laminated wooden wheel rim, a covering layer of celluloid cemented thereto, firmly moulded upon and intimately united with the surface of the rim as by the application of heat and pressure, all substantially as described. 5th. As an improved article of manufacture, a wooden rim for a bicycle wheel having a concave face, a layer of celluloid cemented to, formed upon and intimately united with the back and sides of the rim, leaving the central portion of the concave face of the rim uncovered, and a tire secured in the socket in the rim, all substantially as described. 6th. As an improved article of manufacture, a wheel rim with a covering layer of celluloid or like material moulded thereon and intimately united therewith, all substantially as described.

No. 58,337. Vehicle Frame. (Bati pour bicycles.)

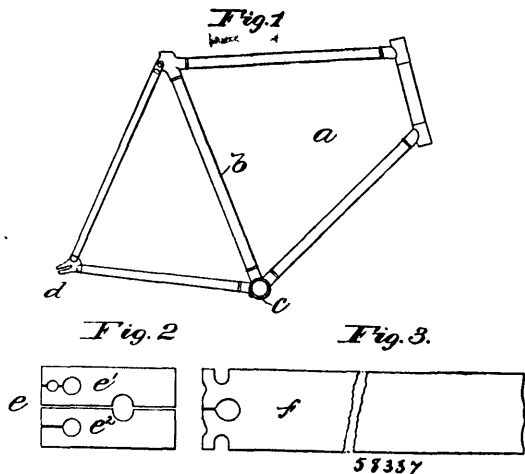

Charles F. Church, Newark, New Jersey, U.S.A., 10th December, 1897; 6 years. (Filed 3rd November, 1897.)

Claim.—1st. As an improved article of manufacture, a vehicle frame, component part thereof or attachment thereto having a foundation of metal or wood, and a thin covering layer of celluloid or like material formed upon and moulded to the part and intimately united to its surface by the application of heat and pressure, all substantially as described. 2nd. As an improved article of manufacture, a vehicle frame of metal or wood having a thin covering layer of celluloid or like material formed upon, cemented and

moulded to the frame parts and intimately united to the surface thereof by the application of heat and pressure thereto, all substantially as described. 3rd. As an improved article of manufacture, a vehicle frame consisting of separable main and bracket members, means for mechanically securing the frame parts together, and the said frame parts having a thin covering layer of celluloid or like material formed upon and moulded to the parts and intimately united to the surface of such parts by the application of heat and pressure, all substantially as described.

No. 58,338. Pump for Pneumatic Tires. (Pompe pour bandages pneumatiques.)

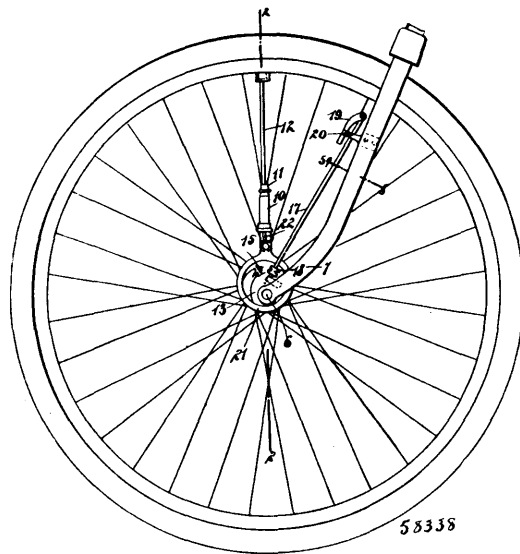

Allouson S. Simpson, Folsom, New Mexico, U.S.A., 10th December, 1897; 6 years. (Filed 3rd November, 1897.)

Claim.—1st. The combination of a frame, an axle held thereby, a wheel turning loose on the axle, a cylinder carried by the wheel, a piston working in the cylinder, a rod attached to the piston, an eccentric loose on the axle and having a lug, a strap embracing the eccentric and connected with the rod of the piston, a shaft rocking in the frame, and a dog carried by the shaft and capable of engaging the lug whereby to stop the revolution of the eccentric. 2nd. The combination of a shaft, an eccentric loose thereon, the eccentric having a lug provided with two recesses and the face of the eccentric having an inclined way running up to the lug, a shaft rockably held by the frame, and a dog carried by the shaft and having two fingers capable of respectively engaging in the recesses of the lug. 3rd. The combination of a shaft, an eccentric loose on said shaft, a strap turning around the shaft and co-acting with the eccentric, a rock shaft mounted adjacent to the eccentric, and a dog carried on the rock shaft and movable to engage and disengage the eccentric whereby to hold the same fixed with reference to the shaft.

No. 58,339. Ball and Roller Gearing. (Engrenage à boules.)

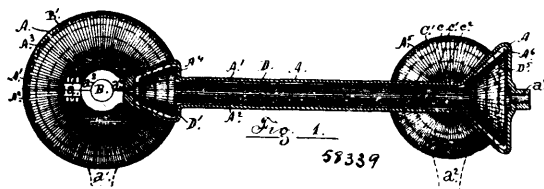

Henry B. Keiper, Lancaster, Pennsylvania, U.S.A., 10th December, 1897; 6 years. (Filed 4th November, 1897.)

Claim.—1st. A device for transmitting rotary motion comprising the following instrumentalities: rotatable shafts, having ends in adjacent pairs, mounted at angles with reference to each other; wheels having contacting faces and edges provided with circular recesses and secured, in pairs, near said adjacent ends to said shafts; balls loosely seated in the recesses of the one, in each pair, of said wheels, with means provided, such as the shell with the ridges a^3 and the edges a^7 to confine said balls thereto; and a casing, provided to house said shafts and wheels, all substantially as and for the purpose hereinbefore set forth. 2nd. In a device for transmitting rotary motion, in combination, shafts; rotatably mounted at

angles with reference to each other and having their extremities in adjacent pairs journalled at each of said angles; wheels with contacting edges and faces, secured in pairs, near said extremities, to said shafts, and having registering circular recesses in said contacting faces and edges, balls loosely seated in the recesses of one of each pair of said wheels, and a shell with projecting edges to confine the ball thereto; and a casing, provided to house said shafts and wheels, all substantially as described and for the purpose hereinbefore set forth. 3rd. In a device for transmitting rotary motion in angular directions, in combination, shafts rotatably journalled with their extremities in pairs at each angle of direction; wheels with contacting faces and edges secured in pairs, near said extremities, to said shafts and having registering recesses in said faces and edges; balls loosely seated in the recesses of one of each pair of said wheels, and an independent shell with projecting edges and guide way ridges surrounding the wheels to confine the balls thereto, all substantially as described and for the purpose hereinbefore set forth. 4th. Gearing comprising members between which motion is to be transmitted, said members having registering sockets, rollers seating loosely in the sockets of one member and projecting therefrom for engagement with the sockets of the other member, and a casing extending over the socketed surface of the roller-carrying member confining the rollers to the sockets thereof and excluding them from the sockets of the other member except when transmitting motion between the members, substantially as and for the purpose hereinbefore set forth. 5th. Gearing comprising wheels associated together and having registering sockets, rollers loosely seated in the sockets of one wheel and adapted to engage the sockets of the other wheel to transmit motion, and a shell or casing embracing the roller-carrying wheel to confine the rollers in the sockets thereof, and extending in such close proximity to the socket surface of the other wheel as to exclude the rollers from the sockets thereof, except when transmitting motion between the wheels, substantially as described and for the purpose hereinbefore set forth. 6th. Bevel gearing comprising members having registering sockets arranged in a plurality of circular series, rollers seating loosely in the sockets of one member and projecting therefrom for engagement with the sockets of the other member for transmitting motion, and a casing surrounding the roller-carrying member and confining the roller-bodies in the sockets thereof and excluding them from the casing having ridges between the series of roller-bodies, all substantially as described and for the purpose hereinbefore set forth. 7th. Mitre gearing comprising members having registering sockets or recesses arranged in a plurality of concentric circles and at staggered distances apart, rollers seating loosely in the sockets of one member and projecting therefrom for engagement with the sockets of the other member to transmit motion, and a casing surrounding the roller-carrying member and confining the roller-bodies in the sockets thereof and having projecting edges excluding said rollers from the sockets of the other member except when transmitting motion, with ridges between the several series of roller-bodies, all substantially as described and for the purpose hereinbefore set forth.

No. 58,340. Bicycle Grip. (Poignée de bicyclet.)

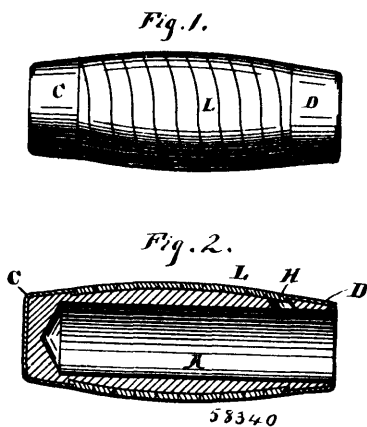

Alexander Dodds and Burt W. Fish, both of Grand Rapids, Michigan, U.S.A., 10th December, 1897; 6 years. (Filed 5th November, 1897.)

Claim.—1st. In a bicycle grip, the combination of a core as A, provided with enlarged ends forming shoulders as B B, a leather covering as L, a cap as C, enclosing one end of the core and extending over a portion of the leather covering so as to secure the same in place, and a ferrule surrounding the other end of the wooden core and extending over a portion of the leather covering for the purpose of retaining the same in place, said leather covering being secured also to the core by means of glue or other suitable material, substantially as described. 2nd. In combination with a core as A, having enlarged ends forming shoulders as B B, a leather or other

suitable covering, a hole as H, receiving one end of the covering strip, said hole being placed beneath the ferrule D, a ferrule D extending over a portion of the leather covering, and a cap C at the other end of the wooden core extending over a portion of the leather strip, thereby securing the leather strip at either end of the core, substantially as described. 3rd. In combination with a wooden core, a leather strip wound thereon, said winding being in the form of a coil, a cap covering one end of the wooden core and a portion of the leather strip, and a ferrule surrounding the other end of the wooden core and extending over a portion of the leather strip, all constructed substantially as and for the purpose described.

No. 58,341. Vehicle Tire. (Bandage de roue.)

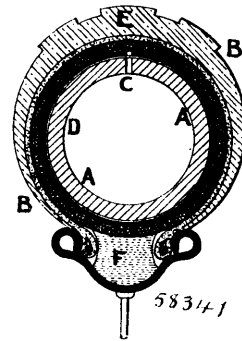

Charles Henry Greaves and George Greaves, both of Craven House, Gomersal, Leeds, England, 10th December, 1897; 6 years. (Filed 6th November, 1897.)

Claim.—1st. Pneumatic tires composed of hollow india-rubber balls or sections secured around the periphery of the wheel by a cover, each ball or section having a breathing or air hole therein and is so made that after compression, it quickly regains its original shape for the purposes shown and described. 2nd. The construction of balls or sections forming the pneumatic tire of wheels, each ball or section having a breathing or air hole therein, and having a knitted, crewelled, or woven cover of tough fibrous material, substantially as shown and described. 3rd. The construction of balls or sections forming the pneumatic tire of wheels, each ball or section having a breathing or air hole therein, and having an india-rubber or elastic cover fixed on in a stretched state, and a further woven, knitted or crewelled cover of fibrous material, substantially as shown and described.

No. 58,342. Ball-Bearings. (Coussinet à boule.)

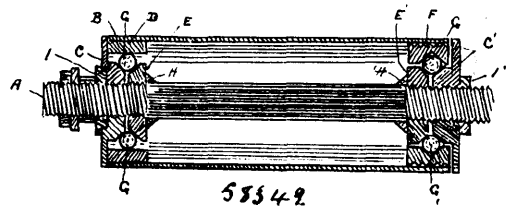

Robert O. Blayney, Brantford, Ontario, Canada, 10th December, 1897; 6 years. (Filed 10th November, 1897.)

Claim.—1st. In a ball-bearing, the combination of a shaft, a cylindrical casing two series of balls, one of which run on a three point bearing track formed by a plain ring and two cone-faced sleeves, the other series of balls running on a four point-bearing track, formed by a ring with a V groove, and two cone-faced sleeves composing another V, forming an inner and an outer track, substantially as described. 2nd. In a ball-bearing, the combination of a shaft, two series of balls, a three point-bearing track at one end, and a four point-bearing track at the other end of shaft, and casing with the outer end, cone-faced rings or sleeves adjustable by screw-threads with lock-nuts, as described.

No. 58,343. Bicycle. (Bicycle.)

James E. Wilson, Bridgeport, Connecticut, U.S.A., 10th December, 1897; 6 years. (Filed 15th November, 1897.)

Claim.—1st. In a bicycle, the combination of the rear fork, with the yoke lever pivoted in close proximity to its rear extremity to the end of said fork and inside the latter, the rear wheel journalled in the rear end of said lever immediately beyond the pivotal point thereof, the forward extremity of said lever extending within the bicycle frame and around the forward portion of the rear wheel, and the spring element connected to said frame and to the forward end of said lever whereby the latter is rendered resilient, substan-

tially as set forth. 2nd. In a bicycle, the rear fork of the frame supported on a swinging or tilting yoke lever in close proximity to

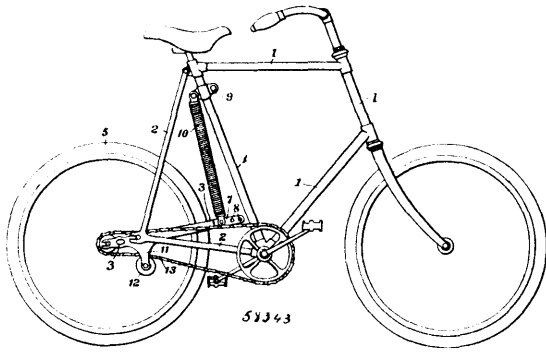

the rear end thereof, the rear or forked end of said lever fulcrumed on the axle of the rear wheel, the forward or loop end of said lever extending forward within the frame and surrounding the forward portion of the wheel, and a spring or equivalent resilient element supporting said lever, substantially as set forth.

No. 58,344. Bicycle Support. (Support de bicycles.)

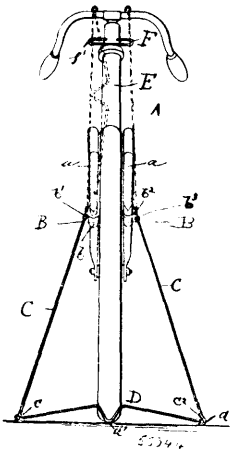

Martha J. Guthrie, Wichita, Kansas, U.S.A., 10th December, 1897; 6 years. (Filed 15th November, 1897.)

Claim.—1st. In a bicycle support, a bicycle, clamps secured to the front forks thereof, supporting arms pivotally secured to the clamps at their upper ends, and a base rod pivotally secured to one of the supporting arms at one end, detachably secured to the opposite arm at the opposite end, substantially as described. 2nd. In a bicycle support, a bicycle, a support pivotally secured thereto, means for folding the support together and a clamp upon the bicycle for securing the support when folded, substantially as described.

No. 58,345. Bicycle Support. (Support de bicycles.)

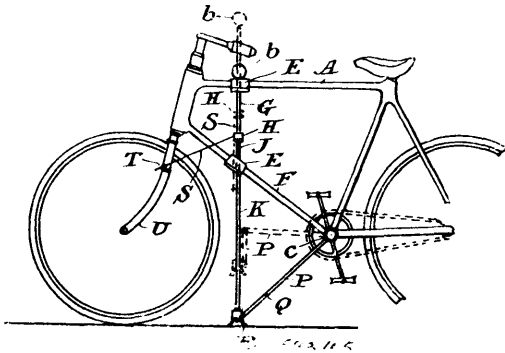

Joseph F. Furley, North Sydney, and Ebenezer Forsyth, Willoughby, both in New South Wales, Australia, 10th December, 1897; 6 years. (Filed 29th November, 1897.)

Claim.—1st. In a bicycle support, a vertical centre rod or leg as G, passing through a head piece, connected to two legs as K K, said legs having hinged connections at or near the lower ends of same to

the centre rod or leg, adapted to be so operated that a downward or upward and outward or inward movement, may be imparted to legs K K by the centre rod or leg G, substantially as herein described, explained and illustrated in the drawings. 2nd. A bicycle support with a vertical rod or centre leg, passing through vertically secured sleeves, and a head piece as H, having hinged thereto the outer legs K K, connected at or near their lower ends with the vertical rod or centre leg, the downward movement of same being regulated by a spiral spring placed around a part of the vertical rod or centre leg, between one of the vertical sleeves and the head piece, the said vertical rod or centre leg being governed in its downward passage by a collar, placed above the head piece substantially as herein described, explained and illustrated in the drawings. 3rd. In a bicycle support, a vertical rod or centre leg as G, passing through a head piece as H, with the legs K K, hinged thereto, and provided with hinged connections to the vertical rod or centre leg, at or near their lower ends, a jointed back stay as P, loosely connected with the crank bracket at one end, the other end being hinged at or near the lower end of the rod or centre leg, substantially as herein described, explained and illustrated in the drawings. 4th. A bicycle support having a vertical rod or centre leg as G, passing through a head piece as H, with the legs K K, hinged thereto, a light rod as S, hinged to the head piece H, adapted to be received in a grooved attachment secured to the front fork, for the purpose of locking the pilot wheel and preventing the same swinging, substantially as herein described, explained and illustrated in the drawings. 5th. A bicycle support having a vertical rod or centre leg as G, passing through sleeves as E E, and a head piece as H, the latter having legs K K, hinged thereto, and the said legs having hinged connections at or near their lower ends with the rod or centre leg, an automatic locking bar as W, adapted to engage with slots or openings provided in the vertical rod or centre leg, so as to retain the support in various positions, substantially as herein described, explained and illustrated in the drawings. 6th. A bicycle support having a vertical rod or centre leg as G, passing through sleeves as E E, and a head piece as H, the latter having legs K K, hinged thereto, and the said legs having hinged connections at or near their lower ends, with the rod or centre leg, a loop or cup on one of the said legs adapted to support an umbrella, rifle or the like, substantially as herein described, explained and illustrated in the drawings. 7th. The combination and arrangement of the various parts herein described, explained and illustrated, altogether forming the improved bicycle support, substantially and for the purposes set forth.

No. 58,346. Velocipede Saddle. (Selle de vélocipèdes.)

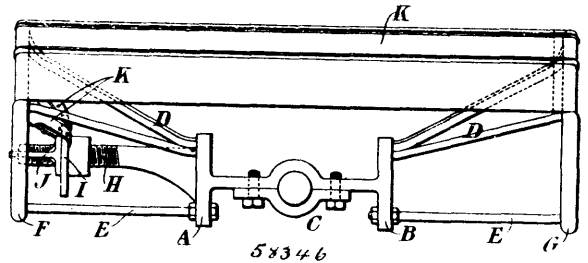

The Earl of Dundonald, 34 Portman Square, London, England, 10th December, 1897; 6 years. (Filed 1st December, 1897.)

Claim.—A yielding seat consisting of straps or fabric strained over semicircular ring frames, substantially as described.

No. 58,347. Cycle Driving Mechanism. (Mécanisme d'engrenage de cycles.)

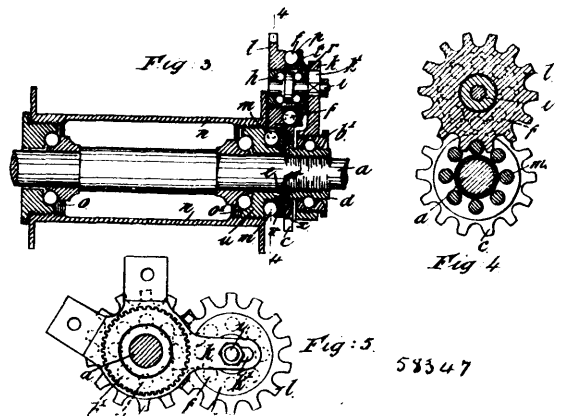

John H. Howe, 71 Cathedral Square, Christchurch, New Zealand, 10th December, 1897; 6 years. (Filed 28th October, 1897.)

Claim.—1st. In combination, a spindle having cranks at each end and carrying a spur-wheel gearing with a pinion having balls in the place of fixed teeth, said pinion being fixed to a spur-wheel gearing with another pinion having ball teeth fixed upon the hub of the driving-wheel of a cycle, substantially as specified. 2nd. The combination in a train of gear-wheels employed in cycle driving-gear for communicating motion from the crank-spindle to the driving-wheel, of a wheel having balls around its periphery, said balls forming teeth of the wheel and being carried in corresponding recesses formed in the two parts of which the wheel is constructed, substantially as and for the purposes herein described. 3rd. The combination in a train of wheels employed in driving-gear for communicating motion from the crank-spindle to the driving wheel of a cycle, a wheel having balls forming gear-teeth, said wheel being in two parts similarly recessed to receive the balls, one of the said parts being fixed upon a spindle and the other being in form of a washer fitted over the spindle, and held in position by a screw nut and set pin, substantially as specified.

No. 58,348. Bicycle Seat Post.

(*Pilier pour selles de bicycles.*)

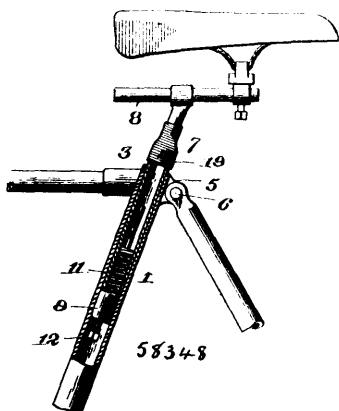

Alfred Johnson, Philadelphia, Pennsylvania, U.S.A., 10th December, 1897; 6 years. (Filed 30th July, 1897.)

Claim.—1st. The combination with a saddle post of mechanism designed to yieldingly support the same, tension-regulating mechanism, and a protector slidingly mounted on the upper end of the saddle post, substantially as and for the purpose specified. 2nd. The combination with the seat post tube of a saddle post formed of two telescoping sections, a spring upon which the lower end of the lowermost section rests, a transverse stop-pin for limiting the movement of one of the said sections, and a protector slidingly mounted upon one of said sections to protect the hands against contact with the lubricant, substantially as shown and described. 3rd. The combination with the seat post tube of the T-post formed hollow and having a closing disc, the hollow section with closed end, the stop-pin passed through the inner section and into slots in the outer section, a spring upon which the lower end of the lower section rests, and a tension-regulating device, and a saddle mounted upon the horizontal portion of the T-post, substantially as shown and described.

No. 58,349. Bicycle Gearing. (*Engrenage de bicycles.*)

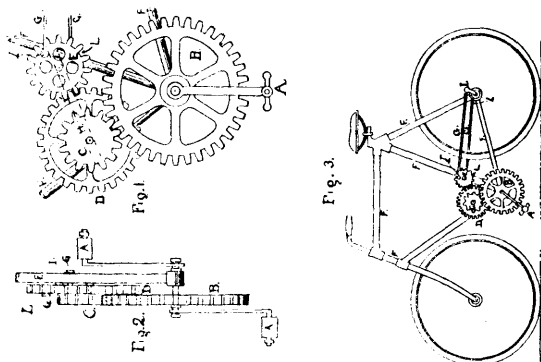

Carl C. Schmidt, Saint John, New Brunswick, Canada, 10th December, 1897; 6 years. (Filed 14th September, 1897.)

Claim.—The attachment by rods from the wheel E to I, the termination of cranks L attached to the axle of the rear wheel of the bicycle, by which the use of a chain is done away with.

No. 58,350. Bicycle. (*Bicycle.*)

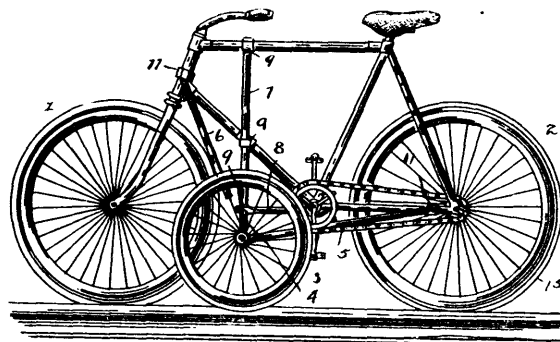

58350

William P. Brodbeck, Gallatin, Missouri, U.S.A., 11th December, 1897; 6 years. (Filed 2nd December, 1897.)

Claim.—1st. The combination with the frame of a bicycle, of an attachment consisting of an upright post, removably secured to the frame of a bicycle, a lateral arm 4 secured to said post, and provided at its free end with a wheel, and brace rods 5 and 6 secured at their outer ends to the outer end portions of said arm and removably secured at their inner ends to the frame of the bicycle or as shown in fig. 2, of the lateral arm 4 extending from 9 on top bar of the bicycle at a suitable angle downward to the point of break in 4 from whence it extends on a bevel outward to wheel 3, substantially as described. 2nd. The fastening in any way of a single or double flange or flanges to the rim or tire of a pneumatic wheel whereby it is kept upon a track.

No. 58,351. Wheel Tire. (*Bandage de roue.*)

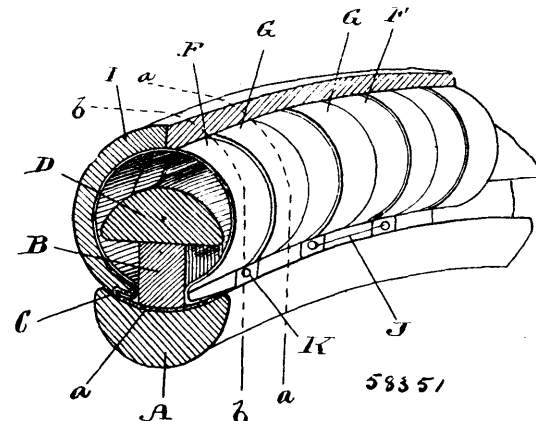

58351

Edward J. Chambers, Woodstock, Ontario, Canada, 11th December, 1897; 6 years. (Filed 3rd December, 1897.)

Claim.—1st. In a wheel the combination of a felloe, having a central flange projecting radially from its perimeter, and a tire consisting of a plurality of independent annular sections held in position by the compression of their opposite meeting edges against the sides of the radial flange, substantially as specified. 2nd. In a wheel the combination of a felloe, having a central flange projecting radially from its perimeter, and a tire consisting of a plurality of independent annular sections held in position by the compression of their opposite meeting edges against the sides of the radial flange, an apron connected to the felloe extending beyond the sides of the flange to protect the opposite meeting edges of the tire sections, substantially as specified. 3rd. In a wheel the combination of a felloe, having a central flange projecting radially from its perimeter, a tire consisting of a plurality of independent annular sections held in position by the compression of their opposite meeting edges against the sides of the radial flange, an apron connected to the felloe extending beyond the sides of the flange to protect the opposite meeting edges of the tire sections, and a tubular cover to enclose the tire sections, apron, and flange, substantially as specified. 4th. In a wheel the combination of a felloe, having a central flange projecting radially from its perimeter, a tire consisting of a plurality of independent annular sections held in position by the compression of their opposite meeting edges against the sides of the radial flange, and a buffer connected to the perimeter of the flange and overhanging its sides to assist in preventing the displacement of the tire sections, and to assist in protecting them against breakage by compression, substantially as specified. 5th. In a wheel the combination of a felloe, having a central flange projecting radially from its perimeter, a tire consisting of a plurality of independent annular sections held in position by the compression of their opposite meet-

ing edges against the side of the radial flange, an apron connected to the felloe extending beyond the sides of the flange to protect the opposite meeting edges of the tire sections, and a buffer connected to the perimeter of the flange and overhanging its sides to assist in preventing the displacement of the tire sections, and to assist in protecting them against breakage by compression, substantially as specified. 6th. In a wheel the combination of a felloe, having a central flange projecting radially from its perimeter, a tire consisting of a plurality of independent annular sections held in position by the compression of their opposite meeting edges against the sides of the radial flange, an apron connected to the felloe extending beyond the sides of the flange to protect the opposite meeting edges of the tire sections, a tubular cover to enclose the tire sections, apron, and flange, and a buffer connected to the perimeter of the flange and overhanging its sides to assist in preventing the displacement of the tire sections, and to assist in protecting them against breakage by compression, substantially as specified. 7th. In a wheel the combination of a felloe, having a central flange projecting radially from its perimeter, a tire consisting of a plurality of independent annular sections held in position by the compression of their opposite meeting edges against the sides of the radial flange, a plurality of shields to protect the joints of the tire sections, consisting of a semi-divided annular plate to embrace two adjacent tire sections, and a clip connected to the inner side of the annular plate to embrace the inner faces of two adjacent tire sections, substantially as specified. 8th. In a wheel the combination of a felloe, having a central flange projecting radially from its perimeter, a tire consisting of a plurality of independent annular sections held in position by the compression of their opposite meeting edges against the sides of the radial flange, an apron connected to the felloe extending beyond the sides of the flange to protect the opposite meeting edges of the tire sections, a plurality of shields to protect the joints of the tire sections, consisting of a semi-divided annular plate to embrace the adjacent tire sections, and a clip connected to the inner side of the annular plate to embrace the inner faces of two adjacent tire sections, substantially as specified. 9th. In a wheel the combination of a felloe, having a central flange projecting radially from its perimeter, a tire consisting of a plurality of independent annular sections held in position by the compression of their opposite meeting edges against the sides of the radial flange, an apron connected to the felloe extending beyond the sides of the flange to protect the opposite meeting edges of the tire sections, a tubular cover to enclose the tire sections, apron, and flange, a plurality of shields to protect the joints of the tire sections, consisting of a semi-divided annular plate to embrace the adjacent tire sections, and a clip connected to the inner side of the annular plate to embrace the inner faces of two adjacent tire sections, substantially as specified. 10th. In a wheel the combination of a felloe, having a central flange projecting radially from its perimeter, a tire consisting of a plurality of independent annular sections held in position by the compression of their opposite meeting edges against the sides of the radial flange, a buffer connected to the perimeter of the flange and overhanging its sides to assist in preventing the displacement of the tire sections, and to assist in protecting them against breakage by compression, a plurality of shields to protect the joints of the tire sections, consisting of a semi-divided annular plate to embrace the adjacent tire sections, and a clip connected to the inner side of the annular plate to embrace the inner faces of two adjacent tire sections, substantially as specified. 11th. In a wheel the combination of a felloe, having a central flange projecting radially from its perimeter, a tire consisting of a plurality of independent annular sections held in position by the compression of their opposite meeting edges against the sides of the radial flange, an apron connected to the felloe extending beyond the sides of the flange to protect the opposite meeting edges of the tire sections, a buffer connected to the perimeter of the flange and overhanging its sides to assist in preventing the displacement of the tire sections, and to assist in protecting them against breakage by compression, a plurality of shields to protect the joints of the tire sections, consisting of a semi-divided annular plate to embrace two adjacent tire sections, and a clip connected to the inner side of the annular plate to embrace the inner faces of two adjacent tire sections, substantially as specified. 12th. In a wheel the combination of a felloe, having a central flange projecting radially from its perimeter, a tire consisting of a plurality of independent annular sections held in position by the compression of their opposite meeting edges against the sides of the radial flange, an apron connected to the felloe extending beyond the sides of the flange to protect the opposite meeting edges of the tire sections, a tubular cover to enclose the tire sections, apron, and flange, and a buffer connected to the perimeter of the flange and overhanging its sides to assist in preventing the displacement of the tire sections, and to assist in protecting them against breakage by compression, a plurality of shields to protect the joints of the tire sections, consisting of a semi-divided annular plate to embrace two adjacent tire sections, and a clip connected to the inner side of the annular plate to embrace the inner faces of two adjacent tire sections, substantially as specified.

No. 58,352. Air Pump. (Pompe à air.)

Harold R. Goodwin, Sudbury, Middlesex, England, 11th December, 1897; 6 years. (File 19th November, 1897.)

Claim.—1st. A pump accessory consisting of a rest or support adapted at its lower end to rest and be held upon the ground and at

its upper end to be applied in a readily detachable manner to the delivery end of the stationary part of an ordinary air pump, so as to

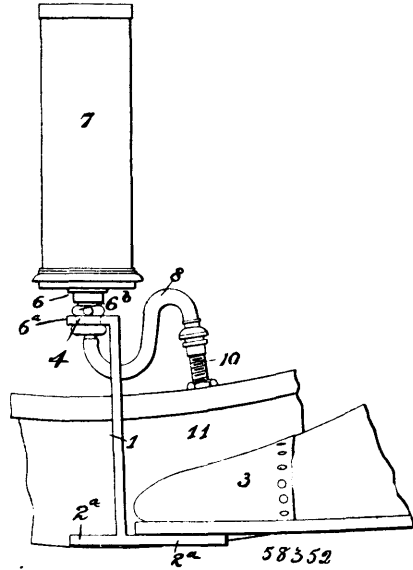

support and hold the same above the ground during each stroke of the pump and permit of the passage of the flexible and axial or central air delivery pipe used to connect such pump part to the air valve of a pneumatic tire, and of being afterwards readily detached from said stationary part of the pump, substantially as described. 2nd. A pump accessory comprising a rest or support having a foot or base whereby it can be held upon the ground by the foot of the pump operator and a slotted upper part open at one side whereby it can be engaged with the delivery end of the stationary part of an air pump provided with a central or axially arranged air delivery outlet and flexible air tube after such tube has been connected to the air valve of a pneumatic tire so as to support the said pump part and air delivery outlet above the ground, substantially as described. 3rd. A pump accessory consisting of a rest or support adapted to be held upon the ground by the foot of the user and provided at its upper end with a clip device whereby it can be sprung onto the normally fixed part of an air pump, so as to support such pump part and the flexible air tube extending therefrom above the ground. 4th. A pump accessory comprising a rest or support adapted to be held upon the ground and having at its upper end a spring clip device consisting of a pair of circularly bent spring arms adapted to clamp around and hold the stationary part of an air pump barrel, substantially as herein described. 5th. A pump accessory comprising a rest or support, the upper end of which is formed with vertical and horizontal slots to adapt it to be engaged by a lateral movement with horizontal projections on the normally fixed part of an air pump and to support such pump part above the ground, and to be disengaged from said pump part by a reverse movement, and a foot piece attached to the lower end of said rest or support and whereby the same can be held upon the ground, substantially as described. 6th. A pump rest comprising a support having a vertically and horizontally slotted upper end adapted to be applied to and disengaged from an air pump by a lateral movement of the one part toward the other end to grip the pump part with a spring action, and a foot piece at the lower end of said support whereby the same can be held upon the ground, as and for the purposes set forth. 7th. A pump accessory comprising a bar or support having at its lower end a foot or base by which it can be held upon the ground, and at its upper end one or more lateral extensions formed or each formed with a slot or recess open at one end, substantially as described for the purpose specified. 8th. A pump accessory comprising a bar or support provided at its ends with lateral extensions, one of which is movable relatively to the bar or support and is capable of being held upon the ground to hold said bar or support in position for use, the other extension or extensions being formed or each formed with a slot open at one end, substantially as described for the purpose specified. 9th. A pump accessory comprising a bar or support having a removable laterally extending foot-piece at its lower end, and at its upper end two lateral extensions arranged a short distance apart and each formed with a slot open at one end, substantially as described for the purposes specified. 10th. A pump accessory comprising a supporting body adapted to be held upon the ground, and having its upper end slotted at one side and provided with a spring clip device consisting of a strip of spring steel secured at its central portion to said supporting body, and bent to a more or less circular shape with curved ends substantially as herein described. 11th. A pump accessory comprising a rest or support adapted to be held upon the ground, and having at its upper end a

spring clip device consisting of a pair of circularly bent spring arms adapted to clamp around and hold the stationary part of an air pump barrel, said upper end of the rest or support having a vertical slot open at one side, and said bent spring arms being arranged a short distance above the slotted upper end of said rest or support, so as to form therewith slots adapted to be engaged by a lateral movement with horizontal projections on the normally stationary part of an air pump, substantially as described. 12th. A pump rest or support comprising a pair of uprights 1 connected at their lower ends to a fixed or movable foot-piece 2, and at their upper ends to a centrally perforated top part 4 having a lateral slot 5, and a circularly bent spring clip 9 fixed at its central portion to an upward extension of the part 4 and shaped to leave slots or spaces 4^b between its free ends and said part 4, substantially as herein described for the purposes specified. 13th. The combination with an air pump having an axial air outlet with flexible air delivery pipe, of a detachable rest or support adapted to support the pump with its axial air outlet above the ground, substantially as described.

No. 58,353. Velocipede Handle-Bar.
(*Poignée de barres de bicycles.*)

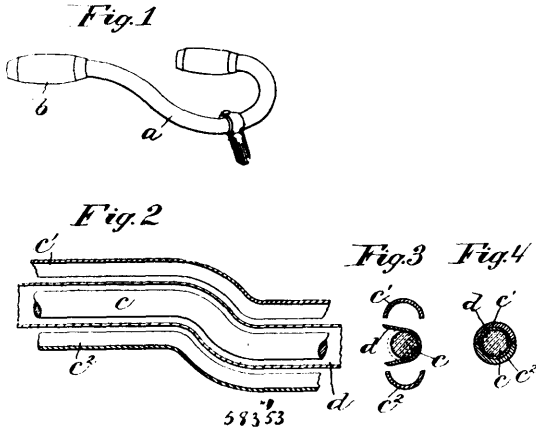

Charles F. Church, Newark, New Jersey, U.S.A., 11th December, 1897; 6 years. (Filed 3rd November, 1897.)

Claim.—1st. As an improved article of manufacture, a handle-bar of wood having a thin covering layer of celluloid or like material formed upon and moulded to the bar, and intimately united to its surface by the application of heat and pressure, all substantially as described. 2nd. As an improved article of manufacture, a handle-bar of wood having a thin covering layer of celluloid or like material formed upon and moulded to the bar, and intimately united to its surface by the application of cement, heat and pressure, all substantially as described. 3rd. As an improved article of manufacture, a handle-bar of bent wood having a thin covering layer of celluloid or like material formed upon, cemented and moulded to the bar, and intimately united to its surface by the application of heat and pressure, all substantially as described.

No. 58,354. Vehicle Wheel. (*Roue de voitures.*)

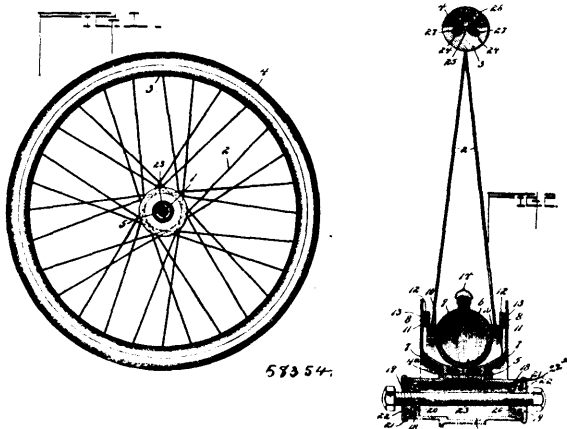

Harry R. Collins, South Bethlehem, Pennsylvania, U.S.A., 11th December, 1897; 6 years. (Filed 27th November, 1897.)

Claim.—1st. In a vehicle wheel, the combination with the hub of an annular saddle secured thereon having vertically disposed side flanges, a pneumatic tube or cushion seated on said saddle between said flanges, and a spoke-ring encircling said tube and confined

between said flanges by studs or projections on one of said parts engaging radial grooves or guide-ways in the other part, so as to cause the two parts to rotate together, whereby a pivotal connection is found between the saddle and spoke-ring which compels them to rotate together, while permitting relative rectilinear movement thereof and a swinging or oscillatory movement of the spoke-ring about said pivot as a centre. 2nd. A pneumatic hub for vehicle wheels, comprising a hub proper having an annular saddle removably secured thereon composed of two members, each provided with a vertically disposed flange having a radial groove or slot in its inner surface opposite or in alignment with the corresponding groove of the other member, a pneumatic tube or cushion encircling said saddle between said flanges, and a spoke-ring encircling said tube and movably relatively to said saddle so as to effect the compression of the tube, said spoke-ring being provided with a stud or lateral projection at each side thereof engaging one of said radial grooves, so as to pivotally connect the saddle and spoke-ring and compel them to rotate together, while permitting relative rectilinear movement thereof, and a swinging or oscillatory movement of the spoke-ring about said pivot as a centre, substantially as described. 3rd. A pneumatic hub for vehicle wheels comprising a hub proper having a sleeve which is threaded exteriorly between its ends, and provided with a shoulder at one terminus of said thread and with a removable nut or collar at the other, a saddle composed of two parts each having an interiorly screw-threaded ring or seat-portion adapted to be screwed on said thread and together forming the saddle, each of said rings being also provided with an annular flange, which latter have opposed radial grooves or guide-ways on their inner faces, a pneumatic tube or cushion seated on said saddle between the flanges of said seat portions leaving an intervening space between the same and said flanges to permit the tube to freely expand or flatten against and in the saddle, and a spoke-ring encircling said tube and movably relatively to said saddle, having a stud or lateral projection at each side thereof, engaging one of said radial grooves or guide-ways, substantially as described. 4th. A pneumatic hub for vehicle wheels comprising a hub proper having a sleeve which is threaded exteriorly between its ends and provided with a shoulder at one terminus of said thread and with a removable nut or collar at the other, a saddle composed of two parts each having an interiorly screw-threaded ring or seat-portion adapted to be screwed on said thread and together forming the saddle, each of said rings being also provided with an annular flange, which latter have opposed radial grooves or guide-ways on their inner faces, a pneumatic tube or cushion seated on said saddle between the flanges of said seat-ports, leaving an intervening space between the same and said flanges to permit the tube to freely expand or flatten against and in the saddle, and a spoke-ring encircling said tube and movably relatively to said saddle, having a stud or lateral projection at each side thereof, engaging one of said radial grooves or guide-ways, and antifriction bearings or rollers between said studs and guide-ways, substantially as described. 5th. In a vehicle wheel, the combination with a hub, of an annular saddle having a vertically disposed flange or plate at each side thereof, provided with a radial groove or slot in its inner face arranged opposite or in alignment with the corresponding groove in the inner face of the other flange, a pneumatic tube or cushion seated on said saddle and a spoke-ring movable relatively to said saddle so as to effect the compression of said tube and having a stud or lateral projection at each side thereof engaging one of said radial grooves, whereby a pivotal connection is formed between the saddle and spoke-ring to compel them to rotate together while permitting relative rectilinear movement thereof and a swinging or oscillatory movement of the spoke-ring about said pivot as a centre, substantially as described. 6th. In a vehicle wheel, the combination with a hub exteriorly screw-threaded at its middle portion with a shoulder or collar at one terminus of the screw-thread, a saddle provided with an interior screw-thread engaging the screw-threaded part of the hub and abutting against the said shoulder, a removable interiorly screw-threaded collar screwing on the hub and against the saddle for locking it on the hub, a pneumatic tube on said saddle, and a spoke-ring enclosing said tube, substantially as described. 7th. In a vehicle wheel, the combination with a hub exteriorly screw-threaded at its middle portion with a shoulder or collar at one terminus of the screw-thread, a saddle formed of a pair of similar parts each provided with an interior screw-thread engaging the screw-threaded part of the hub and one abutting against the collar and the other against its mate, a removable interiorly screw-threaded collar screwing on the hub and against the saddle for locking the latter on one hub, a pneumatic tube on said saddle, and a spoke-ring enclosing said tube, substantially as described.

No. 58,355. Bicycle Brake. (*Frein de bicycles.*)

Abram W. Duck, Oakland, California, U.S.A., 11th December, 1897; 6 years. (Filed 29th November, 1897.)

Claim.—1st. In a bicycle brake, a plurality of rollers journaled upon shafts extending downwardly and forwardly at an obtuse angle with each other, and means for forcing the rollers into contact with the tire. 2nd. In a bicycle brake, a plunger rod having shafts at its lower ends extending in opposite directions downwardly and forwardly at an obtuse angle, rollers on said shafts, frictional washers on the outer portions of the shafts to receive the outward pressure of the rollers, and means for forcing the rollers in contact

with the tire. 3rd. In a bicycle brake and in combination with the brake rod, an actuating bell-crank lever connected with the rod and

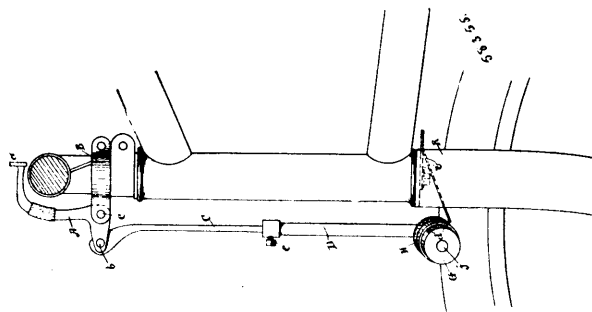

having its free end curved over and behind the handle bars so that the lever lies in the direction of the line of travel of the machine. 4th. In a bicycle brake, rollers journalled upon shafts extending downwardly and forwardly at an obtuse angle from their junction, a plunger rod fixed to the junction of said shafts extending upwardly having its upper end connected with one arm of a bell-crank lever, the other arm of said lever extending upwardly and bent backwardly above the handle bar of the machine and having transverse extensions, a clamp fixed to the stem and below the handle bar, a fulcrum pin upon which the angle of the bell-crank lever is turnable whereby the brake is applied by moving the lever in the line of travel of the machine. 5th. In a bicycle brake, a brake lever, a plunger rod having the upper end connected with the brake lever, and the lower end connected with shafts which diverge downwardly and forwardly from the point of junction, rollers mounted and turnable upon said shafts, said rollers having essentially cylindrical faces to contact with the tire upon each side of a central line, screw-threaded frictional washers adjustable upon the ends of the roller shafts and against which the outer ends of the rollers abut, and a spring extending forwardly from the lower part of the steering-head engaging the washers and supporting the plunger shaft, and the rollers normally out of contact with the tire. 6th. In a bicycle brake, a vertically movable plunger rod having its upper end connected with a brake lever whereby the plunger rod is depressed, shafts having the junction connected with the lower end of the plunger rod and extending at an angle downwardly and forwardly from said junction, rollers journalled upon said shafts having the outer portion of their faces made cylindrical and the inner portion curved, screw-threaded washers fitting corresponding threads upon the outer ends of the roller shafts whereby the frictional contact between said washers and the outer ends of the rollers is regulated, a spring secured between the forks at the lower end of the steering-post of the bicycle, serving to support the plunger rod and the rollers normally out of contact with the bicycle tire and having the forward ends adapted to enter perforations in the washers exterior to the rollers whereby the device is supported and the washers prevented from turning. 7th. In a bicycle brake, a vertically movable plunger rod having the upper end connected with a brake lever, the lower end carrying downwardly and forwardly diverging shafts, rollers journalled upon said shafts and having cylindrical contact surfaces to press upon the tire at each side of the central line, circular screw-threaded washers fitting and adjustable upon the ends of the shafts to form frictional contact with the outer ends of the rollers, a spring having its forward ends adapted to enter perforations in the washers, whereby the rollers are normally supported out of contact with the tire and the washers are prevented from turning, said spring extending rearwardly between the forks of the bicycle and bent transversely across behind said forks having a central portion, and means for securing it centrally within the fork crown, whereby said spring forms a yielding support to normally hold the rollers out of contact with the tire, a stop to prevent the rollers and plunger rod from being moved forwardly when the brake is applied, and means for locking the frictional washers to prevent their rotation.

No. 58,356. Bicycle Tire Pump.

(*Pompe pour bandages de bicycless.*)

Augustus Gross, 156 Vickery's Chambers, 82 Pitt Street, Sydney, New South Wales, Australia, 11th December, 1897; 6 years. (Filed 29th November, 1897.)

Claim.—1st. In apparatus for automatically inflating pneumatic tires, the employment of a disc with a hub cavity, and having in its outer periphery a central groove to receive a corresponding tongue on the internal periphery of a ring, the latter being connected with an air pump secured to the tire valve, the said disc being secured in a stationary position by being fastened to the axle or other stationary part of the cycle or vehicle, and the pump being operated by the rotation of the cycle or vehicle wheel, substantially as herein described, explained and illustrated in the drawings. 2nd. In apparatus for automatically inflating pneumatic tires, an air pump in combination with an exhaust valve, having a valve plug as X, substantially as herein described, explained and illustrated in the drawings. 3rd. In apparatus for automatically inflating pneumatic

tires, the combination with a pump barrel, of the piston head as f, provided with an air passage as h, the lower end being covered with

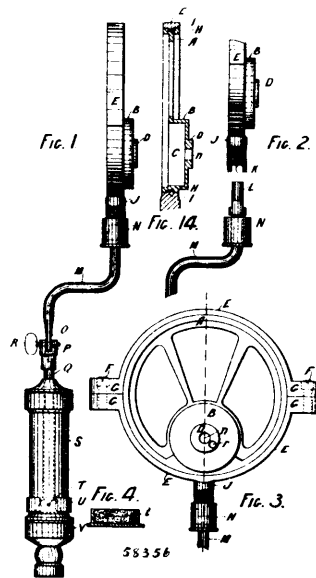

a strip of oiled silk, or its equivalent to form a valve, substantially as herein described, explained and illustrated in the drawings. 4th. The combination and arrangement of the various parts herein described, explained and illustrated, altogether forming the improvements in or relating to automatic action pumps for inflating pneumatic tires, of cycles and other vehicles, substantially as and for the purposes set forth.

No. 58,357. Bicycle Support. (*Support de bicycless.*)

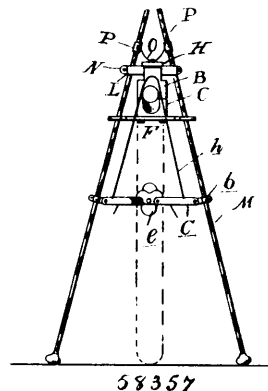

William Hayball and Lucien E. Ellis, Detroit, Michigan, U.S.A., 11th December, 1897; 6 years. (Filed 15th November, 1897.)

Claim.—1st. In a bicycle-support, in combination, a clamp, a block or plate pivoted thereon, legs pivoted in the ends of the plate, a spring acting to draw the legs together, and handles formed by extensions of the legs above their pivotal point by means of which the legs may be rocked and the feet spread. 2nd. In a bicycle-support, in combination, a clamp, the plate pivoted to the clamp, the legs pivoted in the plate and extending above the same to form handles, means for forcing the legs together, and the rule-jointed levers connecting the legs to hold them in their spread position. 3rd. In a bicycle-support, in combination, a clamp, the plate pivoted to the clamp, the legs pivoted to the plate, the plate F having bayonet-slots G, and the rule-jointed levers connecting the legs. 4th. In a bicycle-support, in combination, the clamp, the pivoted rocking legs, the rule-jointed levers, and the loop h, connecting the levers for the purpose described. 5th. In a bicycle-support, the combination of the rocking legs, a brake-block between said legs, links pivoted to said legs and to the block, adapted when in alignment to hold the legs apart or in their supporting position and adapted to apply the brake-block, and shoulders on the brake-block adapted to engage the links and lock them in their aligned position, substantially as described. 6th. In a bicycle-support and in combination, a clamp, a plate hinged to said clamp, legs pivotally connected to said plate the legs together, and means on one side of the pivot for holding the legs in supporting position.

No. 58,358. Bicycle. (Bicycle.)

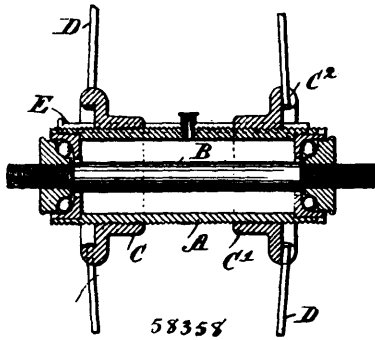

David Morgan, No. 153 George Street, Launceston, Tasmania, 11th December, 1897; 6 years. (Filed 20th November, 1897.)

Claim.—1st. In a wheel principally applicable for bicycles and other road vehicles, a right and left hand screw-threaded barrel or hub body, such as A, in combination with correspondingly threaded flanges, such as C, C', with which the inner ends of the spokes of the wheel engage, the outer ends of said spokes being in engagement with the rim, substantially as and for the purposes herein described and explained and as illustrated in the accompanying drawings. 2nd. In a wheel principally applicable for bicycles and other road vehicles, a screw-threaded barrel or hub body, such as A, in combination with a correspondingly threaded flange, such as C, adapted to be drawn nearer to or moved further from the other flange C', in order to tighten the spokes on the wheel, substantially as and for the purposes herein described and explained and as illustrated in the accompanying drawings. 3rd. In a wheel principally applicable for bicycles and other road vehicles a screw-threaded barrel or hub body, such as A, having a fixed flange, such as C', at one end, in combination with an adjustable flange, such as C, fitted loosely on the outside of said barrel or hub body, together with an adjusting nut, such as C², bearing against said flange and working upon the screw-threaded surface of said barrel or hub body, substantially as and for the purposes herein described and explained and as illustrated in the accompanying drawings.

No. 58,359. Bicycle. (Bicycle.)

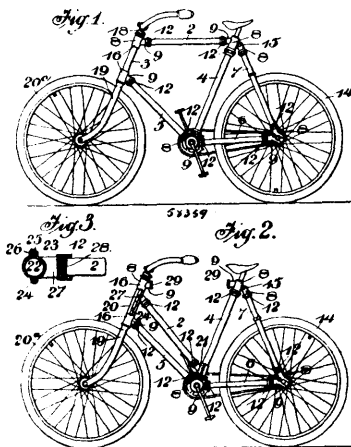

Lyman Ferguson, Ithaca, New York, U.S.A., 11th December, 1897; 6 years. (Filed 16th November, 1897.)

Claim.—1st. In a bicycle, the combination with the frame bars and braces forming the frame, of metal coupling pieces for the contiguous ends of the different bars and braces, said metal coupling pieces being provided with tubular necks exteriorly threaded and formed with a plurality of inwardly extending slits, and interiorly threaded nuts working over the ends of the bars and braces fitting in said necks and engaging with the exterior threads of the latter, substantially as set forth. 2nd. In a convertible bicycle, the combination of the frame having a removable upper frame bar, couplings for detachably connecting the ends of said frame bar respectively with the upper ends of the head tube and seat post brace of the frame, and a pair of removable couplings detachably fitted respectively to the head tube and the lower end of the seat post brace of the frame and adapted to engage with the ends of the removable frame bar, substantially as set forth. 3rd. In a convertible bicycle,

the combination of the frame having a removable upper frame bar, and couplings respectively at the upper ends of the head tube and seat post brace detachably engaging with the ends of said bar, a pair of separate couplings fitted respectively to the head tube and the lower end of the seat post brace of the frame and adapted to engage with the ends of said removable frame bar when in its lowered position, and caps removably fitted to the neck portions of the upper set of couplings for the removable frame bar, substantially as set forth. 4th. In a convertible bicycle, the combination of the frame having a removable upper frame bar, and couplings respectively at the upper ends of the head tube and seat post brace detachably engaging with the ends of said bar, a separate pair of front and rear removable coupling pieces detachably clamped respectively to the head tube and the lower end of the seat post brace, each of said removable couplings comprising a sectional hinged clamp sleeve and an off-standing coupling neck detachably engaging with the ends of the removable frame bar when in its lowered position, substantially as set forth.

No. 58,360. Velocipede Brush. (Brosse de vélocipèdes.)

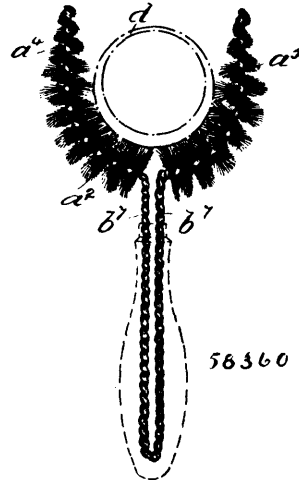

Earl E. Flemming, Schönheide, Saxony, Germany, 11th December, 1897; 6 years. (Filed 29th November, 1897.)

Claim.—1st. In a cycle brush having two bristle bodies, the bristles of which are held by means of a spiral double wire which also connects the said bodies, the arrangement whereby the intermediate part of the twisted wires, which is free from bristles, is bent away from or out of the direction of union, and is led back into the said direction in such a manner as to form a widened part which is adapted to be used as a handle, substantially as described. 2nd. A cycle brush of the kind referred to in claim 1, in which the widened part is prolonged to form a shank or handle, substantially as described. 3rd. A cycle brush of the kind referred to in claims 1 and 2, in which the shank or handle is bent away, and extends at a right or other angle to the direction of the bristle bodies, such handle being situated in the common plane of the bristle bodies, substantially as described. 4th. A cycle brush of the kind referred to in claims 1 and 2, in which the shank is bent away, and extends at a right or other angle to the direction of the bristle bodies, and also at an angle to the common plane of the latter, substantially as described. 5th. A cycle brush of the kind referred to in claim 1, in which the bristle bodies are curved in the arc of a circle, substantially as described. 6th. A cycle brush of the kind specified in claims 1 and 5, in which the shank of the brush extends in the direction of a radius of the tire, substantially as described. 7th. A cycle brush of the kind referred to in claims 1 and 5, in which the shank of the brush extends at or about right angles to a radius of the tire, substantially as described. 8th. A cycle brush of the kind referred to in claims 1 and 5, in which the curved bristle bodies have prolongations which extend in straight parallel lines, substantially as described. 9th. A cycle brush of the kind specified in claims 1 and 8, in which a single bristle body is arranged in a removable manner between the two curved bristle bodies, substantially as described.

No. 58,361. Mechanical Joints for Vehicle Frames.

(Joint pour montures de bicyclettes.)

The Pope Manufacturing Company, assignee of James Samuel Copeland, all of Hartford, Connecticut, U.S.A., 13th December, 1897; 6 years. (Filed 3rd November, 1897.)

Claim.—1st. As an improved article of manufacture, a vehicle frame including a bracket member and a separable tubular member, one of said members having a socket adapted to receive the opposite member, registering bolt sockets in said members, and a locking

bolt, or pin, located in said sockets, all substantially as described. 2nd. As an improved article of manufacture, a vehicle frame com-

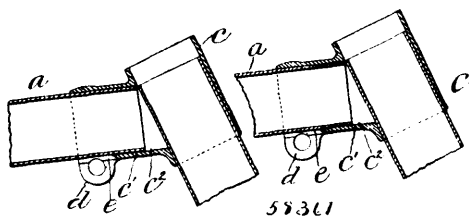
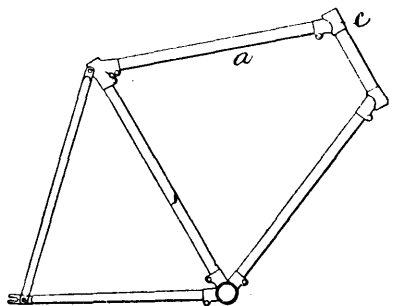

prising bracket members and separable tubular members, the bracket member having a socket for the reception of the end of the tubular member, means for compressing the walls of said socket in the bracket upon the tube end, all substantially as described. 3rd. As an improved article of manufacture, a vehicle frame comprising bracket members and separable tubular members, the bracket member having a tang with a threaded socket and the tubular member having a threaded end fitting said socket, a lengthwise slot through the wall of the tang and a transverse bolt for contracting the diameter of the socket in the tang, all substantially as described. 4th. As an improved article of manufacture, a vehicle frame comprising bracket members and separable tubular members, the bracket member having a tang with a socket, a lengthwise slot and perforated lugs located on opposite sides of the slot, and the tubular member having a transverse bolt socket formed in the wall of the tube near its end, and a transverse bolt extending through the lugs and projecting into the socket in the tube, all substantially as described. 5th. In combination in a vehicle frame, bracket members and separable tubular members, the bracket members having a tang with a threaded socket, projecting lugs located on opposite sides of a lengthwise slot through the wall of the tang, a transverse bolt extending across the tang and through holes in the lugs, and the tubular member with a threaded end fitting the threaded socket in the tang, and a transverse bolt socket into which the transverse bolt projects when the parts are engaged, and means for compressing the walls of the socket in the tang upon the end of the tubular member, all substantially as described.

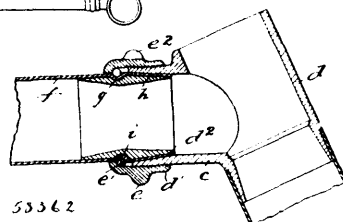
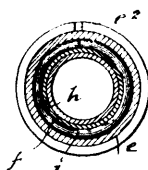
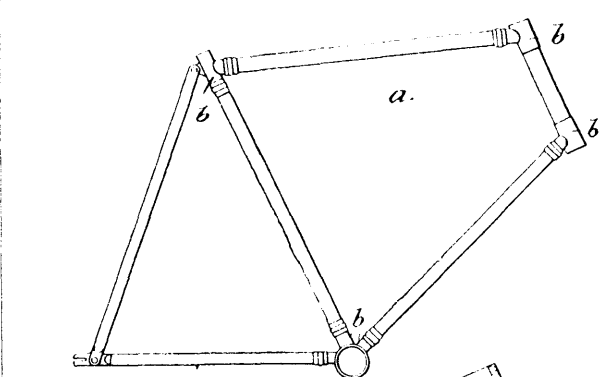

prising bracket members and separable tubular members, the bracket member having a socket for the reception of the end of the tubular member, means for compressing the walls of said socket in the bracket upon the tube end, all substantially as described. 3rd. As an improved article of manufacture, a vehicle frame comprising bracket members and separable tubular members, the bracket member having a tang with a threaded socket and the tubular member having a threaded end fitting said socket, a lengthwise slot through the wall of the tang and a transverse bolt for contracting the diameter of the socket in the tang, all substantially as described. 4th. As an improved article of manufacture, a vehicle frame comprising bracket members and separable tubular members, the bracket member having a tang with a socket, a lengthwise slot and perforated lugs located on opposite sides of the slot, and the tubular member having a transverse bolt socket formed in the wall of the tube near its end, and a transverse bolt extending through the lugs and projecting into the socket in the tube, all substantially as described. 5th. In combination in a vehicle frame, bracket members and separable tubular members, the bracket members having a tang with a threaded socket, projecting lugs located on opposite sides of a lengthwise slot through the wall of the tang, a transverse bolt extending across the tang and through holes in the lugs, and the tubular member with a threaded end fitting the threaded socket in the tang, and a transverse bolt socket into which the transverse bolt projects when the parts are engaged, and means for compressing the walls of the socket in the tang upon the end of the tubular member, all substantially as described.

elled inner surface and the tubular member having its end bevelled to fit the bevelled surface on the tang, a peripheral groove located in the tubular member, a ring located in said groove and projecting beyond the surface of the tube, a collar having a thread fitting the threaded surface on the tang and a shoulder engaging the shoulder formed by the ring, all substantially as described. 6th. In combination in a vehicle frame comprising bracket members and a removable tubular member, the bracket member having a threaded tang, and the tubular member having near its end a removable shouldered part fixed against longitudinal movement on the tube, interengaging locking parts located on the bracket member and tang respectively, and a collar having a threaded surface fitting the threaded surface on the tang and a flange engaging the shoulder on the tube, all substantially as described.

No. 58,362. Mechanical Joints for Vehicle Frames.
(*Joint pour montures de bicycles.*)

The Pope Manufacturing Company, assignee of James Samuel Copeland, all of Hartford, Connecticut, U.S.A., 13th December, 1897; 6 years. (Filed 3rd November, 1897.)

Claim.—1st. As an improved article of manufacture, a vehicle frame composed of separable members, including a bracket member and a tubular member having interengaging projections on their meeting faces, and means for drawing said parts together to firmly hold the interengaging surfaces in contact, all substantially as described. 2nd. In combination in a vehicle frame, a bracket member and a tubular member separable therefrom, a thread on one of said parts, a split ring fitting a groove on the opposite part and forming a shoulder, a collar having a thread fitting the threaded member and a flange arranged to engage the shoulder on the opposite member, all substantially as described. 3rd. The combination in a vehicle frame, a bracket member and a tubular member separable therefrom, the bracket member having a threaded tang and the tubular member having a groove with a split ring fitting therein and forming a shoulder held against longitudinal movement on said member, a collar having a threaded surface fitting the threaded surface on the tang and also a flange engaging said shoulder, all substantially as described. 4th. In combination in a vehicle frame comprising bracket members and separable tubular members, the bracket member having a socket with a bevelled inner surface, a bevelled surface on the end of the tubular member, a thread on one of said members, a shoulder on the opposite member, and a collar having a thread engaging the threaded surface of the one member and a flange engaging the rearward facing shoulder on the opposite member, all substantially as described. 5th. In combination in a

No. 58,363. Joint for Vehicle Frames.
(*Joint pour montures de bicycles.*)

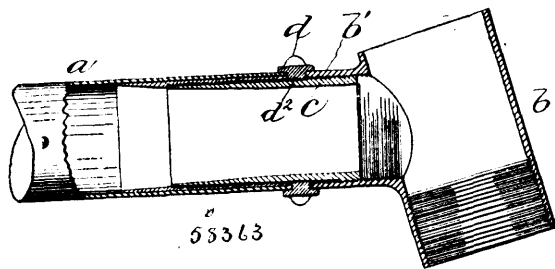

The Pope Manufacturing Company, assignee of James Samuel Copeland, all of Hartford, Connecticut, U.S.A., 13th December, 1897; 6 years. (Filed 3rd November, 1897.)

Claim.—1st. In combination in a vehicle frame, a tubular member and a bracket member each having a threaded socket, a threaded coupling fitting said sockets and having a lengthwise peripheral slot, and a collar loosely mounted on the coupling and closing the joint between the tube and the bracket member and with a lug engaging said slot, all substantially as described. 2nd. In combination in a vehicle frame, a tubular member and a bracket member each having a threaded socket, a threaded coupling fitting said sockets and having a lengthwise peripheral slot, the threads on opposite ends of the coupling being of different pitch, and a collar loosely mounted on the coupling and closing the joint between the tube and the bracket member and with a lug engaging said slot, all substantially as described.

No. 58,364. Mechanical Joints for Vehicle Frames.
(*Joint pour montures de bicycles.*)

The Pope Manufacturing Company, assignee of James Samuel Copeland, all of Hartford, Connecticut, U.S.A., 13th December, 1897; 6 years. (Filed 3rd November, 1897.)

Claim.—1st. A vehicle frame made up of separable members in which each bracket member and a frame part is provided with

threaded surfaces at the abutting ends, and a threaded sleeve overlying, engaging and fitting upon the ends of connecting parts and

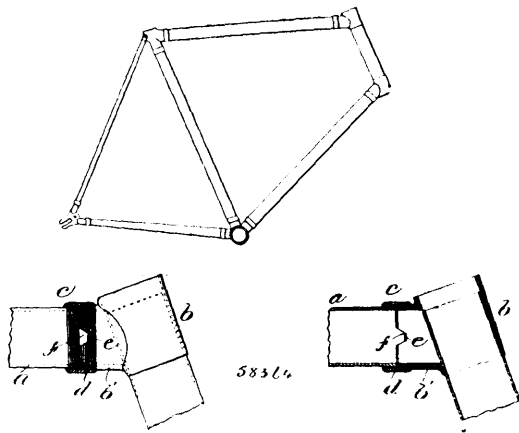

securing them together, the threads on the opposing parts being of different pitch or differing in the direction of their spiral path about the member, all substantially as described. 2nd. As an improved article of manufacture, a bicycle frame comprising a bracket member with a threaded tang and a tubular member with a reversely threaded end, interengaging parts on the abutting faces of the tang and the tube, and a sleeve fitting the respective threaded tang and threaded tube end and securing the parts together against lateral and longitudinal displacement, all substantially as described. 3rd. As an improved article of manufacture, a bicycle frame with bracket members having threaded tangs, tubular members with reversely threaded ends as compared with the thread on the opposing bracket member, interengaging parts on the abutting ends of the tang and tubes respectively, and threaded sleeves fitting each threaded joint and securing the parts together, all substantially as described.

No. 58,365. Mechanical Joints for Vehicle Frames.
(*Joint pour montures de bicycles.*)

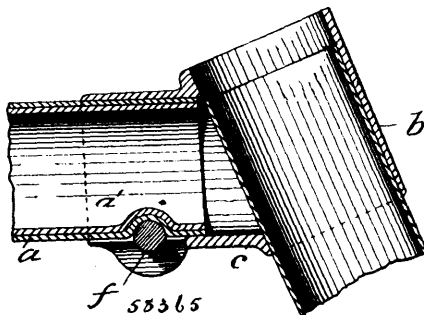

The Pope Manufacturing Company, assignee of James Samuel Copeland, all of Hartford, Connecticut, U.S.A., 13th December, 1897; 6 years. (Filed 3rd November, 1897.)

Claim.—1st. In combination in a vehicle frame having separable members, a main frame member having near its end a transverse socket, a bracket member having a tang with a transverse socket, and a removable pin in the transverse sockets of the main frame member and the bracket member whereby the said members are separably secured together, all substantially as described. 2nd. In combination in a vehicle frame having separable members, a bracket member having a hollow tang with a transverse pin socket, a main frame member with its end adapted to fit closely within the hollow tang and having near its end a transverse socket or indentation, and a removable transverse pin fitting within the sockets of the tang and frame parts and separably binding together the frame member and the bracket member, all substantially as described. 3rd. In combination in a vehicle frame comprising separable members, a bracket member having a tang with a threaded lengthwise socket and a transverse pin socket, a main frame member having a threaded end fitting said socket in the tang, and having near its end a transverse socket or indentation, and a removable transverse pin fitting within the sockets of the tang and frame member and separably securing together the said frame member and bracket member, all substantially as described.

No. 58,366. Joint for Vehicle Frames.
(*Joint pour montures de bicycles.*)

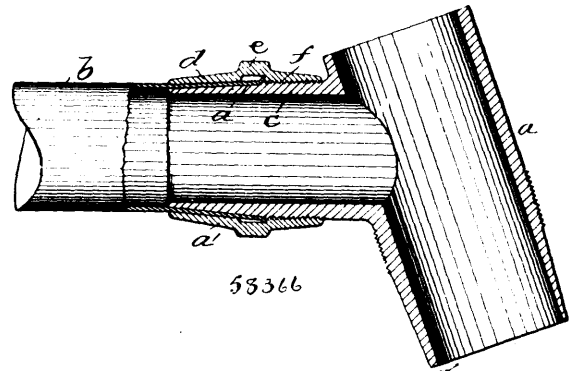

The Pope Manufacturing Company, assignee of James Samuel Copeland, all of Hartford, Connecticut, U.S.A., 13th December, 1897; 6 years. (Filed 3rd November, 1897.)

Claim.—1st. In combination in a vehicle frame having bracket members and separable tubular members, a bracket having a threaded tang with tapered surface adapted to receive a tube end, a tubular member having its end tapered to fit upon the tang, and a clamping-nut or collar surrounding the tube end and having a thread fitting upon the threaded part of the tang and clamping the tube end between the tapered surface on the tang and collar respectively, all substantially as described. 2nd. In combination in a vehicle frame, a bracket member with a threaded tang and a tapered surface, a tubular member having its end tapered to fit upon the tang, a loose ring having a tapered inner surface fitting upon the flaring end of the tube, and a clamping-nut with a shoulder formed to engage the edge of the loose ring, and a threaded portion fitting upon the threaded part of the tang, all substantially as described. 3rd. In combination in a vehicle frame, a bracket member having a threaded tang with a central opening, a tubular member having a reinforce less in diameter than the tube and with its end projecting through the socket in the tang, and a collar with a thread arranged to engage the threaded shoulder portion of the tang, and having a shoulder fitting against a shoulder on the tube, all substantially as described.

No. 58,367. Pneumatic Tire. (*Bandage pneumatique.*)

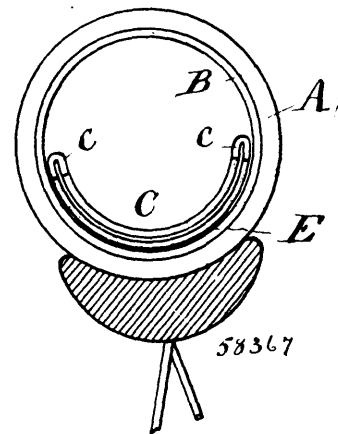

Morgan & Wright, assignees of Ernest W. Young, all of Chicago, Illinois, U.S.A., 13th December, 1897; 6 years. (Filed 13th January, 1896.)

Claim.—1st. A pneumatic tire containing a normally flattened patching tube arranged over the base portion of the tire, and adapted to interiorly communicate with the interior of the tire, whereby said tube can be used as a patching device, substantially as set forth. 2nd. A pneumatic tire containing a normally flattened patching tube provided with openings along its edge portions, substantially as set forth. 3rd. A pneumatic tire provided with an internally arranged normally flattened patching tube which is secured at one of its flattened sides to the base portion of the tire and adapted to interiorly communicate with the interior of the latter, substantially as set forth. 4th. The combination in a pneumatic tire, of a sheath, the inner air-tube, and a normally flattened patching tube arranged within the air-tube and adapted to interiorly communicate with the interior of the air-tube, substantially as set forth.

No. 58,368. Crank Axle and Crank for Velocipedes.
(Essieu coudé et bielle de vélocipèdes.)

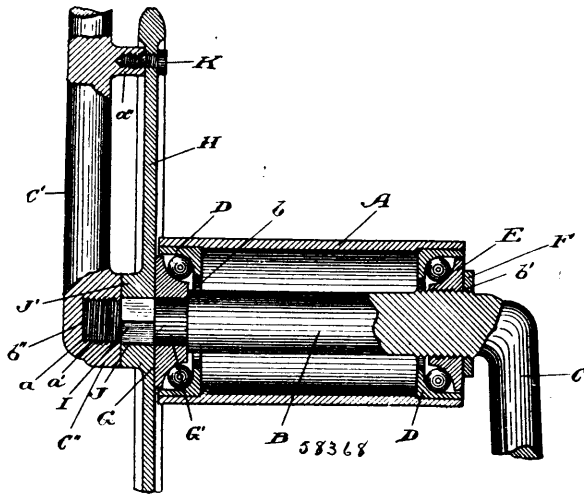

Charles L. McQuillan, Toronto, Ontario, Canada. 13th December, 1897; 6 years. (Filed 2nd November, 1897.)

Claim.—1st. In a velocipede, the combination of a crank axle, a crank rigidly fixed to the crank axle, the end of the crank axle screw-threaded, and a detachable crank, having a hub provided with a screw-threaded bore fitted on the end of the crank axle, substantially as specified. 2nd. In a velocipede, the combination of a crank axle, a crank rigidly fixed to the crank axle, the end of the crank axle screw-threaded, a detachable crank having a hub provided with a screw-threaded bore fitted on the end of the crank axle, a seat for the bore of the hub of the sprocket-wheel, contiguous to the screw-threaded end of the crank axle, a sprocket wheel fitted on the seat, and a binding screw passing through the sprocket-wheel, and entering the detachable crank, substantially as specified. 3rd. In a velocipede, the combination of a crank axle, a crank rigidly fixed to the crank axle, the end of the crank axle screw-threaded, a detachable crank, having a hub provided with a screw-threaded bore fitted on the end of the crank axle, a seat for the bore of the hub of the sprocket-wheel, contiguous to the screw-threaded end of the crank axle, a sprocket-wheel fitted on the seat, a binding screw passing through the sprocket-wheel, and entering the detachable crank, and a shoulder on the crank axle, against which abutts one of the bearing cones, to permit the sprocket-wheel and bearing cone being jammed between the shoulder and the hub of the detachable crank, substantially as specified.

No. 58,369. Hub Brake for Bicycles.
(Frein de moyeu pour bicyclet.)

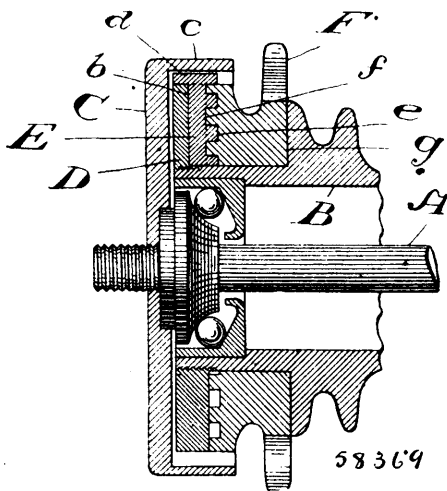

Alfred William Waters and The Gendron Manufacturing Co., all of Toronto, Ontario, Canada, 13th December, 1897; 6 years. (Filed 5th November, 1897.)

Claim.—1st. In a bicycle, a brake composed of a stationary and a rotatable member normally concentric and inoperative with regard to one another, the rotatable member slidably supporting one or more friction dogs, in combination with a sprocket wheel rotatable

with regard to and adapted to drive the said rotatable member or to press the said friction dogs into contact with the stationary member when rotated in a backward direction, substantially as and for the purpose specified. 2nd. In a bicycle, an axle and a stationary drum carried by the said axle, in combination with a hub, a friction dog movably supported upon the said hub within the drum and provided upon its face with a segment of a spiral thread, and as sprocket-wheel loose upon the hub and suitably threaded to engage the said dog and expand it within the drum when the rider back pedals, substantially as and for the purpose specified. 3rd. In a bicycle, an axle and a stationary drum carried by the said axle, in combination with a hub, a disc rigidly connected to the hub within the drum, one or more friction dogs slidable in radial grooves formed in the said disc and each provided upon its face with a segment of a spiral thread and a sprocket-wheel loose upon the hub and suitably threaded to engage the said dogs and to force them into contact with the drum or the disc according to the direction in which it is revolved, substantially as and for the purpose specified. 4th. In a bicycle, an axle and a stationary drum carried by the said axle and provided with a pin to engage a portion of the frame, in combination with a hub, a disc rigidly connected to the hub within the drum, one or more friction dogs slidable in radiable grooves formed in the said disc and each provided upon its face with a segment of a spiral thread, and a sprocket-wheel loose upon the hub and suitably threaded to engage the said dogs and to force them into contact with the drum or the disc according to the direction in which it is revolved, substantially as and for the purpose specified. 5th. In a bicycle, the combination of the axle A, the hub B, the friction drum C, stationary upon the said axle, the disc D, fixed to the said hub and grooved at *b*, one or more friction dogs E, set in the grooves *b* and provided with heads *d*, and segmental spiral threads *c*, and the sprocket-wheel F, loose on the hub B, and provided with the spiral thread *f* to engage the threads *c*, substantially as and for the purpose specified. 6th. In a bicycle, the combination of the axle A, the hub B, having a flange *a* formed thereon, the friction drum C, stationary upon the said axle, the disc D, fixed to the said hub and grooved at *b*, one or more friction dogs E, set in the grooves *b* and provided with heads *d*, and segmental spiral threads *c*, and the sprocket-wheel F, loose on the hub B, and provided with the spiral thread *f* to engage the threads *c*, substantially as and for the purpose specified. 7th. In a bicycle, the combination of the axle A, the hub B, the friction drum C, stationary upon the said axle, and provided with a pin *a* to engage a portion of the frame, the disc D, fixed to the said hub and grooved at *b*, one or more friction dogs E, set in the grooves *b*, and provided with heads *d* and segmental spiral threads *c*, and the sprocket-wheel F, loose on the hub B, and provided with the spiral thread *f* to engage the threads *c*, substantially as and for the purpose specified. 8th. A bicycle hub-brake comprising the following instrumentalities: a friction drum secured to the axle, a rotatable disc secured to the hub, one or more friction dogs with one or more threads formed thereon and slidably connected to the disc, a sprocket-wheel loose on the hub with the face so shaped as to engage with the thread or threads on the friction dogs, substantially as described and for the purpose specified.

No. 58,370. Handle Bar for Cycles.
(Poignée de barre de bicyclet.)

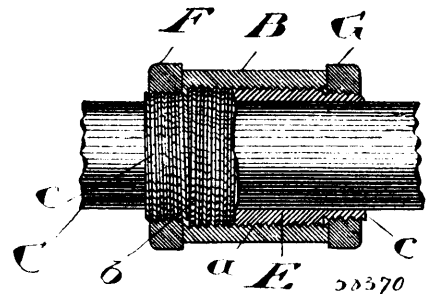

Alfred William Waters and The Gendron Manufacturing Co., 13th December, 1897; 6 years. (Filed 5th November, 1897.)

Claim.—1st. In a cycle, a handle-bar stem and a screw-threaded sleeve secured to its upper end, in combination with a handle bar having a similarly threaded sleeve on its centre and screwed within the first-named sleeve, and a nut adjustable upon the end of the sleeve in the handle bar, substantially as and for the purpose specified. 2nd. In a cycle, a handle-bar stem and a screw-threaded sleeve secured to its upper end in combination with a handle bar having a screw-threaded sleeve connected to its centre, one end of which is of less diameter than and threaded differently from the middle, and a nut screwed upon the said end, substantially as and for the purpose specified. 3rd. In a cycle, the handle bar stem A, and the sleeve B secured thereto, and having a left-hand thread *a* cut therein, in combination with the handle bar C, the sleeve E, secured thereon comprising the left-hand threaded middle portion *b* and the right-hand threaded ends *c*, and the nuts F and G screwed upon the said ends, substantially as and for the purpose specified.

No. 58,371. Trousers Clamp. (*Agrafe pour pantalons.*)

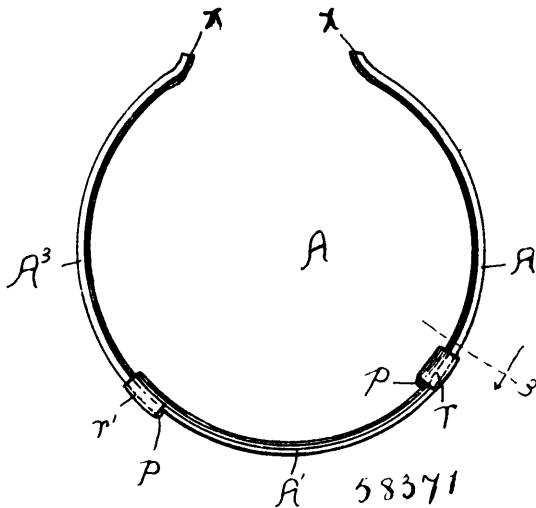

Lyman P. Converse and Charles F. Thompson, both of Chicago, Illinois, U.S.A., 13th December, 1897; 6 years. (Filed 6th November, 1897.)

Claim.—1st. A trousers clamp comprising bowed sections A¹, A² and A³, of spring metal, the section A¹ having loops r and r¹ on its opposite ends, and the sections A² and A³ being slidably confined in said loops and provided with stops p on their adjacent ends, substantially as and for the purpose set forth. 2nd. A trousers clamp comprising bowed longitudinally concavo-convex sections A¹, A² and A³, of spring metal, the section A¹ having loops r and r¹ on its opposite ends, and the sections A² and A³ being slidably confined in said loops and provided with stops p on their inner ends and with grips x on their outer ends, substantially as and for the purpose set forth.

No. 58,372. Bicycle Saddle. (*Selle de bicycles.*)

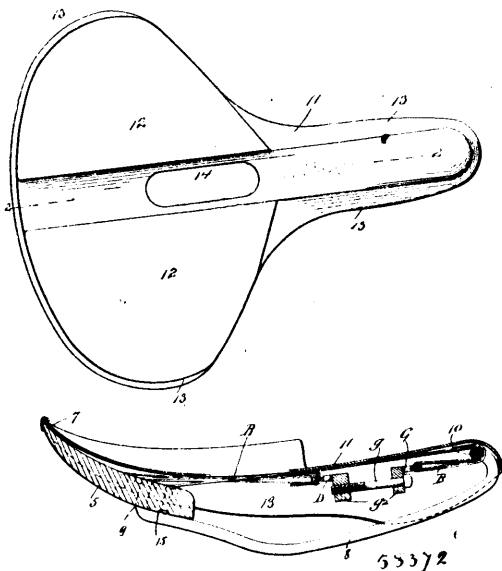

The Mesinger Manufacturing Company, assignee of Alexander John Limburg, all of New York, State of New York, U.S.A., 13th December, 1897; 6 years. (Filed 22nd November, 1897.)

Claim.—1st. A saddle for bicycles and similar vehicles, consisting of a cantle, the rear portion of which is higher than the front portion, a strong spring yoke, the ends of which are secured to the bottom thereof, and the head of which projects forwardly and is directed upwardly to form a loop, an adjusting device consisting of two links, each of which is provided with a downwardly directed head through which a screw-threaded bolt is passed, and a flexible strap which is folded centrally and passed through the cantle, and the separate ends or sides of which are passed around the forward loop of said yoke, and through the said links of the adjusting device, and through the cantle, and secured substantially as shown and described. 2nd. A saddle for bicycles and similar vehicles,

consisting of a cantle, the rear portion of which is higher than the front portion, a strong spring yoke, the ends of which are secured to the bottom thereof, and the head of which projects forwardly and is directed upwardly to form a loop, an adjusting device consisting of two links, each of which is provided with a downwardly directed head through which a screw-threaded bolt is passed, and a flexible strap which is folded centrally and passed through the cantle, and the separate ends or sides of which are passed around the forward loop of said yoke, and through the said links of the adjusting device, and through the cantle and secured, said saddle being provided with a top covering, and the body portion thereof being provided with a bottom covering, substantially as shown and described. 3rd. A saddle for bicycles and similar vehicles, consisting of a cantle, the rear portion of which is higher than the front portion, a spring yoke, the ends and the sides of which are connected with said cantle, and the head of which is carried downwardly and forwardly and curved upwardly to form a loop, an adjusting device consisting of two separate links connected by a screw-threaded bolt, said device being placed between the sides of said yoke near the front thereof, and a flexible strap which is folded centrally, and the separate sides or ends of which are passed upwardly through said cantle, said ends or sides of said strap being passed around said loop, and through the links of the adjusting device and through said cantle, substantially as shown and described. 4th. A saddle for bicycles and similar vehicles, said saddle consisting of a cantle, a strong spring yoke, the ends of the sides of which are connected with the cantle and the head of which extends forwardly and bends upwardly to form a loop, an adjustable device mounted between the sides of said yoke, and consisting of two links connected by a screw-threaded bolt, and a strap which is connected with said cantle and interwoven around said loop and through said links, substantially as shown and described. 5th. A saddle for bicycles and similar vehicles, consisting of a cantle, a strong spring yoke, the ends of the sides of which are connected with the cantle, and the head of which is extended forwardly and bent upwardly and backwardly to form a loop, an adjusting device mounted between the sides of said yoke, and consisting of two separate links connected by a screw-threaded bolt, and a flexible strap interwoven through said cantle and said links and around said loop, and the ends of which are secured substantially as shown and described.

No. 58,373. Pant Guard and Bicycle Lock. (*Garde-pantalons et serrure de bicycles.*)

(*Garde-pantalons et serrure de bicycles.*)

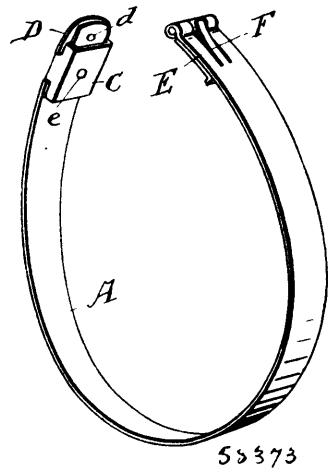

John A. Bernower, Madison W. Meredith, William Gibbs, Edward Stonehill, and William C. Bernower, assignees of Josiah J. Deal, all of Canton, Ohio, U.S.A., 13th December, 1897; 6 years. (Filed 1st December, 1897.)

Claim.—1st. A combined trousers guard and lock, consisting of a spring piece of metal, having connected at one of its free ends a spring, a guide connected to the guard, a bifurcated extension provided with flanges, and means for holding the bifurcated extensions against the inner face of the guard, substantially as and for the purpose specified. 2nd. The combination of a pair of trousers guards, one of said guards provided with a spring and a housing or guide, and a bifurcated extension provided with flanges, and a guard provided with a notch or recess upon one of its free ends, substantially as and for the purpose specified. 3rd. The combination of a combined trousers guard and lock, a spring guard having attached thereto an engaging spring, a guard surrounding the engaging spring, a bifurcated extension pivotally connected to the opposite free end of the guard having the engaging spring, and a guard provided with a notched or recessed end, substantially as and for the purpose specified. 4th. The combination of a pair of trousers guards, one of

said guards provided with an engaging spring, an extension provided with flanges or notches, and a trousers guard provided with the notch or recess, substantially as and for the purpose specified.

No. 58,374. Armour for Pneumatic Tires.
(*Armure pour bandages pneumatiques.*)

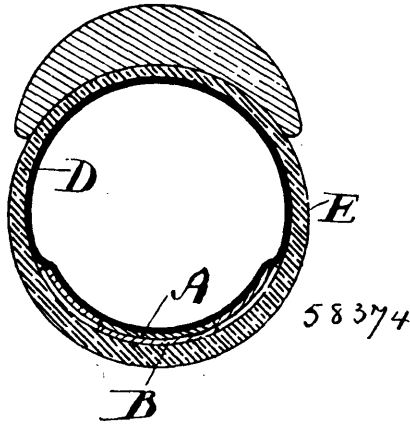

Rudolph Faas and Peter Reder, both of Chicago, Illinois, U.S.A., 13th December, 1897; 6 years. (Filed 11th October, 1897.)

Claim.—1st. A material for an armour for pneumatic tires, composed of two thicknesses of closely woven fabric, with paper between and firmly united together by means of thin sheets of caoutchouc placed between the paper and the fabric, subject to heat and pressure, substantially as and for the purpose specified. 2nd. An armour for pneumatic tires composed of the material described, cut into strips two inches wide and six inches long, and by means of longitudinal slits and transverse openings permitting them to be joined together consecutively by inserting the parts of one strip into the openings of the other and overlap to produce two thicknesses of the material, substantially as and for the purpose specified. 3rd. An armour for pneumatic tires composed of a material made of two pieces of closely woven fabric with paper between, united firmly together by means of thin sheets of caoutchouc placed between the two sides of the paper and the fabric subjected to heat and pressure, the material cut into strips two inches wide by six inches long, the strips slit laterally one inch, at intervals of two inches and transversely on each side of a central strip to permit the parts of one to be inserted into the openings of the other and overlap to double the thickness of the strips, substantially as and for the purpose specified.

No. 58,375. Device for Transmitting Motion or Power.
(*Appareil pour transmettre la force ou le mouvement.*)

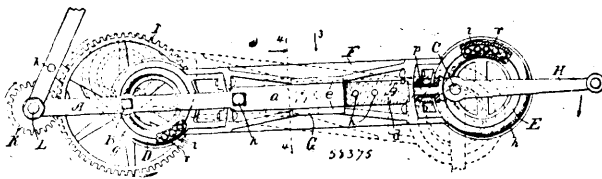

John George Wagner and Herman Samuel Scarle, assignees of Frank Joseph Noechel, both of Rochester, New York, U.S.A., 13th December, 1897; 6 years. (Filed 6th November, 1897.)

Claim.—1st. A device for transmitting power or motion, having a rotatory driving shaft provided with an eccentric bearing, and a rotatory driven shaft provided with an eccentric bearing, in combination with a connecting-rod for said bearings, and means to hold the middle part of said rod substantially in a plane common with the axes of said shafts, the connecting-rod having pivotal motion, substantially as shown and described. 2nd. In a device for transmitting power or motion, the combination with a two-part frame, the central portion of which is provided with parallel parts, and one of the parts of the frame is longer than the other, of a shaft journaled at each end of the frame, an eccentric upon each shaft, a head upon the parallel portion of the frame, and a connector pivotally secured to the head and having its ends connected with the eccentrics, substantially as set forth. 3rd. In a device for transmitting power or motion, the combination, with a two-part frame, the central portion of which is provided with a parallel portion, of a shaft at each end of the frame provided with an eccentric, a two-part head between the parts of the frame, each part of which is provided with means for engaging with the parallel portions of the frame, a pin in the head, an open frame connector provided with a cross-bar pivotally secured upon the pin, the ends of the connector

being connected with the eccentric, substantially as set forth. 4th. In a device for transmitting power or motion, the combination, with a frame, of a shaft journaled at each end thereof, an eccentric upon each shaft, a head upon the central portion of the frame a connector pivotally secured to the head and having its ends connected with the eccentrics, each end of the connector having an opening leading into the space between the eccentrics and the connector, and balls within the space, substantially as set forth. 5th. In a device for transmitting motion or power, the combination with a frame, of a crank at each end thereof, a wheel at one end provided with a hub and spokes, a detachable rim secured to the spokes, a perforated plate upon the spokes, the pin of the crank at that end being connected with said plate, and a pitman having its ends connected with the cranks and the central portion movably connected with the frame, substantially as set forth. 6th. In a motion or power transmitting device, a driving shaft having an eccentric bearing, and a driven shaft having an eccentric bearing, in combination with a connecting-rod for said bearings, a sliding-head having bearings upon the connecting-rod at its middle, and parallel ways for the sliding-head, the connecting-rod being provided with detachable end-pieces, substantially as and for the purpose specified. 7th. In a device for transmitting power or motion, having a frame, and cranks held thereby, in combination with a connecting-rod for said cranks, having a transverse trunnion pin at the middle, projecting from its sides and antifriction rollers on the ends of the trunnion pin, and guides in the frame for said rollers, substantially as set forth.

No. 58,376. Roller Bearing. (*Coussinet anti-frottant.*)

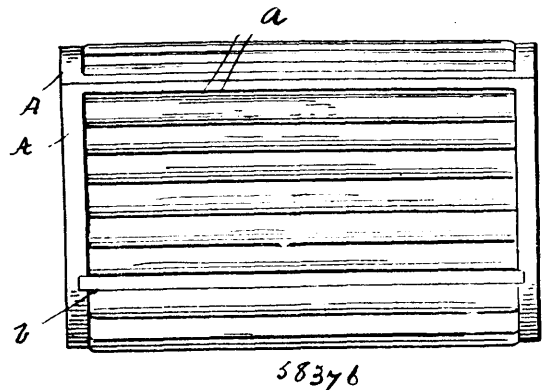

Frank Mossberg, Providence, Rhode Island, U.S.A., 14th December, 1897; 6 years. (Filed 31st July, 1897.)

Claim.—1st. A roller bearing comprising a cage, a series of rollers loosely held within the same, with means for preventing the displacement of the rollers, substantially as described. 2nd. A roller bearing comprising a cage, a series of rollers divided into sets within the cage, and means for preventing the displacement of the rollers, substantially as described. 3rd. A roller bearing comprising a cage having end rings with a groove or depression in the inner faces of said rings and a series of rollers held within the cage and having their ends conforming to the configuration of the grooves in the end rings whereby the displacement of the rollers is prevented, substantially as described. 4th. A roller bearing comprising a cage made in halves, each half being connected centrally by a division piece, sets of rollers located in the spaces between the division pieces, with means for preventing the displacement of the rollers substantially as described. 5th. In combination with a box or casing, a cage located within the same, and a series of rollers located within the cage, said rollers being arranged in contact with each other and loosely supported with means for preventing their displacement, substantially as described. 6th. In combination with a casing or box, a cage, rollers supported within the cage and end caps for the box, grooved and containing a packing, substantially as described. 7th. In combination with a casing or box, a cage, rollers supported within the cage and end caps for the box, substantially as described. 8th. A roller bearing comprising a cage made in halves, division pieces extending between the end sections of the cage and a series of rollers located in the spaces formed by the division pieces, the rollers of each series being in contact with each other.

No. 58,377. Roller Bearing. (*Coussinet anti-frottant.*)

Frank Mossberg, Providence, Rhode Island, U.S.A., 14th December, 1897; 6 years. (Filed 31st July, 1897.)

Claim.—1st. A roller bearing comprising a cage of frusto-conical form and a series of rollers fitted to openings in the wall of said cage, said rollers protruding on each side of said wall, the cage being hollow, whereby a bearing is provided adapted to resist the thrust of the bearing surface both longitudinally and laterally, substantially as described. 2nd. A roller bearing comprising a cage made hollow and in frusto-conical form, the wall of

said cage being provided with a series of openings separated from each other by divisions or webs and a series of rollers fitting said

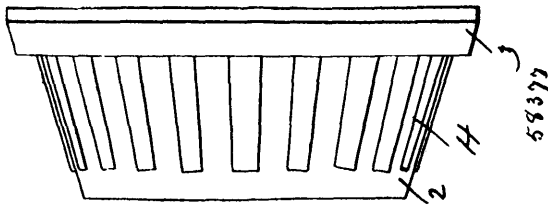

openings and maintained in exact relation to each other by said cage, and an inner and outer bearing for said rollers, substantially as described.

No. 58,378. Railroad Switch Lamp.
(*Lampe d'aiguille de chemin de fer.*)

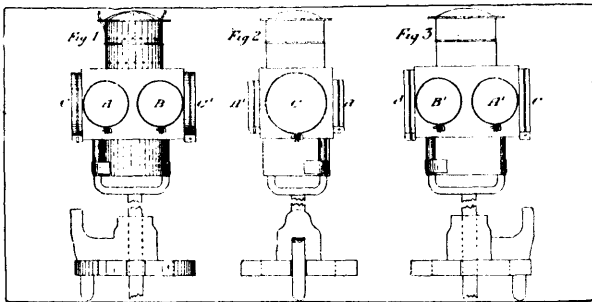

Thomas Jones and Samuel A. Hoke, both of Tacoma, Washington, U.S.A., 14th December, 1897; 6 years. (Filed 7th October, 1897.)

Claim.—A railway lantern, having a plurality of lenses of different colours on two sides of the casing, the lenses of the same colour being located opposite each other, and the colours of the lenses on the opposite side of the casing being reversely arranged.

No. 58,379. Dental Chair. (*Chaise de chirurgie.*)

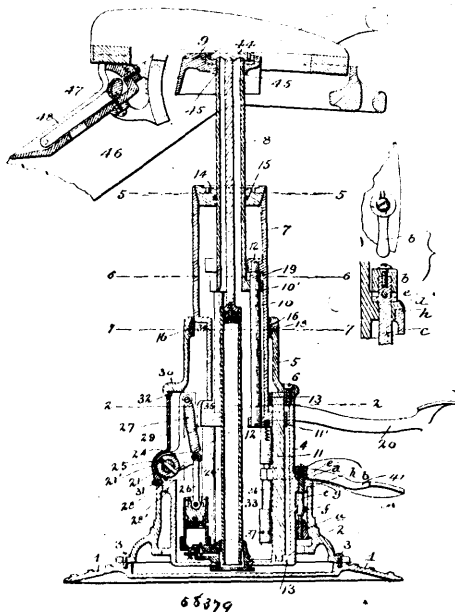

Frank Ritter, Rochester, New York, U.S.A., 14th December, 1897; 6 years. (Filed 5th November, 1897.)

Claim.—1st. In a dental chair, the combination of telescoping tubes, guide rods fixed between the tubes, and tube flanges provided with openings to receive and fit the rods whereby the tubes are guided and steadied and whereby independent rotation is obviated, substantially as described. 2nd. In a dental chair, the combination of telescoping tubes, guide rods fixed to flanges in the movable and fixed pedestal sections and situated interiorly thereof and exterior

tube flanges provided with openings to receive and fit the rods, substantially as described. 3rd. In combination with the elevating mechanism, the telescoping tube 7 having an exterior flange 11' and an interior flange 12, a guide rod fixed in one of the flanges, and a guide rod movable through the other, substantially as described. 4th. In a dental chair, the combination of telescoping tubes having flanges and guide rods and a spring situated between the flanges to prevent jar, substantially as described. 5th. In a dental chair, the combination of the oil tank, the telescoping pedestal sections and the guide rods, said rods and sections being adapted to be lubricated by descent into the tank, substantially as described. 6th. In a dental chair, the combination of the base, the pedestal rotatably supported on said base, the wedge-block situated between the pedestal and base, and block-moving devices to crowd said block against their walls, substantially as described. 7th. In a dental chair, the combination of the base, the pedestal rotatably supported on said base, the wedge-block situated between the pedestal and base, and block-moving devices to crowd said block against their wall, said devices consisting of a screw, a detachable screw turning bar and means for adjusting the bar with respect to the screw, substantially as described. 8th. In a dental chair, a pedestal having an opening or doorway and a cover or door to close the same, substantially as described. 9th. In a dental chair, a pedestal having an opening or doorway and a cover or door 29, said cover being detachably secured to the pedestal and engaging under a rib 32 thereof, substantially as described. 10th. In a dental chair, the combination of an oil holder, a pedestal section adapted to be moved into the holder, a piston tube 33, and a pump, said pedestal section having an inset part 34 to permit it to descend beside the pump, substantially as described. 11th. In a dental chair, the combination of an oil holder, a pedestal section adapted to be moved into the holder, a piston tube 33, and a pump, said pedestal section having an inset part 34 to permit it to descend beside the pump, tube 7 having flanges 12, the tube 8 having flanges 10', said inset being cut away at 35 to permit the tube 8 to be rotated within tube 7 to cause said flanges to register in assembling the parts, substantially as described. 12th. In a dental chair, the combination of the pedestal, the pump, the lever-member 20 fixed to the fulcrum 21 at the exterior of the pedestal, said fulcrum consisting of a rod pivoted in the pedestal wall, the short lever-member consisting of a sleeve secured to the rod and provided with arms, a second rod extending through said arms, a piston-connecting-rod loosely joined to the said second-named rod, and returning springs attached to the latter rod outside its bearings in the arms, substantially as described. 13th. In a dental chair, the combination of a pedestal having a door opening, a lever having its fulcrum situated in the opening and bearing in the pedestal wall, lever-returning springs and a projection 28 arranged to engage the pedestal and arrest the action of the springs, substantially as described. 14th. In a dental chair, the combination of the telescoping pedestal sections and the sectional ring 16 provided with screws for setting the ring against the inner pedestal section, substantially as described. 15th. In a dental chair, the combination of the seat tube, the pedestal and the frusto-conical split plug to adjust the bearing connection of said tube and pedestal, substantially as described. 16th. In a dental chair, the combination of the cross-bar of the seat frame, the seat tube provided with a shoulder, and a nut engaging the tube above the shoulder to fasten the bar on the tube, substantially as described.

No. 58,380. Steam Engine. (*Machine à vapeur.*)

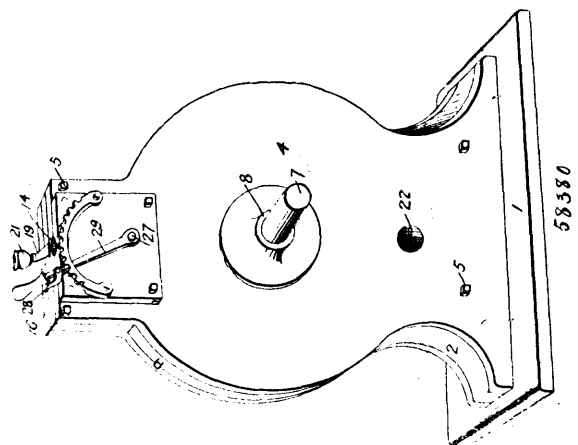

George Exter Woodard, Sugar Grove, Pennsylvania, U.S.A., 14th December, 1897; 6 years. (Filed 16th November, 1897.)

Claim.—A rotary steam engine, comprising the horizontal base 1 and integral frame 2 provided with the transverse cylindrical orifice 3, the exhaust passage 14, the vertical recess 15, and the inlet ports 24 and 25, in combination with the rotary disc piston 6, having the radial recesses 9 and the aligned recesses 10, the springs 13

arranged in said recesses 10, the plungers 12 fitted to the recesses 9, the block 17 mounted in the vertical recess 15, the spring 18 and the cap 19 provided with the oil passage 20 and the oil cup fixed to said cap, the steam-chest formed with the cylindrical chamber 23 and the semi-circular valve 26 mounted in said chamber and arranged to alternately or simultaneously close said ports 24 and 25, substantially as shown and described.

No. 58,381. Shirt. (Chemise.)

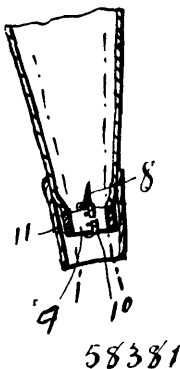

Frederick William Stewart, Montreal, Quebec, Canada. 14th December, 1897; 6 years. (Filed 20th November, 1897.)

Claim.—1st. A shirt having a band located therein to extend over the abdomen and lumbar regions of the wearer, substantially as and for the purposes set forth. 2nd. A shirt having the wrist portions of the sleeves provided with tightening devices, and having cuffs adapted to overlap and enclose said wrist portions, substantially as and for the purposes set forth. 3rd. A shirt having a body portion, a band 5, sleeves 7, bands 9, buckles 10, cuffs 11, the front opening having pieces 15 and 16, stitched as at 17, to the edges thereof, as and for the purpose set forth.

No. 58,382. Reversing Steam Turbine.

(Turbine à vapeur réversible.)

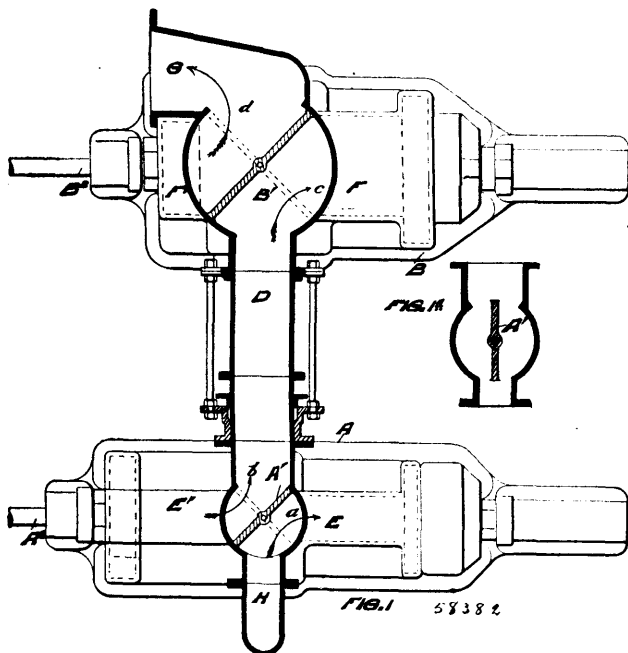

Charles Algernon Parsons, Heaton Works, Newcastle-on-Tyne, Northumberland, and Allan Archibald Campbell Swinton, Westminster, London, both in England, 14th December, 1897; 6 years. (Filed 20th November, 1897.)

Claim.—1st. The method of reversing the direction of rotation of a steam turbine by reversing the direction of flow of the steam through the blades, the same blades being used for actuating the turbine in both directions, as herein set forth. 2nd. A reversing steam turbine, reversed by the method claimed in the preceding claim, and having two, three or more turbines arranged in series or compound parallel on the steam, provided with reversing valves

which may either operate together or reverse the direction of steam flow in one or more of the turbines, substantially as described. 3rd. In steam turbines reversed by the method claimed in the first claim, blades constructed of a moderately concave form, substantially as and for the purposes hereinbefore described. 4th. In steam turbines reversed by the method claimed in the first claim, straight blades to provide equal force in both directions of steam flow, substantially as and for the purposes hereinbefore described. 5th. In steam turbines reversed by the method claimed in the first claim, blades having opposite concavities to secure equal force in both directions of steam flow while providing concave surfaces for the impingement of the steam jets in both directions, substantially as hereinbefore described with reference to figure 5 of the drawings. 6th. In steam turbines reversed as claimed in the first claim, a two-way valve of the butterfly type, so arranged that when placed in either of two extreme positions steam is supplied to the turbine on one side of the valve, and discharged on the other, but in which the direction of flow of the steam through the turbine depends on the particular position, the valve being also arranged so that when in mid-position the steam flows past both sides of the valve and does not flow through the turbines, substantially as described. 7th. In a reversing steam turbine, having a valve or valves as claimed in claim 6, arranging the valve so that while in mid-position it throttles the steam to the same extent as the turbine would, so that the steam is supplied to the next turbine in series as if the turbine which has been cut out were in operation, substantially as hereinbefore described. 8th. The combination of turbines and valves hereinbefore described with any known form of "marine" governor or ordinary governor worked from the engine shaft, the valves being so arranged that each or any number of the turbines can be governed independently for the purpose of preventing racing at sea. 9th. The reversing steam turbines hereinbefore described and illustrated at figures 1 and 6 either with the reversing valves linked together, or operating independently.

No. 58,383. Saw. (Scie.)

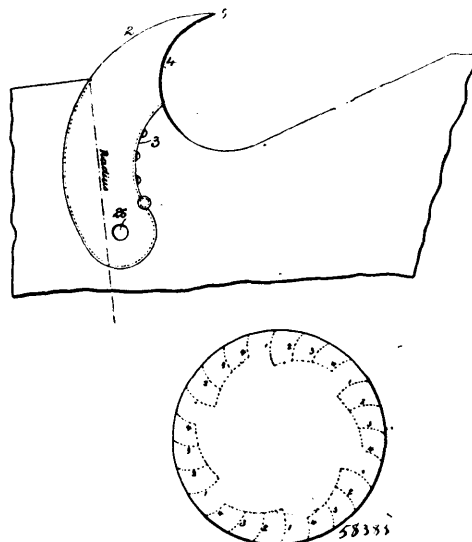

Dewey Phillips, East Arlington, Vermont, U.S.A., 14th December, 1897; 6 years. (Filed 22nd November, 1897.)

Claim.—1st. In a saw having detachable teeth set into and fitting slots formed entirely in the body or main plate of the saw, the removable adjustable teeth each having a convex outer edge extending from the base to the cutting-point or nearly so and a curved inner edge parallel to the convex edge and a concave throat to the point of the tooth, the saw having slots with curved parallel edges corresponding to the teeth and concave recesses in the edges forming continuations of the throats in the teeth, the longitudinal curve of each saw-tooth being subtended by a radius and substantially perpendicular to the intersecting tangent so that the teeth are not liable to be thrown out when in use, and pins for holding the teeth in place, substantially as specified. 2nd. In a saw having detachable teeth set into and fitting slots formed entirely in the body or main plate of the saw, the removable adjustable teeth each having a convex outer edge extending from the base to the cutting-point or nearly so and a curved inner edge parallel to the convex edge and a concave throat to the point of the tooth, the saw having slots with curved parallel edges corresponding to the teeth and concave recesses in the edges forming continuations of the throats in the teeth, the longitudinal curve of each saw-tooth being subtended by a radius and substantially perpendicular to the intersecting tangent so that the teeth are not liable to be thrown out when in use, and notches at uniform distances apart and pins whereby the teeth can be set out progressively, substantially as specified. 3rd.

The combination with the removable saw-teeth, of a saw-plate having notches for the reception of the teeth, such notches varying in depth in regular gradations for the reception of teeth varying in length in similar regular gradations, so that the teeth may be set out from time to time as worn away, by changing the teeth from the deeper into the shallower notches, substantially as set forth.

No. 58,384. Bed. (Lit.)

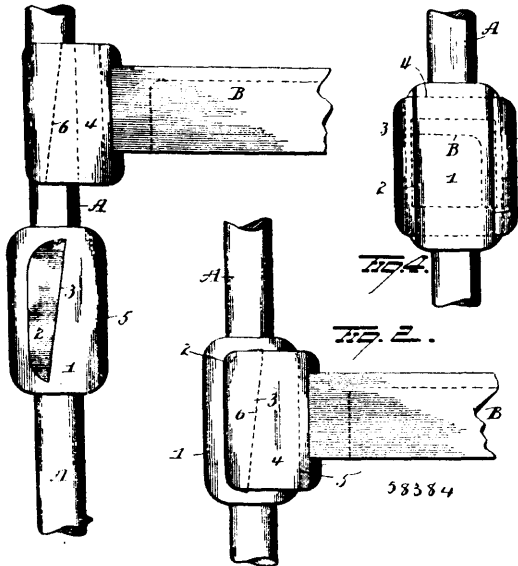

John Kaschenbach, Wilkesbarre, Pennsylvania, U.S.A., 14th December, 1897; 6 years. (Filed 24th November, 1897.)

Claim.—The combination with a post having a curved or cylindrical portion thereon, said curved or cylindrical portion flattened at opposite points and provided with inclined shoulders adjacent to these flattened portions, of a yoke adapted to span this curved or cylindrical portion and provided with inclined shoulders which embrace the shoulders on the post whereby as weight is applied, the bed is drawn tighter and tighter together, substantially as set forth.

No. 58,385. Car Door Fastener.

(Attache de porte de chars.)

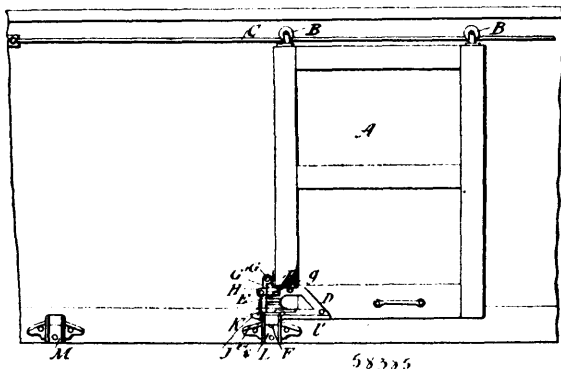

Thomas Tighe, Schenectady, New York, U.S.A., 14th December, 1897; 6 years. (Filed 22nd November, 1897.)

Claim.—1st. A sliding door provided with a casting having a housing for a vertically-moving bolt, a plate secured to the edge of the door, and secured to a lug projecting through the bolt socket, a spring beneath the lug within a recess in the bolt, and bolt-sockets consisting of castings formed with vertical holes for the lower end of the bolt and with oppositely inclined ways for the bolt to ride on. 2nd. The combination with a sliding door, of a casting secured to one corner thereof, and provided with a bolt-housing, a vertically-moving spring bolt therein, and a lateral projection extending from the lower end of the housing and having an inclined under surface for the purpose specified.

No. 58,386. Flax-Threshing Machine.

(Faucheuse pour le lin.)

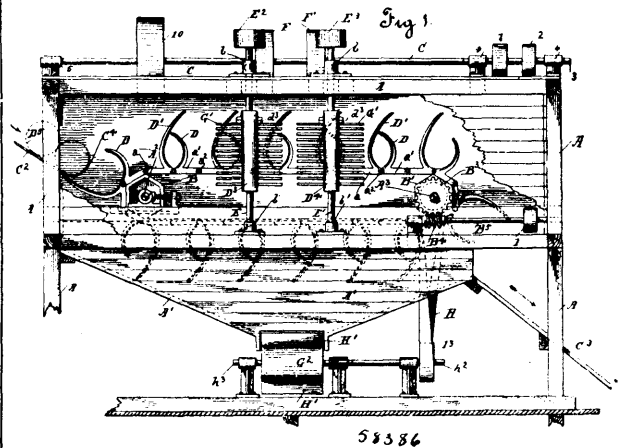

John Switzer, San Francisco, California, U.S.A., 14th December, 1897; 6 years. (Filed 22nd November, 1897.)

Claim.—1st. In a flax-threshing machine, the combination with the horizontally-travelling endless-chain carrier composed of a series of links united by a rule joint, of the end wheels over which said carrier travels, of mechanism for driving one of said wheels, the automatically opening and closing clamping jaws secured to and operated by the travel of the horizontally-travelling endless carrier over the end wheels, said jaws consisting of two curved fingers or arms which are secured to opposing links of the carrier, and of the vertically-arranged rotary threshing devices located between the end wheels, which devices thresh the bundles of sheaves as carried past by the endless carrier. 2nd. In a flax-threshing machine, the combination with the horizontally-travelling endless-chain carrier, said carrier consisting of a series of links united by a rule joint, of mechanism for driving the same, a series of clamping devices for receiving and holding the bundles secured to and carried and operated by the movement of the endless carrier, each clamping device consisting of two fingers or arms secured to opposing links of the carrier, and of devices for threshing the bundles or sheaves as carried by the endless carrier. 3rd. In a threshing machine for flax, the combination with the horizontally-travelling endless-chain carrier, of the end wheels over which the said endless-chain carrier travels, mechanism for driving one of said end wheels, a series of automatically-operated clamping devices for the bundles or sheaves secured to and carried and operated by the movement of the endless carrier, and of the vertically-arranged rotary threshing devices arranged at a right angle to the endless carrier and which during their rotary movement separates the seed from the flax as the bundles are carried past the same, and of mechanism for rotating the threshing devices in opposite directions. 4th. In a flax-threshing machine, the combination of an endless horizontally-travelling chain carrier composed of a series of links or sections united by a rule joint, of the end wheels over which the said carrier travels, a series of clamping jaws composed of two curved arms, each arm being secured to an independent link or section of the endless carrier, mechanism for driving the endless carrier and causing the clamping jaws to automatically close and open in order to clamp the bundles or sheaves and discharge the same, of devices rotating in a plane at an angle to the travelling carrier in order to separate the seed from the flax, and of mechanism for rotating the threshing device in opposite directions. 5th. In a flax-threshing machine, the combination with the horizontally-travelling endless-chain carrier composed of a series of links united by a rule joint, of the end wheels which support and over which the endless-chain carrier travels, a series of automatically opening and closing clamping devices for the bundles or sheaves secured to and carried and operated by the movement of the carrier, each clamping device consisting of a pair of fingers or arms which are secured to opposing links of the carrier, mechanism for driving the carrier, a cylinder arranged at an angle to the endless carrier, mechanism for imparting rotary movement to the cylinder, and of the comb or separating teeth or fingers removably secured to and carried by the said cylinder, which teeth or fingers as carried around engage the head of the bundles or sheaf of flax and remove or separate the seed therefrom. 6th. In a flax-threshing machine, the combination with the endless horizontally-travelling chain carrier, of the end wheels which support and over which the endless carrier works, the clamping devices secured to and carried and operated by the movement of said carrier, mechanism for driving the said endless carrier, a pair of rotating comb cylinders carrying comb teeth or fingers arranged at an angle to the endless carrier, the comb teeth or fingers of which cylinders engage with the head of the bundles held within the clamping devices and separate the seed therefrom, and of mechanism for communicating opposite rotation to the two comb cylinders. 7th. In a flax-threshing machine, the

combination with the endless-travelling carrier composed of a series of links or sections united by a rule joint, of a series of clamping jaws composed of two curved arms, each arm being secured to an independent link or section of the endless carrier, and of mechanism for driving the endless carrier and causing the clamping jaws to automatically close and open in order to receive the bundles or sheaves of flax, clamp the same and discharge the threshed bundles or sheaves therefrom. 8th. In a flax-threshing machine, the combination with the longitudinally and horizontally travelling endless carrier of the automatically opening and closing clamping jaws secured to and carried thereby, the rotating comb cylinders arranged to one side and at an angle to the endless carrier, mechanism for imparting rotary movement to the comb cylinder, and of the comb teeth or fingers removably secured to the comb cylinder.

No. 58,387. Cleaning Device for Water-Closets, Sewers, Sinks, etc. (*Appareil à nettoyer les latrines à eau, etc.*)

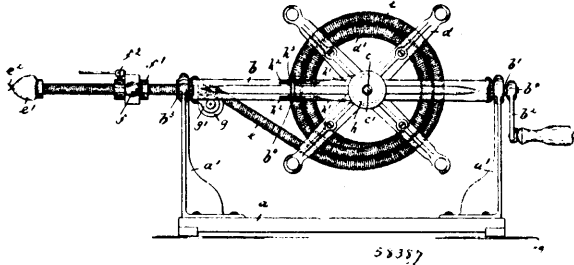

John Wrigley, Elmira, New York, U.S.A., 14th December, 1897; 6 years. (Filed 22nd November, 1897.)

Claim.—1st. A portable cleaning device for sewers, water-closets, chimneys, flues and the like, comprising a revolving frame, a reel revolvably mounted in said frame, and having its axle at right-angles to the axis of the revolving frame, a coil or spiral upon said reel and penetrating said frame approximately in the centre line of its axis, and a tool or implement at the free end of said coil, substantially as and for the purposes described. 2nd. A portable cleaning device for sewers, water-closets, chimneys, flues and the like, comprising a revolving frame, a reel revolvably mounted in said frame, and having its axle at right-angles to the axis of the revolving frame, a coil or spiral upon said reel and penetrating said frame approximately in the centre line of its axis, a tool or implement at the free end of said coil, and a guide-wheel for the coil and carried by the revolving frame, substantially as and for the purposes described. 3rd. A portable cleaning device for sewer, water-closets, chimneys, flues and the like, comprising a revolving frame, a reel revolvably mounted in said frame, and having its axle at right angles to the axis of the revolving frame, a coil or spiral upon said reel and penetrating said frame approximately in the centre line of its axis, a tool or implement at the free end of said coil, and a brake for the reel and carried by the revolving frame, substantially as and for the purposes described. 4th. A portable cleaning device for sewers, water-closets, chimneys, flues and the like, comprising a revolving frame, a reel revolvably mounted in said frame, and having its axle at right angles to the axis of the revolving frame, a coil or spiral upon said reel and penetrating said frame approximately in the centre line of its axis, a guide-wheel for said coil and carried by the revolving frame, and a brake also carried by said frame and adapted to regulate the speed of the reel, substantially as and for the purposes described. 5th. A portable cleaning device for sewers, water-closets, chimneys, flues and the like, comprising a revolving frame, a reel revolvably mounted in said frame, and having its axle at right angles to the axis of the revolving frame, a coil or spiral upon said reel and penetrating said frame approximately in the centre line of its axis, a sleeve loosely arranged on said coil, a set screw in said sleeve, and a handle revolvably mounted on said sleeve, substantially as and for the purposes described. 6th. A portable cleaning device for sewers, water-closets, chimneys, flues and the like, comprising a revolving frame, a reel revolvably mounted in said frame, and having its axle at right-angles to the axis of the revolving frame, a coil or spiral upon said reel and penetrating said frame approximately in the centre line of its axis, a tool or implement at the free end of the coil, and a frame for suitably supporting the revolving frame, substantially as and for the purposes described. 7th. A portable cleaning device for sewers, water-closets, chimneys, flues and the like, comprising a revolving frame, a reel revolvably mounted in said frame and having its axle at right angles to the axis of the revolving frame, a coil or spiral upon said reel and penetrating said frame approximately in the centre line of its axis, a tool or implement at the free end of the coil, a frame for suitably supporting the revolving frame, and means for transmitting the motion from the revolving frame to the reel, substantially as and for the purposes described. 8th. A portable cleaning device for sewers, water-closets, chimneys, flues and the like, comprising a revolving frame, a reel revolvably mounted in said frame and having

its axle at right angles to the axis of the revolving frame, a coil or spiral upon said reel and penetrating said frame approximately in the centre line of its axis, a tool or implement at the free end of the coil, a frame for suitably supporting the revolving frame, a gear-wheel mounted on the axis of the revolving frame, a gear-wheel on the axis of the reel, and intermediate gear-wheels connecting said gear-wheel on the revolving frame with the gear-wheel on the reel, substantially as and for the purposes described.

No. 58,388. Water Purifier for Steam Boilers. (*Epurateur d'eau pour chaudières à vapeur.*)

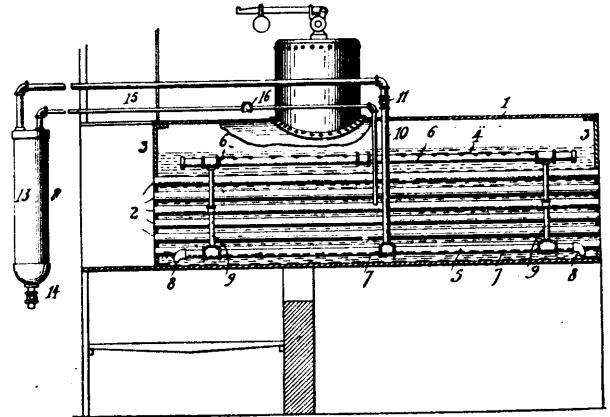

William Irving, Chicago, Illinois, U.S.A., 14th December, 1897; 6 years. (Filed 22nd November, 1897.)

Claim.—An apparatus for purifying the water in steam-boilers comprising in combination a sediment-collecting tube extending longitudinally of the boiler close to the bottom thereof and having perforations in its lower side, a second sediment-collecting tube located near the water-level and having perforations in its upper side, a pipe or pipes connecting said tubes within the boiler, a discharge-pipe or riser connected with the lower of said tubes extending through the boiler-shell and having a valve therein, a sediment-chamber with which said discharge-pipe connects having a valve-controlled sediment-discharge outlet and a return-pipe having a check-valve therein opening toward the discharge end of said pipe, substantially as described.

No. 58,389. Combined Key and Permutation Lock. (*Clé et serrure pneumatique.*)

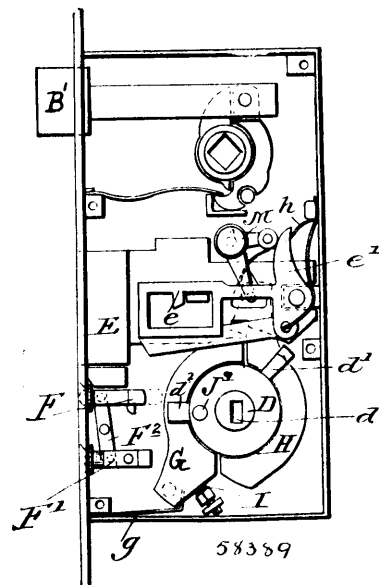

Charles Wichert, Brooklyn, New York, U.S.A., 14th December, 1897; 6 years. (Filed 24th November, 1897.)

Claim.—1st. In a lock, the combination, with the bolt mechanism, and push-pins guided in the casing of the lock, of a rotary barrel provided with means adapted to engage one of said push-pins and

to operate the bolt mechanism, and means in connection with the barrel for converting the lock from an ordinary lock into a combination-lock when said engageable pin is pushed out, substantially as set forth. 2nd. In a lock, the combination, with the bolt mechanism, and push-pins guided in the casing, of a rotary barrel provided with a striker adapted to engage one of said push-pins and operate the bolt mechanism spring-actuated segments enclosing the barrel and provided on their inner faces with grooves or channels and a trap, and a traveller arranged in the barrel and provided with means for engaging in said grooves or channels and passing through said traps, substantially as set forth. 3rd. In a lock, the combination, with the bolt mechanism, and push-pins guided in the casing, of a rotary barrel provided with a striker, spring-actuated segments enclosing the barrel and provided in their inner faces with grooves or channels and a trap, and a traveller guided in a recess in the barrel and provided with antifriction rollers, and with a projecting pin extending into said grooves or channels, substantially as set forth.

No. 58,390. Electric Alarm for Cars.
(*Avertisseur électrique pour chars.*)

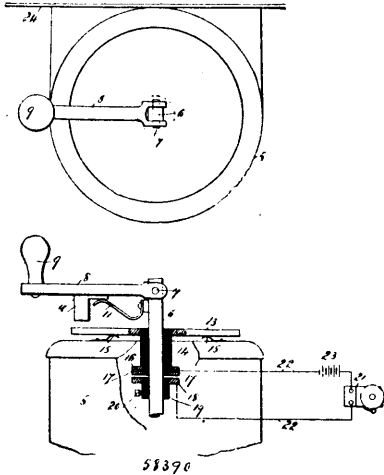

Alexander Nathan, New York, State of New York, U.S.A., 14th December, 1897; 6 years. (Filed 21st July, 1897.)

Claim.—1st. The herein described electric alarm for cars, said alarm consisting of a vertical shaft, a spring supported lever pivotally connected with the upper end thereof, and provided with a downwardly directed arm, a vertically movable disc or plate mounted on said shaft below said lever, a disc or plate mounted below said vertically movable disc or plate, and connected and vertically movable therewith, a disc or plate rigidly secured to said shaft below said last-named disc or plate, and an alarm bell in electrical connection with said last-named discs or plates, substantially as shown and described. 2nd. An electric alarm for electric cars, consisting of a lever pivotally connected with the upper end of the shaft by which the motor of the car is operated, said lever being spring supported, and provided with a downwardly directed arm, a spring supported plate mounted on said shaft below said lever, and insulated from said shaft by a sleeve, a disc plate connected with said sleeve and vertically movable therewith, and with said spring supported disc or plate, a disc or plate mounted on said shaft, and secured thereto, and insulated therefrom below said last-named disc or plate, and an electric bell in circuit with said last-named discs or plates, substantially as shown and described. 3rd. An electric alarm for cars, consisting of a vertical shaft, a spring supported disc or plate mounted thereon, and insulated therefrom by means of a sleeve a disc or plate connected with the lower end of said sleeve, another disc or plate mounted on said shaft below said last-named disc or plate and insulated from said shaft, and an electric bell in circuit with said last-named discs or plates, substantially as shown and described.

No. 58,391. Temporary Binder. (*Reliure temporaire.*)

Truman Noble, Ithaca, New York, U.S.A., 14th December, 1897; 6 years. (Filed 14th October, 1897.)

Claim.—1st. In a temporary binder, complementary members normally secured by means of an interlocking joint and readily separable, each adapted to receive the papers, and having their sides flush at the joint, and one member having a terminal portion to enter a depression in the terminal of the opposite member, and having a cleft extending for a short distance from its extremity, providing spring members at all times accessible to be pressed between the fingers for releasing the interlocking joint, substantially as set forth. 2nd. In a temporary binder, a base plate, and a holder comprising similar or complementary parts having their

upper end portions bent towards each other and separable at a middle point, one of the parts being rigidly attached to the base

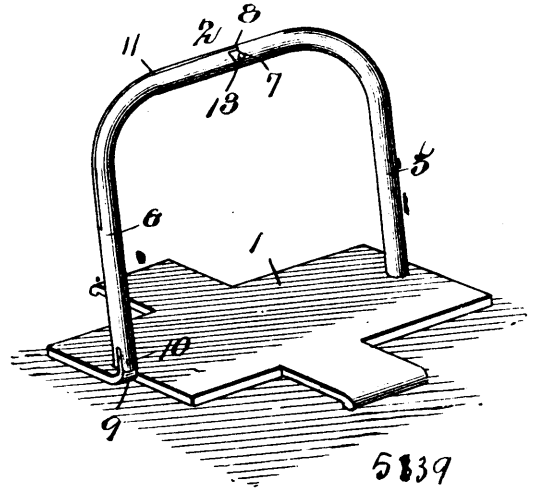

plate and the other part having a pivotal connection therewith, and an interlocking joint provided between the meeting ends of the parts by having a notch or socket in the end of one part and a cleft in the end of the other part, providing spring members whose ends are reduced and formed with lateral extensions to engage positively with the notched or socketed end of the other part, substantially in the manner set forth. 3rd. In a temporary binder, complementary members relatively movable towards and from each other to receive the papers on either one, and normally held together by an interlocking joint, one member having a socket or notch and the opposite member having its terminal portion reduced to enter the depressed extremity of the other member, to interlock therewith, and having the sides of the two members flush at the joint, and the last member having a cleft extending through its reduced terminal, forming spring members or parts which are at all times accessible to be pressed together between the fingers to admit of the interlocking joint being released, substantially as set forth. 4th. In a temporary binder, a base plate having a portion bent at right angles thereto, a member rigidly attached to the base plate, and a complementary member pivoted to the said bent portion of the base plate and having its free end constructed to interlock with the free terminal of the fixed member, and having its end cleft, forming spring parts, substantially as and for the purpose set forth. 5th. In a temporary binder, a base plate provided with anchoring points and having a portion bent at right angles thereto, and a holder comprising a member rigidly attached to the base plate and a second member pivoted to the aforesaid bent portion, the fixed member having a notch or socket, and the pivoted member having its end constructed to enter the said notch or socket and adapted to interlock therewith, and cleft, providing spring parts, substantially as and for the purpose set forth.

No. 58,392. Manufacture of Zinc Pigments.
(*Fabrication de mordant de zinc.*)

Wilhelm Hampe, Clausthal, Hanover, Germany, 15th December, 1897; 18 years. (Filed 6th April, 1897.)

Claim.—The herein described method or process of obtaining pigments, consisting in preparing an intimate mixture of dehydrated sulphates of zinc and of one or more of such metals as form oxides which, when heated with zinc oxide, impart a colour to it, thoroughly commingling the mixture so prepared with finely comminuted carbon, and subjecting the whole to a carefully gauged temperature of 650° C., substantially as described.

No. 58,393. Method of and Apparatus for Bleaching Linseed Oil. (*Méthode et appareil pour blanchir l'huile de lin.*)

Richard William English, Buffalo, New York, U.S.A., 15th December, 1897; 6 years. (Filed 7th May, 1897.)

Claim.—1st. An improved mode of bleaching linseed oil, which consists in subjecting a continuous flow of oil to the bleaching influence of heat. 2nd. An improved mode of bleaching linseed oil, which consists in subjecting a stream of oil to the influence of bleaching heat during its flow through a suitable apparatus. 3rd. The herein described mode of bleaching linseed oil, which consists in projecting a continuous flow of oil against a bleaching heat supplying surface located below the surface of previously bleached oil, as described. 4th. The herein described mode of bleaching linseed oil, which consists in projecting the oil against a bleaching heat supplying surface and allowing it to flow from said bleaching surface into a receiving vessel. 5th. The combination in a linseed oil

bleaching apparatus, of an oil reservoir, a bleaching tank connected with a furnace, a pipe connecting the oil reservoir with a pipe

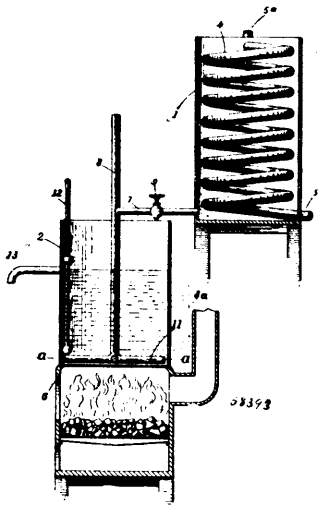

extending into the bleaching tank and communicating therewith, an oil spreading device connected with the pipe in the bleaching tank and located near the bottom of the same, and means for controlling the flow of oil to the bleaching tank. 6th. The combination in a linseed oil bleaching apparatus, of an oil reservoir, a bleaching tank having an outlet near the top, a furnace for supplying the heat located under the bleaching tank, a pipe having one end connecting with the oil reservoir near the bottom and its opposite end connecting with a pipe having its upper end open and its lower end extending down into the bleaching tank to near the bottom of the same and provided with an oil spreading device, for the purpose described.

No. 58,394. Ore Extracting Process.

(Procédé pour l'extraction de l'or.)

Alfred Edward Morgans, Broad Street House, London, England, 15th December, 1897; 6 years. (Filed 10th December, 1895.)

Claim.—1st. In the process of extracting precious metals from their ores, first crushing the ore, then adding a solvent consisting of chloro-cyanogen thereto, so that it will percolate slowly through the mass, with or without an electric current to facilitate action, and finally drawing off the solution so that the metal may be recovered therefrom, substantially as described and for the purpose set forth. 2nd. In the process of extracting precious metals from their ores, first crushing the ore while dry, then adding a solvent consisting of chloro cyanogen thereto, introducing free cyanogen or free chlorine to the compound with or without an electric current to facilitate action, and finally drawing off the solution so that the metal may be recovered therefrom, substantially as described and for the purpose set forth.

No. 58,395. Hydrant. (Borne-fontaine.)

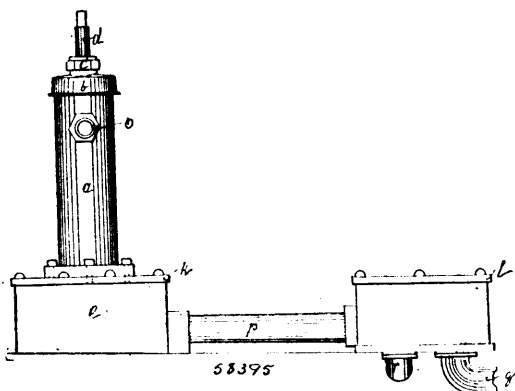

François-Xavier Caron, Montréal Québec, Canada, 15 décembre 1897; 6 ans. (Déposé le 27 septembre 1897.)

Résumé.—1°. Dans une borne-fontaine, la combinaison de la tige *d* avec le disque *u* et le pivot qui l'accompagne, ainsi que le tube *a* avec rebord dans la partie inférieure, tel que ci-dessus décrit et

pour les fins indiquées. 2°. Dans un eborne-fontaine, la combinaison de la boîte *c* avec le gignon *f*, la plaque *z*, la tige à crémaillère *h* et la tige *i* traversant le tuyau *p*, tel que ci-dessus décrit et pour les fins indiquées. 3°. Dans une borne-fontaine, la combinaison de la boîte *j* avec la soupape *m* reliée à la tige *i*, les coulisseaux *n* et les trous *s* et *l*, tel que ci-dessus décrit et pour les fins indiquées. 4°. Dans une borne-fontaine, la combinaison des tuyaux *q* et *r* en relation avec la boîte *j*, tel que ci-dessus décrit et pour les fins indiquées.

No. 58,396. Treatment of Ores. (Traitement des minerais.)

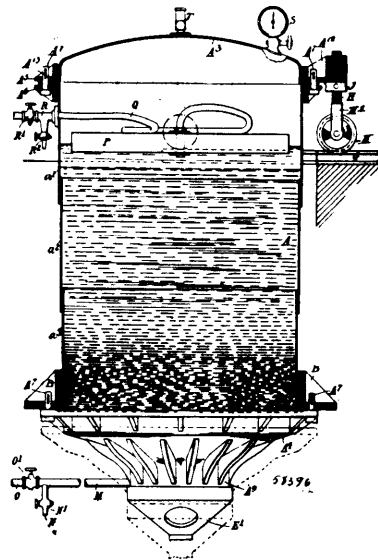

William Adolph Koneman and William Henry Hartley, London, England, 15th December, 1897; 6 years. (Filed 4th March, 1897.)

Claim.—1st. In the treatment of ore in a granular or pulpy condition, subjecting a mixture of ore and liquid in a receptacle to air pressure whereby the ore is compacted into a solid mass at the bottom and the liquid separated out at the top. 2nd. In the treatment of ore in a granular or pulpy condition for the extraction of precious metals contained therein, subjecting a mixture of such ore and a solvent solution in a receptacle to air pressure whereby the ore is compacted into a solid mass at the bottom and the solution containing the precious metals is separated out at the top. 3rd. Re-covering precious metals from ores which are in a granular or pulpy condition, consisting in suitably mixing and treating the solvent solution and the ore, subjecting the mixture in a receptacle to a high air pressure whereby the ore is compacted at the bottom into a dense mass and the clear solution containing the precious metals separated out at the top and forced out of the receptacle by the pressure within, substantially as described. 4th. In the treatment of ore in a granular or pulpy condition which has been compacted by pressure, subjecting the compacted mass of ore to an air and water pressure from below for the purpose of breaking up the mass, substantially as and for the purpose described. 5th. The complete process for the treatment of ores in a granular or pulpy condition consisting in mixing with the ore a suitable solvent solution, subjecting the mass in the receptacle to high air pressure whereby the ore is compacted at the bottom and the clear solution containing the precious metals separated out at the top and automatically ejected by the pressure within, breaking up the compacted mass by air and water pressure from below and repeating the process for the further recovery of the gold-bearing solution, the mass being again compacted and then ejected from the apparatus by pressure from above, substantially as described. 6th. In apparatus of the kind described the employment of a water-bottom with a filter layer, below which latter, water pressure is admitted to prevent the passage of ore through the layer. 7th. The combination with a receptacle such as *A*, of a float *P*, flexible pipe *Q*, and draw-off cock, substantially as described. 8th. The combination with a tank cover such as *A*³, of jacks connected therewith and a track at a lower level than the cover, operating substantially as described. 9th. The combination with a removable tank bottom such as *A*⁴, of a trolley and a holder adapted to rise and fall, substantially as described. 10th. The combination with a tank, of a cover such as *A*³, and a tank bottom such as *A*⁴, each provided with means for lateral removal, substantially as described. 11th. The combination with a tank having a movable bottom, of a cover removable laterally, substantially as described. 12th. In apparatus of the kind hereinbefore referred to, the employment of a sheet or cover for use in the expulsion of the compacted charge, substantially as described.

No. 58,397. Amalgamator. (Amalgamateur.)

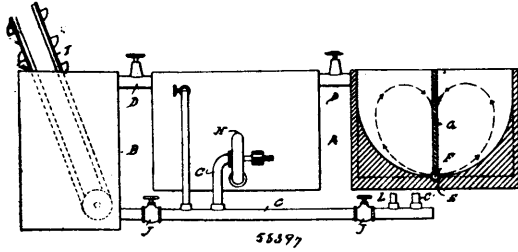

Wilfred L. Brown, San Francisco, California, U.S.A., 15th December, 1897; 6 years. (Filed 27th September, 1897.)

Claim.—1st. In an amalgamator, one or more tanks having curved sides and amalgamating plates fitted thereto, a pipe extending axially between the lower edges of the plates having inclined perforations made therein, a vertical partition extending upwardly from the pipe and from one end of the tank to a point near the other leaving an open channel at this end, a device whereby pulp may be impelled through the angular openings of the pipe whereby it is caused to impinge against the amalgamating plates upon each side of the partition with a spirally revolving movement in each of the chambers, a discharge passage leading from one of said chambers to a succeeding settling tank through which the circulation may be continued. 2nd. In an amalgamator, one or more amalgamating tanks having curved amalgamating plates in the bottom, a centrally located pipe extending longitudinally through the lower part of the tank having oppositely inclined openings upon its opposite sides, a vertical partition extending upwardly from the pipe and extending from one end of the amalgamating chamber to near the other, whereby the material is allowed to pass from one side to the other of the partition, a settling tank connecting with amalgamating tanks, intermediate forcing mechanism by which the material is forced through the perforated pipes of the amalgamators and given a spirally revolving motion in each of the chambers, connecting pipes whereby the surplus material flows successively from one amalgamating chamber to the next of the series, and thence returns to the supply tank whereby a continuous circulation of the material is produced through the entire apparatus. 3rd. In an amalgamator, a series of amalgamating tanks with connecting pipes, central longitudinal partitions and circulating pumps as shown, intermediate gates by which the tanks may be isolated from each other, and pipes extending from the main circulating pipes to the upper parts of the tanks, with controlling gates whereby an independent circulation may be induced in each of the tanks.

No. 58,398. Bait Holder. (Porte-appât.)

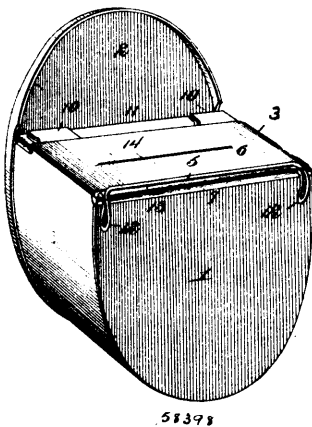

John F. Webber, Sheridan, Wyoming, U.S.A., 15th December, 1897; 6 years. (Filed 2nd November, 1897.)

Claim.—1st. A bait box, having a cover formed of an elastic diaphragm provided with a dividing slit, substantially as and for the purpose specified. 2nd. A bait box, having a cover comprising a wire frame hinged to the box, and an elastic diaphragm secured to the frame and provided with a dividing slit, substantially as and for the purpose specified. 3rd. A bait box, having a cover comprising a wire frame hinged to the box and provided with locking catches, and an elastic diaphragm secured to the frame and provided with a dividing slit, substantially as and for the purpose specified. 4th. A bait box, having a cover, comprising a wire frame hinged to the box

and provided with locking catches, and an elastic diaphragm formed of two pieces of rubber secured to the frame and arranged side by side in close proximity to each other, substantially as described.

No. 58,399. Combined Ink-Well and Pen Holder. (Encrier et porte-plume.)

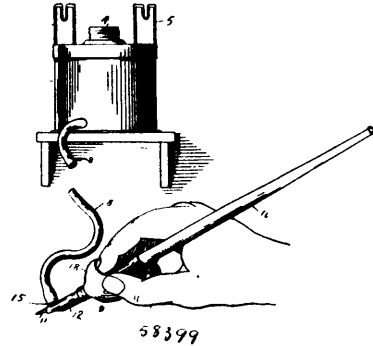

William B. North, West Plains, Missouri, U.S.A., 15th December, 1897; 6 years. (Filed 3rd November, 1897.)

Claim.—1st. In a device of the character set forth, the combination with an ink-well, a solid pen-holder separate from and adapted to be moved independently of said ink-well, and a flexible tube connecting said ink-well and said pen-holder whereby a constant supply of ink is furnished to said pen-holder when the same is in its operative position. 2nd. In a device of the character set forth, the combination of an ink-well, a pen-holder, means for securing the pen-point in said holder, a tubular cap upon the outer end of the handle of said pen-holder surrounding said pen-point, and a flexible rubber tube connecting said ink-well and said tubular cap, substantially as and for the purpose described. 3rd. In a device of the character set forth, the combination of an ink-well having a nipple upon its lower end with an opening therethrough leading into said well, a pen-holder, means for attaching the pen-point to said holder, a tubular cap fitting the forward end of said pen-holder surrounding the pen-point therein, a nipple upon said cap, and a flexible outer tube whose outer ends are attached to the nipples on said ink-well and said cap, substantially as and for the purpose described. 4th. In a device of the character set forth, the combination with an ink-well having a bracket or support for a pen-holder, upon the upper side thereof, a nipple upon its lower end having an opening there-through leading into said well, of a pen-holder means for securing the pen-point in said holder, a tubular cap fitting the outer end thereof and surrounding said pen-point, a nipple upon said cap having an opening therethrough, and a flexible tube secured to the nipples upon said ink-well and said cap, substantially as and for the purpose described.

No. 58,400. Thrust Bearing for Propeller Shafts. (Butée pour arbres de propulsion.)

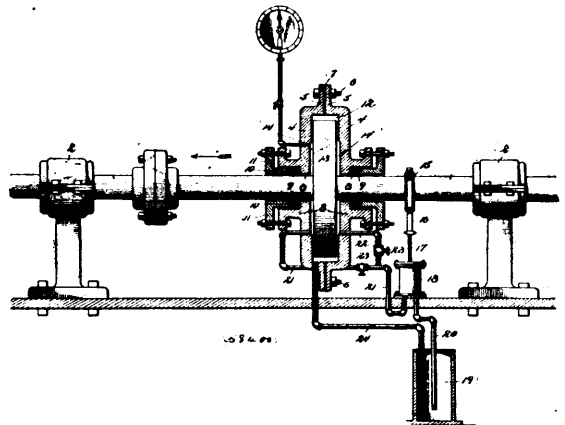

Owen F. Cook, San Jose, California, U.S.A., 15th December, 1897; 6 years. (Filed 8th November, 1897.)

Claim.—1st. In a thrust bearing, the combination with the shaft and the collar rigid thereon, of a casing enclosing the collar, the chamber of said casing being of larger dimensions than the collar to permit the latter to rotate therein without frictional contact, said

casing having annular recesses in its opposite faces, said recesses being of less diameter than that of the collar and forming a closed chamber when the collar frictionally engages the inner face of the casing in which said recess is formed, an oil tank, a pump operated by the shaft and having a pipe connection with the tank, a pipe leading from the pump to said recesses, and a pipe leading from the interior of the casing to the tank, substantially as and for the purpose specified. 2nd. In a thrust bearing, the combination with the shaft and the collar rigid thereon, of a casing enclosing the collar, the chamber of said casing being of larger dimensions than the collar to permit the latter to rotate therein without frictional contact, said casing having annular recesses in its opposite faces, said recesses being of less diameter than that of the collar and each forming a closed chamber when the collar frictionally engages the inner face of the casing in which said recess is formed, and means substantially as described to circulate oil under pressure through the chamber and cause it to accumulate in the recesses whereby an oil cushion is formed, substantially as and for the purpose described. 3rd. In a thrust bearing, the combination with the shaft and the collar rigid thereon, of a casing enclosing the collar, the chamber of said casing being of greater diameter than the collar to leave an annular space between them, said casing having a recess formed in the inner face thereof at each side of the collar, an oil tank, a pump operated by the shaft, a pipe leading from the tank to the pump, pipes leading from the pump to said recesses, valves in the last-named pipes to control the flow of oil therethrough, and a return pipe leading from the annular space in the casing to the oil tank, the construction being such that by operating the said valves the oil can be pumped to either of the recesses and pass into the said annular space to be returned to the tank, substantially as described.

No. 58,401. Hernial Truss. (Bandage herniaire.)

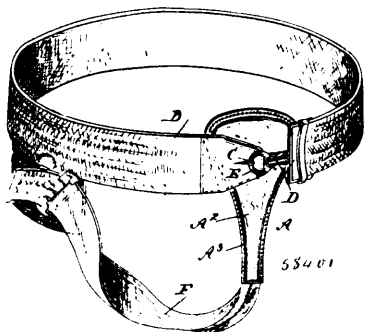

William Barnard Starbuck, Nantucket, Massachusetts, U.S.A., 15th December, 1897; 6 years. (Filed 11th November, 1897.)

Claim.—A truss, comprising a pear-shaped pad provided with a ring secured thereto by an eye or staple, a belt having an opening in one end through which the ring is passed to secure the strap to the pad, the other end of the strap being provided with a hook which after the belt is passed around the body of the wearer engages the said ring, and a leg-strap secured to the smaller end of the pad and adapted to be connected to the belt at one side, substantially as described.

No. 58,402. Method of Making Celluloid Articles.

(Méthode de faire des objets en cellulose.)

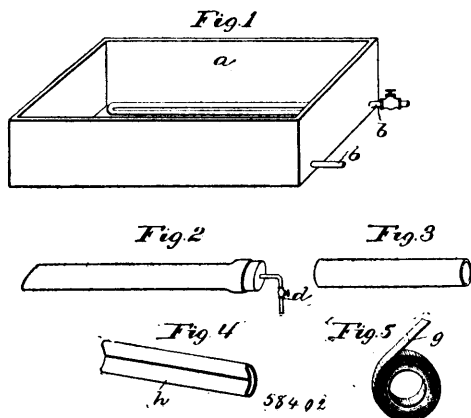

Charles Frederick Church, Newark, New Jersey, U.S.A., 15th December, 1897; 6 years. (Filed 3rd November, 1897.)

Claim.—1st. The within described process of providing an article with a projecting layer of celluloid or like material which includes

as one step the covering of the article and layer with an inner shield of flexible material and subjecting the whole to heat and pressure, all substantially as described. 2nd. The within described process of providing an article of wood or metal with a protecting layer of celluloid or like material which includes as one step in the process covering the article and layer with an inner shield of flexible material and subjecting the whole, while enclosed in an air-tight bag, to heat and pressure, all substantially as described. 3rd. The within described process of providing an article with a thin surface layer of celluloid or like material which includes the alternate heating under pressure and subsequent cooling of the articles with the layer of celluloid protected by an inner shield of flexible material, all substantially as described. 4th. The process of producing an article with a surface layer of celluloid or like material intimately united to the article, which process comprises as steps therein shaping the film or layer to the surface by heat and pressure, then treating the article or the layer with a coat of adhesive material, then enclosing the article and layer in an inner shield of flexible material, then placing these parts in an enclosing bag, and then subjecting the whole to heat and pressure, all substantially as described. 5th. That improvement in the art and process of providing an article of wood with a surface layer of celluloid or like material securely and intimately united to the article which comprises the use of an inner shield of flexible and elastic material about the covered surface of the article while it is subjected to heat and pressure within an enclosing bag and a closed retort filled with liquid, all substantially as described. 6th. The improved process of covering with a thin film of celluloid or like material the irregular surface of an article which consists in first providing a blank film of the size and outline of the surface when developed, and providing for a lap at the seam, then forming the blank to shape by the application of heat and pressure in a protecting bag and setting the blank by cooling, then wrapping the formed blank about the article, then placing thereon an inner shield of flexible and elastic material, then enclosing these parts in an air-tight bag, and then subjecting the whole to heat and pressure in a retort filled with fluid and subsequently cooling the article, all substantially as described.

No. 58,403. Prospecting Quartz Mill.

(Moulin à quartz pour prospecteurs.)

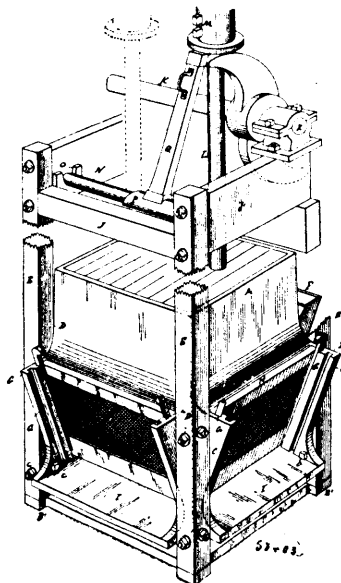

Samuel J. Hendy, San Francisco, California, U.S.A., 15th December, 1897; 6 years. (Filed 26th August, 1897.)

Claim.—1st. In a quartz crushing mill, a four-faced mortar cast integrally with its bed and having its faces inclined outwardly and upwardly from the bottom. 2nd. In a quartz crushing mill, a four-faced mortar cast in one piece with its bed, having its faces inclined outwardly, and its sides projecting at right angles so as to form angular channels for the reception of the corner posts of the mill frame. 3rd. In a quartz crushing mill, a four-faced mortar, cast in one piece with its bed, having its faces inclined outwardly from the bottom, its sides projecting at right angles so as to form corners for the reception of the corner posts of the battery frame, guide channels cast in the projecting sides of the mortar at each of its discharge faces and adapted to hold screens covering the discharge openings, and guides parallel thereto adapted to hold splash boards in front of the screens. 4th. The combination in a quartz crushing mill with the stamp stems and tappets, of removable brace bars with segmental bases adapted to fit on a shaft resting on bearings fixed to two sides of the mill frame and extending underneath the tappets

so as to support them above the reach of the cams. 5th. The combination in a quartz mill, of a mortar having outwardly inclined discharge faces on the lower portion of the sides, said faces forming vertical angular channels between them, a base cast integral with the mortar having corners extended beneath the channels to support the battery frame posts, said posts being also bolted transversely to the mortar sides.

No. 58,404. Waterproofing. (Matière à l'épreuve de l'eau.)

Charles R. Smith, Menasha, Wisconsin, U.S.A., 15th December, 1897; 6 years. (Filed 2nd December, 1896.)

Claim.—1st. A waterproofing material consisting of corn oil and a gummy or resinous substance, substantially as set forth. 2nd. A waterproofing compound consisting of corn oil, linseed oil and a gummy or resinous substance, substantially as set forth. 3rd. A waterproofing compound consisting of corn oil and rosin, substantially as set forth. 4th. The process of waterproofing fibre or other material, consisting in first coating the article with a compound consisting of corn oil and a gummy or resinous substance, then baking or drying, then coating with a compound consisting of corn oil, linseed oil and a gummy or resinous substance, and then baking or drying.

No. 58,405. Toboggans. (Tobaganna.)

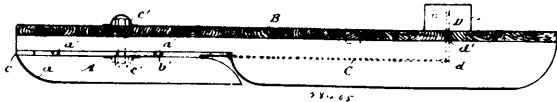

Arthur Alexander Herd, Folkestone, Kent, England, 16th December, 1897; 6 years. (Filed 20th November, 1897.)

Claim.—1st. In toboggans, a steering bogie situated under the fore-part of the toboggan and operated or guided from the toboggan itself, substantially as and for the purposes described. 2nd. In toboggans, a steering bogie provided with rods acting as traces and operated from the toboggan by means of a directing handle for the purpose of guiding the toboggan in its travel, substantially as described. 3rd. In steering bogies for toboggans, as claimed in the preceding claims, guides and rollers attached to the fore-part of the toboggan and its bogie, for the purposes and as described.

No. 58,406. Underfeed Stoker. (Chauffeur mécanique.)

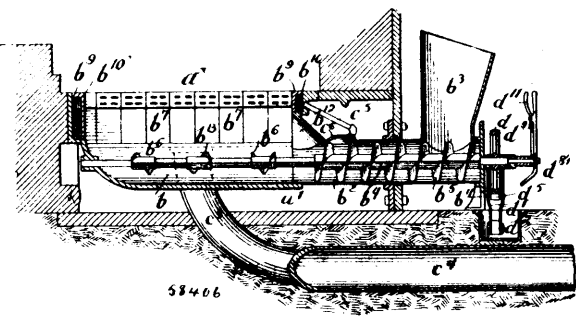

Arthur F. Brown, Dayton, Ohio, U.S.A., 16th December, 1897; 6 years. (Filed 8th November, 1897.)

Claim.—1st. In an underfeed stoker, a fuel-hopper, a horizontal conduit leading from said hopper, and a feeding chamber or magazine having a curved bottom forming a substantial continuation of said conduit and provided with inclined sides and of a substantially uniform width, a screw conveyer extending from said hopper through said conduit and through the bottom portion of said magazine, and an angularly-arranged passage formed in said conduit and extending upwardly therefrom so as to communicate with the front of said magazine above the mouth of said conduit, substantially as specified. 2nd. In an underfeed stoker, a feed-magazine having air-trunks formed on each side thereof and removable twyer-blocks with openings at the top, said twyer-blocks being cored out and formed substantially L-shaped in cross-section so as to extend over and protect the inner side and top of said air-trunks, substantially as specified. 3rd. The combination with a feeding chamber or magazine having the air-trunks on the sides thereof, and devices for feeling the fuel into the bottom of said magazine, of removable plates surrounding said magazine at or near the top, said plate being formed in the nature of twyer-blocks and adapted to extend over the top and inner sides of said air-trunks, substantially as specified. 4th. The combination with the fuel-hopper and a conduit, a conveyer extending through said conduit, a ratchet-wheel on the conveyer shaft and a bearing support for said shaft, a hand-lever journaled concentric with said shaft and carrying at one end a circular track adapted to project over said

ratchet-wheel, and a stationary notched segment connected to said bearing-support, and a holding pawl on said lever for engaging said notched segment so as to hold said track in different positions of adjustment, substantially as specified. 5th. The combination with a fuel-magazine, a conduit leading thereto, and a conveyer in said conduit, said conveyer having flights of varying carrying capacity in the length thereof, and means, substantially as described, for moving said conveyer-shaft longitudinally through said conduit and magazine so as to vary the distribution caused by the varying carrying capacity of said conveyer, substantially as specified. 6th. The combination with a fuel-magazine and a conduit leading thereto, a conveyer in said conduit, said conveyer having a substantially uniform carrying capacity through said conduit and having flights with a reduced carrying capacity within said magazine, and a movable sleeve for supporting the end of said conveyer-shaft, and means, substantially as described, for adjusting said sleeve in different positions to change the longitudinal position of said shaft, substantially as specified. 7th. The combination with a conveyer shaft having conveyer-flights of different carrying capacity, a conduit in which said shaft operates, and a magazine connected to said conduit, of a screw-threaded sleeve, a supporting-bearing for said sleeve, and antifriction bearing-plates in said sleeve, said sleeve being adapted to form a bearing for the front end of said shaft, substantially as specified. 8th. The combination with a fuel-chamber, and a conduit leading thereto, said fuel-chamber being formed with inclined sides and a curved bottom which forms a substantial continuation of said conduit, a conveyer extending through said conduit and fuel-magazine, and having a substantially uniform carrying capacity in said conduit and a reduced carrying capacity in said magazine, and an angularly arranged passage-way formed in said conduit and leading from the top thereof so as to open into the front of said magazine and above said conduit, substantially as specified. 9th. The combination with a fuel-magazine, and a conduit leading horizontally into the same, said magazine being formed of a substantially uniform width with inclined sides and a curved bottom adapted to form a substantial continuation of said conduit, a conveyer extending through said conduit and magazine, and having a substantially uniform carrying capacity in said conduit, and provided with flights of a reduced carrying capacity in said magazine, a vertical angular passage-way formed at the top of said conduit of a width less than the diameter of said conduit and adapted to extend into the front of said magazine, substantially as specified. 10th. The combination with a fuel-magazine, and a conduit leading horizontally into the same, a conveyer-shaft extending through said conduit and through the bottom of said magazine, said shaft having a conveyer of substantially uniform carrying capacity through said conduit, and of a reduced carrying capacity within said magazine, an angularly-arranged passage from the top of said conduit into the front of said magazine, and means as described for adjusting the shaft and conveyer longitudinally through said conduit and magazine, substantially as specified. 11th. The combination of a fuel-magazine, and a conduit leading into the same, a conveyer in said conduit, and twyer-openings in said magazine, an air-trunk connected to said twyer-openings, and an air-passage from said air-trunk communicating with said conduit in front of said magazine so as to form a draft from said conduit into said magazine, substantially as and for the purpose specified. 12th. The combination with a magazine, and a conduit having feeding devices therein, twyer-openings in said magazine, and an air-trunk communicating with said twyer-openings, an air-passage communicating with said conduit at an angle thereto, and a connection from said air-passage to said air-trunk, substantially as specified. 13th. The combination with a magazine and a conduit leading thereto, a conveyer in said conduit, and twyer-openings in said magazine, an air-trunk communicating with said twyer-openings, and an air-passage from said trunk to the conduit, said air-passage being adapted to enter said conduit at an angle thereto, and into a concave pocket formed in said conduit, substantially as specified. 14th. The combination with a fuel-magazine and a conduit leading thereto, said conduit being provided with a circular concave pocket therein, twyer-openings in said magazine, and an air-trunk communicating therewith, a passage from said air-trunk to said concave pocket in said conduit, substantially as specified.

No. 58,407. Underfeed Stoker. (Chauffeur mécanique.)

David F. Graham, Springfield, Massachusetts, U.S.A., 16th December, 1897; 6 years. (Filed 8th November, 1897.)

Claim.—1st. The combination with a fuel magazine having a curved bottom, and a conduit leading laterally therefrom, said conduit consisting of a pipe of uniform diameter whose axis corresponds to the axis of the curved portion of the magazine, a hopper connected with said conduit, and a screw conveyer extending from said hopper centrally through said conduit into said magazine, said conveyer being formed of a uniform carrying capacity within said conduit and of a reduced carrying capacity within the magazine, substantially as specified. 2nd. The combination with a magazine, a fuel-hopper and a horizontal conduit, as described, said conduit being of a uniform diameter and located between the hopper and magazine so as to form substantial continuation of the bottom of each, a screw conveyer extending from said hopper through said conduit into said magazine, and adapted to fit said conduit, said

conveyer being provided with a uniform carrying capacity through the conduit and of a reduced carrying capacity in the magazine,

outer faces of the same at some distance from their edges extending their entire length and provided with a series of registering holes,

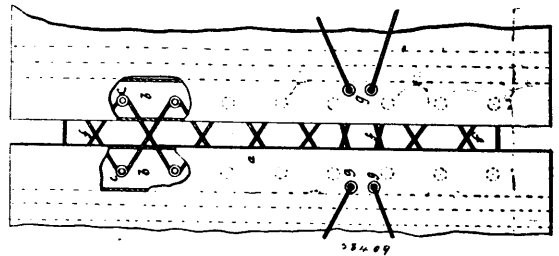
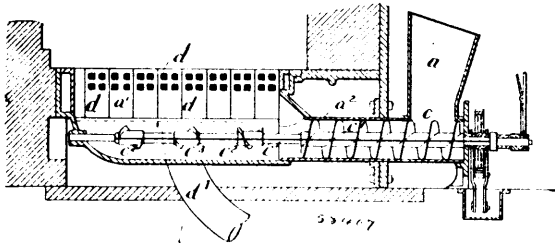

substantially as specified. 3rd. The combination of a fuel magazine having a curved bottom and tapered sides, a conduit leading horizontally from said magazine and consisting of a pipe whose axis also forms the axis of the curved portion of said magazine, said conduit being of a uniform diameter and cut away on one side near its outer end to form a fuel-opening, and a hopper above said fuel-opening, a screw conveyer extending through said conduit and the curved portion of said magazine, said conveyer being formed of a uniform carrying capacity through said conduit and adapted to fit the same, and of a reduced carrying capacity within the bottom portion of said magazine, substantially as specified. 4th. The combination with a fuel magazine having a curved bottom, and a conduit leading laterally therefrom, said conduit consisting of a pipe of uniform diameter whose axis corresponds with the axis of the curved portion of said magazine, a hopper connected with said conduit, and a screw conveyer extending from said hopper centrally through said conduit into said magazine, said conveyer being formed of a uniform diameter and pitch within said hopper and conduit, and being tapered to form a gradually reduced diameter within the magazine, substantially as specified. 5th. The combination with a magazine constructed of a substantially uniform width and having tapered sides and a concave bottom as described, a horizontal conduit leading from one end of said magazine, and a hopper arranged above said conduit so as to discharge therein, a square shaft extending centrally through said conduit and magazine, the bottom of said magazine forming a substantial continuation of said conduit, and conveyer flights on said shaft, said conveyer flights being formed to fit said conduit and having a uniform carrying capacity within the same and a reduced carrying capacity within the magazine, substantially as specified.

eyelets passing from side to side through the holes in the stiffeners and through the interposed flies, the ends of the eyelets being secured to the outer face of the stiffeners, and a grooved pulley journaled on the shank of each eyelet between the inner face of the flies, the latter being turned back so as to cover the exterior of the stiffeners and the ends of the eyelets, as and for the purpose set forth.

No. 58,410. Hot Water or Steam Heating System.
(Appareil de chauffage à eau ou vapeur.)

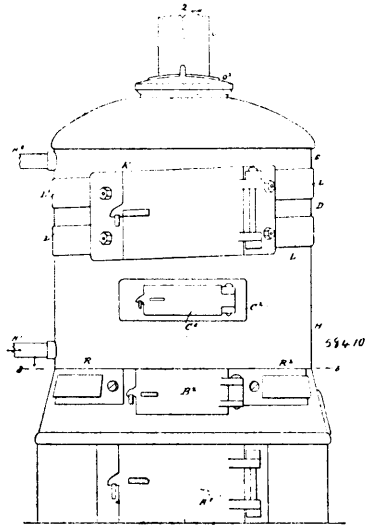

No. 58,408. Folding Table. (Table pliante.)

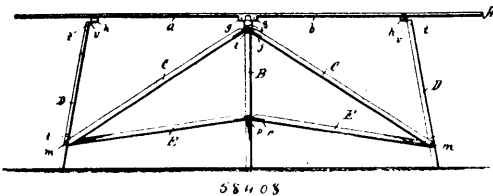

Clarence C. Longard, Halifax, Nova Scotia, Canada, 16th December, 1897; 6 years. (Filed 24th November, 1897.)

Onésime C. Beloin, East Providence, Rhode Island, U.S.A., 16th December, 1897; 6 years. (Filed 22nd November, 1897.)

Claim.—A sectional folding table divided into two boards *a* and *b* and having its top provided with legs *B B* and *D D*, said legs connected to the top-sections by hinges *ff* and *rr* as set forth, the central legs *B B* having a supporting cross-piece *y*, said legs provided with movable sleeves *ss*, with pins *ll*, with the stationary plated *nn* having fixed pins *pp*, said pins *ll* and *pp* carrying, respectively, the outer and inner braces *C C* and *E E*, said braces being provided with hinges *jj* and *rr* fastened thereon, the end legs *D D* having cross-pieces *tt* at top and bottom, with pins *mm* for connecting the ends of the outer and inner braces *C C* and *E E* and legs *D D* respectively, substantially as shown and described.

No. 58,409. Invisible Lacing. (Lacage invisible.)

Albert Romaine Colton, Rochester, New York, U.S.A., 16th December, 1897; 6 years. (Filed 24th November, 1897.)

Claim.—1st. In a corset, a lacing edge consisting of two separated flies, stiffeners on the outer faces of the same at some distance from their edges extending their entire length and provided with a series of registering holes, and eyelets passing from side to side through the holes in the stiffeners and through the interposed flies, the ends of the eyelets being secured to the outer face of the stiffeners and the flies being turned back so as to cover the exterior of the stiffeners and the ends of the eyelets, as and for the purpose set forth. 2nd. In a corset, a lacing edge consisting of two flies, stiffeners on the

Claim.—1st. A sectional hot water boiler with screw-shaped hollow sections containing water-ways, which all receive water from and discharge into a continuous uninterrupted vertical water-way with smoke passages and connecting pipes substantially as shown and described. 2nd. In sectional hot water boilers, the screw-shaped hollow section with the central opening for the magazine. 3rd. In sectional hot water boilers, the continuous and uninterrupted vertical water-way in connection with the screw-shaped water-ways substantially as shown and described. 4th. In sectional hot water boilers, the fire-pot section having the upper portion screw-shaped with an upward inclined surface, such upper portion containing a screw-shaped water-way terminating at and discharging into the lower extremity of a vertical water-way, and with an opening in the centre over which is placed the base of the magazine, substantially as shown and described. 5th. In sectional hot water boilers, a fuel magazine cylinder passing vertically through all the sections, but detached from them, and with an interval between it and the inner walls of the sections to admit a free passage of the products of combustion, thus heating the portion of all the sections immediately adjoining the magazine. 6th. In hot water boilers a fuel magazine with a movable under cover resting upon a shoulder on the cylinder and attached to an upper and external cover by a pin on which it plays freely, and with perforations in the side of the cylinder between such upper and lower covers, substantially as shown and described. 7th. In hot water boilers, a sectional boiler provided with removable plates for giving access to the smoke passages, substantially as shown and described. 8th. In a sectional hot water boiler with smoke passages between the sections, the mode of closing the passages at their margins by detachable segmental bands or plates, substantially as shown and described. 9th. In a hot water

sectional boiler with smoke passages between the sections, the mode of enclosing the passages by detachable segmental bands of plates secured by means of screw bolts passing through blocks slotted to engage upon pintels cast upon the surface of the sections, substantially as shown and described.

No. 58,411. Grates for Stoves and Furnaces.
(*Grille pour poêles et fournaies.*)

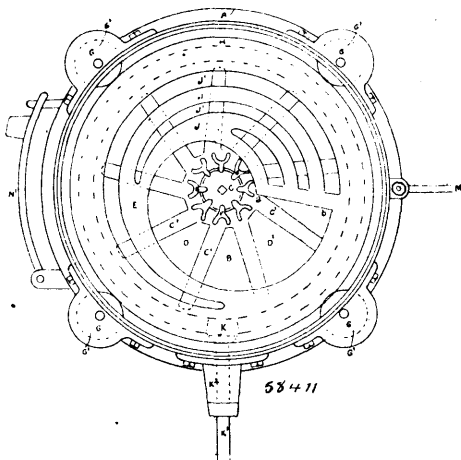

Clarence C. Longard, Halifax, Nova Scotia, Canada, 16th December 1897; 6 years. (Filed 24th November, 1897.)

Claim.—1st. In fire-grates, the combination of a fixed lower grate having a central opening and radiating passages with parallel sides and a movable centre-piece, on top of which is an upper revolving grate containing a cam-shaped opening, constructed and operated and for the purposes substantially as described. 2nd. In fire-grates, a fixed lower grate having a central opening, from which radiate passages the sides of which are parallel or gradually widen toward the central opening, constructed and for the purposes substantially as described. 3rd. In fire-grates, a revolving upper grate containing an opening of such a shape that the boundaries thereof form a cam thrusting inwards toward the centre, constructed and for the purposes substantially as described. 4th. In fire-grates having a fixed lower grate with a central opening and a revolving upper grate, a centre-piece with pivoted fingers attached to the head adapted to close the central opening, constructed and for the purpose substantially as shown and described.

No. 58,412. Gravity Sash Fastener.
(*Attache de châssis à gravité.*)

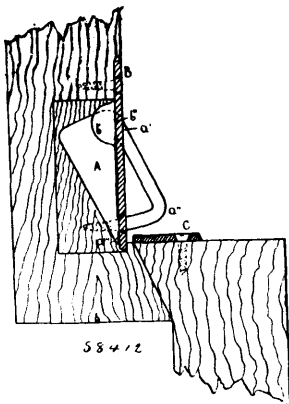

George Arthur Gordon, Pickering, Ontario, Canada, 16th December, 1897; 6 years. (Filed 27th November, 1897.)

Claim.—1st. The vertically suspended latch A, of rectangular or other suitable shape, loosely hung by its upper forward corner a^1 from a horizontal pin or rivet b^{11} on a vertically slotted guide-plate B, so that its lower forward corner a^{11} swings through the slot S and over the catch-plate C on the lower sash frame, the said latch A having a projection a^{111} on its back lower corner to prevent the latch from swinging too far forward, as hereinbefore described and illustrated in the drawing. 2nd. The vertically slotted guide-plate

B secured on the lower part of the upper sash-frame, over a suitable recess for the latch A to swing back into, said guide-plate having two lugs b^1 (one on each side of the upper part of the slot S) carrying a horizontal pin or rivet b^{11} from which the latch A swings, for the purpose as hereinbefore described and illustrated in the drawing. 3rd. The gravity sash fastener, consisting of a vertically swinging latch A loosely hung or suspended by its upward forward corner a^1 from a horizontal pin or rivet b^{11} on a slotted guide-plate B, which is secured on the lower part of the upper sash-frame, so that the forward lower corner a^{11} of the latch A swings forward through the slot S and rests just over a small catch-plate C on the lower sash-frame, a small projection a^{111} on the lower back corner of the latch preventing it from swinging too far forward, the whole combined and operating as and for the purpose set forth, as hereinbefore described and illustrated in the drawing hereunto annexed.

No. 58,413. Method of Applying Rubber Soles and Heels to Boot and Shoe Bottoms. (*Méthode d'assujettir les semelles de caoutchouc aux chaussures.*)

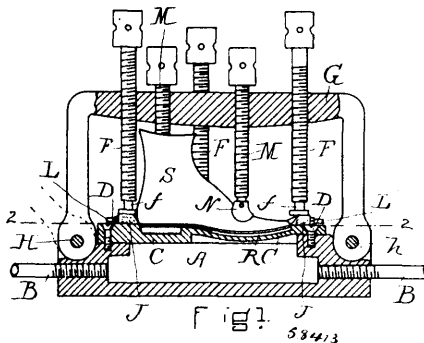

George Franklin Butterfield, Stoneham, Mass., U.S.A., 16th December, 1897; 6 years. (Filed 29th November, 1897.)

Claim.—1st. The steam-chamber A having an opening in its top, and provided with steam connections, in combination with the removable mould-plate C recessed to receive the rubber soling, and adapted to fit over and close said opening, and with suitable clamping means to secure said plate upon the chamber and the shoe upon the plate, over its recess, substantially as set forth. 2nd. The steam-chamber A open at the top and provided with steam connections, and the mould-plate C fitting over said opening, secured by screws D, and having a sole-shaped recess in its upper surface, in combination with a skeleton frame above said plate and the shoe held thereon, the laterally-adjustable plates J, J, and screws K, K, and with clamp-screws through said frame, serving to secure said plates and shoe in place, above the mould-plate, substantially as set forth. 3rd. The steam-chamber A open at its top, the removable mould-plate C having a sole-shaped recess in its upper surface and fitting marginally as a cover for said opening, and clamping means to hold said plate firmly in position, in combination with laterally-adjustable plates fitting along the in-seam of the shoe to confine it and the rubber, and with movable frame carrying pressure-screws for said plates and shoe, substantially as set forth. 4th. In a vulcanizing apparatus, a steam-chamber, a mould-plate having a rubber-containing mould in its outer face, in combination with a skeleton frame hinged to the chamber and provided with fastenings for securing a shoe over and upon the rubber enclosed in said mould, leaving the upper-leather of the shoe practically uncovered and exposed to the open air during vulcanizing of the rubber, whereby injury to the upper by heating is obviated, substantially as set forth. 5th. The described method of uniting vulcanized-rubber soles to the leather bottoms of boots and shoes, consisting in forming such sole in a mould and suitably vulcanizing it therein, then coating the upper surface of such sole with rubber-cement and applying thereon a sheet of unvulcanized rubber compound, then coating the shoe bottom with rubber-cement and holding the shoe pressed firmly upon said unvulcanized sheet, and finally vulcanizing such sheet while the shoe is so held, thereby firmly uniting said sole to the shoe, substantially as set forth.

No. 58,414. Churn Dasher. (*Cylindre de barattes.*)

Howard H. Sheely, Hutchinson, Kansas, U.S.A., 16th December, 1897; 6 years. (Filed 1st December, 1897.)

Claim.—In a churn-dasher, the combination with a reciprocating shaft, of a rotatable rectangular dasher-head or plunger of sufficient area to displace the liquid above and below the same in its reciprocation, vertically vibrating paddles or blades located upon the sides

supported from the casing, adjustable side plates on the bracket block, an induction passage, and an exhaust passage being formed in the bracket block, an adjustable gate in said induction passage, and an adjustable gate in the exhaust passage, as specified.

No. 58,418. Journal Bearing. (*Coussinet de tourillon.*)

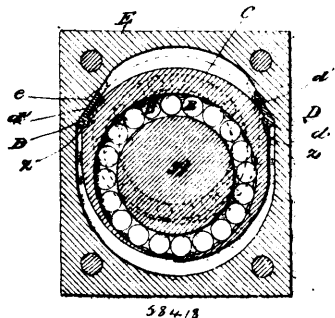

Charles H. Woodworth, Slater, Missouri, U.S.A., 16th December, 1897; 6 years. (Filed 26th November, 1897.)

Claim.—1st. The combination with a journal and a series of anti-friction devices surrounding it, of an open spring-ring encircling said anti-friction devices, said ring being of such diameter that when in use it has a constant tendency to contract, and means for transmitting the load to said rings at two points located upon opposite sides of the vertical diameter of the journal, substantially as set forth. 2nd. The combination with a journal and a series of anti-friction devices surrounding it, of an open spring-ring encircling said anti-friction devices, said ring being of such diameter that when in use it has a constant tendency to contract, and a pair of shoes for transmitting the load directly to said ring at two points located upon opposite sides of the vertical diameter of the journal, substantially as set forth. 3rd. The combination with a journal and a series of anti-friction devices surrounding it, of an open spring-ring encircling said anti-friction devices, a pair of movable shoes through which the load is transmitted to the ring, said shoes being in engagement with the ring upon opposite sides of its vertical diameter, and seats upon which said shoes bear and are adapted to slide in order to accommodate themselves to the position of the ring, substantially as set forth. 4th. The combination with a journal, of a series of anti-friction devices surrounding it, a ring encircling said anti-friction devices, a pair of movable shoes through which the load is transmitted to the ring, said shoes being in engagement with the ring upon opposite sides of its vertical diameter, and seats against which said shoes bear and upon which they are adapted to slide, said shoes having rocking engagement with the ring, substantially as set forth. 5th. The combination with a journal and a series of anti-friction devices surrounding it, of an open spring-ring having a constant tendency to contract, encircling said anti-friction devices, a pair of movable shoes having circular projections, and seats upon which said shoes bear and are movable, the ring being provided upon opposite sides of its vertical diameter with circular sockets in which the projections of the shoes fit, substantially as set forth. 6th. The combination with a journal and a series of anti-friction devices surrounding it, of an open spring-ring having a constant tendency to contract, encircling said anti-friction devices, a pair of movable shoes having circular projections, and seats upon which said shoes bear, the ring being provided with circular sockets in which the circular projections of the shoes fit and with shoulders engaging the ends of said projections, substantially as set forth. 7th. The combination with a journal and a plural series of anti-friction devices surrounding it, of a plurality of open spring-rings encircling said anti-friction devices, means for transmitting the load to each of the rings at two points located upon opposite sides of its vertical diameter, and means for holding said rings at the proper distance apart, substantially as set forth. 8th. The combination with a journal and a series of anti-friction balls surrounding it, of an open spring-ring having a constant tendency to contract encircling said balls, said ring being provided with overlapping ends, the inner one of which is bifurcated and provided along the inner edges of its two divisions with converging bearings for the balls, substantially as set forth. 9th. The combination with a journal and a bearing therefor, of a journal-box having opposite the end of the journal an annular race and an anti-friction ball arranged on said race, the point of contact between the race and ball being between the end of the journal and a vertical plane which is perpendicular to the axis of the journal and cuts the centre of the ball, whereby the ball is given a tendency to roll away from the end of the journal, substantially as set forth. 10th. The combination with a journal and a bearing therefor, of a journal-box having opposite the end of the journal an annular race, the outer wall of which, below the horizontal diameter of the journal, slopes downward and away from the end of the journal, and the inner wall of which, above the horizontal diameter of the journal, slopes downward and away from the end of the journal, and a ball arranged in said race, substantially as set forth.

No. 58,419. Grain Bundle Stacker.

(*Appareil pour ameulonner le grain.*)

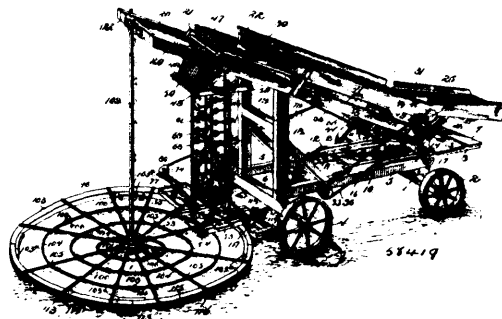

Henry F. Spaulding, Canastota, South Dakota, U.S.A., 16th December, 1897; 6 years. (Filed 30th October, 1897.)

Claim.—1st. A revoluble stack-forming base or platform, in combination with a stacker for depositing thereon bound bundles of grain in rows and courses in the formation of a stack, substantially as set forth. 2nd. A revoluble stacking-base, in combination with a stacker provided with an adjustable conveyer-section bearing a chute movable with the said conveyer-section and adapted to deposit the bound bundles of grain upon the revoluble stack-forming base when building the stack, substantially as specified. 3rd. A revoluble stacking-base, in combination with a stacker having an adjustable conveyer-section, provided with a chute capable of being lengthened and shortened and movable with the said conveyer-section so as to deposit the bundles of grain upon the stacking-base in the formation of the stack, substantially as specified. 4th. In a stacking-machine, the combination with a conveyer, comprising a relatively-fixed and a movable section, of a chute carried by the movable section, a drum operatively connected with the movable section for extending it, a second drum for lengthening and shortening the chute, a clutch mechanism for connecting the two drums, whereby the movable section and chute can be simultaneously actuated and the delivery end of the chute caused to maintain a position in a given plane, and the chute be independently operated so as to be lengthened and shortened, substantially as set forth. 5th. The combination with a stacker, of a chute comprising a guide formed by vertical supports composed of links having pivotal connection and arranged to yield outwardly at their upper ends and to resist outward pressure between their ends and to maintain a normal vertical position, substantially as set forth. 6th. The combination with a stacker, of a chute comprising vertical supports composed of links, having interlocking pivotal joints formed by an approximately butterfly projection on the end of one link and a corresponding slot on the end of the adjacent link to receive the wings of the butterfly projection, substantially in the manner and for the purpose set forth. 7th. In a stacker, the combination of a chute comprising vertical supports, and toothed wheels at intervals in the length of the supports, substantially as set forth and for the purpose described. 8th. In a stacker, the combination with a hopper, and guards exterior thereto, of a guide comprising vertical supports, formed of links pivotally connected together and adapted to have their ends abut, whereby the links are held in alignment against pressure from within the guide and the upper links capable of yielding by engagement with the said guards, substantially as set forth for the purpose described. 9th. In a stacker, a chute comprising a hopper, bars adjustably connected together and supporting the sides of the hopper, guards exterior to the hopper, vertical supports composed of pivoted links capable of resisting pressure against their inner sides, lower bars adjustably connected together and having the said supports connected therewith, toothed wheels at intervals in the length of the supports, and means for raising and lowering the lower bars, whereby the chute can be lengthened or shortened, substantially as set forth for the purpose described. 10th. In a stacker, the combination of an adjustable platform, a pivoted conveyer-section, and actuating mechanism for simultaneously moving both the platform and the said pivoted conveyer-section, substantially as and for the purpose set forth. 11th. In a stacker, the combination of a platform having rearwardly extending arms provided with teeth, a pivoted conveyer-section, a bar having connection with the pivoted conveyer-section and formed with teeth, and a shaft provided with pinions meshing with the arms of the platform and with the teeth of the said bar, whereby both the platform and the conveyer-section are capable of simultaneous adjustment, substantially as set forth. 12th. In a stacker, the combination with a chute comprising parallel bars adjustably connected together and notched to form a guide, and a frame attached to one of the bars, of a fork operating across the space between the bars and moving in the said notches, a spring mounted upon the stem of the fork between the bar and the frame, and a rope or cord under the control of an attendant, whereby the said fork can be actuated, substantially as set forth for the purpose described. 13th. A revoluble stacking base comprising a hub, an

tom of the chamber, said plate having an opening at the bottom of the chamber through which the contents of the latter is discharged,

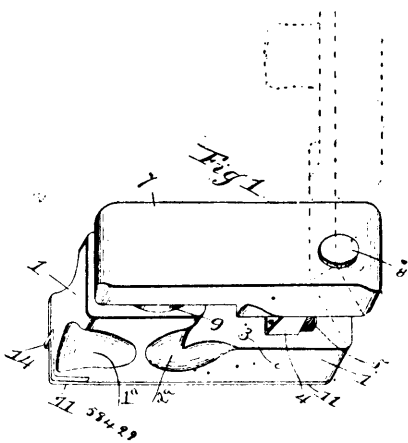

as set forth. 5th. A pointing implement having a chamber in one end, and a spring-controlled lever pivoted at the other end carrying a plunger adapted to engage the chamber, a surface plate covering the bottom of the implement and provided with apertures, a clearing blade in line with and forward of the discharge opening, a roller revolvably secured in the body of the implement in line with and in the rear of said opening, a scraping knife set at an angle across the line of said blade and roller and in the rear of the latter, said clearing blade, roller, and scraping knife projecting through the plate apertures, as set forth. 6th. A pointing implement having a chamber, a lever carrying a plunger, a plate covering the bottom of the implement and having a discharge opening at the bottom of the chamber, a clearing blade forward of and in longitudinal line with said opening, a roller and a scraping knife in rear of and at an angle to the blade across such line, said blade and knife being secured to the bottom of the implement by said plate and projecting through the latter, substantially as set forth. 7th. A pointing tool having a chamber, a plate covering the bottom of the chamber, and having a discharge opening in said bottom, a hand lever connected by a spring to the end of the tool opposite the chamber to form a hinge and pivot for the lever, a clearing-blade secured to the bottom of the tool in line with said discharge opening, a roller in the rear of and in line with the blade, and scraping knife in the rear of the roller and across such line, said blade, roller and knife projecting through said plate apertures, substantially as set forth. 8th. In a pointing implement, the combination of the body having a chamber in one end, a hand lever having a plunger, a spring pivotally connecting the lever to the other end of the body, a covering for the bottom of the chamber having a discharge opening, a clearing blade, a roller and a scraping knife secured to the bottom of the implement, as set forth. 9th. In a pointing implement, the body having a chamber at one end, a spring housing therefor secured to the other end, a hand lever having a plunger, and pivoted to the spring so as to be turned at right angles to the tool body combined with the bottom plate for the chamber having a discharge opening, a cutter forward of said opening, a scraping knife in the rear of said opening, and a roller between the opening and the scraping knife, said roller being journaled in the body of the tool and projecting beyond its bottom surface, and the said clearing blade and scraper being secured in cavities in the bottom of the tool and also projecting beyond its surface, as set forth. 10th. A pointing tool having a chamber in one end, a discharge opening in the bottom of the chamber, a clearing blade projecting below, forward of and contiguous to said discharge opening, and a hand lever carrying a plunger and hinged to the end of the body opposite the chamber, as set forth.

No. 58,423. Process of and Apparatus for Treating Garbage, etc. (Procédé et appareil pour le traitement des trippailles, etc.)

The Detroit Liquid Separating Company, Detroit, assignee of Stephen E. Wilson, French Landing, both in Michigan, U.S.A., 17th December, 1897; 6 years. (Filed 28th July, 1897.)

Claim.—1st. The method of expressing liquids from a mass or charge of material which consists in applying fluid-pressure to all parts of its surface simultaneously. 2nd. The method of expressing liquids from a mass or charge of material, which consists in dividing said mass into a number of comparatively small bodies and applying fluid under pressure to all the surfaces of the divided bodies. 3rd. The method of expressing liquids from a mass or charge of material, which consists in dividing the mass or charge by a series of perforate bodies and applying fluid under pressure

to all the surfaces of the divided mass through said perforated bodies. 4th. The method of expressing liquids from a mass or

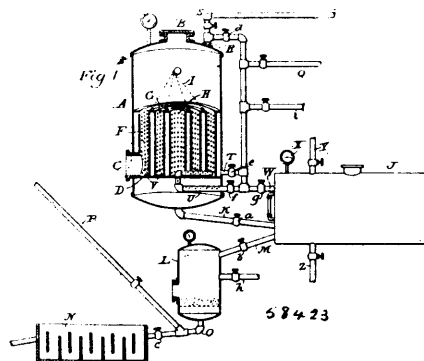

charge of material, which consists in cooking the mass and then applying fluid pressure to all parts of its surface simultaneously. 5th. The method of expressing liquids from a mass or charge of material, which consists in first dividing the mass into a number of comparatively small bodies, cooking the same, and finally applying fluid under pressure to different faces or surfaces of the mass simultaneously. 6th. The method of expressing liquids from a mass or charge of material, which consists in first dividing the material into a number of comparatively small bodies, applying fluid under pressure to different faces or surfaces of the mass simultaneously, and finally collecting the resultant liquids in a tank in which pressure is maintained. 7th. The method of treating garbage and like material, which consists in sustaining the mass in a perforate surface, cooking the same, applying fluid under pressure simultaneously to different faces or surfaces of the mass, collecting the resultant liquids, and separating the grease from the liquid. 8th. A rendering-tank, comprising the shell or body, provided at its upper end with a charging-opening, a perforate false bottom or grid, an opening C in line with said grid, one or more perforate draining-chambers resting upon the false bottom, and means for elevating said chambers.

No. 58,424. Apparatus for Drying Wheat, Brewer's Grains, etc. (Appareil pour sécher le grain pour les brasseries.)

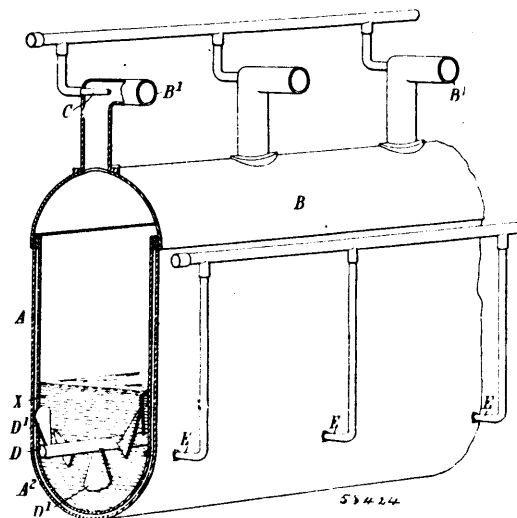

The Fish Oils Guano Syndicate, Limited, Dublin, Ireland, assignee of John William Stanley, London, England, 17th December, 1897; 6 years. (Filed 14th July, 1897.)

Claim.—1st. In a drier the combination with a long narrow vessel having a rounded bottom, of a worm or stirrer D lying lengthwise along that bottom, for the purpose set forth. 2nd. In a drier of the kind described a perforated shaft or worm, or nozzles or jets for delivering air into the mass of material under treatment in the apparatus substantially as set forth. 3rd. In a drier the combination with a long narrow vessel having a rounded bottom, of a worm or stirrer D lying lengthwise along that bottom, and nozzles for delivering air into the material under treatment, substantially as set forth. 4th. In a drier of the kind described, the combination of an exit pipe B¹, and an ejector C, for the purpose set forth. 5th. Two

or more driers of the kind described so combined as to enable the material therein to be continuously circulated, substantially as set forth. 6th. In a drier of the kind described, the combination with a long narrow vessel A, having a rounded bottom, of a worm or stirrer D, with vanes D¹, nozzles or jets E, exit pipes B¹, and ejectors C, substantially as set forth.

No. 58,425. Gas Generator. (Générateur à gaz.)

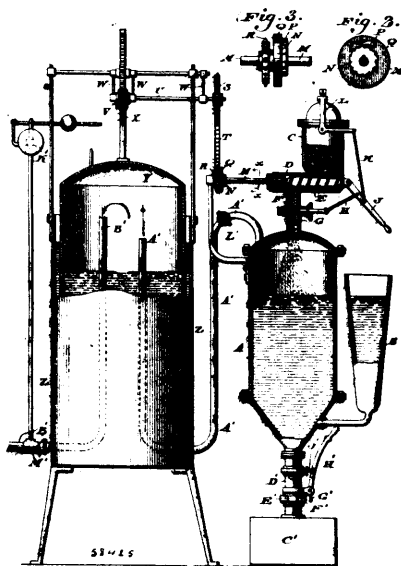

Edmund Reamer Bulkley, (trustee), assignee of Charles Henderson Campbell, both of Philadelphia, Pennsylvania, U.S.A., 17th December, 1897; 6 years. (Filed 10th May, 1897.)

Claim.—1st. In an acetylene gas generator, a material-containing chamber, and a water-containing vessel, in combination with a conveyer interposed between said chamber and vessel and adapted to be operated in one direction only and feed the material to the water. 2nd. The combination of a generator, a chamber for containing gas-forming material, a feed trough at the bottom of said chamber, a conveyer in said trough, said trough being in communication with said generator, a ratchet-wheel connected with the shaft of said conveyer, a pawl carried loosely on said shaft, a gas holder and means intermediate of the same and said pawl, whereby the latter is operated, and motion imparted to the conveyer. 3rd. In a gas apparatus, a conveyer intermediate of the supply chamber and the generator, and a gas holder in combination with a rack attached to said holder, a pinion meshing with said rack, and means operated by said rack for imparting rotation to said conveyer in only one direction, whereby the feeding of said material to the generator is accomplished as the resultant gas is discharged from the holder. 4th. A gas generator, a supply chamber, a feeding conveyer intermediate of said chamber and generator, and a gas holder in combination with a rack attached to said gas holder, a pinion meshing therewith, and connections for the shaft of said pinion and said conveyer, including a pawl and ratchet, whereby said conveyer receives motion in only one direction. 5th. In a gas generator, a conveyer intermediate of the supply chamber, and a generator in combination with a ratchet fixed to the shaft of said conveyer, a pawl carried loosely on said shaft, and gearing intermediate of said pawl and a gas holder, whereby motions in opposite directions are imparted to said pawl, so that on the ascent of said gas holder the supply of material to said generator ceases, and on the descent of the same the generator receives a supply of said material. 6th. In a gas generator, a supply chamber, a feeding device therefor, a gas generator, and a communication between said chamber and generator, in combination with a valve in said communication, and a cover for said holder, and means whereby when said holder is opened said valve will be closed, and *vice versa*. 7th. In a gas generator, a sediment chamber or box removably connected with said generator, a sectional pipe intermediate of the same, and a coupling for the sections having a recess therein, and a valve between said generator and chamber, in combination with a lever which is adapted to operate said valve and to interlock with said union when the valve is opened, and to be disconnected from said coupling when the valve is closed. 8th. In an acetylene gas generator, a material-containing chamber, a water containing vessel, a conveyer between said chamber and vessel for feeding the material to the water, a gas tank and holder, means on said holder for operating said conveyer in one direction, a pipe leading from said vessel into said holder, a pipe leading from said holder to the place of service, and a safety valve connected with either or both of said pipes.

No. 58,426. Process for Electrizing Water for Heating Purposes. (Procédé pour électriser l'eau pour système de chauffage.)

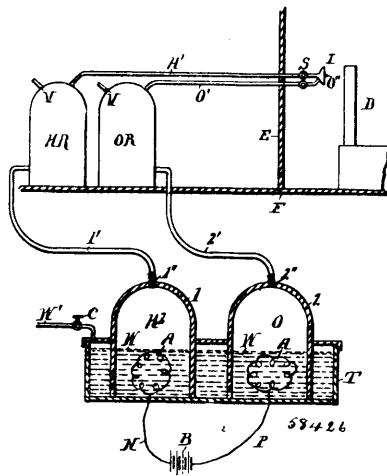

Dr. Thomas Henderson, Detroit, assignee of Philippe Huber, Saginaw, both in Michigan, U.S.A., 17th December, 1897; 6 years. (Filed 29th March, 1897.)

Claim.—In a heating system, the combination with an apparatus for the manufacture of hydroge and oxygen gases from water by the electrization thereof, and for separating the gases and storing them, of tubes conveying the gases in separate pipes to a burner, the tube conveying the oxygen gas passing through the face of the burner at the middle thereof and terminating just in front of the burner, and the tube conveying the hydrogen gas having the burner formed upon the end thereof, the burner being circular in form and provided with small holes on its front face through which the hydrogen passes, and means in front of the burner for receiving and radiating the heat, and means as described for regulating the supply of gas to the burner, substantially as and for the purposes set forth.

No. 58,427. Process of Separating Nickel from Copper Ore and Matte. (Procédé pour séparer le nickel de la matte de cuivre.)

Noak Victor Hybinette, Brooklyn, and Albert R. Ledoux, New York, both in the State of New York, U.S.A., 17th December, 1897; 6 years. (Filed 10th October, 1896.)

Claim.—1st. The process of separating copper from nickel in their sulphur compounds, consisting in fusing the mixed sulphides, treating the fused mass with sulphide of manganese and thereby effecting solution of the copper sulphide in said manganese sulphide, allowing the nickel sulphide to subside and removing the supernatant sulphides of manganese and copper. 2nd. The process of separating copper from nickel in their sulphur compounds, consisting in fusing the mixed sulphides, treating the fused mass with sulphide of manganese and an alkali sulphide and thereby effecting solution of the copper sulphide in said manganese sulphide, allowing the nickel sulphide to subside and removing the supernatant sulphides of manganese and copper. 3rd. The process of separating copper from nickel in their sulphur compounds, consisting in fusing the mixed sulphides, treating the fused mass with sulphides of manganese produced by mixing the raw materials therefor with the ore or matte and thereby effecting solution of the copper sulphide in said manganese sulphide, allowing the nickel sulphide to subside and removing the supernatant sulphide of manganese and copper. 4th. The process of separating copper from nickel in their sulphur compounds, consisting in fusing the mixed sulphides, treating the fused mass with sulphide of manganese and sulphide of alkali produced by mixed the raw materials therefor with the ore or matte and thereby effecting solution of the copper sulphide in said manganese sulphide, allowing the nickel sulphide to subside and removing the supernatant sulphide of manganese and copper.

No. 58,428. Saw Set. (Fer à contourner.)

John Bowles, Washington, Columbia, and Cornelius Smith Mitchell, New York, State of New York, U.S.A., 17th December, 1897; 6 years. (Filed 8th November, 1897.)

Claim.—1st. In a saw set, the combination with a female die having a transverse groove formed with an inclined side, and a bottom parallel with the face of the die on which the saw is supported, of a male die having an inclined face to fit the corresponding side of the female die groove and a groove L adjacent to the inclined face, substantially as described. 2nd. In a saw set, the combination with a female die having a transverse groove formed with an inclined side and a bottom parallel with the face of the die on which the saw

is supported, of a male die having an inclined face to fit the corresponding side of the female die groove, and a groove L adjacent to

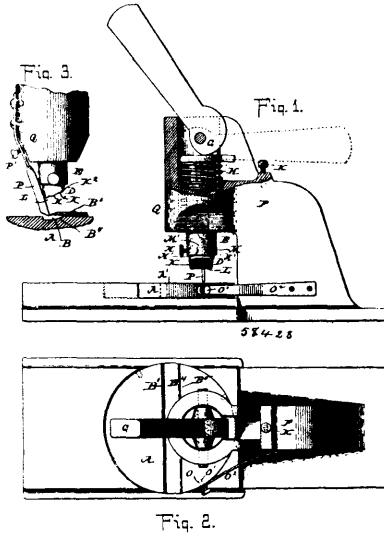

said inclined face, and a stop to bring the edge of the saw tooth in line with said groove L, substantially as described. 3rd. The combination with the frame of the saw set, and the female die pivoted thereon, having a plurality of radiating grooves with inclined sides, and formed with corresponding bolt-holes of the male die having an inclined groove to engage either of said female die grooves, and a pin to engage either of said bolt-holes and secure the corresponding female die groove in register with the male die groove. 4th. The combination with the female die formed with a plurality of grooves having their sides inclined in opposite directions, of a male die holder, a male die having an inclined face to engage either of said female die grooves and means for reversing and locking said male die in the die holder to suit either of the oppositely inclined female die grooves. 5th. In a saw set, a male die having a depending finger provided with a bevelled side adapted to come in contact with the edge of the saw tooth when the die descends, and operate to force the saw tooth into proper position to be acted upon by the face of the die, substantially as described. 6th. In a saw set, a pair of dies having inclined faces to bend the saw tooth away from the plane of the saw, and other faces adapted to bend back the edge of the saw tooth to a position parallel with said plane, substantially as described. 7th. The method of setting a saw which consists in bending the body of the saw tooth at an angle with the plane of the saw, and bending back the extreme edge of the tooth to a position parallel with said plane, substantially as described. 8th. The method of setting a saw which consists in bending the cutting edge of the saw tooth at an angle with the plane of the saw.

No. 58,429. Tire-Setting Machine.
(Machine à poser les bandages.)

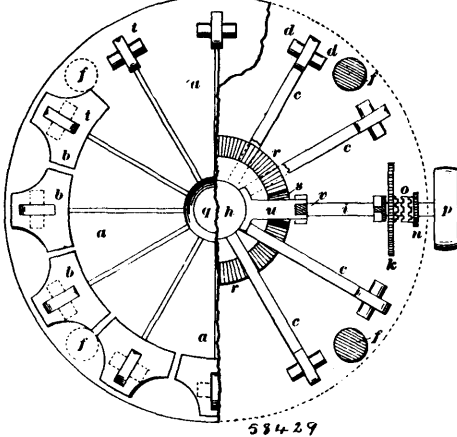

Phillippe D. Dupont and Joseph Gauthier, both of St. Johnsbury, Vermont, U.S.A., 17th December, 1897; 6 years. (Filed 25th October, 1897.)

Claim.—1st. The combination in a tire setting machine, of a series of blocks forming a complete circle and operated by a corresponding number of bell-crank levers all fulcrumed in a common plate, connected at their ends to a nut working on a central screw, substan-

tially as set forth. 2nd. The combination in a tire-setting machine, of a solid top plate having on its upper surface a series of sliding pressure blocks, connected with the outer ends of a series of bell-crank levers, fulcrumed near the outer edge of the top plate, and connected at their inner ends by links to a nut on a central screw which is actuated by a train of gears, substantially as described. 3rd. The combination in a tire-setting machine, a series of pressure blocks connected by bell-crank levers and links to a nut working on a central screw, which is actuated by a train of gears so arranged as to make the speed interchangeable at the will of the operator, substantially as set forth and for the purpose described.

No. 58,430. Salt-Holder or Receptacle. (Salière.)

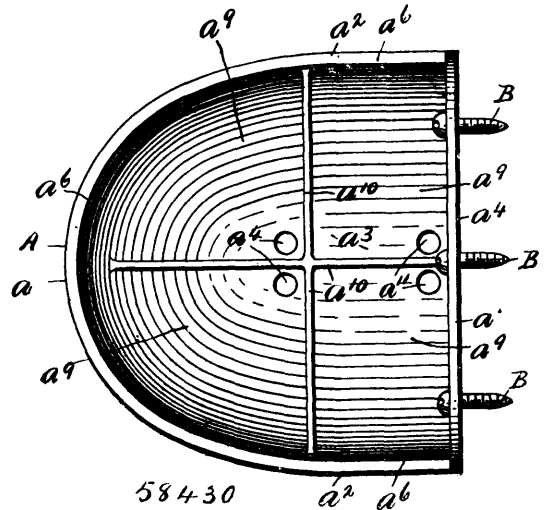

John Hampden Hopkins, (trustee), assignee of Hampden Hyde and Calvin Augustus Leonard, all of Rochester, New York, U.S.A., 17th December, 1897; 6 years. (Filed 20th May, 1897.)

Claim.—1st. As a new article of manufacture, the herein described salt-holder or receptacle, the same consisting of an enclosing shell A, provided with intersecting partitions or inner walls $a^1, a^2, a^3, a^4, a^5, a^6$, substantially as and for the purpose hereinbefore set forth. 2nd. As a new article of manufacture, the herein described salt-holder or receptacle, the same consisting of an enclosing shell A, formed with apertures a^7 , having contracted branches or slots a^8 , and fastening screws B normally arranged in the contracted branches or slots and provided with heads b , substantially as and for the purpose hereinbefore described. 3rd. As a new article of manufacture, the herein described salt holder or receptacle, the same consisting of an enclosing shell A, provided with a base or bottom wall a^9 , inclining upwardly from its rear portion and inclining upwardly in opposite directions towards the side walls a^2, a^2 , of the shell, said salt-holder or receptacle being provided with compartments a^0 and apertures a^1 , extending from substantially the lowermost portions of the compartments, substantially as and for the purpose hereinbefore specified.

No. 58,431. Electrolytic Apparatus.
(Appareil électrolytique.)

The Balbach Smelting and Refining Company, assignee of Edward Balbach, jr., both of Newark, New Jersey, U.S.A., 17th December, 1897; 6 years. (Filed 23rd August, 1897.)

Claim.—1st. The combination of a cathode case, composed of a trough having its bottom divided into two portions, one of which is horizontal, and the other of which is inclined, so as to slope down to and connect with the horizontal portion, throughout its length, and provided with a cathode plate, and an anode suspended therein, arranged to cover the horizontal portion of the bottom only. 2nd. The combination of a cathode case, composed of a trough having its bottom divided into two portions, one of which is horizontal, and the other of which is inclined, so as to slope down to and connect with the horizontal portion throughout its length, and lined throughout with a suitable material whereby the whole inner surface thereof serves as a cathode, and an anode suspended therein, arranged to cover the horizontal portion of the bottom only. 3rd. The combination of a cathode case composed of a trough having its bottom divided into two portions, one of which is horizontal, and the other of which is inclined, so as to slope down to and connect with the horizontal portion throughout its length, and provided with a cathode plate, and an anode case composed of an exterior frame having a grated bottom and provided with an inner frame with a filter cloth bottom, fitting into the exterior case, arranged to cover the horizontal portion of the cathode case only. 4th. The combination of a cathode case, composed of a trough having its bottom

divided into two portions, one of which is horizontal, and the other of which is inclined, so as to slope down to and connect with the

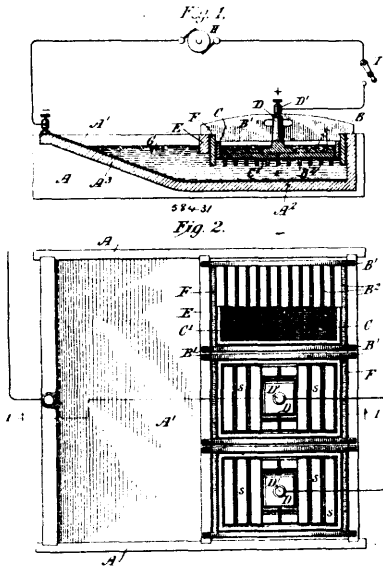

horizontal portion throughout its length, a cathode upon said bottom, and a series of removable anode cases arranged transversely side by side, to cover the horizontal portion of the cathode case only. 5th. The combination of a cathode case, composed of a trough having its bottom divided into two portions, one of which is horizontal, and the other of which is inclined, so as to slope down to and connect with the horizontal portion throughout its length, a cathode upon said bottom, and a series of removable anode cases arranged transversely side by side, each composed of an exterior frame having a grated bottom and provided with an inner frame with a filter cloth bottom fitting into the exterior case, arranged to cover the horizontal portion of the cathode case only.

No. 58,432. Fare-Box. (Boite à billets.)

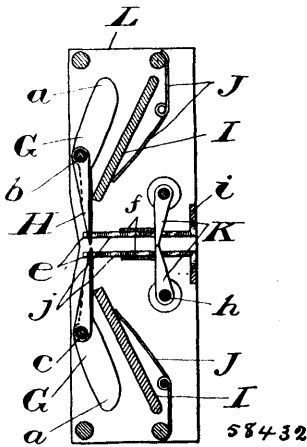

Joseph Henry Coleman, Tottenham, Ontario, and James Steel, Montreal, Quebec, both in Canada, 17th December, 1897; 6 years. (Filed 27th September, 1897.)

Claim.—1st. A fare-box having a passage-way for fares, in combination with one or more pivoted needles having their points normally out of the path of fares placed in the box, a pivoted lock-plate, and a spring adapted to counterbalance the weight of the lock-plate so that the plate will press the points of the needles into the passage-way for fares when the box is turned from its normal position, substantially as and for the purpose specified. 2nd. A fare-box having a passage-way for fares, in combination with two series of pivoted needles located one on each side of the passage-way with the needle-points normally out of the path of the fares placed in the box, a pivoted lock-plate for each series of needles, and a spring adapted to counterbalance the weight of each lock-plate so that the plate will press the points of the needles into the passage-way for fares when the box is turned from its normal position, substantially as and for the purpose specified. 3rd. A fare-box having a passage-way for fares, in combination with one or more

needles with weighted tails, adapted to normally retain the points of the needles in the path of fares placed in the box, a pivoted lock-plate, and a spring adapted to counterbalance the weight of the lock-plate so that the plate will maintain the points of the needles in their usual place when the box is turned from its normal position, substantially as and for the purpose specified. 4th. A fare-box having a passage-way for fares, in combination with two series of pivoted needles located one on each side of the passage-way and provided with weighted tails adapted to normally retain the points of the needles in the path of fares placed in the box, a pivoted lock-plate for each series of needles, and a spring adapted to counterbalance the weight of each lock-plate so that the plates will maintain the points of the needles in their usual place when the box is turned from its normal position, substantially as and for the purpose specified. 5th. A fare-box having a passage-way for fares, in combination with one or more pivoted needles having their points normally out of the path of fares placed in the box, one or more pivoted needles with weighted tails adapted to normally retain the points of the needles in the path of fares placed in the box, a pivoted lock-plate, and a spring adapted to counterbalance the weight of the lock-plate, substantially as and for the purpose specified. 6th. A fare-box having a passage-way for fares, in combination with one or more pivoted needles having their points normally out of the path of fares placed in the box, one or more pivoted needles with weighted tails adapted to normally retain the points of the needles in the path of fares placed in the box, one or more pivoted needles so placed that they will close the passage-way for fares and prevent the fares in the box from reaching the before-mentioned needles when the box is inverted, a pivoted lock-plate, and a spring adapted to counterbalance the weight of the lock-plate, substantially as and for the purpose specified. 7th. A fare-box having a passage-way for fares, in combination with two series of pivoted needles located one on each side of the passage-way, with the needle points normally out of the path of the fares placed in the box, two series of pivoted needles with weighted tails adapted to normally retain the points of the needles in the path of fares placed in the box, two series of pivoted needles located one on each side of the passage-way with the needle points normally out of the path of fares placed in the box, a pivoted lock-plate for each double series of needles, and a spring adapted to counterbalance the weight of each lock-plate, substantially as and for the purpose specified. 8th. In a fare-box, a passage-way for fares, in combination with the needles G, pivoted on the needles b, and provided with the weighted tails a, the needles H, similarly pivoted, the pivoted lock-plates I, the springs J, the bars e and f, and the vertical bars j, forming slots for the needle points, substantially as and for the purpose specified. 9th. In a fare-box, a passage-way for fares, in combination with the needles H, suitably journaled upon the spindles b, the pivoted lock-plates I, the springs J, the bars e and f, and the vertical bars j, forming slots for the needle points, substantially as and for the purpose specified. 10th. In a fare-box, a passage-way for fares, in combination with the needles H, suitably journaled upon the spindles b, the pivoted lock-plates I, the springs J, the bars e and f, the vertical bars j forming slots for the needle points, and the needles K and bars i, substantially as and for the purpose specified.

No. 58,433. Flower Pot and Transplanter.

(Pot à fleurs et transplantoir.)

FIGURE 1.

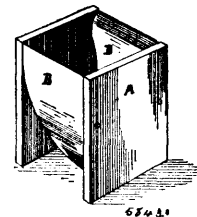
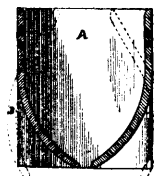

FIGURE 2.



Charles Sherman and Robert S. Eakins, both of Yarmouth, Nova Scotia, Canada, 17th December, 1897; 6 years. (Filed 29th September, 1897.)

Claim.—The combination of the stationary sides, the movable sides and pivots or screws to form a flower pot or transplanter as

illustrated in the drawings hereto annexed, substantially as and for the purposes hereinbefore set forth.

No. 58,434. Riveting Machine. (*Machine à river.*)

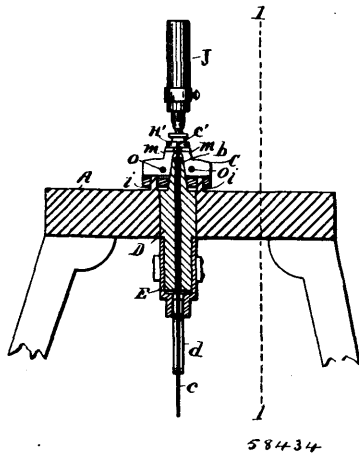

Orson W. Davis, Jonathan B. Davis and Thomas Gimbert, all of Adrian, Michigan, U.S.A., 17th December, 1897; 6 years. (Filed 30th September, 1897.)

Claim.—1st. In a riveting machine, the combination with the wire feeding mechanism, of the movable cutting and swaging dies between which the wire is fed, the reciprocal plunger moving in line with said dies, and onto the upper end of the rivet and at the same time actuating said dies to sever the wire and form a swage for heading over the rivet on the underside by the impact of the plunger which also forms a head upon the upper side of the rivet. 2nd. In a riveting machine, the combination with the cutting and swaging dies, of the pivoted jaws between which the wire is fed, the movable sleeve carrying said jaws, and the springs attached to the arms of said jaws and to a fixed support, a movable bar attached to said sleeve, a reciprocal plunger adapted to engage said bar whereby the feeding jaws are actuated to intermittently feed the wire in proper lengths to form each successive rivet. 3rd. In a riveting machine, the combination of the pivoted cutting and swaging dies mounted in a movable head, a reciprocal plunger carrying a heading swage which operates in line with said dies, the actuated feeding jaws engaging the wire which is fed between said dies, the connection between said jaws and the reciprocal plunger whereby by an operation of said plunger the rivet is cut and headed on both sides and the wire is fed through said dies a sufficient length to form the successive rivet. 4th. In a riveting machine, the combination of the pivotally mounted cutting and swaging dies between which the wire to form the rivet is fed, said dies being mounted to meet at their cutting points and having a registering concavity in their upper face, the movable head in which said dies are mounted, the step mounted on a fixed support and engaging the heel of said dies, the movable plunger carrying a heading swage mounted in line with said dies whereby by an operation of said plunger the wire is severed and the rivet headed on each side of the work. 5th. In a riveting machine, the combination with the cutting and swaging dies, the reciprocal plunger in line therewith, the feeding jaws mounted in a reciprocal sleeve, the springs attached to the arms of said jaws and to a fixed support, the reciprocal bar attached to said sleeve, the adjustable set screw carried by said bar projecting into the path of said plunger.

No. 58,435. Means for Closing Bulkhead Doors, etc. (*Système de fermeture pour les portes de cloisons étanches dans les navires.*)

William Barnum Cowles, Cleveland, Ohio, U.S.A., 17th December, 1897; 6 years. (Filed 15th November, 1897.)

Claim.—1st. In a hydraulic system of the character described, the combination with a ram cylinder adapted to contain a body of fluid under pressure, and a steam cylinder for exerting pressure upon said fluid, with valves for regulating the said pressure, of an emergency cylinder, with piston therein, and emergency mechanism operated by said piston, pipes respectively connected to each end of said cylinder and adapted to contain fluid under pressure, a fluid pressure pipe and an exhaust pipe, and a six-way valve for connecting the pipe from one end of said cylinder to the fluid pressure pipe and from the other end of the cylinder to the exhaust pipe, or *vice versa*, substantially as described. 2nd. In a hydraulic system of the character described, the combination with a ram cylinder adapted to contain a body of fluid under pressure, and a steam cylinder for exerting pressure upon said fluid, with valves for regulating the said pressure, of an emergency cylinder, with piston therein, pipes respectively connected to each end of said cylinder and adapted to contain fluid under pressure, a fluid pressure pipe

and an exhaust pipe, and means for connecting the pipe from one end of said cylinder to the fluid pressure pipe, and from the other end

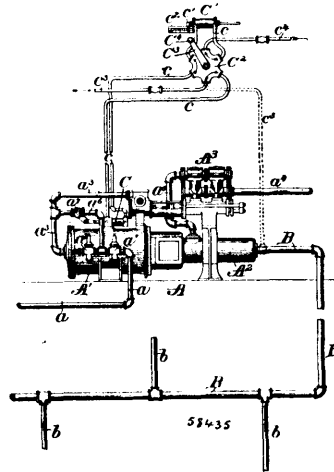

of the cylinder to the exhaust pipe, or *vice versa*, a fluid pressure main leading from the ram cylinder, branch pipes leading from said main, mechanism operated by the fluid in said branch pipes and mechanism operated by the piston in the emergency cylinder for regulating the pressure in the steam cylinder and so controlling the pressure in all of said branch pipes, substantially as described. 3rd. In a hydraulic system of the character described, the combination with a ram cylinder adapted to contain a body of fluid under pressure, and a steam cylinder for exerting pressure upon said fluid, with valves for regulating the said pressure, of an emergency cylinder, with piston therein, pipes respectively connected to each end of said cylinder and adapted to contain fluid under pressure, a fluid pressure pipe and an exhaust pipe, and means for connecting the pipe from one end of said cylinder to the fluid pressure pipe and from the other end of the cylinder to the exhaust pipe, or *vice versa*, a fluid pressure main connected to said ram cylinder, branch pipes leading from said main, door opening and closing mechanism operated by the fluid in said branch pipes and mechanism operated by the piston in the emergency cylinder and controlling the pressure in all of said branch pipes, and a hand-operated releasing valve connected to each of said branch pipes and adapted to control the flow of fluid through said branch pipe and to control the door opening and closing mechanism operated thereby, substantially as described. 4th. In a hydraulic system of the character described, the combination with a source of fluid pressure, of an accumulator adapted to contain fluid under pressure and itself operated by fluid from the source of fluid pressure, means for regulating the pressure of the fluid in the accumulator, a fluid pressure main leading from the accumulator, a branch pipe from said main, mechanism operated by the fluid in said branch pipe and a releasing valve located in said branch pipe and operated by hand at low pressures and automatically operated at high pressures, substantially as described. 5th. In a hydraulic system of the character described, the combination with a source of fluid pressure, of an accumulator adapted to contain a body of fluid under pressure, a plurality of reducing valves for regulating the admission of fluid pressure from said source to said accumulator, a by-pass opening from between said reducing valves into said accumulator, a valve controlling said by-pass, means for operating said valve, a fluid pressure main connected to said accumulator, branch pipes connected to said main, and mechanism operated by the fluid pressure in said branch pipes, substantially as described. 6th. In a hydraulic system of the character described, the combination with a source of fluid pressure, of an accumulator adapted to contain a body of fluid under pressure, a plurality of reducing valves for regulating the admission of fluid pressure from said source of said accumulator, a by-pass opening from between said reducing valves into said accumulator, a valve controlling said by-pass, means for operating said valve, a fluid pressure main connected to said accumulator, branch pipes connected to said main, and door opening and closing mechanism operated by the fluid pressure in said branch pipes, substantially as described. 7th. In a hydraulic system of the character described, the combination with a source of fluid pressure, of an accumulator adapted to contain a body of fluid under pressure, a plurality of reducing valves for regulating the admission of fluid pressure from said source to said accumulator, a by-pass opening from between said reducing valves into said accumulator, a valve controlling said by-pass, means for operating said valve, a fluid pressure main connected to said accumulator, branch pipes connected to said main, and a hand-operated releasing valve in each of said branch pipes, substantially as described. 8th. In a hydraulic system of the character described, the combination with a source of fluid pressure, of an accumulator adapted to contain fluid under pressure, means

for regulating the pressure of the fluid in the accumulator, a fluid pressure main leading from the accumulator, a branch pipe from said main, a sliding door, a cylinder and piston, one of which is fast to the door and the other to the framework or bulkhead surrounding the door, and the movable part being operated by the fluid in said branch pipe, and a releasing valve located in said branch pipe and operated by hand at low pressures and automatically operated at high pressures, substantially as described. 9th. In a hydraulic system of the character described, the combination with a source of fluid pressure, of an accumulator adapted to contain fluid under pressure and itself operated by fluid from the source of fluid pressure, means for regulating the pressure of the fluid in the accumulator, a fluid pressure main leading from the accumulator, branch pipes from said main, door opening and closing mechanism operated by the fluid in said branch pipes, and releasing valves located in each of said branch pipes and separately operated by hand at low pressures and simultaneously automatically operated at high pressures, substantially as described. 10th. In a hydraulic system of the character described, the combination with a source of fluid pressure, of an accumulator adapted to contain fluid under pressure, and itself operated by fluid from the source of fluid pressure, means for regulating the pressure of the fluid in the accumulator, a fluid pressure main leading from the accumulator, branch pipes from said main, door opening and closing mechanism operated by the fluid in said branch pipes, and releasing valves located in each of said branch pipes and separately operated by hand at low pressures and simultaneously automatically operated at high pressures, substantially as described. 11th. In a hydraulic system of the character described, the combination with a source of fluid pressure, of an accumulator adapted to contain fluid under pressure and itself operated by fluid from the source of fluid pressure, means for regulating the pressure of the fluid in the accumulator, a fluid pressure main leading from the accumulator, branch pipes from said main, a sliding door, a cylinder attached to said door, a fixed piston, and a hollow piston rod connected to said branch pipe and opening into the cylinder, whereby the door is operated by the fluid in said branch pipes, and releasing valves located in each of said branch pipes and separately operated by hand at low pressures and simultaneously automatically operated at high pressures, substantially as described. 12th. In a hydraulic system of the character described, the combination with a source of fluid pressure, of an accumulator adapted to contain a body of fluid under pressure, a plurality of reducing valves for regulating the admission of fluid pressure from said source to said accumulator, a by-pass opening from between said reducing valves into said accumulator, a valve controlling said by-pass, means for operating said valve, and door opening and closing mechanism operated by the fluid pressure from the accumulator, substantially as described. 13th. In a hydraulic system of the character described, the combination with a source of fluid pressure, of an accumulator adapted to contain a body of fluid under pressure, a plurality of reducing valves for regulating the admission of fluid pressure from said source to said accumulator, a by-pass opening from between said reducing valves into said accumulator, a valve controlling said by-pass, a hydraulic system for operating said valve, and door opening and closing mechanism operated by the fluid pressure from the accumulator, substantially as described. 14th. In a hydraulic system of the character described, the combination with a source of fluid pressure, of an accumulator adapted to contain a body of fluid under pressure, a plurality of reducing valves for regulating the admission of fluid pressure from said source to said accumulator, a by-pass opening from between said reducing valves into said accumulator, a valve controlling said by-pass, a hydraulic system operated by pressure from the accumulator for operating said valve, a fluid pressure main connected to said accumulator, branch pipes connected to said main, and door opening and closing mechanism operated by the fluid pressure in said branch pipes, substantially as described. 15th. In a hydraulic system of the character described, the combination with a fluid pressure main and a branch pipe leading therefrom, and means for raising and lowering the pressure in said main, of mechanism operated by the pressure in said branch pipe, and a releasing valve located in said branch pipe, and adapted to be operated by hand at all pressures, and to be operated automatically at high pressures only, substantially as described. 16th. In a hydraulic system of the character described, the combination with a fluid pressure main and a branch pipe leading therefrom, and means for raising and lowering the pressure in said main, of door opening and closing mechanism operated by the pressure in said branch pipe, and a releasing valve located in said branch pipe, and adapted to be operated by hand at all pressures and to be operated automatically at high pressures only, substantially as described. 17th. A releasing valve, for use in apparatus of the character described, comprising a valve casing with two passages therethrough crossing at right angles, and a perforated plug at the intersection of said passages, the said passages being also provided with lateral ports or openings, spring operated valves closing said lateral ports against normal pressures but yielding to high pressures, passages and pipes leading from the rear of said spring operated valves to the mechanism to be operated, and pipes leading from the valve casing to the sources of pressure and to the exhaust, substantially as described. 18th. A releasing valve, for use in apparatus of the character described, comprising a valve casing with two passages therethrough crossing at right angles, and a perforated plug at the intersection of said passages, a hand lever for turning said

plug and means for automatically returning said hand lever to the initial position, the said passages being also provided with lateral ports or openings, spring operated valves closing said lateral ports against normal pressures, but yielding to high pressures, passages and pipes leading from the rear of said spring operated valves to the mechanism to be operated, and pipes leading from the valve casing to the source of pressure and to the exhaust, substantially as described. 19th. The combination with a frame secured to the bulkhead and provided with guides for the edges of the door, of a door sliding in said guides and provided with a plurality of inclined bearing surfaces with projections at the base of said surfaces, a plate sliding between said inclined surfaces and the frame and itself having inclined surfaces oppositely disposed to those on the door, balls or rollers interposed between the inclined surfaces on the door and on the said plate, and means for starting the door before said plate, in opening the door, and for stopping door after said plate, in closing the door, substantially as described. 20th. The combination with a frame secured to the bulkhead and provided with guides for the edges of the door, of a door sliding in said guides and provided with a plurality of inclined bearing surfaces with projections at the base of said surfaces, a plate sliding between said inclined surfaces and the frame and itself having inclined surfaces oppositely disposed to those on the door, balls or rollers interposed between the inclined surfaces on the door and on the said plate, and a pivoted toe adapted to lock said plate against motion when the door is in the early stages of opening or the late stages of closing, substantially as described. 21st. The means for tightening the sides of a sliding door, which consists in providing oppositely inclined surfaces on the door and next the framework, with balls or rollers interposed between the said oppositely inclined surfaces, substantially as and for the purposes described. 22nd. The means for tightening the bottom or edge of a sliding door, comprising a wedge-shaped heel piece on the door, and a pivoted flap piece adapted to engage the said heel piece, with inclined inner face, and springs normally pressing said inner face against the door sill when the door is open, substantially as described. 23rd. The means for tightening the bottom or edge of a sliding door, comprising a wedge-shaped heel piece on the door and a pivoted flap piece adapted to engage the said heel piece, with inclined inner face, and springs normally pressing said inner face against the door sill when the door is open, and rollers engaging said heel piece and pressing said flap piece back against the action of said springs as the door descends, substantially as described. 24th. In a hydraulic system for opening and closing sliding doors or moving other bodies, the combination with a supply pipe from the source of fluid pressure, and an exhaust pipe, of a fixed hollow piston rod with separate passages therethrough to the upper and lower sides of the piston, respectively, a cylinder secured to the door or other body to be moved, double pipes connecting the passages in the piston rod, to the supply pipe, and a four-way valve for connecting one of the passages in the piston rod to the supply pipe, and the other to the exhaust, or *vice versa*, substantially as described. 25th. In a hydraulic system for opening and closing sliding doors or moving other bodies, the combination with a supply pipe from the source of fluid pressure, and an exhaust pipe, of a fixed hollow piston rod with separate passages therethrough to the upper and lower sides of the piston, respectively, a cylinder secured to the door or other body to be moved, double pipes connecting the passages in the piston rod to the supply pipe, and a four-way valve for connecting one of the passages in the piston rod to the supply pipe, and the other to the exhaust, or *vice versa*, with means for operating this valve by hand at all pressures, or automatically at high pressures only, substantially as described. 26th. In a hydraulic system for opening and closing sliding doors, the combination with a door and rigid guides therefor, of a supply pipe from the source of fluid pressure and an exhaust pipe, a fixed hollow piston rod with separate passages therethrough to the upper and lower sides of the piston, respectively, a cylinder secured to the door, double pipes connecting the passages in the piston rod to the supply pipe, a four-way valve for connecting one of the passages in the piston rod to the supply pipe, and the other to the exhaust, or *vice versa*, and tightening devices automatically operated by the motion of the door, substantially as described. 27th. In a hydraulic system for opening and closing sliding doors, the combination with a door and rigid guides therefor, of a supply pipe from the source of fluid pressure and an exhaust pipe, a fixed hollow piston-rod with separate passages therethrough to the upper and lower sides of the piston respectively, a cylinder secured to the door, double pipes connecting the passages in the piston-rod to the supply pipe, a four-way valve for connecting one of the passages in the piston-rod to the supply pipe, and the other to the exhaust, or *vice versa*, and tightening devices automatically operated by the motion of the door, with means for operating this valve by hand at all pressures, or automatically at high pressures only, substantially as described. 28th. In a hydraulic system of the character described, the combination with an operating cylinder, a piston therein, and mechanism operated by said piston, of pipes adapted to contain fluid under pressure connected to each end of said cylinder, a device for indicating the flow of fluid through said pipes, and a hand-operated releasing valve contained in said circuit, substantially as herein described, and shown in figures 9, 10 and 11 of the drawings hereunto annexed. 29th. In a hydraulic system of the character described, the combination with operating cylinder, provided with a piston therein, and mechanism operated by said piston, of means

for injecting fluid under pressure into one end of said operating cylinder, and means for registering the fluid expelled from the opposite end of said cylinder, and a hand-operated releasing-valve contained in said circuit, substantially as herein described and shown in figures 9, 10 and 11 of the drawings hereunto annexed. 30th. In an apparatus of the character described, the combination with a fluid circuit of an operating piston with mechanism operated thereby, an indicating piston moving synchronously with said operating piston, and a hand-operated releasing-valve contained in said circuit, substantially as described. 31st. In a hydraulic system of the character described, the combination with a fluid circuit, an operating cylinder in said circuit, with a piston operated by the fluid, a signalling device for indicating the motion of said piston, and an independently operated releasing-valve for controlling the flow of fluid in said circuit, substantially as described. 32nd. In a hydraulic system of the character described, the combination with a cylinder and an operating piston of a door, and mechanism operated by said piston for moving said door, an indicating cylinder, a double system of pipes connected thereto, a pipe for supplying fluid pressure, and an exhaust pipe, a six-way valve located between said cylinders and adapted to connect said supply pipe with either end of said operating cylinder, to connect the opposite end of the operating cylinder with one end of the indicating cylinder, and to connect the opposite end of the indicating cylinder with the exhaust pipe, and a hand-operated releasing valve contained in said circuit, substantially as described.

No. 58,436. Smoke Consumer. (*Appareil pour consumer la fumée.*)

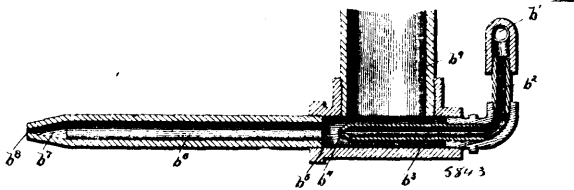

Alfred Pageau and Léon Giguère, both of Montreal, Quebec, Canada, 18th December, 1897; 6 years. (Filed 12nd November, 1897.)

Claim.—1st. The combination with a boiler, of an exterior chamber formed at the top thereof for the collection of gases and smoke, a steam blower located below said boiler, and pipes connecting said exterior chamber and said steam blower, whereby the smoke and gases will be removed from said chamber and passed over the fuel chamber, substantially as described. 2nd. The combination with a boiler, forwardly extending plates secured thereto at its top, and a hinged cover, hingedly connected to said boiler, said cover being adapted to rest on said plates and form a chamber for collecting gases and smoke, of a steam blower located below said boiler, and pipes connected to said chamber and steam blower, whereby the smoke and gases will be removed from said chamber and passed over the fuel chamber, substantially as described. 3rd. The combination with the boiler A, plates *a* 2, and hinged cover *a* 3, of the steam blower B, substantially as described. 4th. The combination with a boiler, of a smoke and gas collecting chamber formed at its front end, series of chambers located below the boiler, pipes connecting said gas collecting chamber and said chambers, a tube mounted in each of said chambers, a pipe connecting each of said tubes to the boilers, and outlets connected to said series of chambers for the combined steam, smoke and gases, said outlets leading over the fuel chamber, substantially as described. 5th. The combination with a boiler having a fuel chamber, of means for passing the smoke and gases generated in said boiler, over the fuel chamber, whereby said smoke and gases will be consumed. 6th. The combination with a boiler having a fuel chamber, of means for gathering the smoke and gases at the top of the boiler, and means for substantially passing said smoke and gases into the fuel chamber above the fire, whereby the smoke and gases will be consumed. 7th. The combination with a boiler having a fuel chamber, of a chamber located at the top of the boiler, and means for passing the contents of said chamber into the fuel chamber over the fire. 8th. The combination with a boiler having a fuel chamber, of a chamber located at the top of the boiler, a steam blower attached to said boiler, and means for connecting said chamber and said steam blower. 9th. The combination with a boiler having a fuel chamber, of a steam blower secured to said boiler and having its outlet in said fuel chamber above the fire, a chamber formed at the top of the boiler, and means for connecting said chamber and said blower, the connection being at a point in rear of the outlet of steam from said blower. 10th. The combination with a boiler having a fuel chamber, of a steam blower secured to said boiler and having its outlet in said fuel chamber above the fire, a chamber formed at the top of the boiler, and means for connecting the said chamber and said blower, the connection being at a point in rear of the outlet of steam from said blower. 11th. The combination with a boiler having a fuel chamber, of a chamber formed at the top of said boiler, a steam blower attached to said boiler, and having its outlet arranged within an enlarged chamber tubes connecting said upper chamber with said enlarged chamber, and means for passing the combined steam and contents of said upper chamber into said fuel chamber and over the fire.

No. 58,437. Combined Fish and Animal Trap.

(*Pidge.*)

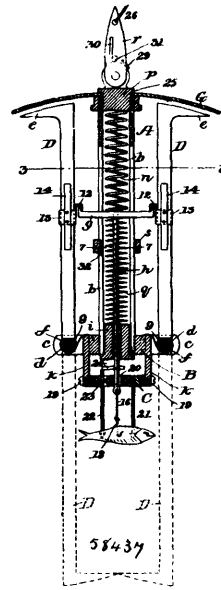

Jacob Cartier, Biddeford, Maine, U.S.A., 18th November, 1897; 6 years. (Filed 15th November, 1897.)

Claim.—1st. A fish and animal trap, comprising a tubular casing provided on each side with a longitudinal slot, spring-actuated arms or levers pivoted at the bottom of the casing and provided with hooks at their outer ends, said arms being adapted to be swung upward into parallelism or nearly so with the casing, a tripping-bar extending transversely across the interior of the casing and projecting on each side through the longitudinal slots thereof, catches on the spring-actuated arms adapted to engage the opposite ends of the tripping-bar, whereby said hooked-arms are held in a raised position against the resistance of their springs when the trap is set, and a bait-holding device for operating the tripping-bar to release the spring-actuated arms, substantially as described. 2nd. In a fish and animal trap, the combination with a tubular casing provided on each side with a longitudinal slot, of spring-actuated arms or levers pivoted at the bottom of the casing and provided at their outer ends with hooks and adapted to be turned upward into parallelism or nearly so with the sides of the casing when the trap is set, a tripping-bar extending transversely across the interior of the casing and having its ends extended through the slots thereof and adapted to engage catches on the spring-actuated arms to hold the latter in a raised position against the resistance of their springs, when the trap is set, a spiral spring placed above the tripping-bar and acting to depress the same when released, a rod attached to the tripping-bar and extending beyond the bottom of the casing and provided with a lateral projection, and a bait-holding device consisting of a cross-bar secured to supports connected with the casing and provided with two barbed bait-rods, one rigidly secured to the cross-bar and the other pivoted thereto in such manner that its upper end will engage the lateral projection on the tripping-bar-rod to hold the same against the pressure of the spring above the same, whereby when the bait is seized, the upper end of the pivoted bait-rod will be moved to release the tripping-bar and spring the trap, substantially as described. 3rd. In a fish and animal trap, the combination with the casing, its spring-actuated arms, the tripping-bar for holding the same in a raised position, and the bait-holding-device for operating the tripping-bar to release said arms, of a curved guard-plate located at the upper end of the tubular casing and extending over the hooked upper ends of the spring-actuated arms when raised, whereby the hooks are protected and prevented from becoming entangled in weeds or the like, substantially as set forth. 4th. In a fish and animal trap, the combination with the tubular casing, of the yoke B carrying the spring-actuated arms D D, said yoke being made removable from the casing substantially as set forth. 5th. In a fish and animal trap, the combination with the slotted tubular casing and the tripping-bar, of the spring-actuated arms provided with catches adjustable thereon and adapted to engage the upturned ends of the tripping-bar, said catches having friction springs bearing on the arms to hold them in place when adjusted, substantially as set forth. 6th. In a fish and animal trap, the combination with the tubular casing provided on each side with a longitudinal slot, having a notch in one of its side walls, of a spring enclosed within the upper portion of the casing, a cylindrical plug or head provided with a tripping-bar extending transversely across the interior of the casing, and adapted to engage the notches in the sides of the longitudinal slots of said casing to hold the head against the resistance of the spring, a loose spear placed within the

tubular casing against the spring-actuated head, and adapted to be discharged by the force of said spring when released, and a long flexible bar or rod resting on a fulcrum and having its end placed beneath the end of the tripping-bar and adapted to be operated to release said bar and spring, by the weight of an animal lying thereon, substantially as described. 7th. In a fish and animal trap, the combination with the tubular casing A provided with longitudinal slots *b* and having plugs fitted into its opposite ends, of the spring-actuated arms D pivoted at the bottom of the casing and provided with hooks at their free ends, the tripping-bar *g* extending across the interior of the casing and out through the slots *b* and engaging catches on the arms D to hold the latter in a raised position, the spiral springs *n, q*, placed one above and the other beneath the tripping-bar *g*, the spring *n* being of greater strength than the spring *q*, a rod *h* secured to the tripping-bar and provided with a pin or projection 24, and a bait-holding device consisting of a cross-bar C secured to hangers or supports *k* and provided with bait-rods 21, 22, the rod 21 being rigidly secured to the cross-bar, and the rod 22 being pivoted thereto and extending above the same to engage the projection 24 on the rod *h* to hold the tripping bar against the resistance of the spring *n*, all constructed to operate substantially in the manner and for the purpose set forth.

No. 58,438. Hair Tonic. (Tonique pour les cheveux.)

Michael John Fleming, Portland, Oregon, U.S.A., 18th December, 1897; 6 years. (Filed 15th November, 1897.)

Claim.—1st. The method of producing the composition hereinbefore described, which consists in mixing water containing iron oxid, with rum and hot bears' grease, then maintaining the mixture for several hours at a heat slightly below 212° Fahrenheit, next successively shaking and thoroughly cooling the mixture, as specified. 2nd. The improved remedy for baldness, consisting of water containing iron oxid, rum, and bears' grease, the proportions being one-half of the water to a double quantity of each of the other ingredients, as specified.

No. 58,439. Lemon Juice Extractor. (Pressoir à citron.)

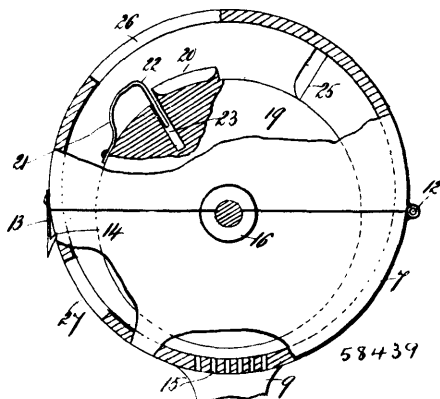

George R. Howell, Southampton, New York, U.S.A., 18th December, 1897; 6 years. (Filed 1st December, 1897.)

Claim.—1st. A device for extracting the juice of lemons or other fruit, comprising a circular casing composed of two parts, the upper part being larger than the lower part, a shaft passing through said casing centrally of the meeting point of said parts, a cylinder or drum mounted on said shaft within said casing, and the upper part of said casing being provided with an opening, and the lower part being perforated, substantially as shown and described. 2nd. A device for extracting juice of lemons or other fruit, comprising a circular casing composed of two parts, the upper part being larger than the lower part, a shaft passing through said casing centrally of the meeting point of said parts, a cylinder or drum mounted on said shaft within said casing, and the upper part of said casing being provided with an opening and the lower part being perforated, said casing being also provided at one side of the opening in the top thereof with an inwardly directed blade, and said drum being provided with a receptacle, for holding the lemon and with a slotted spring which is secured thereto, at one side of said receptacle, substantially as shown and described. 3rd. A device for extracting the juice of lemons or other fruits, consisting of a circular casing which is composed of two parts, the upper part being larger than the lower part and provided with an opening in the top thereof, and being provided with a shaft which passes therethrough, centrally of the meeting surfaces, of said parts, said shaft being provided with a drum or cylinder which is mounted thereon within said casing, substantially as shown and described. 4th. A device for extracting the juice of lemons or other fruits, consisting of a circular casing which is composed of two parts, the upper part being larger than the lower part, and provided with an opening in the top thereof, and a shaft which passes centrally therethrough of the meeting surfaces of said parts, said shaft being provided with a drum or

cylinder which is mounted thereon within said casing, and said casing being also provided with an opening, which is formed in the perimeter of the lower part thereof, substantially as shown and described.

No. 58,440. Shirt. (Chemise.)

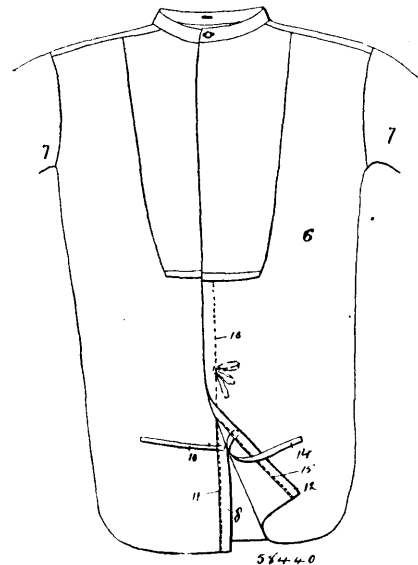

Richard James Tooke, Montreal, Quebec, Canada, 18th December, 1897; 6 years. (Filed 1st December, 1897.)

Claim.—1st. In a shirt, the combination with the edges of the opening thereof having facings, of lengths of tape, for the purpose set forth. 2nd. A shirt having a front opening, bands 8 and 12, lengths 10 and 14 of tape, and lines 11 and 15 of stitching, all arranged substantially as described and for the purpose set forth.

No. 58,441. Hub or Bearings of Wheels. (Moyeu ou coussinet de roues.)

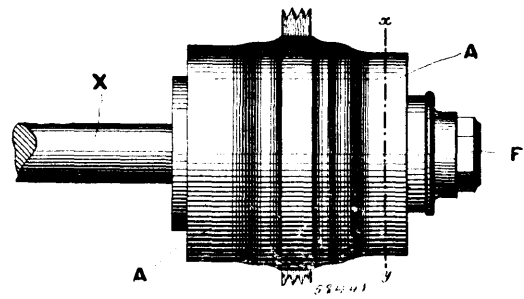

Benjamin Crowther and David Roper, both of West Bromwich Stafford, England, 18th December, 1897; 6 years. (Filed 1st December, 1897.)

Claim.—1st. The improvements in the hub or bearings of wheels, consisting of a wood or other hub A, having recessed ends to receive the cups B and B', which are provided with a groove or grooves in combination with divided cones which are locked together and kept at the desired distance apart by the distance-tube or cylinder T, the bearings sliding upon the round or other axle X, after which the cones are located to the said axle by the end lock-nuts and washers or their equivalents, substantially as herein set forth and as upon the accompanying sheet of drawings. 2nd. Hubs or bearings of wheels, consisting of the combination of a hub with the solid cups and split cones at each end, the said cones being held apart by the distance-tube and locked in position, in the manner substantially as herein set forth and as shown upon the drawings. 3rd. For wheel hubs, round or square axle, removably connected with cones sliding thereon in pairs, with their locking-screws and distance-tube for holding them apart, as shown, the whole being tightened together against the shoulders of the axle so as to prevent them from turning, in the manner substantially as herein set forth and shown. 4th. In wheel hubs or bearings, adjusting the cones by screws, in the manner substantially as herein set forth and as shown upon the drawings. 5th. In wheel hubs or bearings, the distance-tube or tubes for holding the cones apart, in the manner substantially as and for the purpose herein set forth and shown. 6th. The wheel hubs and bearings, and their parts, substantially as herein set forth, and as shown on the accompanying drawings.

No. 58,442. Rotary Engine. (Machine rotatoire.)

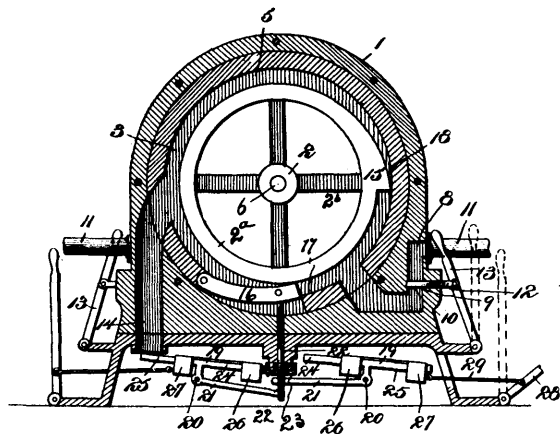

Silvester E. Ferguson, Eureka Springs, Arkansas, U.S.A., 18th December, 1897; 6 years. (Filed 29th November, 1897.)

Claim.—1st. A rotary engine having a casing comprising side walls and an annular outer wall having a continuous groove in its inner surface, a concentric piston having a rim forming the inner of the concentric walls of the casing, and provided with a peripheral web projecting radially from the outer surface of its rim, and peripherally-seated in said groove in the outer wall of the casing, to divide the interior of the casing into co-axial non-communicating cylinders, moving abutments carried by said web respectively at its opposite sides, to operate in said cylinders, the abutment in one cylinder being reversed in position to that in the other cylinder, relatively-reversed fixed abutments disposed respectively in the cylinders and yieldingly held in their operative positions in the paths of the moving abutments, means for securing either fixed abutment in a retracted position, out of the path of the co-operating moving abutments, and valve mechanism for controlling the admission of motive agent, whereby the same may be applied to either of said cylinders, substantially as described. 2nd. A rotary engine having a casing, a concentric piston provided with a moving abutment having a cam-face, a fixed abutment arranged in the path of the moving abutment and capable of radial movement into and out of the path of said moving abutment, and means for yieldingly holding the fixed abutment in its operative position, said means including a rocker operatively connected with the fixed abutment and having adjustable opposing counterpoises adapted to hold the abutment either extended or retracted, substantially as specified. 3rd. In a rotary engine, the combination with a cylinder, a concentric piston having a moving abutment, and a fixed abutment mounted in the cylinder for movement into and out of the path of the moving abutment, of a rocker operatively connected to said fixed abutment and having oppositely-extended guides, and connected weights mounted respectively upon said guides and adapted to be arranged at relatively different distances from the fulcrum of the rocker to vary the position of the fixed abutment, substantially as specified. 4th. In a rotary engine, the combination with a cylinder, a piston having a moving abutment, and a pivotal fixed abutment, of a rocker having an adjustable actuating weight, a stem connecting the fixed abutment with an arm of said rocker, and means for securing the fixed abutment in its depressed position, substantially as specified. 5th. In a rotary engine, the combination with a cylinder, a piston having a moving abutment, and a fixed abutment mounted for movement into and out of the path of the moving abutment, of a rocker having oppositely-extended guides, connections between the fixed abutment and the rocker, connected weights mounted respectively upon the guides of the rocker, and means, as a hand-lever, for simultaneously shifting the weights to vary their positions with relation to the fulcrum of the rocker, substantially as specified. 6th. In a rotary engine, the combination with a cylinder, a piston having a moving abutment, and a fixed abutment adapted to be extended to normally occupy a position in operative relation with the piston, and mounted for retraction or folding by gravity, of actuating means, operatively connected with the stem of the fixed abutment, for holding the fixed abutment yieldingly extended in opposition to gravity, and devices operatively connected with said actuating means, for relieving the stem of the abutment of the pressure thereof, whereby said abutment is allowed to fold by gravity, substantially as specified.

No. 58,443. Machine for Making Stove Pipe Elbows. (Machine pour faire les coudres de tuyaux de poêles.)

The Patent Elbow Company, assignee of Louis Joseph Herard, all of Montreal, Quebec, Canada, 18th December, 1897; 15 years. (Filed 8th April, 1897.)

Claim.—1st. In a machine for making stove pipe elbows, a bearing head having an oscillating or rocking movement and a

tilinear movement, with actuating mechanism for imparting such movement, for the purpose set forth. 2nd. In a machine for mak-

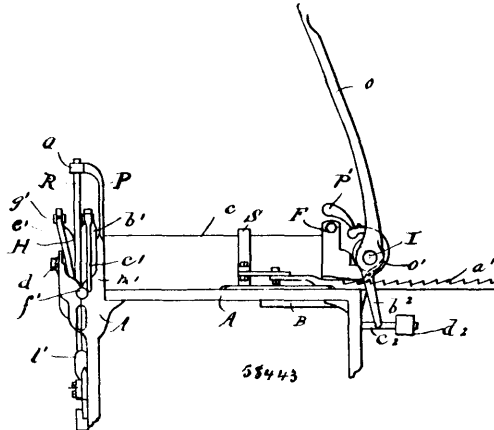

ing stove pipe elbows, an intact bearing head having an oscillating or rocking movement and a rectilinear movement with actuating mechanism for imparting such movement, for the purpose set forth. 3rd. In a machine for making stove pipe elbows, a movable bearing plate having a rectilinear movement within the pipe to be operated upon, and means for actuating such plate, for the purpose set forth. 4th. In machines for making stove pipe elbows, the combination of a support for the pipe to be operated upon, means for retaining the pipe in position while being operated upon and creasing jaws, a movable bearing plate and a bearing head, the bearing head having a hinged or pivotal connection with the bearing plate and adapted to be rocked or oscillated toward and from such plate, and both head and plate adapted to be moved inwards rectilinearly to compress and fold over the crease previously formed by the creasing jaws, with means for rocking said head and moving same together with said plate rectilinearly, as and for the purpose set forth. 5th. In machines for making stove pipe elbows, the mechanism for compressing and folding over a crease, comprising a support, a rectilinearly movable bearing plate and an oscillating bearing head pivoted thereto, the head and plate adapted to receive the crease between them and the bearing head adapted upon being oscillated toward the bearing plate to compress the crease against such plate and upon further movement, rectilinearly with the bearing plate, to fold the crease into a pleat, and actuating mechanism for said bearing head and plate, as and for the purpose set forth. 6th. The combination of the cylinder C, bearing plate E, bearing head N, connecting rod M, crank shaft I, having crank K, and cam L, sleeve D, and slide block F, with the creasing jaw R, and jaws b', c', substantially as described. 7th. The combination of the gripping jaws c' and b', creasing jaws R, with the cylinder C, bearing plate E, bearing head N, with a mechanism substantially as described whereby the bearing head N, and bearing plate E, are moved backwards rectilinearly to form the crease into a pleat, the whole substantially as described.

No. 58,444. Firemen's Hose Nozzle. (Lance de boyaux.)

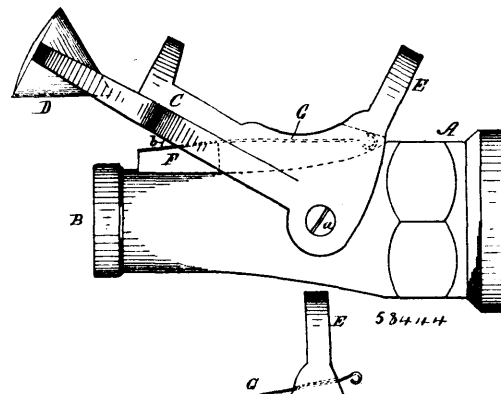

William Mathen, Brockville, Ontario, Canada, 18th December, 1897; 6 years. (Filed 28th October, 1897.)

Claim.—1st. In a fireman's hose nozzle, the combination therewith of a pivoted frame carrying a cone, a handle plate attached to the frame, for raising or depressing the cone, when raised, by which a full stream of water can be thrown from the nozzle, or a spray, by altering the position of the cone, substantially as specified. 2nd. A cone attached to a movable frame pivoted to a hose nozzle and a spring secured to the same, to hold the cone opposite to the mouth

of the nozzle for spraying, or hold it above the mouth of the nozzle for full stream, substantially as specified. 3rd. The cone D, secured to a frame C, pivoted to a nozzle A, a handle plate E, on the frame to move it, a spring G, secured to the nozzle A, and made to press upwards on the frame C, to hold the cone D horizontally opposite to the mouth of the nozzle, or hold it in a slanting direction above the mouth of the nozzle, substantially as and for the purpose specified.

No. 58,445. Wick Raiser. (Monte-mèches.)

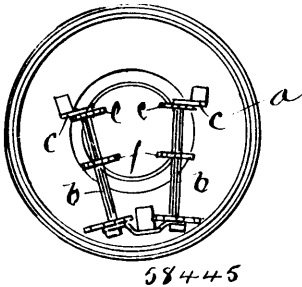

Eusebio F. Cabezola, Trenton, New Jersey, U.S.A., 18th December, 1897; 6 years. (Filed 20th November, 1897.)

Claim.—1st. The combination with a lamp-wick, of a pair of horizontal spindles provided with toothed-wheels engaging the wick, gear-wheels on said spindles, a vertical spindle extending through the top of the bowl, and having a worm-gear thereon, and a bracket supporting one end of the horizontal spindles and the vertical spindle between and in engagement with said gear-wheels. 2nd. The combination with a lamp-wick, of a pair of horizontal spindles provided with toothed-wheels engaging the wick, a vertical spindle extending through the top of the bowl and provided with a worm-gear, gear-wheels on the outer ends of the horizontal spindles and having teeth the width of the space between the spiral projection on the worm-gear, and a bracket having arms supporting one end of said horizontal spindles and the vertical spindle between and in engagement with said gear-wheels. 3rd. The combination with a lamp-wick, of a pair of spindles provided with toothed-wheels engaging the wick, gear-wheels on said spindles, a compound bracket supporting one end of the spindles and having an intermediate and integral step, a worm-gear supported on said step and in engagement with the gear-wheels.

No. 58,446. Advertising Medium. (Moyen d'annoncer.)

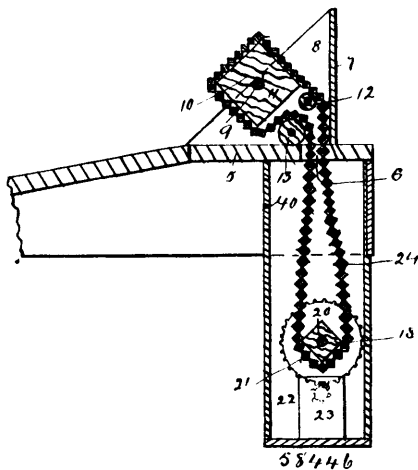

Robert Bayley, Montreal, Quebec, Canada, 18th December, 1897; 6 years. (Filed 28th May, 1897.)

Claim.—1st. An advertising medium comprising an enclosing casing, an aperture in the same, an operating-roll and an endless belt, the latter formed of a series of bars, angular in cross-section, each bar presenting two or more exposed sides or surfaces at right angles to each other and suitably marked, and such bars being flexibly jointed together for the purpose set forth. 2nd. An advertising medium comprising an enclosing casing, an annular operating roll and an endless belt, the latter formed of a series of bars, each bar having two or more exposed sides or surfaces at right angles to each other, bearing separate sections or strips of paper previously united in a single piece and marked or printed with advertising matter, such as a word, aggregate parts of each letter of which are carried by each bar, the single piece being afterward affixed to

such bars and then divided to form such separate sections, and such bars being flexibly jointed together for the purpose set forth. 3rd. An advertising medium comprising an enclosing casing, an aperture in the same, a rectangular operating roll located in said opening so that two sides thereof may be exposed at one time, and an endless belt, the latter formed of a series of rectangular bars approximately square in cross-section, flexibly jointed together with two of the diametrically opposite corners of each bar and suitably marked, for the purpose set forth. 4th. An advertising medium comprising an enclosing casing, a rectangular operating-roll and an endless belt, the latter formed of a series of rectangular bars flexibly jointed together at their diametrically opposite corners and each bar having its two exposed sides or surfaces suitably marked, for the purpose set forth. 5th. In an advertising medium, an operating-roll angular in cross-section to afford plane surfaces, and a series of bars square in cross-section and disposed about such operating-roll with two of the diametrically opposite corners of each bar in line with two of the diametrically opposite corners of the adjacent bars, so that their surfaces will be at an angle to the plane surfaces of such roll, and suitable advertising matter on two of the surfaces of each bar, for the purpose set forth. 6th. In an advertising medium, the combination of a roll rectangular in cross-section, an endless belt adapted to take over said roll and being of greater length than the combined width of all of the sides of said roll, and an enclosing casing adapted to enclose a portion of said belt and roll, and said roll having three of its sides exposed, for the purpose set forth. 7th. An advertising medium, comprising a horizontal section having a slot therethrough, an enclosing casing extending below said horizontal section, and communicating with said slot, a vertical section extending above said horizontal section and longitudinally of and adjacent to said slot, and a pair of triangular bearing pieces each secured at one end and transversely of said slot and to the top of said horizontal section and the adjacent side of said vertical section, a roll rectangular in cross-section, and rotatably mounted in bearings formed in the inclined edges of said bearing pieces, an operating-roll located within said enclosing casing, means for rotating said operating-roll, and an endless belt taking around said rolls, said belt consisting of a series of bars square in cross-section and disposed about said upper roll with two of the diametrically opposite corners of each bar in line with two of the diametrically opposite corners of the adjacent bars so that their surfaces will be at an angle to the plane surfaces of such upper roll, and suitable advertising matter on two of the surfaces of each bar, for the purposes set forth. 8th. In combination with a desk, table, or the like, having a slot in the top thereof, an enclosing casing 40, bearing pieces 8, 8, a roll 10, anti-friction rollers 12 and 13, operating-roll 18, an endless belt 24, and means for actuating said operating roll, substantially as described and for the purpose set forth.

No. 58,447. Cyclometer Bracket.

(Console pour cyclomètres.)

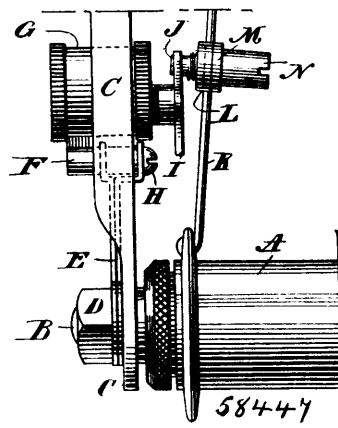

William Clifford Homan, Meriden, Connecticut, U.S.A., 18th December, 1897; 6 years. (Filed 21st October, 1897.)

Claim.—1st. A cyclometer bracket, comprising a bifurcated supporting member, one of its forked arms being offset at a greater distance than the other arm. 2nd. A supporting means for a barrel cyclometer, being a carrier projecting from one side of the barrel body, a slot in said carrier, a bifurcated supporting arm embracing that part of the carrier to one side of said slot. 3rd. A supporting means for a barrel cyclometer, being a carrier projecting from one side of the barrel body, a slot in said carrier about midway in its length, a bifurcated supporting arm embracing that part of the carrier to one side of said slot, one of said forked arms being offset farther than the other, and a set-screw. 4th. A cyclometer striker having its rear end screw-threaded and provided with a longitudinal slot, an adjusting nut thereon, and a set-nut to the rear of said adjusting nut. 5th. A cyclometer striker having its rear end screw-

threaded and provided with a longitudinal slot, an adjusting nut thereon, a groove in the rear surface of said adjusting nut, a washer, and a set-nut to the rear of said adjusting nut.

No. 58,448. Combined Fire and Burglar Alarm.
(*Avertisseur à sonnerie.*)

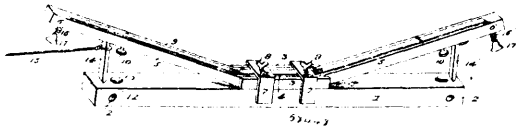

James Henry Ellis, Prescott, Arkansas, U.S.A., 18th December, 1897; 6 years. (Filed 16th November, 1897.)

Claim.—A combined fire and burglar alarm, comprising the bar 1, provided with the studs 12, 12, in combination with the pivoted levers 5, 5, formed with the hammer-heads 10, 10, the clamps 7, 7, provided with the thumb-screws 8, 8, the spring 9, centrally secured in said clamps, the detachable props 14, 14', and the jingle-bells 17, 17', located in the path of the free ends of said levers 5, 5, substantially as shown and described.

No. 58,449. Picture Matting Cutter.
(*Appareil pour découper des figures sur les nattes.*)

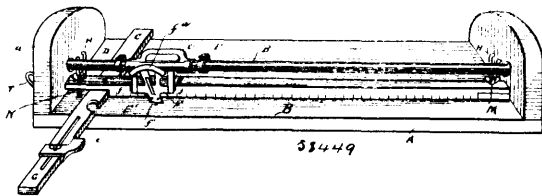

William H. Murdoch, Youngstown, Ohio, U.S.A., 18th December, 1897; 6 years. (Filed 17th November, 1897.)

Claim.—1st. In a device for cutting picture matting, the combination with a knife carriage and knife, of a guide bar upon which said knife carriage is movable, a spring for pressing said guide bar in one direction, a cam upon the end of said guide bar and a plate engaged by said cam, substantially as described and for the purpose set forth. 2nd. In a device for cutting picture matting, the combination of the rod for guiding the cutting device, a spring for pressing the said rod in one direction, and means for forcing and locking said rod against the action of said spring, substantially as described. 3rd. In a device for cutting picture matting, the combination of the knife carriage, the knife adjustably supported thereby, a guide rod upon which said carriage travels, springs for forcing said guide rod in one direction, and means for locking said rod against the action of said springs, substantially as described. 4th. In a device for cutting picture matting, the combination with the frame having end walls formed with openings, plates secured to said end walls and formed with projections adjacent to said openings, a spring-pressed guide rod extending loosely through said openings and provided with cams for engaging said projections, a handle for said rod, and cutting means guided by said rod, substantially as shown and described. 5th. In a device for cutting picture matting, the combination of a base piece, a binding bar extending longitudinally of said base piece, springs at either end of said bar resting upon said base piece and seated within the underside of the binding bar, bolts arranged to pass through the said base piece, springs and binding bar, and provided with thumb nuts upon their upper ends whereby said binding bar may be adjusted against the tension of the springs, and the cam pivoted to the lower end of one of the said bolts and adapted to be turned upon said pivot whereby said binding bar is caused to clam said picture matting against said base piece, substantially as described. 6th. In a device for cutting picture matting, the combination of a frame, a binding bar, coil springs at either end of said bar adapted to normally hold in elevated above said frame, bolts provided with thumb nuts adapted to adjust said bar against the tension of said springs, and a cam having a lever formed integral pivoted to the lower end of one of said bolts, and adapted to be turned upon said pivot, whereby said clamping bar is forced downward against the tension of said springs, substantially as described.

No. 58,450. Match Delivery-Box. (*Boîte à allumettes.*)

Rodney Stewart Norton, Winnipeg, Manitoba, Canada, 18th December, 1897; 6 years. (Filed 11th November, 1897.)

Claim.—1st. In a match delivery-box, the combination with the front and rear curvulate plates, having the front plate overlapping the edge of the rear plate, of the roller located to the front of the overlapping edges and provided with pins and turning-knob, as and for the purpose specified. 2nd. In a match delivery-box, the combination with the curvulate plates, provided with the upper slots and screw connecting them to the back and front of the box, of the roller provided with aligned pins and the plates D, G, extending to

and past the roller, and provided with slots *a*, *g*, and the opening H, all arranged as and for the purpose specified. 3rd. In a match

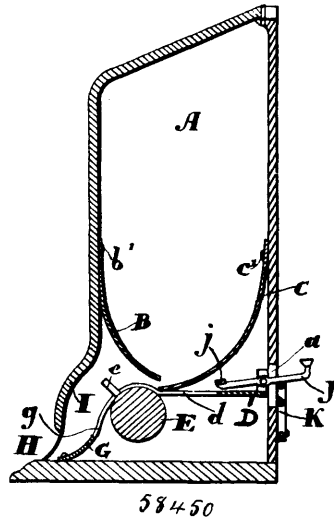

delivery-machine, the combination with the adjustably-supported curvulate plates, having the front plate overlapping the rear one, of the lever extending through a slot in the back plate and the hook catch for same, as and for the purpose specified.

No. 58,451. Method of Manufacturing Jars, etc.
(*Méthode de fabrication de jarres, etc.*)

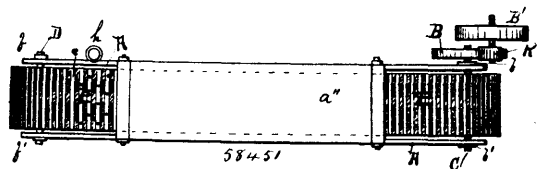

David A. Gordon, Wallaceburg, Ontario, Canada, 18th December, 1897; 6 years. (Filed 4th November, 1897.)

Claim.—1st. The combination of the frame or casing A, having the chamber H as a drain, and the chamber F as a kiln containing the steam-pipes G, substantially as specified. 2nd. The combination of the casing A, having the chambers H and F, the steam-pipes G, and the movable rack or carrier E, operated over the pulleys *c* and *d*, substantially as specified and set forth. 3rd. The combination of the casing A, having the chambers H and F, the steam-pipes G, the movable rack E with or without the pins *e'* operated over the pulleys *c* and *d*, and the mechanism necessary for the operation of the same, substantially as and for the purposes specified and set forth.

No. 58,452. Propulsion and Construction of Boats.
(*Propulsion et construction de vaisseaux*)

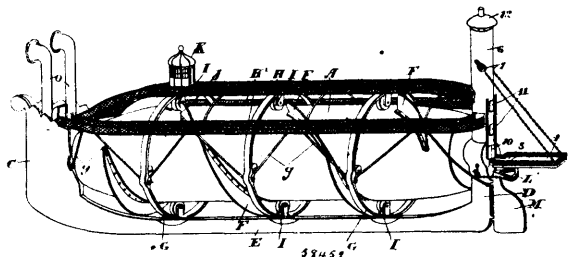

Hugh Robertson Shaw, Rosseau, Ontario, Canada, 18th December, 1897; 6 years. (Filed 3rd November, 1897.)

Claim.—1st. A boat comprising stem and stern portions and keel connecting the same at the bottom thereof, an inner cylindrical shell rigidly connected to the stem and stern portions of the boat above the keel and forming a living compartment, and an outer cylindrical shell having bearings on the inner cylindrical shell and provided with convolute flanges, and means for driving the same, as and for the purpose specified. 2nd. A boat comprising stem and stern portions and keel connecting the same at the bottom thereof, an inner cylindrical shell rigidly connected to the stem and stern portions of the boat above the keel and forming a living compart-

ment, and a outer cylindrical shell having bearings on the inner cylindrical shell provided with convolute flanges, means for driving the same, and hurricane deck bridge or bridges connecting the bow or stern portion to the stern portion above the shells, as and for the purpose specified. 3rd. A boat comprising stem and stern portions and keel connecting the same at the bottom thereof, an inner cylindrical shell rigidly connected to the stem and stern portions of the boat above the keel and forming a living compartment, and an outer cylindrical shell having bearings on the inner cylindrical shell and provided with convolute flanges, means for driving the same, hurricane deck bridge or bridges connecting the bow or stern portion to the stern portion above the shells, and rings surrounding the shells and secured to the keel and hurricane deck bridges, as and for the purpose specified. 4th. A boat comprising stem and stern portions and keel connecting the same at the bottom thereof, an inner cylindrical shell rigidly connected to the stem and stern portions of the boat above the keel and forming a living compartment, and an outer cylindrical shell having bearings on the inner cylindrical shell and provided with convolute flanges, means for driving the shell, hurricane deck bridge or bridges connecting the bow or stern portion to the stern portion above the shells, rings surrounding the shells and secured to the keel and hurricane deck bridges, rollers supported in suitable bearings within the said rings and designed to lie adjacent to the cylindrical shell and openings in the convolute flanges to permit the rollers passing through the convolute flanges as the shell rotates, as and for the purpose specified. 5th. In a boat, the stem and stern portions and keel connecting the same at the bottom thereof, an inner cylindrical shell provided with suitable end walls, the hollow trunnions leading outwardly from such walls and rigidly connected to the stem and stern portions, the outer cylindrical shell having central bearings on the inner cylindrical shell and having suitable end walls, the trunnions extending inwardly from the end walls over the hollow trunnions of the inner shell, the bearings between the stationary trunnions and the trunnions of the outer shell, and means for driving the outer shell, as and for the purpose specified. 6th. In a boat, the stem and stern portions and keel connecting the same at the bottom thereof, an inner cylindrical shell provided with suitable end walls, the hollow trunnions leading outwardly from such walls and rigidly connected to the stem and stern portions, the outer cylindrical shell having central bearings on the inner cylindrical shell and having suitable end walls, the trunnions extending inwardly from the end walls over the hollow trunnions of the inner shell, the bearings between the stationary trunnions and the trunnions of the outer shell, a suitably driven engine and shaft extending through the ends of the inner shell and pinions on the outer end of the shaft meshing with the gear rings on the trunnions, as and for the purpose specified. 7th. In a boat, the stem and stern portions and keel connecting the same at the bottom thereof, the inner cylindrical shell provided with suitable end walls, the hollow trunnions leading outwardly from such walls and rigidly connected to the stem and stern portions, the outer cylindrical shell having bearings on the inner cylindrical shell and convolute flanges extending throughout its length, the forward air funnels extending down through the bow portion and through the trunnions into the interior shell and the stern air shaft extending from the stem trunnions upwardly and provided with a suitable cowl, as and for the purpose specified. 8th. In a boat, the stem and stern portions and keel connecting the same at the top thereof, the inner cylindrical shell provided with suitable end walls, the hollow trunnions leading outwardly from such walls and rigidly connected to the stem and stern portions, the outer cylindrical shell having bearings on the inner cylindrical shell and convolute flanges extending throughout its length, the forward air funnels extending down through the bow portion and through the trunnions into the interior shell, the stern air shaft extending from the stern trunnions upwardly and provided with a suitable cowl and the smoke pipe leading from the engine room to and through the stern shaft, as and for the purpose specified. 9th. In a boat, the stem and stern portions and keel connecting the same at the top thereof, the inner cylindrical shell provided with suitable end walls, the hollow trunnions leading outwardly from such walls and rigidly connected to the stem and stern portions, the outer cylindrical shell having bearings on the inner cylindrical shell and convolute flanges extending throughout its length, the front and rear shafts communicating with the hollow trunnions and extending up to the upper decks and the spiral stairs located therein, as and for the purpose specified. 10th. In a boat, the stem and stern portions and keel connecting the same at the top thereof, the inner cylindrical shell provided with suitable end walls, the hollow trunnions leading outwardly from such walls and rigidly connected to the stem and stern portions, the outer cylindrical shell having bearings on the inner cylindrical shell and convolute flanges extending throughout its length and the rudder fastened to the front post and manipulated, as shown and as specified. 11th. In combination the outer and inner shells constructed as specified and the outer shell connected to the

stem and stern portions, the keel connecting the stem and stern portions, the hollow trunnion in the stem portion, the platform extending out from the hollow trunnion, the landing platform swivelled on such latter platform, the supporting and raising chains for the landing platform suitably operated, the entrance doors in the end of the hollow trunnions, the air shaft, doors in the same and the guiding ribs all arranged, as and for the purpose specified. 13th. A boat comprising stem and stern portions and keel connecting same at the bottom thereof, a cylindrical shell having bearings in the stem and stern portions and provided with convolute flanges and means for driving same, as and for the purpose specified.

No. 58,453. Sounding Board. (Table d'harmonie.)

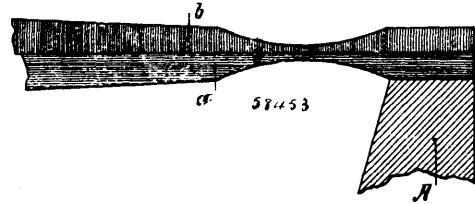

Constantin Schmidlein, Berlin, Germany, 18th December, 1897; 6 years. (Filed 29th October, 1897.)

Claim.—1st. The combination with a support of a ribless sounding board having its margins reduced towards the places where it is supported. 2nd. The combination with a support of a ribless sounding board composed of wooden plates placed one upon the other with the grain crossing the said board having its margins reduced towards the places where it is supported.

No. 58,454. Animal Trap. (Piège.)

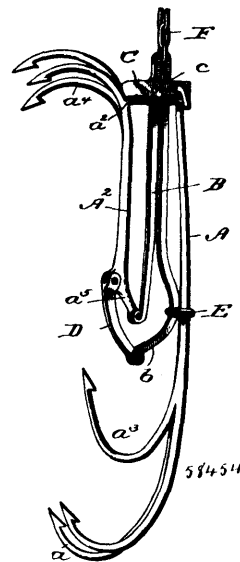

David Sandling McCollum, Keno, Oregon, U.S.A., 18th December, 1897; 6 years. (Filed 22nd October, 1897.)

Claim.—1st. An animal trap comprising two sets of hook-bearing bars, one of which is relatively movable with relation to the other, which is, then, relatively stationary, a spring for actuating the relatively movable bar, a sear pivotally connected with the spring and adapted to engage a trigger-catch on the movable bar, and to be released therefrom by pressure applied to the hooks of the relatively stationary bar, substantially as described. 2nd. An animal trap comprising an approximately V-shaped spring, a yoke, constituting a sear, pivoted to one of the members of the spring and projecting beyond the sides thereof, a grab-hook bearing bar connected with one end of the sear, a second grab-hook bearing bar pivoted to the end of one of the members of the spring, and having a trigger-catch adapted to be brought into engagement with the sear to hold the latter bar raised, and a link connecting the movable hook-bar with the other member of the spring, said spring constituting, at once, a hook-actuating spring and the means for supporting the trap in position for use, substantially as described. 3rd. An animal trap comprising an approximately V-shaped spring, a yoke, constituting a sear, pivoted to one of the members of the spring and projecting beyond the sides thereof, a grab-hook bearing bar connected with one end of the sear, a second grab-bearing bar pivoted to one end of one of the members of the spring, and having a trigger-catch adapted to be brought into engagement with the sear to hold

the latter bar raised, a link connecting the movable hook-bar with the other member of the spring, said spring constituting, at once, a hook-actuating spring and the means for supporting the trap in position for use, and a band or ring for holding the spring and stationary hook-bar together, substantially as described.

No. 58,455. Pegging Machine. (Machine à cheviller.)

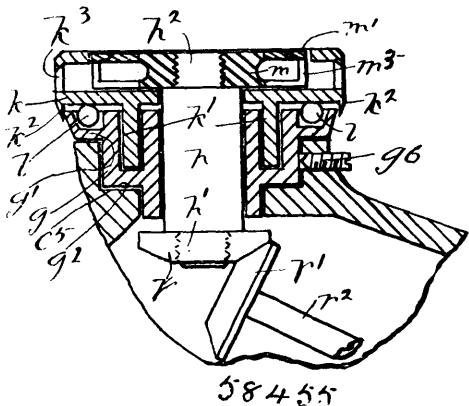

Elouild Duplessis, Emile Arthur Marchildon, Mathilda Massé, and Louis H. Marin, all of St. Hyacinthe, Quebec, Canada, 20th December, 1897; 6 years. (Filed 24th June, 1897.)

Claim.—1st. In a pegging machine, the combination with a rotary cutter consisting of a ring saw-toothed on its inner edge, a work-supporting section located within and concentrically of said ring, for the purpose set forth. 2nd. In a pegging machine, a rotary cutter being adapted to rotate about and eccentrically of the point at which the pegs are driven, for the purpose set forth. 3rd. In a pegging machine, a rotary cutter consisting of a ring saw-toothed on its inner edge and connected to a rotatable hub section adapted to partially support the work, for the purpose set forth. 4th. In a pegging machine, a rotary cutter consisting of a hub section, a ring having its inner edge formed with saw-teeth, a series of downwardly off-set arms or braces connecting the underside of said ring rigidly to the lower end of said hub, for the purpose set forth. 5th. In a pegging machine, a rotary cutter consisting of a hub section, a ring having its inner edge formed with saw-teeth, the upper surface of such ring being located on a line with the upper face of such hub, a series of downwardly off-set arms or braces connecting the underside of said ring rigidly to the lower end of said hub, means for rotating said cutter, and means for retaining same against displacement, for the purpose set forth. 6th. In combination with the nose of the horn or work-support of a pegging machine, an aperture concentric of the upper surface of said nose, a rotatable cap consisting of a plate having a downwardly projecting flange adapted to take into a circular recess, formed at the upper end of said nose and concentric of the aperture therethrough, said plate extending over a second recess encircling said first-mentioned recess, and adapted to support said cap, a cutter mounted upon the upper end of a rotatable spindle extending through said aperture, the edge of said plate being upwardly curved and extended inwardly to closely encircle said cutter and furnish a bearing surface for the work, sections of said upwardly curved portion of the plate being cut away, and means for rotating said spindle, for the purpose set forth. 7th. In combination with the nose of the horn or work-support of a pegging machine, an aperture concentric of the upper surface of said nose, a rotatable cap consisting of a plate having a downwardly projecting flange adapted to take into a circular recess, formed at the upper end of said nose and concentric of the aperture therethrough, said plate extending over a second recess encircling said first-mentioned recess, and adapted to support said cap, a series of rollers located in said last-mentioned recess and adapted to support said cap, a cutter mounted upon the upper end of a rotatable spindle extending through said aperture, the edge of said plate being upwardly curved and extended inwardly to closely encircle said cutter and furnish a bearing surface for the work, sections of said upwardly curved portion of the plate being cut away and the lower edge thereof having a downwardly extending flange formed thereon and adapted to overlap the edge of said nose, and means for rotating said spindle, for the purpose set forth. 8th. In combination with the nose of the horn or work-support of a pegging machine, an aperture concentric of the upper surface of said nose, a rotatable cap consisting of a plate having a downwardly projecting flange adapted to take into a circular recess formed at the upper end of said nose and concentric of the aperture therethrough, said plate extending over a second recess encircling said first-mentioned recess, a series of rollers located in said last-mentioned recess and adapted to support said cap, a cutter mounted upon the upper end of a rotatable spindle extending through said aperture, the edge of said plate being upwardly curved and extended inwardly to closely encircle said cutter and furnish a bearing surface for the work, sections of said upwardly curved portion of the plate being cut away and the lower edge thereof having a downwardly extending flange formed thereon and adapted to overlap the edge of said nose, means for rotating said bearing section in place, and means for rotating said spindle, for the purpose set forth. 9th. In combination with the nose of the horn or work support of a pegging machine, an aperture concentric of the upper surface of said nose, a rotatable cap consisting of a plate having a downwardly projecting flange adapted to take into a circular recess formed at

the upper end of 'said nose' and concentric of the aperture therethrough, said plate extending over a second recess encircling said first mentioned recess, a series of rollers located in said last mentioned recess and adapted to support said cap, a rotary cutter consisting of a hub section provided with a screw-threaded central perforation, a ring having its inner edge formed with saw teeth, the upper surface of such ring being located on a line with the upper face of such hub, a series of downwardly off-set arms or braces connecting the underside of said ring rigidly to the lower end of said hub, said cutter being mounted through its perforated hub upon the upper screw-threaded end of a rotatable spindle extending through said aperture, the edge of said plate being upwardly curved and extended inwardly to closely encircle said cutter and furnish a bearing surface for the work, sections of the plate being cut away, and means for rotating said spindle, for the purpose set forth. 10th. In combination with the nose of the horn or work-support of a pegging machine, an aperture concentric of the upper surface of said nose, a rotatable cap consisting of a plate having a downwardly projecting flange adapted to take into a circular recess formed at the upper end of said nose and concentric of the aperture therethrough, said plate extending over a second recess encircling said first mentioned recess, a series of rollers located in said last mentioned recess and adapted to support said cap, a rotary cutter consisting of a hub section, provided with a screw-threaded vertical perforation, a ring having its inner edge formed with saw teeth, the upper surface of such ring being located on a line with the upper face of such hub, a series of downwardly off-set arms or braces connecting the underside of said ring rigidly to the lower end of said hub, said cutter being mounted through its perforated hub upon the upper screw-threaded end of a rotatable spindle extending through said aperture, the edge of said plate being upwardly curved and extended inwardly to closely encircle said cutter and furnish a bearing surface for the work, sections of said upwardly curved portion of the plate being cut away and the lower edge thereof, having a downwardly extending flange formed thereon and adapted to overlap the edge of said nose, and means for rotating said spindle, for the purpose set forth. 11th. In combination with the nose of the horn or work-support of a pegging machine, said nose being formed with a central aperture and recessed to form a shoulder, a circular bearing section diminished in diameter to form a shoulder near the upper end thereof, and further diminished in diameter to form a second shoulder near the lower end thereof, the upper shoulder being adapted to rest upon the top edge of the nose, and the lower shoulder being adapted to rest upon the shoulder formed by said recess in the nose, said bearing section being provided with a central aperture, and a recess formed in the upper face of such bearing section and encircling said aperture and a second recess similarly located and encircling said first mentioned recess, a rotatable cap consisting of a plate having a downwardly projecting flange adapted to take into said first mentioned circular recess, said plate extending over said last mentioned recess, a series of rollers located in said last mentioned recess, and adapted to support said cap, a cutter mounted upon the upper end of a rotatable spindle extending through said aperture, the edge of said plate being upwardly curved and extended inwardly to closely encircle said cutter and furnish a bearing surface for the work, sections of said upwardly curved portion of the plate being cut away, means for retaining said bearing section in place, and means for rotating said spindle, for the purpose set forth. 12th. In combination with the nose of the horn or work-support of a pegging machine, said nose being formed with a central aperture and recessed to form a shoulder, a circular bearing section diminished in diameter to form a shoulder near the upper end thereof, and further diminished in diameter to form a second shoulder near the lower end thereof, the upper shoulder being adapted to rest upon the top edge of the nose and the lower shoulder being adapted to rest upon the shoulder formed by said recess in the nose, said bearing section being provided with a central aperture, and a recess formed in the upper face of such bearing section and encircling said aperture, and a second recess similarly located and encircling said first mentioned recess, a rotatable cap consisting of a plate having a downwardly projecting flange adapted to take into a circular recess formed at the upper end of said nose and concentric of the aperture therethrough, said plate extending over a second recess encircling said first mentioned recess, a series of rollers located in said last mentioned recess and adapted to support said cap, a cutter mounted upon the upper end of a rotatable spindle extending through said aperture, the edge of said plate being upwardly curved and extended inwardly to closely encircle said cutter and furnish a bearing surface for the work, sections of said upwardly curved portion of the plate being cut away and the lower edge thereof having a downwardly extending flange formed thereon and adapted to overlap the edge of said nose, means for retaining said bearing section in place, and means for rotating said spindle, for the purpose set forth. 13th. In combination with the nose of the horn or work-support of a pegging machine, said nose being formed with a central aperture and recessed to form a shoulder, a circular bearing section diminished in diameter to form a shoulder near the upper end thereof, and further diminished in diameter to form a second shoulder near the lower end thereof, the upper shoulder being adapted to rest upon the top edge of the nose and the lower shoulder being adapted to rest upon the shoulder formed by said recess in the nose, said bearing section being provided with a central aperture, and a recess formed in the upper

face of such bearing section and encircling said aperture and a second recess similarly located and encircling said first mentioned recess, a rotatable cap consisting of a plate having a downwardly projecting flange adapted to take into said first mentioned circular recess, said plate extending over said last mentioned recess, a series of rollers located in said last mentioned recess and adapted to support said cap, a rotary cutter consisting of a hub section provided with a screw-threaded central perforation, a ring having its inner edge formed with saw teeth, the upper surface of such ring being located on a line with the upper face of such hub, a series of downwardly off-set arms or braces connecting the underside of said ring rigidly to the lower end of said hub, said cutter being mounted through its perforated hub upon the upper screw-threaded end of a rotatable spindle extending through said aperture, the edge of said plate being upwardly curved and extended inwardly to closely encircle said cutter and furnish a bearing surface for the work, sections of said upwardly curved portion of the plate being cut away, means for retaining said bearing section in place, and means for rotating said spindle, for the purpose set forth. 14th. In combination with the nose of the horn or work support of a pegging machine, said nose being formed with a central aperture and recessed to form a shoulder, a circular bearing section diminished in diameter to form a shoulder near the upper end thereof, and further diminished in diameter to form a second shoulder near the lower end thereof, the upper shoulder being adapted to rest upon the top edge of the nose and the lower shoulder being adapted to rest upon the shoulder formed by said recess in the nose, said bearing section being provided with a central aperture, and a recess formed in the upper face of such bearing section and encircling said aperture and a second recess similarly located and encircling said first mentioned recess, a rotatable cap consisting of a plate having a downwardly projecting flange adapted to take into said first mentioned circular recess, said plate extending over said last mentioned recess, a series of rollers located in said last mentioned recess and adapted to support said cap, a rotary cutter consisting of a hub section provided with a screw-threaded central perforation, a ring having its inner edge formed with saw teeth, the upper surface of such ring being located on a line with the upper face of such hub, a series of downwardly off-set arms or braces connecting the underside of said ring rigidly to the lower end of said hub, said cutter being mounted through its perforated hub upon the upper screw-threaded end of a rotatable spindle extending through said aperture, the edge of said plate being upwardly curved and extended inwardly to closely encircle said cutter and furnish a bearing surface for the work, sections of said upwardly curved portion of the plate being cut away and the lower edge thereof having a downwardly extending flange formed thereon and adapted to overlap the edge of said nose, means for retaining said bearing section in place, and means for rotating said spindle, for the purpose set forth. 15th. In a pegging machine, the combination with the pedestal thereof having a vertical guideway formed thereon, and a bracket b^2 carried by said frame above and in vertical line with said guideway, a sliding bar located in said guideway, a vertically adjustable screw carried by said bracket and in line with the upper end of said sliding bar, a bracket projection formed near the upper end of said sliding bar and having its forward end perforated, a guiding spindle screw-threaded into the forward end of said first mentioned bracket, said spindle having its lower end extended in diameter to form a shoulder and adapted to take through the perforation in the bracket projection carried by said sliding bar, a perforated disc adapted to take over the upper portion of said guiding spindle, a nut screwed upon the screw-threaded portion of said spindle below its carrying bracket, a helical spring encircling said spindle and adapted to bear between said nut and disc, said sliding bar carrying a horn or work-support, and treadle mechanism for moving said sliding bar to and from said bracket b^2 , for the purpose set forth. 16th. In combination with the pedestal and driving shaft of a pegging machine, a perforated forwardly projecting downwardly inclined bracket, carried by said pedestal, a conical standard having its lower end diminished and screw-threaded, and adapted to take through the perforation in said bracket and receive a retaining nut therein, a horn or work-support formed with a perforated rearward extension and a perforated upwardly off-set portion both adapted to take over said standard, the upper end of said horn being off-set and the centre of the nose thereof located in the axial line of said horn or work-support, for the purpose set forth. 17th. In a pegging machine, the combination with the pedestal thereof having a vertical guideway formed thereon, and a bracket carried by said frame above and in vertical line with said guideway, a sliding bar located in said guideway, a vertically adjustable screw carried by said bracket and in line with the upper end of said sliding bar and having its forward end perforated, a guiding spindle screw-threaded into the forward end of said first mentioned bracket, said spindle having its lower end extended in diameter to form a shoulder and adapted to take through the perforation in the bracket projection carried by said sliding bar, a perforated disc adapted to take over the upper portion of said guiding spindle, a nut screwed upon the screw-threaded portion of said spindle below its carrying bracket, a helical spring encircling said spindle and adapted to bear between said nut and disc, a perforated forwardly projecting downwardly inclined bracket carried by said sliding bar, a conical standard having its lower end diminished and screw-threaded, and adapted to take through the perforation in said bracket and receive a retaining nut

thereon, a horn or work-support formed with a perforated rearward extension and a perforated upwardly off-set portion, both adapted to take over said standard, the upper end of said horn being off-set and the centre of the nose thereof located in the axial line of said horn or work-support, for the purpose set forth.

No. 58,456. Range Boiler. (*Chaudière de poêles de cuisine.*)

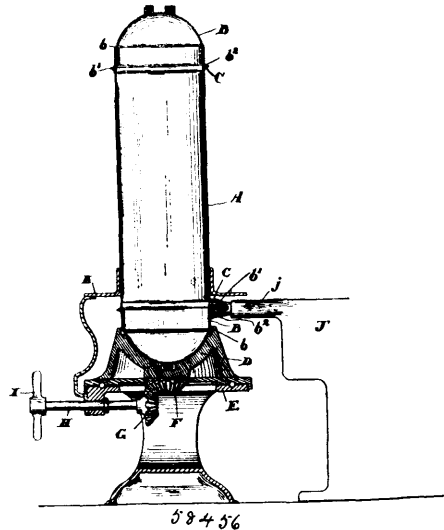

58456

The Booth Copper Company (Limited), assignee of William Henry Oliver, both of Toronto, Ontario, Canada, 20th December, 1897; 6 years. (Filed 27th November, 1897.)

Claim.—1st. As a new article of manufacture, a copper range boiler having a cylindrical portion and flanged head brazed to the ends of the cylindrical portion, as and for the purpose specified. 2nd. As a new article of manufacture, a copper range boiler comprising a cylindrical portion, a head provided with a cylindrical flange and terminating flaring flange, and a spelter joint formed between the flaring flange and the cylindrical portion as and for the purpose specified. 3rd. As a new article of manufacture, a copper range boiler comprising a cylindrical portion, a head or heads provided with a terminating flange fitting on the end or ends of the cylindrical portion of the boiler, and a brazed joint formed between the flange and the cylindrical portion, as and for the purpose specified. 4th. As a new article of manufacture, a copper range boiler comprising a cylindrical portion, a head or heads provided with a terminating flange fitting on the end or ends of the cylindrical portion, and a brazed joint formed between the flange and the cylindrical portion, the flange being turned over to cover the brazed joint and form a head finish, as and for the purpose specified. 5th. The herein described method of manufacturing copper range boilers, consisting in placing the flanged head over the cylindrical end of the boiler, so that a recess is formed between the termination of the flange and the cylindrical portion of the boiler, filling such space with spelter, and then applying heat thereto, so as to form a brazed joint, as and for the purpose specified. 6th. The herein described method of manufacturing copper range boilers, consisting in placing the flanged head over the cylindrical end of the boiler so that a recess is formed between the termination of the flange and the cylindrical portion of the boiler, placing on each side of the joint heat non-conducting shields, inserting spelter in the recess, and finally applying heat thereto so as to form a brazed joint, as and for the purpose specified.

No. 58,457. Material for the Construction and Decoration of Buildings. (*Matériel pour la construction et décoration des batisses.*)

David Hislop Ferguson, Richard William Smith and Robert Thomas Hopper, all of Montreal, Quebec, Canada, 20th December, 1897; 6 years. (Filed 21st October, 1897.)

Claim.—A decorative material in imitation of marble or other ornamental stone capable of being divided into veneers by sawing, composed of hardened mineral fibrous masses separately and distinctly coloured, the colours and markings extending through the material so that both surfaces and all parts between the surfaces shall have similar colours and markings as in the natural stone, for the purpose set forth.

No. 58,458. Bearing-Sleeve for Car Axles.

(*Manchon de coussinet pour essieux de chars.*)

The American Railway Electric Light Company, New York, assignee of Patrick Kennedy, Brooklyn, both in the State of New York, U.S.A., 20th December, 1897; 6 years. (Filed 2nd December, 1897.)

ways below the chain and in the same vertical plane as the compressing device, and suitable operating mechanism. 7th. A machine for compressing and trimming cigarettes, comprising a pair of knives, an endless belt passing between said knives, a series of compressing dies carried by said belt, and means for keeping the dies closed as they pass between the knives. 8th. A cigarette machine, comprising means for compressing the cigarettes into elliptical form and means for trimming the ends of the cigarette simultaneously with the compressing thereof. 9th. In a cigarette machine, the combination with a continuously moving apron, and compressing-dies carried by said apron, a knife in proximity to the apron, and means for operating the apron, dies and knife, whereby the ends of the cigarettes are trimmed. 10th. In a cigarette machine, the combination with an apron, and compressing-dies carried by said apron, of means for closing the dies, and means for opening the same. 11th. In a cigarette machine, a compressing-die having two portions hinged together, and means for retaining the two portions in their opened and in their closed positions.

No. 58,463. Envelope Sealer.

(Appareil à sceller les enveloppes.)

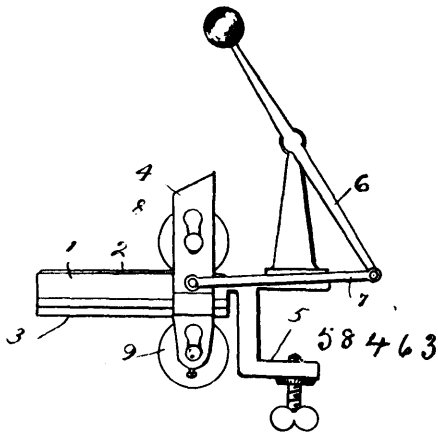

James H. Fearis, Connersville, Indiana, U.S.A., 21st December, 1897; 6 years. (Filed 23rd October, 1897.)

Claim.—1st. In an envelope-sealer, the combination, substantially as set forth, of a fixed flat pad having a moistening surface adapted to receive flatly at one time the entire gummed surface of the gummed flap of an envelope, a pressing-agent at said moistening surface and adapted to press the envelope flap against said surface, and mechanism for giving motion to said pressing-agent so as to permit the flap to be presented to said surface, and then press the flap to said surface, and then permit said flap to be removed. 2nd. In an envelope-sealer, the combination, substantially as set forth, of a fixed flat pad having a moistening surface adapted to receive at one time the entire gummed surface of the gummed flap of an envelope, a carriage mounted to move across said pad, a roller mounted in said carriage and bearing against said pad, and mechanism for giving traversing motion to said carriage. 3rd. In an envelope-sealer, the combination, substantially as set forth, of a fixed flat pad having a moistening surface with an area as great as that of the gummed flap of the envelope, a support holding said pad in an elevated position with said moistening surface downward, a carriage arranged to traverse said pad, a roller mounted in said carriage under said pad, and engaging the moistening surface of the pad, and means for traversing said carriage across said pad. 4th. In an envelope-sealer, the combination, substantially as set forth, of a pad having its lower surface formed of absorptive yielding material, a filling of absorptive material above said lower surface and adapted to be charged with water, and keep the said lower surface moistened, and a perforated pan disposed within the central upper portion of said absorbent material and displacing only said upper-central portion. 5th. In an envelope-sealer, the combination, substantially as set forth, of a tablet having a dry surface and a moistening surface, a carriage arranged to traverse said tablet, rollers mounted in said carriage and engaging the surface of the tablet, and mechanism for giving traversing motion to said carriage. 6th. In an envelope-sealer, the combination, substantially as set forth, of a tablet presenting a surface upwardly and carrying a pad presenting a moistening surface downwardly, a support connected with said tablet and adapted to support the same horizontally with both its surfaces accessible, a carriage arranged to traverse said tablet, rollers mounted in said carriage, and engaging the surfaces of the tablet, and mechanism for giving traversing motion to said carriage.

No. 58,464. Paper Weight. (Poids pour papier.)

Emanuel C. Gipe, Freeport, Illinois, U.S.A., 21st December, 1897; 6 years. (Filed 1st March, 1897.)

Claim.—1st. The combination of the shell A, having the upright grooves, a^2 , in the edges, depressions, a^1 , to form shoulders in the

grooves, the block B, lying within said shell, and the flexible clasp E, having a middle portion, c , bearing upward against the bottom

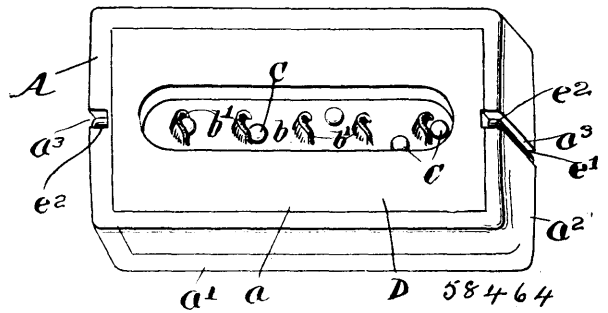

of the block, the upturned portions e^1 , resting in the grooves, a^3 , and the hooked ends, e^2 , engaging the shoulders in said grooves, substantially as described. 2nd. The combination with the shell A, having the upright grooves, a^3 , in its edges, said grooves being extended horizontally at the top to form shoulders and at the bottom across the lower margin of the shell, of the block B within said shell, and the flexible clasp having the upwardly-convex middle portion, c , bearing upward against the bottom, the upward portions, e^1 , resting in the grooves, a^3 , and held therein against lateral movement, and the hooked ends, e^2 , engaging the upper horizontal extensions of the grooves and holding the parts together, substantially as described.

No. 58,465. Inkstand. (Encrier.)

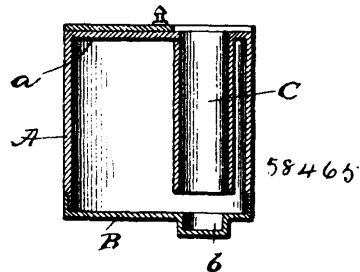

James William Jacobus, Great Neck, New York, U.S.A., 21st December, 1897; 6 years. (Filed 9th November, 1897.)

Claim.—1st. The herein described inkstand or bottle, which is provided with a removable bottom in which is formed at one side thereof, a chamber or depression, said inkstand or bottle being also provided with a closed top, at one side of which is an open tube, the lower end of which projects downwardly, to near the bottom and immediately over said chamber or depression and said top being provided with a sliding plate which is adapted to close the upper end of said tube, substantially as shown and described. 2nd. The herein described inkstand or bottle, which is composed of a body portion provided with a closed top, and a removable bottom, said removable bottom being provided at one side with a circular chamber or depression and said top being provided with an open tube at one side, the lower end of which extends downwardly to near the bottom, and immediately over said circular chamber, or depression, and said top being also provided with a sliding plate, which is adapted to close the open upper end of said tube, substantially as shown and described.

No. 58,466. Billiard Table Cushion.

(Bande de billiard.)

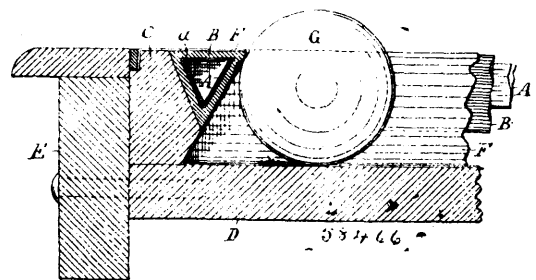

Thomas William Meachem, Onondago Valley, New York, U.S.A., 21st December, 1897; 6 years. (Filed 26th November, 1897.)

Claim.—1st. The combination of a V or U-shaped metallic spring and a rubber cushion completely enclosing the spring, as set forth. 2nd. The combination of a V or U-shaped metallic spring and a triangular rubber cushion completely enclosing the spring, as set forth. 3rd. The combination of a V or U-shaped metallic spring, a

rubber cushion completely enclosing the spring, and a fabric cemented to the rubber on the interior walls of the cushion, as set forth. 4th. The combination of a V or U-shaped metallic spring, a rubber cushion shaped triangular in cross-section, entirely surrounding the spring, and cloth between the rubber and the spring, as set forth. 5th. The combination of a V or U-shaped metallic spring, an angular rubber cushion completely enclosing the spring, cloth secured to the interior of the cushion and cloth completely enclosing the cushion, as set forth. 6th. The combination of a V or U-shaped metallic spring, an angular rubber cushion completely enclosing the spring, cloth secured to the inner walls of the cushion, and stiffening strips at one or more of the angles of the cushion embedded in the rubber, substantially as described and shown. 7th. The combination of a V or U-shaped metallic spring having its edges bent inward, and an angular rubber cushion completely enclosing the spring, as set forth. 8th. The combination of a V or U-shaped metallic spring, an angular rubber cushion completely enclosing the spring, cloth secured to the inner walls of the cushion, and a cushion rail surrounding a billiard table to support the cushion, substantially as described and shown.

No. 58,467. Holders for Cigarettes or analogous Articles. (Porte-cigarettes, etc.)

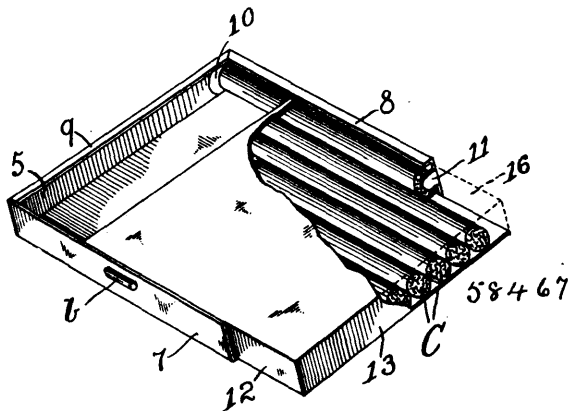

Harry Hayes Kerr, Philadelphia, Pennsylvania, U.S.A., 21st December, 1897; 6 years. (Filed 25th October, 1897.)

Claim.—1st. The combination, in a holder for cigarettes, etc., of a rectangular bottom shell having three vertical walls, two of which at right angles to each other are provided with overlapping or flanged upper edges, and the front flanged wall near a corner of said shell is provided with a slot 10, and the side flanged wall is provided with a lug 11, and the opposite unflanged side wall being provided with an internal locking projection *b*, and a rectangular top shell provided with three vertical and unflanged edge walls, in one of which is provided an oblong slot to permit said lug 11 to engage therein, said top shell having an internal pocket for the reception of cigarettes or similar articles maintained in position therein under tension of a leaf-spring *D*, and said articles adapted to be liberated through said slot 10, by causing the articles one by one to engage said lug 11, and said top shell provided in one side wall with an internal projection *b*¹, adapted to lock with said projection *b*, substantially as and for the purposes described. 2nd. A holder for cigarettes, etc., consisting of two complementary shells, whereof one is provided with a slot 10, in one end wall, a lug 11, projecting from the edge of the open end and indentations in the side vertical walls forming projections 8 and 9, and whereof the other member is provided with a slotted internal pocket having a transverse projection 23, internal indentations forming projections 20 and 21, in the side vertical walls, and a leaf-spring *D*, mounted in said pocket and the respective ends bearing against one of the side walls and the inserted articles of said pocket, substantially as and for the purposes described.

No. 58,468. Cannon. (Canon.)

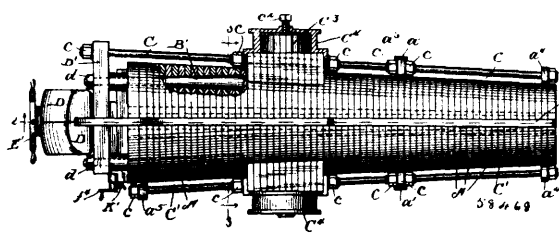

Edwin James Blood, Chicago, Illinois, U.S.A., 21st December, 1897; 6 years. (Filed 23rd November, 1897.)

Claim.—1st. A cannon, comprising layers or plates provided with a central opening tapering towards the muzzle, means for securing the plates together, the discs or plates in the rear portion of the

cannon having openings tapering rearwardly, a removable tube or barrel located in the central opening and correspondingly tapered on its outer surface, rods tapering rearwardly located in said rearwardly tapering openings, and means for securing said rods therein, substantially as described. 2nd. A cannon, comprising layers or plates provided with a central opening tapering towards the muzzle, means for securing the said discs or plates together, the discs or plates in the rear portion of the cannon having openings tapering rearwardly, a tube or barrel located in the central opening and correspondingly tapered on its outer surface, rods tapering rearwardly located in and extending through said rearwardly tapering openings, a cross-head secured on the extension of said rods at a distance from the rear disc or plate, substantially as described. 3rd. A cannon, comprising layers or plates provided with a central opening tapering towards the muzzle, means for securing the said layers or plates together, the discs or plates in the rear portion of the cannon having openings tapering rearwardly, a tube or barrel located in the central opening and correspondingly tapered on its outer surface, rods tapering rearwardly located in and extending through said rearwardly tapering openings, a cross-head secured on the extension of said rods, and a breech-block carrying a firing mechanism interposed and operating between the cross-head and rear part of the bore, a firing mechanism on said breech-block, and an inclined adjustable piece between the breech-block and cross-head, substantially as described. 4th. A cannon, comprising layers or plates provided with a central opening tapering towards the muzzle, means for securing the said layers or plates together, the discs or plates in the rear portion of the cannon having openings tapering rearwardly, a tube or barrel located in said opening, reinforcing ribs engaging the disc at the muzzle end of the cannon and extending past the rear end thereof, a cross-head secured to the rear end of the cannon at a distance therefrom, bearing-pieces secured to the rear ends of the ribs and having in their adjacent surfaces annular recesses provided with annular enlargements adjacent to the cross-head, a sleeve having on its inner end an annular flange and located in said recesses, a tubular shaft having on its inner end an inclined annular flange, said shaft located in said sleeve, and the flange thereof interposed between the bearing-pieces and the cross-head, substantially as described. 5th. A cannon, comprising layers or plates provided with a central opening tapering towards the muzzle, means for securing the said layers or plates together, a correspondingly tapered tube or barrel located in said opening, reinforcing ribs engaging the disc at the muzzle end of the cannon and extending past the rear end thereof, a cross-head secured to the rear end of the cannon at a distance therefrom, bearing-pieces secured to the rear ends of the ribs, and having in their adjacent surfaces annular recesses, provided with annular enlargements adjacent to the cross-head, a sleeve having on its inner end an annular flange and located in said recesses, a tubular shaft having on its inner end an inclined annular flange, said shaft located in said sleeve, and the flange thereof interposed between the bearing-pieces and the cross-head, a breech-block carrying a firing mechanism, an inclined piece adjustably secured on said block, said piece and block adapted to be interposed between the cross-head and rear end of the bore in the cannon, substantially as described. 6th. A cannon comprising a body, a cross-head secured to the body a distance from the rear of the bore in the body and having an opening in alignment with the bore for the insertion of a projectile, the inner end of said opening being located a sufficient distance from the rear end of the bore to admit of the insertion of a breech-block between it and the bore, the cross-head forming a support for the breech-block when the gun is fired, substantially as described. 7th. A cannon comprising a body, a cross-head secured to the body at a distance from the rear of the bore in the body and having an opening in alignment with the bore for the insertion of a projectile, the inner end of said opening being located a sufficient distance from the rear end of the bore, a breech-block located between the inner end of the opening in the cross-head and the rear end of the bore of the gun, the cross-head being formed to support the breech-block, when the gun is fired, substantially as described. 8th. A cannon comprising a body, a cross-head secured to the body at a distance from the rear of the bore in the body and having an opening in alignment with the bore for the insertion of a projectile, the inner end of said opening being located a sufficient distance from the rear end of the bore, a removable inner barrel located therein, a cross-head secured to the body at a distance from the rear end of the bore of said barrel and having an opening in alignment with said bore for the insertion of a projectile, a breech-block locked between the inner end of the opening in the cross-head and the rear end of the bore in the barrel, the cross-head being formed to support the breech-block when the gun is fired, substantially as described.

No. 58,469. Cold Blast Tubular Lantern. (Lanterne.)

Ernest Schultz, Hamilton, Ontario, and Walter Grose, Montreal, Quebec, both in Canada, 21st December, 1897; 6 years. (Filed 23rd June, 1897.)

Claim.—1st. In a cold blast tubular lantern, spiral springs *J* attached to the guide wires *H* connected to the globe holder and to

the tubes, or lugs *k* secured to the tubes, for the purpose of pulling down the globe and globe holder after being raised for any purpose,

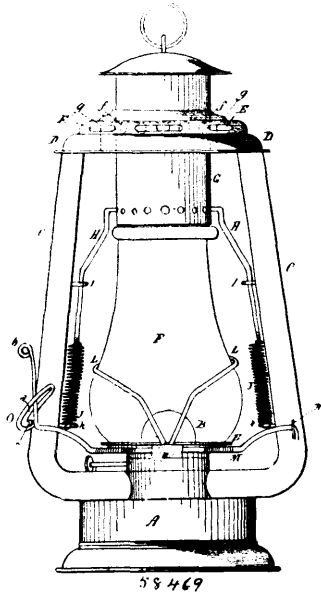

substantially as specified. 2nd. The combination of the crank-shaped globe lifting wire rod *M* attached to the globe disc *E*, and one tube *C*, and the notch *c*, in the slotted plate *O*, attached to the opposite tube to receive the said wire rod *M*, and hold the globe and disc up when elevated above the burner, substantially as specified. 3rd. The formation of the top *D* of the exterior air chamber, constructed with horizontal openings *E'* in the roof, and an annular band *g*, secured in the interior of the said air chamber, to deflect the wind entering the opening *E'*, and the air openings *f*, in the globe holder, substantially as specified.

No. 58,470. Means or Apparatus for Viewing Stereoscopic Pictures, etc. (*Moyen ou appareil pour voir les images stéréoscopiques.*)

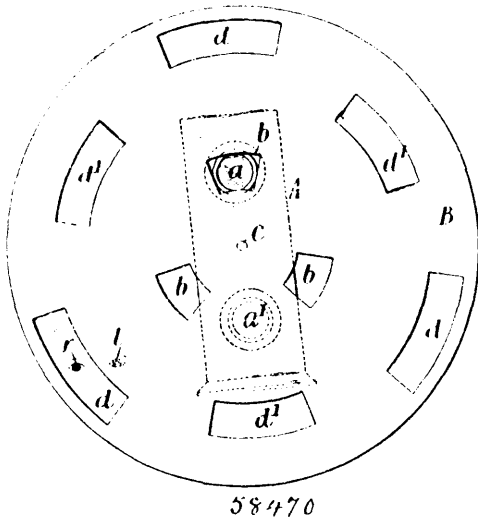

Thomas Cunningham Porter, Eton College, Bucks, England, 21st December, 1897; 6 years. (Filed 9th July, 1897.)

Claim.—1st. The process of displaying stereoscopic pictures, consisting in bringing into the field of vision of an observer alternately and in quick succession each of two complementary stereoscopic pictures, the eyes of the observer being so screened that one eye sees only one of the pair of pictures and the other eye sees only the other of the pair of pictures. 2nd. The process of displaying stereoscopic pictures in a cinematograph, consisting in so arranging the series of pictures that one of each pair of complementary pictures in the series shall appear in the field of vision of an observer immediately and in quick succession after the other complementary picture of the pair, the eyes of the observer being so screened that one eye can see only one of each pair of complementary pictures and the other eye can see only the other of each pair of complementary pictures. 3rd.

The process of displaying pictures consisting in bringing into the field of vision of an observer alternately and in quick succession two entirely different pictures, the eyes of the observer being so screened that either one or other of the pictures alone or a blend or mixture of the two pictures can be seen by the observer, substantially as hereinbefore described. 4th. Apparatus for the purpose set forth, consisting of one or two optical lanterns, devices arranged to throw upon a screen alternately and in quick succession each picture of the complementary pair and a device adapted to alternately and synchronously cover and uncover the two eyes of an observer so that each eye only views its corresponding picture, substantially as described.

No. 58,471. Mouth Speculum. (*Spéculum pour la bouche.*)

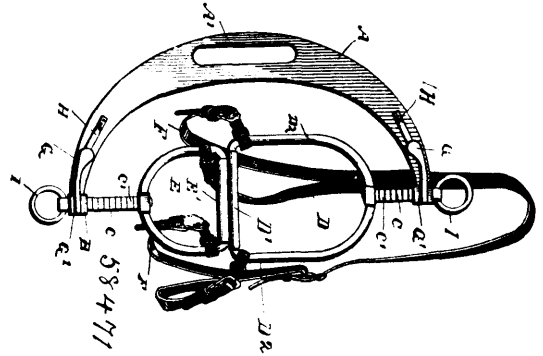

J. Olly Hymer, Concordia, Missouri, U.S.A., 21st December, 1897; 6 years. (Filed 13th September, 1897.)

Claim.—1st. In a veterinary speculum, the combination with the supporting bow or yoke, of the upper and lower jaws, and the adjusting pins attached to the jaws and passing through the upper and lower ends of the bow or yoke, substantially as shown and described. 2nd. In a veterinary speculum, the combination with the supporting bow or yoke, of the upper and lower jaws, the upper and lower adjusting pins attached to said jaws, and passing through the upper and lower ends of the yoke, said pins being adjustable in said ends, but held against rotation, substantially as shown and described. 3rd. In a veterinary speculum, the combination with the supporting bow or yoke, of the upper and lower jaws, the upper and lower adjusting pins pivotally connected to the said upper and lower jaws being adjustable in the upper and lower ends of the supporting bow or yoke, and means of securing the said pins in either adjusted position, substantially as shown and described. 4th. In a veterinary speculum, the combination with the supporting bow or yoke, of the upper and lower jaws, having the upper and lower bits or bars, covered with leather or rubber, the adjusting pins pivotally connected to the said jaws and passing through the upper and lower ends of the supporting bow or yoke, and the spring-actuated lever catches adapted to secure said adjusting pins, substantially as shown and described. 5th. In a veterinary speculum, the combination with the supporting bow or yoke, having bosses at its upper and lower ends, said bosses having polygonal apertures therein, the adjusting pins working in the said apertures, and polygonal shape in cross section and snugly fitting therein, said pins having their faces notched or ratched, the spring actuated lever pivoted upon the lower ends of the bow or yoke, and adapted to engage the notched or ratchet face of the pins, the upper and lower jaws pivotally attached to the upper and lower pins, and the bridle straps connected with the upper and lower jaws, substantially as shown and described.

No. 58,472. Pocket Knife. (*Canif.*)

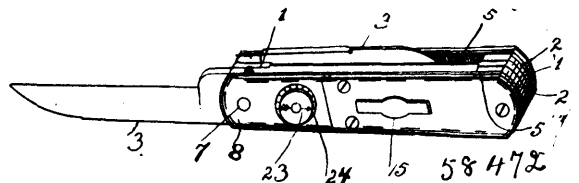

John Ball, Jeanesville, Pennsylvania, U.S.A., 21st December, 1897; 6 years. (Filed 1st October, 1897.)

Claim—1st. In a knife, a suitable handle, and a blade pivotally connected thereto in combination with a cover pivotally connected to the handle, a bolt carried by said handle, a suitable eye on the handle with which said bolt may engage, a disc having a notch to engage said bolt and means for rotating said disc, substantially as described. 2nd. In a knife the combination with a suitable handle, of a pivoted blade, a pivoted cover adapted to engage said blade for swinging the latter inward or outward, a bolt on the cover adapted to engage an eye on the handle for holding the cover locked, a disc arranged within the cover and having a notch for engaging said bolt,

and a milled head arranged outside of said cover, and connected fixedly to said disc for rotating it, substantially as described. 3rd. In a knife the combination with a suitable handle, of a pivoted blade, a pivoted cover for actuating said blade, a bolt mounted in said cover for engagement with an eye on the handle, an escutcheon or name plate for reciprocating said bolt, a notched disc for engaging and locking said bolt, and a milled head arranged outside of the cover for turning said disc, said head being provided with a pointer or indicator adapted to be registered with one or more marks or graduations on the cover, substantially as and for the purpose described.

No. 58,473. Dental Handpiece. (*Poignée pour appareil dentaire.*)

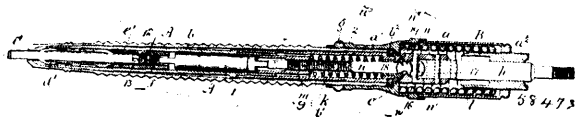

Johannes Theodor Pedersen, Woodside, New York, U.S.A., 21st December, 1897; 6 years. (Filed 22nd November, 1897.)

Claim.—1st. The combination in a dental handpiece, of a case adapted to being held in the hand, a tool-holder within the case, a driving-shaft adapted to being connected to the flexible shaft of the dental engine, an internal spring surrounding a portion of the driving-shaft for giving end movement to the tool-holder to grasp the tool, and devices having opposing curved bearing-faces adapted to rock on one another and acting to compress the spring and positively move a portion of the driving-shaft longitudinally to remove the pressure on the tool-holder and permit the same to expand and release the tool when the rear part of the shaft is swung or deflected, substantially as set forth. 2nd. The combination in a dental handpiece, of a case adapted to be grasped by the hand, a spring connected with the rear end of such case, a tubular case surrounding the spring, and bearing at one end against the rear end of the case whereby the spring is distended when the rear part of the case is deflected out of line with the hand portion of the case and such tubular case is restored into line with the case by the action of the spring, substantially as set forth. 3rd. The combination in a dental handpiece, of a case adapted to being grasped by the hand, and having a collar at its rear end, a driving-shaft adapted to being connected to the flexible shaft of the dental engine, a screw-collar surrounding and sliding upon such shaft, a spring connected at one end with the screw-collar and at the other end to the collar of the handpiece, a tubular case around the spring with a nut at one end upon the screw-collar for adjusting the tension of the spring, and devices having opposing curved bearing-faces for allowing the driving-shaft and tube to be turned or deflected into an angular position to the hand portion of the case and restored into line by the action of the spring, substantially as set forth. 4th. The combination in a dental handpiece, of a case adapted to being grasped by the hand, a tool-holder to receive and grasp the tool by an end movement, a driving-shaft, and an upper portion to the case around such driving-shaft and adapted to being deflected with that shaft into an angular position to the case, a connection from the driving-shaft to the tool-holder for rotating the same, an internal spring surrounding a portion of the driving-shaft for causing the tool-holder to grasp the tool, and devices having opposing curved bearing-faces adapted to rock on one another and intervening between a portion of the driving-shaft and the spring for acting upon such spring to compress the same, and to simultaneously and positively move a portion of the driving-shaft longitudinally to remove the pressure on the tool-holder and permit the same to expand and release the tool when the shaft is deflected, substantially as set forth. 5th. The combination in a dental handpiece, of a case adapted to being grasped by the hand, a tool-holder to receive and grasp the tool by an end movement, a driving-shaft, and an upper portion to the case around such driving-shaft and adapted to being deflected with that shaft into an angular position to the case, a connection from the driving-shaft to the tool-holder for rotating the same, an internal spring surrounding a portion of the driving-shaft for causing the tool-holder to grasp the tool, and devices having opposing curved bearing-faces adapted to rock on one another and intervening between a portion of the driving-shaft and the spring for acting upon such spring to compress the same, and to simultaneously and positively move a portion of the driving-shaft longitudinally to remove the pressure on the tool-holder and permit the same to expand and release the tool when the shaft is deflected, and an adjustment between the tool-holder and the spring for varying the action and adapting the tool-holder to different sizes of tools, substantially as set forth. 6th. The combination in a dental handpiece, with the spring tool-holding jaws tapering at both ends of a sleeve receiving the spring tool-holder, an internal sleeve adjacent to the rear end of the spring tool-holder, a threaded adjusting stem within the internal sleeve, a thrust-piece against which the adjusting stem acts, the dental engine shaft and mechanism intervening between the thrust-piece and such shaft for applying or relieving the pressure upon the thrust piece, substantially as set forth. 7th. In a dental handpiece, the combination with the rigid case A and collar a¹,

having an internal rib, of the sleeve b¹, having a reduced end, the hard-metal collar b² at the end of the case A and sleeve b¹ and between the same and the rib of the collar a¹, substantially as set forth. 8th. In a dental handpiece, the combination with the sleeve b¹ and the rod h from the dental engine shaft, of the collar c¹, means for connecting the same to the rod h, the rod n, its head n¹ within the collar c¹ and a pin passing loosely through the head and into the collar c¹ to connect said parts, a head-block o around the rod n, the collar c¹ and head-block o having adjacent curved bearing faces whereby said rod h may be rocked or deflected from its axial line, and an end movement given to the rod n, substantially as set forth. 9th. In a dental handpiece, the combination with the sleeve b¹ and the rod h from the dental engine shaft, of the collar c¹ connected to said rod h and having an internal rib 11 and adjacent curved bearing faces 19 at one end thereof, the rod n screw-threaded at one end and the sleeve m upon said threaded end, the head n¹ having a flaring hole and adjacent neck and bearing within the collar c¹ against the rib 11, the pin 16 passing through said collar and head, the head-block o received within the end of the sleeve b¹ and having curved bearing-faces 18 that bear on the faces 19 and the helical expansion spring k around the rod n and acting against the sleeve m and inner end of the sleeve b¹ and block o to hold the faces 18 and 19 together tightly and the parts axially in line, substantially as set forth. 10th. In a dental handpiece, the combination with the sleeves b, b¹ and the spring tool-holder d¹, of the notched sleeves c¹ and m, the threaded adjusting-stem f within the sleeve c¹ and having a screw-driver notch 13, the rod n threaded at one end and screwing into the sleeve m, the thrust-piece r having reduced ends received within the notches of the sleeves c¹ and m and bearing at its ends upon the ends of the rod n and stem f respectively, the parts being adjusted longitudinally by the rotation of the stem f, by an instrument inserted in the room of the operating-tool, substantially as set forth. 11th. In a dental handpiece, the combination with the rigid case A, of the helical spring a, the collar a¹ having a threaded coupling 2 by which it is connected to the case A and an enlarged end recessed, the collar a² threaded at the back end and fitting within the spring a, the ends of the helical spring being permanently connected to the collars, and a tubular case l screwing at one end upon the collar a² and at the other end fitting within and bearing against the enlarged end of the collar a¹, and covering the spring a, substantially as and for the purposes set forth. 12th. In a dental handpiece, the combination with the sleeve b¹ and rod h from the dental engine shaft, of the collar c¹ having an internal rib 11 and adjacent curved bearing-faces 19 at one end thereof, the head-block o received within the end of the sleeve b¹ and having curved bearing-faces 18 bearing on the faces 19, the rod n, the head n¹ thereon and within the collar c¹ bearing upon the rib 11, a helical spring for drawing the parts into axial line, and means for connecting the head n¹ or rod h or both, to the collar c¹ to cause them to rotate together, substantially as set forth.

No. 58,474. Water Service Post. (*Boite de service en usage dans un système d'aqueduc.*)



Joseph Octave Alfred Laforest, Montréal, Québec, Canada, le 21 décembre 1897; 6 ans. (Déposé le 23 octobre 1897.)

Résumé.—1° La combinaison de la plaque ou support A en grès ou en tout autre terre cuite ou métal quelconque dans laquelle sont pratiqués les entailles T et S, et les creux B, C, B' et les ouvertures à mi-épaisseur D et D'; avec le tube E aussi en grès ou autre terre cuite, ayant les appendices d et d' qui s'emboîtent dans les ouvertures D et D'; et recouvert de la rondelle R en cuivre ou autre matière non oxydable, tel que décrit et pour les fins plus haut mentionnées. 2° La combinaison de la partie supérieure du tuyau en fer galvanisé, ou en toute autre substance non oxydable, formé des deux bouts F et H réunis par la bride N, avec l'anneau circulaire I en cuivre sur lequel se visse le couvercle ordinaire K, tel que décrit et pour les fins plus haut mentionnées.

No. 58,475. Axle-skein. (*Essieu.*)

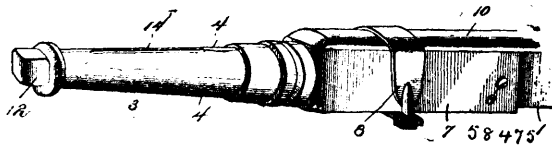

Evander M. Graham, assignee of Llewellyn R. Colwell, both of Ruston, Louisiana, U.S.A., 23rd December, 1897; 6 years. (Filed 1st December, 1897.)

Claim.—The combination of an axle having a reduced end 2, an axle-skein composed of two longitudinal sections arranged at

opposite sides of the axle, having inner tubular portions to receive the reduced end of the same, and provided beyond the axle with a solid outer portion, the terminals of the sections being reduced and exteriorly threaded, a transversely-disposed fastening device connecting the outer terminals of the sections, the straight parallel arms 7 formed integral with the sections and arranged on the front and rear faces of the axle, a fastening device passing through the ends of the arms and the axle, an axle-clip embracing the axle and securing the arms to the same, and an axle-nut arranged on the threaded terminals of the sections of the skein and concealing the ends of the adjacent fastening device, substantially as described.

No. 58,476. Swinging Gate. (Barrière tournante.)

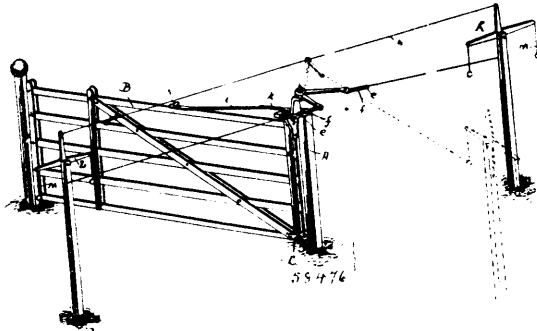

James A Jones, assignee of William H. Jones, both of Mount Cory, Ohio, U.S.A., 23rd December, 1897; 6 years. (Filed 2nd December, 1897.)

Claim.—1st. In a swinging gate of the character described, a shifting plate, arms for said plate adjustably secured thereto, and operating connections connected to said arms, substantially as and for the purpose described. 2nd. A shifting plate for swinging gates, comprising a plate adapted to shift the centre of gravity of the gate, operating arms therefor adapted to be adjusted relatively to the plate, and a clamping means for said arms, substantially as described. 3rd. In a swinging gate, the combination of hinges therefor, a shifting plate, and a connection between the shifting plate and the gate, said connection independent of the hinges, substantially as described. 4th. A shifting plate for gates comprising a plate having at its rear side an extension, arms carried by said extension, and a clamping means passing through the extension and the arms whereby the latter are adjustable in relation to the plate, substantially as described. 5th. In a swinging gate the combination of a shifting plate forming a hinge for the upper end of the gate, and a connection between the shifting plate and the gate, said connection being independent of the hinge of the gate, substantially as described. 6th. In a shifting gate, the combination of the gate a shifting plate forming the hinge for the upper end of the gate, and a link having one end pivotally connected with the shifting plate and its opposite end loosely connected with the gate to permit it a slight independent longitudinal movement in respect to the gate, substantially as described. 7th. In a swinging gate, the combination of the gate, a shifting plate therefor, a link having one end connected with the gate, and the other connected with the plate one end of link having a slot to permit it a longitudinal independent movement, substantially as described. 8th. In a swinging gate, the combination of the gate, a shifting plate therefor, and a connection loosely connected with the plate and the gate at a point between its ends, one end of the gate having a limited longitudinal movement independent of its connected member, substantially as described.

No. 58,477. Process of and Apparatus for Purifying and Decolorizing Saccharine, etc. (Procédé et appareil pour purifier et décolorer les liquides sacchariques, etc.)

The Electric Rectifying & Refining Co., Camden, New Jersey, assignee of Marshall Pridham, Philadelphia, Pennsylvania, both in the U.S.A., 23rd December, 1897; 6 years. (Filed 5th December, 1896.)

Claim.—1st. The herein described process of purifying saccharine and other liquids, which consists in subjecting the liquid to the action of an electric current and simultaneously passing ozone gas through the liquid, substantially as specified. 2nd. The herein described process of purifying saccharine and other liquids, which consists in subjecting the liquid in vacuo to the action of an electric current and simultaneously passing ozone gas through the liquid, substantially as specified. 3rd. The herein described process of purifying saccharine and other liquids, which consists in subjecting the liquid to the direct action of an electric current and simultaneously passing ozone gas through the liquid and subsequently subjecting the liquid so treated to further contact with ozone gas, substantially as specified. 4th. The herein described process of purifying saccharine and other liquids, which consists in subjecting the liquid while in a state of agitation, to the action of ozone gas, and simultaneously subjecting said liquid to the direct action of an

electric current, substantially as specified. 5th. The herein described process of purifying saccharine and other liquids, which

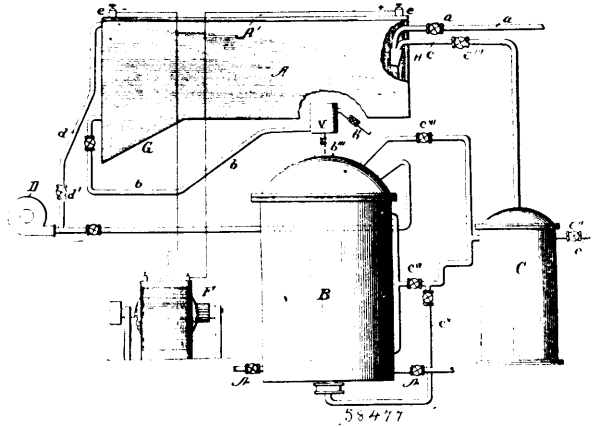

consists in first reducing the gravity of said liquid by the addition of water, and heating the same, and then subjecting the liquid so treated to the direct action of an electric current, and simultaneously passing ozone gas through the liquid, substantially as specified. 6th. The herein described process of purifying saccharine and other liquids, which consists in subjecting said liquid to the action of electrolytically developed aluminum hydrates and simultaneously passing ozone gas through the liquid, substantially as specified. 7th. The herein described process of purifying saccharine and other liquids, which consists in subjecting said liquid in vacuo to the action of electrolytically developed aluminum hydrates and simultaneously passing ozone gas through the liquid, substantially as specified. 8th. The herein described process of purifying saccharine and other liquids, which consists in subjecting said liquid to the action of electrolytically developed metallic decolorizing compounds, and simultaneously passing ozone gas through the liquid, substantially as specified. 9th. The herein described process of purifying saccharine and other liquids, which consists in subjecting said liquid in vacuo to the action of electrolytically developed metallic decolorizing compounds, and simultaneously passing ozone gas through the liquid, substantially as specified. 10th. The herein described process of purifying saccharine and other liquids, which consists in subjecting the liquid to the direct action of an electric current, and subsequently passing ozone gas through the liquid, substantially as specified. 11th. The herein described process of purifying saccharine and other liquids, which consists in subjecting the liquid in vacuo to the direct action of an electric current, and subsequently passing ozone gas through the liquid, substantially as specified. 12th. The herein described process of purifying saccharine and other liquids, which consists in subjecting the liquid to the direct action of an electric current and subsequently passing ozone gas through the liquid, while the same is in a state of agitation, substantially as specified. 13th. The herein described process of purifying saccharine and other liquids, which consists in first reducing the gravity of said liquid by the addition of water and heating the same, and then subjecting the liquid so treated to the direct action of an electric current, and subsequently passing ozone gas through the liquid, substantially as specified. 14th. The herein described process of purifying saccharine and other liquids, which consists in subjecting said liquid to the action of electrolytically developed aluminum hydrates and subsequently passing ozone gas through the liquid, substantially as specified. 15th. The herein described process of purifying saccharine and other liquids, which consists in subjecting said liquid in vacuo to the action of electrolytically developed aluminum hydrates, and subsequently passing ozone gas through the liquid, substantially as described. 16th. The herein described process of purifying saccharine and other liquids, which consists in subjecting said liquid to the action of electrolytically developed metallic decolorizing compounds, and subsequently passing ozone gas through the liquid, substantially as specified. 17th. The herein described process of treating saccharine and other liquids, which consists in subjecting said liquid in vacuo to the action of electrolytically developed metallic decolorizing compounds, and subsequently passing ozone gas through the liquid, substantially as specified. 18th. In an apparatus for purifying saccharine and other liquids, the combination of a tank for holding the liquid to be treated, plates forming positive and negative electrodes placed within the tank and connected to a suitable source of electricity, and collecting racks or their equivalents in the bottom of the tank for collecting the impurities precipitated from the liquid, substantially as described. 19th. In an apparatus for purifying saccharine and other liquids, the combination with the tank containing the liquid to be treated, of plates carrying a metallic decolorizing compound, forming positive electrodes and pitted or cellular plates forming negative electrodes, placed within the liquid in the tank, and electrical connections between said electrodes and a suitable source of electricity, substantially as

described. 20th. In an apparatus for purifying saccharine and other liquids, the combination with the tank containing the liquid to be treated, of plates carrying a metallic decolorizing compound forming positive electrodes, plates having openings, pits or cells, adapted to receive the electrolytically developed metallic compound after it has passed from the positive electrodes through the liquid, and collecting devices in the bottom of the tank for collecting the precipitated impurities, substantially as described. 21st. In an apparatus for purifying saccharine and other liquids, the combination with a tank containing the liquid to be treated, of an ozone reservoir connected to said tank, and an air exhauster connected with said tank, electrodes within the tank connected to a suitable source of electricity, whereby the liquid may be subjected to the action of an electric current in vacuo, and a secondary tank having connections with the ozone reservoir and air exhauster, and a discharge pipe leading from the first tank to the second tank, whereby the liquid after treatment in the first tank may be subjected to the action of ozone in vacuo, in the secondary tank, substantially as described. 22nd. In an apparatus for purifying saccharine and other liquids, the combination with a main tank containing the liquid to be treated, means for subjecting said liquid to electrolytic treatment, and a secondary tank provided with connections to the main tank, an ozone reservoir and an exhaust apparatus connected to the said secondary tank and spraying device in said tank located in line with the inlet for ozone and liquid to said tank, substantially as described. 23rd. In an apparatus for purifying saccharine and other liquids, the combination with a main tank containing liquid to be treated, means for subjecting said liquid to the action of an electric current in vacuo, a secondary tank provided with connections to an ozone generator and air exhauster, and a spraying device in said latter tank located in line with the inlet of ozone and liquid thereto, whereby the liquid may be introduced in said tank in a finely divided state, and intimately mixed with the ozone gas, substantially as described. 24th. In an apparatus for purifying saccharine and other liquids, the combination with a main tank containing liquid to be treated, means for subjecting said liquid to the action of an electric current, and means for subjecting said liquid to the action of ozone gas in vacuo, of a secondary tank provided with connections to an ozone reservoir and air exhauster, and a spraying device located in said tank in line with the liquid inlet to said tank, substantially as described. 25th. In an apparatus for purifying saccharine and other liquids, the combination with a main tank containing the liquid to be treated, and means for subjecting said liquid to electrolytic action, of a secondary tank provided with connections to an ozone reservoir, and an exhauster, a pipe leading from the main tank to secondary tank, and a mechanical agitator in said secondary tank for agitating the liquid, substantially as described. 26th. In an apparatus for purifying saccharine and other liquids, the combination with a tank for holding the liquid, of an inlet pipe for the liquid, a pipe adapted to connect to an air exhauster, a supply pipe adapted to be connected to an ozone reservoir, a mechanically operated agitator in the bottom of said tank, perforated pipes carried by and moving with said agitator and connected with the ozone supply pipe, substantially as described. 27th. In an apparatus for purifying saccharine and other liquids, the combination in a tank for holding the liquid for treatment, of an inlet pipe for the liquid, perforated pipes within the tank, a pipe connecting said perforated pipes with a supply of ozone gas, a horizontal agitator rotatably mounted above the bottom of the tank, and a perforated pipe carried by said agitator and connected to the ozone supply, substantially as described. 28th. In an apparatus for purifying saccharine and other liquids, the combination with a tank for holding the liquid to be treated, of an inlet pipe for the liquid, a spraying device in line with said inlet pipe, a pipe leading from a supply of ozone gas into the top of the tank, and discharging near the liquid inlet, a series of perforated pipes disposed vertically within the tank and connected with the ozone gas supply, substantially as described. 29th. In an apparatus for purifying liquids, the combination in a tank for holding the liquid to be treated, of an inlet pipe for the liquid, a spraying device in said tank in line with said inlet, a pipe leading from an ozone gas supply into the top of the tank near the liquid inlet, a series of perforated pipes vertically disposed within the tank, an agitator rotatably mounted above the bottom of the tank, substantially as described. 30th. In an apparatus for purifying saccharine and other liquids, the combination with a tank for holding the liquid to be treated, of an inlet for the liquid, a spraying device in said tank in line with the inlet, an ozone gas supply pipe leading into the top of the tank near said inlet, a series of perforated pipes vertically disposed within the tank and connected with the ozone gas supply, an agitator rotatably mounted above the bottom of the tank and carrying a perforated pipe communication with the ozone gas supply, substantially as described. 31st. In an apparatus for purifying saccharine and other liquids, the combination with a tank for holding the liquid to be treated, of an inlet pipe for the liquid, an agitator consisting of a hollow hub rotatably mounted above the bottom of the tank, and vanes extending from said hub, a pipe communicating with the bottom of said hub and connected to an ozone gas supply, and a perforated pipe carried by the vanes of said hub and communicating therewith, substantially as described. 32nd. In an apparatus for purifying saccharine and other liquids, the combination with the main tank containing the liquid to be treated and means for electrolytically treating said

liquid therein, of a tank located below the main tank, connections between said tank and an air exhauster and an ozone gas supply, a reservoir interposed between the two tanks and connected with the discharge of said main tank, and a spraying device in the top of the secondary tank, and a pipe leading from said reservoir through the top of the secondary tank to said spraying device, substantially as described. 33rd. In an apparatus for purifying saccharine and other liquids, the combination of a main tank containing the liquid to be treated, means for treating said liquid by electrolytic action, with a tank located below the main tank, a reservoir between the two tanks and connected with the discharge of the main tank, a pipe leading into said reservoir above the liquid level thereof and connected to a source of air pressure, a spraying device in the top of the tank, and a pipe leading from the reservoir to the spraying device, substantially as described.

No. 58,478. Cutting Device. (Hachour.)

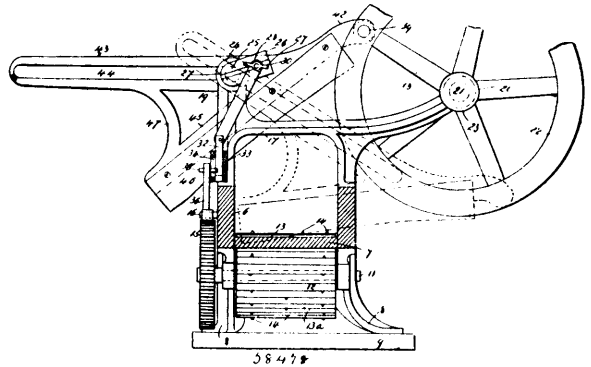

Mary Bailey Hall, assignee of Julius Carleton Hall, both of Wallingford, Connecticut, U.S.A., 23rd December, 1897; 6 years. (Filed 4th October, 1897.)

Claim.—1st. A chopping machine comprising an oblong box or casing which is open at one end, and provided with suitable supports, said box or casing being also provided at one end with a frame which is projected above the same, and which is provided at one side with a laterally projecting arm, and at the other side with an upwardly directed extension, a wheel supported by said arm, provided with a crank rod, and a rectangular frame connected with said crank rod, and the upper portion of which consists of a bar in which is formed a longitudinal slot, and the lower portion thereof being provided with a cutting blade, a shaft mounted in said upwardly directed portion of the frame, and passing through the slot in the triangular frame, and on one end of which is an oblong head, and said frame being provided with a feed roller which is mounted below the end of the box or casing, and which projects upwardly through the bottom thereof, a ratchet wheel mounted on the shaft of said feed roller, at one side of the box or casing, said ratchet wheel and said oblong head being in operative connection, substantially as shown and described. 2nd. A chopping machine consisting of an oblong box or casing which is open at one end, and suitably supported, said box or casing being also provided at the open end with a frame which is projected upwardly, and provided at one side with an arm, and at the opposite side with an upwardly directed extension, a wheel supported by said arm and provided at one side with a crank rod, a triangular frame connected with said crank rod and provided at the lower side thereof with a cutting blade, and at the upper side thereof with a longitudinal slot, a shaft mounted in the upper end of said extension of the frame and projecting through said slot and provided at one end with an oblong head, a feed roller mounted below the box or casing and projecting upwardly through the bottom thereof, a ratchet wheel mounted on one end of the shaft of said feed roller, a rod connected with the oblong head of the shaft which passes through the slot in the triangular frame, a bar connected with the lower end of said rod and vertically movable in a keeper secured to said frame, and a pawl pivotally connected with said rod and adapted to operate in connection with said ratchet wheel, substantially as shown and described. 3rd. A chopping machine comprising an oblong box or casing which is open at one end, and a feed roller mounted beneath the open end of said box or casing and projecting upwardly through the bottom thereof, a frame connected with said end of said box or casing and provided at one side with an arm, and at the opposite side with an upwardly directed extension, a wheel supported by said arm and provided at one side with a crank rod, a triangular frame connected with said wheel and provided at its upper side with a longitudinal slot, and at its lower side with a cutting blade, a shaft passing through said slot and through the upwardly directed extension of the frame, and provided at one end with an oblong head, and operative devices connecting said head and said feed roller whereby the latter is given an intermittent motion, substantially as shown and described.

No. 58,479. Cash Registering Machine.
(Régistre de monnaie.)

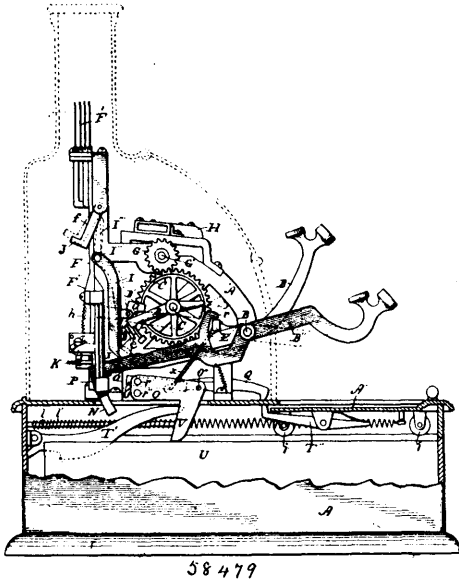

Laurence Cooney, M. Henry Lane, Frank B. Lay, Horace B. Peck and Hale P. Kauffer, all of Kalamazoo, Michigan, U.S.A., 23rd December, 1897; 6 years. (Filed 16th August, 1897.)

Claim.—1st. In a cash register, the combination of the base A, carrying the frame A¹, above keys B¹, pivoted on shaft B, towards the front part of said frame A¹, and having downwardly projecting timo trailers N, to the rear guided between suitable upright bars B², and having racks on the said downwardly projecting trailers, a pivoted bar K, to the rear of each set of said keys acting as a reversible pawl to compel the complete revolution of any key started, wedge shaped bodies P, pivoted on said bars B², and retained by the hook lugs P¹, which limit the motion thereof to the width of a single key for arresting all of the remaining keys when any key is struck up, the indicator slides F, corresponding to said keys and above the same bearing indicator tablets F¹, at the top and having catches F¹¹, on their back side, detaining bars J, J¹, J¹¹, for each section of said keys, lugs J¹¹, J¹¹¹, on the bars J¹, J¹¹, projecting to the rear of the bar J, a transverse union bar E, pivoted on shaft B, and extending across all of the keys of said machine, a key B¹¹, called the "union key," connected by a suitable hook to the bar E, to actuate the union key whenever any register key is operated, a lever I pivoted in the casing A¹, with a cam lug I¹, at the lower end thereof, a cam lug a, on the union key B¹¹, for striking said lug I¹, when the union key is raised to operate the lever I, to throw out the central detaining bar J, to release all of the indicator slides that are up, a rack on a downwardly depending trailer to the rear of the key B¹¹, an independent reversible pawl K¹, for detaining the said union key in the elevated position until it has completed its stroke when it returns to its initial position, a drawer U, in the base A, a hooked lever T¹, projecting upwardly and forwardly to retain said drawer, a cover A¹¹, to said drawer carried on suitable rollers, a catch T¹¹, to said cover A¹¹, for engaging a hole in the top of the said base A, a lever Q, pivoted above the top of said base in position to strike the detaining catch of the drawer, a link x, connecting said lever to the union bar E, to actuate said lever when any registering key is operated, an angular lever O, V, pivoted at O¹¹, above the drawer cover, one end of which projects downwardly across the path of said cover, the other portion of which projects under the union key with the pin r¹, for engaging the same so that when the drawer cover opens the lever will operate and throw the union key to its highest position so that it will fall when the drawer cover is pulled to its first or normal position; gear wheels C¹, pivoted above and in front of the shaft B, on the shaft C, through the frame A¹, arms M, M, pivoted on said shaft or rod C, standing at angles to each other, transverse gradient bar M¹, connecting the rear ends of the arms M, and stop bars M¹¹, connecting the front end of the arms M, the dog S on the gradient bar M¹, the spring S¹, for holding it out of engagement with the gear wheel C¹, a sliding bar t, with lugs or ears r¹, at each end thereof and downwardly projecting cam shaped hook portions t¹ below supported on rollers r¹¹, through slots therein, the bar r¹¹, to the rear for retaining said bar t, in position; shouldered projections u¹, on the rear of each of said keys beyond a bevelled portion to engage the cam hooks t¹; pawls c, c, on said frame A¹, to engage the ears r¹, on the bar t, pinions actuated from teeth on the face of gear C¹, and an adder in case H, actuated from said pinions, all substantially as described and co-acting together for the purpose specified. 2nd. In a cash register, the combination of a group of register keys B¹, pivoted toward the

front of said machine with downwardly depending trailer portions N to the rear of said keys with racks formed thereon, a transverse flat horizontal pivoted bar K, extending across the rear of the group of said keys positioned to engage the racks on the trailer portion of said keys, upwardly projecting ears at the end of said bar, springs attached to said ears and to the frame above to put tension upon the bar and retain it normally in the horizontal position so that the bar shall form a universal reversible pawl for the key of the group which shall reverse automatically on the completion of the stroke of the keys for the controlling the action of each of said keys as specified. 3rd. In a cash register, the combination of a group of register keys B¹, with downwardly projecting trailer portions N, to the rear end thereof guided between suitable upright bars B², wedge shaped bodies P, forked at the top and of a width at that point equal to the width of a key plus the width of a guide bar B², supported point downward on said upright bars and secured in position by the hook lugs P¹, between the fork at the top to arrest the remaining keys of each section when any key is struck up for the purpose specified. 4th. In a cash register, the combination of pivoted register keys in groups or divisions, a common bar E, pivoted by lateral arms and extending across all of the keys of all of the sections, a union key B¹¹, connected to said bar E by a suitable hook, indicator slides corresponding in number to the register keys, situated above the same to be actuated thereby; indicator tablets situated at the top of said indicator slides, catches F¹¹, to the rear of said indicator slides, bar J, J¹, J¹¹, for each division of the machine suspended to the back of the indicator slides of each group, the bar J being within the bars J¹, J¹¹, projecting ears J¹¹, J¹¹¹, from the bar J¹, J¹¹, out back of the bar J, and at a little distance therefrom, a lever I, pivoted in the casing of said machine in position to act upon the central bar J, and throw it out, a cam lug I¹, at the lower end of said lever I, a cam lug a¹, on the union key B¹¹, when the union key is actuated, a downwardly projecting trailer portion on the union key with a suitable rock thereon, and reversible pawl K¹, in position to engage the rack and retain the union key in the elevated position until it is raised to the end of its stroke, beyond the stroke of the register keys, all co-acting together substantially as described. 5th. In a cash register, the combination of pivoted keys, common bar E, extending across said keys, a union key B¹¹ connected to said bar E by suitable means, indicator slides corresponding to said keys and adapted to be raised thereby, a detaining bar for said indicator slides, a lever I, pivoted in the casing of said machine in position to act upon the detaining bars, cam lug I¹ on the lower end of said lever, cam lug a¹, on the union key in position to act upon the cam lug I¹, when the union key is actuated, a rack on said union key and a reversible pawl for acting upon the same for detaining said key, all co-acting as specified. 6th. In a cash register, the combination of suitable registering keys, an independent union key connected by suitable means to be actuated when any register key is operated, indicator slides to be raised by said register keys, a detaining bar for said indicator slides, a lever pivoted in the casing of said machine to act upon the detaining bar, a cam lug on said lever, and a cam lug on said union key in position to act upon the cam lug of the lever and to pass the same to move the detaining bar to release the indicator slides whenever a key is actuated for the purpose specified. 7th. In a cash register, the combination of suitable register keys, an independent union key connected by suitable means to be actuated when any register key is to be actuated for a new registration, indicator slides to be raised by said register keys, a detaining bar for said indicator slides, and suitable connections from said detaining bar to the independent union key so that when the independent union key is actuated the detaining bar will be moved and release the indicator slides for the purpose specified. 8th. In a cash register made up of suitable register keys in sections or divisions, the combination of indicator detaining devices for each section of indicator slides, ears projecting from each sectional detaining device over the central section and at a little distance therefrom, a lever pivoted in the frame of each machine in position to act upon the central detaining bar, a suitable independent union key to act upon said lever when any register key is actuated, and means connected with the drawer mechanism for holding said union key in an inoperative position until the drawer is closed for the purpose specified. 9th. In a cash register made up of sections or divisions, the combination of suitable register keys for each section, indicator slides for each section, separate detaining bars for each section of indicator slides, one of said bars being inside of the rest, ears projecting from the outer detaining bars over the inner detaining bars at a little distance therefrom, a suitable trip mechanism connected with registering keys for throwing out the inner detaining bar whenever a key of the register is operated, and connections with the drawer for holding said tripping mechanism inoperative when the drawer is open as specified. 10th. In a cash register made up of sections or divisions, the combination of suitable register keys for each section, indicator slides for each section, separate detaining bars for each section of indicator slides, one of said bars being inside of the rest, ears or projections from the outer detaining bars over the inner detaining bars and at a little distance therefrom, a suitable tripping mechanism independent of said bars for tripping the inner detaining bar at the beginning of each registration so that an indicator slide can be struck up in each and any section at each registration without disturbing the indicator slides of the other sections which have been struck up during the registration as specified. 11th. In a cash register, the combination of the base A, the

drawer U therein, forwardly and upwardly projecting hook lever T¹, to engage the back of said drawer, the cover A¹¹, for the forward portion of the drawer riding on suitable rollers, forwardly projecting rods Z, from the rear of said base, coiled springs U, supported thereby and connected to downwardly projecting pins on the underside of said cover A¹¹, a catch lever T¹¹, pivoted to the underside of said cover and adapted to engage in a hole in the top of the base A, lever Q pivoted above the top of the base with a downwardly projecting point to trip the catch of the drawer cover, the common bar E across all of the keys above, and a suitable link connecting said lever Q to the common bar E, so that on the depression of any key the drawer cover will be released and move back and uncover and unlock the drawer U, all substantially as described for the purpose specified. 12th. In a cash register, the combination of the base A, with a drawer therein, cover A¹¹, for the drawer riding on suitable rollers, a spring connection for said cover, a catch pivoted on said cover to engage in the top of said base and retain said cover in a closed position, a lever above with a downwardly projecting part to trip the catch on said cover, and connections from said lever to the keys above, all co-acting together for the purpose specified. 13th. In a cash register, the combination of a suitable base, a money drawer in said base, a hook lever pivoted to the rear of said base in position to engage the back of said money drawer and projecting upwardly across the path of the cover so that when the cover is opened the drawer will be released and can be drawn out if necessary, as specified. 14th. In a cash register, the combination of the base A, with a drawer therein; sliding cover for said drawer with means to open it when released by the action of the keys, a union key B¹¹, actuated from the register keys for releasing the indicator slides of the machine, a bent lever O V, composed of parts pivoted above the path of said drawer cover, the part V, projecting across the path of said drawer cover, a pin r¹, on part O, to engage under the union key B¹¹, so that when the drawer comes open the lever will hold the union key in the elevated position, for the purpose specified. 15th. In a cash register, the combination of a money till, a cover for said till, an independent union key connected to the register keys of the machine to be actuated thereby and release the indicator slides, and connections from said cover to said union key to hold the same in an inoperative position when the drawer is opened for the purpose specified. 16th. In a cash register, the combination of register, keys an independent union key connected therewith to be actuated by any one of them a part of its stroke, connections from said union key to a trip mechanism for releasing the indicator slides, a reversible pawl for retaining said union key in its operated position so that it shall be inoperative until the pawl is released by completing its stroke for the purpose specified. 17th. In a cash register, the combination of pivoted register keys B¹, supported on a shaft B, a shaft C, parallel with said shaft B, and in the rear of and above the same, gear wheel C¹, on the said shaft C, with suitable connections to numbering wheels, arms, M, M, supported at an angle to each other on shaft C, gradient bar M¹, supported on the rear ends of said arms transverse to said keys and in position to be actuated different distances by each of said keys, a dog attached to said bar for engaging the gear wheel C, an angled stop bar M¹¹, on the front end of said arms M, to strike against the keys in front of said shaft C, to stop the motion of the same and prevent over-registration, as specified. 18th. In a cash register, the combination of pivoted register keys B¹, on shaft B, which is toward the front of said machine, the shaft C, in the rear of said shaft B, gear wheel C¹, on said shaft C, arms M, supported on shaft C, at angles to each other, gradient bar M¹, supported on the rear ends of said arms M, in position to be actuated different distances by the different register keys, a stop bar M¹¹, on the front ends of said bars M, to strike against the keys when they complete their stroke, a dog S, pivoted on arm M, in position to engage the gear wheel C¹, a spring S¹, tending to throw dog S, out of engagement, sliding bar t, supported on rollers r¹¹¹, on gradient bar M¹, in position to strike the dog S, and throw it into engagement with the gear C¹, bearing lugs v¹, r¹, bar r¹¹, for retaining said bar t, in position, downwardly t, projecting cam shaped hooks t¹, t¹, on the bar t, corresponding in number to the register keys, shouldered lugs u¹, on said register keys in position to engage in the hooks t¹, when a key is struck up and carry the bar to one side, and dogs c¹, supported on the frame of said machine to engage over the lugs v¹, to hold the register mechanism locked until actuated by a key, all co-acting together, substantially as described for the purpose specified. 19th. In a cash register, the combination of pivoted register keys toward the front of said machine, gear wheel C¹, supported on a suitable shaft, suitable number wheels in position to be actuated by said gear wheels, arms M, M, on said gear wheel shaft, standing at angles to each other; gradient bar supported on said arms in position to be actuated different distances by the different register keys, downwardly projecting hook portions on said gradient bar to engage the keys when they are struck against it to control the actuation of the keys and gradient bar together, for the purpose specified. 20th. In a cash register, the combination of pivoted register keys toward the front of said machine gear wheels C¹, supported on a suitable shaft, suitable number wheels in position to be actuated by said gear wheel, arms M, M, on said gear wheel shaft standing at angles to each other, gradient bar supported on said arms in position to be actuated different distances by the different register keys, a sliding bar on said gradient bar connected to be moved by the actuation of any key, a dog connected to said bar to engage said gear wheel for

the purpose specified. 21st. In a cash register, the combination of pivoted register keys toward the front of said machine, gear wheel C¹, supported on a suitable shaft, suitable number wheels in position to be actuated by said gear wheels, arms M, M, on said gear wheel shaft, standing at angles to each other, gradient bar supported on said arms in position to be actuated different distances by the different register keys, a sliding bar on said gradient bar connected to be moved by the actuation of any key, cam hooks on said bar, a dog connected to said sliding bar in position to engage said gear wheel, and a spring to throw said dog out of engagement for the purpose specified. 22nd. In a cash register, the combination of pivoted register keys toward the front of said machine, gear wheel C¹, supported on a suitable shaft, suitable number wheels in position to be actuated by said gear wheels, arms M, M, on said gear wheel shaft, standing at angles to each other, a gradient bar supported on said arms in position to be actuated different distances by the different register keys, a sliding bar on said gradient bar connected to be moved by the actuation of any key, cam hooks on said bar, a dog connected to said sliding bar in position to engage said gear wheel and a spring to throw said dog out of engagement, a projection on said sliding bar, and a pawl or dog to engage it to lock the same after any registration for the purpose specified. 23rd. In a cash register, the combination of pivoted register keys toward the front of said machine, gear wheel C¹, supported on a suitable shaft, suitable number wheels in position to be actuated by said gear wheel arms M, M, on said gear wheel shaft, standing at angles to each other, gradient bar supported on said arms in position to be actuated different distances by the different register keys, a sliding bar on said gradient bar connected to move by the actuation of any key, cam hooks on said bar, a dog connected to said sliding bar in position to engage said gear wheel, and a spring to throw said dog out of engagement, a pawl to engage said sliding bar to lock the same after registration for the purpose specified. 24th. In a cash register, the combination of register keys, a gradient bar to be actuated by said keys a movable bar on said gradient bar in position to be operated by said key, a dog connected to said movable bar to engage the register wheels positively, co-acting as specified. 25th. In a cash register, the combination of register keys, a gradient bar in position to be acted on by said keys, hooks carried by said bar to engage said keys and compel an action of both together, for the purpose specified. 26th. In a cash register, the combination of register keys, a gradient bar in position to be actuated by said keys, catches carried by said bar to engage any key coming in contact therewith to compel the operation of both together, a register mechanism connected to said bar for the purpose specified. 27th. In a cash register, the combination of register keys, a register mechanism, a pawl to prevent the return of said mechanism, a gradient bar with a bar thereon to engage positively the register mechanism, catches on said gradient bar to engage the register keys and lock them severally to said bar whenever one is operated, and suitable stops for said keys to prevent the operation of more than one at a time, as specified. 28th. In a cash register, the combination with a suitable base, of the frame A¹, and the shaft B, toward the front thereof, register keys in sections or divisions pivoted on said shaft and projecting to the rear of the machine, trailers N, with racks thereon, the common reversible pawl extending across said trailers to compel the complete operation of each key, key arrester bodies P, P, for each section to prevent the operation of but a single key, downwardly extending pivoted bodies R, R, between the sections of arrester bodies for transferring the motion from one set of keys to the other so that but a single key of the entire machine can be operated at a time, indicator tablets P¹, indicator slides F for supporting the same, sustaining bars J¹, J¹, J¹, for said indicator slides lapping over each other at a little distance apart, so that they may be operated independently, a union key B¹¹, actuated by suitable connections with the register keys of the machine to operate a trip lever to release the indicator slides and let the tablets fall at each registration, a register mechanism consisting of a train of number wheels the three lower wheels of which correspond to the divisions of the machine and positioned to be actuated independently from the gradient bar of each division by suitable gear connections therefrom, a spring pawl on the second number, gear wheel in position to actuate the third and allow the independent forward movement of the third, a dog W¹, to engage the third wheel in position to be tripped by the second wheel, to prevent over registration of the third, a detaining dog g¹¹, for locking the second wheel, a pin g¹, on the first wheel to actuate said dog to prevent over registration of the second wheel when the first wheel is operated, all co-acting together substantially as described for the purpose specified. 29th. In a cash register, the combination of a supporting frame, groups for sections of register keys, the groups corresponding to the denominations of money, an indicator tablet for each key in groups corresponding to the groups of keys, indicator sustaining devices for each group of keys, adapted to operate independently, suitable key arresters to prevent the operation of more than one register key in the entire machine at a time, a lever connected to be actuated by any of said register keys to trip all of the tablet sustaining devices at the beginning of a registration, a total register mechanism and a transfer mechanism for transferring the amount registered by each key to the total register, as specified. 30th. In a cash register, the combination of the indicator tablet slides F, and register keys in groups for actuating the same, key arresters P, for preventing the operation of

more than one key at a time in each group, and bodies R, R, pivoted to the casing to transfer the motion from one group of key arresters to the remaining groups to prevent the operation of more than one register key at a time on the entire machine. 31st. In a cash register, the combination of the indicator tablet slides F, keys B¹, for actuating the same, key arresters P, for preventing the operation of more than one key at a time in each group, and an intervening body to transfer the motion from one group of key arresters to the remaining groups to prevent the operation of more than one register key at a time on the entire machine. 32nd. In a cash register, the combination of a train of number wheels s, j¹, m¹ and w¹, in train successively, independent connections from the number wheels to actuate the same independently, a lock lever g¹¹, pivoted at g¹¹¹, to lock the wheels j¹, a pin g¹, for actuating the lever g¹¹, to lock the wheel j¹ whenever it is moved one step by the wheel s, a spring pawl j¹¹, connected to the wheel j¹, to actuate the wheel m¹, one step at each revolution of the wheel h, and permit the wheel m¹ to revolve past it in the same direction, a shaft m, carrying wheel m¹, an additional gear-wheel m¹¹ on said shaft m, a guided bar W, carrying the dog W¹, to engage the gear m¹¹, a tooth y on the shaft j, of the gear-wheel j¹, positioned to actuate the bar W, by striking a lug y¹ thereon to throw the dog W¹ into the gear-wheel m¹¹, to prevent over-registration, and a spring b, to hold the dog W¹, normally out of engagement, all co-acting together for the purpose specified. 33rd. In a cash register, the combination of number wheels s, j¹, m¹, and w¹, in train, suitable cogs, lugs or pawls on each side of said number wheels meshing directly with the next higher wheel in the train to actuate the next higher number wheel, a locking lever extending between the number wheels s and j¹, to lock the wheel j¹, when it is moved one step from the action of wheel s, the dog W¹, actuated from the wheel j¹, to lock or stop the wheel m¹, when it is moved one step by the wheel j¹, as specified. 34th. In a cash register, the combination of number wheels s, j¹, and m¹ and w¹ in train, suitable gear connections on each of said number wheels meshing with the next higher, pin or pins g¹, on the side of number wheel s, corresponding to the actuating cog or cogs thereon, a stop lever g¹¹, pivoted at g¹¹¹, between wheels s and j¹, with one end in a plane to engage with the teeth of number wheel j¹, and the other end off-set to contact with a pin g¹, to be actuated thereby only when the wheel s actuates wheel j¹, so that the wheel s in actuating wheel j¹, also operates lever g¹¹, to lock the wheel j¹, as soon as one space is moved, and prevent inaccuracy, as specified. 35th. In a cash register, the combination of number wheels j¹, m¹ and w¹ in train, supported in a suitable frame, suitable ratchet connections between said wheels j¹, and m¹, to permit the operation of the higher wheels independent of the lower, an axle j, for wheel j¹, a slide W, across said frame in close proximity to the axle j, of wheel j¹, a lug y¹, on said slide, a dog W¹, on slide W, to serve as a stop to wheel m¹, a lug y, on axle j, positioned to actuate slide W, to stop wheel m¹, at each step of its actuation, a spring b, to hold the dog W¹, normally out of engagement, as specified.

No. 58,480. Perpetual Date Calendar Applicable to Pencil Cases, Pens, etc. (Calendrier pour crayons, etc.)

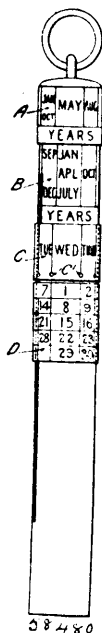

James Sinclair Heithersay, Stirling Terrace, Albany, assignee of James Tongham Draper, Pingelly, both in Australia, 23rd December, 1897; 6 years. (Filed 21st April, 1897.)

Claim.—1st. In combination (a) a pencil-case, pen, walking-stick or similar cylindrical article on a suitable part of which are displayed the names of the months arranged in the relative positions shown for ordinary and leap years, (b) a cylindrical surface on which are displayed the names of the days of the week, such cylindrical surface being capable of revolution upon the article as desired, and (c) a cylindrical surface on which are displayed the numbers of the days of the month, such cylindrical surface being capable of revolution upon the article, all substantially as described and for the purposes set forth. 2nd. In a date calendar, a pencil-case, pen, walking-stick, or similar cylindrical article on a suitable part of which are displayed as shown, the names of the months for ordinary and leap years, a cylindrical surface on which are displayed the names of the days of the week, such cylindrical surface being capable of revolution upon the article as desired, and a cylindrical surface on which are displayed the numbers of the days of the month, such cylindrical surface being capable of revolution upon the article, and a spring catch adapted to engage holes in the days of the week cylinder, substantially as described and for the purpose set forth.

No. 58,481. Chemical Engine. (Machine chimique.)

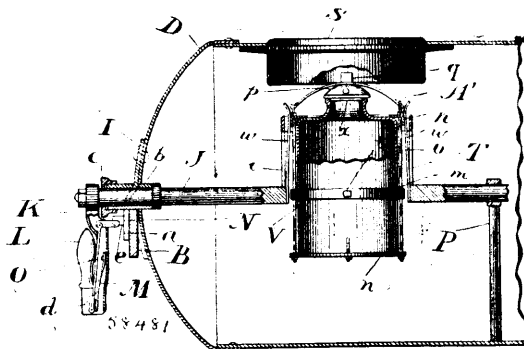

Thomas Down and James Jeffrey, both of Toronto, Ontario, Canada, 23rd December, 1897; 6 years. (Filed 1st September, 1897.)

Claim.—1st. In a chemical engine, a stationary cylinder provided with a discharge outlet and a recharging opening closed by a suitable plug, in combination with a suitably journaled rotatable shaft extending through one end of the cylinder, and acid bottle supported by the said shaft so that the rotation of the shaft will reverse the acid bottle and discharge its contents, arms rigidly connected to the said shaft, and a chain connecting the said arms, substantially as and for the purpose specified. 2nd. In a chemical engine, a stationary cylinder provided with a discharge outlet and a recharging opening closed by a suitable plug, in combination with a suitably journaled rotatable shaft extending through one end of the cylinder, arms rigidly connected to the said shaft, and a chain connecting the said arms, substantially as and for the purpose specified. 3rd. In a chemical engine, a stationary cylinder provided with a discharge outlet and a recharging opening of sufficient size to admit an acid bottle and closed by a suitable plug, in combination with a suitably journaled shaft extending through one end of the cylinder, a cage carried by the shaft, and an acid bottle removably supported within the cage, so that the rotation of the shaft will reverse the acid bottle and discharge its contents, substantially as and for the purpose specified. 4th. In a chemical engine, a stationary cylinder provided with a discharge outlet and a recharging opening closed by a suitable plug, in combination with a suitably journaled divided shaft, the contiguous ends of which have each a half cage formed thereon adapted to form, when bolted together, a support for a removable acid bottle which may be readily engaged with and disengaged from the acid bottle, substantially as and for the purpose specified. 5th. In a chemical engine, a stationary cylinder provided with a discharge outlet and a recharging opening closed by a suitable plug, in combination with a suitably journaled divided shaft, the contiguous ends of which have each a half cage formed thereon, adapted to form, when bolted together, a support for an acid bottle, arms rigidly connected to the said shaft, and a chain connecting the said arms, substantially as and for the purpose specified. 6th. In a chemical engine, a stationary cylinder provided with a discharge outlet and a recharging opening closed by a suitable plug, in combination with a suitably journaled rotatable shaft extending through one end of the cylinder, an acid bottle enclosed in a skeleton jacket provided with one or more lugs, and a cage supported by the said shaft and recessed to receive and support the said lugs, substantially as and for the purpose specified. 7th. In a chemical engine, a stationary cylinder provided with a discharge outlet and a recharging opening closed by a suitable plug, in combination with a suitably journaled rotatable shaft extending through one end of the cylinder, an acid bottle enclosed in a skeleton jacket provided with one or more lugs, and a cage supported by the said shaft and recessed to receive and support the said lugs, a spring-catch connected to the case and adapted to engage the jacket of the acid bottle to retain it

in the cage, substantially as and for the purpose specified. 8th. In a chemical engine, a stationary cylinder provided with a discharge outlet and a recharging opening closed by a suitable plug, in combination with a suitably journaled rotatable shaft extending through one end of the cylinder, an acid bottle enclosed in a skeleton jacket provided with one or more lugs, a cage supported by the said shaft and recessed to receive and support the said lugs, a spring-catch connected to the cage and adapted to engage the jacket of the acid bottle to retain it in the cage, a cap for the bottle, a bail pivoted to the jacket and adapted to retain the cap in position, and a projection upon the cylinder with which the bail will engage when the shaft is rotated, substantially as and for the purpose specified. 9th. In a chemical engine, a stationary cylinder provided with a discharge outlet and a recharging opening closed by a suitable plug, in combination with a suitably journaled rotatable shaft extending through one end of the cylinder, an acid bottle enclosed in a skeleton jacket provided with one or more lugs, a cage supported by the said shaft and recessed to receive and support the said lugs, a spring-catch connected to the cage and adapted to engage the jacket of the acid bottle to retain it in the cage, a cap for the bottle, provided with a tit to one side of the centre, a bail pivoted to the jacket and adapted to retain the cap in position, and a projection upon the cylinder with which the bail will engage when the shaft is rotated, substantially as and for the purpose specified. 10th. In a chemical engine, a stationary cylinder provided with a discharge outlet and a recharging opening closed by a suitable plug, in combination with a suitably journaled rotatable shaft extending through one end of the cylinder, an acid bottle suitably supported by the said shaft, a cap for the said bottle, a pivoted bail adapted to retain the cap in position, and a projection upon the cylinder with which the bail will engage when the shaft is rotated, substantially as and for the purpose specified. 11th. In a chemical engine, the combination of the frame A, pillow stays B, and bearing plates I, provided with flanges a, secured to the pillow stays, substantially as and for the purpose specified. 12th. In a chemical engine, the combination of the frame A, pillow stays B, bearing plates I, provided with flanges a secured to the pillow stays, sleeve b, extending through one bearing plate, a suitably journaled shaft J, extending through said sleeve, and the handle K, substantially as and for the purpose specified. 13th. In a chemical engine, the combination of the frame A, pillow stays B, bearing plates I, provided with flanges a, secured to the pillow stays, the extension L, pivoted on the said handle, the latch N, centrally pivoted on said handle, the pitman O, pivotally connecting with the latch N, and extension L, and the lugs c, upon the plate I, with which the said latch engages, substantially as and for the purpose specified. 14th. In a chemical engine, the combination of the frame A, pillow stays B, bearing plates I, provided with flanges a, secured to the pillow stays, the extension L, pivoted on the said handle, the latch N, centrally pivoted on said handle, the pitman O, pivotally connecting the latch N, and extension L, the lugs c, upon the plate I, with which the said latch engages, and a spring M, adapted normally to retain the extension in its closed position, substantially as and for the purpose specified.

No. 58,482. Cycle Chains and Rivets Therefor.
(*Rivets pour chaines de bicycles*)

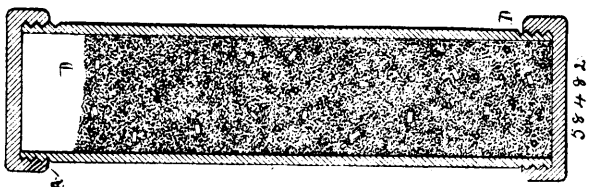

The Indianapolis Chain and Stamping Company, assignee of Humphrey Harrington, both of Indianapolis, Indiana, U.S.A., 23rd December, 1897; 6 years. (Filed 6th November, 1897.)

Claim.—1st. In the process of manufacturing rivets for pitch-chains, first, turning down the reduced necks and cutting off the rivets, second, covering tightly the reduced ends and necks, third, carbonizing mildly the remaining surface, fourth, carbonizing highly a thin coating over the entire surface of the fully shaped rivet, etc., and fifth, hardening by sudden cooling from a red heat, all substantially as herein specified. 2nd. A rivet for bicycle chains having a body and reduced ends, and composed of a core of rivetable metal, a very hard surface layer over the body and ends, and a layer of intermediate hardness on the body between said core and surface layer, said intermediate layer being absent wholly or in large part from the reduced ends of the rivet, substantially as described.

No. 58,483. Means for Preparing the Recording Ribbon, etc. (*Moyen de préparer les rubans à enregistreur.*)

The Ashcroft Manufacturing Company, Bridgeport, Connecticut, assignee of Jarvis Bonesteel Edson, Shelter Island Heights, New York, both in the U.S.A., 23rd December, 1897; 6 years. (Filed 16th November, 1897.)

Claim.—1st. In a ruling device, the combination with the platen of grooved rolls at opposite sides of the platen, endless parallel

marking threads spaced apart by said rolls and co-acting with the platen with their upper runs, and means for rotating one of said

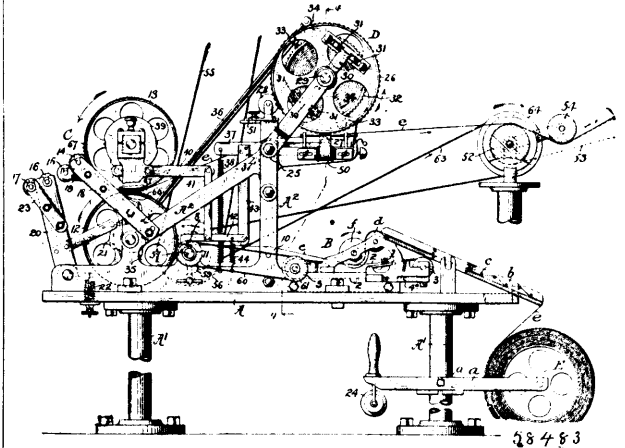

grooved rolls, substantially as described. 2nd. The combination with the platen of grooved rolls at opposite sides thereof, endless marking threads passed around said rolls and co-acting with the platen with their upper runs, and a support for a pattern within the space between the two runs of the threads, substantially as described. 3rd. In a ruling device, the combination of an impression device for the material to be ruled, a plurality of suitably supported parallel marking threads co-acting with the impression device, and a support for a pattern arranged adjacent the threads to act as a guide for the proper location of said threads, as described. 4th. In a ruling device, the combination with the impression roll for the material to be ruled, parallel endless marking threads co-acting at their upper runs with said impression roll, and a pair of grooved rolls around which said threads are stretched, of an auxiliary means of adjustment for said threads, and a pattern holder in the space between the two runs of the threads, substantially as described. 5th. In a ruling device, the combination with the impression roll for the ribbon or strip to be ruled, grooved rolls at opposite sides thereof, means for rotating one of said grooved rolls, endless parallel marking threads spaced apart by said rolls and co-acting at their upper runs with said impression roll, of auxiliary adjusting devices for adjusting the upper runs of the threads independent of the grooved rolls, substantially as described. 6th. In a ruling device, the combination of the impression roll for the ribbon or strip to be ruled, a plurality of parallel endless marking threads co-acting with said impression roll, a pair of grooved rolls around which said threads are stretched, a support for a pattern arranged adjacent each roll, and a plurality of removable pins for transversely adjusting the positions of the threads, as set forth. 7th. The herein-described ruling mechanism, comprising the parallel grooved rolls, one of which is driven, the endless marking threads passing around said drum and spaced by the grooves thereof, a roller platen journaled over the upper run of the threads, a guide and leading roll for guiding the strip to be ruled under said platen, and a pattern holder or support between the two runs of the threads, substantially as described. 8th. The combination with the endless travelling ruling threads and the platen over the upper runs thereof, of an inking device for the threads, an apertured plate under the upper runs of the threads at one side of the platen, and removable pins in said apertures for properly spacing the threads, substantially as described. 9th. The herein-described ruling mechanism, comprising a suitable frame, a bracket for supporting the roll of paper to be printed, a guide-trough above the bracket and having rods for straightening the strip, a leading roll at the forward end of the trough, a platen roll under which the strip passes from the leading roll, parallel grooved rolls at opposite sides of the platen, and the endless ruling or marking threads passed around said grooved rolls, substantially as set forth. 10th. The combination with the frame, and the mechanism for ruling the strip longitudinally, of an impression cylinder around which the strip or ribbon passes from the ruling mechanism, a printing cylinder over the impression cylinder and provided with devices for printing the transverse graduations at the opposite edges of the strip, a consecutive numbering cylinder above the line-ruling mechanism and under which the strip or ribbon passes from the printing cylinder, a platen movable towards and from the said numbering cylinder, and an operating mechanism for actuating the numbering cylinder a single character at predetermined intervals, substantially as described. 11th. The combination with the impression cylinder and the printing cylinder co-acting therewith, of an intermittently actuated rotary numbering cylinder having a spirally arranged series of consecutive numbers and having a sliding overment, a spring projected platen for the numbering cylinder, mechanism for retracting the platen at regular intervals, mechanism actuated from the axis of the printing cylinder to release the platen, and mechanism actuated from the shaft

of the impression cylinder, for operating the numbering cylinder, the space of a single number for every time its platen is released, substantially as described. 12th. The combination with the printing cylinder having a cam on its axis, and an impression cylinder provided with an eccentric, of a rotary numbering cylinder having a rotary shaft on which it slides, and with which it turns, said cylinder having a spirally arranged series of consecutive numbers, and an external spiral groove, a flange entering said groove, a ratchet wheel on the shaft of the numbering wheel, a lever having a pawl engaging said ratchet wheel, and a rod connected at one end to the eccentric and at its opposite end engaging said pawl lever, a lever pivoted below the printing cylinder, and provided at one end with a platen to co-operate with the numbering cylinder, a spring for projecting the platen towards said cylinder, a hooked lever for rocking the platen lever against the action of its spring, a cam having a shoulder to engage and operate said hooked lever, and a trip lever connected with the hooked lever and actuated from the cam on the axis of the printing cylinder, substantially as described. 13th. The combination with the rotary, non-sliding shaft and means for rotating it intermittently, of a cylinder sliding on and turning with said shaft, and having a series of numbers arranged spirally around its exterior, a spiral groove being formed between the lines of numerals, and an idler rotating in fixed bearings and provided with flanges engaging the groove at opposite sides of the line of numerals, substantially as described. 14th. The combination with the numeral carrying cylinder having an external spiral groove, and a flanged idler engaging the groove to cause the cylinder to move endwise when rotated, of rotary non-sliding shaft extending through the cylinder and provided with a parallel arm also passing freely through the cylinder, the said cylinder having antifriction wheels between which said arm passes, substantially as described..

engine to said reversing device, and a connection from the valve of said engine to said dogs. 2nd. In a reciprocating metal paring

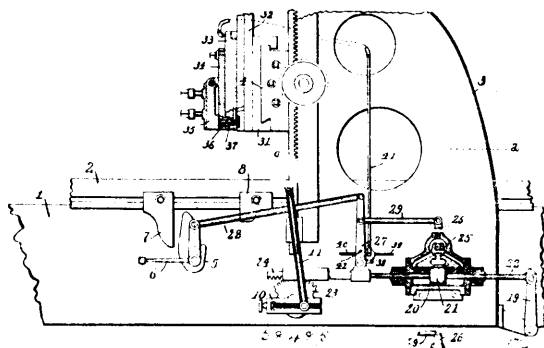

machine, the combination, substantially as set forth, with the main reciprocating part, its driving and reversing mechanism and the feed mechanism of the machine, of a pneumatic engine, a connection from the piston of said engine to said feed mechanism, and a connection from the reversing mechanism of the machine to the valve of said engine. 3rd. In a reciprocating metal paring machine, the combination, substantially as set forth, with the main reciprocating part of the machine, the driving and reversing mechanism thereof, feed mechanism of the machine, and the dogs actuated by said main reciprocating part, of a pneumatic engine, connections from the piston of said engine to said reversing and feed mechanisms, and connections from the valve of said engine to said dogs. 4th. In a reciprocating metal paring machine, the combination, substantially as set forth, with the main reciprocating part of the machine, the driving mechanism thereof, the reversing device for said mechanism and the swinging apron, of a pneumatic cylinder, a piston therein, connections between said piston and the swinging apron of the machine, a controlling valve for said cylinder, and connections between said controlling valve and the reversing mechanism of the machine.

No. 58,484. Artificial Leg. (Jambe artificielle.)

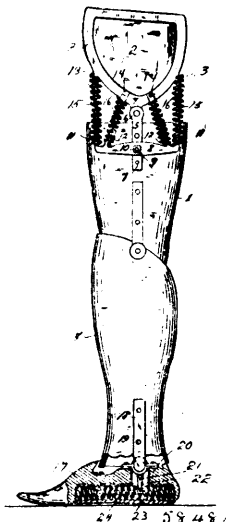

Joseph Turrer, East Toledo, Ohio, U.S.A., 23rd December, 1897; 6 years. (Filed 9th December, 1897.)

Claim.—1st. In an artificial leg, the combination with a frame attached to the upper member of the leg, and pivotally attached to the middle member, of a cross-arm pivotally attached between its ends to said middle member, and springs arranged between the opposite ends of said cross-arm and frame, substantially as described. 2nd. In an artificial leg, the combination with the frame attached to the upper member of the leg, and provided with downwardly lugs, of a metallic strap fixed to the middle member and pivotally connected to said frame, a cross-arm pivoted between its ends to said middle member and provided with upwardly projecting lugs at its opposite ends, and coiled springs fitted at their opposite ends over the said lugs on the frame and cross arm, substantially as described. 3rd. The combination with an artificial leg, and artificial foot articulated thereto and having a rocking motion thereon, a coiled spring arranged in a longitudinal recess in the sole of the foot, and a tang fixed to the leg and projecting down between the convolutions of the spring, substantially as described and for the purpose specified.

No. 58,486. Combination Tool. (Outil à combinaison.)

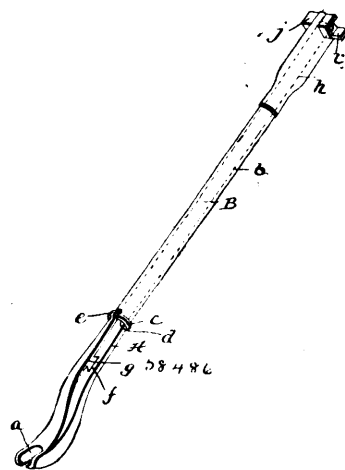

Adam W. Severance, Walla Walla, Washington, U.S.A., 23rd December, 1897; 6 years. (Filed 1st December, 1897.)

Claim.—1st. The combination tool comprising the bar having the claw at one end and the tube receiving the shank or stem of the bar and adapted to be detachably secured thereto and having one or more wrenches at its outer end, substantially as specified. 2nd. The combination tool comprising a bar having a claw at one end and a tube adapted to receive the spike at one end, and also receive the shank or stem of the bar, said shank being of a greater length than the tube and having the catch to engage the tube, substantially as specified. 3rd. The combination tool comprising the bar having a claw at one end and its shank or stem rounded, and also having a spring catch, and the tube having an annular shoulder or flange to be engaged by the catch, and also having its outer or opposite end enlarged to receive a spike, and provided with one or more laterally disposed wrenches, substantially as specified.

No. 58,485. Reciprocating Metal Cutting Machine. (Machine alternative à couper le métal.)

Alexander Gordon, Hamilton, Ohio, U.S.A., 23rd December, 1897; 6 years. (Filed 1st June, 1897.)

Claim.—1st. In a reciprocating metal paring machine, the combination, substantially as set forth, with the main reciprocating part thereof, the driving mechanism thereof, the reversing device for said mechanism, and the dogs actuated by said main reciprocating part, of a pneumatic engine, a connection from the piston of said

No. 58,487. Miner's Candlestick.
(*Flambeau pour mineurs.*)

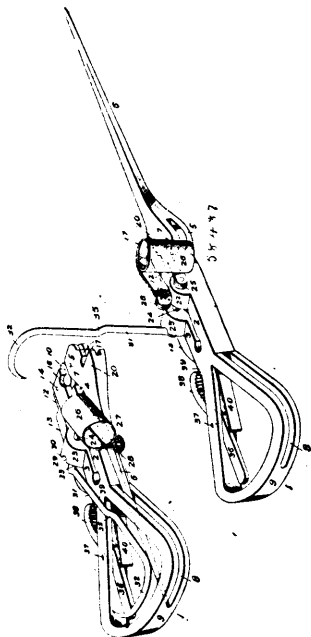

Robert Clinch, Combination, Montana, U.S.A., 23rd December, 1897; 6 years. (Filed 24th November, 1897.)

Claim.—1st. A miner's candlestick, comprising the parallel spring arms 2 and 3, the spike 6 hinged to the arm 2, and the blade 13 pivoted in the arm 3, in combination with the transverse shaft 24, having a collar 25, the candle holder 26 secured thereto, and the hook 32, having its integral shank 31 secured to one end of the shaft 24, substantially as shown and described. 2nd. A miner's implement, comprising the handle bow, having integral parallel spring arms 2, 3, provided with lugs 22, 23, the latter provided with an inclined face 33, notch 29 and shoulder 30, the shaft 24 journalled in said lugs and having an integral collar 25, a candle holder secured to said collar and provided with a lip 27 having retaining lug 28, and the hook 32 having its shank 31 secured to said shaft so as to engage said notch and shoulder on the lug 23, in combination with the spike 6 hinged to the outer end of the arm 2, and its shank adapted to engage the lug on the lip 27, when folded, substantially as and for the purpose set forth. 3rd. A miner's implement, comprising the handle bow, the integral parallel spring arms provided with lugs 22, 23, the latter having an inclined face 33, notch 29 and shoulder 30, the shaft 24 journalled in said lugs and provided at one end with a collar to which is fixed a spring candle clamp and the hook 32 having its shank 31 secured to the other end, in combination with the hinged spike 6, the pivoted knife blade 13, and the lever 36 fulcrumed in the handle bow, and having a serrated jaw contiguous to the recess 39 in one of said arms, substantially as and for the purpose set forth.

No. 58,488. Blacksmith Tongs. (*Ténailles de forgeron.*)

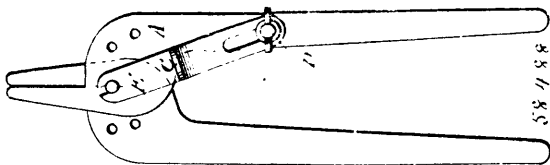

Walter Brown Marble, Laytonville, California, U.S.A., 23rd December, 1897; 6 years. (Filed 24th November, 1897.)

Claim.—In a pair of tongs, a pair of jaws, having each a handle, and a series of openings, for an adjustable pivot, a pivot-pin provided with a retaining-groove, a set-screw seated in one of the handles, and a slotted keeper-plate adjustably held by the set-screw and engaging the groove in the pivot-pin as set forth.

No. 58,489. Knife and Cutter Head for Lathes.
(*Couteau pour poupées de tour.*)

Louis Gilbert Merritt, Lockport, New York, U.S.A., 23rd December, 1897; 6 years. (Filed 4th December, 1897.)

Claim.—1st. The combination in a cutter-head, of a hub provided with wings extending in parallel planes on diametrically opposite

sides thereof, and each extending equally on opposite sides of the shorter diameter of the ellipse formed by the plane of said

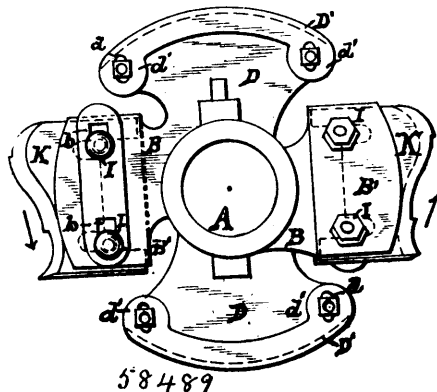

wings cutting the cylinder of rotation, cutting-blades secured to the wings and so arranged that each cutting edge will also occupy equal spaces on opposite sides of the shorter diameter of the ellipse, whereby the centre of the cutting edge engages the work perpendicularly thereto and the adjacent portions thereof approximately so, substantially as and for the purpose specified. 2nd. The combination in a moulding cutter-head for turning-machines, of a hub provided on opposite sides with wings set at a great angle to the axis of the said wings lying in the same plane of rotation and extending equally on opposite sides of a plane passing through the middle of the cutter-head at right angles thereto, the wings being provided with knives the edges of which are interrupted so that only the downward portions of each can engage the work, substantially as specified. 3rd. The combination in a cutter-head for turning-machines, of a hub having two oppositely-extending wings set at a great angle to the axis of the shaft, each wing provided with an oppositely-faced seat, a cutter knife thereon, the cutting edges each being interrupted and occupying equal spaces on opposite sides of the shorter diameter of the ellipse formed by the plane of said wings cutting the cylinder of rotation and the oppositely extending flanges provided with adjustable segments to prevent the work from being drawn into the cutter-head substantially as specified.

No. 58,490. Race-Starting Machine.

(*Mécanisme de partance pour les courses.*)

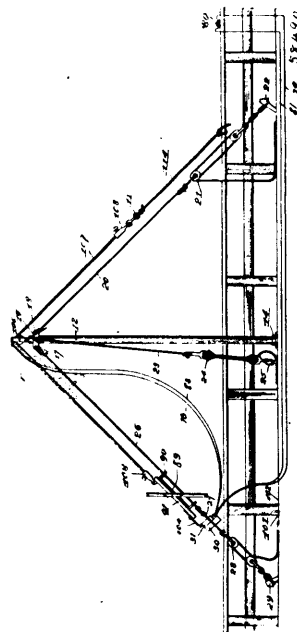

William Percy Maxwell, St. Louis, Missouri, U.S.A., 23rd December, 1897; 6 years. (Filed 12th November, 1897.)

Claim.—1st. In a device of the class described, a suitable barrier movably suspended across the track and electrically operated mechanism for holding and releasing said barrier, which mechanism consists of electro-magnets, armatures operated by said magnets, pivotally mounted jaws adjacent to said magnets, toggle-joints operating the free ends of the posts supporting said jaws, trip-

mechanisms for holding and releasing said toggle-joints and in positions to be operated by said armatures, and hooks attached to said barriers and designed to engage said jaws, substantially as specified. 2nd. In a device of the class described, inclined wires upon opposite sides of the track and extending in a direction parallel with the track, frames slidably positioned upon said wires, rollers carried by said frames in a vertical position, a netting attached to and connecting said rollers, electrically controlled mechanisms rigidly fixed in positions adjacent the lower ends of said wires, each of said electrically controlled mechanisms consisting of an electro-magnet, an armature operated by said magnet, a post pivotally mounted adjacent said magnet, a jaw extending from the free end of said post at right angles thereto, a toggle-joint operating the free end of said post, trip-mechanism for holding and releasing said toggle-joint and in a position to be operated by said armature, an electric circuit operating said magnets and hooks upon said sliding frames and engaging said jaws, substantially as specified. 3rd. In a device of the class described, inclined wires upon opposite sides of the track and extending in a direction parallel with the track, frames slidably positioned upon said wires, elastic cords attached to said frames in such a way that their tension will be exerted to elevate said frames, a suitable barrier connecting said frames, electrically controlled mechanism rigidly fixed in positions adjacent the lower ends of said wires, each of said electrically controlled mechanisms consisting of an electro-magnet, an armature operated by said magnet, a post pivotally mounted adjacent said magnet, a jaw extending from the free end of said post at right angles thereto, a toggle-joint operating the free end of said post, trip-mechanism for holding and releasing said toggle-joint and in a position to be operated by said armature, an electric circuit operating said magnets and hooks upon said sliding frame and engaging said jaws, substantially as specified. 4th. In a device of the class described, posts upon opposite sides of the track, guy-ropes extending from the tops of said posts in an inclined direction to the ground, stakes driven in the ground, to which the lower ends of said guy-ropes are attached, certain of said guy-ropes forming inclined supports upon opposite sides of the track, a suitable barrier suspended across the track and slidably connected with said inclined supports, electrically operated mechanism for holding and releasing said barrier carried by said inclined supports, elastic cords attached to said barrier in such a way that their tension will be exerted to elevate said barrier, which electrically controlled mechanism consists of electro-magnets, armatures operated by said magnets, pivotally mounted jaws adjacent to said magnets, toggle-joints operating the free ends of the posts supporting said jaws, trip-mechanism for holding and releasing said toggle-joints and in position to be operated by said armatures, and hooks attached to said barriers and designed to engage said jaws, substantially as specified.

No. 58,491. Organ. (Orgue.)

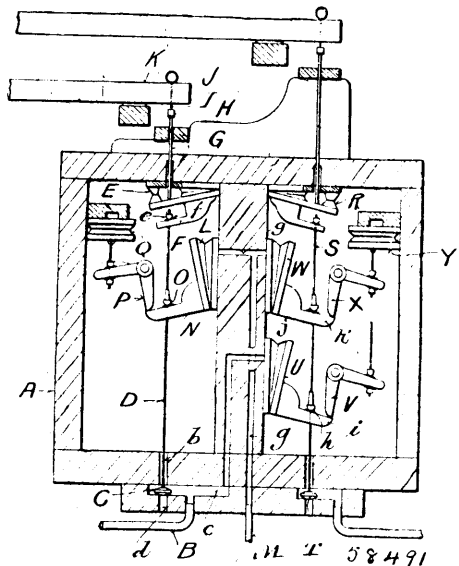

William Schluelke, Milwaukee, Wisconsin, U.S.A., 23rd December, 1897; 6 years. (Filed 29th November, 1897.)

Claim.—1st. The combination of the key-box wherein wind-pressure is constant, a pneumatic in said box, a valve having its stem connected to the pneumatic, a key-sticker extended into said pneumatic to normally distend the same against wind-pressure thereon. 2nd. The combination of the key-box wherein wind-pressure is constant, a pneumatic in said box, a valve having its stem connected to the pneumatic, a sticker extended into said pneumatic to normally distend the same against wind-pressure thereon, a key,

and a block on the stem in opposition to the sticker. 3rd. The combination of the key-box wherein wind-pressure is constant, a pneumatic in said box, a valve having its stem connected to the pneumatic but movable independent of the same as well as therewith, a key-sticker extending into said pneumatic to normally distend the same against wind-pressure thereon, and a coupling-action co-operative with the valve-stem. 4th. The combination of the key-box wherein wind-pressure is constant, a pneumatic in said box, a valve having its stem connected to the pneumatic but movable independent of the same as well as therewith, a key-sticker extending into said pneumatic to normally distend the same against wind-pressure thereon, a coupling-pneumatic having an arm loosely engaged by the valve-stem, a resistance device on said stem opposing lift of the pneumatic-arm, and a pneumatically-controlled check for said arm.

No. 58,492. Protector for Lamps.

(*Protecteur de lampes.*)

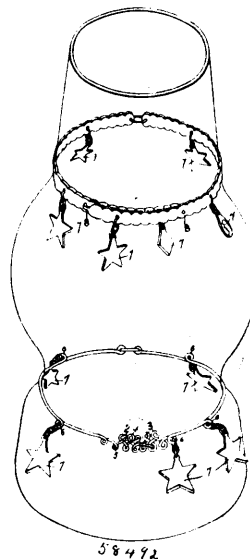

Josef Kulesar, Concord Junction, Mass., U.S.A., 23rd December, 1897; 6 years. (Filed 2nd December, 1897.)

Claim.—1st. As an article of manufacture the herein described securing device for lamp-chimneys, consisting of the metal collar having a series of perforations and provided with a series of depending sections resting in direct contact with the outer surface of the chimney and adapted to ornamentation, and hooks formed upon either end of the collar and arranged to engage in apertures provided in the contiguous ends thereof, as and for the purpose set forth. 2nd. The herein described lamp-chimney protector and temperature-equalizing device substantially as shown, consisting of the metal collar adapted to expand and contract in sympathy with the chimney and carrying heat absorbing contact points arranged to depend therefrom and lie in direct contact with the surface of the chimney and means for adjusting the ends of said collar in contact with each other, as and for the purpose named.

No. 58,493. Colour Printing Machine.

(*Machine pour imprimer en couleur.*)

Jules Meyrueis, of 189 Boulevard Saint Germain, Paris, France, 23rd December, 1897; 6 years. (Filed 19th June, 1897.)

Claim.—1st. A rotary printing machine composed of parallel stages or frames supporting trains of printing pressing and inking cylinders at equal distances from each other, substantially as described. 2nd. A rotary printing machine composed of trains of printing pressing and inking cylinders arranged with the axes of the cylinders of the same kind in one and the same plane. 3rd. A rotary printing machine composed of parallel stages or frames supporting trains of printing pressing and inking cylinders at equal distances from each other, and tension rollers for the paper arranged, substantially as described and for the purpose stated. 4th. A rotary printing machine composed of trains of printing pressing and inking cylinders and tension rollers for the paper sheets, all mounted in bearings adjustable on the machine frame, and change gear-wheels adjustable in slots in the machine frame, substantially as and for the purpose stated. 5th. In a rotary printing machine, an inking apparatus consisting of a cylindrical table, a sector frame carrying distributing rollers in contact with said table and pivoted on the axle thereof and adjustable thereover, substantially as and for the purpose stated. 6th. In a rotary lithographic printing machine, an

inking apparatus consisting of a cylindrical table, an oblique disc and a spur-wheel fast on one or on both ends of the spindle of said

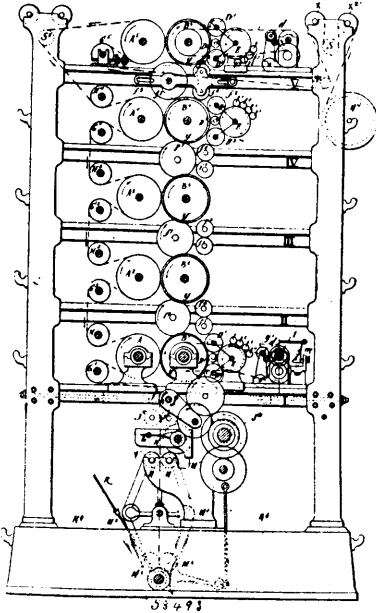

table, a series of distributing rollers in contact with the cylindrical table, a grooved roller and a pinion-wheel fast on one or on both ends of the spindle of each roller and gearing with the disc and spur-wheel aforesaid, substantially as and for the purpose described. 7th. In a rotary lithographic printing machine, a moistening or damping apparatus consisting of cylinders of cloth and of sponge, arranged substantially as and for the purpose described. 8th. In a rotary printing machine, a paper cutting apparatus consisting of a fixed cutter or knife and a rotary cutter or blade mounted screw fashion or helically on an adjustable support, substantially as and for the purpose described. 9th. In a rotary printing machine, apparatus for laying the cut paper alternately on each side of the cutter, consisting of a rocking layer the axis of which is toothed and operated by a toothed sector lever actuated by a link connected to the last wheel in a train geared to the last printing cylinder, substantially as described. 10th. In a rotary printing machine, a final roller on to which the printed paper and a web of set off paper from a reserve roll are continuously wound, substantially as described. 11th. In a rotary printing machine, a printing cylinder made up of four sectors arranged on a central screwed shaft and adjustable longitudinally thereover by screw-threaded rods and circumferentially by studs and grooves, substantially as and for the purpose hereinbefore set forth. 12th. The combination with a rotary printing machine, of a dynamo fixed on the frame and connected to the driving axle of the machine by gearing, the commutator being connected to the paper guide cylinders G, H, substantially as and for the purpose hereinbefore set forth. 13th. The combination with a rotary printing machine, of an electrical resistance device arranged inside the paper guide cylinders G, H, substantially as and for the purpose hereinbefore set forth. 14th. In a rotary printing machine with parallel frames, the arrangement of the cylinders vertically, one above the other and the placing of the pressing or blanket cylinders A, at the top or upper part of the printing cylinders B, substantially as and for the purpose hereinbefore set forth.

No. 58,494. Printing Press. (*Presse à imprimer.*)

Frederick John Harbridge, Gravenhurst, Ontario, Canada, 23rd December, 1897; 6 years. (Filed 1st October, 1897.)

Claim.—1st. In a printing press, in combination, the cylinder, the feeding table arranged to deposit the sheet upon the cylinder to be printed, and a delivery table located underneath the feeding table suitably supported and arranged to receive the sheet after being printed, as and for the purpose specified. 2nd. In a printing press, in combination, the cylinder, the feeding table pivotally supported at the front end on the frame and having the rear end extended into proximity with the cylinder, and means for lowering the rear end of the feeding table to deposit the sheet upon the cylinder and for raising it to allow of the depositing of the printed sheet upon the delivery table, as and for the purpose specified. 3rd. In a printing press, in combination, the cylinder, bearing standards for the end spindles thereof, guide-ways for the bottom of such standards upon which they have longitudinal movement, a forwardly extending bar attached to one standard and having an inclined intermediate portion, the feeding table pivotally swung on the frame, the hanger and roller designed to have movement upon the inclined way of the bar attached to the bearing standards as and for the purpose

specified. 4th. In a printing press, in combination, the cylinder, means for imparting a rotary and longitudinal movement to same

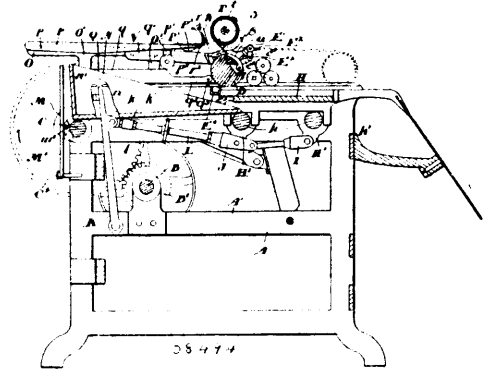

as it rotates, the feeding table provided with a hinged end flap spring-held, the stop fingers and means for gripping the paper to fasten it to the cylinder as it leaves the rear end of the table, as and for the purpose specified. 5th. In a printing press, in combination, the cylinder, means for imparting a rotary and longitudinal movement to same as it rotates, the feeding table provided with a hinged end flap spring-held, the stop fingers, the arc-shaped spring-held gripping fingers, the recesses in the cylinder, the rod to which the gripping fingers are secured extending through such recess and the ends of the cylinder, and means for opening and closing the gripping fingers, as and for the purpose specified. 6th. In a printing press, in combination, the cylinder, means for imparting a rotary and longitudinal movement to same as it rotates, the feeding table provided with a hinged end flap spring-held, the stop fingers, the arc-shaped spring-held gripping fingers, the recess in the cylinder, the rod to which the gripping fingers are secured extending through such recess and the ends of the cylinder, the crank-shaped end on the rod, the bar secured to the side of the frame and provided with end guiding ribs designed to co-act with the crank arm on the end of the rod of the gripping fingers, as and for the purpose specified. 7th. In a printing press, in combination, the cylinder, means for imparting a rotary and longitudinal movement to same as it rotates, the feeding table provided with a hinged end flap spring-held, the stop fingers, the arc-shaped spring-held gripping fingers, the recess in the cylinder, the rod to which the gripping fingers are secured extending through such recess and the ends of the cylinder, means for opening and closing the gripping fingers and a projection plate designed to come in contact with one of the gripping fingers to momentarily depress the flap, as and for the purpose specified. 8th. The combination with the cylinder and gripping fingers, of the spring smoothing fingers and means for bringing them upon the cylinder and paper thereon after the gripping fingers have grasped the paper and the cylinder has started to rotate in its rearward movement, as and for the purpose specified. 9th. The combination with the cylinder and gripping fingers, of the spring smoothing fingers and means for bringing them down upon the cylinder and paper thereon after the gripping fingers have grasped the paper and the cylinder has started to rotate in its rearward movement, and means for raising the fingers when the cylinder has reached the limit of its rearward movement as and for the purpose specified. 10th. The combination with the cylinder and gripping fingers, of the spring smoothing fingers, the clamped cross rod on which they are held, the end arms for the same and the bearing standards having arms on which such arms are pivoted, the depending arm from the cross rod, the bent projection with which the lower end of the arm is designed to come in contact when the cylinder has about reached the limit of its forward movement, as and for the purpose specified. 11th. The combination with the cylinder and gripping fingers, of the spring smoothing fingers, the clamped cross rod on which they are held, the end arms for the same and the bearing standards having arms on which such arms are pivoted, the depending arm from the cross rod, the bent projection with which the lower end of the arm is designed to come in contact when the cylinder has about reached the limit of its forward movement, and the raised inclined block fastened to the bed and with which the depending arm is designed to come in contact, as and for the purpose specified. 12th. In combination the feeding table, the cylinder and the gripping fingers, the tapes attached at one end to the gripping fingers, a rewinding means for holding the opposite ends of the tapes and a clamping bar secured on such tapes and designed to hold the opposite end of the sheet to that which the gripping fingers hold, as and for the purpose specified. 13th. In combination the feeding table, the cylinder and the gripping fingers, the tapes attached at one end to the gripping fingers, the rod and grooved wheels carrying the opposite end of the tapes, the clamping bar secured in the tapes and designed to hold upon the cylinder, the opposite edge of the sheet to that which the gripping fingers hold and means to allow of the tapes unwinding from the grooved wheels as the cylinder moves rearwardly and of causing the tape to rewind

as the cylinder resumes its normal position, as and for the purpose specified. 14th. In combination the feeding table, the cylinder and the gripping fingers, the tapes attached at one end to the gripping fingers, the rod and grooved wheels carrying the opposite end of the tapes, the clamping bar secured in the tapes and designed to hold upon the cylinder the opposite edge of the sheet to that which the gripping fingers hold, and a helical spring secured at one end to the rod of the grooved wheels and at the other end to portion of the frame, as and for the purpose specified. 15th. In combination the cylinder, the chase, the eccentric bars, the arms attached to same, the forked rod I, the forked bracket J, the lever F having lugs k, the bracket k', the screw spindle having right and left hand thread extending into the forked bracket J and bracket k', and means for imparting a rocking movement to the lever, as and for the purpose specified. 16th. In combination the cylinder, the chase, the eccentric bars, the arms attached to same, the forked rod I, the forked bracket J, the lever K having lugs k, the bracket k', the screw spindle having right and left hand thread extending into the forked bracket J and bracket k', and cam M on the main shaft for imparting a rocking movement to the lever, as and for the purpose specified. 17th. In combination the cylinder, the chase, the eccentric bars, the arms attached to same, the forked rod I, the forked bracket J, the lever K having lugs k, the bracket k', the screw spindle having right and left hand thread extending into the forked bracket J and bracket k', cam M on the main shaft for imparting a rocking movement to the lever, the annular groove in the collar of the cam and the pivoted lever with pin extending into the groove so as to impart a lateral movement to the cam, as and for the purpose specified.

No. 58,495. Road Gate. (Barrière de chemins.)

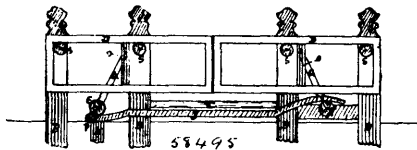

James Lewis McCrea, Palmerston, Ontario, Canada, 24th December, 1897; 6 years. (Filed 23rd November, 1897.)

Claim.—The combination of double cranks H, H, and the railing shafts E and F, and connecting rod J, with levers G, and pinions L, L, and crank T, and link I, with eye P, with slat bars O, combined, substantially as and for the purpose hereinbefore set forth.

No. 58,496. Valve. (Soupape.)

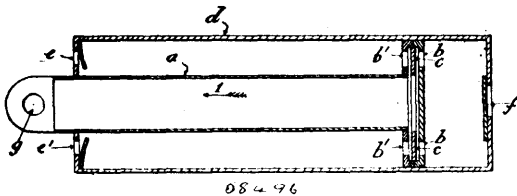

Harry Morrison, 23 Glenpark Road, Forest Gate, Essex, England, 24th December, 1897; 6 years. (Filed 6th December, 1897.)

Claim.—1st. The combined construction and arrangement of the various parts substantially as described and illustrated herein. 2nd. In pumps or the like, a hollow piston head provided with apertures, a movable washer inside piston head so arranged as to close the apertures in either face of the piston head according to the direction of motion of the piston, inlet valves upon the cylinder in which said piston works, said piston being hollow and provided with an outlet or outlets for compressed air.

No. 58,497. Rubber Conveyer Attachment for Harvesters. (Attache de transport en caoutchouc pour moissonneuses.)

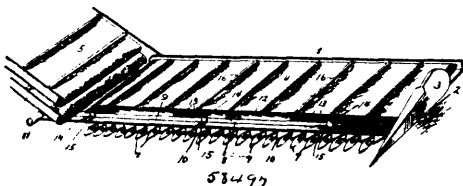

David E. Loger, Ocheyedan, Iowa, U.S.A., 24th December, 1897; 6 years. (Filed 4th December, 1897.)

Claim.—As a new article of manufacture, a butt-feeding attachment adapted to be detachably secured to the cutter bars or

harvesters and similar machines to co-operate with the transverse conveyer-aprons, said attachment consisting of a continuous strip approximately equally in length with the upper or exposed side of the apron and having its upper edge serrated, and angle-brackets the vertical arms of which are permanently secured to the said strip, and the horizontal arms of which extend below the lower edge of said strip and are provided with openings for the passage of bolts, by means of which the strip may be secured to the cutter bar, substantially as described.

No. 58,498. Car Coupler. (Attelage de chars.)

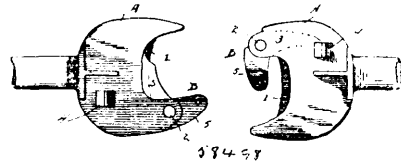

Amos Bopp, Baltimore, Maryland, U.S.A., 24th December, 1897; 6 years. (Filed 4th December, 1897.)

Claim.—1st. In a car-coupler, the combination with a draw-head member having an upper concavity provided with a vertical face to allow a free vertical movement in relation to the opposite draw-head, and being provided with a lower edge projecting beyond the upper concavity, of a knuckle having a vertical diameter equal to that of the head and provided with a broadened convex upper portion having a vertical face projecting beyond the lower portion of the knuckle to form a shoulder arranged and adapted to enter the concavity, and to engage the lower ledge, substantially as described. 2nd. In a car-coupler, the combination with a draw-head member provided with a concaved recess having a vertical face and projecting beyond the upper recessed portion thereof, a knuckle having its top flush with the top of the draw-head and being provided with a broadened portion 5 having a shoulder 7, a rounded vertical face on the shoulder, the broadened portion being made to fit closely within the concaved recess of the opposing draw-head, whereby the two draw-heads have a free vertical up-and-down movement in relation to each other, substantially as shown and described.

No. 58,499. Grain Door for Freight Cars. (Porte pour chars à grain)

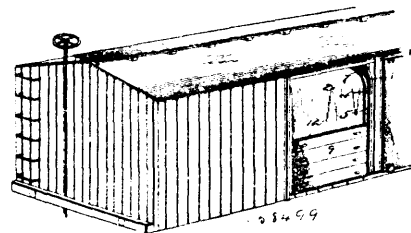

Joseph Wright, Lancaster, Wisconsin, U.S.A., 24th December, 1897; 6 years. (Filed 6th December, 1897.)

Claim.—The combination with a freight car having door openings on opposite sides, of grooved ways extending up the sides of the door openings and across the roof of the car, said ways being continuous from the floor on one side of the car to the floor on the opposite side and wider at the corners or bends than in the straight portions, and a grain door for each door opening, each door consisting of a series of independently movable sections supported to slide in said ways, and the several sections of each door being independently movable from one door opening to the other, whereby a part of one of the grain doors may be used on one side of the car and the other part moved over to the other side to co-operate with the other grain door, substantially as described.

No. 58,500. Gate. (Barrière.)

John Lane, Holly, Michigan, U.S.A., 24th December, 1897; 6 years. (Filed 6th December, 1897.)

Claim.—1st. In a gate, the combination of stiles having cast integral therewith elbows at top and bottom, having therein rabbeted recesses, a compound top and bottom rail made of two sections, the ends of which are adapted to fit into the recesses, a wire fabric interposed between the sections of the rails at the top and bottom, and longitudinally held to the stiles, and means whereby

the whole is firmly and rigidly fastened together, substantially as described. 2nd. In a gate, the combination of double rails located

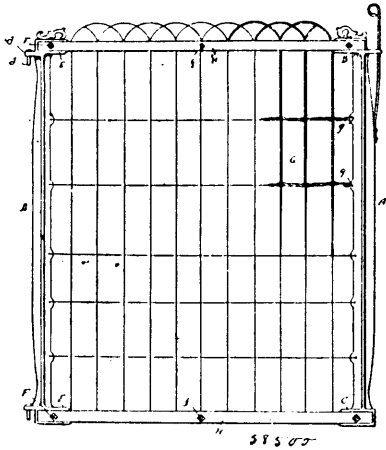

side by side, a double rail being at the top and one at the bottom, a wire-netting comprising a panel for the gate interposed between the sections of the rails, and means whereby the sections are firmly clamped together upon the wire netting, substantially as described.

No. 58,501. Nut Lock. (Arrête-écrou.)

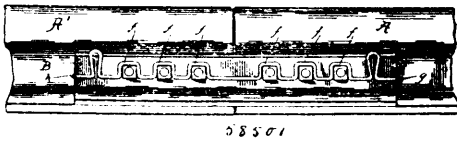

Albert H. Lawfer, Duncansville, Pennsylvania, U.S.A., 24th December, 1897; 6 years. (Filed 6th December, 1897.)

Claim.—1st. A nut-lock comprising a bar or wire formed with a plurality of nut-receiving loops or openings, a laterally-projecting hook at each end, and a vertical impinging piece adjoining one of said hooks, substantially as described. 2nd. The combination with rails, fish-plates at the adjoining ends thereof, bolts connecting said rail and fish-plates and nuts on the ends of the bolts of a nut-lock bar provided with a series of nut-receiving loops, the central sides of which hang upon said nuts, and having end-hooks clamped between said fish-plates and rails, and a spring-impinging piece adapted to impinge against the underside of the rail-head and thereby press the bar down against the nuts, substantially as described.

No. 58,502. Sheet Metal Can. (Boîte métallique.)

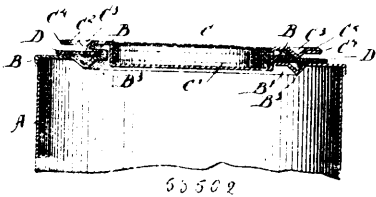

Frank Hazen Palmer, Brooklyn, New York, U.S.A., 24th December, 1897; 6 years. (Filed 6th December, 1897.)

Claim.—1st. A can having a centrally apertured top and having an annular recess concentric to the aperture of the top, the top having an outwardly-bent flange, a packing ring concentric to the aperture of the top, the inner edge of the packing ring being clamped by the flange and the packing ring extending over the annular recess, and a cover having a centrally depressed portion snugly fitting within the aperture of the top, the cover having also an outwardly extending portion formed with a rib capable of being pressed into the recess of the top and of pushing the packing ring within said recess, the outwardly-extending portion of the cover being capable of projecting beyond the periphery of the ring, substantially as described. 2nd. A can having a centrally apertured top and having an annular recess outward from the aperture of the top, the top having an outwardly-extending flange, a packing ring extending over the annular recess, and a cover having a centrally depressed

portion fitting within the aperture of the top, the cover also having an outwardly-extending portion formed with a rib capable of being pressed into the recess in the top and of pressing the packing ring within said recess, substantially as described. 3rd. A can having an apertured top, a cover having a depressed portion fitting within the aperture of the top, one of said parts having a flange at its edge, and a packing ring, the edge of which is held by the flange, the packing ring extending horizontally over the top of the can and outward from the aperture therein, the top and cover respectively having an interlocking rib and recess into which the packing ring is pressed, substantially as described. 4th. A can having an apertured top, a cover fitting over the top, one of said parts having at its edge a flange, and a packing ring, the edge of which is held by the flange, the cover and top respectively having an interlocking rib and recess into which the packing ring is passed, substantially as described. 5th. In a can, an apertured top therefor, a cover resting on the top, one of the two last-named elements having a flange, and a packing ring, one edge of which is permanently held by the flange, the cover and top respectively having an interlocking rib and recess into which the packing ring is pressed, substantially as described.

No. 58,503. Boiler Furnace. (Fournaise de chaudières.)

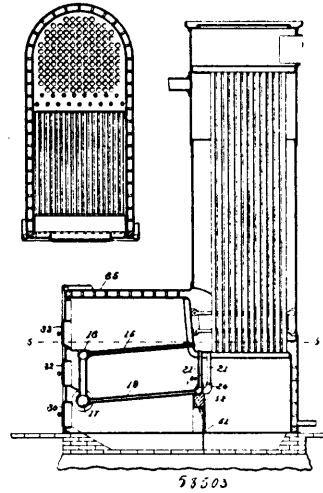

Edward Benjamin Parkhurst, Woburn, Massachusetts, U.S.A., 24th December, 1897; 6 years. (Filed 7th December, 1897.)

Claim.—An upright boiler having the main water-space thereof entirely at the rear of the main fuel chamber, and the combustion chamber beneath the said water space, and also having vertical water walls extending down around the said combustion chamber and forward on opposite sides of the fuel chambers, an upper series of water grate bars entering the front side or shell of the said main water-space near the lower edge of the said front side, a lower series of water grate bars having their rear ends joined to vertical connections entering the lower tube sheet, and a water-box or manifold having upper and lower portions which are connected with each other and also with the front ends of the water grate bars of the two series, respectively, the said water-box or manifold also communicating with the water walls, substantially as described.

No. 58,504. Axle and Axle Boxes. (Essieu et boîte d'essieux.)

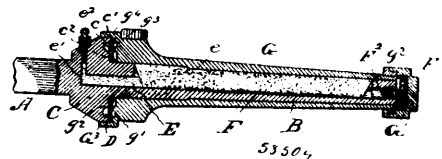

McKendree F. Bishop, Alameda, California, U.S.A., 24th December, 1897; 6 years. (Filed 9th December, 1897.)

Claim.—1st. An axle spindle provided with a central bore adapted to hold a lubricant, an outer axle-box revolvably mounted on said spindle, a groove penetrating the wall of said spindle and leading from central bore to said axle-box, one end of said bore terminating in an upwardly leading channel while the opposite end leads from the extremity of the spindle, and removable means for closing both extremities of said bore for the purpose set forth. 2nd. An axle spindle provided with an inner shoulder, an outer axle-box mounted on said spindle, a longitudinally adjustable nut mounted on the outer end of said box and an axle cap screw-threaded on said box to enclose the outer end of the box and spindle as set forth

3rd. An axle spindle provided with a central bore, an outer axle-box removably mounted on said spindle, a chamber leading from said central bore to said axle-box, a headed bolt screw-threaded into the outer extremity of said bore, and an outer cap adapted to revolve with said axle-box and enclose said headed bolt, substantially as set forth. 4th. An axle spindle provided with an inner shoulder, an outer axle-box provided with an inner shoulder, either one of said shoulders being formed with a facial flange or projection, and an interposed packing between said shoulders, for the purpose set forth. 5th. A lubricating packing for axles formed of felt or other suitable absorbent material, one edge of said packing being longer than the opposite edge, for the purpose set forth.

No. 58,505. Car Coupler. (Attelage de chars.)

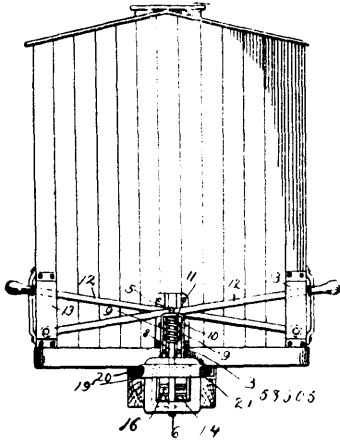

Robert E. Bates, Spring Green, Wisconsin, U.S.A., 24th December, 1897; 6 years. (Filed 9th December, 1897.)

Claim.—1st An automatic car coupling comprising the tubular draw-bar 1, the vertical bracket 3 fixed thereto, the integral coupling bar and pin having a vertical movement in said draw-bar and bracket, the bifurcated lever 8 pivoted to said coupling bar and fulcrumed in the parallel strips 9, 9, pivoted in said bracket and having its rear end projecting into the path of the transversely-crossed levers 12, 12, substantially as shown and described. 2nd. An automatic car coupling comprising the tubular draw-bar 1, the vertical bracket 3 fixed thereto, the integral coupling bar and pin having a vertical movement in said draw-bar and bracket, the bifurcated lever 3 pivoted to said coupling-bar and fulcrumed in the parallel strips 9, 9, in combination with the follower 14, fulcrumed on the bolt 15 in said tubular bar and its bifurcated forward extending on each side of the coupling-pin, and connected to said bifurcated lever by a line 18 so as to move simultaneously with said bifurcated lever, substantially as shown and described. 3rd. An automatic car coupling, comprising the tubular draw-bar 1, the vertical bracket 3 fixed thereto, the integral coupling bar and pin having a vertical movement in said draw-bar and bracket, the bifurcated lever 8 pivoted to said coupling bar and fulcrumed in the parallel strips 9, 9, pivoted in said bracket and having its rear end projecting into the path of the transversely-crossed levers 12, 12, in combination with the follower 14, the V-shaped spring 16 engaging said follower and the yoke 19, the horizontal plate 22 fixed thereto and spiral spring 11 encompassing the parallel arms of said yoke, substantially as shown and described.

No. 58,506. Rail Joint, and Method of Forming the Same. (Joint de rail, et méthode de fabrication.)

William J. Austin, Milwaukee, Wisconsin, U.S.A., 27th December 1897; 6 years. (Filed 1st December, 1897.)

Claim.—1st. An improved rail joint, comprising a metal sleeve or support, shaped on its interior to conform to and closely embrace a pair of rail ends, and provided with an interior recess or cavity upon each side, a pair of rail ends fitting within said sleeve or support, and provided with apertures in their webs, and a filling of cast metal flowed into said cavity or recess and through said apertures. 2nd. An improved rail joint, comprising the abutting ends of a pair of rails provided with apertures in the web thereof, a metal sleeve or support in two parts shaped to embrace the base flanges of the rails and to form a recess or cavity on each side between the sleeve and the opposing portions of the rails, a rigid connection between the parts of the sleeve, and a metal filling cast in said cavity or recess. 3rd. An improved rail joint, comprising the abutting ends of a pair of rails provided with apertures in the webs thereof, a metal sleeve or support in two parts shaped to embrace the base flanges of the rails, and having projecting lips or flanges formed to project over the base flanges of the rails, with upwardly projecting sides forming a recess or cavity on each side of

the web of the rails, a rigid connection uniting the parts of the sleeve, and a metal filling cast in the cavity or recess. 4th. A

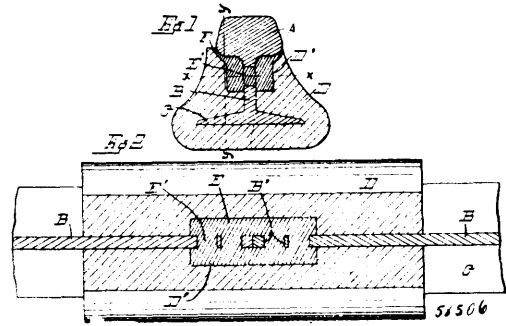

method of joining rail ends, consisting in adjusting upon a pair of aligned rail ends a metal sleeve or support, conforming to the contour of said rail ends and having a cavity or recess in its interior, and pouring molten metal into said cavity. 5th. A method of joining rail ends, consisting in adjusting upon a pair of aligned and perforated or aperture rail ends a metal sleeve or support shaped upon its interior surface to conform to the contour of the rail ends and provided in its interior with a cavity or recess, pouring molten metal into said cavity and through the perforations in the rail ends, and fusing the partitions between said perforations to said cast-metal filling.

No. 58,507. Garment Protector. (Protecteur de vêtement.)

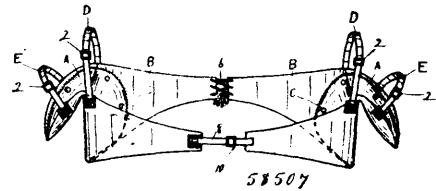

Kate E. Schooley, Vancouver, British Columbia, 27th December, 1897; 6 years. (Filed 30th November, 1897.)

Claim.—1st. A garment protector of the character described, consisting of a band widened out and designed to fit and to fully cover the arm pits, garment protectors of suitable material, attached to, and capable of detachment from the inner side of said widened parts of the band, said band having upper supports, and laced at the back, and adjustable strap in front, as described. 2nd. A garment protector consisting of a body band widened out and designed to fit and to fully cover the arm pits, protectors of suitable material attached to and capable of detachment from the inner side of said widened out parts of the band, by means of suitable fastenings connected thereto, adjustable shoulder and arm straps on the band, and laced at the back, and adjusting strap in front, as described.

No. 58,508. Filter-Press Plate.

(Plaque de presses à filtre.)

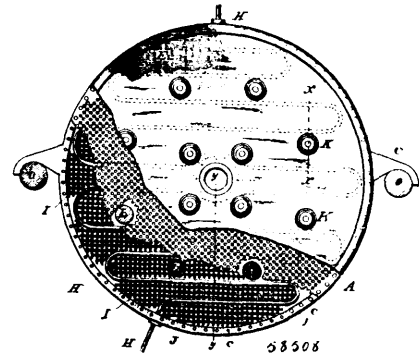

Horace P. Chamberlain, Buffalo, New York, U.S.A. 27th December, 1897; 6 years. (Filed 9th December, 1897.)

Claim.—1st. In a filter-press plate, two perforated plates, canvas covers on the outer sides thereof, a series of separating-discs upon

said canvas covers and canvas washers under said separating-discs, being secured to the plates and covers by bolts having countersunk heads in one of the said series of separating-discs, and angular nuts embedded in corresponding recesses in the opposite series of separating-discs, as set forth. 2nd. A filter-press plate consisting of two perforated plates separated a suitable distance as described, a canvas covering on the outer sides of these plates, a heating-coil between these perforated plates, and a filling between the plates adapted to sustain the plates against pressure and to permit the passage of the filtered substance, as and for the object specified. 3rd. In a filter-press plate, a heating-coil between two adjacent plates, a separating ring between the said plates and a filling of reticulated fabric between the said plates and around the said heating-coil, as set forth. 4th. A filter-press-plate composed of two perforated plates, an outer ring to which the two plates are secured at their periphery, an inner ring to which the two perforated plates are affixed around their central opening, a canvas covering on the outer sides of said perforated plates, a heating-coil, and a filling between said perforated plates, as and for the object set forth. 5th. In a filter-press plate, the combination, with two perforated plates separated by an outer and inner ring, of two canvas covers, one on each side of the said perforated discs, said canvas covers having their outer periphery doubled, a U-shaped ring of canvas passed over the doubled-up portion of said covers and stitched thereto, a series of canvas rings interposed between said canvas covers near their central openings and stitched together as described, said canvas covers being tied together at their peripheries, as and for the object stated. 6th. A filter-press plate consisting of two perforated plates, an outer and an inner ring to which said plates are affixed, a heating-coil and reticulated rod-fabric between said perforated plates, canvas covers on the outer sides of said perforated plates, a series of separating discs on the outer surface of the canvas covers, and a like series of filling-discs between the perforated plates, as and for the purpose specified.

No. 58,509. Moulding Device. (Appareil pour mouler.)

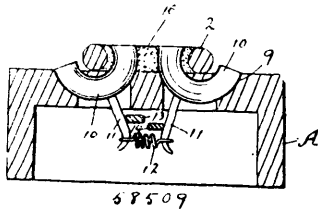

Edwin Fabian, St. Paul, Minnesota, U.S.A., 27th December, 1897; 6 years. (Filed 11th December, 1897.)

Claim.—For the manufacture of cast-metal chains, means for forming cores in the several links to be connected into a chain, consisting of a suitable moulding-table adapted to support a link in substantially horizontal position thereon, the pair of oppositely disposed, similar circular patterns working in a vertical plane through the top of said table, the dimensions and curvature of said patterns corresponding to those of the ends of the links to be formed, and being so disposed as to project their adjacent ends upward through the link laid upon said table, the depending arms upon said patterns, the spring normally holding said arms drawn together so as to project the adjacent ends of the patterns upward, and the pivoted levers engaging said arms and adapted to withdraw said patterns from said link.

No. 58,510. Headlight. (Fanal de locomotive.)

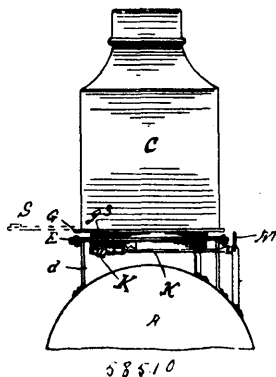

Oscar A. Comstock, Amboy, Illinois, U.S.A., 27th December, 1897; 6 years. (Filed 13th December, 1897.)

Claim.—The combination with a locomotive railway engine of the herein-described headlight, revolubly mounted thereon, consisting

of a casing provided with a base-plate G to which is secured a circular plate g having an annular depending rim g², the periphery of which is provided with serrations or teeth g³, and having also an annular outwardly directed rim or flange g⁴, said plate g being revolubly mounted in the annular plate E mounted on supports d secured to the boiler of the engine, said plate E having an upwardly directed rim E² upon which the flange g⁴ of the plate G rests, said plate E having an annular depending flange F² provided with cross-bars F³ united by a central circular base-plate F⁴, to which the plate G is pivotally connected by means of a bolt and nut, keepers secured to the under side of the cross-bars F³, and worm-gearing revolubly mounted in said keepers, adapted to engage the ratchet-teeth g³ of the plate g and a shaft K connected with said worm-gearing, and having connections with a crank-handle mounted adjacent to the cap whereby the headlight may be turned in any direction, as herein set forth and described.

No. 58,511. Gas Stove. (Poêle à gaz.)

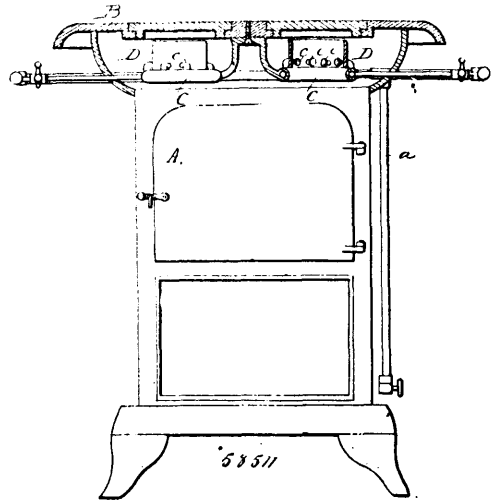

Jonathan Johnson, Lowell, Massachusetts, U.S.A., 27th December, 1897; 6 years. (Filed 22nd November, 1897.)

Claim.—1st. In a gas stove, the combination with a series of burners having converging orifices and adapted to produce flames that are horizontal and spread laterally without lengthening in the same proportion, said burners being disposed opposite to each other so that the issuing flames project towards each other, of a shield or air-shaft surrounding said burners and allowing a current of air to pass transversely through the sheet of flame formed as specified, substantially as described. 2nd. In a gas stove, the combination with a circular series of burners having converging orifices and adapted to produce flames that are horizontal and that spread laterally without lengthening in the same proportion, said burners occupying radial positions opposite each other and extending their flames toward each other, of a shield or air-shaft surrounding said burners and allowing a current of air to pass transversely through the sheet of flame, substantially as described. 3rd. The employment in a gas stove of hooded burners, such as shown in figures 7 and 8, for the purpose set forth.

No. 58,512. Method of and Apparatus for Testing Plumbing. (Méthode et appareil pour éprouver les ouvrages en plomb.)

Lionel Moses, New York, State of New York, U.S.A., 27th December, 1897; 6 years. (Filed 6th December, 1897.)

Claim.—1st. The apparatus for testing plumbing as herein described, the same consisting of a closed chamber, a pneumatic blower located therein, and having an eduction pipe adapted to be connected to the pipes to be tested in combination with means for rotating the blower and a series of trays held in said chamber for containing fume producing chemicals to be forced into the pipes by the blower, substantially as specified. 2nd. The process or method of testing plumbing for the detection of leaks, which consists in the employment of cold fumes produced by volatile chemicals forced by pneumatic pressure into the pipes to be tested for visually locating any leakages therein, substantially as described. 3rd. The process herein described of testing plumbing for leaks which consists in generating at ordinary temperatures a visible chemical vapour in a chamber, and then charging the pipes to be tested with vapour laden air from said chamber by means of an air-forcing device, substantially as described. 4th. The process herein described of testing plumbing for leaks, which consists in mingling in a chamber different invisible chemical vapours to form a visible vapour and than by air pressure

charge the plumbing with said visible vapour, substantially as described. 5th. The process of testing plumbing for leaks which con-

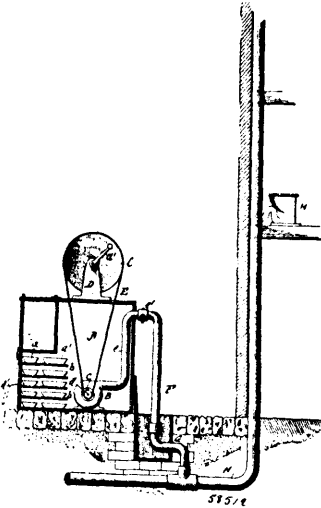

sists in mixing in a closed chamber the gases of ammonia and hydrochloric acid forming a cloud of ammonia chloride and forcing the same under pressure into the plumbing, substantially as described.

No. 58,513. Surgical Splint. (Eclisse de chirurgie.)

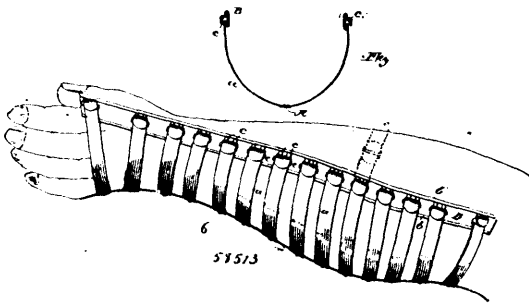

Sidney Herbert Gardiner, Brooklyn, New York, U.S.A., 27th December, 1897; 6 years. (Filed 24th November, 1897.)

Claim.—1st. A new article of manufacture of the class described, consisting of a stiffened or reinforced strip, lateral strips or pieces connected thereto by means of a sliding pivotal connection. 2nd. A article of manufacture of the class described, consisting of a stiffened or reinforced strip, lateral strips or pieces movably attached thereto, and an auxiliary stiffened or reinforced strip connected with said lateral projections by means of a sliding pivotal connection.

No. 58,514. Animal Stall. (Stalle à bestiaux.)

William M. Underhille, Underhill, Wisconsin, U.S.A., 27th December, 1897; 6 years. (Filed 6th December, 1897.)

Claim.—1st. A stall having a pivoted wall adapted when released to swing pivotally to an open position, a beam to lock the wall in its closed position, a bar normally held in one position, and adapted when released to actuate said beam to release the wall, and a latch to hold said bar against movement, substantially as set forth. 2nd. In a stall, the combination of a tilting frame pivoted at its upper part, a locking frame arranged to engage the tilting frame to hold the same in a lowered position, a pivoted bar arranged when released to fall and connected to and adapted to disengage the locking frame from the tilting frame, and a latch to hold said bar against movement, substantially as set forth. 3rd. In a stall, the combination of a pivotally mounted front wall having means to swing it to an open position when released, a beam centrally pivoted on the front wall, keepers at opposite sides of the front wall to be engaged by said beam to lock the front wall in its closed position, a pin guided longitudinally and arranged to engage the beam, a bar normally held raised and adapted when released to strike said pin and swing said beam out of engagement with the keepers, and a latch to hold the bar raised, substantially as set forth. 4th. In a stall the combination of a tilting frame pivoted at its upper part and having side bars formed of pivotally connected sections, means

to hold the tilting frame in a closed position, means to release said frame and permit the same to swing to an open position, and a box

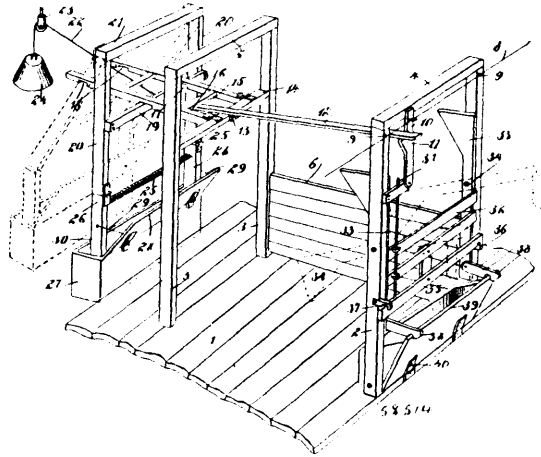

or trough carried on the lower end of the said frame and arranged to stand transversely across the rear part of the stall when said frame is in its lowered position, substantially as set forth. 5th. In a stall, the combination of a tilting frame pivoted at its upper part, means to lock and release said frame, a box carried by the frame and arranged when the frame is lowered to stand transversely across the rear part of the stall, a chute board extending in a forward inclined position from the front of said box, and a netting over the box and chute board, substantially as set forth. 6th. The combination of a box or trough, a chute board hinged at its edge to one edge of the box and adapted to stand in an inclined position, extensions at the ends of the box, and flexible connections between said extensions and the chute board, substantially as set forth. 7th. In a stall, the combination of a tilting frame, pivoted at its upper part and provided with a cross-bar, a locking frame having side bars, means to actuate said locking frame, and notched plates adjustable in the locking frame, to engage said cross-bar of the tilting frame, substantially as set forth. 8th. A stall having a tilting frame and a hinged chute board movable with the tilting frame, the chute board being capable of bearing directly against the animal and of moving independently of the tilting frame by direct contact with the animal, substantially as described. 9th. A stall having a tilting frame pivoted near its upper portion, a trough or box carried by the tilting frame, a chute board hinged to the trough or box, and a flexible connection attached to the chute board and limiting the movement thereof, substantially as described. 10th. A stall having a tilting frame adapted when released to move to an open position, a beam capable of locking the tilting frame in its closed position, a bar capable of movement to actuate the beam to release the frame, and means for actuating the bar, substantially as described. 11th. In a stall, the combination of a tilting frame, means for locking said frame in a closed position, a pivoted wall for the stall, a lock for the wall, and a bar operatively connected to the tilting frame and pivoted wall and capable of movement to simultaneously release the tilting frame and the pivoted wall, substantially as described. 12th. In a stall, the combination of a tilting frame, means tending to raise said frame, a locking device for holding the tilting frame closed, a bar connected to the locking device, a pivoted wall for the stall, the wall having a tendency to open, a locking device for holding the wall in a closed position, and a latch capable of supporting the bar and of permitting the same to simultaneously release each locking device, substantially as described. 13th. In a stall, the combination of a tilting frame having a tendency to rise, means for locking the tilting frame in a closed position, a bar connected with said means and capable of movement to release said frame, a pivoted wall, and means capable of holding said wall in a locked position, the bar being capable of operating the locking means for the front wall and said locking means being capable of operation independent of the bar, substantially as described. 14th. A stall having a pivoted chute board extending transversely at the rear portion of the stall, a receptacle at the rear of the chute board, and flexible connections attached to the chute board and limiting the forward movement thereof, the chute board being adapted to fall forward by its own weight against the animal confined in the stall and being adapted to be forced back by its contact with the said animal to nearly an upright position when the animal pushes or backs against the chute board, substantially as described. 15th. A stall having a hinged chute board, and a flexible connection attached to the free portion of the chute board, the connection being capable of limiting the movement of the chute board and the chute board bearing by gravity against the animal and being moved rearward on its hinge as the animal backs against the chute board, substantially as described. 16th. The combination of a box or trough, a chute board hinged at its edge to one edge of the box and

adapted to stand in an inclined position, an extension at one end of the box and a flexible connection between said extension and the chute board, substantially as described.

No. 58,515. Fan Attachment for Rocking Chairs.

(Attache d'éventail pour fauteuil à bascule.)

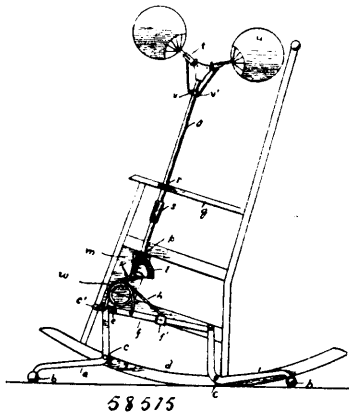

Patrick H. Masterson, Altoona, Pennsylvania, U.S.A., 27th December, 1897; 6 years. (Filed 9th December, 1897.)

Claim.—1st. In a fan attachment for rocking chairs, the combination of the crank-arm, fulcrumed to the rocker, a connecting-bar pivotally engaging at one end to one of the crank-arms and provided with a slot engaging a lug carried by the front crank-arm, a rod pivoted to an adjustable sliding-sleeve, and to a segment engaging a cog-wheel on a rod secured to the side of the chair, and carrying fans on its upper end, substantially as shown and described. 2nd. In a fan attachment the combination of the supporting-rod, carrying the fans, said rod carrying on the lower end a cog-wheel adapted to engage a segment, said segment connected by a pivoted rod to an adjustable sliding-sleeve, carried by the connecting-bar, said connecting-bar pivoted at one end to a crank-arm fulcrumed to the rocker, and provided at the other end with a longitudinal slot engaging a pin carried by the front crank arm, a spiral spring, one end of which is fastened to the connecting-bars, and the other end to the front crank-arm adapted to hold it normally in engagement with the floor during the forward and rearward motion of the chair, and communicating motion to the fans, substantially as shown and described. 3rd. In a fan attachment, the combination of a detachable supporting-rod, carrying on one end an adjustable fan-socket provided with braces engaging an adjustable sliding sleeve carried by said rod, and on the opposite end a sliding sleeve adapted to hold the rod in operative engagement with a rod journalled to the side of the chair, and provided with a cog-wheel, a segment secured to the chair and provided with an arm, said cog-wheel engaging the segment operated by crank-arms, fulcrumed to the rocker and connected by a bar and rod to the arm of the segment, substantially as shown and described.

No. 58,516. Folding Umbrella. (Parapluie.)

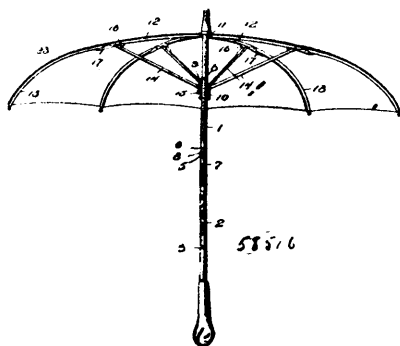

William O. Whitney, Glens Falls, New York, U.S.A., 27th December, 1897; 6 years. (Filed 13th December, 1897.)

Claim.—1st. In a folding umbrella, the combination with the ribs composed of pivoted sections, one each of which has a longitudinal slot at the pivotal joint, of pins applied to each of the other sections and pivotally connecting them with the sections having the longi-

tudinal slots and operating in the latter, whereby the sections of each rib are adapted to have a limited longitudinal movement, hooks on one set of sections, and cross-pins on the opposite sections to be engaged by the said hooks to secure the sections in locked relation, substantially as set forth. 2nd. In a folding umbrella, the combination of a rib composed of two sections, one of the sections having a longitudinal slot at its end, a hook a short distance from the slot, and a spring to extend across the open end of the hook, a pin applied to the terminal of the other section to engage with the said hook, and a pin pivotally connecting the two sections and passing through the aforesaid slot so as to admit of a limited movement of the sections, whereby the said hook can be disengaged from the end of the section in engagement therewith, substantially as set forth. 3rd. In a folding umbrella, the combination of a rib formed of sections, one section having a slot, and a pin applied to the other section and operating in the said slot for pivotally connecting the sections and allowing them to have a limited sliding movement the one upon the other, a stretcher, a pin pivotally connecting the extremity of the lower rib-section with the stretcher, and a hook a short distance from the pivotal end of the upper rib-section to engage with the pin pivotally connecting the stretcher and lower rib-section, substantially as set forth for the purpose described. 4th. In a folding umbrella, the combination of ribs formed in sections which have pivotal connection and a limited play at the pivots, stretchers connected by pins with the upper ends of the lower rib-sections, hooks near the pivotal ends of the upper rib-sections to engage with the pins between the stretchers and the lower rib-sections, and springs 25 arranged so that they will maintain the parts or sections of the-ribs in locked relation, substantially in the manner set forth.

No. 58,517. Caliper. (Compas d'épaisseur.)

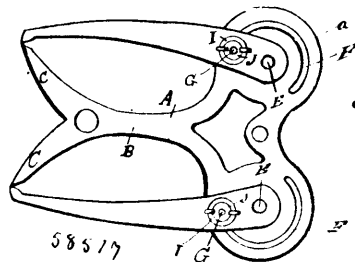

John D. Johnston, Newport, Rhode Island, U.S.A., 27th December, 1897; 6 years. (Filed 16th December, 1897.)

Claim.—The combination, with the body portion, having curved slots and oppositely extending circular portions, and the centrally disposed fixed arm terminating in oppositely disposed points, of the legs pivotally mounted near opposite ends of the body portion and provided with bolts working in said slots, and thumb-nuts on the ends of said bolts, all substantially as and for the purpose specified.

No. 58,518. Fibre Waterproofing Treatment.

(Traitement de fibres à l'épreuve de l'eau.)

Solomon Bennett, Dalston, Middlesex, England, 27th December, 1897; 6 years. (Filed 17th March, 1897.)

Claim.—1st. As new articles of manufacture, fibrous material, as wood, paper, fabrics and fibres saturated with oily liquid and having a strongly adherent partially penetrating coat of nitro-cellulose. 2nd. As new articles of manufacture, fibrous material having a strongly adherent partially penetrating coating of oil and nitro-cellulose. 3rd. The process herein described, which consists in saturating fibrous material with oily liquid and then applying a coating of nitro-cellulose, and causing it to penetrate partially into the material thus saturated.

No. 58,519. Check-Rein Guide. (Guide de fausses-rènes.)

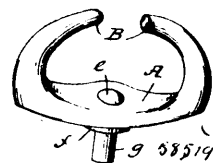

Scott Harter Hull, Oskaloosa, Iowa, U.S.A., 27th December, 1897; 6 years. (Filed 9th December 1897.)

Claim.—1st. As a new and improved article of manufacture, a check-rein guide loop provided with a tubular attaching rivet formed of malleable metal, substantially as described. 2nd. As a new and improved article of manufacture, a check-rein guide loop compris-

ing a base or body portion formed with a central orifice and two upwardly and inwardly curved arms, and a malleable metal attaching rivet having a boss projecting through said orifice and formed with a head bearing against the upper side of the body portion, a flange or collar bearing against the underside of said body portion, and a tubular shank pendant from said flange or collar, substantially as described.

No. 58,520. Check Rein Guide Loop. (*Bride de guide pour fausses rênes.*)

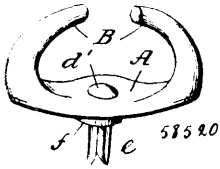

Scott Harter Hull, Oskaloosa, Iowa, U.S.A., 27th December, 1897; 6 years. (Filed 9th December, 1897.)

Claim.—As a new and improved article of manufacture, a check-rein guide loop comprising a base or body portion formed with a central orifice and two upwardly and inwardly curved arms, and a fastening rivet having a boss projecting through said orifice and formed with a head bearing against the upper side of the body portion, a flange or collar bearing against the underside of said body portion, and a split or pronged shank pendant from said flange or collar, substantially as shown and described.

No. 58,521. Rotary Hair Brush. (*Brosse à cheveux.*)

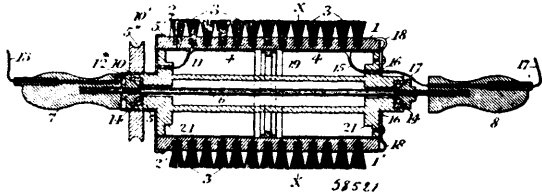

Joseph Riedlinger, Chicago, Illinois, U.S.A., 27th December, 1897; 6 years. (Filed 7th December, 1897.)

Claim.—1st. In a rotary hair-brush, a brushing surface consisting of two brushing parts, separated by a non-conductor of electricity and adapted to pass an electric current through the scalp when both parts are brought in contact therewith, in combination with means for rotating said brush, substantially as described. 2nd. In a rotary hair-brush, a cylindrical brushing surface consisting of two brushing parts, separated by a non-conductor of electricity and adapted to pass an electric current through the scalp when both parts are brought in contact therewith, in combination with means for rotating said brush, substantially as described. 3rd. In a rotary hair-brush, a cylinder having thereon a brushing surface, consisting of two brushing parts, separated by a non-conductor of electricity, and adapted to pass an electric current through the scalp when brought in contact therewith, in combination with a rotary handle on the cylinder with respect to said handle, substantially as described. 4th. In a rotary hair-brush, a cylinder having thereon a brushing surface, consisting of two brushing parts, separated by a non-conductor of electricity and adapted to pass an electric current through the scalp when brought in contact therewith, in combination with a rotary handle at each end of said cylinder, an electric conductor providing a rotary contact between one of said handles and one of said brushing parts, an electric conductor providing a rotary contact between the other handle and the other brushing part, and means for rotating the cylinder with respect to said handles, substantially as described. 5th. In a rotary hair-brush, a frame therefor, having a rotary handle at each end, in combination with a cylindrical brushing surface consisting of two brushing parts, separated by a non-conductor of electricity, and adapted to pass an electric current through the scalp when brought in contact therewith, a catch for removably securing said brushing surface upon the frame, an electric conductor providing a rotary contact between one of said handles, and one of said brushing parts, an electric conductor providing a rotary contact between the other handle and the other brushing part, and means for rotating said frame with respect to said handles, substantially as described. 6th. In a rotary hair-brush, the frame therefor, having a rotary handle at each end, in a combination with a cylinder having thereon a brushing surface and being longitudinally divided into two separable sections, a catch for removably securing said sections upon the frame, and means for rotating said frame with respect to said handles, substantially as described. 7th. In a rotary hair-brush, a frame therefor, having a rotary handle at each end, in combination with a cylinder having thereon a brushing surface, and being

longitudinally divided into two separable sections, a catch for removably securing said sections, upon the frame, said cylinder having therein a conducting lining 4, toward each end, separated by the non-conducting lining 19, and having conducting wires 3, extending from said linings 4, to the surface of the brush, an electric conductor providing a rotary contact between one of said handles and the lining 4, on one side of the lining 19, an electric conductor providing a rotary contact between the other handle and the lining 4, on the other side of the lining 19, and means for rotating said frame with respect to said handles, substantially as described.

No. 58,522. Vegetable Extracts, etc. (*Extrait végétal, etc.*)

Ludwig Fromm, Kotzschbroda, and Rudolf Schmidt, Schlossstrasse, both of Dresden, Germany, 27th December, 1897; 6 years. (Filed 9th December, 1897.)

Claim.—1st. A process for the extraction of fatty and albuminous substances from vegetables containing oil, consisting in finely grinding the vegetable substances and converting the mass into a paste with cold water, in which is dissolved a solvent of albumen, said paste being thoroughly kneaded or mixed, the mass being then converted into an emulsion with water, purified from impurities and reduced to a thick mass by steam heat in a vacuum. 2nd. A process for the extraction of fatty and albuminous substances from vegetables containing oil, consisting in finely grinding the vegetable substances and converting the mass into a paste with cold water, in which is dissolved from 5 to 10 per cent of chloride of sodium, said paste being thoroughly kneaded or mixed, the mass being then converted into an emulsion with water, purified from impurities, and reduced to a thick mass by steam heat in a vacuum. 3rd. A vegetable extract containing vegetable fat or oil and albumen obtained by crushing and grinding vegetable substances containing such oil, forming an emulsion of the mass with water, and cooking the emulsion, substantially as described. 4th. A vegetable extract containing vegetable fat or oil and albumen obtained by crushing and grinding vegetable substances containing such oil, mixing the mass with water containing chloride of sodium only or other solvent of albumen, kneading the mass, and cooking the emulsion, substantially as described.

No. 58,523. Grate. (*Grille.*)

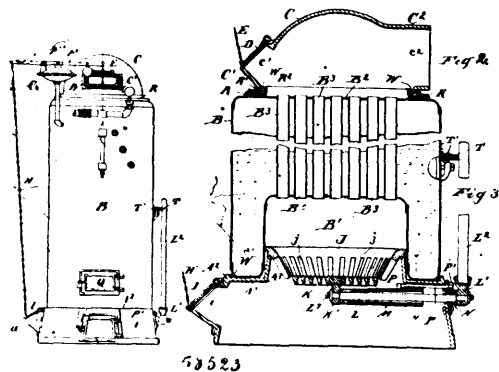

John S. Roake, Brooklyn, New York, U.S.A., 27th December, 1897; 6 years. (Filed 6th December, 1897.)

Claim.—1st. The shaking and dumping grate K, and a suitable stationary rim to enable it to retain fuel and allow its moderate combustion, in combination with a suitable ash-pit and an arm rigidly secured at its outer end to the furnace-base and extending beneath the dumping-grate, together with an operating-shaft parallel with and also supported by said arm and having its inner end connected to the central portion of the grate at its under side, substantially as herein specified. 2nd. The grate K adapted for rocking bodily as shown, a suitable stationary rim, and the tubular grate-support M, and means as the dovetail M¹, cleats A⁴, embracing the latter, bolt P and nut P¹, connecting to the support M for holding and releasing it, in combination with each other and with the rocking shaft L, socket L¹ on such shaft, and handle L² for rocking it, all arranged for joint operation, substantially as herein specified. 3rd. The shaking and dumping grate K, and suitable stationary rim, the grate-support M having an outer dovetailed portion engaging cleats fixed in relation to the base portion, in combination with each other and with the rocking shaft L, and its operating means, substantially as specified. 4th. The shaking and dumping grate K and relatively stationary rim, of a grate-support M, having the outer dovetailed portion, a bolt P, locking the dovetailed portion in engagement with cleats, and securing an outer bearing-piece N, in combination with each other and with a rocking-shaft and its operating means, the shaft bearing both in said support and piece N, substantially as herein specified. 5th. The base-casting A having the

horizontal portion forming a bearing for the boiler-body, and provided with the inner lip or rim A³, supporting the stationary grate K, the grate-support M beneath, and having its outer part secured on the under side of the horizontal portion of the base portion, in combination with each other and with an operating-shaft supported by said support and having its inner end connected to the central portion of the grate, substantially as herein specified.

No. 58,524. Production of Water Gas and Apparatus Therefor. (*Production et appareil de gaz à eau.*)

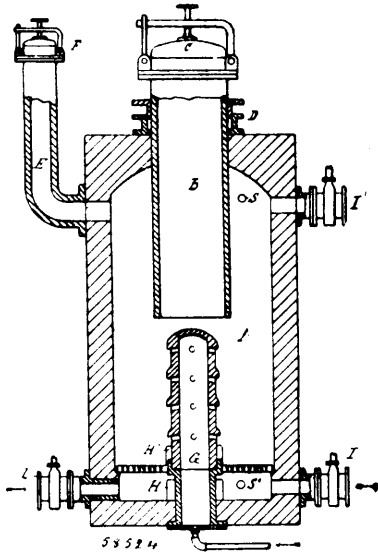

Carl Dellwick, Grefgatan, Stockholm, Sweden, 27th December, 1897; 6 years. (Filed 8th February, 1897.)

Claim.—1st. The process of manufacturing water gas, which consists in admitting steam to the fuel in the generator till its temperature becomes too low to effect the decomposition of the water vapour and in then re-heating the fuel by the admission of a sufficient quantity of air to ensure the products of combustion containing as large a portion possible of carbonic acid gas, the two operations being carried on alternately, substantially as and for the purpose specified. 2nd. An apparatus for the process described in which the height of fuel is automatically maintained constant at a certain level previously determined in accordance with a given supply of air pressure, substantially as described. 3rd. The construction of apparatus for the purpose described, consisting of a generator in combination with a coal, coke, or fuel reservoir B, the lower part of which is capable of vertical adjustment relatively to the bottom of the generator, so that it is possible to determine or regulate the height of the fuel according to the given air supply or pressure, substantially as described. 4th. In a device of the class described, the combination with the generator A, of the coal receptacle B, the air inlet pipe L, with suitable cut-off, the steam inlet pipe S, with suitable cut-off, the water gas outlet pipe I, with suitable cut-off, and the outlet pipe K, for combustion products provided with cover F, substantially as described and specified. 5th. In a device of the class specified, the combination with the generator A, provided with cleaning doors H, H¹, of the adjustable coal receptacle B, provided with cover C, and the stuffing box D, the steam inlet pipes S, S¹, with suitable cut-offs, the water gas outlet pipes I, I¹, with suitable cut-offs, the outlet pipe E, for combustion products provided with cover F, the air inlet pipe L, with suitable cut-off, and the pipe G, provided with air nozzles, substantially as described and specified.

No. 58,525. Machine for Applying Stiffening Compound to Hat Bodies. (*Composé pour raidir les chapeaux.*)

Lewis R. Heim, Danbury, Connecticut, U.S.A., 27th December, 1897; 6 years. (Filed 6th December, 1897.)

Claim.—1st. In a machine for stiffening the brims of hats, the combination of means for conducting and applying the stiffening, a pair of rolls between which the hat is passed, devices for supporting the hat and for properly presenting the same to said rolls, means for revolving the rolls, automatically controlled mechanism for stopping the rotation of the rolls, and instrumentalities automatically controlled and operated by said stop mechanism for separating the rolls immediately prior to the stopping of the rotation thereof, substantially as set forth. 2nd. In a machine for stiffening the brims of hats, the combination of the slide which carries the hat supporting devices and one of the rolls, the power driving mechanism,

automatic means for stopping the machine and instrumentalities automatically controlled and operated by the stop mechanism for

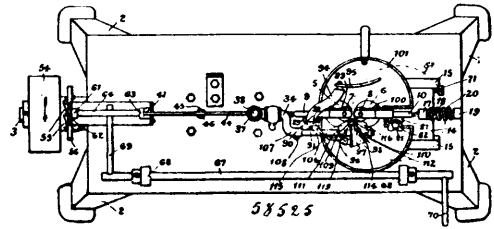

retracting said slide at a predetermined time, substantially as set forth. 3rd. In a machine for stiffening the brims of hats, the combination of the slide supported on the bed of the machine, the pair of rolls one of which is supported within a stationary part of the machine while the other one is supported by said slide, the hat-supporting devices carried by said slide; means, as a spring, for throwing said rolls and devices in normal position, means for revolving the rolls, automatically operated mechanism for stopping the rotation of the rolls, and the slide bar intermediate of said slide and stop mechanism and automatically operated by the latter to retract said slide and the parts carried thereby at a predetermined time, substantially as set forth. 4th. The combination of the power shaft, the slide supported on the bed of the machine, the shafts supported respectively by the stationary bed of the machine and by said slide, the rolls secured on the upper ends of said shafts, the bevel gears on the lower ends of said shafts, the bevel gears on the power shaft meshing with the first named gears, one of these power shaft gears being capable of sliding on its shaft, means for connecting this sliding gear to said slide, the hat-supporting devices carried by said slide, means for revolving the power shaft, stop mechanism for arresting the movement of said shaft, a rotary cam for operating said stop mechanism, a spring for maintaining the normal position of said slide and the parts carried thereby, the slide bar supported beneath the bed of the machine and abutted at one end against said slide, and means carried by said cam and operating against the other end of said bar to throw back the same and thereby effect the retraction of the slides and the parts carried thereby at a time prior to the stopping of the power shaft, substantially as set forth. 5th. In a machine for stiffening the brims of hats, the combination of the rolls between which the hat is passed with devices for supporting the hat and for presenting the inner edge of the hat body to said rolls in a vertical plane, and means for adjusting said devices in different horizontal planes without disturbing the vertical position of said edge, substantially as set forth. 6th. The combination of the rolls between which the hat is passed, with hat supporting devices and means for adjusting the latter in different horizontal planes and for presenting the inner edge of the hat body to said rolls in a fixed vertical plane, substantially as set forth. 7th. The combination of the slide, the bracket carried thereby, the vertically disposed guide-plate secured to said bracket, the bar guided and capable of sliding within said plate, and having an angular bent portion projecting from the upper part thereof, the tip block supported on the extremity of such bent portion, and means for adjusting said bar in different horizontal planes, substantially as set forth. 8th. In a machine for stiffening the brims of hats, the combination with means for supporting the hat body and the rolls between which the hat is passed, of the vertically adjustable bracket 96, having secured thereto the horizontal ledge for supporting the lower edge of the hat body, the outer edge of such ledge being bent and curved and adapted to extend within the hat body, whereby the latter is properly guided between said rolls, substantially as set forth. 9th. The combination of the rolls journaled within the brackets 9, 10, of the scrapers secured to the upper extremity of said brackets and extending in close proximity to the tops of the rolls, the extremities of such scrapers being bent and curved in opposite directions, substantially as set forth. 10th. In a machine for stiffening the brims of hats, and in which the hat is passed between vertically disposed rolls, the drip pan secured in position below such rolls, and provided with perforated upwardly extending thimbles through which the shafts of said rolls pass, and the sheds secured to the bottom of said rolls and overhanging said thimbles, substantially as set forth. 11th. In a machine for stiffening the brims of hats, the combination of the rolls, means for properly supporting the hat and for presenting the same between said rolls, and means for locally applying the stiffening compound to the hat at different points with respect to such rolls, substantially as set forth. 12th. In a machine for stiffening the brims of hats, the combination of the rolls between which the hat is passed, means for properly supporting and presenting the hat between said rolls, the pipes provided with suitable nozzles for applying the stiffening to said hat, and means for adjusting said pipes toward and away from said rolls whereby the stiffening may be applied to said hat at points variably distant from said rolls, substantially as set forth. 13th. The combination of the brackets, the rolls supported therein, devices for supporting the hat and for presenting the same between said rolls, the vertically disposed pipe through which the stiffening

is led, the horizontally disposed pipe connected to said vertical pipe by a roling joint, the vertical pipes leading from said horizontal pipe and provided at their upper extremities with nozzles which extend laterally toward each other, and means whereby said nozzles may be adjusted toward or away from said rolls, substantially as set forth. 14th. In a machine for stiffening the brims of hats, the combination of a pair of rolls for acting upon the hat after the stiffening is applied, means for supporting the hat with its inner edge in a fixed vertical plane, means for adjusting such support to different horizontal planes without disturbing said vertical plane, devices for applying the stiffening to said hat, means for adjusting said devices toward or away from said rolls, the combined support for the lower edge of the hat and curved guide for the inside of the hat, means for imparting revolution to said rolls, automatically operated appliances for stopping the machine at predetermined times, and devices controlled and operated by said appliances for separating the rolls immediately prior to the stopping of the machine, substantially as set forth.

No. 58,526. Trolley. (Trollée.)

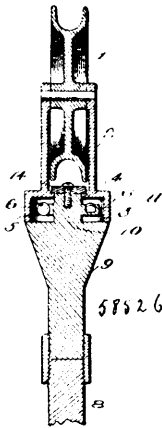

Thomas P. Danton and William Albert Ramey, both of Buffalo, New York, U.S.A., 27th December, 1897; 6 years. (Filed 5th July, 1897.)

Claim.—1st. In a trolley device, the combination of a trolley-wheel bearing having a base with recesses therein, springs mounted in said recesses, and a trolley pole having a head with a spindle provided with a cross-arm to engage the said springs, substantially as and for the purposes specified. 2nd. In a trolley device, the combination of a trolley-wheel bearing having a base with an opening therein and recesses on opposite sides of the opening, coiled springs mounted in said recesses, a trolley pole having a head with a spindle extending therefrom, and a cross-arm in said spindle having slots therein and adapted to engage the said spring in the base of the trolley bearing, substantially as and for the purpose specified. 3rd. In a trolley device, the combination with a trolley-wheel bearing having a base with yielding devices therein, and a trolley pole having a head with a cross-arm to movably engage the said yielding devices, whereby a limited rotation of the base of the trolley-wheel bearing is permitted in either direction, substantially as and for the purposes specified.

No. 58,527. Apparatus for the Treatment of Sewage, etc. (Appareil pour le traitement des égouts, etc.)

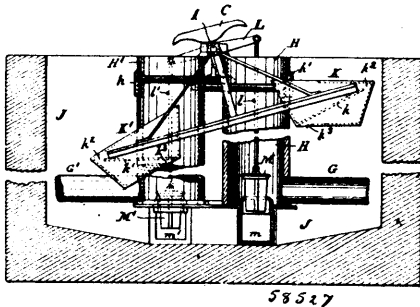

Donald Cameron, No. 1 Sylvan Road, Pennsylvania, Frederick James Commin, 7 Bedford Circus, and Arthur John Martin, Bradninch House, all of Exeter, England, 27th December, 1897; 6 years. (Filed 4th March, 1897.)

Claim.—1st. The improved apparatus for automatically delivering liquid successively to two or more chambers or receptacles and also

discharging it therefrom, consisting in the employment of a pair or pairs of buckets mounted upon a frame or otherwise carried by a shaft or shafts and to which buckets the overflow from one or other of the chambers or receptacles is alternately delivered, the movement thus imparted to such shaft upon which such buckets are mounted being employed to control the valves whereby the supply of liquid to or from the chambers or receptacles is effected, all substantially as specified. 2nd. The combination with the arrangement specified, of a chamber or receptacle, the overflow from which can be connected at will to the alternating or distributing gear in place of one or other of the other chambers or receptacles which are previously in operation, substantially as specified. 3rd. The improved apparatus for automatically delivering liquid successively to two chambers or receptacles and also discharging it therefrom, consisting in the employment of a pair of buckets mounted upon a frame carried by a shaft and to which buckets the overflow from one or other of the chambers or receptacles is alternately delivered, the movement thus imparted to such shaft upon which such buckets are mounted being employed to control the discharge from such chambers or receptacles in succession, and such shaft also carrying a diverter whereby the liquid is alternately delivered to the other chamber or receptacle as soon as one of same is filled, substantially as specified. 4th. The combination with two or more chambers or receptacles into which liquid is successively delivered and from which it is successively discharged, of pipes or passages through which when each chamber is filled a portion of its contents shall overflow for the purpose of effecting the discharge of the contents of a full chamber and the filling of an empty chamber. 5th. The combination with two or more chambers or receptacles and overflow pipes or passages therefrom, of valves or stop-cocks on such overflow pipes which are alternately opened and closed by the motion of the actuating buckets, substantially as described. 6th. The combination with the improved apparatus, of four-way cocks fitted to the overflows from each pair of filters so that any one pair of such filters may be thrown out of operation at will, substantially as specified. 7th. The combination with an actuating bucket as already described, of a counterweight to hold such bucket in a desired position, such counterweight consisting preferably of a second chamber having an opening whereby water may pass into it from the actuating bucket when the latter fills, and a second opening whereby such second chamber may be emptied when it rises, substantially as specified. 8th. The improved apparatus whereby the supply to and discharge from any number of chambers may be controlled by a single pair of buckets actuated either in combination or not, with suitable means for cutting out of or introducing into operation one of such chambers or receptacles, substantially as described. 9th. The combination of overflows from several receptacles or chambers with a disc valve and flap valves by directing the discharge of the overflow from any one of a number of receptacles or chambers into the actuating bucket which should next receive it, substantially as specified. 10th. The arrangement for storing liquid in a chamber or receptacle and suddenly discharging it therefrom, consisting in a bucket or vessel mounted on a lever or shaft connected with a valve in such chamber or receptacle, the overflow from which passes into the bucket or vessel and causes same to descend, thus opening the discharge valve thereof, the bucket or vessel on its descent automatically discharging itself so as to permit same to rise again and thus close the discharge valve of the storage or chamber receptacle, substantially as described. 11th. The employment of a water-wheel actuated by the flow of liquid and which operates a shaft connected to a series of valves delivering liquid to a filter or filters so that such valves will be opened in any desired rotation and thus ensure a uniform distribution of such liquid to all parts of the filter, or a uniform distribution to two or more filters, substantially as described. 12th. The arrangement for delivering liquid in succession to a series of chambers or receptacles or effecting a uniform distribution of same to all parts of a chamber or receptacle, consisting in the employment of a waterwheel actuated by the flow of liquid and the movement of which is transmitted to a revolving basin to which the liquid to be distributed is delivered, so as to bring the discharge orifice of such revolving basin successively opposite a series of channels or passages leading to the different chambers or receptacles or to different parts of a single chamber or receptacle, substantially as described.

No. 58,528. Adjustable Support for Window Shades. (Support pour écrans de fenêtre.)

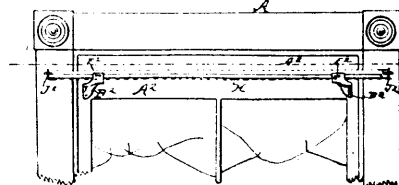

William H. Bisbee, Des Moines, Iowa, U.S.A., 27th December, 1897; 6 years. (Filed 9th August, 1897.)

Claim.—The extensible bracket comprising the part of member B having a right angled perforated extension B², flanges at its edges, and a longitudinal slot having an enlargement at one end, a mating member F having a longitudinal slot and hook-shaped projection to enter and traverse the slot in the other member, and a right angled extension F², at its free end adapted to support a cross-piece, and provided with a slot and cross-piece H fitted to said right angled extension, and slidingly connected therewith by means of a screw extended through said slot, a sleeve J fitted to the end of the cross-piece, and an elbow-shaped roller bearer J² fitted in said sleeve, and provided with a slot J³, and slidingly connected with the cross-piece H by means of a screw, all arranged and combined to operate in the manner set forth for the purposes stated.

No. 58,529. Electric Photographic Time and Position Recorder Specially Useful for Races.
(Photographie électrique de registre horaire à l'usage des courses.)

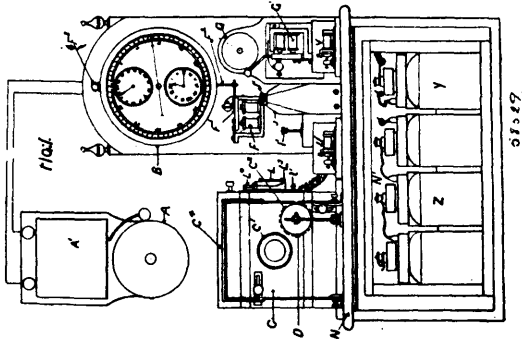

Joseph Gaut, Renwick street, Leichhardt, New South Wales, 27th December, 1897; 6 years. (Filed 25th January, 1897.)

Claim.—1st. An improved electric photographic time and position recorder, specially useful for races, in which synchronously a chrono-

graph is stopped and a photographic plate or film is exposed upon the breakage of a thread stretched across a course or arena, substantially as herein described and explained. 2nd. An improved electric photographic time and position recorder, specially useful for races, in which a chronograph is operated and bells rung synchronously upon the starting of a race and upon the completion of said race, said chronograph is again operated synchronously with the exposure of a photograph plate or film, substantially as herein described and explained. 3rd. An improved electric photographic time and position recorder, specially useful for races, in which a photographic plate or film is exposed under two lenses, one casting upon said plate an image of a reflection of a chronograph, substantially as herein described and as illustrated in the drawings. 4th. In a recorder of the class set forth the combination and arrangement with a chronograph such as B, a camera such as C containing within it a subsidiary camera and having two lenses such as C¹ and C², of an adjustable reflector or mirror such as D in front of one said lens adapted to throw the image of a reflection of said chronograph on to a plate or film exposed in said camera, substantially as herein described and explained and as illustrated in the drawings. 5th. In a recorder of the class set forth the combination and arrangement with a camera such as C having a focal plane shutter operated by a pawl or lever such as L⁶, of an electro-magnet such as L with armature such as L³ and lever such as L⁴, with a bend or return such as L⁵, substantially as herein described and explained and as illustrated in the drawings. 6th. In a recorder of the class set forth, the combination and arrangement with electrical conductors of support such as J adapted to be held upright by a thread in tension and having a chopper terminal such as J³ and a gutter terminal such as K³ adapted to receive terminal such as J⁵ on the break of said tensioned thread and the falling of said support such as J, substantially as herein described and explained and as illustrated in the drawings. 7th. In a recorder of the class set forth, the combination and arrangement with a support such as J adapted to be held upright by a thread in tension, and a hinged piece such as J⁴ adapted to be supported by said support J and upon falling of said support J to contract the bulb of a pneumatic tube in connection with the instantaneous shutter of a camera substantially as herein described and explained and as illustrated in the drawings. 8th. The combination and arrangement of mechanical and electrical parts all together forming an improved electric photographic time and position recorder specially useful for races, substantially as herein described and explained and as illustrated in the drawings.

TRADE-MARKS

Registered during the month of December, 1897, at the Department of Agriculture--
Copyright and Trade-Mark Branch.

6270. JOHN JAMES LAMB, Omemeo, Ont. Harness Leather, 2nd December, 1897.
6271. THE WILKINSON PLOUGH COMPANY, LIMITED, Toronto Junction, Ont. Ploughs, accessories and parts thereof, 2nd December, 1897.
6272. LEOPOLD MILLER & SONS, New York, N. Y., U.S.A. Paper cigarettes, all tobacco cigarettes, cigars, cheroots and stogies, and all kinds of tobacco, manufactured or raw, 2nd December, 1897.
6273. LOUIS LANDREVILLE, Ste. Hélène, Qué. Un remède pour guérir les maladies de rognon, et autres affections analogues, 3 décembre 1897.
6274. A. E. LITTLE & COMPANY, Lynn, Massachusetts, U.S.A. Boots and shoes, 6th December, 1897.
6275. AERATORS LIMITED, London, England. Bottles, cups and similar vessels of metal, bottle stoppers and vessels of porcelain and earthenware, drinking flasks, their cups and stoppers, glass, and capsules for containing gases, 9th December, 1897.
6276. MADAME DAVIES, Toronto, Ont. Medicinal Compounds, 10th December, 1897.
6277. S. DAVIS & SONS, Montreal, Que. Cigars, Cigarettes and Tobaccos, 10th December, 1897.
6278. JOB COOK & GEORGE MARLOTT RYCKMANN, London and Hamilton, respectively, Ont. Hair Producer, 10th December, 1897.
6279. The N. K. FAIRBANK COMPANY, Chicago, Illinois, U.S.A. Soap, 11th December, 1897.
6280. WILLIAM GEORGE NIXEY, 12 Soho Square, London, England. Black Lead, Blue and Knife Polish, 13th December, 1897.
6281. WM. J. FLEMING & JAS. H. FLEMING, St. George, Ont. Fleming's Lump Jaw Cure for Cattle, 15th December, 1897.
- 6282 } CHARLES RICHARD VALENTINE, Whitcliffe, Grove Park, Lee,
6283 } Kent, England. Substances used as food, or as ingredients in
6284 } Food, such as Extract of Meat, Poultry, Fish, Soups, Cream and other Dairy Produces, 17th December, 1897.
6285. HENRY WADE, Kingston, Ont. Dr. Hall's Rheumatic Cure, 20th December, 1897.
6286. THE GUTTA PERCHA AND RUBBER MANUFACTURING COMPANY OF TORONTO, LIMITED, Toronto, Ont. Certain named articles in which India-Rubber or Gutta Percha is a component part, 20th December, 1897.
6287. THE GILL SOAP COMPANY, LIMITED, Tilsonburg, Ont. Soap, 21st December, 1897.
6288. DAISY LIMITED, Holbeck, Leeds, York County, England. Medicinal Powder for the cure of Headache, 21st December, 1897.
6289. E. F. WALTER & COMPANY, Montreal, Que. Cutlery, Knives, Scissors, Razors, Spoons, Skates and the like, 21st December, 1897.
6290. EDWARD D. MACPHERSON AND JOHN K. MACPHERSON, Fingal, Ont., trading as MACPHERSON & COMPANY. Grain Threshing Machines, 24th December, 1897.
6291. THE GUTTA PERCHA AND RUBBER MANUFACTURING COMPANY OF TORONTO, LIMITED, Toronto, Ont. Certain named articles in which India-Rubber or Gutta Percha is a component part, 27th December, 1897.
6292. FRANK H. WRAY, Chicago, Illinois, U.S.A. A Fluid for the Cure of Ruptures, 27th December, 1897.
6293. THE TRURO KNITTING MILLS COMPANY, Truro, N.S. Undergarments, 27th December, 1897.
6294. THE VELVRIL COMPANY, LIMITED, 139 Queen Victoria Street, London, England. General Trade Mark, 27th December, 1897.
6295. HENRY RICHMOND KEYES, Midway, Man. Farm Implements, 28th December, 1897.

-
6296. R. WALKER & SONS, Leicester, England. Knitted Articles of Clothing, 28th December, 1897.
- 297 L'INSTITUT PASTEUR, Paris, France. Serum Anti-diphthérique, 31 décembre 1897.
6298. B. HOUDE & COMPAGNIE, Québec, Qué. Tabac coupé, plug et cigarettes mis en paquet, 31 décembre 1897.
6299. HENRY M. HEYMANN, New York, N.Y., U.S.A. Medicinal preparations for external and internal use, 31st December, 1897.
6300. FELIX HOERENS, St. François de Beauce, Qué. Sucre d'érable raffiné, 31 décembre 1897.
6301. GEORGE T. SLATER & SONS, Montreal, Que. Leather, or Boots, Shoes and Slippers, 31st December, 1897.
6302. GEORGE T. SLATER & SONS, Montreal, Que. Shoe Dressing or Polish, 31st December, 1897.

COPYRIGHTS

Entered during the month of December, 1897, at the Department of Agriculture—
Copyright and Trade-Mark Branch.

9587. ACROSS THE SUB-ARCTICS OF CANADA. (A Journey of 3,200 miles by Canoe and Snowshoe through the Barren Lands.) By J. W. Tyrrell, C.E., D.L.S., Hamilton, Ont., 1st December, 1897.
9588. THE LEVÊQUE SYSTEM OF BOOK-KEEPING: DAY-BOOK AND LEDGER COMBINED. Cyrille Levêque, Toronto, Ont., 2nd December, 1897.
9589. MY BEAUTEOUS QUEEN. (Waltz Song.) Words and Music by Herbert Jenner. The Anglo-Canadian Music Publishers' Association (Ltd.), London, England, 2nd December, 1897.
9590. THE ALLIANCE AGENCY. (Circular.) H. Fawcett Hartland, Montreal, Que., 2nd December, 1897.
9591. NOËLS ANCIENS. Par Ernest Myrand. Publié dans le "Propagateur des Bons Livres," Montreal, Que. (Droit Temporaire d'Auteur.) Cadieux et Derome, Montréal, Qué., 2 décembre 1897.
9592. THE SHAREHOLDERS' AND DIRECTORS' MANUAL. (Fifth Edition.) James D. Warde, Toronto, Ont., 3rd December, 1897.
9593. BELCHER'S FARMER'S ALMANACK, 1898. Hezekiah M. McAlpine, Halifax, N.S., 4th December, 1897.
9594. REGISTRE ET JOURNAL D'APPEL POUR LES ÉCOLES DE LA PROVINCE DE QUEBEC. Jos. Ed. Mercier, Lévis, Qué., 6 décembre 1897.
9595. DEAN'S EMBLEMATIC CHART OF THE BRITISH EMPIRE. Harry J. Dean, Montreal, Que., 6th December, 1897.
9596. SESAME AND LILIES. (Three Lectures by John Ruskin.) The W. J. Gage Company (Ltd.), Toronto, Ont., 6th December, 1897.
9597. THE POTTER'S WHEEL. By Ian Maclaren (Rev. John Watson, D.D.) Hodder & Stoughton, London, England, 6th December, 1897.
9598. THE GIRL WITH THE GOLDEN HAIR. Words and Music by Francis Johnson, Toronto, Ont., 7th December, 1897.
9599. ZANY; OR, LAST FIRST. (Game.) By Waputoniska. Wm. Rhind, Westbourne, Man., 7th December, 1897.
9600. EQUIVALENTS OF STERLING OCEAN RATES. The Benallack Lithographing and Printing Company, Montreal, Que., 7th December, 1897.
9601. BEFORE THE COMING OF THE LOYALISTS. By C. Haight. (U. E. Series, No. 1.) W. R. Haight, Toronto, Ont., 9th December, 1897.
9602. THE BETH BOOK. By Sarah Grand. D. Appleton & Co., New York, N.Y., U.S.A., 9th December, 1897.
9603. THE GREAT STONE OF SARDIS. By Frank R. Stockton. Harper & Brothers, New York, N.Y., U.S.A., 9th December, 1897.
9604. THE SCHOOL FOR SAINTS. (Part of the History of the Right Honourable Robert Orange, M.P.) By John Oliver Hobbes. The Copp, Clark Co. (Ltd.), Toronto, Ont., 9th December, 1897.
9605. No. 1 COPY BOOK OF BUSINESS FORMS AND ACCOUNTS FOR SENIOR THIRD BOOK CLASSES. By S. McAllister and J. T. Slater. The Copp, Clark Co. (Ltd.), Toronto, Ont., 9th December, 1897.
9606. THE IDOL'S EYE TWO-STEP. (From the Comic Opera, "The Idol's Eye.") By Victor Herbert. Edward Schuberth & Co., New York, N.Y., U.S.A., and London, England, 9th December, 1897.
9607. FORM OF INSURANCE POLICY *RE* THE PEOPLE'S LIFE INSURANCE COMPANY. Samuel F. Kilgore, Toronto, Ont., 10th December, 1897.
9608. FORM OF INSURANCE POLICY, ENDOWMENT, *RE* THE PEOPLE'S LIFE INSURANCE COMPANY. Samuel F. Kilgore, Toronto, Ont., 10th December, 1897.

9609. AGENT'S RATE BOOK ISSUED BY THE PEOPLE'S LIFE INSURANCE COMPANY. Samuel F. Kilgore, Toronto, Ont., 10th December, 1897.
9610. AGENT'S RATE BOOK, ENDOWMENT, ISSUED BY THE PEOPLE'S LIFE INSURANCE COMPANY. Samuel F. Kilgore, Toronto, Ont., 10th December, 1897.
9611. BETWEEN EARTH AND SKY. (And other Strange Stories of Deliverance.) By Edward William Thomson. William Briggs (Book-Steward of the Methodist Book and Publishing House), Toronto, Ont., 11th December, 1897.
9612. BOOKS : A GUIDE TO GOOD READING. By John Millar, B.A. William Briggs (Book-Steward of the Methodist Book and Publishing House), Toronto, Ont., 11th December, 1897.
9613. THE NE'ER-DO-WHEEL. By Annie S. Swan. William Briggs (Book-Steward of the Methodist Book and Publishing House), Toronto, Ont., 11th December, 1897.
9614. BEREAN BITS. (The Best Bible Game.) The Endeavour Herald Co. Toronto, Ont., 11th December, 1897.
9615. TO LONDON FOR THE JUBILEE. By "Kit." George N. Morang, Toronto, Ont., 11th December, 1897.
9616. THE DEAR SWEET FACE OF MY MOTHER. Words and Music by Henry G. S. Dixon. Arranged by Henry Helsby. With French Translation, "Le Doux Visage de Ma Mère." Lieut.-Colonel Henry G. S. Dixon, Montreal, Que., 11th December, 1897.
9617. THE DELINEATOR. (A Journal of Fashion, Culture and Fine Arts, January, 1898.) The Butterick Publishing Co. (Ltd.), New York, N. Y., U.S.A., 13th December, 1897.
9618. THE GLASS OF FASHION UP TO DATE. (January, 1898.) The Butterick Publishing Co. (Ltd.), New York, N. Y., U.S.A., 13th December, 1897.
9619. METROPOLITAN FASHIONS. (January, 1898.) The Butterick Publishing Co. (Ltd.), New York, N. Y., U.S.A., 13th December, 1897.
9620. THE CHILDREN OF WISDOM. (And other Sermons Preached in Canadian Pulpits.) By the Rev. John de Soyres, M.A., St. John, N.B., 14th December, 1897.
9621. THE ONTARIO LEGAL CHART, 1898. Henry Cartwright, Toronto, Ont., 14th December, 1897.
9622. LES ANGES À NOËL. (Angels at Christmas Time.) Marche Flégante pour piano, par Madame Camille Marengo, Montréal, Qué., 14 décembre 1897.
9623. MUNICIPAL CASH BOOK FOR THE USE OF CITIES. (Authorized by the Ontario Government.) The Queen, represented by the Attorney General of Ontario, 15th December, 1897.
9624. MUNICIPAL CASH BOOK FOR THE USE OF COUNTIES. (Authorized by the Ontario Government.) The Queen, represented by the Attorney General of Ontario, 15th December, 1897.
9625. MUNICIPAL CASH BOOK FOR THE USE OF TOWNSHIPS. (Authorized by the Ontario Government.) The Queen, represented by the Attorney General of Ontario, 15th December, 1897.
9626. MUNICIPAL CASH BOOK FOR THE USE OF TOWNS. (Authorized by the Ontario Government.) The Queen, represented by the Attorney General of Ontario, 15th December, 1897.
9627. MUNICIPAL CASH BOOK FOR THE USE OF VILLAGES. (Authorized by the Ontario Government.) The Queen, represented by the Attorney General of Ontario, 15th December, 1897.
9628. MANUEL DES FAILLITES. (Manual of Insolvency.) Par J. L. Perron, LL.B., et Victor E. Mitchel, B.C.L. C. Théoret, Montréal, Qué., 15 décembre 1897.
9629. WHEN VALMOND CAME TO PONTIAC. (The Story of a Lost Napoleon.) By Gilbert Parker, London, England, 15th December, 1897.
9630. SPANISH JOHN. By William McLennan. Harper & Brothers, New York, N. Y., U.S.A., 15th December, 1897.
9631. HOW A RACE OF PYGMIES WAS FOUND IN NORTH AFRICA AND SPAIN. (And Papers on other Subjects.) By Robert Grant Haliburton, London, England, 15th December, 1897.
9632. A GROUP OF VIEWS OF TORONTO. Samuel Harris, Toronto, Ont., 15th December, 1897.
9633. TO THE SHAM FIGHT. (March and Two-Step, for piano.) By Emile Kraus. W. H. Billing, Toronto, Ont., 15th December, 1897.

9634. APPLICATION FOR REGISTRATION WITH IDENTIFICATION AND PROTECTIVE COMPANY OF CANADA (LIMITED), Montreal. George Isaac Goddard, Montreal, Que., 16th December, 1897.
9635. RULES FOR PLAYING THE GAME OF YUKONITES. Peter John Campbell McKenzie, Toronto, Ont., 16th December, 1897.
9636. MAP OF MINERAL CLAIMS SITUATED ON FIRE MOUNTAIN, NEW WESTMINSTER DISTRICT, B.C. J. Wyatt Vaughan, Vancouver, B.C., 17th December, 1897.
9637. WHISPER THY LOVE TO ME. Words by Ella Dare. Music by E. P. Short. Whaley, Royce & Co., Toronto, Ont., 17th December, 1897.
9638. THE UNNAMED LAKE, AND OTHER POEMS. By Frederic George Scott. William Briggs (Book-Steward of the Methodist Book and Publishing House), Toronto, Ont., 17th December, 1897.
9639. A SKETCH OF THE LIFE AND TIMES OF JUDGE HALIBURTON. Robert Grant Haliburton, Toronto, Ont., 17th December, 1897.
9640. SLATER SHOE-ISM. George T. Slater & Sons, Montreal, Que., 17th December, 1897.
9641. THE CANADIAN MAGAZINE. (October, 1897.) The Ontario Publishing Co. (Ltd.), Toronto, Ont., 20th December, 1897.
9642. THE CANADIAN MAGAZINE. (November, 1897.) The Ontario Publishing Co. (Ltd.), Toronto, Ont., 20th December, 1897.
9643. THE CANADIAN MAGAZINE. (December, 1897.) The Ontario Publishing Co. (Ltd.), Toronto, Ont., 20th December, 1897.
9644. ALL ROUND ROUTE AND PANORAMIC GUIDE OF THE ST. LAWRENCE. International Railway Publishing Co. (Ltd.), Montreal, Que., 20th December, 1897.
9645. BANK DRAFT. John Wallace Nay, Woodstock, Ont., 20th December, 1897.
9646. HISTORY OF THE CIVIL WAR IN THE UNITED STATES, 1860-1865. Scaife's Comparative Synoptical System of History Applied to all Countries. (Chart.) The Comparative Synoptical Chart Co. (Ltd.), Victoria, B.C., 20th December, 1897.
9647. INDEX TO THE SCAIFE CHART OF THE AMERICAN CIVIL WAR, 1860-1865, WITH INTRODUCTORY NOTES. The Comparative Synoptical Chart Co. (Ltd.), Victoria, B.C., 20th December, 1897.
9648. BUCKINGHAM. (Grand Descriptive Jubilee March.) By Archie F. Morash, Lunenburg, N.S., 20th December, 1897.
9649. CANADA: A METRICAL STORY. By Charles Campbell. William Briggs (Book-Steward of the Methodist Book and Publishing House), Toronto, Ont., 21st December, 1897.
9650. AT MINAS BASIN, AND OTHER POEMS. (Second Edition.) Theodore H. Rand, Toronto, Ont., 21st December, 1897.
9651. THE DIVINE SIGNORINA. By Hal. I. Fachs. The Hunter, Rose Co. (Ltd.), Toronto, Ont., 21st December, 1897.
9652. TAMMANY HALL. (March and Two-Step.) By J. Stanton Gladwin. Harry C. Brown, Toronto, Ont., 22nd December, 1897.
9653. TEN BIBLE BOYS. (Game of Cards.) J. L. Nichols & Co., Toronto, Ont., 23rd December, 1887.
9654. NOUVEAU MANUEL COMPLET D'INDUSTRIE LAITIÈRE POUR LA PROVINCE DE QUEBEC. Par Gabriel Henry, B.E.S., etc. Hector A. Proulx, Québec, Qué., 23 décembre 1897.
9655. COMMON ERRORS IN SPEAKING AND WRITING AND HOW TO AVOID THEM. By H. I. Strang, B.A. The Copp, Clark Co. (Ltd.), Toronto, Ont., 24th December, 1897.
9656. ALGEBRAICAL EXERCISES AND EXAMINATION PAPERS. By C. A. Barnes, M.A. The Copp, Clark Co. (Ltd.), Toronto, Ont., 24th December, 1897.
9657. TABLE OF WHIST LEADS. (Photo.) Francis X. Gaudrie, Port Hope, Ont., 24th December, 1897.
9658. BRIEF OUTLINES OF CHRISTIAN DOCTRINE. By Rev. E. H. Dewart, D.D. William Briggs, (Book-Steward of the Methodist Book and Publishing House), Toronto, Ont., 24th December, 1897.
9659. THE BRIDE-ELECT MARCH. By John Philip Sousa. The John Church Co., Cincinnati, Ohio, U.S.A., 24th December, 1897.
9660. THE HISTORY OF CANADA. By Wm. Kingsford, LL.D., F.R.S.C. Volume IX. (1815-1836). Wm. Kingsford, Ottawa, Ont., 24th December, 1897.

9661. MAP OF THE KLONDIKE, CASSIAR AND CARIBOO GOLD FIELDS. John Bothwick Grant, Vancouver, B.C., 27th December, 1897.
9662. TABLE DE CONCORDANCE DU CODE DE PROCÉDURE CIVILE. Par Philibert Baudouin, Montréal, Qué., 27 décembre 1897.
9663. GERBE DU CHRÉTIEN. (Contenant la Messe, les Vêpres, et autres prières suivis du Chemin de la Croix.) Joseph Daoust, Montréal, Qué., 27 décembre 1897.
9664. BERCEUSE. (For Piano.) By F. J. Hatton-Moore. Whaley, Royce & Co., Toronto, Ont., 29th December, 1897.
9665. RÉVERIE. (For Piano.) By F. J. Hatton-Moore. Whaley, Royce & Co., Toronto, Ont., 29th December, 1897.
9666. PETITE VALSE. (For Piano.) By F. J. Hatton-Moore. Whaley, Royce & Co., Toronto, Ont., 29th December, 1897.
9667. GONDOLIER. (For Piano.) By F. J. Hatton-Moore. Whaley, Royce & Co., Toronto, Ont., 29th December, 1897.
9668. A QUIET STROLL. (For Piano.) By F. J. Hatton-Moore. Whaley, Royce & Co., Toronto, Ont., 29th December, 1897.
9669. THE BRITISH COLUMBIA YEAR BOOK, 1897; WITH MAPS, DIAGRAMS AND ILLUSTRATIONS OF BRITISH COLUMBIA AND THE CANADIAN YUKON. By R. E. Gosnell, Victoria, B.C., 29th December, 1897.
9670. THE PEOPLE OF THE LONGHOUSE. By Edward Marion Chadwick. The Church of England Publishing Co. (Ltd.), Toronto, Ont., 29th December, 1897.
9671. INSURANCE PLANS OF BATISCAN, CAP SANTÉ, CHAMPLAIN, COOKSHIRE, DESCHAMBAULT, KINGSLEY FALLS, LES ECUREUILS, LOTBINIÈRE, MAGOG, MASKINONGE, NAPIERVILLE, NICOLET, POINTE AUX TREMBLES (EN BAS), PONT ROUGE, PORTNEUF, ROCK ISLAND, STANBRIDGE EAST, STANSTEAD, SUTTON, ST. CASIMIR, ST. GERMAIN DE GRANTHAM, ST. GREGOIRE, ST. GUILLAUME D'UPTON, ST. JEAN DE CHAILLONS, ST. PIERRE LES BECQUETS AND VICTORIAVILLE, IN QUEBEC. Charles Edward Goad, Montreal, Que., 29th December, 1897.
9672. INSURANCE PLANS OF FRASER RIVER CANNERIES, NEW DENVER, NEW WESTMINSTER, REVELSTOKE, ROSSLAND, SLOCAN CITY, AND WELLINGTON, IN BRITISH COLUMBIA; GRENFELL, INDIAN HEAD, AND WHITE WOOD, IN ASSINIBOIA; AND INNISFAIL, IN ALBERTA. Charles Edward Goad, Montreal, Que., 29th December, 1897.
9673. THE RAINBOW FEATHER. By Fergus Hume. (Story published in the Hamilton "Herald," Hamilton, Ont.) National Press Agency (Ltd.), London, England, 30th December, 1897. (Temporary Copyright.)
9674. CATECHISM OF THE METHODIST CHURCH, CANADA. Wm. Briggs, (Book-Steward of the Methodist Book and Publishing House), Toronto, Ont., 30th December, 1897.
9675. INSURANCE PLANS OF CALEDONIA, CARDINAL, CHESTERVILLE, DELTA, DUNNVILLE, GANANOQUE, GRIMSBY, HUMBERSTON, IROQUOIS, JASPER, LANSDOWNE, MALLORYTOWN, MERRITTON, NEWBORO, NIAGARA FALLS, NORWICH, OTTERVILLE, PAKENHAM, PORTLAND, PRESCOTT, STEVENSVILLE, THOROLD, TOLEDO, WESTPORT, EAST TORONTO, (INCLUDING LITTLE YORK), IN ONTARIO. Charles Edward Goad, Montreal, Que., 30th December, 1897.
9676. CONSTITUTION OF THE CO-OPERATIVE TRADING CO. (Limited.), Hamilton, Ont. Wm. H. Lenfestey, Hamilton, Ont., 30th December, 1897.
9677. PERIODICAL PREMIUM CIRCULAR. Wm. D. Taylor, Toronto, Ont., 30th December, 1897.
9678. PERIODICAL PREMIUM TICKETS. Wm. D. Taylor, Toronto, Ont., 30th December, 1897.
9679. MANUEL DES BIENSÉANCES. Par M. l'Abbé Th. G. Rouleau, Québec Qué., 30 décembre 1897.
9680. TOUCH AND GO POLKA. By Louis Field. The Anglo-Canadian Music Publishers Association (Ltd.), London, England., 31st December, 1897.
9681. THE FUTURE KINGS OF ENGLAND. (Plate.) Toronto Lithographing Co., Toronto, Ont., 31st December, 1897.

9682. ALMANACH DU PEUPLE, ILLUSTRÉ, DE C. O. BEAUCHEMIN ET FILS, 1898, (29^e ANNEE). C. O. Beauchemin et Fils, Montréal, Qué., 31 décembre 1897.
9683. OFFICIAL TELEPHONE DIRECTORY DISTRICT OF WESTERN ONTARIO, DECEMBER, 1897. The Bell Telephone Company of Canada (Ltd.), Montreal, Que., 31st December, 1897.
9684. THE ONTARIO HOCKEY ASSOCIATION : CONSTITUTION, RULES OF COMPETITION AND LAWS OF THE GAME, AS AMENDED 4TH DECEMBER, 1897. A. H. Beaton, Toronto, Ont., Honorary Secretary of, and on behalf of, The Ontario Hockey Association, 31st December, 1897.
9685. THE 1000 PUZZLE. Robert Samuel Padan, Chicago, Illinois, U.S.A., 31st December, 1897.
9686. TIM AND MRS. TIM. A Story for the "Club" and "Society" Man and the "New" Woman. Richard Thomas Lancefield, Hamilton, Ont., 31st December, 1897.
9687. SA GRANDEUR MGR. L. F. LAFLÈCHE, EVÊQUE DES TROIS-RIVIERES. (Portrait lithographié en couleur). L'Hon. G. A. Nantel, Montréal, Qué., 31 décembre 1897.