

The Linde British Refrigerator Co., Ltd.
301 ST. JAMES ST., MONTREAL.
Sole Manufacturers
Cold-Air-Circulation System.

Over 3,200 Machines Sold.
Special Machines for DAIRIES, BUTCHERS, Etc.
WRITE FOR INFORMATION.

THE CANADIAN
JOURNAL OF COMMERCE
FINANCE AND INSURANCE REVIEW.

Vol. 53. No. 6.
NEW SERIES.

MONTREAL, FRIDAY, AUGUST 9, 1901.

M. S. FOLEY,
EDITOR AND PROPRIETOR

McINTYRE SON & Co.,

MONTREAL.

IMPORTERS of DRY GOODS.

DRESS GOODS,
SILKS,
LINENS,
SMALL WARES,
TREFOUSSE KID GLOVES,
ROUILLON KID GLOVES.

13 VICTORIA SQUARE.

McArthur, Corneille & Co.

310 to 316 St. Paul Street

AND

147 to 151 Commissioners St.,
MONTREAL.

Manufacturers and Importers of

White Lead, Colors,
Glass, Varnishes,
Glues, &c.
Oils, Chemicals, Dyestuffs,
Tanning Materials, &c.

AGENTS FOR . . .

BERLIN ANILINE CO.,
Berlin, Germany.

Manufacturers of Aniline, Colors and
other Coal Tar Products.

JAMES CRISTINE & Co.,

(LTD.)

Manufacturers and Importers of

Hats

Caps

and Furs

MONTREAL.

**Abenakis
Mineral
Water**

TAKEN
FOR
PLEASURE
GIVES
HEALTH.

TAKEN
FOR
HEALTH
GIVES
PLEASURE.

Health and Pleasure
bottled together. A re-
cognized specific for all
diseases of the Stomach,
Kidneys, Blood & Nerves.
A snappy, sparkling NA-
TURAL Mineral Water
of unexcelled flavor. Used
as a table water, there is
no need of medicine to
aid digestion. Bottled at
the Famous Abenakis
Springs, the "Carlsbad
of Canada."

For sale by grocers and druggists.

R. G. KIMPTON, Manager,
Abenakis Springs, P. Q.

Special Agent: **F. LOHMANN,**
346 St. James St., MONTREAL.

The following Brands
Manufactured by . . .
THE American Tobacco Co.
OF CANADA, Limited,

Are sold by all the Leading Wholesale
Houses . . .

OUT TOBACCOOS.

Old Chum,
Seal of North Carolina,
Old Gold.

CIGARETTES

Richmond Straight Cut,
Sweet Caporal,
Athlete, Derby.

MARK FISHER SONS
AND COMPANY,

Merchant Tailors and
Woolen Buyers

will find our Stock replete with all the
Latest Novelties selected in the Home
and Foreign Markets.

We have never shown a more extensive
line of . . .

STAPLE WOOLLENS

than we are doing at present.

Our Tailors' Trimming Dep't
is also more than usually complete.

Mark Fisher, Sons & Co.,
VICTORIA SQ., - MONTREAL.

ROOFING AND ASPHALTING

OF EVERY DESCRIPTION.

Metal Cornices, Skylights, &c.,
Cement and Tile Floors,
Cement Washtubs
&c.

CANADIAN AGENTS:

Boston Hot Blast Heating, and Pneu-
matic System of conveying Mill Stock.

GEO. W. REED & CO.,
MONTREAL.

FOR SALE, in Canada (about 5 miles West of
Niagara Falls) in the Garden of the Dominion,
that First-Class Grain, Pasture and Fruit Farm
known as "BEECHLANDS," situated immediately
East of the town of Thorold, and 4½ miles from St.
Catharines, in the Province of Ontario; about ½
mile from P. O., Market, Railway Stations,
Churches, Schools, &c., containing about 90 acres
fertile loam clay; Fishing Stream of Water and
Railway through the place; Partridge Grove at
lower end; Barns, Stables and other Outhouses,
all for \$7,500. Or will sell without large Stone
House and part of Orchard, Grove and Lawn, say 6
acres. The Gothic Stone Lodge-House, at the North
gate is ample for ordinary family. Easy terms of
payment. The place is well adapted for, and pro-
duces Wheat, Oats, Barley, Hay, Clover, Apples,
Grapes, Pears, Peaches, Plums, Cherries, Quinces,
Strawberries, and other small fruits, nearly all of
the finest quality. Or will Lease Farm, Lodge and
Outbuildings (the latter somewhat out of repair),
with privilege of buying. No waste land.
Thorold and St. Catharines have a connecting
electric-tram service running through the manu-
facturing town of Merriton. The steam railway
service to the Falls has been replaced by an elec-
tric railway service. Address the owner, M. S.
FOLEY, Editor and Proprietor of the "Journal
of Commerce," Montreal, Canada.

BLACK DIAMOND
FILE WORKS.

EST. 1863.

INC. 1895.



HIGHEST AWARDS at TWELVE
International Expositions.

SPECIAL PRIZE,
GOLD MEDAL,
AT ATLANTA, 1895.

G. & H. BARNETT COMPANY,
PHILADELPHIA, PA.

The Chartered Banks.

BANK OF MONTREAL.

(ESTABLISHED 1817.)

Incorporated by Act of Parliament.

Capital (all paid up) \$12,000,000.00
 Reserved Fund, - 7,000,000.00
 Undivided Profits, - 510,084 04

HEAD OFFICE: MONTREAL.

BOARD OF DIRECTORS:

Rt. Hon. Lord Strathcona and Mount Royal, G.C.M.G., President.
 Hon. Geo. A. Drummond, Vice-President.
 A. T. Paterson, Esq., Ed. B. Greenshields, Esq.
 Sir Wm. C. Macdonald, R. B. Angus, Esq.
 A. F. Gault, Esq., James Ross, Esq.
 R. G. Reid, Esq.

E. S. CLOUSTON, General Manager.

A. Macnider, Chief Inspector and Supt. of Branches.
 W. S. Clouston, Insp. of Branch Returns.
 F. W. Taylor, Asst. Insp. James Aird, Sec.

BRANCHES IN CANADA:

MONTREAL, H. V. Meredith, Manager.
 " West End Branch.
 " Seigneurs St. Branch.
 " Point St. Charles Branch.
 Almonte, Ont. Perth, Ont. Amherst, N.S.
 Belleville, " Peterboro, " Halifax, N.S.
 Brantford, " Picton, " Sydney, N.S.
 Brockville, " Sarnia, " Calgary, Alta.
 Chatham, " Stratford, " Lethbridge, Alta.
 Cornwall, " St. Mary's, " Regina, Ass'a.
 Deseronto, " Toronto, " Winnipeg, Man.
 Ft. William, " Yonge st. br. Greenwood, B.C.
 Goderich, " Wallaceburg, " Nelson, B. C.
 Guelph, " Montreal, Que. New Denver, B.C.
 Hamilton, " Quebec, " New Westmins.
 Kingston, " Chatham, N.B. ter, B.C.
 Lindsay, " Fredericton, N.B. Rossland, B.C.
 London, " Moncton, N.B. Vancouver, B. C.
 Ottawa, " St. John, N.B. Vernon, " Victoria, "

IN NEWFOUNDLAND:

St. John's, Nfld., Bank of Montreal.

IN GREAT BRITAIN:

London, Bank of Montreal, 22 Abchurch Lane, E.C.
 Alex. Lang, Man.

IN THE UNITED STATES:

New York—R. Y. Hebden and J. M. Greata,
 Agents, 59 Wall Street.
 Chicago—Bank of Montreal, J. W. de C. O'Grady,
 manager.

BANKERS IN GREAT BRITAIN:

London—The Bank of England.
 " The Union Bank of London.
 " The London and Westminster Bank.
 " The National Provincial Bank of England.
 Liverpool—The Bank of Liverpool, Ltd.
 Scotland—The British Linen Company and
 Branches.

BANKERS IN THE UNITED STATES:

New York—The National City Bank.
 " The Bank of New York, N.B.A.
 " National Bank of Commerce in N.Y.
 Boston—The Merchants' National Bank.
 " J. B. Moors & Co.
 Buffalo—The Marine Bank, Buffalo.
 San Francisco—The First National Bank.
 " The Anglo-Californian Bank.
 Montreal, 17th November, 1900.

THE BANK OF TORONTO.

INCORPORATED 1855.

HEAD OFFICE: TORONTO, CANADA.

Paid-up Capital - - - - - \$2,000,000
 Reserve Fund - - - - - 2,000,000

DIRECTORS:

GEORGE GOODERHAM, Esq., President.
 WM. H. BEATTY, Esq., Vice-President.
 Henry Cawthra, Esq., Geo. J. Cook, Esq.,
 Robert Reford, Esq., Charles Stuart, Esq.,
 William George Gooderham, Esq.

DUNCAN COULSON, - General Manager.
 Joseph Henderson, - Inspector.

BRANCHES:

Toronto, Brockville, Peterboro',
 " King St. W. Br. Cobourg, Petrolia,
 Montreal, Collingwood, Port Hope,
 " Pt. St. Charles Copper Cliff, Rossland, B. C.
 Barrie, Gananoque, Stayner,
 London, St. Catharines,
 London East, Wallaceburg.

BANKERS:

London, Eng.—The London City and Midland
 Bank, Ltd.
 New York—National Bank of Commerce.
 Chicago—First National Bank.
 Careful attention given to the collection of Com
 mercial Paper and Securities.

The Chartered Banks.

**THE BANK OF BRITISH
 NORTH AMERICA.**

Established in 1836.

Incorporated by Royal Charter in 1840.

Paid-up Capital, - - - - - £1,000,000 stg.
 Reserve Fund, - - - - - 350,000 stg.
 London Office, - 5 Gracechurch St., E.C.

COURT OF DIRECTORS:

J. H. Brodie, Ed. Arthur Hoare,
 John James Cater, H. J. B. Kendall,
 Gaspard Farrer, Frederic Lubbock,
 Richard H. Glyn, George D. Whatman,
 Henry R. Farrer,

Secretary A. G. Walls.

Head Office in Canada, St. James street,
 Montreal.

H. STIKEMAN, General Manager.
 J. ELMSLY, Inspector.

BRANCHES IN CANADA:

London, Ont., Quebec, Brandon,
 Brantford, Halifax, N.S., Ashcroft, B. C.
 Hamilton, Sydney, C.B., Atlin,
 Toronto, St. John, N.B., Greenwood,
 Kingston, Fredericton, Victoria,
 Midland, Yukon District, Vancouver,
 Ottawa, Dawson City, Rossland,
 Montreal, Que., Winnipeg, Man. Kaslo.

DRAFTS ON SOUTH AFRICA MAY BE OB-
 TAINED AT THE BANK'S BRANCHES.
 Agents in the United States.

New York (52 Wall St.)—W. Lawson and J. C.
 Welsh, Agents.

San Francisco (127 Sansome Street)—H. M. J.
 McMichael and J. R. Ambrose, Agents.

London Bankers—The Bank of England and
 Messrs. Glyn & Co.

Foreign Agents—Liverpool—Bank of Liverpool.
 Scotland—National Bank of Scotland, Limited, and
 branches. Ireland—Provincial Bank of Ireland,
 Limited, and branches; National Bank, Limited,
 and branches. Australia—Union Bank of Australia,
 New Zealand—Union Bank of Australia, India,
 China and Japan—Mercantile Bank of India, Limited.
 West Indies—Colonial Bank. Paris—Messrs.
 Marcuard, Krauss et Cie. Lyons—Credit Lyonnais.
 Issue Circular Notes for Travellers, available
 in all parts of the world.

THE MOLSONS BANK

Incorporated by Act of Parliament, 1855.

HEAD OFFICE: MONTREAL.

Paid-up Capital, - - - - - \$2,500,000
 Reserve Fund, - - - - - 2,050,000

BOARD OF DIRECTORS:

Wm. Molson Macpherson, President.
 S. H. Ewing, Vice-President.
 W. M. Ramsay, Samuel Finley, J. P. Cleghorn,
 H. Markland Molson, Lt.-Col. F. C. Henshaw.
 JAMES ELLIOT, General Manager.
 A. D. Durnford, Chief Inspector and Superintendent
 of Branches; W. H. Draper, Inspector.
 H. Lockwood W. W. L. Chipman, Asst. Inspectors.

BRANCHES:

Alvinston, Ont. Meaford, Ont. Sorel, P.Q.
 Aylmer, " Montreal, P.Q. St. Thomas, Ont.
 Montreal, St. Catherine St. Branch.
 Montreal, " Mar' et ar'd Harbour"
 Branch, Jacques Cartier Sq.
 Brockville, " Morrisburg, Ont. Toronto, Ont.
 Calgary, Alberta, " Toronto, Ont.
 Chesterville, Ont. Ottawa, " Trenton, " "
 Clinton, " Owen Sound, " Valleyfield, Que.
 Exeter, " Port Arthur, " Vancouver, B. C.
 Fraserville, Que. Quebec, P.Q., Victoria, B. C.
 Hamilton, Ont. Revelstoke, Victoria, Q.
 Hensall, " Station, B.C. Waterloo, Ont.
 Kingsville, " Ridgetown, Ont. Winnipeg, Man.
 Knowlton, Que. Simcoe, " Woodstock, Ont.
 London, Ont. Smith's Falls, Ont.

AGENTS:

British Columbia—Canadian Bank of Commerce.
 Manitoba and North-West—Imperial Bank of
 Canada.

New Brunswick—Bank of New Brunswick.
 Newfoundland—Bank of Nova Scotia.
 Nova Scotia—Halifax Banking Company, Bank of
 Yarmouth.

Ontario—Canadian Bank of Commerce, Dominion
 Bank, Imperial Bank of Canada.

Prince Edward Island—Merchants Bank of P.E.I.,
 Summerside Bank.

Quebec—Eastern Townships Bank.
 Yukon Territory, Dawson City—Canadian Bank
 of Commerce.

IN EUROPE:

London—Parr's Bank, Ltd.; Messrs. Chaplin;
 Milne, Grenfell & Co., Ltd.

Liverpool—The Bank of Liverpool, Limited.
 Ireland—Munster and Leinster Bank, Ltd.
 France—Societe Generale, Credit Lyonnais.
 Germany—Deutsche Bank.

Belgium, Antwerp—La Banque d'Anvers.
 China and Japan—Hong Kong and Shanghai
 Banking Corporation.

IN UNITED STATES:

New York—Mechanics' National Bank; National
 City Bank; Hanover National Bank; The Morton
 Trust Co. Boston—State National Bank; Kidder,
 Peabody & Co. Philadelphia—Philadelphia National
 Bank; Fourth Street National Bank. Portland,
 Me.—Casco National Bank. Chicago—First Na-
 tional Bank. Cleveland—Commercial National
 Bank. Detroit—State Savings Bank. Buffalo—
 N. Y. National Bank. Milwaukee—Wisconsin Na-
 tional Bank of Milwaukee. Minneapolis—First
 National Bank. Toledo—Second National Bank.
 Butte, Montana—First National Bank. San Fran-
 cisco—Canadian Bank of Commerce. Portland,
 Oregon—Canadian Bank of Commerce. Seattle,
 Wash.—Boston National Bank.

Collections made in all parts of the Dominion
 and returns promptly remitted at lowest rates of
 exchange. Commercial Letters of Credit and Trav-
 ellers' Circular letters issued available in all parts
 of the world. Also "Bank Money Orders" payable
 at all banking points in the Dominion.

The Chartered Banks.

**THE ROYAL BANK
 OF CANADA.**

Capital Paid-up, - - - - - \$2,000,000
 Reserve Fund, - - - - - 1,700,000

BOARD OF DIRECTORS:

Thos. E. Kenny, Esq., President.
 Thomas Ritchie, Esq., Vice-President.
 Wiley Smith, Esq., H. G. Bauld, Esq.,
 Hon. David MacKeen.

HEAD OFFICE: HALIFAX, N.S.

E. L. Pease, General Manager (Office of the Gen-
 eral Manager, Montreal); W. B. Torrance, Sec. and
 Supt. of Branches; W. F. Brock, Inspector.

Antigonish, N.S. Newcastle, N.B.
 Bathurst, N.B. Ottawa, Ont.
 Bridgewater, N.S. Pictou, N.S.
 Charlottetown, P.E.I. Port Hawkesbury, N.S.
 Dorchester, N.B. Rossland, B.C.
 Fredericton, N.B. Sackville, N.B.
 Grand Forks, B.C. St. John, N.B.
 Guysboro, N.S. Shubenacadie, N.S.
 Halifax, N.S. St. John's, Nfld.
 Kingston, N.B. Summerside, P.E.I.
 Londonderry, N.S. Sydney, C.B.
 Louisburg, C.B. Truro, N.S.
 Lunenburg, N.S. Vancouver, B.C.
 Maitland, N.S. Vancouver, East End, B.C.
 Moncton, N.B. Victoria, B.C.
 Montreal, Que. Westmount, P.Q.
 Montreal, West End. Weymouth, N.S.
 Nanaimo, B.C. Woodstock, N.B.
 Nelson, B.C.

Agencies in Havana, Cuba; New York, N.Y.; and
 Republic, Washington.

CORRESPONDENTS:

Great Britain, Bank of Scotland. France, Credit
 Lyonnais. Germany, Deutsche Bank. Spain,
 Credit Lyonnais. China and Japan, Hong Kong
 & Shanghai Banking Corporation. New York, Chase
 National Bank. Boston, National Shawmut Bank.
 Chicago, Illinois Trust and Savings Bank. San
 Francisco, First National Bank. Portland, Ore.,
 First National Bank. Seattle, Washington Na-
 tional Bank. Spokane, Exchange National Bank.
 Collections made at lowest rates and promptly
 remitted for. Telegraphic transfer made and
 drafts issued at current rates.

ST. STEPHEN'S BANK.

Incorporated 1836.

St. Stephen, N.B.

Capital, - - - - - \$200,000
 Reserve, - - - - - 45,000

F. H. TODD, President.
 J. F. GRANT, Cashier.

AGENTS:

London—Messrs. Glynn, Mills, Currie & Co. New
 York—Bank of New York, N.B.A. Boston—Globe
 National Bank. Montreal—Bank of Montreal. St.
 John, N.B.—Bank of Montreal.
 Drafts issued on any branch of the Bank of
 Montreal.

**THE WESTERN BANK
 OF CANADA.**

HEAD OFFICE: OSHAWA, ONT.

Capital Authorized, - - - - - \$1,000,000
 Capital Subscribed, - - - - - 500,000
 Capital Paid-up, - - - - - 401,200
 Reserve, - - - - - 134,000

BOARD OF DIRECTORS:

John Cowan, Esq., President.
 Reuben S. Hamlin, Esq., Vice-President.
 W. F. Cowan, Esq., W. F. Allan, Esq.,
 Robert McIntosh, M.D., J. A. Gibson, Esq.,
 Thomas Patterson, Esq.

T. H. McMillan, Cashier.

BRANCHES—Whitby, Midland, Tilsonburg, New
 Hamburg, Paisley, Penetanguishene, Pickering,
 Port Perry, Ont., Tavistock, Ont.

Drafts on New York and Sterling Exchange bought
 and sold. Deposits received and interest allowed.
 Collections solicited and promptly made.

Correspondents at New York and in Canada—
 Merchants Bank of Canada. London, England—
 Royal Bank of Scotland.

THE ONTARIO BANK.

Capital subscribed - - - - - \$1,500,000.00
 Capital Paid-up - - - - - 1,372,914.17
 Rest - - - - - 350,000.00
 Profit and Loss Account - - - - - 16,998.04

HEAD OFFICE: TORONTO.

DIRECTORS:

G. R. R. Cockburn, Esq., President.
 Donald Mackay, Esq., Vice-President.
 Hon. J. C. Aikins, R. D. Perry, Esq.,
 A. S. Irving, Esq., Hon. R. Harcourt, R. Grass.
 CHARLES MCGILL, General Manager.

BRANCHES:

Alliston, Fort William, Ottawa,
 Aurora, Kingston, Peterboro,
 Bowmansville, Lindsay, Port Arthur,
 Buckingham, Q., Montreal, Sudbury,
 Cornwall, Mount Forest, Tweed,
 Newmarket,
 Toronto: Scott and Wellington Streets,
 Queen and Portland "
 Yonge and Richmond "

AGENTS:

London, Eng.—Parr's Bank, Limited.
 France and Europe—Credit Lyonnais.
 New York—Fourth National Bank and The
 Agents Bank of Montreal.
 Boston—Elliot National Bank.

The Chartered Banks.

THE CANADIAN BANK OF COMMERCE

HEAD OFFICE, TORONTO.
Paid-up Capital, \$8,000,000
Rest, 2,000,000

DIRECTORS:
President. HON. GEO. A. COX
Vice-President. ROBERT KILGOUR, Esq.
W. B. Hamilton, Esq., Jas. Crathern, Esq., John Hoskin, Esq., K.C., LL.D., Matthew Leggat, Esq., J. W. Flavelle, Esq., W. E. H. Massey, Esq., A. Kingman, Esq., B. E. WALKER, General Manager.
J. H. PLUMMER, Ass't General Manager.
A. H. Ireland, Chief Insp'r and Supt. of Branches.

BRANCHES OF THE BANK IN CANADA.

ONTARIO:
Ayr, Dundas, Simcoe
Barrie, Ottawa, Stratford
Belleville, Paris, Strathroy
Berlin, Fort Frances, Toronto
Blenheim, Galt, Peterboro, Toronto Jc.
Brantford, Goderich, Port Perry, Walkerville
Cayuga, Guelph, St. Cath'rins, Walkerville
Chatham, Hamilton, Sarnia, Waterloo
Collingwood, London, St. Ste. Marie, Windsor
Dresden, Orangeville, Seaforth, Woodstock

YUKON DISTRICT:
White Horse.

MANITOBA:
Winnipeg, Dawson.

BRITISH COLUMBIA:
Sandon, Greenwood, Nelson, Westminister, Vancouver
Cranbrook, Kamloops, Nanaimo, Roseland, Victoria, Fernie.

IN GREAT BRITAIN:
London, 60 Lombard St., E.C., S. C. Alexander, Mgr

IN THE UNITED STATES:
New York, San Francisco, Cal.; Portland, Ore.; Seattle, Wash.; Skagway, Alaska.

Bankers in Great Britain:
The Bank of Scotland, London; Lloyds Bank, Limited; Messrs. Smith Payne & Smiths, London.

Correspondents Abroad: France—Credit Lyonnais, Paris; Messrs. Lazard Freres & Cie., Paris; Germany—Deutsche Bank, Holland—Diaconto Maatschappij, Rotterdam; Belgium—J. Mathieu, Brussels; Mexico—Banco de Londres y Fils, Mexico; West Indies—Bank of Nova Scotia, Kingston, Jamaica; Colonial Bank and Branches, Bermuda—Bank of B. muda, Hamilton; South America—British Bank of South America, London and Brazilian Bank, India, China and Japan—Chartered Bank of India, Australia & China; South Africa—Standard Bank of South Africa, Limited; Bank of Africa, Limited; Australia & New Zealand—Union Bank of Australia, Limited; Bank of Australasia, Honolulu—First National Bank of Hawaii, Bishop & Co.

Traders Bank of Canada

(Incorporated by Act of Parliament 1885).
Capital Paid Up, 1,344,420
Reserve Fund, 250,000

Board of Directors:
President. C. D. Warren, Esq.
Vice-President. John Drynan, Esq.
HON. J. R. STRATTON, C. KLOEFFER, Esq. M.P. Toronto.
J. H. BRATTY, Esq., of Thorold.
W. J. SHEPPARD, Waubaushene.

Head Office, Toronto.
General Manager. H. S. STRATHY.
Inspector. J. A. M. ALLEY.

BRANCHES:
Arthur, Ont., Hamilton, Sarnia.
Aylmer, Ingersoll, Sault Ste. Marie.
Burlington, Leamington, Strathroy.
Drayton, Newcastle, St. Mary's.
Dutton, North Bay, Sturgeon Falls.
Elmira, Orillia, Sudbury.
Glencoe, Port Hope, Tilsonburg.
Grand Valley, Ridgeway, Windsor.
Guelph.

BANKERS:
Great Britain—The National Bank of Scotland.
New York—The American Exchange Nat. Bank.
Montreal—The Quebec Bank.

BANQUE D'HOCHELAGA.

Capital Subscribed, \$1,500,000
Capital Paid-up, 1,500,000
Reserve Fund, 750,000

DIRECTORS:
F. X. St. CHARLES, President.
R. BICKERDIKE, M.P.P. Vice-Pres.
Hon. J. D. ROLLAND, J. A. Vaillancourt, Esq., and Alphonse Turcotte, Esq.,
M. J. A. PRENDERGAST, Gen'l Manager
C. A. GIROUX, Assistant Manager
O. E. DORAIS, Inspector

Head Office, Montreal.

BRANCHES—Quebec, P. Q., Vankleek Hill, Ont.
Three Rivers, P. Q.
Joliette, P. Q.
Sorel, P. Q.
Valleyfield, P. Q.
Louisville, P. Q.
Sherbrooke, P. Q.
St. Henri, near Montreal
1393 St. Catherine
1756
2317 Notre Dame
Hochelaga.

CORRESPONDENTS—National Park Bank, Nat'l City Bank, Importers & Traders National Bank, Mchts National Bank, M.M. Ladenburg, Thlmann & Co., M.M. Heidelbach, Ickelhelmer & Co., M.M. Kountze Brothers, New York. Third National Bank, International Trust Co., National Bank of Redemption, National Bank of the Commonwealth, Boston. National Live Stock Bank, Illinois Trust and Savings Bank, Chicago. The Clydesdale Bank (Limited), Credit Lyonnais de Paris, Credit Industriel & Commercial, Eng. Credit Lyonnais, Société Générale, Crédit Industriel & Commercial, Comptoir National d'Escompte de Paris, Paris, France. Générale, Crédit Industriel & Commercial, Comptoir National d'Escompte de Paris, Paris, France. Deutsche Bank, Berlin, Germany. Banque Imp. Royale & Priv. des Pays Autrichiens Vienna, Austria. Banque de Rotterdam, Rotterdam, Holland.

Letters of Credit issued available in all parts of the World.
Interest on deposits allowed in Savings Department.

The Chartered Banks.

BANK OF HAMILTON.

CAPITAL paid up, \$1,995,750
RESERVE FUND, 1,500,000
HEAD OFFICE, HAMILTON.

Directors:
JOHN STUART, President
A. G. RAMSAY, Vice-President
John Proctor, Geo. Rosch, Wm. Gibson,
Hon. A. T. Wood, A. B. Lee, (Toronto.)
J. TURNBULL, Cashier.

AGENCIES:
Palmerston, Hamilton, Plum Coulee, M.
Barton St., Port Elgin,
Hamilton, Man., Port Rowan,
Jarvis, Simcoe,
Listowel, Southampton,
Lucknow, Storewall, M.,
Manitow, Man., Toronto,
Milton, Vancouver, B.C.
Mitchell, Wingham,
Morden, Man., Winkler, Man.
Niagara Falls, Orangeville, Winnipeg, Man.
Hamilton, E. End Owen Sound.

British Correspondents:—National Provincial Bank of England [Ltd.] London.
American Correspondents:—New York—Fourth National Bk. and Hanover National Bk. Boston—International Trust Co. Buffalo—Marine Bank. Chicago—Union National Bank, Detroit—Detroit National Bank. Kansas City—National Bank of Commerce. St. Louis—National Bank of Commerce.

Eastern Townships Bank.

(Established 1859).
Capital Authorized, \$2,000,000
Capital paid up, \$1,742,535
Reserve Fund, 1,050,000

BOARD OF DIRECTORS:
R. W. HENKES, President.
Hon. M. H. COCHRANE, Vice-President.
Israel Wood, J. N. Galer, N. W. Thomas,
G. Stevens, C. H. Kathan, H. B. Brown, K.C., J. S. Mitchell.

HEAD OFFICE, SHERBROOKE, Que.
Wm. FARWELL, General Manager.
Branches: Province of Quebec—Montreal, Waterloo, Cowansville, Rock Island, Coaticook, Richmond, Granby, Huntingdon, Bedford, Magog, St. Hyacinthe, Ormstown. Province of B.C.—Grand Forks, Phoenix.

Agents in Canada, Bank of Montreal and Branches.
Agents in London, Eng., National Bank of Scotland.
Agents in Boston, National Exchange Bank.
Agents in New York, National Park Bank.
Collections made at all accessible points and remitted.

THE DOMINION BANK

Capital, \$2,500,000 Reserve Fund, \$2,500,000

DIRECTORS:
E. B. OSLER, M.P., President.
WILMOT D. MATTHEWS, Vice-President.
Wm. Ince, Timothy Eaton, W. R. Brock, M.P.
A. W. Austin, James J. Foy, K.C., M.P.P.

HEAD OFFICE, TORONTO.
Branches:—Brampton, Belleville, Cobourg, Gravenhurst, Guelph, Huntsville, Lindsay, Napanee, Oshawa, Orillia, Seaforth, Uxbridge, Whitby, Toronto, Queen St. W. cor. Esther; Dundas St., cor. Queen; Spadina Ave. cor. College St.; Sherbourne St., cor. Queen; Market Branch, cor. King and Jarvis Sts.; Montreal, Que.; Winnipeg, Man.
Drafts on all parts of the United States, Great Britain and the Continent of Europe bought and sold.
Letters of Credit issued available in all parts of Europe, China, Japan and the West Indies.

The Standard Bank of Canada

Capital Paid-up, \$1,000,000
Reserve Fund, 750,000
HEAD OFFICE, TORONTO.

DIRECTORS:
W. F. COWAN, President.
JOHN BURNS, Vice-President.
W. F. Allan, Fred. Wyld,
T. R. Wood, Jas. Scott, A. J. Somerville

AGENCIES:
Ailsa Craig, Cannington, Kingston,
Bowmanville, Chatham, Markham,
Brantford, Colborne, Parkdale, Toronto
Bradford, Durham, Picton,
Brighton, Forest, Richmond Hill,
Brussels, Harriston, Stonville.

BANKERS:
Campbellford, New York—Importers and Traders National Bank
Montreal—Can. Bank of Commerce.
London, England—National Bank of Scotland.
All banking business promptly attended to. Correspondence solicited.
GEO. P. REID, General Manager.

THE BANK OF OTTAWA.

Established, 1874
HEAD OFFICE, Ottawa, Canada,
Capital (authorized) \$2,000,000
Rest, 1,665,000

DIRECTORS:
CHARLES MAGEE, President.
GEORGE HAY, Vice-President
Hon. Geo. Bryson, Alex. Fraser, John Mather,
David MacLaren, D. Murphy.

GEO. BURN, Gen. Mgr.—D. M. FINNIE, Ottawa Mgr.
Branches: Ontario—Alexandria, Arnprior, Avonmore, Bracebridge, Carleton Place, Cobden, Hawkesbury, Keewatin, Kemptville, Lanark, Matilda, Ottawa, Wellington street, Bank street, Rideau St., Somerset street, Smith's Falls, Toronto, Vank-Portage, Renfrew, Parry Sound, Pembroke, Rat-leek Hill, Winchester, Quebec.—Granby, Hull, La-chaute, Montreal, Shawinigan Falls, Manitoba—Dauphin, Portage la Prairie, Winnipeg.

The Chartered Banks.

UNION BANK OF CANADA

Capital Paid-up, \$2,000,000
Rest, 550,000
HEAD OFFICE, QUEBEC

Board of Directors:
ANDREW THOMSON, Esq., President.
HON. JOHN SHARPLES, Vice-President.
D. C. Thomson, Esq., E. J. Hale, Esq.
Ed. Giroux, Esq., Wm. Shaw.

Wm. Price, Esq., Gen. Manager
F. W. S. Crispo, Inspector
J. G. Billett, Asst. Inspector

Branches:
Alexandria, Ont. Indian Hd., N.W.T. Pincher Creek, N.W.T.
Boissevain, Man. Killarney, Man. Quebec, Que.
Calgary, N.W.T. Lethbridge, N.W.T. St. Louis St. Carberry, Man. Macleod, N.W.T. Regina, N.W.T.
Carleton Place, O. Manitow, Man. Shelburne, Ont.
Carman, Man. Merrickville, Ont. Smith's Falls, O.
Crystal City, M. Melita, Man. Toronto, Ont.
Deloraine, Man. Minnedosa, Man. Souris, Man.
Edmonton, N.W.T. Montreal, Que. Virton, Man.
Glenboro, Man. Moomsomin, N.W.T. Wawanesa, Man.
Greta, Man. Moose Jaw, N.W.T. Wawanesa, Man.
Hamlet, Man. Morden, Man. Wiarton, Ont.
Hartney, Man. Neepawa, Man. Winchester, Ont.
Hastings, Ont. Norwood, Ont. Winnipeg, Man.
Holland, Man. Yorkton, N.W.T.

Foreign Agents:
London, Parr's Bank, Limited
Liverpool, National Park Bank.
New York, National Bank of Commerce.
Minneapolis, St. Paul National Bank.
St. Paul, First National Bank.
Great Falls, Mont. Commercial National Bank.
Chicago, Ill. The City National Bank.
Buffalo, N. Y. First National Bank.
Detroit, Mich.

THE QUEBEC BANK.

HEAD OFFICE, QUEBEC
Founded 1818. Incorporated 1822.
CAPITAL AUTHORIZED \$3,000,000
PAID-UP 2,500,000
REST 700,000

DIRECTORS:
JOHN BREAKRY, President.
JOHN T. ROSS, Vice-President.
Gaspard Lemoine, W. A. Marsh, Vesey Boswell,
F. Billingsley, C. F. Smith.
THOMAS McDUGALL, Gen. Manager.

Branches:
Quebec, St. Peter St. Thorold, Ont.
do Upper Town. Three Rivers, Que.
do St. Roch. Toronto, Ont.
Montreal, St. James St. Shawenegan Falls, Q.
do St. Catherine St. E. St. George, Beauce, Q.
Ottawa, Ont. St. Henry, Que.
Theftord Mines, Que. Victoriaville, Que.

Agents:
Pembroke Ont. Bank of Scotland.
London, Eng., National Bk. of the Republic.
Boston, Agts. Bk. of Brit. North Amer.
New York, U.S.A. Hanover National Bank.

HALIFAX BANKING CO.

Incorporated 1872.
Capital Paid-Up, \$600,000
Reserve Fund, 475,000
HEAD OFFICE, HALIFAX, N.S.

DIRECTORS:
ROBIN UNLACKE, President.
C. W. ANDERSON, Vice-President.
JOHN MACNAB, W. J. G. THOMSON, W. N. WICKWIRE
H. N. WALLACE, Cashier.
A. ALLAN, Inspector.

BRANCHES—Nova Scotia: Halifax, Amherst, Antigonish, Barrington, Bridgewater, Canning, Lockeport, Lunenburg, Middleton, New Glasgow, Parrsboro, Shelburne, Springhill, Truro, Windsor, New Brunswick: Sackville, St. John.

CORRESPONDENTS—Dominion of Can.—Molson's Bank and Branches, New York—Fourth National Bank, Boston—Suffolk National Bank London, England—Parr's Bank, Limited.

BANK OF NOVA SCOTIA.

INCORPORATED 1832.
Capital Paid-up, \$2,000,000.00
Reserve Fund, 2,600,000.00
Head Office, HALIFAX, N.S.

DIRECTORS:
JOHN Y. PAYKANT, President.
CHARLES ARCHIBALD, Vice-President.
R. L. BORDEN, J. WALTER ALLISON.
GEO. S. CAMPBELL, HECTOR MCINNIS.

General Office, TORONTO, Ont.
H. C. McLEOD, Gen. Manager.
D. WATERS, Chief Insp'r. GEO. SANDERSON, Insp'r.

BRANCHES:
In Nova Scotia—Amherst, Annapolis, Bridgetown, Dartmouth, Digby, Glace Bay, Halifax, Kentville, Liverpool, New Glasgow, North Sydney, Oxford, Pictou, Pugwash, Stellarton, Westville, Yarmouth.
In New Brunswick—Campbellton, Chatham, Fredericton, Moncton, Newcastle, St. John, St. Stephen, St. Andrews (sub. to St. Stephen), Sussex, Woodstock.
In P.E. Island—Charlottetown and Summerside.
In Quebec—Montreal and Paspébiac.
In Ontario—Almonte, Arnprior, Berlin, Ottawa, Toronto.
In Manitoba—Winnipeg.
In Newfoundland—St. John's and Harbor Grace.
In West Indies—Kingston, Jamaica.
In United States.—Boston, Mass.: Calais, Maine.
Chicago, Ill.

The Chartered Banks.

Imperial Bank of Canada.

Capital (paid up) \$2,500,000
 Rest 1,850,000

DIRECTORS.

H. S. HOWLAND, President.
 T. R. MERRITT, Vice-President.
 Wm. Ramsay, Robert Jaffray,
 T. Sutherland Stayner, Elias Rogers, Wm. Hendrie.

HEAD OFFICE, TORONTO.

D. R. WILKIE, General Manager.

BRANCHES IN ONTARIO.

Essex, Listowel, St. Catharines,
 Fergus, Niagara Falls, Sault Ste. Marie
 Galt, Ottawa, St. Thomas,
 Hamilton, Port Colborne, Toronto,
 Ingersoll, Rat Portage, Welland,
 Woodstock.

BRANCH IN QUEBEC.—Montreal.

BRANCHES IN NORTH WEST AND BRITISH COLUMBIA.

Brandon, Man. Prince Albert, Sask.
 Calgary, Alta. Revelstoke, B.C.
 Edmonton, Alta. Strathcona, Alta.
 Golden, B.C. Vancouver, B.C.
 Nelson, B.C. Winnipeg, Man.
 Portage La Prairie, Man.

AGENTS.—London, Eng., Lloyd's Bank, Ltd.,
 New York, Bank of Montreal, Bank of America.
 Sterling exchange bought and sold. Letters of
 Credit issued available in any part of the world.

La Banque Nationale.

HEAD OFFICE, QUEBEC.

Capital Paid-Up, \$1,200,000.00
 Rest, 275,000.00
 Undivided Profits, 54,738.91

DIRECTORS:

R. AUDETTE, Esq., President.
 A. B. Dupuis, Esq., Vice-President
 Hon. Judge Chauveau, V. Chateaufort, Esq.,
 N. Rioux, Esq., N. Fortier, Esq.,
 J. B. Laliberté, Esq.,
 P. LAFRANCE, Manager. N. LAVOIE, Inspector.

Branches:

Quebec, (St. Roch) St. Francois, Beauce, P.Q.
 do (St. Johns St.) St. Marie, do
 Montreal, Chicoutimi, P.Q.,
 Ottawa, Ont., Roberval, P.Q.,
 Sherbrooke, P.Q., St. Hyacinthe, P.Q.,
 Joliette, P.Q., St. Johns, P.Q.,
 Murray Bay, P.Q., Rimouski, P.Q.,
 Montmagny, P.Q., Fraserville, P.Q.,
 St. Casimir, P.Q.,

Agents—England—The National Bank of Scot-
 land, London. France—Credit Lyonnais, Paris and
 Branches. United States—The National Bank of
 the Republic, New York; Shoe and Leather
 National Bank, Boston, Mass.
 Prompt attention given to collections.
 Correspondence respectfully solicited.

Union Bank of Halifax.

INCORPORATED 1856.

Capital Authorized, \$1,500,000
 Capital Paid up, 900,000
 Rest, 505,000

DIRECTORS.

WM. ROBERTSON, Esq., President.
 WM. ROCHE, Esq., M.P., Vice-President.
 C. C. BLACKADAR, Esq., J. H. SYMONS, Esq.
 G. MITCHELL, Esq., M.P.P., E. G. SMITH, Esq.,
 A. E. JONES, Esq.

HEAD OFFICE: HALIFAX, N.S.

E. L. THORNE, Genl. Mgr.,
 C. N. S. STRICKLAND, Inspector.

BRANCHES:

Annapolis, N.S., E. D. Arnaud, Manager.
 Barrington Passage, N.S., C. Robertson,
 Bridgetown, N.S., N. R. Burrows,
 Broad Cove, C.B., J. A. Irving, Act. Mgr.
 Clarke's Harbour, N.S., C. Robertson,
 Dartmouth, N.S., J. P. L. Stewart, Mgr.
 Digby, N.S., J. E. Allen,
 Glace Bay, C.B., J. W. Ryan,
 Granville Ferry, N.S., E. D. Arnaud, Act. Mgr.
 Halifax, N.S., A. D. McRae, Manager.
 Kentville, N.S., W. C. Harvey,
 Lawrencetown, N.S., N. R. Burrows, Act. Mgr.
 Liverpool, N.S., E. R. Mulhall, Mgr.
 Mabou, C.B., J. R. McLean, Act. Mgr.
 New Glasgow, N.S., R. C. Wright, Manager.
 North Sydney, C.B., C. W. Frazer,
 Sherbrooke, N.S., F. O. Robertson,
 Sydney, C.B., H. W. Jublen,
 Sydney Mines, C.B., R. Creighton, Act. Mgr.
 St. Peter's, C.B., A. F. Little, Manager.
 Wolfville, N.S., J. D. Leavitt,

CORRESPONDENTS:

Bank of Toronto and Branches, Canada.
 National Bank of Commerce, New York.
 Merchants' National Bank, Boston.
 London & Westminster Bank, Lt. London, Eng.
 Royal Bank of Canada, St. John's, Nfld.
 Interest allowed on Deposit Receipts and De-
 posits in Savings Bank Department.
 Collections receive immediate attention and
 prompt returns made.

THE

Ward Commercial Agency

Mercantile Reports. Collections.

Personal Attention. Prompt Returns

246 St. James Street, MONTREAL

Attention Given to Special Reporting.

Ocean Steamships.

DOMINION LINE
 . . . Steamships.

LIVERPOOL SERVICE.

FROM PORTLAND.

DOMINION Aug 10th, 9 a.m.
 CAMBROMAN Aug. 17th, 9 a.m.
 *ROMAN Aug. 24th, 9 a.m.
 *OTTOMAN Aug. 31st, 9 a.m.
 VANCOUVER Sept. 7th, 9 a.m.

*These steamers do not carry passengers.

Rates of Passage.

Saloon—\$70.00 and upwards.
 Second Saloon—\$35.00 and \$37.50 according
 to steamer
 Third Class—\$25.00 and \$26.00, according to
 steamer.

FROM BOSTON.

(Via Queenstown)

NEW ENGLAND Aug. 14th
 COMMONWEALTH Aug. 28th
 NEW ENGLAND Sept 11th
 COMMONWEALTH Sept. 25th

Rates of Passage.

Saloon—\$60.00 and upwards.
 Second Saloon—\$40.00 and upwards.
 Third Class—\$28.00 to Liverpool, London
 Londonderry, Belfast and Glasgow.

Midship saloons, electric light, spacious prom-
 enade decks
 For further information apply to any agent of
 the company, or to

DAVID TORRANCE & CO.,

General Agents, Montreal.

17 St. Sacrament Street.

Loan Societies.

BONDS

FOR PERMANENT INVESTMENT.

We have purchased, after careful investi-
 gation, various issues of
**Government, Municipal and
 Corporation Bonds**

which we now offer, to yield from 3 1-2 per
 cent. to 5 1-2 per cent.

Send postcard for full information to

THE CENTRAL CANADA
 Loan & Savings Company,
 TORONTO, CANADA.

The Dominion Savings
 & Investment Society

MASONIC TEMPLE BUILDING,

London, Canada.

Capital Subscribed, \$1,000,000 00
 Total Assets, 31st Dec'br, 1900 2,272,980 88

T. H. PURDOM, Esq., K.C., President.
 NATHANIEL MILLS, Manager.

JAMES MURRAY,

of ST. JOHN'S, Newfoundland,
 GENERAL * COMMISSION * AGENT.

Respectfully solicits trial consignments in the fol-
 lowing lines of goods handled:
 Flour and Breadstuffs, Pork, Beef, and General
 Provisions, Sugar and Molasses, Nova Scotia and
 P.E.I. produce. Canadian products of all kinds,
 Teas, Manufactured Goods, Proprietary Articles,
 Fish, Oil and Newfoundland Products.

Business Founded 1795.

American Bank Note Company.

78 to 86 TRINITY PLACE, NEW YORK.

ENGRAVERS AND PRINTERS OF

Bank Notes, Share Certificates,
 Bonds for Governments and
 Corporations, Drafts, Checks,
 Bills of Exchange,
 Postage and Revenue Stamps
 from Steel Plates.

With Special Safeguards to Prevent Counterfeiting.

JAMES MACDONOUGH, Chairman.
 AUGUSTUS D. SHEPARD, President.
 THEO. H. FREELAND, Vice-Pres. & Treas.
 WARREN L. GREEN, 2nd Vice-Pres.
 JOHN E. CURRIER, Secretary.
 J. K. MYERS, Ass't Treas.
 F. R. MYERS, Ass't

Oceanic Steamships.

ALLAN LINE

MONTREAL TO LIVERPOOL

VIA

QUEBEC, RIMOUSKI, MOVILLE.

ROYAL MAIL SERVICE.

NEW STEAMERS.

Tunisian, 10,575 Tons, Twin Screws.

Bavarian, 10,375 Tons, Twin Screws.

Ionian, 10,000 Tons, Twin Screws.

Australasian, 7,765 Tons, Twin Screws.

These are the largest, finest and
 fastest vessels ever built for the St.
 Lawrence route.

From Liverpool. Steamers. From Montreal.

1 Aug Australasian, 17 Aug., 4 a.m.

8 Aug Pretorian, new, 24 Aug., 9 a.m.

15 Aug Tunisian . . . 30 Aug., 1 p.m.

22 Aug Numidian . . . 7 Sept., 9 a.m.

29 Aug Parisian . . . 14 Sept., 4 a.m.

The Tunisian is the largest, fastest and finest
 steamer ever built for the Canadian route.

The Saloons and Staterooms are in the central
 part where least motion is felt. Electricity is used
 for lighting the ships throughout, the lights being
 at the command of the passengers at any hour of the
 night. Music rooms and smoking room on the
 promenade deck. The Saloons and Staterooms are
 heated by steam.

RATES OF PASSAGE.—Cabin: \$50.00 and up-
 wards. A reduction is made on Round Trip
 Tickets, except on lowest rate.

Second Cabin—To Liverpool, London or Lon-
 donderry. \$35 to \$40 Single, \$68.88 to \$76 Return.

Steerage—To Liverpool, London, Glasgow, Bel-
 fast or Londonderry, including every requisite for
 the voyage, \$26.00.

Glasgow, and New York Service
 calling at Londonderry.

From New Pier foot of W. 21st Street, New York

From Glasgow. From New York.

27 July Laurentian 14 Aug.

10 Aug Sardinian 28 Aug.

17 Aug Mongolian 4 Sept.

Rates: First Cabin, \$45 to \$60 Single,
 \$80 to \$108.00 Return. Second Cabin,
 \$32 50 Single, \$61.75 Return. Steerage to
 Glasgow, Belfast or Londonderry \$26.00.

Outfit for Steerage passengers furnished free.

The Steamers employed on these services are not
 surpassed for accommodation for all classes of
 passengers.

For further information apply to

H. & A. ALLAN,

55 Common St., Montreal.

The ROYAL TRUST CO'Y

... MONTREAL ...

Capital Subscribed, - \$500,000 00
 Capital Paid Up, - \$250,000 00

PRESIDENT.

RIGHT HON. LORD STRATHCONA AND MOUNT
 ROYAL, G.C.M.G.

VICE-PRESIDENT:

HON. GEORGE A. DRUMMOND.

DIRECTORS:

R. B. Angus, Sir William C.
 E. S. Clonston, Macdonald,
 A. F. Gault, A. Macnider,
 E. B. Greenshields, H. V. Meredith,
 C. M. Hays, A. T. Paterson,
 C. R. Hosmer, James Ross,

T. G. Shaughnessy,

Sir William C. Van Horne, K.C.M.G.

Temporary Offices—Savings Department
 Bank of Montreal, St. James Street, Montreal.

Bankers—The Bank of Montreal.

The Company is authorized to act as Trustee,
 Executor, Assignee, etc., to manage estates, to
 countersign and issue bonds, to act as judicial
 surety-security in Appeal, etc., and as Transfer
 Agent and Registrar of Shares; and to accept any
 Financial Agency.

The Company will act as Agent and Attorney
 for executors already acting.

Solicitors and notaries placing business with
 the Company are retained to do the legal work in
 connection with such business.



S. BIRCH & CO.,

BELFAST, Ireland,

Manufacturers of the celebrated

BELFAST GINGER ALE
 and SODA WATER. . .

ULD. PERRAULT

General Binder

Blank Book Maker. Ruling, Paging, Perforating,
 &c. All library books and other sets promptly
 attended to.

40 Place Jacques Cartier, Montreal.

R. HUDSON

Gildersome Foundry, near LEEDS. ENG

Telegrams—
Foundry, Gildersome
& B C Code used

5 Minutes' walk from
Gildersome Station, G.N.
Railway.
Leeds to Bradford via Tingley.

National Telephone
No. 14,
Leeds Exchange.

30 Minutes' walk from Morley Station, L. & N.W. Ry



59—R. H.'s Patent 6-Ton Steel Double Side Tip Wagon, to work with ordinary 14 1/2 Wagons



62—R. H.'s Patent Steel Goods Wagon, with Side Doors

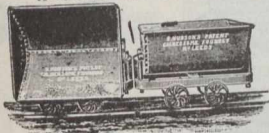

66—R. H.'s Latest Patent V or U-Shaped Double Side Tips. Occupy less room than any other make

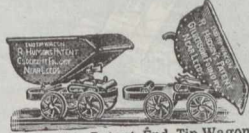

30—R. H.'s Patent End Tip Wagon. Made to any gauge and any capacity.



76—Hand Trolley, made to carry any weight or to suit any rail gauge.



70—R. H.'s Patent Steel Mining Wagon

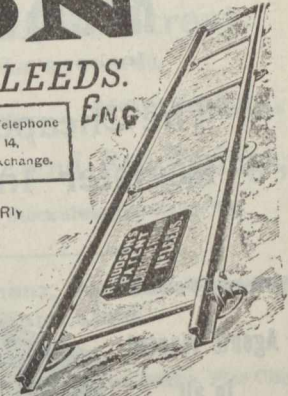

43—R. H.'s Patent Railway. For 90 lbs. Rivets, or Loose Parts. Will last ten times as long as the ordinary kind. Guaranteed strong by satisfactory

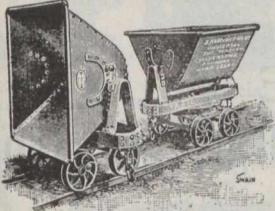

60—R. H.'s Patent Double-Centre Universal Tip Wagon tipping either Endways or Sideways at will

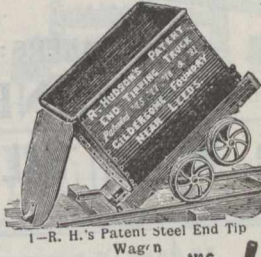

1—R. H.'s Patent Steel End Tip Wagon



40—Turnout, with Fixed Point

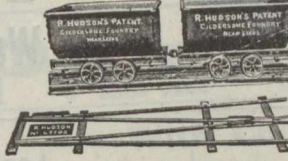

39—Pass-by, with Fixed Points Castings only



17—R. H.'s Patent Self-contained Ball Bearing Turntable, dispensing with Lubrication and Masonry Foundations



27—Hopper Wagon, with Slide Door

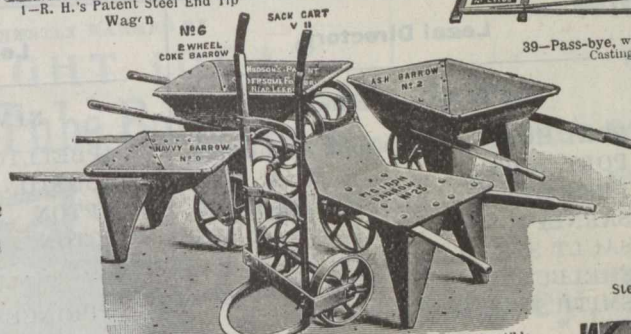

13—R. H.'s Patent Steel Barrows. Practically indestructible

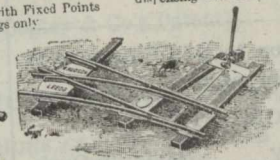

10—Left-hand Steel Points & Crossing



Steamship Barrow. Drawing V 10



67—R. H.'s Improved Steel Ladder. Strong, very light, and durable

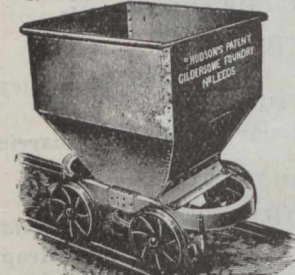

69—R. H.'s Improved Steel Hopper Wagon with Slide Door

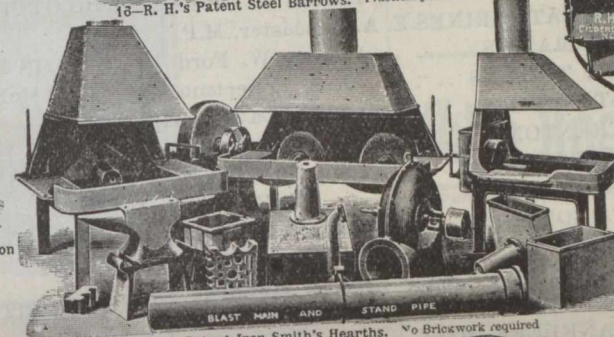

6—R. H.'s Patent Iron Smith's Hearths. No Brickwork required

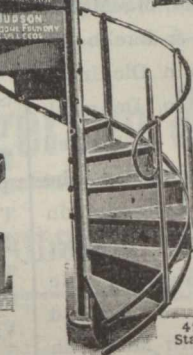

41—R. H.'s Patent Steel Staircases. Extremely light

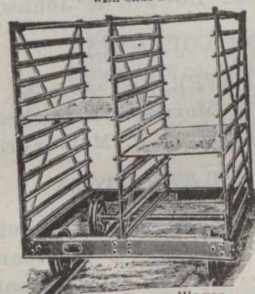

68—Cake Drying Wagon

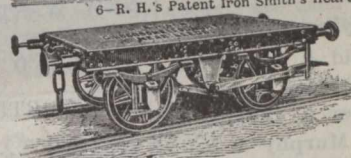

56—10-Ton Platform Railway Wagon

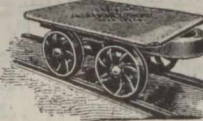

58—Steel Plate Bogie



71—R. H.'s Improved Steel Tank Cart. 200 Gallons capacity



22—Two Tons Steel Plate Bogie. Practically indestructible.

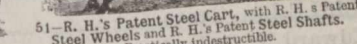

51—R. H.'s Patent Steel Cart, with R. H.'s Patent Steel Wheels and R. H.'s Patent Steel Shafts. Practically indestructible.

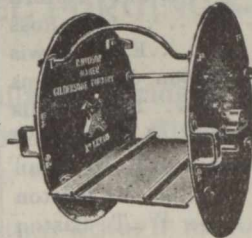

78—Tippler for Mining Wagons



15—R. H.'s Improved Steel Cage, with Safety Grippers and Fallers complete

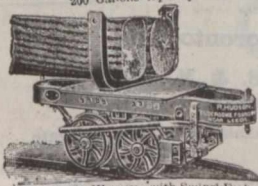

60—Bogie Wagon, with Swivel Fork for carrying Long Balks



70—Foundry Fettling Box



57—Steel Coal Box with Drop Bottom



Self-righting Steel Tip Bucket, fitted with Patent Self-acting Catch if desired



61—Rope Bucket, with R. H.'s Patent Catch for Wire Rope Tramways



42—Mining Kibble with or without Valve in bottom



3—Furnace Coal Wagon

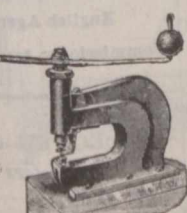

33—Fly Punch

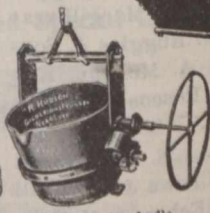

28—Foundry Ladle

The BRITISH CASH REGISTER TILLS.

(Jackson's Patents.)

The Cheapest Cash Register Invented.

Special prices to Canadians under New Tariff.



Agents Wanted in all Canadian Cities.

SOLE MAKERS:

BRITISH MACHINE Co., Ltd.,
West Parade Works, HALIFAX, ENGLAND.

Legal Directory.

Price of Admission to this Directory is \$10 per annum.

NEW YORK STATE.

NEW YORK CITY . . . David T. Davis
(Attorney and Counsellor-at-Law).

ONTARIO.

ARNPRIOR . . . Thompson & Hunt
ARTHUR . . . M. M. MacMartin
AYLMER . . . Miller & Backhouse
BARRIE . . . John Dickinson
BELLEVILLE . . . Geo. Denmark
BLENHEIM . . . R. L. Gosnell
BOWMANVILLE . . . R. Russell Loscombe
BRANTFORD . . . Wilkes & Henderson
BROCKVILLE . . . Wood & Stewart
CAMPBELLFORD . . . A. L. Colville
CANNINGTON . . . A. J. Reid
CARLETON PLACE . . . Colin McIntosh
DESERONTO . . . Henry R. Bedford
DURHAM . . . J. P. Telford
GANANOQUE . . . J. C. Ross
GODERICH . . . E. N. Lewis
HAMILTON . . . Lees, Hobson & Stephens
INGERSOLL . . . Thos. Wells
IROQUOIS . . . A. E. Overell
KEMPTVILLE . . . T. K. Allan
KINGSTON . . . B. M. Britton
LEAMINGTON . . . W. T. Easton
LINDSAY . . . McLaughlin & McDiarmid
LINDSAY . . . Barron & Steers
LISTOWEL . . . S. B. Morphy
MOUNT FOREST . . . W. C. Perry
LONDON . . . W. H. Bartram
L'ORIGINAL . . . J. Maxwell
MITCHELL . . . Dent & Thompson
MORRISBURG . . . Johnston & Bradfield
NEWMARKET . . . Thos. J. Robertson
NIAGARA FALLS . . . Fred. W. Hill
NORWOOD . . . T. M. Grover
OAKVILLE . . . R. S. Applebe
ORANGEVILLE . . . W. J. L. McKay
OSHAWA . . . J. F. Grierson
OWEN SOUND . . . A. D. Creasor
PETERBOROUGH . . . Roger & Bennet
PETROLEA . . . H. J. Dawson
PORT ARTHUR . . . T. A. Gorham
PORT ELGIN . . . J. C. Dalrymple

Legal Directory.

ONTARIO—Continued.

PORT HOPE . . . Chisholm & Chisholm
PORT HOPE . . . H. A. Ward
PRESCOTT . . . F. J. French, K.C.
SARNIA . . . A. Weir
SAULT STE. MARIE . . . Elgin Myers, K.C.
SHELBURNE . . . John W. Douglas
SMITH'S FALLS
Lavell, Farrell & Lavell
ST. CATHARINES . . . E. A. Lancaster, M.P.
ST. MARY'S . . . Armour W. Ford
ST. THOMAS . . . J. S. Robertson
STRATFORD . . . MacPherson & Davidson
TRENTON . . . MacLellan & MacLellan
TEESWATER . . . John J. Stephens
THORNBURY . . . T. H. Dyre
TILSONBURG . . . Dowler & Sinclair
TORONTO . . . Roaf & Roaf
TORONTO . . . Jones Bros. & McKenzie
UXBRIDGE . . . J. A. McGillivray
VANKLEEK HILL,
F. W. Thistlethwaite
WATFORD . . . Fitzgerald & Fitzgerald
WELLAND . . . L. Clarke Raymond
WINGHAM . . . Myer & Dickinson
WINDSOR . . . Patterson, Murphy & Sale
WALKERTON . . . A. Collins
WALKERTON . . . Otto F. Klein

QUEBEC.

BUCKINGHAM . . . F. A. Baudry
MONTMAGNY . . . Albert J. Bender
PERCE & NEW CARLISLE . . . Jos. Garon
RICHMOND . . . Edward J. Bedard
STANSTEAD . . . Hon. M. F. Hackett
SWEETSBURG . . . F. X. A. Giroux
WATERLOO . . . C. A. Nutting

NOVA SCOTIA.

AMHERST . . . Townshend & Rogers
ANNAPOLIS ROYAL . . . H. D. Ruggles
ANTIGONISH . . . A. Macgillivray
BRIDGETOWN . . . T. D. Ruggles & Sons
BRIDGEWATER . . . Jas. A. McLean, K.C.
KENTVILLE . . . Roscoe & Dunlop
LUNENBURG . . . S. A. Chesley
PORT HOOD . . . S. Macdonnell
SYDNEY . . . Crowe & Burchell
SYDNEY, C. B. . . MacEchen & McCabe
YARMOUTH . . . E. H. Armstrong
YARMOUTH . . . Sandford H. Pelton

Legal Directory.

NEW BRUNSWICK.

CAMPBELLTON . . . H. F. McLatchy
EDMUNSTON . . . A. Rainsford Balloch
HAMPTON . . . A. Le B. Tweedie
MONCTON . . . Harvey Atkinson
SUSSEX . . . White & Allison

PRINCE EDWARD ISLAND.

CHARLOTTETOWN,
McLeod & Bentley
CHARLOTTETOWN,
McLeod, Morson & McQuarrie

MANITOBA.

PILOT MOUND . . . W. A. Donald
SELKIRK . . . James Heap
WAWANESA . . . Jos. H. Chambers
WINNIPEG . . . Howard & Johnson

BRITISH COLUMBIA.

NEW WESTMINSTER,
Morrison & Dockrill
ROSSLAND . . . P. McL. Forin

NORTHWEST TERRITORY.

CALGARY . . . Lougheed & Bennett
CALGARY . . . McCarthy & Stuart
EDMONTON . . . Bown & Robertson
RED DEER, Alberta . . . Geo. W. Greene

Legal.

Toronto, Ont.

JONES BROS. & MACKENZIE,
Barristers & Solicitors,
Canada Permanent Chambers, Toronto.
CLARKSON JONES, BEVERLY JONES,
GEO. A. MACKENZIE, C. J. LEONARD.
English Agent: JONAS AP JONES,
99 Cannon St., London,
Commissioner for N. Y., Illinois and other States

MAC ECHEN & MACCABE,
Barristers and Attorneys-at-Law,
Notaries Public, etc.,
MacDonald's Block, Sydney,
Cape Breton, Nova Scotia.
Real Estate and Commercial Law
receive Special Attention.

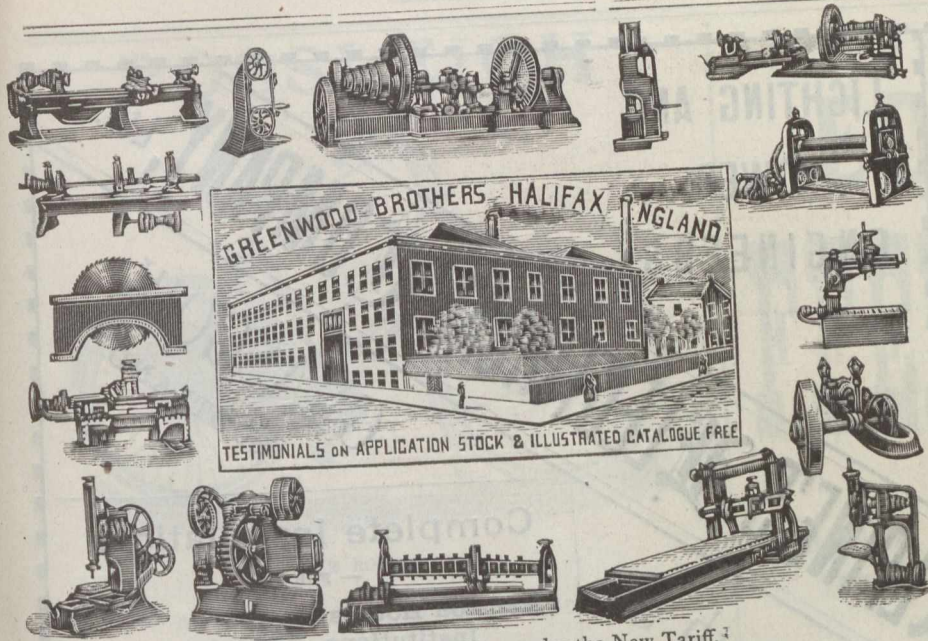

GREENWOOD BROTHERS HALIFAX ENGLAND
 TESTIMONIALS ON APPLICATION STOCK & ILLUSTRATED CATALOGUE FREE

Special prices to Canadians under the New Tariff.

W. & F. P. CURRIE & CO.,
 134 McGill Street,
 Corner St. Paul St.
MONTREAL.

Sofa, Chair and Bed Springs,

A Large Stock always on Hand.

Roman Cement, Portland Cement,
 Water Lime.

Drain Pipes, Vent Linings,
 Fire Covers, Fire Bricks, Fire Clay
 Whiting, Plaster of Paris,
 Borax, China Clay, etc.

The **Largest Buildings Built**

CAN BE EFFICIENTLY WARMED BY

Our "BRIGHT IDEA"
 Safety Water Tube Boilers for Hot Water
 or Steam.

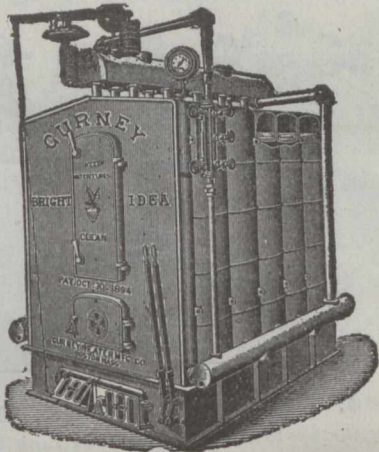

They provide immense heating capacity from amazingly little fuel; and will burn any kind of fuel. Neither steel nor wrought iron nor any gaskets are used in their construction. Their durability is positively unequalled. Made in Eight Sizes with Guaranteed Capacity.

FOR SMALLER BUILDINGS OUR FAMOUS
 "OXFORD 400 SERIES"
 and "DORIC" BOILERS

GIVE THE ACME OF COMPLETE SATISFACTION.

Let us give you full Information and Details.

The **GURNEY-MASSEY CO., Limited, MONTREAL.**

PILE SHOES

With Chilled Points

(Copley & Co's Patent),

For

PILE WORK of Every Description.

PRICES AND TESTIMONIALS
 ON APPLICATION.



Copley, Turner & Co., Ltd.
 MIDDLESBOROUGH, ENGLAND.

John Rogerson & Co., Ltd.

WOLSINGHAM, Co. DURHAM,
 ENGLAND.

**STEEL CASTINGS FOR
 STEEL FORGINGS**

Ships, Docks, Railways, Bridges, Dredgers, Loco.
 and Marine Engines, Gold Mines, Collieries, Elec-
 trical Plant, &c.

FINISHED WORK IF REQUIRED.

CHEMICAL PLANT

IN HIGHEST QUALITY. GUARANTEED NON-CORROSIVE METALS.

STEAM FITTINGS, CASTINGS, INGOTS,
 And Special Goods in various Metals and Alloys.

CHEMICAL PLUMBING.

Also Patent Plugs and Seats for Railway Tanks,
 Heaters, Syphons, Lead-Burning Apparatus, Bottling Cocks, Gauge
 Taps, Saturator Valves, Junction Pieces, Etc., Etc.

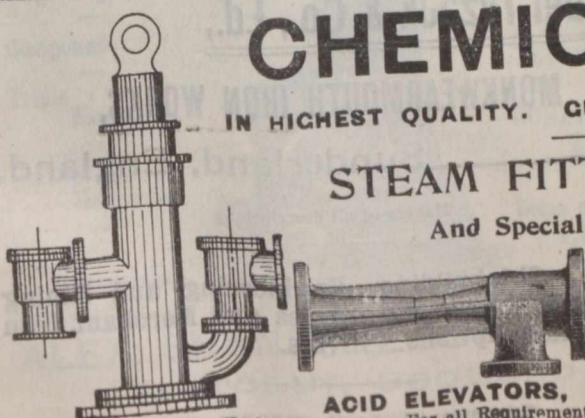

ACID PUMPS, Various kinds.
 ACID ELEVATORS,
 For all Requirements.

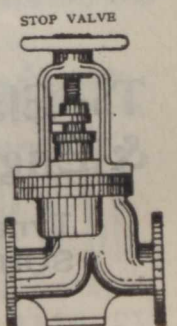

CHAS H. C. RUDD & PARTNERS, Thistle Works, St. Anthony's, NEWCASTLE-ON-TYNE, Eng.

Telegraph
 "Rudd, St. Anthony's,
 Newcastle-on-Tyne."

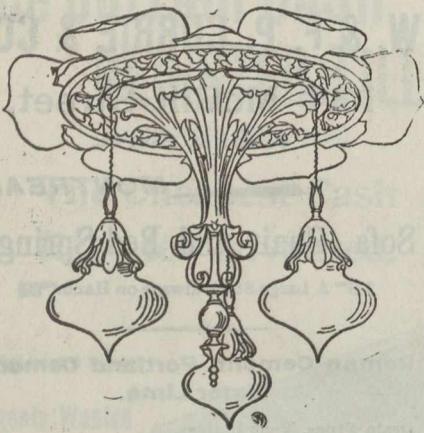

LIGHTING AND
POWER
ENGINEERS.

M'ALPINE'S ELECTRICAL COMPANY, Ltd.,
GLASGOW,
SCOTLAND.

Complete Installations

— FOR —

Mansion Houses,
Institutions, Factories,
Mines, Ironworks,
Railway Stations,
Docks, Shipyards,
Ships, Etc., Etc.

60 Bath St.,

WILLIAM SPENCE,

Cork Street Foundry and Engineering Works,
107 CORK STREET,
Dublin, Ireland.

Manufacturer of

Shunting LOCOMOTIVE ENGINES

For Narrow-gauge Railways and Tramways.

Cut will be inserted as soon as received.

M'HAFFIE & CO.,

Glasgow Sheet-Metal Works,

107 JOHN ST., - GLASGOW, SCOTLAND.

SPECIALTIES.

Street Lamps—In Tinplate, Zinc, and Copper.

Packing Cases—For Calenderers, Wholesale Warehousemen and Shippers.

Japanned Trunks—In Steel, Iron, and Tinned Plate.

Stencil Plates—In Zinc, Copper, and Brass.

Metallic Kegs, Oil Drums, Tanks, and Cisterns.

Telegraphic Address: "PACKING" SOUTH SHIELDS.

Contractors to the Admiralty.

The Elastic Metallic Packing & Engineering Co., Ltd.

Tyne Dock Entrance,
SOUTH SHIELDS, ENGLAND.

...Engineers, Brassfounders, Coppersmiths, &c...

Special prices to Canadians under the New Tariff.

JOHN STIRK & SONS

ENGINEERS'
TOOL MAKERS.

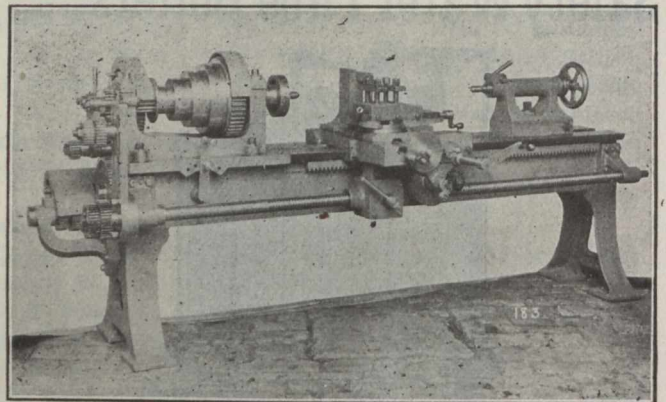

Ovenden Road, - DUNELM, ENGLAND.

Special prices to Canadians under New Tariff.

WINDOW BLINDS.

PRICE LIST F.O.B. Glasgow.

Holland Blinds and Slip Spring Rollers, . . .	4½d per sq. ft.
Spanish Sun Blinds,	2/- "
Louvre Shutter Blinds,	4/- "
Shop Awnings with Spring Rollers, jointed iron arms and wood boxes,	12/6 per foot run.

JOHN BRYDEN & SONS, 60 Benfield Street,
GLASGOW, SCOTLAND.

Samuel Tyzack & Co., Ltd.,

MONKWEARMOUTH IRON WORKS,

Sunderland, England.

Makers of all descriptions
....of....

Iron for Shipbuilding, Engineering and Mining
Purposes. Bedstead Angles and Merchant Iron
of all descriptions. Rivets.

Telegrams: "TYZACK, SUNDERLAND."

ROSSLEIGH

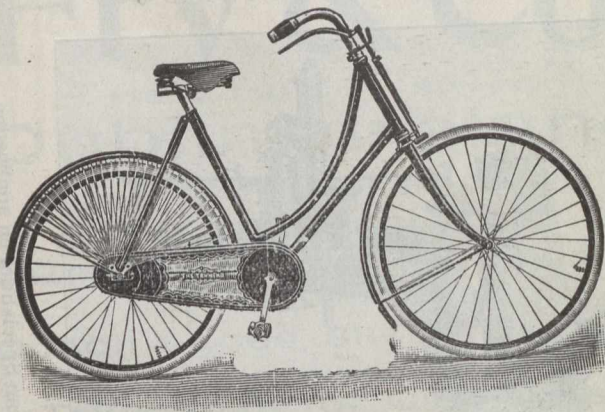

THE ROSSLEIGH.

As Supplied to H. M. Government.

Cycles and Motors.

Special terms to Canadians under the New Tariff.

Catalogues Free

The New Rossleigh Cycle and Motor Co., Ltd.,
1 York Buildings, Edinburgh, Scotland.

HILEY & ORCHAR,

Mechanical & Electrical Engineers,

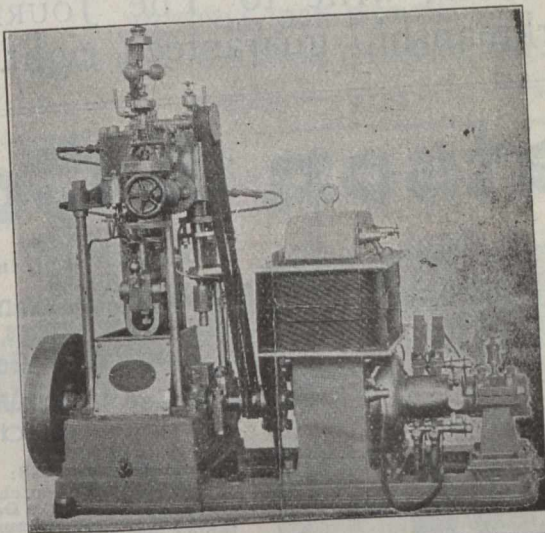

Manufacturers of DYNAMOS, Etc.

21 North Tay St., DUNDEE,
SCOTLAND.

SHANKS'S STEAM ENGINES.

For Electric Lighting, Traction, &c.

MOST MODERN DESIGNS.

- Single Cylinder,
- Compound,
- Triple Expansion,
- Vertical and Horizontal,
- Perfect Governing,

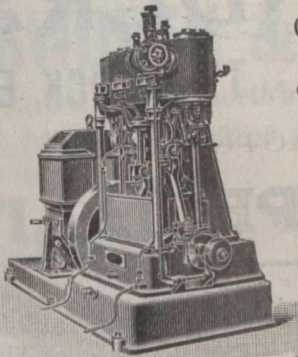

- COMPOUND ENGINES of High Speed—Enclosed Type.
- GOORLISS ENGINES.

Sizes up to 1,000 brake H. P.

ALEX. SHANKS & SON, Limited,
Arbroath, Scotland,

—AND—
BUSH LANE HOUSE CANNON ST., LONDON, Eng

AGENCIES AT ALL PORTS.

EDMISTON FEED FILTERS

DESIGN "T."

- DOUBLE FILTRATION.
- INDEPENDENT VALVES.
- VERTICAL FILTRATION.
- LARGE AREA.

The Filters are designed to work vertically; the grease collects at the top of the chambers, leaving the under part comparatively free, thereby greatly reducing the working pressure.

GLASGOW PATENTS CO.,

(WILLIAM J. H. ADAM, Secretary.)

94 Hope St., GLASGOW, Scotland.

(Cut will be inserted as soon as received.)

VALVES! VALVES!! ALL KINDS.

TURNBULL'S

... PATENT

Safety Valves.

Awarded Gold, Silver and Bronze Medals.

ALEX. TURNBULL & CO., Ltd.,
Bishop Briggs,

Special Prices
Under New Tariff.

GLASGOW,
SCOTLAND.

Telegraphic Address:—"FISHER, ENGINEERS, PAISLEY."

STEAM & HAND STEERING-GEARS, Windlasses

—AND—

Capstans.

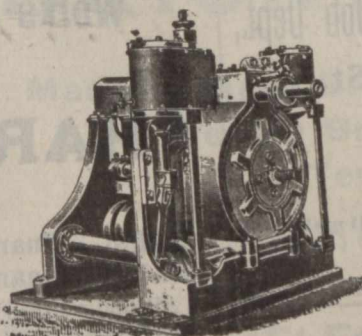

FISHER & CO.,

Engineers,
St. Mirren's Engine Works, - PAISLEY,
SCOTLAND.



RECOGNIZING the value of the Journal of Commerce as an advertising medium—and as a trade winner—we insert this ad. In other words, we want your trade—

YOUR PRINTING.

Watch Your Mail Bag

If it contains MAIL ORDER PRINTING from us—then you'll be satisfied



If it is STATIONERY you want we suggest

“Keystone”

—You can't get anything better for the money.

Write.

By return mail we'll give you an estimate.

Journal of Commerce Job Dept,
171 St. James St.
MONTREAL.

N.B.—Mention this ad. and we'll make our offer still better.



Improved 5ft Radial Drilling and Tapping Machine.

2½" SPRINDLE, 18" SELF-ACTING FEED.

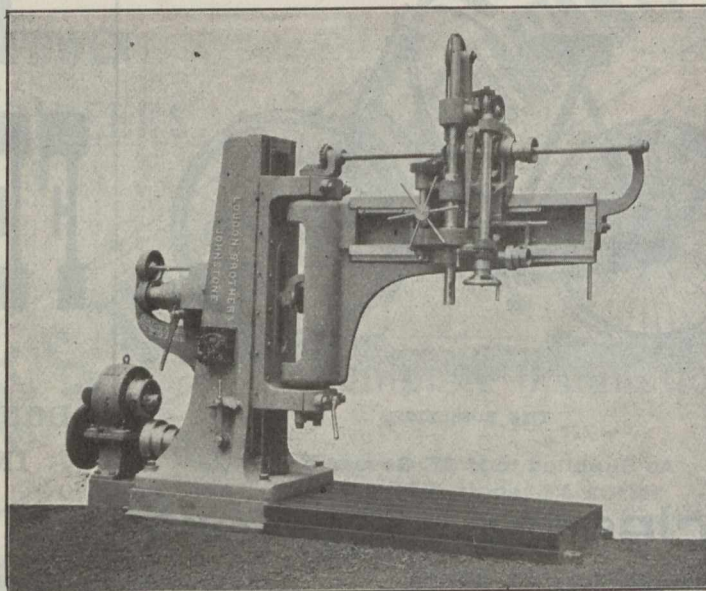

GLASGOW OFFICE:
39 West Campbell Street.

Catalogues of our Specialities on application.

Radial Drilling Machine.

LOUDON BROS., Clyde Engineering Works,
JOHNSTONE, SCOTLAND.

WHEN you want anything in the line of **PRINTING**, write to The JOURNAL. Prices and workmanship guaranteed right.

D. Watson & Co.

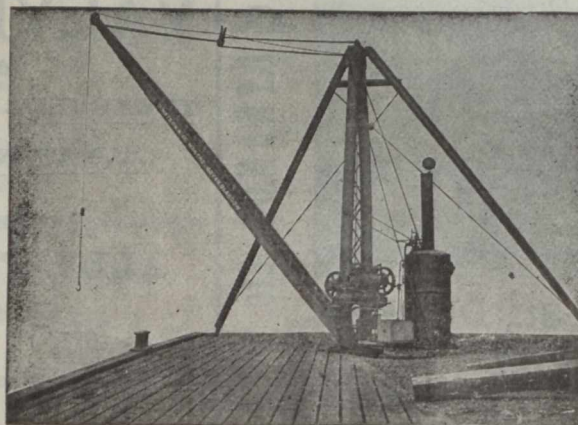

Engineers, Crane & Chain
Makers,
GOVAN CRANE, CHAIN and TESTING WORKS,
Harmony Row, Govan,
GLASGOW,
Scotland.

SPECIALTIES:
Hand and Steam Scotch Derrick Cranes, Ship's Deck Cranes, Hand and Steam Portable Cranes, Wharf Cranes, Mortar Mills, Piling Engines, Hoisting Engines, and all kinds of Contractors' Plant.
Extra Best Short Link Crane and Stud Cable Chains, Pitch Chains, Messenger Chains, and Anchors of every description.

J. T. HENDERSON,

Works and Offices - TYNE DOCK, England,

MANUFACTURER OF:

“HAROC” SPECIALITIES.

- “HAROC” Enamels for Holds, Bunkers, Tanks, Tank Tops, etc.
- “HAROC” Enamels for the Covering of Roofings of Sheds, etc. (either Wood or Iron).
- “HAROC” Metallic Elastic Cement for Boiler Bottoms (inside), and Silicate Cotton Mattresses for Boiler Bottoms (outside).
- “HAROC” Non-Conducting Composition for Covering Boilers, Pipes, etc., etc.

Fry & Co.

115 & 116 Cork Street,
Dublin, Ireland

ALWAYS HOLD A HUGE STOCK OF

Carriage Cloths,
Carpets, Canvasses, &c.

ARE ACTUAL MANUFACTURERS OF

Coach Laces, Silks, Tabarets

AND EVERY VARIETY OF

Trimmings for Carriages.

Renowned for
Considerably over a Century

FOR THE BEAUTY OF THEIR DESIGNS &
THE FAST QUALITY OF THEIR DYES & ARE

Still at the Top.

Established 1860.

BINNS BROS.,

ENGINEERS' TOOL MAKERS,

VICTORIA IRON WORKS,
Water Lane, HALIFAX, Yorkshire, Eng.

Special terms to Canadians under new Tariff.

Telegraphic Address:
"BROADBENT, SOWERBY BRIDGE."

Contractor to
H. M. Government.

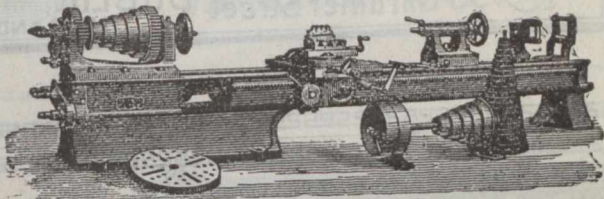

HENRY BROADBENT,

ENGINEER'S
TOOL MAKER,

Hollins
Tool Works.

Sowerby Bridge,
Yorkshire, Eng.

Special prices to Canadians under the New Tariff.

ESTABLISHED 1820.

HY. WADSWORTH & SON,

Sole Manufacturers of Wadsworth's Patent
STREET WATERING, SANDING, SWEEPING & CLEANSING
MACHINES, &c.

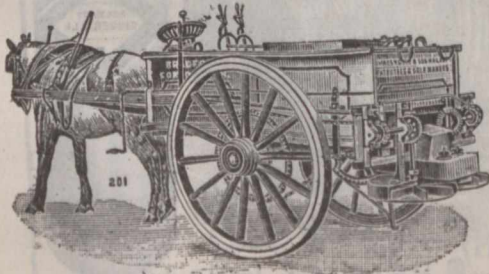

GOLD
MEDAL
Awarded,
PARIS
EXHIBITION,
1900.

SANITARY IMPLEMENT WORKS, HALIFAX, ENG.

Sissons & White,

HULL, ENGLAND.

PATENT STEAM

PILE DRIVER.

TESTIMONIAL.



65 King Street, Manchester.

We have tried this machine, besides those of
other makers, and taken altogether, we have no
hesitation in saying that it is the most satisfac-
tory Pile Driver for Contractors' Purposes.

Exors. of T. A. WALKER,
(pro. L. P. Nott),

Messrs. Sissons & White,
Hull.

Description and Testimonials sent on Application.

...PATENT SPRING BEAM POWER HAMMER...

The most Perfect on the Market. The BLOW
can be REGULATED whilst RUNNING.

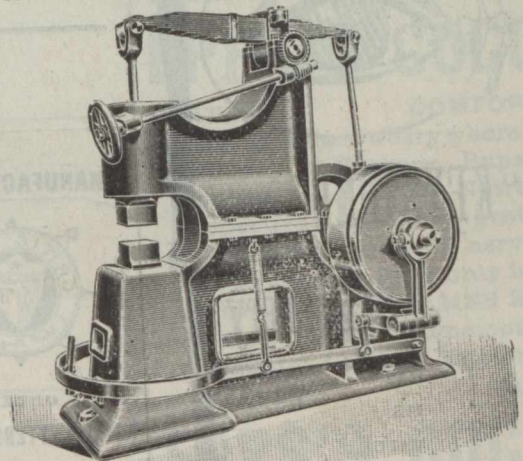

...SOLE MAKERS...

CARTER & WRIGHT,

Hexagon Iron Works, HALIFAX, ENGLAND.

Patent Cold Iron Sawing Machines
and Machinery Tools of every description.



THE

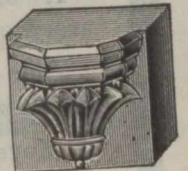

MODEL

BRICK & Terra-Cotta Works, Lim'd

Machine Made Bricks,
Pressed Bricks and
Terra-Cotta Work.

Balmoral,

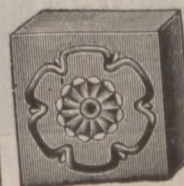

BELFAST,

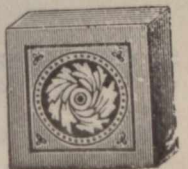

Ireland.

GROCERY MEN.

BROKERS—Wanted an energetic and reliable man to push our Irish Preserves during the coming season. Apply, stating terms and the district proposed to work, to

WM. VINT & SONS,
Unity Street Preserve Factory,
BELFAST, IRELAND.

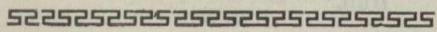
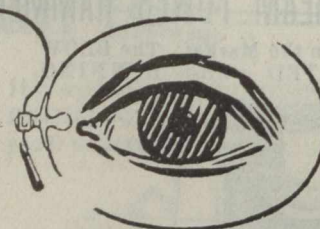
"KEYSTONE"
Stationery

HAS
ITS
VALUE.

It's worth so much
—no more.

You pay so much—
and no more.

It's all one price to
everybody.

Your competitor
pays what you pay.

"Keystone" is put
up in neat boxes, thus
enabling you to keep
a clean, presentable,
standard line.

Send for figures.

Journal of Commerce Job Dept.
171 ST. JAMES ST.

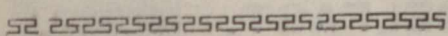

JOHNSTON BAIRD & CO.,

GLASGOW, SCOTLAND.

Coffee Essence

— AND —

Sauce Manufacturers, &c.



**BAIRD'S ESSENCE OF
COFFEE & CHICORY.**

**BAIRD'S
WORCESTERSHIRE + SAUCE.
WHOLESALE AGENTS WANTED.**



**FRESH FRUIT
LEMONADE**

Made under **TAYLORS**
New **PATENT** Non-Alcoholic
TAYLOR & Co. Process
35 Gardiner Street **DUBLIN**
IRELAND

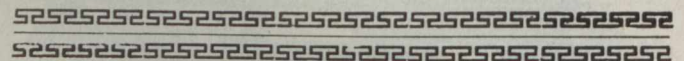

MANUFACTURERS



**UNDER
ROYAL LETTERS PATENT.**

Specialities.

- "Critic" Soda
- "Critic" Lemon Soda
- Old Stone Beer



"CRITIC" LEMON SODA

Made under **TAYLORS**
New **PATENT**
Non-Alcoholic **PROCESS.**
TAYLOR & Co.
DUBLIN IRELAND

SODA WATER. GINGER ALE

**CHAMPAGNE
CIDER.**

**AERATED
QUININE**

**AERATED
SARSAPARILLA
ETC.**



**Cochran & Company
BELFAST Ireland**



FALKIRK, SCOTLAND.

NON-ALCOHOLIC FREE FROM SPIRIT

HANNAH'S CHOICE

FRUIT WINES

ORANGE

LIME JUICE
CORDIAL
GINGER
LEMON

RASPBERRY
PEPPERMINT
GREEN GINGER
PORT SHERRY
GINGER BRANDY
STRAWBERRY
BLACK CURRANT
LEMON SQUASH

HANNAH'S
FRUIT WINES
GINGER

EDINBURGH & NEWCASTLE ON TYNE

EXCELSIOR WORKS GLASGOW

SAMUEL HANNAH & CO., GLASGOW, SCOTLAND.

WANTED

Agent to represent a firm of manufacturers of Ornamental and General Wire Work. Address: "Foggin"
Care of JOURNAL OF COMMERCE,
Montreal, P.Q.

WINDSOR,

Essex Co., Ont., Canada.

The Board of Trade is prepared to entertain proposals for the location of Industries in the city. Population of city and suburbs about 16,000. No better rail and water transportation facilities in Canada. Address with particulars:
F. H. MACPHERSON,
Secretary B. of T

Do you require any Printing this week?
Telephone Main 238 will ensure prompt service.

Journal of Commerce,
171 St. James Street.

EPPS'S COCOA

GRATEFUL COMFORTING
Distinguished everywhere for Delicacy of Flavour, Superior Quality, and highly Nutritive Properties. Specially grateful and comforting to the nervous and dyspeptic. Sold only in ¼-lb. tins, labelled JAMES EPPS & Co., Ltd., Homœopathic Chemists, London, England.

BREAKFAST SUPPER

EPPS'S COCOA

GAS ENGINE FOR SALE.

Otto Make.

Bought of and guaranteed by

Schleicher, Schumm & Co.,

of Philadelphia.

Ten horse-power. Slide Governor. Needs no engineer. Can be started immediately with a match. No smoke. No smell. In first-class running condition. Economical. Costs from 90 cts. to \$1.25 per day for gas and all expenses. Always ready.

Apply to

M. S. Foley,

171 St. James Street.

Sanderson's EXTRACT OF COFFEE,

— UNSURPASSED IN —

* Purity, Strength, and Flavor. *

SAMPLES AND PRICES ON APPLICATION TO

A. C. SANDERSON & CO., Easter Road
EDINBURGH, - SCOTLAND.

SHANKS'S GINGER ALE

AROMATIC

Is a drink attractive in appearance, fragrant to smell, and grateful to the palate.

Is perfectly wholesome, and made from choicest ingredients only.

Is entirely free from alcohol, while stimulating in a high degree.

Is agreeably piquant and full flavored.

Is invaluable for Yachting, picnic parties and for the Ballroom.

Is guaranteed to keep.





ONLY
MEDAL
1883

J. SHANKS & Co.
LIMITED
DUBLIN - IRELAND

E. LUMB & CO.,
Green Mount Works, HALIFAX, Eng.

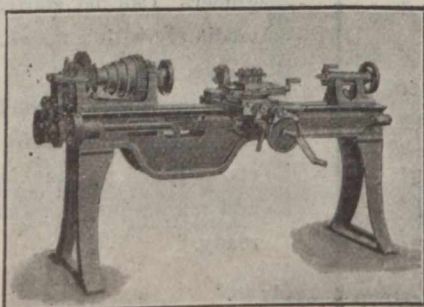

Machine Tools of every Description for Engineers
Wood-Workers, &c., &c.

IRISH GINGER ALE.

HOVENDEN & ORR, Ltd.,

Agents wanted in Canada. Dublin, Ireland.

Telegraphic Address:
"PHENIX," KEIGHLEY.

**W. Summerscales & Sons,
LIMITED.**

Coney Lane Works,
KEIGHLEY, England.

Manufacturers of
every class of

LAUNDRY & DOMESTIC MACHINERY,
For Canadians, under the New Tariff.

Farrar's Improved Malleable Iron
— Steam, Water & Gas Fittings. —

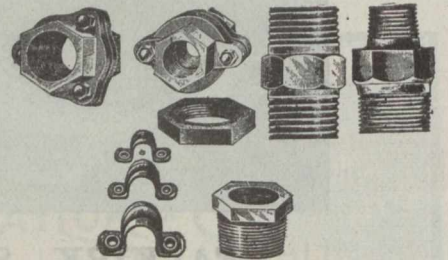

These goods are all
screwed to Standard
sizes and perfectly li-
neable.

Also Makers of
Every Description of **GUN-METAL FITTINGS.**

Brass and Malleable Iron Castings to Order.

THOMAS FARRAR, Borough
Brass Works,
KEIGHLEY, England.

D. Battye & Son,

TALLOW MELTERS AND REFINERS,

Manufacturers
of . . .

CYLINDER & LUBRICATING OILS

Wheel Greases, Boiler Composition, &c.

Cylinder Oil, Engine Oil, Stainless Lubricating Oil, Gas Engine
Oil, Special Dynamo Oil, Castor Oil, Wheel Grease, Water Wheel
Grease, Belting Grease, Corve Grease.

Office: Cloth Hall St., HUDDERSFIELD, Eng.

Works:—CROSLAND MOOR BOTTOM.
Samples & Prices on application.

Special Prices to Canadians under the New Tariff.

Cotton Rope, Clothes Lines,
Sash Cords, Skipping Ropes.

By
New
Automatic
Machinery.

WRITE FOR SAMPLES AND PRICES.

A. E. HAWORTH,
ROPE MAKER,

Bell Street, - - BOLTON, ENGLAND.



FIRE BRICKS
And
BOILER
BRICKS.

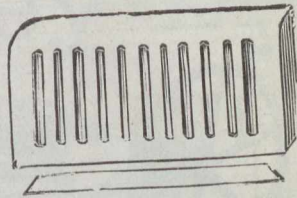

John R. Fyfe & Co

Shipley
Firebrick Works,
Shipley, Yorkshire, Eng.



Special prices to Canadians under the New Canadian Tariff.

M. Coulson & Co., Ltd.

ENGINEERS,

Spennymoor, Co. Durham,
England

Manufacturers
of....

Coal Washing...
and Screening Plants.

Heapsteads, and Colliery Plant of all Descriptions.

MAKERS OF

Wood & Burnett's "Murton" Coal Washer, "Positive" and "Simplex" Tipplers, Automatic Delivery Screens, "Blackett" Washer (Blackett & Palmer's Patent), Etc.

Special prices to Canadians under new Tariff.
Full particulars on Application.

HARRAP Bros.

Sole Makers of the Celebrated

CABLE



(REGISTERED)

RUG
WOOL

Which may be had from
MESSRS S. & J. WATTS & CO., MANCHESTER,
OR ANY WHOLESALE HOUSE.

Also Manufacturers of WORSTEDS, SCOTCH FINGERINGS,
GERMAN WOOLS, "PRIMULA" ANDALUSIAN, and all
kinds of KNITTING WOOLS.

BEGTIVE MILLS, ALVERTHORPE, WAKEFIELD, Eng.
Special terms to Canadians under the new tariff.

Telegraphic and Cable Address
"SMITHS CLECKHEATON."
A B C Code (4th edition)

Pyenot Works.
Phenix Works

E. & A. Smith & Co.,

LIMITED,

WIRE MANUFACTURERS,

Manufacturers of
all kinds of

Cleckheaton, Eng.

Patent and Plough Steel Wires for Mines
and Hauling Purposes, Wire for Steel Haw-
sers. Music Wire a Speciality.

Established 1858.

George Sampson & Son,

LIVERSEGE LEATHER WORKS,

Liversedge, Yorkshire, England.

BEST BARK TANNED

ENGLISH BELTING

Single, Double and Treble MAIN DRIVING BELTS,
ANY WIDTH.

LEATHER BOOT LACES.

Waxed and Russet Kip Butts, Improved Condenser Rubber
Leathers, Bark Tanned Picking Straps, &c., General Mill Fur-
nishers, &c.

Special prices to Canadians under the New Tariff.

At the Office of

The "JOURNAL of COMMERCE"

- YOU CAN GET -

Everything in
the line of...

Job Printing.

THORPE, JOHNSON & CO.,
... Limited

Keighley, England.

MANUFACTURERS
OF THE

Finest Bobbins in England

FOR THE
TRADE.

Special terms to Canadians under the new Preferential Tariff.

Cut will be inserted when received

W. E. W. Clay,

LOW
HALL
MILLS,

HOLBECK, LEEDS, Eng.



Manufacturer of BABY CARRIAGES, PERAMBULATORS
and MAIL CARTS of the latest designs, under the new
Canadian Tariff.

Give the
JOURNAL OF COMMERCE
— A TRIAL FOR —
JOB PRINTING.

LOCAL.

GIBBONS, MULKERN & HARPER,
Barristers, Attorneys, &c.
Office: Corner Richmond and Carling Sts.
GEO. C. GIBBONS, K.C., P. MULKERN,
FRED. F. HARPER

BROSSEAU, LAJOIE & LACOSTE,
Advocates.
Banque Jacques Cartier B'dg., 7 Place d'Armes,
T. BROSSEAU, LL.B. Montreal.
H. GERIN-LAJOIE, LL.L., PAUL LACOSTE, LL.L.

Kingston, Ont.

SMYTHE & LYON,
Barristers, Solicitors, &c.,
E. H. SMYTHE, LL.D., K.C. H. I. LYON.

Seaforth, Ont.

McCAUGHEY & HOLMSTED,
Barristers, &c.

London, Ont.

W. H. BARTRAM,
Barrister, Solicitor, Notary, &c.
OFFICE: 99 DUNDAS STREET WEST.

White Capsule Ale
.... India Pale.

IS BREWED BY

The Canadian Breweries Ltd.

MONTREAL, Que.

SUCCESSOR TO

The CANADIAN BREWING CO.
and H. A. EKBERS.

Unsurpassed for Family Use

BELL TELS. EAST 465 AND 140

THE **JOURNAL OF**
COMMERCE
FINANCE AND INSURANCE REVIEW.

DEVOTED TO

Commerce, Finance, Insurance, Railways,
Manufacturing, Mining and Joint
Stock Enterprises.

ISSUED EVERY FRIDAY MORNING

SUBSCRIPTION.

Montreal Subscribers,	\$3 a year
Mail Subscribers to any other part of	
Canada,	\$2 a year
British Subscribers,	21 Stg.
American,	\$3 a year
Single Copies,	10c, each

Editorial and Business Offices:

Nos 171 and 173 St. James Street,
Head of St. John Street,
MONTREAL.

M. S. FOLEY, Editor, Publisher and Proprietor.

We do not undertake to return unused manuscripts.

The Editor cannot under any circumstances undertake to return unused manuscripts, or enter into any correspondence concerning it.

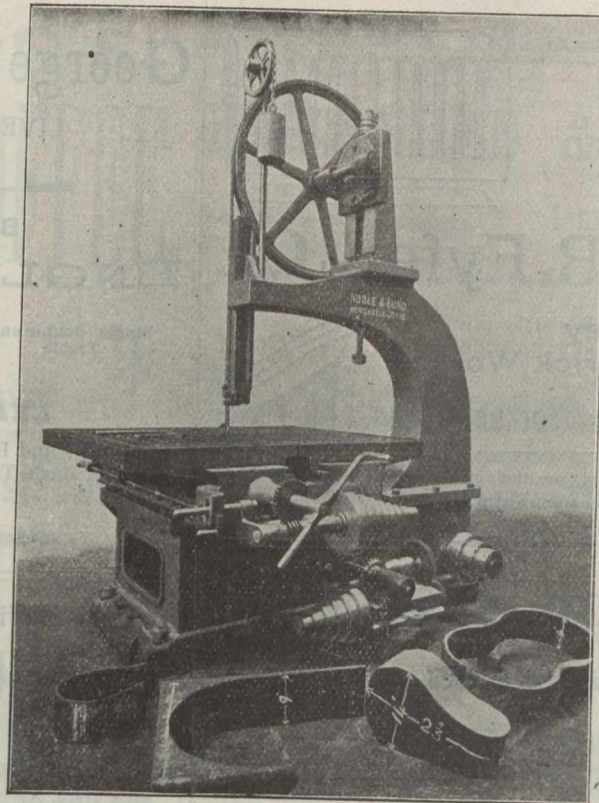

NOBLE
AND
LUND,

Ltd.,

Felling-on-Tyne,
ENGLAND.

MAKERS OF

High-Class . .
Machine . . .
Tools for . . .
Engineers and
Shipbuilders. .

—SPECIALTY—

**BAND SAWING
MACHINES**

FOR CUTTING IRON AND STEEL, COLD!

We make these Machines so that bars of any length can be cut square with the bar.

OVER 500 MACHINES SOLD.

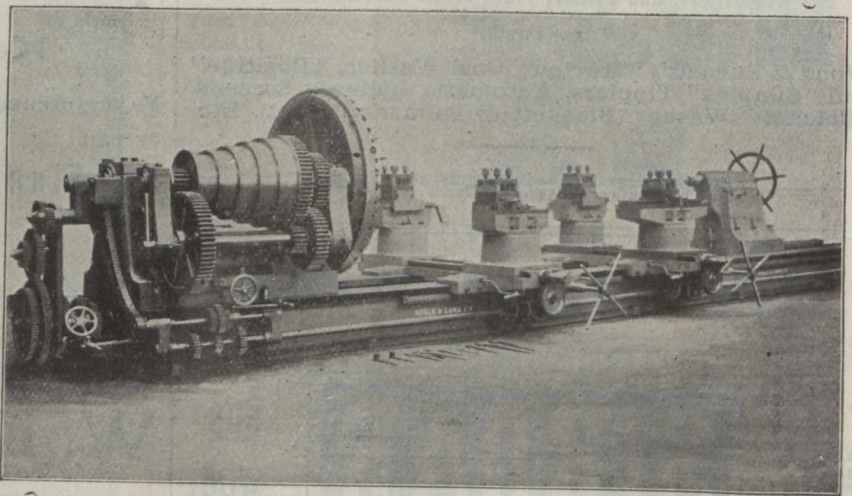

40-in. Centre Crank Shaft Turning Lathe.

Telegram: "HALEY," Cleckheaton.
A.B.C. Code used.

S. Haley & Son,

LIMITED.

CLECKHEATON, YORKSHIRE, ENG.

Manufacturers of every
Description of

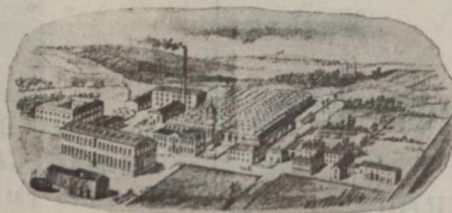

**Card Clothing for
Woollen, Worsted
& Cotton**

CARD CLOTHING with Patent Bright Hardened and Tempered Steel Wire, Mild Steel or Iron Wire, specially polished Plough Ground, Needle Pointed, Angle, Single and Double Convex, Combined Round and Flat, and all other shaped Wires, in any Foundation used in the Trade.

Also Card Clothing with best Patent Bright Hardened and Tempered Steel Wire with ELECTRIC HARDENED POINTS. Experienced men sent out to Nail Cards when required.

Swinney Bros, Ltd.,

Telegrams: "SWINNEY MORPETH."

ALL BEARINGS GUN METAL.

The IDEAL
DOUBLE SHAFTED
**BRICK
MAKING MACHINE**
For Strong Clay.
No Lamination.

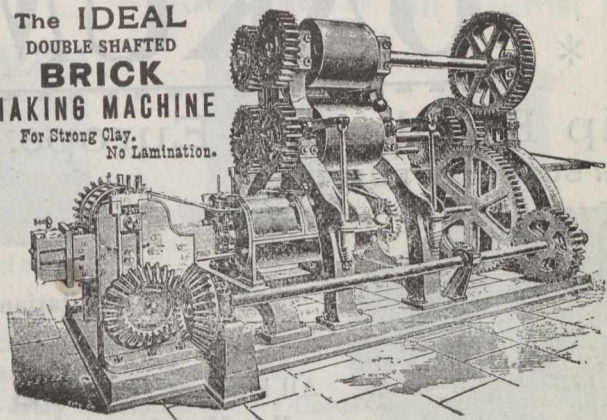

Send for Catalogue & Testimonials.

ENGINEERS,
Wansbeck Ironworks, MORPETH, ENGLAND,
Manufacturers of . . .
Brickmaking Machines,

(Single and Double Shaft Pug Mill)
adapted to every kind of Plastic Clay.

—SPECIALITIES—

Hard Rollers, Machine Made Wheels,
Improved Trust Bearance, Metallic Die.

Our Motto is—"STRENGTH, SIMPLICITY AND EFFICIENCY."

GEORGE ANGUS & Co., William Lawson & Sons,

LTD.,

Newcastle-on-Tyne, England.

Manufacturers of

**LEATHER,
INDIA RUBBER, Etc.,**

FOR GENERAL MECHANICAL PURPOSES.

Specialities in

Leather, Cotton and Hair Beltings,

**INDIA RUBBER SHEETS,
VALVES, WASHERS,
BUFFERS, ETC.**

CONTRACTORS TO THE ADMIRALTY, HOME, AND
FOREIGN GOVERNMENTS.

ST. JOHN'S WORKS,

Newcastle-on-Tyne, England.

BRANCHES AT LONDON, LIVERPOOL,
LEEDS, CARDIFF, MANCHESTER.

—WRITE FOR PRICE LISTS AND TERMS.

Telegrams: "Robson, Shipley." National Telephone: "67 Shipley."

"THE NONPAREIL"

SHIPLEY GAS ENGINE.

Gold Medal Bradford Trades
Exhibition, 1898.

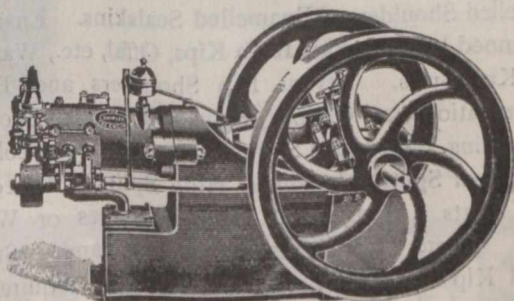

Diploma, Newcastle Electrical
Exhibition, 1897.

Sole Maker **JOHN ROBSON,**
SHIPLEY, Yorkshire, England.

ESTABLISHED 1866.

Manufacturers of every description of
Hemp & Jute Ropes, Lines & Twines.

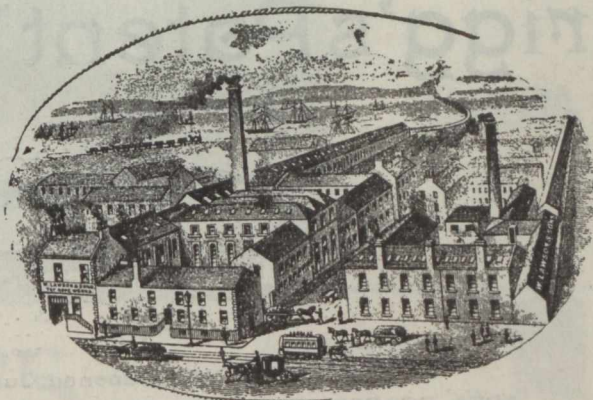

TAY ROPE WORKS.

DUNDEE, SCOTLAND.

—SPECIALTIES

Box Cords, Clothes Lines, Tent Lines, Polished Twines

Gaskins, Driving Ropes, Tarpaulins

and Waterproof Coverings.

The JOHN L. CASSIDY CO., Ltd.,

....IMPORTERS OF....

China, Crockery and Glassware,
FROM ALL COUNTRIES.

339, 341-343 St. Paul Street,

MONTREAL, Que.,

BRANCHES—Ottawa, Ont.; Winnipeg, Man.; Victoria, B.C.

WM. CLEGHORN,
DUNDEE, SCOTLAND. * *

OAKUM

Used by the Largest Ship Builders in Europe.

ALSO—ANTISEPTIC TOW FOR SURGICAL PURPOSES.

JUTE YARN

from 7 lbs. up to heavy rove,
 in single and twist and in
 bundle, warps, or balls for
 Rope-making, etc., etc.

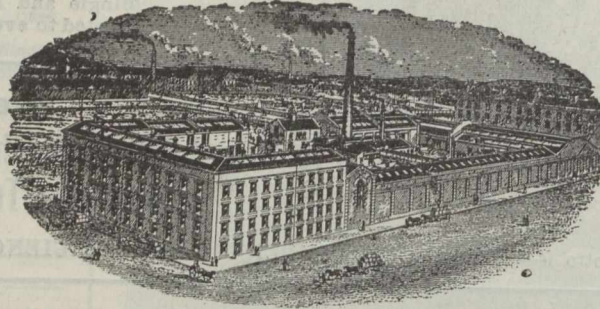

WOOL (Imitation)
 for mixing with Wool.

All kinds of **TOWS** for
 Felt Manufacture.

LINEN and COLORED JUTE Thread Waste for Engine Cleaning, etc.

Samples and Prices on Application to

Works:
 ARKLAY ST.

WM. CLEGHORN, DUNDEE, SCOTLAND.

TELEGRAMS:—"CEMENT, DUNDEE."

Brigg's Patent Viaduct Solution

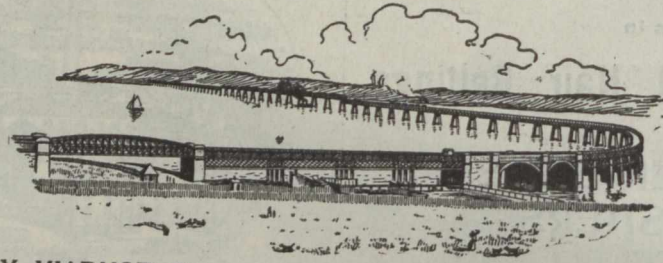

TAY VIADUCT—Opened June, 1867—Length 10,500 feet.

AREA COATED OVER ONE MILLION AND A QUARTER SQUARE FEET.

SPECIAL PRICES TO CANADIANS UNDER THE NEW TARIFF.

WILLIAM BRIGGS & SONS, LIMITED,
DUNDEE, - - Scotland.

Telegraphic Address:
 "HASTE, BRAMLEY, LEEDS."

Haste & Brown,

Hough End Tannery.

BRAMLEY, LEEDS, - Eng.

—Tanners, Curriers,—
 Enamellers & Japanners.

Russet Lining Bellies and Shoulders, of Light
 Substance, Soft, Bright and Dry Finish.

ENAMELLERS and JAPANERS of the finest goods
 in ENAMELLED and JAPANED LEATHERS in
 SHOULDERS and HIDES, SEALSKINS and CALF
 SKINS in Black and Colours.

NOTE.—The "Eagle" Perfection Brand is the motto for the High-
 class Standard of Selection and Quality in these Goods.

Enamelled Shoulders. Enamelled Sealskins. Enamelled
 and Japanned Hides. East India Kips, Offal, etc., Waxed or
 Russet Kip Butts. Levant Kip Shoulders and Bellies.
 Levant Imitation Seal Grains. Split and Russet Shoulders
 for Enamelling. Japanned Shoulders (in black and colours).
 Japanned Seal Splits. Japanned Hide Splits. Waxed Kip
 and Calf Butts. Rough Kip Butts for Laces or Waxing
 purposes. Large assortments always on hand. Stained
 Hide and Kip Bellies, etc., to any shade and requirement.

Cut will be inserted next week.

Telegraphic Address: "Rees, Dundee."

WM. REES & CO., LTD., The Dundee Tin and Sheet Metal Works
 DUNDEE, SCOTLAND.
 MANUFACTURERS OF Oil Drums, Tapers, Paint & Ink Kegs.



Oil Drum.



Plain Keg.



Hooped Keg.



Taper Can.



Tins for Biscuits, Jams, Coffee, etc., and Confectionery Tins of every description.

Lever-top Tins for Paint, Enamel, Syrups, Soap, &c.; Oil and Varnish Cans; Tin Canisters of every description for Dry Goods.



Quality Guaranteed. Prices on Application. Contractors for every description of Tin and Sheet Metal Goods.

✦ CRAWFORD & SONS, ✦

ESTABLISHED

1813.

BISCUIT

EDINBURGH,

Manufacturers,

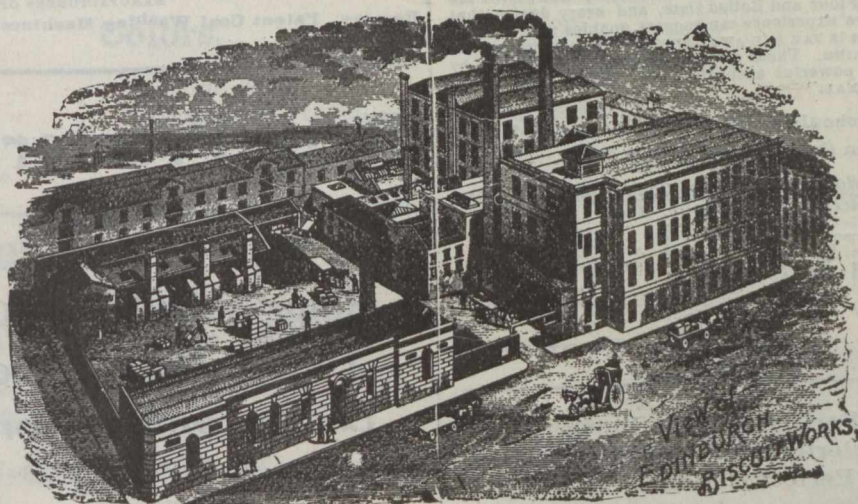

SCOTLAND.



DUNVILLE'S
 OLD IRISH
WHISKY.

Established 1808.

Dunville & Co., Ltd.,

Are the Largest Holders of Whisky in the World.....

Royal Irish Distilleries, BELFAST, IRELAND.

o o o

Their Celebrated Whisky is Manufactured from the Choicest Materials only, and It Stands Unrivalled for Purity and Quality.

SOLD EVERYWHERE.

24 PRIZE MEDALS AWARDED



WALKER'S BISCUITS & CAKES
 JOHN WALKER LTD ROYAL BISCUIT FACTORY, GLASGOW.

Makers of all Varieties Suitable for Export.

SCOTLAND.

JOHN INGLIS & SONS'
GenuineMidlothian Oatmeal
and Rolled Oats (Steam Cooked)

As supplied for many years to H.R.H. The PRINCE OF WALES,
THE VERY BEST THE WORLD PRODUCES.



Facsimile of Tin for Export.

Our mills are furnished with the most modern machinery known for the Production of Oatmeal, Oat Flour and Rolled Oats, and every device that science and upwards of 60 years' experience can suggest, enables us to declare that the quality of our products is FAR AND AWAY SUPERIOR TO ANYTHING YET ATTEMPTED IN OATMEAL MILLING. These statements are fully borne out by the recommendation of such powerful authorities as "THE LANCET" and "THE BRITISH MEDICAL JOURNAL."

Canadian Storekeepers should avoid substitutes and Indent for **INGLIS' Midlothian Oatmeal and Rolled Oats**

Packed for Export in 280 lb. Sacks, 140 lb. Bags, 41b., 71b. and 141b. Tins ; also in 2 lb. Packets ; 50 and 100 lb. Kegs.

John Inglis & Sons' (ESTABLISHED 1838)

The Original Manufacturers of **Leith, Scotland.**
MIDLOTHIAN OATMEAL.

MacLaine's Patent Perfect Safety Battle Ships.
MacLaine's Patent Perfect Safety No. 2 Pistons.
MacLaine's Patent Perfect Safety Tail Shafts.

MACLAINE'S PATENT PERFECT PISTON
 Company, Limited.

CAPITAL £100,000 FULLY SUBSCRIBED.
 24, ULSTER CHAMBERS, - - BELFAST, IRELAND.

EVERYTHING in the line of **JOB PRINTING** executed promptly at the office of **The JOURNAL of COMMERCE.**

Telegrams: "RUBBER COMPANY, NORTH SHIELDS."

The North Eastern Rubber Co.

Manufacturers and Dealers in all Descriptions of

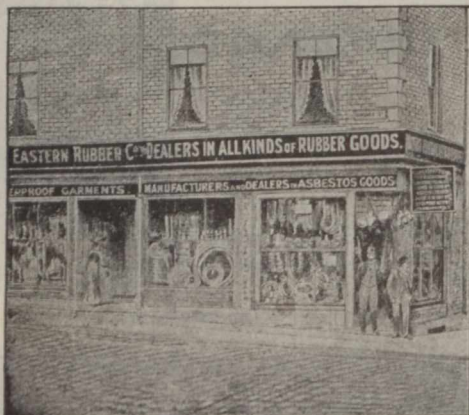

India Rubber,
 Asbestos,
 Leather Goods,
 Waterproof Garments,
 Buffers,
 Valves Packings,
 Belting,
 Hose,
 Tubing,
 &c., &c.

26, 27 and 28 Gardner Street and Borough Road,
NORTH SHIELDS.
 and Fowler Street, South Shields, - - England.

JOSEPH COOK, SONS & COMPANY, LTD., Engineers,
 Iron Founders and Iron Merchants, Truck,
 Wagon and Colliery Tub Builders, . . .
WASHINGTON, CO. DURHAM, ENG.

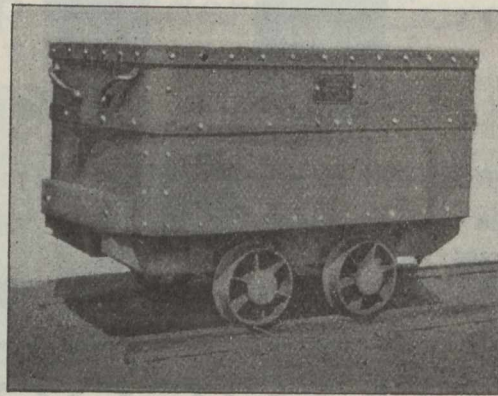

Manufacturers of Forgings & Malleable Iron Work of every description, Shovels, Nails, Chain, &c. Crucible Cast Steel Wheels & Carriages of every Pattern. Sole Manufacturers of Bailey's Patent Dead Lock-Fast ending for Wheels & Axles. Pit Heaps, Pully Frames, &c., erected in either Wrought or Cast Iron or Wood. Steel Pit Cages, Screens for Separating Coal, Teaming Cradles and Creepers Cage Shoes, Coal Screens & Screen Bars, Axles, &c.

Endless Belts for Cleaning Coal. Also Patent Revolving
 MANUFACTURERS OF
Ramsay Patent Coal Washing Machines and Patent Coal Wedge.

Thos. Proctor & Son,

Makers of

Ships' Ventilators, Coamings,
'Tween-Deck Tubes, Signal Lamps, Smith Work, &c. . . .

ENGINEERS' TOOLS, SPADES AND SHOVELS.

23 to 29 Side Newcastle-on-Tyne,
England.

Telegrams: Procurotor, ' Newcastle.

Works: GATESHEAD, ENGLAND.

ESTABLISHED 1777.

OIL MILLS.

On Anglo-American & other Systems, for every kind of Oil Seed & Nut.

COMPOUND FEEDING CAKE MILLS.

HYDRAULIC RAM AND PUMP LEATHER PACKINGS.

THE KINGSTON PATENT

Grab Dredgers

- AND -

Excavators.

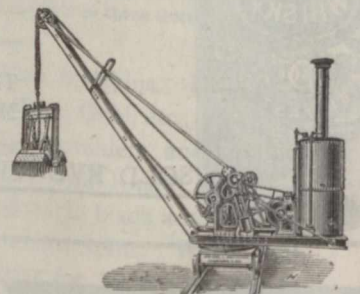

Sole Manufacturers and Patentees :

ROSE, DOWNS & THOMPSON, Limited,

Works: Hull, Eng. ALSO AT 12 Mark Lane, London, E.C., Eng.
 74 Cortlandt St., New York.

Catalogues free in English, French, German, Russian and Spanish.

CONTRACTORS TO HIS MAJESTY'S GOVERNMENT.

SHARP, WORSNOP & CO., Ltd.

Telegraphic Address:
"SHARP, WORSNOP, WYKE."

Aniline Color Manufacturers,
Flash Pond Chemical and Explosive Works,

Latest Makers of Pure
Picric Acid and Pic-
rate of Ammonia. . . .

WYKE, nr. Bradford, Eng.

MANUFACTURERS OF

Chemicals.

Picrate of Ammonia
Spirits Salts
D. O. Vitriol
Nitrate Iron
Special Iron
Muriate Tin
Nitric Acid
Blue Spirits
Scarlet Spirits
Finishing Spirits

Colors.

Ammonia
Crystals
Copperas
Palm Oil Soap
White Soap

Picric Acid
Bismarck Brown
Chrysoidine
Magenta Crystals

Magenta (Acid)
Scarlet
Acid Red
Orange
Acid Yellow
Soluble Blues
Green
Violet

Extracts.

Logwood Extract

Fustic Extract
Myrabolam Extract
Indigo Extract

Dyewoods.

Logwood
Fustic
Barwood
Peachwood
Camwood
Ground Myrabolams

Registered Telegraphic Addresses: "Haggie, Newcastle-on-Tyne"; "Haggie, London"; "Haggie, Hull"; "Haggie, Cardiff."

R. HOOD HAGGIE & SON, LIMITED,

Willington Patent Hemp
and Wire Rope Works,

NEWCASTLE-ON-TYNE, ENGLAND.

Head Office and Postal Address:
NEWCASTLE-ON-TYNE, ENG.

BRANCHES: London, 35 Lime Street, E.C.; North Shields
29 Clive Street; Hull, Victoria Pier; Car-
diff, Burt Street.



SPECIALITIES:

FLEXIBLE STEEL HAWSERS, MANILLA ROPES COIR AND HEMP
ROPES, WIRE RIGGING STEEL AND IRON WIRE ROPES
FOR MINES AND ENGINEERING PURPOSES.

Driving ropes of all kinds, Sisal, New Zealand, and other sorts of
Packing Cords and Baling Ropes.

Five Highest Medals Awarded for Excel-
lence of Manufacture.

ALL STEEL HAWSERS GUARANTEED
UP TO LLOYD'S TESTS.

Large Stocks always ready. Export Orders care-
fully and promptly executed.

TYNE WIRE ROPE MANUFACTURING CO., LTD., TYNE DOCK, ENGLAND,

Manufacturers of all kinds of

..WIRE ROPES..

FOR

Collieries, Engineering, Shipping & General Purposes.

WM. R. STEWART,

Hillbank Hackle W'ks, Dens Road, DUNDEE, Scotland.

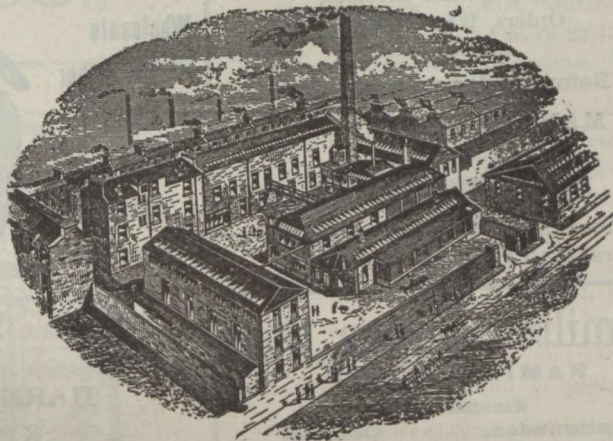

Manufacturer of

Hackles, Gills and Wood's Card Covering

For the FLAX, JUTE and HEMP TRADES

STEELFACED CARD COVERING A SPECIALTY.
Gill and Card Pins, Rivets, &c.

Charles Wood, Limited,

Tees Railway and . .
Engineering Works.

Middlesbrough, - England.



Manufacturers of . . .

Coal Mining Plants and Tipping
Wagons of all Descriptions with
Rails.

Leading Manufacturers &c.

D. MORRIGE, SONS & CO.

MONTREAL and TORONTO.

Manufacturers' Agents and General Merchants,

The Canadian Colored Cotton Mills Co., Montreal,

MILLS AT

Cornwall, Hamilton, Merritton, Milltown, Gibson Cotton Mill, Marysville, Hamilton Cotton Co.

Shirtings, Gingham, Ticks, Cottonades, Oxfords, Denims, Flannelettes, Yarns, Awnings, Dress Goods, Sheetings, etc.

THE PENMAN MANUFACTURING CO., PARIS.

Mills at Paris, Thorold, Port Dover, Coatcook. Ladies' and Gent's Wool and Cotton Underwear, Topshirts, Socks, Hosiery, Balbriggans, etc.

THE AUBURN WOOLLEN MAN'FG CO. PETERBOROUGH.

Tweeds, Beavers, etc.

WHOLESALE TRADE ONLY.

Leading Manufacturers, &c.

JAMES A. CANTLIE,

NEW OFFICE:

22 ST. JOHN STREET, Montreal, Que

Same Telephone No. 341 MAIN.

Kindly Alter my Address in the Telephone Directory.

CAMPBELL'S QUININE WINE.

It will tone up your system, and restore the appetite.

The best cure for Debility.

JUST WHAT

YOU NEED

THIS SPRING.

THE CANADIAN . . . JOURNAL of COMMERCE

Do you want any Printing this week? Our Job Department has every facility for turning out work promptly. Telephone, Main 238.

171 ST. JAMES STREET, MONTREAL.

See our

LOOSE LEAF LEDGER, (Miller Patent.)

....ALSO OUR....

Binders & Sheet Holders,

For Duplicate Invoices, Orders, Way Bills, etc.

Before ordering elsewhere.

WE MANUFACTURE.

* **MORTON, PHILLIPS & CO., ***

Stationers, Blank Book Makers and Printers. 1755 & 1757 Notre Dame St., Montreal.

Hamilton Cotton Co'y

HAMILTON, ONT.

Manufacturers of

Cottonades, Denims, Warps and Yarns, Lamp Wicks, Twines, Webbing, &c.

S. & H. BORBRIDGE

OTTAWA, Ont.

186 Sparks St.

88-94 Rideau St.

15-23 Mosgrove St.

Wholesale Branch at BRANDON, Man.

Wholesale Leather & Saddlery Hardware.

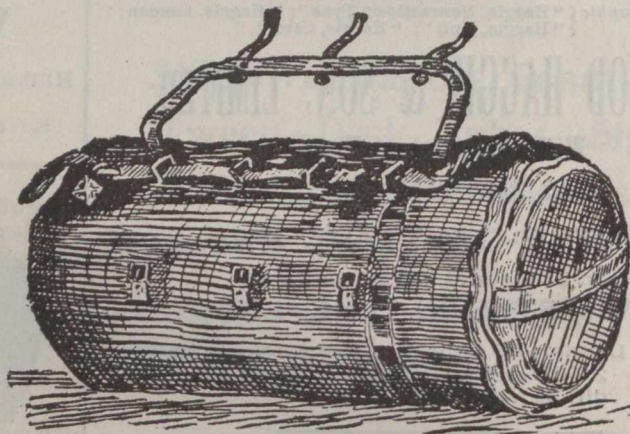

Wholesale Robes & Fur-coats.

Manufacturers of all kinds of

HARNESS, SADDLERY, HORSE-BLANKETS, KIT-BAGS, TRUNKS, BAGS, VALISES. MOCCASINS, &c.

Best for Table use

CAMBRIAN VINEGAR

PURITY GUARANTEED

MALT VINEGAR LEEDS BREWERY

Special Prices to Canadians under the New Canadian Tariff

MONTREAL

MERCHANTS AND MANUFACTURERS.

Awnings, Tents Tarpaulins, Flags, Etc. Thos. Sonne.....198 Commissioners St.

Builders' and Contractors' Supplies.

W. & F. P. Currie & Co....134 McGill St. W. McNally & Co.....50 McGill St.

Carpet Beating.

Dominion Steam Carpet Beating Co., 11 Hermine St. H. N. Tabb, Mgr.

Dry Goods, Wholesale.

W. R. Brock & Co.....26 St. Helen St. Alphonse Racine & Co. 340 & 342 St. Paul St

**Canadian Colored Cotton Mills
Company.**

Cottonades, Tickings, Denims, Awnings,
Shirtings, Flannelettes, Gingham,
Zephyrs, Skirtings, Dress Goods,
Lawns, Cotton Blankets, Angolas,
Yarns, &c.

Wholesale; Trade only Supplied.

D. MORRICE SONS & CO.,
AGENTS,
Montreal and Toronto.

W. J. JENKINS & Co.,
Belfast, - Ireland,
MANUFACTURERS OF
HANDKERCHIEFS and FANCY LINENS.
Washing Suits and Blouses.

STORAGE
(FREE OR IN BOND)
FINLAYSON & GRANT,
CUSTOMS BROKERS,
418 to 417 St. Paul Street, Montreal
Bell Telephone Main 1808 P. O. Box 684.

JOHN E. HARDMAN, S.B.
Consulting Mining Engineer,
Room 3, Windsor Hotel, MONTREAL, QUE
20 Years' Experience in the Mining and Reduction
of Gold, Silver, Lead and Copper.
13 Years as a Specialist in Gold Mining and Milling

GEO. GONTHIER,
Bell Tel.:—Main 2113, Accountant & Auditor.
SOLE REPRESENTATIVE FOR THE PROVINCE OF
QUEBEC OF
The ACCOUNT, AUDIT & ASSURANCE Co., Ltd.
OF NEW YORK.
11 & 17 Place d'Armes Hill, MONTREAL, QUE.

Commercial Summary.

Merchants, Manufacturers and other
business men should bear in mind that the
"Journal of Commerce" will not accept ad-
vertisements through any agents not specially
in its employ. Its circulation—extending to
all parts of the Dominion—renders it the
best advertising medium in Canada—equal
to all others combined, while its rates do not
include heavy commissions.

—A branch of the Dominion Bank
has been opened at Gravenhurst, Ont.

—The National Iron Works at Wing-
ham, Ont., were formally opened on
the 31st ult.

—The customs import duties for
July at Kingston, Ont., were \$9,311.43;
the inland revenue collections were
\$15,745.82.

—The Customs of Montreal collect-
ed last month were \$937,432, a decrease
of \$46,973 as compared with the corre-
sponding month of last year.

—The by-law to grant a loan of \$7-
000 to Wm. McGregor of Juelph to es-
tablish a carpet factory at Forest,
Ont., was carried on the 2nd instant,
by a vote of 284 for and 14 against.

—The inland revenue returns at the
port of Hamilton for July were \$61,-
641. In July, 1900, the returns show-
ed \$52,257, increase last month, \$9,-
383. The licenses last month amounted
to \$1,955.

—The insurance underwriters have
finished their survey of the steamer
Hero, burned at Belleville, Ont., and
made their award, granting full dam-
ages, \$15,000, to the owners. The
steamer will be raised, and if the hull
is found serviceable, will be rebuilt.

—The wheat harvest in the United
Kingdom has been in full swing for
over a week and from reliable sources
it is estimated that although the qual-
ity is fine, the yield in the most im-
portant counties will be four quarters
to the acre, against the usual five-
quarters. Barley, likewise, is of good
quality, but the quantity is below the
average; and oats are too thin to
make a big crop. The yield of Eng-
lish and Scotch potatoes will be fully
up to the average, while Ireland, pro-
mises the best yield since 1895, which
was a grand year.

There is always genuine satisfaction in knowing that you will get just what
you want when you trust your orders for Printing to us—because we not
only make a special study of the requirements of each order, but also give
due regard to taste and effect

171 St. James St.....

Journal of Commerce.

THIS LITTLE TRADE MARK



ON A SAW GUMMER

Is a guarantee that it is the best Tool on the market for Gumming Saws
and Light Punching.

A. B. JARDINE & CO.,
HESPELER, ONT.

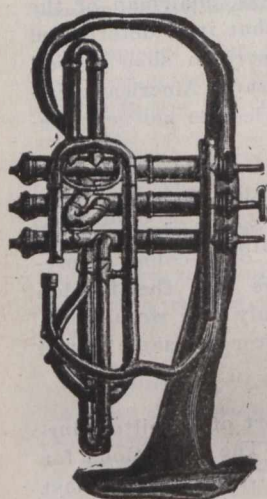

Send 'Em to Douglas'

The most complete Repair
Factory in Britain; also, the
cheapest and most reliable
House in the Trade.

H. D. Douglas & Son,
Manufacturers & Contractors
To Her Majesty's Forces.

36 to 42 Brunswick Street,
Glasgow, Scotland.

Established over Half a Century.

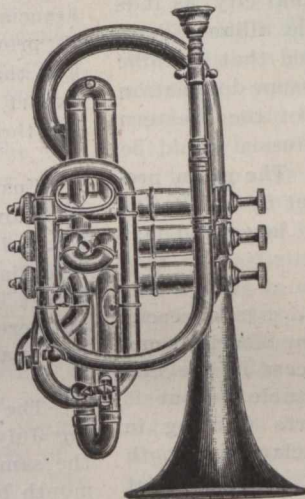

Telegraphic Address : GRANT, KILMARNOCK.

GRANT, RITCHIE & CO.,
Locomotive Engineers, Ironfounders and Boilermakers.

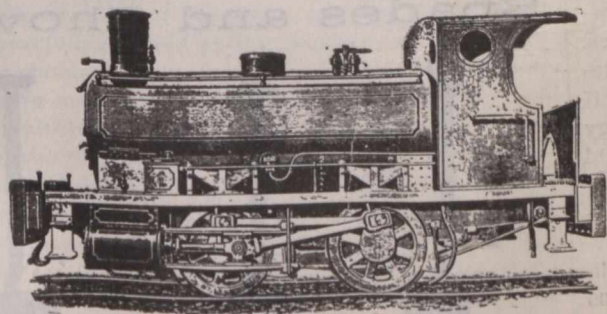

TANK LOCOMOTIVE ENGINE.
Townholm Engine Works,
KILMARNOCK, SCOTLAND.

INCORPORATING FIRMS ESTABLISHED OVER 100 YEARS.

FLEMING'S

The "TEON" BELT is guaranteed to work effectually in Heat, Steam, Damp, Water and Out-of-doors in all weathers.

'TEON'

The "TEON" BELT is unrivalled for high speeds, variable loads and difficult drives.

BELTING.

Fleming, Birkby & Goodall, Ltd., Leather, Hair, Cotton & 'Teon' Belting Mfts. West Grove Mill, Halifax, England,

LARGEST AND OLDEST MAKERS OF CARD CLOTHING FOR FLAX, TOW, JUTE, HEMP, &c., ALSO SILK COMBS.

—Manitoba land sales for the month of July, by the C.P.R. Land Department, amounted to 49,000 acres for \$154,646. This indicates an increase of \$25,163 over the same month last year, when sales amounted to 40,715 acres for \$129,483.

—The telegraph line from Dawson will not be completed until the end of the present month. That portion of the line now under construction passes through very difficult country, and it is stated, may be even later than the end of August before the wire is brought into communication with the rest of the Dominion.

—Ald. S. R. Poulin returned to Ottawa on the 1st inst., from Parry Sound. It is understood he has been awarded the contract for building the McKenzie and Mann railway from Rose Point to Parry Sound. The distance is about three miles. The spur line will connect direct with the Canada Atlantic and the town of Parry Sound. Construction work has already been commenced.

—St. Paul, Minn., advices state that much significance attaches to the visit of Robert Berbier, of the Russo-China Bank and Manchurian Railway to that city, as it is rumoured that preliminaries for a traffic alliance were concluded with J. J. Hill. It is considered that a traffic arrangement with the railways under Russian domination would mean the commercial supremacy of the Western United States in China and Japan, and Russia would be open to the markets of the North-West. The grain products would find a quick and ready market by the Pacific route on which Mr. Hill will put a fleet of large and fast ships.

—Glowing stories are reaching London, says a recent cable, as to the mineral wealth of Eastern Siberia. Americans are working with considerable success in the District of Sretemsk, where a future profitable output is practically guaranteed. American experts working in the gold fields of Siberia and Mongolia declare that both countries contain deposits of wonderful richness, but lying far within desert regions, where transportation is difficult. Americans are also beginning to take a hand in developing the Siberian copper mines, which are believed to be the most extensive in the world. R. M. Gallaway, president of the Merchants' Bank of New York, who has travelled widely in Russia and Siberia, says that the mineral wealth of the latter country is stupendous, and has as yet been developed only in the smallest degree. The lack of railways, he says, alone prevents Russia from becoming the most serious competitor of the United States. The most valuable mineral fields are not capable of development until transportation has been provided. "If the Russians," says Mr. Gallaway, "had half the energy and enterprise of the Yankees the entire country would speedily be honeycombed with railways. The mass of the people is incredibly ignorant and poor, the agriculturists are unskilled, and the artisans are wasting an opportunity unequalled in any country in the world. Siberia possesses a tract of country 1,200 miles long and 300 broad, all virgin soil, black loam ten feet deep, similar to that of the Dakotas, and capable of growing the finest wheat. Given exportation facilities these lands would produce crops that would completely change the aspect of the existing international grain markets."

—The Canadian Commission to the Glasgow Exposition just home reports the Exhibition a splendid success in every way, and states that Canada has a right to be proud of the prominence and excellence of her two groups of exhibits. As to the prospects of increased trade, the commissioner said that a comparison of prices showed that there was in Scotland a great market for Canadian farm products. The prospect for manufactured articles were not as wide. It was found, for example, that certain lines of iron-made articles could not compete with those of Scotch and English manufacture. With certain other lines, however, it was different. There was certain to be a large trade in carriages. As a result of the Canadian share in the Exhibition, a Toronto firm had now an order for carriages to be sent to Johannesburg, South Africa.

—When industrial competition is met by armed resistance it is receiving its best advertisement. A Vienna, Austria, dispatch states that the agitation against the introduction of American shoes is exciting business circles considerably. Government officials, in reply to the appeal of the Shoemakers' Association to prevent American competition, decline to interfere. Herr Bitza, chairman of the association, is credited with saying that it is determined to prevent the establishment of American shoe stores, and that force will be used if necessary. Americans can export and sell shoes in Vienna at prices 30 per cent. below those of the local dealers.

—Customs revenue at the port of London, Ont., for July, 1901, amounted to \$57,845; July, 1900, \$66,818, decrease, \$8,973. July increase of 1900 over 1899, on account of preferential tariff, \$16,677.—The earnings of the London Street Railway for the week ending July 27th were \$3,018, an increase of \$505, or 16.7 per cent. over the same period last year.

—The customs collections for the port of Hamilton during July, 1901, amounted to \$51,680. The collections for the same month last year were \$54,877, the decrease last month being \$2,976.

MATTHEW, REID & CO.,

Kilmarnock Forge, - - KILMARNOCK, SCOTLAND.

Manufacturers of

Spades and Shovels.

Special reduction to Canadians under the new tariff made with England.

Contractors to H. M. Government.

Telegrams: "CUNDALL, SHIPLEY."

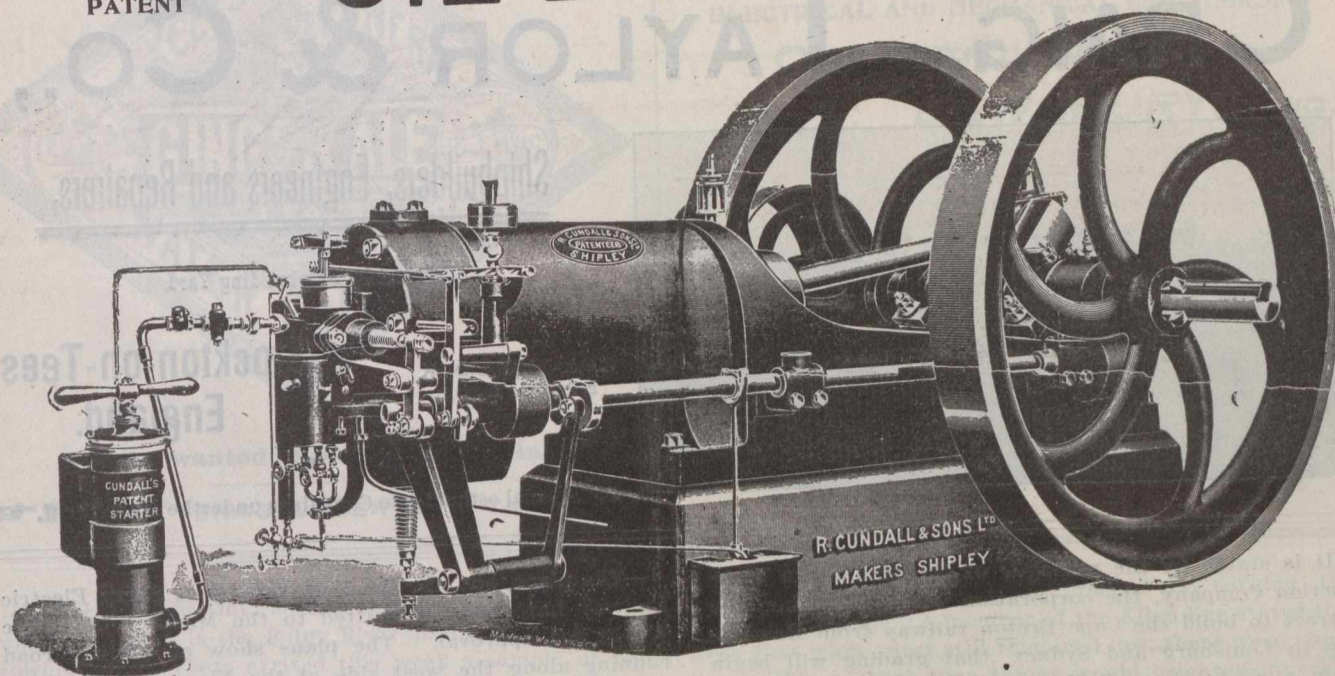
The "CUNDALL"
PATENT**OIL ENGINES**Are the Simplest
Engines Running.

**Economical, Reliable, Easily Managed and Safe.
Makers of the Largest Oil Engines in the World.**

R. CUNDALL & SONS, Limited

**Best Power for FARM, DAIRY, WOOD CUTTING,
MINING, &c.**

**SHIPLEY,
ENGLAND.**

—A special from Hong Kong states that the commissioner of customs has left Wu Chau for Nan Ning, province of Quang See, to open the latter as a treaty port.

—The Customs Department is sending out to the collectors at the various ports copies of a memorandum containing a short form of power of attorney, which, when written, printed or stamped on the face or back of the invoice, and subscribed by the importer, may be accepted for passing an importation of goods at the custom house.

—Washington, U.S., advices state that the Secretary of War has approved an order authorizing the flowage in the the Chicago drainage canal to be increased from 200,000 to 300,000 cubic feet an hour, between the hours of 4 o'clock in the afternoon and 12 o'clock midnight. The flowage formerly was 300,000 cubic feet, but was decreased upon the complaint of vessel owners that such a flowage made the current of the Chicago river too swift and interfered with commerce. The present action is a compromise. It is claimed there are not many boats moving on the river between the hours named.

—A good market for Ontario live stock is of late being found in the prairies of Manitoba and the North-West. From information received at the Department of Agriculture, since January last, Ontario stockmen and horse-breeders have sold \$500,000 worth of horses, cattle, and sheep to Manitoba farmers and Territorial ranchers. Last year, it is stated, one man was sufficient to accompany the carloads of stock going to the West, but this year the shipments were so numerous that three and four men had to be employed. The business done by Ontario breeders in the West is so important that special rates have been secured for Western breeders to visit the Provincial Winter Fair and Fat Stock Show at Guelph in December. It is expected, also that the number of Maritime Province men visiting this fair will also be increased this year.

—The Hull Electric Railway, whose line operates between Ottawa and Aylmer, has, says an Ottawa dispatch, practically passed into the hands of the Ottawa, Northern & Western Railway. The basis of agreement of sale, has, it is learned from official sources, been agreed upon, but before the papers can be signed and delivered, legislation to overcome some provision in the charter requires to be obtained. This will be applied for at the next session of Parliament. The consideration is over one million dollars in cash and bonds. The negotiations for the purchase of the road have been conducted conjointly with those relating to the running of cars over the Interprovincial bridge. In acquiring the road the O., N. & W. Railway is incidentally relieved of the necessity of building a line in from Aylmer in connection with the Pontiac division, for the trains can run in over the electric line, which is equipped with the regulation heavy rails. It is understood that this service will be inaugurated the beginning of the present month. The O., N. & W. Railway, it is stated, will take over the entire rolling stock, and assume the whole management.

—In a recent issue of the Canada Gazette a proclamation appears declaring the Pacific Cable Act of last session to be in force and effect from and after the 1st instant. This act pledges Canada to contribute five-eighths of the total cost of the Pacific cable, providing it does not exceed \$2,000,000. The idea of bringing it into force by proclamation was the outcome of the action of the State of New South Wales in making concessions to the Eastern Extension Company, which at the present time has the monopoly of the cable services to Australia. The Dominion Government has not received very satisfactory assurances on the point, but in view of the recent action of the Imperial Parliament in passing the cable appropriation bill Canada waives its objections.

—An annex will be built to the Canadian Pacific Railway elevator, Fort William, Ont., increasing its capacity to a million bushels.

Telegraphic Address :
 "CRAIG TAYLOR, STOCKTON,"

Oil & Passenger Shlps,
 Twin Screws, &c.

CRAIG, TAYLOR & Co.,

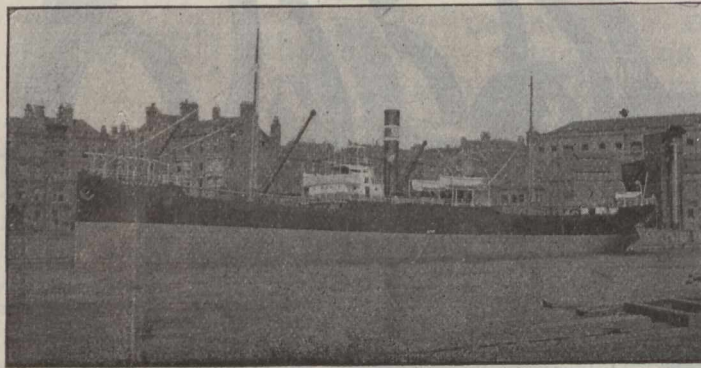

Shipbuilders, Engineers and Repairers,

Thornaby Shipbuilding Yard,

GRAVING DOCK
 570 Ft. Long.

Stockton-on-Tees,
 England.

Special estimates to Canadians under the New Tariff.

—It is stated by the manager of the Manhattan Construction Company, the corporation which has taken the contract to build the Cape Breton railway from Hawkesbury to Louisburg and Sydney, that grading will begin within a week, that all the rails of the line from the Strait of Canso to St. Peters, have been purchased, and quite a quantity landed. Eighty-pound rails are being used.

—An interesting decision was recently given in the Texas Civil Court of Appeals in regard to the liability of an individual for retaining misdelivered letters. The case tried was on account of a letter addressed to the plaintiff, which was delivered by a mistake to the defendant, both having the same name, Cohen. The defendant, instead of at once returning the letter to the post office, kept it for several days, and the plaintiff claimed that this delay resulted in his not being able to sell certain property which, he satisfied the court, would have been sold but for the retention of the letter. On these facts the court held that the defendant was liable to the plaintiff for the damage sustained by the latter.

—The exports of Canadian wood pulp to Great Britain show satisfactory gains, with the further gratifying fact that present conditions are favourable for a much larger percentage of gains in this direction in the near future. The following figures show the relative position of Canada, as compared with other sources of supply for Great Britain's requirements:

Norway	128,455	£ 550,630
Sweden	49,271	401,045
Canada	33,757	162,822
United States	6,741	54,400
Other countries	6,454	52,003

The shipments from Norway and Sweden have fallen off very materially, the reduction in quantities being, respectively, 12,759 tons, and 6,399 tons from the 1900 figures. The depreciation in the value of Norway's export was over £90,000, though Sweden's showed an addition of over £24,000, which is accounted for by the higher range of prices obtained. Canada has shipped nearly 15,000 tons more during this period, at an increased value of over £88,000, which amount practically balances the falling off in Norway's. The latest British Board of Trade reports give the following figures, showing the growth in Canada's trade in quantities and values during the month of May, for the years 1899, 1900, and 1901:

1899	1,768	£ 5,632
1900	3,150	14,447
1901	5,614	23,340

In May, 1899, Canadian exports were five per cent. of the total quantity imported by Great Britain; in May, 1900, they were 7½ per cent. of the total, and in 1901 they were 13½ per cent.

—The plans, etc., for the Fort Erie, Ont., Ferry Electric Railway have been submitted to the Minister of Public Works for approval. The plans show an electric road running along the west side of the Niagara River from Chippewa to Fort Erie. By the terms of the 21-year charter which the company secured at the session of 1900 the company is to buy sufficient land where required to make the roadway along the bank 66 feet wide. The 26 feet nearest the river is for the company's tracks, and the company is to build a wagon road on the inner 40 feet, which after construction is to be kept up by the municipalities. During the 21 years of its franchise the company pay to the Government a ground rental rising from \$1,000 per year in the first few years to \$2,000 in the concluding years. The length of the railway is about 20 miles.

—Letters patent of incorporation have been issued to W. H. Wyman, A. Mercer, H. A. Beatty, and R. D. Chipp, of Montreal, and Robert Neill of Peterboro', as the Semi-Ready Clothing Company, with headquarters at Montreal, and a capital stock of \$200,000.—Letters patent have been issued incorporating R. T. Hopper, R. C. Smith, F. A. Johnson, and F. H. Markey, of Montreal, and John G. Turiff of Ottawa, as the Standard Asbestos Company, with a capital stock of \$150,000.

—A new schedule of railway rates on grain between Buffalo and New York city, has been announced to be in effect until Sept. 1, showing an advance of ¼c per bushel. The new rates are: Wheat, 3¼c; corn, 3½c; oats, 2¼c, and barley, 3¼c.

TYNE IRON SHIPBUILDING COMPANY, LIMITED,
 Steel and Iron Shipbuilders and Repairers.

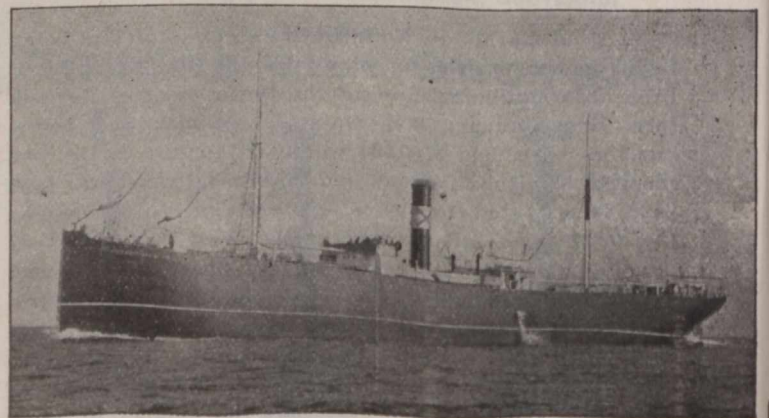

Willington-Quay-on-Tyne,

ENGLAND



Agents wanted throughout Canada.

SPECIAL TERMS UNDER NEW TARIFF.

—A Rat Portage, Ont., special states that Manitoba will soon have a rival in the Rainy River district, in the wheat growing line. There arrived this week a sample of Red Clawson fall wheat, consigned to the Lake of the Woods Milling Company, at Winnipeg, which it would be hard to beat in Canada.

—Michigan saw mill owners are gradually working their way across to the Canadian side. From Sarnia we learn that the Saginaw Lumber Company, which has secured timber limits on the north shore of Lake Huron, are preparing to move their big mill from Saginaw City to the Canadian side. The Cleveland Lumber & Sawing Company have already commenced erecting a mill. They have purchased timber limits in the Township of Foster, on the north shore of Lake Huron. They will give employment to about 200 men.

—Sydney, Australia, advices state that the Commonwealth Immigration Bill, which is to be brought before the Federal Parliament, prohibits the entrance into Australia of any persons unable to write a fifty words' test in English dictation. Furthermore, no person will be admitted who is likely to become a burden on the public purse, or who is suffering from any contagious or infectious disease, or who is imbecile. The bill also prohibits the entrance of any person who within three years may have been convicted of any non-political offence. The exemptions set out in the bill apply chiefly to mariners, and the penalty for breaking the law has been laid down as imprisonment and deportation, while ship-owners convicted of landing prohibited immigrants will be liable to a fine of £100 for each case.

A. HIRST & SON, Limited,
ELECTRICAL AND MECHANICAL ENGINEERS,
CRESCENT WORKS,
VICTORIA ROAD... **DEWSBURY, ENG.**

MAKERS OF

DYNAMOS, ELECTRICAL PUMPS,
MOTORS, HAULING FANS,
RESISTANCES, MACHINERY, SWITCH BOARDS,
STARTING SWITCHES.

And All Kinds of Mining Machinery.

—Ocean freight rates are at present not earning the price of new ships. A member of the Allan line stated this week that while rates still remained low, there were hopes that within a short time things would brighten up. The freight rates in Montreal invariably depend upon the character of the corn crop in the United States. If this turns out satisfactory, freight rates from the port of Montreal can be depended upon. Continuing, it was stated that if for any reason the corn crop proves light or a failure altogether, there is invariably a collapse in the rates from this port. This year there is no doubt that the corn crop will be exceedingly light, and this is the cause of the low rates prevailing at the present time. As regards the conditions of the other export produce rates prevailing at present vessels will likely do a good business in the carrying of apples, which will be a fair crop this year. It is also expected a considerable carrying trade will be done in wheat and oats, as there are large crops of both these cereals. Deals, it was stated, have gone to pieces and there will not be much further business in this line during the present season.

—Hon. Geo. W. Ross, the Premier of Ontario, addressing a meeting recently of the British Empire League at Manchester recently made an eloquent appeal on behalf of the claims of Canada upon the interest of the British people, and declared that British muscle, brain, and money were needed to adequately develop Canadian resources.

—Ninety per cent. of the horses in Chicago are reported to be suffering from influenza. The disease is proving fatal in from three to five cases out of every hundred.

✻ Established ✻ 1825. ✻

A. G. THOMSON & CO., Limited,
Highland Whisky Distillers,

Blenders and Bottlers to Wholesale Trade only.

PROPRIETORS OF

GLENCADAM DISTILLERY, Brechin, Forfarshire,

where the Best Scotch Barley only is used.

Standard Blends of Fine Scotch Whiskies, of all ages from new to 20 years old.

Buyers' own Brands or Labels alone used when desired.

Bonded Stores & Office:—44 to 64 James Watt Street, Glasgow, Scotland.

AGENTS WANTED IN MONTREAL AND TORONTO.



Established 1851.
KIRKER & CO.,
 LIMITED.
 Belfast, Ireland.
 Manufacture
 Ginger Ale,
 Lemon
 Squash,
 Soda Water,
 Kola,
 Champagne,
 &c.

Special prices to Canadians
 Under the New Tariff.
 Cable Address: "BOTTLEERS,
 BELFAST."

Telegraphic Address: "SPIRITS, DUNDEE."



GEORGE MORTON & CO.
 LTD DUNDEE
 SCOTLAND

WHOLESALE WHISKY 24 to 31 Dock St., and
 MERCHANTS DIS- 26 to 30 North Lindsay St.
 TILLERS & BLENDERS.

All communications should be addressed to Head Office, Dock St.



A Safer Drink has
 never yet been
 brewed than . . .

**Watson's
 Dundee
 Whisky**

Undoubtedly the
 Finest Imported.

**Henry J.
 Chard & Co.**

Agents for Canada,

**28
 HOSPITAL ST.,
 MONTREAL.**

—Three consignments of gold, valued at \$10,000, were assayed at the Dominion Government Assay Office in Vancouver, B.C., on the 30th ult. It is stated that the office is equipped with more up-to-date appliances than the assay offices in New York, Philadelphia, San Francisco, or Seattle. Its plant is capable of treating 16,000,000 to 20,000,000 of gold per annum.

—The Department of Agriculture, Ottawa, has placed, on behalf of the Imperial authorities, another order for hay for South Africa, to be shipped in September. Over 10,000 tons will be sent from St. John, N.B., during August, and the September shipment will amount to between 11,000 and 12,000 tons. This will bring the total sent to South Africa from Canada 68,000 tons. All the hay is specially pressed by the Bloomingdale process before placed on shipboard.

—Ottawa advices report consternation among the lumbermen there in consequence of the action of the insurance underwriters in raising the rates on lumber and all extra hazardous risks, such as planing mills, etc. Rates have, it is stated, been raised from 25 to 75 per cent. in some cases. The reason assigned for the increase is that losses on lumber of late years, not in Ottawa only, but throughout Canada, have been exceedingly heavy, that already this year there have been serious losses, and that in future the lumber trade must pay for its own business and the incidental losses.

—Winnipeg advices of the 6th instant, state that best reports of the wheat yield this year come from the Portage plains. The grain on the majority of arms there has grown as thick as it is possible for it to stand, and in a few cases it is too thick and is drooping a little, but cases of this kind are very rare. It would be hard to intimate what the average yield in Portage district will be; 40 bushels to the acre would not be an over estimate. The heads of wheat are well filled, and are beginning to change color fast, and with a week or ten days of bright, warm weather, harvest ought to be in full swing. Some barley has already been cut, but cutting will not be general for a few days. Implement dealers have a large staff of men setting up binders, and getting ready for the rush which is expected next week. Hundreds of these machines have already been shipped to the plains. Farther up the C.P.R. from Bagot to McGregor, the grain seems to be advanced even further than Portage, but it is questionable if the yield will be as heavy. At Morris some farmers are cutting wheat which is fully matured. The yield will be high and of excellent quality. At Gretna wheat cutting commenced on the 3rd and will be general by Monday. New barley threshed yielded 40 bushels per acre.

—The Ontario High Court at Toronto last week gave judgment in Saunders vs the Ontario Bank, an action tried without a jury at Ottawa, to recover damages upon a warranty of 4,500 dozen of eggs, sold by the defendants to the plaintiffs at Ottawa at 13c a dozen. The alleged warranty was that the eggs were in good condition, and of good quality and equal to sample produced. The plaintiffs paid the defendants \$585 for the eggs, and the eggs were delivered, but, as the plaintiff alleged, a large portion was damaged by frost, and they had to sell them for what they would bring, which was 6c a dozen, equal to \$270, and they, therefore, claimed \$315. Held on the evidence, that the sale of the eggs to the plaintiffs was a sale by the defendants through their agent, O'Reilly, whose appointment was sufficient. It was not material whether or not all the warehouse receipts through which the defendants claimed title were such as would technically prove a good title against all comers, or whether or not all the requirements of sub-sec. 2 of sec. 72 of the Bank Act were strictly complied with. The defendants really had the goods, and it was not incumbent upon the purchasers to see that there was a compliance with the Act. The sale made by the defendants' agent, O'Reilly, to the plaintiffs was "a sale by sample," and the implied warranty as to conformity between sample and bulk arose. The eggs in the sample box were good eggs, not frozen, but at the time the sample was exhibited a large proportion of the bulk was frozen eggs. The principal is answerable for every such wrong of the agent as is committed in the course of the agency or services, and for the express benefit of the principal, though no express command or privity of the principal is proved, and in this respect no sensible distinction can be drawn between the case of fraud and the case of any other wrong. O'Reilly was acting in the interest, and for the benefit of the defendants. The defendants are liable to the plaintiffs for the loss they have sustained by reason of the eggs being frozen which, on the evidence is \$315. Damages for loss of profits on a resale of goods are too remote. Interest cannot be allowed because the damages were unascertained and unliquidated. Judgment for plaintiffs for \$315, with costs on the High Court scale.

—We learn from Windsor, Ont., that the initial steps to foreclose a mortgage on the Ontario Glass Works, Kingsville, have been instituted, and the property will be offered for sale by public auction this week. Of late the factory has been running full blast, and if it is removed from Kingsville the town will receive a severe blow. There have been about 50 hands employed in the works. The plant was established three years ago by Detroit capitalists. Recently the controlling stock was purchased by Gordon, the owner of the Wallaceburg Glass Works, which were burned.

"PERFECT" SCOTCH WHISKY.

This Whisky has been well known for nearly a century. During that period it has not varied in character. There is nothing finer in the market. Made solely from home-grown barley, and sold perfectly matured when seven and ten years old.

Special price to Canadians under the new tariff. . . .

J. & R. WILLIAMSON,
:17 Royal Exchange Square,
GLASGOW, - SCOTLAND.



Lang Brothers, Ltd.,

Scotch Whisky
Distillers and Blenders,
GLASGOW & KILLEARN.

Proprietors of

TAM O' SHANTER SCOTCH WHISKY
AND
GOLD MEDAL BANANA RUM.

Distillery . . .
GLENGOYNE, STIRLINGSHIRE,
Offices and Bonded Warehouse:
10 to 20 Oswald Street, GLASGOW,
SCOTLAND.



—Hamilton advices state that Mr. J. P. Steedman, manager of the Gurney Scale Works, for about fourteen years, is purchasing the factory from the Gurney-Tilden Company. He proposes extending the business so as to manufacture other lines in addition, and is backed by local capital.

—Plans for a central railroad station, at Chicago, estimated to cost \$40,000,000, are being prepared to submit to a meeting of railway officials to be held August 15. Eighteen of the twenty two-railways companies with Chicago terminals have approved of the scheme, and members of the Council committee appointed to investigate the question of a single terminal believe the plan can be carried to a successful conclusion. The Illinois Central, Northwestern, Pennsylvania, and Great Western railroads are the only ones which have thus far not given their approval.

—The following limited companies have been incorporated in Ontario: The Bi-metallic Mining & Development Company of Ontario (powers extended to bore for oil, etc.). —The Spadina Country Club, head office, Toronto, capital \$5,000; provisional directors, T. G. Brough, William Ince, C. H. S. Clarke, A. H. Walker, and James William Bain.—The Wright Manufacturing Company of Ottawa, head office, Ottawa, capital, \$10,000.—Caledon Mountain Trout Company, head office Caledon, capital \$99,900. —Keewatin Amateur Athletic Association, head office Keewatin, capital, \$3,000.—The Bradley, Levy & Weston Machinery Company, head office, Toronto, capital, \$40,000.

—A Pacific Coast special states that the greatest enterprise ever undertaken in the Klondike mining district has been started by a syndicate of British and Canadian capitalists, who have obtained from the Canadian Government a concession whereby they are to divert water from the Klondike River at a high point, and to distribute it through flumes and trenches to numerous hill and bench claims, situated along the main creeks in the district. The company is composed of London and Toronto capitalists. Their concession provides that at least \$250,000 must be expended before the end of 1902. The building of the main aqueduct has been started.

—Letters patent have been issued incorporating the following firms: Benamin Spedding, wholesale iron merchant, Montreal; H. Schetagne, notary, Montreal; Ralph C. Thornloe, commission merchant, Montreal; E. H. Gray, manager, Saint Paul, Que.; Chas. O. Clark, belt manufacturer, Saint Paul, Que.; F. Fowler, cheese merchant, Montreal; F. W. Fairman, wire manufacturer, Montreal, to manufacture under the name of "The Quebec Combination Rack Company," with a total capital stock of \$25,000, divided into 250 shares of \$120 each.

—The Canadian Express Company announce the following rates on money orders payable in Canada or the United States, in effect from August 1, 1901: \$5 and under, 3 cents; over \$5, not over \$10, 6 cents; over \$10 not over \$30, 10 cents; over \$30, not over \$50, 15 cents; over \$50 at same rates.

Cable Address :—WENDT, BELFAST,

A. B. C. CODE.

Vint's Irish Preserves.

The Best Old Country Jams to be had.
Made from Irish Grown Fruit.
WARRANTED PURE.

No finer Jams in the world
much cheaper than some...

WM. VINT & SONS,
BELFAST, IRELAND.

SPECIAL TERMS TO CANADIANS UNDER THE NEW TARIFF.
As Supplied to His Majesty's Government.

THOMAS C. KEAY,

Engineer and Machine Merchant,
Mill Furnisher, Shuttle, Bobbin and Picker Maker,
**17 BALTIC STREET,
DUNDEE, SCOTLAND.**

ALL KINDS OF NEW AND SECOND-HAND FLAX, JUTE,
HEMP AND TOW MACHINERY.

SPECIALITIES. — Second-hand machines as above thoroughly overhauled and repaired in first class order.

Maker of Sack Printing Machines for marking in one or more Colours.

SACK CUTTING AND SEWING MACHINES.

All kinds of Shuttles, Pickers and Bobbins for Jute and Linen Trades

.. .. Enquiries Solicited



"Drink the
FAMOUS UNIVERSITY
GINGER ALE
AND
CREAM SODA"

Special Quotation
under New Tariff.

**JOHN HOLMES
& CO.,**
Export Bottlers and
Cordial Makers,
UNIVERSITY AVENUE
Belfast,
Ireland.

Telegrams :
"RESTORATIVE, BELFAST."

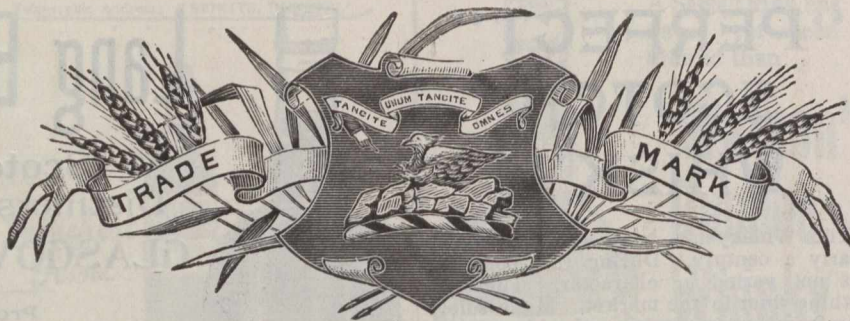

SPECIAL PRICES TO CANADIANS UNDER NEW TARIFF.

"ROSEBANK"
—*PURE*—
SILENT MALT WHISKY,
(Distilled exclusively from the Highest Quality of Scotch Malt.)
**ROSEBANK DISTILLERY, Ld., FALKIRK,
SCOTLAND.**

—A valuator of agricultural machinery imported into Canada has been appointed by the Department of Customs. Mr. James Boughner, of Brantford, has secured the position.

—The Norwegian steamer Vera, from London for Quebec, having water ballast, struck on the rocks near Renew on the night of the 2nd instant, about fifty yards south of the spot where the ill-fated steamer Delmar went ashore and within sight of the wreck of the steamer Lusitania, subsequently proving a total wreck.

—The Canadian Underwriters' Association has, we are informed, issued a new tariff for the Ottawa and Hull lumber yards, and other specially hazardous risks, which will prove a heavy tax on these interests. The underwriters plead in justification that, following the severe losses on lumber last year, already for the six months of 1901 there has been a loss of over one million dollars on this class of insurance in Canada. The association maintains that lumber should pay its own losses, and with that end in view the rates have been largely increased. Ottawa, being the greatest lumbering section in Canada, will especially feel the tax. The following are some of the increases: J. R. Booths lumber yards, from \$2.50 to \$3, \$2.25 to \$3, and \$2.25 to \$2.75 per hundred; W. C. Edwards' yards, from \$2.50 to \$4, \$2.25 to \$4, \$3 to \$4.50, and \$2 to \$2.75. In Hull the rates have also been increased in like proportion. There has also been a heavy increase on saw mills, sash and door factories, pork factories, planing mills, manufactories and other mercantile interests classed as "special hazardous."

—A Johannesburg dispatch states that the Turf Club bore hole struck a main gold reef at a depth of 4,800 feet. This is the most important mining event in years and goes far to prove the reliability of the new South African estimates as to the value of the Rand reefs. It establishes a permanent gold industry for seventy years and practically proves that there are additional deep levels equivalent to the whole line of outcrop mines. Permission has been given to restart another mine, and the Chamber of Mines has selected the Bonanza, which is likely to recommence crushing in three weeks' time.

—The Saginaw, Mich., Lumber and Salt Company has, it is stated, closed a deal with lumber dealers there for 3,600,000 feet of log run lumber, to be cut at the Crow Island mill. The stock is to be cut from Canadian logs. The price is not named, but top figures are realized for that grade of lumber. A week ago the Saginaw Lumber and Salt Company sold 1,500,000 feet of lumber manufactured for this company in the Georgian Bay district, to Chicago parties. The lumber market continues active and strong.

—The shareholders of the Musquodoboit Valley Railway Company, and the Nova Scotia Eastern Extension Railway Company, says a Halifax dispatch, met recently, and decided to amalgamate the companies. Among the shareholders present were Angus McLeod, M.P., for Ontario North, and Mr. Boreland, of Toronto, the latter representing the shareholders in Toronto. The new company will be known as the Nova Scotian Eastern Railway Company.

A. R. THACKWRAY,
Kirkstall Road, LEEDS, ENGLAND.

Manufacturer of All Kinds of

GRINDSTONES

Both Coarse and Fine Grit.

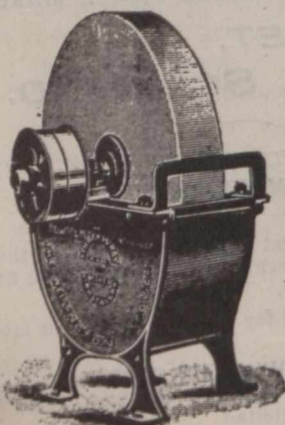

Sole Maker of the **WELLINGTON TROUGH, REGISTERED.**
SEND FOR CATALOGUE OF PRICES.

ROBERT PEEL.

MARSH PUDSEY, near LEEDS, Eng.

Manufacturer of Kitchen Fenders, Fire Irons,
Top Bars, Fire Stands, &c.

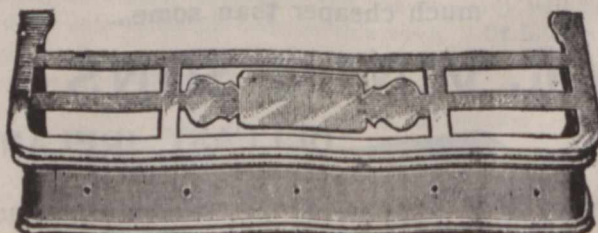

Prices on application.

A. & R. THWAITES & CO.

Inventors of
SODA WATER,
Dublin,
IRELAND.

(Established 1799.)



LIMITED,

Manufacturers to
Her Majesty the Queen
* and *
H.R.H. the Prince of Wales.

—Toronto advices state that the steamer White Star has been purchased by Buffalo agents, and will shortly leave for that city. She has been lying idle this season, but ran last year on the Oakville route. Previous to that she ran to Grimsby Park and other Lake Ontario points. She will be put on the Dunkirk route from Buffalo, and it is expected will share in the Pan-American traffic.

—Mail advices from Wick, Scotland, state that the catch of herring at all the fishing stations along the coast promises to be most successful. The total for all the early stations, the advices state, came to 340,000 crans up to July 6. Including the late Orkney catch but exclusive of the Scrabster, Stromness and West Highlands fishing, the total amounts to 300,000 crans, compared with 200,000 crans for the same period last year. The catch for the previous six years for the same period was as follows:

Crans.		Crans.	
1899	150,000	1896	285,000
1898	250,000	1895	320,000
1897	210,000	1894	390,000
The total catch at Castlebay, Stornoway, Stromness and Scrabster, on the west coast—the season being virtually over—has been as follows, compared with the two previous years:			
Castlebay	16,000	15,000	31,000
Stornoway	39,000	35,000	50,000
Stromness	44,000	3,700	20,000
Scrabster	28,000	3,300	13,000
Total	127,000	57,000	114,000

“Every Factory in Canada should
“use the best Belting. Our
“EXTRA” brand.

The J. C. McLaren Belting Co.

FACTORY:

MONTREAL. TORONTO. VANCOUVER.

—The New York Dock Company, with a capital of \$20,000,000, is, we are informed, to take the place of the Brooklyn Wharf and Warehouse Company. The new company contemplates making improvements on the water front extending from the Brooklyn Bridge south to Red Hook. The company owns about two and a half miles of water front. It is proposed to build a new dock and station with greater facilities than anything of the kind now existing in the United States. The depot will follow, it is stated, in a general way, the plan of the riverside station at Liverpool, the largest in the world. The plans of the company include the use of tunnels to the ocean ships instead of the present method of floats from Jersey City.



FINE COLORS & PAINTS

Established 1848.

FINE COLORS

of all kinds for Printers, Printing Ink Manufacturers, Lithographers, Artists Colormen, Linoleum and Floorecloth Manufacturers, Scenic Artists, Implementation Makers, High Class Painters, Decorators, &c.

PAINTS

Of every description for Painters, Decorators, &c.

VARNISHES

For Coach and Carriage Builders, House Decorators, &c., also Litho Varnishes.

SPECIALITIES:—Holmes' Durable Reds, Permanent Madder Reds, Crimsonettes, Persianettes, Vermillionettes, Lakes, Pulp Colors, Blues, Greens Lime Colors, Drop Blacks, Chromes, White Zinc, etc.

Write for Prices and Samples to Head Offices and Works:

W. H. HOLMES & SONS, Portland Road, Newcastle-on-Tyne, Eng.

LONDON OFFICE:

40 St. John Street, London, E.C., Eng.

THE STANDARD ASSURANCE CO. ESTABLISHED 1825.
OF EDINBURGH.
HEAD OFFICE FOR CANADA, - MONTREAL.

Invested Funds, - - - - - \$48,400,000
Investments in Canada, - - - - - 14,930,000
[WORLD WIDE POLICIES.]

Thirteen months for revival of lapsed policies without medical certificate of five years' existence.
Loans advanced on mortgages and Debentures purchased. Agents wanted.

D. M. McGOUN, Manager.
J. HUTTON BALFOUR, Secretary.

Insurance.

PHENIX ASSURANCE CO'Y
OF LONDON, ENG.

Established in 1761. Canadian Branch Established in 1864.

No. 164 St. James St.
MONTREAL, P. Q.

PATERSON & SON,
Agents for the Dominion

City Agents:
E. A. Whitehead & Co. English Dept.
G. A. Raymond & Co. French Dept.
S. Mondou.

Successful Management

From commencement up to January 1st, 1900, the CANADA LIFE ASSURANCE COMPANY has paid or credited policy-holders, or their representatives, with \$116 for every \$100 which has been paid in, besides defraying all expenses of management. This splendid record is one of the evidences of that good management which has caused the

Canada Life
To be recognized as **Canada's Leading Company.**

INSURANCE COMPANIES placing orders for Printing should make it a point to get our figures before closing their Fall contracts. We have facilities for handling Insurance work to the best advantage and are thus enabled to give our customers the benefit. If you are interested in any way write, or come and see us,

JOURNAL OF COMMERCE JOB DEPT.,
111 St. James Street, MONTREAL.

NORTHERN ASSURANCE CO'Y.
INCOME AND FUND (1892)

Capital and Accumulated Funds, :: \$38,355,000

Annual Revenue from Fire Premiums..... }
Annual Revenue from Life Premiums..... } 5,715,000
Annual Revenue from Interest upon Invested Funds..... }
Deposited with Dominion Government for the security of Canadian policy-holders 200,000

Head Offices:—London and Aberdeen.
Branch Office for Canada, Montreal, 1730 Notre Dame St.
Manager for Canada,—ROBERT W. TYRE.



Caledonian... INSURANCE CO.
The Oldest Scottish Fire Office.
Canadian Head Office, MONTREAL.

R. WILSON-SMITH
FINANCIAL AGENT.
Government, Municipal and Railway securities bought and sold. First class securities suitable for Trust Funds always on hand. Trust Estates managed.
STANDARD LIFE CHAMBERS,
151 ST. JAMES STREET, MONTREAL.

THE
Trust & Loan Company of Canada
(Incorporated A. D. 1845 by Royal Charter.)

Capital Subscribed - \$7,500,000.00
Paid Up Capital - - - 1,581,666.00
Cash Reserve Fund - - - 870,375.00

Negotiate Loans on City Property and improved Farms at low rates and on very desirable terms.

Address, THE COMMISSIONER,
THE TRUST AND LOAN COMPANY OF CANADA,
26 St. James St., MONTREAL, QUE.

THE CANADIAN
Journal of Commerce.

MONTREAL, FRIDAY, AUGUST 9TH, 1901.

THE MINING INDUSTRY.

The depressed condition of the mineral industry in British Columbia has induced the Mining Association of that Province to make application to Government for the formation of a Royal Commission to investigate into the condition of the metal industries and to suggest measures of relief. These measures, they assert, are well within the power of the Cabinet since they maintain that the principal drawback they suffer under is the excessive burden of direct and indirect taxation laid upon the mining industry by the Dominion and Provincial Governments, and the interference of unwise labour legislation in the relations between the mine-owners and their employees.

In so far as taxation is concerned they make out a

THE MANCHESTER FIRE ASSURANCE COMPANY.
Established 1824. CAPITAL, - - \$10,000,000

Head Office, MANCHESTER, ENG. Canadian Branch Head Office, - TORONTO.
JAS. BOOMER, Manager.
R. P. TEMPLETON, Assistant-Manager.

C. R. G. JOHNSON, Resident Agent, MONTREAL.
1723 Notre Dame St.

IMPERIAL LIFE ASS'CE CO'Y OF CANADA.		At Jan. 1st, 1901.	Increase in 1900.	%
1.	Total Assets.....	\$1,102,092	18 p.c.	1
2.	Reserves for Policies and Annuities..	597,488	35 p.c.	9
3.	Annual Premium Income	314,410	46 p.c.	9
4.	Interest Income	36,273	32 p.c.	0
5.	Net Surplus over all Liabilities	39,199	23 p.c.	0
6.	Total Insurance in Force	9,226,350	29 p.c.	0
7.	Gross Surplus for the security of policy-holders, \$489,199.61			
8.	Application for new assurances \$2,847,000, of which \$3,107,000 were accepted and \$740,000 declined or uncompleted.			

HEAD OFFICE:—TORONTO, CAN.
E. S. MILLER, Provincial Manager,
Office: Bank of Toronto Bldg. Montreal, Que.

FIRE. LIFE. MARINE.

G. ROSS ROBERTSON & SONS,
General Insurance Agents and Brokers
ESTABLISHED 1865.
* 11 HOSPITAL STREET, *
MONTREAL.
Telephone Main 1277. P. O. Box 2081.

strong case. But in the effort to strengthen it still further they include a portion of the normal burden upon the whole Dominion, which is borne by every Canadian, and is in no sense a special impost upon the prov-

Mutual Reserve Fund Life Association

FREDERICK A. BURNHAM, PRESIDENT.

EIGHTY-ONE THOUSAND POLICY-HOLDERS.

Total Assets, \$12,264,838.21.

THE TWENTIETH ANNUAL STATEMENT

Shows that the 1900 Business Brought

**An Increase in Assets. An Increase in Income
An Increase in Surplus**

...AND...

An Increase in Insurance in Force.

Net Surplus, - \$1,187,617.68.

Total Death Claims Paid since Organization, over
FORTY-FIVE MILLION DOLLARS.

EXCELLENT POSITIONS OPEN in its Agency Department in every Town, City and State, to experienced and successful business men, who will find the **MUTUAL RESERVE THE VERY BEST ASSOCIATION THEY CAN WORK FOR.** Further information supplied by any of the Managers, General or Special Agents in the U.S., Canada, Great Britain or Europe.

Home Office, Mutual Reserve Building, - - NEW YORK CIT

Montreal Office, - - La Presse Building.

T. W. P. PATTERSON, Gen. Mgr.

UNION ASSURANCE SOCIETY OF LONDON.

(INSTITUTED IN THE REIGN OF QUEEN ANNE, A. D. 1714.)

Capital and Accumulated Funds exceed, - - \$16,000,000

ONE OF THE OLDEST AND STRONGEST OF FIRE OFFICES.

CANADA BRANCH:

Cor. St. James and McGill Streets, - MONTREAL.

T. L. MORRISEY, Manager

ince. No doubt the per capita rate, for a pioneer population, is an onerous one. But it does not reach anything like the figures they assert. Accepting the fact that the whole white population of the province is 150,000, of whom only about 50,000 are white male adults, their estimate that the burden of taxation is \$104 to \$110 per capita is excessive. In order to arrive at these figures they have included the customs duties paid on goods entering the province which form part of the universal burden and are not confined to British Columbia alone. Eliminating these the amount to be raised for Government purposes is reduced to \$1,394,550, or say, \$28 per white male adult. And, adding \$8 per capita for town and municipal taxation, this would only reach \$36 per head.

No doubt the customs duties do increase the cost of running the mines from 10 to 12 per cent. But this is an item that must be taken into consideration and provided for in estimating the commercial value of mining properties; since it represents British Columbia's share of the general burden of taxation. The other provinces bear precisely the same burden without complaint. And to exempt British Columbia from the payment of duties would be both impossible and unfair. So long as British Columbia enjoys all the advantages of membership in the Dominion so long must she assume her share of the cost of its government and expansion. She has received her full portion of national expenditures. And she must bear her full share of national liabilities.

The tax of two per cent. on the output of the mines is, however, an item which the Government might fairly reduce, or abrogate, in the present depressed condition of the industry. The effect of this tax is practically

to appropriate from 6 per cent. of the profits on medium grade ore to 12 per cent. on low grade ore. This prevents the mining of low grade ores profitably; and experience has shown that in all mining regions it is the low grade ores which form the most powerful factor in establishing the industry on a permanent basis. The heavy fees on the registration and incorporation of mining companies, for boiler inspection, land titles, mineral claim records, timber dues, and mining licenses, are also points that the Government could deal with.

The effect of oppressive labor legislation is one which will have to be recognized and put up with. The value of the labour vote in a restricted community usually results in legislation of this character. And it is legislation with which the Dominion Government cannot interfere. The eight-hour law increased the cost of underground labour 16 per cent., the Provincial "Master and Servant Act" practically prohibits the employment of labour from any other province, and the "Alien Labour Law" prevents the hiring of skilled miners in the United States. These statutes are copied from the United States, and are the same as are in force in the mining districts across the border. The difference in their pressure there and here depends upon the fact that there is abundance of skilled mining labour within the limits of the United States, whereas it is comparatively scarce in Canada.

Altogether, then, it does not appear on the surface what good a Royal Commission could do. It cannot interfere with provincial legislation, it could not abrogate either customs or local taxation, it could only reiterate complaints which have already been fully exploited in the mining press. The depression in the mining industry of British Columbia is due partly to economic causes and partly to the inevitable reaction after the unhealthy "boom." But the losses have fallen principally upon Eastern investors. And if the millions of money lost in unprofitable mines has benefited any one at all, it has certainly been the inhabitants of the province in which it was spent.

THE MOTIVE OF THE STRIKE.

Owing to the more or less technical language in which the various ultimatums issued by the United Steel Co. and the Amalgamated Association have been couched, the public mind seems to be a little confused as to the true point at issue. The trouble really began two months ago in a non-union mill at McKeesport, when the Association demanded that the managers deal with them in arranging the wage scale as representing not only the union but the non-union workmen. In other words the Association demanded that it should fix the wage scale on behalf of wage earners who owed it no authority, and who had not asked it to take charge of their interests, as well as for those who did.

To the uninitiated this demand upon the part of the Association to supervise all wage agreements—whether for union or non-union workmen—seems a trifling matter. But for this presumably trivial concession the Association was willing to bring on a strike affecting forty thousand men, with a loss of millions of dollars in wages. Why? Because it recognized that could it once secure the right to fix the wages for non-union men it would have made the first step towards forcing them into the Association. Since in that case it could easily discriminate in favour of its own members in the schedule.

Plainly stated, the underlying motive is the effort to force non-union men into the Association in order to render its equally extensive in magnitude and authority with the great industrial combinations in whose employ its members earn their wages. This power is sought in order that, precisely as the executive committee of a "trust" may at its will alter the volume of production in an entire industry, and fix the amount of dividends, so the committee of a union ought to be able to modify the wage scale, specify the policy of selecting employees, and in an emergency stop all work by the labouring producers equally throughout the whole bounds of an industry.

But we must remember that combinations of labour differ most materially from combinations of capital in their effects upon the public weal. Combinations of capital are subject to the restraints of law. They can be estopped from any action menacing the public welfare, and both in this regard and in the matter of observance of formal contracts they may be held by their property interests, upon which the courts may impose such penalty as is right. These restraints could not hold in the case of what has been called a "labour trust." A union effects its purpose by directing its members to stop work. They are supposed to obey such instructions voluntarily, and there is no way in which the courts can prevent their doing so. How some of them look on the observance of written contracts readers of recent strike news are sufficiently well aware. Civil action against the union is possible for such contract violations; but as the union holds no property, or at best only a small trust fund, the threat of recovering damages has no terror for it.

It results from this situation that a union committee, controlling, directly or indirectly, the action of the whole of the labourers in a given trade, would be able absolutely to stop both production and distribution in that entire industry, and in all similarly situated industries, and in effect to starve out the consuming community. Such an undertaking could not be stopped by process of law. No one can force a man to work. The public's only safeguard is the non-union workman, the free man. Were he eliminated the Association would become paramount. But this is a difficult task. It was the effort to force free labour into the unions that broke the power of Powderly, Irons, Sovereign, and Debs, and which will prove too much for Shaffer also. For the public does not approve of the strike. And no labour movement has ever yet won success in the face of public disapproval. The public realizes that the Association is fighting for control, and not for justice, and that the battle now being fought for the interests of the non-union employees is one which affects their interests directly.

THE NEWFOUNDLAND AND REID CONTRACT SETTLEMENT.

It will be a cause for congratulation to the people of Newfoundland as well as to the people of Canada and the Empire generally that the serious difficulties that have arisen out of the contract made by the Government of the Ancient Colony, with Mr. R. G. Reid, in 1898, which has caused so much hard feeling and has retarded the development of that country, have been finally settled in a manner that appears to be equitable and satisfactory to all concerned, and in a way that may reasonably be expected to result in a more rapid pro-

gress and prosperity of the material interests of the Colony which, we hope, in no distant future, will form a part of the great Dominion of Canada. From its position and, under proper legislation, its commercial interests as well as the general interests of the British Empire, that would seem to be its manifest destiny. And that eventuality is looked forward to by many of the leading statesmen in the countries interested.

Looking backwards it is not surprising that the extremely extensive powers, privileges and grants accorded to Mr. Reid, individually, in 1898, without the sanction of an appeal to the people, raised opposition. They were of an extraordinary character and it is not surprising that when the full bearing was realised the people felt that nearly all the interests of the country were placed in the hands of one man, and that there was practically but little left for the Government of the country to do to promote its advancement.

The result of that feeling was that means were found to bring on a general election, in which that contract was the issue. The opposition to it was led by Hon. Robert Bond, who had before proved himself a resourceful and tactical leader, and the election of last fall resulted in an overwhelming majority against the contract, and as a consequence Mr. Bond became premier of the Colony. Since then Mr. Bond seems to have been untiring in his efforts to obtain a modification of the objectionable features of the contract, and his colleagues in the Government appear to have given him a free hand and a loyal support in the work. Legally, Mr. Reid had apparently a strong case, if he could have carried out his projects as an individual, but in order to swing so large a job as he had undertaken, he deemed it advisable to organize a joint stock company to better enable him to carry out his large operations under the contract. By the terms of that contract the consent of the Government to any transfer of his rights was required. This consent was asked for and refused by the Bond Government, and there was a deadlock. That clause in the contract seems to have been the master key to the whole position, and after months of consultations and negotiations in Montreal, England, and St. John's, an agreement was reached and a Bill has just been passed by the Legislature which was sanctioned by the Governor before the prorogation last week.

We have a full copy of that Bill before us, as well as the Act incorporating the "Reid Newfoundland Company," to which Mr. Reid's rights and privileges as modified from the 1898 contract will be transferred. The capital of the company is fixed at \$25,000,000 in shares of \$100 each.

The Hon. Mr. Bond introduced the Bill in the Legislature in a clear and very able speech—remarkable for its temperate tone in such a heated political atmosphere as that generally prevailing in Newfoundland, and it met with no serious opposition. In the full report of his speech he very lucidly explains the nature of the material changes from the former contract.

Among the chief objections to the first contract was that all the wires and telegraph stations and the whole business of telegraphing in the country was handed over to Mr. Reid. By the new arrangement the whole of that system reverts back to the Government, except his right to have messages affecting his own business transmitted free. Mr. Bond and his friends insisted on this point on commercial grounds, and that, like the post office, it should be entirely free from private manage-

ment, as he said is the case in all civilized countries, except Canada and the United States.

Another important change is in the ownership of the railway at the end of the 50-year term during which Mr. Reid was bound to operate it. Under the first contract Mr. Reid advanced \$1,000,000, and at the end of the fifty years he was to be the complete and entire owner. Mr. Reid abandons that claim, but will continue to operate the road; the Government is to repay the money he advanced, and it will be the owner of the road now and after the 50-year term expires. In connection with operating the railway—apart from the large grants of land for building it—the first contract gave Mr. Reid some 3,300,000 acres of land with a sea coast of nearly 500 miles. This was found objectionable in the public interest on various grounds, as explained by Mr. Bond, and by arrangement that grant is cancelled and for the concession the Government will make a cash payment to Mr. Reid of \$850,000.

Other changes of more or less importance are made, the full bearing of which most people at this distance will not readily understand. The agreement and the Act of incorporation of the new company appear to have been satisfactory, as Mr. Reid's name is attached. The first contract is shorn of many of its important features, but there is compensation to a certain extent, and enough remains to make the privileges, rights and franchise very valuable. All parties will hope that Mr. Reid and his associates will find the undertaking as profitable as they can expect, and that the enterprise of Mr. Reid will be well rewarded.

The country at large will rejoice at the happy termination of this troublesome question. The negotiations that have led up to it appear to have been conducted in a friendly spirit, notwithstanding the delicacy required in dealing with a question in which such large personal interests were involved. Mr. Bond closed his eloquent speech, when introducing the Bill, with the following graceful remarks:

"I have now placed before this House and the country the full scope and meaning of the Bill proposed to be introduced. In so doing I have not been unmindful of the great public interest that is taken in this measure, and the desire to be entirely frank with this House and the public must be my apology for entering so closely into details. Public interest centres in this measure to-day; public interests for all of the future lie wrapped up in its folds. The working out of this measure was left entirely in my hands by my Executive colleagues, entailing an amount of labour and anxiety that has placed my very ordinary resources to a severe test. I have done my best for the Colony, and I trust it will be acceptable to the people. It must be remembered that this is not forced legislation, but is the result of negotiations that have extended over some months. These modifications have not been forced from the contractor by threats; they have resulted from prolonged discussion. What I have kept before the eyes of the contractor and his learned adviser was this position, that in making a demand for the modification of the Railway Contract of 1898, the Government were not actuated by any feelings save those of a desire to conserve the public interest. That the modifications are for the sole purpose of bringing the people into harmony with him, and thus enable the Government to actively co-operate in promoting his enterprises, in the success of which the whole Colony will necessarily participate. This I take it is the end

that we all have in view. I believe, sir, that if this Bill becomes law it will insure mutual confidence, co-operation and a blending of interests as between Government and contractor. I look to this measure as removing all cause for friction between the people of this Colony and the contractor, and as calculated to result in a steadier increase of prosperity, and a steadier wage for our working people. The contract of 1898 aroused the bitterest animosities between politicians as well as between the people and Mr. Reid. This Bill, I earnestly hope, will remove that feeling. It shall be my endeavour at any rate to cultivate this feeling—justice to each other, kindness to each other, respect and honour for each other.

"Mr. Reid has met the public demand in a manly manner; he has respected the vox populi; he therefore is entitled to justice, respect and honour at the hands of the public. He relinquishes his title to the railway for what he paid for it; he might have insisted upon compensation for the loss of its prospective value. He hands back the lands obtained under the 1898 contract for the value that the Government places upon its public lands; he might have insisted upon their value being fixed by arbitration. He does this in the interest of peace and good-will, and in order to secure the co-operation of the Government and of the people of this Colony in making his enterprises a success. Unless I am mistaken as to the character of the people of Newfoundland he shall receive that co-operation; and if the spirit of the sentiment that I have just expressed is caught up by this House and applied, we may look forward to a great and striking and permanent improvement in this Colony before many years shall have rolled away."

AMERICAN RECIPROCITY WITH CANADA.

A committee has been organized in Boston, U.S., to promote reciprocity with Canada. It has forwarded us a report of a number of addresses on this topic delivered at a dinner in the capital of New England. Accompanying the report is a list of 76 commercial bodies, that favour the trade relations of the United with Canada being placed upon a reciprocal basis by, "the largest possible number of commodities the products of either Canada or the States being placed upon the free list of both countries." The list comprises the names of 11 trade organizations in Boston; 3 in New York; 1 in Chicago; 2 in Cincinnati; 1 in Buffalo; 1 in Baltimore; 2 in Detroit; 3 in Philadelphia; 2 in Portland, and the rest in 50 other cities of more or less importance. So large a number of American Boards of Trade, Chambers of Commerce, and trade associations indicates there being a widespread conviction that some improvement is needed in the fiscal policy of the United States.

It is significant that not a single Board of Trade, or any similar body in Canada has echoed the cry raised by 76 such organizations in the United States. The inference is justified, that the business men of America feel the need of extended commerce with Canada more than those of Canada do the desirability of a wider opening in American markets. To what cause must be attributed this movement in the States in favour of reciprocity with Canada? It is directly opposed to the fiscal policy embodied in the Dingley tariff which has received the emphatic endorsement of the people of America by the election and re-election of President McKinley. The reciprocity movement certainly does not owe its inspiration to the Democratic

party in the States, for the larger number of cities in the list, whose trade organizations have passed a resolution in its favour, are those where the Republicans are in control. The period in which this movement was initiated and the business interests, chiefly manufacturing, it represents, indicate that the preferential tariff of Canada in favour of Great Britain is the inspiring cause of the American demand for reciprocity with Canada. Indeed, one speaker at the dinner above alluded to, said: "We are justified in believing that this preferential tariff, ostensibly created for the purpose of showing the patriotism of the people of Canada and their love for the Mother Country, has in it an element of hostility to the United States." The speaker went on to say that, "in regard to cotton goods Canada seems to be in a position to compete on even terms with our own country" (the United States). Although, then, there are those in Canada who, as we pointed out last week, condemn or sneer at the preferential tariff, it is evident that its operation and possibilities have made a profound impression upon the manufacturers and merchants of the States who are represented by 76 Boards of Trade and similar bodies.

Astute and intelligent as are the promoters of this remarkable movement, they seem to have blinded themselves to the fact that, in offering so large a concession to Great Britain as a rebate of one-third the ordinary duties on imports, Canada was setting the United States an example of partial reciprocity which they are now following. Reciprocity is not Free Trade, it is an exchange of fiscal favours; it involves the granting of concessions in return for concessions, which the new movement in the States aims at securing. Now, Canada being unable to grant free imports to England in return for England's open ports to Canadian products, has gone as far as possible towards reciprocity with the Old Country by imposing only two-thirds of the duties on British imports which have to be paid by foreign imports. The causal principle, then, of Canada's preferential tariff is not "hostility to the States," but a desire to exhibit, as far as possible, reciprocity with England.

If, then, the people of America desire to have the preferential tariff extended to their imports they should give Canada equal privileges she enjoys in the ports of England, but until the States are equally liberal in their fiscal policy as is Great Britain they certainly are very unreasonable in objecting to Canada's liberality—her advance towards reciprocity with the old land.

At present Canada has advanced half way to reciprocity with the States without one single step having been taken to meet her advance. The duties imposed on Canadian imports by the States are double the duties imposed by Canada on imports from the States. Canada admits from 50 to 60 millions of dollars worth of goods from the States free of duty, about four times as much as are allowed to enter free from England. The percentage of American free goods in 1899 was 73 per cent. of Canada's total free imports, those from England were only 17.3 per cent. of the total, and from all the rest of the world the free imports into Canada were only 9.7 per cent. of the total. Surely these striking figures demonstrate, that Canada has piped to Americans without eliciting any response.

Before going any further in their reciprocity movement it would be well for our American friends to learn

the exact conditions now existing. Were they to acquire this knowledge and reflect upon it they would laugh at their own audacity in inviting Canada to extend to them, who now charge on our imports double what we charge on theirs, the same privileges which we grant to England that admits all our products free of duty. If the manufacturers, producers and merchants of the United States are in earnest in desiring improved trade relations with Canada they will cease talking about reciprocity with Canada until they have induced the American Congress to reduce the duties on Canadian imports into the States to the level of the duties imposed by Canada on American goods entered in the ports of this country. When that has been done then the question of reciprocity can be taken up consistently. But, until an equality of duties has been so established between the two countries, the American cry for reciprocity with Canada and the complaints made by the States against Canada's fiscal concession to England, must both be regarded as unreasonable to the verge of absurdity.

THE FALL FAIRS.

While yet the harvest is in the field and the sound of the thresher is unheard, the annual exhibitions have begun and, from now till the advent of the earliest snow, with but few intermissions, the instructive and attractive fall fairs will fully serve their purpose in some agricultural centre of the Dominion. Except in a few isolated districts the crops this season will be gathered in greater abundance than for many years. This will help the fall fair. The prices of cheese and butter have been kept well up throughout the entire summer, while eggs, vegetables, etc., have also commanded prices which have permitted more cash purchasing and fewer large store-bills, a gratifying knowledge to the thrifty country housekeepers and one which will admit of an extra day, an extra dollar and possibly an extra exhibit at the fall fair. The abundant early rain caused extra growth in cereals and roots, while the after period, up to the present, has been all that could be desired; therefore, with the exception of those in a few scattered districts, each agriculturist will, doubtless, see in the growth and abundance of his various crops something nearer the perfection which he formerly observed beside the red or white prize ticket at the exhibition of the year before, this urging him on to greater interest both in his yields and in the decisions of the judge at the approaching fair.

In the towns and cities factories and shops have been running steadily, good wages have been paid throughout the year, new enterprises, or additions to those established, have been springing up in almost every county, development of mineral lands and building of new railways and branch lines have drawn any surplus hands from the towns and cities, securing for all who needed it, or would accept it, work at good wages, which has brought general prosperity and a decided relief from want, except where incapacity prevented, all of which has placed the country in a good position for the greater success of the fall fairs. The large factories throughout the Dominion, observing all this and noting the extra expenditure of money which will be a natural result of a prosperous harvest, are correspondingly busy with agricultural implements, pianos and organs, sewing machines, etc., all of which can be readily purchased

and paid for when the farmers are getting good returns; and in order that none may be outdone in the race for preferment, larger space is being secured for exhibits of these at the approaching exhibitions.

All who can should attend the annual fairs, whether county or provincial. The best of all local productions is there displayed, while instruction and a high degree of perfection are to be found at every turn. The retail merchant is, probably, given the greatest chance for benefit as a casual observer at the large exhibitions. His business, whether that of general merchant or confined to a special line, is promoted to a large extent by the window display which he endeavours each week to make as attractive as possible. In the exhibition he observes the best of all the originality that the mind of the exhibitors can conceive; not of one alone, from which he might derive a pointer, but from all. Each has used his brightest ideas for the most attractive display of his wares, and from this multitude, many beneficial ideas may be gathered. The size of the special exhibits is also a knowledge to the retail dealer of the extent to which that particular brand of goods is being advertised, thus serving as an after guide in dealing with the persuasive traveller who would probably make his own brand or production the "only one" being extensively sold and displayed at the exhibitions.

To mix with a dense crowd is in itself beneficial. It serves to remind the millionaire that beyond the accepted knowledge of his bank account, his place is that of one among countless numbers. To the youth who has persistently saved his spare dimes for the past three months in order that he might wear a new outfit and a look of prosperity at the annual fall fair, it reveals the fact that a good appearance to the outside world will gain him an entrance to business or social circles beyond all the knowledge to himself alone of the chances he missed, positions he might have held, or those which circumstance may subsequently throw in his way. He returns home better pleased with his efforts at improvement in personal appearance, for he has seen that the rest of the world is endeavouring to accomplish the same. The manufacturer sees the best productions of his competitor while the stock raiser sees the choicest pick of the fields remote from his own, and probably learns the details responsible for such growth or preference.

The Winnipeg Industrial Exhibition last week, although held at a time when haying and harvesting were in preparation, proved so successful in point of attendance that much difficulty was experienced in accommodation, although ample preparations were thought to have been made. The Toronto exhibition which opens the last week of August promises to far exceed any former result, preparations to that end being now actively under way.

CEMENT WORKS AS A FIRE HAZARD.

The steady increase in the number of cement mills in Ontario, and the recent destruction of a local cement factory by fire, have drawn the attention of underwriters to the amount of fire hazard involved in the manufacture of this indispensable building material. And it is curious to find that the result of investigation has shown that cement works are by no means the desirable hazard that the lay public have hitherto believed them to be. They are certainly occasionally fire-proof, and

are sometimes located within reach of the fire appliances of some town or city. But, as a rule, they are neither. They are usually constructed more for convenience than safety, are surrounded by frame cooper shops and other wooden buildings, and are sometimes veritable fire-traps. Owing to the necessity for locating these mills in close proximity to the natural deposits of raw material they are nearly always partially or wholly beyond the reach of public fire extinguishing apparatus, and as they are often but poorly provided with anything of that character themselves, the prospects of saving them in case of fire are reduced to a minimum.

In most cases cement works are operated continuously, Sundays and holidays included, and thus the machinery has not the usual rest for cooling off, cleaning, and repairing. The grinding mills often become dangerously hot, and the journals and bearings require unusual care to prevent cutting and friction heat from the flinty mineral dust. The temperature in the mill rooms, where the hot cement dust absorbs every atom of moisture from the air, also adds to the risk of fire. Hence while the cement itself is of a strictly non-combustible character, and even retards the action of fire, it can be manufactured only under a high degree of heat and other severe processes in producing the chemical changes required.

There is no class of manufacture in which the nature of the raw material appears more harmless. But it has in reality a number and variety of hazards. The raw material is first dried in stationary or revolving kilns, either by steam or direct fire heat. It is then ground in pulverizing mills. In this form it is transferred to another set of kilns where it is subjected to a heat of 2,000 to 3,000 degrees Fahrenheit, and melted into what is termed "clinker." When rotary kilns are used this clinker is discharged, at a white heat, almost continuously. After being cooled it is again ground into the finished cement. The fire hazard of such a process as this in an easily inflammable building can be readily understood. It is enhanced in those mills of the most modern type, in which the fuel for the clinker kilns is pulverized bituminous coal. In these mills the dried and powdered coal is conveyed from the grinding room to hoppers in the clinker kiln house whence it is blown in a steady stream through 4-inch metal pipes directly into the furnaces. This is the very latest method of producing instantaneous combustion and a quick powerful heat. But its hazard of fire is readily recognizable. The atmosphere of the grinding rooms becomes thoroughly charged with powdered coal. And this, as every one knows, is often highly explosive.

Thus cement works are by no means the excellent risks that the fire-resisting qualities of their product would indicate. No doubt some of them are as secure against fire as it is possible to make them. And others could be easily made so. But there is no class of hazard where the conditions and situation of the different plants vary so much. And hence they cannot be generalized as a class, but require individual inspection by an expert before it is safe to accept them as a risk.

—Sardine factories at Eastport, Me., are having such an unexampled run of herring that notice has been sent to St. Stephen, N.B., for extra help, guaranteeing 500 men, women and children work for several weeks at good wages.

THE INDUSTRIAL STRUGGLE.

Our cousins beyond the border line have been wont to assert—and not without considerable reason—that nowhere else in the civilized world is the efficiency of the workman plus the machine so great as in the United States; simply because in no other country has the workman been so ready to receive the machine in its true character as the result of a long series of carefully directed efforts to increase his own capacity for production and to lighten his work. The success achieved by American manufacturers in producing more cheaply than their competitors (even when paying higher wages), has been due as much to the readiness of the American workmen not only to accept the machine, but to endeavour to increase its efficiency as to the efforts of the employer to keep the machinery in his factory up to the highest standard.

Without this co-operation between employer and employed there would have been no such industrial progress possible in the United States as this generation has witnessed. Consequently the multiplication of strikes, the increasing friction between capital and labour, and the success of labour demagogues in spreading a spirit of hostility between master and man, seems to argue that the old friendly co-operation between the individual master and the workman is disappearing now that the leading industries of America are passing under the control of soul-less trusts and corporations, and the workingman is daily becoming less and less of a human being animated by the same hopes, fears, and aims as his employer and more of a simple cog-wheel in a huge machine.

What this means it is not difficult to see. It was the loss of this wholesome co-operation between master, man, and machine, that has so seriously hampered some of the most important of British industries. It was the quiet progress of trade unionism, dictating to the men not only how long they should work, but how much they should produce, that made the first inroads into Britain's powers of competition in the open market with nations whose workmen helped instead of hindering their production. If the American workman, hitherto free, is going to make the walking delegate the arbiter of his grievances and the judge of the amount of work he is to produce, at a time when the British workman is commencing to see the folly of implicitly obeying the behests of the Unions, we may witness a serious change in the productive situation. We may witness Britain resuming her position as the leader in industrial enterprise before the present crucial struggle between the capitalist and the walking delegate has been finally fought to a finish in America.

No doubt when huge and aggressive corporations are formed to control the productive energy of the country, the workingmen naturally try to extend their own organization. Combination can only be met by combination. When capital combines, so must labour. Productive centralization can be stayed only by a corresponding concentration of the producers. Up to the present the combinations of capital have shown no tendency to reduce wages. On the contrary, they have advanced them, and have shown a marked desire to maintain harmonious relations with their employees. But these are prosperous times. Demand is active, prices are good, and the mills are busy. There is no reason to endeavour to increase the margin of profit by reducing the rate of wages. But will it be thus in dull times?

Can capital afford to be equally liberal when prices are low and the demand slack? Will the shareholders be content to go without dividends in order that the workman may continue to receive high wages? Our knowledge of human nature prevents our answering in the affirmative. Hence the desire upon the part of the labour leaders to push the struggle on now, while the men are earning good wages and those still working are able to contribute to the support of those who are not. They have known all along that this contest must come. And they prefer to enter upon it now, when the treasury is full and the men are prosperous and confident.

Correspondence.

BRITISH MANUFACTURES IN CANADA.

To the Editor of the Journal of Commerce:

Sir,—A Western trade paper—which obviously holds a brief for American manufacturers—writes editorially that certain lines of machinery and steel work cannot be profitably imported from Britain into Canada, first, because they are already manufactured in this country, and, secondly, because they can be purchased to greater advantage in the United States. Among the lines thus tabooed to the English manufacturer are placed electric motors, steam engines and boilers, gas engines, lathes and tools, bridge work and girders.

It is hardly necessary for me to say that both the reasons given for warning English makers of these particular lines away from this market are absolutely erroneous. The first given is sufficiently flattering to the patriotic feelings of a Canadian to be passed over in silence. But with the second I must join issue. None of the lines named can be purchased to any greater advantage in the United States than in England, except under such exceptional circumstances as the deliberate slaughter of American machines in our markets in order to reduce their surplus without weakening the home figures. There have come instances under my own notice in which American gas engines have been sold at half the catalogued trade price in Canada, although they had to pay duty (*ad valorem*) on the price at the principal market in the country where manufactured. There have been cases when engines for which the American buyer must pay \$1,100, have been sold in Canada for \$545 in cash; although the purchaser had to pay duty on the true value. But these cases are not general. And against such deliberate cuts below cost no firm doing business on legitimate lines could compete. When machinery is bought under ordinary circumstances the British maker, backed up by the preferential tariff, is in a position to compete favourably with the American in every line except agricultural machinery. In this line the American manufactures articles as staples which exactly suit our farming methods, while the staple English machines are not so suitable to Canadian requirements, and special lines would require to be manufactured for this market. In agricultural machinery, then, the United States naturally takes precedence. But only in this line. In all others the Briton has precisely the same opportunities as his American rival.

One advantage the American has is his propinquity. This enables him to send out travellers, to deliver goods by rail or boat more promptly than is possible from Great Britain, to adjust disputes orally by his representatives on the ground, and to furnish interchangeable parts more rapidly. Here his advantages end. The Briton has, for compensation, the fact that his goods pay one-third less duty than those of his rival, that his work has the reputation of superior solidity and durability, and that, all things being equal, the Canadian will prefer to purchase English goods than American. The reduction in the duty effectually makes up for the lessened freight his rival

“RED HAND”

ROOFING
Foundation Felts.
Inodorous Felts.
Slaters' Felts.
ARE UNEQUALLED

TRADE MARK.
ON EVERY YARD. ON EVERY ROLL.

FELTS,
Dry Hair Felts.
Silicate Cotton
Patent Hair Fabric.
THE WORLD OVER

Manufactured by
D. ANDERSON & SON, Ltd., Lagan Works, Belfast, IRELAND.
Hand-books with your Specialities, Name and Address, free.
LOYALTY TO THE TRADE IS OUR MOTTO.

has to pay. The other points he can make up by greater attention to the requirements and methods of the Canadian market. If he will send representatives to this market, or establish agencies with sound firms here. If he will quote prices laid down here, instead of f.o.b. at a British port. If he can quote prices as cheap as his American rival; if he will take pains to study this market, he can secure his fair share of the trade. To pretend that the British manufacturer cannot sell engines, lathes, motors, tools or structural steel in Canada because these articles are manufactured here or can be secured in the United States, is simply absurd. Our markets are open to all. And to the Briton we concede a preferential tariff in his favour in order to aid him in entering them. The rest lies with himself—our Western friend to the contrary notwithstanding.

Montreal, August 6th, 1901.

BRITON.

BRITISH RAILWAY DIVIDENDS.

The fall in British railway stocks is obviously due to the unsatisfactory nature of the dividends they have recently been declaring. And these, in their turn, are due to the heavy increase in working expenses owing to the extraordinary rise in the price of coal, and, to a lesser extent, to the increased cost of material and labour. For some time it has been apparent that British railway dividends would be smaller than they were a year ago. Yet the public refused to believe that the decline in the dividends would be quite as great as the very best-informed estimated; and therefore when announcements came that the London Brighton & S. Coast Co. would pay a dividend for the half-year of only $2\frac{1}{2}$ per cent. against $3\frac{1}{4}$ per cent. at the corresponding date last year, there was a general rush to sell British railway stocks. The market had optimistically hoped that the dividend would be 3 per cent.; and when they realized how much greater the losses of the company were than they had believed, a kind of panic seized the market. Since then two other dividends have been declared. The Metropolitan pays $2\frac{1}{4}$ per cent., against $3\frac{3}{4}$ per cent. twelve months ago. This latter company is a purely London affair, and practically carries only passengers; but it is to be noted that the Great Eastern, which carries merchandise as well as passengers on a considerable scale, announces for the first half of the present year only $1\frac{1}{4}$ per cent., against 2 per cent. at this time last year. It is reasonably to be anticipated that the other companies have suffered at least as much, and consequently that all the dividends will show a very great falling off.

The decline in railway dividends makes all the greater impression just now because of the break in the American market which has now lasted ever since the Northern Pacific "corner," and which has caught a good many professional operators with more stock than they care to carry. The great public, it is quite true, did not join in the boom to any very great extent; and, speaking broadly, therefore, the position in London is quite sound; but all the same, a considerable number of big speculators have been hit; and big speculators on the Continent, more particularly in Germany and Holland, have been hit much worse.

AMERICAN PIG PRODUCTION.

The make of pig iron in the United States during the first six months of the present year was the largest ever produced during a similar period, although the increase over the previous record figures is but trifling. Stated in brief the official figures published by Mr. James M. Swank show that the production for the six months ending on the 30th June last, was 7,674,613 tons. As compared with the last half of 1900, when the make was only 6,146,673 tons, this shows an increase of over one and a half million tons. But compared with the first half of 1900, when the output was 7,642,569 tons, the increase is only trifling. That the gain over the corresponding period of last year should be so small may seem strange in view of the fact that the monthly compilations of furnaces in blast, prepared by the Iron Age, have for the last three months indicated that the current output was larger than had ever previously been reached in the country's history. But the explanation is very simple. In 1900 the maximum production (298,014 tons per week) was reached very early—namely February 1—and this high record was pretty well maintained during the first six months, the serious falling off not occurring until the second half; the 1st of April then saw the weekly production somewhat lower, at 289,482 tons, but by the 1st of June the amount was up again to 296,375 tons. The present year, however, the start was from a low total. Last November the output was down to 215,304 tons, and though from that time on the recovery was continuous and very pronounced, yet on the 1st of January of the present year the production was still only 250,351 tons; the 1st of February it was 278,258 tons, and the 1st of March and the 1st of April 292,899 and 296,676 tons, respectively, none of these being up to the maximum for 1900. It was not until May that the 300,000 mark was passed, the output being 301,125 tons, from which there was a further increase to 314,505 tons June 1, but a decline again to 310,950 tons July 1.

JOHN HALLIDAY & SON,

Wholesale and Export Manufacturers

Of Strong and Medium

Men's, Women's & Children's

BOOTS

In Sewn, Screwed, Wood-Pegged,
or Rivetted

WARRANTED
ALL
LEATHER.

BRAMLEY, LEEDS,
ENGLAND.

(Cut will be inserted next week.)

But if the 1901 make of iron for the six months runs but slightly ahead of that for the corresponding period in 1900, the total is nevertheless a very large one. Should the production for the second six months of 1901 be of equal proportions, the aggregate for the twelve months would be over 15 1-3 million tons, while the very largest previous output in a calendar year has been only 13 3/4 million tons.

CONDITIONS ON THE CONTINENT.

It is stated in British banking circles that the commercial outlook in Germany is causing much uneasiness. No serious failures are anticipated. But no one who understands the situation in Germany attempts to deny that the banks generally have locked up too much capital in assisting industrial companies and it is feared that some of the weak provincial banks may have to liquidate. There are numerous failures reported of industrial and trading concerns of all kinds, and a great many more of them are in serious difficulties. Naturally the embarrassed German operators and concerns have been selling everything they could dispose of, both in London and in Paris, and their sales have caused the sharp fall recently. That they will sell more whenever the opportunity offers is not doubted; but for the time being they cannot sell very much, and the fact that they cannot, compels the wealthy capitalists and bankers to restrict the accommodation they give to the industrial companies and so adds to the embarrassments of the latter.

The commercial position in Belgium is nearly as unpromising as that in Germany. But Belgium, from a business standpoint is far more intimately connected with France than with Britain although a very large amount of the acceptances of Belgian banks are held in London. Still, the crisis in Belgium does not affect the nervous state of London as much as that in Germany. In France,

although a good deal of money has been lost in industrial enterprises, everything is perfectly sound. There has been very little speculation and the accumulation of capital in Paris is enormous; but the conditions in Germany, Belgium, Spain and Portugal make France unwilling to engage in any new enterprise. And the economic condition of Russia is exceedingly bad likewise.

THE CANAL QUESTION.

It grows more and more apparent every day that the much-argued over Nicaragua Canal has been finally abandoned by the United States Executive, who alone would be capable of standing the enormous financial strain that its construction would involve. Hence all the bellicose utterances of the newspapers who urged instant war with Britain if the Clayton-Bulwer treaty were not abrogated, and were prepared to fight to the death for the right to fortify a canal not one foot of which is ever likely to be constructed, must be looked upon as a colossal waste of energy. The report of the Canal Commission (although not officially promulgated) is understood to show a marked preference for the Panama over the Nicaraguan route. Among these advantages have been mentioned the good harbours of the eastern and western end of the proposed Panama canal, the shortness of the route and a consequent shortness of time of transit, larger locks, more gentle curvature and no troublesome winds or river currents to be encountered.

Against these favourable features is urged the difficulty of securing control of the canal, which is now in the possession of a French company, whose franchise provides that the main office shall always be located in France. The attitude of President Hutin, of the French company, has never been defined, and he commands the situation. It is understood that he favours some plan by which this

Contractors to the Lords of the Admiralty.

Telegraphic Address: "ROPES, SUNDERLAND."

CRAVEN & SPEEDING BROTHERS,

Hemp Rope Department.

- Manila Rope, Staple Brand.
- " " "Red Star" "
- " " "Blue Star" "
- Sisal Rope.
- New Zealand Rope.
- Tarred Russian Hemp Rope
- Boltrope & Boltrope Cordage

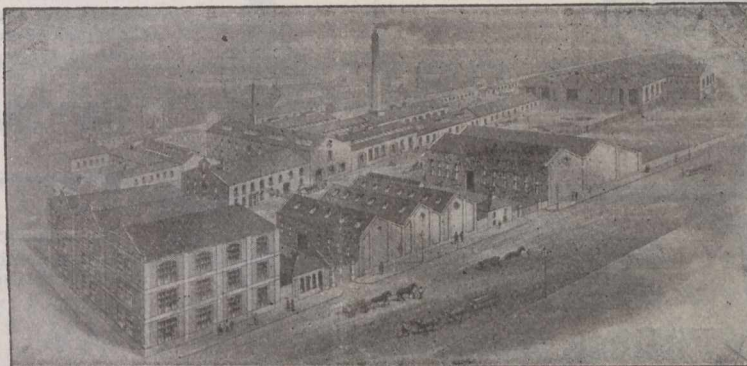

Wire Rope Department.
(COLLERY SECTION.)
Special "C" quality Extra Plough Steel Ropes.
"D" quality Plough Steel Ropes.
Special "A" quality Patent Improved Steel Wire Ropes.
"B" quality Patent Improved Steel Wire Ropes.

Wire Rope Department.
(SHIPPING SECTION.)
Special Flexible Steel Wire Hawsers and Ropes.
Extra Special Flexible Steel Wire Hawsers and Ropes.
B.B. Galvani'd Wire Rigging

AGENCIES : London, Liverpool, Birmingham, Glasgow, Cardiff, Hull.

HEAD OFFICE :

FOREIGN AGENCIES: Hamburg, Antwerp.

Sunderland, England.

SPECIALITY:—Manila Binder Twine "RED STAR" Brand.

canal could be completed under French auspices, leaving him as the general director of the enterprise and associating his name with the work for all time to come. The stock of the company is held largely in France, where it is widely distributed, and this fact has always been urged in Congress as an argument against the possibility of the

American Government gaining control without difficulty and probable international scandal. So far as can be learned, however, there has been in the past few months a pretty decided change of sentiment in Administration circles in favour of this route, and experts are understood to be engaged in a study of the case with a view to devising some plan by which the United States could acquire the right and franchises of the French company, complete and own the canal, with the necessary privilege of guarding it.

Douglas, Lawson & Co.,

ENGINEERS,

Birstall, near Leeds, ENGLAND.

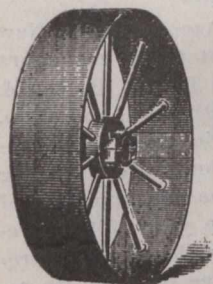

Manufactured under the New Canadian Tariff.

TELEGRAMS :—"Install," Middlesbrough.

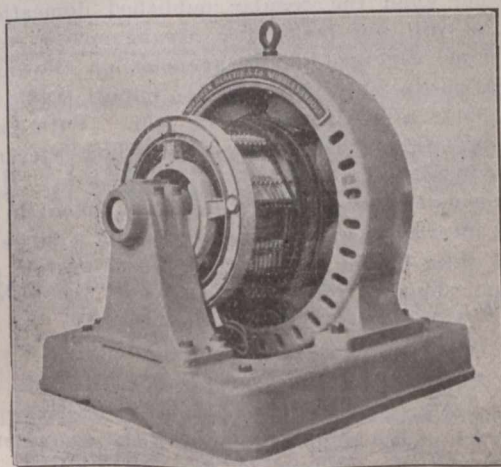

300 KILOWATT DYNAMO.

Warren, Beattie & Co., **ELECTRIC POWER ENGINEERS,**

Contractors for Complete Electric Power and Lighting Installations for Mines, Shipyards, Iron and Steel Works, etc. e.c.

... MIDDLESBROUGH, England.

The unstable politics of the Republic of Colombia would make it necessary that ample concessions be given the United States by which the latter could own sufficient land on either side of the canal to insure its protection. Admiral Walker has suggested that a twelve-mile zone be established across the Isthmus, to be known as "canal territory." This he recommends in case either of the routes is selected, as the conditions of Nicaragua are little more stable than they are in Colombia. Such a great enterprise must not be at the mercy of every band of revolutionists or insurgents that springs up in that land of political unrest.

Another curious drawback to the acceptance of either route is the manifest desire on the part of Great Britain that the United States should undertake the task of cutting an isthmian canal, and the perfect confidence implied thereby that the canal would benefit Britain as much as the United States. In fact some of the opponents of the project use this as an argument against the United States using its credit to back such an enterprise. They claim that the waterway would be as advantageous to Great Britain's shipping interests as it would be to the United States, especially in view of the fact that with the exception of coastwise vessels the United States have a comparatively small merchant marine.

THE GROWTH OF POPULATION.

Most of the nations of the earth, including our own, have taken censuses during the past twelve months, and, although none of them show the increase of 21 per cent. claimed by the United States, which has immigration as well as natural increase to swell its figures, some of them make remarkably good showings. Germany, with 269 people to the square mile, increased 14 per cent.; Holland with 403 to the square mile, and Denmark with 160, increased 13 per cent.; England, with 557, and Norway with only 18, gained 12 per cent.; Belgium with 593, and Hungary with 153, gained 11 per cent., and Switzerland, with 207 to the square mile, gained 10 per cent. Everywhere the growth has been chiefly in the cities, where the best

HOLLOWAY MANUFACTURING COMPANY.

98 Duke Street, GLASGOW, SCOTLAND.

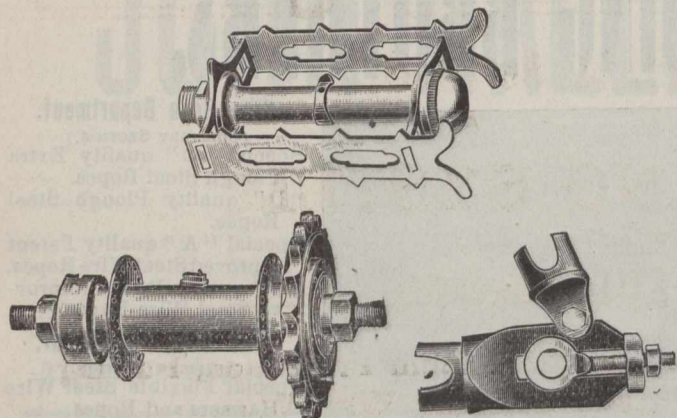

High Grade Cycle Fittings, Motors and General Engineering.

wages can be earned because one may work in a shop every-day in the year, while one is idle much of the time in the country. Besides, machinery being applied to industry more than to agriculture, the product per capita is larger and the workman gets more in the distribution.

THE BEET SUGAR INDUSTRY

The town of Dresden, Ont., is the latest to consider the advisability of bonusing a beet sugar industry, undeterred

„Sloan & Davidson..

Architectural, Sanitary and General

—IRONFOUNDERS—

CARRICK FOUNDRY,

175 Kirkstall Road, - LEEDS, Eng.

4" x 3" Lenses.

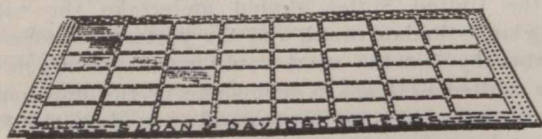

No. 2 Semi-Prism Pavement Lights.

SPECIALITIES.

Rain Water Pipes and Gutters. Railings, Palisadings and Gates, in Cast and Wrought-Iron. Baths, W.C., and Urinal Ranges, for Works and Public Places. Columns and Brackets, Roof Spandrils, Verandahs, Balconies and Band Stands, etc. Spiral and Straight Stairs, Balusters, etc. Pavement Lights. Stall Board Lights.

Light, Plain and Ornamental Castings of all Kinds.

The "SHAW" Patent Improved Valve..

FOR STEAM OR WATER

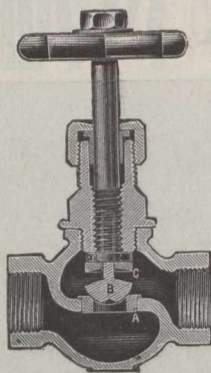

Special advantages: Bronze Metal Renewable Seat, Interchangeable Concentric Valve, Self-Centering under any variation in the wear or strain of the spindle; Special Packing to Valve Spindle. Material and Workmanship of the very best.

The "SHAW" Patent Universal Union Joint

For Coupling pipes at an Angle, is the most Up-to-Date Coupling in the market. Send for full particulars of this and other "Shaw" specialties to . .

JOSEPH SHAW,
HUDDERSFIELD, ENGLAND.

ALBERT WORKS,

Telegrams: "GOVERNOR," Huddersfield.

Supplied under the New Canadian Preferential Tariff.

by the fate of the other beet sugar factories which have absorbed so much of the tax-payers' money. The American promoters, who so far are represented by Capt. James Davidson of Bay City and Messrs. Hurley and Walsh of Detroit, propose, if the bonus of \$40,000 is voted, to build a \$600,000 factory, to have a capacity of 600 tons every 24 hours. At a meeting of ratepayers recently held to discuss the question, Mr. Zagelmeyer, President of the German-American Sugar Company of West Bay City, Michigan, which is this summer erecting a new factory (the fourth in Bay County, Michigan), stated that in four years land values have risen from 25 to 50 per cent. The by-law will be submitted to the ratepayers and a majority of those at the meeting avowed themselves in favour of it.

NO MORE COMMISSIONS.

At a meeting of the Trunk Lines Association in New York at which were present the freight traffic managers of the Grand Trunk Railway, Canadian Pacific, Boston & Maine, Philadelphia and Reading, Baltimore and Ohio, Chesapeake and Ohio, Pennsylvania, Erie, New York Central and Hudson River, and the West Shore, the following resolution was unanimously passed: That the question of import rates, and arrangements for the year 1902, be referred to a committee consisting of at least one representative from each port, that committee to make its report at an adjourned meeting of this general committee to be held not later than September 5. Each company pledges itself that it will not in the meantime quote any rates other than the regular published domestic tariff rates, and will not make any arrangements regarding commissions, cartage, import agencies or allowances of any other character with respect to import traffic leaving foreign ports after December 31, 1901. Both Canadian Pacific and Grand Trunk Railways will be represented on the sub-committee.

This means the opening of a new department in all the railways interested. But it will result in a large saving to them, since it will abolish the present system of paying commissions to import agents.

THE TRANSVAAL FLOUR SEIZURE.

The action of the shipping agents of the American flour, seized by British cruisers off Lorenzo Marquez at the opening of the Boer war, against the owners of the steamships for delay in delivering the flour at destination, revealed some curious facts. It will be remembered that the question raised in all the discussions, including the official correspondence so far as it was made public,

The Roebing Construction Company,

Head Office : Liberty St., New-York.

MANUFACTURERS AND CONTRACTORS FOR

THE ROEBLING SYSTEM

... OF ...

FIRE-PROOFING

Fire-Proof Floors, Ceilings, Partitions, Girder and Column Protection, Furring and Wire Lathing for Ornamental Plaster Effects, Exterior Wall Wire Furring, Etc.

Address all communications to **E. D. HOFELLER, Buffalo, N.Y.**

ALFRED SYKES,

ELECTRICAL
ENGINEER,

Spring Place Works,

Huddersfield,
ENGLAND.

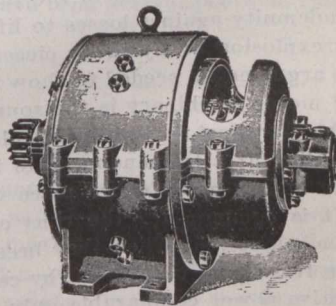

NOTE—Buy British Dynamos, under the New Canadian Preferential Tariff, 33½ in favour of English Goods.

Telegraphic Address: "STANDARD WIRE, SOWERBY BRIDGE."

The STANDARD WIRE COMPANY, Limited,

MANUFACTURERS OF

Patent Plough Steel Rope Wire.
Patent Mild Plough Steel Rope Wire,
Patent Steel Rope Wire,
Galvanised Hawser Wire to Lloyds' Tests.
Galvanised Cable Wire, Bright and Annealed Wire.
Bright and Annealed Core Wire,
Galvanised Mild Steel Rigging Wire,
Soft Steel Screw Wire, Tinned Mattress Wire.

SOWERBY BRIDGE,
ENGLAND.

ALSO AT
DARLINGTON.

was the right of England to interfere with commerce between a United States and a Portuguese port merely upon the suspicion, even though it were a very reasonable suspicion, that the flour was destined for the Boers. The position of Great Britain in making the seizures was further embarrassed by the fact that food not immediately appertaining to the armed forces of a belligerent has never been established as contraband of war.

The question was settled at the time by the purchase of the flour by the British Government for the use of the troops. But in the course of the trial for damages for demurrage the claimants confessed that the flour was destined for Pretoria, the then capital of the extinct Transvaal Republic. And thus instead of being commerce, on its face, between two neutrals, it becomes commerce between one neutral and a belligerent, which must of course be carried on subject to the risk of interference by the other belligerent.

In its decision the Court held that the steamship agents knew that the flour was liable to confiscation, and, therefore delay in its delivery as it was destined for a point situated in a country with which Great Britain was at war, was more than probable. They sought protection in the time-honored proviso in the bill of lading against "restraint by princes, rulers or people," and that as the flour was shipped October 18, 1899, and the Boer ultimatum, though issued October 11, was not published till November, they had no official notice of war. It might be suggested that the shippers had just as much information as the steamship company and its agents; that when they shipped the flour in an English steamer for the use of people with whom they knew England to be at war, whether the full text of the ultimatum had been published in the United States or not, they knew perfectly well what chances they were taking. The decision of the court however, holds the steamship company liable to the shippers.

THE FALL RIVER SYNDICATE.

As a result of the investigations of the committee appointed to look into the affairs of the Fall River Print Cloth Syndicate, that organization has ceased to exist. The termination of the syndicate has been of late looked upon as certain, particularly since the Cornell Mills gave notice of their withdrawal, even though their treasurer was a member of the selling committee and also of the committee appointed to investigate, and its demise cannot be said to have evoked any demonstration in the trade. The feeling has been for quite some time past that the syndicate had ceased to be a useful body, hampering rather than helping the print cloth business.

The selling agreement was established in the fall of

YORKSHIRE RELISH

THE MOST DELICIOUS SAUCE IN THE WORLD
The only Cheap & Good Sauce. Beware of Imitations
Sold in Bottles 6^d, 1/- and 2/- each.

Proprietors, GOODALL, BACKHOUSE & CO., LEEDS.

ENGLAND.

AGENT FOR CANADA

CHAS. GYDE,

20-22 St. Francois-Xavier Street,
MONTREAL.

1898 and became operative only in the last week of October in that year. It first covered only four lines of standards, and, at its outset, worked very satisfactorily. at first in sustaining prices. When the trade became inactive there began quite a general practice of changing slightly from syndicate styles and selling outside the committee's control at prices under the basis of syndicate prices. This practice caused much dissatisfaction and resulted finally in the extension of the provisions of the agreement to cover all plain goods under 33 inches in width woven from print cloth yarns. The manufacturers would not consent to give up individual control of wide goods. For many months now selling committee methods and results have not given general satisfaction. It is not expected that the dissolving of the selling agreement will affect the market. Some months ago the selling committee gave up pegging prices, and since then all bids for syndicate goods, no matter at what prices, were sent along to the treasurers for acceptance, if desired. The manufacturers as a whole, not the committee, have been maintaining prices. Following the meeting a paper was issued containing an agreement to a general reduction of 15 per cent. in wages, to take effect September 3. The paper is being circulated for signatures.

THE CHEMICAL MARKET.

A private Manchester, Eng., circular date July 27th, treating of the chemical situation, says: For almost all kinds of chemicals there is but a limited enquiry at present. Bleaching powder continues dull, without change in price. Caustic soda also has a small enquiry, but values are maintained. Soda crystals and bicarbonate of soda are steady. Chlorates of potash and soda are quiet and rather easier. Exports of bleaching materials and soda compounds show a further decline; during the first half of this year, as compared with the first half of 1900, there is in the former a decrease of 11,799 tons, or £335,159 and in the latter a decrease of 16,758 tons or £83,649. In tar products there is no large business doing. Benzoles remain firm, and there buyers for forward delivery, but the production being small at present makers are not anxious sellers. Solvent naphtha is depressed, and buyers are not taking delivery as freely as usual at this season of the year. Crude carbolic acid is weak, and the moderate business passing is mostly to cover orders taken some time ago. Crystal carbolic is dull, and liquid moves very slowly. Creosote has only a moderate enquiry considering the time of the year, most consumers having arrears to take on their contracts. Pitch remains steady. Sulphate of ammonia is firmer, and buyers are operating more freely for present and forward delivery. In muriate and carbonate of ammonia there is a moderate business doing at steady prices. Acetates of lime and soda

are neglected. Acetates of lead and other lead salts have a fair enquiry for near delivery only. Borax has been reduced further and is offering freely, and present values are tempting consumers. Green copperas is enquired for and is firm. Sulphate of copper is rather firmer, and business is being negotiated for spring delivery. Carbonate and caustic potash are very slow of sale, and values easy, especially for the former. Prussiates continue to drag; there is some enquiry for next year's delivery, but makers are not selling beyond this year. Bichromates are dull, but quotations steady. Arsenic is again rather easier. Tartaric acid is slow of sale, and quoted lower for forward delivery.

FLY-WHEEL INSURANCE.

A new firm of insurance is now in the British market in the shape of indemnity against losses to life and property caused by the explosion or flying to pieces of fly-wheels. In this case no argument is needed to show that if any particular part of motor machinery is the source of an insurable hazard the fly-wheel is that particular part. Fly-wheels are whirling at a tremendous rate in every centre of manufacture and in every other place where power is generated. It is common for the rims of fly-wheels to travel "a mile a minute." When they break, as they frequently do, the fragments thrown off by centrifugal force have a destructive power comparable only with that of a projectile fired from heavy ordnance. Such accidents result in damage to the machinery, destruction of other property, loss of life, bodily injuries, etc. The owner of the wheel is liable for these losses, and the new insurance relieves him of that liability. The Fidelity and Casualty has brought out this interesting new line of underwriting. The new policy covers users of engines against loss when persons are killed or injured by the disruption of engine pulleys and fly-wheels, and also against damage to property, whether that of the insured or of third parties for which the insured is liable.

BAY OF QUINTE NOTES.

Charles Cahoon, near Picton, had his harvest cut and gathered by an auto-harvester, the first to be seen in this vicinity. The problem now confronting the farmer is whether these machines will supplant the farm horse.—W. J. Bowen, late of Strathcona, has opened a grocery in Deseronto.—Owing to numerous small fires which have lately taken place in Deseronto, the Council of that municipality have just passed a by-law prohibiting the use of naked or unprotected lights in stores in that town, and prohibiting combustible or inflammable goods being hung or

Single Plated Built Rudder

**FINISHED COMPLETE
READY FOR SHIPPING**

Manufactured in 8 Days
...By....

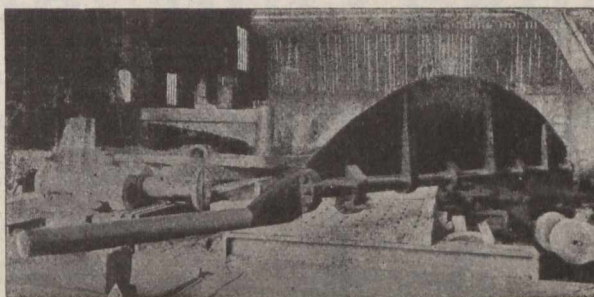

THE

Fownes Forge & Engineering Company, LIMITED.

ST. BEDE WORKS, TYNE DOCK,

South Shields, Eng.

placed close to the lights.—Haying is over and a good crop was secured in this district.—Ferguson Bros., Kingston, formerly in the hardware business in Napanee, have purchased a mica mine located on Campbell's farm, Township of Bedford, and commenced operations last Monday. The mica is known as Muscovite and is valuable.—The Belleville street railway property, electric power house, plant and all, has been advertised as mortgage sale. The street railway seems never to have been a paying concern.—It is rumored in Kingston that the Canadian Pacific Railway intends to take over and manage the Kingston and Pembroke Railway, and to carry on its proposed extensions. There have been several previous rumours to that effect.

DAIRY PRODUCTS.

A private London circular date 26th ult., treating of the dairy situation, says: Butter.—The hot and dry weather which has been destroying the pastures all over the United Kingdom and a great part of the Continent of Europe still continues except in most portions of the United Kingdom where very useful rains have fallen during the last day or two. In Liverpool and district it rained for 36 hours steady while in other parts heavy thunder showers have fallen. It is too early to be certain whether a wet period has set in, but present indications tend rather the other way. The demand for Canadian creameries cannot be called brisk, although there is a fair trade passing. Not until Danish rises some 5s more will Canadian find a good demand. Danish will then be above a shilling retail, and Canadian will make an excellent shilling article. The value of Canadian fancy creameries on the spot to-day is about 96s. These prices are too close to c.i.f. values to encourage any large increase in the importation of Canadian. The drought in America and Canada is reducing the flow of milk, and both butter and cheese are diminishing in make. Cable reports from Australia advise that the season will open late. After thirteen weeks the Copenhagen Official Quotation has been raised two kroner, and now stands at 90 kroner for choicest, and 87 for finest grades, which is two kroner below the corresponding week of last year. The North of England markets this week were rapidly cleared of all strictly choicest grade at last weeks' prices. The secondary qualities were more difficult to move, while Russian and similarly inferior quality was almost unsaleable, and most of it had to be placed in cold store. London is being glutted with Russian butter, of which only a comparatively small quantity goes into consumption, and the cold

stores are being rapidly stocked with it. During the last five weeks the import of all kinds of butter, Russian included, has averaged 4,400 tons per week, or 1,000 tons above the import last year at this time. The price of choicest Russian butter in London is about 78s to 82s per cwt., and the fact that it is not all gobbled up at once at such low prices demonstrates emphatically its inferior quality. Choicest Danish butter is making 104s to 106s.—Cheese.—The demand for Canadian cheese on spot is somewhat better, but not yet brisk, while c.i.f. values have advanced about a shilling per cwt. The make of English cheese, especially in the Southern and Midland counties continues to be small, and unless a very good autumn comes there will be a shortage of fully 15,000 tons. Choicest Canadian is worth 47s to 48s; finest, 44s to 46s. Same week a year ago choicest was quoted at 51s to 52s and finest at 49s to 50s.

RECENT FIRES.

Harriston, Ont., Aug. 1.—Howes & Leighton's saw mill destroyed. Insurance small.—St. Mary's, Ont., 1.—The Garnett House stables destroyed.—Standstead Junction, Que., 2.—Stone sheds, owned by W. Hazelton, destroyed. Loss about \$3,000.—Brantford, Ont., Aug. 4.—The post office at Oshweken, in Tuscarora Township, and the store and home of Chief J. S. Johnson, destroyed. This was the chief post office on the Indian reservation and was a handsome brick building. Supposed to be incendiary. Loss about \$10,000.—The Grand Trunk grain elevator at Chicago was damaged to the extent of \$75,000, on the 3rd instant.—St. John, N.B., 4.—Barns, with hay and farming implements, belonging to David Austin, Doak Settlement, burned. Cause, children playing.

Picton, Ont., 4.—Barn of A. B. Ketchum, Cherry Valley, burned, with crops and implements. No insurance; supposed incendiary.—Brockville, Ont., 5.—Dwelling at Delta owned by O. Brown, and occupied by J. Ralph, suffered \$1,000 damage; partial insurance.—Magog, Que., 6.—House and barns of Spencer Brown, burned, with about 60 tons of hay. Loss about \$2,500; insured in the Northern for \$1,250.

—The Nova Scotia Steel Company has been reorganized with a capital of \$9,500,000, divided as follows: Bonds, \$2,500,000; preferred stock, \$2,000,000, of which \$1,030,000 has been issued and \$5,000,000 of common stock; \$2,090,000, of which had been issued and representing \$1,030,000 of the

Machines in use, 2402

HP. 71,786.

Made from 1½ to 300 HP.

The De Laval Patent Steam Turbines. Turbine Dynamamos. Turbine Pumps & Fans.

Agents for Australasia:
JAMES BARTRAM & SON, Melbourne.

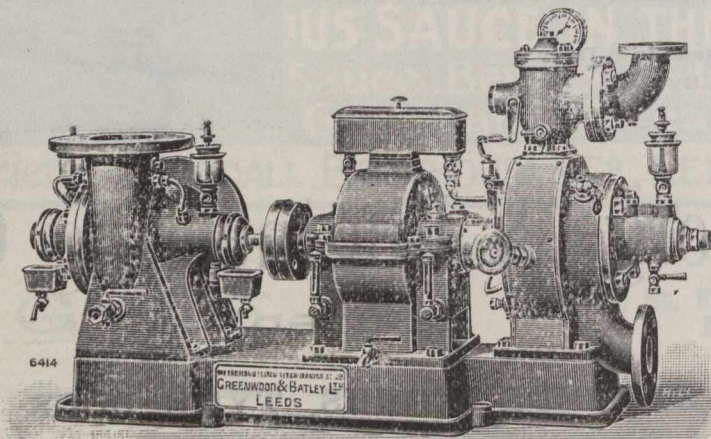

Agents for Egypt:
ALLAN, ALDERSON & CO., Alexandria and Cairo.

No. 6414. DE LAVAL PATENT STEAM TURBINE PUMP,
5 B. H. P. TYPE B. P.

Sole Licensees for Great Britain and all Colonies and Dependencies, China, Japan and Egypt:

THE ENGLISH DE LAVAL STEAM TURBINE CO., Ltd., Leeds, Eng.

SOLE SELLING AGENTS:

Greenwood & Batley, Ltd., ALBION WORKS, LEEDS, Eng.

To whom all Communications should be Addressed.

old company's common stock. Halifax advices state that the issue of 6 per cent. thirty years gold-bonds to the extent of \$2,500,000 will be made, it is said, in October, but meantime the underwriting of the issue has been going on steadily until the statement is now officially made that the whole has been successfully accomplished. It is further stated that the underwriting of the issue in question has not been undertaken by a syndicate of banks. It is understood, however, that banks and corporations have underwritten large blocks individually and that English, Canadian and American capitalists have likewise participated.

—Hartford, Conn., advices state that Judge Shipman of the United States Circuit Court, has granted a preliminary injunction restraining the Consolidated Lake Superior Company from absorbing the Ontario Lake Superior Company. The suit against the Consolidated Company was brought by Alten S. Miller, of New York, a stockholder, who alleged that the capital stock had been increased without his knowledge and that certain directors of the company had formed a plan to sell to it at an exorbitant price the property of the Ontario Company, of which they are the principal stockholders. The Consolidated Company, which was incorporated under the laws of this state recently increased its capital stock from \$20,000,000 to \$117,000,000. It owns and operates extensive mining, timber and other properties near Lake Superior.

—It is reported at Hamilton, Ont., that the Everett syndicate, with Messrs. H. A. Everett of Detroit and W. Caryl Ely of Buffalo, as the chief promoters, has approached the Cataract Power Company, of that city with a view to including it in the scheme of consolidating all the electric railways between Detroit and Toronto and between Hamilton, and the Falls. The probability is,

says a dispatch, that negotiations will soon be begun for the acquirement of the local power company's numerous electric railways, there being an understanding that this will eventually come about.

—A company is stated to be process of formation in Toronto, among the leaders of which are Dr. Pyne, M.P.P., E. L. Sawyer, H. H. Dewart, K.C., C. H. Riggs, G. H. Fensom, G. A. Baker, and A. T. Lawson, for the purpose of investment in apartment houses in that city. They have been incorporated as the Modern Flat Building Company and purpose, it is said, erecting a number of such modern conveniences. The first is to be at the corner of Jarvis street and Wilton avenue, be six stories and have 48 suites, to be available at from \$20 to \$30 a month.

—The Dominion Government analysts endorse the idea propounded by medical men that canned salmon should be stamped with the date on which the fish has been put up and that it should not be kept for sale beyond a certain number of years on the ground that it is liable to deteriorate and become dangerous to health. A bulletin dealing with the matter will be issued by the Inland Revenue Department shortly.

—The officials of the Department of the Interior, Lands branch, Ottawa, are engaged in issuing the patents for the remaining portion of the C.P.R. land grant. By fall it is expected that the whole of the grant for the main line will have been finished, after which the lands earned by the building of branch roads will be allotted; then the selection will be made of lands for the Canadian Northern and other companies.

—A Long Island, N.Y., justice has decided that to send a worthless package by express to a person, requiring the

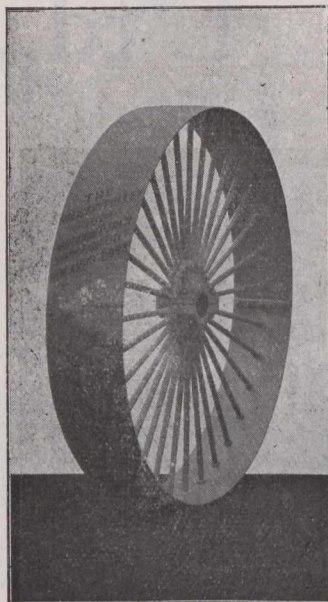

'RODGERS' PULLEYS'

(REGISTERED.)

WROUGHT IRON THROUGHOUT:—RIM, ARMS AND BOSS.

THE ONLY PULLEY MADE WITH A WROUGHT IRON BOSS.

Split or Solid.

All Sizes up to 24 feet Diameter.

140,000 in use.

THE BEST PULLEY IN THE WORLD.

Pamphlets, Drawings and Prices
Forwarded on application.

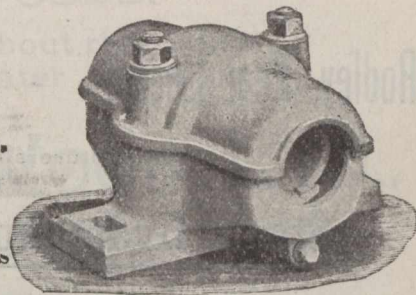

The "NON-DRIP" Shaft Bearing. (ETCHELL'S PATENT.)

Self Swivelling. Self Lubricating. No Drip Cups Required.

SEND FOR PRICES,

SOLE MAKERS:

HUDSWELL, CLARKE & CO., Ltd.,

RAILWAY FOUNDRY.

(Telegraphic Address: "LOCO," Leeds.)

LEEDS, ENGLAND.

recipient to pay charges, comes under the head of petty larceny and is punishable as such. In the case the justice decided one man had sent by express a worthless package to another as a joke. The express charge was 35 cents. The man who got the package couldn't see anything funny in the business and complained to the magistrate, who entered a charge of petty larceny and extortion and fined the joker \$5 and costs.

—Late advices from Costa Rica report considerable public dissatisfaction in that republic with the Government's increase of import duties owing to the abolition of export duties. It is feared that if the Government continues to increase the duties a revolution will follow. Already precautions have been taken to protect the lading Government officials. The new taxes have resulted in a general decrease in wages.

—The Dominion Immigration Department is having a number of show cases made for the agencies in Great Britain. Each will contain a complete collection of Canadian cereals, grasses and soils. The cereals will be shown threshed and on the stalk. A show case will be placed on exhibition at each immigration agency, and will afford to the British farmer a good idea of the agricultural resources of Canada.

—We learn from Sydney, N.S., that Messrs. F. D. Copeland, Antigonish, and A. C. Ross, Sydney, have obtained an act of incorporation under the joint stock companies' act, as the Dominion Powder Co. The object of the company is to engage in the manufacture of gunpowder and other explosives used principally at collieries. Plans have been prepared and the plant purchased. It is expected the plant will be in operation in three months.

—A late London cable announces that the all-British Pacific cable scheme has taken an important step in advance. The Government bill authorizing the sum of £2,000,000 to be spent on the line connecting Vancouver with New Zealand and Australia. The cable will be controlled by a special board, including representatives of Canada, New South Wales, Queensland, Victoria, and New Zealand.

—Halifax, N.S., Notes.—A delegation waited on the Nova Scotia Government recently, and asked that assistance be extended to a steel ship building plant. Delegates from all parts of Nova Scotia favoured the arrange-

ment. Premier Murray in reply, said that the matter had been under consideration for some time and recognizing its importance an early announcement of policy would be made.

Grand Trunk Railway System—Earnings 22nd to 31st July, 1901, \$793,310; 1900, \$700,369; increase, \$92,921.

—The ratepayers of Port Elgin, Ont., recently, by a vote of 195 to 21, voted a loan of \$4,000 to Stevens, Hepner Co., brush manufacturers, for the purpose of erecting additional buildings.

—In the course of a speech at the closing session of the Newfoundland Legislative Assembly last week, the Governor, Sir Cavendish Boyle, announced that the Marconi system of wireless telegraphy would be installed along the Labrador coast at an early date.

LEGAL RECORD.

The following is a record of transactions and cases in our Canadian courts of law, comprising Writs Issued and Judgments Rendered for sums of \$300 and upwards (Montreal, from \$175 and upwards), and Chattel Mortgages and Bills of Sale (for sums of \$550 and upwards), as taken from the public records. It will be understood that the actions or items do not necessarily affect the credit and soundness of the persons or concerns named, as they may have been paid or otherwise settled, and that good defence may exist in case of writs, etc.

WRITS ISSUED—ONTARIO.

Clarkson—S. Price vs R. Quance, \$3,061; Galt—J. M. Hancock vs Jane McQueen, exrx., \$948; Nepean Tp.—T. Linahan vs J. Linahan, \$1,000; Ottawa East—Capital Planing Mill Co. vs M. T. Beaudry, \$363; Ottawa—Capital Planing Mill Co. vs E. Boudriault, \$1,300; Scott Tp.—D. Pugh et al exrs vs J. Paris, \$372; Dorchester N. Tp.—D. MacMillan et al vs J. Durand, \$407; Front of Leeds and Lansdowne Tps.—H. S. McDonald et al vs J. Kidd, \$500; Galt—J. J. Williams vs est of J. McQueen, \$376; Hay Tp.—Clement, Lafleur & Lecair vs J. Cantin, \$751; London—Bank of Toronto vs Mary Schreiber, \$401; Niagara Falls—J. J. Bampfield vs C. E. Smith et al, \$345; Ottawa—G. J. Lavoie vs R. P. Robinson, \$500; Seaforth—T. F. Coleman vs Coleman Salt Co., et al, \$5,586; Toronto—J. A. Morrison vs B. F. & I. R. Alexander, 10,274; McWilliam & Everest vs R. M. Gray, exr., \$855; Ontario Bank vs H. G. Shaver, \$1,506.

Joseph Booth & Bros., L'td.,

ENGINEERS
and **MANUFACTURERS,**
Rodley, Near Leeds, - - England.

Manufacturers of

Steam Hydraulic Cranes
and **Lifting Machinery,**

Under the New Canadian Tariff.

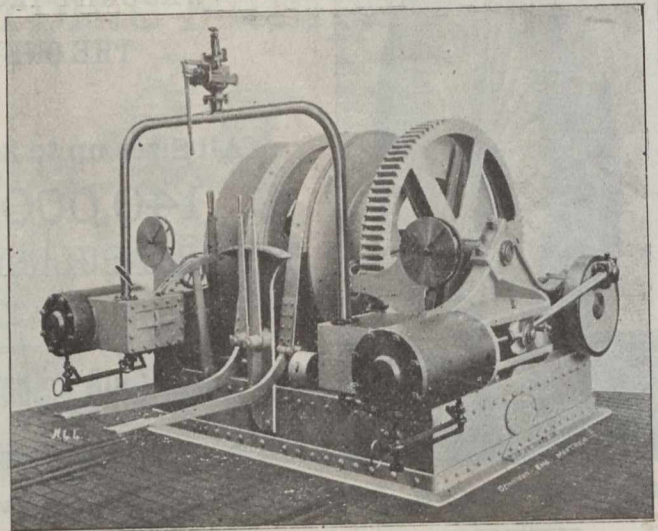

ESTABLISHED 1827.

H. HENDERSON & SONS,

Tanners and Curriers.

Makers of Leather Belting and Fire Hose.

LADYBANK LEATHER WORKS, AND
DUDHOPE & PLEASANCE TANYARDS, DUNDEE, Scotland.

SPECIALTIES

- Oak Bark Tanned Strap Butts.
- Oak Bark Tanned Harness Leather.
- Best Curried Black and Stained Harness and Trace Backs, and all Leathers for Saddlers' Purposes.
- Leather Belting—Single and Double.
- Mechanical Leathers of Every Description, for Foundries, Ship-building Yards, Jute, Cotton, Flax and Woollen Mills.
- Pump Leathers and Hydraulic Rings, etc., etc.
- Walrus Leather in sides from 1/2" to 1 1/2" thick.

JURORS' AWARD INTERNATIONAL EXHIBITION, 1862.
MEDAL & HIGHEST AWARD, Jubilee International Exhibition, ADELAIDE, 1887.
MEDAL & HIGHEST AWARD, Centennial Exhibition, MELBOURNE, 1888.

agt M. Paquette, \$366; St. Romuald, Farnham—Rev. A. C. Larose esql, agt C. Boisvert, \$360.

JUDGMENTS RENDERED—NOVA SCOTIA.

Souris—E. McKenzie, 353; Weymouth—C. Burrill, \$433.

WRITS ISSUED—MANITOBA & N.W.T.

Calgary—Mackenzie & Gillespie, \$466, \$472 and \$1,003;
Elkhorn—J. W. Carwin, \$1,210.

JUDGMENTS RENDERED—ONTARIO.

London—H. Brodrecht agt W. S. Bowden et al, \$415;
Maryboro Tp.—W. Mulock, trustee, agt E. M. Vandusen, \$1,488; Niagara Falls—J. Le R. Smith agt Niagara Metallic Furniture Co., Ltd., \$500; Scott Tp.—J. Crowther agt J. & M. Oliver, \$2,262; Stratford—A. Bauer et al agt B. Howald, \$309; Torbolton Tp.—Georgina Scott agt J. & Sarah E. Murdock, \$589; Toronto—J. F. Pease Furniture Company agt H. W. and Elizth. J. Van Every, \$410; Wroxeter—D. Martin agt S. B. McKelvie et al, \$677;—E. Bourne & Co., agt Niagara Metallic Furniture Co., Ltd., \$575; Toronto—E. T. Wright & Co. agt J. T. Craig, \$365.

JUDGMENTS RENDERED—QUEBEC.

Granby—Birkbeck I. S. & S. Co. agt De. C. Bessette et vir, \$1,375; Grand Mere—Laurentide Pulp Co. agt H. Wise, \$890; Louiseville—Dme. Mathilde Belanger agt A. I. Gravel, \$704; Montreal—Hon. L. F. R. Masson et al esql. agt A. Lemieux, \$15,425; Quebec—Banque de Quebec agt A. Charlebois, \$14,173; St. Angele de Laval—A. Baptist agt C. R. Scott, \$303; St. Anne du Sault—S. Lamothe agt D. Smith, \$300; Shawenegan Falls—Bk. of Ottawa agt I. Girard, \$302; Three Rivers—C. Dion agt C. Dion & Co., \$300; Birkbeck I. & S. & S. Co. agt V. Desmarais, \$2,714.

EXECUTIONS—QUEBEC.

Montreal—Z. Raymond agt D. McPherson, \$371; Telfer & Ruthven Co. agt De. A. Murphy, \$356; Town of St. Louis

G. F. FINISTER, Crown Street, LEEDS, ENG.

Assembly Works,

MANUFACTURER
OF

BEDSTEADS

Folders, Chair-Bedsteads, Wire Spring Mattresses,
and Coppered Diamond Spring Mattresses.

WIRE MESHES FOR MATTRESS MAKERS.

Angle Irons and Dovetails for Wood Bedsteads.

Special terms to Canadians under the New Preferential Tariff.

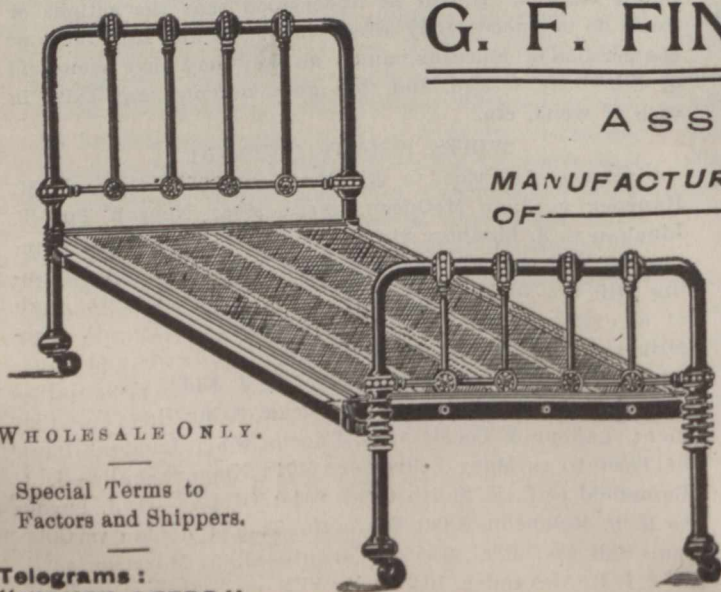

WHOLESALE ONLY.

Special Terms to
Factors and Shippers.

Telegrams:
"WOVEN, LEEDS."

Telegrams:—"Lumby Halifax, Eng."

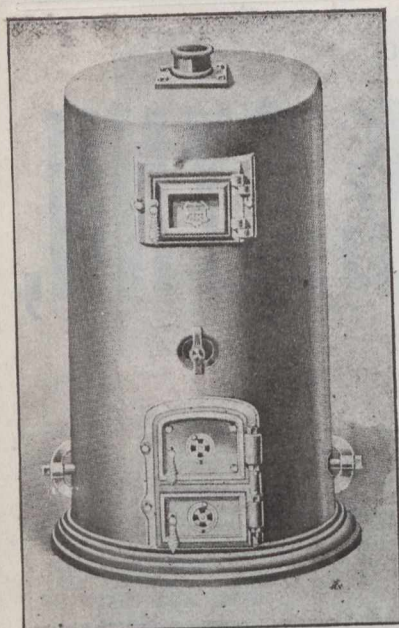

BOILERS.

FOR ALL PURPOSES.

All Wrought WELDED without rivets, and without seams for Hot Water or Steam.

LUMBY, SON & WOOD, LTD.,

HALIFAX, ENGLAND.

Finest Catalogue in the Trade Post Free. Prompt Deliveries. Special terms to Canadian buyers under new Preferential Tariff.

JUDGMENTS RENDERED—P. E. ISLAND.

Cape Traverse—A. Strange, \$2,010 and \$2,010.

JUDGMENTS RENDERED—BRITISH COLUMBIA.

Vancouver—M. Tyson, \$841; White Horse—J. C. Schermerhorn, \$2,337 and \$1,073.

CHATTEL MORTGAGES—ONTARIO.

Brantford—W. J. Barton and wife to J. N. Peel, \$1,061; Oshawa—J. W. Ray to T. H. McMillan, \$2,337; Sault Ste. Marie—O'Boyle Bros. to W. H. Plummer, \$6,773; Stratford—T. Smith to Laidlaw-Watson Shoe Co., \$2,068; Teeswater—W. Habkirk to J. Button, \$830; Whitby—J. H. Nickolson et al to C. J. Johnson, \$3,000; Windsor—J. C. Peters to Walkerville Brew. Co., \$1,700; Wingham—James Broadway to O'Keefe Brew. Co., \$1,300;—Brantford Street Ry. Co. to R. S. Schell, trustee, \$4,203; Aylmer—

C. J. & L. & J. Gundry to A. J. Gundry, \$742; Berlin—A. & Amelia Bossard to Kuntz & Barrie, \$3,012; Hamilton—H. Atwell to J. McPherson Co., \$2,924; D. H. Long to H. Kuntz, \$698; Rat Portage—J. C. Brady et al to G. M. Brady, \$2,360; St. Thomas—A. V. Ellis to C. W. Ellis, \$7,470; Toronto—A. A. Alexander and wife to A. A. Allan, \$836; Hall & Downey to Canada Perm. Corp., \$9,750; Wroxeter—D. Gadke & C. Reis to Bank of Montreal, assignee, \$3,643.

CHATTEL MORTGAGES—BRITISH COLUMBIA.

Greenwood—Cartier & Dale, \$1,350; Nelson—McFarland & Brockman, \$2,225.

CHATTEL MORTGAGES—MANITOBA & N.W.T.

Carberry—W. I. Smale, \$1,400; Morris—F. S. Phillips, \$1,300.

—The boot and shoe firm of Messrs. Hirsh & Sons, St. Thomas, Ont., has been dissolved, the senior member, Mr Samuel Hirsh, retiring. His two sons will continue the business.

Joseph Fisher, clothing merchant, of Quebec, has assigned with liabilities of \$6,000 and assets estimated at \$4,500. Of these \$1,800 is the value of the stock in his Quebec establishment and \$2,700 that of the stock at his branch in St. Francois de Beauce. He is offering to compromise at 40 cents in the dollar spread over twelve months, which is now under consider-

ation. Fisher was previously at Roberval, and also at St. Romuald, but does not appear to have been successful in either place.

FINANCIAL.

Montreal, Thursday, Noon, August 8th, 1901.

The country is busy reaping what promises to be the largest harvest ever grown in Canada. Probably that of Manitoba and the North-West has been exaggerated, but if, as one expert observer who has been over the

Telephone UP 1091.

H. O'BRIEN & CO.,

Real Estate Agents, Interior Painters, Designers and Decorators,

257 B eury St., Montreal,

SOLE AGENTS FOR Electric Sanitary No Dust Floor Dressing
AGENTS FOR English, American and Canadian Wall Paper.
Used by the Leading Merchants.

El Padre Needles

10 Cents.

VARSIITY,

5 Cents.

The Best

~ CIGARS ~

that money, skill, and nearly half a century's experience can produce.

Made and Guaranteed by

S. DAVIS & SONS,
MONTREAL, Que.

BALLANTYNE & COMPANY,

PLUMBING AND HEATING CONTRACTORS

SPECIAL ATTENTION PAID TO ALTERING OLD SYSTEMS OF HEATING.

FACTORY WORK
CAREFULLY AND SATISFACTORILY EXECUTED

159 St. Antoine Street
MONTREAL, Que.

Tel. Main 2462.

Telegrams: "MAGNETO," Bradford.

ROSLING, APPLEBY & FYNN,

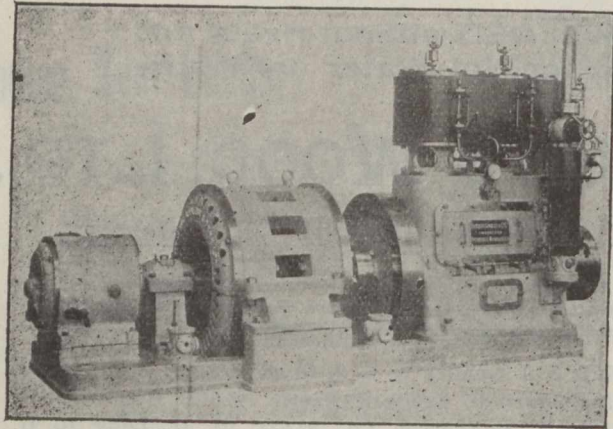

LIMITED.

TRAFALGAR WORKS.

Bradford, Yorkshire, England.

field, declares the yield will not be 60 millions of bushels, but only forty-five to fifty million bushels, that will add enormously to the income of Canada this year, the distribution of the proceeds of which will be felt beneficially in every sphere of trade. The moving of this vast crop to market will strain the C.P.R. to its limit, as it is now doing the physical resources of the North-West in gathering the grain. A financial event of magnitude, as it is also an economic and social one full of possibilities of peril to the trade and the peace of the United States is the great strike of the iron and steel workers. The history of such strikes shows that as they continue there gradually develops a bad feeling amongst the unemployed towards not their employers only but against capital generally, which has often led to very serious attacks on property, with scant regard for the position of its owners. The vast combinations of industries effected in recent years have caused equally large combinations of workmen to be organized and the monetary interests involved enlarge proportionately, so that the entire fabric of business is put in danger by such extensive movements as are now proceeding in the steel and iron trade of the States.

The significance of the great strike may be judged by its having an effect on the London money market, which has been also depressed by the unfavourable crop reports in the States. The Standard Oil Co. declared a dividend of \$8 per share on the 6th instant, which makes 40 per cent. declared this year. Yet the stock fell on this being announced from 772 to 768 as more was expected, which shows what appetites the stockholders must have. Consols after touch-93½ on 31st July, are down to 93 3-16. There will be no advance until the enormous outlays cease in checking the brigands in South Africa. The

Johannesburg mines, however, are to be opened shortly which will add to the gold supply and to some extent ease the situation. A block of 6,560 Heat and Power shares were negotiated on the local 'Change yesterday at 93, the exact meaning of which is not apparent. It was certainly not an investors' purchase and probably no purchase at all, in the business sense, but a transfer under some understanding. Pacific has been ranging from 107½ to 107⅝, there being little disposition to give higher figures, though a few were sold to-day at 108⅓. Outside these stocks there has been no movement. Trifling sales of bank stocks were: Montreal, 256; Bank of Commerce, 155; Merchants, 151½; Hochelaga, 140; Molsons, 204. Grand Trunk and C.P.R. are having heavier receipts than in same week last year. Paris, exchange on London, 25f. 20c.; Berlin, 20m. 45pf. In New York, call money is 2½ per cent., and for good paper, 4½ to 5 per cent. Local foreign exchange, 60's, 9 15-16 to 9 7-16; demand, 9⅞ to 10. Money rates remain unchanged.

The following is a comparative table of stocks for week ending Aug. 8th, supplied by Chas. Meredith & Co., Stock brokers, Montreal:—

Banks.	Shares sold.	Highest.	Lowest.	Average same date 1900.
Montreal	28	255½	255¼	253
Molsons	1	204	204	182
Merchants	70	151½	150	150
Commerce	3	158	155	147
Hochelaga.	28	140	140
Miscellaneous.				
Can. Pac. Ry.	4212	108½	107⅞	87
Montreal St. Ry.	802	288⅞	285	247
Do. new	90	290	288	240
Toronto St.	800	109½	108½	95
Twin City x d	1010	94¾	91⅞	58½
Rich & Ont. Nav.	2325	118	114⅞	99⅞
Com. Cable	50	181	180	163½
Bell Telephone	6	173	173	171½
Montreal Cotton.	5	130	130	134
Do. new	4	122	122
Dom. Cotton	125	73	72	86½

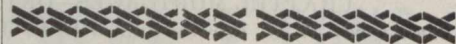

D. M. LONG.

Carpenter

—AND—

Builder,

104 Cathedral St.,
MONTREAL.

Estimates

Given for Buildings of Every Description, including Dwellings, Stores, and Hotel and Bar-room Fixtures.

Tel. Main 3556.

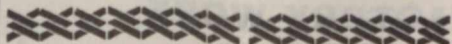

Payne	2500	15	14	93
Dom. Coal, com.	450	39	38
Do. pref.	5115½	115½
Dom. I. & S. com	210	29	28
Do. pref.	40	80¼	80

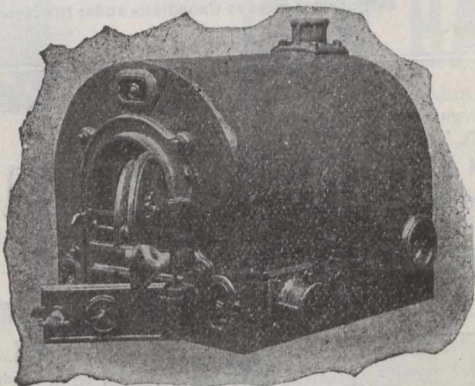
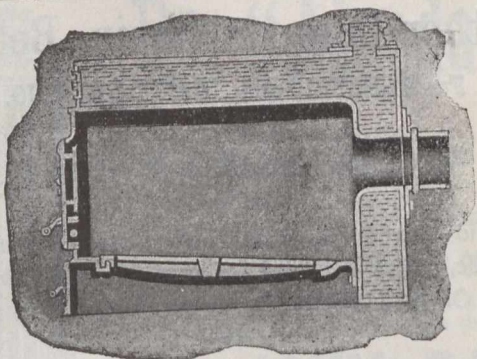

BINNS & SPEIGHT,

Telegrams: **WELDING.** Limited.

WROUGHT IRON WELDED

HEATING BOILERS..

Special prices to
Canadians under
the new Canadian
Tariff.

BRADFORD, ENG.

BRAZILIAN EXCHANGE.

For week ending Aug. 6, 1901.

July 31
Aug. 110	9-16d
210 ³ / ₄ d	
310	25-32d
510 ¹ / ₂ d	
610 ¹ / ₄ d	

MONTREAL WHOLESALE MARKETS.

Thursday, Aug. 8th, 1901.

The week has been productive of few changes in values, owing principally to the midsummer conditions which admit of further life at the holiday resorts and a corresponding quietness in trade centres. The harvest is on and prospects in Ontario and Quebec are assuring for an average yield of cereals. Fruit will be a partial failure. Manitoba and the North-West will have abundant grain crops providing sufficient help can be secured. In trade circles metals are to some extent disturbed by the big strike in the U.S., and already some branches are seriously affected.

BUTTER.—There is a good business passing. The demand keeps well up, export orders arriving freely and pleasing quality in choicest creamery finds quick sale at 20c to 20¹/₂c, with some special makes reaching 21c to 21¹/₄c. There is also a good demand for second grade at 19c to 19¹/₂c, but good lots, held between 19¹/₄c and 20c are slow selling. Trade in dairy butter is more of a local character, the advanced prices being a check on export, this giving the market a somewhat easy tendency. Finest dairy realizes 16³/₄c to 17c, with good solid for baking purposes, 14c to 15c. Receipts are accumulating but are largely of medium qualities which go into stock owing to difference between buyers and sellers as to value. Exports of butter from ports of Montreal and

Portland, for Europe for the week ending August 3rd, 1901:

	Local.	Thro.	Total.
To Liverpool—			
Numidian	2,530	1,080	3,610
To London—			
Fremona		234	234
Total.....	2,530	1,314	3,844
Cor. week last year	34,280	7,670	41,950
Total shipm'ts since			
May 1, 1901.....	124,478	19,576	144,054
Corr. period, 1900..	96,882	18,971	115,853

Shipments via Portland—

	Cheese.	Butter.
To Liverpool—		
Ottoman	2,251	...
Strathnevis	8,497	...
Total.....	10,748	...
Since May 1, 1901.....	82,890	44

CEMENTS, ETC.—No change in prices. Stocks ample for requirements. Recent large orders reported on the market have not yet been reported as given out, trade being confined to small local needs. Arrivals for week ending 6th inst. were: 2,070 brls. Belgian and German cement; 1,250 English cement and 12,673 fire bricks.

CHEESE. — The market is reported much quieter and the feeling is ¹/₄c lower all around. Absence of orders has had a weakening influence and it looks now as though there will be a dull market for the next week or ten days, but the prevailing opinion is that the chances of low prices ruling are remote, the season being too far advanced. Exports of cheese from ports of Montreal and Portland for Europe for the week ending August 3, 1901:

	Local.	Thro.	Total.
To Liverpool—			
Numidian	10,945	1,774	12,719
Lake Ontario	5,758	2,404	9,162
To Glasgow—			
Ontarian	294	1,171	1,465
Tritonia	2,422	1,291	3,713
To London—			
Fremona	22,920	785	23,705
To Leith—			
Leander	2,339	2,651	4,990
To Belfast—			
Torr Head	1,549	100	1,649
To Bristol—			
Lycia	10,249	240	10,489
Total.....	56,476	11,416	67,892
Cor. week last year	69,328	15,208	84,536

At Woodstock, Ont., on the 7th inst., 17 factories boarded 3,790 boxes. Bidding was only fair, beginning at 9¹/₄c, and reaching 9¹/₂c. Only one sale was made of 108 boxes at 9¹/₂c. Orms-town, Que., 7.—1,045 cheese and 70 packages of butter offered; 9³/₈c was paid for 180 boxes of cheese; and 19³/₄c for 45 boxes of butter. Balance unsold. — Napanee, Ont., 7.—901 white and 310 colored cheese boarded; 9¹/₂c bid, no sales.—Picton, Ont., 7.—15 factories boarded 1,107 colored and 275 white. Highest bid, 9¹/₂c; 533 boxes sold. — Stirling, Ont., 7.—910 white boarded. Sales: 845 at 9³/₈c.—Peterboro, Ont., 7.—39 factories boarded, 5,319 boxes second half July make, all colored; bidding brisk. Most sold at 9³/₄c.

DRY GOODS.—Prospects are steadily brightening as the month wears on. Orders are being placed freely for the coming fall trade and the practical certainty of a very large wheat crop in the North-West has given confidence to the trade. Prices are firm. Any change in values is far more likely to be in an upward than a downward direction, and, as a consequence retail houses are more ready to buy since goods taken now are likely to be worth more before long. The paper on the 4th was very satisfactorily met as a rule. Very few renewals are noted, and those that were asked for were only for short dates and accompanied with a liberal instalment on account. In the United States buyers are purchasing specialties for spring with a fair amount of freedom, but they still regard the market for staples and for purely fall goods with more or less indifference. The fact that they are not always able to fill their current requirements without difficulty does not seem to alarm them. Sellers, on the other hand, are not disturbed by the continued quietude, as there is not any important direction pressure evi-

ESTABLISHED 1857.

John Oldfield & Co.,

THE CITY TANNERY
LEATHER WORKS,

BRADFORD, - - England.

OAK TANNED LEATHER BELTING

Single and Double.

(Cut will be inserted next week.)

Leather-Link or Chain Belting.

For ELECTRIC and HEAVY DRIVING.

Picking Straps, Bark Tanned, Green, Buffalo Hide & Helvetia.

Solid Woven Hair and Linen Belting. Buffalo Hide, Skeps or Tubs. LACES—White, Brown, (or Oiled,) Helvetia, Horny and Rop.

Special rates to Canadians under the New Tariff.

dent to stimulate buyers into greater exertions at the expense of values. Some odds and ends of fall specialties may show irregularity, but they are not of a character to affect the general tone. Sellers have also withstood in good shape the recent course of the cotton market, which has certainly not been in their favour. The woollen goods division has furnished the best business of the week, good progress being made in the sales of men's wear light weights for spring, and the market closes with a steady tone.

Eggs.—As usual at this season, the market is showing considerable strength with every possibility of an early advance. Finest new laid command a good export sale at 13c to 13½c, with ordinary run of candled quality at 11½c to 12c. No. 2, 10c to 11c. There is a satisfactory business passing and the demand appears to be increasing every day, so receipts do not accumulate.

FLOUR & FEED.—The week has developed no change in the situation, both flour and feed being in good local demand. The latter is particularly sought, the raise of \$1 per ton last week having no apparent effect. With high prices for pork and dairy products, a good demand is expected to be kept up. Prices on another page.

THE Hunslet Engine Company, LEEDS, Eng.

Telegrams: "ENGINE, LEEDS."

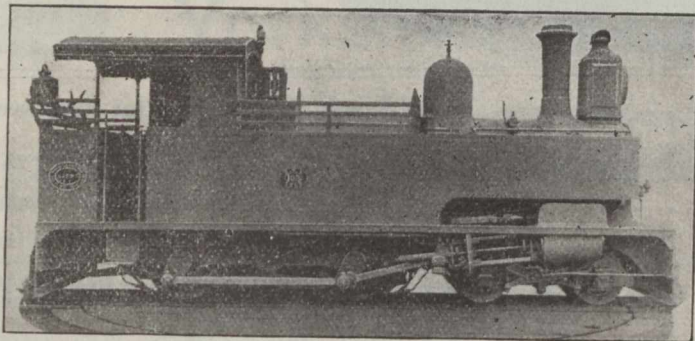

Locomotive Tank Engines

of all descriptions and any size, for

Ironworks, Collieries, Contractors, Docks, Manufactories, Branch Railways, &c., &c.

Specially designed for any circumstances, or to suit any Gauge of Railway.

Arrangements Made for Hire.

On Purchasing Lease or otherwise.

Special prices to Canadians under the New Canadian Tariff.

GREEN FRUITS.—There is already shown on the street sufficient evidence of a short fruit crop to warrant speculation in future apples, pears, etc., at prices which bespeak high values for the approaching season. New apples are small, defective and dear, being dealt in at 35c to 50c per small basket. Estimates refer to a yield of one-third last year's crop for apples, peaches and pears. Cherries are very scarce

and difficult to procure, the crop being virtually a failure. Lemons are in light supply, new fruit being sold at \$4 to \$4.50 per box. Quotations are: Canadian apples, 35c to 50c per basket; Messina oranges, boxes, \$4 to \$5; Cal. late Valencias, \$7 to \$7.50; lemons, 300s, \$4 to \$4.50; bananas, 8-hands, \$1.30 to \$1.50; No. 1, \$1.60 to \$1.90; extras, \$2; pineapples, each 8c to 15c; limes, per 100, \$1.50; new figs,

SUTCLIFFE BROS., Wood Working Machine Makers, Causeway, Halifax, Yorks, Eng.,

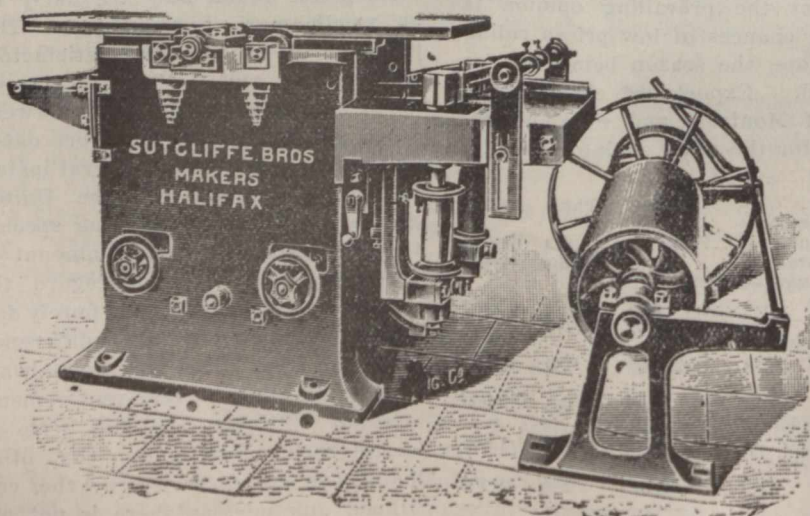

Combined 3-Sided and Planing out of Twist Machine.

This is the most useful machine that a Joiner or Builder can have. It will plane wood perfectly true on the top tables, or will rabbet, bevel, chamfer, or stop chamfer, or plane a perfect glue joint, and on the bottom table will plane wood, self-feeding underneath the cutters, any thickness from 1-16 in. to 8 in. on all three sides at once or separately; or will work nearly every kind of moulding, or tongue and groove boards, to the full width of the machine. It is specially adapted for **DOORS** or any other work which requires planing accurately; one face of the wood is planed true on the top tables, then placed face downwards on the bottom table, and planed on the other three sides, absolutely true and square. The rate of feed can be altered from 10, 17 to 24 feet per minute, and a cut 3/8 in. deep may be taken off without any slipping of the feed motion. The horizontal spindle is all in one piece of forged steel, and runs in long bearings of the best anti-friction metal. It is fitted with **THREE KNIVES** fixed on the twist to give a shearing cut. The upright spindles are of forged steel, and are adjustable across the width of the machine. Countershaft included with machine, and knives on all spindles ready for work. This machine will do more work per hour, and better work, than 20 good men.

Special prices to Canadians under the new Tariff.

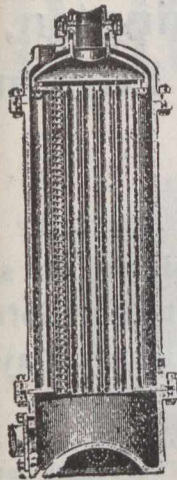

The "Airedale" Exhaust Steam Pressure Feed Water Heater.

Special prices to Canadians under the New Tariff. . .

Green's Patent.

WITH SPIRAL DEFLECTORS.

THE MOST EFFICIENT HEATER ON THE MARKET.

WILL PAY FOR ITSELF IN TWELVE MONTHS.

By means of the SPIRAL DEFLECTORS, as fitted to this Heater, the efficiency of the apparatus is doubled, as compared with a similar Heater without Deflectors.

JOHN BARRETT, Eastburn Foundry **Crosshills,**
KEIGHLEY, England.

Telegrams: "BARRETT," Crosshills.
Engineering Telegraph Code.

mats, 3½c per lb.; do. boxes, 8c to 12c per lb.; new dates, 4c per lb.; nuts, Pecans, extra large, 14c; do. large, 13½c; walnuts, 12c; filberts, 12c; French chestnuts, 10c per lb.; cocoanuts, \$3.25; California plums, \$1.75 to \$2.50 per box; do. peaches, \$1.15 to \$1.25 box; do. pears, Bartletts, \$2.50 to \$2.75 box; onions, \$3 per crate; Egyptian onions, 2c lb.; Canadian, brls., \$2.50; gooseberries, 40c to 50c basket; raspberries, 11c to 12c per box; red currants, 12-qt. basket, 40c to 45c; Canadian peaches, 40c to 60c per basket; California Mal. grapes, \$2.85 to \$3.15 per crate.

GREEN HIDES.—The market showed considerably more business during the past week. No change in prices, however. Cattle are so dear that dealers are not looking for much business. The New York market was reported dull, with prices inclined to sag, as receipts were accumulating without response from tanners. Chicago reported a dull market with buyers doing very little.

GROCERIES.—Wholesale houses were notified this week by the syndicate that prices of canned goods will be advanced on the 15th instant. The amount is not stated. The reasons for this are a reported short crop of peas, corn small and being considera-

bly later than usual fears of frost are entertained. Tomatoes have a good appearance but are not ripening as freely as desired. Peaches, pears and apples are expected to be but a 30 per cent. crop, as compared with last year. Molasses, rice, sugars, coffee, tea, spices, etc., are unchanged. Stocks of currants held throughout Gt. Britain are light, and while business may only be done in a small way it is figured that the limited stocks may be cleared before the arrival of new fruit. London is taking the bulk of the business owing to the limited stocks held in Liverpool — reported at 212 tons, as against 1,036 tons at the same time last year. No particular news has been received, as to the new crop, and it is therefore presumed that everything continues favorable. The cutting of the fruit is now general, and if no rains occur a crop of fine quality will be housed. Best authorities continue to estimate the crop at 140,000 tons, and speak of the retention as practically sure to be fixed at fifteen per cent. A late London letter states that the trade are fully alive to the fact that the crops of both currants and Valencia raisins this year give promise of great abundance. Wholesale dealers are therefore operating with caution, with the result that merchants are not refusing any reasonable offers. Cur-

rants must again be quoted lower for all medium descriptions, the cheapest sales of the week having been of good old at 25s; fine Vostizza, 28s 6d to 29s, and choice at 31s to 32s. Valencia raisins also are being sold on very easy terms, fine selected quarter-boxes only realizing 30s. Sultana show but little variation in values, the gloomy prospects of the new crop giving confidence to holders. Both the Columbia River Packers' Association and the Alaska Packers' Association have reduced prices on salmon, the former's opening prices were \$1.65 for talls, \$1.80 for flats and 75c for halves. The reduction is 10c on the first two named. A Chicago dispatch reads:—"The Alaska Packers' Association named prices on first allotment of Anacortes Packing Co.'s sockeye salmon on the basis of \$1 for talls, \$1.15 for flats, and 85c for halves. Expect further allotment at same prices within a few days. Run continues good and it is expected this will be the record-breaking pack of sockeye salmon.

IRON & HARDWARE.—The presence of American buyers in the market has again sent up prices. Tin plates are growing scarce, and we quote \$4.50 for I.C. coke and \$4.75 for I.C. charcoal with but little to be got at that figure. Stocks are light in every branch of the metal trade, and the demand is

Brick Making and Pressing Machine,
with Toggle Lever Power Press combined.

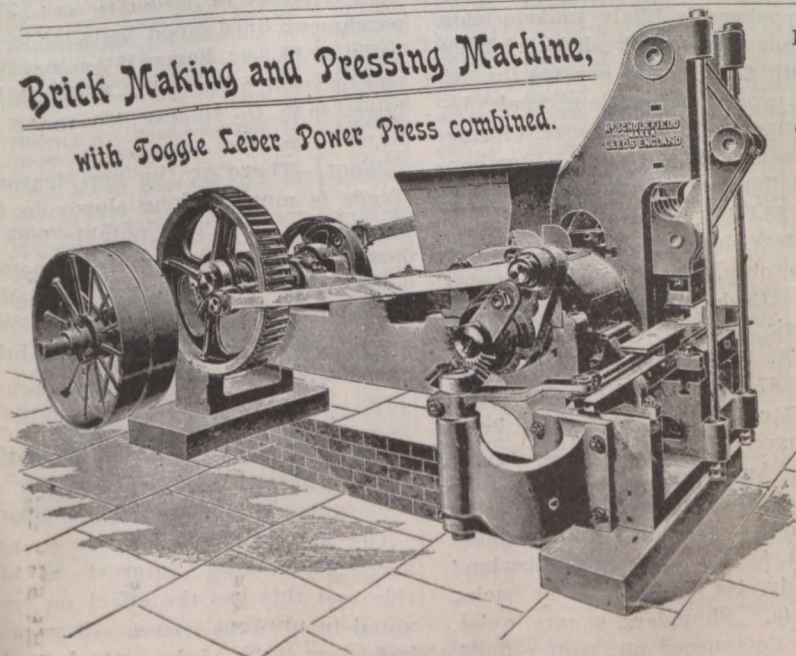

Established 1868.

Telegraphic Address: "Brick, Leeds."

Brick-making & Grinding Machinery

Manufactured
by

Richard Scholefield,

ENGINEER

Burley Vale Mills

Kirkstall Road, LEEDS, Eng.

Johnson & Tucker,

Wilmington,
Hull, England.

(Late SHEPHERD, HILL & Co.,

Pugmill
with
Patent Polygon
Mouthpiece.

For Preventing Lamination
in the Clay.

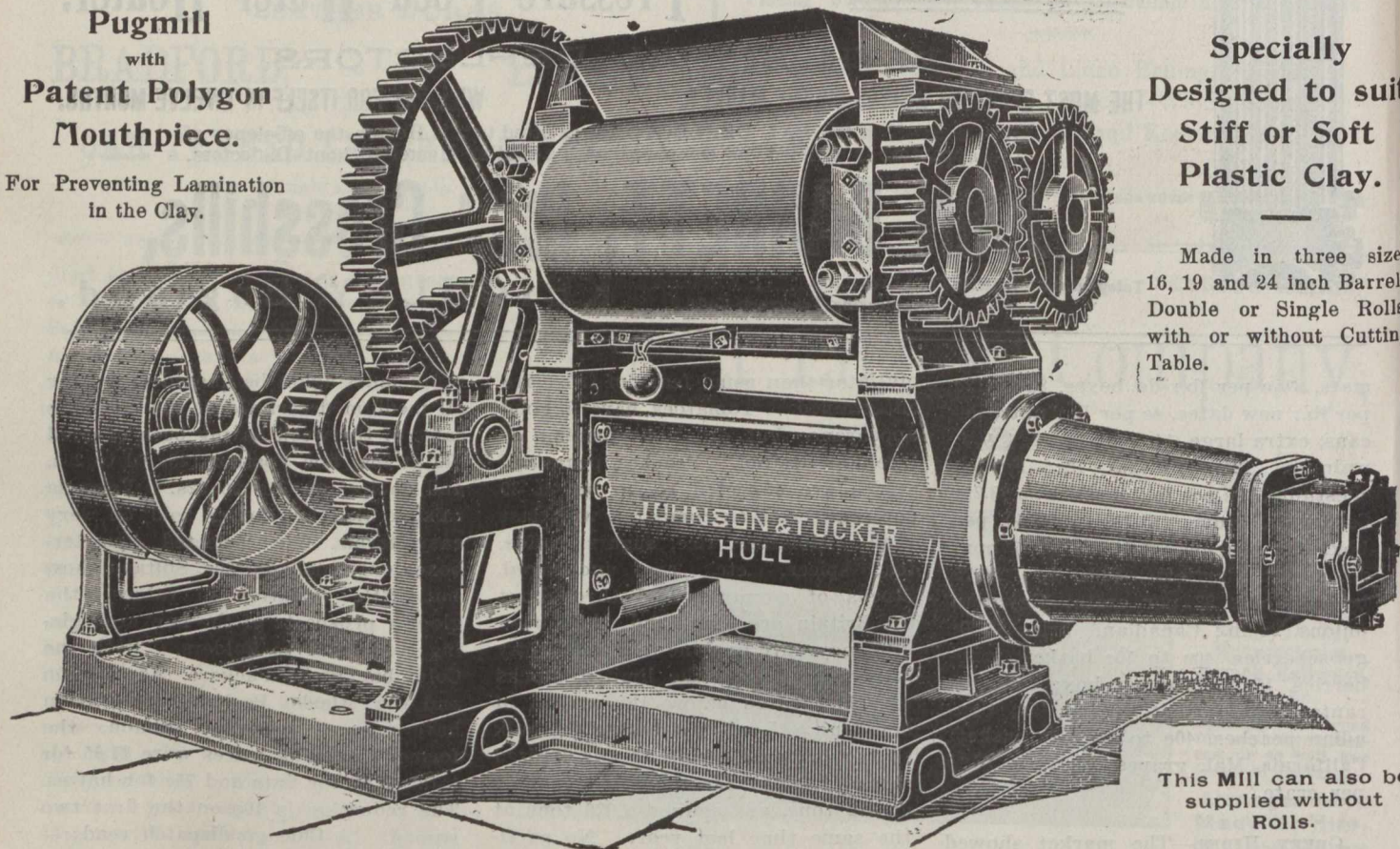

Specially
Designed to suit
Stiff or Soft
Plastic Clay.

Made in three sizes
16, 19 and 24 inch Barrels
Double or Single Rolls
with or without Cutting
Table.

This Mill can also be
supplied without
Rolls.

active in consequence. The coming strike bids fair to stop production sufficiently long to swallow up all the existing stocks, and hardware dealers are looking out to fill requirements before the squeeze comes. The trend of all prices is upward and wholesalers are very firm in their views, in face of the rising prices cabled from England where tin and black sheets are being eagerly taken for the American market. From Pittsburg there come reports by mail of a steadily increasing volume of tonnage in iron and steel and an exceedingly strong tone to the market, with abnormal prices paid for sheets, tin plate and skelp. All the surplus Bessemer and basic iron for August delivery in Pittsburg is said to have been taken up by recent purchases of the United States Steel Corporation, and this has materially strengthened the pig iron situation there. A better tone to the foundry iron market at Pittsburg was reported as a result of improved demand. Bessemer steel billets on the other hand, were reported to be dull and weaker, being now procurable at \$23.50 at the mill for prompt shipment.

LEATHER & SHOES.—The local movement in leather is somewhat disappointing. Export trade, however, continues at a satisfactory pace and prevents accumulation of stocks. There is a shortage at present in desirable plump jobbing leather; in fact, stocks of sole leather are light

all round, but manufacturers' selections are more plentiful. Prices hold firm at the recent advance. The New York market was reported well sold up, both jobbers and manufacturers placing new orders and calling for deliveries. Prices firm.

OILS, PAINTS, ETC.—Seal oils are slightly easier. Turpentine and linseed oils are unchanged. Chemicals are quiet as usual in midsummer.

PROVISIONS.—Prices are unchanged under a steady movement. At interior points high prices for hogs continue to rule and active competition among packers is likely to keep this up for some time. Fresh killed hogs are worth \$9.50 to \$10 per 100 lbs. At Chicago provisions continue weak, declining $2\frac{1}{2}c$ to $5c$ to 15 cents. Closing prices were: Mess pork, September, \$13.82 $\frac{1}{2}$; January, \$14.82 $\frac{1}{2}$; lard, September, \$8.57 $\frac{1}{2}$; October, \$8.65; January, \$8.62 $\frac{1}{2}$; short ribs, September, \$7.77 $\frac{1}{2}$; October, \$7.85; and January, \$7.67 $\frac{1}{2}$. Cash quotations were: — Mess pork, \$13.75 to \$13.80; lard, \$8.55 to \$8.57 $\frac{1}{2}$. Short ribs, sides, loose, \$7.70 to \$7.90; dry salted shoulders, boxed, $7\frac{1}{4}c$ to $7\frac{1}{2}c$, and short clear sides, boxed, \$8.25 to \$8.35. Liverpool, 7.—Lard, American refined, in pails, steady, 43s 6d; prime western, in tierces, quiet, 43s 9d. Hams, short cut, quiet, 53s 6d. Bacon, Cumberland cut, steady, 44s 6d. Short clear backs, steady, 44s. Shoulders, square, quiet, 38s 3d. Cottonseed oil, Hull refined,

spot steady, 23s 6d. Tallow, Australian, in London, firm, 27s 3d. Local quotations: Brls. heavy Canada short cut mess pork, \$21; tierces heavy Canada short cut mess pork, \$31; half barrels do., \$10.75; bbls. selected heavy Canada short cut mess pork, boneless, special quality, \$22; bbls. heavy Canada mess pork, long cut, \$21; bbls. heavy Canada short cut clear pork, \$20.50; half-barrels do., \$10.50; pure Canadian lard, in 375-lb. tierces, 11 $\frac{1}{2}c$; parchment lined 50-lb. boxes, 11 $\frac{3}{4}c$; parchment lined pails, 20-lbs., 12c; tin pails, 11 $\frac{3}{4}c$; tins, 3, 5 and 10 lbs., 12c to 12 $\frac{1}{4}c$; compound refined lard, in 575-lb. tierces, 7 $\frac{3}{4}c$; parchment lined wood pails, 8 $\frac{3}{4}c$; tin pails, 20-lb., 8c; hams, 13 $\frac{1}{2}c$ to 14 $\frac{1}{2}c$; and bacon, 14c to 15c lb. Fresh killed hogs, \$9.50 to \$10 per 100 lbs.

WOOL.—There are no new features. Trade is moving along slowly in fine wools but there is a notable lack of large orders. The tone of the market is inclined to firmness. Canadian wools are being shaded to still lower quotations, yet this does not bring the desired movement.

TORONTO WHOLESALE TRADE.

(Revised by Telegraph.)

Thursday, Aug. 8, 1901.

The attractiveness of the country keeps the holiday interest at high tide and this has the effect on trade noted in previous issues. Dry goods importers speak of the outlook for fall

Bottle Washing Machinery

OUR NEW PATTERN "KINGSTON."

No. 2

22-dozen Half-pint Beers.

Fitted with Revolving Rinsers as shewn,

£27

with Bottle Sinker.

OVER 1,000 'KINGSTONS' are now in use.

Machines from £10 to £40.

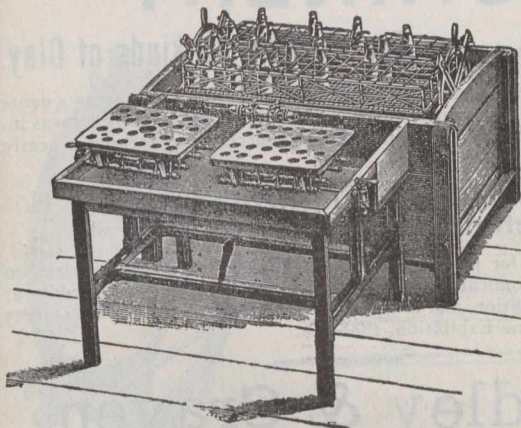

Original Inventor and Patentee.

D. G. BINNINGTON, Kingston Machine Works, HULL, ENGLAND.

Special estimates to Canadians under the New Tariff.

STOCKS AND BONDS.

NAME.	Par Val's.	Capital Subscribed.	Capital paid-up.	Rest.	Div. last 6 Ms	Dates of Dividends.	Per Cent. Price Aug 8 (Bid)	Cash value per S.
British North Am.	243	4,866,666	4,866,666	1,703,333	3	Apl. Oct	122½	29767½
Can. Bank of Commerce	50	8,000,000	8,000,000	2,000,000	3½	June Dec	147	78 50
Commercial, Windsor..	40	500,000	350,000	60,000	3	105	42 00
Dominion	50	2,500,000	2,500,000	2,500,000	2½	May	244	122 00
Eastern Townships.....	50	2,000,000	1,742,535	1,050,000	3½	Jan	150	75 00
Haltfax Banking Co.....	20	600,000	600,000	475,000	3½	Feb. Aug	158	79 00
Hamilton	100	2,000,000	1,995,750	1,500,000	5	June Dec	204½	204 50
Hochelaga	100	1,500,000	1,500,000	750,000	3½	June Dec	152	152 00
Imperial	100	2,500,000	2,500,000	1,850,000	5	June Dec	229	229 00
Merchants' Can.	100	6,000,000	6,000,000	2,600,000	3½	June Dec	150½	150 87
Moisons	50	2,500,000	2,500,000	2,050,000	4	Oct April	205	100 50
Montreal.	200	12,000,000	12,000,000	7,000,000	5	June Dec	255	508 00
Nationale	30	1,200,000	1,200,000	275,000	3	May Nov	95	28 50
New Brunswick.....	100	500,000	500,000	700,000	6	Jan July	300	300 00
Nova Scotia.....	100	2,000,000	2,000,000	2,582,840	4½	Feb. Aug.	232	232 00
Ontario.....	100	1,395,300	1,872,914	350,000	4½	June Dec	122½	122 50
Ottawa.....	100	1,994,900	1,993,380	1,860,747	4 & 1	June Dec	205	205 00
People's of N. B.....	150	180,000	180,000	155,000	4	250	375 00
Provincial.....	25	875,487	781,248	3	June Dec	155	155 00
Quebec.....	100	2,500,000	2,500,000	700,000	3	June Dec	122	122 00
Royal.....	100	2,000,000	2,000,000	1,700,000	3½	Feb Aug	175	175 00
St. Stephen's.....	100	200,000	200,000	45,000	2½	April Oct
Standard	50	1,000,000	1,000,000	750,000	5	April Oct	232	116 00
Toronto	100	2,000,000	2,000,000	2,000,000	5	June Dec	240	240 00
Traders	100	1,350,100	1,344,420	250,000	3	June Dec	112½	112 25
Union (Halifax).....	50	800,000	900,000	505,606	3½	Mch Sept	150	75 00
Union of Canada	100	2,000,000	2,000,000	550,000	3	June Dec
Western.....	100	500,000	401,239	134,000	3½	Apl Oct
Agri. Sav. and Loan Co	50	630,200	630,200	192,000	3	Jan July
Bell Telephone Co	100	5,000,000	5,000,000	800,000	4½	Jan *	172½	170 00
Brit. Can. Loan & Inv. Co.....	100	1,987,900	398,481	120,000	2½	Jan July	128	128 00
Brit. Mortg. Loan Co.....	100	450,000	389,214	120,000	3	Jan July	62	63 00
Can. Colored Cot. Mills Co.....	100	2,700,000	2,700,000	Jan July	90	90 00
Can. Landed & Nat'l Inv't Co.....	100	2,008,000	1,004,000	350,000	3	Jan July	115	57 50
Can. Per. & W. Can. M. Corpn.	10	5,951,350	5,951,350	1,490,857	3	Jan July	114	57 00
Can. Sav. & Loan Co.....	50 & 7½	750,000	750,000	250,000	3½	Jan July	136	136 00
Central Can. Loan & Sav. Co	100	2,500,000	1,250,000	450,000	1½	July Dec	72	86 00
Dominion Sav. and Inv. Co.	50	1,000,000	934,200	30,000	2
Dominion Telegraph Co	50	1,000,000	1,000,000	1½	Jan *	124	62 00
Dominion Cotton Mills Co.....	100	3,333,600	3,333,600	356,752	3	Mar *	77½	77 50
Hamilton Prov. and Loan.....	100	1,500,000	1,100,000	3	Jan July	112	112 00
Home Sav. and Loan Co	10	2,000,000	200,000	200,000	3½	Jan July	135	135 00
Huron & Erie Loan & Sav. Co	50	3,000,000	1,400,000	890,000	4	Jan July	70	89 50
Imperial Loan and Inv. Co.....	100	732,724	730,647	175,000	3	Jan July	111	70 00
Landed Banking and Loan	100	700,000	700,000	210,000	3	Jan July	68	111 00
Land. & Can. Loan and Ag.	50	1,000,000	877,267	87,500	3	Jan July	110	34 00
London Loan Co.....	50	679,700	678,550	160,000	3	Jan July	55	50 00
Manitoba & North-W. Ln Co	100	1,500,000	375,000	50,000	Jan	170	55 00
Montreal Telegraph Co.....	40	2,000,000	2,000,000	2	Jan	170	68 00
Montreal Gas Co	40	3,000,000	2,998,640	5	April Oct	241½	96 50
Montreal Street Ry. Co.....	50	5,000,000	4,500,000	560,318	2½	Feb. *	258½	145 87
Montreal Cotton Co.....	100	1,400,000	1,400,000	600,000	4	Mch. *	130	129 00
Montreal Loan and Inv. Co.....	100	1,250,000	1,250,000	3½ & 1	Feb Aug	111	111 00
Merchants Cot. Co.....	25	500,000	500,000	360,000	3	Mch Sep	187½	34 87
Montreal Loan and Mortg.....	100	466,800	314,386	150,000	3	Jan July	121½	60 75
Ont. Indus. Loan and Inv. Co.	50	2,000,000	1,200,000	535,000	3	Jan July	24	12 00
Ont. Loan and Deb. Co.....	50	600,000	600,000	3	Jan July	70	35 00
People's Loan and Dep. Co.	40	373,720	373,720	50,000	2	Jan Nov	115	118 50
Real Est. Loan Co.....	100	2,088,000	2,088,000	162,355	3	May	240½	240 50
Richelieu and Ont. Nav. Co.	100	2,250,000	2,250,000	320,155	Jan. *	136	136 00
The Royal Electric Co	100	2,000,000	2,000,000	Jan. *	78½	76 50
Toronto Electric Light Co.....	50	1,445,860	724,540	250,000	2½	108	108 00
Toronto Mortgage Co.....	100	6,000,000	6,000,000	Jan. *	112½	112 50
Toronto Street Railway.....	100	6,000,000	6,000,000
Windsor Hotel	100

* Paying quarterly dividends.

and winter trade as promising beyond that of recent years. The return to plain weaves in suitings permits retailers going deeper in without fear of overstocking, for the plain fabrics are to a large degree always staple. A good deal of faith is being placed in the demand for heavier class fabrics, which has sprung up lately, and manufacturers especially seem to have adopted it as a good sign. Whether the request will expand must be yet seen, but many regard it as a development which is likely to characterize the season. The opinion of those who believed the lighter drapery fabrics would be worn extensively this fall does not seem to count for much at present, and preparations are being made to adopt the product of the looms to the demand. Goods on the Venetian and broadcloth order, chevots with smooth finish and similar fabrics are to be included in this demand, which has arisen more especially from the manufacturing trade. For skirts these fabrics are regarded as admirably adapted, and it is believed by some that there may be before long a scarcity of this class of goods. A fair business continues on pebble chevots. A good business is also looked for on vigoreaux effects in the better grades, while coverts are fully living up to the demand looked for. Light weight broadcloths are also in considerable demand for fancy waists, and have been chosen by the exclusive trade who look for touch, finish, freshness of color and draping qualities in a material for this purpose. In fancies, as far as can be seen from orders already placed, one of the leading novelties will be canvas or hopsack weaves, while fancy waistings in stripes, corded effects in solid colors, lustrous materials with fancy borders and tucked effects, etc., have been well represented in orders placed.

Butter.—Demand better, owing to cooler weather. Prices firm at old

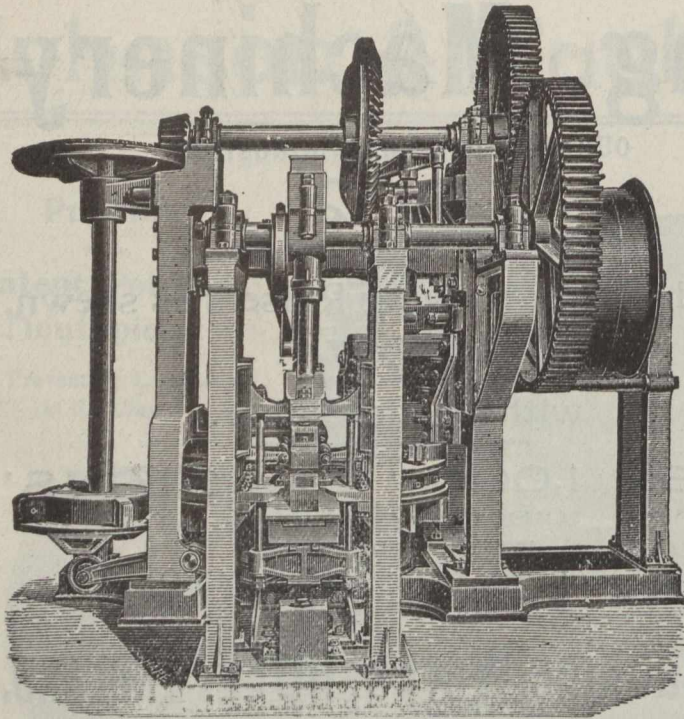

Craven's Patent Brick Moulding and Dressing Machines.

BRICK MACHINERY

For Working all kinds of Clay.

The stiff or semi-plastic system of Brick-making for producing a dense plastic pressed brick ready for immediate removal to the kiln was invented by us 28 years ago, and it is most successfully working in nearly all parts of the world.

Double the Strength of any other Machines in the Market.

Brick plants for producing the best plastic-pressed facing bricks on the most economical system. Awarded Three Highest Medals at Adelaide Exhibition, and the ONLY Gold Medal for Brick Machinery at the Melbourne Exhibition, 1888-9.

Bradley & Craven,
LIMITED
Westgate Common Foundry, WAKEFIELD, Eng.

Manufactured for the Canadian Market, under the new Preferential Tariff, 33½ per cent. in favor of English Goods.

STEAM YACHT FOR SALE.

(Dimensions, 55 ft. x 9 ft. over all.)

Cost over \$7,000 to build and equip. Oak frame; silk plush cushions; fine upholstery; speed, 12 to 14 miles an hour. Draft 4 ft. to 4½ ft. Machinery, &c., all in good order.



Apply to **M. S. FOLEY,**

"Journal of Commerce,"

171-3 St. James Street,

MONTREAL.

figures. Pound rolls, 17c to 18c; best quality crocks, tubs, etc., 16c to 17c; medium bulk, 14c to 15c; creamery, 20c to 21c, as to style.

Eggs.—Inferior quality still disappoints buyers and prevents liberal transactions, keeping the market irregular. Best obtainable are sold at 12½c; held fresh, 11½c to 12c; inferior, 8c to 9c.

Potatoes—Scarcity rules and keeps prices at \$1.10 to \$1.25 for good new stock in small quantities. No carlots visible as yet.

Hops.—Market dull at 13c to 14c per lb.

Hides.—Steers sell at 8¾c lb., and cows at 7½c; cured, 8½c for cows and 9½c for steers.

Wool.—Market depressed. Large offerings of fleece, but little doing. Prices, 12c to 13c, for washed and 7½c to 8c for unwashed. Pulled, 15c to 15½c for supers and 17c to 17½c for extras.

—If the promoters of the electric railroad projects and the Electrical Inspector of the New York state railroad commission are to be credited, an electrical road from Buffalo to Boston is not at all improbable in the near future, says a Rochester dispatch. Rochester is the centre of a network of electric roads already in operation or in progress of develop-

FLETCHER & SHAW, GOVERNMENT & RAILWAY CONTRACTORS,

Ryburn Leather Works,
SOWERBY BRIDGE, ENGLAND.

Telegram—"Fletcher & Shaw Sowerby Bridge"

Manufacturers of every description of

Leather Belting,
Laces, Picking Bands,
Combing Leathers, &c.

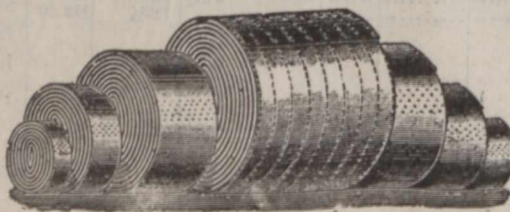

Telephone No.—0980, Halifax.

Cotton, Hair
and Link Belting, &c

Special prices to Canadians under the new Canadian Tariff.

"Sun" Ventilating Fans

Highest Efficiency, Strength
and Lightness

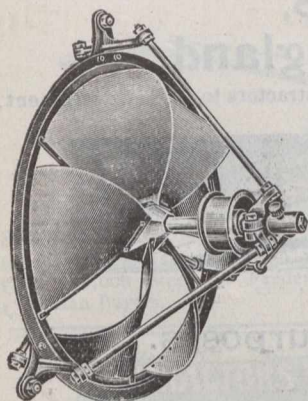

Belt Driven.

MADE ENTIRELY OF WROUGHT
OR MALLEABLE IRON.

For Ventilating, Drying and
All Cooling Purposes . . .

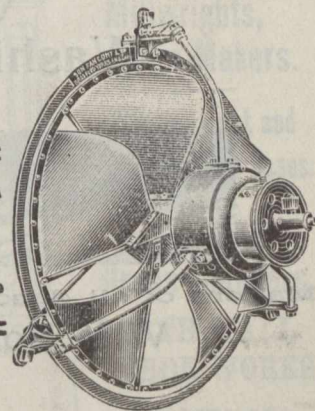

Electrically Driven.

"Sun" Fan Co. Ltd.,

GENERAL BUYING
AGENTS WANTED.

Special prices to Canadians
under the New Tariff.

40a Thornton Road, BRADFORD, ENG.

ment. The Rochester, Lockport and Buffalo railway company has just been granted a franchise by the state railroad commission to build an electric line from Rochester to Buffalo. It is capitalized at \$3,500,000. Franchises are asked for by the Genesee and Orleans company to build a line from Batavia to Oak Orchard, 27 miles; the Monroe county belt line, to run through the villages of Brighton, Fairport, Pittsford, Penfield, and Despatch, 20 miles; the Rochester and Eastern railway company, to construct a line from Rochester to Geneva, 65 miles; Rochester and Sullivan traction company, to build a line from Rochester to Dansville, 78 miles. It will thus be seen that Rochester is the centre of the most aggressive electric road movement along the whole line of similar movements extending from Buffalo to New York city. New York city does not mark the end of the experiment. Charles R. Barnes, the commissioner, said last week: While in the metropolis recently I made a

trip over the new line just completed from Port Chester to One Hundred and Thirty-second street, paralleling the New York, New Haven and Hartford Railroad. It has four tracks, uses the third rail system, and has not a single grade crossing. It marks the beginning, I am told of an electric line that is to parallel the New Haven road clear to Boston.

ORILLIA AND COUCHICHING.

Orillia and Couchiching, two names with a subtle aroma of romance in their very euphony, the one a Spanish word and the other of Indian origin, are nearly always coupled in describing one of the most beautiful summer resort districts in the famous "Highlands of Ontario." Orillia names the town, one of the prettiest and most picturesque in all Canada, and Couchiching, the lovely lake on whose shores it is built. This was a famous summer resort thirty years

ago, but with the destruction by fire of the famous Couchiching Hotel and the opening up of newer and wilder regions, there was a slight falling off for some years, though there were still many who loved the lake for its quiet and beauty and who came annually to spend their summers on its shores. Of late years there has been a remarkable revival in its popularity, as more people have begun to learn of the not easily equalled combination of attractions offered, fine scenery, capital fishing, a health-giving atmosphere, endless means of amusement, and all the comforts and conveniences that go to make life itself a pleasure, to be had for the asking.

The Grand Trunk Railway System recognizing the unlimited attractions of the district situated in the vicinity of Orillia and the unexcelled facilities for the accommodation of summer tourists, have issued a handsomely illustrated publication dealing with the special features and attractions of the locality. The brochure also

PATENT BRICK MACHINERY

Telegraphic Address:
"CAMBRIAN, LEEDS"

PULLAN & MANN,

(Successors to THOMAS TITLEY.

ENGINEERS,

Cambrian Works, Elland Road, - LEEDS, Eng.

MAKERS OF

Patent and Improved Brick, Tile and Sanitary Pipe-Making Machinery, Engines, Boilers, Shafting, Gearing, Pulleys, &c.

Complete Catalogue on application.

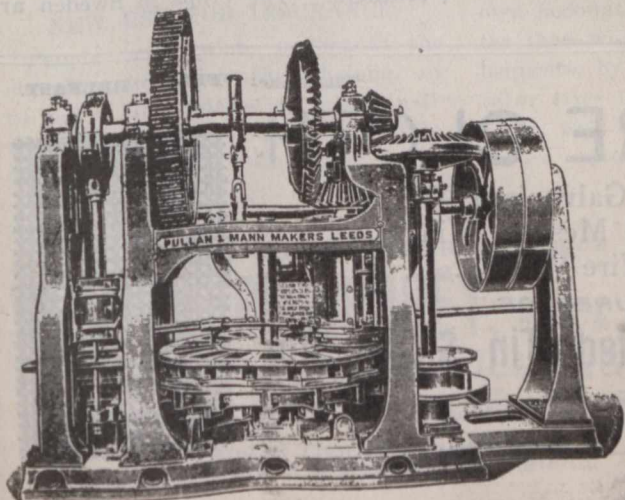

Special prices to Canadians under the New Canadian Tariff.
33½ p.c., off Tariff in favour of English Manufacturers.

The above Machine will produce from marl, shale, fire-clay, pit-refuse, &c. 10,000 to 12,000 best quality pressed bricks per day, stiff enough to go direct to kiln without expense of drying, and equal in strength and density to a well-made plastic brick.

R. S. NEWALL & SON, LIMITED.

(Founded by R. S. NEWALL, Original Patentee.)

WIRE ROPE WORKS,
 Washington, Co. Durham, = = England.

Contractors to H.M. Government.

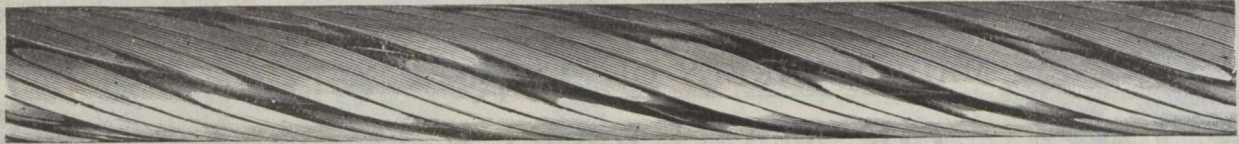

Makers of all descriptions of

Wire Ropes for Mines, Tramways and other purposes.

LONDON OFFICE—11, QUEEN VICTORIA STREET, E.C.

GLASGOW OFFICE—19, ROYAL EXCHANGE SQUARE.

Sole Makers of... **NEWALL'S PATENT MICROMETER WIRE GAUGE.**

ESTABLISHED 1846.

JOSEPH GREEN & NEPHEW,

"GLOBE IRON WORKS,"

LEEDS, Eng.

Manufacturers of all kinds of
 Hand and Steam Power

WOOD WORKING MACHINERY,

DRAWINGS & FULL PARTICULARS ON APPLICATION.
 LIBERAL DISCOUNT TO MERCHANTS & SHIPPERS.

All Machines are of the Best Materials, High Class Workmanship and Finish and
 thoroughly tested before leaving the works.

Telegraphic Address: "GREEN-NEPHEW," Leeds, Eng.

touches on some of the attractive spots on Lake Simcoe, Bass Lake and the Severn River. It deals in a truthful spirit with what may be expected by the fisherman and amateur angler. A chapter on the hotel accommodations with a list of hotels and boarding houses and prices per day and by the week is also embodied. It tells how to reach Orillia and gives authentic information to the tourist from the United States regarding customs arrangements. In all it is a most comprehensive pamphlet of invaluable aid to the summer traveller and will be sent free to anyone applying to G. T. Bell, G. P. and T.A., Montreal.

HUNGARIAN CROPS.

The official estimates for the forthcoming Hungarian crops place wheat at 35,000,000 metric centners, which is 3,000,000 metric centners, below the production of 1900. The quality of this wheat is considerably below the expectations. The rye crop is estimated at from 11,500,000 to 12,000,000 metric centners, which is somewhat above the crop of 1900. Barley is estimated at 10,000,000 centners, which is a decrease of 1,500,000 centners. Oats is estimated at from 9,500,000 to 10,000,000 centners, being a decrease from last year's production of 750,000 centners. The crops in Sweden are

Established 1829.

TELEGRAMS: "FELT," BELFAST.

WOVEN WIRE CLOTH

Brass, Copper, Iron and Galvanized Wire
 Cloth in all Strengths and Meshes, Mining
 Screens and all kinds of Wire Work. . . .

SOLE MANUFACTURER OF

Rogers Celebrated Perforated Tin Sieves for
 Meal Milling, &c.

SAMPLES AND PRICES FROM

JOHN ROGERS,

19 & 21 Queen's Square, BELFAST, Ireland.

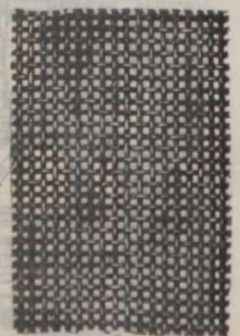
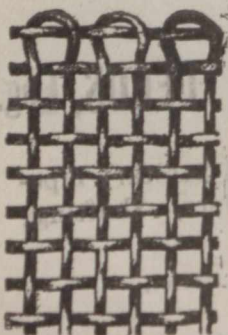

T. F. Braime & Co., L't'd.,

Goodman Street
HUNSLET, LEEDS, ENGLAND.

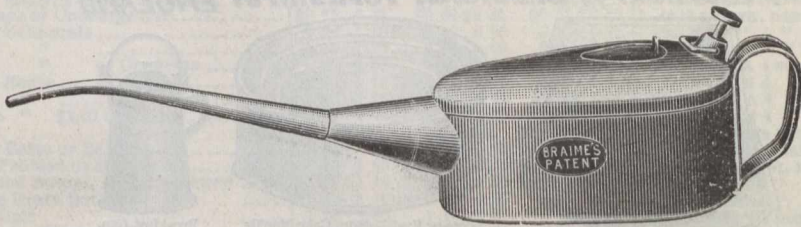

Manufacturers of every description of AIR CANS, AIR FEEDERS for all purposes, in Seamless Steel, Copper, Brass, largest makers in the U.K. Shippers to all parts of the world. Sole Contractors for PATENT STEEL OIL CAN to the Admiralty, from 1893 to 1902 inclusive. Over 100,000 Steel Air Feeders and Lamps, supplied to this dept. alone. Special terms to Canadian Buyers.

CONTRACTORS TO HER MAJESTY'S GOVERNMENT
BY ROYAL LETTERS PATENT

NO PAINT, NO PUTTY,
IMPERISHABLE WORKS,
WATER-TIGHT

THE ONLY DUST-PROOF SYSTEM

HEYWOOD'S

LONDON OFFICE
39, VICTORIA ST. WESTMINSTER, S.W.

TELEPHONE No 254 HUDDERSFIELD

GLASS GLASS
LEAD BAR
SMALL FULL-SIZE Steel
BAR SECTION Galvanized

COMBINATION SYSTEM

No OUTSIDE FASTENINGS to break off.

ADOPTED BY ALL THE LEADING ARCHITECTS & ENGINEERS THROUGHOUT THE BRITISH ISLES.

WH. HEYWOOD & CO. Glazing, Roofing Engineers, HUDDERSFIELD, ENGLAND.

GLAZING HUDDERSFIELD. TELEGRAPHIC ADDRESS

SYDNEY, N.S.W. 335, PITT ST.

Asbestos Packing

also seriously suffering as a result of the continued hot weather. Fires have devastated the forests of Jentland, Western Gotland, and the Smaland and Upland districts.

NEW USE FOR INSURANCE.

People who wish to benefit the churches to which they belong, or to endow universities or public institutions of any kind, such as hospitals, can select the one which they desire

to benefit, and, by taking out an endowment policy, or even a whole life policy (it being simply a matter of magnitude of premium) can secure substantial aid in the future to the institution in question, at a very moderate annual expenditure on their own account. This plan seems better than what we may call death-bed bequests, by which, perhaps, the testator tries to compound for the sins of his past life in the hope of getting future advantage, sometimes, possi-

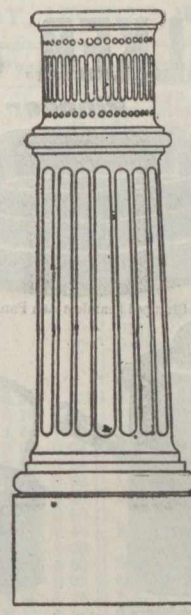

ROSS & WALPOLE,

Limited,

Engineers,
Millwrights,
Boiler-Makers.

Electric Light and
Tramway Pole Bases.

Iron and
Brass Founders,
NORTH WALL
IRON WORKS,
DUBLIN,
IRELAND;

MANTELS,
TILES,
MOSAICS,

TRANSOM
and PAVEMENT
PRISMS.

WEBSTER BROS. & PARKES,

228 ST. JAMES ST.,

MONTREAL, Que.

bly, to the detriment of those nearest to him. This is another illustration of the vast and far-reaching possibilities of life insurance business, and one which is worthy the attention not merely of persons of large means, but of all those who can set aside even a small sum out of their annual income for the purpose of assisting in the cause of charity.

BOUNTIES ON PIG IRON.

Additional regulations governing the payment of bounties upon iron and steel made in Canada have been approved by the Governor-General, and are issued by the Department of Trade and Commerce, for the information of all concerned. Under the act of last session these bounties which had hitherto been paid by the Department of Customs will hereafter be paid by the Department of Trade. The bounty on steel ingots is \$3 a ton if manufactured before April 23rd,

Telegrams:—"PUMPHREY, Glasgow"

W. & M. PUMPHREY, Bridal & Banquet Sugars.
SUGAR MILLERS,
Crownpoint Road, - Glasgow, Scotland.

And at Thornaby-on-Tees,
London & Manchester England.

Icing
and
Caster

SUGARS

as
they
Should
be!

Special Prices to Canadians
under the New Tariff.

WALKER & HOLROYD, GENERAL STAMPERS, PIERCERS,
AND SHEET METAL WORKERS,
Pioneer Works, Thornbury, Bradford, Yorkshire. ENGLAND



Special Prices to Canadians under the New Tariff.

1902. Thence, by a descending scale the bounty is reduced each year until in 1907 it is 60 cents per ton. The bounty will not be paid until the manufacturer has furnished to the Government satisfactory evidence that such steel ingots were manufactured in Canada from ingredients of which not less than 50 per cent. of the weight thereof consisted of pig iron made in Canada. This evidence must be taken upon oath before a collector of customs or a justice of the peace. The bounty on puddled iron bars is the same as on steel ingots, but it is necessary for the manufacturer to produce evidence that the

bars were manufactured from Canadian pig iron. The bounty on pig iron is to expire on the first day of July, 1907. Commencing the first year the bounty on pig produced from Canadian ore is \$3 per ton, and on pig iron from foreign ore \$2. The proportionate difference is the same for the seven years that the bounty is to run.

THE PROCESS OF SUGGESTION.

A great boom to the advertising of patent medicines is given by the testimony of Dr. Sara C. Buckley, of Chicago before a Master in Chancery in

a suit to restrain the city of Chicago from interfering with advertising on billboards. She said there were people who, if they saw the advertisement of an eye specialist, would at once experience symptoms of eye trouble, and some of them came to her for treatment. "The same thing is true of advertisements of all kinds of medicine," she said. "People become convinced that they are afflicted with a disease when they see its remedy advertised. The process of suggestion is responsible for this, and the billboards are the cause of it." Every manufacturer of a patent medicine, then, can create a demand for his pro-

John Smith,
CRANE WORKS,
KEIGHLEY, Yorks,
ENGLAND.

SPECIALITIES

STONE SAW FRAMES
And DERRICK CRANES.

Nat. Telephone, 29 Keighley.
Telegraphic Address: "CRANES, KEIGHLEY."

Special prices to Canadians under the New Tariff.

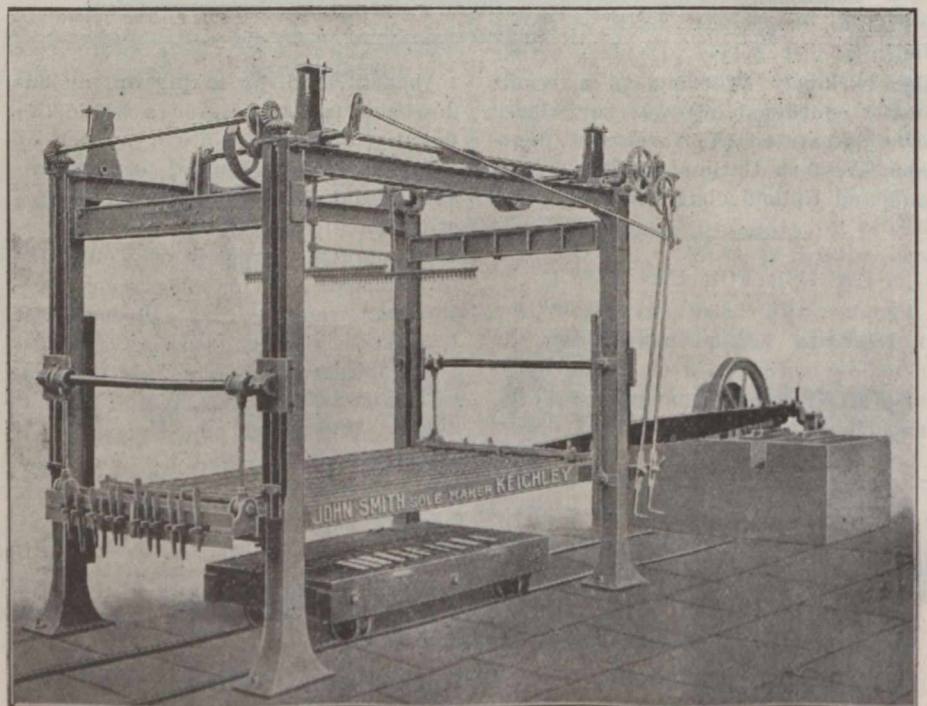

Considerably over 300 Saw Frames at work.

MONTREAL WHOLESALE PRICES CURRENT—THURSDAY, AUGUST 8, 1901.

Name of Article.		Wholesale.			Name of Article.		Wholesale.	Name of Article.		Wholesale
Boots and Shoes.				Brooms.		Heavy Chemicals.				
Brogans or Cobourgs		Mens.	Boys.	Youths.	Union Jack No. 5, pl. light			Bleaching Powder	2 00	3 00
Split Balmorals		\$0 75 0 85	\$0 60 0 65	\$0 55 0 60	Rose 4 varn. hand heavy..	0 00		Bine Vitriol	6 00	7 50
Kip		0 90 1 10	0 80 0 90	0 70 0 75	Pansy 4 " " medium	0 00		Brimstone	2 00	2 50
Buff " or Congress		1 10 1 20	0 95 1 00	0 80 0 85	Thistle 4 " " "	0 00		Caustic Soda 60	2 25	2 60
Split Boots		1 20 1 50	1 00 1 20	0 90 1 00	Map Leaf A 4 stgs.	0 00		" " 70	2 50	2 75
Kip		1 30 1 75	1 10 1 25	0 90 1 00	" B 4 " stained	0 00		Soda Ash	1 25	1 50
Grain " \$3.00 to \$3.00		2 10 2 75	1 50 1 75	1 10 1 30	Shamrock A 4 " varn han	0 00		Soda Bicarb	1 75	2 25
		2 10 2 75	1 50 1 75	1 10 1 30	" B 4 " stained	0 00		Sal. Soda	0 75	0 85
					Daisy A 3 stgs varn handle	0 00		" Concentrated	1 50	2 00
					" B 3 " stained "	0 00		Dyestuffs.		
					Tulip No. 1 3 st. med lt.	0 00		Archil. con	0 27	0 29
					" 2 3 " light	0 00		Cutch	0 06	0 09
					Curling 4 " ord.	0 00		Ex. Logwood	0 09	0 12
					Warehouse 4 heavy	0 00		Chip	1 75	2 50
					E. 3 str. bamboo handle..	0 00		Indigo (Bengal)	1 50	1 75
								Indigo Madras	0 70	1 00
								Gambier	0 05	0 06
								Madder	0 09	0 12
								Sumac	60 00	65 00
								Tin Crystals	0 25	0 30
								Fish.		
								Bloaters, per box	0 00	0 00
								Labrador Herrings, N.F.	0 00	0 00
								No. 1 Shore Herrings	0 00	0 00
								" Nova Scotia	0 00	0 00
								Mackerel No. 2, brls.	0 00	15 50
								" " 1/2 barrel.	0 00	8 00
								Green Cod, No. 1	0 00	0 00
								Green " large	0 00	0 00
								No. 2 "	0 00	0 00
								Large dry Gaspe per quint.	0 00	0 00
								Salmon, brls Lab.	12 50	14 00
								Salmon, (half brls)	0 00	7 00
								" Brit. 601 brls.	0 00	14 00
								Boneless Fish	0 04	0 00
								" Cod	0 05	0 06
								Skinless Cod, case	0 00	4 75
								N. S. Salt Herrings, in		
								half-barrels.	2 50	3 00
								Salt Lake Trout, half-brls	0 00	0 00
								Salt Whitefish	0 00	0 00
								Loch Fyne Herrings, keg	1 10	1 15
								Flour.		
								Winter Wheat patents	3 65	3 90
								Manitoba patents	4 10	0 00
								Straight roller	3 30	3 40
								do bags	1 60	1 70
								Strong Bakers	3 80	0 00
								Superfine	0 00	0 00
								Rolled Oats	3 80	3 90
								Corn meal, bag	1 20	1 25
								Bran bulk	15 00	00 00
								Shorts	17 00	00 00
								Mouille	22 00	25 00

Name of Article.	Wholesale.	Name of Article.	Wholesale.
Canned Goods.			
Lobsters, 1/4 s to 1 lb.	\$ 1 75 3 25	Corn Beef 1-lb	1 50 1 65
Sardines, 1/4	7 00 17 00	" 2-lbs	2 75 3 00
Canadian Sardines	3 75 4 00	" 4-lbs	5 12 0 00
Mackerel	1 00 1 10	" 6-lbs	8 65 9 75
Salmon, 4 doz. case	3 60 6 00	" 14-lbs	19 00 21 60
Clams, 1-lb tins, per doz.	1 20 1 60	Lunch Tngs 1-lb per doz.	3 00 3 45
Oysters	1 15 1 40	" 2-lbs	6 00 6 80
Tomatoes, 3s. per doz.	0 80 0 90	Ox Tongue, 1 1/2-lb.	0 00 0 50
Peaches, 2-lb.	1 65 1 80	" 2-lb.	8 00 10 80
Pears, 2-lb. tins, per doz	2 25 2 50	" 2 1/2-lb.	0 00 12 50
Strawberries, Pres'd 2s	1 50 1 60	" 3-lb.	0 00 13 75
Raspberries 2s.	1 45 1 65	Deviled Tong's, 1/4 lb.	1 00 1 15
Pineapples, 3-lb tin, p. doz	2 30 2 40	Ham, 1/2-lb.	1 00 1 15
Gooseberries Pres. 2 s.	0 00 1 50	Chicken, 1/4-lb.	1 00 1 85
Gr'n Gages, 2-lb. tins, p. d.	1 30 1 50	Turkey, 1/2-lb.	1 00 1 85
Blue Plums, 2 lbs.	1 00 1 10	Soups, lbs.	1 30 1 95
corn, 2 lb. tins.	0 80 0 85	" 1 1/2 lb.	1 15 1 90
Peas, 2-lb tins.	0 80 0 90	3 lb Baked Beans	0 00 1 65
String Beans	0 80 0 85	Sliced Bacon, 1/4 lb.	0 00 3 00
		" 1 lb.	0 00 3 00
		Ham, 1 lb.	0 00 3 00

JOHN MACKINTOSH LTD



EXTRA CREAM

TOFFEE

MANUFACTURING CONFECTIONERS

HALIFAX ENGLAND

TELEPHONE NO 453
TELEGRAMS: MACKINTOSH
CONFECTIONERS HALIFAX

DEPOTS:
90 Holloway Road,
London, Eng.;
447 Moseley Road,
Birmingham, Eng.

DEPOTS:
School Street,
Dewsbury;
Also at Sheffield.

EXTRACT of INDIGO.
REDUCED INDIGO.

J. W. EASTBURN,
Raglan Chemical Works,
HALIFAX, ENGLAND.

Special prices to Canadians under the new Canadian Tariff.

duct. He has only to advertise a remedy for insanity and a certain portion of the public will believe itself insane, and while a few of these will go to their own physicians, much the greater part will buy his infallible mind cure.

INDIVIDUAL ACTION.

Prophecy is the most gratuitous form of mistake, but we venture to believe that better insurance conditions will slowly but surely arrive; not, perhaps, along the line of any

general agreement, for which so many seem to be expectantly waiting, but by compelled individual action of officers, managers and agents. The impressive lessons of the last two years must have their influence. Companies have failed, some bringing serious trouble to their agents and policyholders; others have retired and the expirations of their agents have gone into rival offices. Still others are quite likely to discontinue, for it takes a robust company to stand the prevailing unhealthy insurance atmosphere. Even those companies which will not

MONTREAL WHOLESALE PRICES CURRENT—THURSDAY, AUGUST 8, 1901.

Name of Article.	Wholesale	Name of Article.	Wholesale	Name of Article.	Wholesale	Name of Article.	Wholesale		
	\$ c. \$ c.		\$ c. \$ c.		\$ c. \$ c.		\$ c. \$ c.		
Farm Products.				Grain					
Butter: Choicest Cr.....	0 21 0 21	No. 1 Hard, Man. Lake & R.	0 83 0 81	Molasses (Barbados).....	0 25 0 29	Vermicelli, Canadian.....	0 05 0 06		
Export lots.....	0 20 0 20	No. 2, " ".....	0 81 0 79	do bris. & 1/2s.....	0 31 0 32	Macaroni, ".....	0 05 0 06		
2nd Grade do.....	0 19 0 19	No. 3, " ".....	0 77 0 75	Evaporated Apples, ...	0 05 0 06	" Italian.....	0 10 0 13		
Townships Dairy.....	0 18 0 19	Oats, ex store.....	0 39 0 40	Essains:					
Western.....	0 16 0 16	Barley, No. 1, mid.....	0 00 0 00	Sultanas.....	0 09 0 12	Peel—Citron.....	0 14 0 16		
Good to choice.....	0 13 0 15	" No. 2, mid. ft.....	0 51 0 51	Loose Musc. Malaga... ..	0 08 0 10	Orange.....	0 11 0 13		
Fresh Rolls.....	0 00 0 00	Peas, afloat.....	0 79 0 80	Layers, London.....	0 00 2 40	Lemon.....	0 10 0 12		
CHEESE:				Rye.....	0 57 0 58	Chocolate			
Finest, col d.....	0 09 0 09	Buckwheat, afloat.....	0 56 0 00	Vanilla, yel. wrap. 24 x 1/2 lb					
Eastern.....	0 09 0 09	Groceries:		do Chamois do do					
Inferior.....	0 00 0 00	Tea, (Hf.-Chest & Cad.)..		do Pink do do					
Eggs: Strictly new.....	0 13 0 13	Japan, com. to med., B.....	0 14 0 18	do Blue do do					
Candled.....	0 11 0 12	good med. to fine.....	0 19 0 20	Tipt. Van. Green do do					
P. E. I.....	0 00 0 00	choicest.....	0 23 0 25	do do Lilac do do					
Cold storage.....	0 00 0 00	fancy.....	0 26 0 36	do do Bronze do do					
No. 2.....	0 10 0 11	dust.....	0 05 0 09	do do White do do					
Hors: N Y. State, per B.....	0 14 0 15	Y. Hyson, com. to good.....	0 13 0 20	Unsweet'd blue prem do					
Pacific Coast, ".....	0 14 0 14	fine to finest, B.....	0 30 0 45	Starch:					
Canadian ".....	0 12 0 19	Gunpowder, Moyune.....	0 22 0 25	Can. Laundry.....					
German ".....	0 28 0 35	good.....	0 25 0 35	Silver Gloss.....					
English ".....	0 30 0 00	Pingsuey med to good.....	0 12 0 16	Benson's Prep. Corn.....					
British Columbia ".....	0 18 0 26	fine to finest.....	0 19 0 23	" Sat. Chr. label.....					
Hog Products:				Oolong.....	0 28 0 42	Can. Pure Corn.....			
Bacon, smoked, per B.....	0 14 0 15	Congou, common.....	0 10 0 16	No. 1 Wh. blue 48 lb.....					
Hams, city cured, ".....	0 13 0 14	good common.....	0 17 0 20	" 100 lb.....					
Pork Ca. s.c. per bbl.....	0 00 19 00	med. to good.....	0 22 0 27	" 50 lb.....					
do mess.....	18 00 18 50	fine to finest.....	0 32 0 35	" 25 lb.....					
Dressed Hogs, light.....	9 50 10 00	Indian.....	0 15 0 28	" 10 lb.....					
do heavy.....	9 00 9 25	Darjeelings.....	0 35 0 45	" 5 lb.....					
Lard, per B Can pure.....	0 11 0 11	Ceylon.....	0 15 0 35	" 2 1/2 lb.....					
Com. Refined.....	0 07 0 08	Coffees, Mocha (green).....	0 25 0 26	" 1 1/2 lb.....					
SEEDS:				Java.....	0 17 0 18	" 3/4 lb.....			
Clover, red, per lb.....	0 12 0 14	Maracabo.....	0 17 0 18	" 1/2 lb.....					
do alsike.....	0 12 0 15	Jamaica.....	0 17 0 18	" 1/4 lb.....					
Timothy, (Can'n) per bah.....	3 00 3 40	Rio.....	0 11 0 15	" 1/8 lb.....					
do Western.....	2 50 3 00	Plantation Ceylon.....	0 27 0 29	" 1/16 lb.....					
Flax 56 lbs.....	0 06 2 00	Chicory.....	0 06 0 11	" 1/32 lb.....					
Fall Rye.....	0 80 0 85	Canadian do.....	0 00 0 06	" 1/64 lb.....					
Millet.....	0 98 1 00	Sugars: Factory.		" 1/128 lb.....					
Hungarian.....	0 85 0 90	Ex Granulated, bris.....	0 00 4 50	" 1/256 lb.....					
SUNDRIES:				German gran'd.....	0 06 0 00	" 1/512 lb.....			
Potatoes, (old) per bag.....	0 42 0 50	Ex Ground, in bris.....	0 00 5 05	" 1/1024 lb.....					
Honey, White Clov., Comb.....	0 12 0 13	" in bxs.....	0 00 5 25	" 1/2048 lb.....					
do Extracted.....	0 08 0 10	Powdered, in bris.....	0 00 4 80	" 1/4096 lb.....					
Beeswax.....	0 25 0 30	boxes.....	0 00 5 05	" 1/8192 lb.....					
Beans: prime.....	1 40 1 50	Paris Lumps, in bris.....	0 00 5 05	" 1/16384 lb.....					
do. Best hand-picked.....	0 00 0 00	" half bris.....	0 00 5 15	" 1/32768 lb.....					
Sugar Maple.....	0 09 0 10	" 100-lb bxs.....	0 00 5 05	" 1/65536 lb.....					
Syrup Maple, tins.....	0 65 0 70	" 50-lb bxs.....	0 00 5 15	" 1/131072 lb.....					
do wood, lb.....	0 07 0 07	Branded Yellows.....	3 85 4 35	" 1/262144 lb.....					

"Robisco" White Metal,

(REGISTERED.)

THE STANDARD OF PERFECTION.

REGISTERED TRADE MARK.

FOR
MARINE,
RAILWAY,
TRAMWAY,
MINING,

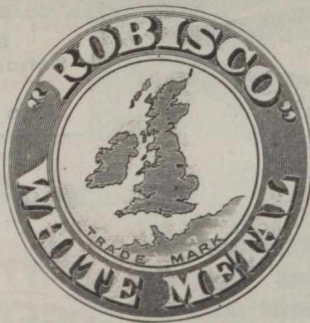

ROLLING MILLS,
DYNAMOS
And
GENERAL
MACHINERY
BEARINGS.

PRICES ON APPLICATION.

...SOLE PROPRIETORS

Robert Bowran & Co., 3 St. Nicholas' Buildings, Newcastle-upon-Tyne, England.

retire and have the vigour of a strong surplus are not likely to continue satisfied with enjoying poor health, so that altogether, it is reasonable to expect that companies, each for itself, will determine, more or less resolutely, for better compensation and reduced expenditure, even if business goes from their books.

ONTARIO'S IRON INDUSTRY.

The manufacture of pig-iron in Ontario by modern methods dates back only to 1896. Since 1897, the Ontario government has given a bounty of

one dollar a ton on pig iron made from Ontario ores. Until December last, when the new furnace at Midland was put in blast and began to use ore from the Helen Mine, the Ontario ores were from small and only moderately successful mines along the Kingston and Pembroke railway. In 1899, the last year for which the statistics have been officially published, 24,000 tons of Ontario ore, or 22 per cent. of the amount required was used at the two then existing furnaces at Hamilton and Deseronto. The rest of the ore was imported from the United States. The eastern On-

ESTABLISHED 1805.

WILLIAM WHITE & SON,

ABSORBENT PIPE

Glasgow, Scotland,
THE LARGEST
Clay Tobacco Pipe
Manufacturers in the World.

OF ALL DEALERS

tario ore carries but a low percentage of iron, and is not likely to be increasingly used now that there is a vast supply in the Michipicoton country. In 1899, 64,700 tons of pig iron were produced in Ontario. By far the larger part of it at the furnace of the Hamilton Iron and Steel Company on Lake Ontario at Hamilton.

The furnace at Hamilton has a capacity of 150 tons. There are also two open hearth furnaces; and until the works at Sydney and Sault Ste. Marie are complete, the Hamilton plant will rank as the best equipped in Canada. It ranks with the best

MONTREAL WHOLESALE PRICES CURRENT—THURSDAY, AUGUST 8, 1901.

Name of Article.	Wholesale.	Name of Article.	Wholesale.	Name of Article.	Wholesale.	Name of Article.	Wholesale.
Hardware.		Oil Chain—No. ½	\$ 70 0 00	Lead Pipe, per 100 lbs. ..	7 09 0 00	Tallow, cake	0 00 0 06
Antimony.....	0 09 0 10	9-16.....	3 60 0 00	less 30 p.c.		" rendered.....	0 05 0 06
7/16 Block, L & F, # 10.....	0 00 0 32	¾.....	3 50 0 00	Zinc:		" Ordinary.....	0 04 0 04
" Straits.....	0 00 0 00	¾.....	3 55 0 00	Spelter, per 100 lbs.....	0 00 4 75	" rough.....	0 02 0 02
" Strip.....	0 00 0 32	1 in.....	3 45 0 00	Sheet, Zinc "	5 75 6 00		
Copper: Ingot.	0 00 0 00			Black Sheet Iron.		Leather	
CUT NAIL SCHEDULE.		Galvanized Staples—		Per 100 lbs.		No. 1 B. A. Sole.....	0 27 0 28
Base Price, per Keg, car lots	2 35 0 00	100 lb. box, 1½ to 1¾....	3 50 0 00	8 to 16 gauge.....	2 65 0 00	No. 2 B. A. Sole.....	0 25 0 26
Extras—Over and above 30d,	2 45 0 00	Bright, 1½ to 1¾.....	3 25 0 00	18 to 20 do.....	2 50 0 00	No. 3 B. A. Spanish Sole	0 24 0 24
40d, 50d, 60d and 70d Nails.		Galvanized Iron:		22 to 24 do.....	2 65 0 00	Slaughter, No. 1.....	0 28 0 29
Cut and Fence Nails—		Queen's Head, } gauge 28	4 40 4 65	26 do.....	2 70 0 00	Light medium & heavy..	0 28 0 29
16 and 20d Hot Cut, per 100 lbs	0 05 0 00	or equal.....	4 00 4 25	28 do.....	2 75 0 00	No. 2.....	0 26 0 27
10 and 12d ".....	0 10 0 00	Comet do 28 gauge.....	4 00 4 25			Harness.....	0 26 0 30
8 and 9d ".....	0 15 0 00			WIRE:		Upper, heavy.....	0 34 0 36
6 and 7d ".....	0 30 0 00	Iron Horse Shoes:		Plain galv'd, No. 5.....	4 00 0 00	Upper, light.....	0 35 0 37
4 and 5d ".....	0 40 0 00	No. 2 and larger.....	0 00 3 50	do do No. 6, 7, 8	3 50 0 00	Grained Upper.....	0 34 0 35
3d ".....	0 65 0 00	No. 1 and smaller.....	0 00 3 75	do do No. 9.....	2 85 0 00	Scotch Grain.....	0 35 0 38
2d ".....	1 00 0 00			do do No. 10.....	3 60 0 00	Kip Skins, French.....	0 60 0 65
Cut spikes 10c, per Keg advance.		Bar Iron, per 100 lbs.		do do No. 11.....	3 00 0 00	English.....	0 45 0 55
Fine blued nails—		Car lots.....	0 00 0 00	do do No. 12.....	3 00 0 00	Canada Kip.....	0 50 0 60
2d per 100 lbs.....	1 00 0 00	Norway, base.....	0 00 4 25	do do No. 13.....	3 10 0 00	Hemlock Calf.....	0 50 0 70
3d ".....	1 50 0 00	Am. Sh. St'l, 6 ft. x 2½ ft., 18	0 00 2 70	do do No. 14.....	4 10 0 00	" Light.....	0 50 0 60
Casing, Box, Tobacco Box		" " " 20	0 00 2 95	do do No. 15.....	4 60 0 00	French Calf.....	0 85 1 10
and Flooring Nails—		" " " 22	0 00 3 10	do do No. 16.....	4 85 0 00	Splits, light and medium.	0 22 0 25
20 to 30d per 100 lbs.....	0 55 0 00	" " " 24	0 00 3 10	do do No. 17.....	3 05 f.o.b.	" heavy.....	0 17 0 20
10 to 16d ".....	0 60 0 00	" " " 26	0 00 3 20	do do No. 18.....	Montreal,	" small.....	0 18 0 20
8 and 9d ".....	0 65 0 00	" " " 28	0 00 3 45	Barbed Wire—		Leather Board, Canada...	0 66 0 10
6 and 7d ".....	0 70 0 00	Boiler plates, iron, ¼ in.	0 00 2 10	Spring Wire per 100, 1.00		Enameled Cow, per ft....	0 16 0 18
4 to 5d ".....	0 95 0 00	" " " 3-16 in	0 00 2 10	net extra.		Pebble Grain.....	0 12 0 14
3d ".....	1 20 0 00	Hoop Iron, base for 2 in.	0 00 2 65	Iron and Steel Wire pl'n		Glove Grain.....	0 12 0 13
Finishing nails—		and larger.....		6 to 9.....	2 80 base.	B. Calf.....	0 15 0 20
¾ inch and longer per 100 lbs	0 60 0 00	Band Canadian, 1 to 6 in.		Rope.		Brush (Cow) Kid.....	0 11 0 13
2¼ and 2½ inch.....	0 65 0 00	30c; over base of ordin-		Sisal, base.....	0 00	Buff.....	0 13 0 16
2 and 2¼ ".....	0 70 0 00	iron, smaller size Extras		" 7-16 and up....	0 10	Russets, light.....	0 35 0 40
1½ and 1¾ ".....	0 95 0 00	Canada Plates:		" 5-16 ".....	0 10	" heavy.....	0 25 0 30
1¾ and 1½ ".....	1 20 0 00	Full Polish.....	3 25	" ¼ ".....	0 10	" No. 2.....	0 35 0 40
1 ".....	1 50 0 00	Ord. 52 sheets.....	2 60	" 3-16 ".....	0 10½	Saddlers' doz... ..	7 50 9 00
Slatting nails—		" 60 do.....	2 65	Manilla, 7-16 & lgr. ..	0 13½	Imt. French Calf.....	0 65 0 75
1½ and 1¼ inch per 100 lbs..	0 95 0 00	" 75 do.....	2 70	" 5-16 ".....	0 14	English Oak lb.....	0 30 0 35
1¾ ".....	1 20 0 00	Black Iron pipe, ½ in. & 1 in.		" ¾ ".....	0 14½	Dongola, extra.....	0 38 0 42
1 ".....	1 50 0 00	¾ in.....	2 72	" 1 ".....	0 15	Glove, extra.....	0 20 0 22
Common barrel nails—		1 in.....	2 87	" 1½ in.....	0 15½	Colored Pebbles.....	0 14 0 16
1½ inch per 100 lbs.....	1 00 0 00	1¼ in.....	4 60	" 2 in.....	0 09½	" Calf.....	0 18 0 22
1 ".....	1 00 0 00	per 100 ft. nett.		Wire Nails.		Oils	
¾ ".....	1 25 0 00	Steel, cast p.lb., Blk Diam'd	0 08 base	Base Price carload.....	2 77½	Cod Oil.....	0 85 0 40
¾ ".....	1 50 0 00	" Spring, 100 lbs.....	2 75 0 00	Less than ".....	2 85	S. R. Pale Seal.....	0 50 0 55
Oilinch nails—		" Tire, ".....	1 95 base	2d f ".....	1 00	Straw Seal.....	0 40 0 50
¾ inch and longer per 100 lbs	0 60 0 00	" Sleigh shoe, 100 lbs..	1 85 base	3d ".....	0 65	Cod Liver Oil, Ndd. Norw	
2¼ and 2½ inch.....	0 65 0 00	" Toe Calk.....	2 25	4d and 5d ".....	0 40	Process.....	0 85 1 00
2 and 2¼ ".....	0 70 0 00	" Machinery.....	2 75 base	6d and 7d ".....	0 30	" Norwegian.....	0 95 1 10
1½ and 1¾ ".....	0 95 0 00	" Harrow Tooth.....	2 50	8d and 9d ".....	0 15	Castor Oil.....	0 09½ 0 10
1¾ and 1½ ".....	1 20 0 00	Tin Plates:		10d and 12d ".....	0 10	Castor Oil brls.....	0 00 0 09½
1 ".....	1 50 0 00	IC Coke, 14 x 20.....	4 50	16d and 20d ".....	0 05	Lard Oil, Extra.....	0 75 0 85
Sharp and flat pressed nails		IC Charcoal, 14 x 20.....	4 75	30d to 60d ".....	Base	".....	0 65 0 75
¾ inch and longer per 100 lbs.	1 35 0 00	IX Charcoal.....	5 75	Hides and Tallow		Linseed, raw, nett.....	0 82 0 83
2¼ and 2½ inch.....	1 50 0 00	IXX ".....	6 50	Montreal Green Hides		" boiled, nett.....	0 85 0 86
2 and 2¼ ".....	1 85 0 00	Terne Plate IC, 20x25....	7 50 box	No. 1.....	0 07½ 0 00	Olive, pure.....	0 90 1 10
1½ and 1¾ ".....	2 50 0 00	Russ. Sheet Iron.....	0 10 0 00	No. 2.....	0 06½ 0 00	Extra, qt., per case.	0 00 3 70
1 ".....	3 00 0 00	Lion & Crown tin'd sh'ts..		No. 3.....	0 05½ 0 00	Turpentine, nett.....	0 54 0 55
Coil Chain—No. 5	0 11½ 0 00	22 and 24 gauge case lots	0 00 7 50	Fanners pay \$1 extra for		Petroleum:	
" 5.....	0 10 0 00	26 gauge.....	0 00 7 75	sorted, cured & inspect'd		Benzine.....	0 18 0 19
" 4.....	0 09½ 0 00	Lead: Pig, per 100 lbs; ..	3 70 3 80	Sheepskins.....	0 00 0 80	Gasoline.....	0 19 0 20
" 3.....	0 09 0 00	Sheet.....	0 00 0 04½	Clips.....	0 00 0 25	Silver Star.....	0 14½ 0 15½
¾ inch.....	0 07½ 0 00	Shot, 100 lb., less 17½ p.c.	0 00 6 50	Lambskins each.....	0 00 0 25	Imperial Acme.....	0 16 0 17
5-16.....	4 70 0 00			Calfskins, No. 1.....	0 00 0 10	American W. W.....	0 18 0 19
¾.....	4 10 0 00			" No. 2.....	0 00 0 08	Astral.....	0 18½ 0 19½
7-16.....	3 35 0 00			Horsehides.....	1 50 2 00		

American plants of its size. At Deseronto, charcoal iron is made chiefly from imported Lake Superior ore.

The Midland furnace is the latest addition to the Ontario iron manufacturing plants. It has been established by the Canada Iron Furnace Company, limited, of Montreal. Midland is a prosperous and growing lumber and grain centre on Georgian Bay. It has a magnificent harbour,

one of the best on Lake Huron; and is one of the industrial centres on the lake, which has been immensely benefited by the change of policy of three years ago. of the Ontario Government in connection with the sale of timber limits on crown lands. Until 1898, Americans were permitted to buy these limits, and float the logs cut from them across the lake to Bay City and other Michigan ports, where

they were sawn into lumber for the American market. When the Dingley Act, with its unprecedentedly high duty went into operation in 1897, the provincial government promptly retaliated by inserting in the conditions governing the sale of crown lands that the logs cut on them should be manufactured into lumber in Canada. A great howl was raised in Michigan, but the result of the new order has

Fulled Raw Hide Belting AND Laces.

Every Description of LEATHER for Mechanical Purposes.

Edward Fairburn & Sons,

Card Clothing of all Kinds.
CHROME and Oak Tanned Picking Bands...
Single "Cemented" Belting, Double Belting, Rubbing Leathers.

Caldervale Mills, BRIGHOUSE, Eng.

Special Terms to Canadians under the New Canadian Tariff.

MONTREAL WHOLESALE PRICES CURRENT—THURSDAY, AUGUST 8, 1901.

Name of Article.	Wholesale.	Name of Article.	Wholesale.	Name of Article.	Wholesale.	Name of Article.	Wholesale.
Class.	\$ c. \$ c	Salt—Continued.	\$ c. \$ c.	Capstan Cigarettes, 10s. 50s.	\$ c. \$ c.	Ports—	\$ c. \$ c.
United Inches, 00 to 25.....	0 00 2 10	Special Dairy, per brl.	2 00 2 50	Gold Flake, 10s, 50s.....	0 15 0 75	Tarragona.....	1 10 1 50
do 26 to 40.....	0 00 2 20	quarters	0 45 0 50	Three Castles, 10s, 50s.....	0 15 0 75	Sandeman.....	2 00 6 00
do 41 to 50.....	0 00 4 70	Spl Cheese Salt p bag 200 lb	1 25 1 50	Gold Tip, 50s, 100s.....	1 25 2 50	Warter & May's Ports gal.	2 10 6 50
do 51 to 60.....	0 00 4 95	Turk's Island per bush....	0 30 0 35	Gerth's Smoking, per lb....	0 00 1 60	Sherries—Per artin'	2 00 5 50
Paints, &c.		Tobacco—Cut Smoking.		Wool.		Wisdom & Warter's Sherries..... per gal.....	2 00 6 50
Lead pure 50 to 100 lb. kgs.	0 00 6 25	No. 1 Black Chewing, cads	0 50 1 65	Canadian Washed.....	0 12 1 02	Claret—	
do No. 1.....	0 00 5 87	No. 2 do	0 59 0 00	North West.....	0 14 0 15	St. Juliens.....	2 60 2 65
do No. 2.....	0 00 5 50	Old Chum, in pkg., 10s and	0 00 0 82	Unwashed.....	0 08 0 00	Barton & Guestier.....	4 00 25 00
do No. 3.....	0 00 4 75	12s	0 00 0 82	Pulled, combing.....	0 00 0 00	Nat. Johnson & Sons.....	4 00 25 00
do No. 4.....	0 00 4 75	Old Chum, in tins, lbs. and	0 00 0 82	do super.....	0 00 0 00	J. Calvet & Co.....	4 50 40 00
White Lead dry.....	5 50 5 75	1/4s	0 00 0 82	do extra.....	0 00 0 21	Champagnes—	
Red Lead.....	5 00 5 50	Old Chum, 1-5 tins.....	0 00 0 95	B. A. Scoured.....	0 25 0 35	Pommery, Fils & Co.....	28 00 30 00
Venetian Red Eng'h.....	1 75 2 00	Puritan, in pkgs., 1-11s	0 00 0 85	Natal.....	0 16 0 16	G. H. Mumm.....	28 00 30 00
Yel. Ochre, French.....	1 50 3 25	do 1/4 lb. tins.....	0 00 0 85	Cape, greasy.....	0 13 1 15	Perrier, Jonet & Co.....	28 00 30 00
Whiting, ordinary.....	0 45 0 50	do 1 lb tins.....	0 00 0 83	Chilian.....	0 12 0 13	Brandies—Hennessy ..gal.	7 00 8 50
do Gilders.....	0 60 0 70	Cut Cavendish, in pkg., 1-10s	0 00 0 80	Australian greasy.....	0 00 0 21	1 Star..... cases	12 75 14 00
do Paris, do	0 85 1 00	Durham, in bags, 1-12s and	0 00 1 00	Building Paper.		Scotch Whiskies	
English Cement, cask.....	2 25 2 35	1-6s.....	0 00 1 00	Tarred felt, per 100 lbs.....	1 70 0 00	Dewars Scotch extra spec.	9 25 9 50
Belgian do.....	1 70 1 95	Durham, 1 lb. drums.....	0 00 1 00	2 ply, Ready R'f'g., roll.....	0 80 0 00	Spl. Liqueur.....	12 25 12 50
German do.....	2 30 2 50	Ritchie's Navy Cut, 1-5 tins.	0 00 1 05	3 " " " " " " " " " " " "	1 05 0 00	Extra spl. Liqueur....	16 25 16 50
American do.....	2 25 2 50	do Smoking Mixture.	0 00 0 95	Wines, Liquors, &c.		Gin—	
Fire Bricks per 1000.....	15 00 22 00	Ritchie's Smoking Mixture,	0 00 0 95	Ale—English..... qts	2 50 2 55	De Kuyper red cases.....	0 00 11 50
Fire Clay.....	1 50 1 75	1-10s.....	0 00 0 80	" " " " " " " " " " " "	1 62 1 57	do green do.....	0 00 6 00
Rosin.....	2 75 4 50	Unique, 1-15 pkgs.....	0 00 0 66	Porter—		do violet.....	0 00 2 65
Glue—		do in pkgs., 1 lb.....	0 00 0 61	Dublin Stout... qts	2 40 2 45	do hhds.....	2 15 3 00
Domestic Broken Sheet.....	13 0 15	do in pkgs., 1/4 lb.....	0 00 0 60	do do ..pts	1 57 1 52	Irish Whisky—	
French Casks.....	0 11 0 15	O. K. Mixture, in pkgs., 15s..	0 00 0 61	Spirits Canadian—per gal.		Geo Ros & Co. 1 star, qts	9 50 0 00
do brls.....	0 00 0 14	Plug Tobaccos—		Alcohol..... 65. O. P.	4 50 4 60	do do 3 stars, qts	3 70 10 50
American White, brls.....	1 16 0 30	Ritchie's Derby Smoking,	0 00 0 63	Spirits..... 50. O. P.	4 15 4 25	John Jamieson & Co.....	9 50 11 50
Coopers' Glue.....	0 20 0 25	ing Twist, 3/4s.....	0 00 0 70	do ..25 U. P.	2 20 2 30	Angostura Bitters, per	
Golden Ochre.....	0 04 0 74	Ritchie's Old Virginia Smok-	0 00 0 70	Club Whisky..... U. P.	3 60 0 00	case of 2 doz.....	14 50 15 00
Brunswick Green.....	0 04 0 10	ing Twist, 3/4s.....	0 00 0 70	Corby's IXL Rye, qrts	8 00 8 50	Banagher Irish Whisky, qts	9 75 10 25
French Imperial Green.....	0 12 0 15	Standard, 9 1-3s, 6 lb. cads..	0 00 0 67	do do do per gal	4 00 4 25	do do do per gal	4 00 4 25
Genuine Quicksilver.....	0 90 0 95	do Thin, 9s.....	0 00 0 67	Watson's Old Irish, qts, prcs	6 75 7 75	do do do per cs.	7 75 8 75
No. 1 Furnit'e Varn'h, pr gal	0 65 0 70	W. D. & H. O. Wills.		Canadian Wines			
a do do	0 75 1 00	(E. A. Gerth, agent.)		Golden Diana, qts.....	6 00 0 00		
Brown Japan.....	0 60 0 75	Westward Ho, 1/4 lb. tins...	0 00 0 50	Fine Old Port.....	5 00 1 25		
Black Japan.....	0 50 0 75	Meridian (Cavendish 1/4 lb..	0 00 0 75	Niagara.....	5 00 1 25		
Orange Shellac, No. 1.....	1 70 1 80	Traveller.....	0 00 0 50	Burgundy.....	4 50 1 00		
do do Pure.....	1 90 2 00	Three Castles.....	0 00 0 50	Claret.....	4 50 1 00		
White do.....	0 25 2 40	Bristol Birds Eye.....	0 00 0 50	Dry Concord.....	4 50 1 00		
Putty Bulk 100 lb. brl.....	0 00 2 00	Capstan Navy Cut.....	0 00 0 50				
Paris Green in drum 1 lb pk.	18 1 0 19 1/2						
Salt.							
Liverpool per bag.....	0 40 0 45						
Canadian, in small bags....	2 10 3 00						
Canadian, Quarters.....	0 27 1 0 50						
factory Filled per bag.....	0 90 1 25						
do Quarters.....	0 27 1 0 35						

been that, at Midland, and at several other towns on the Grand Trunk Railway between Midland and Illora, Americans have been compelled to erect large sawmills, and an industry which was formerly carried on in the State of Michigan has been transferred to the Ontario side of Lake Huron.

The municipality of Midland, to induce the Furnace Company to establish its plant there, gave the company a bonus of \$50,000, and has freed it from all but nominal taxation for ten years to come. The Furnace Company is in possession of eighty acres on the north side of Midland Harbor, with a frontage of half a mile to deep water. Its furnace has a capacity of 150 tons a day, and at the time of the visit was making pig metal for shipment to Sault Ste. Marie, where it is to be used in the rails which the Clergue company is under contract to supply between now and September for the Intercolonial railway. Midland is an increasingly important station on the Grand Trunk Railway, and an excellent distributing point both by rail and water for the provinces of Ontario and Quebec.

To make this survey of the iron and steel industry in Canada complete, it should be added that the province of Quebec has one charcoal iron-making plant. It is at Radnor, near Three Rivers, the oldest iron-making centre in Upper Canada. The furnace is forty feet high, nine feet in diameter at the bosh, with a crucible five feet deep. Lake and bog ores are exclusively used at Radnor, and the Canada Iron Furnace company, which owns both the Midland and the Radnor plants, has control over 100,000 acres of ore-bearing lands and lakes in the neighborhood of the Radnor

Patent Mica Grease

SAVES 80 TO 90 PER CENT.
OVER COST OF OIL

Used on all kinds of Machinery and specially adapted for India and hot climates.

TRADE MARK.
PATENT MICA GREASE

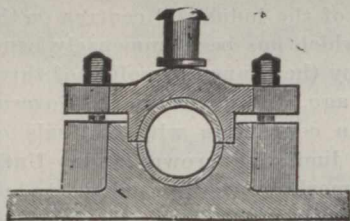

PATENT MICA PACKING
REGISTERED.

Patent Mica-Gotton Packing.
Patent Mica-Asbestos Packing.
Patent Mica-Flax Packing.
Patent Mica-India-Rubber Packing.

Will stand any degree of Heat and are Self-Lubricating. The advantages of these Packings over ordinary Packings are: They do not harden in the Glands. They are more durable. They do not Score the Rods, but put a Mica Surface on them similar in appearance to Electro Plate. They are 25 per cent. lighter than ordinary Packings. All kinds of other Packings, I. R. Valves, &c., in stock and made to order.

"MICA" BELTING SYRUP.

The Harbinger Patent Elastic Metallic Packing

Is Absolutely the Best and Cheapest.

Sole Proprietors and Manufacturers

The Mica Lubricating Company,

(Registered.)

63 King Street, SOUTH SHIELDS, England.

furnace. Except for this charcoal furnace in the province of Quebec, the manufacture of iron and steel is as yet confined to the provinces of Nova Scotia and Ontario, which are not only soon to supply all the iron and steel needed in the Dominion, but are to compete with Great Britain and the United States for the trade of the world.

BRYANT & MAY ABSORPTION.

The announcement that the well-known London firm of Bryant & May (Ltd.), manufacturers of lucifer matches, has been merged in the Liverpool Diamond Match Co., is causing British manufacturers in all trades to reflect upon their conservative meth-

Telegraphic Address:
"ALEXSON, LEEDS."

Brick, Tile and General Clay Working Machi- nery

Herbert Alexander & Co.
LIMITED.

Queen's Engineering Works

Water Lane,
LEEDS, Eng.

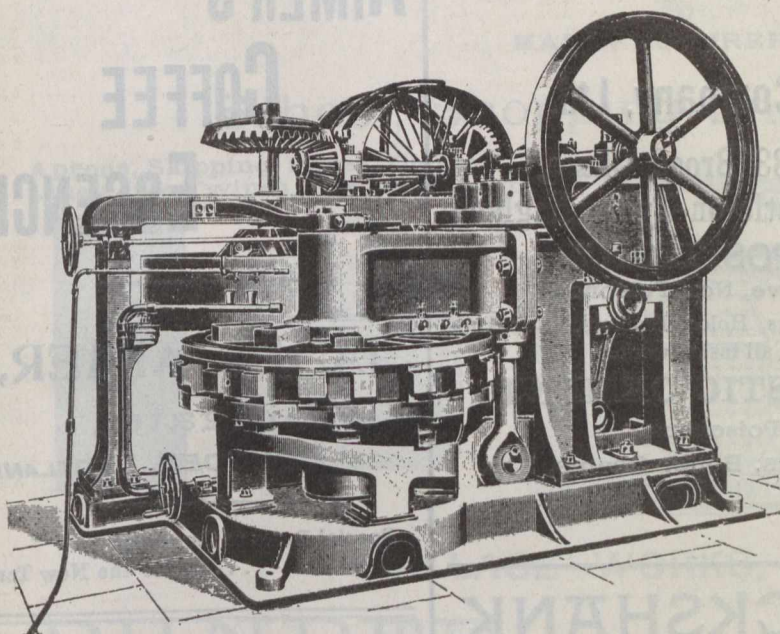

ods. The Liverpool Diamond Match Company is really an American concern. It was beating the London company by means of its labor-saving machinery, and now it has absorbed it altogether. The American plan of making matches is with a single machine to cut the wood into splints, dip them with phosphorus, and put them into boxes. Seven girls can thus turn out 1,000 gross of boxes in a day with one machine. The London firm buy their splints, dip the ends by hand, hence the disease known among their workers as phossy jaw—the splints are next cut by hand, and slowly put into boxes by hand. The American company makes boxes and prints the labels and finishes at the rate of 580 a minute. Bryant & May buy theirs ready made. To produce the same output of matches the London firm employ 1,400 workers, while the Americans can do with 700. For years the Americans have been spending money on new machinery and patents. The English were content with the old ways, and now the inevitable has happened.

TESTING ONTARIO WHEAT.

For some time the millers of Ontario have been complaining that the wheat grown in the province makes flour of an inferior quality, which can only be sold at prices below those obtained by competitors. The quality is improved by mixing Ontario and Manitoba hard, which is bought in considerable quantities for that purpose. The provincial government last fall instructed Professors Harcourt and Zavity, of the Guelph College, to thoroughly test the various sorts of Ontario wheat for their bread-making qualities, the opinion being generally expressed that the farmers were using varieties of seed yielding largely, but which were not so good for flour-making as those formerly used. Samples were taken from all over the province, ground and compared, and baked by two expert bakers of Guelph. Soil and other circumstances that might affect the quality were taken into consideration. The best fall wheats, according to the experts, are turkey red, yielding 157.6 pounds of bread for 100 pounds of flour, and

having 95 per cent. quality out of a possible 100; Scott yielded 148.2 quality, 90; Michigan Amber yielded 147.90; quality, 88.6.

RICHARD SCHOLEFIELD.

Mr. Richard Scholefield, engineer, of Burley Vale Mills, Kirkstall Road, Leeds, Eng., is a specialist in brick-making and grinding machinery. In his circular letter to the trade he says:—

"I have made considerable improvements, and shall continue to do so as occasions require. I would particularly call the attention of all interested in brick-making to the merits in my 'Eclipse-All' Stiff-Plastic Brick-making and Pressing Machine, which I venture to say is unsurpassed by any in the market. I have had repeat orders to the extent of several machines in numerous cases only recently, all of which are giving great satisfaction.

"I also would draw attention to my 'Diamond Jubilee' Semi-Plastic or Semi-Dry Brick-making and Pressing Machine, which I consider to be a de-

REGISTERED BRAND



"WAVERLEY."

Special Prices to Canadians
under the New Tariff. . . .

Waverley Iron & Steel Co.,

COATBRIDGE, SCOTLAND, Manufacturers of

HIGHEST CLASS SCOTCH IRON & FINEST INGOT STEEL.

IN BARS, ANGLES, TEES AND HOOPS.

Iron and Steel tested with "Buckton's" latest machine, and certified accordingly, if required, before leaving the Works.

Special attention given to the quality for Horse-Shoeing, Rivet, and all other purposes.

Shipping Ports:—GLASGOW, GREENOCK, LEITH, GRANGEMOUTH.

ODIC COMPOSITIONS

MANUFACTURERS :

Odic Plastic Composition Company, Ltd.

33 Broad Chare,

Newcastle-on-Tyne, England.

Tel. Add.: "Odic," Newcastle-on-Tyne.



"ODIC COMPOSITION"

Non-Explosive, Non-Poisonous.

For Steel or Iron Decks, Holds, Bunkers, Tank Tops, Inside of Tanks, and all inside work.

"ODIC" PLASTIC CEMENT

Non-Poisonous.

For Steam Joints, Boller Seams, Etc.

AGENTS WANTED IN CANADA.

R. D. & C. J. CRUICKSHANK,

BISCUIT MANUFACTURERS,

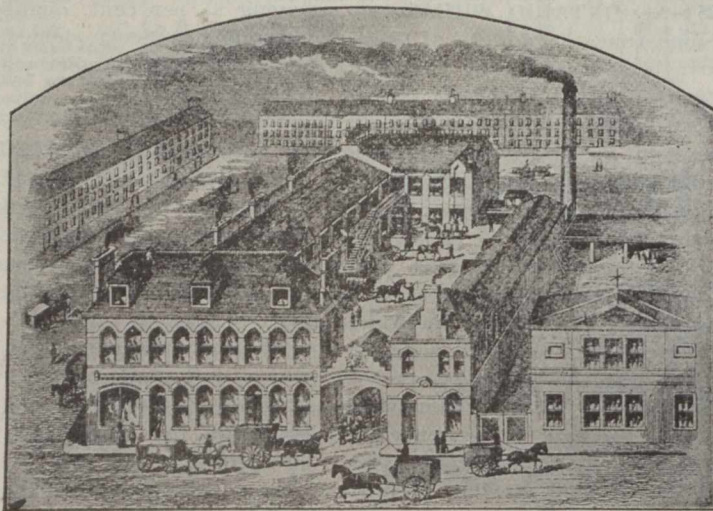

[ESTABLISHED 1848.]

[ESTABLISHED 1848.]

Lambhill Street, Paisley Road,

GLASGOW. - - SCOTLAND.

Hudson & Griffith, FLEECE STREET,
Keighley, Yorks, England.

Do you want a Treadle Lathe? Ours has more Improvements than any other.

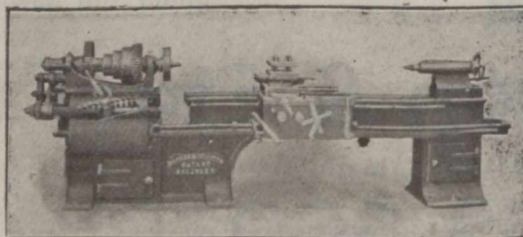

Note that all our Lathes are fitted with: "Ball Trust," "Hollow Spindle," "Graduated Slide Rest," "Tailstock for Taper-Turning," "Highest-class Workmanship," "Best Material." Our Patent Treble Gearing stands alone; three times the power with less work. Write for Illustrations and be convinced.

Special Terms to Canadians under the New Tariff.

USE

AIMER'S COFFEE ESSENCE.

Sole Manufacturer . . .

JAMES AIMER,

Cowgate.

DUNDEE, SCOTLAND.

Special Rates to Canadians

. . . Under the New Tariff

cided advance in this class of machinery, and can confidently recommend the same. A number of firms have each several of them working.

"My Wire cuts and pug mill machinery are well worthy of notice, they are well dsigned, strong, and durable, and are made in various sizes, according to output required.

"In my steam and hand presses I feel satisfied that they are equal to any extant. The toggle press is replete with all improvements requisite for the making of a good faced brick. These remarks also apply to my improved upright press. Horizontal engines are made in several sizes, and are up-to-date and reliable.

"For the convenience of foreign and colonial customers generally, I have added a new feature in my catalogue, viz.: Plans of my combinations of machines for dealing with different kinds of materials, and which will, no doubt, be of great assistance in ordering.

"If you are contemplating the erection of brick-making machinery, I should be pleased to arrange for my representatives to call on you, and advise the best machinery to suit your purpose. I have every confidence that I shall be able to give you satisfactory results.

"I am prepared to advise you upon the latest system of plant, buildings, kilns, drying sheds, &c., also to value existing brick works. In conclusion, I beg to say that any orders placed with me will have my careful and personal attention."

Specialties especially suited for the Colonies are Scholefield's patent semi-dry or semi-plastic brick-making plant, in which are embodied Scholefield's arrangements for semi-dry or semi-plastic brick-making plant, for treating bind shale, marls, &c., as used for building and fire brick making. They consist of the following machinery:— 9-ft. perforated grinding pan, elevators, single horizontal mixer, "Dia-

ALEX. B. CRICHTON & Co.

MANUFACTURERS OF

School, Shopping and Market Bags,

Aprons, Skipping Ropes, Clothes Lines, Jute Twines, Hearth Rugs,

Door Mats, Art Squares, Matting, Jute Carpets, &c.

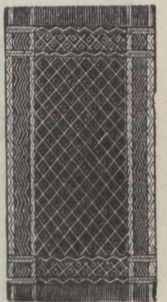

WALLACE WORKS, (Den's Road)

DUNDEE, - SCOTLAND.

Morison's Radial Evaporator

Fitted in upwards of 2,000 STEAMSHIPS.

Minimum of Labour and Attention required at sea.

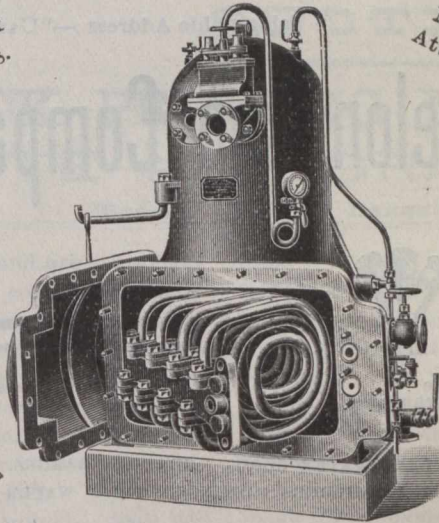

General Handiness and Facilities for cleaning UNSURPASSED.

Strong in construction, Simple in design and Efficient in working.

Richardsons, Westgarth & Co., Ltd.,
HARTLEPOOL, ENGLAND

mond Jubilee" brick making and pressing machine. Capacity: 10,000 to 12,000 per day. Extras—Driving belts and driving drums.

A companion to this is Scholefield's patent stiff-plastic brick-making plant, which embodies Scholefield's arrangements for making superior engineering bricks from refractory marls and shales, bind, "Blaiz," and pit refuse, &c., ready to set direct in kiln without any previous drying. It consists of 8-ft. or 9-ft. perforated grinding mill, elevators single horizontal mixer, patent "Eclipse-All" stiff-plastic brick-making and pressing machine. Capacity: 10,000 to 12,000 per day. Extras—Driving belts and driving drums.

ROSLING, APPLEBY & FYNN.

In connection with the manufacture of modern improved power motors this firm is well known throughout

A. Earnshaw & Sons, Ltd.,

MAKERS OF

Lathes up to 40 inch centres
Railway Wheel Lathes
Planing Machines
Slotting Machines
Drilling Machines
Plate Bending Machines
Plate Edge Planing
Machines

and
Milling Machines

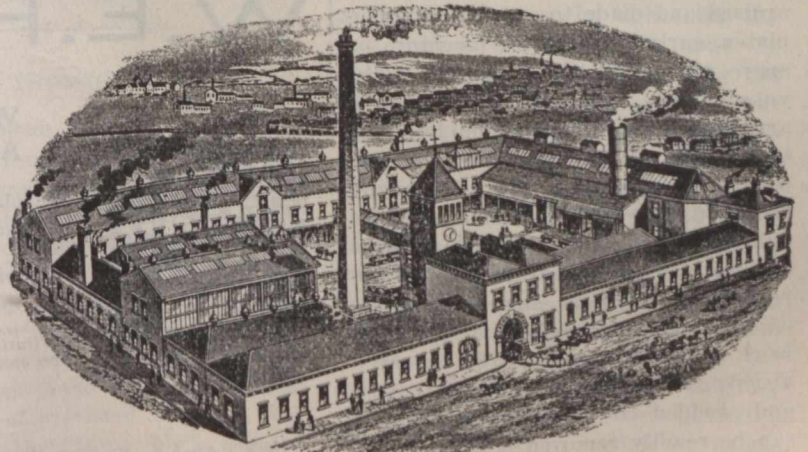

Crown Works, HALIFAX, ENG.

Contractors to His Majesty's Government--War Department and Admiralty.

Jos. Steel & Sons

MAKERS OF

Spiral = = Springs =

For all Classes of Machinery
& Engineering Work.

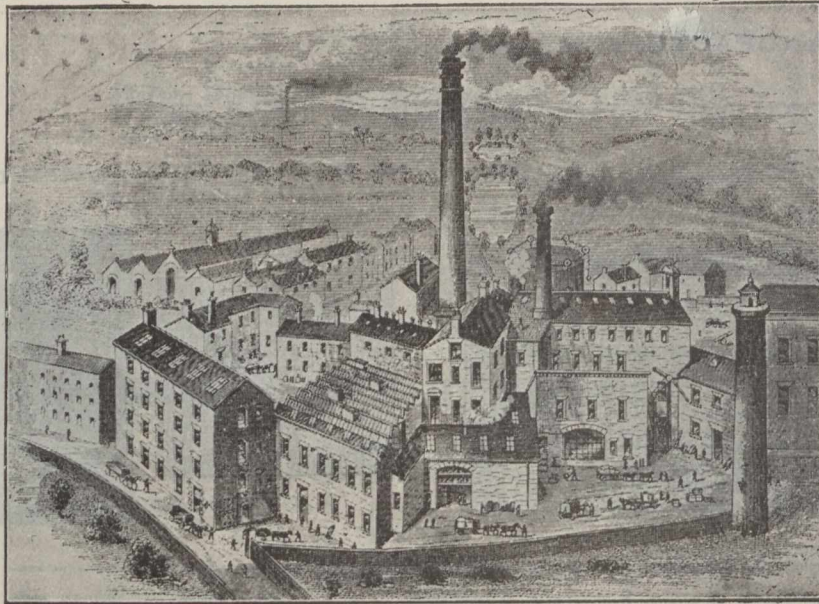

Harden Spring Yorks, near BINGLEY, Yorkshire, Eng.

Special terms to Canadlans under the new Preferential Tariff Telegraphic Address, "STEEL, BINGLEY."

England, and desires to extend the field by introducing to Canadians the merits of their "Twentieth Century Continuous Current Protected Motors." The following points are claimed by the above makers to be worth the serious consideration of intending purchasers:

These motors are constructed on the experience gained by ten years' manufacturing and experimenting, and combine the best English practice with some desirable features introduced from American and Continental designs, in addition to the valuable improvements patented by Mr. A. V. Fynn. The makers, consequently, may without exaggeration claim for them merits which make them superior to any others now on the market.—Owing to the entire absence of sparking and the efficient design these motors will run for long periods with a minimum of attention and a small temperature rise, the output being limited by heating and not by sparking; for short runs or intermittent work the loads given may be largely exceeded.—The firm carry a large stock of motors, and parts, and as these are all standardised and made to gauges and templates, early delivery for machines or spare parts can be guaranteed.—The yoke of soft annealed cast iron is so arranged that it forms a complete protection for the field magnets, armature and commutator, avoiding any risk of danger to these parts, and, as will be seen from the print, gives the machine a substantial and neat appearance.—The pole pieces are made of steel, and are specially designed to work in connection with the patented armature winding; they are bolted and studded to the yoke frame, and can be readily removed if required.—The field energizing coils are equal to

Telegraphic Address :—"CAMELON," FALKIRK.

The Camelon Iron Company, Ltd.,



Single branch pieces. Double branch pieces.

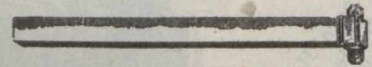

Square Rain-water Pipe.

HOT WATER GOODS. RAIN WATER GOODS. GRATES. RANGES. HORTICULTURAL, AGRICULTURAL & BUILDERS' CASTINGS. GAS & WATER PIPES, &c.

GENERAL IRONFOUNDERS,
Camelon Iron Works, - FALKIRK, SCOTLAND.

THE CAMELON CLOSE FIRE KITCHENERS.

W.E. Foggin & Co.,

No. 9 by 9 of 17 g.



WIRE WORKERS
AND WEAVERS,

Manufacturers of all kinds of SCREENS
for Mining and other purposes . . .

RIDDLES, SIEVES AND
GENERAL WIRE WORK.

Illustrated Catalogues and estimates
free on application.

ESTABLISHED 1830.

No. 4 by 4 of 11 g.

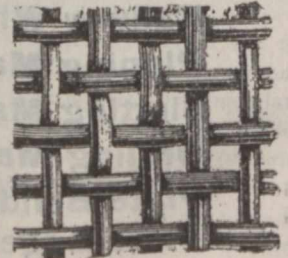

14 HIGH BRIDGE, Newcastle-on-Tyne, Eng.

D. J. MACDONALD, → M. I. ←
Mech. E.

Maker of Sack Cutting, Hemming, Sewing and Printing Machines,

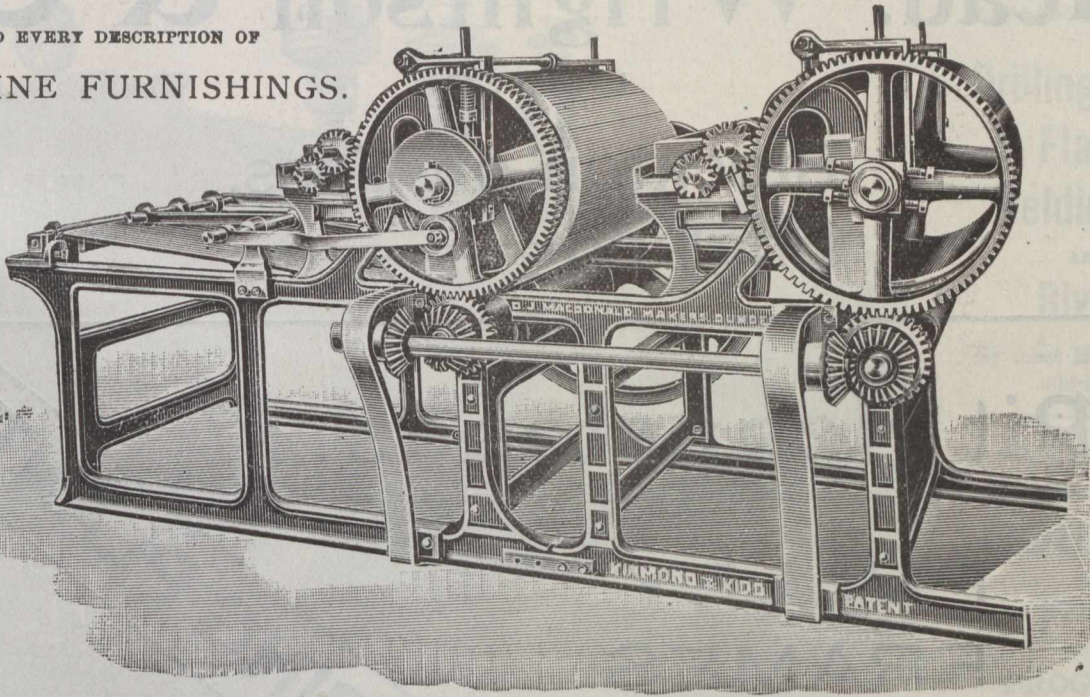
AND EVERY DESCRIPTION OF
MACHINE FURNISHINGS.South St. Roque's Works, DUNDEE,
SCOTLAND.**SACK PRINTING MACHINES, THE FINEST
MACHINE MADE**
For JUTE and GRAIN BAG PRINTING.

Special Prices to Canadians under the New Tariff.

the poles in number, and are constructed of the best high conductivity copper wire, wound on very stout insulating formers tested to withstand 5,000 volts pressure. The connections are made with copper strip arranged on an improved principle, eliminating the danger of break-down through fracture or short circuiting.—The armature is built up of notched discs assembled and keyed on to a shaft of best mild steel of great strength; the plates are insulated from one another by thin hemp paper, and are held in position by stout gun metal end plates with projections to hold the plate teeth securely in place. The armatures are carefully balanced and baked before winding, and the slots are carefully insulated from end to end.—They are wound with high conductivity treble cotton covered copper wire, the wire being arranged symmetrically in the slots in accordance with our patents. The whole armature after winding is thoroughly baked at 200 deg. Fahr., to remove all traces of damp, and well varnished.—The commutator is built of hard copper sections of high conductivity, insulated with mica and held between micanite end rings securely held on a gun metal sleeve.—The brush gear is of our radial carbon type, with high grade brushes, special precaution being taken to avoid the loss through bad contact so often found in the or-

inary designs.—The terminals are inside the yoke, the four insulated wires from the armature and the field coils are brought out through stuffing boxes, so that they can be readily joined up and arranged for the armature to run in whichever direction is required without any alteration to the machine itself.—The bearings are made of phosphor bronze or lined with white metal and are self-centering, very heavy and stiff in construction, and arranged with two rings each for automatic lubrication.—The pulleys are of cast iron, carefully machined and balanced.—Write for price list and special terms to Canadians under new tariff, to Messrs. Rosling, Appleby & Fynn, Limited, Trafalgar Works, Bradford, Yorkshire, England.

WM. THOMSON & CO.,

Wm. Thomson & Co., engineers of 57 Smith street, Kinning Park, Glasgow, are manufacturers of the Thomson internal expanding cutter for boiler tubes, internal ferrule extractors, suspended lever weighing machines, ratchet handles and ratchet braces, screw keys and box keys, emery grinders of every description, steering gear—hand and steam, travelling cranes—overhead; chains, &c., &c., and of the "Invincible" corking machine. Their patent hoist is spe-

cially adapted for warehousemen, millers, brewers, butchers, and all other classes requiring great speed for lifting and lowering loads of from 5 to 20 cwt. It can be used as a self-sustaining block, or by merely applying the hand-chain (and without any special chain or cord), for lowering by brake power. The Thomson patent internal tube cutter is specially made for cutting boiler tubes, either at the ends or inside of the tube plate, when boilers require to be re-tubed. A tube of medium size can be cut in a few minutes with perfect ease.

Thomson's patent ferrule extractor, for withdrawing ferrules, valve seats, &c., consists of a screw having a cone formed at one end, a hollow cylinder fitted with a number of claws placed around the cone, so by tightening the nut against the bridge the cone is drawn backward, thus expanding the claws so as to catch against the inner edge of the ferrule, and by continuing to tighten the nut the ferrule is drawn out.

Thomson's patent suspended lever weighing machines are capable of weighing the smallest weights to 100 tons and upwards. These machines are made to indicate with common weights, and they are about half the weight of the hydrostatic weighing machine, and about one-eighth the weight of the compound lever weighing machine. Each machine above

Head, Wrightson & Co.

LIMITED.

Stockton-on-Tees,
England

... Pit Heapsteads ...

PULLEY
FRAMES

AND

PULLEYS.



SHAKING
SCREENS,

Travelling

AND

Picking Belts.

COAL SCREENING & CLEARING PLANTS.
TIPPLERS, Coal Shipping Appliances.
ELEVATORS,

thirty tons made by special agreement. Weights required to weigh the different sizes of machines, 20 lbs. to the ton.

Another specialty of the firm is Thomson's patent "Invincible" bottle corking machine. The strongest, cheapest, simplest, and best machine made. To suit, from the shortest to the longest pint bottles, and from the shortest to the longest quart bottles. With self-raising, self-locking adjusting apparatus, with cork crushing motion. No chipping of corks. No breaking of bottles. Bottles filled up full to the lip can be corked with perfect ease and safety without the use of a needle or wire. Each machine supplied with the necessary receptacle for spilt liquors, also pan for holding corks. Used and highly re-

commended by the principal wine and spirit merchants throughout the Kingdom.

WILLIAM JOHNSTON & SONS, LTD.,
Millings and Brick Engineers,
Castleton Foundry, Armley, Leeds,
England.

Manufacturers of Plastic Brickmaking Machinery. Among the specialties of this well-known firm is the No. 1A Pugmill Brickmaking Machine. — This machine is of very massive construction and is capable of a production of 40,000 bricks and upwards per day of 10 hours. Similar to their other machines of this type, it can be supplied either with or without crushing rollers, and hoist. The shafts are all of steel, bearings of gun metal, and the

thrust is specially designed and constructed to meet the requirements of the very large output of which this machine is capable. The knives and worm are easily changed, and notwithstanding the large capacity of this machine the wear and tear is extremely small. The crushing rollers are easily adjusted and are made of a special mixture of hard tough metals. The cutting table used in connection with this machine may be a double hand cutter or a patent automatic table of which they are the sole makers. Power required for driving—from 45 brake H.P., but this varies according to the nature of the clay which is being operated upon. Weight: 17 tons, approximately. Shipping measurement: 775 cubic feet, approximately. Design subject to alteration without notice.

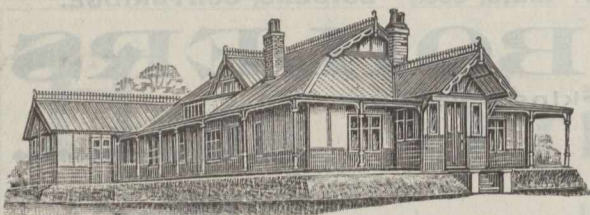

BUNGAL OW.

**THE ALNWICK FOUNDRY
& ENGINEERING CO.,**
Alnwick, England,

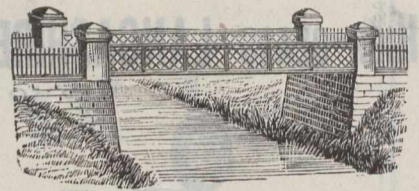

MANUFACTURERS OF
IRON BUILDINGS,
Churches, Schools,
HOSPITALS, BARNs,
WAREHOUSES,
HEAPSTEADS.

Huts, Hay Sheds, Farm Buildings.

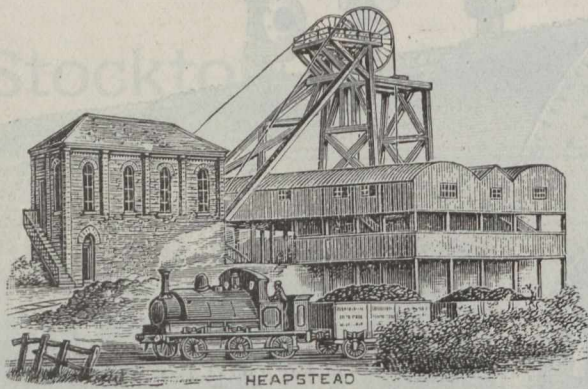

HEAPSTEAD

Wrought Iron
Constructional Work.
Steel Principals,
GIRDER..
BRIDGES,
CAGES,
FENCING, &c.
COLUMNS.

Special Prices to Canadians under the New Tariff

have the meaning of the words "not otherwise provided for."

(Continued from Page 440.)

Collections of postage stamps, free ;
Colleges, articles for, see Philosophical Instruments; Collodion, for photographers' use, 20 p.c.; Colchicum seed, see Seeds; Colcothar, see item Oxides; Cologne, color in pulp, 25 p.c.; Cologne water, and perfumed spirits, in bottles, flasks, or other packages, not weighing more than four ounces, 50 p.c.; Cologne water, and perfumed spirits, in bottles, flasks, or packages, weighing more than four ounces each, see Spirits, \$2.40 per proof gal., and 40 p.c.; Colored glass, in sheets, plain, see Glass; Colored glazed paper, 35 p.c.; Colours and paints, pulped or ground in oil, N.E.S., see Paints, 25 p.c.; Colouring, butter colouring, if armatta, free ; Colouring, non-alcoholic, N.E.S., 20 p.c.; Colouring, containing alcohol, to pay as spirits, see Spirits; Colours, dry, not elsewhere specified, 20 p.c.; Colours, ground in spirits, and all spirit varnishes and lacquers, \$1.12½ per gal.; Coloured sand, 20

WARNER & CO., LIMITED,
Makers of... **SPECIAL PIG IRONS.**

Brand "WARNER C.S.R."

Gives the **Highest Transverse and Tensile Tests** of any Pig Iron in the market. Suitable for Steam and Hydraulic Cylinders, Chilled Rolls, and all High Class Engineering Castings, also for Best Puddled Bars.

Brands "H.W." "O.K." "C.P."

For Malleable Castings The brand "C.P." is the **Purest English Pig Iron for Malleable Castings** in the market. These three brands are all cast in **Small Pigs**.

Brand "ANGLO-SWEDISH C.P." (in slabs)

This is one of the **Purest Irons** in the market, and is suitable for mixing with other Irons to **improve quality of Castings**. It is also suitable for **Steel Making**.

PIG IRON MADE TO ANY ANALYSIS.

Cargo Fleet, Middlesbrough-on-Tees, - England.

p.c.; Colza oil, see Oils; Combs, painters' graining combs, 30 p.c.; Combs, for dress and toilet, including mane combs, all kinds, 35 p.c.; Combs, curry combs, as saddlers' hardware, 30 p.c.; Comforters, see

Bed Comforters; Commercial blank forms, printed or lithographed, 35 p.c.; Communion plate, when imported for the use of churches, comprising flagons, chalices, patens, cruets, and alms dishes, free; Common



TRADE MARK.

Unshrinkable
Cycling . . .
Skirts . . .

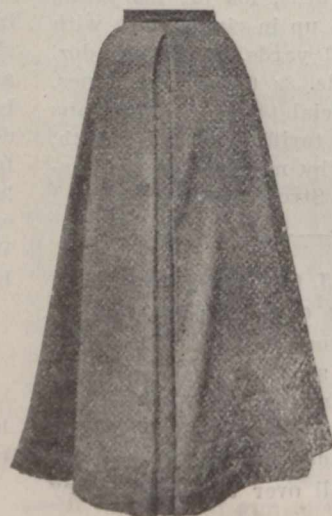

"THE ERA."

The "ERA."
The "ARIEL."
The "ECLIPSE."

Simple. Perfect Fitting. Graceful.

NO COMPLICATIONS.

These Skirts are made from **BARKER & MOODY'S** Celebrated **Unshrinkable Cycling Costume Cloths**, which are manufactured expressly for this purpose.

BARKER & MOODY, Kirkstall Road,
LEEDS, Eng.

Special rates to Canadians under the New Tariff.

Telegraphic Address: "PURIFIER, BATLEY."

ESTABLISHED 1866

JOHN ILLINGWORTH & SONS,

Ridings Mills, WHITELEE,
(And at Garfield Mills).

BATLEY, ENGLAND.

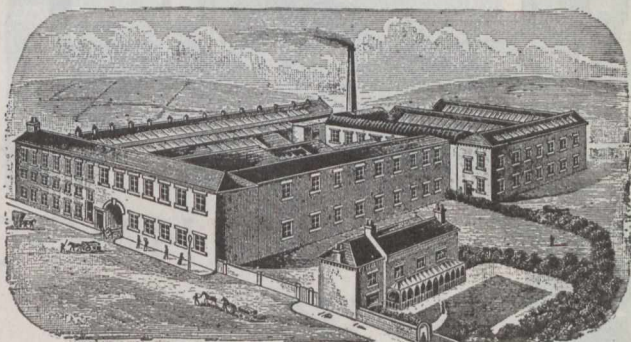

RIDINGS MILLS.

Patentees and Sole Makers of the
CELEBRATED PURIFIED

Flocks and Wools,

Large Stocks of all Descriptions of

Drummed Wools & Ruggings

Manufacturers of
all kinds of . . .

FOR COLLAR MAKERS
AND BROWN SADDLERS.

HORSE CLOTHING

Kersey, Rugging, Tiltings, India and Check Serge. Prince's Check, Linen, Hemp, Navy Canvas, Combination and Jute Sheets of every variety.

BEST MAKE. SUPERIOR CUT. LOWEST PRICES.

Waterproof Gig Aprons, Box Cloths, Macintoshes and Oil Cloth Loin Covers. Body Rollers, Surcingles, Knee Caps, Fetlock Boots, Speedy Cut Boots, Saddle Girths, Body Belts, Athletic Belts and Braces. Webs of every description, Collar Checks, Linings, Serges and Collar Cloths. Heads and Reins, Martingales, Breastplates, Driving Reins, Cruppers and Stirrup Leathers made on the premises, for Home Trade and Export.

NONE BUT THE TRADE SUPPLIED. PRICES ON APPLICATION.

Wrot.-Iron Pulleys.

Bright Steel Shafting.

Lists sent Post Free
on Application.

Telegrams:
"Crowther, Cleckheaton."
A B C Code used.

Telephone
43.



HENRY CROWTHER
MAKER OF WROUGHT IRON PULLEYS,
CLECKHEATON, YORKS.

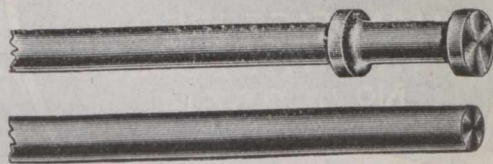

HENRY CROWTHER,

Rolling Mills,
Cleckheaton,
YORKS, ENGLAND.

Special Terms to Canadians under the New Tariff.

soap, or laundry soap, not perfumed, 1c per lb.; Communion wafers, 20 p.c.; Compasses for ships, free; Compasses, N. E. S., 25 p.c.; Composition metal for the manufacture of jewellery, see Metal; Composition nails, spikes, and sheathing nails, 15 p.c.; Composition fuel, in blocks, 20 p.c.; Composition, Adams, etc., see Adams composition; Composition ornaments or terra cotta, 35 p.c.; Composition polish, &c., 25 p.c.; Compositions, medicinal, see Medicines; Compound, Founders' Core Compound, 20 p.c.; Compressed Yeast cakes, see Yeast, &c.; Compressors for refrigerating plants, 25 p.c.; Concentrated lye, 20 p.c.; Condensed coffee, see Coffee; Concentrated dongola (leather dye), 20 p.c.; Condensed coffee, with milk, 30 p.c.; Condensed milk (weight of the package to be included in the weight for duty), 3¼ cents per lb.; Condensers for refrigerating plants, 30 p.c.; Confectionery, sugar candy and popcorn, ½ cent per lb. and 35 p.c.; Control clocks, known as watchmen's clocks, 25 p.c.; Copper-

R. & S. BAXTER

OFFICE ADDRESS:
81 Murrigate, DUNDEE, SCOTLAND.

TEL. ADDRESS:
FARINA, DUNDEE

WORKS:
Commercial Court.

MICA

IMPORTERS AND MANUFACTURERS OF MICA
For All Purposes.

Large Stocks at our Stores in Dundee, of Ruby, Clear and Clouded. Regular shipments received direct from the mines.

CONTRACTORS TO HIS MAJESTY'S GOVERNMENT.

ed iron or steel wire, N.E.S., see Wire; Copper, bars and rods, in coil or otherwise, unmanufactured, in lengths not less than 6 ft., free; Copper bars, rods and sheets, N.E.S., 30 p.c.; Copper nails, 30 p.c.; Copper rollers for use in calico printing, when imported by calico printers for use in their factories for printing calicos and for no other purposes (such rollers not being manufactured in Canada), free; Copper rivets, 30 p.c.; Copper in bolts, unmanufactured, free; Copper burrs, 30 p.c.; Copper, old and scrap, or in blocks, free; Copper tubing, in lengths of not less than 6 feet, not polished, bent or otherwise manufactured, free; Copper tubing, N.E.S., 30 p.c.; Copper tubing, brazen, 30 p.c.; Copper in sheets or subdivisions, shaped or otherwise manufactured, 30 p.c.; Copper sheets, plates or ingots planished or coated, 30 p.c.; Copper sheets, strips or plates not planished, polished or coated, free; Copper ingots or pigs, free; Copper wire, see item Wire; Copper baths, N.E.S., 30 p.c.; Copper shells, etc., see Stereotypes, etc.; Copper bath tubs, fitted up in frame or stand of wood, 30 p.c.; Copper, all other manufactures of, N.E.S., 30 p.c.; Copper plates for doors, finished, builders' hardware, 30 p.c.; Copper, sulphate of (blue vitriol), free; Copper, subacetate of, dry or verdigris, free; Copper, precipitate of, crude, free; Copper, black oxide of, etc., see Platinum; Copperas, sulphate of iron, free; Copying books, 35 p.c.; Copying presses, as office furniture, 30 p.c.; Copying pencils, 25 p.c.; Corals, see Precious Stones; Cords and tassels of silk or any other material, N.E.S., 35 p.c.; Cords, yarn for the manufacture of, see Yarns; Cordage, of all kinds, N.E.S., see Twines; Cordials, medicinal, see Medicines; Cordials other, see Spirits; Corduroy, colored cotton to be rated as cotton fabrics; Coriander seed, see Seeds; Corms, see Florist Stock; Corn harvesters, 20 p.c.; Corn, "dried or evaporated," 20 p.c.; Corn syrup, see Syrups; Corn, Indian, see Indian Corn; Corn huskers and shellers, 25 p.c.; Corn meal, including the duty on the barrel, 25 cents per brl.; Corn flour, when found to contain all the properties of the corn or corn meal, less the bran and other parts removable by boiling only, and not capable of being used as starch without further change, 20 p.c.; Corn meal, when damaged by water in transitu (on appraised value), 20

GEORGE SWIFT,

Claremont Iron Works, HALIFAX, ENGLAND.

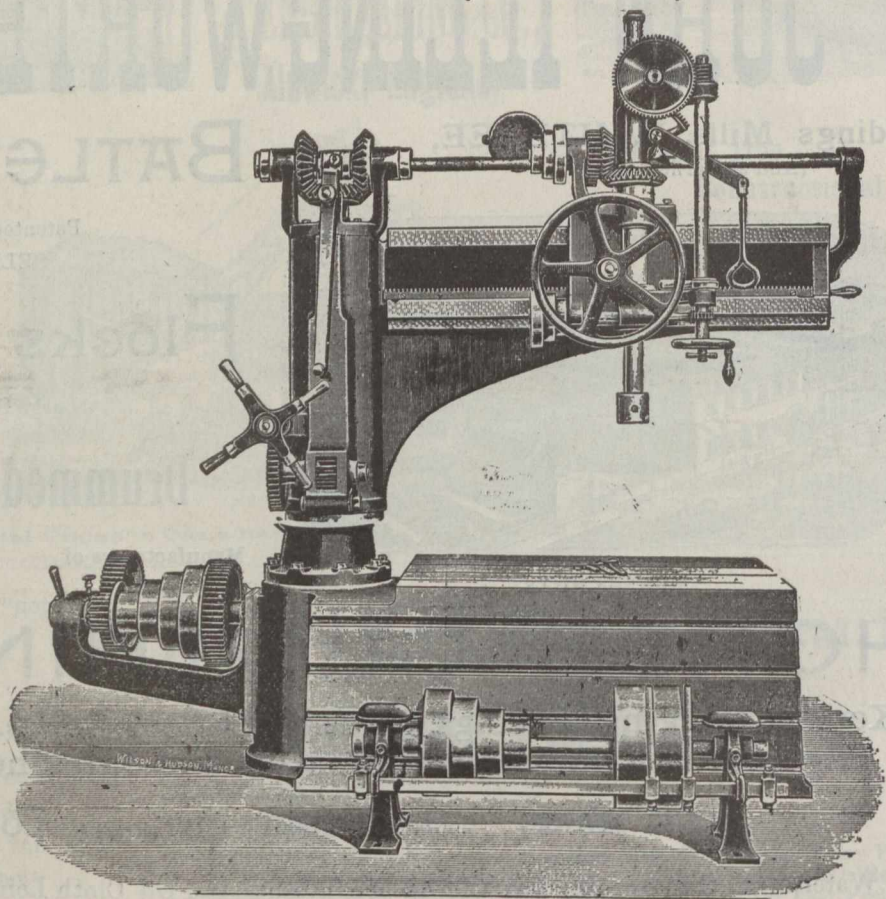

IMPROVED 5-FT. RADIAL DRILLING AND TAPPING MACHINE.

Machine Tools of every Description. Drilling Machines — A — Speciality.

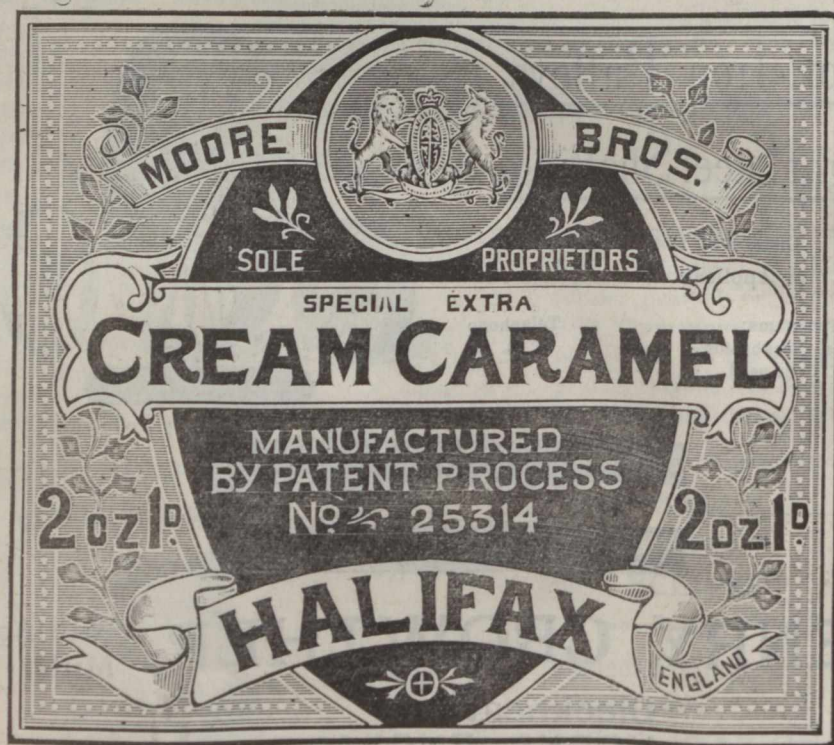

JOHN STONES,

Shiffnall Mill,

BOLTON, Eng.

Dress and Blouse Materials, Bleached and Unbleached Cottons, Prints, &c.

Also handles a Big Line of Goods, slightly damaged in process. These are valuable to Departmental Stores, under the New Canadian Tariff.

COCHRAN VERTICAL MULTITUBULAR BOILERS

For Every Purpose.
Our Speciality—IMMEDIATE DELIVERY FROM STOCK.

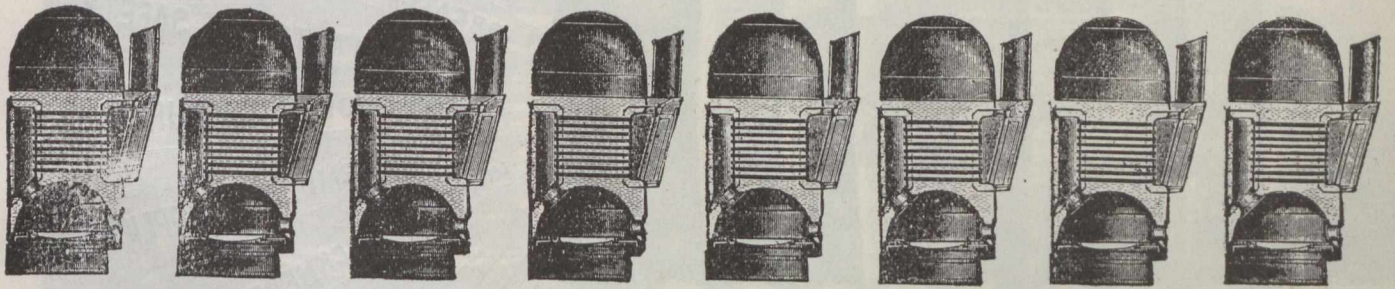

COCHRAN & CO., ANNAN, LIMITED, ANNAN, SCOTLAND.

Special Prices to Canadians under the new Canadian Tariff.

Contractors to
THE ADMIRALTY
WAR OFFICE
ETC

YACHT FITTINGS A SPECIALITY

JOSEPH W^M RUSSELL & CO.

PROGRESSIVE WORKS
CHARLES ST
ST. ROLLOX
GLASGOW SCOTLAND

BRASSFOUNDERS
& FINISHERS

PLUMBERS
FITTINGS
SANITARY
OF WORK
ALL KINDS

TELEGRAPHIC ADDRESS
RUSTLE—GLASGOW

ANDREW GILLESPIE & SONS, ENGINEERS

PATENT TRAVELLING CHAIN OVEN Complete with Conical Driving and Striking Gear.

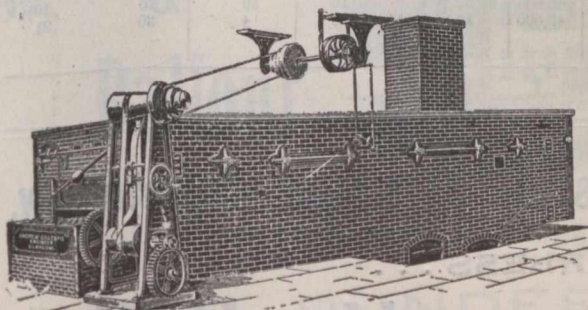

THIS is the best class of Oven for baking all kinds of fancy, hard and soft biscuits. A prepared channel, consisting of iron guides or rails, serves to conduct the four endless chains which travel through a long, heated chamber; the rails are borne on cast-iron bearers, while the cross-bearers are connected with the principal framework of the Oven.

The pans and trays are laid out upon these chains at the feeding end, the biscuits being placed upon them as they arrive from the cutting-machine are baked when they reach the other end. The time required for this operation varies from three to twenty minutes, according to the class of biscuits required. The speed of the chains may be regulated with the greatest accuracy, as by simply turning a hand-wheel connected with a specially-designed conical driving gear, the motion of the whole can easily be altered, even to the fraction of a minute.

The heat from the furnaces is transmitted to the baking chamber through a most perfect system of flues; these are covered with specially-prepared fire-clay tiles. Any change of temperature may be obtained in the chamber by means of suitable dampers placed at various points. The whole of the ironwork is built in with brickwork; the fires or furnaces are situated under the main chamber of the Oven, below the floor line, and are fitted with ordinary furnace and register doors; the smoke and flame from the furnaces are completely excluded from the interior of the Oven by the flues, and do not come in contact with the biscuits; ordinary small coal may be used. This Oven is made in four regular sizes, but special sizes are made to order, if required.

The following Prices include all the ironwork, which is very heavy and substantial: steel sheets in the cover flues, conical driving and striking gear, countershaft with hangers, fast and loose pulleys, cone pulleys, belt-shifting attachments, best double-link steel chain, best quality fire-clay tiles, &c., all complete. Furnaces and bars for hand stoking.

No.	Length over all	Width of Baking Space.		PRICE.	Extreme Measurements.			Approximate Weight including Tiles.	Telegraphic Code Words.
		Ft.	Ins.		Ft.	Ins.	Ft. Ins.		
1	24	4	9		24 long,	10 3 wide,	8 6 high.	Cwt. 204	Alliance Allied Alligate Allow
2	30	4	9		30 "	10 3 "	8 6 "	232	
3	36	4	9		36 "	10 3 "	8 6 "	240	
4	47	4	9		40 "	10 3 "	8 6 "	252	
	44	4	9						
	50	4	9						

MORISON SUSPENSION FURNACES.

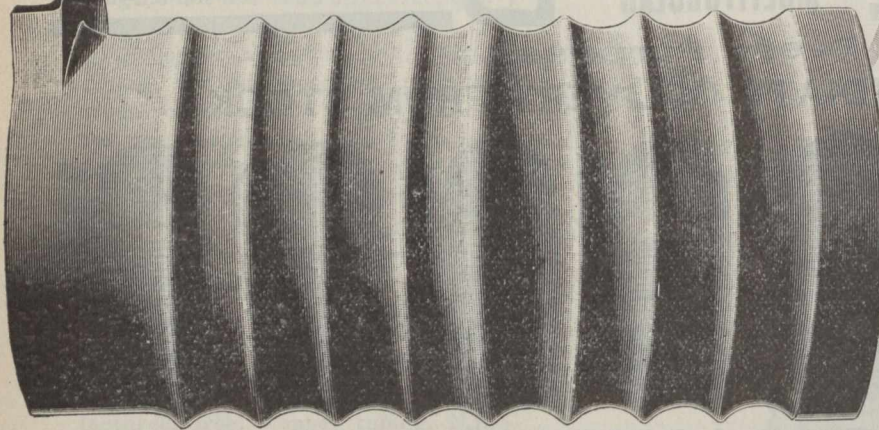

EASILY SCALED.
 GREATEST EVAPORATIVE EFFICIENCY.
 HIGHEST FACTOR OF SAFETY.
 MADE UNDER ALL SURVEYS.
 LATEST FORMULÆ ON APPLICATION.
 UNIFORM THICKNESS.

FLANGED COMPLETE BY HYDRAULIC MACHINERY AT ONE HEAT.

The Leeds Forge Company, Ltd. LEEDS, ENG.

These Furnaces are made from special quality of Open-Hearth Acid Steel made at our Works, from the best selected brands of Swedish and Cumberland Hematites.

The United States Survey allow a Constant of 15,000 for Morison Suspension Furnaces and only 14,000 for all other corrugated types of furnace.

Agent: Mr. GEORGE HOLLAND, 12 Seymour Avenue, Montreal, P.Q.

p.c.; Corn, pop corn, 1/2 cent per lb. and 35 p.c.; Corn, canned, see Vegetables; Corn cob pipes, tobacco, 35 p.c.; Cornstarch flour, see Starch; Cornelians, see Precious Stones; Cork pullers, to pay according to material; Cork pressers, pay according to material; Cork buoys, covered with cotton duck and bound with rope, 35 p.c.; Corks, and other manufactures of cork-wood or cork bark, N.E.S., 20 p.c.; Cork soles, finished as part of boots, etc., 25 p.c.; Corkwood or cork bark, unmanufactured, free; Corkscrews, according to material; Cork drawers, according to material; Cork matting and carpet, see Oil Cloth; Corn planters, see Agricultural Implements; Corrugated iron flues, see Tubing; Cornice poles and pole ends, brass, 30 p.c.; Cornwall or china stone, ground or unground, free; Corsets, cotton, silk or linen, 35 p.c.; Corsets, steel for, see Corset Steel in Steel.

(To be Continued.)

STOCKS AND BONDS—INSURANCE COMPANIES—CANADIAN.—Montreal Quotations Aug. 5, 1901.

NAME OF COMPANY.	No. Shares.	Last Dividend per year.	Share par value.	Amount paid per Share.	Canada quotations per ct.
British American Fire and Marine....	15,000	3 1/2-6mos.	350	\$50	107 1/2
Canada Life.....	2,500	5-6mos.	400	50
Confederation Life.....	10,000	7 1/2 6mos.	100	10
Western Assurance.....	25,000	5-6mos.	40	20	113 1/2
Guarante. Co. of North America.....	13,372	6	50	50

BRITISH AND FOREIGN.—Quotations on the London Market, July 27, 1901. Market value p. p'd up sh.

Alliance Assur.....	250,000	8s. p.s.	20	2 1-5	9 1/2	9 3/4
Atlas.....	24,000	24 p.s.	50	6	24 1/2	22 1/2
British and Foreign Marine.....	67,000	25	20	4	17 1/2	18 1/2
Caledonian.....	21,500	12s. p.s.	25	5	5	36 7-1
Commercial U. Fire, Life and Marine.	50,000	27 1/2	50	5	45 1/2	46 1/2
Guardian Fire and Life.....	200,000	9	10	5	8 1/2	9 1/2
Imperial Fire.....	60,000	25	20	5	22 1/2	23 1/2
Lancashire Fire.....	135,493	5	20	2	3 1/2	3 3/4
Lion Fire.....	100,000	3	20	1 1/2	3 1/2	3 1/2
London and Lancashire Fire.....	85,100	22	25	2 1/2	17	18
London Assurance Corporation.....	35,862	20	25	12 1/2	49	50
London & Lancashire Life.....	10,000	10	10	2	8	8 1/2
Liv. & Lon. & Globe Fire and Life...	391,752	90	St.	2	44	45
Northern Fire and Life.....	30,000	*22 1/2	100	10	73	75
North Brit. & Merc. Fire and Life...	110,000	30s. p.s.	25	6 1/2	36 1/2	37 1/2
Norwich Union Fire.....	11,000	*33 1/2	100	12	110	113
Phoenix Fire.....	53,776	85	50	5	53 1/2	53 1/2
Royal Insurance Fire and Life.....	125,234	58 1/2	20	4 1/2	47 1/2	48 1/2
Sun Fire.....	240,000	8s 6d p.s.	10	10	10	10 1/2
Union.....	45,000	19 p.s.	10	4	20	21

*Excluding periodical cash bonus.

Polishing--A Pleasure.



Will not Fingermark.

**STEPHENSON'S
 FURNITURE
 CREAM.**

OLD STRAW HATS MADE EQUAL TO NEW.

PEERLESS...

Straw Hat Polish

In all Colors. Dries in 10 Minutes.

Sold in 3d. & 6d. Bottles.

RESISTS DAMP. GLOSSY SURFACE. EASILY APPLIED.

STEPHENSON BROS., Ltd., BRADFORD, England.

SPECIAL PRICES TO CANADIANS UNDER THE NEW TARIFF.

DRAWING AND SURVEYING INSTRUMENTS, ETC.

English Make - The Latest, Best and Cheapest.

The Ideal Cases.

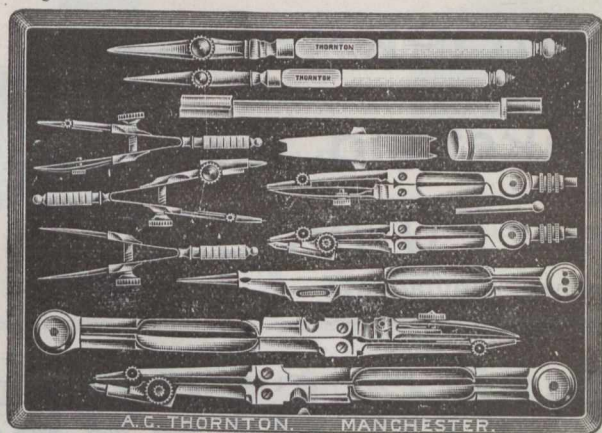

No. 5148. This Set in Electrum. Best Quality, with Needle Points and Double Joints, in Morocco flat Pocket Case, complete.

The most practical and serviceable Case, as also the cheapest for the quality ever offered. Compasses 6 in., and other instruments in proportionate sizes.

No. 5149. Same Set in Square Polished Walnut Case, with lock and key. Complete and extra, 4½ inch. Jointed Drawing Pen.

My special Cases of English Drawing Instruments range from \$/6 to £20. All made in my own factory, and the bulk are quite different to what are sold by any other maker or dealer in the Trade.

Loose Drawing Instruments of every description.

JUST PUBLISHED. POST FREE.—New and enlarged edition of Catalogue, 208 P.P., with Coloured Illustrations, giving full details and prices of all Specialities and Improvements to date.

No. 5132. The Standard Level.

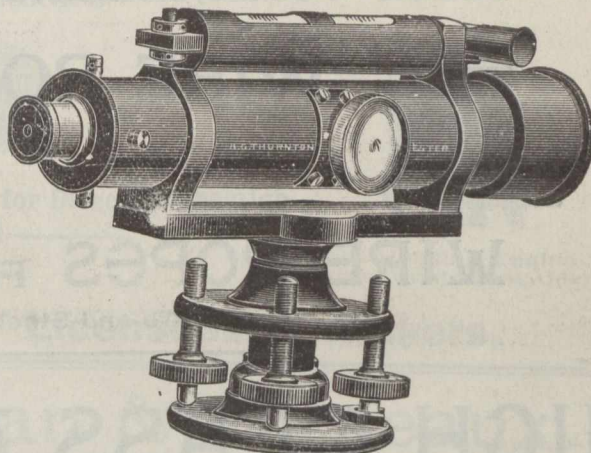

English make, 12 in. Telescope. Improved Pattern with Polished Mahogany Case and Tripod. Complete £8 10s., as illustrated.

No. 3637. The Desideratum Level, 12 in. Telescope, with Case and Tripod. Complete £4 17s. 6d.

Theodolites and Levels, Staves, Chains Tapes, Rods, &c. For particulars see Illustrated Catalogue, post free.

Repairs with promptitude and at moderate charges.

TRACING PAPERS AND CLOTHS.

As also Drawing Papers, every kind and quality. My specialities in above form a series of the very best and cheapest to be had. Samples and Prices, post free.

Photo Materials for Copying Tracings, every process. New Papers, Frames, Baths, &c.

CONTRACTOR TO
HER MAJESTY'S
GOVERNMENT.

TELEGRAMS:
DRAWING.—MANCHESTER.

A. G. THORNTON,

Practical Manufacturer. Exclusively Trading in this Branch.
99 St. Mary's Street, - MANCHESTER, ENG.



Agent for Canada: **E. A. BAYNES, 204 St. James St.,**

Montreal, Que.

Telegrams,
SHUTTLE,
DUNDEE.

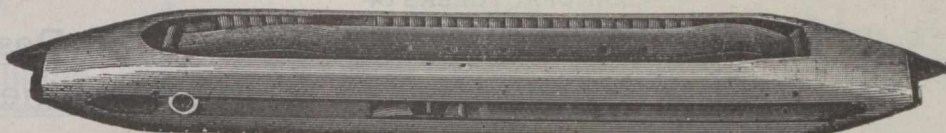

ESTABLISHED
1853

**McGregor
&
Balfour,
LTD.,**

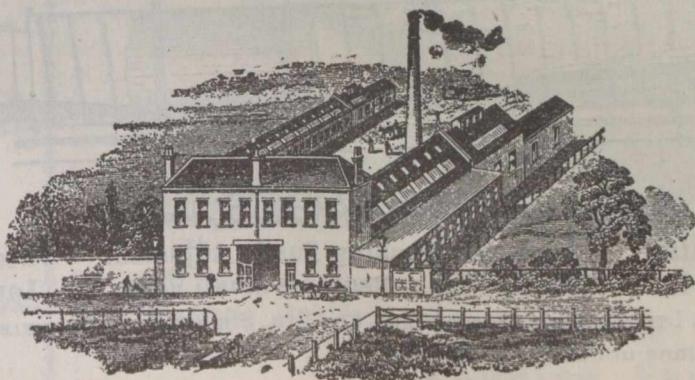

Shuttle, Bobbin,
Picker Spring and
Spindle
Manufacturers.
Leather Factors,
Mill, Factory and
Engineers'
Furnishers.

NORTH TAY WORKS.

DUNDEE, SCOTLAND.

INSURANCE, BANK and COMMERCIAL

PRINTING

Receives our Special Attention.

JOURNAL OF COMMERCE,
171 St. James Street MONTREAL.

Geo. Cradock & Co.

STEEL WORKS, ROLLING and WIRE DRAWING MILLS,
.....AND.....

WIRE ROPE WORKS

Makers
of

Wakefield, England.

WIRE ROPES FOR ALL PURPOSES

(From Wire and Steel of their own manufacture)

And

HIGH CLASS MINING STEEL.

BRANCHES:

LONDON - 7 East India Avenue, E.C.

JOHANNESBURG, S. A. - Bettelheims Buildings,
Symond Street.

SYDNEY, N.S.W. - Vickery's Chambers, Pitt Street.

Registered



Trade Mark.

TELEGRAMS: CRADOCK WAKEFIELD.

A.B.C. & ENGINEERING CODES USED.

AGENTS FOR CANADA

WINN & HOLLAND, = Montreal.

Mulholland, Maugham & Co. Ltd., West Cornforth,
Co. Durham, England.

MANUFACTURERS OF

Coal and Coke Handling Plant of all Descriptions,
Colliery Heapsteads and Mining Machinery - - -

The 'Blckett'
Coal Washer

(Blckett and . . .
Palmer's Patent.)

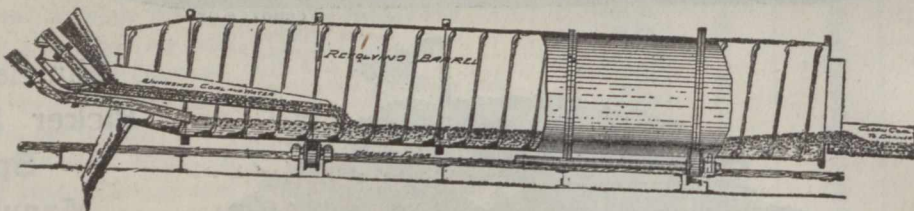

Capacity of each Ma-
chine per Day 150
to 200 tons.

ADVANTAGES

Cheap. Perfectly Automatic. Angle for Washing Easily Adjusted. Requires no Attention.
Efficient. Few Working Parts. No Leakage. Requires Small Room. Large Capacity. Simple.

Adopted by the CARLTON IRON CO., LTD., the THRISLINGTON COAL CO., LTD., SIR BERNHARD SAMUELSON & CO., LTD., and others.

Special Prices to Canadians under the New Tariff.

HUGHES' PATENT POWER PRESS

Patented in the United Kingdom, Germany
United States of America, Etc.

The Normanby Brick Company, Ltd.,

Patentees and Sole Manufacturers,

NORMANBY, Near MIDDLESBROUGH, ENG.

Are now prepared to offer their Patent Press Adapted to Steam Power.

This Machine has many advantages over the ordinary steam press of which the following are the chief, viz: 1.—Every brick is one exact thickness when it leaves the box, the only variation being in the depth of the panel. 2.—The stretcher parts are absolutely free from Arris. 3.—Equal pressure and 2 nips are brought to bear on each side of the brick, which prevents twisting and the pressure can be increased or reduced as desired. 4.—The repairs are reduced by about 50%. 5.—Capacity from Eight to Ten Thousand per day of 9½ hours. 6.—Hands required to work the machine, four boys.

The Machine can be seen at work at the above works any day by appointment.

For all further particulars apply as above.

Special prices to Canadians under the new Tariff.

Contractors To The Admiralty.

DONKIN & CO.,

St. Andrew's Works,

Newcastle-on-Tyne, England.

Patentees and Makers.

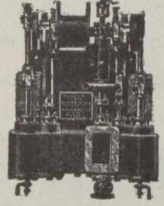
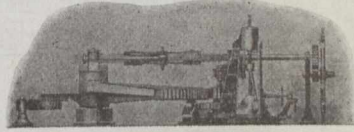
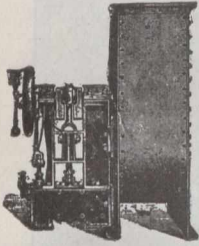

Combined Hand & Steam Steering Gear for Direct Connection
with Rudder Head
(Wilson & Pirrie's Patent.)

Ash Hoisting Engine,
Patent Controlling Gear.

DONKIN & CO.,

Licensees & Makers.

Dominion Paper Co'y

134 MCGILL STREET;

MONTREAL.

Mills at Kingsey Falls, P.Q.

Manufacturers of the following grades of

High Class Papers:

- Nos. 1 & 2 Book and Printing (Toned and White).]
- No. 3 News and Printing " "
- White Tea and Bag.
- Bleached Manilla, Envelope, Bag and Wrapping.
- White Manilla, Tea and Wrapping.
- Unbleached Manilla, Tea and Wrapping.

..Chapman & Furneaux..

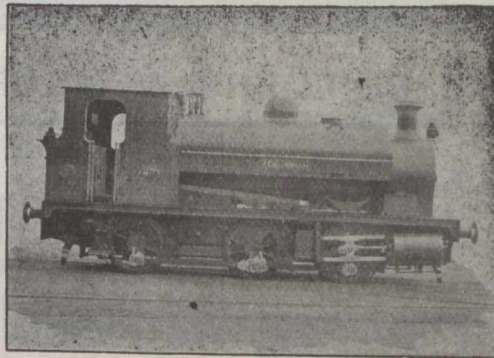

Locomotive Engineers,

GATESHEAD-ON-TYNE, ENGLAND.

Manufacturers of Locomotives to suit any gauge of Railway and adapted to every variety of service. To burn Coal, Coke, Wood or Petroleum.

Cable Address : "BLACKTHORN, Gateshead-on-Tyne."

Speciality : Heavy Tank Engines for Mineral Traffic.

Special terms to Canadians under the New Tariff.

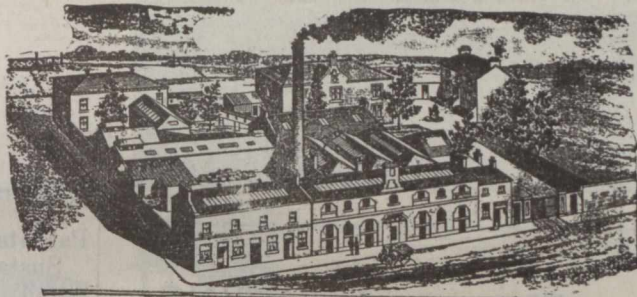

DUNDEE AND ARBROATH CONFECTIONS AND PRESERVE MANUFACTURING COY LTD.

....MANUFACTURERS OF....

Jams, Jellies, Confectionery, Marmalades, and Ganded Peels.

All Communications to be addressed to Arbroath, Scotland.

Commercial, Insurance

.. AND GENERAL

Book & Job Printing ..

EXECUTED WITH CARE AND PROMPTNESS

AT THE OFFICE OF

The Journal of Commerce

171 & 173 ST. JAMES ST.,

MONTREAL.



- Bill Heads. Statements. Catalogues.
- Note Heads. Business Cards. Folders.
- Letter Heads. Circulars. Price Lists.
- Etc., Etc.



Caverhill, Learmont & Co.,

Wholesale **HARDWARE & METAL MERCHANTS**

Caverhill's Buildings St. Peter St.,

Largest and most complete stock of SHELF HARDWARE in the Dominion.

MONTREAL

Telegraphic Address :—" LOCO., GLASGOW."

SHARP, STEWART & CO., LTD.

Atlas Works,  GLASGOW, SCOTLAND

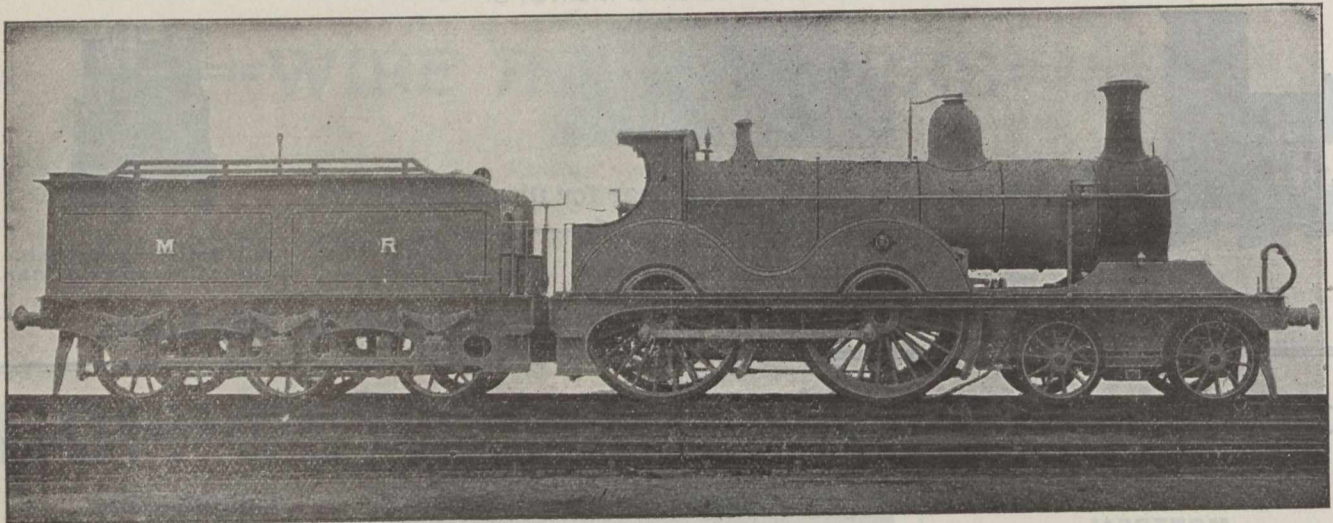

LOCOMOTIVE ENGINE BUILDERS & MACHINE TOOL MAKERS.

THE DUNDEE SHIPBUILDERS CO., LTD., Established 1842.
 Successors to ALEXANDER STEPHEN & SONS,
Iron, Steel and Wood Shipbuilders and Repairers.
 DUNDEE, SCOTLAND.

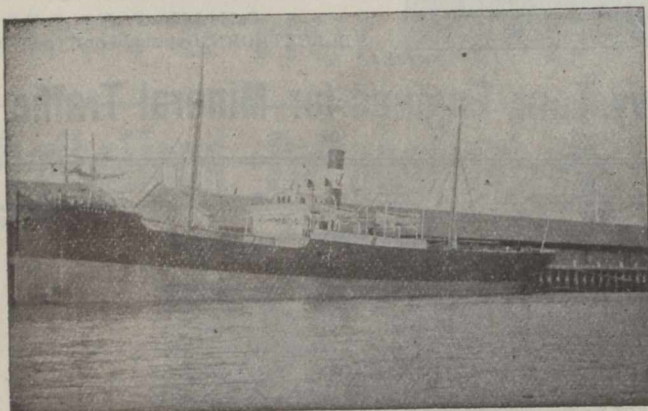

When you Figure on **PRINTING**
 FIGURE ON US.

JOURNAL OF COMMERCE JOB DEPT.

Telegrams, NORMANBY.

The Normanby Iron Works Co.
 LIMITED.

Normanby Iron Works, Middlesbrough, England.
 Brand HEMATITE "N. H. H."

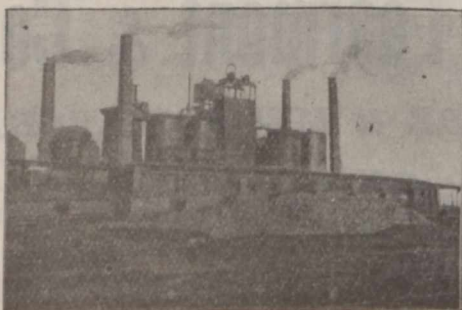

Special terms to Canadians under the New Canadian Tariff. And all kinds of HOISTING MACHINERY. Designs & Estimates on application.

Telegraphic Address:—" EXPANDERS, GLASGOW."

William Thomson

& CO.,

General Engineers and Smiths,
 57 Smith Street, KINNING PARK,
 Glasgow, Scotland.

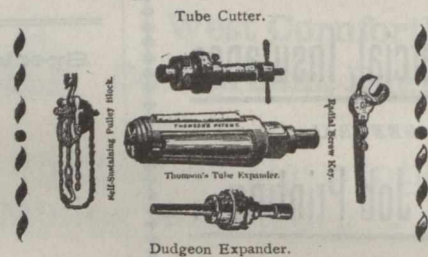

Repairs of every description promptly executed.

Patentees and Sole Makers of Thomson's Patent Self Sustaining Screw Pulley Blocks, Tube Expanders, Tube Cutters, Etc., Etc. Also Makers of Dudgeon's Tube Expanders.

JOHN GRIEVE & Co.

MOTHERWELL, - SCOTLAND.

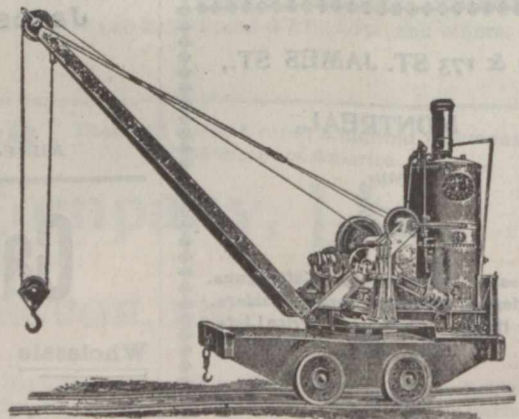

— MAKERS OF —

Steam, Hand, Hydraulic, Electric, **CRANES**

Special terms to Canadians under the New Canadian Tariff. And all kinds of HOISTING MACHINERY. Designs & Estimates on application.

B. BULLOCK LIMITED.
 EXCELSIOR CONFECTIONERY WORKS,
DEWSBURY, ENG.

EVERYBODY'S MIXTURES.

LOZENGES
 PAN-GOODS
 GELATINE
 GOODS
 BOILED-SUGARS

JELLY
 TIT-BITS

ORIGINAL & SOLE MAKERS OF THE NOTED REAL YORKSHIRE HONEY & BUTTER TOFFEE.

TRADE MARK

SWEETS ALL AND EVERY SORT
 MADE TO ORDER.

TELEGRAMS: "JONAS WELLS, KEIGHLEY."

IMPORTANT TO Engineers, Machinists, Colliery Proprietors, and Railway Wagon Owners, &c., &c.

JONAS WELLS,
 Brass, Malleable Iron and Steel Founder,
 GREENGATE WORKS, KEIGHLEY, Eng.

Special terms to Canadians under the New Canadian Tariff

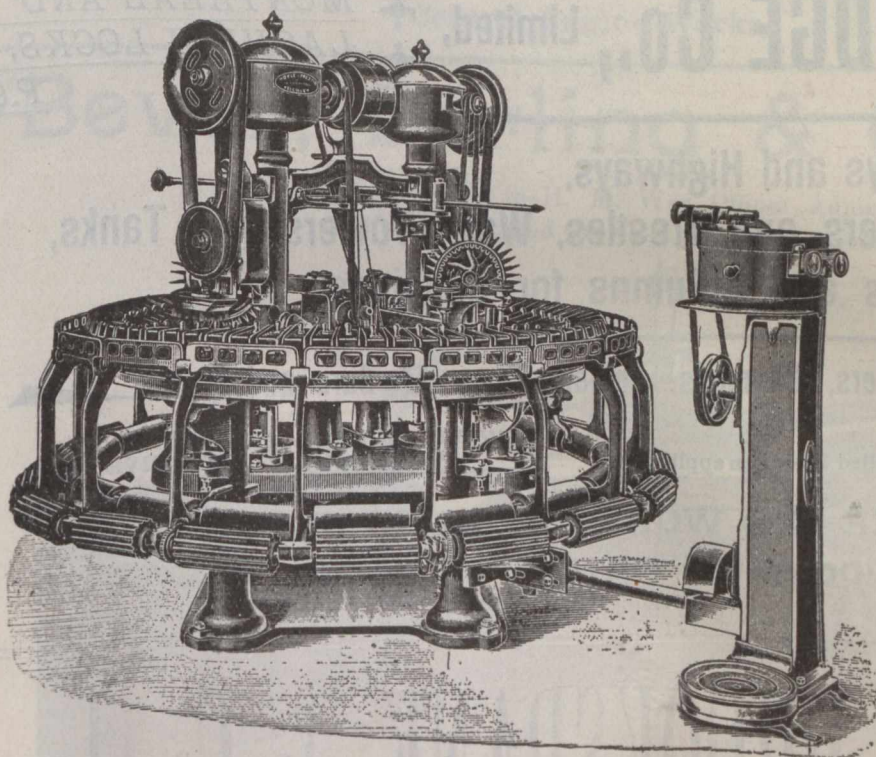

HOYLE & PRESTON,
 Machine Makers, Keighley,
 ENGLAND.

GLOBE IRON WORKS.

Noble Wool Combing Machines, Lister Wool Combing Machines, Hand Wool Scouring Machines, Self-Acting Wool Scouring Machines, Hot and Cold Air Wool Drying Machines, Back Washing Machinery of every Description, Grease Presses on Screw or Hydraulic Principle, Yarn Scouring Machines, Yarn Crossing Presses, Warming Mills, all on the most recent and improved principles, all Accessories and Fittings pertaining thereto, all Description of Iron and Brass Castings, &c., &c.

MOUNT BROS.,
 Manufacturers and
 Dealers in . . .

Electrical Supplies,

Wiring and Electric Light Contractors.
 Bells, Annunciators Telephones, etc.
 784 Craig St.. - Montreal.

Individual Evening Instruction.
 ON
 Monday, Wednesday and Friday Evenings
 AT

The Montreal Business College

Corner Victoria Square and Craig Street

Book-keeping, Arithmetic, Penmanship, Shorthand, Type-writing, Correspondence English, French, Civil Service, etc. Students select their subjects and are taught separately by nine expert teachers. Write, call or telephone Main 2890 for Prospectus and new price list. Address,

J. D. DAVIS,
 42 Victoria Sq., Montreal

Edwards & Rawson, Limited,

SERGES: Blue (Indigo dyed) and all colors. Long Faced WOOLLENS, BAIZES, CAMLETS, &c.

Canai Mills, Halifax, England.

ARTHUR GAGNON
 Manager Estate
 Hon. Jeap L. Beaudry

L. A. CARON
 Auditor Town of Maisonneuve and of la Chambre de Commerce du District de Montreal.

GAGNON & CARON,
 Rooms 41 & 42 Montreal St. Ry. Bldg., Montreal.
 Accountants, Curators, Liquidators and Commissioners, S. C. Bell Tel. Main 815.

Edwin C. Lewis Co.,

Contractors for the
 Installation of
 Electric Lights,
 Bells, Telephones,
 Etc. . . .

Boston Office: 67 Federal Street, Boston, U. S. A.
 Montreal Office: Temple Building, Montreal, Que.

TO LET.

One Suite of Rooms in . . .
Bellevue Apartments,
 METCALFE ST.

Apply for Permit to
M. S. FOLEY.
 171 St. James St.

Telegraphic Address POTTER, ENGINEER, OTLEY.

ESTABLISHED 1897.

J. W. POTTER & CO.,

Prospect Works OTLEY, YORKS, England.

..Printers', Engineers and Machinists..

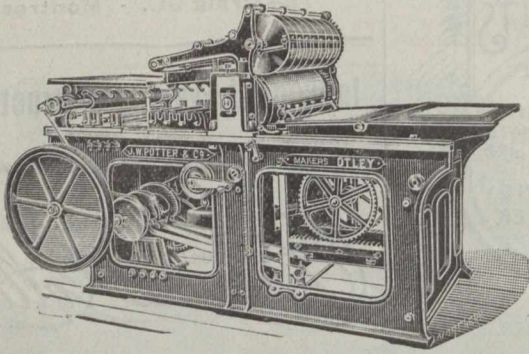

Makers of the Latest Improved Wharfedale Letterpress, and Two-Colour Machines, Lithos, Platens, Guillotines and Self-Clamp Cutting Machines. : : : : : :

And every description of Special Machinery for Letterpress and Lithographic Printers, Bookbinders, Stationers, etc. Gear Machine-Cut throughout.

Quotations for any size and every kind of Machine for the Printing Trade forwarded on application.

Stationery

— A Special Line.

Good, Straightforward Stationery at straightforward prices.

Journal of Commerce Job Department,

Send for Estimate.

171 St. James Street.

Mall Orders receive our best attention.

DOMINION BRIDGE Co., Limited, ✦ MONTREAL AND LACHINE LOCKS, P.Q.

Bridges for Railways and Highways,
Piers and Trestles, Water Towers and Tanks,
Roofs, Girders, Beams and Columns for Buildings,

A large Stock of Rolled Steel Beams, Girders, Channels, Angles, Tees, Z Bars and Plates.

Tables, giving Sizes and Strength of Rolled Beams on application.

ALWAYS ON HAND IN LENGTHS TO THIRTY-FIVE FEET.

Post Office Address: MONTREAL.

OFFICE AND WORKS AT LACHINE LOCKS,
(DOMINION STATION, C. T. Ry.)

Telegrams,
"QUADRUPLE,
KEIGHLEY."

E. BROOKSBANK & Co., LTD.,

• SPECIAL Prices to Canadians under the New Canadian Tariff.

Station Oil and
Soap Works . .

KEIGHLEY,
England.

... THE ...
JOURNAL OF
COMMERCE



Spring Specialties
Knicker Hose and Fancy Sweaters.

A. MACDOUGALL & Co.,

MANUFACTURERS OF

Plain and Fancy Hosiery,

LANARK, SCOTLAND.

Patentees of Special Design Making Machine.



Established 1820.

Telegrams: "BREARLEY, SHIPLEY."

BOOK & JOB DEPARTMENT.

Send for Estimates.

High Class Horizontal Disc Crank Steam Engine.

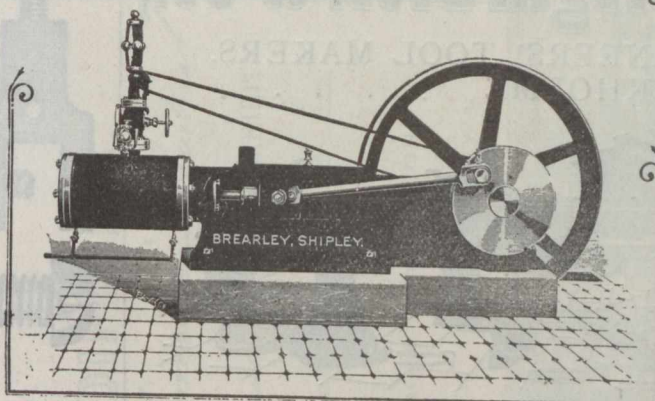

FAIRBANK BREARLEY,

Central Engine Works,

SHIPLEY, England.

171 St. James Street,

— MONTREAL. —

Bever, Dorling & Co., Ltd.,

Contractors to H. M. War Offices Admiralty,
India Offices, and Crown Agent for the Colonies.

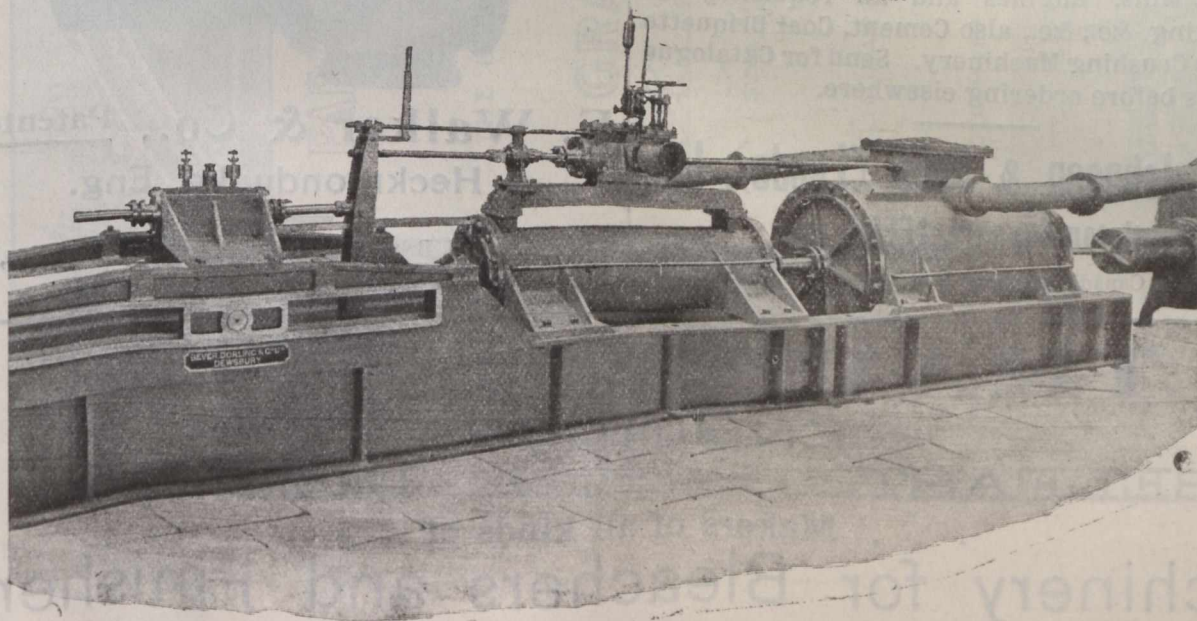

Makers of High-Class **STATIONARY ENGINES** for Factories, &c.
AIR COMPRESSOR ENGINES A SPECIALITY.

DUPLEX PUMPS

For Boiler Feeding, General Marine Purposes,
Mines and Hydraulic Power

IMPROVED TEA MACHINERY.

REGISTERED OFFICE AND WORKS:

PATENT FRICTION CLUTCHES.

Queens Foundry,

Dewsbury, England,

Spades, Picks,

KITCHEN FENDERS, STANDS, &c.
VICES, WATER TUE IRONS, &c.

Contractors'
Tools. =====

Leedham & Heaton, Limited,

Armley Road Iron Works, ===== LEEDS, ENGLAND.

(Cuts will be inserted as soon as received.)

Pickersgill Bros. & Co.,

ENGINEERS' TOOL MAKERS,
LAWKHOLME

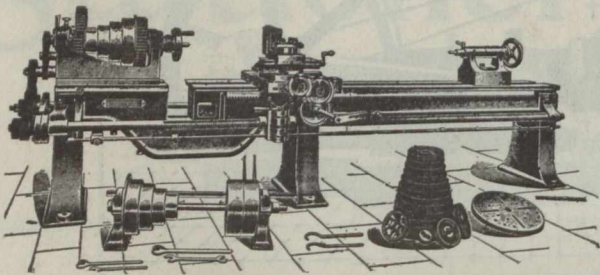

KEIGHLEY, Eng.

BRICKMAKING MACHINERY

To suit all kinds of material, Plastic, Semi-Plastic, Stiff-Plastic, Semi-Dry and Dry Machinery. Presses, Grinding Mills, Engines and all requisites for Brickmaking, &c., &c., also Cement, Coal Briquette and Stone Crushing Machinery. Send for Catalogue and Prices before ordering elsewhere.

William Johnson & Sons, (Leeds), Ltd.
Castleton Foundry, LEEDS, Eng.

Special terms to Canadians under New Tariff.

**THE BEST SCREWS
IN ENGLAND**
THE
AUTOMATIC
STANDARD SCREW
COMPANY
MALIFAX
ENGLAND.

By His Majesty's Letters Patent.

... THE ... Health Water Pipe.

It conducts water without poisoning it



E. Walker & Co., Patentees,
Heckmondwike, Eng.

Highest Award British Medical Association Exhibition, also
Two Gold Medals Awarded.

TRAVERS & CO.,

✧ ENGINEERS, ✧

BELFAST, + + + IRELAND.

Makers of all kinds of . . .

Machinery for Bleachers and Finishers.

SPECIALITIES.

Hydraulic Mangles.

Heavy and Light Calenders.

High Speed (Patent) Beetling Machines.

Damping Machines for Cloth.

Water and Starch Mangles.

Drying Cans.

Yarn Squeezers.

Wooden Beetling Engines.

Rub Boards.

Wash Mills.



PARIS·UNIVERSAL·EXHIBITION
OF·1900

THE INTERNATIONAL JURY OF AWARDS HAS
GRANTED A

GRAND·PRIZE·DIPLOMA

TO *The Journal of Commerce Montreal*
A Contributor to International Exhibit.

GROUP _____ CLASS _____

PRELIMINARY CERTIFICATE.

ISSUED BY THE CANADIAN COMMISSION.

OTTAWA.

DECEMBER, 1900.

Locomotives
for all Pur-
poses.
Boilers.
Ships.
Pontoons.
Dock Gates.
Creosoting
Plant.
Oil Engines.
Locomotive
Cranes.
Pumps.

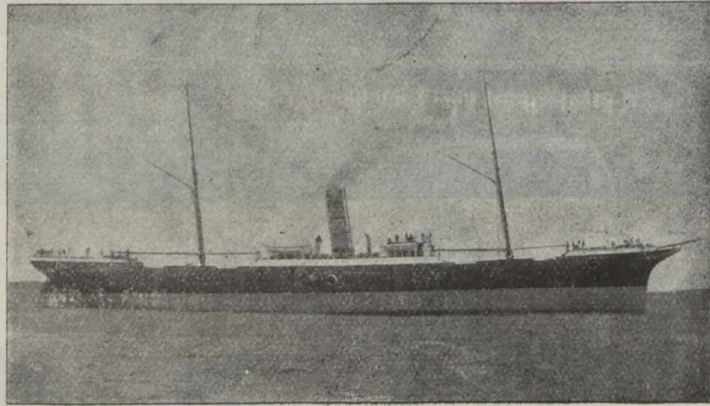
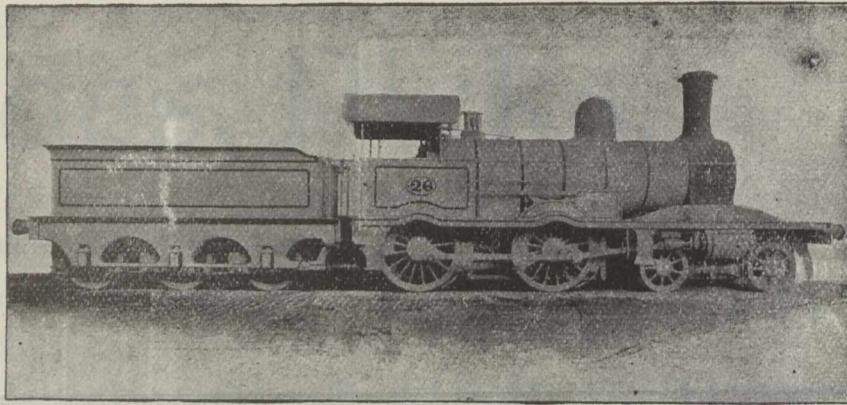

High Speed
Vertical
Steam En-
gines
Rock Drills.
Hauling and
Winding
Gear.
Ball Mills.
Iron
Castings of
Special
Quality.

ROBERT STEPHENSON & Co., LTD.,

Registered Offices: **NEWCASTLE-ON-TYNE, - - ENGLAND.**

TELEGRAMS: "ROCKET, NEWCASTLE-ON-TYNE."

DORMAN, LONG & CO., Limited, MIDDLESBROUGH, ENG.

London Office: 19 Victoria St., Westminster
ENGLAND.

Stock Yards at Works and Nine Elms Lane, London, also at Melbourne, Australia.

Telegrams, "DORMAN," Middlesbrough.

MANUFACTURERS OF

SPECIALITY

STEEL AND IRON

(Steel by the Siemens-Martin Process.)

STEEL ROLLED JOISTS.

Brand: "DORMAN, LONG & CO., Ltd."

No. of Section.	Size.	Weight per foot.	No. of Section	Size.	Weight per foot.
G 1	20 x 7 1/2	89 lbs.	G 17	7 x 3 3/4	18 lbs.
G 2	18 x 7	75 lbs.	G 17A	7 x 3 3/4	18 lbs.
G 3	16 x 6	62 lbs.	G 18	6 1/4 x 3 1/2	16 lbs.
G 3A	16 x 5	50 lbs.	G 19	6 x 5	25 lbs.
G 4	15 x 6	59 lbs.	G 19A	6 x 4 1/2	20 lbs.
G 5	15 x 5	42 lbs.	G 20	6 x 3	16 lbs.
G 6	14 x 6	57 lbs.	G 20A	6 x 3	13 lbs.
G 6A	14 x 6	46 lbs.	G 21	6 x 2	12 lbs.
G 6B	13 x 5	41 lbs.	G 22	5 1/2 x 2	11 lbs.
G 7	12 x 6	54 lbs.	G 22A	5 1/2 x 1 1/2	9 lbs.
G 7A	12 x 5	32 lbs.	G 23	5 x 5	24 lbs.
G 7B	12 x 6	44 lbs.	G 24	5 x 4 1/2	22 lbs.
G 8	12 x 5	39 lbs.	G 24A	5 x 4 3-16	19 lbs.
G 9	10 x 8	70 lbs.	G 25	5 x 3	15 lbs.
G 10	10 x 6	45 lbs.	G 25A	5 x 3	11 lbs.
G 10	10 x 5	35 lbs.	G 26	4 3/4 x 1 3/4	10 lbs.
G 10A	10 x 5	29 lbs.	G 26A	4 3/4 x 1 3/4	6 1/2 lbs.
G 11	10 x 4 1/2	30 lbs.	G 27	4 5/8 x 3	14 lbs.
G 11B	9 3/4 x 3 3/4	21 1/2 lbs.	G 28	4 x 3	12 lbs.
G 12	9 x 7	58 lbs.	G 28A	4 x 3	9 1/2 lbs.
G 13	9 x 3 3/4	20 lbs.	G 29	4 x 1 3/4	8 lbs.
G 14	8 x 6	35 lbs.	G 29A	4 x 1 3/4	5 lbs.
G 15	8 x 5	30 lbs.	G 30	3 1/2 x 3	10 lbs.
G 16	8 x 4	25 lbs.	G 31	3 1/2 x 1 1/2	6 lbs.
G 16A	8 x 4	19 lbs.	G 32	3 x 3	10 lbs.
			G 33	3 x 1 1/4	4 lbs.

Makers of COMPOUND and PLATE GIRDERS, STANCHIONS, Etc.

All sizes of ANGLES and CHANNELS.

FLOORING of Lindsay's and Special Sections: Bulbs, 6-inch to 12-inch; Rounds, 1/2-in to 7-in; Half-Rounds, 1 1/2-in to 3 1/2-in.; Squares, 1/2-in. to 4-in.; Flats, 1-in to 18-in.; Rails up to 56 lbs. per yard. Tees, Bulb-Tees, Zeds, etc., for Engineering, Ship-building and Wagon Work.

12,000 tons of all sections kept in stock.

Manufacturers of Galvanized, Corrugated and Plain SHEETS, 16 to 28 gauge. Usual lengths and widths.

Manufacturers of TELEGRAPH WIRE, WIRE RODS, Bright, Galvanized STRAND & BARB WIRE. Varnished and Galvanized FENCING WIRE.

STEEL WIRE FOR ROPES.

SPECIAL PRICES TO CANADIANS UNDER THE NEW TARIFF.

SECURITIES.		London July 25	
British Columbia, 1877 6 p.c.	104	108	
1887, 4 1/4 per cent	90	92	
1891-3, 3 p.c.	104	106	
Canada, 4 per cent. loan, 1880	99	101	
3 per cent. loan, 1888-99	101	103	
Debs. 1884, 3 1/2 per cent	88	90	
2 1/4 p.c. loan, 1897	106	108	
Manitoba, 1885-6, 5 p.c.			
SHS Railway and other Stocks.		July 25.	
Quebec Province, 5 p.c., 1874	102	106	
1876, 5 p.c.	102	106	
1880, 4 1/4 p.c.	101	103	
1883, 5 p.c.	107	109	
Atlantic & Nth. Western 5 p.c. Gua	117	120	
1st M. Bds	13 1/4	13 3/4	
100 Buffalo & Lake Huron \$10 shr	138	142	
do 5 1/4 p.c. 1st mort.	138	142	
do 2nd mort			
Can. Central 6 p.c. M. Bds. Int.			
guar. by Gov.			
Canadian Pacific \$100	104	105	
Grand Trunk, Georgian Bay, &c.	101	103	
1st M.			
100 Grand Trunk of Canada Ord. stock	9 3/8	9 3/4	
100 2nd equip. mtg. bds. 6 p.c.	124	127	
100 1st pref. stock 5 p.c.	93 3/4	94 1/4	
100 2nd pref. stock	77 3/4	78 1/4	
100 3rd pref. stock	32	32 1/2	
100 5 p.c. perp. deb. stock	133	136	
100 4 p.c. perp. deb. stock	104	106	
100 Great Western shares, 5 p.c.	127	130	
100 Hamilton & N.W., 6 p.c.	105	107	
100 M. of Canada Stg. 1st Mort. 5 p.c.	99	101	
100 Montreal & Champlain 5 p.c. 1st	99	101	
mtg. bds	44	47	
100 N. of Canada, 1st mtg., 5 p.c.	99	101	
100 Quebec Central, 5 p.c. 1st Inc. Bds.	103	106	
100 T. G. & B. 4 p.c. bonds, 1st mort.	111	115	
100 Well., Grey & Bruce, 7 p.c. bds.	103	105	
100 1st Mort			
100 St. Law. & Ott. 4 p.c. Bds			
MUNICIPAL LOANS.			
100 City of London (Ont) 1st pref 5 p.c.	101	103	
100 City of Montreal stg. 5 p.c. 1874	103	106	
100 City of Ottawa, 4 1/4 p.c. stg.	101	104	
redeem 1873	104	106	
redeem 1875			
100 City of Quebec, 6 p.c. redeem 1875	105	107	
redeem 1873	100	102	
100 City of Toronto, 4 p.c. 1889-93	103	109	
6 p.c. stg. con. deb. 1874-1876	113	115	
5 p.c. gen. con. deb. 1879	103	105	
4 p.c. stg. bonds	107	109	
100 City of Winnipeg deb., 1884, 5 p.c.			
Deb scrip. 1883, 6 p.c.			
MISCELLANEOUS COMPANIES.			
100 Canada Company	34	37	
100 Canada North-West Land Co.	3	5	
100 Hudson Bay	20 1/4	20 3/4	
BANKS.			
Bank of British North America	65	67	
" " Montreal	518	522	
Canadian Bank of Commerce	15	16	

The Sylvester Gas and Gasoline Engines

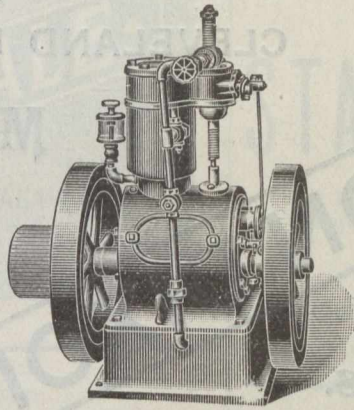

are, beyond doubt, the most complete and economical Engine on the market. They are compact and perfectly under control, easily managed, get up speed immediately, thoroughly reliable and where intermittent power is required, they are just the thing.

They are built in sizes from 1 to 20 horse power, upright and horizontal, for pleasure yachts, boats, shops, farm work and any purpose where light power is required.

Tell us to what use you want to put the engine and what power you require, and we will name you prices.

The SYLVESTER BROS. M'FG CO., Lindsay, Ont.

New Patent Gas Engine.

Type of 4 to 10 H.P. Engine, Nominal.

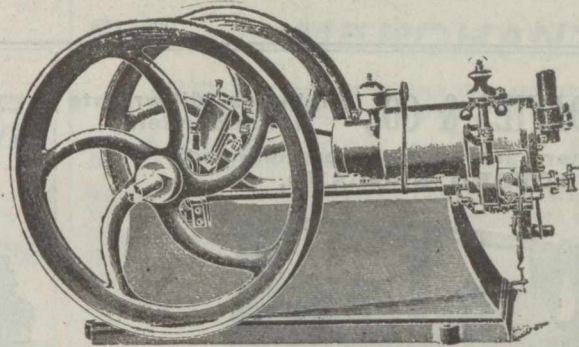

Ignition Tube and Burner.

SPETCH & THOMAS,

SOLE MAKERS,

Paragon Engine Works, Longside Lane, BRADFORD, ENGLAND.

SPECIAL TERMS TO CANADIANS UNDER THE NEW TARIFF.

ESTABLISHED 1890.

"STRATHMORE" CYCLES.

IRVING BROTHERS,

Cycle Manufacturers, Gas Engine and Motor Engineers, DUNDEE and COUPAR ANGUS, SCOTLAND.

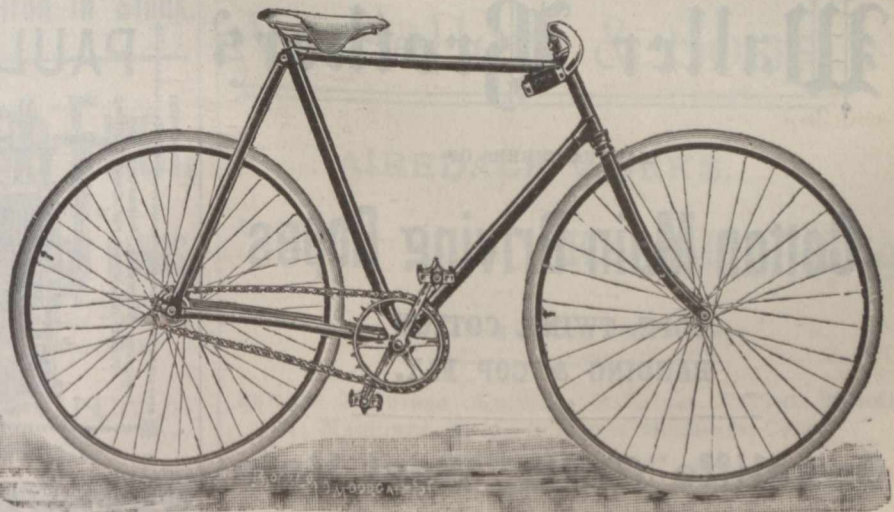

Special Terms to Canadians under the New Tariff.



LARGEST MAKER

IN THE WORLD.

200 TO 300

IN 50 Different Sizes in Stock.

Can Despatch on Receipt or Wire.

ENGLAND.

Shipbuilders, Engineers and Repairers,
CLEVELAND DOCKYARDS,
Middlesbro',
England.

Telegraphic Address:
 "DIXON, MIDDLESBRO'."

SIR RAYLTON DIXON & CO., LIMITED.

Special attention and despatch given to

**Repairs of Vessels,
 Engines and Boilers.**

GRAVING DOCK, 576 Feet Long.

Hydraulic Slipway, capable of taking vessels up to 2,000 tons gross register.

London Office:
ROBERT STEELE, 6 Gracechurch St., E.C.

EDWARD DAVIES & CO., Engineers, Millwrights & Ironfounders,
 Water Lane Works, Thornton Road,
BRADFORD, ENGLAND.

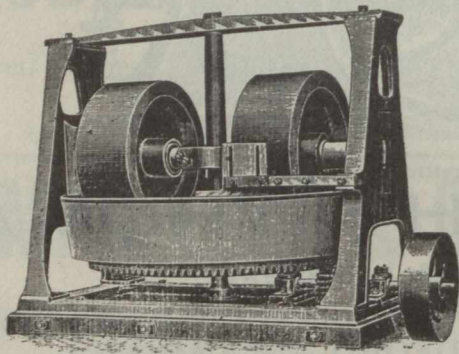

.....Makers of.....

Hydraulic Pumps, Horizontal and Vertical Steam Engines, Improved Warp Steeping Motion, Dyeing, Sizing, Drying, and Balling Machines, Indigo Vats, Crabs, Pads, Dolleys, and Hoists, Cranes, Shafting, Wrought & Cast-Iron Pulleys, Plummer Blocks, Couplings, Hingers, and Gearing Mortar Mills and Castings.

Repairs Promptly Attended to.

Special prices to Canadians under the New Tariff.

Telegrams:—"Waller, Greetland."

Waller Brothers

MANUFACTURERS OF

Cotton Main Driving Ropes

ROPE, TWINE, COTTON
 BANDING & COP FLY.

**Onecliffe Mills, West Vale,
 near Halifax, England.**

..Dewhirst's Gas Engine..

IMPROVED "OTTO"

LEADING FEATURES:

Simplicity with Economy. Silent and Steady Running. Steady Impulse without Shock. Low consumption of Gas. Positive Governing. Easy to start. High-Class Workmanship. Neat in Design. Durable and Reliable. Change of Speed while running. Anti-Fluctuator Gas Bag. Electric Light Governors. Automatic Lubrication. Minimum Prices.

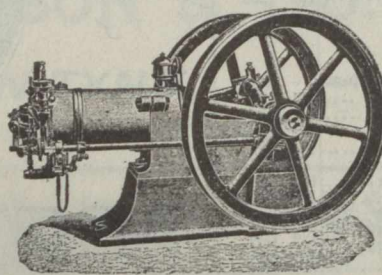

SOLE MAKER:

C. H. DEWHIRST,
GAS ENGINE WORKS,

Telegrams: "Dewhirst, Engineer, Keighley."

KEIGHLEY, Yorks, Eng.

Special Rates to Canadians under the Preferential Tariff

PAUL DRACUP & CO.,

Makers of Double and Single Lift

JACQUARDS.

HARNES TIER UP.

WEST END MILLS, Richmond Road,
BRADFORD, ENGLAND

Improved Stamping, Repeating and Plano Machines for Card Cutting.

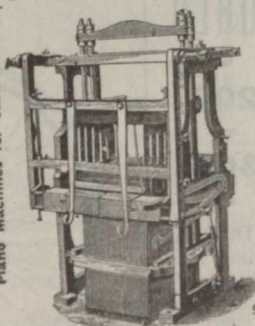

SPECIAL PRICES TO CANADIANS UNDER THE NEW TARIFF



THE

Weardale Steel, Coal, ... & Coke Co., Ltd.,

Tudhoe Ironworks,
Spennymoor, Durham, England.

MANUFACTURERS OF

MILD STEEL PLATES AND SHEETS

For BOILERS, LOCOMOTIVE FRAMES, &c.

Admiralty, War Office, Board of Trade, Lloyd's, Bureau Veritas,
British Corporation and other Tests.

Also SHIP, BRIDGE, and GIRDER PLATES.

LARGEST PLATES IN THE TRADE.

Steel Bars, Angles, Tees, Hoops, Strips, Single Round Edge Tyre
Bars for Carriages, Vans, and Omnibuses, &c.

ALL STEEL MADE BY SIEMENS' ACID PROCESS.

Of the Highest Quality.

IRON Bars, Angles, Tees, S.R.E. Tyre Bars, &c.

BRANDS:

STEEL, "WEARDALE STEEL." IRON BARS, "WEARDALE."
TUDHOE BEST SCRAP "TUDHOE CROWN and DIAMOND T."

PIG IRON.

WEARDALE, for Rollers, Cylinders, Plough Shares, and other Chilled
Castings. HEMATITE, for Steel Making and Foundry Purposes.

Colliery Proprietors and Coke Manufacturers.

House, Steam, Manufacturing, and Gas Coals. Coke for Foundry and Blast
Furnace use. Silica Bricks for Lining Steel Melting Furnaces.
Fire Bricks and Fire Clay.

OFFICES:

Tudhoe Ironworks, SPENNYMOOR. Mercantile Chambers, Quayside,
NEWCASTLE-ON-TYNE. 18 Grosvenor Chambers, Deansgate, MANCHESTER.
George Yard, Upper Thames St., LONDON, E.C. Royal Exchange,
MIDDLESBROUGH. Victoria Terrace, WEST HARTLEPOOL.

WAREHOUSE:

GEORGE YARD, UPPER THAMES STREET, LONDON, E.C., ENG.

Nearly 3000 Tons of Steel and Iron in Stock.

If you want to Save Fuel,



Have your Pistons fitted with
The "ROWAN" PISTON RINGS,

Perfectly Steam-tight, with a minimum of
friction. May be fitted to Existing Pistons.

Sole Patentee and Manufacturer,

JOHN HIND, JUN.,
8 Ulster Chambers,
... BELFAST, Ireland.

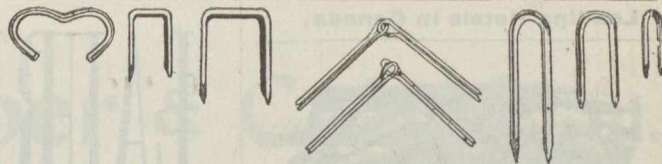

STAPLES, TINNED & COPPERED FLAT STAPLES. LINGOES OR LOOM WEIGHTS.

Box Hinges. Reed Ends. Jacquard Wires (perfectly
straight.) All kinds of ROLLED WIRE, (cut or in coil)

JOSEPH HIRST,

Kirklees Ironworks, Brighouse, Eng.

Please write for lists & samples.
Special terms to Canadians under new tariff.

William Whitwell & Co., Ltd.,

Thornaby Iron Works,

Stockton-on-Tees, - - - England.

Manufacturers of Whitwell Special
Admiralty Cable 1/4 inch and upwards.

PIG AND MERCHANT IRON.

PIG IRON for Bessemer, Siemens, Basic and Forge Purposes.

Brand for Pig Iron: THORNABY, HEMATITE.

MERCHANT IRON Angles, Tees, Rounds, Squares,
Flats, Round Edged Flats, Oc-
tagons Ovals, Feather-Edged Convex, Square Edged Convex,
True Half Rounds; Rails—bridge double and single headed flat
bottomed and street; Fish Plates, Fencing Iron, Sleeper Iron,
Bevel Edged Tyre Iron, Channel, Skylight, Bevel and Hollow
Moulding Iron Fire and Screen Bars, Tube Strips, Sash Iron,
Single and Double Grooved Shoe Iron.

Capacity, 2,500 tons of Pig Iron, and 750 tons of Bar Iron, per week.

Brands for Merchant Iron: W. W. & CO. BEST SHOE, THORNABY BEST,
W. W. & CO. BEST, THORNABY BEST BEST, THORNABY, W. W. & CO.

Special Terms to Canadians under the New Tariff.

JOHN TURNER & CO.,

Manufacturers of HORSE RUGS

Blankets, Rugs, Horse Clothing, Collar Checks, Saddle
Girths, Rollers Body Belts, and Webbing. Jute and
Combination Night Sheets in all sizes.

Merchants and Shippers only Supplied.

CROWN MILLS, SAVILE TOWN, DEWSBURY, YORKSHIRE, ENGLAND.

W. Sellers & Sons,

AIREDALE WORKS,

Established
1854.

Keighley, Eng.

MANUFACTURERS
OF

SEWING MACHINES, KNITTING MACHINES, PATENT WASHING
MACHINES, KNIFE CLEANING MACHINES, CYCLE
AND MOTOR CARS.

Leading Hotels in Canada.

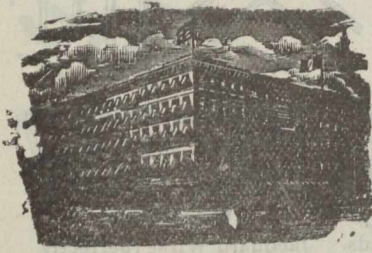

ROSSIN HOUSE, TORONTO, Canada.

A. Nelson, Proprietor.

The proprietor has found necessary owing to the increased patronage of this popular Hotel to increase its capacity by an addition of 75 rooms, elegantly furnished en suite with baths, now ready for occupation. The latest exposed sanitary plumbing has been adopted throughout. THE ROSSIN is admittedly the largest, best appointed and most liberally managed hotel in the Province, having accommodation for 500 guests.

A. NELSON, Proprietor.

THE RUSSELL,
OTTAWA.

THE PALACE HOTEL OF CANADA.

This magnificent new Hotel, fitted up in the most modern style, is now re-opened. The Russell contains accommodation for over Four Hundred Guests, with passenger and baggage elevators and commands a splendid view of the City, Parliamentary grounds, river and canal. Visitors to the capital having business with the Government find it most convenient to stop at the Russell, where they can always meet the leading public men. The entire Hotel is supplied with escapes; and in case of fire there would not be any confusion or danger. Every attention paid to Guests.

F. X. ST. JACQUES, Propr.

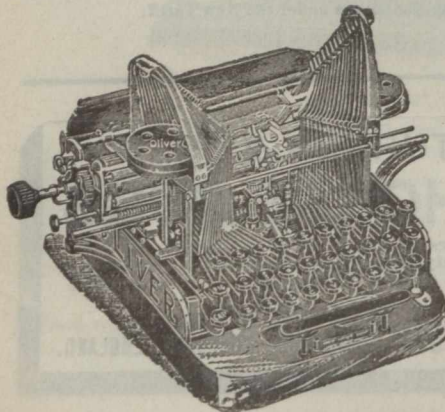

YOUR ATTENTION!

THE OLIVER . .

Free Type Bar

Visible Writing

TYPEWRITER.

Price in Canada & United States,

\$95.00

LINOTYPE COMPANY,

156 St. Antoine Street,
MONTREAL.

Manufacturers for
CANADA AND SOUTH AMERICA.

LAURIESTON IRON CO'Y,

Manufacturers of

Registers, Ranges

— AND —

Rain Water Goods,

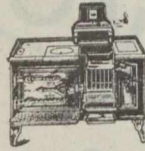

Laurieston Foundry,
FALKIRK, - - Scotland.

THE CANADA SUGAR REFINING CO., Limited, MONTREAL.

Manufacturers of REFINED SUGARS of the well-known
Brand

Redpath

Of the Highest Quality and Purity, made by the Latest Processes, and the Newest and Best Machinery,
not Surpassed anywhere.

LUMP SUGAR, in 50 and 100 lb. boxes.

"CREAM" SUGARS, (not dried).

"CROWN" GRANULATED,

YELLOW SUGARS of all grades and Standards.

Special Brand, the finest which can be made.

SYRUPS of all grades in brls. and half brls.

EXTRA GRANULATED, very Superior Quality.

SOLE MAKERS of high class Syrup
in tins, 2 lb. and 4 lb. each.

At the Office of * * *

The "Journal of Commerce"

You can get everything in the line of

JOB PRINTING.

GIVE US A TRIAL ORDER

BOILER SHOP.

THE STEVENSON BOILER, MACHINE SHOP AND FOUNDRY WORKS AT
PETROLIA, ONT., (now of twenty years' standing), continues to make Marine, Stationary
and Portable Boilers of all kinds. The Canadian Oil Wells and Refiners and Mills in this section are nearly
entirely supplied with Boilers and other Plate Work from this shop; while for well-drilling purposes it
has sent many boilers to Germany, Austria, India and Australia. It also makes Oil Stills, Tanks, Bleachers
and Agitators, Salt Pans, Steam Boxes for Stave and Hoop Mills, and any desired work in Plate or Sheet
Steel or Iron, as well as all productions of Machine Shops, including Steam Engines and Castings in Iron
and Brass.

Having a full outfit of machinery and tools, including Steam Riveter, and men of long experience, it
invites comparison of the quality of its work, with any shop in Canada.

ARTHUR KAVANAGH,

Manager.

J. H. FAIRBANK,

Proprietor.

Telegraphic Address: "PATELLA, PAISLEY."

Paterson, Cooper & Co'y., Ltd.,

Manufacturers of
**Dynamos, Motors,
 Search Lights,
 Arc Lamps,
 Switchboards, Etc.**

Sole Makers of the . . .
**Phoenix Dead Beat Electro-Magnetic
 Ammeters and Voltmeters.**

*Specially suited for Ship Work and Trans-
 mission of Power Circuits.*

Patella Works,
PAISLEY, SCOTLAND.

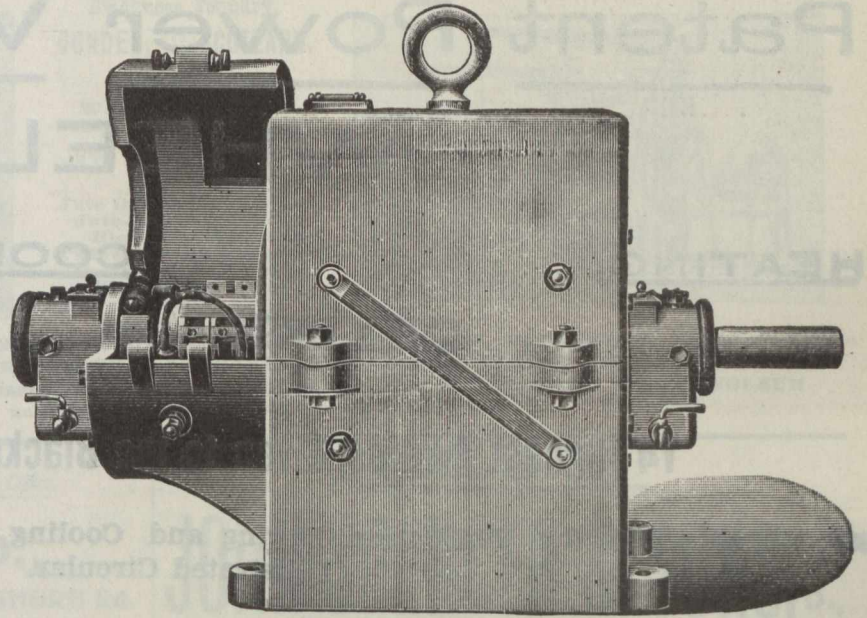

ENCLOSED TYPE MOTOR.

Superior Foot, Power & Turret **LATHES**

For Prices apply to:
**RESIDE, Railway Terrace,
 BRIGHOUSE, Yorks, England.**

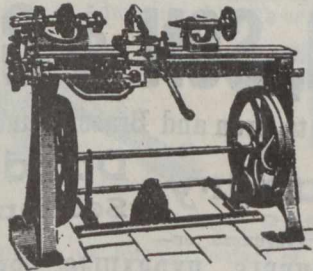

CHUCKS, TAPS AND DIES.

Sim's Patent Casement Window.

Hinged to Open Inward.
 Absolutely Watertight. **JOHN SIM, Architect, MONTROSE, N.B., Scotland.**

Supplied to H.M. Public Works Office Royal National Lifeboat Institution, &c. Diploma, Edinburgh, 1890.
 Diploma & Gold Medal, Paris, 1891. Diploma, Birmingham, 1892.

Absolutely watertight, sash rises and opens inwardly, simple, durable.
 No stay required. Gun metal hinges. With or without springs. Falls
 automatically when closed. Guaranteed five years. Drawings and particu-
 lars on application.

USED FOR LIGHTHOUSES.

PRICE - Fittings from 10s. 6d. per Set

Apply to . . .

JOHN SIM,
 Architect,
MONTROSE, N.B., Scotland.

. . . Or . . .

Messrs. BAIRD, THOMPSON & CO.,
 Sanitary Engineers,
 26 Bath St., - **GLASGOW, Scotland.**

R. & W. Hawthorn, Leslie . . . AND Co., Ltd.

NEWCASTLE-ON-TYNE, ENGLAND.

Manufacturers of

LOCOMOTIVES OF EVERY DESCRIPTION

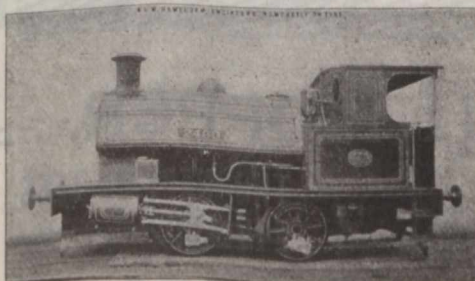

**PHOTOGRAPHS and
 SPECIFICATIONS
 ON APPLICATION.**

Standard Classes in Pro-
 gress and in Stock.

○ ○

*Special prices to Canadians under
 the New Tariff.*

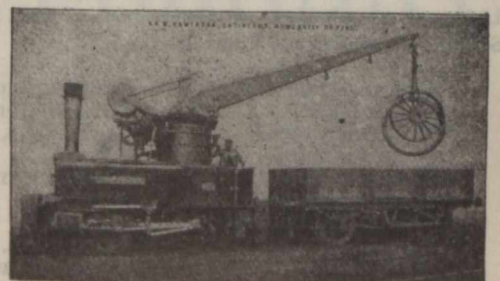

SPECIALITIES. Combined Crane and Locomo-
 tive, Standard Tank Engines, 4 and 8 wheel coupled.

ENQUIRIES cordially invited which will have prompt and
 careful attention.

* **BLACKMAN'S** *

Patent Power Ventilating

* **WHEEL.** *

HEATING.**COOLING.****DRYING.****VENTILATING.**

14 Highest Awards Given to the Blackman Air Propellor.

ESTIMATES for Ventilation, Drying and Cooling given on Application. Send for Illustrated Circular.

MILLER BROS. & TOMS, - Agents, - MONTREAL



The Bellevue Apartments,

On ST. CATHERINE ST., METCALFE ST.
and DOMINION SQUARE,
MONTREAL.

TELEPHONE CALL,
Up 1019.

M. S. FOLEY, Proprietor.

Elegant eight-storey Building, with Artistic Elevation and Three open Courts. The Latest Improvements. Forty-two Apartments, of Five, Six, and Seven rooms each. A few larger Suites of Nine to Thirteen rooms. Thoroughly Fireproof. New, Large, Light (outside). Modern and Airy. Spacious, Handsome Marble Entrance, and Arcade, Steel Elevator. Marble Stairs. Passages Illuminated by Electric Lights. Beautiful View of the Mountain, River, Islands, Dominion Square. Restaurant and Trunk Rooms.

ELECTRIC ELEVATORS,	HALL SERVICE,
STEAM HEAT,	HOT AND COLD WATER,
ELECTRIC LIGHTS,	GAS RANGES,
OPEN PLUMBING,	BATHS,
MOSAIC FLOORS,	MARBLE FOYER,
MARBLE STAIRS,	CUPBOARDS,
CEDAR WARDROBES,	CLOSETS,
MESSENGER CALLS,	TELEPHONE,
BOOK CASES,	REFRIGERATORS,

NO TAXES.

Can be seen daily, Sundays and Evenings. Rents, \$300 to \$600 and upwards. Inspection by permission.

JANITOR ON PREMISES.

THOMSON, SON & Co.,

Engineers, Millwrights, Iron and Brass Founders,
Douglas Foundry, Dundee,
Scotland.

—MANUFACTURERS OF—

TURBINES, WATER WHEELS, HYDRAULIC PRESSES,
Hydraulic Cranes, Hydraulic Lifts,

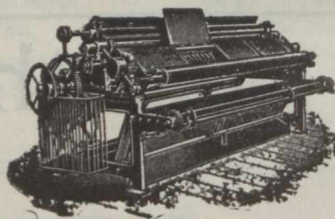

Weaving Machinery for Jute, Calendering Machinery, Mangling Machinery, Saw Mill Machinery, Bleaching Machinery, Heavy Mill Gearing by Wheel Work, Belts or Ropes; Spur, Bevel and Mitre Wheels & Pulleys moulded by Machinery.

CABLE ADDRESS: "HOPPER."



JOHN I. HOPPER, LTD.,

Manufacturers of
Every Description of

**THORNABY-ON-TEES
ENGLAND.**

WIRE ROPES

For Collieries, Mines, & all Hauling & Lifting purposes.

Special prices for Canadian Trade under the New Tariff

TELEGRAPHIC ADDRESS:—"ENGINEERS, DUNDEE."

URQUHART, LINDSAY & CO., Limited,

Engineers, Millwrights and Machine Makers,

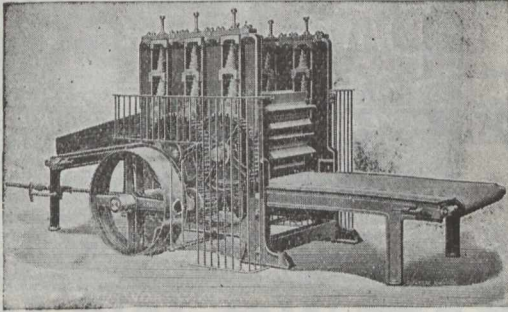

Blackness Foundry,
DUNDEE, - SCOTLAND.

Makers of all kinds of
Weaving and Cloth-
Finishing Machinery for
JUTE & LINEN FABRICS;
INCLUDING
Jute Openers;
Jute Softeners;
Bleaching Machinery
Twine Tarring Machines
Patent Cop and Warp
Winding Machines;
Patent Beaming and
Starbbling Machines;

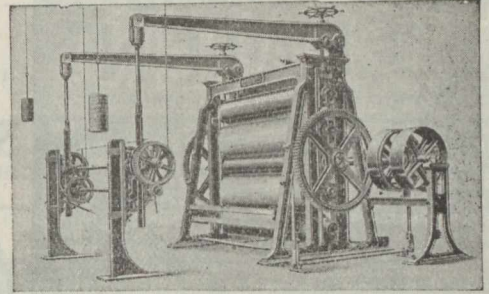

LOOMS of all kinds; Patent **CROPPING MACHINES**; **MEASURING & DAMPING MACHINES**; **CALENDERS**; Patent Hydraulic **CALENDER-MANGLES**; **STRIPPING, CRISPING and LAPPING MACHINES**; **CALENDEROYS, &c.**;
STEAM ENGINES, Shafting, and Gearing; **Cranes, Elevators, Fire-proofing, and other Cast-iron Works**; also, **LINOLEUM MACHINERY**; and **Hydraulic Presses and Pumps of all Sizes.**

Contractors to the British Admiralty and India Office.

H. Charlton & Co.,

SOUTH SHORE Rd.

Engineers & Anchor Manufacturers,

Gateshead-on-Tyne, - England.

Telegraphic Address: "CHARLTON HAWKS, GATESHEAD."

YOU WANT **ANCHORS?**

USE ours, which are of great holding power and moderate cost. Used by British Admiralty, Foreign Governments and the Mercantile Marine. Complete outfits of Chains and Anchors supplied; made to Admiralty, Lloyd's or Bureau Veritas inspection.



YOU WANT **FANS?**

WRITE to us for particulars of the "SIROCCO," which is of high efficiency and moderate cost. Special system of induced and forced draught. If you want more steam from your boilers, or to save coals, write us.

Sole Manufacturers of

... IMPROVED MARTIN'S PATENT ANCHORS ...

For the Improved Martin's Anchor Company, Limited London.

We have orders now in hand for over 300 tons of our Anchors for British Admiralty alone.

Journal of Commerce Job
Department for Printing.

ESTABLISHED 1810.

JOHN SPENCER & SONS, L^TD.,

(Works:—At NEWBURN and OUSEBURN, NEWCASTLE-ON-TYNE),

Newburn Steel Works,

NEWCASTLE-ON-TYNE, ENGLAND,

Offices: { Newcastle-on-Tyne: 27 Westgate Road,
London: Cannon Street Buildings, 139 Cannon Street.

ON ADMIRALTY LIST.

MANUFACTURERS OF STEEL

By the Siemens' Cementation, and Crucible Processes.

SHIP and BOILER PLATES up to 11 Feet Wide.

Ingots, Slabs, Blooms, Billets, and Bars of all sizes.

Rivet Steel. Special Mild Steel for Boiler Flues.

STEEL FORGINGS, STEEL CASTINGS,

Of all descriptions, to any weight, Rough or Machined.
CRANK AXLES & SHAFTING HYDRAULIC PRESSED.

Springs.—Laminated, Volute, Patent Improved Volute, Conical, Spiral (Original Manufacturers of Volute Springs).

Buffers, of Wrought and Cast Iron, of all descriptions. Best Cast Steel for Tools from finest Dannemora Brands. Best Cast Steel Files. **IRON FORGINGS** of all kinds.

FOSTER'S & FOWNES' Patent CRANK SHAFTS.

WASTENEYS SMITH'S PATENT STOCKLESS ANCHORS,

Special price to Canadians under the New Tariff.

THE ROSE STREET FOUNDRY

and Engineering Company, Limited,

+ ROSE STREET, +

INVERNESS, - - Scotland.

—MANUFACTURERS OF—

RAILWAY CHAIRS, GRATES, FENDERS

— Etc., Etc. —

TAYLOR'S PATENT

CONTRACTORS TO THE ADMIRALTY

THE ATTENTION OF ENGINEERS & OTHERS IS SOLICITED TO THE PRINCIPLES OF OUR UNIQUE PACKING, THIS PACKING CONSISTS OF METAL RINGS OBLONGS, & SQUARES, CUT FROM THIN SHEETS OF BRASS, & CORRUGATED; FOR THE PURPOSE OF BEING PLACED IN JOINTS IN THE JOINING OF METAL PIPES. MAKING JOINTS STEAM & WATER-TIGHT, IN MAKING JOINT CORRUGATED THE RING IS LAID WITH CEMENT ON INNER PART OF FLANG, CLEAR OF BOLTS, IN CREWING UP JOINT, RIDGES OF CORRUGATIONS YIELDING TO IT WILL TAKE IMPRESSIONS OF IRREGULARITIES OF SURFACES OF FLANGES, MAKING IT IMPOSSIBLE FOR HIGH PRESSURE FROM STEAM OR WATER TO ENTER JOINT.

SOLE MAKERS NEWTON TYNE DOCK CORRUGATED PACKING WORKS



METALLIC PACKING.

& SPANISH ROYAL NAVAL COMMISSION

SOME ADVANTAGES OF THIS PACKING ARE:
 1- CHEAPNESS; NO CUTTING OF HOLES TO MAKE. COST OF RINGS BEING A TRIFLE COMPARED WITH IMPORTANCE OF HAVING A GOOD JOINT.
 2- THIS PACKING IS SUITABLE FOR HEAT PETROLEUM BOILER STAYS ETC.
 3- BY USING RINGS TIGHT JOINT CAN BE MADE WITH GREAT CERTAINTY.
 4- WITH THIS PACKING A CLOSE NEAT JOINT CAN BE MADE.

THESE RINGS MANUFACTURED IN BRASS COPPER GUN METAL & STEEL

& NICHOLSON SOUTH SHIELDS

ANDERSON BROS.,

Engineers and Manufacturers,

Crown Smith Works, COATBRIDGE, SCOTLAND.

Iron and Steel Roofing, Coal Screening Plant,
 Revolving Hutch Tippers,
 Cadzow Hand Adjustable Coal Picking Bands.

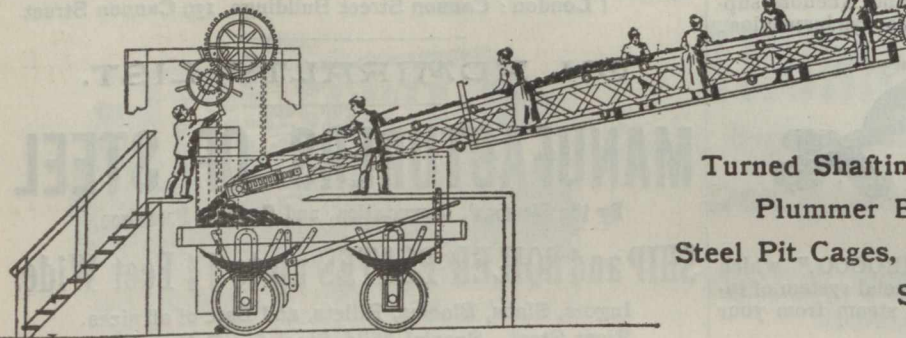
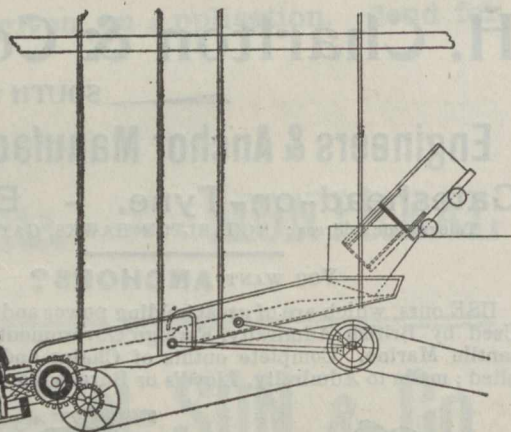

Turned Shafting, Sinking Kettles,
 Plummer Blocks, Cellar Hoists,
 Steel Pit Cages, Steel Hutches,
 Smith Forgings, &c.

L. WRIGHT & SON,

WRIGHT'S CELEBRATED NAVY BISCUITS.

These Biscuits are made from Pure Wheaten Flour, Thoroughly Kiln-Dried and specially prepared for long voyages, and are of World-Wide renown.

Established over 100 Years.

Manufactory: East Holborn; Offices: Dean Street,
 SOUTH SHIELDS,
 ENGLAND.

AMOS COWEN,

Builder & Contractor

294 Peel Street,
 MONTREAL, Que.

Insurance.

The Federal Life ASSURANCE COMPANY.

HEAD OFFICE, HAMILTON, CANADA.

Capital and Assets - - - - \$2,149,055.92
 Surplus to Policyholders - - - 1,025,317.85
 Paid Policyholders in 1900 - - - 170,813.58

MOST DESIRABLE POLICY CONTRACTS.

IAS. H. BEATTY, President. DAVID DEXTER, Managing Director.
 J. K. McCUTCHEON, Sup't. of Agencies.
 H. RUSSELL POPHAM, Provincial Manager.

THE BEST COMPANY FOR THE BEST RISKS.

THE

Manufacturers and Temperance and General Life Assurance Company.

Business in Force, over - - \$26,000,000 00
 Total Assets, about - - - - 3,500,000.00

Hon. G. W. ROSS, President. J. F. JUNKIN, Managing Director.

SEPARATE CLASSIFICATION FOR TOTAL ABSTAINERS.

Scottish Union and National INSURANCE COMPANY,
 Of Edinburgh, Scotland.

ESTABLISHED 1824.

M. BENNETT, Jr., Gen. Manager North American Branch, Hartford, Conn.
 Capital\$30,000,000 | Invested Funds.....\$13,500,000
 Total Assets 34,472,705 | Deposited with Dom. Govt., 125,000
 (Market value.)

WALTER KAVANAGH, Resident Agent, 117 St. Francois Xavier St., MONTREAL

Insurance.

British * America ASSURANCE COMPANY.

HEAD OFFICE, - - - TORONTO,

Incorporated 1833.

FIRE AND MARINE.

Cash Capital, \$1,000,000 00
 Assets, \$1,776,606 45
 Losses Paid since organization. . . \$19,946 517.73

Geo. A. Cox, President. J. J. KENNY, Vice-Pres. P. H. SIMS, Secretary
 C. R. G. JOHNSON, Res. Agent, 1723 Notre Dame St., MONTREAL.

The Mutual Life INSURANCE COMPANY

OF NEW YORK.

RICHARD A. McCURDY, President.

STATEMENT FOR THE YEAR ENDING DEC'EMBER 31st, 1896

Assets, - \$184,935,690.80

Reserve on Policies (American Table, 4 p.c.)..... \$168,221,916
 Liabilities other than Reserve 1,622,951
 Surplus..... 15,089,822
 Receipts from all sources 41,953,145
 Payments to Policy holders..... 20,885,472
 Whole Life Risks assumed and renewed, 219,318 policies 637,726,276
 Risks in force : 273,213 policies, amounting to..... 801,867,478

NOTE.—The above statement shows a large increase over the business of 892 in amount at risk, new business assumed, payments to policy-holders, receipts, assets and surplus; and includes as risks assumed only the number and amount of policies actually issued and paid for in the accounts of the year

AGENTS WANTED. Apply to

FAYETTE BROWN, Manager, MONTREAL.

(FOUNDED 1825.)

Law Union & Crown Ins. Co.,

(OF LONDON.)

Assets exceed, - - - \$22,000,000.

Fire risks accepted on most every description of insurable property.

Canadian Head Office: BEAVER HALL, MONTREAL

J. E. E. DICKSON, Manager.

Agents Wanted throughout Canada.

THE NORTH AMERICAN LIFE ASSURANCE COMPANY.

Head Office: 112-118 King St. West, TORONTO, Ont.

The following figures taken from the last financial statement show the unexcelled financial position to which the Company has attained. It has

Assets\$ 3,977,263.83
 Cash Income..... 1,005,970.55
 Net Surplus..... 500,192.49
 Insurance in Force..... 25,575,142.00

L. GOLDMAN, Secretary. WM. McCABE, Man. Dir.

Messrs. AULT and McCONKEY, Managers for Province of Quebec, 180 St. James St., Montreal.

Saxe & Archibald, ARCHITECTS
 Room 79, Imperial Building, MONTREAL.

OILS.

The IMPERIAL OIL COMPANY, Ltd.

—REFINERS AND MANUFACTURERS OF—

CANADIAN PETROLEUM PRODUCTS,

Under New Patent Process

Refined Oils, Benzine, Napthas and Gasolenes, Lubricating Oils, Greases Paraffine Wax Candles, Fuel Oils, &c.

Refineries: SARNIA and PETROLIA, Ont.

Branches:

MONTREAL, P.Q. ST. JOHN, N.B. HALIFAX, N.S. WINNIPEG, Man. VANCOUVER, B.C.

—SELLING AGENTS FOR PROVINCE OF ONTARIO—

The QUEEN CITY OIL COMPANY, Limited,

Head Office: TORONTO, Ont.

Branches: OTTAWA, HAMILTON, LONDON, KINGSTON, and other Stations Province of Ontario.

NEW YORK LIFE

INSURANCE COMPANY.

JOHN A. McCALL, President;

Gain in Insurance in force 1900
\$140,000,000

AN UNPARALLELED RECORD.

Applications invited by the undersigned for general and special agencies, and management of territory from experienced Life Insurance men, as well as from those wishing to acquire training and experience.

WESTERN CAN. BR., 496 1/2 Main St., Winnipeg, Man.
N. B. BR., 120 Prince William St., St. John, N. B.
TORONTO BRANCH, 6 King St., West, Toronto, Ont.
HALIFAX BR., Barrington and Prince Sts.

R. HOPE ATKINSON.

AGENCY DIRECTOR,

Company's Building, MONTREAL

J. DUNCAN DAVISON

Imperial Bdg. 107 St. James Street,
Montreal.

COMMISSIONER

For Following Provinces:

Ontario, Quebec, Manitoba, New Brunswick
Nova Scotia and Prince Edward Island.

LIVERPOOL & LONDON & GLOBE

INSURANCE COMPANY.

Available Assets, - - \$58,553,900

Funds Invested in Canada, - \$2,110,000

Security, Prompt Payment and Liberality in the adjustment of Losses are the prominent features of this Company.

Canada Board of Directors:

EDMOND J. BARBEAU, Chairman.

WENTWORTH J. BUCHANAN, Deputy Chairman.

A. F. GAULT, SAML. FINLEY, E. S. CLOUSTON.

G. F. C. SMITH, Resident Secretary.

Head Office, Canada Branch:

MONTREAL.

THE WATERLOO MUTUAL

Fire Insurance Company.

Established in 1863. Head Office, Waterloo, Ont.

Total Assets, Jan. 1, '94, \$349,734.71.

GEORGE RANDALL, Esq., President; JOHN SHUH, Esq., Vice President; Frank Haight, Esq., Manager; John Killer, Esq., Inspector.

UNCONDITIONAL POLICIES

ARE ISSUED BY THE . . .

CONFEDERATION LIFE ASSOCIATION.

Cash Values,
Extended Insurance,
Paid up Policies,
GUARANTEED.

Full information sent on application.

H. J. JOHNSTON,

Prov. Manager,

174 ST. JAMES ST.,
MONTREAL.

W. C. MACDONALD,

Actuary.

J. K. MACDONALD.

Managing Director.

Head Office, - TORONTO.

Royal-Victoria Life Insurance Company.

CAPITAL, - - \$1,000,000.

HEAD OFFICE:

MONTREAL.

INCREASE IN BUSINESS IN 1900, COMPARED WITH 1899.

Interest.....	\$ 9,001.79
Premiums	86,416.79
Total Cash Income	95,420.47
Reserves, Government Standard	120,638.21
Insurance in Force.....	2,116,880.00

Increase over 1899.....	20 per cent.
Increase over 1899.....	42 "
Increase over 1899.....	40 "
Increase over 1899.....	70 "
Increase over 1899.....	24 "

DEPOSITED with the Canadian Government for the protection of Policy-holders, \$100,000.

DAVID BURKE, A.I.A., F.S.S.,
General Manager.

The Canada Accident Assurance Company.

Head Office, MONTREAL.

A Canadian Company for Canadian Business

ACCIDENT AND PLATE GLASS.

Surplus 50 p.c. of Paid-Up Capital above all liabilities including Capital Stock

T. H. HUDSON, Manager, **R. WILSON SMITH,** President

WESTERN ASSURANCE COMPANY.

FIRE AND MARINE. Incorporated 1851.

Assets, over \$2,925,000.00
Annual Income, 2,994,000.00

Head Office. - Toronto. Ont.

Hon. GEO. COX, Pres. J. J. KENNY Vice-Pres. & Man.-Dir
C. C. FOSTER, Secretary.

Montreal Branch, - 189 ST. JAMES STREET.

ROBT. BICKERDIKE, Manager.

ROUTH & CHARLTON, City Agents.

THE IMPERIAL INSURANCE COMPANY LIMITED

FIRE.

LONDON.

ESTABLISHED 1808.

SUBSCRIBED CAPITAL, \$6,000,000
PAID-UP CAPITAL, 1,500,000
TOTAL INVESTED FUNDS OVER 8,000,000

Canadian Branch:

COMPANY'S BUILDING, PLACE D'ARMES, MONTREAL.
G. R. KEARLEY, RESIDENT MANAGER.

NATIONAL ASSURANCE COMPANY

OF IRELAND.

ESTABLISHED 1822.

Capital Fully Subscribed, - \$5,000,000.

Canadian Branch:

Trafalgar Chambers, - 22 St. John Street, Montreal.

H. M. LAMBERT, MANAGER.

DISTINCTIVE QUALITIES

—OF—

North Star, Crescent and Pearl Batting.

Purity, Brightness, Loftiness.

No Dead Stock, oily threads nor miserable yellow fillings of short staple. Not even in lowest grades. Three grades—Three prices and far the best for the price.

COMMERCIAL UNION ASSURANCE CO., Ltd.

Of London, England.

FIRE LIFE MARINE

Agencies in all the principal Cities and Towns of the Dominion.

HEAD OFFICE, Canadian Branch, - MONTREAL.
JAMES MCGREGOR Manager.