

**CIHM  
Microfiche  
Series  
(Monographs)**

**ICMH  
Collection de  
microfiches  
(monographies)**



**Canadian Institute for Historical Microreproductions / Institut canadien de microreproductions historiques**

**© 1995**

Technical and Bibliographic Notes / Notes techniques et bibliographiques

The Institute has attempted to obtain the best original copy available for filming. Features of this copy which may be bibliographically unique, which may alter any of the images in the reproduction, or which may significantly change the usual method of filming, are checked below.

L'Institut a microfilmé le meilleur exemplaire qu'il lui a été possible de se procurer. Les détails de cet exemplaire qui sont peut-être uniques du point de vue bibliographique, qui peuvent modifier une image reproduite, ou qui peuvent exiger une modification dans la méthode normale de filmage sont indiqués ci-dessous.

Coloured covers/  
Couverture de couleur

Covers damaged/  
Couverture endommagée

Covers restored and/or laminated/  
Couverture restaurée et/ou pelliculée

Cover title missing/  
Le titre de couverture manque

Coloured maps/  
Cartes géographiques en couleur

Coloured ink (i.e. other than blue or black)/  
Encre de couleur (i.e. autre que bleue ou noire)

Coloured plates and/or illustrations/  
Planches et/ou illustrations en couleur

Bound with other material/  
Relié avec d'autres documents

Tight binding may cause shadows or distortion  
along interior margin/  
La reliure serrée peut causer de l'ombre ou de la  
distorsion le long de la marge intérieure

Blank leaves added during restoration may appear  
within the text. Whenever possible, these have  
been omitted from filming/  
Il se peut que certaines pages blanches ajoutées  
lors d'une restauration apparaissent dans le texte,  
mais, lorsque cela était possible, ces pages n'ont  
pas été filmées.

Additional comments:/  
Commentaires supplémentaires:

Coloured pages/  
Pages de couleur

Pages damaged/  
Pages endommagées

Pages restored and/or laminated/  
Pages restaurées et/ou pelliculées

Pages discoloured, stained or foxed/  
Pages décolorées, tachetées ou piquées

Pages detached/  
Pages détachées

Showthrough/  
Transparence

Quality of print varies/  
Qualité inégale de l'impression

Continuous pagination/  
Pagination continue

Includes index(es)/  
Comprend un (des) index

Title on header taken from:/  
Le titre de l'en-tête provient:

Title page of issue/  
Page de titre de la livraison

Caption of issue/  
Titre de départ de la livraison

Masthead/  
Général (périodiques) de la livraison

This item is filmed at the reduction ratio checked below/  
Ce document est filmé au taux de réduction indiqué ci-dessous.

10X	12X	14X	16X	18X	20X	22X	24X	26X	28X	30X	32X
						/					

The copy filmed here has been reproduced thanks to the generosity of:

National Library of Canada

The images appearing here are the best quality possible considering the condition and legibility of the original copy and in keeping with the filming contract specifications.

Original copies in printed paper covers are filmed beginning with the front cover and ending on the last page with a printed or illustrated impression, or the back cover when appropriate. All other original copies are filmed beginning on the first page with a printed or illustrated impression, and ending on the last page with a printed or illustrated impression.

The last recorded frame on each microfiche shell contains the symbol  $\rightarrow$  (meaning "CONTINUED"), or the symbol  $\nabla$  (meaning "END"), whichever applies.

Maps, plates, charts, etc., may be filmed at different reduction ratios. Those too large to be entirely included in one exposure are filmed beginning in the upper left hand corner, left to right and top to bottom, as many frames as required. The following diagrams illustrate the method:

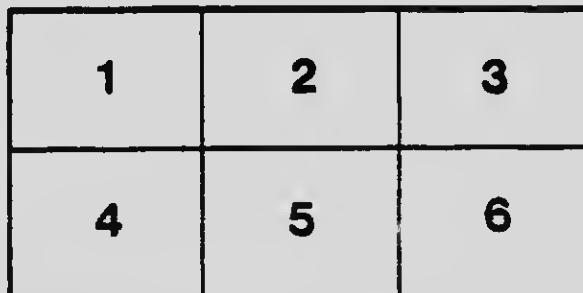
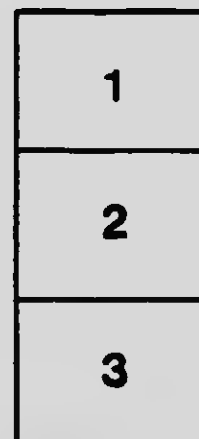
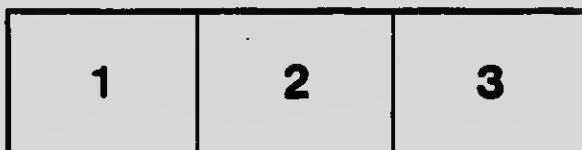

L'exemplaire filmé fut reproduit grâce à la générosité de:

Bibliothèque nationale du Canada

Les images suivantes ont été reproduites avec le plus grand soin, compte tenu de la condition et de la netteté de l'exemplaire filmé, et en conformité avec les conditions du contrat de filmage.

Les exemplaires originaux dont la couverture en papier est imprimée sont filmés en commençant par le premier plat et en terminant soit par la dernière page qui comporte une empreinte d'impression ou d'illustration, soit par le second plat, selon la cas. Tous les autres exemplaires originaux sont filmés en commençant par la première page qui comporte une empreinte d'impression ou d'illustration et en terminant par la dernière page qui comporte une telle empreinte.

Un des symboles suivants apparaît sur la dernière image de chaque microfiche, selon le cas: le symbole  $\rightarrow$  signifie "A SUIVRE", le symbole  $\nabla$  signifie "FIN".

Les cartes, planches, tableaux, etc., pouvant être filmés à des taux de réduction différents. Lorsque le document est trop grand pour être reproduit en un seul cliché, il est filmé à partir de l'angle supérieur gauche, de gauche à droite, et de haut en bas, en prenant le nombre d'images nécessaire. Les diagrammes suivants illustrent la méthode.

# MICROCOPY RESOLUTION TEST CHART

(ANSI and ISO TEST CHART No. 2)

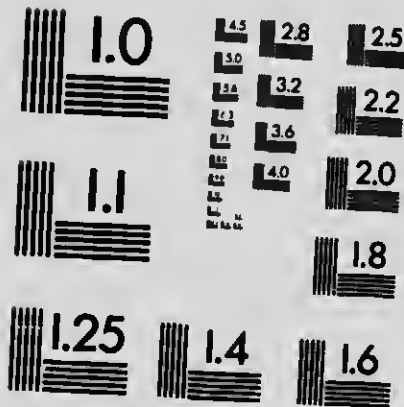

**APPLIED IMAGE Inc**

1853 East Main Street  
Rochester, New York 14609 USA  
(716) 482 - 0300 - Phone  
(716) 288 - 5989 - Fax

# HOW TO BUILD RURAL TELEPHONE LINES



111 2000  
1177  
200

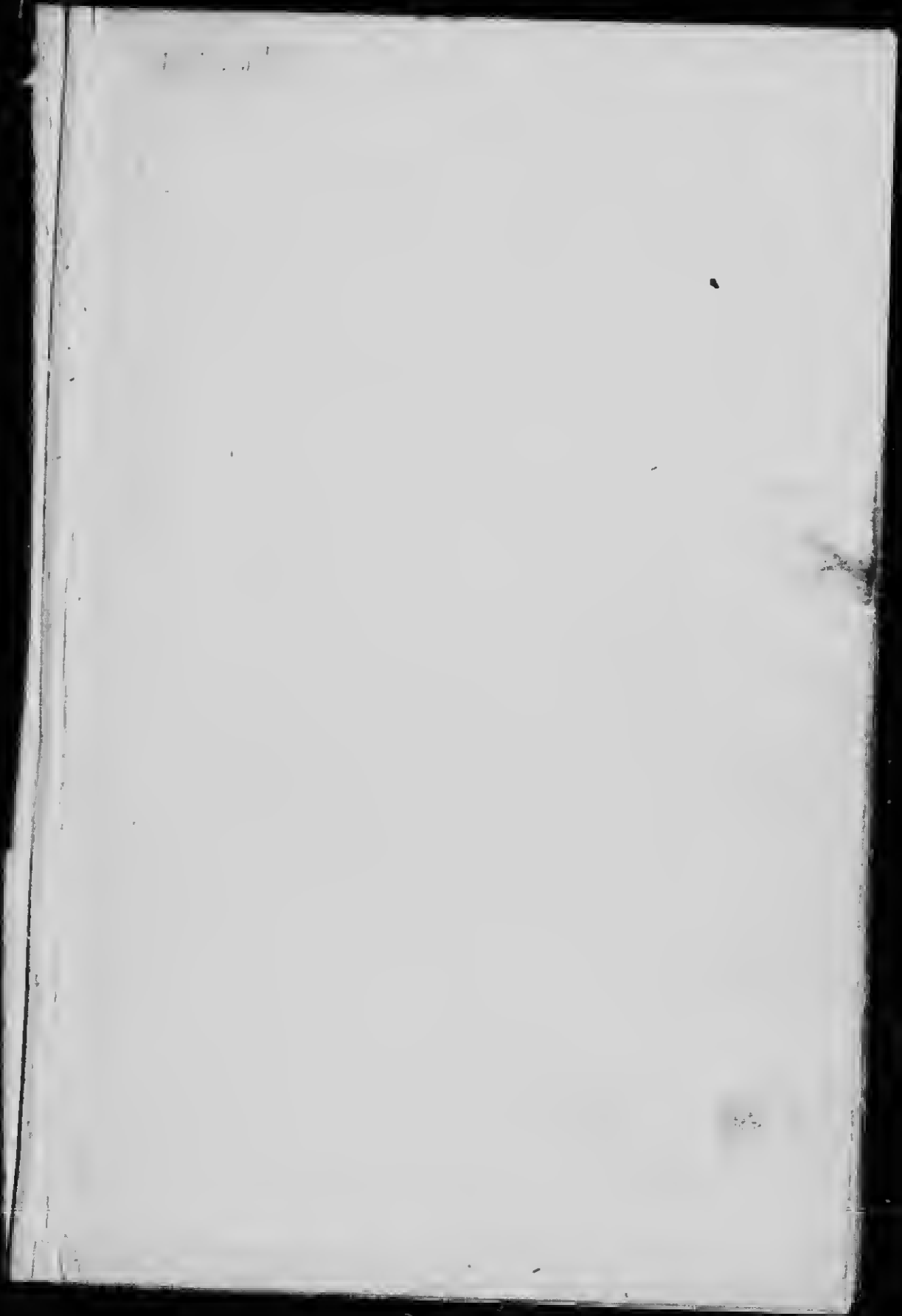











WHERE "NORTHERN ELECTRIC" TELEPHONES ARE MADE



HOW TO BUILD  
== RURAL ==  
TELEPHONE LINES



PUBLISHED BY

The  
Northern Electric & Mfg. Co.  
Limited

MONTREAL  
CALGARY

TORONTO  
REGINA

WINNIPEG  
VANCOUVER

TK9951

N67

1910

COPYRIGHT 1910 BY  
THE NORTHERN ELECTRIC & MFG. CO.  
LIMITED

# CONTENTS

CHAPTER	PAGE
I.—Story of the Telephone—Invention— Early Experiments—Present Situation —Value to farmer—Comments of the Press - - - - -	7-23
II.—Company Organization—Mutual and Stock Companies — Constitution and By-laws — Construction — Survey of Toll Lines - - - - -	24-35
III.—Constructing the Line—Different Sys- tems—Poles and fittings—Setting the Poles — Guying—Line Wire and Stringing—Splicing—Insulation -	36-56
IV.—Installing the Instruments—Connecting to the Line—Protectors—Drop Wires Inside Wiring—Ground Wires—Bat- teries—How to use the Telephone— Signals - - - - -	57-65
V.—Materials Required—For Main Line —For Each Telephone Station -	66-68
VI.—The 1317 Type Telephone Set— New Features—Woodwork and As- sembly—Transmitter—Receiver—Ring- ers and Gongs—Generator—Switch Hook—General—Specifications -	69-78
VII.—Rules for Wires Crossing Railways— General Order of Canadian Board of Railway Commissioners—Dated Oct. 7th, 1909—Signed by Hon. J. P. Mabee, Chief Commissioner - -	79-93

DEDICATED TO  
THE PROGRESSIVE CANADIAN  
FARMER

# How to Build Rural Telephone Lines

---

## CHAPTER I.

*Story of the Telephone—Invention—Early Experiments—Present Situation—Value to Farmer—Comments of the Press.*

**I**N this prosaic age of cold facts, the history of a "toy" that became a billion dollar business and that proved itself to be one of the most wonderful factors for civilization that the world has ever known, is a story that cannot fail to interest everyone. How the telephone, scoffed at and derided as a "scientific toy," has developed into a vital tool of commerce, would, if our great-grandfathers could but hear it, sound to them like the dream of a visionary.

In 1877, an editorial writer referred to Prof. Alexander Graham Bell, the then young elocutionist who had invented the "talking telegraph," as "a crank who says he can talk through a wire!"

And—think of it—this was but little more than thirty years ago. It seems hard to realize but it was in the lifetime of most of us that the great London *Times* alluded pompously to the telephone as "the latest American humbug."

To-day this "scientific toy"—this derided plaything



## HOW TO BUILD RURAL TELEPHONE LINES

of fanatics and dreamers—is backed up by a capital of a billion dollars, carries as many messages as the combined post office departments of the world, brings into contact fourteen billion people each year, employs a hundred thousand workers, girds the country with enough wire to string forty-four strands to the moon and is the most indispensable single machine in the service of mankind.

In 1876, although the telephone may have been but a "scientific toy," it was also an established scientific fact. Possibly in nothing, more than in the telephone, has been exemplified the truth of the statement that "facts are stubborn things." Invented in Brantford, Ont., by a speech specialist who discovered it by combining the science of sound with electricity, baptized by the patent office, given a royal reception at the Philadelphia Centennial and followed by world-wide publicity, it might be supposed that the telephone would immediately work a wonderful revolution in affairs. But such was not the case; the commercial world took no notice of it—as yet, it belonged to the realms of science only. It would never be a practical necessity, said business men.

### *HOW BELL WAS RIDICULED.*

Instead of being applauded, Bell was pelted with a storm of ridicule. He was called an imposter and a crank. The greatest newspapers in the world indulged in many profound reasons to show that speech could not be sent over a wire because of the intermittent nature of the current. Even though he came late in

THE NORTHERN ELECTRIC & MFG. CO., LTD.

the succession of inventors, Bell had to run the gauntlet of scoffing and adversity. From the reception that the world gave to the telephone, he must have learned to sympathize with Howe, whose first sewing machine was smashed by a Boston Mob; with McCormick, whose first reaper was called "a cross between an Astley chariot, a wheelbarrow and a flying machine"; with Morse, whom ten Congresses regarded as a nuisance; with Cyrus Field, whose Atlantic cable was denounced as "a mad freak of stubborn ignorance," and with Westinghouse, the inventor of the air-brake, who was called a fool for proposing to stop a railroad train with wind. No one could understand the telephone or how it worked; the only man who offered a clear solution of the mystery was a Boston mechanic, who maintained that "there was a hole through the middle of the wire!"

In these almost recent days, very few men had sufficient imagination to picture the telephone as a part of their daily existence—as a part of their business and social life. The banker said it might do well enough for grocers; but it would never be of any value in banking. The grocer said it might be all very well for bankers to use telephones, but, so far as grocers were concerned, telephones would never be of very much use.

To-day, with the telephone looked upon by everyone as a necessity, how Prof. Bell must smile to himself over these wise men's ultimatums—how he must laugh at the telephone ever having been described as a "toy."

## HOW TO BUILD RURAL TELEPHONE LINES

### EARLY EXPERIMENTS.

The introduction of the telephone was by no means an easy task and the load of missionary work that Prof. Bell assumed might have daunted many a more determined man. It is almost ludicrous now to look back upon the semi-circus methods that were adopted to call the attention of the world to the telephone. For instance, a telegraph wire between New York and Boston was borrowed for half an hour and, in the presence of Sir William Thomson, Bell sent a tune over the two hundred and fifty mile line.

"Can you hear?" Bell asked the operator at the New York end.

"Elegantly," responded the operator.

"What tune?" he questioned.

"Home, Sweet Home." came the answer.

Shortly afterward, while Bell was visiting at his father's home in Canada, he bought up all the stove-pipe wire in the town and tacked it to a rail fence between the house and a telegraph office. Then he went to a village eight miles distant and, over the telegraph wire and the stove-pipe wire combined, he sent home scraps of song and Shakspearian quotations.

Later, a telegraph wire between Boston and Cambridge Observatory was borrowed and a telephone was attached to each end. For three hours or longer over this wire, the first sustained telephone conversation was held. Careful notes of what was said were taken at each end. These notes published, side by side in parallel columns in the *Boston Advertiser* of October

## THE NORTHERN ELECTRIC & MFG. CO., LTD.

19th, 1876, proved beyond question that the telephone was now a practical success.

### *FIRST LEASED TELEPHONE.*

In the month of May, 1877, a man named Emery in the city of Charleston leased two telephones for \$20.00 in actual cash—the first real money ever paid for a telephone. By August, when Bell's patents were sixteen months old, there were seven hundred and seventy-eight telephones in use, and Bell, with three associates named Hubbard, Saunders and Watson, formed what was known as the "Bell Telephone Association." There was no capital—there was none to be had! These four men had, at that time, an absolute monopoly of the telephone business—and everyone else was quite willing that they should have it.

Contrast the telephone situation of thirty years ago with the way in which the instrument is regarded today. The number of instruments now in use probably runs into the millions, and stock in telephone companies which at that time went begging for purchasers now commands a high premium. Bankers and grocers alike both have telephones and would not be without them for anything.

### *THE RURAL TELEPHONE.*

For years, however, telephone organization in Canada rarely extended beyond the cities and towns. The attitude of the farmer was very much like the early ideas of the banker and the groceryman; the telephone was all right for city dwellers, but unnecessary on the farm! It is wonderful to note how this feeling has

## HOW TO BUILD RURAL TELEPHONE LINES

changed within the last decade. To anyone who travels the country roads, one of the most striking features is the continuous evidence of the growth of the rural telephone. Even the most remote and sparsely settled parts of the country have their strings of wired poles, spreading like a network along highway and by-way and branching off, here and there, to some farmhouse which, were it not for the connecting link of the magic wire, would indeed be isolated.

The call of the telephone bell is no uncommon sound in the farmhouse to-day. Men are called for the threshing, prices are learned, buying and selling is done, orders go to the butcher and the grocer, and friendly gossip and chat are all among the many things that keep the busy rural lines buzzing. The farmer with a telephone is no more isolated than his brother in the city—indeed, often far less so; for the city man as a rule does not know his next door neighbor. The farmer knows everybody, and, thanks to the wonderful invention of Prof. Graham Bell, can talk to them all, any minute of the day or night. To comment on the value of the telephone to the farmer, from the standpoint of prices and markets, would be almost superfluous when one considers to how great an extent the instrument is used for just this purpose.

Most of these rural telephone systems are independent concerns owned among the subscribers themselves, and, consequently the running expenses are low—merely the cost of maintaining the plant and the salary of a girl at Central. Inasmuch as these rural telephone

THE NORTHERN ELECTRIC & MFG. CO., LTD.

systems are put up almost entirely by the men who own them, the cost of their installation is very little. Further on in this book, all the facts that one requires are given fully and in detail.

*SOME INSTANCES.*

For the reader who desires more detailed information about the actual workings of some of these co-operative companies which have been organized and which are successfully doing business to-day, the following pages will prove of interest. These extracts are clipped from various newspapers which have described the workings of rural telephone companies in their own communities—and, by the way, it is interesting to note that the equipment in all of these companies has been supplied by the Northern Electric and Manufacturing Company, which, indeed, has manufactured ninety per cent. of all the telephones used in Canada to-day.

Under the title of "The Rural Telephone," the *Toronto Canadian Farm*, in its issue of Oct. 8th, 1909, has the following editorial:

"Nothing in recent years has done more to improve the farmer's position than the telephone. The system in use is one that the farmer controls and operates himself, or may do so if he wishes. A local company is formed, with a small capital, the poles are erected, the wires are strung, the phones are purchased, and there you are; a complete system with a central office—and the farmer can converse with his neighbor, or he can call up the doctor, the butcher, the grocer, or anyone

THE NORTHERN ELECTRIC & MFG. CO., LTD.

else on circuit or within reach by long distance connection. All rural 'phone companies can have long distance connection if they wish it. The service thus becomes of the greatest possible value, and no 'phone user benefits more from it than the farmer. With a 'phone in his house, he is no longer isolated. He can, in a moment, get in touch with things in the outside world. His horizon is widened, his vision broadened, and the isolation of farm life removed. There should be a telephone in every farm home.

"On the general plan which has been adopted, about 16,000 farmers in Ontario and Quebec are providing telephone service for themselves, not to say anything of the thousands in the West. They receive connection through the Bell system with their home town and local market, as well as with the long distance service of this company. The cost of the service is a mere bagatelle as compared with its benefits. Those who form local companies and install farm 'phones, make money out of it. In one district in western Ontario, a few enterprising farmers decided to have a 'phone system installed. A company was formed. Less than \$1,000 was needed to put up the poles, string the wires and purchase the 'phones and equip the system in the most up-to-date fashion. That company has to-day 62 subscribers at \$10 each, and receives a gross revenue of \$620 a year on its investment. The expense of operation is comparatively small. The rural 'phone is, therefore, a good thing for the farmer who uses it, and also for the fellow who invests his money in the local company controlling it."

THE NORTHERN ELECTRIC & MFG. CO., LTD.

**DEVELOPMENT OF RURAL LINES.**

Commenting on the development of rural lines in Ontario, the *Toronto Weekly Sun* of November 10th, 1909, says:

"An arrangement has been completed with the Wroxeter Rural Telephone Co., covering connection with the Bell at Wroxeter on the toll basis. The townships of Howick, Turnberry, Grey and Morris are being developed and already 125 subscribers are connected.

"A contract has also been made with the North Huron Telephone Co., covering flat rate connection with Wingham.

"Glengarry Co-operative Telephone Association will connect with the Bell system at Alexandria, Dalkeith and Dunvegan. This line extends from the town of Alexandria to Fassifern, to Lochiel, McCrimmon, Laggan, Kirk Hill, Glen Sandfield, Brodie, Skye, Dalkeith and Dunvegan, in the townships of Lochiel and Kenyon. Sixty subscribers are already connected.

"The municipalities of East and West Dover are constructing a system which will connect with the Bell and provide an exchange of service with Chatham subscribers.

"The Dufferin Association have extended their system to the villages of Jessopville, Kelden, McWhirter's, Wesley, Monticello, and throughout the townships of Amaranth, East Luther, and Melancthon. This has connection with the Bell and an exchange of service with Shelburne subscribers.



## HOW TO BUILD RURAL TELEPHONE LINES

"The Chatsworth Company intends constructing a service throughout the township of Holland, which will connect with the Bell at Chatsworth.

"A contract has been made by the Bell with M. C. Morgan, for connection with his rural telephone system at Strathroy. He will develop the township of Adelaide, in Middlesex county, and will connect with twenty-five subscribers.

"Wiarion and Lake Charles Association extends from the village of Wiarion to North Keppel, Kemple Post.

"Construction of a system has commenced which will cover the townships of Napean, Goulburn, Huntley and March, in Carleton county, which will connect with the Bell at Ottawa.

"Development of the service throughout New Ontario is being rapidly carried on, the Bell Company is extending its long distance system from North Bay to Sudbury. A local exchange is to be opened at Chelmsford."

### *ANOTHER SUCCESSFUL COMPANY.*

The *Ottawa Valley Journal* in its issue of October 19th, 1909, states:

"The extension of the rural telephone goes on apace in Carleton County, as may be gathered from the following account of the Monk Rural Telephone Company furnished by Dr. G. H. Groves, of Carp. Dr. Groves is secretary-treasurer and managing-director of the Monk Rural Telephone Company.

THE NORTHERN ELECTRIC & MFG. CO., LTD.

"A year ago last August, said Dr. Groves, Messrs. G. Monk, Robt. Richardson, W. Richardson, J. M. Argue and himself combined together to establish a private telephone line, nine miles, from Carp to South March, with the intention of extending it if circumstances demanded or warranted doing so. The patrons of the line paid \$12.00 rental and the system worked well. But it was a private venture and not on the rural system, and consequently did not bring the farmers in sufficiently.

"It was then decided to start a real rural system and at a meeting held last March, the project was launched and a joint stock company formed under the title of the Monk Rural Telephone Company, Limited. At the very first meeting of the directors of the Monk Rural Telephone Company, many farmers came forward and signed for stock, and the enterprise has been a conspicuous success from the beginning.

"On the day of the meeting mentioned, the 17th of March, 1909, the newly formed company was operating only 27 'phones; before the season closes it will have on its circuits 150 'phones. At Marchhurst, in two miles and a half, the system has twelve subscribers. The work has been carried on systematically. When a sufficient number of subscribers has been obtained on one particular route, the line is erected and the 'phones are put in. The management requires two shareholders to the mile before starting any one line. Carp is Central and has a switchboard for sixty lines.

"The Monk Rural Telephone System connects the following places: Carp, as Central, to South March,

## HOW TO BUILD RURAL TELEPHONE LINES

to Marchhurst, Harwood Plains, Huntley, Kinburn (in course of completion), Torbolton, Malwood, Dunrobin, Woodlawn, and Carp village, with twenty-three 'phones, making in all 54 miles of poles erected and 135 miles of wire.

"At the time of speaking Dr. Groves stated that the company had on hand to install twenty-five 'phones.

The Monk Telephone is a purely independent line. Every subscriber has to take one share of \$75 of stock and has six years to pay it up.

"The tolls amount to quite a considerable sum, as only subscribers are privileged to use it without paying a ten cent fee. The daily service is from 7 a.m. to 9 p.m., after which hour everyone, subscriber and outsider alike, has to pay a fee of ten cents for using the 'phone. Mr. E. J. Hughes is the central operator.

"The board of directors is: President, Robert Richardson; Vice-President, J. W. McElroy; Secretary-Treasurer and Managing-Director, Dr. G. H. Groves; other Directors, J. M. Argue, R. H. Richardson, R. Elliot, W. D. Monk, V. S. D., and Horace Downey.

"Carp Central is connected with Hazeldean, the Central of the Goulburn 'phone system and the two systems have arranged for free mutual communication over each other's territory."

### *WORKING "FINE."*

In its issue of October 29th, 1909, the same paper refers to another rural telephone company as follows:

THE NORTHERN ELECTRIC & MFG. CO., LTD.

"This week a representative of the *Ottawa Valley Journal* went into Goulburn Township to see how the rural 'phone system is working there. In a word and right at the beginning he was informed that it was working fine. For the information of readers and especially for those who are thinking of organizing a rural telephone in their section of the country, as well as to show what an enterprising community can do if they work together, the following account of the Hazeldean Rural Telephone System is furnished:

"The first thing the Goulburn people did, that is, two or three of them at first, and many of them in a short while, was to communicate with the secretary of another already established company to find out the way to do things and the cost of doing them. The advantages were, of course, too apparent to need enquiring into. In this case, the Goulburn promoters put themselves in communication with, the writer believes, the manager of the Leeds and Lansdowne Telephone Company. This was a co-operative system and the Goulburn men wanted a co-operative system. Having found out quite a number of necessary things they set to work to organize, and the Hazeldean Rural Telephone Company was formed, capitalized under the Ontario Companies Act. Dr. Shirreff was elected president of the company, Mr. J. J. Hodgins, vice-president, and Mr. R. H. Grant, secretary-treasurer, all of Goulburn Township. In June last they commenced work and on the first of September the lines were in operation. The farmers, some of them, it is said, were at first a little backward in coming into the

## HOW TO BUILD RURAL TELEPHONE LINES

company; but after it was on a fair way to completion the 'phones could not be put in fast enough to suit them. Now everybody is satisfied and the thing is a pronounced success.

"The system is on the co-operative plan, pure and simple, and independent. It is the shareholders' property, for every subscriber is a shareholder and just as much interested in the concern as the president or the secretary-treasurer. Each shareholder takes a \$75 share, payable in five yearly instalments of fifteen dollars. It is expected that this will pay for the building and operation of the lines for 5 years. After the 5 years are up there will be an adequate maintenance fee, commensurate with the requirements, charged for the maintenance and operation of the system. But for the first 5 years this \$15 a year from every shareholder pays for everything. The average number of subscribers to the mile to pay is three. You may erect the line with perfect confidence for three miles without a subscriber if at the end of the three miles you get nine subscribers. That is what is meant by securing three subscribers to the mile. In Richmond Village, which the company expects to reach soon, it has already fifteen subscribers and looks for more, and of course, these subscribers bunched together help to make up for the deficiency in other places along the line.

"The route of the Hazeldean Rural Telephone System is from Hazeldean, as Central, east out towards Britannia, beyond Bell's Corners and to Fallowfield, south and west to the boundaries of Goulburn Township and north-west to the margins of March and

THE NORTHERN ELECTRIC & MFG. CO., LTD.

Huntley Townships. With several spur lines, the whole line is 25 miles long. The company at present has 85 subscribers and expects to have between 200 and 300 when it has reached its best.

"The Hazeldean Rural Telephone System has free exchange with the Monk Rural Telephone System, its Central, Hazeldean, being connected with Carp Central. Between the two systems a subscriber has free communication with over 200 'phones at the present time. He has also connection with Ottawa, over a line from Hazeldean Central to the Bell Telephone Central at Ottawa, at a charge of ten cents. So that for ten cents he can communicate with any 'phone under the Bell Company in Ottawa. Thus the saving of journeys to the city, time and travelling expenses to many a farmer in the length of a year must be considerable. The company at present is extending as fast as possible its line south to Richmond. The poles are in line and active work going on. They are also picketing out some of the concessions in Goulburn for spur lines."

*A MUTUAL COMPANY.*

Again, in its issue of November 12th, 1909, the *Journal* writes:

"The Lanark and Ramsay telephone systems between Ferguson's Falls and Carleton Place, Lanark County, is the latest to attract attention, and it differs in some respects of organization from any other system yet described in these columns.

## HOW TO BUILD RURAL TELEPHONE LINES

"The Lanark and Ramsay Telephone Company is a joint stock company, but not yet incorporated or capitalized. It has sold no shares, and has had no shares to sell. It is thoroughly independent, with connections with the Bell system at Carleton Place.

"Briefly, fourteen farmers, upon a strictly and legally binding basis, have built and paid for the line equally man for man. These fourteen men assumed all responsibility and the line has now been in successful operation for three months. They wanted the 'phone in their houses and they have it. They are not ambitious about their new property, although they feel quite confident that the demand for it in the country around will call for its extension. From a purely business standpoint even, they feel sure that their money is well placed.

"The officials of the Lanark and Ramsay Rural Telephone Company are as follows: President, J. M. Quinn; Vice-President, A. Sheppard; Managing-Directors, W. J. Rathwell, Wesley Willis, H. McCreary; Secretary-Treasurer, A. Hammond.

"Mr. W. J. Rathwell first wrote a letter of inquiry to the supply company. This company instructed the farmers to arrange a meeting and that they would send a man down to give particulars, estimates, etc., of equipment. The meeting was held and fourteen present agreed to build, maintain and own the line. An experienced foreman was engaged to superintend the digging of the post holes, and the farmers turned in and helped in the work at reasonable wages. The farmers furnished the poles themselves and helped to

THE NORTHERN ELECTRIC & MFG. CO., LTD.

erect them. Some laborers were engaged, but all at reasonable figures. This having been done they engaged an expert, and he, along with two assistants, did the wiring and put in the 'phones. The whole line was further connected with the Bell Telephone at Carleton Place. In all, the Lanark and Ramsay Rural Telephone Company have seventeen miles of wire and some fifteen 'phones, including a short branch line running down to Innisville.

"It was the original intention to connect the line with Lanark and that will probably be done eventually, and in that way it would connect with the Lanark and Carleton Counties Rural Telephone System.

"Each 'phone has its own particular call. For outsiders a five cent rate is charged over local territory. It has a fifteen cent rate with the Bell Telephone at Carleton Place, whose main street, by the way, is a network of telephone, electric and telegraph wires. Of this fifteen cent rate, five cents goes to the Bell Telephone and ten cents goes to the Rural Company, and, of course, it has long distance connections. It expects, also, to put in many more 'phones all along the line."



## CHAPTER II.

*Company Organization—Mutual and Stock Companies—Constitution and By-Laws—Construction—Survey of Toll Lines.*

**T**ELEPHONE Companies are organized along two different lines, one is known as a Mutual and the other as a Stock Company. Following we give a few hints regarding both systems.

### *MUTUAL COMPANY.*

The majority of the companies organized for farm line work are run on a mutual basis. In organizing a rural line telephone system the first thing to be done is to call a meeting of the citizens of the vicinity to ascertain how many will subscribe for a telephone. The meeting should be called to order by a provisional chairman and purpose of same stated, and those who agree to take a telephone should signify their wishes by signing a list headed by something along the lines of the following:

"We, the undersigned, hereby agree to have a telephone installed in our residence (or place of business) and agree to pay therefor our proportion and share of cost of same, it being fully understood and agreed by and between the parties hereto, that the cost of same shall not exceed the actual cost of operating, and that each party hereto shall have equal expense in the purchase of material and building of lines."

THE NORTHERN ELECTRIC & MFG. CO., LTD.

Officers should be elected (President, Vice-President, Secretary and Treasurer) and a Purchasing Committee appointed, also a Committee to solicit subscribers in the neighborhood.

Expenses, etc., are usually taken charge of by the Secretary or Treasurer, and every six or twelve months a statement of expenses, "which are divided equally," is rendered to each of the members.

*STOCK COMPANIES.*

The most satisfactory way of organizing a telephone company is to make same a stock company. The company should be capitalized with an amount sufficient to provide for all its future needs and requirements. It should be incorporated under the laws of the Province in which it exists and care should be taken that all the proceedings of the meetings are recorded and legalized in every way possible. After incorporation, officers should be elected and stock issued to the several shareholders.

For an Exchange System in any large town it is necessary that franchise from the city government be obtained, and in small towns and villages where no franchises are granted permits should be secured from the local authorities. This is also true in the construction of party or toll lines running through the country.

*BASIS OF CONSTITUTION and BY-LAWS.*

*Constitution.*

We, the undersigned, stockholders of the telephone company to be hereinafter designated, in order to form

## HOW TO BUILD RURAL TELEPHONE LINES

a more perfect organization for the transaction of the business of the company and for the enforcement of such rules and regulations as the company shall deem necessary to protect the individual interests of each member, as well as the company at large, have adopted the following Constitution, By-Laws and Rules of Order:

Section 1. This company shall be known as the . . . . ., with central offices in . . . . ., and . . . . . to be managed and controlled by operators selected by the stockholders, subject to such rules and regulations as the company in any regular meeting shall adopt.

Section 2. The officers of the company shall consist of a President, Vice-President, Secretary and Treasurer, together with three Trustees, who shall constitute the board of management, and who shall be elected by a majority vote of the stockholders present at a regular meeting immediately after the adoption of this Constitution. The President, Vice-President, Secretary and Treasurer shall hold their offices for one year; and the Trustees, one for three years, one for two years and one for one year, to be decided by lot, to hold their offices until their successors are elected.

Section 3. The President shall preside at all meetings of the company, decide all questions that may arise while in session, subject always to an appeal to the house. He shall enforce the provisions of the Constitution and By-Laws, preserve order and decorum in the meeting and see that the rights of all the members are respected.

Section 4. The Vice-President shall preside in

THE NORTHERN ELECTRIC & MFG. CO., LTD.

the absence of the President and shall have all power and prerogatives of that officer while in the performance of his duty.

Section 5. The Secretary shall keep, in a book provided for the purpose, a correct record of the proceedings of each meeting, which shall be presented at the next meeting of the company for its approval. He shall keep a just and true account of all money that shall come into his hands and pay the same to the Treasurer, taking his receipt for the same. He shall have charge of all papers belonging to the company and deliver the same to his successor at the expiration of his office. He shall do all the corresponding for the company and attend to any other business that pertain to his office.

Section 6. The Treasurer shall keep, in a book provided for the purpose, a correct account of all the money that comes into his hands from all sources, keep a just and true account between the company and its members. He shall keep his books in such a manner that he can at any time report the financial condition of the company when called upon, and shall submit a full report to the company at the end of his term of office. He shall pay all orders on the treasury, signed by the President and Secretary, out of any funds not otherwise appropriated.

Section 7. The Trustees shall have charge of the telephone line, keep it in repair and shall have power to employ an expert whenever it is in such a condition that it can not be repaired by ordinary skill; may, if they deem necessary, divide the line into three divisions

## HOW TO BUILD RURAL TELEPHONE LINES

as equally as possible and each have charge of his own division. They shall have charge of all property of the company, and shall report to the Secretary from time to time as they may think necessary.

Section 8. The annual election of this company shall be held on . . . . . and each succeeding year on the same day and date, for the purpose of electing a President, Vice-President, Secretary and Treasurer, and one Trustee to serve for three years, as provided for in Section 2 of this Constitution. All officers of the company shall be required at this election to submit a report of their official acts for the information of the members, which report shall be adopted or rejected by a majority of the members present. Any other business pertaining to the company can be transacted at this meeting the same as at any other meeting of the company.

Section 9. The capital stock of this company shall not be increased except for repairs without a vote of the majority of the members. No member shall be allowed to own more than one share of stock, nor shall he be allowed to sell his share of stock until after he has offered it for sale to the company at a price not to exceed the original cost of the share. Any share of stock so purchased by the company shall be held as common stock of the company, but can be sold by the company to any person who is not a stockholder at the time of purchase.

Section 10. The property of this company shall not be transferred or sold to any other company without a three-fourths vote of the members at the time of

THE NORTHERN ELECTRIC & MFG. CO., LTD.

sale, and in case of said sale the proceeds shall be divided *pro rata* among the members.

Section 11. The President shall have power to call special meetings whenever it is deemed necessary and in case of his neglect or refusal to do so, a majority of the members shall have power to call such meeting. At all meetings of the company eight members shall constitute a quorum and each member shall be allowed one vote. The place of holding all meetings shall be determined by the members.

Section 12. The capital stock of the company shall consist of the poles, wires, insulators, brackets, cross-arms, guy poles or wire, money and books and other appurtenances belonging to the company, exclusive of the telephones and fixtures, which are the private property of the members and no part of the company stock.

Section 13. This Constitution may be changed or amended by a two-thirds vote of all the stockholders at any regular meeting.

*By-Laws.*

Article 1. Each member shall pay to the Treasurer the sum of . . . . . dollars, to be used for purchasing wire and materials for said line after poles are set. And in addition thereto, each member desiring a phone shall pay to the Treasurer the cost of said 'phone and necessary expenses of putting the 'phone in place.

Article 2. The price of each pole set shall be rated at . . . . . cents per pole, and the amount placed

## HOW TO BUILD RURAL TELEPHONE LINES

to the credit of each member in proportion to the number of poles furnished and set; and in the final adjustment of all accounts between the members, the member furnishing more than his proportion of poles shall be allowed a rebate on each pole furnished beyond the required amount, at the rate per pole above specified, and each member not furnishing his proportion of poles shall be assessed for each and every pole necessary to make his proportion equal to the other members. Provided that where poles of extra size and length are required in order to elevate the wires so as to escape the effects of electric light wires, or for any other purpose, the member furnishing such poles shall be credited with the actual cost necessary for the erection of such poles.

Article 3. After all the assessments made have been collected, and rebates and expenses paid, the surplus money on hand and not needed for the use of the company shall be refunded to the members in amounts that will equalize the expenses of each member, taking into consideration the cost of instruments furnished and the cost of putting them in proper position.

Article 4. No person shall be allowed the use of a telephone for more than five minutes at any one time. Any person or persons using the telephone who shall refuse to cease talking at the expiration of five minutes when requested to do so by any member wishing to use the line shall be fined the sum of ten cents for each and every offence.

Article 5. Common conversation shall not be permitted when the use of the line is required for the trans-

THE NORTHERN ELECTRIC & MFG. CO., LTD.

mission of business messages, and it shall be the duty of all members to see that the provisions of this Article are rigidly enforced.

Article 6. No member shall allow the use of his telephone free of charge to any person not a stockholder, except it be a member of his family, his partner in business, his employe or guest who is actually visiting his family, or a member of another line who has free exchange with this line, and then only to a stockholder. Any member who shall violate any of the provisions of this Article shall be charged with the full amount of the message so permitted.

Article 7. Any member of any other company having free exchange with this line who shall request to be switched on to this line for the purpose of sending a message for some other person not a member of this or some interchanging line, in his own name, shall be charged with the full amount of the message, and on his refusal to pay the same, he shall be denied the further use of the line.

Article 8. Any person (except those having free use of the line provided for in the foregoing Articles of these By-Laws) shall pay the sum of . . . . . cents for each and every message to any part of the line, and the additional amount of ten cents or more when the person to whom the message is sent has to be sent for.

Article 9. No person shall be added to the present number of stockholders without a two-thirds vote of all the members of the company.

Article 10. No abusive, profane, or obscene language shall be permitted to pass over the line. Any



## HOW TO BUILD RURAL TELEPHONE LINES

person so offending shall be fined the sum of \$1 and shall be deprived of the further use of the line until the fine is paid.

Article 11. No person shall be allowed to take down a receiver for the purpose of listening to a message passing over the line. Any person persisting in the violation of this rule shall be dealt with as the company shall deem most just.

### *Rules of Order.*

Article 1. At any regular or call meeting of the company, when the hour of commencement arrives, the President shall take the chair and call the house to order and proceed with the regular business of the meeting in the following order:

First: Reading the minutes of the last meeting, after which the President shall ask: "Are there any objections to the minutes as read by the Secretary? If not, they will stand approved." If no objections are made, he shall declare the minutes so approved.

Second: Reports of committees and action thereon.

Third: Petitions.

Fourth: Resolutions.

Fifth: Bills against the company.

Sixth: Bills in favor of some member of the company.

Seventh: General business.

Eighth: Unfinished business.

Ninth: New business.

Tenth: Adjournment.

THE NORTHERN ELECTRIC & MFG. CO., LTD.

Eleventh: All committees shall be appointed by the President unless otherwise directed by the company.

Twelfth: When a member wishes to speak on any subject before the house, he shall rise and respectfully address the President. When two members address the chair at the same time, the President shall decide which is entitled to the floor.

Thirteenth: No member shall be allowed to speak more than five minutes at one time, nor shall he be allowed to speak more than once on any question before the house until after the other members have had an opportunity to be heard.

Fourteenth: All questions before the house shall be decided by a majority vote of the members present, unless otherwise provided for in the Constitution and By-Laws.

Fifteenth: The rules of parliamentary practice comprised in Roberts' Rules of Order shall govern the deliberations of each meeting when not inconsistent with the foregoing rules of order adopted by the company.

### CONSTRUCTION.

#### *Preliminary Survey for an Exchange.*

After a company has been successfully organized and incorporated, ready to do business, it is then necessary to make a preliminary survey of the village or town in which the Exchange is to be located, in order that an accurate estimate of the cost of construction and installation of the necessary equipment may be made. This is best made by taking a large map of

## HOW TO BUILD RURAL TELEPHONE LINES

the village and marking the prospective subscribers thereon. These should be divided into two classes, those who in the judgment of the officers of the company are to be actual bona fide subscribers, about whom there is no doubt of their intentions of renting instruments, and those who are possible subscribers or who will probably subscribe at some later date. The first class will determine present needs of the company, while the latter will give some idea relative to the growth of the business. Such a map will enable the builders to lay out the pole lines, and aid their judgment in making up the estimates of the size and number of poles required, their equipment and cost of the wire. It is advisable and should be the aim of the company to place poles wherever possible in the alleys of the block rather than in the streets; this method, besides being a more economical form of construction, is more agreeable to the citizens of the town.

### *SURVEY OF TOLL LINES.*

When a toll or party line is to be built through the country, it is obvious that there is seldom a choice in routes, unless the future developments of the business enters as a considerable factor in the location. Their routes, once selected, are carefully gone over and notes taken with respect to the distances, contours, and conditions of the country. Poles are located on the side of the highway which is freest from trees. The roads should be crossed by the pole line as few times as possible, since every crossing requires additional expense in cross arms and guy wires. Poles are placed at

THE NORTHERN ELECTRIC & MFG. CO., LTD.

distances varying from thirty to forty poles per mile, according to the number of circuits and size of the wire they are to carry. The position of the poles is marked by stakes and carefully lined in by the aid of pike poles or other substitutes.

## CHAPTER III.

*Constructing the Line—Different Systems—Poles and Fittings—Setting the Poles—Guying—Line Wire and Stringing—Splicing—Insulation.*

**T**HERE are two systems of rural lines, namely; Grounded System (using one wire per circuit), and the Metallic System (using two wires per circuit).

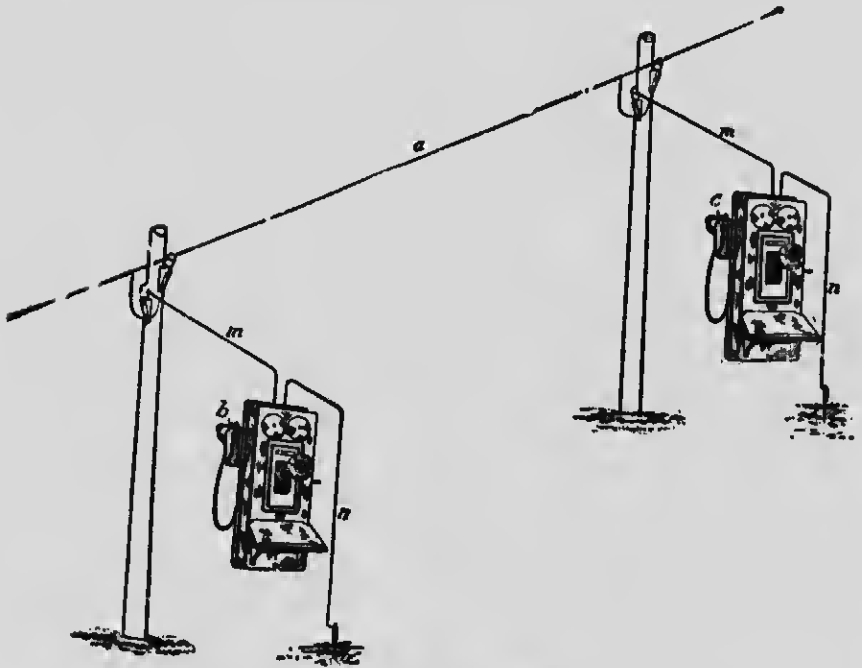

Fig. 1.—Diagram Showing Connections of the Grounded System.

**GROUNDED AND METALLIC SYSTEMS.**

Before arrangements are made for building the telephone line, a choice should be made between a grounded system and a metallic system. In the grounded system, Fig. 1, only one line wire, *a*, is necessary, and each of the telephones, *b*, *c*, etc., has one wire, *m*, connected to line and one wire, *n*, to ground. This system gives good results if properly installed and there are no electric light, power or trolley wires in the vicinity; otherwise, there is likely to be much objectionable humming and buzzing in the receivers.

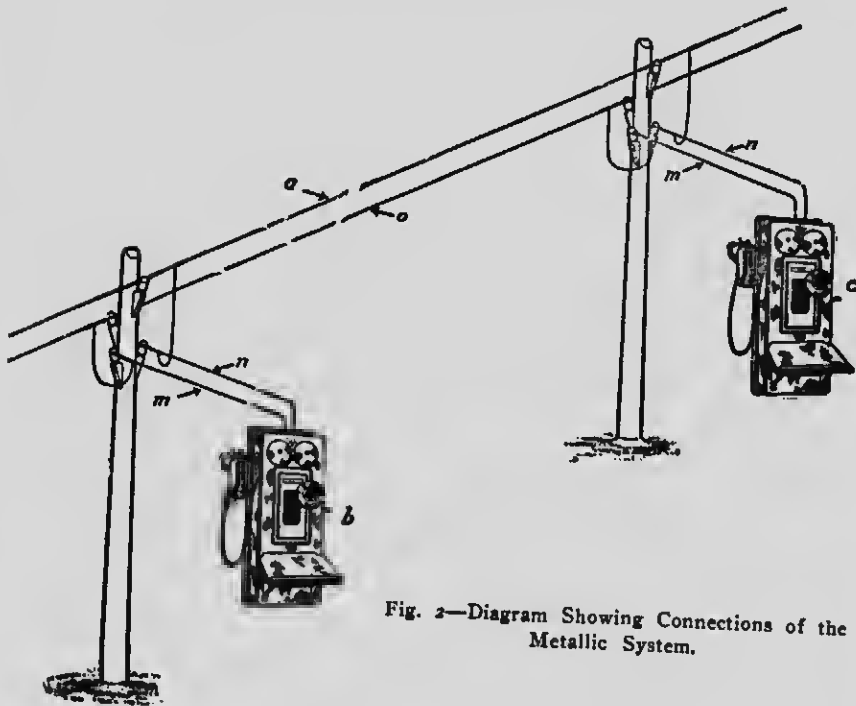

Fig. 2—Diagram Showing Connections of the Metallic System.

## HOW TO BUILD RURAL TELEPHONE LINES

In the metallic system, Fig. 2, there are two line wires, *a* and *o*, to which each of the telephones, *b*, *c*, etc., is connected by the wires *m* and *n*. This is the better system and should be adopted whenever the company can afford it. Whenever the line is built in the neighborhood of electric light, power or trolley wires, a metallic system has to be used in order to get quiet lines and clear talking, and the liability of damage by lightning is much less. Its only disadvantage

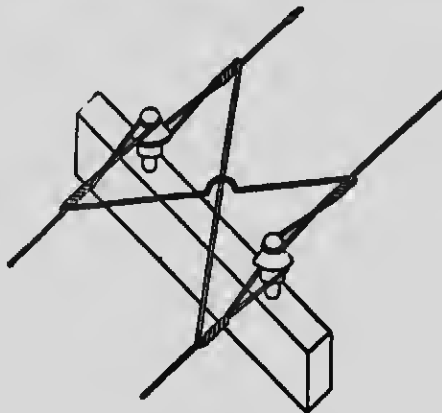

Fig. 3.

is the cost of the extra wire, brackets, etc. Where several metallic circuits are run on the same set of poles they should be transposed, that is, the wires of each circuit should be crossed and re-crossed as shown in Fig. 3, which is done to prevent "cross-talk" between the different circuits. Cross-talk may be explained as follows:

When two telephones are in use, subscribers on all the other lines on that set of poles can hear the con-

THE NORTHERN ELECTRIC & MFG. CO., LTD.

versation going on, although there may be no metallic connections, and if the lines run for a considerable distance on the same set of poles, this cross-talk would be so strong as to be objectionable. No definite rule is given here for this crossing and re-crossing, as different schemes are required for various numbers of lines on one pole route. There is no scheme of transposition for use on grounded lines that will prevent cross-talk.

*THE ROUTE OF THE LINE.*

The line should run past or near by the buildings in which the telephones are to be placed. It is not necessary to run the main line past each of these build-

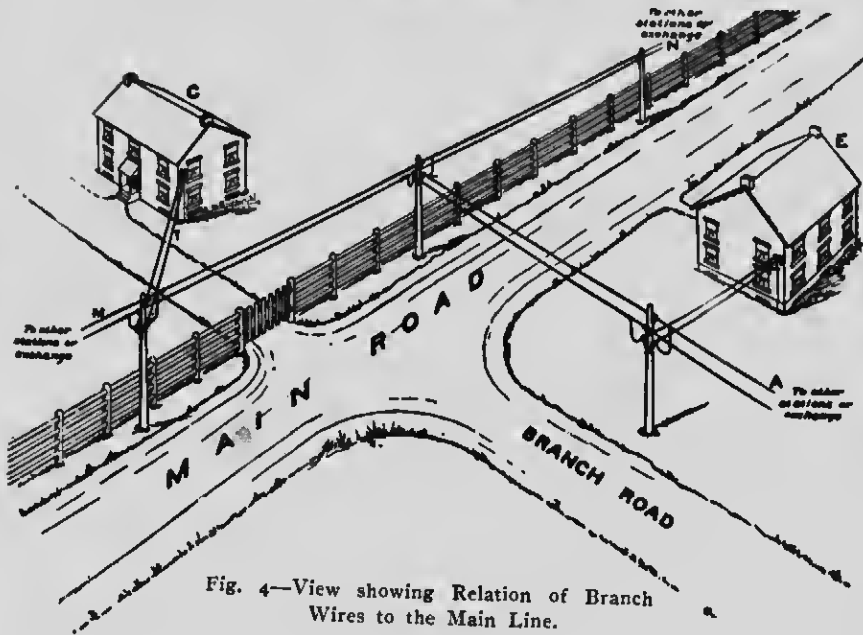

Fig. 4—View showing Relation of Branch Wires to the Main Line.



## HOW TO BUILD RURAL TELEPHONE LINES

ings, as branch wires can be run from the main line to the buildings and thus save wire and simplify the construction. Reference to Fig. 4, in which *c, c, etc.*, represent the buildings to be connected, *mn* the main line and *a* and *t* the branch wires, will make this point clear.

### POLES.

Poles twenty-two or twenty-five feet long of any good stock, cut when green, should be used. Cedar and chestnut are particularly desirable on account of their lasting qualities. The poles should be reasonably straight and well proportioned. The diameter

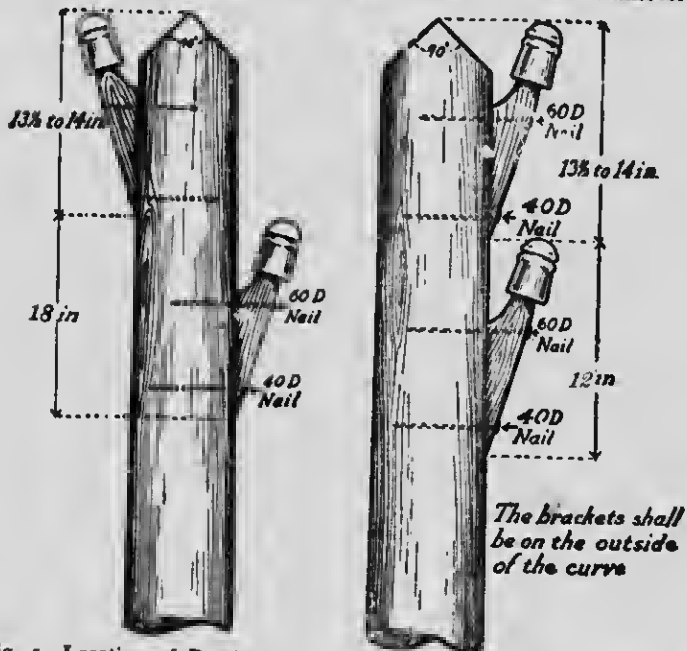

Fig. 5—Location of Brackets on Pole for Straight Lines.

Fig. 6—Location of Brackets on Pole at Curves.

THE NORTHERN ELECTRIC & MFG. CO., LTD.

of the top of the pole should be about 5 or 6 inches. In order to prolong the life of the poles and add to their attractiveness, all the bark should be removed, knots trimmed close and the butt cut off square. The top of the poles should be roofed as shown in Fig. 5.

*POLE FITTINGS.*

Where only one or two line wires are to be mounted on the poles, oak brackets fitted with glass insulators are fastened to the pole as indicated in Fig. 5 for straight lines, or as shown in Fig. 6 at curves. The brackets should be attached to the poles before the poles are raised.



Fig. 7



Fig. 8



Fig. 9

*BRACKETS.*

Brackets Figs. 7 and 8 are usually made of oak and given two coats of metallic paint and have a thread on the upper end to which is fastened a glass insulator, a type, as used in telephone work, is shown in Fig. 32.

They should be about 18 inches apart. The upper bracket should be 8 inches from the top of the pole

## HOW TO BUILD RURAL TELEPHONE LINES

and the other below it on the opposite side, Fig. 5. The bracket should be nailed to the pole with one 60-penny and one 40-penny nail.

### **CROSS-ARMS.**

Where three or more wires are to be run on the same pole, cross-arms should be used (Fig. 10).



Fig. 10.

They are made of sawed red pine, painted with two coats of metallic paint, and are of a length to accommodate from two to ten pins.

The size of the arm used for telephone work is  $4\frac{1}{4}$  x  $3\frac{1}{4}$  inches, bored for  $1\frac{1}{4}$  inch pins. Standard pin is shown in Fig. 9.

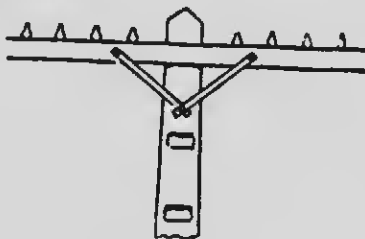

Fig. 11.

The proper way to attach the cross-arm to the pole is to cut a gain (Fig. 11) about  $1\frac{1}{2}$  inches deep, 10 inches from the top, and of such width as to cause a tight fit of the arm. Each cross-arm shall then be attached to the pole by one cross-arm bolt (Fig. 12) which shall be long enough to go through the pole and cross-arm without cutting out the back of the pole.

THE NORTHERN ELECTRIC & MFG. CO., LTD.

The bolt shall be driven through from the back of the pole, a square washer (Fig. 13) being placed under the head. A square washer (Fig. 13) shall also be placed under the nut. The placing of the bolt in this way aids in making crossarm replacements or changes.

Two lag screws (Fig. 14) can be used for this purpose, but they are not quite as good. The arm may be further braced by the use of two iron braces commonly termed cross-arm braces (Fig. 15). These



Fig. 12.



Fig. 14.



Fig. 13

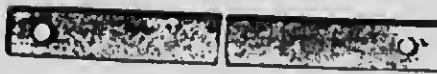

Fig. 15.

usually consist of straight flat galvanized iron bars 1 inch wide by  $\frac{1}{4}$  inch thick, varying in length from 20 to 28 inches. Holes are usually punched in one end for the reception of 5 x  $\frac{1}{2}$  inch lag screws, and in the other end for 4 x  $\frac{3}{8}$  inch carriage bolts.

#### FACING CROSS-ARMS.

On straight lines, where the distances between the poles are equal, the cross-arm should be placed on alternating sides of the pole. On curves, the cross-arms should be placed on the poles so that the strain of the wire will pull the cross-arm against the pole. Then the strain of the wire is on the pole instead of the bolts. On straight lines the wire should be tied to the insulator in the position as shown in Fig. 16. On curves

## HOW TO BUILD RURAL TELEPHONE LINES

and corners the wire should be tied to the side of the insulators away from the strain, as shown in Fig. 17.

The quickest way to erect a line is to do all the work on the poles, such as attaching brackets or cross-arms, before the poles are set into the holes.



Fig. 16.

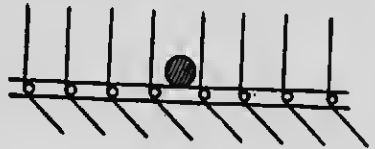

Fig. 17.

### *LIGHTNING RODS.*

Every tenth pole should be equipped with a lightning rod, made of No. 9 or No. 10 wire, stapled on the side of the pole and attached every two feet by  $\frac{1}{2}$ -inch galvanized iron staples. The rod should be extended to the top of the pole and have two hand turns under the bottom end of the pole.

### *SETTING OF POLES.*

Poles from twenty-two to twenty-five feet in length should be set at least four and one half feet in the ground, and on curves, six inches or a foot deeper. The post holes should be large enough to admit the poles without stabbing or hewing, to permit the free use of the tamping and digging bar and should be full size at the bottom. The position of the poles is marked by stakes and carefully lined in by the aid of pike poles or other substitutes.

After the pole is placed in position, the earth must be well tamped as the hole is filled. Soil should then

be piled up above the surface, as in Fig. 18, and firmly packed about the pole to the height of at least twelve inches above the ground. In filling the holes, the coarse soil or gravel should be used at the top of the hole.

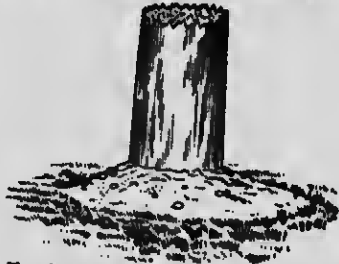

Fig. 18—Earth Should be Slightly Banked Around the Pole as Here Shown.

### GUYING.

Every corner pole and every pole not in line should be guyed before the wire is stretched, or else the line will not stand up properly and will always be giving



Fig. 19.

## HOW TO BUILD RURAL TELEPHONE LINES

more or less trouble. This can be done by a brace or by running a No. 6 or No. 9 wire from the top of the pole to an anchor which should be set in the ground four feet (Fig. 19), or by running a guy wire from the top of the pole to a suitable guy stub, as shown in Fig. 20. Single guys to anchor should be used whenever possible and set in the line of the resultant

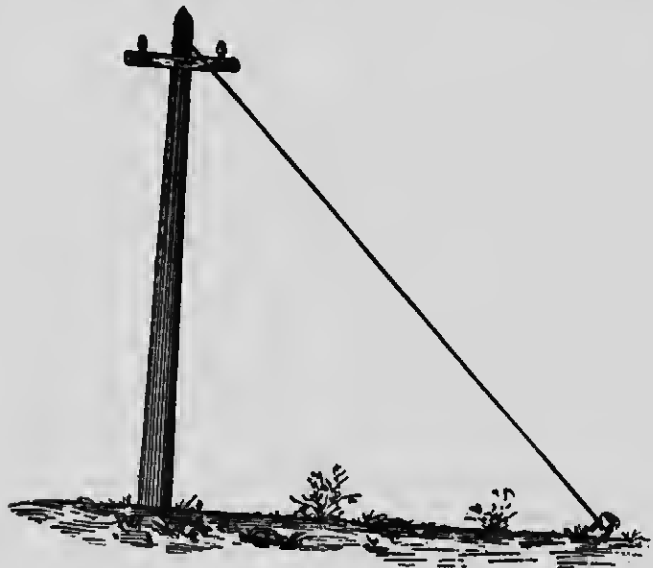

Fig. 20.

strain from the line wires, as shown in Fig. 21. Where it becomes necessary to raise the guy strand to a sufficient height to clear obstacles, cross the highway, guy stubs should be used as in Fig. 22. Road crossings may be guyed as shown in Figs. 23 and 24. Corners may be guyed as shown in Figs. 25 and 26.

THE NORTHERN ELECTRIC & MFG. CO., LTD.

Do not guy to fences or trees, as they are not permanent and the swaying of the trees will break the wire.

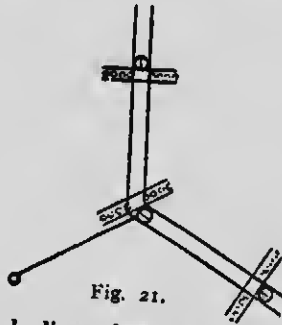

Fig. 21.

On heavy pole lines, head guys are sometimes used to stiffen the line (Fig. 27). In hilly country head guys are sometimes used as in Fig. 29.

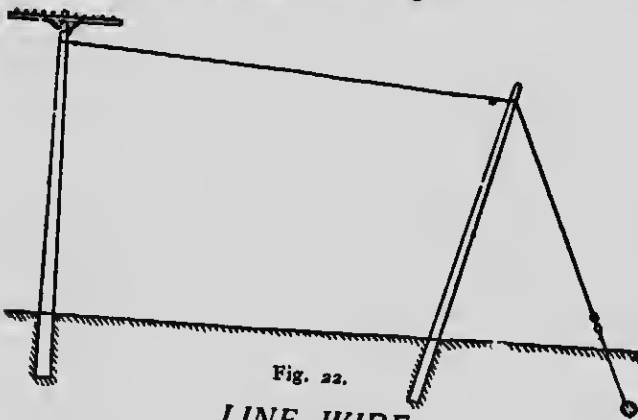

Fig. 22.

**LINE WIRE.**

No. 12 E.B.B. double galvanized iron telephone wire should as a rule be used for rural lines, although a smaller size wire (No. 14 E.B.B.) may be used on lines up to twelve miles in length. However, the No.



## HOW TO BUILD RURAL TELEPHONE LINES

12 gauge wire is recommended, especially if it is likely that the line will be lengthened at any time in the future.

Although commercial fence wire costs less at the outset than the standard E.B.B. grade telephone wire, we strongly advise against its use as a substitute for double galvanized telephone wire. Examine a piece of fence wire at your first opportunity. Take some

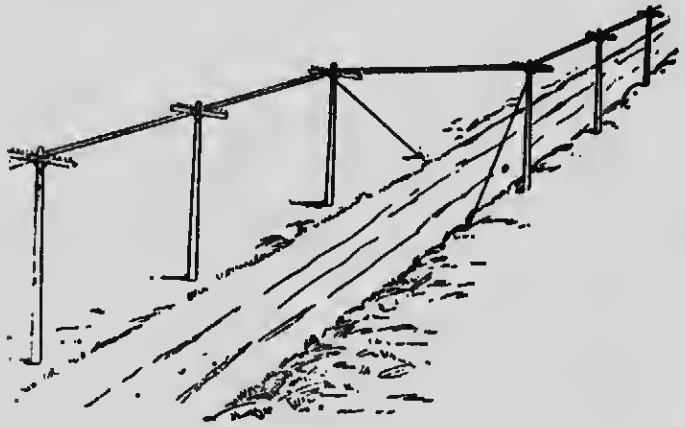

Fig. 23.

which has been in use only a few months, bend it, see the galvanizing chip off and note the all-consuming rust which has accumulated. At the same time inspect, if possible, a piece of Double Galvanized Iron Telephone Wire which has been in use for years, subjected to all the elements and note the absence of rust on it. After such a test you will readily realize the superiority of wire of the right sort. Ordinarily, the life of fence wire is only about one-third that of Double Galvanized

THE NORTHERN ELECTRIC & MFG. CO., LTD.

Iron Telephone Wire, it also has a higher resistance which interferes with the ringing and talking on the line.

This does not mean that fence wire is unfit to use for fencing. The single coat of galvanizing given it will protect it from rust for a while and when this coat is gone, so long as the wire remains attached to the posts, it still makes a fence—it is still fence wire.



Fig. 24.

But what if it is placed in service as telephone wire. When the galvanizing is gone, when rust has eaten into the wire so that it will no longer conduct the required current, it may remain attached to the poles, but it is not telephone wire. If the telephone wire fails to give service as such, it must be replaced.

A wire clamp, is used for stretching the line wire tight. It consists of a clamp which has an automatic

HOW TO BUILD RURAL TELEPHONE LINES

arrangement whereby the wire is automatically gripped when a strain is exerted on the pulley blocks to which

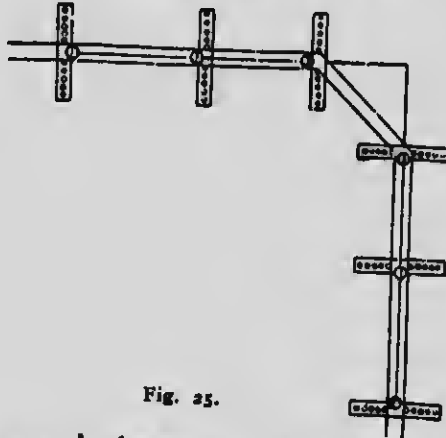

Fig. 25.

the clamp may be fastened. The clamp releases automatically as soon as the strain on it is released.

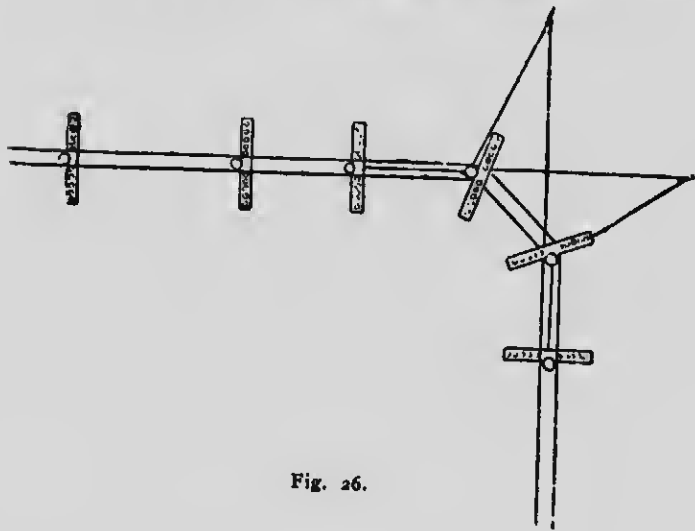

Fig. 26.

**INSULATORS.**

A regular pony glass insulator, such as is used for supporting telephone wires on brackets or cross-arms, is shown in Fig. 32.



Fig. 28—Method of Attaching Pole Climbers to the Legs.

**STRINGING THE WIRE.**

The line wire should be carefully unwound along the line of poles so it will be free from twists and kinks.

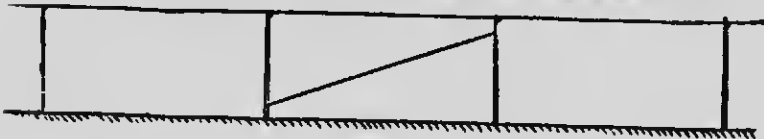

Fig. 27

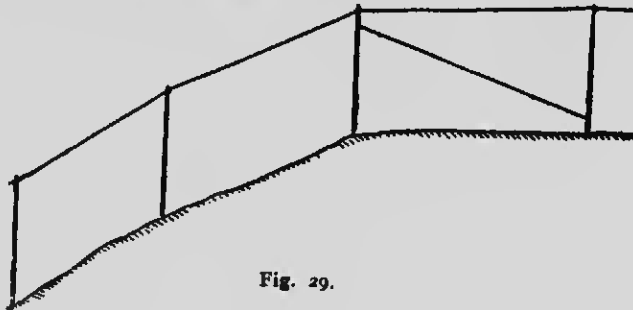

Fig. 29.

## HOW TO BUILD RURAL TELEPHONE LINES

and then drawn to the top of each pole and tied to the insulators as described later on.

An iron climber, Fig. 28, strapped to each leg of the man putting up the wires will aid him in mounting the poles. The wire should be given a sag of about 12 inches between poles spaced 176 feet apart and a proportionately smaller sag if the spacing is less.

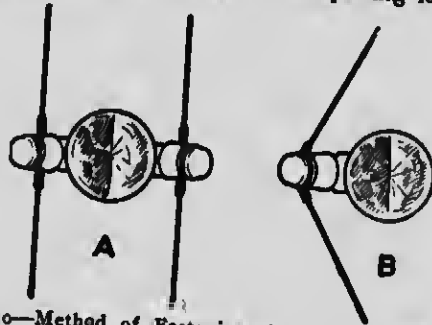

Fig. 30—Method of Fastening the Line Wires to the Insulators—A on Straight Lines; B at Curves.

### *METHOD OF TYING AND SPLICING.*

On straight lines the wires should be fastened to the insulators as shown at *A*, Fig. 30, and at curves it should be fastened as shown at *B*. Both of these views show the construction as one would see it from the top of the pole. The line wire should be tied inside of the insulators on straight lines and outside at curves.

Details of the method of tying, splicing, and dead-ending iron line wire are shown in Fig. 31. They are tied to the insulators as shown at *A*; spliced together as shown at *B*; and dead-ended or terminated at an insulator as indicated at *C*.

THE NORTHERN ELECTRIC & MFG. CO., LTD.

In tying an iron line wire to an insulator, the tie wires should be of the same size and material as the line wires and should be about twenty inches long.

Both ends of the wire should pass under the line wire and make two and a half complete turns. All joints or splices should be soldered.

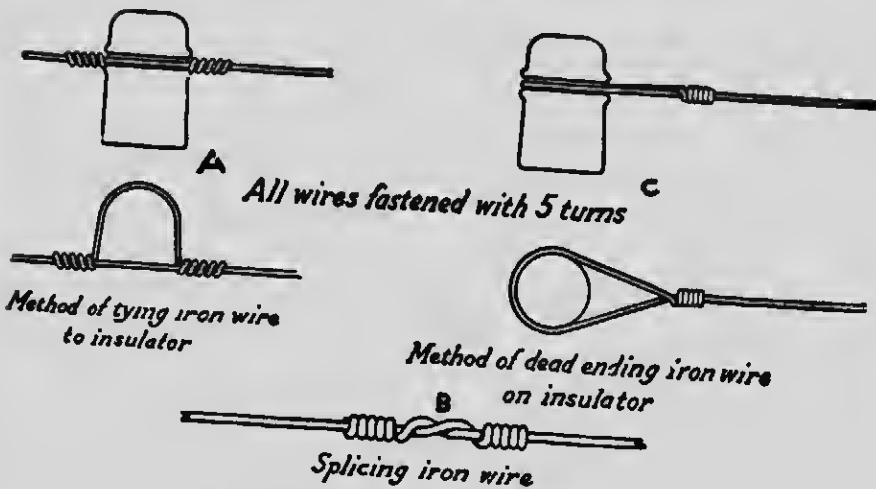

Method of tying iron wire to insulator

Method of dead ending iron wire on insulator

Splicing iron wire

*All joints should be soldered*

Fig. 31—Details of Tying, Splicing and Dead Ending Iron Line Wire.

If copper line wires are used, a line should be tied to the insulators as shown in Figs. 33 and 34. One end of the tie wire should pass over the line wire and be given five complete turns. The other end should pass under the line wire and be given five complete turns.

## HOW TO BUILD RURAL TELEPHONE LINES

### SPLICING WIRE.

The illustrations (Figs 32 and 33) show the wire in the position of the tie, and the tie after completion.

Where copper wire is used special connectors should be employed, called McIntyre sleeves, which consist

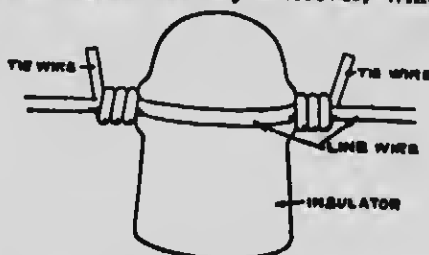

Fig. 32.

of a double sleeve (Fig. 35) with two tubular openings. The wires to be connected are inserted in opposite directions, one wire into each opening in the joint. The whole is then twisted, making a perfect

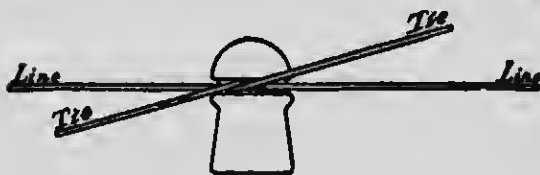

Fig. 33.



Fig. 34.



Fig. 35.



Fig. 37.

THE NORTHERN ELECTRIC & MFG. CO., LTD.

and non-corrosive joint (Fig. 36). The tensile strength of the joint is greater than the wires themselves. No heat or solder is required in making the connections, and the joint once in place will never pull out. The joints do not create any resistance on the line, as the connection made is perfect and equal to soldering. The sleeves for copper wire are made of copper and are furnished in the standard size, Brown & Sharp gauge. For galvanized iron telephone wire,



Fig. 36.

similar connectors, heavily tinned inside and out, are used. They are furnished in British gauge of a standard size. Whenever a connection is made, the wires should be made as bright as possible, so as to afford good contacts with the inner walls of the connector. In Figs. 35 and 36 are shown the connectors before and after twisting. Galvanized iron telephone wire is usually spliced, as shown at *B* in Fig. 31. The method shown in Figs. 35 and 36 is, however, much better. In splicing wire, a tool called a splicing clamp (Fig. 37) is necessary to do satisfactory work.

### INSULATION.

The insulation of the telephone line means its isolation from anything that would tend to conduct the electricity direct to earth instead of passing through the telephones in such proportionate quantities as it



## HOW TO BUILD RURAL TELEPHONE LINES

should. The insulation of the telephone line should, of course, be as good as it is possible to make it. Telephone lines must not be allowed to touch or come in contact with tree tops, for the limbs and leaves would tend to ground the lines, and the swaying of the trees might, in some cases, break the wire. Where telephone lines run through wooded sections, it is well to trim off the tops of all the trees.

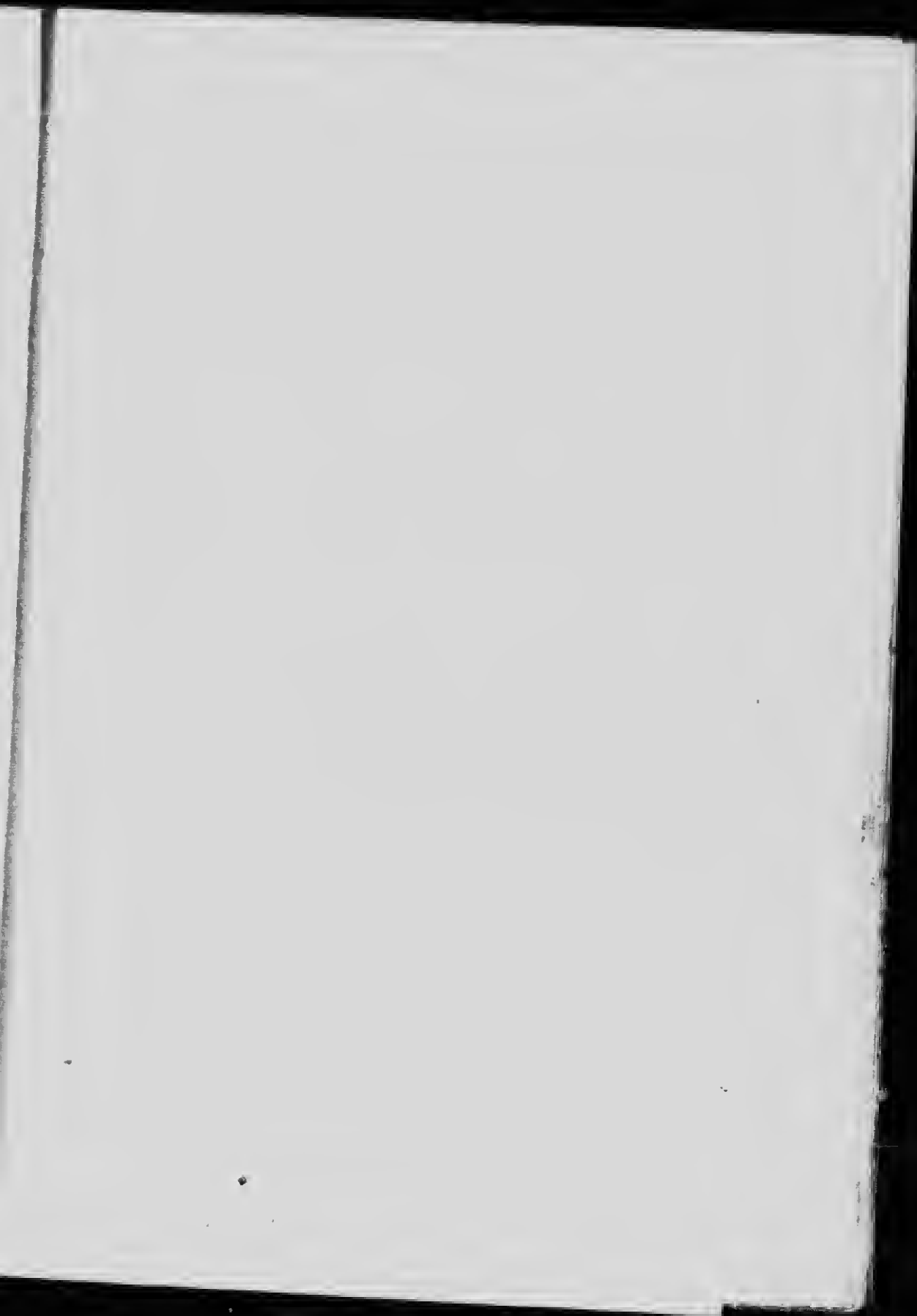



Fig. 38  
Lightning Protector for Use Where There are No  
Power or Lighting Wires.

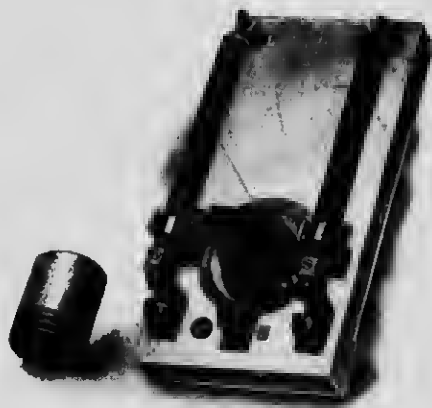

Fig. 39  
Telephone Protector which Guards against Lightning  
and Power Currents as well as from Lightning.

## CHAPTER IV.

*Installing the Instruments—Connecting to the Line—  
Protectors—Drop Wires—Inside Wiring—  
Ground Wires—Batteries—How to Use  
the Telephone—Signals.*

A WALL telephone set should be securely fastened to the wall by means of wood screws. To fasten the set to a brick, cement or stone wall, holes should first be drilled into the wall at the proper position for the screws. The holes should then be plugged with wooden plugs and the wall set fastened to them with wood screws. Care should be taken that thoroughly dry wood is used and that the plugs are large enough to hold securely.

### *INSTALLING THE PROTECTORS.*

The protectors should be mounted upon the wall where the line wires enter the building. All the inside wiring and the building itself are thus protected. The protector should not be exposed to water or dampness, but should be conveniently placed for inspection. In localities where there are no electric light or power wires, the lightning protector shown in Fig. 38 should be used. If there is danger of the line becoming crossed with lighting or power circuits, as well as danger from lightning, the protector in Fig. 39 is recommended.

## HOW TO BUILD RURAL TELEPHONE LINES

### CONNECTING THE TELEPHONE INSTRUMENTS TO THE LINE.

#### *DROP WIRES.*

Bare wire, similar to that used on the main line, can be run between the house and the nearest line pole. No. 16 Style B. twisted pair copper wire is generally used where the distance is less than 150 feet.

When a branch line is connected to the main line or when connection is made between the main line and

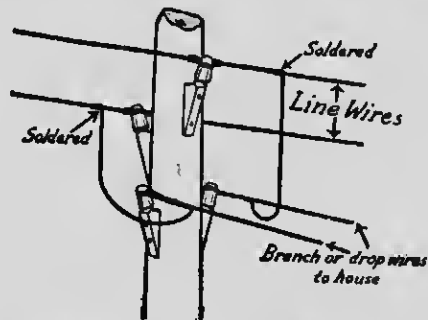

Fig. 40—Method of Attaching Branch or Drop Wires to the Pole.

a house by means of a drop line, the branch or drop wires should be dead-ended on separate insulators and their ends left long enough to be connected to the line wires. The method of attaching these drop wires to the pole is shown in Fig. 40, and the method of attaching them to the house is shown in Fig. 41. If the wires run along the outside of the building they should be carried on insulators, as shown in Fig. 42, to the point where they enter the house.

### ENTRANCE HOLES.

Two separate holes, at least  $2\frac{1}{2}$  inches apart and sloping upward from without, should be made in the building near to the point where the protector is mounted.

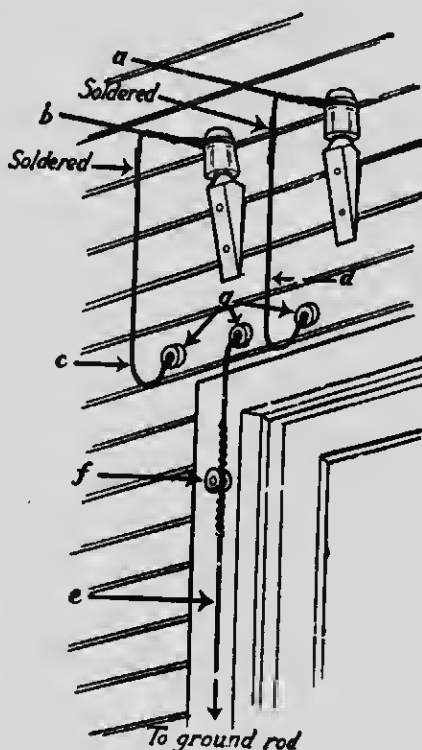

Fig. 41—The Drop Wires are Fastened to the House as Here Shown.

### LEADING-IN WIRES.

The leading-in wires which connect the drop wires with the terminals of the protector should be braided,

## HOW TO BUILD RURAL TELEPHONE LINES

rubber-covered copper wire. They must be soldered to the end of the drop wires, as shown in Fig. 41, where *a* and *b* represent the drop wires and *c* and *d* the leading-in wires.

A drip loop should be left in each leading-in wire at a point immediately below the entrance hole in the building. This is to prevent water following the wire through the hole and into the building.

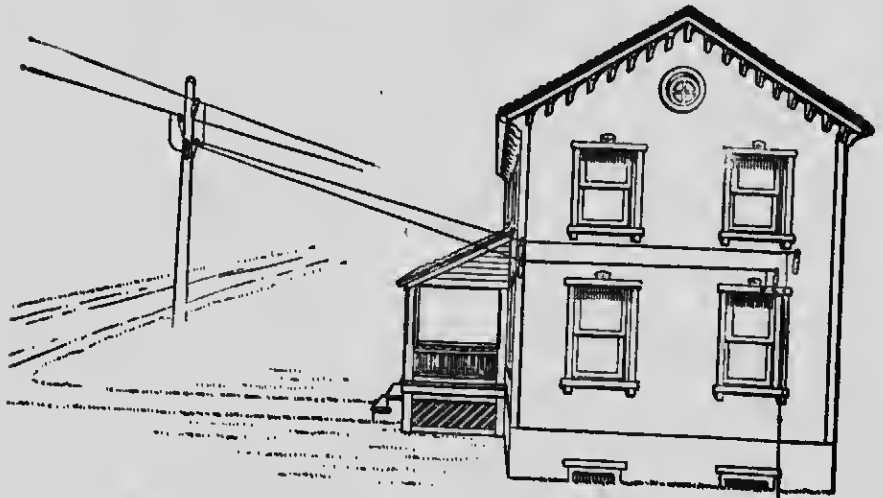

Fig. 42—View Showing How the Drop Wires, When Run Along the Outside of a House, Are Supported on Insulators.

At the point where the leading-in wires pass through the holes in the building they should be protected by porcelain tubes, as shown at *g*, Fig. 41, and in Fig. 43. The leading-in wires should not be left in contact with any sharp corners or edges on the outside of the building.

*INSIDE WIRING.*

No. 20 B. and S. gauge braided and rubber-covered twisted pair copper wire should be used for connecting the telephone set with the protector. The methods of wiring the telephone set and protector on a grounded system and on a metallic system are shown respectively at *A* and *B* in Fig. 43.

All inside wires should be installed in a neat man-

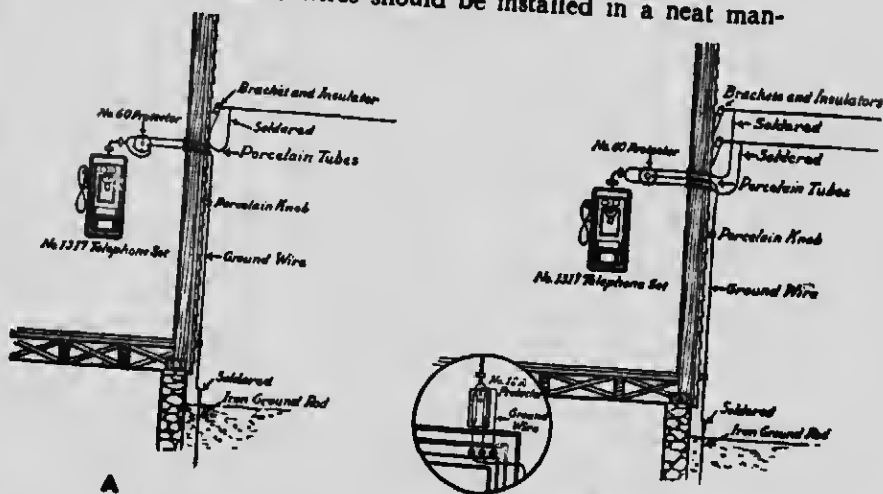

**A** Fig. 43—Methods of Wiring a Telephone Set and Protector:  
A on a Grounded System; B on a Metallic System.

ner. As far as possible they should be concealed. When it is impossible to conceal the wires they should be run along the door or window casing against the plaster, under the picture moulding, or in the groove at the top of the base-board. When it is necessary to install these wires in cellars or attics, care should be taken to avoid the possibility of damage from mechani-



## HOW TO BUILD RURAL TELEPHONE LINES

cal sources. Wet and damp localities should be avoided for all inside wiring.

When it is necessary to cross pipes or other conducting materials, the wires should be protected by tubing or two wrappings of insulating tape. The tubing or tape should project at least one inch each side of the pipe or conducting material. Whenever practicable, the wires should be run above all pipes or conducting material that it is necessary for them to cross.

When necessary, wires within the building may be spliced and soldered. In splicing wires, resin (not acid) should be used as a flux for the solder. Joints must be soldered and carefully wrapped with insulating tape.

Wire should be fastened so as not to injure its insulation. For inside work, fibre cleats or insulated staples driven between the wires may be used. Uninsulated staples should never be employed.

Be careful to screw tight the binding posts on the telephone and on the batteries, so that they will make good connections.

### *GROUND WIRE.*

Single braided, rubber-covered copper wire should be used for connecting the protector with the ground rod. This ground wire (not smaller than No. 19 B. and S.) from the protector should be led as direct and with as few bends as possible to the ground connection. A porcelain tube, *g*, Fig. 41, should be used where the ground wire, *e*, passes through the wall, and porcelain knobs, *f*, to prevent it coming in contact with the house. There should be no spirals, coils, knots or



Fig. 44

Method of Connecting Three Cells of Dry Battery

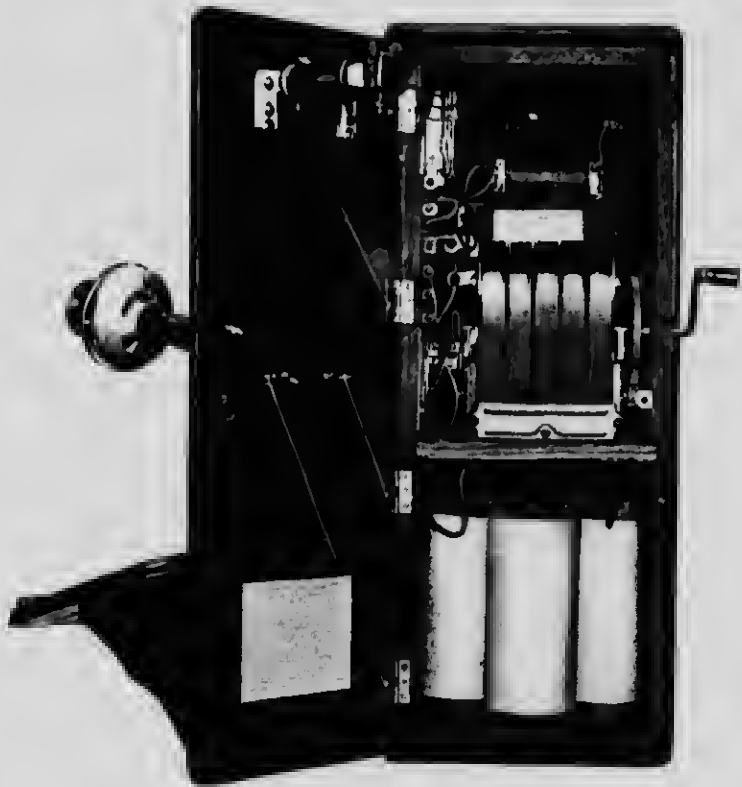

Fig. 45

No. 1317 Type Telephone Set, Open

THE NORTHERN ELECTRIC & MFG. CO., LTD.

sharp bends in the ground wire and it should never be enclosed in an iron pipe.

A good ground connection for the protector, and one which will also serve well as the ground connection of the telephone in a grounded system, can be obtained by soldering the ground wire to the top of an iron rod five or six feet long and one-half inch in diameter, driven into permanently damp earth. Iron rods for this purpose can be purchased from us. Do not try to use a piece of iron wire for ground, as it will not prove satisfactory. Another good method of making a ground is to solder a copper wire to a copper plate, dig a hole about six feet deep in some damp place, place the plate in the bottom, cover with charcoal, empty in a few pails of water and cover with earth. Too much attention cannot be given to this matter of making a ground, which, if slighted, will cause the strongest and best telephone made to give no better results than a much weaker telephone on a system having a good ground.

*BATTERIES.*

Three cells of dry battery should be connected together as shown in Fig. 44, and placed in the lower part of the telephone set. The wires, *m* and *n*, in the telephone set must then be connected with the battery as shown in Fig. 45.

HOW TO USE A TELEPHONE.

*HOW TO RING UP.*

First turn the generator crank briskly with the right hand. This sends a current through the line which

## HOW TO BUILD RURAL TELEPHONE LINES

rings the bell of the party wanted. After "ringing up," remove the receiver from the hook and apply it to the ear. The hook, relieved of the weight of the receiver, immediately springs up. As soon as the party responds, you begin the conversation by speaking into the transmitter and hearing from the distant party through the receiver.

### *HOW TO RING OFF.*

On completing your conversation, hang the receiver on the hook, with the ear piece pointing down, which is pulled down by its weight, and having done this ring off by a few rapid turns of the crank, ringing the bells and thus informing the other parties on the line that you are through with the line.

### *CODE OF SIGNALS.*

Where a number of instruments are used on the same line, as in the case of party lines, it sometimes becomes quite a difficult problem to have sufficient signals for the different instruments, which can be distinguished one from the other. Below is illustrated a code of signals up to 22 instruments. No. 1 call is made by giving one long ring; No. 2, by one long and one short ring; No. 3, by two short rings and one long ring, and so on.

1	Central	—
2		— —
3		— — —
4		— — —

THE NORTHERN ELECTRIC & MFG. CO., LTD.

5	_____
6	_____
7	_____
8	_____
9	_____
10	_____
11	_____
12	_____
13	_____
14	_____
15	_____
16	_____
17	_____
18	_____
19	_____
20	_____
21	_____
22 Gen. Ring	_____

## CHAPTER V.

### *Materials Required—For Main Lines—For Each Telephone Station.*

**T**O afford an idea of what is required to build a telephone line, we have listed below the material needed for each mile of line.

#### *MATERIAL REQUIRED FOR THE MAIN LINE.*

Case I. When the line is not to be more than twelve miles long. If a "grounded" one-wire line is put up there will be required for each mile:

96 pounds of No. 14 E.B.B. galvanized iron telephone wire.

30 No. 9 pony glass insulators.

30 12-inch painted oak brackets.

30 40-D and 30 60-D wire nails.

30 22 or 25-foot poles.

Case II. When a "metallic" two-wire line not more than twelve miles long is to be built there will be required for each mile:

192 pounds of No. 14 E.B.B. galvanized iron telephone wire.

60 No. 9 pony glass insulators.

60 12-inch painted oak brackets.

60 40-D and 60 60-D wire nails.

30 22 or 25-foot poles.

THE NORTHERN ELECTRIC & MFG. CO., LTD.

Case III. When the line is to be more than twelve miles long. If a "grounded" one-wire line is to be put up there will be required for each mile:

165 pounds of No. 12 E.B.B. galvanized iron telephone wire.

30 No. 9 pony glass insulators.

30 12-inch painted oak brackets.

30 40-D and 30 60-D wire nails.

30 22 or 25-foot poles.

Case IV. When a "metallic" two-wire line more than twelve miles long is to be built there will be required for each mile:

330 pounds of No. 12 E.B.B. galvanized iron telephone wire.

60 No. 9 pony glass insulators.

60 12-inch painted oak brackets.

60 40-D and 60 60-D wire nails.

30 22 or 25-foot poles.

**MATERIAL REQUIRED FOR EACH  
TELEPHONE STATION.**

At each telephone station on either kind of line, there will be required:

1 No. 1317 telephone set, which includes:

1 No. 144 receiver.

1 No. 250 transmitter.

1 No. 92 receiver cord.

4 1¼-inch screws (to fasten transmitter to telephone).



## HOW TO BUILD RURAL TELEPHONE LINES

- 3 Dry batteries.
- 20 ft. No. 20 style "C" wire (to run from protector to telephone).
- 75 feet No. 16 style "B" wire (to run from line to protector).
- 15 feet No. 16 ground wire (to run from protector to ground).
- 1 6-foot iron ground rod.
- 4 No. 4½ porcelain knobs.
- 4 3-inch No. 16 flat head wood screws (to fasten knobs to house).
- 2 4 x ¾ porcelain tubes (to carry wire into house).
- 20 2-wire wood cleats and screws.

When you are ready to order material for a new telephone system or for extensions to an existing one, simply specify Case 1, Case 2, Case 3 or Case 4 (see pages 66 and 67) and we will supply the material promptly. We will be glad to furnish estimates and prices upon application.





Fig. 46  
No. 1317 Type Telephone Set

## CHAPTER VI.

*The 1317 Type Telephone Set—New Features—  
Woodwork and Assembly—Transmitter—Re-  
ceiver—Ringers and Gongs—Generator—  
Switch Hook—General—Specifications.*

**U**P to this point we believe we have shown clearly the proper procedure in the formation and construction of a Rural Telephone System. We have pointed out that it is always in the interest of those contemplating telephone construction to use the very best material obtainable. This is particularly true in the selection of the telephone sets for the line, in which the greatest amount of care should be exercised, so that the sets will meet the most exacting requirements at all times.

We recommend our newly designed No. 1317 Type Telephone Set (Fig. 46) as specially adapted for long rural party lines. This set was designed by the most expert telephone engineers on this continent and \$10,000 was spent in its development before a single set was put on the market. It is the most perfect set ever offered by any manufacturer to the public.

We would specially like to call your attention to the low cost of maintenance and high efficiency in operation of this set.

### *NEW FEATURES.*

#### *Binding Posts.*

All of the binding posts are provided with screw connections and are placed inside of the case, side by

## HOW TO BUILD RURAL TELEPHONE LINES

side, where they can be most easily reached. The placing of the connectors inside the set prevents trouble from tampering with connections and accidentally short circuiting the set at the line terminals.

### *Condenser.*

Terminals are provided so that a condenser may be connected in the receiver circuit at any time if desired. This is known as the No. N1-A Condenser.

### *Push Button.*

Where push button system of signaling Central without ringing the other subscribers on the line is used, we have designed a key which is conveniently located at the left hand side of the case. This is known as the No. N1-A Key.

### *Accessibility.*

The door is hinged at the left. This permits one to examine more easily the operation of the apparatus; as the generator crank can be turned equally well with the door open or closed.

The following are some of the reasons why the No. 1317 type telephone set is the most efficient set for rural line work on the market to-day, proving it to be the acme in telephone construction.

### *WOODWORK AND ASSEMBLY.*

1. The apparatus is not crowded, all parts are readily accessible (a cramped space means slow work).
2. The doors open to the left, unlike any other set. This makes it possible to watch the operation of the ringer while turning the generator, besides avoids

THE NORTHERN ELECTRIC & MFG. CO., LTD.

the chance of tearing the hinge from the door of the set, if in throwing it open it chances to hit against the generator crank.

3. The backboard is slotted the entire length in order to permit the wires to enter either from above or from below without being run around the set.

*TRANSMITTER.*

4. The transmitters are the standard "Northern Electric" type. One of the so-called standard transmitters sold to-day requires nearly 700 per cent. more current than ours—your dry cells will last longer with Northern Electric transmitters.

*RECEIVER.*

5. Like the transmitter, we supply with this set our standard "Northern Electric" receiver, over 250,000 of which are in use in Canada to-day.

6. Each part of the receiver is the result of long and careful study which has resulted in the best possible combination.

7. The concealed binding post receivers are built with an enclosed metal cup and each has a felt washer that prevents dust from accumulating on the back of the diaphragm, likewise keeps out all local noises that so frequently spoil transmission.

*RINGER AND CONGS.*

8. Our new No. 38 type ringer is very sensitive and efficient. Every ringer on the market requires

## HOW TO BUILD RURAL TELEPHONE LINES

more current to operate it than this one—some require three or four times as much.

9. The armature can be quickly and easily adjusted by moving just one screw with an ordinary screw driver—no pliers or wrenches required.

10. The gongs may be accurately adjusted by means of the cam screw—a screw driver is the only tool necessary for all adjustments.

11. The gong posts are mounted directly on the ringer frame so that even the warping of the woodwork cannot change the adjustment.

12. The unusually large brass gongs produce a great volume of sound, nearly 50 per cent. louder than the gongs on other sets.

### *GENERATOR.*

13. The No. 48 type generator which is used in the No. 1317 type telephone set is a five bar, open circuit, alternating current generator of a recent design. While it is of compact construction and easy to turn, it is the most powerful five bar generator on the market. This generator will ring one 2500 ohm ringer through a line resistance of over 80,000 ohms. or will ring 40 such ringers through a line resistance of about 2,000 ohms. The latter is the equivalent of about 40 2,500 ohm. ringers on a thirty mile full metallic line of No. 12 N.B.S. iron wire. This generator is the result of years of special study and experiment.

### *SWITCH HOOK.*

14. Very compact and self-contained.

15. The best grade of platinum is used for all contacts.

THE NORTHERN ELECTRIC & MFG. CO., LTD.

16. All circuits are insulated from the frame.
17. All contact springs are mounted vertically so that dust cannot settle on the contacts—it falls right through.

*GENERAL.*

18. Note that the binding posts are mounted within the box so that the connections cannot be tampered with.
19. No unsoldering necessary to remove the transmitter arm—simply unscrew the terminals that hold the transmitter cords.
20. Terminals are provided so that a condenser may be connected in the receiver circuit at any time if desired.
21. With every set a complete wiring diagram is furnished that gives clear instructions as to how to connect the instrument for different classes of service.

Below we give a list of the various types of No. 1317 Telephone Sets, manufactured by this company for various classes of rural service:

*FOR LIGHT LOAD BRIDGING SERVICE  
WHERE CODE RINGING IS  
EMPLOYED.*

No. 1317-AH Telephone Set (replacing No. 1317-H) Set contains:

- 1—1000 ohm. Ringer (No. 38-A).
- 1—3 bar Generator (No. 22-A).
- 1—No. 140-A Switch Hook.



HOW TO BUILD RURAL TELEPHONE LINES

- 1—No. 13 Induction Coil.
- 1—No. 250 Transmitter.
- 1—No. 144 Receiver.
- 1—No. 92 Cord, 3 feet long.

Ten (10) or twelve (12) of these sets may be operated on a twelve (12) or fifteen (15) mile line of No. 12 N.B.S. iron wire.

**FOR MODERATE LOAD RURAL SERVICE  
WHERE CODE RINGING IS  
EMPLOYED.**

No. 1317-N Telephone Set (replacing No. 1317-A) Set contains:

- 1—1600 ohm. Ringer (No. 38-F).
- 1—5 bar Generator (No. 48-A).
- 1—No. 140-A Switch Hook.
- 1—No. 13 Induction Coil.
- 1—No. 250 Transmitter.
- 1—No. 144 Receiver.
- 1—No. 92 Cord, 3 feet long.

Thirty (30) of these sets may be operated on a twenty (20) mile line of No. 12 N.B.S. iron wire.

No. N1317-R Telephone Set (replaces No. 1317-F) Set contains:

- 1—1600 ohm. Ringer (No. 38-F).
- 1—5 bar Generator (No. 48-A).
- 1—No. 140-A Switch Hook.
- 1—No. 13 Induction Coil.
- 1—No. N1-A Condenser.
- 1—No. 250 Transmitter.

THE NORTHERN ELECTRIC & MFG. CO., LTD.

1—No. 144 Receiver.

1—No. 92 Cord, 3 feet long.

Thirty (30) of these sets may be operated on a twenty (20) mile line of No. 12 N.B.S. iron wire.

A  $\frac{1}{2}$  microfarad condenser (No. N1-A) is wired in series with the receiver to insure the ringing of the bells, even if a receiver is left off the hook.

**FOR MODERATE LOAD BRIDGING SERVICE WHERE PUSH BUTTON SYSTEM OF SIGNALING CENTRAL WITHOUT RINGING OTHER SUBSCRIBERS ON THE LINE IS USED.**

No. N1317-A Telephone Set—Set contains:

1—1600 ohm. Ringer (No. 38-F).

1—5 bar Generator (No. 48-A).

1—No. 140-A Switch Hook.

1—No. 13 Induction Coil.

1—No. N1-A Key.

1—No. 250 Transmitter.

1—No. 144 Receiver.

1—No. 92 Cord, 3 feet long.

Thirty (30) of these sets may be operated on a twenty (20) mile line of No. 12 N.B.S. iron wire.

No. N1317-F Telephone Set—Set contains:

1—1600 ohm. Ringer (No. 38-F).

1—5 bar Generator (No. 48-A).

1—No. 140-A Switch Hook.

1—No. 13 Induction Coil.

1—No. N1-A Key.

## HOW TO BUILD RURAL TELEPHONE LINES

- 1—No. N1-A Condenser.
- 1—No. 250 Transmitter.
- 1—No. 144 Receiver.
- 1—No. 92 Cord, 3 feet long.

Thirty (30) of these sets may be operated on a twenty (20) mile line of No. 12 N.B.S. iron wire.

A  $\frac{1}{2}$  microfarad condenser (No. N1-A) is wired in series with the receiver to insure the ringing of the bells, even if a receiver is left off the hook.

### **FOR HEAVY LOAD RURAL SERVICE WHERE CODE RINGING IS EMPLOYED.**

No. 1317-P Telephone Set (replacing No. 1317-E) Set contains:

- 1—2500 ohm. Ringer (No. 38-B).
- 1—5 bar Generator (No. 48-A).
- 1—No. 140-A Switch Hook.
- 1—No. 13 Induction Coil.
- 1—No. 250 Transmitter.
- 1—No. 144 Receiver.
- 1—No. 92 Cord, 3 feet long.

Forty (40) of these sets may be operated on a thirty-five (35) mile line of No. 12 N.B.S. iron wire.

No. N1317-S Telephone Set (replacing No. 1317-G) Set contains:

- 1—2500 ohm. Ringer (No. 38-B).
- 1—5 bar Generator (No. 48-A).
- 1—No. 13 Induction Coil.
- 1—No. N1-A Condenser.

THE NORTHERN ELECTRIC & MFG. CO., LTD.

1—No. 250 Transmitter.

1—No. 144 Receiver.

1—No. 92 Cord, 3 feet long.

Forty (40) of these sets may be operated on a twenty-five (25) mile line of No. 12 N.B.S. iron wire.

A  $\frac{1}{2}$  microfarad condenser (No. N1-A) is wired in series with the receiver to insure the ringing of the bells, even if a receiver is left off the hook.

**FOR HEAVILY LOADED BRIDGING SERVICE WHERE PUSH BUTTON SYSTEM OF SIGNALING CENTRAL WITHOUT RINGING OTHER SUBSCRIBERS ON THE LINE IS USED.**

No. N1317-E Telephone Set—Set contains:

1—2500 ohm. Ringer (No. 38-B).

1—5 bar Generator (No. 48-A).

1—No. 140-A Switch Hook.

1—No. 13 Induction Coil.

1—No. N1-A Key.

1—No. 250 Transmitter.

1—No. 144 Receiver.

1—No. 92 Cord, 3 feet long.

Forty (40) of these sets may be operated on a twenty-five (25) mile line of No. 12 N.B.S. iron wire.

No. N1317-G Telephone Set—Set contains:

1—2500 ohm. Ringer (No. 38-B).

1—5 bar Generator (No. 48-A).

1—No. 140-A Switch Hook.



# MICROCOPY RESOLUTION TEST CHART

(ANSI and ISO TEST CHART No. 2)

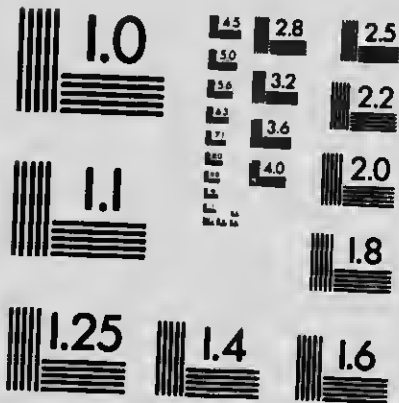

**APPLIED IMAGE Inc**

1653 East Main Street  
Rochester, New York 14609 USA  
(716) 482 - 0300 - Phone  
(716) 288 - 5989 - Fax

## HOW TO BUILD RURAL TELEPHONE LINES

- 1—No. 13 Induction Coil.
- 1—No. N1-A Key.
- 1—No. N1-A Condenser.
- 1—No. 250 Transmitter.
- 1—No. 144 Receiver.
- 1—No. 92 Cord, 3 feet long.

Forty (40) of these sets may be operated on a twenty-five (25) mile line of No. 12 N.B.S. iron wire.

A  $\frac{1}{2}$  microfarad condenser (No. N1-A) is wired in series with the receiver to insure the ringing of the bells, even if a receiver is left off the hook.

## CHAPTER VII.

*Rules for Wires Crossing Railways—General Order  
of Canadian Board of Railway Commis-  
sioners—Dated Oct. 7th, 1909—*

*Signed by Hon. J. P. Mabee,  
Chief Commissioner.*

**N**OTICE to Applicants: Send to the Secretary of the Board with the application, three copies of a drawing containing *plan* and *profile* views of the crossing. Also send proof that the Railway Company has been served with a copy of the application and drawing.

**MAKE THE DRAWING SHOW:—**

- (a) The location of the poles or towers, or the location of the underground conduit in relation to the track; the dimensions of poles or towers; and the material or materials of which they are made.
- (b) The proposed number of wires or cables, the distances between them and the track, and the method of attaching the conductors to the insulators.
- (c) The location of all other wires to be crossed, and their supports.
- (d) The maximum potential, in volts, between wires, the potential between the wires and the ground, and the maximum current, in amperes, to be transmitted.
- (e) The kinds and sizes of wires or conductors to be used at the crossing.



HOW TO BUILD RURAL TELEPHONE LINES

(f) On circuits of 10,000 volts, or over, the method of protecting the conductors from arcs at the insulators.

(g) The number of insulators supporting the conductors at the crossing. (See also "J" in Specifications.)

N.B.—Place a distinguishing name, number, date and signature upon the drawing. Mark the exact location of the proposed crossing upon the drawing, so that this crossing can readily be identified.

"A."

STANDARD CONDITIONS AND SPECIFICATIONS FOR WIRE CROSSINGS.

(Adopted and confirmed by Order of the Board No. 8392, dated October 7th, 1909.)

*PART 1:—OVER-CROSSINGS.*

CONDITIONS:—

1. The applicant shall, at its or his own expense, erect and place the lines, wires, cables, or conductors authorized to be constructed across the said railway, and shall at all times, at its own expense, maintain the same in good order and condition and at the height shown on the drawing, and in accordance with the specifications hereinafter set forth, so that at no time shall any damage be caused to the Company owning, operating, or using the said railway, or to any person lawfully upon or using the same, and shall use all necessary and proper means to prevent any such lines, wires, cables, or conductors from sagging below the said height.

THE NORTHERN ELECTRIC & MFG. CO., LTD.

2. The applicant shall at all times wholly indemnify the Company owning, operating, or using the said railway, of, from, and against all loss, cost, damage, and expense to which the said railway company may be put by reason of any damage or injury to person or property caused by any of the said wires or cables or any works or appliances herein provided or not being erected in all respects in compliance with the terms and provisions of this order, as well as any damage or injury resulting from the imprudence, neglect, or want of skill of the employees or agents of the applicant.

3. No work shall at any time be done under the authority of this order in such a manner as to obstruct, delay, or in any way interfere with the operation or safety of the trains or traffic of the said railway.

4. Where, in effecting any such crossing, it is necessary to erect poles between the tracks of the railway, the applicant, before any work in connection with such crossing is begun, shall give the railway company owning, operating, or using the said railway, at least seventy-two hours' prior notice thereof in writing, and the said railway company shall be entitled to appoint an inspector, under whose supervision such work shall be done, and whose wages, at a rate not to exceed three dollars per day, shall be paid by the applicant. When the applicant is a municipality and the crossing is on a highway under its jurisdiction, the wages of the inspector shall be paid by the railway company.

## HOW TO BUILD RURAL TELEPHONE LINES

4—a. It shall, not, however, be necessary for the applicant to give prior notice in writing to the railway company as above provided in regard to necessary work to be done in connection with the repair or maintenance of the crossing, when such work becomes necessary through an unforeseen emergency.

5. Where wires or cables to be erected across the railway are to be carried above, below, or parallel with existing wires, at the crossing, either within the span to be constructed across the railway or within the span next thereto on either side, such additional precautions shall be taken by the applicant as an engineer of the Board shall consider necessary.

6. Nothing in these conditions shall prejudice or detract from the right of the company owning, operating, or using the railway to adopt at any time the use of electric or other motive power, and to place and maintain over, upon, or under its right of way, such poles, lines, wires, cables, pipes, conduits, and other fixtures and appliances as may be necessary or proper for such purpose. Liability for the cost of any removal, change in location or construction of the poles, lines, wires, cables, or other fixtures or appliances erected by the applicant over or under the tracks of the said railway company, rendered necessary by any of the matters referred to in this paragraph shall be fixed by the Board on the application of any party interested.

7. Any disputes arising between the applicant and the said railway company as to the manner in which

THE NORTHERN ELECTRIC & MFG. CO., LTD.

the said wires or cables are being erected, placed, maintained, used, or repaired, shall be referred to an engineer of the Board, whose decision shall be final.

8. The wires or cables of the applicant shall be erected, placed and maintained across the said railway in accordance with the drawing approved by the Board and the specifications following. If the drawing and specifications differ, the latter shall govern unless a specific statement to the contrary appears in the Order of the Board.

9. In every case in which the line of a railway company shall be constructed under the wires or cables of a telegraph or telephone company, the construction of the telegraph or telephone company shall be made to conform to the foregoing specifications, and any changes necessary to make it so conform shall be made by the telegraph or telephone company at the cost and expense of the railway company.

*OVER-CROSSINGS.*

*SPECIFICATIONS:—*

A. LABELLING OF POLES.—Poles, towers, or other wire-supporting structures on each side of and adjacent to railway crossings, to be equipped with durable labels showing (a) the name of the company or individual owning or maintaining them, and (b) the maximum voltage between conductors; the characters upon the labels to be easily distinguished from the ground.

## HOW TO BUILD RURAL TELEPHONE LINES

**B. SEPARATE LINES.**—Two or more separate lines for the transmission of electrical energy shall not be erected or maintained in the same vertical plane. The word "lines," as here used, to mean the combination of conductors and the latter's supporting poles, or towers, and fittings.

**C. LOCATION OF POLES, ETC.**—Poles, towers, or other wire-supporting structures to be located wherever possible a distance from the rail not less than equal to the length of the poles or structures used. Poles, towers, or other wire-supporting structures must under no consideration be placed less than 12 feet from the rail of a main line, or less than 6 feet from the rail of a siding. At loading sidings, sufficient space to be left for driveway.

**D. SETTING AND STRENGTH OF POLES.**—Poles less than 50 feet in length to be set not less than 6 feet and poles over 50 feet not less than 7 feet in solid ground. Poles with side strains to be reinforced with braces and guy wires. Poles to be at least 7 inches in diameter at the top. Mountain cedar poles to be at least 8 inches at the top. In soft ground poles must be set so as to obtain the same amount of rigidity as would be obtained by the above specifications for setting poles in solid ground. When the crossing is located in a section of the country where grass or other fires might burn them, wooden poles to be covered with a layer of some satisfactory fire-resisting material, such as concrete at least two inches thick, extending from the butt of the pole for

THE NORTHERN ELECTRIC & MFG. CO., LTD.

a distance of at least 5 feet above the level of the ground. Wooden structures to have a safety factor of five.

**E. SETTING AND STRENGTH OF OTHER STRUCTURES.**—Towers or other structures to be firmly set upon stone, metal, concrete, or pile footings or foundations. Metal and concrete structures to have a safety factor of 4.

**F. LENGTH OF SPAN.**—Span must be as short as possible consistent with the rules of setting and locating of poles and towers.

**G. FITTINGS OF WOODEN POLES FOR TELEGRAPH, OR LOW TENSION LINES.**—The poles at each side of a railway must be fitted with double cross-arms, dimensions not less than 3 inches by 4 inches, each equipped with  $1\frac{1}{4}$  inch hardwood pins nailed in arms or some stronger support and with suitable insulators; cross-arms to be securely fastened to the pole in a girth by not less than a  $\frac{3}{8}$ -inch machine-bolt through the pole; arms carrying more than two wires or carrying a cable must be braced by two stiff iron or substantial wood braces fastened to the arms by  $\frac{3}{8}$ -inch or larger carriage bolts, and to the pole by a  $\frac{3}{8}$ -inch or larger bolt.

**H. FITTINGS OF ALL POLES, TOWERS, OR OTHER STRUCTURES.**—All wire-supporting structures to be equipped with fittings satisfactory to an engineer of the Board.

**I. GUARDS.**—Where cross-arms are used, an iron

## HOW TO BUILD RURAL TELEPHONE LINES

hook guard to be placed on the ends of and securely bolted to each. The hooks shall be so placed as to engage the wire in the event of the latter's detachment from the insulators.

**J. INSULATORS.**—All wires or conductors for the transmission of electrical energy across a railway to be supported by and securely attached to suitable insulators.

Wires or conductors in 10,000-volt (or higher) circuits, to be supported by insulators capable of withstanding tests of two and one-half times the maximum voltage to be employed under operating conditions. An affidavit describing the tests to which the insulators have been subjected and the apparatus employed in the tests shall be supplied by the applicant. The tests upon which reports are required are as follows:—

**J-a. PUNCTURE TEST.**—The insulators having been immersed in water for a period of 7 days, immediately preceding and ending at the time of the test, to be subjected for a period of five minutes to a potential of two and one-half (2.5) times the maximum potential of the line upon which they are to be installed.

**J-b. FLASH-OVER TEST.**—State the potential that was employed to cause arcing or flashing across the surface of the insulator between the conductor and the insulator's point of support when the surface was (1) dry, and (2) wet.

THE NORTHERN ELECTRIC & MFG. CO., LTD.

**K. HEIGHT OF WIRES: (a) LOW TENSION CONDUCTORS.**—The lowest conductor must not be less than 25 feet from top of rail for spans up to 145 feet;  $2\frac{1}{2}$  feet additional clearance of rails or other wires must be given for every twenty feet or fraction thereof additional length of span. The words "Low Tension," as here used, to mean conductors for telegraph, telephone, and kindred signal work, as well as conductors connected with grounded secondary circuits of transformers.

**K-b.** All primary conductors, ungrounded secondaries and railway feeders to be maintained at least 30 feet above the top of rail, except where special provisions are made for trolley wires.

**K-c.** High tension conductors, those between which a potential of 10,000 volts or over is employed, to be maintained at least 35 feet above the top of rail.

**L. CLEARANCES.**—Safe clearances between all conductors to be maintained at all times. The following distances to be provided wherever possible: at least 3 feet clearance between low tension wires; at least 5 feet between low tension wires, primaries, ungrounded secondaries, and railway feeders, employing less than 10,000 volts; at least 10 feet between high tension wires and all other lines.

**M. GUY WIRES.**—Guy wires at railway crossings to be at least as strong as 7 strand No. 16 Stub's or New British Standard gauge galvanized steel wire.



## HOW TO BUILD RURAL TELEPHONE LINES

and to be clearly indicated as guy wire on the drawing accompanying the application. One or more strain insulators to be placed in all guy wires; the lowest strain insulator to be not less than 8 feet above the ground.

**N. WIRES AND OTHER CONDUCTORS:—N-a.** Where open telephone, telegraph, signal or kindred low tension wires are strung across a railway this stretch to consist of copper wire not less than No. 13 New British Standard gauge, .092 inch in diameter. Wire to be tied to insulators by a soft copper tie-wire, not less than 20 inches in length and of the same diameter as line wire.

**N-b.** Where No. 9 B. W. G. or larger, galvanized iron wire is employed in a circuit, and where there is no danger of deterioration from smoke or other gases, the use of this wire may be continued at the crossing.

**N-c.** Where a number of rubber covered wires are strung across a railway, they may be made up into a cable by being twisted on each other or sewn with marline, which must be tied every three inches, and the whole securely fastened to the poles by marline.

**N-d.** Wires or conductors for the transmission of electrical energy for purposes other than telegraph, telephone, or kindred low tension signal work, to be comprised of at least 7 strands of material having a combined tensile strength equivalent to or greater than No. 4 Brown & Sharpe gauge hard drawn copper wire. These conductors to be maintained above

THE NORTHERN ELECTRIC & MFG. CO., LTD.

low tension wires at the crossing, to be free from joints or splices, and to extend at least one full span of line beyond the poles or towers at each side of the railway.

N-e. Wires or conductors subjected to potentials of 10,000 volts or over, to be reinforced by clamps, servings, wrappings, or other protection at the insulators to the satisfaction of an engineer of the Board.

N-f. Conductors for other than low tension work to have a factor of safety of 2 when covered with ice or sleet to a depth of 1 inch and subjected to a wind pressure of 100 miles per hour.

O. POSITIONS OF WIRES.—Wires or conductors of low potential to be erected and maintained *below* those of higher potential which may be attached to the same poles or towers.

P. TROLLEY WIRES.—Trolley wires at railway crossings to be provided with a trolley guard so arranged as to keep the trolley wheel or other running, sliding, or scraping device in electrical contact with them. The trolley wire, trolley guard, and their supports to be maintained at least 22 feet 6 inches above the top of the rails.

Q. CABLE.—Cable to be carried on a suspension wire at least equivalent to 7 strands of No. 13 Stub's or New British Standard gauge galvanized steel wire. When cross-arms are used, suspension wire to be attached to a  $\frac{3}{4}$ -inch iron or stronger hook, or when fastened to poles to a malleable iron or stronger messenger hanger bolted through the poles, the cable

## HOW TO BUILD RURAL TELEPHONE LINES

to be attached to the suspension wire by cable clips not more than 20 inches apart. Rubber insulated cables of less than  $\frac{3}{4}$ -inch in diameter may be carried on a suspension wire of not less than 7 strands of No. 16 Stub's or New British Standard gauge galvanized steel wire. The word "cable" as here used, to mean a number of insulated conductors covered or bound together.

### *PART 2—UNDER-CROSSINGS.*

#### CONDITIONS:—

1. The line or lines, wire or wires, shall be carried across the railway in accordance with the approved drawing, and a pipe or pipes, conduit or conduits, shall, for the whole width of the right of way adjoining the highway, be laid at the depth called for by, and shall be constructed and maintained in accordance with, the specifications hereinafter set forth.
2. All work in connection with the laying and maintaining of each pipe or conduit, and the continued supervision of the same, shall be performed by, and all costs and expenses thereby incurred be borne and paid by the applicant; but no work shall at any time be done in such manner as to obstruct, delay, or in any way interfere with the operation or safety of the trains, traffic, or other work on the said railway.
3. The applicant shall at all times maintain each pipe or conduit in good order and condition, so that at no time shall any damage be caused to the prop-

THE NORTHERN ELECTRIC & MFG. CO., LTD.

erty of the railway company, or any of its tracks be obstructed, or the usefulness or safety of the same for railway purposes be impaired, or the full use and enjoyment thereof by the said railway company be in any way interfered with.

4. Before any work of laying, removing, or repairing any pipe or conduit is begun, the applicant shall give to the railway company at least seventy-two hours prior notice thereof, in writing, accompanied by a plan and profile of the part of the railway to be affected, showing the proposed location of such pipe or conduit and works contemplated in connection therewith, and the said railway company shall be entitled to appoint an inspector to see that the applicant, in performing said work, complies, in all respects, with the terms and conditions of this order, and whose wages, at a rate not exceeding \$3.00 per day, shall be paid by the applicant. When the applicant is a municipality and the crossing is on a highway under its jurisdiction the wages of the inspector shall be paid by the railway company.

4-a. It shall not, however, be necessary for the applicant to give prior notice in writing to the railway company, as above provided, in regard to necessary work to be done in connection with the repair or maintenance of the crossing when such work becomes necessary through an unforeseen emergency.

5. The applicant shall, at all times, wholly indemnify the company owning, operating, or using the said railway of, from, and against all loss, costs, dam-

## HOW TO BUILD RURAL TELEPHONE LINES

age, and expense to which the said railway company may be put by reason of any damage or injury to person or property caused by any pipe or conduit, or any works or appliances herein, or in the order authorizing the work provided for, not being laid and constructed in all respects in compliance with the terms and provisions of these conditions, or if, when so constructed and laid, not being at all times maintained and kept in good order and condition and in accordance with the terms and provisions of said order, or any order or orders of the Board in relation thereto, as well as any damage or injury resulting from the imprudence, neglect, or want of skill of any of the employees or agents of the applicant.

6. Nothing in these conditions shall prejudice or detract from the right of any company owning, or operating or using the said railway to adopt, at any time, the use of electric or other motive power, and to place and maintain upon, over, and under the said right of way such poles, wires, pipes and other fixtures and appliances as may be necessary or proper for such purposes. Liability of the cost of any removal, change in location or construction of the pipes, conduits, wires, or cables constructed or laid by the applicant rendered necessary by any of the matters referred to in this paragraph, shall be fixed by the Board on the application of the party interested.

7. Any dispute arising between the applicant and the company owning, using, or operating said railway as to the manner in which any pipe or conduit, or any

THE NORTHERN ELECTRIC & MFG. CO., LTD.

works or appliances herein provided for, are being laid, maintained, renewed, or repaired, shall be referred to the engineer of the Board, whose decision shall be final and binding on all parties.

*UNDER-CROSSINGS.*

SPECIFICATIONS:—

A.A. CONDUIT.—Vitrified clay, creosoted wood, metal pipe, or fibre conduit may be used.

B.B. DEPTH.—The excavation to be of sufficient depth to allow the top of the duct to be at least 3 feet below the bottom of the ties of the railway track.

C.C. LAYING.—The conduit or duct to be laid on a base of 3 inches of concrete, mixed in proportion, 1 of cement, 3 of sand and 5 of broken stone or gravel. Where stone is used, such stone to be of a size that will permit of its passing through a 1-inch ring. After ducts are laid, the whole to be encased to a thickness of 3 inches on top and sides in concrete mixed in the same proportions as above.

Where the track is on an embankment a pipe may be driven through the latter.

D.D. FILLING IN.—The excavation must be filled in slowly and well tamped on top and side.

E.E. GUARD.—The excavation must at all times be safely protected by the applicant.

Approved,

(Sgd.) J. P. MABEE,  
Chief Commissioner.

October 7th, 1909.

Produced by  
J. J. Gibbons Limited, Toronto and Montreal







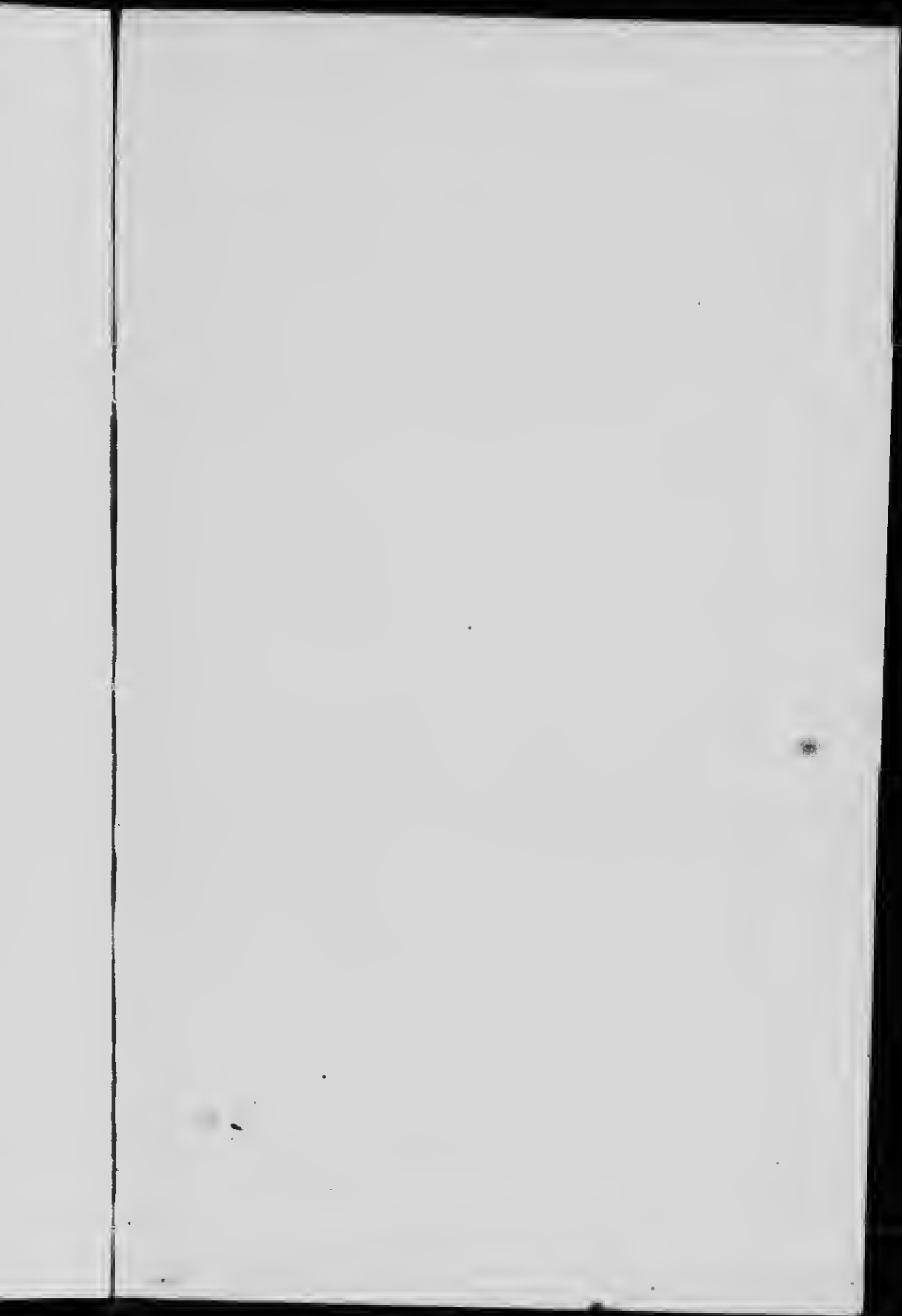

180  
170  

---

12600  
180  
30600  
29040  
1560

Walter Forrester,  
Rugby, Ont.  
Jan. 1911.



NLC BNC

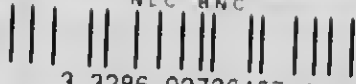

3 3286 02736467 4



