

Technical and Bibliographic Notes / Notes techniques et bibliographiques

The Institute has attempted to obtain the best original copy available for filming. Features of this copy which may be bibliographically unique, which may alter any of the images in the reproduction, or which may significantly change the usual method of filming, are checked below.

L'Institut a microfilmé le meilleur exemplaire qu'il lui a été possible de se procurer. Les détails de cet exemplaire qui sont peut-être uniques du point de vue bibliographique, qui peuvent modifier une image reproduite, ou qui peuvent exiger une modification dans la méthode normale de filmage sont indiqués ci-dessous.

- Coloured covers/  
Couverture de couleur
- Covers damaged/  
Couverture endommagée
- Covers restored and/or laminated/  
Couverture restaurée et/ou pelliculée
- Cover title missing/  
Le titre de couverture manque
- Coloured maps/  
Cartes géographiques en couleur
- Coloured ink (i.e. other than blue or black)/  
Encre de couleur (i.e. autre que bleue ou noire)
- Coloured plates and/or illustrations/  
Planches et/ou illustrations en couleur
- Bound with other material/  
Relié avec d'autres documents
- Tight binding may cause shadows or distortion  
along interior margin/  
La reliure serrée peut causer de l'ombre ou de la  
distorsion le long de la marge intérieure
- Blank leaves added during restoration may appear  
within the text. Whenever possible, these have  
been omitted from filming/  
Il se peut que certaines pages blanches ajoutées  
lors d'une restauration apparaissent dans le texte,  
mais, lorsque cela était possible, ces pages n'ont  
pas été filmées.
- Additional comments: /  
Commentaires supplémentaires:

- Coloured pages/  
Pages de couleur
- Pages damaged/  
Pages endommagées
- Pages restored and/or laminated/  
Pages restaurées et/ou pelliculées
- Pages discoloured, stained or foxed/  
Pages décolorées, tachetées ou piquées
- Pages detached/  
Pages détachées
- Showthrough/  
Transparence
- Quality of print varies/  
Qualité inégale de l'impression
- Continuous pagination/  
Pagination continue
- Includes index(es)/  
Comprend un (des) index
- Title on header taken from: /  
Le titre de l'en-tête provient:
- Title page of issue/  
Page de titre de la livraison
- Caption of issue/  
Titre de départ de la livraison
- Masthead/  
Générique (périodiques) de la livraison

This item is filmed at the reduction ratio checked below/  
Ce document est filmé au taux de réduction indiqué ci-dessous.

10X	12X	14X	16X	18X	20X	22X	24X	26X	28X	30X	32X
<input type="checkbox"/>	<input type="checkbox"/>	<input type="checkbox"/>	<input type="checkbox"/>	<input type="checkbox"/>	<input type="checkbox"/>	<input type="checkbox"/>	<input type="checkbox"/>	<input type="checkbox"/>	<input type="checkbox"/>	<input type="checkbox"/>	<input checked="" type="checkbox"/>

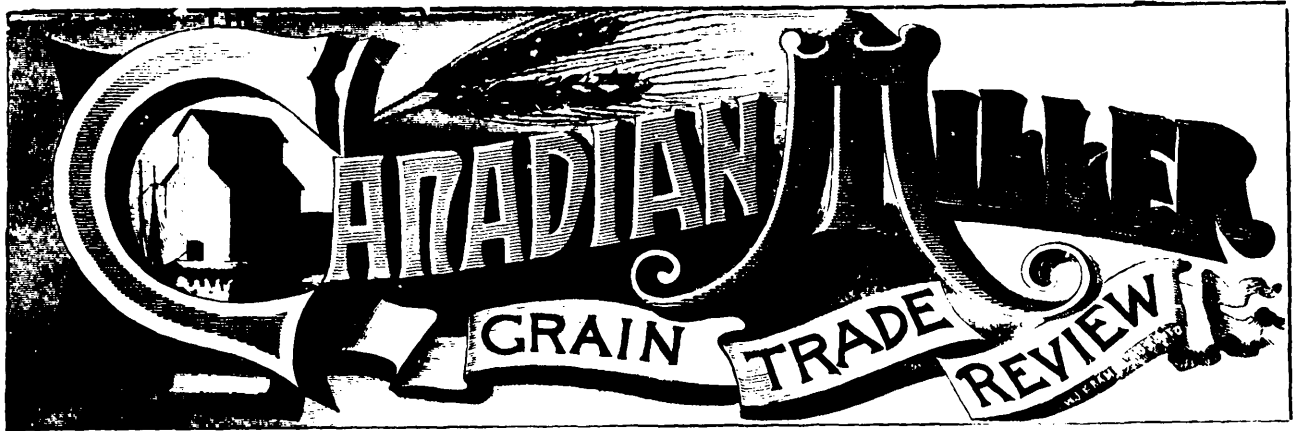

NEW SERIES "INDUSTRIAL AND MILLING NEWS"

Old Series, Vol. M. (Number 1)  
New Series, Vol. III (Number 1)

TORONTO, ONT., NOVEMBER, 1893

Published by the Year  
1893-1894



## MAGNOLIA METAL

IN USE BY

EIGHT LEADING GOVERNMENTS

BEST ANTI-FRICTION METAL FOR

Flour-mill, High-speed Engine, Dynamo, Rolling-mill, Steamship, Railroad, Saw-mill, Cotton-mill, Paper-mill, Woolen-mill, Silk-mill, Jute-mill, Rubber-mill, Sugar-mill, and all Machinery Bearings

## MAGNOLIA METAL CO.

Owners and Sole Manufacturers

London Office: 75 Queen Victoria Street  
Chicago Office: 41 Traders' Building  
Montreal Office: H. McLAREN & CO., Agents

74 Cortlandt St., NEW YORK

Automatic Arc Dynamos and Lamps  
Direct Current Incandescent Dynamos  
Alternating Current Incandescent Dynamos  
Transformers of High Efficiency  
Electric Motors All Electric Supplies

OUR record for the past ten years as  
Electrical Manufacturers guarantees  
the highest satisfaction

Ask our customers about cost of re-  
pairs on Ball apparatus, which for  
EFFICIENCY, ECONOMY  
SIMPLICITY and SAFETY  
are unexcelled.

AN ORDER  
SOLICITED

Send for new pamphlet  
of Motors and new  
Book of Testimonials

## THE BALL ELECTRIC LIGHT CO., LTD.

70 Pearl Street, TORONTO, ONT.

## A. WATTS & CO.

## BRANT ROLLER MILLS

BRANTFORD, ONT.

## GEO. McCULLOCH & CO.

Rapid City Roller Mills

RAPID CITY, MAN.

Hungarian Patents  
Strong Bakers'  
and Low Grade

SEND FOR SAMPLES AND PRICES

# RUBBER BELTING

MONARCH, RED STRIP AND LION BRANDS

MANUFACTURED BY

## THE GUTTA PERCHA & RUBBER MANUFACTURING CO. OF TORONTO.

OFFICE 516 BAYVIEW ST. TORONTO

FACTORY AT PARADISE, ONT.

### KENT MILLS

CHATHAM, ONT.

"KENT MILLS"

"THAMES"

"ELGIN"

"SWEET HOME"

"BUDGET"

CORNMEAL

BEANS

Middlings, Bran, Corn, Chopped Feed

### AYLMER MILLS

AYLMER, ONT.

High Grade Flour

Second Grade Flour

Low Grade Flour

Straight Kiln-Dried  
Granulated Sunrise, Kiln-Dried

Prime Medium  
Hand-Picked Medium

SEND FOR SAMPLES  
AND PRICES

N. H. STEVENS, Chatham, Ont.

ESTABLISHED 1856

## The J. G. McLaren Belting Co.

MONTREAL

# BELTING

MANUFACTURED FROM

## IMPORTED OAK-TANNED LEATHER

EVERY BELT GUARANTEED

TORONTO:

70 YORK STREET

# THE GOLDIE & MCGULLOGH GO., LTD.

## High Grade Modern Flour Milling

**T**HE science of milling has of late made very rapid progress, and we invite all who aim at having the best machinery in this line to investigate our system. For general excellence of design, workmanship and material, and for attaining the very best results, we claim that our manufactures in this line are not anywhere surpassed.



### New Mills Erected and Old Mills Remodelled

OF EVERY STYLE AND CAPACITY, UNDER THE SUPERVISION OF A THOROUGHLY PRACTICAL MILLWRIGHT AND MILLER



**Bolting Cloth** OF SUPERIOR QUALITY,  
AND

**General Mill Furnishings** ALWAYS ON HAND

... ORDERS PROMPTLY FILLED ...

### WE ALSO MANUFACTURE

The Wheelock Improved Automatic Engine, which we claim to be unsurpassed.  
Boilers and all appliances in connection therewith. Turbine Wheels.  
Wood-working Machinery. Sawmill Machinery. Shingle and Stave Machinery.  
Wool Machinery. Patent Wood Rim Split Pulleys.  
Fire and Burglar Proof Safes, Vault Doors, etc., etc.

CIRCULARS AND FULL PARTICULARS IN EVERY DEPARTMENT FURNISHED ON APPLICATION

# GALT, ONT.



STEAM BOILER INSPECTION  
AND INSURANCE DEPARTMENT

OF THE

Steam Boiler and Plate Glass  
Insurance Company of Canada

James Laut, Manager



- - DIRECTORS - -

- |  |   |   |   |                                  |                |
|--|---|---|---|----------------------------------|----------------|
| E. JONES PARKE, Q.C.   | - | - | - | -                                | PRESIDENT      |
| F. A. FITZGERALD, Esq., President Imperial Oil Co.                 | - |   |   |                                  | VICE-PRESIDENT |
| HON. DAVID MILLS, Q.C., M.P., Ex.-Minister of the Interior         |   |   |   |                                  |                |
| JOHN MORISON, Esq., Ex-Gov. British America Assurance Co., Toronto |   |   |   |                                  |                |
| T. H. PURDOM, Esq., Barrister, London                              |   |   |   |                                  |                |
| J. H. K'LEY, Consulting Engineer                                   |   |   |   | JOHN FAIRGRIEVE, Chief Inspector |                |



HEAD OFFICE, MASONIC TEMPLE, LONDON, ONT.

Authorized Capital, \$500,000

Subscribed Capital, \$200,000

Full Government Deposit

Have your Boiler inspected and insured. It pays to know you are right.  
Will your Boiler stand the pressure at its weakest point? Can you judge it?  
The man who handles steam handles power.  
As its danger increases, the knowledge necessary to protect yourself and property against that danger should be greater.  
Know that you are right. Inspection is the best investment.  
Do you use a high pressure?  
Your engineer should be a skilled man.  
Determine the power of your Boiler by inspection. Insure its safety by inspection and insurance.  
When were your Boilers last inspected by a competent engineer?  
Do you know what pressure your Boilers can safely stand?  
Is your Steam Gauge registering the correct pressure?  
Are your Water Gauges free and in good working order?

Is your Safety Valve working properly?  
Do not trust to luck, the unexpected generally happens. Avoid the calamity of an explosion.  
Protect life and property by taking out one of our Inspection and Insurance Policies.  
This Company insures Boilers against explosions, and causes inspections to be made by competent engineers. Inspection of your Boiler is the best guarantee of its safety. Our inspectors give advice and instructions wherever necessary to those in charge of boilers, which is of advantage to the owners, and results in greater economy, knowledge, and safety.  
Economy in fuel, in repairs, and in the length of time a boiler lasts.  
Knowledge how a boiler should be managed, and relieving the owner of responsibility.  
Safety because being kept in order the best results are obtained, and if an explosion occurs you have done what you could.

WORLD



No. 1 with Stand

BEATERS

# THE GENUINE PRINZ COCKLE MACHINES



Unique in Principle

Effective in Operation

Unapproachable in Results

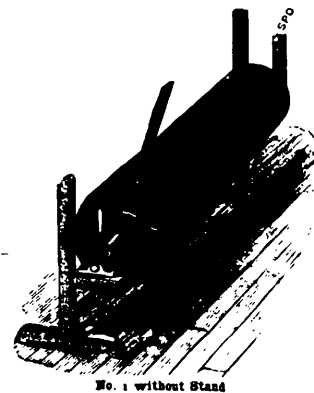
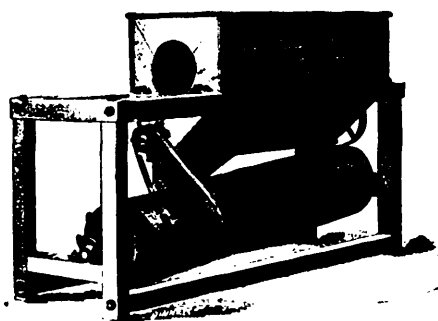

No. 1 without Stand

Steel Reels don't wear out. Peculiar Indentation makes Perfect Separation

The Inventor, Mr. Prinz, has studied the secret of grain cleaning, and followed every step with expensive experiments for about 15 years, and the machines now offered are complete in every detail, and guaranteed to do better work than any machine on the market

## PEERLESS MACHINES FOR MODERN WANTS

Two-thirds of the mills in Minneapolis, and all the mills in Milwaukee, and about a thousand all over the country, are using the "PRINZ"

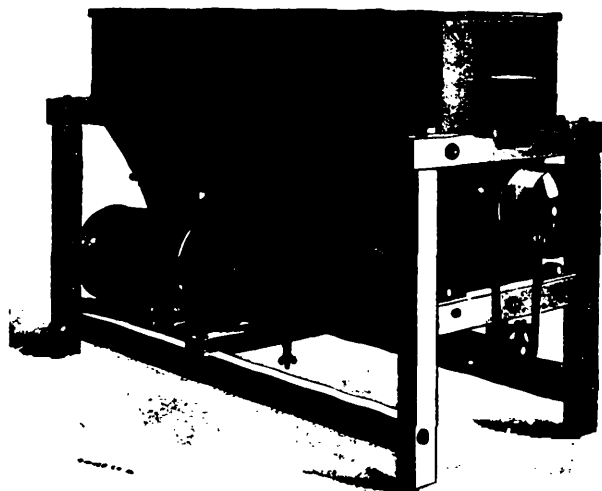
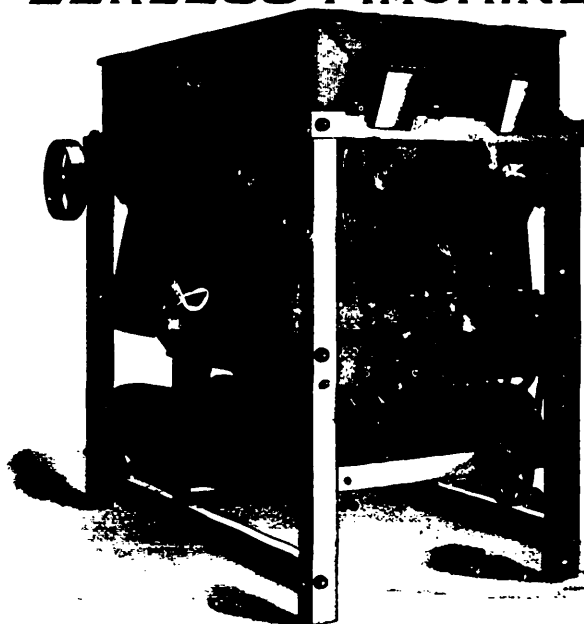

Manufactured for Canada trade, under license from Faustin Prinz, solely by

# WM. & J. G. GREY 2 CHURCH ST. TORONTO

# THE CANADIAN MILLER

OLD SERIES, Vol. XI } NUMBER 11.  
NEW SERIES, Vol. III }

TORONTO, ONT., NOVEMBER, 1893

TERMS, \$1.00 PER YEAR  
(SINGULAR COPIES, 10 CENTS)

## THE HAGGENMACHER BOLTING MACHINE.

A NEW machine called the Plansifter is appearing on the market. This machine is creating such a lively interest among the millers that we feel justified in giving our readers a description of it, which was furnished to us by the sole manufacturer, The Plansifter Company of Canada Ltd., Stratford, Ont., who are introducing the machine in Canada.

The inventor of this new bolting machine is Carl Haggennmacher, a prominent and wealthy miller in Budapest, Hungary. He is a man with practical knowledge, well-known in the milling world for many successful inventions in flour milling machinery.

The Plansifter consists of a chest about 11 ft. long, 4 ft. wide and 16 in. high, and contains several frames or sieves arranged on top of each other.

This chest is suspended on four rods, a crank imparts to it, from below, a gyrating motion in such a manner that each point of the chest describes a perfect circle. By an ingenious device the stock in the machine is made to travel over the sieves forward, backward, or in any direction desired. By putting in an appropriate series of sieves the Plansifter scalps, grades the middlings ready for the purifiers, and finishes the flour ready to go to the packer, all in one machine.

The idea of Mr. Haggennmacher was to make a machine having the same action as a hand sieve or riddle. If chop is handled on a hand sieve it will be observed the darker and heavier parts of the chop are kept floating on the top, while the lighter parts that is, the white stock or flour fall through the meshes of the sieves and bearer. Upon this principle Mr. Haggennmacher claims that the gyrating sieves will make purer flour than any other machine under the same circumstances.

The advantages which the manufacturers claim for this machine, are: 1. Better work, that is, purer, and at the same time sharper, more gitty, flour than by any other bolting machine. 2. The extraordinary capacity in handling either the best or poorest stock. 3. The cloths are kept perfectly clean without the severe action of brushes, even when the softest material is being handled. 4. The whole machine, notwithstanding its enormous capacity, takes less cloth than one of the old-style reels and occupies little room. 5. It runs smoothly and only requires about 1½ horse-power to drive it. 6. It saves a number of spouts, elevators, conveyers, and diminishes the fire risk.

In view of the fact that over 2,100 Plansifters are in use in Europe and that the Pillsbury-Washburn Flour Milling Company, the Washburn-Crossby Company, and

the Humboldt Milling Company, all of Minneapolis, and John B. A. Kern & Sons, in Milwaukee, have secured the right to build enough machines to equip their entire mills, and also that over 270 of these machines have been put in operation in the United States within the last eighteen months, we are of the opinion that it would be to the interest of our Canadian millers to fully investigate this machine before doing any further remodeling in their mills. If the claims made by the manufacturer of this machine proves correct no miller can afford to be without them.

## HOW FLOUR IS MADE.

THE following description, taken from the St. Nicholas magazine, is designed for child readers, and is free from inaccuracies than one would perhaps expect from an article so prepared. "The noises on the inside of the mill are deafening. One who has

the fibrous or bran portions are more completely separated, and at last the bran comes out a clear, brownish husk with every particle of flour removed. The inside part of the kernel has meanwhile been going through a very interesting process. After the first grinding or breaking, it passes to a big six-sided revolving reel covered with a fine wire netting or sieve. Through this reel the inner portions of the kernels pass, coming out in what are called 'middlings,' a granulated mass which goes back to the rollers for another crushing. This process is repeated through five reels, all but the first being of silk. The last one has 120 threads to the lineal inch. The flour which comes out of the fifth reel, while white in hue, is yet not of the finest 'patent' grade, but is classed as 'bakers' or second grade flour. The middlings above referred to are purified by an interesting process. They are passed over by a fine wire sieve, through the upper part of which a strong current of air

is passed. This holds in suspension the tiny portions of fibrous matter which may have been in the flour, and at last, after this process of

middlings purifying has been very carefully carried out, the flour appears a spotless, snowy-white. The 'patent' flour, as it is called. In the process of grinding in this gradual and repeated way, the germ of the wheat, a tiny article, about the size of a mustard seed, is separated from the white flour. It is what one might call the life part of the wheat. If it were ground up it would not leave the 'patent' flour so white and powdery, so it is separated in one of the sievings and passes into the darker or lower grade flour. It contains, however, the best and most nutritious part of the wheat. The last thing that happens to the pulverized kernel before it is ready for market is the filling of barrels or sacks. Down many stories through a smooth

tube comes the white or 'patent' flour. Under the tube is the barrel or sack, as the case may be, and as it begins to fill a steel auger,

just the size of the barrel, bores down into the flour, packing it carefully and solidly beneath the broad blades."

## CURING BOILER INCrustATION BY PETROLEUM.

PETROLEUM, which is one of the most useful liquids in commercial use, has appeared in a new role. It is said that it affords the best remedy yet known for boiler incrustation. The petroleum is either squirted against the inside walls of the boiler after the latter has been cleaned, or it is added to the water of the boiler when full, so that when the water is slowly run off, the petroleum acts gradually on the sedimentary deposit, rendering it so loose and brittle that it can easily be removed by tools, or even by a powerful stream of water. So far no prejudicial action of the petroleum on the boiler plates has been noticed. It is said that the State Railways Administration in Prussia has adopted petroleum as an incrustations removing medium throughout the whole of its lines.

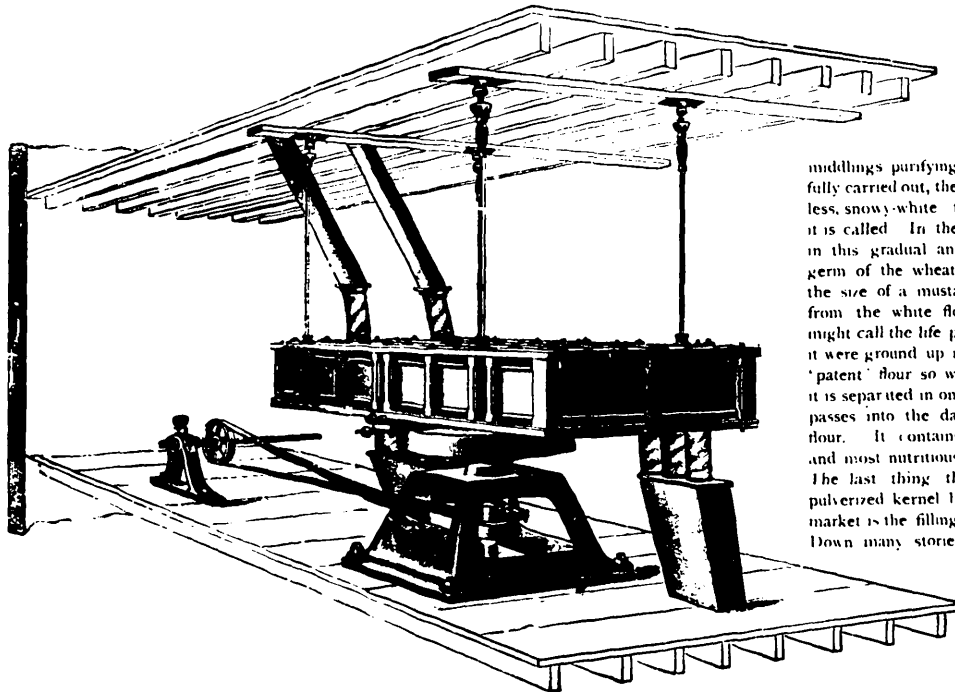

THE PLANSIFTER

never been in a flouting mill of the largest size cannot realize what a peculiar lot of noises are made by the machinery. As soon as the wheat enters the machine from the long spout which brings it down from the upper floor it falls between two rollers of iron 'chilled' iron they call it, and very hard iron it is, too. One of these rollers revolves rapidly, the other more slowly, in order that the separation of the coat, or bran, from the kernel may be more easily accomplished. The wheat first passes between rollers separated just enough to allow the coat to be crushed. It is then carried away to the top of the mill again, to a room where the sun vainly tries to shine in through the flour-coated windows far above the city's roofs. It next passes over a wire sieve which separates the bran from the kernel proper. This bran, which contains much of the flour material, again passes down and is ground once more, this process being repeated four times, making five grindings, each one finer than the one preceding it. Each time

THE NEWS.

CANADA.

- M. Creighton will build a new grist mill at Comber, Ont. It is said that 200 cars of wheat are daily being received at Fort William.

- Geo. Bull has purchased the interest of Geo. Hutton in the St. Albert, Man., grist mill

- A wheat train came to grief east of Rat Portage last week, a number of cars being spilled in the smash.

- A large grain warehouse has been erected at Bisswood, Man., by Geo. Hanna, and is now ready for use.

- E. A. Duncan has leased the farmers' elevator at Rapid City, Man., from the directors of the Company.

- C. H. Young, grist miller at Codrington, Ont., is in difficulty. His property, which was mortgaged, has been sold.

- Letters patent have been issued incorporating The Brandon Farmers' Elevator, Milling and Trading Company, limited.

- John Mackay, of Bowmanville, Ont., writes that business with him is very good, having a large number of orders ahead.

- Copeland & Sons' mills at Penetang and Midland, Ont., are running day and night, and yet they are behind with orders.

- Smith & Brigham, millers, Moosomin, Assa., have just completed the installation of an electric light plant in their premises.

- The Messrs. Moody, flour millers, of Orangeville, Ont., have purchased a new site and contemplate the erection of a big woolen mill.

- Charles Davies, a farmer living at Whitewood, Assa., this season grew 1,800 bushels of White Eyfe wheat, all of which weighed 69 pounds to the bushel.

The Peterborough Milling Company, we are informed, by one of its directors, don't do a milling business as a company. They merely buy, build, sell and rent.

Wilson & Co. is the style of a new firm of grain brokers lately established in Winnipeg. John Wilson is a grain buyer of Mark Lane, and the other, S. B. Flower comes from Brandon.

The movement of grain through the country, says the Manitoba Free Press of a recent issue, notwithstanding the low price of wheat, is on the increase, and the railroads are hauling twelve to sixteen carloads each every day.

- The stock of grain in store at Port Arthur, Ont., on the 28th October last was 1,129,672 bushels. During the following week there was received 337,561 bushels, and shipped 296,778 bushels, which left in store on the 4th November 1,430,455 bushels.

- J. T. Huber, of Berlin, Ont., who lost his glove and shoddy factory lately by fire, has purchased the flouring mill property of Mr. J. Cluthe, Doon, and will at once proceed to fit up the buildings with the necessary machinery, and as soon as completed will again commence business.

- The new flour mill at Melita, Man., erected by Peter Powell and John Ferguson, is nearing completion. The mill building is 36 by 48 feet, four stories high. The engine house is 36 by 24 feet, built of solid stone. The building will be lighted with electricity, and the plant generally is claimed to be a very complete one.

- The farmers' elevator at Neepawa, says the Herald, is having its capacity tested these days. Ennis's is almost full, so is Oglivie's. There were 35,000 bushels shipped from Neepawa during October. Cars are scarce, and just now it is becoming a serious question among buyers as to where they will store the large amount of grain that is daily coming in.

- John Carruthers, of Carp, Ont., has sold his roller mill to H. McElroy & Sons. The whole mill will be overhauled and put into first-class operation and will be kept running day and night, the estimated daily output of flour 75 to 100 barrels. A large elevator will be placed in conjunction with the mill which will be a great convenience to the farmers.

The Baltimore Corn and Flour Exchange have written to the Montreal Board of Trade asking for their co-operation in endeavoring to correct the present unsatisfactory methods of delivering grain from ships at European continental ports so that consignees would receive their proper proportion of shipments according to the conditions of the bills of lading.

The Commercial, Winnipeg, Man., says: "The 'Deil' appears to be 'amang' the millers, and they are giving the consumers cheaper flour than they ever had before. The recent cuts in prices have brought the local value of flour down to about a parity with prices of Manitoba flour east, and flour is comparatively cheaper in this market than ever before."

Winnipeg is to have a new flour making industry. The projector is a Mr. Geo. Rice, who has been a resident of the Prairie City for fourteen years. He has about completed a mill for crushing grain for feed and making the flour familiarly known as Graham flour. This flour he will make by taking No. 1 hard wheat, cleaning and grinding it just as it is, without taking anything from it or adding anything to it, and it will be known as Rice's process flour.

Canadian millers carried off some of the best awards made at the World's Fair. Among these were: Stephen Nairn, Winnipeg, Man.; S. H. Stevens, Chatham, Ont.; Whitlaw, Baird & Co., Paris, Ont.; John Steinsmuller, Walkerton, Ont.; D. M. Clean, Calgary, N.W.T.; Moose Mountain Trading Co., Cannington Manor, Assa.; J. Wilson, Ferguson, Ont.; E. O. Tilson, Tilsonburgh, Ont.; Western Milling Co., Regina, N.W.T.; Austin Mills, Austin, Man.; M. McLaughlin & Co., Toronto, Ont.; John Hull, Lakefield, Ont.; Brackman & Ker, Victoria, B.C.

The Oglivie Milling Co., Winnipeg, has issued a handsome folder circular, giving a list of testimonials from bakers who have used the manufactures of the company. The front page of the circular is a handsome piece of printing in color work. It gives cuts of the Winnipeg and Royal Mills owned by the company. Cuts are also given of bags of Oglivie's oatmeal and bakers brands of flour, showing the trade mark of these brands. The testimonials speak very highly of Oglivie's flours, particularly of the quality turned out since the improvements were made in the Winnipeg mill.

PERSONAL.

T. R. Wadsworth, the well-known miller of Weston, and director of the Imperial Bank, died suddenly on Monday 30th October, of apoplexy. He was superintending the erection of a new milldam, and at 3.30 o'clock went into the mill. He took the miller to come over to the store for some shipping orders. The miller went over five minutes later and found Mr. Wadsworth dead in the office. He had a newspaper in his hand. Mrs. Wadsworth was in Toronto meeting her son when Mr. Wadsworth's death occurred. He was a wealthy man and respected by a wide circle of business and financial men throughout the Dominion. He was born in Weston more than three score years ago and had lived all his life there. He succeeded in building up a large and prosperous flour milling business and became prominent in the management of several financial institutions. He occupied a place on the directorate of the Imperial Bank continuously since the organization of the bank in 1875. He attended the last board meeting on the Thursday previous to his death, and among those who most sincerely mourn his death are his fellow-directors, who valued highly his careful, prudent counsels and accord to him a full share of the success which has attended the Imperial during the twenty years of its history. He was also a director of the London & Canadian Loan and President of the Real Estate Loan Company of Toronto. He was very highly respected by all who knew him for the honorable, straightforward, character and for the soundness of his judgment. He was of a retiring disposition and did not seek prominence in public affairs, and the Reeve ship of his township is the only public office which he ever occupied.

AUSTRIAN OPERATIVE MILLERS.

At a recent meeting of Austrian operative millers, says The Miller, of London, Eng., a gloomy picture was drawn of the condition of labor in flour mills. One speaker maintained that even in some great merchant mills men were worked for 18 hours at a wage of 80 kreuzers (roughly 1s. 4d.). As for small country mills, there the worker was alleged to find no bowels of compassion. He might now and again snatch an hour's sleep, but any moment was liable to be roused by the bell which hung over his pallet, and was so arranged as to ring whenever the millstones with which its cord communicated should be running empty. In such mills the men were locked in for the night, and could hardly get away if a fire broke out.

Minor but substantial grievances were advanced in the shape of sleeping quarters reeking with damp, and choked in flour and dust. It was stated that in few country mills could an operative be found of more than thirty years of age. By that time the worker would be bowed and pigeon-breasted (a result of constantly carrying too heavy weights) and unfit for the hard work of a small flour mill.

Another speaker said that even in merchant mills of fair capacity regular hours were the exception, and that the blessing of a twelve-hours' shift could only be en-

joyed in a few large mills. There, however, the wages were very low on account of the young and unskilled men it was possible to employ. Several resolutions were passed before the meeting broke up. The general effect of which was to affirm the expediency of placing all flour mills without distinction under the operation of the Austrian factory law, which, if we are not mistaken, limits a shift to 12 hours. A protest was also raised against the indenture of apprentices before the age of sixteen.

BAD FOR HOLDERS OF WHEAT.

THE past two years have not been very profitable to many holders of wheat. Added to the various stories of the kind that have been made public of recent months comes the following from the Montreal Trade Bulletin: "Now we will refer to a lot of Canada spring wheat that missed a sale, and it is a lucky thing for the owner that it was only a single car. This lot of only 400 bushels has been held in this city since last July twelve-month, costing 75c. in the country, or about 80c. laid down here. About a year ago it could have been sold at 75c. in store here, but the owner was indignant at such a bid. It is only a few days since, however, that he came into the city to accept a bid of 60c. but it was too late; he put off the acceptance of that bid too long, and the buyer refused to take the wheat, as it had been discovered that it was slightly heated. As it was only a car load, the owner, of course, did not make much ado about it, although he sat down and figured up a loss of a little over \$200 on that single car. He calculated that the storage, interest and insurance on the car of wheat amounted to about 20c. per bushel."

THE BARLEY TRADE.

THE McKinley Bill, which went into force three years ago, has greatly lessened the growth of Canadian barley. Canada's largest export of barley a few years ago was in round numbers 12,000,000 bushels, but this was reduced to 4,000,000 in 1892-93. The production in this province in former years was from fifteen to twenty million bushels, but good authorities state that five millions is a good allowance for the past season and others say that three millions is good count. The barley this year is bright, but it lacks body, and consequently there is little prospect of doing an export trade with Britain. No shipments there are reported this year. As compared with British barley ours is much smaller and lighter in weight. The stock in store is only 28,700 bushels, as against 40,735 bushels a year ago and from 100,000 to 300,000 bushels in years gone by.

SHE WALKED OFF WITH TWO BARRELS OF FLOUR.

"WHEN you talk about strong men I can tell you a story," said a truckman. "It was before I was in the jobbing business that there lived in Lewiston a woman who could beat all the strong men from Samson to Cyr. She was in the old grocery store on the corner one day when the proprietor pointed to a couple of flour barrels, saying: 'Mary, if you'll carry them home I'll give them to you.' Sanborn, who was a truckman thirty years, and who sold out to James Cole, was there, and offered to bet that she couldn't carry one. 'Put them up on the counter,' she said, 'and I'll take them both.' Four men lifted the barrels up and she went up to them full of confidence, and resting the bottom of one on her right hip circled the barrel with one of her long arms and then swung around so as to grasp the other in the same way, and, as I live, she carried them out and along the street to a place 300 yards down the road, where one of them fell and upset her balance. You see, she rested them on her hips and didn't try to lift them by her back. The grocer gave her the flour."

No mill can have a fixed running capacity which has different grades of wheat to grind. The necessity of a fixed capacity in any mill is a fixed grade of wheat an exact quality. The treatment for hard, dry wheat, and that necessary for soft, tough wheat are radically different.

Advertise in CANADIAN MILLER. It pays.



THE saying is an old one, "that every mother crow thinks her own juvenile crow the blackest." It is human nature, and the mother crow is not always astray. Why should not the miller, who has given years of thought and experience to the construction of a mill, believe he has got the best mill the country can produce? Evidently this is the way Mr. H. A. Mulhern, of Peterboro', feels, and he is a man who knows a good deal about milling. I give you the words of a recent letter: "The machinery in our new mill has been running for some days and we start to grind tomorrow. We consider we have the most complete 600-barrel mill in the Dominion, and if anyone thinks otherwise we should be pleased to have him come and satisfy himself. The water wheels will give us 400 horse-power. All we have to do to increase to 800 barrels is to put in four more double sets of rolls. We have all other machinery in to handle the increase."

\* \* \* \*

Russian war days, and gala days these were for farmer and grain merchant, are recalled by the following incident: "E. M. Morphy, the veteran Yonge Street jeweller, was at the Woodbridge fair a few weeks ago, and while sauntering around the grounds was approached by an elderly farmer, who greeted him by name. "Really you have the advantage of me," said Mr. Morphy. "Why, Mr. Morphy, I bought this watch from you at the time of the Russian war," said the farmer, pulling out an ancient timepiece, "and in all the years since then it has not cost me a dollar for repairs." "Aye, aye," said Mr. Morphy, "you could well afford to buy a good watch then, for you were getting two dollars a bushel for wheat."

\* \* \* \*

A well-to-do business man met an old acquaintance in his trade who had a decidedly shabby and forlorn look. "Well, well! If this isn't Jones!" exclaimed the prosperous man. "I haven't seen you on 'Change for a long time." "I haven't been there," answered the shabby man. "Ah, retired from business?" "Not exactly: on the contrary, business has retired from me!" This is what someone has called the other way around. Circumstances over which one has no control will sometimes bring misfortune on the best and strongest of men. Business, however, retires from some men because they tire of looking properly after it. I am impressed in my association with the business community with the danger that lurks among some of the shrewdest men of getting into ruts and sticking there, allowing others who are more energetic to pass them in the race. Eternal vigilance is the price of success in business in all of its departments.

\* \* \* \*

"A very good business is being done in broken lots of Manitoba flours," said a well-known Toronto dealer. "These flours are preferred to Ontario brands," he continued, "as there is much more body in them. For instance, bakers can get from 66 to 67 loaves out of a barrel of Manitoba flour, while 60 is a large number from a barrel of Ontario wheat flour. In speaking of flour," the dealer said, "the price of bread is uppermost. Bakers must be making good profits just now in selling the four-pound loaf at 10 to 12 cents. Choice Manitoba patents sell at \$3.80 to \$3.90 per barrel, and counting 66 loaves to the barrel which sell, say at the lowest price, 10 cents, the gross revenue from a barrel would be \$6.60. The cost of baking and delivering is \$1 per barrel, so that the baker has a return of \$5.90 for every barrel bought at \$3.80 to \$3.90. Some allowance must be made for bad debts, for although the amounts are generally small, bakers make losses by giving credit."

Prof. Wm. Jago, representing the British National Association of Master Bakers, and who has been on a visit to the United States, is coming in for some sharp criticism, I observe, from several milling papers. The Modern Miller charges that this gentleman was brought to this country by a certain milling paper in Minneapolis, and to be used to boom the flours of a certain number of millers, who were willing to pay him to come, and pay him to take back their brands as the representative flour brands of this side of the Atlantic. These brands, it is alleged, will be almost altogether of spring-wheat flour, while the interests of winter-wheat millers are to be passed by. It is a serious charge to make against the journal in question of lending itself, if it did so, to questionable methods of the character intimated, while the reflection on our visitor is, perhaps, more condemnatory. It will be in order for these gentlemen to rise and explain, for it is to be said that the kindly welcome that was accorded to Prof. Jago by the milling firms of the country was on the supposition that his visit was to advance the common interest of exporters of American and Canadian flour, and to give British consumers an intelligent and somewhat comprehensive knowledge of the character of the flour manufacturer in this country.

\* \* \* \*

A trade contemporary takes kindly to a remark I made in this page a few months ago suggestive of laying hold of a trade pointer whenever one comes across it. The Helper, the journal referred to, says: "Now there is trade wisdom. And the wisdom of this progressive 'dusty' is shown not only in his 'lay hold of it,' but in his prompt publication of the pointer for the benefit of his craft. He is a simon-pure benefactor—a trade lifter—an intelligence spreader—a business promoter of a valuable sort. May his tribe increase." These pointers are not the monopoly of any particular few in the milling or any other trade. I have no hesitation in saying that out of the several thousands of readers of the CANADIAN MILLER every month there are scores who might occasionally send a pointer, a suggestion, a thought that would be practically helpful to their brother dusties. Are we lazy? Or is it selfishness that causes so many to hold back in this matter? I believe that it is just simply that men don't want to take the trouble of sitting down for a few minutes and with pen or pencil placing their thoughts on paper. Call that selfishness, or laziness, just as you like. The editor can be trusted to lick the ideas into shape if there is any concern as to the shape in which they may reach the paper. I am anxious to see a good budget of correspondence from millers this winter.

\* \* \* \*

W. W. Ogilvie has recently returned from a trip through the Northwest. Talking about the crops he said: "This year's crop in Manitoba and the Territories was of a very superior quality. The weather for harvesting and threshing, and for hauling the grain to elevator, has been exceedingly fine. The only drawback to the farmers are the low prices prevailing not only there, but throughout the world. This season's crop will grade at least seventy-five per cent. No. 1 hard—the best quality in the market. The yield, both in point of quality and otherwise, surpasses that of last year, and especially as frost rendered no damage. The east-bound movement of grain has begun. Thus far the receipts at my Montreal mills of this season's crop exceed 150,000 bushels, and we have also stored 330,000 bushels in the Fort William elevator. The daily deliveries at interior elevators in Manitoba and the Northwest now vary from 150,000 to 175,000 bushels per day. During my travels I noticed that the farmers are gradually engaging in mixed farming. This is a move in the right direction. There is also a tendency to locate on farm lands near Winnipeg. Of this city itself I cannot speak too highly. The improvement since last year is simply marvelous and augurs well for the future of that country. The population is increasing at a rapid rate, while there is no boom, building operations have been carried on this season on a very extensive scale. The city wears a solid and prosperous appearance. Everybody appears to be busy, and there is a notable absence of the idle element, which characterized affairs there for several years after the boom."

#### DIFFERENTIAL MOTION.

IN a paper read before the Pennsylvania Millers' State Association the following views are expressed by Mr. E. T. Butler on the subject of "Differential Motion":

"I believe I have shown in my remarks that we have from mills of different systems a large variety of products, varying in quality and quantity produced from a given amount of wheat. As a matter of course, the primal cause of this well-known discrepancy rests with the several flow sheets embodied in the plants. A flow sheet should represent each and every element of a mill plant, harmoniously organized, sufficiently explicit in every detail to enable a skilled millwright to arrange the same in a mill to the minutest details, because a slight break in the design somewhere may greatly impair the result. A bit of material traveling the wrong way; a machine running too slow, and so overcrowded; an excessive or insufficient differential in the rolls; something somewhere to destroy the harmony of the plan, will result in comparative disaster. This applies alone to a correct design improperly carried out, because it little reckons how the ordinary flow sheet is put together; the greatest departure from its design, if it can be said to have any, will be found an improvement.

The flow, then, is all-important. While some machines may have marked advantages over others of the same class, notably in roller mills with each roll operated directly from the power shaft, which so facilitates the different shades of differentials necessary to the success of a mill plant, yet the key to success is to be found in the flow, with all its many elements of success or failure so closely related and blended together. To enumerate these different elements in the order of their importance, I would place corrugations at the head of the list. Next in order naturally follow differentials, then separations, and behind all these the operator, because no man, however skilled in handling a mill, can produce the best possible results when any of these are lacking.

To come at once without further preliminaries to the subject assigned me, which I have placed second in order of importance, I would say at the outset that any and all combinations of differentials will produce results good, bad or indifferent. This may account in a measure for the discrepancy I have mentioned. The reason why errors are so persistently retained where they so often occur is because the effect produced seldom manifests itself at the locality of the cause, but always further along in the system where they are sought for and, of course, never found. Frequently, too, this inseparable combination, cause and effect, are as far separated as the first break and the flour barrel. Is it any wonder, then, that they escape detection? This applies particularly to the wheat breaks, where good, bad and indifferent work appears so nearly alike in the blended products in the hand, that the most skilled often fail to detect the slight shades of difference in the work of the breaks.

When I place differentials second in order of importance of all the elements that combine to produce a milling plant, I do so with full confidence in my position, having repeatedly experimented and proved the different combinations along a scale, extending each way, of minimum and maximum limit of usefulness, beginning at 1-5 to 1, through all the intermediate shades of differentials best suited to the several reductions, up to 5 to 1. This is the absolute limit of usefulness, and I contend that no mill can attain the best possible results unless it employs all of these, with the means of quickly changing the maximum differential, best suited to dry, hard wheats, to say, 3 to 1 for damp, soft wheats. This may seem paradoxical, but it is nevertheless true, that by changing differentials alone on some of the wheat breaks, other elements embodied in a system being correct, a short or a broad bran can be produced at will. Need I say to you which is the best work?

These differentials apply alike to all lengths of system from the four-reduction mill (two on wheat and two on middlings), the shortest possible successful roller plant to any number of reductions—which, however, should never exceed five breaks on wheat.





PUBLISHED ON THE FIFTEENTH OF EACH MONTH

BY  
**ARTHUR G. MORTIMER**

OFFICE:  
75 CANADA LIFE ASSURANCE BUILDING  
TORONTO, ONTARIO

TERMS OF SUBSCRIPTION:

One Copy One Year, in advance \$3.00  
One Copy Six Months, in advance 2.00  
Foreign Subscriptions, \$5.00 a Year

ADVERTISING RATES FURNISHED ON APPLICATION

J. S. ROBERTSON, EDITOR.

THE CANADIAN MILLER AND GRAIN TRADE REVIEW caters to the Miller and all his associations, and to the Grain Dealer with all his interests.

The only paper of the kind in Canada, containing full and reliable information on all topics touching our patrons, and unconnected as an organ with any manufacturing company, we will always be found honestly and earnestly endeavoring to promote the interests of our subscribers.

Correspondence is invited from millers and millwrights on any subject pertaining to any branch of milling or the grain and flour trade.

#### ARE ONTARIO MILLERS LOSING MONEY?

CURRENCY is being given to a statement made by the Montreal Trade Bulletin, that the depression in milling operations in Ontario is having the effect of depreciating milling property, seriously, and causing not a few to drop out of the business. An instance is given of a practical miller, who is said to have put \$10,000 into a mill in the province and in a short time dropped every cent. He then stepped out and left the mortgagee to take possession of the property and make all he could out of it. The further statement is made that a number of Ontario millers are mortgaged up to the hilt, as a result of the past two years' unprofitable trade.

It is a fact there is no use in glossing over that there have been better times for millers than those of the past two years. It is equally true, that the same remark can be applied to every branch of trade, without exception. Where is the business that has not suffered, and suffered seriously, from the trade depression of the past two years? A practical miller may have lost \$10,000 in milling during this period. We do not know to whom reference is made by the Bulletin. It would be an easy matter to mention the names of those in various branches of business, manufacturing and mercantile, who have lost more than one \$10,000 in their undertakings of the past few years. With some knowledge of the milling trades of Ontario we venture the statement, taking into account the amount of capital invested in the business, that there have been fewer failures during the past two years in milling than perhaps in any other branch of trade.

Flour has been low in price and the export markets, at least, have been glutted with mill products, making sales difficult and risky. Millers have had to exercise their best judgment in the management of their affairs, watching the small economies as they never watched them before. But as a result of these methods of management they have kept their mills grinding, and in not a few instances we could name, money has been made by the miller. It seems reasonable to suppose that the man who lost \$10,000 in milling in the short time alleged by the Bulletin must have been exceedingly impracticable in some important matters.

Within the past two years there has been no considerable extension of milling properties in Ontario. There might be named the large Campbell mill at West Toronto Junction, the new mill erected by the Peterborough Milling Company, of Peterborough, an important addition to the Royal mills of M. McLaughlin & Co., of this city, and others. Besides this, the mill-furnisher has had an active year in placing new and improved machinery and enlarging the capacity of many of the best mills of the country.

These are not omens of failure. We are aware that the complaint is sometimes made that mill-building is being overdone in the province, but this is to be said that the men who have branched out most largely dur-

ing the past few years are known for their knowledge of the milling situation; and their ability as practical millers, as well as shrewd men of business, is not to be questioned.

It would be a mistake to make any statement at the present time, in view of the general financial stringency, that would encourage any unnecessary expansion of milling operations. Rather it is a time for everyone to take in sail, at least to go it slow. But saying this much, we think that a careful analysis of the milling trades in Ontario give evidence that the Montreal Trade Bulletin has not stated correctly the real position of flour-milling in the Province.

#### EDITORIAL NOTES.

In answer to the conundrum: Shall we go on growing wheat? a cotemporary answers: Shall ducks go swimming? Shall gravitation go on acting? Shall hungry persons go on eating? Shall toppers go on boozing? The answer is capable of indefinite expansion and extension.

The flour trade of Boston do not propose to fall into the hole that holds not a few dealers in other places, and have adopted a regulation requiring that all flour sold in the market shall be ordered out in thirty days or less. The iniquitous practice of dating ahead has probably had its strongest grip in some of the old country cities, notoriously London and Liverpool, but it is by no means confined to these. Wherever it has an existence it ought to be frowned down and dealt with in as vigorous a fashion as is now proposed by Bostonians.

We made some comment in last month's MILLER on the probabilities of the Argentine Republic becoming an active wheat competitor in the immediate future. Confirmatory of this view the London correspondent of the Northwestern Miller says: "One of the most extraordinary features of the past season has been the abundance of Argentine wheat. The exports from that republic have, in fact, for the first time, exceeded those of India, the total exports from Argentine in the six months, ended June 30, being about 3,200,000 qrs., against 1,700,000 qrs. in the corresponding half year of 1892. There have, however, been loud complaints among receivers here, regarding the quality of this wheat, which have tended to make it the lowest-priced wheat on the market, with the single exception of Varna or Bulgarian wheat."

WITHIN recent years a number of farmers' elevators have been erected in Manitoba and the Northwest, and operated as joint stock concerns. The theory seemed to be that proper elevator accommodation in a given locality would be a help to the farmers of the locality, and the farmer argued that if an elevator was a necessary adjunct to the prosperity of the place, he ought to have a part in the ownership. Several of these elevators have lately passed into the control of private parties, an indication, presumably, that the farmer-stockholder and elevator-director has not found his management the most profitable. This centralizing of the management of the affairs of the farmer, domestic, business, and general, in his own hands, as reflected in institutions like the Patrons of Industry and the Granger movement, may be carried sometimes too far. An oligarchy, even of so reputable a section of the community as farmers, would not be desirable.

A STUDY of the monthly bank statements do not encourage an optimistic view of the trade situation. On the 30th of April last the total deposits of the banks were \$14,000,000 in excess of those of a previous year. On the 30th of September these had been reduced until they were below those of a year ago, while the loans and discounts of the banks had increased \$17,000,000. It would seem folly to close our eyes to the fact that all conditions point to a serious depression for the next six months. Money is undoubtedly slow, and there is little ground for expecting that it will become materially active in the immediate future. A fair wheat crop has been harvested, and where it may be wanting in quantity it is levelled up in quality. But prices continue to keep abnormally low. There is no

need, however, for anyone to become unnecessarily blue over the situation. The conditions are common to almost all parts of the world, and in Canada we are better off than in many other lands.

THE only let-up the Milling World can see to the continued depression in the flour markets is a succession of poor crops for several years. Our cotemporary thinks this will come. The prayers of the pulpit and closet as each seed-time returns is for a bountiful harvest. "May the rains fall, and the sun shine, and the earth bring forth of her fruit abundantly" are the breathings of the devout heart. We have been getting a surfeit of these good things, and the depression has increased as the harvests become more abundant. We do not say these things with any thought of irreverence, nor is there need for such to be implied. It is a phenomenon of political economy that is interesting to study. Abundant crops do not always bring riches. We may have so much of a good thing that the good thing loses its value. Yet, while there has been a surfeit of wheat, a supply at least beyond the ability of dealers to buy, and thousands of bushels of grain have been allowed to rot, peoples by the tens of thousands are crying out for bread to keep body and soul together, and no bread comes. We leave our readers to pursue further the thoughts that such facts naturally suggest. To employ a simple and commonplace colloquialism, "It's a funny world."

IT has been proclaimed with a good deal of vehemence lately that the growing speculation in grain has proven the ruin of the market. We reach a period now when speculation has become an unimportant factor of change, and prices of wheat were perhaps never lower. One writer places these two conditions in the relation of cause and effect. "The prevailing low prices of wheat," he avers, "is the dullness of speculation throughout the world. Speculation in wheat has not been at such a low ebb in many years as at present. Even among producers, the disposition is to sell, and the result is that out of a crop supposed to be the smallest on record, in proportion to population, farmers are selling such extraordinary quantities that the country can export at an unprecedented rate and still witness wheat accumulating weekly at the principal market centers. One result of these conditions will be that all the available surplus of wheat in the country will be shipped out in the first half of the year, leaving little to be done by grain merchants in the last half. Another result probably will be that the extraordinary low prices now prevailing will be followed next spring by prices unduly high."

A WELL-ARGUED plea for the small custom mill is made by a writer in the Mechanical News. The trend in mill building of late years is in the direction of larger mills—mills in fact on quite a palatial scale. This means, in the opinion of this writer, a centralizing of interests in a few large concerns, to the sacrifice of the smaller communities. The small mill, or as it is somewhat fitly termed, the missionary mill, is a pioneer in the opening of every new community, and the planting of a mill of the kind is going to add to the commercial worth of these communities. "Small mills," we are told, "have the commercial advantage that they enable more business to be done with a given amount of circulating medium, than where all the product of the district is sent away and there is imported or manufactured material from elsewhere. They serve to make the farmer, the miller, and everyone else in the district, partners and kindred. They help to make the neighborhood self-supporting and independent of freight rates; for that district which must buy its own flour, lumber and other things from outside, and must bring it over one freight-route is to a certain extent under the thumb of the owners of the route."

"Do not let anything connected with the boiler in your charge run from bad to worse," wisely remarks the American Miller, "with the idea that at some certain time you will have a general overhauling and repairing, because an accident may occur at any moment, involving serious loss of life and property."

**VIEWS AND INTERVIEWS.**

**Wheat Bread.**

The conclusion that wheat bread is unfit for dyspeptics, sometimes jumped at because ill effects are noticed to follow its use, is erroneous, says Food. On the contrary, it has been pointed out by Bouchard and others, that farinaceous food is peculiarly adapted to some dyspeptic patients. It is the microbes in the starch which is capable of producing irritating acids, that cause the trouble. To avoid this, Bouchard recommends that only the crust or toasted crumbs of the bread be used by dyspeptics, particularly those whose stomachs are dilated. The reason of this is explained by the fact that baking temporarily, though not permanently, arrests the fermentation of dough. When it is again heated by the warmth of the stomach the fermentation is renewed. In cases where the bread is toasted brown through, the fermentation is stopped permanently.

**About Cornet.**

Writing on the subject of boiler practice, one contributor to the Boston Journal of Commerce says: It is a common saying among engineers that the boiler-maker who condemns a boiler never gets the order for a new one. They seem to have a grudge against him, although he is not to blame in passing his honest judgment. We do not know how far this is true, but we do not think any intelligent owner would act in that way. There is an instinctive feeling, no doubt, that the boiler-maker may have condemned to sell a new boiler, but this is very seldom true, for we are inclined to think that the makers allow the mill to assume too much risk rather than condemn a boiler outright. A boiler-maker will keep a boiler running long after the insurance companies, with their constant supervision, have considered it dangerous to run. We think that, if a mill manager expects a boiler-maker to keep him warned against all probability of danger, he will not do so, but will be inclined to run many risks before actually condemning a boiler.

**What is Electricity?**

The rapid advances that have been made during the past ten years, both in the practical application of electricity to the service of mankind in the knowledge of the principles of the science, have brought us in the opinion of S. F. Walker (in the London Electrical Engineer) to the point at which we are obliged to ask ourselves, What is electricity? If the advance is still to continue? Up till very recently, notwithstanding the wonderful guesses that have been made by those not actually engaged either in the study or the practice of electricity, and the closer and closer approximations that have been made by those mathematicians who have given attention to the subject, it may fairly be said that we knew absolutely nothing as to what the mighty force we dealt with was. And, in addition to this, it has not been necessary that we should know what electricity was, so long as we were thoroughly cognizant of what it could be made to do. As far as the writer is able to understand the matter now, electricity is simply motion of the molecules of the different systems which are the subjects of electrical action, just as heat, light and sound are, and the only difference between these forces is the rate of the motion. The motion of sound, as we all know, is comparatively slow: that of heat and light very rapid. That of electricity would appear to be somewhat between the slow motion of sound and the rapid motion of the heat waves, whose motion is slowest. And it would appear that the wonderful adaptability which electricity shows for every kind of work is due entirely to the position which its rate of motion occupies in the scale of the energies. It would also appear that the reason this wonderful agent lay dormant for so many ages, and is even now only partially developed, is very largely, at any rate, because we have no sense which responds to the particular periods of vibration comprised within the electrical range. The writer will conclude this brief notice by remarking that heat currents would be far more efficient than electric currents if we could make use of them as we do the latter, and that, as he before remarked, the reason

electricity is such a useful agent appears to be because its rate of vibration is sufficiently high to admit of rapid transmission, yet not sufficiently so to be destructive. It only becomes destructive when it is transformed into heat.

**THE QUESTION OF "AGE" IN FLOUR.**

IN the October MILLER we presented a paper by Mr. W. T. Bates from the London, Eng., Miller, on the subject of age in grain and flour. Below we give another English view of that question, from the same journal, written by one signing "Ceres." He says. It was with great pleasure I saw the scientific question, "Does wheat become stronger with age?" dealt with in your last issue in the form of an article signed by that able scribe, Mr. W. T. Bates, but it was with great disappointment that I found, when reading Mr. Bates' article dealing with the question and considering the basis on which he relied in arriving at his conclusions, that I was totally opposed to them. Further, on dissecting his article, I was astonished to find that the foundations, in my opinion, on which Mr. Bates has built up his reasonings were done away with by the very conclusions his pen had arrived at. In one part of Mr. Bates' article I read the following passage:

"When the sickle severs the ear of grain from the root, we may, I think, say that the life of the plant is at an end, and that no further development can take place. There is, undoubtedly, a further hardening and fixing of the various constituents of the berry in some cases, but it is impossible that any new properties can be formed, and yet we all believe that wheat becomes stronger after it is practically dead."

While a little later the following passage occurs:

"It can not be contended that frost or wind has produced more gluten in the wheat; no, those agencies have improved it only by driving out the superabundant moisture. The bulk of grain will be somewhat reduced, it is true, by this drying-out process, and the gluten slightly increased relatively, but this will not account for the whole of the improvement. The true explanation, I think, is that the drying process has hardened the gluten and thus improved the whole mass, or in other words, by the drying out of the moisture the weak soluble gluten has been converted into strong insoluble gluten."

Now which of these two passages will Mr. Bates rely on? For there must either be a development by age in the gluten, or it must remain in the same condition as when the wheat was cut. My experience teaches me that the life of the wheat plant is not at an end when the sickle severs the ear of grain from the root, for any one with the microscope, with a fairly high power, can observe the gradual growth and closing of two valves, with their multitudinous number of hair fibres, over the cord by which the nourishment from the air and earth was conveyed into the berry, after it has been severed from the straw by the threshing process. The reason of this is, as every one knows, a provision that a kind Providence has made to prevent the moisture penetrating into the berry at this point when the grain is sown. If this were not so, the germ could not obtain any nourishment from its parent when it starts into life. Now, as to the development of the gluten I am unable to agree with Mr. Bates when he says:

"I give it as my confirmed opinion that, for the greater part, there is little or no difference in the strength of new and old wheat harvested under a blazing sun. When ripe, under such conditions it is just as fully developed, and all its qualities as firmly fixed as they ever can be, for the reason that all the moisture, which alone can do mischief, is dried out of it."

It must always be borne in mind that in the growth of the wheat berry there are three things that are developed for the purpose of nourishing the germ when it has arrived at the "period of "feeding on its mother," the formation of starch, then gluten and lastly, cerealine, which is the agent for dissolving the endosperm and so feeding the germ when it is sown and first starts growing. We know that a farmer must choose the time of cutting wheat, or he may lose not only the weight of produce per acre and the specific gravity or weight per bushel, but also the relative proportion of flour, bran and albuminous matters obtained. The reason for this

is that, after the gluten has become developed, the stage for producing the "destructive element" sets in, and that is why the farmers cut wheat before it is ripe, in order that the "destructive element," cerealine, may not increase too fast and so diminish the strength of the berry itself. Thus, from three equal plots taken from the same field of wheat upon thin limestone soil at North Deighton, in Yorkshire, cut respectively 20 days before the crop was ripe, fully 20 days before ripeness, and when fully ripe, Professor Johnston found the following composition:

When cut	In the Flour. Moisture per cent.	Gluten per cent.
20 days before it was ripe	15.7	9
10 days before it was ripe	15.5	9.0
Fully ripe	15.0	9.6

I will not go further with Mr. Bates' answer to "Does wheat become stronger with age?" as I think he will come to a different conclusion if he considers the whole question and watches the development of a grain of wheat from the time it is sown in the ground, as seed, until the hidden life produces food which, although it may be ground into flour, is not dead, but still developing; but I would like to quote one more passage from among Mr. Bates' extraordinary assertions. He says:

"The commonly accepted idea of strong wheat is wheat containing a large proportion of gluten, the characteristics of which are the ability to make a strong, tough, tenacious dough, and a good high loaf. Dough which can be stretched to a great length shows tenacity and an undoubtedly large percentage of gluten, and as such is strong, and if gluten is strength, surely this large quantity should make ideal bread; but, although gluten is the source of strength, in the sense that it retains the fermentative gases in the rising dough, yet to speak of it as strength is to express on'y half a truth, as in reality it may be a source of weakness under certain conditions. However, it is quite true that without gluten we can have no strength, so therefore gluten must be the basis of all strong wheat."

This statement I can not let pass without a contradiction as to what is strength in flour. For a wheat may have a large proportion of gluten and yet be a weak wheat; the percentage of gluten in flour may, by the "washing-out" process, be very high, and yet not make a lofty loaf of bread, and never can quantity of gluten be a source of weakness. If we examine carefully how starch, gluten and cerealine are produced from protoplasm by the action of sunlight, the decomposition of carbon-dioxide, and the assistance of nitric acid and water, we find that gluten is made strong by the welding together of its tissues. Therefore, strong wheat is that which contains gluten, and not a large quantity, with strong tissues. The amount of gluten with these well-developed tissues is another question for the consideration of bread-making, as it then is the difference between a lofty loaf and the yield of bread from a given quantity of flour.

**ATTENTION TO LOOSE PULLEYS.**

IT would seem unnecessary to speak of the great need of attention to loose pulleys and other "overhead work" in shops, as everyone must know of the importance of those things, yet they are shamefully neglected, as an incident of the other day testified to me. A countershaft was squeaking and grinding over a lathe that is never oiled (as none of the tools are until they refuse to go), and finally the shaft actually twisted in two, and had not the loose pulleys caught with the cone in such a way as to wedge and prevent their fall, a serious accident might have occurred, as men were working below at the time, but fortunately such was the case, and unfortunately the same thing will be repeated with the new countershaft when it is made, as a lesson is never taken until some one is badly hurt.

**TO PREVENT RUST IN TOOLS.**

A good preparation for preventing tools from rusting is made by the slow melting together of six or eight parts of lard to one of resin, stirring till cool. This remains semi-fluid, ready for use, the resin preventing rancidity and supplying an air-tight film. Rubbed on a bright surface ever so thinly it protects and preserves the polish effectually, and it can be wiped off nearly clean, if ever desired, as from a knife blade; or it may be thinned with coal oil or benzine.



The particular purpose of this department is to create an increased market for Canadian mill products—flour, oatmeal, cornmeal, rolled oats, pot barley, horse meal, split peas, etc.—at home and abroad. The interests of the miller who grinds the grain will have thoughtful consideration. Any matter that is likely to lead to an improvement of conditions in the local market of any of the various provinces of the Dominion will be carefully considered in this department. A close study will be made of the foreign markets with the aim of further developing the Canadian export trade. The Mill List each month covers very effectively the field of flour handlers and buyers of mill products, not only within the borders of the Dominion, but also in New Zealand, the West Indies, Great Britain and other European centres. This department will be made valuable to them in consideration of the conditions of the market in this country, reliable market data, the manufacture of mill products, methods of transportation and shipping intelligence in its bearings and relationships to the milling industries. We invite correspondence from millers, shippers and buyers on any matter involving these important questions.

#### THE RUSSIAN AS A MILLER.

AN important volume under the title of the "Industries of Russia" has been translated into English by Mr. J. M. Crawford, American Consul-General at St. Petersburg. We have been so accustomed to look upon Russia as the home of the oppressed, where stagnation is supposed to be the characteristic of the country, rather than enterprise and progress, that it is refreshing to learn from Mr. Crawford something of the business activity of this great country. His work is voluminous, covering five handsome volumes, and within the compass of these one will obtain full information as to cotton goods, flax, hemp and jute goods, woollens, silks, the paper industry, leather, the India-rubber trade, wood-working industry, machines and implements, glassware, ceramics, chemicals, matches, naphtha, cement, climate, soil, rural population and landed property, systems of agriculture, cultivation of the soil, breadstuffs, grain trade, flax and hemp products, gardening and viticulture, live stock and the cattle trade, rural economy, farming machines, agricultural school, industrial rural credit, forestry, household industry, fish, rural industries of the Caucasus, rural industries of Turkestan, mines and metallurgy, and an exhaustive article on Siberia's resources and her great railway, now being constructed. The impression that there is little of a commercial and manufacturing nature to enlist interest within the realm of the Czar is quickly abused in a study of these volumes.

Not the least of the growing industries is flour milling. Russia is so far away to the people of this western continent that we are not likely to think of it as a possible factor in business competition. In some branches of trade this may be so, but in flour-milling more and more it is becoming necessary for the miller to seek an outlet for his product in export fields. The population of Canada cannot readily consume a quantity of flour equal to the capacity of its mills. It must go elsewhere if these mills are to be fully employed. In a larger degree, doubtless, with her immense milling plants, is this true of the United States. So that in America we rest the success of our milling trade on the consumption and requirements of other countries. As the market has held for two years back it is hard to say what might become of flour, if a new competitor, of any size, was to step into the field. Is this competition likely in the near future? The Northwestern Miller makes the comment that: "We know Russia as a tremendous wheat grower, and the Russian as a miller is competent under proper encouragement to make flour as well and economically as an American. One might imagine a condition in the future whereby Russia would become not only a serious rival as a wheat seller, but a more serious one as an exporter of flour."

Mr. Crawford has this to say on the subject: "On the whole, it may be said that the number of mills in Russia is larger than is necessary for home needs. The mills bearing the manufacturing character are constructed according to the latest demands of technique, and are capable of producing flour of the highest grade, and much better than that required by the bulk of the Russian population. In recent years, with the development of these perfected mills, difficulties arise with regard to

the sale of especially the high grades of flour. Therefore, many of the mills have had to change the character of their product, namely, to work, in more considerable quantities, the medium and lower grades than would seem to be necessary, according to the perfect construction of the mills and the high quality of the grain at the disposal of the millers. The sale of these lower grades is considerably more warranted in Russia, as compared to the higher sorts, not so much because of the price as owing to the modest demands of the bulk of the population, which pays less attention to the aspect of the bread—that is, its whiteness—than to its nourishing qualities. Hence, it would seem that, owing to these conditions, nothing would be easier to Russia than to ship abroad the highest grades of flour finding no ready sale in the interior markets, namely, to England, Belgium and Holland, countries where no duties are placed on grain in general and no special duties on flour. However, it appears that precisely these same countries also consume flour of higher grades in considerable quantities, namely, for some special sorts of bread, and use chiefly the second and the lower sorts of flour for the baking of bread. Thus, in England, for instance, as a sample of flour used for the bread consumed both by the rich and poor classes, the so-called household bread, may serve the Russian perchaw (blue and red mark) that is, flour of second and third grades, or else the same sorts, the sale of which is quite warranted in Russia, and at such good prices as would not be received abroad if they exported. From Russia, flour is sent abroad in very inconsiderable quantities, namely, about 2,500,000 poods yearly. The export falls mostly to the south, and Odessa and Sebastopol are the chief points of shipment. The markets for it are European and Asiatic Turkey, Egypt and Great Britain. Turkey consumes the medium and lower grades of flour, and the other two countries, mainly, the higher qualities. The shipment of flour to Italy, France and Spain bears a casual character. The greatest activity with regard to the export of flour is shown by the mill of Veinstein in Odessa, which began the exporting business as early as 1863 and has a reputation so firmly established that its brands are bought in England according to the mark only, their quality being not inferior to that of the Hungarian flours, nor their prices as high. About 60 per cent. of the total export of Odessa falls to that mill."

#### CURRENT MENTION.

MILLERS who are doing a trade with Quebec and the Lower Provinces are interested in the announcement that rates on flour and grain for these points were increased on 13th inst. to last winter rates, which is an advance of about 5 cents per bbl.

The millers of Canada have good reason to feel gratified at the success of their exhibits at the World's Fair, Chicago. If we except Minnesota, which is the great flour State of the United States, a larger number of millers in Canada have carried off prizes and awards than in any individual State in the American Union. A list of Canadian prize winners is given in our news columns.

The old chestnut that millers are to blame for the reduced price of wheat was the statement submitted by E. W. Richards, of Tilbury, before the Dominion Government Comptrollers at a meeting of farmers in Kent county a few days ago. So few farmers themselves believe this nonsense that it was noticeable that beyond the bare statement of Mr. Richards the matter was not followed up either by the Comptrollers or by others who were consulting with the Dominion officers. There is not a tittle of evidence to show that Canadian millers have combined to keep down wheat prices. On the contrary, the discussions of the Dominion Millers' Association go to show that there is a constant effort being put forth to advance the interests of the farmers, and that whatever prejudice may have existed between farmers and millers in the past, the wise policy to-day is for these two sections of the community to pull together: and they do pull together.

There is seldom an excuse for a dirty or untidy place of business even where the business itself may not, per-

chance, be of the most cleanly nature. Certainly no store, manufacture or mill that makes up or sells that which is to constitute food for men, women and children, should be other than cleanly and inviting in all its appointments. This is the thought which the Canadian Grocer would impress upon those of its readers who handle flour or feed. It counsels a tasty window display. Samples of cereals and flour put up in glass jars look well, if kept clean and frequently renewed. "Neatness is one of the sure roads to success, as a housekeeper will prefer buying at a well-arranged and tidy store than from an ill-arranged and untidy one." Keep the flour stock away from the corner of the store where oils are stored. Paper sacks should be changed often as they become faded and soiled by exposure to the sun. And all important, only keep for sale brands of flour of known good quality that can be safely recommended to customers.

#### THE FLOUR MARKETS.

LITTLE of interest can be written of the flour markets. Depression continues. Sales are comparatively light and prices unsatisfactory. There is no encouragement to push export trade, foreign markets remaining dull and over-stocked. Oatmeal is in good demand, and so of rolled oats. The Northwestern Miller, of current date, says of Minneapolis markets: "The mills rolled up another big output last week, making 234,375 bbls.—averaging 39,602 bbls. daily—against 229,740 bbls. the week before and 215,090 bbls. for the corresponding time in 1892. Of the 22 mills in motion a week ago two have dropped out of the list on account of breakdowns. The output this week will therefore show something of a decrease. Everybody is possessed of a desire to get flour as fast as possible before the close of navigation, and it is only physical conditions that prevent the quantity ground from touching much higher figures. The weather could not be more perfect and the water power is ample for the heavy work being done. Millers are daily looking for a change to a lower temperature and the resultant stopping of lake navigation. The flour market has been exceptionally flat for a week back, the weakness in wheat confirming buyers in their bearish opinions and confining the transactions to the smallest limits. For the week ended Saturday the orders booked for flour probably did not amount to 100,000 barrels. The mills, of course, are working to a considerable extent on old orders. The export trade is about as light as it well could be, the bids of foreigners ordinarily being 15 or over below what flour can be sold at without actual loss. This makes it rather difficult for millers to dispose of their bakers' as fast as it is made. The domestic price of patent is a shade lower than it was a week ago. There is a very good demand for low in this country as feed, most of it being disposed of in this way. The direct export shipments by the mills last week were 48,485 bbls., against 67,910 bbls. the preceding week."

#### PRICES OF FLOUR AND MEALS.

Toronto: Flour (Toronto freights) Manitoba patents, \$3.80 to \$3.90; Manitoba strong bakers', \$3.60 to \$3.70; Ontario patents, \$3.10 to \$3.20; straight roller, \$2.80 to \$2.90; extra, 2.50 to 2.75; low grades, per bag, 90c. to \$1.10. Bran—\$12. Shorts—\$14 to \$14.50. The Flour and Grain Trade Bulletin of the Dominion Millers' Association says: Straight grades at \$2.75 to \$2.90 west; and \$1.20 per 98lb. in buyers' bags, and 90 per cent. patents at \$2.90 to \$3.00; and 85 per cent. patents at \$3.15 f. o. b. for Lower Provinces. Bran, \$11.50 and \$12.00. Shorts, \$14.00.

Montreal: Manitoba patents, best brands, \$3.70 to \$3.80; straight rollers, \$3.10 to \$3.15; extra, \$2.90 to \$3.00; superfine, \$2.60 to \$2.90; Manitoba strong bakers', \$3.40 to \$3.60; best brands, \$3.60 to \$3.70. Oatmeal, Standard, per bag, \$1.90 to \$2; do. per bbl. \$3.80 to \$4.10; granulated, per bag, \$2 to \$2.05; do. per bbl. \$4.20 to \$4.30; rolled oats, per bag, \$2.05 to \$2.10; do. per bbl. \$4.25 to \$4.35. Bran, \$15 to \$16; shorts, \$16 to \$19; moullie, \$22.

Winnipeg, Man.: Quotations in small lots to the local trade are: Patents, \$1.70; strong bakers', \$1.55; XXXX, 80 to 90c. Oatmeal, \$2.70; cornmeal, \$1.75; buckwheat flour, \$4; rye, \$3. Beans are quoted at \$1.80 to \$1.90 per bushel; split peas, \$2.40 to \$2.50; pot barley, \$2.40 to \$2.50; and pearl barley, \$4 per sack.



Office of the CANADIAN MILLER, }  
November 15, 1893.

**THE GENERAL SURVEY.**

**WHAT** is to be the outcome of wheat prices? is the problem with which grain experts of this continent and the older world are just now wrestling. Everyone has talked of wheat having reached bottom; has it? December wheat is on record as having touched the lowest point ever touched for that month. Stocks of wheat on hand almost everywhere are abnormally large, and in the United Kingdom are much in excess of what is usual at this time of the year. Russia is showing her hand as an active competitor and is placing wheat in London and Liverpool at a price that renders export, in competition from America out of the question. India is a factor that has to be considered, and as we pointed out in these columns last month, so is the Argentine Republic. Both these countries are now selling freely.

Mr. Broomhall, editor of the Liverpool Commercial Trade News, believes that wheat is cheaper at current values than it should be, taking the general position of the cereal into account. This condition he makes chargeable upon the American farmer, who rushed his wheat to the market the early part of the season before the market had recovered from the heavy stocks of the previous year. On top of this came an unexpected accession of 16,000,000 bushels from South America. The conclusion of the whole matter in Mr. Broomhall's view is in these words: "Not for much longer will the seller be calling to the importer to buy. For two years supply has largely overtopped demand, but now the requirements are quite certain to fully equal the present and prospective supplies." Next year the wheat area, he thinks, will be further reduced, and in this way conditions will be levelled up, and the outlook will become more encouraging for wheat producers.

The Minneapolis Market Record of Nov. 7 says: "The cause for the present weakness in wheat is easy to locate, and is due, principally, to the large and increasing supplies. The visible supply of this country last week increased 2,069,000 bush. This makes the present total 71,306,000 bush. The amount held in Europe is largely beyond immediate requirements, and the amount abroad for Europe showed an increase for the week of 782,000 bush. The demand in this country for export is very small, and, as this is largely an exporting country, the effect, of course, is severely felt. That gives us weak markets. Europe is overstocked, and Russia is offering liberally. That wheat, with what other countries are sending, is more than is required, when the home supplies are so large as now. This makes foreign markets weak. When, from any cause, a little strength is infused into the markets of this country, European markets show no sign of sympathy because of the large amount that is available to them at less than our present prices. India, while still handicapped in its shipping by the silver question, is shipping more freely now than for months, and, as is known, has a large surplus. Shipments from Russia will soon be shut off by the cold weather, but the Republic of Argentina has a quarter of its surplus left from the last crop. This amounts to some 9,000,000 bush. The present acreage for the new crop is reported in good condition, and will be ready to cut in about two months. Roumania is about as large an exporter as Argentina. Owing to the large supplies European buyers have little regard for the course of American markets, and appearances indicate that little help is to be expected from them until their stocks are reduced and the future prospects for obtaining more from other countries than this are not so favorable as now. Without their help our supplies will continue to increase, and the large supplies are what are bothering everybody and causing such weak markets."

Great difficulty is experienced in obtaining information of the actual yields of wheat in different countries. There have been some very bullish statements published, pointing to a wheat shortage of many millions. Against this comes such news as we have already chronicled from South America showing quantities of wheat to exist where they have not been expected. And worse than this is the growing practice of manufacturing crop news to suit the purposes of various speculators. Altogether it is a period for the grain men where the safest move is a slow move.

**CURRENT PRICES OF BREADSTUFFS.**

**WHEAT:** Toronto: White, 57c.; spring, 58c.; red winter, 56c.; goose, 56c.; spring, Midland, 59c.; No. 1 hard, 71c.; No. 2 hard, 69c.; No. 3 hard, 66c. The Grain Trade Bulletin of the Dominion Millers' Association quotes: Ontario fall wheat, very little offering. Holders asking 57c. to 58c. straight for fall, and 58c. to 60c. for spring. Montreal. No. 1 hard Manitoba wheat, 69 to 70c.; No. 2 hard Manitoba do., 67 to 68c. Chicago: November, 60 3/4c.; December, 61 3/4c.; May, 69c. St. Louis: For cash, 57c.; November, 57 1/2c.; December, 58 3/4c.; 66 1/4c. to 66 3/4c. asked for May. Duluth: No. 1 hard, 61 3/4c. for November; No. 1 Northern, 60 3/4c. for November; No. 1 hard, 61c. asked for December; No. 1 Northern, 60c. asked for December; No. 1 hard, 60 3/4c. for May; No. 1 Northern, 65 3/4c. bid for May.

**BARLEY:** Toronto: Obtainable at 40 to 41c. A Buffalo despatch of 13th inst. says of United States markets: There has been a considerable increase in visible supply of barley during the past week, stocks in principal accumulating points now amounting to 3,308,000 bushels against 2,816,000 bushels last week. The increase has been principally in Buffalo, where large lake cargoes being received have augmented the supply. There are now 809, 872 bushels in store here, or about 100,000 bushels more than at this time last year. There is a very large portion of this cheap grade barley fit only for feeding purposes. There is a good supply, however, of the better grades, but no very great demand. Millers pick up an occasional lot for immediate wants, but they are not taking up much, as they consider the prices too high. Sellers' quotations are: Western, No. 2, 60c.; No. 3 extra, 55 to 56c.; No. 3, 50c.; sample, 47 to 48c.; state, choice, 70 to 72c.; No. 2, 65 to 68c. At New York—in store to-day, 150,000 bush; market quiet; western sample, 55 to 56c.; No. 2 Milwaukee, to arrive, 62 to 63c. At Chicago—Stocks, 121,000 bush. a decrease of 100,000 bush. during the week; the market is dull; No. 2 nominally quotable at 55c. At Milwaukee—There has been a decrease of 100,000 bush. for the week, stocks now being but 263,776 bush; market quiet and quotations lower; No. 2 spot and November, 51c.; December, 52c. At St. Louis—Barley is beginning to accumulate, but the market is dull. At Minneapolis—Stocks are increasing slightly, there being now 205,404 bush in store there.

**OATS:** Toronto: Quiet; Mixed, 33c.; track; White oats, west, 29c. Chicago: November, 28c.; December, 28 1/2c.; May, 31 1/2c.

**PEAS:** Toronto: Dull; Sales westward, 52c.

**RYE:** Toronto: Little doing. Few sales at 43c.

**DOMINION MILLERS' ASSOCIATION.**

**R**EFERENCE was made in a recent CANADIAN MILLER to the fact that the Executive of the Millers' Association were giving consideration to a charge made by the Knickerbocker Company of Jackson, Mich., against various Ontario millers, for infringement of their patents on the Cyclone Dust Collector. A result of this consideration is the issuing of the following circular over the signature of A. H. Baird, President of the D. M. A.:

"The Knickerbocker Company of Jackson, Mich., who own the patents on the Cyclone Dust Collector, have, through their Solicitors, Messrs. Mabee & Gearing, Stratford, taken action for royalty and past damages for infringement against all parties who are using the Cyclone Dust Collector on which royalties have not been paid, claiming \$25 on each Cyclone Dust Collector used for Middlings Purifiers or Exhausts from Rolls; \$25 for each Cyclone Dust Collector used for Wheat

Cleaners; \$50 for each Cyclone Dust Collector used for other purposes, together with damages for the period the machine has been used in the past. By an arrangement with the Association made, through the Executive Committee, with the Knickerbocker Company, all members reporting at once to Messrs. Mabee & Gearing, Stratford, the number of Cyclones they have in use, the purposes for which they are used, and paying \$20 for each Cyclone Dust Collector in use on Middlings Purifiers or Exhausts from Rolls, \$30 for each Cyclone Dust Collector used for other purposes, will receive a license for the use of the Dust Collector during the remaining years of the life of the patent, and the claims for damages for past infringement will be waived on machines reported. This arrangement only extends to members of our Association, of whom Mabee & Gearing have been furnished with a full list.

"The Executive Committee would urge every member of the Association having Cyclone Dust Collectors not made by W. & J. G. Greey, or the North American Mill Building Co., who, we understand, manufacture under license from the Knickerbocker Company to at once carry out the above arrangement and prevent any action being entered against you and so incurring unnecessary costs, and also get the benefit of the reduction obtained by our exertions. Writs were already issued against some of our members, but further action has been stayed at our request, to give an opportunity to all our members to carry out the arrangements suggested above.

"I trust you will not delay in making a full report to Mabee & Gearing, Stratford."

**THINGS TO REMEMBER ABOUT SHAFTING.**

Don't buy light hangers and think that they will do well enough, when your own judgment tells you that they will spring.

Remember that shafting is turned one sixteenth inch smaller than the normal size.

Cold-rolled and hot-rolled shafting can be obtained the full size.

The sizes of shafting vary by quarter inches up to 3 1/2 inches. The ordinary run of shafting is not manufactured longer than from 18 to 20 feet.

For line shafts never use any that is smaller than 1 1/4 to inches in diameter, as the smallest diameters are not strong enough to withstand the strain of the belts without springing.

The economical speed of shafting for machine shops has been found to be from 125 to 150 revolutions per minute, and for wood-working shops from 200 to 300 revolutions.

A jackshaft is a shaft that is used to receive the entire power direct from the engine or other motor, which it delivers to the various main shafts.

Keep the shaftings well lined up at all times, and this will ward off a break down and avoid a waste of power.

Know that the pulleys are well balanced before they are put in position, as a pulley much out of balance is quite a sure method to throw shafting out of line.

Look at the pulleys and see that they have been lapped to the size of the shaft and prevent smooth running.

If possible, apply the power to a line of shafting at or near the centre of its length, as this will enable you to use the lightest possible weight of shafting.

Hangers with adjustable boxes will be found to be the most convenient for keeping the shafting in line.

Keep your drip-cups cleaned, and do not allow them to over flow or get home.

Have a supply of talcum in the boxes; in case of accidental heating it will melt and prevent cutting; this rule, while good for general use, applies particularly to special cases where there is a supposed liability to heating.

Never lay tools or other things on belts that are standing still, for they may be forgotten and cause a break-down when the machinery is started.

Don't attempt to run a shaft in a box that is too large or too small, as you will waste time and fail to secure good results.

A loose collar held by a set screw will cause the collar to stand askew, and it will cut and wear the box against which it runs.

In erecting a line of shafting, the largest sections should be placed at the point where the power is applied. The diameter can then be gradually decreased toward the extremities remote from this point.

Don't try to economize in first cost by having long distances between hanging, for a well-supported shaft will always do the best work; short shafts are surest to be straight and remain so. American Engineer.

## OLD-TIME GRIST MILLS.

It is hardly likely that there is anything in the following sketch that is very new to some engaged in the milling trades. Their memory will take them back to such experiences as are here described. But a younger generation is growing up who know nothing of the difficulties of their fathers in milling. The advantages of to-day will be better appreciated by a knowledge of the drawbacks of the past. Besides, as Artemus Ward has said, there is some pleasure and satisfaction in reminiscing occasionally. The sketch that follows is condensed from a paper that appeared in the New Haven Register.

"Three-quarters of a century ago," says the Register, "no neighborhood was considered to be completely equipped for the benefit of its inhabitants unless it possessed a grist mill, and if a farmer had to go more than three miles to get his grain ground into flour for his family, or the coarser cereals for the use of his swine, horses and cattle, it was thought that he was inconveniently located. In those times a brook from 3 to 10 feet in width was made to do duty wherever there was a fall of from 5 to 20 feet, by a dam being thrown across, forming a pond of from half an acre to one, six, or a dozen times as large. There would be located a grist mill generally with two runs or pairs of buhr millstones and sometimes three with which to reduce the grain grown in the neighborhood to an edible form for man and beast. If the water power thus obtained was sufficient, there was generally hard by a long, low saw mill in which, especially in the spring of the year, when the stream was at its full, the logs cut from the timber land of the farmer were transformed into boards and plank with which to build and repair the buildings of the vicinage. Of these millstones one set was usually devoted to the grinding of wheat, rye, corn and buckwheat for family use and the other run was used to grind a mixture of corn and oats into provender to feed horses and also to fatten the swine for winter consumption.

"But as the country grew, mills run by water became numerous, as they were enabled to work with greater celerity and certainty than the mills run by the wind. The miller became a man of consequence in the neighborhood. His compensation was quite liberal, as custom, which in many instances makes common law, gave him what was called a toll of one-tenth or one-twelfth the grain for his compensation in turning it into flour. Thus if a farmer loaded up his ox cart with to bushels of rye to be made into flour for his family, the miller took one bushel of it and put it in his private bin. Indeed, some of the censorious inhabitants were wont to believe that sometimes the white-coated miller would dip his dish rather too deep into his customer's grain and many of them had a fashion for weighing the flour after it came back from the mill. Thus it was reckoned that one bushel of rye would produce 26 pounds of flour after the usual toll or wage was subtracted from the grist. And if the worthy customer happened to find that his steelyards reported but 22 or 23 pounds of flour to the bushel, the farmer simply had his opinion of that miller, and the latter was often mortified and annoyed to find that his whilom customer was patronizing a rival miller two or three miles up or down the stream as the case might be. But when it was found that the weights held out and the customer obtained what he considered his rights, then the character of the worthy miller was duly established, and he had the call of the custom far and near.

"In the old-fashioned 'Farmers' Almanack,' which always used to hang in the kitchens and sitting-rooms of our grandfathers and grandmothers, there might be found at the head of the page giving the month of January a picture of a boy skating on a mill-pond. The youth was dressed in the prevailing style of the year 1820, and his coat was almost a counterpart of the 'claw-hammer' or 'swallow tail' worn by gentlemen at dinner parties and Germans at present day. Along the road skirting the mill-pond was a piece of woods and a man in his shirt sleeves was depicted in the act of cutting down a large tree, evidently for firewood. Going along the road near by is a man driving a one-horse sled, loaded with cordwood. In the distance, at the foot of the three-acre pond, stands the inevitable grist

mill, with a large overshot wheel which is the motive power that grinds the grain. Close by is an old-fashioned house with a large chimney, and there is an appearance of comfort and good living about the picture that appeals forcibly to the memory of old people who in their youthful days can remember similar scenes. The inference to be drawn from the picture is that in those days people worked for a living and that they were perhaps more industrious than their degenerate grandchildren.

"In those days the miller was easily one of the most prominent and important men in town. The mill had a certain attraction for the small boys of the neighborhood. They were never weary observing the revolutions of the big, noisy water-wheel as the rumbling gearing attached which drove the millstones. When the flour came from between the upper and nether millstones it was carried in the little tin cups of the elevator to the large bolting box, where it went through very fine netting through which a fine horse-hair could scarcely pass. When it had come down into the receiving box and was sufficiently cooled to prevent it from souring when it came into the possession of the housewife, it was dipped into the customer's bags with a clean and bright tin scoop holding three or four quarts perhaps. It was often the habit of the customer if his grist was a small one and he had two or three miles to go to mill, to wait for his grain to be ground that he might take it back home with him. Then, perhaps, he would meet there two or three of his neighbors with similar intentions and this gave them an opportunity to talk and gossip over the affairs of the neighborhood and this made the mill a sort of rendezvous to hear and impart local news and the happenings of the time. Thus it was that many political views were exchanged and if that failed why there were points of religious doctrine and belief to be discussed. And so it became an almost certainty that the miller became a man of affairs and was placed in the position of a man whose opinions were deferred to and his views treated with great respect. Perhaps there was not as much scandal afloat there as there would be in the country shoemaker's, which was another necessary not to say indispensable institution. But after all, if the miller could not tell all the news in circulation it was argued that he was either very deaf, that he had been sick for weeks or else that he had been away from home for some time past.

"The mill, as a usual thing, was generally a two-story building about 30 feet by 24. The upper story was used to store customer's grain in, and by an ingenious device it went into the lower story and into the hopper by force of gravity. The hopper was about the shape of one of the Egyptian pyramids turned upside down. It would hold three or four bushels of grain, which slowly filtered through a small orifice down into the hole in the upper millstone, where it was quickly caught by the sharp grooves in the lower stone and instantly crushed into flour; then it went through the elevator into the bolt box; then the bran was separated from the flour by the fine bolting cloth previously mentioned. This bran was used to feed the cattle, sheep and hogs of the customers. And, by the way, there is a saying, fully a century old, to the effect that 'a miller has always fat hogs and that everybody knows it,' and then the cynical and distrustful conclusion of the saying was that everybody did not know on whose grain said hogs were fed. The elevator was a leather belt about 30 feet in length running along a long wooden box about four inches across. About 15 inches apart were triangular-shaped tin cups, each holding about half a pint. But in each cup the amount was usually about a tablespoonful. The belt ran through the long box at an angle of 15 degrees from the perpendicular and the flour cooled quite rapidly while on its way to the bolting process.

"In the location of the mill it was usually made a point to place it where teams from the highway could reach it handily. If it were placed at the foot of the falls it would necessitate a very steep road and heavy draught on the part of the customer's teams. Therefore the mill would usually be located on the bank a short distance from the stream and the water to carry it would be conveyed in a 12-inch trunk from the bulkhead to the overshot wheel, if the fall was 10 feet or

more. The wheel was usually outside the mill, and to carry two run of stone was generally about 10 feet in diameter with buckets from four to five feet in length or thereabouts. If they were say three run of stone the wheel was larger proportionally. If the head of water was less than 10 feet then it was in order to have a breast wheel constructed. The difference between these wheels consisted in the fact that the water ran on the top of the overshot wheel and in the other it met the buckets about half the way down on the backside of the wheel. An overshot wheel was much more powerful than a breast wheel and in fact it would do the same amount of work that the breast wheel did with barely half the water or motive power. Where there was a large amount of water and a very little fall then an undershot wheel was used. The water ran underneath the wheel, and its running force against the paddles set it in motion. It would require four or five times the amount of water to run an undershot wheel that it would an overshot wheel, and twice as much as to run a breast wheel. To shortly describe the difference between the wheels it may be said that the overshot wheel is propelled purely by the weight of water in the buckets, the breast wheel is carried partly by the impulse of the water and the undershot almost entirely by the impulse of the water against the floats or paddles.

"In the fall of the year the miller was always expected to be very punctual in promising his grists for his customers. There were occasions when it was a treat for the farmer's family to receive from the mill the grist of buckwheat flour, which was the staple winter food for them. Very few of the farmers would forego the pleasure of eating buckwheat cakes, which, when sweetened with honey made by the busy little bees during the season when the buckwheat field is in a snowy state of blossom. It has been said by an observing individual that buckwheat is a very quick grain in all respects. It is sown in the month of June in the farmer's busiest and most hurrying season. It matures quickly and is ready to be harvested in September; being much quicker for harvest than any other grain, it must be thrashed quickly from the field and cannot be stored away like oats, wheat or rye. It is ground very soon after being gathered; it is ground very rapidly in the mill; it must be baked in the griddle in double-quick time, and last of all, it must be eaten quickly after baking and while smoking hot, for if ever there was an article of diet that is unpalatable it is a cold buckwheat cake. Even a fastidious hog has been known to turn up his nose at one that he found in his swill, and to root it out of the trough and trample it on the not over clean floor of his pen. But when the buckwheat was thrashed, then the good housewife at once insisted that a few bushels must be taken to the mill to be ground as soon as possible, and when it came home and the batter was mixed and ready for the breakfast's baking, it would take one person to bake over a quick fire in order to keep six of the rest of the family eating.

"The old-fashioned grist mills with their buhr millstones, are rapidly getting to be things of the past. Those that remain are used for grinding feed for the small number of animals that the farmer of to-day keeps. It does not pay him to raise beef, for the refrigerator cars bring beeves by the thousand carcasses from the far west in from two to three days, that have been fattened on the vast prairies of the west.

"The old-fashioned miller did not consider himself thoroughly skilled in his trade until he could pick the hard millstones properly. This was done by means of a sharp steel pick fastened on a handle the same as a hammer is fastened. When he was engaged in 'dressing' the stones, which was necessary to be done once in the month, he had to put on a pair of huge spectacles with lenses two or three inches in diameter so as to keep the flinty particles out of his eyes. Should one of these get into the eye it would be vastly worse than a fine cinder from a coal-burning locomotive."

O, WHAT has become of the "big-yielder" bold, who pushes the yield, with his jaw uncontrolled, down, away down to a degree all untold? Has he crawled in his hole since the last time he squealed, and pulled the hole in on a 3:30 yield?

# COOPERAGE D'P'T.

There is a close affinity between the work of the cooper and the business of milling. The miller is either his own cooper, having a cooperage as an adjunct to his mill, or else he resorts for his supplies on an outside cooperage. The cooper in any case finds one of his best customers in the miller. The object of this department is to bring each in close touch with the other and to materially advance the interests of both trades.

### TRADE REVIEW.

We regret to say that we have no very bright news to report this month, as trade all over Canada remains very quiet. The millers are not using any large quantities of barrels, and the salt and other industries are also very quiet. We only know of very few millers who are barreling the bulk of their output, the rest of the millers using bags and sacks.

Mr. N. H. Stevens, Chatham, owing to his using the colored and grooved hoop, has had a great run, as this barrel is taking exceptionally well in the Eastern Provinces, and also answers for the West India trade. Taylor's mill, Chatham, are now also using the colored and grooved hoop, and a great many other millers are enquiring for this hoop.

There has been a radical change this year in the way that barrels are being made. Formerly all the millers in Canada used to use air-dried stock, but progressive millers are now all using kiln-dried staves and heading for their barrels and demanding hoops of the very finest quality; the consequence is that claims for re-coopering barrels do not come thick with the frequency that they used to at their destinations. Although they cost the miller a little more at first, still in the end he saves money and also a great deal of annoyance as well.

The sugar refineries are running light, so that they are not consuming the quantity of stock they usually do at this time of year. It is now about the time that prices of cooperage stock advance for the winter months, but up to the present the advance has not been put in force, or do we think it will come in before the 1st of December at the latest. Cooperage stock is just the same price now that it has been for some time.

The cornmeal and oatmeal mills are running a little stronger than they have been doing, still they are not running to their full capacity; however, as the weather gets colder these mills will increase their output, which will tend to stiffen prices of cooperage stock. For carload lots of cooperage stock the following are the present prices delivered in Toronto:

	Per net 1,000
No. 1 28 1/2 and 30" pointed elm staves	\$5 85
M. R. 28 1/2 and 30" "	5 50
No. 2 28 1/2 and 30" "	3 85
" 1 24" pointed elm staves	4 65
No. 1 5 1/2 ft. patent coated hoops	6 05
" 1 6 ft. "	6 65
	Per set
No. 1 17 1/2" kiln-dried heading	4 1/2 c.
M. R. 19" "	5c.
No. 2 17 1/2" "	3 1/2 c.
" 1 14" "	4c.

For kiln-dried staves the price is 25c. per 1,000 more than the above figures, and for the colored and grooved hoop the price is also 25c. per 1,000 more than the ordinary patent coated hoop, the extra cost being for the coloring of the hoop which is done with the extract of logwood.

### UNITED STATES MARKETS.

The Northwestern Miller says of the Minneapolis market: "Though there was a small decrease in the number of barrels taken by the mills last week, the figures were far from small. Nearly every shop got a fair proportion of the business. Almost one quarter of the sales consisted of magwump barrels. The make of barrels was heavy, and even after deducting for packages shipped to outside points, several thousand were left over the sales. Notwithstanding this, one shop has added more men to its force, while another, though employing half a dozen extra coopers, has been drawing from its storehouse. Other shops, of course, are accumulating some barrels. About 1,500 half barrels were sold last week. The mills appear to be taking barrels with fair freedom this week, and with the flour output increased somewhat, the sales are likely to be larger."

Of Chicago, the Lumberman says: "The tone of the cooperage market is materially better this week, and prices on tierces and punk barrels have advanced to \$1 and 90 cents, respectively. Receipts of bugs are heavier than they were a week ago, and packers are disposed to buy more freely in consequence. Demand for hoops is not so urgent because of increased receipts, and prices are weaker. Hoops have been selling at \$12 to \$13, but it is likely that anything over \$12 will hereafter be considered a good sale. Heading is coming in a trifle too freely to supply the wants of coopers, but so far there has been no trouble in disposing of all arrivals. Punk staves are not plenty, and are selling at \$16 to \$17. Tierce staves are arriving in fair quantities, and small lots known to exist have shown up at prices advanced. Sales are being made at \$21 and \$22, with a fair demand for good stock.

There is no activity in flour barrel stock.

### COOPERS' CHIPS.

Mr. THOMPSON, of Chatham, is putting in one of the Vale barrel machines, which turns out barrels at the rate of 40 to 50 per hour, depending on the speed of the operator, such being winlassed, crozed, chamfered, equalized, and having on two permanent end hoops. This machine is adjustable, and any size of barrel can be made upon it from 24 to 34 inches in length and from 13 1/2 in. to 20 in. head. The principal points claimed for the machine are the way in which the staves are fed to the machine, almost in the same manner as paper is fed to a printing press. Of course, the machine has not been thoroughly tested in Canada as yet, but it has been given a fair trial in the United States, and is liked very much there. There is no reason that the machine should not be a success if kiln-dried staves are used, and after it gets into thorough working order in Chatham we can say more about it.

A new pattern of barrel is being used, by some of the Minneapolis mills, in which to ship out sample lots of flour. It was designed by E. Ford, an eastern man. Its novelty consists in that it is hooped partially with half-round wire, about three-sixteenths of an inch wide. Six of these wires are distributed over the body of the package, with a hickory hoop on each chime. The Acme Hbl. Co. is getting out the barrel, paying its men 6c. for hooping off. The hoops are furnished by Mr. Ford, already for use. It is thought that the coopers, after getting used to the work, can make the barrel for about 5c. Some of the millers who have sent out the package are favorably impressed with it.

### STEAM BOILER INSURANCE.

We take pleasure in directing the attention of the owners of boilers to the advertisement of a London Boiler Inspection and Insurance Company which appears on the third page of this issue. Judging from the large number of disastrous explosions which have taken place in Canada and the United States, it is about time that steam users were awakened to the fact that an insurance company with a heavy monetary interest in the boiler and premises will see that the boiler is in a safe condition, and that the man in charge of the engine is capable and trustworthy. It is better that the responsibility should be assumed by a company that has a staff of trained engineers, than by the owner of the boiler, who, except in a few cases, is not capable of judging of the condition of his steam plant. Within the last two weeks there were four explosions of steam boilers in Canada, all of which resulted fatally to those in charge of and in the immediate vicinity of the boilers, to say nothing about the loss through damage of the property. The subject of boiler inspection is receiving more consideration to-day than it has for a long time.

### LEADS THE WORLD.

THE Magnolia Metal Company, having offices at New York, Chicago, London and all over the world, has been allotted the highest award possible at the World's Fair, Chicago, on their Magnolia Metal. A medal has been granted and a diploma with following specifications allowed and set forth:

- 1--It prevents hot boxes.
- 2--It will not cut or heat journals.
- 3--Its lasting qualities are of the highest order.
- 4--It is a self-lubricating metal, saving large percentage of oil.
- 5--It increases the motive power.
- 6--It is the only metal that protects and does not wear journals. It enamels them.
- 7--It is adapted to high and low speed machinery.
- 8--It will stand the heavy work of sugar, rolling, saw and wire mills.
- 9--It is a success in main journal and crank-pin bearings; also, gibs of steamships and steam trigs.
- 10--It is the best water metal.

### FAIR WARNING.

In these days of few dust explosions, millers should not grow careless. The time for night work in all mills is now at hand, and more artificial lights should be used in a mill, and by keeping them out the risk of danger from this source is greatly reduced. The most destructive dust explosion that has occurred in Europe for many years occurred in a flour mill at Hesperingen, Luxembourg, recently. It was followed immediately by fire, and the plant was completely consumed. Several died from injuries received, and others were badly injured.

### PUBLICATIONS.

FROM out of the large number of trade journals, that reach this office, English, American and Canadian, we can easily give the special Fall number of the Canadian Grocer, published by the J. B. McLennan Publishing Co., of Toronto, a foremost place. The lithographed cover in handsome, whilst the letterpress and illustrations reflect great credit on printer and engraver. The contents are specially suited to the trades represented, and embrace a wide range of topics, telling of the painstaking care and ability of the editor.

# STEAM PUMPS

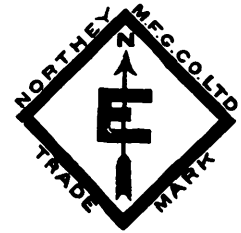

# Duplex AND SINGLE Steam AND POWER Pumps

If you require a pump for any duty, of the latest and most improved pattern, and at close prices,

## WRITE US



# NORTHHEY

## M'FG CO.

LIMITED

TORONTO - ONT.

**WANTED AND FOR SALE**

Advertisements will be inserted in this department at the rate of 15 cents per line each insertion. When four or more consecutive insertions are ordered a discount of 25 per cent will be allowed. This notice shows the width of the line and is set in No. 10 square type. Advertisements must be received not later than the 27th of each month to insure insertion in the following issue.

**MILLER WANTED**

WANTED, A GOOD MILLER TO MANAGE a 7-barrel mill. Must be competent man and single. Address

A. LAPOINTE,  
St. Justine de Newton, Que.

**SITUATION WANTED**

BY MILLER, 25 YEARS EXPERIENCE. Working single, industrious and strictly temperate. Uses no tobacco in any way. Best of references. State wages when writing. Good mill. Address

JNO FORD, Jr., Markdale, Ont.

**FOR SALE.**

A LIMITED QUANTITY OF HICKORY half round hoops, suitable for barrels for the West India trade. Inquire of

JOHN CAMPBELL,  
Eric Mills,  
St. Thomas, Ont.

**FOR SALE**

BUCK WHEAT FLOUR MACHINERY, ONLY run two years, reason for selling, want of room. Machinery can be seen running. Will take back wheat flour in payment. Apply to

JOHN MACKAY,  
Caledonian Mills,  
Bonnaville

**FOR SALE**

ONE DOUBLE SET, 93 1/2 in. ROLLS, (Greys make). One Double Set, 93 1/2 in. Rolls, (Goldie & McLaughlin make).

Two Inter-Elevator Flour Bolts 5 feet by 13 inch cylinder.  
Two Round Scalpers, 3 feet by 20 inch cylinder.  
One Purifier, No. 1 (Harter make).  
One Eureka Smit Machine, No. 1.  
One Cut Separator, No. 1.  
One 6 inch Water Wheel (Leffell), and a quantity of Shafts, Pulleys and Gears.

The above machinery is as good as new, and will be sold cheap, for cash. Apply

DOBSON & CAMPBELL,  
Beaverton, Ont.

**FOR SALE**

I OFFER A SEVENTY-FIVE BARREL ROLLER mill, very best modern machinery, engine and boiler complete, in best hard wheat region in the United States. Railroad front near Manitoba boundary, and largely settled with Canadians. Excellent chance. I own by accident, and sell because not a miller. Terms easy.

C. M. HERTIG,  
Box 182, Minneapolis, Minn.

**TO MILLERS**

**FOR SALE**

NATIONAL ROLLER MILLS, BRUSSELS, Ont.; capacity 100 barrels per day. Cheap, easy terms of payment. Address

"B.C.", P.O. Box 596, Toronto.

**ARE YOU INTERESTED IN LUMBER?**

It is invaluable to any who have occasion to measure lumber, cast up measurements of timber of any shape, and to farmers and mechanics, without any exception.

**THE TABLE ON STOVE AND UP-DOWN BOLTS**

and the table for casting up price per cord for these is a great saver of time, and always accurate.

Over a million copies have been sold. Post paid to any address on receipt of 35 cents. Address,

A. G. MORTIMER,  
Toronto, Can.

**MILLERS' & MANUFACTURERS' INS. CO.**

ESTABLISHED - 1885

32 Church Street, Toronto

The President, James Goldie, Esq., in moving the adoption of the report on the business of 1892, said: I have much pleasure in drawing your attention to the fact that this company has verified, in a marked degree, every expectation set forth in the original prospectus when organized in 1885.

Up to the present time the insurers with this company have made a saving, when compared with the current quoted rates, of \$91,000.00. And in addition thereto bonus dividends have been declared to continuing members amounting to \$21,500.72.

Besides achieving such result, we now also have, over all liabilities including a re-insurance reserved (based on the Government standard of 50 per cent) (\$900,000), a cash surplus of 1.25 per cent. to the amount of risk in force.

Such results emphasize more strongly than any words I could add the very gratifying position this company has attained. Therefore, with this concise statement of facts, have much pleasure in moving the adoption of the report

The report was adopted, and the retiring Directors unanimously re-elected. The Board of Directors is now constituted as follows: James Goldie, Guelph, president; W. H. Howland, Toronto, vice-president; H. N. Baird, Toronto; Wm. Bell, Guelph; Hugh McCulloch, Galt; S. Neelon, St. Catharines; George Pattinson, Preston; W. H. Story, Acton; J. L. Spink, Toronto; A. Watts, Brantford; W. Wilson, Toronto.

HUGH SCOTT, Mgr. and Secy  
THOS. WALMSLEY, Treasurer

**THOMAS McLAUGHLIN**

**FLOUR**

**GRAIN**

DEALER

210 BOARD OF TRADE BUILDING

TORONTO

EASTERN AGENCY

50 St. Paul Street

QUEBEC



**Mineral Wool Pipe and Boiler Covering**

If you want to save fuel  
" " " dry steam at long distance  
" " " to prevent condensation  
" " " cold water pipes from dripping  
" " " " freezing

USE  
MINERAL WOOL  
SECTIONAL  
COVERING

THE best non-conductor is the cheapest covering. Mineral Wool heads the list as a fire-proof non-conductor. Hard pressed coverings are poor non conductors, and are therefore the most expensive in the end.

A good pipe covering is one of your best investments. It is false economy to have uncovered pipes, as you are just paying the coal man what the covering man should have, and only ashes to shew for it. Give the matter your consideration, it means money to you.

We also carry full lines of Asbestos Goods, and Mineral Wool for fire-proofing, deadening of sound, insulation, etc., etc. Send for Pamphlet.

CANADIAN MINERAL WOOL CO. LTD., 126 BAY ST., TORONTO

**EMBRO OATMEAL MILLS**

**ROLLED OATS**

STANDARD AND

**GRANULATED OATMEAL**

Made from Selected White Oats

SPECIAL TERMS MADE WITH  
FLOUR MILLERS FOR RE-SHIP-  
MENT WITH CARLOAD FLOUR

D. R. ROSS, Embro, Ont.

**Chatham Wired Hoop Co., Ltd.**

Owner of the Patents for the Dominion of Canada

IS now issuing Licenses for the use of wooden barrel hoops with reinforcing metal band commonly called "the wired hoop." These hoops are specially serviceable for high grade cooperage, requiring strength and tightness, such as flour, meal, cement, etc.

ADDRESS COMMUNICATIONS TO  
CHATHAM WIRED HOOP COMPANY, LIMITED, CHATHAM, ONT.

**Peet & Company**

Flour and Grain Merchants

BOARD OF TRADE BUILDING

TORONTO

ESTABLISHED 1859  
**WM. GALBRAITH**

Commission Merchant

**Flour and Grain**

48 Front Street E.

TORONTO

# DID YOU KNOW IT?

MESSES. DOMINION DRY KILN CO.,  
TORONTO, ONT.

GENTLEMEN,

We have thoroughly tested the "Andrews" Lumber Dry Kiln furnished by you and must say that it more than surpasses our expectations. We put green spruce lumber in from the saw dripping with water and in 18 hours it was drier than lumber that had been stuck up in the yard all summer, and in four days it was as dry as a bone, and without nearly as many checks or warp as the same grade air dried.

A very important feature of the "Andrews" Kiln is that it saves so much steam over that of any other system.

You may refer any one you like to us, or send them down to inspect, and we can satisfy them that your kiln cannot be beat.

Yours truly,  
EASTMAN LUMBER CO.

## WHAT?

## WHY

CHATHAM, ONT.  
August 25th, 1892

V. G. MORTIMER, Esq.  
Manager Dominion Dry Kiln Co.,  
Toronto, Ont.

DEAR SIR,

The "Andrews" dry kiln, which I purchased from you has now been in operation over a month, and is so perfectly satisfactory that I cannot say enough in its favor.

I use very little steam and my staves come out as dry as a bone, and are not in any way injured by warping or discoloration.

Yours truly,  
(Signed) N. H. STEVENS

.....

AWARDED

THE

# GOLD

MEDAL

.....



.....

AT THE

# WORLD'S

# FAIR

# CHICAGO

.....

SAVES

Time

Capital

Interest

Insurance

Yard Room

Freight

Material

Labor

Expense

Nearly 500 Kilns

- already -

In Successful Operation

## THE

# ANDREWS DRYER

FOR

## Lumber, Shingles, Heading and Staves

MANUFACTURED BY

# THE DOMINION DRY KILN CO.

## TORONTO, ONT.



# COOPERAGE STOCK

If you want  
STAVES, HOOPS, HEADING OR LINERS

FOR

Flour Barrels, Meal Barrels, Apple Barrels,  
Salt Barrels, Bean Barrels or any other kind of Barrels

WRITE TO **SUTHERLAND, INNES & CO.,**  
CHATHAM, ONT.  
... THEY MAKE THE BEST STOCK ...

# RESULTS ADVERTISING

—COME FROM—

IN

Canadian Miller WRITE FOR TERMS....

# BARREL LABELS

Advertising Novelties

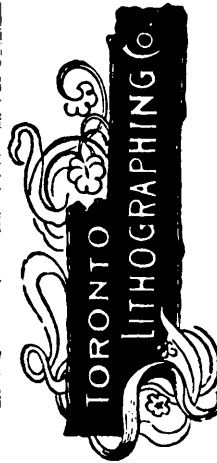

ENGRAVING OF ALL KINDS

# ... THE ... FLINT & PERE MARQUETTE RAILROAD

FROM  
Port Huron and Detroit

Is the Short Line to  
**SAGINAW AND BAY CITY**  
(Centres of the vast lumber interests of Michigan)  
**WT. PLEASANT, CLARE, REED CITY**  
**BALDWIN, LUDINGTON, MANISTEE**  
AND  
**MILWAUKEE AND MANITOWOC, WIS.**

The last two named are reached by the Company  
line of steamships across Lake Michigan.  
The line thus formed is a short and direct route from  
**NEW YORK BUFFALO TORONTO**  
to **ST. PAUL, DULUTH** and Pacific Coast points.  
Write either of the undersigned for Folders, which  
contain Maps, Train Schedules and much information  
of value to those contemplating a trip to any of the  
above-mentioned points.

**W. M. BALDWIN, JR.,** General Manager.  
**W. F. POTTER,** Gen'l. Supt.  
**A. PATRIARCHE,** Traffic Manager.  
GENERAL OFFICES: - **SAGINAW, MICH.**

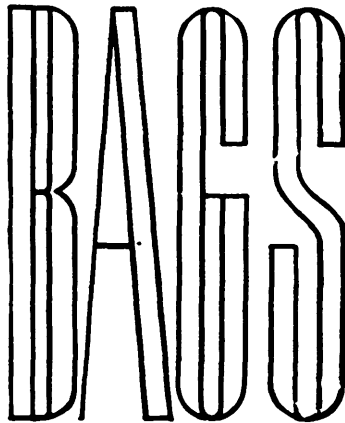

## JUTE AND GOTTON HOME TRADE AND EXPORT FOR ALL PURPOSES

DESIGNS FOR BRANDS WITHOUT CHARGE  
ARTISTIC PRINTING A SPECIALTY

### Consumers Gordage Co. Ltd. MONTREAL

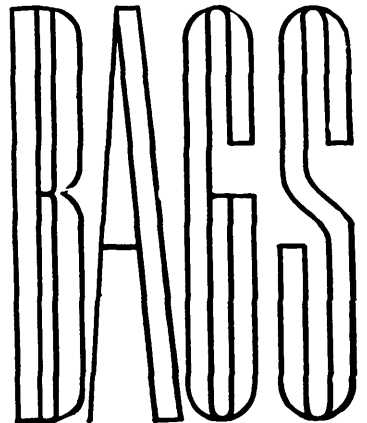

## 35 CENTS BUYS FISHER'S GRAIN TABLES

The book contains more valuable information and  
useful tables for Farmers, Millers, Traders and others  
than any similar book of its kind ever published. In-  
cludes being a complete Ready Reckoner showing the  
value of articles or lbs. from one to ten, from a quarter  
of a cent to \$2000. Also tables for Grain, Hay, Rent,  
Board, Wages, Interest, etc.

Write for sample copy  
**THE CANADIAN MILLER,**  
Toronto, Ont.

## U.S. MYERS' ROYAL CATTLE SPICE

TESTIMONIAL.  
DEPARTMENT OF AGRICULTURE,  
ONTARIO,  
Toronto, March 17th, 1893.  
Gentlemen: We have used Myers' Royal Cattle Spice  
during the present winter with both cattle and sheep.  
It seems to be equally valuable for both. I noticed  
especially the benefit on a lot of yearling rams. The  
change in their appetite and appearance was easily  
perceived after the first week or ten days feeding, and  
they have steadily and rapidly gained since. Yours  
very truly,  
(Signed) JOHN DAVIES,  
Myers, Myers & Co., Toronto

## JAMES DICKSON

FINANCIAL AGENT  
ASSIGNEE  
COLLECTING ATTORNEY  
ETC.

Room 17 Manning Arcade  
.. Toronto  
— TELEPHONE 68 —

### THE BEST ROOFING METALLIC ROOFING

## FRED. ROPER

Trustee, Accountant, Auditor, etc.

QUEBEC BANK CHAMBERS  
2 TORONTO STREET Phone 1714

"BUILD TO-DAY THEN,  
STRONG AND SURE,  
WITH A FIRM AND  
AMPLE BASE."  
— Longfellow.

### DO YOU?

WISH THIS TO BUILD  
an advertisement  
in the  
**CONTRACT-  
RECORD.**  
TORONTO  
will bring you  
orders from the  
best contractors.

SUBSCRIBE FOR ...

## Canada Lumberman

YOU'LL LIKE IT

ADDRESS: TORONTO

### FOR TRUSSES RUPTURE

INSTRUMENTS FOR  
CLUB FEET,  
WHITE SWELLING,  
SPINAL CURVATURE,  
SALLS,  
DEFORMITIES

**CHAS CLUTHE** 134  
OPPOSITE BARRICK HOUSE  
TORONTO, CAN.  
ESTABLISHED 1877

### DUST! DUST!

Gilbe's Patent Dust Protector  
protects the nose and mouth from  
inhalations of poisonous dust. In-  
valuable to operators in every in-  
dustry where dust is troublesome.  
Protects children and perfect ventilation.  
Patented in U.S.A. and Canada.  
Gilbe's Respirator Co., 36 LaSalle St., Chicago.



BRANDS:  
 STAR : LINCOLN  
 CROWN  
 RED CROSS  
 CLYDE MILLS  
 SPARKLING RIVER

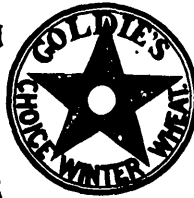

Unsurpassed for Uniform Quality



GREENFIELD MILLS + AYR. ONT.  
 D. GOLDIE, Prop.

Daily Capacity 500 Barrels



3 1/2 Cents a day —

That isn't much money, is it?

About twenty-five cents a week or so.

And a man must be pretty hard up if he hasn't that much to spend every week.

Times are hard, they say; but if they are hard now to your family and yourself, what will they be to your family with ut you?

That's worth thinking about.

We think that no man should be without life insurance when it can be had at such a low rate as 3 1/2 cents a day from the Manufacturers' Life, Yonge Street, corner Colborne, Toronto.

Write to us and we will give you all particulars.

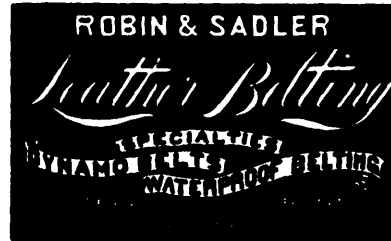

Send for sample of our new SAWMILL BELT



- Royal Mills, capacity 1,200 bb
- City Mills, 1,100 bbls
- Glenora Mills, 1,000 bbls.
- Goderich Mills, 1,000 bbls.
- Seaforth Mills, 600 bbls.
- Winnipeg Mills, 1,000 bbls

DAILY CAPACITY  
 7,100 BBLs.

HIGHEST QUALITY

☀ Hungarian Patents AND Strong Bakers' ☀

FLOUR

W. W. OGILVIE  
 PROPRIETOR

HEAD OFFICE:  
 MONTREAL, QUE.

FIRST PRIZE, DIPLOMA AND  
 GOLD MEDAL, EXHIBITION,  
 JAMAICA . . . .

# PLANSIFTER COMPANY

OF  
CANADA, LTD.

STRATFORD, ONT.

We have the SOLE RIGHT to manufacture and sell the Plansifter in the Dominion of Canada  
Patents of CARL HAGGENMACHER, of Budapest, Hungary

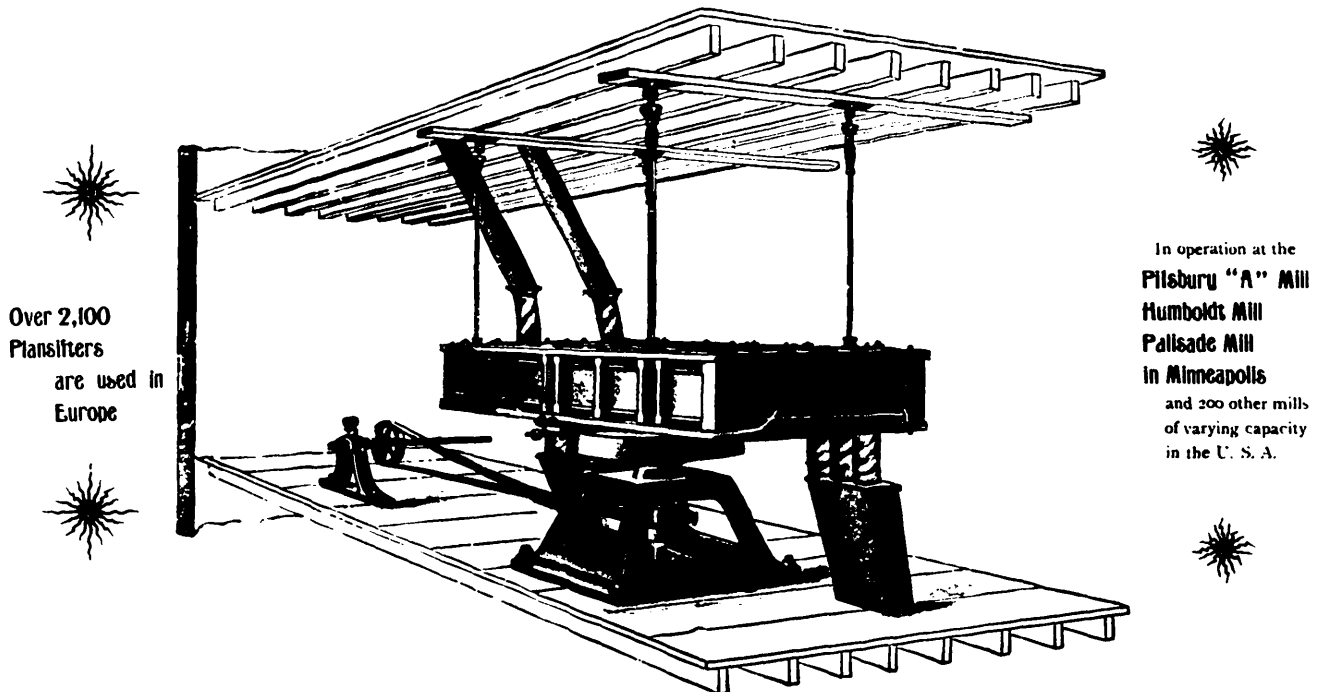

Over 2,100  
Plansifters  
are used in  
Europe

In operation at the  
Pillsbury "A" Mill  
Humboldt Mill  
Palsade Mill  
in Minneapolis  
and 200 other mills  
of varying capacity  
in the U. S. A.

**One Single Plansifter** will do the entire Scalping, Grading and Bolting of a mill of 40 to 60 barrels capacity

The Plansifter requires **LITTLE POWER** about one and one-half h.p. to drive, runs smooth and easy.

The Plansifter requires **LITTLE ROOM**, it does the work of 5 to 10 scalpers or reels.

The Plansifter does **BETTER WORK**, makes sharper pure flour than any other machine in the market.

The **SIKES** of the Plansifter **KEEP PERFECTLY CLEAN** without the use of brushes.

THE **PLANSIFTER DOES THE WHOLE BOLTING PROCESS.**

**PERFECT SUCCESS ON GERM, BAKERS AND LOW GRADE STOCK**, either wheat or rye.

SEE MACHINES AT WORK  
IT IS YOUR OWN INTEREST

APPLY FOR CIRCULARS, PRICES AND ESTIMATES TO

THE PLANSIFTER COMPANY OF CANADA, LIMITED - - STRATFORD, ONT.

# The Best is Cheapest in the End

Are always in better working condition  
Produce better results  
Don't have to be corrugated and ground so often

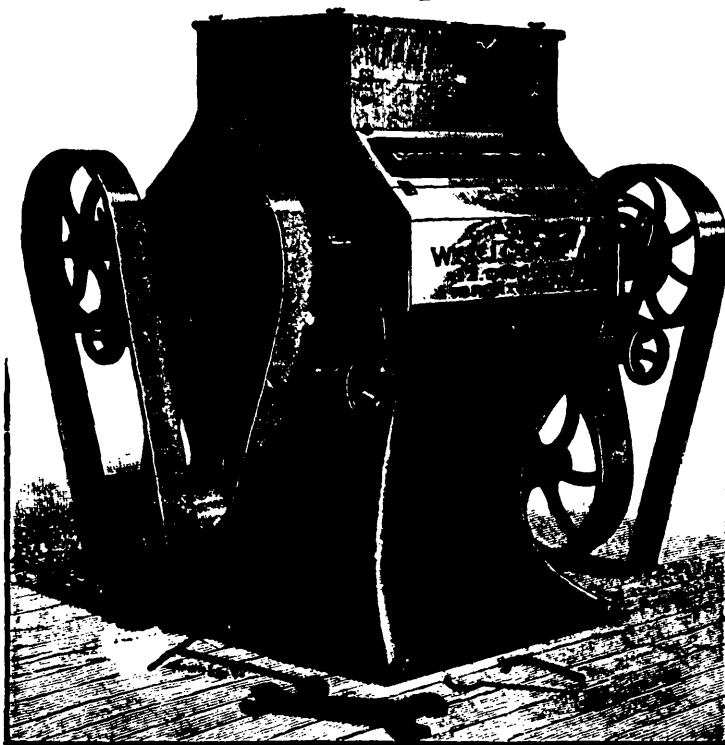

Mill don't have to shut down for repairs  
Makes more money  
Considerable saving in expense

## GREY ROLLS

ARE SO HARD AND TOUGH

LAST TWICE AS LONG AS OTHERS

..... Guaranteed to be absolutely free from any flaw .....

GREY ROLLS ARE THE BEST

Old Rolls ground and corrugated with the utmost precision

..... Warranted perfectly true, and returned promptly

**OUR ROLL GRINDING AND CORRUGATING PLANT** is the largest, best equipped and most accurate in the country; our stock of Corrugating Tools the most varied. New Corrugating Tools of any style made to order with the greatest nicety.

MANUFACTURED BY

**W.M. & J. G. GREY** 2 CHURCH ST.  
GORONGO

# DICK, RIDOUT & CO.

JUTE AND COTTON

## BAGS AND SACKS

OF EVERY QUALITY AND SIZE REQUIRED.

Strict attention given to prompt shipment.

Original Designs for Brands Prepared Free . . . Printing in beautiful Bright Colors at Lowest Prices

SEND FOR SAMPLES  
AND PRICE LIST



**DICK, RIDOUT & CO., TORONTO, ONT.**

### Actual Results

NET PREMIUMS  
PAID TO THE

### ONTARIO MUTUAL LIFE

on an ordinary Life Policy of \$1,000,  
No. 1130 during its first 20 years,  
issued for age 37.

In 1872	Had \$4.57	In 1877	Had \$100.00
1872	20.52	1877	12.75
1874	20.52	1878	11.75
1875	24.71	1879	11.25
1877	20.52	1880	11.25
1877	20.52	1877	12.75
1877	20.52	1877	12.75
1879	11.00	1879	12.41
1885	12.75	1879	11.25
1881	12.75	1881	11.25

Total Paid in 20 years \$321.99

### F. E. DIXON & CO.

MANUFACTURERS OF

## Star Rivet LEATHER BELTING

70 KING ST. EAST

WRITE FOR  
DISCOUNTS

Toronto

1892 MODEL

### Remington Typewriter



Unapproached for Excellence of Design and Construction, Quality of Work, Simplicity and Durability.

EST. MACHINES FOR RENTAL TO  
OPERATORS SUPPLIED SEND FOR CIRCULAR

GEORGE BENGOUGH

SPACKMAN & CO.

-45-

Adelaide St. East

144 St. James Street

Tel. 1207. TORONTO

Tel. 1189 MONTREAL

## BAGS

For  
FLOUR  
OATS  
BRAN  
FEED

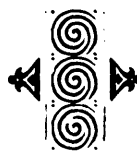

## BAG PRINTING IN COLORS

A SPECIALTY

... DESIGNS FURNISHED FREE ...  
and the Best Work guaranteed

PRINTING CAPACITY 15,000 BAGS DAILY

Every Size and Quality in stock  
The Largest and Best Equipped Bag Factory in Canada

### HESSIANS or BURLAPS

We carry the Largest and Best Assorted  
Stock in the Dominion.

## THE CANADA JUTE COMPANY LIMITED

15, 17, 19 AND 21 ST. MARTIN STREET, MONTREAL

Toronto Agent: FRANK T. BARR, 48 Wellington Street East, Toronto

C. C. GIBLIN & F. E. COLEMAN

### J. L. Goodhue & Co.

MADE IN U.S.A.  
LEATHER  
BELTING . . .

AND  
LACE LEATHER

DANVILLE, Que.

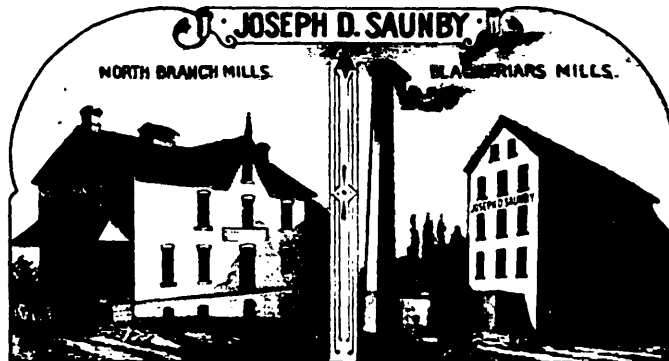

Manufacturer of . . .

### High Grade Flours

Brands:

"ANSONIA"

AND

"GECUMSEH"

Chopped Feed . . .

In whole or car lots  
mixed

NEW & 2nd HAND  
ILLUSTRATED CATALOGUE  
FREE MACHINERY

~LONDON, ONT.~