

Technical and Bibliographic Notes / Notes techniques et bibliographiques

The Institute has attempted to obtain the best original copy available for filming. Features of this copy which may be bibliographically unique, which may alter any of the images in the reproduction, or which may significantly change the usual method of filming, are checked below.

L'Institut a microfilmé le meilleur exemplaire qu'il lui a été possible de se procurer. Les détails de cet exemplaire qui sont peut-être uniques du point de vue bibliographique, qui peuvent modifier une image reproduite, ou qui peuvent exiger une modification dans la méthode normale de filmage sont indiqués ci-dessous.

Coloured covers/
Couverture de couleur

Coloured pages/
Pages de couleur

Covers damaged/
Couverture endommagée

Pages damaged/
Pages endommagées

Covers restored and/or laminated/
Couverture restaurée et/ou pelliculée

Pages restored and/or laminated/
Pages restaurées et/ou pelliculées

Cover title missing/
Le titre de couverture manque

Pages discoloured, stained or foxed/
Pages décolorées, tachetées ou piquées

Coloured maps/
Cartes géographiques en couleur

Pages detached/
Pages détachées

Coloured ink (i.e. other than blue or black)/
Encre de couleur (i.e. autre que bleue ou noire)

Showthrough/
Transparence

Coloured plates and/or illustrations/
Planches et/ou illustrations en couleur

Quality of print varies/
Qualité inégale de l'impression

Bound with other material/
Relié avec d'autres documents

Continuous pagination/
Pagination continue

Tight binding may cause shadows or distortion along interior margin/
La reliure serrée peut causer de l'ombre ou de la distorsion le long de la marge intérieure

Includes index(es)/
Comprend un (des) index

Title on header taken from:/
Le titre de l'en-tête provient:

Blank leaves added during restoration may appear within the text. Whenever possible, these have been omitted from filming/
Il se peut que certaines pages blanches ajoutées lors d'une restauration apparaissent dans le texte, mais, lorsque cela était possible, ces pages n'ont pas été filmées.

Title page of issue/
Page de titre de la livraison

Caption of issue/
Titre de départ de la livraison

Masthead/
Générique (périodiques) de la livraison

Additional comments:/
Commentaires supplémentaires:

This item is filmed at the reduction ratio checked below/
Ce document est filmé au taux de réduction indiqué ci-dessous.

10X	12X	14X	16X	18X	20X	22X	24X	26X	28X	30X	32X
<input type="checkbox"/>	<input type="checkbox"/>	<input type="checkbox"/>	<input type="checkbox"/>	<input type="checkbox"/>	<input type="checkbox"/>	<input type="checkbox"/>	<input type="checkbox"/>	<input type="checkbox"/>	<input type="checkbox"/>	<input checked="" type="checkbox"/>	<input type="checkbox"/>

THE Canadian

Mining

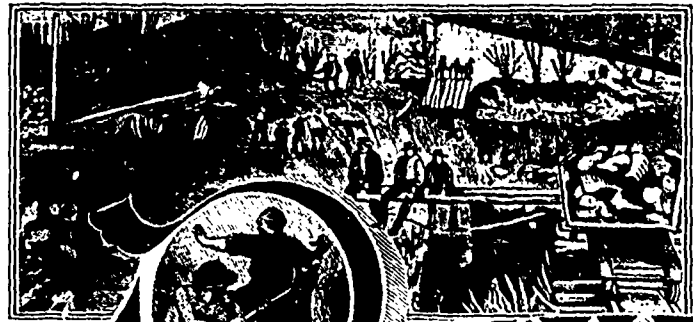

REVIEW

Established 1882.

Vol. VI.—No. 2.

1888.—OTTAWA, FEBRUARY—1888.

Vol. VI.—No. 2.

Hamilton Powder

COMPANY,

Manufacture Mining, Blasting, Military and Sporting

Gunpowder,

DYNAMITE, DAULIN, and the new

ECLIPSE MINING POWDER

DOMINION AGENTS FOR

Safety Fuse, Electric Blasting Apparatus, &c.

OFFICE

103 ST. FRANCOIS XAVIER STREET
MONTREAL.

Branch Office & Magazines at all chief distributing points in Canada.

GEO. G. BLACKWELL,
26 Chapel Street, Liverpool.

Handles by Purchase or on Sale
MANGANESE, PHOSPHATE,
Asbestos, Antimony Ore, Mica and
all Ores, Minerals, &c.

Correspondence Solicited.

Canada

Powder
Company.



BLASTING MATERIAL.

BROCKVILLE, ONT.

Miller Bros. & Mitchell,

MANUFACTURERS OF

Steam Rock Drills

AND

HOISTING ENGINES,

Mining & Contractors' Pant,
&c., &c.

110 TO 120 KING STREET, MONTREAL, QUE.

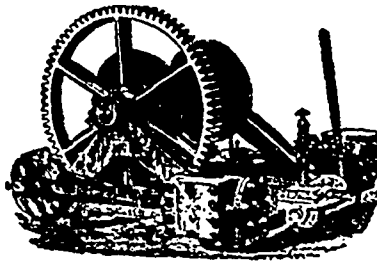

Scott's Portable Forge,

MANUFACTURED BY

H. R. Ives & Co.,

MONTREAL.

MANUFACTURERS OF

Hardware, Stoves, Iron Bed-
steads, Soil Pipe, Iron
Railings

HEAVY AND LIGHT
CASTINGS
TO ORDER.

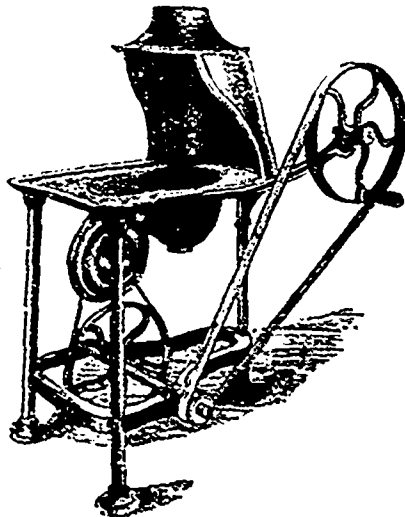

Fenwick & Sclater,

Asbestos and Soapstone.

MINES:

Coleraine and Victoria,

PROVINCE OF QUEBEC.

STEAM USERS SUPPLIES

OF EVERY KIND.

OFFICES:

229 Commissioners Street,
414 St. Paul Street,
MONTREAL.

BENNY, MACPHESON & Co.,

WHOLESALE

IRON, STEEL

AND

General Hardware Merchants.

Headquarters for Railway, Mining and
Contractors' Supplies.

388, 390 & 392 St. Pau St.
MONTREAL.

Iron and Steel Stores, Debresoles St.

Stewart & Fleck, Jr.,

Manufacturers of every Description of

Mill Machinery,

Water Wheels, Steam Engines,
Bollers, Derricks, Steam
Pumps and Mining
Machinery.

Brass and Iron Casting of every
Description.

VULCAN IRON WORKS, WELLINGTON ST
OTTAWA.

T. STEWART.

ALEX. FLECK, JR.

THE

BELL TELEPHONE CO.

OF CANADA.

ANDREW ROBERTSON, . . . PRESIDENT
C. F. SISE, . . . VICE-PRESIDENT
C. P. SCLATER, . . . SECRETARY-TREASURER

HEAD OFFICE, . . . MONTREAL.

H. C. BAKER, Manager Ontario Department,
HAMILTON.

This Company will sell its instruments at prices ranging from \$10 to \$25 per set. These instruments are under the protection of the Company's patents, and purchasers are therefore entirely free from risk of litigation.

This Company will arrange to connect places not having telegraphic facilities with the nearest telegraph office, or it will build private lines for firms or individuals, connecting their places of business or residences. It is also prepared to manufacture all kinds of electrical apparatus.

Full particulars can be obtained from the Company's offices at above, or at St. John, N.B., Halifax, N.S., Winnipeg, Man., Victoria, B.C.

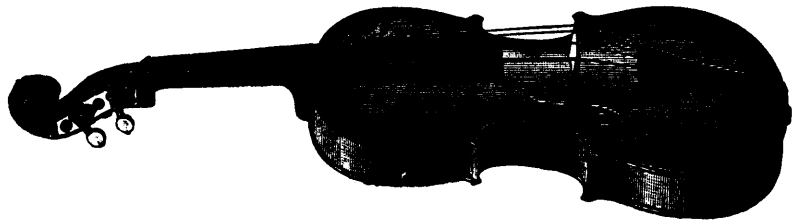

HAVING a very large stock of Violins, I will sell them at the following reduced rates until the 1st of February, 1888, viz:—

VIOLINS FROM \$3 TO \$12,
AT HALF PRICE. AND
VIOLINS FROM \$15 TO \$30
AT ONE THIRD OFF, ALSO

Other Musical Instruments at Greatly Reduced Prices.

ORDERS BY MAIL RECEIVE OUR PROMPT AND CAREFUL ATTENTION.
ILLUSTRATED CATALOGUES FREE ON APPLICATION.

"ESTABLISHED 1868."
THOS. CLAXTON,

Importer and Dealer in Music and Musical Instruments.
137 YONGE STREET, TORONTO, CANADA.

Black Diamond Steel



THE VERY FINEST STEEL

For Miners' Use

Will hold a Good Edge and Save Money in Blacksmithing.

LARGE STOCK

Always kept at our MONTREAL BRANCH HOUSE, or can be delivered promptly from Works at Pittsburg. Address

PARK, BROTHER & CO.,
LIMITED,
377 ST. PAUL STREET,
MONTREAL.

The Canada Co.

Will issue Licences to Prospect or to work Minerals on any of their Mining Lands and Mineral Reservations,

Covering nearly a

Quarter of a Million Acres

In Eastern Ontario, and principally within the belts containing

Iron, Phosphate, Gold, Galena, Plumbago, Mica, Marbles, Building Stone, and other valuable Minerals.

For list of lands and terms apply to the Company's Mining Inspectors,

H. T. STRICKLAND,
Peterborough, Ont.,

For lands in the County of Hastings and westward, and to

ANDREW BELL, P.L.S.,
Almonte, Ont.,

For lands East of the County of Hastings.

TO MINERS AND OTHERS.

Bannerman & Powers,

VULCAN BOILER WORKS,

428 and 340 Wellington St., Ottawa.

MANUFACTURERS OF

IRON AND STEEL BOILERS

OF EVERY DESCRIPTION.

Tanks, Girders, Iron Roofing, Bank Vaults, Smoke

Stacks

—AND ALL KINDS OF—

SHEET IRON WORK.

Repairs Neatly and Promptly Executed

MICA WANTED.

EVERY quantity of selected quality cut in square from 2 x 3 to the largest sizes which exist, or slabs to be cut in squares of the told sizes. Samples with lowest prices and notice of quantity and term of delivering may be addressed to **Max. Raphael, Breslau, Germany.**



NOTICE RESPECTING PASSPORTS.

PERSONS requiring passports from the Canadian Government should make application to this Department for the same, such application to be accompanied by the sum of four dollars, in payment of the official fee upon passports as fixed by the Governor-in-Council.

G. POWELL,
Under Secretary of State.

OTTAWA, 19th Feb., 1886.

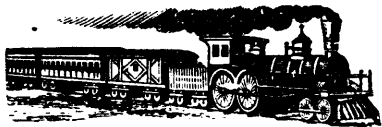

THE INTERCOLONIAL RAILWAY OF CANADA.

THE ROYAL MAIL PASSENGER AND FREIGHT BOATS BETWEEN CANADA AND GREAT BRITAIN

—AND THE—

Direct Route between the West and all points on the Lower St. Lawrence and Baie des Charleux, also New Brunswick, Nova Scotia, Prince Edward Island, Cape Breton, Newfoundland, Bermuda and Jamaica.

New and Elegant Buffet Sleeping and Day cars run on through express trains.

Passengers for Great Britain or the Continent by leaving Toronto at 8.30 a.m. train, Thursday, will join outward Mail Steamers at Halifax a.m. Saturday.

Superior Elevator, Warehouse and Dock accommodation at Halifax for shipment of grain and general merchandise.

Years of experience have proved the Intercolonial in connection with Steamship lines to and from London, Liverpool and Glasgow to Halifax, to be the quickest freight route between Canada and Great Britain.

Information as to Passenger and Freight rates can be had on application to

E. KING,
Ticket Agent,
27 Sparks Street,
Opposite the Russell, OTTAWA.

ROBT. B. MOODIE,
Western Freight and Passenger Agent,
93 Rossin House Block,
York St., TORONTO.

D. POTTINGER,
Chie. Superintendent,
Railway Office, Moncton, N.E.
Nov. 22nd, 1886.



Department of Inland Revenue.—An Act respecting Agricultural Fertilizers.

The public is hereby notified that the provisions of the Act respecting AGRICULTURAL FERTILIZERS came into force on the 1st of January, 1886 and that all Fertilizers sold thereafter require to be sold subject to the conditions and restrictions therein contained—the main features of which are as follows:

The expression "fertilizer" means and includes all fertilizers which are sold at more than TEN DOLLARS per ton, and which contains ammonia, or its equivalent of nitrogen, or phosphoric acid.

Every manufacturer or importer of fertilizers for sale, shall, in the course of the month of January in each year, and before offering the same fertilizer for sale, transmit to the Minister of Inland Revenue, carriage paid, a sealed glass jar, containing at least two pounds of the fertilizer manufactured or imported by him, with the certificate of analysis of the same, together with an affidavit setting forth that each jar contains a fair average sample of the fertilizer manufactured or imported by him; and such sample shall be preserved by the Minister of Inland Revenue for the purpose of comparison with any sample of fertilizer which is obtained in the course of the twelve months then next ensuing from such manufacturer or importer, or collected under the provisions of the Adulteration Act, or is transmitted to the chief analyst for analysis.

If the fertilizer is put up in packages, every such package intended for sale or distribution within Canada shall have the manufacturer's certificate of analysis placed upon or securely attached to each package by the manufacturer; if the fertilizer is in bags it shall be distinctly stamped or printed upon each bag; if it is in barrels, it shall be either branded, stamped or printed upon the head of each barrel or distinctly printed upon good paper and securely pasted upon the head of each barrel, or upon a tag securely attached to the head of each barrel; if it is in bulk, the manufacturer's certificate shall be produced and a copy given to each purchaser.

No fertilizer shall be sold or offered or exposed for sale unless a certificate of analysis and sample of the same shall

have been transmitted to the Minister of Inland Revenue and the provisions of the foregoing sub-section have been complied with.

Every person who sells or offers or exposes for sale any fertilizer, in respect of which the provisions of this Act have not been complied with—or who permits a certificate of analysis to be attached to any package, bag or barrel of such fertilizer, or to be produced to the inspectors to accompany the bill of inspection of such inspector, stating that the fertilizer contains a larger percentage of the constituents mentioned in sub-section No. 11 of the Act than is contained therein—or who sells, offers or exposes for sale any fertilizer purporting to have been inspected, and which does not contain the percentage of constituents mentioned in the next preceding section—or who sells or offers or exposes for sale any fertilizer which does not contain the percentage of constituents mentioned in the manufacturer's certificate accompanying the same, shall be liable in each case to a penalty not exceeding fifty dollars for the first offence, and for each subsequent offence to a penalty not exceeding one hundred dollars. Provided always that deficiency of one per centum of the ammonia, or its equivalent of nitrogen, or of the phosphoric acid, claimed to be contained, shall not be considered as evidence of fraudulent intent.

The Act passed in the forty-seventh year of Her Majesty's reign, chaptered thirty-seven and entitled, "An Act to prevent fraud in the manufacture and sale of agricultural fertilizers," is by this Act repealed, except in regard to any offence committed against it or any prosecution or other act commenced and not concluded or completed, and any payment of money due in respect of any provision thereof.

A copy of the Act may be obtained upon application to the Department of Inland Revenue, as well as a copy of a Bulletin which it is proposed to issue in April, 1888, concerning the fertilizers

E. MIALL,
Commissioner.

15th Dec., 1887.

we believe will be very largely extended this year, the article we allude to will doubtless be frequently consulted by those interested in silver mining. A remarkable fact is noticed by Mr. Ingall, namely, that there is a vast difference between the official records of silver exported from 1871 to 1875, and the published returns of silver produced. Now, as Canada is not a country which consumes much silver in its unmanufactured condition, this discrepancy is not readily accountable. This fact alone shows of what value Mr. Coste's work will be from year to year, for reference and for information, which may be looked upon as official. Silver mining bids fair to become one of the most valuable of Canadian mining industries.

Mining Around Port Arthur.

A correspondent resident at Port Arthur, and who, although not personally interested in any of the mines there, is a close observer of mining operations, and everything pertaining thereto, sends us the following remarks relative to the work carried on last year (1887). His observations are reliable.

"Mining operations have been carried on very energetically during the year. Upwards of ten thousand acres of mineral lands were purchased from the Ontario Government during the past twelve months, principally iron lands, explorers having traced the rich iron deposit of northern Minnesota into Canadian territory. Active steps will be taken in the early spring to develop these and other properties which will necessitate the expenditure of a large amount of capital and give employment to a great number of men.

"The most phenomenal success in the district is the 'Beaver' silver mine, which, during three months last summer, returned to its owners all the money (about \$200,000) previously invested in working it. Nearly all the other properties on which work has been progressing continue to improve, and it is not improbable that within the next year half a dozen mines may be working quite as successfully as the 'Beaver.'

"The completion of the Port Arthur, Duluth and Western Railway from Port Arthur to the international boundary will greatly facilitate mining operations, not only in the iron but in the silver and gold districts contiguous to this route. Ten miles have been graded this fall, and the timber and ties necessary for the completion of the first twenty miles are on the ground, and it is expected that forty miles will be in operation by 1st July next. This road will also tap a large area of pine timber lands near the boundary which is at present the property of the Provincial Government, and open up a large tract of good agricultural land."

The Nanaimo Explosion.

The details of the terrible disaster at the Wellington Colliery, with its melancholy list of dead, cannot fail to awaken in the hearts of our readers feelings of profound sympathy for the unfortunate wives and families so suddenly bereaved; much suffering must necessarily exist, and we are confident that as soon as an appeal is made for pecuniary assistance the

public will respond with a ready and liberal hand.

The mine has always been regarded as the best arranged and ventilated on the island, and practical men state that its equipment could not have been better. Only a few days before, in accordance with regulations, it had been thoroughly inspected by practical men who reported it to be in the best possible condition. Until the result of the Enquiry has been made known the cause of the deplorable occurrence can only be conjectured. Mr. E. G. Prior, M. P., who inspected the mine shortly after the explosion, examined the faces of all the levels and stalls, and is firmly of opinion that the primary cause of the explosion was a blown-out shot in the face of the main east level. Everything goes to prove that the explosion started from there. All the timbers are blown from that point, and there is a thick coating of soot on that side of all the rock and timbers. A miner's powder canister capable of holding about four pounds, was found within twenty-one feet of the blown-out shot, and the shot itself points in a direct line for the can. The contents of this can had exploded. Some dozen other cans, more or less, full of powder were found in different parts of the levels, headings, &c., where the explosion had passed through, the contents of which had not exploded. Mr. Prior is quite confident that gas played no part in the explosion, but that the latter was started by a blown-out shot, which discharged the powder-can and ignited the coal dust. The mine though dry, is by no means dusty, and is one which, under ordinary circumstances, he would consider perfectly safe from explosion by coal dust.

We are glad to see that the miners are insisting upon practical miners only being allowed to sit on the Enquiry. We need hardly add that in the interests of the mining community a searching investigation must be made with a view to adopting preventative measures for the future.

Prospecting Licenses for Gold.

In striking contrast to the shameful apathy and negligence of the Provinces of Ontario and Quebec, the Provincial Legislature of Nova Scotia has always had the true interests of the mining community at heart, and by many wise enactments has done much to foster and encourage the development of the resources of the province. This is shewn by the rapid progress and prosperity of the industry, and by the large and increasing revenue annually derived from it by the local treasury. There is, however, still room for improvement, particularly in the present system of granting Prospecting Licenses for Gold, as may be gathered from the following practical remarks made by the Commissioner of Mines:

"These licenses are granted for six months, with an option of renewal. Their location and renewal has led to much confusion and trouble in new districts, as they

are frequently selected almost at random for speculative purposes, and mistakes arise when portions of them are selected for leasing, etc. In view also of the large extent of ground covered by leases which are practically unforfeitable, the following suggestion may be worth consideration. This is briefly that the system of granting prospecting licenses be abolished, that leases be issued for any term decided on, say 20 or 30 years, to be held by labour or annual rental. That on the non-performance of the labour or non-payment of the rental the lease be thereby forfeited without recourse to any court of investigation or forfeiture. To give an opportunity to those who may be desirous of prospecting, the cost of the lease for the first year could be made the same as that of a prospecting license of equal extent, but if the lessee desired to continue his operations he should then before the close of the first year secure the continuation of the lease for another year by payment of the permanent rental, and so on. An arrangement similar to this would, on the basis of a small annual rental, of say \$1.00 an area, prove a boon to the prospector, for under the present arrangement he would pay for a prospecting license of one area for 12 months, 75 cents, then for a lease \$2.00, in all \$2.75. This secures him the ground for say two years; if he did not work, his lease would be liable to forfeiture. Under the proposed arrangement the same sum would secure to him his area for three years. This arrangement would also give the Province a revenue from the numerous unworked leases now hindering exploration and probable discovery of valuable ground in all our mining districts, stimulate the holders to work, and give a security and fixity of title to leases, which is desirable in the interests of investors. Provision could be made to protect properties on which any temporary cessation of work was necessary, or which were in litigation, and to prevent injustice to any prior occupant who had made any bona fide expenditure."

We commend these able suggestions not only to the careful consideration of the legislators of Nova Scotia but also to the local governments throughout the country, where they are equally applicable.

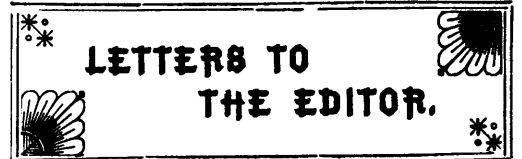

We invite Correspondence upon matters consistent with the character of the REVIEW.

Be as brief as possible. The writers name in all cases required as a proof of good faith.

One dozen copies of the issue containing his communication will be mailed free to any correspondent on request.

We do not hold ourselves in any way responsible for the opinions expressed in this section of the REVIEW.

The Dominion Mining Laws.

OTTAWA, 8th January, 1888.

The Editor

THE CANADIAN MINING REVIEW.

SIR,—I have read with a good deal of interest Mr. Nettle's letter to you, dated the 20th ultimo. It is quite clear that Mr. Nettle has not read the Canadian Mining Regulations for himself, but has accepted as true the construction placed upon them by somebody who has had an interest in misrepresenting them. There is not a solitary provision in these Regulations which would justify Mr. Nettle's denunciation of speculative companies and land sharks, etc. There is no objection, now that Mr. Nettle is apparently an American citizen, to his praise of the laws of his own country, but I take the opportunity of saying that it would puzzle him to produce a tittle of evidence in support of his strictures on the Canadian Mining Laws which are contained in the letter addressed to your paper. Mr. Nettle condemns the \$5 entry fee imposed under the Canadian Mining Regulations, but conveniently forgets to mention that there are free miners' licenses, poll-taxes, fees to the Mining Recorder, and other specious modes of levying upon the prospector resorted to in every State and Territory of the American

Union, which find no counterpart anywhere within the Canadian North-West, to which the Canadian Mining Regulations more particularly refer.

I am, yours respectfully,
CANADIAN.

Our Undeveloped Resources.

OTTAWA, 20th Feb., 1888.

The Editor

THE CANADIAN MINING REVIEW:

SIR,—I am very glad to see that the question of the development of Canada's mineral resources is being so well ventilated at present, and hope that the agitation now going on may lead to some really practical steps being taken in this direction.

That there is a great necessity for something to be done has been patent for years to all those who know anything of the development of mining districts in other countries, but, unfortunately, the mining community form too small a portion of the population to make their voice heard, and their want of any organization whose function it would be to champion their rights, still further lessens their weight in the legislative councils of the land. Mr. A. O. Lawson, of our Survey, in an article recently contributed to the *Toronto World*, has very ably represented these views.

Unfortunately, it is very difficult to convince the rest of the community of the necessity for these steps, and one can well understand how hard it is for those only familiar with the development of the farming and lumbering resources of the country to realise that the mineral resources require any different treatment.

The fact remains nevertheless, and the principles which have been found successful elsewhere will have to be followed before we can do anything with our mining districts, beyond having spasmodic "booms" at long intervals which never end in anything useful, and do an immense amount of harm.

The principles to which I refer are those of encouraging the actual prospector and of making the holding of mineral lands conditional to working.

In these and the following remarks regarding the mining laws I am referring more particularly to those provinces with which I am acquainted, viz: Ontario and Quebec.

Now, the laws of these provinces do not attain these two ends, but, on the contrary, bring about results which will eventually prove most disastrous, and this for the reason that they offer every facility to the man with spare funds to buy up all the land upon purely speculative grounds before anything has been discovered upon it.

These results may be best illustrated by an example. A prospector starts out into the bush having expended all his savings in the purchase of the necessary outfit to enable him to carry on his campaign long enough to have a chance to find something for his exertions. He goes out into the bush far from the haunts of civilized man, and after going through the toils and dangers of his arduous calling he may be lucky enough to find indications of some good vein or deposit of mineral. He cannot now, as he should be able to do, stop and explore his find to see if it is going to be worth while for him to take it up, for unless he is very prompt he may find that someone has "got on his tracks," and surveyed and acquired the land before him; so he has to take his

chances on this point; he therefore retraces his steps to the nearest town, often a long and tedious journey by trail and water course, and there, being out of funds, must make the best terms he can with the man of spare cash in order to enable him to acquire the land and pay the expenses of taking a surveyor and party out into the wilds. Then comes the rush, not of prospectors, but of speculators, who promptly take up land all round and thus immediately put a stop to all further explorations in the vicinity, which is the very spot where both experience and common sense would lead us to look for other veins or deposits.

Even if he is able to finance it himself, by the time he has acquired the necessary length of the vein all his spare cash will have been exhausted and he will have to defer testing his find till the next season, meanwhile securing the necessary funds to do so by saving out of wages earned at other employment.

Then, when after all this, he is in a position to further test his vein he may find that it does not develop as his first and necessarily cursory examination led him to believe, and that instead of a prize he has drawn a blank, so he has to begin all over again, or, more likely, he abandons exploring under such disheartening circumstances and goes where the conditions are more favourable.

This, sir, is no imagined case, but an actual and constant occurrence with the lamentable result that the resources of the country are passing rapidly out of the grasp of the Government who only can control the development of the resources of the country for the general good of the community and for the furtherance of the growth of the nation.

Thus we find in our mining regions whole areas tied up which in size would equal any of the mining districts of England; and, needless to say, after the first discoveries which have led to this state of things exploration ceases; for who wants to make discoveries on other peoples land?

Occasionally, of course, the owners of these lands expend money in exploring them, but this is exceptional; and we find most of the property is held by parties living far from the district, whose resources and energies are expended in other pursuits and who regard their mineral locations simply as they would a ticket in a lottery which may by some chance suddenly bring them a fortune.

Besides these there are many other ways in which the present law entails hardship upon the prospector, but space will not permit me to further illustrate them here, suffice it to say that the final result is that where we should have a hundred explorers searching for the valuable mineral deposits, which undoubtedly exist in our mining regions, we now have one; and that the small capitalist, instead of fulfilling his proper part in coming to help the prospector to do the preliminary testing of deposits already found, becomes simply a speculator in mineral lands; thereby not only failing to perform his proper function, but by coming in too soon in the economic machinery actually prevents the working of the whole train and blocks discovery at the outset.

So much then for the effect of the prevalence of erroneous conception of the conditions necessary for the development of mining districts, and we find similar causes militating against the successful development of individual mines.

It is very common to find parties starting to open up mines with an altogether too limited idea of how much expenditure is required before a promising prospect can be put on the footing of

a paying mine. They think that an investment of a few thousand dollars ought to ensure continuous returns of handsome profits; and if their expectations are not realised, which, of course, they cannot be, except in very rare cases, they either give up an effort which, if carried out pluckily, would have most likely turned out very profitable in the end, or else they continue it in a half hearted way which of itself courts failure, and is very disheartening to all engaged and only delays the final failure.

Instances have frequently come under my notice where, as we say, the "eyes have been picked out" of the mine, and the company, instead of pushing on the underground development work vigorously so as to find and explore other ore bodies in their vein, have confined themselves to work in and around the first found body, and when that has all been exhausted have not the capital or pluck to do all the "dead work" necessary to put the mine again on a paying basis which should have been done in the first instance. The result is another abandoned mine about which it is almost impossible to get reliable information, so that in the absence of any evidence to the contrary, it is taken for granted that it was properly and thoroughly tested, and another failure is recorded, doing infinite damage to the reputation of the district.

In thus pointing out some of the reasons for the backwardness of the mining industry of the country, I am not, of course, appealing to the mining community, as these things are already too well known to and deplored by the profession, but hope that I may be contributing somewhat to a better realisation of the case by the outside public which end must be attained before we can get anything done.

I am, Sir, yours, etc.,

ELFRIC DREW INGALL,

(Mining Geologist of Geological Survey of Canada. Associate Royal School of Mines of England.)

Coal in Ontario.

OTTAWA, February 14th, 1888.

The Editor

THE CANADIAN MINING REVIEW:

SIR,—In the January issue of the CANADIAN MINING REVIEW, I was quite surprised to see a correspondence from Westville, N. S., from the pen of "Briton," in which that gentleman states that "during a brief sojourn in Ottawa" he was "led to believe that coal will be sooner or later found within 100 miles of that city." This important statement is then followed at the close of his communication by three questions which practically resolve themselves into two: Does the Carboniferous system in geology occur in Ontario? or in other words: are the coal measures found in the series of geological formations of Ontario?

With regard to the third question which "Briton" puts, I have only to refer him to reports on that subject where 'natural gas' has been obtained and utilized for years past, and add that an analysis of the 'gas' at East River, Pictou, N.S., would have to be made before any comparison could be instituted.

Taking first, the country surrounding Ottawa, and examining its geological history closely, i.e., taking into account the lithology, stratigraphy, and particularly the palæontology of the rock formations occurring within the limits indicated and even far beyond that, it is found to be clearly divisible into three great classes each of

which belong to and are referable to well-known and easily recognized systems in geology, as follows:—

1. The post-tertiary or post-pliocene formations, consisting of sands, marls, gravels, clays, &c., most of which were deposited in the geological epoch immediately preceding the advent of civilised man in this part of North America and in which no trace of coal can be found, so that this geological series may properly be discarded. 2. Then comes the Cambro-Silurian or Ordovician formations. These are likewise well-known and extensively developed in the Ottawa region. They are all of marine origin and were deposited along the shores or at the bottom of a great sea or ocean without interruptions or breaks in time of any kind, including all the formations from the Hudson River down to the Potsdam, viz., (in descending order) Hudson River, Utica, Trenton, Black River, Chazy, Calciferous, Potsdam. The thousands of localities where these geological formations are well known to crop out to the surface of the ground in this neighbourhood and exhibit their strata along the line of strike, have afforded geologists abundance of material for sections in which the exact sequence of the beds may be obtained, from the heavy quartzite conglomerates of the Potsdam formation resting unconformably on the contorted strata of the third or Laurentian system, followed upwards by shaly and heavy bedded sandstones which pass gradually into the Calciferous sandrock of the next formation, to the highly bituminous and fossiliferous strata of the Utica formation, which themselves pass upwards into the calcareo-arenaceous shales of the Hudson River formation.

The numerous rivers and streams of the Ottawa Palæozoic Basin which run through and over the strata, exhibit the various formations above mentioned so well that a continuous series indicating the proper succession of all the beds of the rock constituting them, has been fairly obtained and known not to present any trace of a coal seam whatever throughout the whole area and along any of the lines of outcrop. The lithological and stratigraphical characters of the whole strata as known are therefore decidedly against the occurrence of coal in the neighbourhood of Ottawa.

But the palæontological argument is by far the strongest in this question of the existence of coal in Quebec or Ontario? A very brief examination of the fossil remains which are so well preserved and so abundant in the measures about Ottawa, together with a slight knowledge of the flora and fauna of the coal period, suffice to convince even the most sanguine exponent of the existence of carboniferous rocks or productive coal measures about Ottawa, (after instituting a comparison) that the latter series of formations are not the ones occurring here at all. When the sedimentary formations of Ottawa were laid down, the carboniferous age, characterized by the occurrence of a luxuriant vegetation, consisting of gigantic tree-ferns and other low orders of plants, chiefly acrogens, was not even predicated as yet; in fact, the highest types of animal life which are known to have existed in those old Ordovician times were of a very inferior order to those of the coal period, in which "air breathers" are known to have existed in great abundance. If the carboniferous or coal-bearing rocks occurred in the Ottawa Valley or in Ontario and Quebec (where the arguments above referred to apply equally well), then the accompanying flora and fauna would be present which characterises that period in the earth's history all the world over, but neither do the rock formations of Ottawa contain coal

nor do the fossil remains entombed in their strata point to the occurrence of that extensive and useful series in this part of Canada.

The statement which your correspondent then makes regarding the strata which overlie and underlie the coal-bearing rocks of Canada, as well as those which overlie at least fifty collieries in England, viz.: that they are the same as those which we have at Ottawa, cannot at all be entertained, except from a purely general lithological standpoint. The occurrence of shalystrata, associated with limestones and sandstones, occur in nearly every system of the geological record, so that these are, by themselves, not sufficient data upon which to go; but the evidence afforded by the fossil remains, telling the exact time in the history of our planet when the rocks in which they are entombed were laid, is most conclusive and final.

Now, Sir, if the knowledge of the geological formations of Ottawa and its environs is such as to point conclusively to the fact that the carboniferous or coal-bearing rocks do not occur in this district—your present correspondent would like to know if it is not better in the light of all to "deter capitalists" from investing and sinking funds which will be entirely wasted and productive of no other results than those which have attended the labours of many who have already bored for coal at Whitby, at Levis and other parts of Canada, all of whom have learned by experience that the parties who carry on these boring operations are the sole individuals who profit thereby, and that the strata bored are of a very different nature from the coal-bearing rocks of Canada and elsewhere which are easily recognized wherever they occur.

I am, yours respectfully,
NORMAN.

The Problem Solved.

Apropos of the natural gas excitement at Ottawa, the following from the pen of a correspondent to the North Hastings Review will be read with relish:—

"I beg to advance the theory that the natural gas contributed by 211 Parliamentary representatives has been for 20 years absorbed by these porous rocks and now forms a vast reservoir which the Wallace gas company is about to tap and supply through pipes to dwellings for heat and fuel. This I submit is a plausible explanation of the source of supply, as from its heavy quality the parliamentary gas would naturally sink. The trouble will be to separate the stuff in the reservoir, for should Sir John's food be cooked with Mr. Blake's gas, it would give him the mollygrubs, and should they heat Mr. Laurier's room with Sir John's gas, the member from Quebec would be asphyxiated. This utilizing of natural gas in Ottawa is a great scheme of public economy."

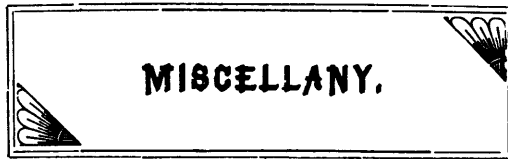

Decomposition of Chrome Iron Ore.—

C. Donath* decomposes chrome iron ore by mixing the finely powdered ore with five times its weight of barium dioxide, and heating it for half an hour in a porcelain crucible over a Bunsen burner. A greenish yellow mass is obtained, which is soluble in cold water acidulated with hydrochloric acid, the solution containing all the chromium in the form of chromic acid.

Curious if True.—In South Africa coal is reported to have been found among gold reefs. An enterprising prospector went to the *Digger News* and said, "I had both a

disappointment and success yesterday. I was looking for the main reef out near Booksburg, and had sunk a shaft 90 feet deep, when I came upon this bally stuff" (handing out a few samples of coal). Whoever would have thought of finding gold between the reefs?

A Nova Scotia Miner's Heroic Act.—

About eight o'clock on Wednesday morning, 18th ulto., the men employed about the pit mouth and buildings of the British and Colonial Land Association were started by a cry, "Run for your lives the dynamite is on fire!" When the men had fled to a place of safety, W. N. Reseigh, agent of the mine, came back and looked into the building whence the alarm had come. He noticed flames issuing from a box in which one of the contractors had dynamite fuse, detonators, etc., stored. Knowing there were men working in the shaft a few feet distant he determined to save them at any risk. He ran into another building, secured a bucket of water, and at the eminent risk of his life extinguished the flames and saved the lives of the men. He was not a moment too soon. A coil of fuse in the box was completely burned and a tin box containing detonators was scorched and blackened on all sides. The dynamite, only a few inches away, had not yet taken fire. Had he been a minute later the hero of the occurrence would not be alive to tell the tale. Mr. Reseigh is a native of Cornwall, England, and has only been in Canada a few months. By his coolness and pluck many lives were saved, and the destruction of thousands of dollars worth of property avoided.

A Lesson in Cheap Mining.—

Any facts serving to show how, with proper care and intelligence, the expenses of mining and reducing free milling gold ore may be carried on, cannot be republished too often. Therefore we give the following facts, taken from the *Financial and Mining Record*, of the Spanish mine in Nevada county, California. The figures given relate to operations in the month of November, and, we may add, are sworn to by the mine superintendent, F. W. Bradley, as required by law in this instance. The record is as follows:

MINE.			
Thirty days work produced 4,057 tons of ore.			
Cost of production.	Labor.	Supplies.	Total.
Extracting ore.....	\$679 63	\$196 65	\$876 28
Delivering ore to mill..	193 25	13 69	206 94
Dead work.....	100 90	14 35	115 25
General expense	70 70	4 75	75 45
Total.....	\$1,044 48	\$229 44	\$1,273 91
Cost per ton.....	25 8-10 c.	5 6-10 c.	31 4-10 c.
MILL.			
Twenty-nine days' work reduced 4,047 tons of ore.			
Cost of reduction.	Labor.	Supplies.	Total.
Mill expense.....	\$225 67	\$162 82	\$388 49
Water for power	5 00	198 00	203 00
Handling ore.....	177 00	2 40	179 40
General expense.....	70 71	4 75	75 46
Total.....	\$478 38	\$367 97	\$846 35
Cost per ton.....	11 8-10 c.	9c.	20 8-10 c.
Bullion produced.....			\$2,644 57
Total expense.....			2,120 27
Profit.....			\$524 30

This shows the ore to have worked only a trifle over sixty-five cents per ton. Cost of mining and milling combined was about fifty-two cents per ton. In working this large amount of ore a net profit of only thirteen cents per ton was made, the total profit being \$524.30 on 4,047 tons of ore. As we have remarked before,

the mine is worked under exceptionally favorable circumstances, and the ore is easily reduced; but it is surprising to know that under any conditions a profit, however small, can be made out of such very low grade rock. Water power is used to drive the Huntington mills, but has to be paid for.

Petroleum Fields of the United States and Canada.—Mr. B. Redwood describes the method and cost of boring for petroleum in the various petroleum districts. In the Washington field, Pennsylvania, the wells are much deeper than in the older fields, and are invariably torpedoed, often more than once, the charge in some cases being 80 quarts of nitro-glycerine. Nearly all the wells are flowing wells, and should yield a 100 barrels a day in order to pay, owing to the expense of boring, which averages 7 to 8 shillings a foot as against 2 shillings in the Bradford district. Besides Pennsylvania, New York and Ohio, the States of West Virginia, Kentucky, and Tennessee also produce oil in large quantities, and it is also found in many other States. In California there are also one or two small fields. In one, tunnels were driven into the hill-side, but the yield was small; as a general rule, the wells have to be pumped. The Canadian petroleum industry dates from 1857; the principal field now is Petrolia, sixteen miles south-west of the outlet of Lake Huron and Bothwell, thirty-five miles distant. There are now 2,500 productive wells, with an aggregate production of 70,000 barrels per annum. The wells at Oil Springs, Petrolia, are about 375 feet deep, and are torpedoed with 8 to 10 quarts of nitro-glycerine.

Salt Mining in Canada.—Nearly all the salt produced in the Dominion is manufactured in Ontario, adjacent to Lake Huron, the largest number of working wells being situated in the County of Huron, whilst a few are being operated outside of this area in the counties of Lambton on the south, Bruce on the north, and Perth on the west. There were nineteen wells working during 1886, six of which are located at Godrich, where the salt was originally discovered. The remainder of the works are located at the following places:—Dublin, Seaford, Clinton, Hensall, Exeter, Blyth, Kinardine, Brussels, Cartwright, Glaston and Wingham. Numerous other wells have been bored and blocks operated besides these, but are not now working, owing to the depression in this industry. The first discovery was made at Godrich, in 1865, in a boring made there in search for petroleum. In 1876 Mr. Attrill put down a drain and drill-hole near Godrich, which came upon the first salt bed at a depth of 997 feet from the surface, and in a depth of 520 feet below this the hole penetrated six salt beds aggregating 126 feet in thickness, the thinnest bed measuring six feet and the thickest thirty-five feet wide. The salt occurs at a greater depth in passing eastwards from the lake shore, a boring at Seaford, about thirty miles south-east from Godrich, having struck salt at a depth of 1,035 feet.

The Largest Smeltery on the Continent.—The immense smelting works at Omaha, Nebraska, are the largest of their kind in America and as the erection of works of a similar nature are at present, under contemplation in various parts of our Dominion, a brief sketch of these may prove of interest and value to our readers at the present time:—The Omaha works were a small establishment originally started by Messrs. A. L. King, C. H. Downs, C. W. Mead

and General W. W. Lowe in 1869, which has gradually advanced with the city until at the present time, the works have far outstripped in growth and magnitude, all other establishments of the kind in America, and in conjunction with the Grant Smelting works of Denver, (which are owned by the Omaha firm,) the company can lay claim to the largest smelting establishment in the world. Whilst the Denver establishment, however, is confined to smelting operations only, the Omaha shops both smelt and refine. The large quantities of ore which daily find their way into Omaha for treatment are principally brought from Montana, Idaho, Colorado, Utah, Dakota, and Arizona. Base bullion is also shipped to the works on a large scale from the different smelting works throughout the country, for the purpose of refinement. About 40 per cent of this latter substance comes from the Denver branch of the firm. An idea of the magnitude of the company's operations may be gathered from the fact that they employ over 500 men and have already \$3,000,000 invested in the enterprise. The annual business done by the corporation, too, is in the like proportion. During the last year upwards of 315,000,000 has been "turned over." The company receives on an average 200 carloads of ore per month, and over 200 cars arrive monthly laden with base bullion consigned to them. When the ore or bullion arrives at the works the first thing done is to make an assay, from which the company is enabled to measure the amount of lead, silver, gold, antimony, or any other metals they will severally yield per ton, and so accurate has this process become that by treatment of a comparatively small portion the furnaces will disclose, almost to a dollar, the net value of a large shipment. Cash is then paid according to the prices for the time being ruling in New York. The ore is now treated on the larger scale. As in the assay this is effected through the medium of reverberatory furnaces so constructed that by means of a dome, or low arched roof, the flame in passing through the fire chamber, is reflected or reverberated in the ore. Whilst undergoing this fiery ordeal the metals are separated and the attendant at the furnace secures them in the form of base bullion or unrefined metal. Lead, silver, gold and antimony are thus extracted from the same ore. The bullion is then moulded into bricks, which are in due course sent to the refinery. Here they are again placed in reverberatory furnaces and all existing dross and foreign substances are extracted until nothing remains but the pure metal. This also is moulded into bricks. The gold brick made by the company weighs 250 ounces and is worth \$5,000. Silver is turned out in \$1,000 ounce bricks which are worth about \$1,000 each. This process of reducing the ore is, of necessity, of the most technical nature, and a thorough knowledge of metallurgy and chemistry is necessary for a proper appreciation of its intricacies. To enter into an elaborate dissertation on the inner workings of the process, however, would be outside the scope of this article. The greater portion of the gold and silver is forwarded to the United States mints, at New Orleans and Philadelphia, where it is purchased by the government. The refined silver sells at prices ranging from 94 cents to \$1.15 per ounce, whilst gold brings the uniform price of \$20.67 per ounce. For the half year ending July 1, of the present year, the works have turned on 4,583,264 ounces of silver and 40,640 of gold, whilst they have placed the enormous amount of 28,514,000 pounds of lead on the market during the same period. For the last named

metal the ruling price is about 4½ cents per pound. The company is also extensively engaged in the manufacture of blue-stone, of which they turn out sixty barrels per day. This substance is principally employed in the working of electric batteries. The works cover a great area of ground and comprise a series of solidly constructed brick buildings in which the seething flames of upwards of one hundred furnaces are constantly at work.

The Decline of Natural Gas in America.—In a paper read at Cleveland, Mr. N. B. Wood expressed the opinion that the supply of natural gas is rapidly being exhausted. Either gas is being formed, or the quantity being wasted has been over estimated, or the supply must soon be exhausted. The two latter are, perhaps, the facts in the case, but the last is the more important. Immense gas wells will cease to be known in a few years, and those districts which are now the most productive will be soonest exhausted. Already there are reports of the failure of noted wells; and noted districts are becoming unproductive. Careful and conservative engineers are advocating laws regulating the sinking of wells and the more economical use of gas. At Erie, where gas has been used for a great many years, the supply has fallen off to such an extent that it is now being piped into the city from a distance. Credible information states that since so many gas wells have been sunk at Findlay the quantity of gas has perceptibly diminished. The only exception is East Liverpool, where gas has been used in the potteries for twenty years without sign of exhaustion.

Crude Phosphate as a Fertilizer.—Our readers who have been following the discussion in these pages on the question of the utility of crude phosphate as a fertilizer, will read with interest the remarks of Mr. Andrew H. Ward, Boston, on this subject. Mr. Ward in an able article recently contributed to the *Eastern Farmer*, says:—

"Of all the crops raised, corn requires the largest amount of phosphoric acid, 100 bushels with stover abstracting from the soil sixty-four pounds, while potatoes and tobacco take from the soil a large amount of potash, 600 bushels of potatoes abstracting 219 pounds. It is assumed that the soil contains enough of the other mineral elements for the growth of crops, for we are constantly informed that all that is required to add to the soil is nitrogen, phosphoric acid and potash, and latterly nitrogen is not held in as high esteem as it was, particularly in the growing of corn. The experiments in Connecticut on this crop show the nitrogen increased the crop enough to pay the cost thirteen trials out of twenty-six.

"The pecuniary loss rose and fell with the amount of nitrogen used. With mineral fertilizers alone the crop gathered some sixty-five pounds of nitrogen per acre. As sixty-four pounds of phosphoric acid can be furnished in fine ground phosphate of lime at \$1.28, and 219 pounds of actual potash in muriate of potash for \$7.66, both combined costing \$8.94 to furnish the mineral elements deemed necessary to supply to the soil the amount abstracted from it by 100 bushels of corn or 600 bushels of potatoes. It does not seem to be economy, good judgment, or profitable, to let our lands run down and go to waste, and it will not be long before agriculture will be more thought of in this section, and more attention given to it.

"The one great want has been manure. Our stock has decreased, our lands have not been kept in condition for the want of manure and a bad system of tillage, consequently farming has not, as a general thing, been so profitable as to induce those who could get out to remain in, or induce those who were out to come in, but our farms have now got to a price that should induce purchasers, and by the application of artificial manures they can be made to grow paying crops at once.

"With fine-ground raw phosphates as the basis of operations, we can now obtain complete manures for any culture, made according to any formula and containing in a readily assimilated form all the ingredients called for."

Wire Rope Haulage and its Application to Mining.

By Frank C. Roberts, C.E., Philadelphia, Pa.

Continued from January Issue.

II. INCLINED PLANES.

It is often found economical and convenient, when sinking a shaft, to incline the line of descent at an angle to the vertical, so that the material shall be hoisted on tracks running on track systems. Power is supplied by hoisting engines, and for this reason these planes are denominated engine planes. Again, in many localities, especially in the bituminous coal region, the adits to the mine are at a considerable elevation above the overground system of transportation, requiring the lowering of the mining-product from the mine to convenient points for shipment. This is usually secured by means of an inclined plane termed a gravity plane, and operated by the gravity of the descending load. In either type of inclined plane the line of descent may be curved or have variable grades, the only requisite being that the fall shall be in one direction and that the grade shall be sufficient to enable the loaded or empty car to descend by gravity.

Fig. 8 represents the arrangements of tracks

most economical in construction for either system, while it also has the merit of a capacity equal to that of any other. The section C is termed the *parting*, its purpose being to enable the descending and ascending cars to pass each other. For this reason it is placed in the centre of the inclined plane. The distinguishing feature of this road-bed is that above the parting we have three lines of rails, while below we have but two. This plan necessitates the use of an automatic switch at the lower point (A) of the parting (see Fig. 11, which is, however, reversed in position, as compared with Fig. 8). This simple arrangement consists in two iron-bound timbers pivoted at one end and moving over the rails. In the illustration the switch is arranged so that the loaded car going up will take the track S while the wheels of the descending car on M, in passing A, will shift the switch to the position shown in dotted lines. When the next loaded car ascends it passes into the parting on the track M. This arrangement of road-bed has been in use with great success, and the general verdict of the mining community is that it answers, to all intents and purposes, the ends sought by more expensive devices. To avoid the necessity of the automatic switch at the lower end of the parting, the system illustrated in Fig. 9 has been devised. Its operation will be readily

understood from the figure. The double-track incline, Fig. 10, is frequently employed, but the extra expense of broader road-bed renders it less common among mines of ordinary capacity. Where the output is very large, however, its advantages are evident.

An important detail in connection with all inclined planes is the arrangement of switches placed at the mine-end of the plane. Fig. 12 shows a simple and efficient device. The switch consists of three pivoted tongues, which govern, according to their position, the disposition of the cars. In the gravity system the loaded cars descend alternately by the tracks P and Q, and the empty cars always pass to N. In the engine-incline the loaded cars ascend alternately by the same tracks, the loaded cars here passing to N. As the switches are placed, the empty cars, in the gravity-plane, will pass to N and the loaded cars advancing by M will pass to Q, while the empty car returning by P will open E and close D. A being closed, the empty car passes again to N, while the next loaded car advancing by M, descends the plane by P. Except that the tongue A has to be kept closed by a tender, the switch is automatic. The same is true of the operation of the switch at the head of an engine-plane, except that the loaded instead of the empty cars pass to N.

In all inclined planes it is necessary to employ some form of safety-device to provide against accidents arising from the breakage of the hoisting-rope. Much attention has been directed to these safety-devices, but in all designs the operation is dependent upon one of two principles—either to stop the cars or to guide them off the incline. The chief objection to these devices is that they are all controlled by a man stationed at the head of the plane. It is to be regretted that there exists no simple and inexpensive method whereby the safety arrangements are rendered automatic, as in the vertical hoists.

Fig. 13 represents a simple device for stopping runaway cars. Two heavy iron-bound timbers, A, are pivoted near their centres at the side of the outer rails, as shown. The arrangement of counter-weights is such that when it becomes necessary to bring the timbers into action the pin P, forming the connection between the two timbers, is withdrawn by pulling the wire S, connecting with the head of the plane. As a result, the release of the counter-weights W W throws the timbers over the rails, as indicated by the dotted lines. A number of these devices are placed along the incline, all being connected to the single wire leading to the head of the plane. This method is somewhat inferior to the one illustrated in Fig. 14. Owing to the uncertainty of stopping the cars when descending at a great velocity, their tendency being to jump the timbers and continue their course. The device shown in Fig. 14 consists in side-switching the car. This is performed by the tongues D, E, F and G, actuated by a system of bell-cranks and weights, as shown. The switch is held open by the pin P, and when this is withdrawn by means of the wire S, the switches are closed by the action of the counterweights W. This device, although resulting in the partial destruction of the car, renders the danger to life and valuable property considerably less than the preceding arrangement. What is known as the *dead-fall* is employed in some mines. A heavy timber, guided in an upright frame, is placed over the track, and, when released, falls over the rails.

In all applications of wire rope except vertical hoists, it is necessary to support the rope at

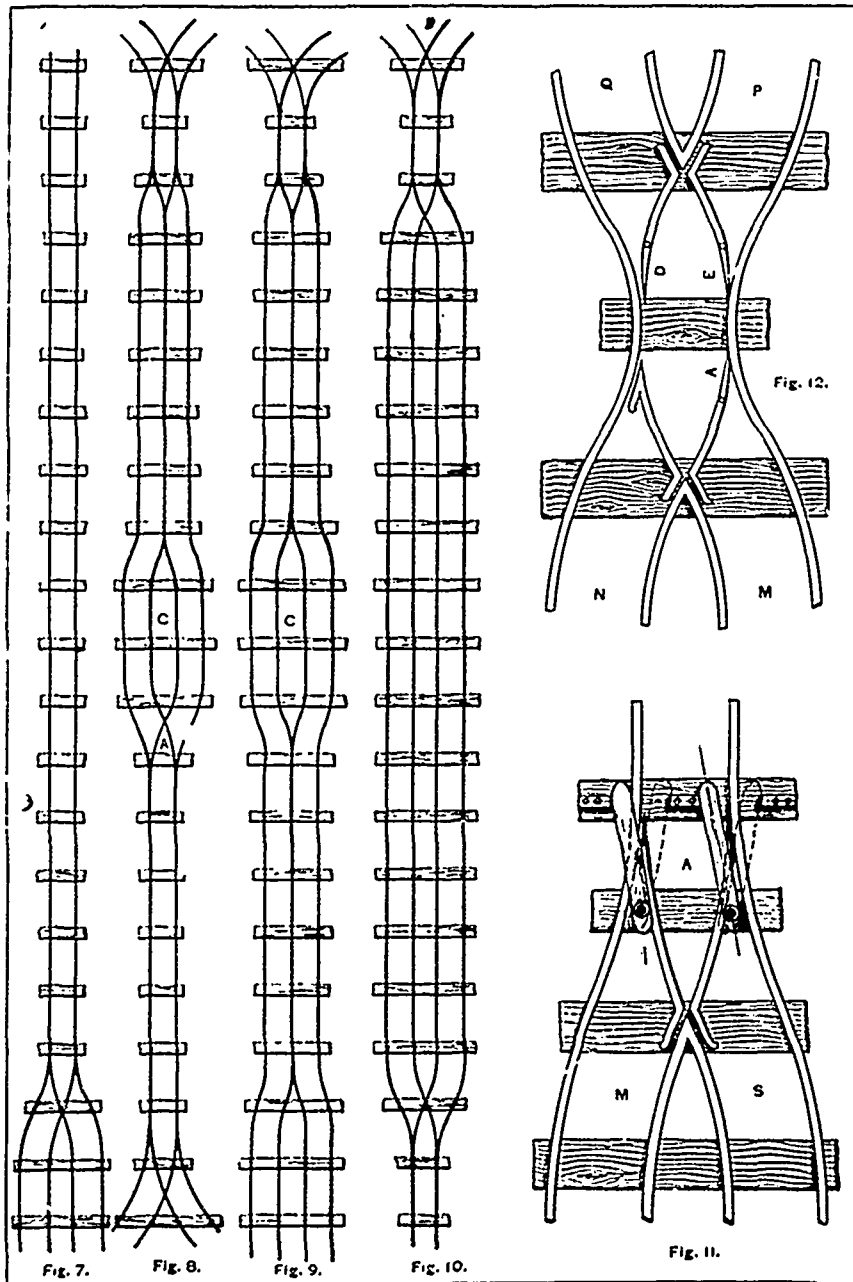

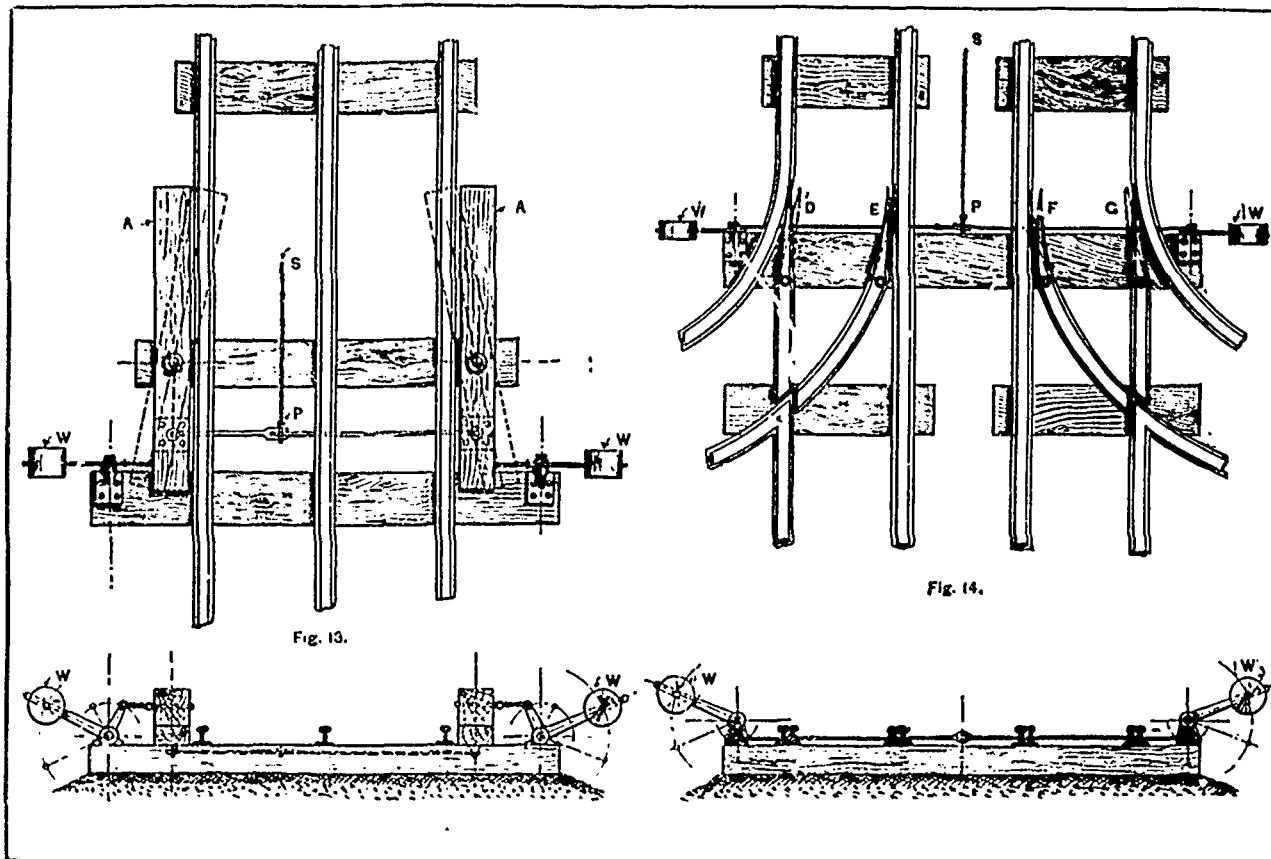

frequent intervals by rollers, otherwise the rope would drag upon the ground and increase the power absorbed by friction, as well as cause the rope to wear out rapidly. A cheap and efficient roller (Figs. 15 and 16) is constructed of gum-wood, of as large a diameter as is consistent with the location, and from 12 to 24 inches in length. The axles are 1 inch or 1½ inch round iron, running in simple cast-iron bearings. The much-discussed question of comparative detrimental effect upon wire rope of wooden and iron rollers is doubtless to be answered in favour of the former; but whatever the advantage may be, it is so slight that it is hardly worth consideration, since, in a properly-constructed plane, the rope simply rests upon the rollers.

Curves.—The difficulty of passing curves is solved by two efficient and simple methods. Figs. 17 and 18 illustrate one device, whereby the rope is taken round a curve by means of a series of wheels about 24 inches in diameter, placed outside the track. The car, in turning a curve, brings the rope between the rails; but, after passing, the rope is guided back into the

groove of the wheels by the timbers C, placed in front of each pulley. The guide-wheels are sometimes placed, as shown at A, Figs. 19 and 20, between the rails and a few inches to one side of the centre line. These wheels are, of necessity, smaller than the preceding, and are held in a slightly-inclined position to the horizontal by the bearings E, Fig. 20. The rope is

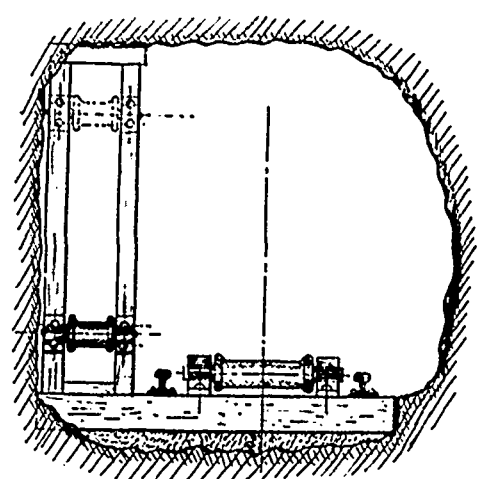

FIG. 15.



FIG. 16.

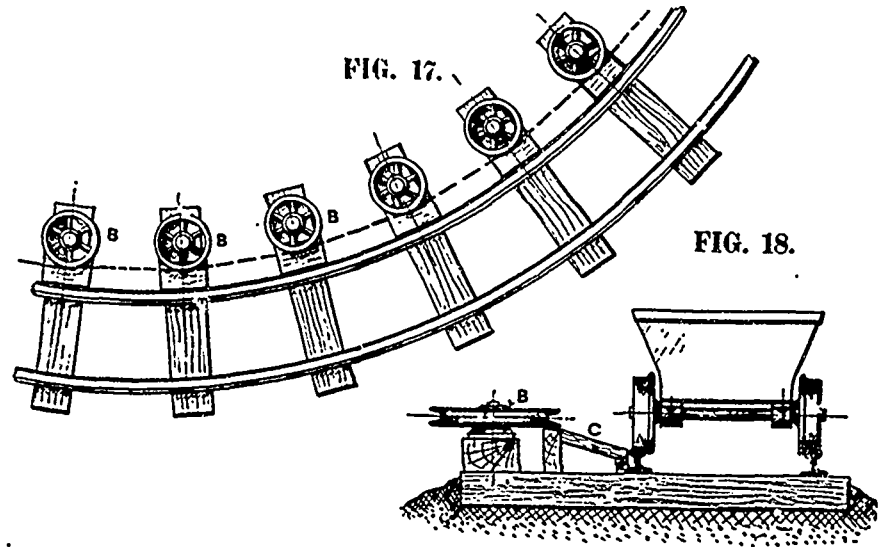

FIG. 17.

FIG. 18.

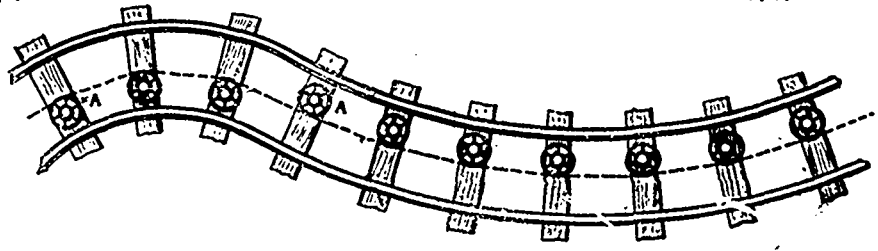

FIG. 19.

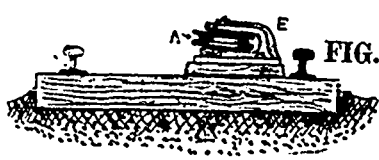

FIG. 20.

attached to the car at the same level as the grooves of the wheels. In passing a curve the rope is drawn to the centre of the track, and falls back into the grooves when the curve has been rounded. Either of these systems may be employed with advantage, the determination of the more efficient being a matter of location.

(To be continued.)

American Institute of Mining Engineers.

The fiftieth meeting of this Institute, being the eighteenth annual meeting, will be held at Boston, Mass., beginning on Tuesday evening, 21st instant. We are indebted to Dr. Raymond, Secretary of the Institute, for the following information regarding the proceedings:—

Tuesday Evening February 21.—Opening session at 8 p.m. at Hotel Brunswick, to be called to order by General Francis A. Walker, President of the Massachusetts Institute of Technology. After the addresses of welcome and reply, there will be, at 10 p.m., a supper, at which visiting members and friends will be the guests of the local committee.

Wednesday, February 22.—Sessions morning and afternoon, at the Institute of Technology. In the evening, a subscription dinner at Hotel Brunswick.

Thursday, February 23.—Omnibuses will leave Hotel Brunswick at 8.20 a.m. for Fitchburg depot. Special train leaves depot at 8.55 a.m., arriving at 10.25 a.m. at Fitchburg, where Simonds' rolling machinery for rolling car axles, conical and spherical shot and various regular shapes, Simonds' saw factory, and (for those who desire it) the works of the Putnam Machine Company, and the Fitchburg Steam Engine Company, will be visited. The party will be entertained at luncheon by Mr. Simonds, and the train will leave Fitchburg about 1.15 p.m., arriving about 2.50 p.m. at Waltham, where the Waltham Watch Works will be visited. Leaving Waltham about 4.30 p.m. the party will reach Boston about 4.45 p.m. Those who wish to inspect the famous testing-machine at Watertown can easily arrange to include this excursion by omitting the stop at Waltham, in which case they will arrive in Boston at 5.08 or 5.38 p.m.

On Thursday evening there will be a session at the Institute of Technology.

Friday, February 24.—Morning and afternoon will be devoted to minor excursions and visits, of which about twenty have been planned, a guide being provided for each. Opportunity will be given to members to signify their choice among these. The more important of those thus far arranged are to the following places:—

The Sewage Pumping Engine (visit under the auspices of the Boston Society of Civil Engineers); the Harvard University Museums and Laboratories; Cotton Mills at Lowell; the Clapp Griffiths Works; the Laboratories of the Massachusetts Institute of Technology; the Norway Iron Works; the Tyler Tube Mill, the Ames Shovel Works at North Easton, the Mitis Works at Newsonset; the Boston Art Museum.

On Friday evening the closing session will be held at the Institute of Technology. At this session the Annual Report of the Council will be presented, and the result of the election of officers will be announced.

Members desiring to present papers at this meeting will notify Dr. Raymond as soon as possible, forwarding either the full manuscript of papers or abstracts, with such information as to nature, length, amount of illustrative drawings, etc., as will permit a judgment as to their

acceptability. The following papers have been announced up to the present time:

The Formation of Fissure Veins, by S. F. Emmons, Washington, D. C.

Spirally Welded Tubing, by J. C. Bayles, New York City.

The Theory of Jigging, by H. S. Munroe, New York City.

Notes on the Topography and Geology of the Cerro de Pasco, Peru, by A. D. Hodges, Jr., Boston, Mass.

The La Plata del Libano Mines, Columbia, by Willard Ide Pierce, New York City.

Western Kentucky Coals and Cokes, by Joseph H. Allen, Mannington, Ky.

Steel Rails, by Frederick A. Delano, Chicago, Ill.

The Thermal Properties of Slags, by H. M. Howe, Boston, Mass.

The Russell Process in Its Practical Application and Economical Results, by Ellsworth Dagget, Salt Lake City, Utah.

Recent Developments in the Open Hearth Process, by Alfred E. Hunt, Pittsburgh, Pa.

The Husgafvel Furnace for Making Malleable Iron, by F. Lynwood Garrison, Philadelphia, Pa.

An Improved System of Water Supply for Hydraulic Mining, by H. D. Pearsall, London, Eng.

The Determination of Silica in Cinder, by R. H. Lee, Lewiston, Pa.

A Method for the Estimation of Manganese in Steel, by Frank Julian, Chicago, Ill.

A Glossary of Furnace Terms, in English, French and German, by Thomas Egleston, New York City.

Systems of Mining in Large Bodies of Soft Ore, by R. P. Rothwell, New York City.

Prominent Sources of Iron Ore Supply, by John Birkinbine, Philadelphia, Pa.

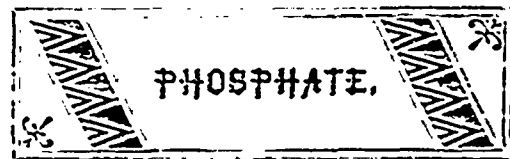

In General.

Messrs. Couper, McCarnie & Co., London, Eng., in their Buyers Circular of the 16th ulto., state: "MINERAL PHOSPHATES.—Canadian.—The shipments for 1887 show that 20,000 tons were exported to United Kingdom and Continent during the past season, which maintains the average of recent years. South Carolina Phosphates are held firmer, but the price is not yet sufficiently remunerative to encourage Raisers to sell any large quantities for this market. Somme Phosphate.—The only obstacle to a general acceptance of the Syndicate terms has been a few resales of speculative parcels; in spite of this, a fair business has passed at the rise. Belgian Phosphates dull, and little doing. Sulfur freights are getting scarce, and will tend to increase the quotations slightly for this material. There is not much doing in Cambridge Coprolites, and to effect business Raisers have been obliged to accept a low price.

Since our last issue, we have received communications from prominent shippers asking us to give an unqualified denial to the statement that Canadian ore on reaching Great Britain is frequently handled by interested parties, who grade the ore below its true quality, and thus force the miners to take any price buyers on the other side may offer.

Du Lievre.

Mr. C. C. Hoyer Millar, of Messrs. Millar & Co., Montreal, a partner in the well known firm of phosphate brokers, Messrs. Couper, McCarnie & Co., London, England, and a director of the Canadian Phosphate Company, Ltd. (the company which has been formed to take over the phosphate lands of the Union Phosphate Mining and Land Company, at West Portland), accompanied by Mr. O. M. Harris, his representative in Montreal, visited the company's mines during the last week in January for the purpose of seeing what new machinery, tramways, buildings, etc., would be required for the future working of the new company's mine and augmentation of the output. Mr. Millar was much pleased with the present appearance of the workings, and entertains great hopes for the future of this large undertaking. We learn that a tramway from the mines to the river will be laid early in the spring, and that considerable extra machinery is being purchased, and also that more cobbing houses, tenements, etc., are to be built almost immediately. The number of employees will also be increased.

The rumour which gained currency in several of the Ottawa papers that Mr. Wm. Mackintosh had been appointed superintendent of the Canadian Phosphate Company's Mines has no foundation in fact. Captain J. E. Smith, who conducted operations with so much acceptance to the Union Company, will retain the position with the new corporation.

We are informed that the Commercial Union Phosphate Company has been incorporated in the State of Wisconsin with a capital of one hundred thousand dollars, to operate phosphate lands in the township of Portland West. Mr. J. A. McIntosh, of Milwaukee, is one of the promoters, and among other gentlemen mentioned are Mr. James L. Gates, lumberman, Mr. James Kneeland, gentleman; Messrs. Ames and Avery, Real Estate Agents, Mr. Henry Herinan, Real Estate, all of Milwaukee; and Mr. R. G. Peters of Munistee, Mich., the principal owner of the well known Beaver silver mine near Port Arthur. Operations will be commenced early in the spring. The capital stock is divided into one hundred shares of a par value of \$100.00 each.

A correspondent to *The Daily Review*, Milwaukee, writes:—

"I am informed that some of Milwaukee's leading financial gentlemen are interested in this company. When such men as James Kneeland, R. G. Peters, Manistee, James L. Gates, Messrs. Ames and Avery, and other gentlemen of very high financial and commercial standing are interested in this company, there can be but one opinion as to the success of the Commercial Union Phosphate Company, and that is, financial prosperity to all those interested and a boon of great value to the agricultural community, who require so much of this great fertilizer to restore the worn out fields to their original producing capacity. Phosphate, in its natural state, ground, is one of the finest fertilizers in the world for house plants and garden vegetables, being odorless and adds a fine flavor to all kinds of plants. It is stated by the very highest scientific authority that every ton of wheat absorbs 16 pounds of phosphate from the soil. In this case how much does the great agricultural districts and wheat growing countries require of this—the greatest gift of nature's provider to replace what is every year absorbed from the soil. It is unquestionable that nothing has yet ever been discovered to equal apatite or phosphate for fertilizing purposes."

The Du Lievre Milling and Manufacturing Company, who, up to the present time, have only been running their grinding mill at Scarborough (Bassin du Lievre) are making arrange-

ments to push the development of their mining property, and as soon as spring opens a large gang of miners will commence work at the Lillie mine. This will ensure a supply of rock for grinding. When last prospected, a rich vein was opened up showing a large quantity of high grade ore and the management are confident that by pushing mining operations vigorously, profitable results will accrue. We are informed that everything is now ready for extensive operations: boarding house, cook house, smith's shop, steam plant and machinery, all being in position ready to start work. With ample capital this Company propose to mine, grind, and market their own product, for which contracts for large supplies have already been made. A portion of the ore will be treated by Mr. Shirley's new process, by which the crude rock is rendered soluble.

The contractors are making rapid progress with the construction of the Lock and Dam at Little Rapids.

A night shift has been put on at the North Star. The blacksmith shop at this mine was burned down last month.

The Central Lake mine is turning out well, and gives promise of a large output when navigation opens.

The Emerald and North Star are turning out about their usual winter's output, and large shipments will be made during the coming season.

Latest advices from the Lievre announce that the staff at the Little Rapids mines will be considerably augmented in a few weeks. During the winter many valuable bodies of ore have been uncovered, and arrangements are being made to prosecute the work on a more extensive scale than heretofore. The shipment last year, with a comparatively small number of men, figured over 700 tons, averaging from \$1 to \$5 $\frac{1}{2}$; there is every indication that this high standard will be maintained during the coming season.

Templeton District.

Mr. Trimble, of Montreal, managing director of the Templeton and Blanche River Company, was out at the mines during the month completing arrangements for the immediate erection of steam working plant and machinery. Everything is being done conducive to a large output as soon as the shipping season opens.

Mr. R. Blackburn states that some 60 men are working at his celebrated mines, and that the quantity and quality of the ore is steadily improving. Three hundred tons have been hauled to the river, and the sheds at the mines are full. The present output is very largely sugar phosphate.

Kingston District.

Captain Boyd Smith, of Washington, D.C., proprietor of the Blessington Mines, sailed per s.s. Aurania for London on 11th instant. He will be on the Continent some time, and hopes to secure a large number of miners and their families to settle on his properties in Canada.

With a largely increased force, skilled labour, and improved machinery, Superintendent Harris will produce a large output from these mines during the ensuing season.

Phosphate land in Sydenham is attracting

more attention than ever, and five hundred acres which Captain Boyd Smith, of Washington, bought for \$7,000 a few years ago, is held now at a quarter of a million.



Nova Scotia.

All the Nova Scotia collieries are greatly hampered through scarcity of rolling stock on the Intercolonial railway, caused in part by the snow blockades, on the northern division, and increase of business.

Owing to these causes, the shipments from the Springhill mines for last month only amounted to 26,228 tons of 2,240 lbs. The output under ordinary circumstances would have been 29,500 gross tons.

A trial test of nine tons of quartz taken from a 5 inch lead on the Cochrane Hill property yielded 18 ozs. of gold.

The 15-stamp mill is kept running night and day, and about 45 men are employed at the Cowan mine, Kemptville.

The International Coal Company held its annual meeting at Montreal on 15th instant. The following directors were elected:—Sir D. A. Smith, M.P., Messrs. Hugh McLennan, John McLennan, A. Kingman and T. B. Brown. At a subsequent meeting of the directors Mr. H. McLennan was elected president and Mr. T. B. Brown secretary-treasurer.

Quebec.

At the Villeneuve Mica and Mining Company's mines, one of the buildings used as a store, sleeping house, and other purposes, has been burned to the ground since our last. The fire originated through an overheated stove-pipe: the loss is covered by insurance.

The annual meeting of the company was held in Ottawa on Wednesday, the 14th inst., when the following were appointed officers for the ensuing year:—President, S. P. Franchot; Secretary-Treasurer, G. Von Rehn; Directors, B. H. Buxton, E. Hodges and F. Gorman. It was decided that all meetings of the company will henceforward be held at Buckingham.

The company entertain hopes of an extended business during the coming year. The output continues to fulfil every expectation both as to quantity and quality. A crystal was taken out last month which weighed a little over 160 lbs.

Mr. Thomas Cosgrove, Hathaway, was in the city lately with several very likely specimens of phosphate, asbestos and other minerals taken from his property.

We are informed that the Boston Asbestos Company have sold all their output for the coming year at a rate not less than \$75.00 per ton.

The Scottish Canadian Asbestos Company are erecting a crusher and other plant which will do away with the slow and expensive mode of hand cobbing hitherto employed. It is estimated that the new machinery will cost over \$10,000.

Ontario.

The new opening made recently on the Richardson mine, near the old pocket, looks well, but as yet no depth has been obtained, sufficiently to prove a true vein.

Capt. Symonds, Superintendent of the Bristol Iron Co's mines, gave us a call during this month. He states that the calcining furnaces recently erected by Messrs. Taylor and Langdon are not giving the satisfaction promised, and roasting has temporarily suspended. Captain Symonds leaves for New Jersey, in a day or two, on a visit to the patentees of the furnaces and hopes to be able to have the defect remedied and work resumed at an early date.

There are at present 80 men on his pay roll. 20,000 tons of ore are on the dump, of which 6,000 has already been calcined. Mining will be conducted with vigor as soon as the snow leaves the ground.

A general meeting of the Lake Superior Copper Company (Limited) was held in London, England, on the 5th instant. For the purpose of enabling the company to resume mining operations, the directors are authorized to issue the remainder of the unallotted ordinary shares of the company, or such portion of them as they might deem necessary, at a discount of 75 per cent., and upon such terms as they may think fit. The chairman explained, however, that within two days a legal difficulty had arisen which rendered the directors unable to submit the resolution, it having been stated on high legal authority that directors had no power to issue shares at a discount. The activity in the copper market and the rise in the price of copper seemed to afford the company the opportunity for which it had long waited, of beginning their work again on a considerable scale. At the time the work was stopped, the prospects were all in favor of the mine turning out an exceedingly good one. The stuff had improved in quality from the surface to the point they reached. To work it the shareholders would have to make some sacrifice—they would have to take shares with some slight liability in order to be able to get the outside public to come in. The expense of unwatering the mine would be £400 or £500, but they must have two or three months' capital in hand—to work the mine they ought to have £10,000. Resolutions were passed requesting the directors to take immediate steps for relieving the shareholders from any liability at present attaching, or supposed to be attached, to the shares at present issued, and for obtaining capital for the future working of the mine in such a manner—either by the sale of the property or otherwise—as may be deemed best.

Some strong veins of white mica are being opened up at Mr. D. G. MacMartin's mines at Pike Lake. As development proceeds the crystals are found to increase in size and to be more regularly formed. Several hundred pounds of merchantable mica have already been taken out and await transportation. The output and quality improves daily, and the product of this mine will be sufficient to furnish a large portion of the demand for Canadian consumption.

The vein being developed at the Tough and Stobie gold property continues to improve as depth is attained.

Mr. W. B. McAllister is boring for oil at Pembroke. A depth of 100 feet has been attained, and favorable indications are reported.

Port Arthur District.

The BADGER MINE is rapidly coming to the front as a favorite. Those who inspected the mine last week report much of the ore extracted as equal to the best output of the celebrated Beaver mine. It is the intention of the owners to have fifty men at work as soon as the accommodation is complete and the mine sufficiently advanced for their profitable employment, which will probably be about May next.

The BEAVER MINE is working steadily along, producing silver in quantity. A number of silver bricks were brought into town for shipment last week. Everything around this mine indicates that men of wealth, who believe thoroughly in their prize, are working it to the best of their ability.

SILVER MOUNTAIN has apparently settled down into a comfortable existence. Although nothing astonishing in the way of valuable silver deposits are reported, it is evident from the extreme caution of the managers in keeping their operations to themselves, that they intend somebody to benefit thereby. It is stated that parties, not a hundred miles from Port Arthur, cabled for a number of shares to Liverpool, but were answered that all were sold and none in the market.

The CROWN POINT Mine, immediately adjacent to Silver Mountain, develops slowly with a very small force. More accommodation, however, for man and beast is being provided by the owners, who are buying up adjacent land suitable for building purposes.

The CARIBOU MINE under Capt. Rothwell is developing richly and gives great satisfaction to the owners, who are also preparing for work on a larger scale.

MINING LOCATION R. 230 is beginning to fall into hands worthy of such a promising prospect. Ore quite as rich as the best Silver Mountain or Beaver Mine specimens have been taken out of this mine. The Marquis of Huntley, who visited this district last summer, is reported to have control of nearly, if not quite all of this prospect, and will erect a stamp mill next season should the output continue satisfactory.

THE PORCUPINE Mine is again doing a little, and it is reported will shortly become the property of a syndicate able to do it justice.

The Ontario Government are preparing early for the increased traffic into the mining region by building an almost entirely new bridge across the Kaministiquia River on the Government road to the mines.

What is wanted very badly, however, is a railroad, and it is to be hoped that the Ontario

FOR SALE.

Asbestos Mines.

On Lots 27, 28 and 29, in Range A, of Coltraine, Megantic County, P. Q.

300 ACRES,

One Mile from Quebec Central Railway.

Free from Reserves or Royalties.

James Reed,

Reedsdale, Megantic, P. Q.

Government will realize that they have the right and that it is their bounden duty to assist such an enterprise. Two schemes are now being pressed on the notice of the Government—the first being a road direct from Port Arthur to connect with the Duluth and Iron Range Extension, of which about ten miles have already been built from Port Arthur westward. The other is practically the same as the former for the first fifty miles or more, and then runs direct for Winnipeg to take its share of the immense grain trade which is now suffering from lack of sufficient accommodation. Both schemes have excellent backing, and only want the usual Provincial legislation and bonus to start them vigorously into life.

The topographical survey of the great lakes in this interesting region is progressing favorably under Messrs Russell and Macdougall, who will remain in the field as long as the ice holds good.

A great deal of harm is being done to the Thunder Bay district by the extravagant reports given in the Winnipeg papers and reported as emanating from ex-manager Kirkland of the Beaver mine. He is reported to have said that he had sold one-half of his interest in that mine for \$600,000 and could not manage to get it back again for \$700,000. This is rubbish pure and simple, as we have it on excellent authority that Mr. Kirkland neither has or had any interest whatever.

The district is all right and does not need any "booming."

Manitoba and North-West Territories.

The severe weather has greatly retarded work at the mines of the Canadian Anthracite Coal Company, at Banff, and about two hundred men have been idle for several weeks. Latest reports, however, state that the weather has modified, and that operations have been resumed.

The Edmonton *Bulletin* states:—Five coal mines are being operated to keep this town and immediately vicinity supplied with fuel, all within what might be called the corporation limits—W. Humberstone's, D. Ross', and Frank Hall's on the north side, and J. Walter's and E. Caverhill's on the south side.

British Columbia.

At a meeting held lately at Nanaimo, it was decided to organize a Mining Institute for the district.

The explosion which occurred about nine o'clock on the morning of 24th ultimo, in No. 5 shaft of the Wellington Colliery, owned and operated by R. Dunsmuir & Sons, has proved to be a more serious disaster than was at first anticipated. About two hundred men, whites and Chinese, were in the mine at the time, and latest reports show that at least ninety of these perished. As the shaft timbers were destroyed and cages could not be used, a pulley and rope were immediately prepared. A temporary cage was made and lowered to a considerable depth. Several of the imprisoned miners reached it and were hauled up. In the last level, where it is believed the explosion occurred, 25 bodies were found in a heap, some of them terribly disfigured. Messrs. Dunsmuir's loss is estimated at between \$25,000 and \$30,000.

The *Colonist* has received a private despatch from Nanaimo announcing that the East Wellington Colliery, operated by W. S. Chandler, has been shut down. No reason is assigned.

Advices from the Treadwell mines near Juneau, Alaska, state that on New Year's day, the powder magazine containing 2,000 pounds of blasting powder exploded with terrific force, blowing the building into atoms and doing much damage to surrounding property. Fortunately the miners were all working on the ledge beyond the reach of the explosion, and only one life was lost. A workman in the mill, oiling shafts some distance above ground, was thrown down and severely injured. The explosion was felt with great force in Juneau, two and a half miles away.

The Alaska *Free-Press* reports that negotiations are in progress with English capitalists for the purchase on the Bears Nest claims on Douglas Island. One million and quarter dollars are wanted.

A number of miners are now preparing to start into the Yukon, crossing the lakes and making the journey down the river on the ice. They expect to reach the mouth of Forty-Mile creek about the middle of April, and get up that stream to their claims by the time the ice breaks up, which is from the 1st to the 15th of May. By being on the ground at that time they can get in about four months work before their return next fall.

"SHE."

Improbabilities Sometimes Become Realities—A True Woman's Fidelity.

Several works bearing unique titles, written in fascinating style, and giving evidence of wonderful imaginative power have lately been received by the reading public with much popularity and pleasure.

Perhaps the most striking of them is the book bearing the odd title of "She." In this the author has fairly outdone himself in his popular line. Ayesha and her beloved Kallikrates are unique characters in fiction. Ayesha, the heroine, is a beautiful creature who tasted of the essence of nature's forces at the fountain head, and became immortal.

Her patient waiting for the coming of Kallikrates, the beloved of her youth, whose individuality was maintained through centuries, though the change called death regularly occurred, only to be followed by rebirth, is a fine illustration of woman's fidelity.

The closing scene, when she conducts Kallikrates to the very centre of the earth, the birthplace of all life, in order that he may taste of immortality, is a fit climax to the fine creation.

The question naturally suggested by this strikingly original story is whether there is not somewhere in nature, a potent force whereby life may at least be temporarily prolonged.

Mrs. Annie Jenness Miller, editor of "Dress," says: "In every instance Warner's Safe Cure has the effect to give new energy and vitality to all my powers." Miss Gray, teacher of Oratory and Physical Culture at Syracuse, declares: "Before I tried physical culture and Warner's safe cure, I was a confirmed invalid. I owe much to that excellent remedy, and do not hesitate to acknowledge it."

Human life seems too short, though men in

former ages lived longer than those of the present. History tells us that they lived more in accordance with nature's laws—their mode of living was extremely simple, and in their daily life they followed the dictates of human intelligence.

If sickness comes, we of to-day, seek the remedy among the artificial forces instead of resorting to the field of nature.

If, when diseases come, we would consult nature, the chances are that we would fare better, for we would then treat the cause of such disorders. Modern research has shown that most of the commonly known diseases owe

their origin to the unhealthy state of the kidneys, the blood purifiers of the system, and if they are kept in a healthy state by the use of Warner's safe cure, a vegetable compound and simple production of nature, much of the prevailing sickness would be happily averted.

It is probable that the author of "She" derived many of his beautiful imaginings from close communings with nature, for we are all agreed that whatever is of or from nature is more beautiful and wholesome, than that which is artificially constructed.

• Dinger's Polytechnisches Journal.

CHEMICAL LABORATORY

OF THE UNIVERSITY COLLEGE OF OTTAWA,

Under the direction of PROF. C. F. MARSAN, M.A., Dominion Examiner of Public Analysts, and A. L. TOURCHOT, Demonstrator of Applied Chemistry.

THE MOST COMPLETE OUTFIT IN THE DOMINION FOR ALL KINDS OF ANALYSES.

A SPECIAL DEPARTMENT

Has been just completed for the Analysis of Phosphate, and will be found to answer most satisfactorily the wants of the Phosphate industry.

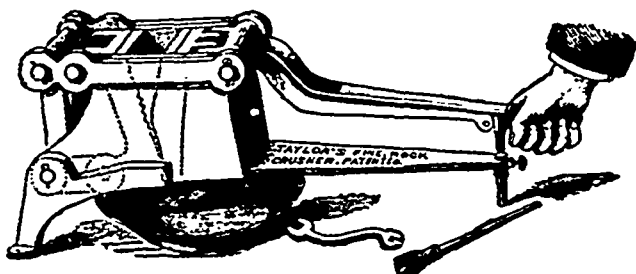

TAYLOR'S LABORATORY ROCK CRUSHER.

The Assayers and Chemists' Friend.

PRICE COMPLETE, \$25.00.
Manufactured and sold by NEW YORK METALLURGICAL WORKS,
101 & 106 Washington St., New York.

E. N. RIOTTE, MANAGER.

Rock Drills, Air Compressors,

General Mining Machinery,

Wire Rope and Contractors' Supplies.

FOR CATALOGUES, ESTIMATES, &C., ADDRESS:

INGERSOLL ROCK DRILL COMPANY,
(LIMITED.)

44 Foundling Street, Montreal.



Wood Working Machinery.

SEND FOR CATALOGUE.

New Saw-Mill Catalogue just out.

154
St. James St.
Montreal.

76
St. Paul St.
Quebec.



WATEROUS ENGINE WORKS CO
BRANTFORD CANADA

BRANTFORD, CANADA.

ST. PAUL, MIN., U. S. A.

E. GAUJOT,

MINING ENGINEER.

BELLEVILLE, ONT.



Notice to Contractors.

SEALED TENDERS addressed to the undersigned and endorsed

Tender for Post Office, &c., Prescott, Ont.,

will be received at this Office until Thursday, 8th March, 1888, for the several works required in the erection of Post Office at Prescott, Ont.

Specifications and drawings can be seen at the Department of Public Works, Ottawa, and at the office of E. Jessup, Esq., Collector of Customs, Prescott, on and after Tuesday, 14th February, and tenders will not be considered unless made on form supplied and signed with their actual signatures.

An accepted bank cheque payable to the order of the Minister of Public Works, equal to five per cent. of amount of tender, must accompany each tender. This cheque will be forfeited if the party decline the contract or fail to complete the work contracted for, and will be returned in case of non-acceptance of tender.

The Department does not bind itself to accept the lowest or any tender.

By order,

A. GOFFIL,
Secretary.

Department of Public Works,
Ottawa, 8th February, 1888.

2-2



Notice to Contractors.

SEALED TENDERS addressed to the undersigned and endorsed

Tender for Iron Stair-cases at New Departmental Building, Wellington Street, Ottawa, Ont.,

will be received at this Office until Thursday, the 11th March, for the several works required in providing and erecting Iron Stair-cases at New Departmental Building, Wellington Street, Ottawa.

Specifications and drawings can be seen at the Department of Public Works, Ottawa, on and after Thursday, 16th February, and tenders will not be considered unless made on the form supplied and signed with the actual signatures of tenderers.

An accepted bank cheque, payable to the order of the Minister of Public Works, equal to five per cent. of amount of tender, must accompany each tender. The cheque will be forfeited if the party decline the contract, or fail to complete the work contracted for, and will be returned in case of non-acceptance of tender.

The Department does not bind itself to accept the lowest or any tender.

By order,

A. GOBEIL,
Secretary.

Department of Public Works,
Ottawa, 8th February, 1888.

2-1



SEALED TENDERS addressed to the undersigned and endorsed

Tender for Cobourg Work,

will be received at this office until Tuesday, the 13th March, for rebuilding a portion of the Western Pier at Cobourg, Ont., in accordance with a plan and specification to be seen at the Department of Public Works, Ottawa, and at the office of the Town Trust, Cobourg.

Tenders will not be considered unless made on the form supplied and signed with the actual signatures of tenderers.

An accepted bank cheque payable to the order of the Minister of Public Works, equal to five per cent. of amount of tender, must accompany each tender. This cheque will be forfeited if the party decline the contract or fail to complete the work contracted for, and will be returned in case of non-acceptance of tender.

The Department does not bind itself to accept the lowest or any tender.

By order,

A. GOBEIL,
Secretary.

Department of Public Works,
Ottawa, 16th February, 1888.

**VALUABLE
PLUMBAGO**

AND OTHER

Mineral Lands

FOR SALE,

IN THE TOWNSHIP OF BUCKINGHAM, COUNTY OF OTTAWA.

1st.—Lot 28, in the 6th range, containing 100 acres, in addition to the salina of the lake.

2nd.—North half of lot 23, in the 5th range, containing 100 acres.

3rd.—Nine acres of lot No. 28, in the 5th range, with water privileges thereto appertaining, being site of mill dam, etc., etc.

The property formerly belonged to the Montreal Plumbago Mining Company, and was worked successfully for several years, until the company's mill was destroyed by fire, but the mill dam remains almost uninjured, and there are on the property several houses, sheds, etc., built for various purposes when mining operations were carried out.

The Plumbago Deposits

upon the property are regarded as amongst the richest and most extensive in the Dominion. As to the quality of the Plumbago, it has been extensively used in the manufacture of crucibles, lubricating leads, stove polish, etc., etc., and given unbounded satisfaction. This is established by the experience of consumers, and by a certificate from the celebrated Battersea Crucible Works, London, England, a copy of which is open for inspection.

MICA

has also been discovered in quantities.

The lands are in the Phosphate region, and recent prospecting has disclosed a rich and extensive deposit of this mineral. There are unrivalled facilities for transporting the ore to and from the mines by the Ottawa River and C. P. Railway. Distance from mines to Railway Station 6 miles. Good road.

All that is required to make these valuable mines handsomely remunerative is a little capital and enterprise.

The Title is Indisputable.

For information apply to

WM. H. DICKSON,
160 Waller St., Ottawa.

H. E. DICKSON,
Russell House, Ottawa.

OR TO THE OFFICE OF

THE CANADIAN MINING REVIEW,
OTTAWA.

**FOR SALE.
VALUABLE
Copper Mining Properties**

— IN THE —

Eastern Townships

TOWNSHIP OF ASCOT.

- 1st. Clark Mine, Lot 11, R. 7 Ascot 187 acres
- 2nd. Sherbrooke Mine, part Lots 12 and 13,
R. 7 Township of Ascot..... 329 "
- 3rd. Belvidere Mine, part Lots 9 and 10, R.
9 and 10, R. 8 Ascot 292 "
- 4th. Mining Rights in same vicinity on..... 250 "

All of the above properties lie within 1½ miles of the Village of Lennoxville, at the junction of the Grand Trunk, Canadian Pacific and Passumpsic Railways, and have been developed to a considerable extent, and veins opened 6 to 20 feet in width, yielding 3 to 5 per cent. of copper, also silver, and 35 to 40 per cent. of sulphur. These mines are only 2½ to 3 miles distant from the City of Sherbrooke, and evidently are of the same class of ores found at Copelton, only four miles distant, owned and worked by the Orford Copper and Sulphur Company, and by Messrs. G. H. Nichols & Co., of New York, which have proved so remunerative.

TOWNSHIP OF ORFORD.

- 5th. Caribuncle Hill Mine, Lots 2 and 3 R. 14, and
2, 3, 4 R. 15, 718 acres. Same class of ore as is found
in the Ascot properties above described, but yielding 2
higher percentage of copper.

TOWNSHIP OF CLEVELAND.

- 6th. St. Francis Mine, ¼ Lot 25 R. 12, 50 acres, with
dwelling houses, smith's shop, ore sheds and office, large
winding and pumping steam engine, with boiler, winding
and pumping gear, and about forty fattons of British lift-
ing pumps complete, railway tracks, ladders, etc., situated
three miles from Grand Trunk Railway. A consider-
able amount of mining work has been done at this mine.
A well defined vein richly charged with vitreous purple
and yellow sulphurets of copper traverse the entire
length of the property, five feet in thickness, yielding 8
to 40 per cent. metallic copper.

TOWNSHIP OF GARTHBY.

- 7th. Fifty-six lots of land, 2,938 acres. The prop-
erty for the most part is unexplored, but copper is found
on the greater part of the property. On one of the lots
a vein about twenty feet in width has been found.
Samples of the ore have yielded as much as 22 per cent.
of copper, being also rich in sulphur. Other samples of
pyrites from the same property, free from copper, have
yielded as high as 48 per cent. of sulphur. The only
drawback to this property is in its distance from the
railway, it being about four miles from Garthby Station,
Quebec Central Railway. A new line is chartered,
however, which, when built, will run directly through
the property.

TOWNSHIP OF ACTON.

- 8th. The Acton Mine, 100 acres, with engine, boiler,
pumps and appliances. Within three years after this
mine was first opened it produced nearly \$500,000
worth of copper. It is situated about half a mile distant
from the stations of the Grand Trunk and South Eastern
Railways.

- 9th. Brome Mine, part Lots 2 and 3 R. 4, 50 acres.
- 10th. Bolton Mine, two miles from Eastman Station,
Waterloo & Magog Railway, 400 acres.

The above properties formerly belonged to the Canadian Copper and Sulphur Company, and were acquired by the present owner at sheriff's sale, giving an indisputable title thereto.

The whole or any portion of the property will be sold at reasonable prices.

For further information apply to

WM. FARWELL,
SHERBROOKE, P.Q.,
CANADA

RUSSELL & CO.,
PROVINCIAL AND DOMINION
LAND SURVEYORS,
CIVIL AND MINING ENGINEERS
PORT ARTHUR, ONTARIO.

Mining Properties Surveyed, Reported on and Dealt in.

Latest and Most Complete Plans of Thunder Bay
Mining District Always on Hand.

A. L. RUSSELL, A. H. MACDOUGALL, W. W. RUSSELL.
P. L. S., D. I. S. P. L. S., D. L. S. M. E. A. M. C. A. S. O. C. G. E.

The Canadian Anthracite Coal Co.
LIMITED.
Miners & Shippers of Coal.

MCLEOD STEWART, Pres., J. G. THORP, Vice-Prest.
OTTAWA, CANADA. EAU CLAIRE, WIS.
A. PUGH, General Manager, W. B. SCARF, Secretary,
ST. PAUL, MINN. WINNIPEG, MAN.
O. H. INGRAM, Treasurer,
EAU CLAIRE, WIS.

Mines at Anthracite,
N. W. T., CANADA. v-1-1y

T. D. LEDYARD,
DEALER IN MINERAL LANDS
4 ONTARIO CHAMBERS, TORONTO.

Will buy undeveloped iron ore and other mineral properties.
WANTED.—Deposits of Magnetic Iron Ore, Red Hematite,
Brown Hematite, Galena, Iron, and Copper Pyrites, Mica, Soap-
stone, Marble, Gypsum, Barite. Samples can be sent by Sample
Post for 7 cent for 4 oz. or up to 24 oz. in weight.
Information regarding mines cheerfully given. Correspondence
solicited. Crown Land Business attended to.

WOLFF & COTTON,
Provincial Land Surveyors,
ONTARIO AND QUEBEC.
OFFICE:—52 ELGIN STREET, OTTAWA.
(Opposite Russell House.)

W. M. HAMILTON MERRITT, F.G.S.
Associate Royal School of Mines, &c.,
Mining Engineer and Metallurgist,
Will report on Mines and Mineral Properties.
ADDRESS:
15 TORONTO ST., TORONTO, ONT.

JAMES HOPE & CO.,
BOOKSELLERS,
Stationers, Bookbinders and Printers,
OTTAWA.

J. HERBERT & SON,
401 and 403--Wellington Street--599
O T T A W A .

Plain and Ornamental Slating, Felt and
Gravel Roofing, &c.

ESTIMATES GIVEN.

Orders Executed with Care under Personal
Superintendence.



Mining Regulations

TO GOVERN THE DISPOSAL OF

Mineral Lands other than Coal Lands, 1886.

THESE REGULATIONS shall be applicable to all Dominion Lands containing gold, silver, cinnabar, lead, tin, copper, petroleum, iron or other mineral deposits of economic value, with the exception of coal.

Any person may explore vacant Dominion Lands not appropriated or reserved by Government for other purposes, and may search therein, either by surface or subterranean prospecting for mineral deposits, with a view to obtaining under the Regulations a mining location for the same; but no mining location or mining claim shall be granted until the discovery of the vein, lode or deposit of mineral or metal within the limits of the location or claim.

QUARTZ MINING.

A location for mining, except for iron on veins, lodes or ledges of quartz or other rock in place, shall not exceed forty acres in area. Its length shall not be more than three times its breadth and its surface boundary shall be four straight lines, the opposite sides of which shall be parallel, except where prior locations would prevent, in which case it may be of such a shape as may be approved of by the Superintendent of Mining.

Any person having discovered a mineral deposit may obtain a mining location therefor, in the manner set forth in the Regulations which provides for the character of the survey and the marks necessary to designate the location on the ground.

When the location has been marked conformably to the requirements of the Regulations, the claimant shall within sixty days thereafter, file with the local agent in the Dominion Land Office for the district in which the location is situated, a declaration or oath setting forth the circumstances of his discovery, and describing, as nearly as may be, the locality and dimensions of the claim marked out by him as aforesaid; and shall, along with such declaration, pay to the said agent an entry fee of FIVE DOLLARS. The agent's receipt for such fee will be the claimant's authority to enter into possession of the location applied for.

At any time before the expiration of FIVE years from the date of his obtaining the agent's receipt it shall be open to the claimant to purchase the location on filing with the local agent proof that he has expended not less than FIVE HUNDRED DOLLARS in actual mining operations on the same; but the claimant is required, before the expiration of each of the five years, to prove that he has performed not less than ONE HUNDRED DOLLARS' worth of labor during the year in the actual development of his claim, and at the same time obtain a renewal of his location receipt, for which he is required to pay a fee of FIVE DOLLARS.

The price to be paid for a mining location shall be at the rate of FIVE DOLLARS PER ACRE, cash, and the sum of FIFTY DOLLARS extra for the survey of the same.

No more than one mining location shall be granted to any individual claimant upon the same lode or vein.

IRON.

The Minister of the Interior may grant a location for the mining of iron, not exceeding 160 acres in area which shall be bounded by north and south and east and west lines astronomically, and its breadth shall equal its length. Provided that should any person making an application purporting to be for the purpose of

mining iron thus obtain, whether in good faith or fraudulently, possession of a valuable mineral deposit other than iron, his right in such deposit shall be restricted to the area prescribed by the Regulations for other minerals, and the rest of the location shall revert to the Crown for such disposition as the Minister may direct.

The regulations also provide for the manner in which land may be acquired for milling purposes, reduction works or other works incidental to mining operations.

Locations taken up prior to this date may, until the 1st of August, 1886, be re-marked and re-entered in conformity with the Regulations without payment of new fees in cases where no existing interests would thereby be prejudicially affected.

PLACER MINING.

The Regulations laid down in respect to quartz mining shall be applicable to placer mining as far as they relate to entries, entry fees, assignments, marking of localities, agents' receipts, and generally where they can be applied.

The nature and size of placer mining claims are provided for in the Regulations, including bar, dry, bench, creek or hill diggings, and the RIGHTS AND DUTIES OF MINERS are fully set forth.

The Regulations apply also to

BED-ROCK FLUMES, DRAINAGE OF MINES AND DITCHES.

The GENERAL PROVISIONS of the Regulations include the interpretation of expressions used therein; how disputes shall be heard and adjudicated upon; under what circumstances miners shall be entitled to absent themselves from their locations or diggings, etc., etc.

THE SCHEDULE OF MINING REGULATIONS

Contains the forms to be observed in the drawing up of all documents such as:— "Application and affidavit of discoverer of quartz mine." "Receipt for fee paid by applicant for mining location." "Receipt for fee on extension of time for purchase of a mining location." "Patent of a mining location." "Certificate of the assignment of a mining location." "Application for grant for placer mining and affidavit of applicant." "Grant for placer mining." "Certificate of the assignment of a placer mining claim." "Grant to a bed rock flume company." "Grant for drainage." "Grant of right to divert water and construct ditches."

Since the publication, in 1884, of the Mining Regulations to govern the disposal of Dominion Mineral Lands the same have been carefully and thoroughly revised with a view to ensure ample protection to the public interests, and at the same time to encourage the prospector and miner in order that the mineral resources may be made valuable by development.

COPIES OF THE REGULATIONS MAY BE OBTAINED UPON APPLICATION TO THE DEPARTMENT OF THE INTERIOR.

A. M. BURGESS,
Deputy Minister of the Interior.

TORONTO BAG WORKS

MANUFACTURERS OF

BAGS for ORES, PHOSPHATES, ETC.,

AND FOR ALL OTHER PURPOSES.

DICK, RIDOUT & CO.,

11 and 13 Front St. East,

TORONTO.

A. R. WILLIAMS,

DEALER IN

Engines, Boilers, Derricks, Steam Pumps and Mining Outfits,

WOODWORKING & IRONWORKING

MACHINERY,

AND GENERAL SUPPLIES.

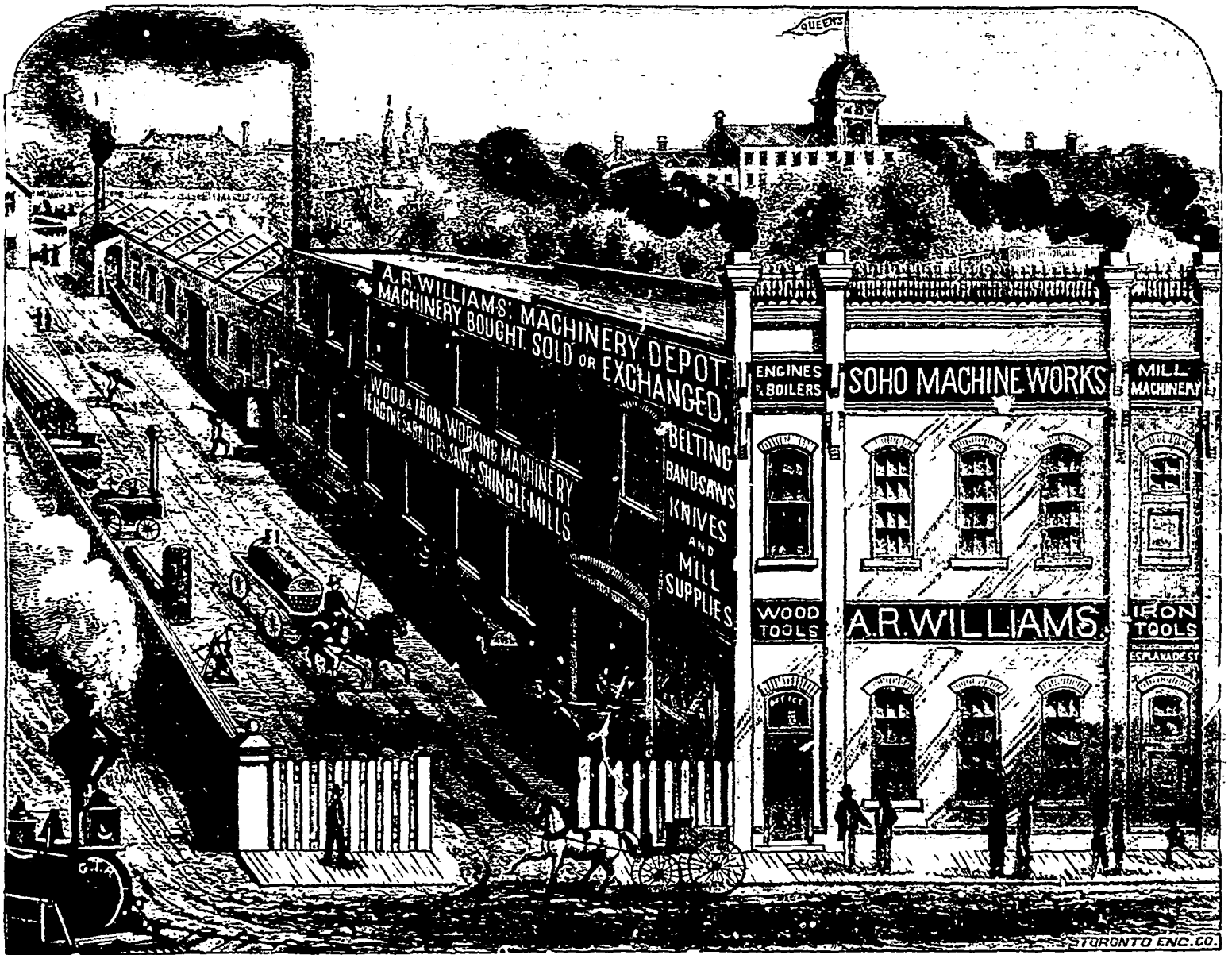

SOHO MACHINE WORKS,

ESPLANADE STREET (NEAR UNION STATION),

TORONTO, ONTARIO, CANADA.