

Technical and Bibliographic Notes / Notes techniques et bibliographiques

The Institute has attempted to obtain the best original copy available for scanning. Features of this copy which may be bibliographically unique, which may alter any of the images in the reproduction, or which may significantly change the usual method of scanning are checked below.

L'Institut a numérisé le meilleur exemplaire qu'il lui a été possible de se procurer. Les détails de cet exemplaire qui sont peut-être uniques du point de vue bibliographique, qui peuvent modifier une image reproduite, ou qui peuvent exiger une modification dans la méthode normale de numérisation sont indiqués ci-dessous.

- | | | | |
|-------------------------------------|---|-------------------------------------|---|
| <input type="checkbox"/> | Coloured covers /
Couverture de couleur | <input type="checkbox"/> | Coloured pages / Pages de couleur |
| <input type="checkbox"/> | Covers damaged /
Couverture endommagée | <input type="checkbox"/> | Pages damaged / Pages endommagées |
| <input type="checkbox"/> | Covers restored and/or laminated /
Couverture restaurée et/ou pelliculée | <input type="checkbox"/> | Pages restored and/or laminated /
Pages restaurées et/ou pelliculées |
| <input type="checkbox"/> | Cover title missing /
Le titre de couverture manque | <input checked="" type="checkbox"/> | Pages discoloured, stained or foxed/
Pages décolorées, tachetées ou piquées |
| <input type="checkbox"/> | Coloured maps /
Cartes géographiques en couleur | <input type="checkbox"/> | Pages detached / Pages détachées |
| <input type="checkbox"/> | Coloured ink (i.e. other than blue or black) /
Encre de couleur (i.e. autre que bleue ou noire) | <input checked="" type="checkbox"/> | Showthrough / Transparence |
| <input type="checkbox"/> | Coloured plates and/or illustrations /
Planches et/ou illustrations en couleur | <input checked="" type="checkbox"/> | Quality of print varies /
Qualité inégale de l'impression |
| <input checked="" type="checkbox"/> | Bound with other material /
Relié avec d'autres documents | <input type="checkbox"/> | Includes supplementary materials /
Comprend du matériel supplémentaire |
| <input type="checkbox"/> | Only edition available /
Seule édition disponible | <input type="checkbox"/> | Blank leaves added during restorations may
appear within the text. Whenever possible, these
have been omitted from scanning / Il se peut que
certaines pages blanches ajoutées lors d'une
restauration apparaissent dans le texte, mais,
lorsque cela était possible, ces pages n'ont pas
été numérisées. |
| <input checked="" type="checkbox"/> | Tight binding may cause shadows or distortion
along interior margin / La reliure serrée peut
causer de l'ombre ou de la distorsion le long de la
marge intérieure. | | |
| <input checked="" type="checkbox"/> | Additional comments /
Commentaires supplémentaires: | | Continuous pagination. |

SCIENTIFIC CANADIAN

MECHANICS' MAGAZINE

AND PATENT OFFICE RECORD

Vol. 10.

DECEMBER, 1882.

No. 12.

NOTE AND COMMENT.

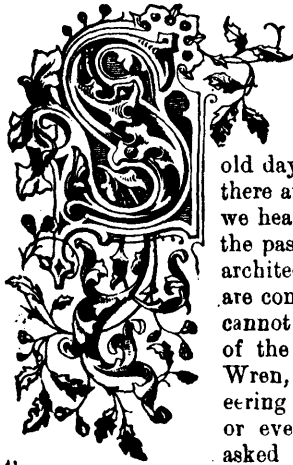

SOME persons are eternally talking of the past. Nothing of the present satisfies them. They are for ever dinning things of the old days into our ears. Perhaps there are no walks of life in which we hear so much about matters of the past as in the professions of architecture and engineering. We are constantly being told that we cannot design like the architects of the time of Sir Christopher Wren, nor perform feats of engineering like the Greeks or Romans, or even the Egyptians. If you

asked these same persons what the Greeks or Romans, or even the Egyptians, had done in the way of engineering they would not probably in every case be able to tell you, still they will keep chattering on about the glorious works of the ancients, or the everlasting examples of masonry that were constructed before the time of the Flood. We do not say that useful lessons are not to be drawn from the past, but we think that the constant harping on the old days is likely to prove, in the interests of architecture or engineering at least, more injurious than otherwise. Let us rather believe that we can do just as good work now as ever was done in the world's history, and it is probable that we shall profit far more in our labour than if we keep on moaning and groaning about the degeneracy of the arts and sciences, whether in connection with architecture or engineering, or in any other respect.

Most extraordinary statements are frequently to be met with as regards architecture. A Mr. Clarence Cook has been writing in the *North American Review*, and saying that "The general excellence which marks the dwellings of any people is a proof of the non-existence of professional architects among that people," and

further, that "where architects abound the art of building always deteriorates." In support of this he cites the structures of revolutionary days, in many of which he says (and we cannot say he is altogether wrong in saying it) "there is a sense of proportion, of picturesqueness, and of comfort," in which the dwellings at the present time "are particularly wanting;" and he calls attention to the fact that all those structures were the work of "simple builders, who knew their trade, and never cared to give themselves a finer name." Proceeding with his argument, Mr. Cook affirms that "architects may have designed the bad houses of Venice, but never the good ones," a statement, of course, which we are by no means bound to accept. He instances Swiss chalets as examples of a kind of building which owes nothing to culture, science or archæology, and yet exhibits in its direct and skillful satisfying of the conditions imposed by local circumstances and taste, a degree of that beauty of fitness known as "style" which no other modern architecture can surpass. This is true enough to an extent, but are we going to set the pretty Swiss chalet against the modern requirements in the architecture of a great city?

Our able contemporary, the *American Architect and Building News*, in taking Mr. Cook to task for his remarks, says that one who studies the architecture of the revolutionary period "is apt to be constantly surprised; not at the simplicity with which the problems of house-building were met, but at the sacrifices of convenience which our forefathers made for the sake of external effect. Fond as we profess to be of picturesqueness in the design of houses, we doubt whether any architect of the present day could persuade a client into reducing the height of his kitchen at one end to four or five feet, as was often done a hundred years ago, apparently with the sole object of including it with the rest of the house under that broad sweep of roof whose beauty we seek in vain to reconcile with modern requirements; or whether he could plan a building with ceilings crossed by beams less than six feet from the floor, or steps at unexpected intervals in the passages, such as we admire so much in our ancestors' houses, without forfeiting the esteem of his contemporaries." No, the

architect cannot always please himself, and a critic like Canon Farrar should not forget that there is such a person as a client whose wants must be satisfied.

CHIMNEYS.

We think we may venture the assertion that at least one-half of the chimneys in use to-day are altogether too small to economically serve the purpose for which they are used. There seems to be a very general misunderstanding in regard to their correct proportion among those most deeply interested in their efficient performance, viz., the owners of the chimneys themselves.

The object of a chimney is, of course, well known to be the means by which the draught necessary for the proper combustion of the fuel is produced, as well as to furnish a means of discharging the noxious products of combustion into the atmosphere at such a height from the ground that they may not be considered a nuisance to people in the vicinity of the chimney.

Regarding the second of the above purposes for which chimneys are built, we need only say that it is of secondary importance only, and that where due attention is given to the proper methods of setting boilers and proportionating great areas, furnaces, and rate of combustion, the smoke nuisance is comparatively unknown, and is of no practical importance whatever.

The main points then to be considered in designing chimneys are the right proportions, to insure, first, a good and sufficient draught, and second, stability.

Without entering into any demonstration of the velocity of the flow of the heated gases through the furnace and flues leading into and up the chimney, we will briefly state a few of the principles governing the dimensions of chimneys. The motive power or force which produces the draught is the action of gravity upon the difference in the specific gravities of the heated column of the gases of combustion inside the chimney, and the atmosphere at its normal temperature outside of the chimney, by which the former is forced up the flue; and the laws governing its velocity are the same as those governing the velocity of a falling body, and it can be proved that its velocity, and, consequently, the amount or volume of air drawn into the furnace and which constitutes the draught is in proportion to the square root of the height of the chimney. It is a common error that the force of the draught is in direct proportion to the height, so that, with two chimneys of the same area of flue, one being twice the height of the other, the higher one would produce a draught twice as strong as the other. The intensity of draught under these circumstances would be in the proportion of the square root of 1 to the square root of 2, or as 1 to 1.42. To double the draught power of any given chimney by adding to the height it would be necessary to build it to four times the original height. Practically there is a limit to the height of a chimney of any given area of flue beyond which it is found that the additional height increases the resistance due to the velocity and friction more rapidly than it increases the flow of cold air into the furnace. For chimneys not over 42 in. in diameter the maximum admissible height is about 300 ft.

From an investigation of the same laws we find that the velocity of the flow of cold air into the furnace is in proportion to the square root of the ratio between the density of the outside air, and the heated gases in the chimney, from which we may deduce the fact that very little increase of draught is obtained by increasing the temperature of the gases in the chimney above 500 or 600 degrees Fah. By raising the temperature of the flue from 600 to 1,200 degrees we would increase the draught less than 20 per cent., while the waste of heat would be very considerable. Conversely, we may reduce the temperature of the flue about one-half when the temperature is as high as 600 degrees by means of an economizer or otherwise, and the reduction of draught force would be only about 20 per cent., as before.

It is found that the principal causes which act to impair the draught of a chimney and which vary greatly with different types of boilers and settings, are the resistance to the passage of the air offered by the layer of fuel, bends, elbows, and changes in the dimensions of the flues, roughness of the masonry of brick flues, holes in the passages which allow the entrance of cold air, and generally any variation from a straight, air tight passage of uniform size from combustion chamber to

chimney flue, and the resistance to draught is in direct proportion to the magnitude and number of such variations.

In designing a chimney, it is, therefore, always necessary to consider the type of boiler, method of setting, arrangement of boilers and flues, location of chimney, and everything which will be likely to in any way interfere with its efficient performance. Much, of course, depends upon the judgment and experience of the designer, and it would be impossible to give any general rule which would cover all cases. When only one boiler discharges into a chimney, for instance, the chimney requires a much larger area per pound of fuel burned than when several similar boilers discharge into a chimney of the same height, and taking all these varying circumstances into consideration, a great deal of judgment is in many cases required to determine the proper dimensions.

It is a common idea that a "chimney cannot be too large"—in other words, that the larger the area of the flues the better the draught will be, but this is not always the case. In many cases where a chimney has been built large enough to serve for future additions to the boiler power, the draught has been much improved as additional boilers have been set at work. The cause of this is to be found in the increased steadiness of draught where several boilers are at work and are fired successively, as well also as in the better maintenance of the temperature of the flue, as the velocity of the gases necessarily increases with the increased amount required to be discharged, and they do not have time to cool off to so great an extent as when they move more slowly.—*Building and Engineering Times.*

OPERATIONS IN RUBBER.

Within a short time the price of Para rubber has risen from 95 cents to \$1.25 a pound, making the price the highest ever reached in this city, and nearly double what it was two years ago—the result, it is said, of a corner by a few great operators. Most of the supply is held in Europe, though two-thirds of the rubber produced is worked up by American factories.

A meeting of seventy rubber manufacturers, representing capital to the amount of \$30,000,000, and over 60 firms employing from 15,000 to 25,000 hands, was held in this city, October, 19, to devise means for defeating the corner. One of the means proposed was a general stoppage of work; another the formation of a purchasing bureau at Para. With the exception of a single company all the rubber firms of the country have entered into an agreement by the terms of which the packing, hose, and belting makers were to reduce the production 25 per cent, after the first of this month, and the manufacturers of shoes and clothing are to shut down altogether after the 23rd of December, that condition to continue until such time as the price of rubber warrants resumption.

The corner is confined to the high grade Para rubber, and has nothing to do with the common grade of Central American, Bornean, and African rubber. The cheap grades have, however, advanced fully fifty per cent in price, through sympathy. The stock of rubber in this city and Boston, it is said, is practically exhausted, and none is expected until the arrival of three ships from Para about Nov. 1. Some of the manufacturers find themselves embarrassed by the situation, while others, who have large stocks of crude rubber on hand, find it very profitable. In Para there are about 150 receivers of rubber who control the negroes who gather the gum. These receivers sell their stock to eight shippers, and several of these shippers are controlled by the corner.

EVERY corpse that is taken to the Paris Morgue is now quickly converted into a block almost as hard as stone. This result is obtained by Carré's chemical refrigerator, which is capable of reducing the temperature of the conservatory, where each body is laid out on something closely resembling a camp bedstead in stone, to 15° below zero centigrade. At the back of this room is a row of stove like compartments, in which the corpses are boxed up and frozen hard before being exposed to public view. As an illustration of the intense cold thus artificially secured, a Paris journalist in describing a recent visit to the Morgue, says that in opening one of the compartments the attendant took the precaution to wear a glove, lest "his hand should be burnt by contact with the cold iron." The corpse which was taken out of its receptacle had been there nine hours. The doctor who accompanied the visitor struck the dead man on the breast with a stick, and the sound was just as if he had struck a stone.

Mechanics.

PLANE TORK.

From *IZACH SKINER, Sarykuse, N. Y.*—I hev workt at kerrige makin ni enter fifty yeres an a little ouver an koncork-wentle think i no sumthin abowt the bizeniz. I rede awl the papers about kerridge an wagen makin an notis that a good many things wat tha print wud be beter if tha was uzed az tha uze kontestin delergaits at nomernatin konvenshuns witch iz to leeve em out.

Nou wat i want ter sa iz this : i hev got dun werkin at the bizeniz an am taken it ezee an am willin to devoat sum of mi spair tym in telin yu mi egspereants az a jerneman prentis an boss—that iz ef yu air wilin tu print gest az i rite it. I no i aint mutch ov a speler bekos i didnt hev the chans to poast on the spelin skule az tha du nou. I cant sea az it maiks mutch diferents abowt the spelin az long az i tell yu sum komen sents.

I did rite wun or tew peeces for the papers sum yeres ago but tha didnt print them az i rit them an i stoped rite short oph, koz every bobby node i waz a poor speler an sed the peeces wazent myn. So i kum to the konklushun ef i ever rote fer the papers agin that the noozpapers wuld hev to print az i rit it or not at awl. I am movin abowt from plier to poast an en-goying miself an am hear to da an thair termorer an sea mutch to rite abowt, things witch i beleave wille be interesten tew everee kerrige maiker.

I sean a surkeler the uther da about the pryzes tew bea given bi the konvenshun this yere, saiin that tha want a essa abowt prentisiz. Now i hev had a grate manea prentisiz in my tym an hev had mutch xpearentis in that bizeniz an ken tell a gudeal abowt it. I kant sea az it maiks aney diferents ef i wright a essa an let yu print it so hear gos mi essa.

Prentisiz is kurious kreter and yet we kant git along with-owt em vere wel—owt or prentisiz we maik jerneymen an bosses an less wea git the rite stuf an dres it up rite an hev it therelea sezenead wea air shure tew maik a botch job. Taint no yuse triin tew maik a paneter owt ov a boi wat wants tew bea a blaxmith or a trimer, it aint enee yous tew put a boi at the foarge wat wants tew goe in the bodee loft. You mite as well tri to taik the kick owt ov a guvement mule.

Ef a boi wants to be a taler or a lawier or a kountergumper or a farmer tant a taul likly yu kan maik a paneter, bodie-maiker, blaxmith or trimer ov him, taint in him, an wot aint in him yu kant git owt ov him—yu mite az well tri tew git the kink owt of kurlid hare or the kerl owt ov a spits dorg's tale. Let him hev his oun chois, let him hev the run ov the shop for a weak or tew with owt doin mutch ov enything, an sea wot is goin on—befoar he kums hev the water klozet nicle wite washed. Giv him a gud big led pensel a peace ov red chork and a jak nife. Watsh an sea if he spends mutch tym there—giv him a fu sents tew bi apels nuts an kanandes with an sea if hea etes them thair, an sea if hea karves his naim awl oaver the wawls ad shaid the karvin with red chork an rites his naim awl oaver the wawls, if he doz let him drop owt ov the line an put a nuther boi in his plai. A yung man wat hez no uther ambishsun than tew karve and sea his naim dekorait a water klozet wil never karve a naim in the world ner rite his naim mene tymes on the bizeniz end ov a bank chek.

His taists wunt mownt tew mutch—and he iz shure tew be a loyterer—yu wil awlwais hev tew tag after him the saim az yew wud after a gote in a yung orchid—this kynd ov a yung man wud dew beter at a plow tale or spreding dung on a ten aiker lot, i hev sene lots ov gust such felers forte yeres owld drivin hosses on the eree kanal. Ef he hez handz petty near as big az the leeves of a skunks kabag or a elefants feet yu mai be shure he will never bekum a artist in ene branch ov the traid, he mit maik a gud helper or a ruff stuff ruber or a gud man in the sau mil, he wud be fust klas on hevly lifitin. It wudent dew tew diskuridge him, he mite hev a hed chuck ful ov wizdom, he mite maik a gud man in the ofis, perhaps a sailman, wile his handz wud be tew klumze to bekum a perfect mekanic he mite hev gust the rite kind ov stuff in him to maik a gud manager. it don't often happen houerter that bois or men with grate big hands ever mount tew mutch but gud natered wel mening hard workin onest felers.

Watsh him an sea ef his habits air ov the klene kind—bekoz a sluvn boi wil never bekum a smart klene jurneman. Thro or plais on the flore were he has to work nales, skrews, wash-ures, rivets, boalts, sanpaper and sitch stuf an sea if he warks

oaver them with owt pikin em up—if he lets em lai drop him like a hot pertater, he haint got ekonome enuf in him to keap him from starvin. But ef he piks up the traps and puts em awa yu kan bait yure botem doler he is a trump and worth moren a full hand ov the uther kine.

Lai a bord on the flore with the nales stikin up—put the trusels in the pasige wa lai a planck or tew in his road an thro a lot ov shavins on the flore an awl sitch things gest to tri him, ef he piks up the bord and nocks the nales out an puts them an the bord away and klenes up the pasige wa, yeu kan be shure he iz az ful ov order az a eg is ful of mete, his tules wil awlwais bea in gud kondishun hiz werk wil awlwais be dun rite. Ef he lets evere thing lai gest as yu put it let him slyde ef yu doant he wil maik ure kart aik, he wud maik a fust rait feler to tred fer klams but wud never mount to mutch arowned a keridge faktore.

Tri him an sea ef he iz manerle sea ef he nos hou to say mister an yes sur an kno sur, fine owt ef he awlwais wants tew stik in hiz gab when yu air talkin with the men or a kustomer, ef he doz he wud bea a gud feler at a kamp meatin or a prizee fite. He wud maik a fust klas kryer fer a syd sho at a serkus—but wud never mount to mutch az a keridge meiker onles it woz at a stryke for short tym an moar wagis. Ef he iz gust tother weigh hold onder him yew mite find gud stuff in him that wud dress up perty gud an maik a fare gob ov him—

Bi a half dym nevil an sum gud buke on mekanics an lai them wair he kan sea boath ov them at wonst, ef he taiks up the fiv senter an stryks a B line fur the water klozet let him lite owt—send him west to fite the red skins—or get him a gob as a prentis to a kar dryer. He wud be a fust klas at a walk in getin oph gost stores an sich but wud never sten the gost ov achans ov becomin a keridge maiker—ef he gos fer the buke on mekaniks luks at it lais it a wun syd an asks yeu ef he kan, taik it hoam an rede it—put him on yure pairole at wunst and giv him his tules an set him at werk an yeu kan rest kontented that he wil pan owt awl rite in the end—

Ef he spends the tym ov his probaishun lukin owt ov the winders an throin shaders with a lukin glas akros the strete or talk with his fingers to the hyered gal akros the strete, let him skip fer thair aint the leest shader ov a werkman in two, ef to the kontraire he watches to sea how the werk is dun and prys around it yu kan gest sai to yurself that he iz trew grit and wil pul thru ef the tyd doz run a strong flud.

Get in a kornr abowt belwring an sea hou kwick he kan lite owt of the shop ef he beets awl the rest let him stai out but ef he stais brushes the dust oph his kloze shets the winders puts up his tules and luks around tew sea ef evereething is awl wright, maik a little bet with yure self duble it an then stradle the dubble that yew hev got a dimund an yew wil win everee tym.

Ef he iz awful ankshus to go fer bear an twys az ankshus to help drinck it yew had better tri and git him a gob az a bear shuver in a larger bere salune or in a bruerree. Ef he kinder kiks abowt goin fer it on princerpel he is a gud boi but ef doz goe fer it without komplante he is akkomadatin an ef he refuzez tew drinck ene of it keap him at werk his breth wil never giv yew the delearum trimens.

Ef you send him ov a erend and he stais awa long dont let him kum back, ef he goz kwick he is awl rite and wil awlwais remane so.

Awl of theas tryels mai fale and yett luk fare on the start. I hev ben fuled a gud menea tyms an koncluded a gud menea yeres agoe to never taik another endentered prentis. I think it is the hite ov phoolishnes fer a man to stik hiz signerter on the bizenez end ov a paper and promis to lern a boi a traid that aint got ene moar brane in him than a trea tode or a katerpillard, ef a boi wunt lern an kant lern yew might az wel give up, ef you kan sukcede in takin the jump owt of a grasshoper, the sting owt of a hornet, the kick owt of a mule or maik a win mil run with water yew mite sukcede.

Tords the last i jest giv up the bizenez of indenter i tuk prentisiz on kondishuns, ef tha terned out awl rite wel and gud ef not I wazent bound to keap em on hand at a los. Ef the boi has grit in him push him ahead—treat him jest az the yew thawt him a man—show him how, praze him when he dezerves it, dont skoald him tew mutch, keap him awa from the men az mutch as possible at nune and nite, improve his mind—giv him buks on mekanicks to rede and studee. Watch over hiz progres, dont be afrade to giv him plentee of kinenis, giv him a raze on his wages when he dezerves it, no mater ef yew dew pai him ten dollers a week in the last yere he erns it an dont oaw yer enethin—an this is mi esa on prentis bizenez.—*Blacksmith and Wheelwright.*

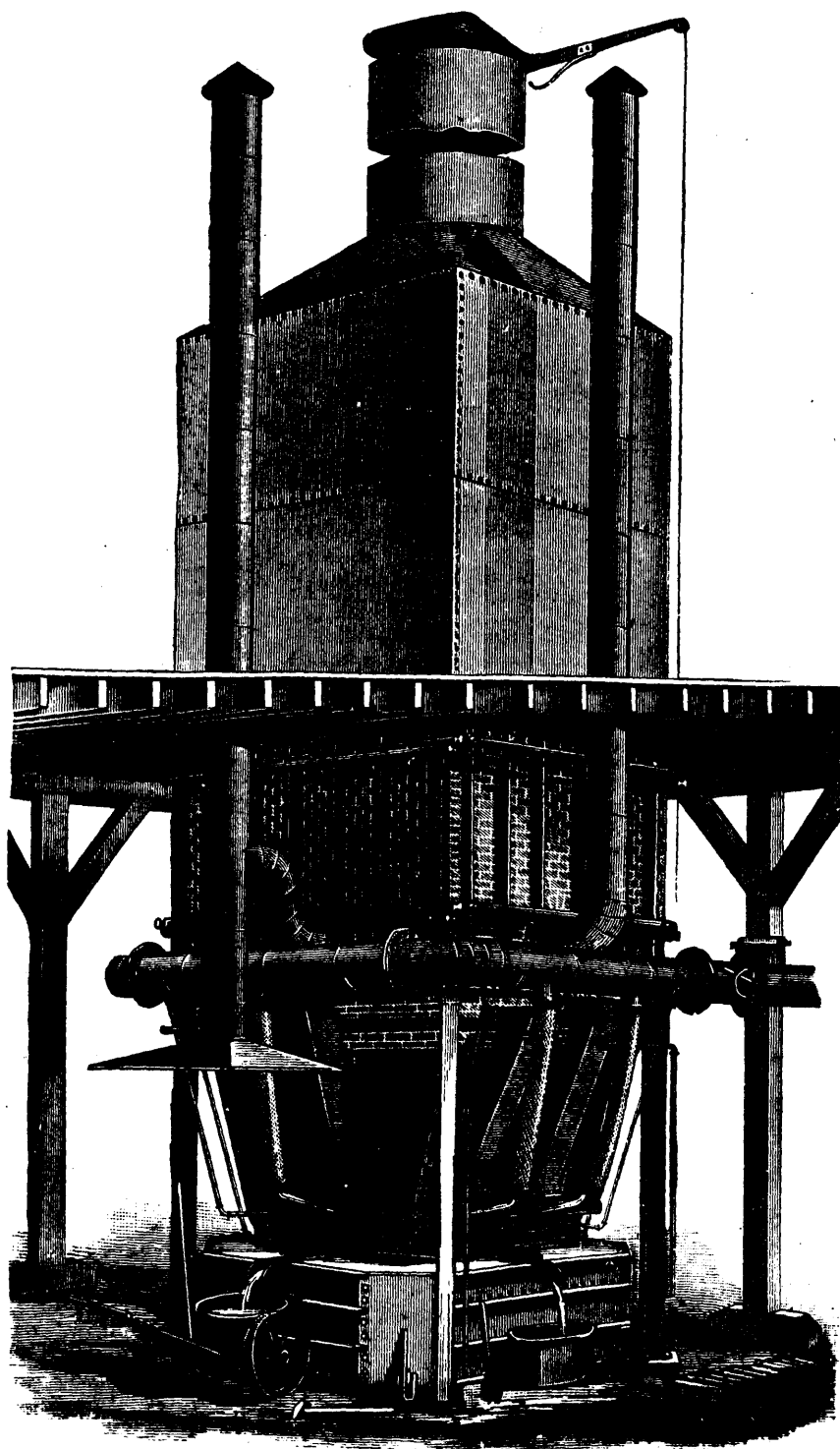

SMELTING FURNACE MANUFACTURED BY THE LANE & BODLEY COMPANY, CINCINNATI.

Fig. 1.

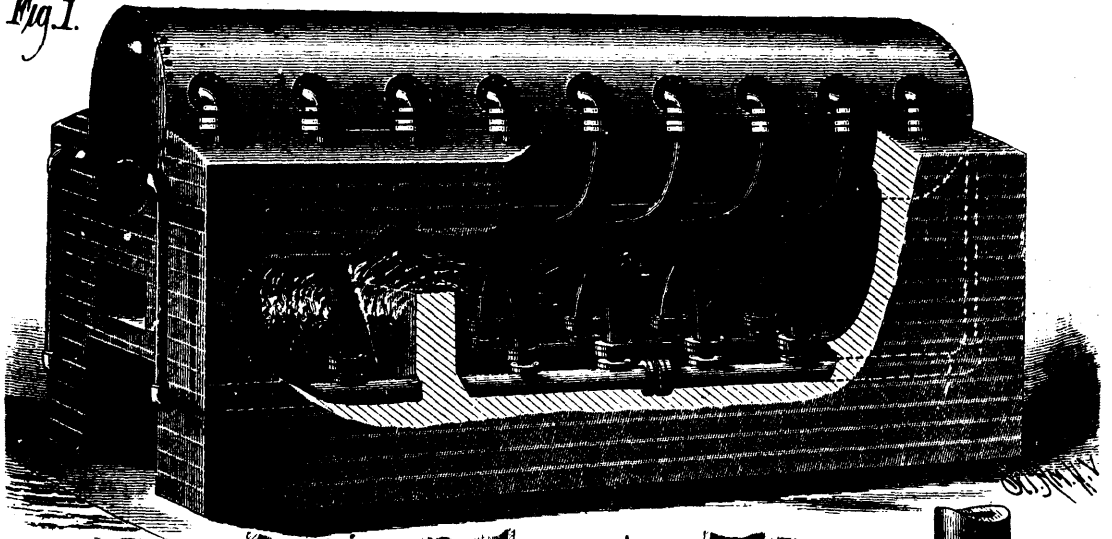

Fig. 2.

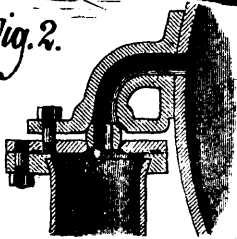

Fig. 3.

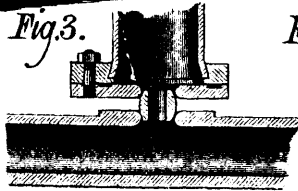

Fig. 4.

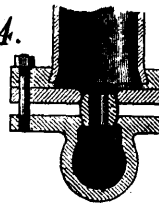
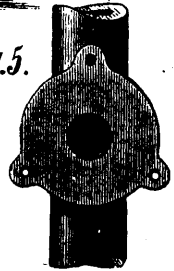

Fig. 5.



HILL'S IMPROVED BOILER.

Fig. 1.

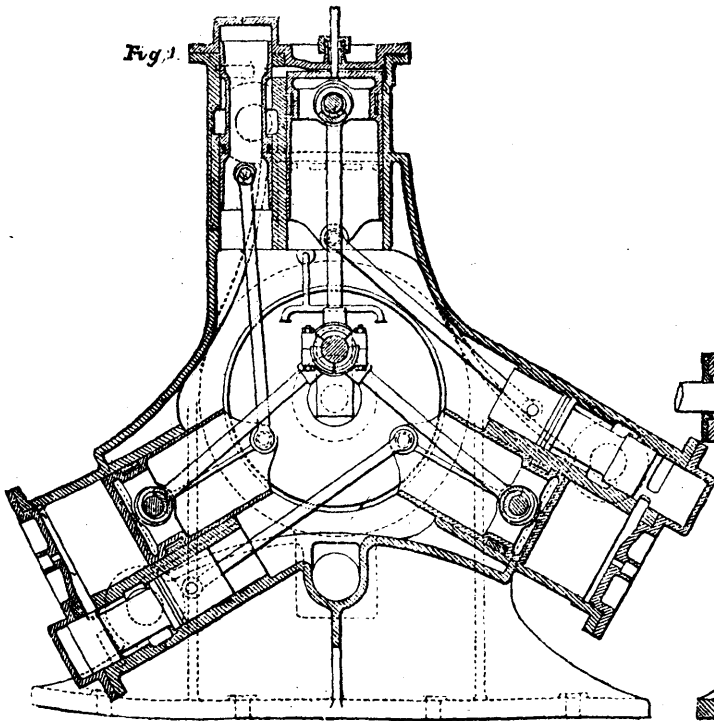
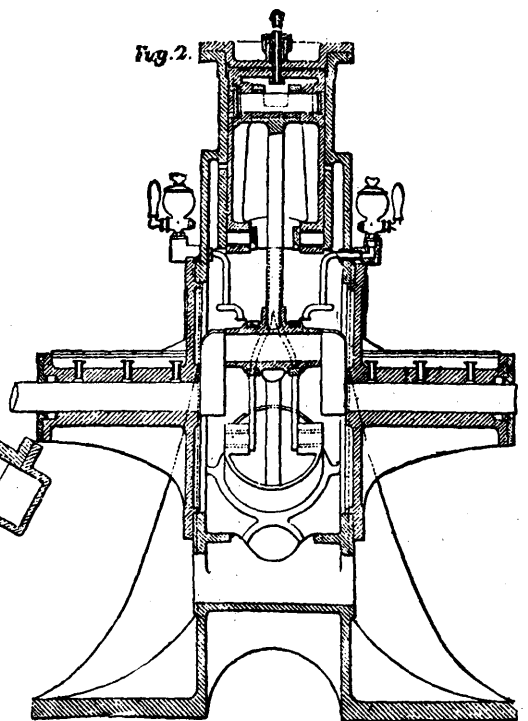

Fig. 2.



IMPROVED THREE-CYLINDER ENGINE.

Engineering, Civil & Mechanical.

A NEW SMELTING FURNACE.

The remarkable increase within the last few years in the production of argentiferous lead in connection with the great commercial success of the operations as exemplified at Leadville, Colorado; Horn Silver Mining Company, Utah; Eureka and Richmond Consolidated, Nevada; and numerous other almost equally great enterprises, has naturally stimulated improvement of methods of reduction. The new smelting furnace, manufactured by the Lane & Bodley Company, Cincinnati, possesses several features that we think of sufficient importance to describe in this article.

Whenever the use of cast iron has heretofore been objectionable on account of liability to breakage from unequal expansion or other cause, wrought iron has been substituted; also in other places where the use of cast iron resulted in great weight, a similar substitution of wrought metal has been resorted to, thus producing a furnace of maximum strength and durability with minimum weight.

The ground plan of the crucible binders is that of a rectangle with the corners chipped off, thus allowing the upright supports of the deck-plate to be entirely independent of the masonry within the binders. The uprights are wrought iron I beams in lieu of the usual cast iron columns, thus avoiding weight, securing more room, and the flanges on the sides forming excellent racks for supporting bars and other implements used about the furnace.

The usual troublesome cast iron deck plate is superseded by I beams, the space between them being utilized as a channel to conduct off the noxious gases and fumes that escape to a greater or less extent from all furnaces, owing to the pressure within, due to the blast pressure; from the channel above mentioned are flues to conduct the gases, etc., to the outside of the stack building.

At the feed door is a ledge a few inches high, thereby requiring the feeder to throw the charges over it into the furnaces, thus preventing the charges being shoved in, and the fine materials all falling in one side of the furnace.

The space between the crucible and deck plate can be filled with brick and water tuyeres or spray jackets, or water jackets of cast iron, wrought iron, or steel, with closed or open tops; the engraving represents open top steel jackets. Jackets of this construction have been thoroughly tested at the large new smelter of the Horn Silver Mining Company near Salt Lake City, Utah, and proved to be the most economical, although of somewhat higher original cost, than other forms of jackets. These jackets are constructed by forming the sheet next to the fire into a box six inches deep, the corners being shaped up without cutting, welding, or riveting (the back is formed by a shallow box fitting into the deep one), resulting in a presentation of no welded or riveted joint to the action of the fire, excepting where the bronze metal tuyere thimble is secured by countersunk rivets to the inside sheet of the jacket, and from which no trouble has resulted, owing to precautions taken in the details of construction.

The end jackets do not run down to the crucible, the spaces so left being closed by small jackets with the tap hole through them; these small jackets can readily be removed without disturbing the main end jackets, in cases of necessity admitting the introduction of a bar without "running down the furnace."

One of the most fruitful sources of annoyance about furnaces is the blast and water pipes; in this furnace the details of these pipes have received great care. The blast pipes do not interfere with putting in or removing jackets, and they are out of the way of water pipes, permitting of readily repairing the same. The blast pipes are not in the way in bricking up from top of jackets to deck plate. All the water pipes are readily accessible for repairs, and the water pipe valves are within easy reach of the furnaceman, yet out of the way in working around the furnace. The water pipes and valves are so arranged as to admit of removal, and repair of any jacket without disturbing the water supply, or connections of other jackets.

There is frequently considerable trouble in keeping jackets properly cool, when first starting, upon account of their not being protected with a layer of chilled slag; this trouble is found to be entirely overcome by the use of an auxiliary supply, obtained through the connection to the block off hole in

each jacket, which supply is only used under the circumstances above indicated.

The brace under the slag spout is notched in steps for the purpose of catching the edge of slag pots, thus holding them level without putting a block under the foot of the pot carriage; such blocks being a source of annoyance, as the slag pot wheels frequently strike them, causing the hot slag to be spilt.

Frequent reference has been made to details, as they are an indication as to the convenience in the operating of any device.

In this furnace the maximum strength and durability with minimum weight are secure, and there is no piece but admits of ready transportation. The total weight is very small, consequently cost of transportation small. There are no cast iron parts liable to break, and all parts are readily removable for repairs. The escaping noxious gases and vapors are carried off. The forms of all essential parts have been approved in practical working.—*Sci. Amc.*

IMPROVEMENT IN STEAM BOILERS.

We give an engraving of an improvement in boilers lately patented by Mr. S. L. Hill, of 68 South Fourth St., Brooklyn, N. Y. In this boiler the inventor, by adding external water tubes, utilizes a great amount of heat that usually goes to waste, and thereby increases the capacity of the boiler without increasing the quantity of fuel consumed.

The boiler not only has this economical feature, but it is made safer and more durable by the addition of the water tubes. If the water contains any foreign matter likely to form sediment, it will be deposited in the horizontal pipe below the fire line.

Steam made in the tubes passes directly to the steam room of the boiler, and water is supplied to the water tubes by pipes leading from the water space of the boiler at each end. The curved tubes offer considerable protection to the fire sheets of the boiler, as they come between the fire and the boiler, and prevent the bottom of the boiler being burned. This is especially advantageous where the feed water is very impure.

One of the principal advantages of this boiler is the facility with which it may be put together or taken apart. The ends of the water tubes are expanded into wrought iron flanges, to which cast iron reducers are secured by ordinary bolts, as shown in the sectional view. The joint is formed by two such reducers, connected by a double cone hollow plug, upon which the reducers are clamped by the coupling bolts. The peculiar form of the plug renders the joint similar to a ball and socket joint, and insures a tight joint, while allowing the pipes to expand and contract.

It will be noticed that none of the joints are exposed to the fire; they are consequently never corroded, and may be taken apart and put together whenever necessary without injury and without creating leaks. The great capacity of this boiler, its safety, and economy are points worthy of the notice of steam users.

IMPROVED THREE-CYLINDER ENGINE.

We give engravings of a new pattern of three-cylinder engine constructed by Mr. Jabez James, London, the engine being one designed and patented by Mr. James, in conjunction with Mr. Walter Wardrope. The special features of the engine are the arrangement of the valves and ports, and the manner in which the valves are driven.

Referring to our illustrations, it will be seen that the engine has three single-acting cylinders, each of which is provided at its outer end with a short straight port leading to the corresponding valve casing. The slide valves are piston valves, and the cylindrical casing in which each valve works communicates at its outer end with the exhaust, while the central portion of its length is in communication with the steam supply. In addition to the port just mentioned, the opening and closing of which is controlled by the valve, each cylinder has other exhaust ports, so placed that they are uncovered by the piston when the latter has made about five-eighths of its stroke toward the crank shaft; these supplementary exhaust ports are shown dotted in Fig. 1, and in section in Fig. 2, from which their arrangement will be readily understood. These supplementary ports permit of the escape of a large proportion of the steam, as the piston, after having uncovered them, moves but slowly, so that they are left uncovered during a considerable fraction

of the revolution. As will be seen from our engravings, the exhaust steam enters the engine casing in which the crank revolves, and finally escapes at the bottom of the exhaust pipe.

The manner in which the valves are driven will be readily understood in Fig. 1, from which it will be seen that each valve is driven by a rod connected to the piston next in the rear of it, the engine illustrated being arranged so that, looking at it as in Fig. 1, the crank-shaft would rotate in the direction of the hands of a clock. It will be noticed that the arrangement of valves and steam passages adopted allows of the connecting rods being made long, without causing any increase in the clearance spaces due to lengths of steam ports.

The crank shaft has very long bearings on each side of the crank, and also a very long crank-pin bearing as shown in Fig. 2, so that the engine is well adapted for high speeds. Power can be taken off either end of the crank shaft, and the arrangement allows the engine to be accurately balanced. One of these engines shown at work lately at Mr. James's factory, ran exceedingly smoothly and steadily. This engine has 6-inch cylinders and 6 inch stroke, and is capable of being worked up to forty indicated horse power; at present, however, it has been worked up to 16 horse power only, on account of an insufficient steam supply. The engine illustrated is fitted with single slide valves only, but the engines are also arranged to be fitted with expansion gear constructed on the compound system. In another arrangement adopted, the valve rods, instead of being coupled to the pistons, are coupled to the connecting rods, it being thus possible to vary the cut-off within wide limits without incurring complication.—*Engineering.*

PROJECTED AMERICAN LINE OF FAST OCEAN STEAMSHIPS.

The decline in ship building and shipping interests, so noticeable in the United States, promises to be retarded by a new project now being promoted by prominent capitalists in this country; the project being nothing less than the establishment of a new line of very swift express steamships, calculated to cross the Atlantic in five and one-half days.

The importance of shortening the time of passage to this extent can scarcely be overestimated. It would not only facilitate business transactions between this country and Europe, and add greatly to the comfort and convenience of passengers, but would also increase the amount of service accomplished by each steamer.

This new project is based on a novel form of vessel, which render high speeds possible, while at the same time adding greatly to the carrying capacity as well as the stability of the vessel. This new model is the design of Captain C. G. Lundborg, who has patented it both in this country and in Europe.

While the general appearance of the vessel is shown by our engravings, it will be necessary to enter somewhat into the details of construction, and into the theories upon which the new construction is based.

The design while affording ample space for passengers and valuable cargo, has been prepared with the primary object of attaining a velocity of twenty to twenty-one knots an hour, with a comparatively moderate expenditure of power. The prominent idea involved is that of making the main body of the ship divide the water horizontally instead of vertically. By adopting this system of construction it becomes possible to build a ship of the greatest capacity for a given draught—an advantage which speaks for itself. But besides this it is also evident that this ship of shallow draught and great capacity can have admirable lines. In other words, her resistance may be reduced to a minimum. The principle admits of the naval architect imparting to his ship a splendid clean run aft, and the screws can be carried far astern and yet be well supported. The advantages to be derived from thus placing the screws far astern have been insisted on by the late Mr. Froude. It will also be seen that no scheme has ever before been put forward which is so perfectly adapted to the use of twin screws. When it is desired, the stern of the ship can be carried further aft, to protect the screws; but this, it is claimed, would probably be unnecessary. There is ample room provided for engine power, notwithstanding the excessively fine run of the hull aft. The accompanying table contains the principal dimensions and other important data:

Length of hull below water on the plane of greatest beam	450 ft.
Greatest breadth	66 "
Length on load water line	444 "
Breadth on load water line	58 "

Draught of water on load water line	23 ft.
Length over all on upper deck	475 "
Breadth on upper deck at greatest transverse section (outside of frames)	62 "
Depth from top of upper deck beams to bottom plating	41 "
Height between the upper and second decks	9 "
Height between second and third decks	9 "
Height between third and orlop decks	8 "
Area of greatest immersed transverse section	1,412 sq.
Coefficient of greatest immersed transverse section	0.09303
Area of load water plane	15,255 sq. ft.
Displacement to load water line	380,836 cubic
	10,881 tons.
Horizontal distance of center of buoyancy from the submerged stern	225 ft.
Vertical distance of center of buoyancy below load water line	11,456 "
Height of metacenter above center of buoyancy	7,469 "
Height of metacenter above centre of gravity of the ship when fully equipped and loaded	3,458 "
Height of metacenter above center of gravity of the ship at 14 feet draught of water, with no cargo, coal, stores, water, or ballast, and no water in boilers, but otherwise completely fitted and fully rigged	5,060 "
Height of metacenter above centre of gravity of the ship at 9'6 feet draught of water, the hull being complete, with masts in and rigged, but empty, without engines or boilers	11,389 "
Wet surface when immersed to load water line	38,040 "
Angle of obliquity of load water line at the bow	5°50'
Angle of obliquity at the stern	6°30'
Mean angle of obliquity at entrance	7°

The ship is to have two propellers of 26 feet diameter and 28 feet pitch; the propelling power to consist of four compound engines, two on each propeller shaft, developing each, when making 90 revolutions per minute, 4,500 indicated horse power, or for all four engines together 18,000 indicated horse power.

With this power the speed according to Professor Rankine's formula, would be 20.7 knots per hour; but that speed would in all probability be exceeded, as little power will be lost by wave making, the water having a clean run astern, being divided horizontally by the lower part of the hull.

The ship would have room to accommodate about 600 first-class and 1,000 second and third class passengers, and carry 3,000 tons of cargo, besides 2,700 tons of coal, sufficient for 180 hours' run.

The ship is designed to be built of iron or steel, with a double bottom, and with a great number of water-tight compartments, transverse and longitudinal.

The peculiar form of the hull of this vessel makes it possible to unite great carrying capacity with the finest lines for high speeds. The submerged stern, which divides the water horizontally, admits of the finest possible run aft and affords a perfect support and protection to the propeller shafts. With this construction the propellers act constantly in solid water, unaffected by stern post, rudder, and the overhanging part of the stern, as in ships of the usual form. This feature secures an economy of power, or, what is the same thing, an increase of speed.

A vessel of this form will not roll and pitch as much as other vessels, as the body of water above the projecting part of the hull offers considerable resistance to such motions.

The rudders may be nearly balanced, and will require but little power to work them, and on account of the peculiar form of the stern, the rudders may have considerably less area than those of the common model, as it requires less power to move the stern laterally.

The form of the hull, while permitting very sharp entrance and run, affords ample room for the application of the greatest engine power compatible with carrying capacity. Two propellers, acting entirely independent of each other, will increase security against accidents to the machinery at sea, and the same may be said of the two rudders, which, although designed to be worked together by the same steering apparatus, may in case of necessity be worked separately. The arched form of the hull, with projecting sides below water, and the general absence of any plain surface exposed to the sea, admits of great strength of construction, and with suitable watertight compartments the vessel may be made exceedingly strong and safe.

The increasing width of the hull below as well as above the load water line gives great steadiness to the ship, so that it may be moved about even without load or ballast. This is owing to the fact that the metacenter rises with increased beam much more rapidly than the centre of gravity.

The merits of this system are likely soon to be brought to a practical test, and it would be no surprise to those who have given the subject a careful investigation, if the efficiency of the system should prove greater than is indicated by the figures given.

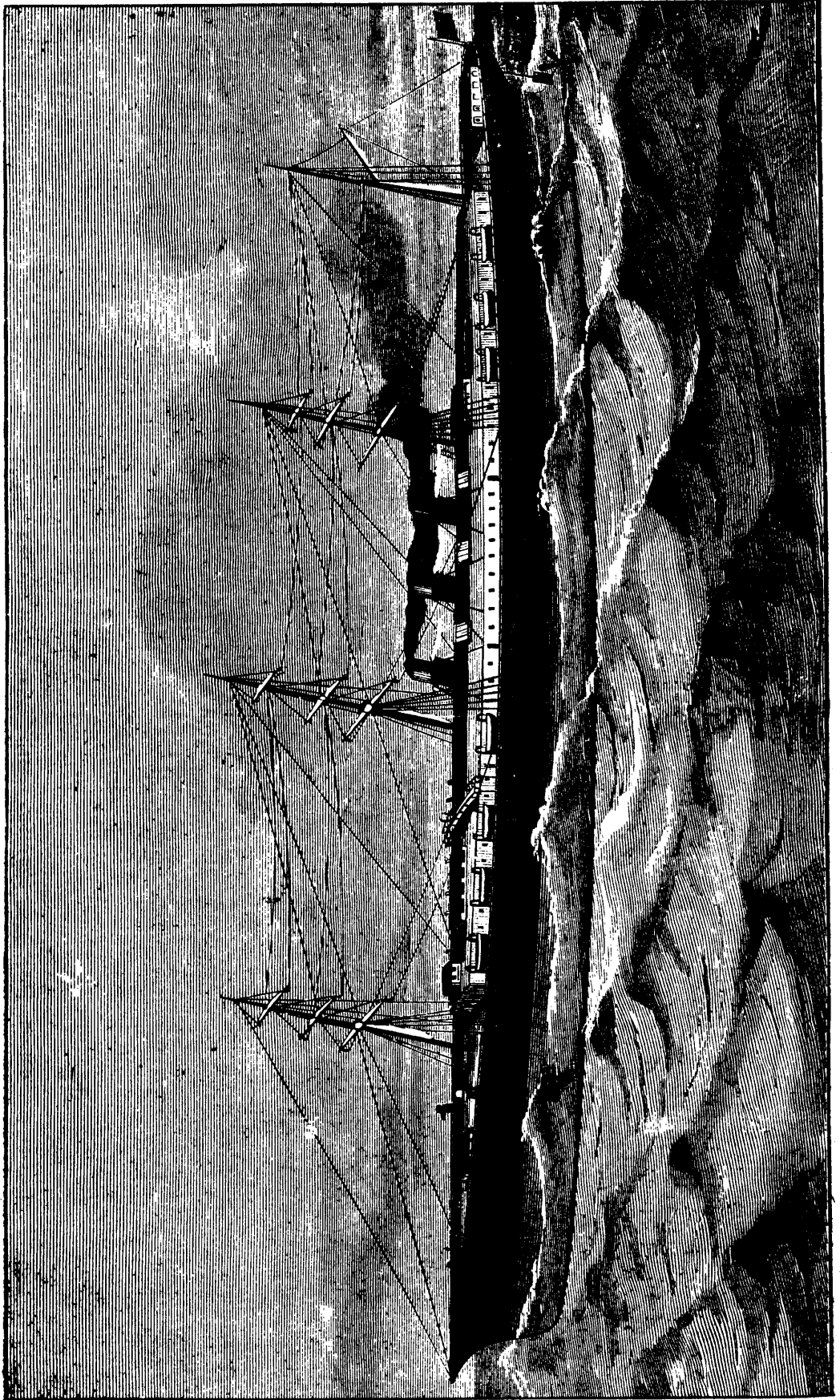

CAPTAIN C. G. LUNDBORG'S FAST OCEAN STEAMSHIP.

PERREAUX'S STEAM TRICYCLE.

We must go back more than two centuries to find the first idea of a steam carriage, and this is due to Isaac Newton, who proposed it in 1680. His system, which was one of the most rudimentary, was nothing else than an aëroplane mounted on wheels. Specimens of it are still to be found as scientific playthings in a few cabinets of physics.

The first tricycle based upon the principle of the steam engine was built by Cugnot, in 1770. To begin with this date, projects have not been wanting, the solutions proposed benefiting each time by the progress of the steam engine applied as a fixed motor. Murdoch in 1784. Symmington in 1786, Reid in 1790, Trevethick in 1802, etc., successively proposed apparatus which to-day are forgotten. In 1804, Evans invented the *oruktor amphibolis*, a sort of boat carriage, the first and last amphibious steam vehicle that has ever been built. We may cite also the steam carriage of Griffiths in 1821, of Gordon in 1822, of Garney in 1828, of Anderson and James in 1829, and of Hancock in 1833.

The latter was the most fortunate of all inventors of such vehicles, since, in 1835, he had not less than three of them in current service, making the trip by steam on the Paddington route. According to Mr. Thurston, Hancock succeeded in constructing a light steam phaeton for his own use, which ran in the city among horses and carriages without interfering with or injuring any one, at an ordinary speed of ten miles per hour, and which could be increased to twenty.

The success of locomotives on rails somewhat diminished the ardor of experimenters in this direction, and, in fact, competitions became impossible for steam street carriages.

To-day the question has assumed a transformation. Owing to narrow gauge locomotives and to tramways in the streets, there are no longer any endeavors to build vehicles designed to supplant horses, but there are still endeavors being made to get up a self-propelling vehicle, convenient and easy to maneuver, designed to receive a small number of persons—one or two at the maximum—and capable of operating regularly for a few hours without demanding too great an amount of attention on the part of the one who drives it.

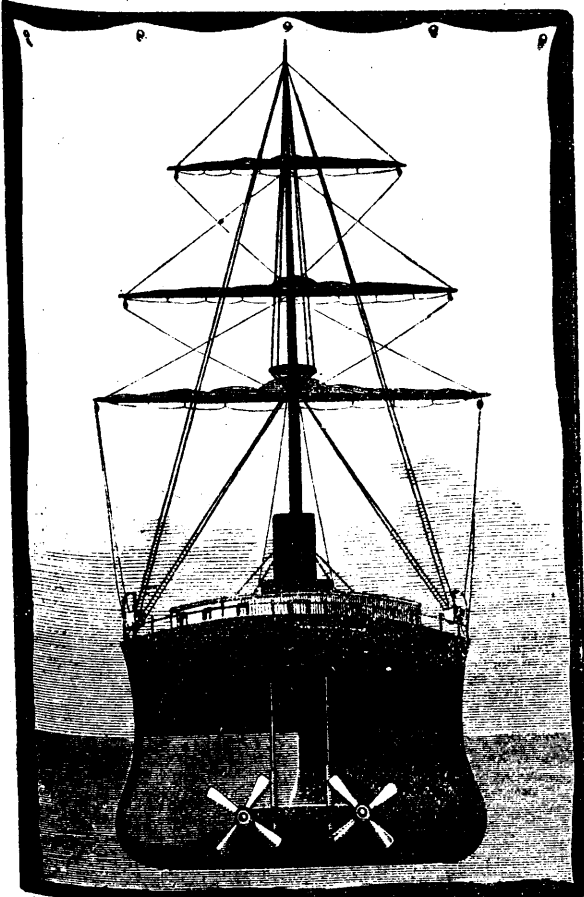

STERN OF CAPTAIN LUNDBORG'S STEAMSHIP.

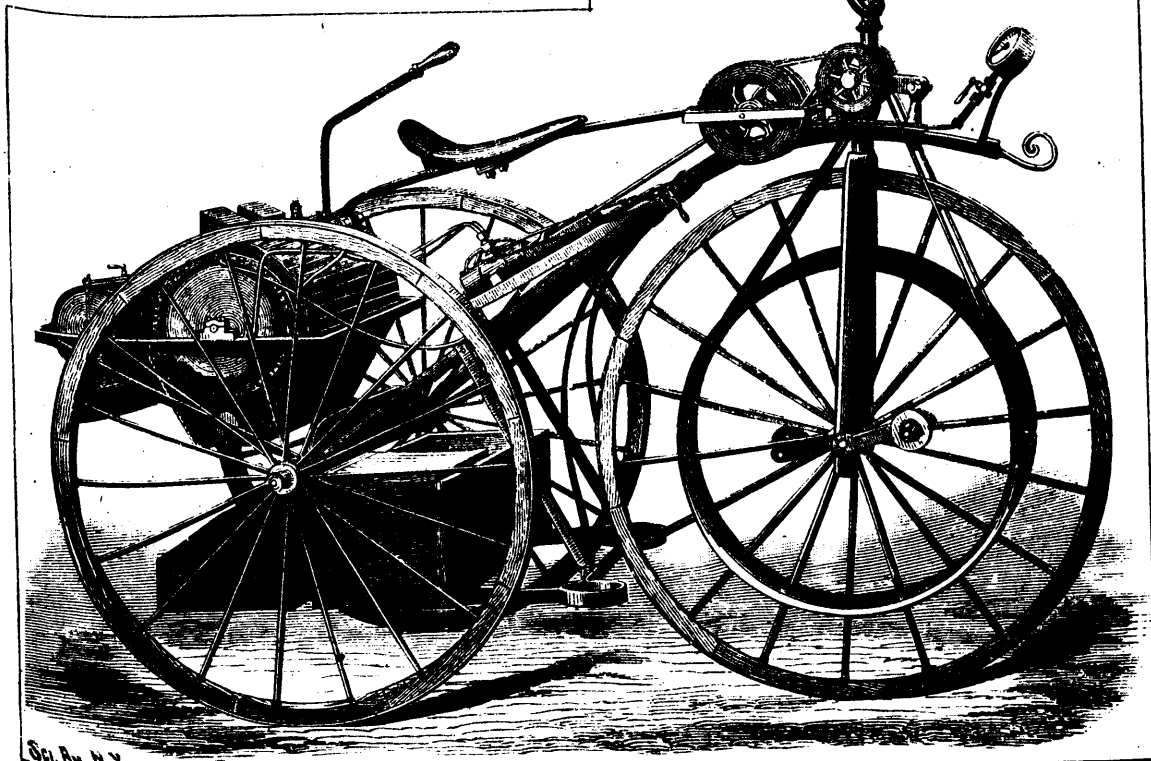

Sci. Am. N.Y.

PERREAUX'S STEAM TRICYCLE.

With this object in view, there have been proposed carbonic acid machines, compressed air motors, and electric motors supplied by piles or accumulators. The few experiments that have been tried in this direction have not as yet given very striking results, but the end is far from having been reached.

Other inventors are continuing their researches in regard to thermic motors, and more especially in regard to steam motors. As one of the most curious of these latter we may call attention to the steam tricycle of Mr L. G. Perreaux, one of our compatriots whose labors are the more worthy of being better known and encouraged from the fact that the inventor has followed up his idea with remarkable perseverance for fourteen years, and has made considerable sacrifices of time and money to perfect his apparatus. Now that his patents are about to become public property, just on the verge of a success that he had hoped for to indemnify him for his outlays, we deem it of interest to briefly describe Mr. Perreaux's system, which by a singular coincidence, presents some analogy to that of Sir Thomas Parkins, than which it is older by several years, since it figured in the Universal Exhibition of Paris in 1878 under a less improved form than that possessed by the present model.

Mr. Perreaux's first experiments were made with an ordinary two-wheeled velocipede carrying the boiler behind the seat of the driver, and the motive mechanism under the seat. It is evident that such a type can only serve for experiments and in a few rare cases. It requires a very peculiar ability on the part of him who manœvers it, and, for this reason it was, in the experiments, fixed to a whim of four meters radius.

In its present form the apparatus is a tricycle whose fore wheel constitutes the motive and steering one, while the hind wheels support the boiler and the greater part of the weight of the driver. The pedals serve for starting the vehicle; for the motive system which is of very small dimensions, would not always do this quickly enough. The boiler, which is tubular, is heated by the vapors of alcohol furnished by a reservoir filled with that fuel, which is itself heated by an alcohol lamp having several wicks. The vaporization of the alcohol which burns under the boiler is regulated by a system of registers, which increases or diminishes the number of lighted wicks, and consequently regulates the production of the boiler according to requirements.

The steam produced by the tubular boiler traverses two copper tubes that are wound about the latter and are in direct contact with the flame. There results for this a production of superheated steam and permits of a better utilization of it and requires for a given work a much less weight of it, thus diminishing the weight of feed water to be carried on the apparatus. This superheating of the steam presents no danger, since it is performed on but a very small quantity at a time, and since the pressure never exceeds four atmospheres, as may be ascertained by the pressure-gauge placed in front of the apparatus. The motive system is a small engine having a single cylinder of 22 millimeters in diameter, and a stroke of 40 to 50 millimeters. Mr. Perreux estimates the work produced by his tricycle at 6 kilogrammeters per second, and that produced by his bicycle at 4 kilogrammeters. The escape of steam takes place under the seat, and the fan is effected by means of a small pump that draws water up into a small reservoir whose capacity is calculated for about a three hours' run without renewal. Motion is transmitted from the motor to the fire wheel by means of cords and pulleys. The driver has within reach all the parts, such as cocks, etc., necessary to operate the apparatus, and can, at will, allow himself to go at an ordinary speed of 12 to 15 kilometers per hour, or else aid the running by working the pedals with his feet so as to increase the speed. All the parts of this interesting little machine are constructed with remarkable ability; and in his last model the inventor has taken advantage of his experience in the introduction of numerous modifications and simplifications which we shall advert to after experiments have been tried with them. The question presents so much interest that we shall not fail to be present at such experiments nor to inform our readers of the results obtained.—*La Nature*.

THE IMPROVED WESTINGHOUSE HIGH-SPEED ENGINE.

We present in the following some additional information respecting the highly ingenious and original form of high-speed engine which we described and illustrated in our issue for May of the current volume. These engines though they have been before the public but for a brief period, have already come into

extensive use for electric lighting, for direct connection to roll trains, for main lines of shafting in shops and factories, and in many situations where economy of space is of importance.

Fig. 1 shows the Westinghouse engine of latest pattern, placed up on a foundation and belted to a main line of shafting.

For the details of the peculiarities of design and general construction of this engine, we will refer to our previous article (*vide* this journal, page 100, current volume). We are interested here chiefly in presenting certain details not noticed in that article, and which are of special interest to mechanical engineers.

First is the arrangement of crank shaft bearings. These are made in the form of removable shells, lined with babbit metal. These shells are tapering, and are fitted to a case. The bearings are babbited upon a steel mandrel, ground so as to exactly fit the journals, so that the skin upon the metal is preserved, thus ensuring better wear. To provide against heating of the journals, by reason of improper adjustment by an inexperienced person, a collar is provided. The end thrust of the shaft is taken by a Damascus bronze collar, while to insure perfect lubrication oil-ways are cut in the face of the journal.

To take up the oil that will flow past the journal, and for which drip pans were provided in the older forms of this engine, an ingenious device in the form of a centrifugal wiper has been introduced, which takes up the oil as it flows into the rear at the bottom by means of its revolving arms, carries it over the bridge at the top, and through a pipe back into the inside of the case, a portion thereof finding its way through a hole provided into the oil cup. No oil can escape through the cover, and the engines are models of cleanliness.

For steam yachts and launches, where cleanliness is a consideration of importance, this feature of these engines will be particularly appreciated; and for this species of service they are especially well adapted, for the reason that they have a low center of gravity.

One of the chief characteristics of these engines lies in the fact that the cylinders do not stand directly over the center line of the crank shaft, but are located to one side, a distance equal to one half the crank radius, which gives a more advantageous action of the connecting rods upon the crank. This fact will be apparent from a study of the diagram (Fig. 2) of rod angles, which will be understood from the following explanation: The heavy line A B represents the center line of the cylinder, and the point C the center of the crank shaft. It being understood that the steam acts only on the downward stroke of this engine, the rod in rising has no work to perform except to raise the piston. The heavy line 1 1 represents the position of the connecting rod at the commencement of the downward stroke, the crank moving in the direction of the arrow. Its extreme angular vibration is shown at 2 2, at which the greatest pressure is exerted upon the crank; while 3 3 indicates the release, or point at which the annular exhaust opens; and 4 4 the position at the end of the stroke. The lighter line, 5 5, 6 6 and 7 7, indicate the various positions of the rod during the up-stroke when the rod performs no work. It is a somewhat curious fact that this engine geometrically speaking has no dead centers.

By this construction, the rod, when working transmits the force with much greater effect to the crank than if the cylinders were central, which would bring the rod at a greater angle. This lessening of the rod angle decreases the lateral thrust of the cranks against their journals as well as that of the piston (which one is one quarter longer than the stroke) against the cylinder, so that the practical result is a great reduction of friction.

Other details of interest are the annular exhaust (described in our previous article), by which back pressure at high speed is wholly avoided; and the perfect balancing of the valve, which is set to cut off at from one-quarter to one third of the stroke, which cannot be done with the ordinary slide valve and a single fixed eccentric. The fly-wheels are turned inside and out, to insure perfect balance. Any leakage of the valve can be discovered by stopping the engine, removing the cover on the valve chest, and turning on steam. All parts of the engine are readily accessible, and the whole design is characterized by extreme simplicity. The makers before sending out an engine, attach it to a boiler and run it for ten consecutive hours under full load, and under a boiler pressure of 90 pounds; it is then taken apart, examined for defects, and the parts are reassembled and put together.

The makers are the Westinghouse Machine Co., of 92 and 94 Liberty street, New York.

ANNULAR ECLIPSE OF THE SUN.

On the 10th of November there will be an annular eclipse of the sun, invisible in this country, but visible in the Southern Pacific Ocean. The path of the eclipse lies wholly in the Pacific Ocean, commencing east a little of the Island of Celebes, including several small islands in the vicinity, the southern part of New Guinea, the whole of New Caledonia, and a few small islands scattered along the route. The rest of the track is over a boundless waste of waters. To observers on these islands, and to those who chance to be on the ocean track at the time, the sun will present the appearance of a dazzling light surrounding the moon's intervening disk. An annular eclipse ranks next to a total eclipse as a spectacle of surpassing beauty, though it is far from being as awe-inspiring or as important to the interests of science.

The difference between total or annular eclipses is easily comprehended. The positions and apparent magnitudes of the sun and moon are constantly varying. When, at new moon, the center of the moon happens to pass directly over the center of the sun; if, at the same time, the sun is at or near his greatest distance from the earth, the apparent diameter of the moon, will exceed that of the sun, and the sun will be entirely hidden from view. There will then be a total eclipse of the sun, visible to observers near the line joining the centers of the sun and moon. These conditions occurred on the 17th of May, when a total solar eclipse took place. The diameter of the sun at that time was $31' 41'' 6''$. The diameter of the moon was $81' 43'' 8''$, exceeding that of the sun $2'' 2''$, sufficient to produce a total eclipse.

When, at new moon, the center of the moon happens to pass directly over the center of the sun; if, at the same time, the sun is at or near his least distance from the earth, and the moon is at or near her greatest distance from the earth, the apparent diameter of the moon will be less than that of the sun, and it is evident that the whole surface of the sun cannot be obscured. There will then be an annular eclipse—called so from the Latin word *annulus*, meaning a ring—which will be visible to observers near the line joining the centers of the sun and moon. Such a combination will occur on the 10th of November. The diameter of the sun will then be $32' 24'' 2''$. The diameter of the moon will be $30' 6'' 6''$, which is $2' 17'' 6''$ less than that of the sun. A narrow ring of light will therefore appear encircling the darkened center.

The present year numbers but two eclipses on its annals. There have been no eclipses of the moon, and the two solar eclipses are those to which we have referred. But the rare event of the transit of Venus, which will take place on the 6th of December, deserves to be numbered with the solar eclipses, for it is due to a similar cause. The planet obscures as much of the solar disk as she is capable of doing, when she passes like a black point over his disk. If she were as near as the moon she would cause an eclipse of the sun that would last long enough to be of great assistance in the solution of many vexed problems concerning solar physics.

If the eclipses of the year are few in quantity they make up for the deficiency in their excellent quality.

A total solar eclipse, an annular eclipse and a transit of Venus are seldom the sole records on the annals of a single year. It is much to be regretted that the path of the coming annular eclipse falls upon a portion of the world where there will be few to look upon the superb spectacle when the moon hides the sun's face with the exception of a narrow ring of dazzling light.

DARK BODIES IN THE SOLAR SYSTEM.—Sir John Lubbock's opinion endorses the conclusion long since put forth by some of the most eminent astronomers—namely, that there are now in the solar system, or firmament, many dark bodies—that is, bodies which now emit no light, or comparatively little. He points out, for example, that in the case of Procyon, the existence of an invisible body is demonstrated by the movement of the visible star. Another illustration which he cites relates to the notable phenomena presented by Algol, the bright star in the Head of Medusa. This star shines without change for two days and thirteen hours; then, in three hours and a half, dwindles from a star of the second to one of the fourth magnitude; and then, in another three and a half hours, re-assumes its original brilliancy. According to the view entertained by Prof. Lubbock, these changes must be regarded as indicating the presence of an opaque body, which intercepts at regular intervals a part of the light emitted by Algol.

Scientific.

A FUEL THAT PRODUCES ELECTRICITY.

The object which Mr. Brard, of La Rochelle, has in view in his researches is to produce an apparatus capable of transforming heat into electricity without having recourse to the complications presented by dynamo-electric machines which have been hitherto inapplicable for domestic illumination. Mr. Brard wishes to produce a veritable electro-generative stove, furnishing at the same time heat, light, and electricity. After having demonstrated by his experiment that thermo-electric batteries have on one hand only a feeble production, and on the other hand are soon rendered useless under the action of heat, Mr. Brard thinks he has found, according to the *Electrical Review*, the solution of the difficulty in a thermo-chemical battery, in which the current is produced by chemical action, the combustion of carbon, under the influence of an elevated temperature produced by a special method, by the oxidizing action of nitrate of potash or soda. It forms thus a veritable thermo-chemical battery, analogous to the ordinary batteries, in which the oxidizing of the carbon takes the place of the oxidizing of the zinc, and the nitrate of potash of the oxidizing body. The carbon, is, therefore, the negative pole, and the nitrate the positive pole of the element.

M. Brard alluded, in reference to his labors, to the experiments of Antoine-César Becquerel in 1855, and those more recently made by M. Paul Jablochkoff in 1877; he has, however gone further than his antecedents in this way, for he has presented to the association the principal features of an apparatus actually in construction, and showed some electro-generative slabs which we are about to describe, reserving the description of the complete generator until it has been tried, and until it has undergone certain modifications which the experiments will suggest.

Electro-generative Slab.—The electro-generative slab may be defined as a piece of prepared carbon, which, when thrown into the fire, produces electricity by its combustion. The subjoined figures which represent the exterior view of it, the longitudinal section, and the transverse section, will demonstrate clearly the principle of it.

The slab presents the external appearance of a parallelepiped about 15 centimeters (6 inches) long, $3\frac{1}{2}$ centimeters, (2 1-6 inches) wide, and 25 millimeters (1 inch) thick: the materials which compose it are enveloped in a sheet of asbestos paper, only two thin sheets of brass being exposed to view, which serve as conductors of the current. The interior consists theoretically of a prism of carbon and a prism of nitrate of potash, separated by a plate of asbestos, which plays very nearly the same part as the porous cell in ordinary batteries. In practice the sheet of carbon is formed of about 100 grammes of coal-dust, formed into a paste with molasses or tar. The paste thus obtained is strongly compressed, cold or preferably with heat, in a mould of suitable form, at the bottom of which has been placed previously a sheet of copper, of brass, or any other metal which is a good conductor, cut into several strips, which are found embedded in the agglomeration of the carbon and project from one of its extremities to constitute the negative pole. The mould is disposed in such a manner that the slab is perforated throughout its thickness with numerous holes intended to facilitate combustion and to multiply the points of contact of the carbon with the nitrate, as we shall presently see. It bears besides upon the upper surface rectangular depressions, 15 millimeters deep, divided by transversal partitions more or less numerous, obtained by the moulding. The angles thus formed are intended to prevent the flowing of the melted nitrate into the fire during the working of the apparatus. The whole surface of these compartments is covered by a thin sheet of asbestos paper. The upper part of the brick is formed of a mixture of three parts of ashes and one part of nitrate of soda or potash. The ashes are intended to prevent a too rapid combustion, and to prevent the slab from melting. This mixture is melted and poured upon the brick very hot and in a sirupy state. About 100 grammes per slab are required, equal to about 25 grammes of nitrate and 75 grammes of ashes. A second sheet of copper or brass analogous to the first is embedded in the nitrate before cooling, and forms the second pole of the slab. The whole is enveloped in a sheet of asbestos paper.

It is sufficient to place in a fire the extremity of the slab opposite to the conductors, in order to obtain in a few minutes a

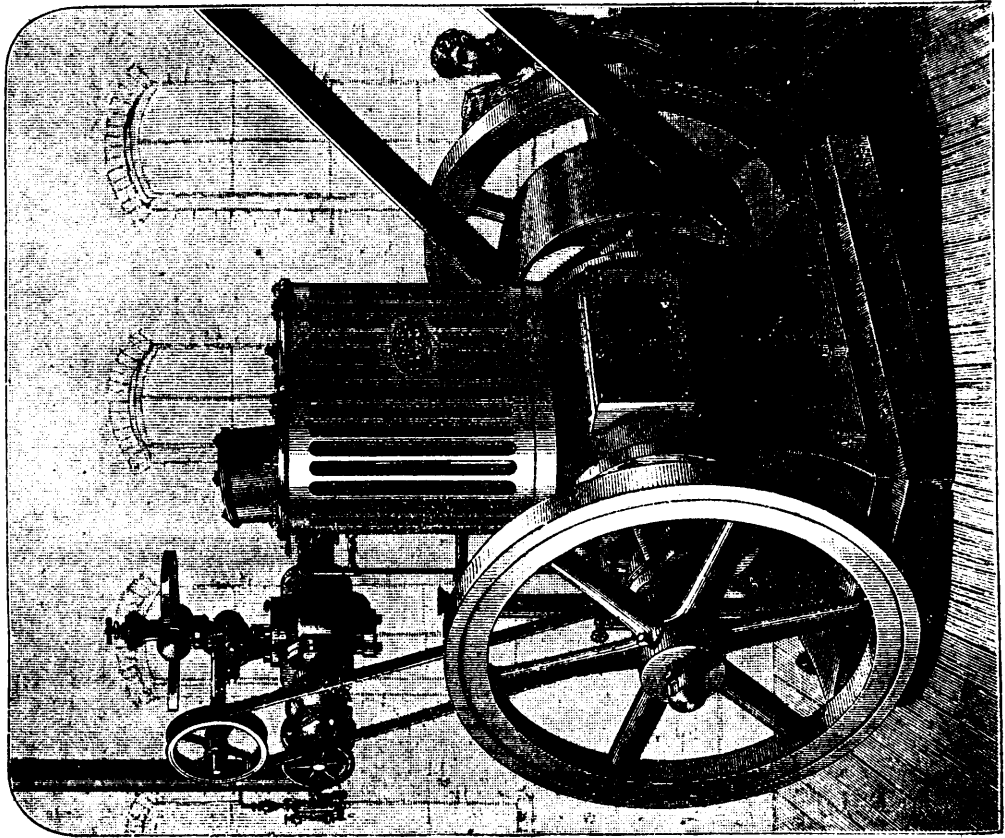

FIG. 1.—THE IMPROVED WESTINGHOUSE HIGH-SPEED ENGINE.

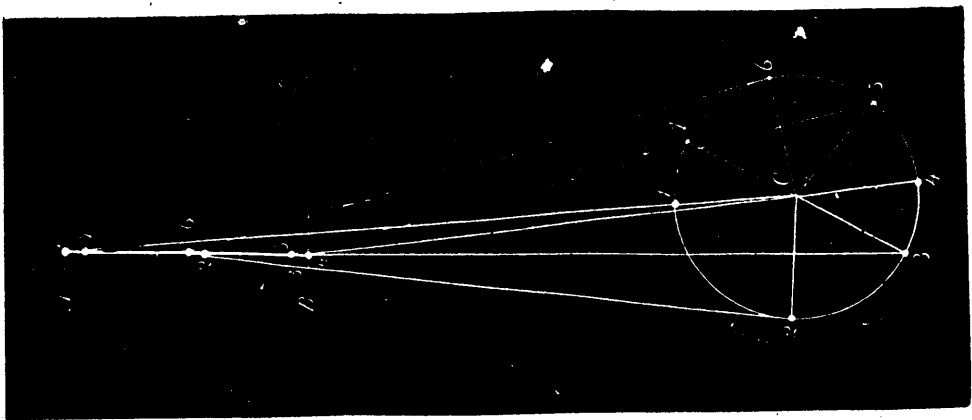
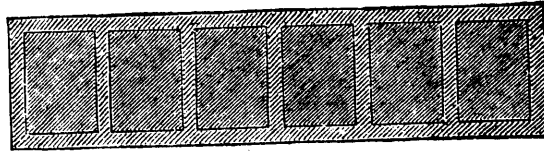
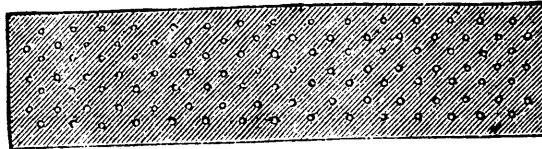

FIG. 2.—DIAGRAM OF ROD ANGLES.



TOP VIEW.



UNDERNEATH VIEW.

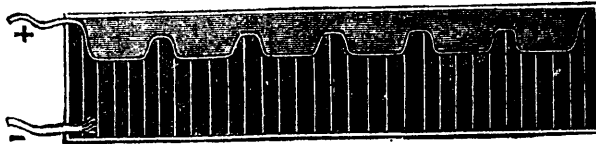

LONGITUDINAL SECTION.

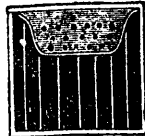

TRANSVERSE SECTION.

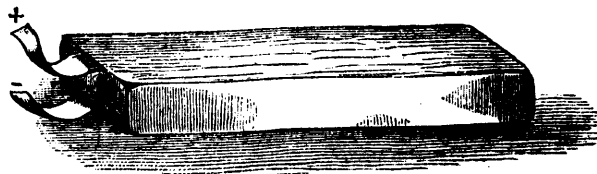

GENERAL VIEW OF SLAB.

continuous current—and a constant one if the slab is homogeneous—during its combustion, lasting an hour and a half to two hours. M. Brard has not yet taken the constants of this new thermo-chemical battery, but in an experiment which we owe to the chemical department of the laboratory of the Lycée of De Rochelle, a single slab was sufficient to actuate an electric bell of the ordinary commercial form. One can, moreover, burn several briquettes at once, and group them in tension or in quantity to increase the effect. Three or four slabs in tension produce the decomposition of water.

Such are the results at present obtained by M. Brard. Without expressing an opinion as to the future and the results which will be obtained from this apparatus, which is at present confined to the laboratory, we may observe that these researches are very interesting, and that to M. Brard must be ascribed the honor of having been the first to construct a veritable electro-generative combustible.—*Scientific American.*

ELECTRIC LIGHTING IN NEW YORK.

The experiment of introducing the incandescent electric light, which Mr. Edison's company is about attempting on a large scale in a district of this city, will be watched with more than common interest. It will be by far the largest trial of electricity as a competitor of gas for domestic lighting that has yet been tried, and on the success or failure of the experiment the fate of the electric light, for the immediate future at least, is ultimately bound up.

Mr. Edison has earned a world wide renown, and justly, as a most ingenious and daring inventor; he has command of ample resources, and enjoys to an eminent degree the confidence of the community. These are important and powerful aids in his present ambitious venture, which we sincerely trust may justify the confident expectations of himself and his associates.

There are many conditions, however, aside from that of cheapness, that the incandescent light must fulfill to meet the requirements of domestic lighting. Of these the most important perhaps is that of its reliability. It must demonstrate itself to be as reliable as gas, to take its place. There must be no failure of the lights from derangement of electrical connections, or other accidental causes, for a few such failures would be fatal to its popularity. It must be as manageable as gas, and the fixtures by which it is controlled must be free from complications and readily manageable. If these requirements are satisfactorily met, we are satisfied that the question of cost—within certain limits, of course—will be a secondary consideration. The incandescent light possesses so many advantages over gas light, that people will readily pay more for it than for gas light. It (the electric light) gives a clear and steady illumination, it gives out no noxious gases, and does not impoverish the air of a room as gas light does, and it evolves much less heat than gas. For these reasons its superiority as a means of illumination is obvious.

Mr. Edison and his associates propose to furnish their light at a very moderate cost, and it is to be presumed that, being engaged in an extensive business operation, they know what they can afford to do to yield themselves a fair profit on their investment. The whole question of the availability of electricity as a means of domestic lighting promises, therefore, to be determined in the immediate future.

While we do not contemplate the failure of this interesting experiment, we hold the opinion that the system of electric lighting that will ultimately prove most satisfactory from an economical standpoint, and that will find the most general adoption, will not be based upon the plan of distribution from one great central source of power, as is the case in the system here under consideration; but, on the contrary, will involve the employment of portable secondary batteries, which will be charged with a sufficient supply of electrical energy at the central station to supply a number of lights for a certain period—say a month. Each consumer in a district (whose house is furnished with proper fixtures) would then be visited by the company's agent at stated intervals, who would remove the exhausted battery and leave a freshly charged one in its place. Before this plan can be introduced, however, it will require material improvements to be made in the construction of batteries of this class; but so much has been already accomplished that the prospects of further and radical advances in the direction indicated are very hopeful.

Whether he shall be successful or not, however, Mr. Edison's magnificent daring and energy must command the highest admiration. The public is warmly interested in his success, and it is not extravagant to declare that should such prove to be the outcome of his enterprise, as we trust it may, he will add to his well-earned honors as a distinguished inventor the distinction of being also a public benefactor, in having paved the way for what would be justly entitled to be called a real advance in civilization.

THE RELATIVE MERITS OF ELECTRIC LIGHTING AND GAS LIGHTING.

The distinguished president of the British Association (Dr. Siemens), in his recent presidential address, made some interesting comparisons between gas and electricity for illumination, with special reference to the future field of these agents, which are of special value at the present time when the subject is attracting so much of public attention.

Dr. Siemens expressed the opinion that the electric light could not supersede gas as an economical means of illumination. Gas he called "the poor man's friend." "Gas," he explained, "is an institution of the greatest value to the artisan; it requires hardly any attention, is supplied upon regulated terms, and gives with what should be a cheerful light, a genial warmth, which often saves the lighting of a fire."

Gas, therefore, has advantages which apparently can never be overcome by electricity. Even assuming the cost of the electric light to be practically the same as that of gas, the preference for one or the other will in each application be decided on the grounds of relative convenience; but gas, he seems to think, must always be more generally adapted to the wants of the public. Moreover, electric competition is leading to technical progress both in cheapening the cost of production and increasing the purity and illuminating power of gas; and improved burners, rivaling the electric light in brilliancy, greet our eyes as we pass along our principal thoroughfares.

As Dr. Siemens says, "it can no longer be a matter of reasonable doubt that the electric light will take its place as a public illuminant;" and he holds that even if it shall be found more costly than gas, it will be preferred for certain uses, such as lighting drawing-rooms and dining-rooms, theaters and concert-rooms, museums, churches, warehouses, show-rooms, printing establishments, factories, and also the cabins and engine rooms of passenger steamers.

Whether electricity can be so sent from central stations over a large area to thousands of lamps that it shall be as unfailling as gas light, and as business necessities and domestic conveniences requires that it shall be, is yet to be determined.

VALUE OF VIVISECTION.—Mr. G. F. Yeo, a Fellow of the Royal Chemical Society, and Professor of Physiology in King's College, lately delivered a remarkable lecture before the Royal College of Surgeons which was devoted to a *résumé* of the benefits to humanity and to scientific surgery and medicine derived from experiments upon living animals, usually called "vivisection," against which, owing to the clamor of ignorant sentimentalists, stringent and ridiculous laws have been enacted in the United Kingdom.

The lecturer presented a great number of illustrations to prove the inestimable value to suffering humanity of experiments conducted on living animals, of which, however, we have only space to select one by way of a striking illustration.

There are many operations which have been performed on the stomach, and the other abdominal viscera, which are the outcome of vivisection. Thirty years ago Sedillot was tempted by the facility with which Blondlot established gastric fistula in dogs, for the purpose of making experiments in digestion to perform a similar operation on a human being. Having under his care a cancer of the œsophagus, in which life was threatened from inanition, he determined to open the stomach. He did so successfully, and with excellent results to the patient. Since then Billroth has removed a portion of the stomach for cancer, and Czerny has removed a cancerous tumor involving the pylorus of a patient, who was rapidly sinking from occlusion of outlet of the stomach and constant vomiting. In the last remarkable case the patient rapidly recovered, and resumed his usual occupation in little more than a month. A similar case treated with equal success, is that of a robust young girl who had so seriously injured the œsophagus by reason of having swallowed by mistake, a corrosive poison, that it was nearly impossible to introduce food into the stomach, either by natural or artificial means, and death by slow starvation was imminent.

By experiments on dogs it was ascertained that by securing the union of the serous surfaces, a portion of the intestine could be removed and the ends of the remaining portion sewn together so that the peritoneal surfaces united. This fact has since frequently been successfully made use of in treating the human patient, and many wounds or diseases involving the intestines, which were formerly invariably fatal, have been cured.

These examples, which we might multiply indefinitely from Yeo's most instructive lecture, are sufficient of themselves to refute the extravagant statement of the anti-vivisectionists, that "not one benefit has accrued from the labors of the physiologist, either to medical or surgical science," and to demonstrate the ignorance and folly of their unreasoning and sentimental crusade against scientific experiments upon living animals in the interest of humanity.

Scientific Items.

AN ELECTRIC ARC REGULATOR, which the inventors, MM. Clerc and Bureau, of Brussels call, the "sun lamp" (*La Lampe Soleil*), and which was an acceptable illuminant of the picture gallery at the late Electrical Exhibition in Paris, is now employed in the foyer of the Grand Opera House of the same city, and has latterly been received with favor in the vaults of the Royal Exchange, London. It is as ugly as may be, whatever may be its other properties. Two holes are bored in a square block of marble or dry limestone, so that they slant toward each other and nearly meet at the base of the block. The carbons are inserted in these holes, and the current traversing them raises the partition of calcareous substance to incandescence. All accounts agree in stating that the light is soft, white and steady.

POISONOUS COLORING MATTERS IN FOOD.—In France, where more decisive and summary methods of dealing with the adulteration of articles of food and drink are the fashion than here, a very sensible order has been issued by the Prefect of Police in Paris, forbidding the use of any of the following substances for coloring sweetmeats, liquors and foods: *Mineral Colors.*—The compounds of copper—blue verdigris, mountain blue; compounds of lead—oxides of lead, massicot and minium, oxychloride of lead, Cassel yellow, Turkish yellow, Paris yellow, carbonate of lead, lead white, antimoniate of lead, Naples yellow, sulphate of lead, chromates of lead, chrome yellow, Cologne yellow, chromate of baryta, compounds of arsenic—arsenite of copper, Scheele's green, sulphide of mercury, vermilion. *Organic Colors.*—Gamboge and Naples aconite; fuchsine and its sub-products, such as Lyons blue, eosine; nitro-derivatives, such as naphthaline yellow and Victoria yellow.

The restrictions against the use of these substances in food products extends likewise to the coloring of wrapping papers for containing any kind of food; and manufacturers and dealers will be held responsible for any accidents that may occur through neglect or disobedience of the prohibition.

ETHER VAPOR AS A SUBSTITUTE FOR HYDROGEN WITH THE OXYHYDROGEN LIGHT.—Mr. Ives, of Philadelphia, has devised an ingenious arrangement, at once simple, compact and effective, for dispensing with the use of hydrogen or illuminating gas in using the oxyhydrogen jet for lantern demonstrations. His apparatus consists of a cylinder of brass about 10 or 12 inches in length, and capable of holding about a pint of ether. The cylinder is supported horizontally on a base, so that it may be placed conveniently near to the operator. It is filled with some porous substance capable of absorbing the ether, and then charged with the liquid. The cylinder is provided with suitable inlet and outlet tubes, controlled by stop-cocks. The oxygen is admitted to the cylinder, and, passing through the saturated porous mass contained therein, loads itself with ether vapor, and in issuing from the jet burns with a small but intensely hot flame, which, directed upon a block of lime in the usual way, gives a brilliant light which compares favorably with that obtained in the usual manner with hydrogen or burning gas. The portability and convenience of the apparatus will commend it to the favor of exhibitors and lecturers.

TRANSPLANTING LIVING TISSUE.—An interesting surgical operation is reported to have been made recently by Dr. H. L. Little at the Hospital of Jefferson College, Philadelphia. It consisted of the removal of a portion of the conjunctive of the eye of a live rabbit to that of a young man who had been badly injured with sulphuric acid. The surgeon removed the eye-lid from its firm adhesion to the eye-ball, and made it ready for receiving the new piece of membrane, which his assistants had meantime carefully dissected from the eye of the unconscious rabbit. The part was rapidly transferred to the under surface of the patient's eye-lid and neatly stitched in place. The operation is reported to have proved entirely successful. Here is a chance for the anti-vivisectionists to express their horror of the barbarities of modern science. The young man's eye may be restored to sight, but think of poor "bunny!"

M. JACQUES, of Paris, has invented a new process of preserving wood. He first impregnates the timber thoroughly with a simple solution of soap mixed with an acid—preferably phenic acid. This causes the fermentation, in a few days within the wood, of a fatty acid, which is insoluble in water, and impregnates the remotest fibres. The reaction of the acid on the soap does not take place until a portion of the water has evaporated. It is claimed that more perfect impregnation can be had in this way than with creosote, and there is no danger of the washing out of the preservative from the exposed surfaces, as when sulphate of copper is used. The government commission on technical railroad operation in France is said to favour this process.

STENCILLING.—For stencilling on distemper colour, mix up the dry colours in a vehicle compounded of one-third of Japan gold-size and two-thirds turps, care being taken that no oil gets among the colour, as it would cause an oil mark to "strike." By using this paint for stencilling on a distemper ground the work can be done clean and rapid, as the Japan colour will not "clog" the stencil as does size colour, thereby saving a lot of work in cleaning the stencil plates. This vehicle is also the best one to use for lettering holland, shop or office blinds, as by using it the unsightly oil marks often seen around the lettering are avoided.

Sanitary and Plumbing.

SANITARY ARRANGEMENTS IN THE RESIDENCE OF MR. CORNELIUS VANDERBILT.

The water supply apparatus in the house of Mr. Cornelius Vanderbilt is marked by its extensive, elegant, and substantial character.

The water supply, the distribution of which we shall first describe, is partly from Fifty-seventh street on which the house fronts, and partly from Fifty-eighth street, to which the lot extends in the rear. That from the former will be through a 3-inch iron pipe. Just inside the house wall, in the cellar, it will enter a meter, from which a 3-inch brass pipe will run to the pumps and a 2-inch pipe to a distributing reservoir. The tank pump will be run by a hot air engine, and force the water through a 2-inch brass pipe to the tank on the fifth floor just under the roof. A sketch of this tank and its connecting pipes will be seen below on this page. It is a closed tank of about 1,300 gallons capacity below the overflow, made of riveted plates of wrought iron. It rests on wooden beams raised about an inch above the surface of the lead safe, A, by small blocks of wood covered with lead. Grooves in the safe converge to an outlet, B, to remove the water of condensation. This outlet is connected with a 1½-inch brass pipe, C, to be discharged over the lower elevator tank or over a sink. The 2-inch brass supply pipe, D, coming up on the other side of the bowling alley which occupies the centre of this floor, is carried over the ceiling and down into the tank as shown. A half inch branch, E, taken from it above the ceiling, will supply the deep trap on the 4-inch iron overflow, F, which is connected with the sewer. The 2-inch iron vent pipe, G, runs out through the roof. The side of the tank is broken away to show the copper float, H, which slides up and down on the pipe rods, being connected by a brass sash chain, running over the ceiling in a wooden trough on pulleys and down through a brass pipe to an indicator in the engineer's room. A manhole at K, gives access to the interior of the tank. The down supply from the tank is through the 1½-inch brass pipe, L, passing through the lead-lined and lead-covered trough, M, through which the two three-quarter inch relief pipes, N, N, from the hot water reservoirs, also pass. The lead-lined trough has a waste outlet like safes under fixtures. In all cases horizontal pipes under floor are carried in this, but the whole amount of such piping is very small, the fixtures above the basement being arranged in tiers, one above another. From the point where the supply pipe, L, turns down, a 1½-inch air pipe, O, is returned to the tank, to prevent "air binding." The 1½ brass pipe, P, discharging into the overflow, is for emptying the tank. A self-closing faucet, R, is inserted in the end of the tank for drawing water for use on that floor, there being no other tap; beneath it is a wooden rack on which to rest a pail.

Returning to the Fifty-seventh street meter, the distributing reservoir before mentioned will be a vertical iron cylinder about 5 feet high by 15 inches in diameter. The 2-inch supply from the meter will enter the bottom (from which also will be taken a 1-inch sediment pipe), and six distributing pipes leave one side, between a point 4 inches from the bottom and the middle—the upper part to serve as an air cushion. One 1½-inch branch will supply the fixtures of the kitchen which is in the front of the basement, passing on its way to them around the grease traps under the sinks, as will afterwards be described. Another 1½-inch branch goes up through the house to the third floor to supply bath room fixtures. The four other branches will be each 1¼ inches in diameter. One will supply the street washers, the fixtures in the front basement, and the steam heating boilers; another the fixtures in the cellar; another the slop sinks; and the last, two fountains.

The supply from Fifty-eighth street is through a 1½-inch lead pipe. This also will pass through a meter, after which it will enter a vertical lead cylinder, 4 inches in diameter, similar to the larger one of iron and for the same purpose. One 1-inch lead branch will supply a fountain and street washer, and a 1½-inch brass pipe the fixtures of the laundry, which is in the rear of the basement. Before reaching any fixtures, this latter branch passes through about one hundred feet of brass pipe in the drying room adjoining the laundry. This is arranged in twelve horizontal lines, one above another, and connected by bends, like some forms of steam radiators, and has a drip trough below it; it is designed to condense and remove the moisture from the drying room.

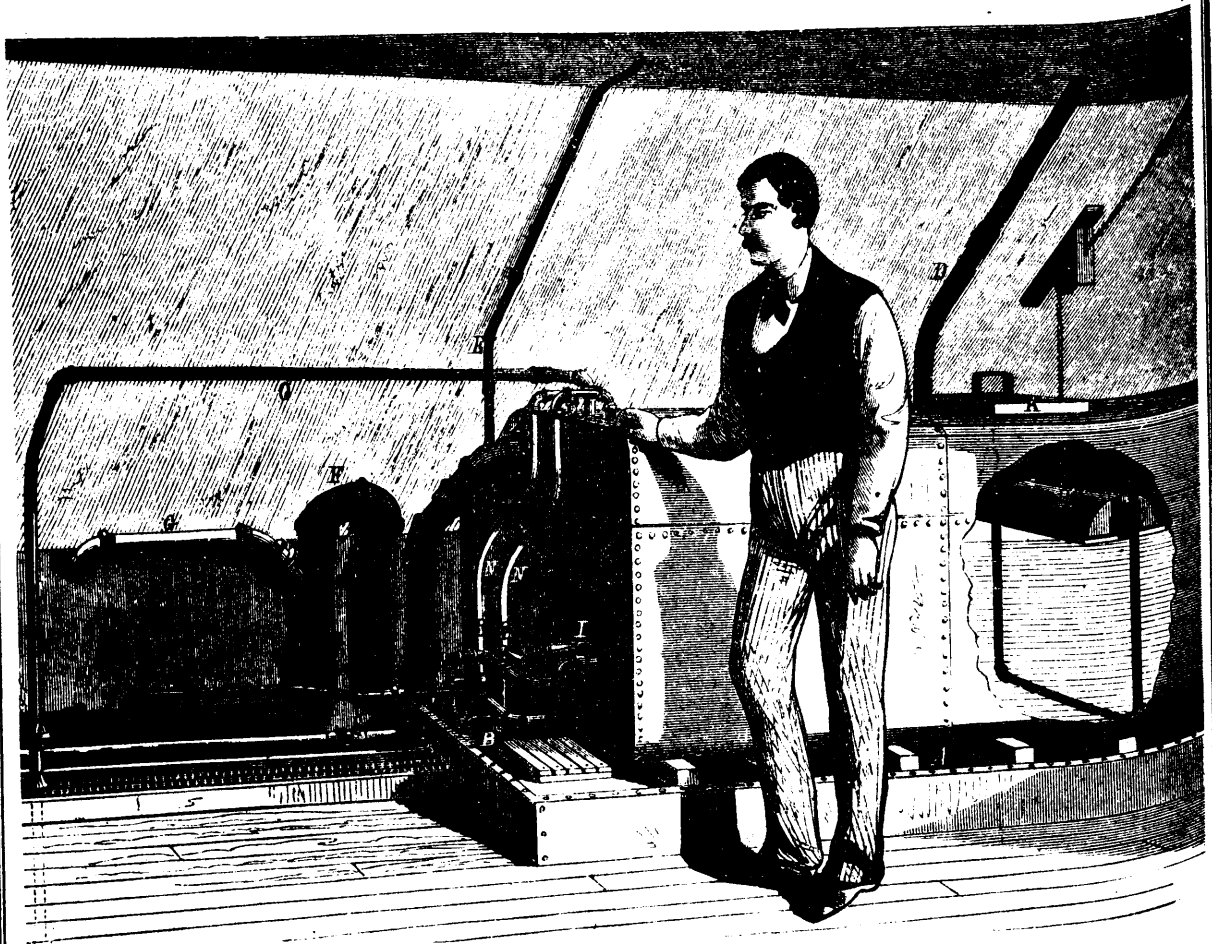

TANKS AND CONNECTING PIPES IN THE RESIDENCE OF MR. CORNELIUS VANDERBILT.

These two supplies from the different streets may be connected with each other by opening a stop cock. The two hot water supplies—kitchen and laundry—may also be connected. These will be described in detail after the boilers and ranges are set and connected.

The method of distributing to the bath rooms is as follows : As before stated, these fixtures are arranged one above the other. In a passage way to the bath room on the second floor, three sets of three pipes each came through the floor beside the wall ; one set is for cold water, another for hot water from the kitchen boiler supplied from the tank, and the third from the kitchen boiler supplied from the street pressure. The outside pipes of each set (being, respectively, the street pressure cold and the tank cold ; the tank hot and its return circulation ; and the street pressure hot and its return circulation) are connected with each other about three feet above the floor, and from the middle of this connection, having a stop cock on each side, the third pipe of each set is taken to supply the bath room fixtures directly opposite, the middle pipes being the distributors of cold—either tank or street pressure—tank hot and street pressure hot—to that floor, and going no higher. The two hot water pipes also are connected, so that either source of hot may be drawn from as well as either cold. The same method is repeated on the floor above, but the street pressure pipes (except the boiler circulation pipe, which is extended to the tank for relief) go no higher. All the water supply pipe in the house is of brass, tinned outside and inside, and all in sight above the cellar is nickel-plated.—*Scientific American.*

Trade Industries.

MACHINE FOR FIXING THE THREADS OF FABRICS.

The machine shown in the accompanying engraving is designed to effect one of the principal operations that have to be performed before the dyeing and finishing of cashmere merinos. The object of fixing is to render staple each filament composing the fabric, so as to keep the threads of the warp, like those of the wool, in the position that has been given them in weaving, and to prepare them to undergo the successive operation without the fabrics fraying or breaking. It is a moist finishing performed at a temperature equal to that which the fabrics will again have to withstand. In weaving, the threads of the wool, in crossing those of the warp, assume a wavy form that results solely from the tension that the latter have received. If a thread of the wool be removed from the fabric it will imperceptibly tend to assume its original form. It results from this that if the operations of dyeing were proceeded with before the fabric had been submitted to fixing, the wool threads would become easily displaced and form frays. In the second place, as manufacturers of fabrics size the warp threads so as to give them greater firmness, it is necessary before proceeding to the fixing to remove this dressing, which exists in the proportion of 8 to 10 per cent. and which dissolves in water raised to a temperature of 40° to 50°.

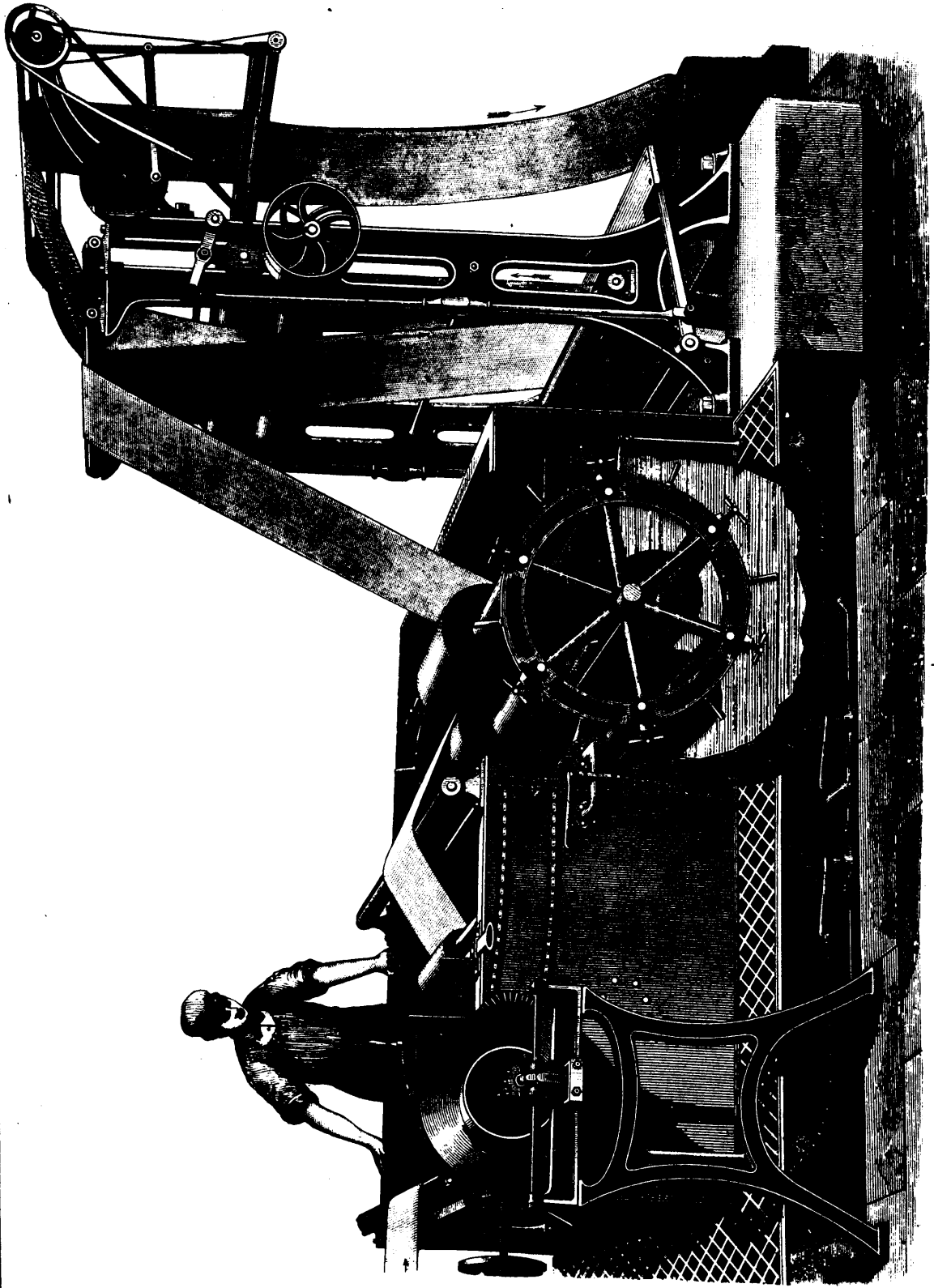

MACHINE FOR FIXING THE THREADS OF FABRICS.

Fixing, then, consists of two very distinct operations: (1) the removal of the sizing, which is done with water heated to 40° or 50°; and (2) fixing, properly so-called, which is performed with water raised in this case to a temperature varying between 70° and 80°.

The new machine under consideration permits of performing the work continuously and of obtaining a uniform treatment of the fabrics as well as a complete fixing of all the fibers. It advantageously replaces those old manipulations that were attended with a great expense, due to the manual labor required; for the results there all depended upon the surveillance and intelligence of the workmen.

The machine consists of two roll vats, each containing a rotary apparatus that carries rollers designed for receiving the woven pieces. The first vat, which serves for unsizing, is heated to the temperature requisite for dissolving the dressing and gelatine with which the warp threads had been sized. The liquid contained in this vat is quite quickly saturated, and is renewed twice a day. One of the lower cocks serves for emptying the first vat, which is afterward partially filled with liquid from the other one. This transfer of liquid is effected by means of a connecting pipe placed between the two tanks. The remainder of the filling of the first vat is done with ordinary water, to which has been added carbonate of soda to soften it. The water in the second vat is likewise heated to the temperature indicated above; and it is in this vat that the fixing is actually effected.

The rotary apparatus in each vat consists of two wheels mounted upon a common axle, and carrying between them at their periphery, six rollers for receiving the fabrics. Each of these latter, on winding on the roller arranged for it, passes through a device designed to keep it taut and regular. As soon as one roller is entirely surrounded, the large wheels are caused to move forward a sixth of their circumference by means of handles, thus carrying the full roller into the liquid and presenting an empty one to be wound.

Each of these rollers is furnished at its extremities with small screw-brakes, which prevent the rotation of the axles during the immersion of the fabric in the liquid, and which give a certain tension to the fabric when it is passing from the first into the second vat, or from the latter to the squeezer. Rotary motion is transmitted to the receiving roller by means of a driving gear, acting progressively, and of a coupling sleeve. These mechanisms also actuate the roller of the second vat, through the medium of an endless chain.

On leaving the first vat, to pass into the second, the fabric passes over a guide-roller, for which there may be substituted a widening bar or a stretching cylinder.

A maneuver similar to the preceding is performed in the second operation; so that, counting five minutes for the winding of a piece, the latter afterward remains for thirty minutes in each of the vats, before being carried toward the squeezer.

The rollers are arranged for the reception of two pieces of goods of 100 meters each in length, but experience has shown that it is preferable to treat but one piece at a time. In this way there are prevented any irregularities that might otherwise occur in the selvages.

On its exit from the second vat, each piece descends into a reservoir containing tepid water, and afterward passes between the squeezing rollers of the drying apparatus. One of these rollers has a copper surface and the other is covered with India-rubber. The requisite amount of pressure is given them by means of a pedal at the base, connected by levers with the parts above. It varies according to the nature of the fabrics and the degree of dryness that it is desired to obtain.

When the first piece begins to leave the squeezers, the operation proceeds afterward in a continuous manner. Thus, during the winding of a piece over the roller located in front, the back roller unwinds, and its fabric then winds about the first roller of the next tank. At the same time, the fabric on the very last roller disengages itself, passes into the reservoir of tepid water, and then goes to the squeezing apparatus.

The mechanical movement of the folding machine draws the fabric on to the table, where it is properly arranged in folds, and from whence it is next taken to undergo the operations of scouring, rinsing, mordanting, and dyeing.

The same machine, arranged with perforated rollers and a pump for the circulation of liquid through the fabric, serves likewise for the ungumming of silks and the rinsing and scouring of cotton and woollen fabrics.—*Revue Industrielle.*

Chemistry, Physics, Technology.

NEW METHOD OF PRINTING PHOTOGRAPH IN COLORS.

The Hoeschotype is the invention of Herr F. C. Hoesch of Nuremberg, who has spent the last three years in bringing his process to perfection. The method by which Herr Hoesch works is at once simple and rapid. A photograph is first taken of the picture. From the negative six gelatine prints on glass are made, and a color plan having been made on one, on each of the other five a separate color scheme is worked out corresponding to the particular tint desired, all the portions not required being painted out. The colors used are three primaries, a neutral gray, and a brown, and with these five tints any combination can be produced. The gelatine is made insoluble by bichromate of potash, and thus can be printed from in an ordinary lithographic press. The advantage which Herr Hoesch claims is that where a chromo lithograph of an extended scale of tints may require from a dozen to twenty printings, the Hoeschotype may be produced in five printings. The various stages of the color printing by which the finished print is built up are exceedingly interesting. The print we examined was a photograph of a girl. Plate No. 1 showed only the yellow tint graduating from the deep points of color in the hat to the light tints in the hair. The outline of the features were only just discernible, while the cheeks were left white. In the next printing the color was red. Here, where necessary, the red mingled with the yellow, producing orange. No. 3 was blue, and the greens and purples made their appearance in their proper places. No. 4 was a neutral tint of gray, which toned down the crudeness of the three primaries. Finally came the brown, which gave a mellowness and warmth to the shadows, and completed the picture. For the result we have nothing but praise; and if examples like the ones we saw at Messrs. Gladwell's can be produced rapidly and at a small cost, chromolithography will be almost superseded. It is evident that some artistic skill in manipulating the gelatine plate is absolutely necessary, for herein lies the power of being able to produce graduated tints at one working; but whether the gelatine is worked upon, before or after being bichromatized we are unable to say. So far as the artistic element is concerned we understand that Herr Hoesch is certain that any South Kensington student of average skill could, with three months' practice, acquire proficiency. If this be so, there is no insuperable difficulty for the artist. We believe that no attempt has been made in connection with enlargements of portraits from life, but we saw several Hoeschotypes of vases from the objects themselves, which left nothing to be desired. Of course it is not necessary to use five tints in every case, and in the reproductions of the vases three only were employed. To insure absolute accuracy in the matching of tints, the inventor has prepared a scale in which every combination of the five colors in certain proportions is shown. Herr Hoesch divided his five colors into fifths, and having thus twenty-five portions to ring the changes upon, he gets 1,600 tints, each of which has a number attached to it which shows on reference to a table that it is composed of so many fifths of one color, and so many fifths of another, as the case may be. The equality of the prints may therefore be depended upon. So far as we could see from the results shown by Messrs. Gladwell, there is hope that the Hoeschotype may take its place before long as one of the recognized art processes of the day.—*Photo. News.*

ALBUMEN IN COWS' MILK.

Dr. Schmidt, Mülheim, has been investigating the nitrogenous bodies in cows' milk, about which so much diversity of opinion has hitherto prevailed. He says that three albuminoid substances are regularly present in the milk, viz: caseine, albumen, and pepton. The average of seven analyses gave 2.43 per cent of caseine, 0.38 per cent of albumen, and 0.13 per cent of pepton. Under certain circumstances the amount of albumen may increase until it equals that of the albumen. The pepton is formed from the caseine by a fermentative process; this ferment is destroyed by a boiling temperature, but its activity is not destroyed by salicylic or carbolic acid, so that in this respect it resembles the ferment that digests the albuminoids. Since milk, on long standing, may lose 10 per cent or more of its caseine by its conversion into pepton, it should be made use of as fresh as possible when employed for making cheese.

THE GREAT COMET.

The name of our new celestial visitor must, it appears, now be changed from Cruls' comet to Gould's comet. Late advices received at Harvard College Observatory from Dr. B. A. Gould, at Cordova, S. A., show that the honor of the discovery of the great comet belongs to him. It was first seen at his observatory more than a day previous to its discovery by Finlay at the Cape of Good Hope, and five days before it was seen by Dr. Cruls at Rio. Late letters from the Cape to a prominent English astronomer show that the comet was observed there upon the day of its perihelion passage clear up to the edge of the sun, where it suddenly disappeared. This observation has no parallel in the history of astronomy, and is evidence of the extraordinary brilliancy of the comet. Mr. Chandler, of the Harvard Observatory, has just computed a new orbit, which is of much greater accuracy than any heretofore obtained, and gives unmistakable evidence of periodicity. By means of this a comparison of the observation of Finlay with the position which the present orbit gives for that date has been made, and the variation between the observed and the computed place is less than the diameter of the nucleus of the comet. From this close agreement it is evident that no sensible perturbation attends the very close approach to the sun.

We learn, however, that Professor William R. Brooks, of the Red House Observatory, Phelps, N. Y., on the morning of October 21, while sweeping the heavens in the region of the great comet with his new nine-inch reflecting telescope, discovered a new fragmentary comet, eight degrees east of the great comet. It was a cometary mass, nearly two degrees in length, slightly condensed in the part toward the sun, and resembled in form the celebrated fragment detached from Biela's comet several years ago.

On the following morning the professor was enabled to verify his discovery by a second observation, when it appeared somewhat smaller and fainter, yet unmistakable as to its character.

The comet thus appears to have been in a terrible state of commotion since it left the immediate neighborhood of the sun, and Prof. Brooks believes that this new fragmentary comet was formed of an envelope thrown off during its disturbed condition. We are sorry to say, however, that the great spyglass at Washington, when turned on to the comet a few days later, did not confirm the observation of Prof. Brooks.

Commander Sampson, of the Naval Observatory, observed the comet on the morning of October 25, for the first time, through the great 26-inch equatorial telescope. It has not before had sufficient altitude to be visible to this instrument. With a low-power eye piece an excellent view was had of the nucleus, which presented an appearance quite different from that seen in the smaller instrument, and showing with considerable distinctness all the appearance which has led to the opinion that the comet was breaking up. In the large instrument the nucleus has a well-defined center, which is quite circular and of considerable apparent diameter. The elongated appearance of the nucleus is due to two masses of nebulous matter, one of which is between the nucleus proper and the sun, and the other on the side toward the tail. Both these masses are somewhat detached from the nucleus — the one in the direction of the tail being the brighter, but neither presenting the condensed sun-like appearance of the nucleus. These luminous portions of the coma are probably the appearances that have been observed for separate portions of the comet, and led to the belief that the comet had "split." The spectroscope this morning showed that the character of the light of the comet had not changed during the past week. It indicates that incandescent carbon vapor is the principal source of light. A search for the small comet reported last Saturday east of the great comet was not successful.

THE COLOR OF WATER.

Experiments made by J. Aiken confirm the usual notion that pure water has a blue tint; but he finds that the theory of selective reflection is insufficient to account for all the variations as to tint met with in the case of natural accumulations of water. Whitish particles are suspended in the water of the Mediterranean, and the tint varies from deep blue to chalky blue-green, according to the proportion in which these particles may be present.

Health and Home.

FOODS FOR INFANTS AND INVALIDS.

It may be questioned whether there is any subject which comes more closely home to people of all classes than the character of the food supplies specially provided for infants and invalids. The increasing demand for this class of preparations (due partly to an actual need, but chiefly, we suspect to the skillful advertising of manufacturers and the liberal margin of profit they offer to the retail trade), has led to a great number and variety of such competitors for public favor. Put up in ornamental boxes, they appear on the counters of every grocer and in the show cases of every apothecary shop; and not unfrequently their actual value is in inverse ratio to the pretentiousness of the package and the price.

As a rule, purchasers are obliged to take the virtue of such articles upon trust, few having the means or the knowledge requisite for an analysis, microscopic or chemical, of the preparations which they are advised to try, perhaps by the family physician, and yet a mistake in this connection may be fatal.

For all young infants, and for adults in many cases of sickness, starch food is injurious; sometimes in being a source of intestinal irritation; sometimes, as in the case of very young children, in furnishing a semblance of aliment without the reality, such children being as unable to digest and assimilate starch as sand. Hence the usual claim with respect to prepared foods of the cereal class is that they are free from or contain very little starch, while they are rich in gluten and other food elements capable of nourishing the sick and the young. To discover how far these claims are well founded, Dr. Ephraim Cutter, of Harvard College and the University of Pennsylvania, has lately made microscopic examinations of something like forty cereal foods, developing facts of the highest importance to physicians and their patients as well as to parents having young children.

SULPHOCYANIDE OF BARIUM.

The adulteration of this substance is carried to such a degree that in some French specimens only 80 per cent of the pure salt, $Ba(SCN)_2 \cdot 2H_2O$, was found, the impurities consisting largely of barium chloride.

Dr. J. Tscherniac gives the following simple test. The sulphocyanide of barium is completely soluble in absolute alcohol, while all the barium salts that can be profitably employed for adulteration are insoluble in it, or very slightly so. Hence it is only necessary to shake a sample of the salt with two or three times its weight of alcohol, and then wash, dry, and weigh the insoluble residue, to determine the quantity of impurities.

EVAPORATION OF LIQUIDS.—WAHL'S IMPROVED VACUUM PAN.

Evaporation and concentration of liquids is an operation of special importance in almost every one of the chemical industries. Solutions of sugar, glucose, glue, extracts of dye-woods, tanbark, meat, and other substances, wort, milk, and a great many other liquids have to be concentrated by evaporation, to either advance them in the course of manufacture or to bring them into a marketable condition. For all these purposes vacuum pans are now generally used, as they allow the evaporation to be carried on at a comparatively low temperature, and thus largely diminish the chance for liquids becoming colored or undergoing changes in their chemical composition. But although these dangers are diminished, they are by no means entirely obviated, for even in vacuum pans of the best construction, solutions are colored and decomposed to a more or less extent. Cane sugar is converted into molasses, glue into glycine, while all other substances are colored in a more or less degree, owing to the long time during which the liquids are exposed to the temperature in the vacuum pan.

Mr. C. Wahl, of the firm of Wahl Bros., of Chicago, who in many ways has advanced the manufacture of glue, fat, and other animal products, conceived the idea that a pan might be constructed in which the liquid would have to remain the shortest possible time while being evaporated. The construction of the vacuum pan, illustrated in the accompanying cuts, Figs. 1 and 2, is the result of his endeavors, which, as it will be seen, were crowned with perfect success.

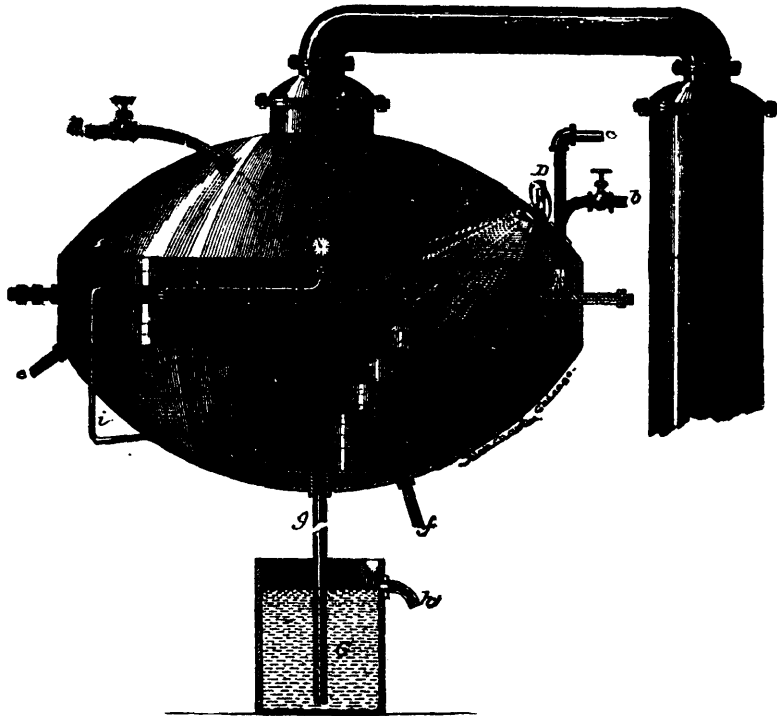

FIG. 1.

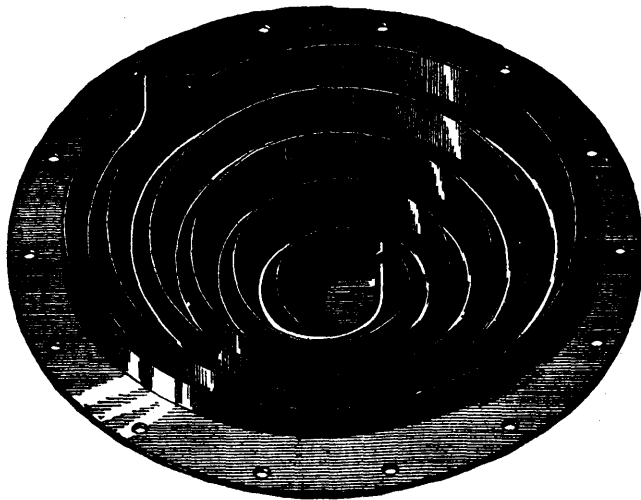
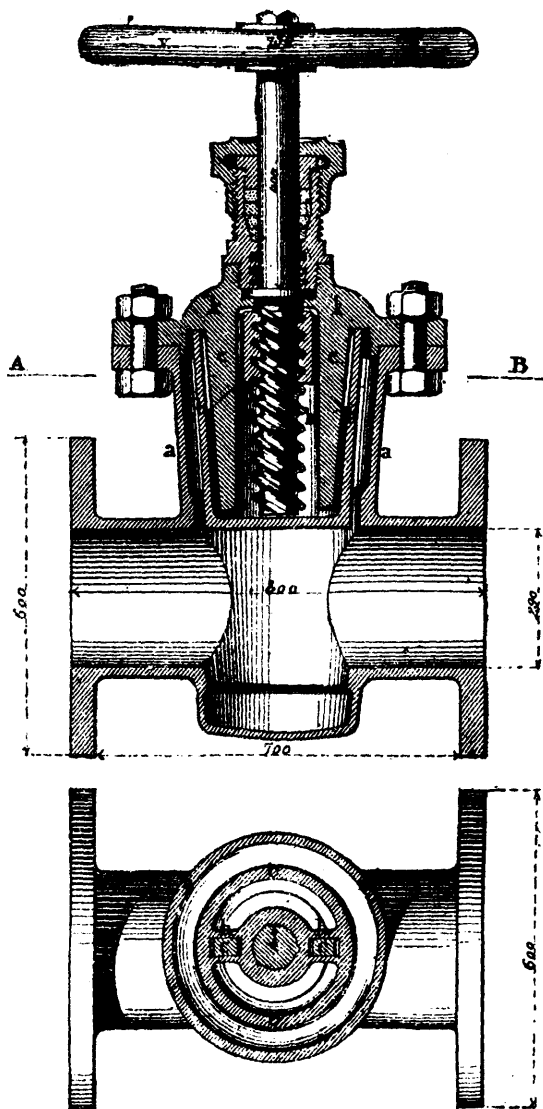

FIG. 2.—WAHL'S IMPROVED VACUUM PAN.

Fig. 1 shows a view of the pan and a part of the inside arrangements; the pan is provided with the usual attachments, eyeglasses D, a condenser F, vacuum gauge, thermometer, etc., but the liquid to be evaporated, instead of being filled into the pan in one bulk, passes gradually through the spiral shaped canal or gutter, A, which is shown separately in Fig. 2. The space formed between this continuous channel and the bottom of the pan is used as a steam jacket, the heating capacity of which is increased by a coil of steam pipe, B, running along on the bottom of the channel, *d* and *c* represents the inlets, and *e*

and *f* the outlets for the steam. The liquid to be concentrated runs in at *b*, and after being concentrated issues at *g*, and runs into a vessel, G, located about thirty feet below the vacuum pan. Where the localities do not admit of this latter arrangement, the concentrated liquid must be pumped out, in which case vessels to be used alternately will be found convenient for the reception of the concentrated mass. It will be seen that the operation of this pan is continuous, and that its working can be regulated with the precision of clockwork by the admission of liquid through the faucet *b*. While in the old style



CHATEL'S DIRECT ACTING STEAM COCK.

CHATEL'S DIRECT ACTING STEAM COCK.

The bronze cock shown in the annexed figure consists of a shell *a*, closed at the top by a hemispherical cap, *K*, with which is cast in a piece the two guides, *c c*, which serve to maintain in a vertical position the conical key, *b*. When the hand wheel, *V*, of the screw, *F*, is revolved, the nut, *d*, which is connected with the key, *b*, by means of the projections, *h*, moves upward or downward and carries along with it the key.

It will be seen from this that the arrangement of this cock allows of the integral section of the pipe being preserved—a first class advantage that is not met with in ordinary cocks; for the section of these, being usually different from that of the conduits, diminishes the pressure of the steam.

As the key of the cock under consideration does not revolve in the shell, it follows that there is no gripping. As for the closing of the cock, that is perfect because of the great surface of contact of the key and its seat.—*Scientific American*.

Pans large batches containing up to fifty barrels are treated at the same time, being exposed to the high temperature for hours and more, in Wahl's pan every drop, so to speak, is treated by itself, and leaves the pan after having attained the desired concentration, which is accomplished in a few minutes, owing to the effective application of heat, which has to penetrate a low column of liquid of one-half to two inches height at the utmost.

The high column of liquid in the old style pans also causes violent ebullition and overboiling, which cannot happen with this improved apparatus. At the glue works of Messrs. Wahl Bros., of Chicago, these pans have been in successful operation for some time past, and parties desiring information will receive prompt answer by addressing them. The use of this pan is not confined to the evaporation of liquids, but the principle involved may also be applied in the cooling of liquids, such as wort, etc. The drying of lard oils and other substances can also be effected in this apparatus in the shortest possible time and without discoloration and decomposition.

Architecture and House Decoration.

SUGGESTIONS TO THE STUDENTS OF ARCHITECTURE.

BY C. FRANCIS OSBORNE, PROFESSOR OF ARCHITECTURE IN CORNELL UNIVERSITY.

The frequency of the communications in the columns of the *Builder and Wood Worker* for advice in regard to the proper course to be pursued by young men who contemplate fitting themselves for the practice of architecture, has led me to think that a few notes on the subject of a general course of study leading to the desired end might not be unacceptable. The writer has had the privilege of advising in not a few such cases, and has reason to believe his advice has borne good fruit.

It is the result of his experience that the chief difficulty in all such cases arises from a misunderstanding of the true nature of the profession which it is intended to adopt; and so it would be best, perhaps to have a clear understanding of what it is an architect's duty to know, before proceeding to discuss the best way of acquiring such knowledge.

Now an architect is evidently one who is qualified to practice architecture, or, as it is better expressed, *the art of good building*; and as to what the latter is, I think the definition of Sir Henry Wotton is the most concise and best suited to our present inquiry. "Well, building," said he, "has three conditions: fitness, firmness, and fairness"—the three F's, it might be said, of the profession, each an equally important factor of a complete whole. That is to say, in order to build well (and no architect could care to do otherwise), we must build so that our work shall be:

- (1) Convenient, *i. e.*, fitted to its use;
- (2) Firm and stable; and,
- (3) Fair, *i. e.*, pleasing to the mind.

Such then is architecture, and such must be the scope of the architect's knowledge, in order that he may be fully qualified to practice his profession.

Now that he may build *fitly*, he must have learned, from study and experience the habits of men in the various conditions of human life; and that he may be prepared to properly design such buildings as are usually allotted him, he must have observed and studied his fellow beings in their home life; in their education; in their various occupations; in their public workshop; in sickness and in health; and in all the other accidents of their existence. He must be able to sympathize with all conditions of them both as individuals and as communities, and so be able to provide them with buildings wherein they may pursue their various vocations; which buildings shall, by reason of his knowledge so acquired, be thoroughly well fitted to their various uses. In order that he may build *firmly*, he must know, as far as may be, the qualities and characteristics of the various materials which he will use in his work. He must know their relative fitness for different purposes, and what are the best means of using them under the varying conditions which arise incident to his practice. And he must be able to calculate the effect of such new arrangements of his materials as he may find it necessary to adopt in special cases, together with the best methods of combining these materials in all the usual constructions: such knowledge not only enabling him to meet properly the requirements of any given case, but serving as well to give him that confidence in the result which all practitioners should have. And in order that he may build *fairly*, that he may please the eyes of his fellow men—and so in some measure compensate them for that portion of the earth and sky which his buildings shall have obliterated from their sight—he must learn the laws of design, which are founded, as all laws should be, on principles of truth and justice. He must study the designs of other men and other ages, that he may learn from them how best to carry out those laws in a fitting manner, and how best to avoid those many departures from them with which the course of the history of design is so lamentably disfigured. And finally, he must possess the knowledge and skill so to put down upon paper the results of his studies in all these matters, that he may enable his workmen to carry out his designs according to his true intention. A long and seemingly formidable course of study, but one which can and must be mastered ere any man may, in justice, write himself "architect"—*chief builder*.

Now as to the best way of acquiring this knowledge. It is always well, of course, to advise in such matters in accordance with the needs of each individual case, since it is difficult to lay down any general plan equally well suited to all students. But to the end that the suggestions here made shall be applicable to the largest possible number of cases, such a course of study will be given as is to be recommended to a student just setting out to acquire his profession; leaving each inquirer to determine for himself what part of such a course he is qualified in.

In order that he may learn the first important step—the proper methods of handling his drawing instruments and of acquiring correct habits of draughting—I should advise the student to begin with a course of problems in practical geometry, not only for the reason that it is in itself an excellent introduction to linear drawing, but because it will enable him to acquire, simultaneously with the practice it gives him, a knowledge of certain matters which he will find very necessary at a point further on in his course. These problems should include exercises in all the divisions of plain geometry, *viz.*, lines, angles, polygons, the conic sections, and the transcendental loci. There are but a few good text books on the subject, but as all the problems are worked out in them, little or no preliminary knowledge of mathematics is required at this point of the course. The architectural student will probably find Tarn's *Practical Geometry* most useful in this connection, as it is prepared with a view to his special needs. Next, he should procure some good examples of linear drawing, such as tile patterns, outline elevations of buildings, etc., and make careful and accurate copies of them; remembering always that there are three things he must strive to attain in his work—(1) Precision; (2) Neatness; (3) Celerity, and in the order named. These being attained, he should next proceed to the laying on of tints, and washes of color and ink; beginning with tile and other patterns in ink. He is now prepared to make creditable copies of architectural drawings, a process involving all the knowledge he has previously acquired, both as regards form and color. He should copy here over as wide a range of subjects as possible, including working plans and elevations, detail drawings, and sketches of detail in freehand. And let me say here that the practice of freehand sketching, should be begun as soon as possible, and continued to the end; as there is no one requirement of so much value to the student, both as regards the method of training involved and the value of the accomplishment itself. The subjects of his sketches should range from copies of freehand sketches of plans and solids, to drawings by the student from the cast, or finally to sketching from nature as well as from the building. The vast fund of motives to be found by a careful sketcher of natural forms, will give him a valuable collection to be drawn from in his future work. The student is now ready to begin the study of materials, which should be carried on simultaneously with that of the mechanics of buildings; the former dealing with the characteristics and capabilities of all the building materials, and the latter with the best methods of using them in construction. This is of the utmost importance, as need scarcely be pointed out; since by such knowledge we are enabled to use the right things in the right places, and to be confident that we have done so. For materials and methods of construction I do not know of any one work which is so good as the *Notes on Building Construction*, published by the Rivingtons, London. The student should be cautioned, however, that while it contains an excellent exposition of the nature of materials and the methods of construction, some of the examples of the latter, as given in its pages, are different from methods used in similar circumstances in this country. This work, however, supplemented by a careful study of Hatfield's *Transverse Strains* (this, an invaluable treatise for the student), and finally a constant course of observations and sketches of such examples of sound construction as the student may have access to, will equip him with all the preliminary knowledge of those things he can well acquire.

Design might be defined as the art of shaping and disposing the materials used in building in the most proper manner. The student, therefore, having arrived at a due understanding of the nature of such materials and of the laws which govern their combinations, is fully prepared to enter upon the last stage of his studies—the mastering of the principles and practice of design. This is in order that he may round out his work with that last great quality of "well building"—*fairness*. I should advise him to begin with the study of planning, since the plan is the germ of all building. He should make himself

familiar with the laws which govern it (for it is very nearly an exact science), and study how to apply them so as to fitly meet the requirements of each special case. The book that will most help him here is *The Gentleman's House*, or, *Stevenson's House Architecture*, Vol. II. The former is a more elaborate and scientific work than the latter, but inferior to it in some other respects. Then let the student carefully read the following works, in the order named: *Ruskin's Stones of Venice*, and *The Seven Lamps of Architecture*; and *Garbett's Principles of Design*; this last not at all to be compared in value to the former, but containing nevertheless some thoughtful suggestions. Then, finally, let him study the history of architectural design from the earliest historic times to the present day; being careful to note how the fundamental principles of the best builders of all ages have been the same, and how the violation of them has surely and instantly been followed by a loss of purity and beauty in the design, from the pseudo Greek of the first centuries to the last new wrinkle in "Queen Anne," and from the time that the mastery of materials and their applications is acquired, let the student make himself familiar with the current of the professional thought of his day, as reflected in the pages of the professional journals, both in this country and abroad—lest, having acquired a sufficiency of book knowledge only, he emerge from his seclusion to find himself confronted with the conditions of professional life, of whose existence he has been as ignorant as he is unable to overcome the difficulties they present. Then, and at last, he might feel able to enter the practical duties of his profession, with the consciousness of possessing a sound knowledge of its principles which only practice and experience can improve.

It only remains to be said that this course has been sketched but in the barest outline. That many things of great importance have been no more than alluded to, while others equally important have been taken for granted. And finally, if I were asked whether it be possible for any student to master such a course unaided, and alone, I should say frankly "no," for while there are some portions of it that could be acquired unaided, in spare hours, taken it may be from other pursuits, a great deal of it can only be learned in an architect's office, or in one of our architectural schools, and some of it only in the latter. And my advice to all architectural students of limited means would be, to take at least one year's course of study in such a school. There are three or four now in operation in this country doing good work, and aiming to provide that higher professional education which the condition of things with increasing earnestness, year by year, and, as I have said, there is experience of the highest value to be had in them, which cannot be acquired elsewhere. The libraries, museums, photographic collections, etc., of such schools present advantages to the student that he could command in no other way.

One word more. It has been well said that on any given subject there is always some one book which contains it all. Though it would be too much to expect this to be literally true of such a comprehensive subject as architecture, yet *Gwilt's Encyclopedia of Architecture* comes near to meeting the requirements of the case; and I would advise the student who has to count the cost of his education closely, to buy this one book in preference to three or four others. It is by no means complete, and it is undoubtedly true that any one of the subjects contained in it is better treated elsewhere, but the point I wish to make is, that there is no other way of possessing so much professional information for so little money. The last edition, edited by Papworth, is the best.—*Builder and Wood-Worker*.

FASHION IN WOODS.

At the opening of the present century, the standard of taste, with regard to colored and ornamental woods, was very low. High-colored, highly-figured, and gaudy woods, says the *Building News*, were in requisition in the field of furniture, the inlays and mouldings being largely of brass, this latter being a distinct characteristic of what is called the "Furniture of the First Empire." Wainscoting had vanished from the walls of the apartments, and the joiner or house-fitter had surrendered this great and ancient branch of his craft, one which had been so intimately associated with wood, to the workers in plasters. The fittings of the houses and other edifices were plain and commonplace, and largely made up in effect by painting in imitation of wood—a work of sham or deception

from which we are not altogether free. This was an age of sham construction; we had sham woods and marbles, the creations, so to speak, of the house painters; and sham stonework in the form of stucco, the handiwork of the plasterers. This taste for sham wood largely extended to furniture, especially to that of a bedroom character—a sham we are but slowly emancipating ourselves from. The early part of this century saw two great inventions brought into practical use—first, the art of French-polishing wood, and, second, that of cutting veneers by machinery. On the one hand we had a beauty added to colored and ornamental woods, and, on the other, a cheapening of the same in the form of veneer. The art of veneering, or plating common wood with costly woods, was carried to a great, and, we may say, a foolish extent. Although not sham work in the sense of painting or imitating other woods, it was sham work so far as the solidity of the furniture was concerned. Furniture characterized as of a given class of wood was that only to the eye, the true wood forming only a skin or face for a ground or framework of common material.

The standard of taste being low, a craving was caused for highly-figured and colored woods, at the head of which, in a double sense, stood curled mahogany. This wood was tolerated in every room of the house, accompanied with its gaudy flaming curls, the latter being found on the front of the drawers and wardrobes, wound round the moldings, posts and cornices of the bedsteads, on the pianoforte cases and table tops of the drawing rooms, and the hideous Trafalgar chairs and sideboards of the dining room.

Mahogany at this period had a firm hold of the cabinet makers, and although its color was, and is, decidedly objectionable in the bedrooms, it appeared to coalesce with the heavy draperies and funeral character of the rooms of that tasteless period.

Toward the close of the first half of the present century, certain well marked changes had occurred in the use of colored and ornamental woods. Mahogany had largely receded from the drawing rooms in favor of rose wood and zebra wood; the latter, as the name implies, being a gaudy, vulgar wood, and one wholly unsuited for enriching with moldings or carvings—a remark which, in a large degree, applies to its companion, rosewood. Mahogany was slow to retire from the dining room, its competitor in this case being oak, with which the old taste of color and figure was associated—a taste that was satisfied by the introduction or adoption of brown, pollard, or stained oaks.

In the broader field of bedroom furniture mahogany found rivals in the Canadian bird's eye maple and birch, the value of which was gauged by the standard of figure.

During the third quarter of the century the tastes and fashions of the second quarter largely obtained; the changes being marked on the one hand by the introduction of new woods, on the revival of other woods, such as walnut, which has retired, in favor of the taste for high colored woods. The drawing rooms, in adopting walnut, made an easy change or mutation from rosewood, in which field it has gained absolute mastery, its progress being marked by the abandonment of the old vulgar taste or standard of figure.

The dining rooms have gone over more fully to the use of oak, which has again been marked by a departure from the standard of figure, plain and uniform colored woods being quite as fashionable as the brown or pollard varieties.

The furniture woods of the bedroom have received additions in the form of Austrian and Canadian ash, and in Quebec and pitch pine, the latter being specially associated with figure.

The fashion in woods has during the last ten years been influenced by a new agent, or, at least, an agent new to this century—viz., "art." We are in the very throes of a great revival of art, and we are doing our best to bridge over the gulf or interregnum caused by the French Revolution, which, like a blight, has fallen upon the past ninety years, and has dealt a blow almost deathlike, to art in every channel. We are following the age of good Queen Anne followed that of the levellor, Cromwell, and in every respect we are repeating history.

So far as furniture is concerned, a great blow has been struck at highly figured woods, which are held to be alien to our canons of art. Rosewood and zebra woods are discarded, and the fabulous prices paid for figured and curled specimens of mahogany and walnut are details of history. Color has not been so markedly affected; but it has been much subdued,

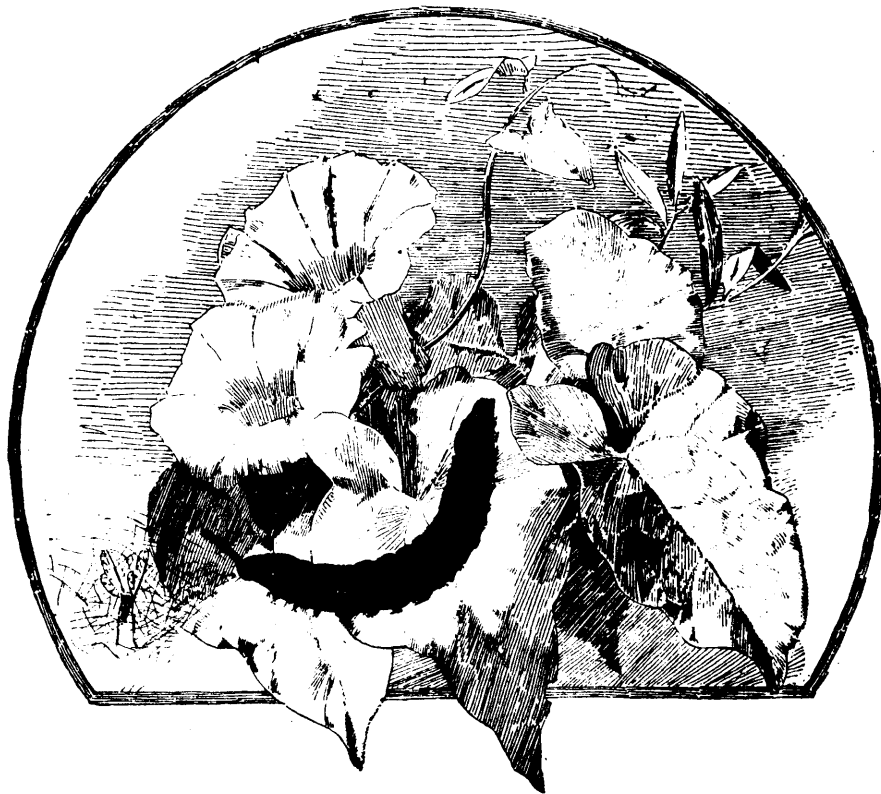

THE PERIPATUS.

and brought within well defined lines. It has been found that ornament, as in the case of carving, is misplaced on figured grounds, and the artist in wood revolts at this class of wood in the same degree as a sculptor revolts at veined marble. It has been a question whether ornament shall be natural in the wood, as in the form of figure; or whether it shall be applied to a self colored wood, in the form of moldings, carvings, and chaste outlines. It has been decided that the ornament natural to the wood is not sufficient to meet the cravings or standard of art as prevailing to day, and that satisfaction can only be found in adopting figureless woods, and enriching the same with carvings and other adjuncts of ornament.

In the drawing room this change has been wrought, whilst walnut wood has been in fashion. It is but as yesterday that highly figured walnut wood was sought after, and the choicest specimens were brought from France, Italy and the shores of the Black Sea, to find a ready market in this country. As a groundwork, the cheap and figureless walnut wood of America was introduced, with no thought of its ever becoming a rival of this figured variety. Such is the change wrought in this detail that, to day, the figureless black walnut wood of America is the fashionable wood, to be obtained only at a high price, whilst the European figured variety is largely in stock, and unsalable in our great London and Liverpool wood markets.

Woods plain in figure and unobtrusive in color are now the order of the day; the result is not a sacrifice of ornament, for this desirable feature is obtained at the hands of the artist in such adjuncts as carvings, inlays, painted and silvered panels, and ornament in low relief. Mahogany may be said to still retain some hold in the field of artistic furniture; but it is secondary to the position of American walnut, the application of which is manifold. It may truly be termed a figureless

wood; but where this grain is objected to, a 'onized wood', which may be considered its offshoot, is introduced, and, between the two, they practically monopolize the fields of high class or art furniture.

Walnut wood is found in the drawing room, the dining room, and the bed rooms, its sombre hue in the latter case being met by its sparing use, and the light character of its framing; large plain surfaces, the object of which in former times was to show the high figure of the wood of construction being avoided. As a fashionable wood it has overshadowed all other woods: before it mahogany, oak, birch, ash, and maple have retired. The revival of art, so far as furniture is concerned, has had the effect of destroying the taste for highly colored and figured woods, and of lightening the same by removing the great masses of wood which intruded themselves in such a clumsy manner upon the eye. — *Am. Cabinet Maker.*

Natural History.

THE PERIPATUS AND ITS REMARKABLE METHOD OF CAPTURING PREY.

BY C. F. HOLDER.

Among the many interesting creatures that have been unearthed by scientific investigation during the past few years, the peripatus deservedly stands foremost in the rank, not alone for its peculiar individuality, but for certain habits shown when obtaining food and defending itself from attack. According to late classification it forms the single insect of the sub class Malacopoda, and is only represented by a single genus—Peripatus. It is considered an extremely ancient form, from its



THE DOVE FLOWER.

wide and peculiar distribution, being found at Cape of Good Hope, St. Thomas, Australia, New Zealand, Chili, and Isthmus of Panama, and thought the nearest extant representative of the ancestors of our air-breathing anthropoda, spiders, etc.

In appearance the *Peripatus capensis* is exceedingly disagreeable, resembling a large black caterpillar, three inches or more in length. From the head protrude a pair of curious jointed horns like antennæ that incline forward, seemingly used as feelers, though the head bears a small pair of simple eyes. Beneath is the mouth with its singularly turned lips and double pair of horny jaws, well adapted for crunching the larger game it affects. The seventeen pairs of feet are short, fleshy, and provided with two short claws adapted for clinging upon rocks or trees. The body is cylindrical and soft, the integument not chitinized, and head not separate from the body, its great

difference from other anthropods being in its "two widely separately minutely ganglionated nervous cords sent backward from the brain; also in the minute numerous tracheal twigs arising from the many minute oval openings situated irregularly along the median line of the ventral surface of the body." It calls to mind features of *Lingualulina* and *Tardigrada* by its curious soft clawed feet, and, according to Packard, is not a worm, but an intermediate between them and the sucking myriopods. Its method of breathing is peculiar in the extreme. Instead of the tracheal tubes opening to the exterior by small stigmata arranged along the body in regular order, as in other animals that have tracheæ, their tracheæ are scattered here and there over the entire body. It appears, says Moseley, that we have existing in *Peripatus* almost the earliest stage in the evolution of tracheæ, and that these air tubes were de-

veloped in the first tracheate animal out of skin glands scattered all over the body. In higher tracheate animals the tracheal openings have become restricted to certain definite positions by the action of natural selection.

The sexes are distinct, and the males much smaller and rarer than the females. Out of fifty specimens found only two were males. The females are viviparous, and according to the above mentioned distinguished author, a standard-bearer of the lamented Darwin, the process of development of the young shows that the horny jaws of the animal are the slightly modified claws of a pair of limbs turned inward over the mouth as development proceeds; in fact, "foot jaws," as in other arthropods.

To Mosley is due all the present knowledge concerning this curious insect, and previous to his elaborate examinations at the Cape of Good Hope nothing was known as to its methods of breathing air by means of tracheæ, scientists believing it to be an annelid.

In the accompanying cut the great peculiarity of the animal is shown. Being slow, cumbersome, and utterly unable to pursue game, it seems to have been provided by nature with ample compensation. We see it lying upon the ground almost invisible, so similar is it in color to its surroundings; a fly or some larger insect approaches; the two horns dilate, move to and fro, as if in excitement, and the approaching fly, when within several inches, suddenly stops, as if paralyzed, and unable to move, but remains suspended in the air. We draw nearer and see the cause of this phenomenon. At the approach of the victim the *Peripatus* has ejected from its mouth curious thread-like jets of some glutinous irritating fluid that forms instantaneously, as if by magic, a complete network of gleaming, glistening web, that resembles the maze of the spider with its quivering drops of dew. Myriads of these glistening darts or threads encompass the victim, holding it in a close embrace until the unwieldy *Peripatus* approaches, breaking through the sheeny prison and releasing the victim to a worse fate.

This remarkable web is found to proceed from large glands that secrete a clear viscid fluid that seems to crystallize when ejected from the papilla, one of which is found at each side of the mouth. If the *Peripatus* is attacked suddenly the web appears in front of it instantly, the jet forming a perfect protection from many enemies as it is almost tenacious as bird-lime. It is not an irritant when tasted, but when taken from the glands and placed upon a glass slide, forms a trap for the largest insects, holding them securely.

The food of the *Peripatus* is, however, to a great extent, vegetable, and in the stomachs of nearly all the specimens examined by Professor Mosley at Good Hope, vegetable matter was found. In their habits they are similar to the common centipedes, living under logs, stones, and dead wood. They are nocturnal insects, moving about in a slow, hesitating manner in the day-time. When at rest the body is perhaps two inches long, but in motion they stretch out in a surprising manner to nearly twice that length. Most of the specimens found by Professor Mosley were in old willows that were highly luminous, and in the weird light the insects were seen coiled up ready for transportation to the collecting case. Professor Mosley thus describes the search for this *rara insecta*:

"My colleague, the late Von Willemoes Suhm, and I both searched hard for *Peripatus*. He was unsuccessful, but I was lucky enough to find a fine specimen first under an old cart wheel at Wynberg. Immediately that I opened this one I saw its tracheæ and the fully-formed young within it. Had my colleague lighted on the specimen he would no doubt have made the discovery instead."

In New Zealand, the species known as *P. Nova Zealande* is found among the dead wood near Wellington. Here also the females predominate. It much resembles the *Capensis*, having, however, thirty feet instead of thirty-four.

Equally remarkable as a web constructor are the larvæ of a lepidopterous insect, the *Hyphantidium sericarium*, found in Australia. Myriads of the creatures join forces and produce a silken web, in some cases measuring nearly three hundred square feet. Mrs. Thos. Wiseman, of Australia, has successfully raised numbers of them and sent specimens to Europe. Mr. Helenus Scott of the Wollombi, thus refers to her work in a communication sent to an English naturalist with some specimens:

"Mrs. Wiseman had placed a quantity of shelled maize in a veranda room, 8 feet 6 inches long, 6 feet wide, and 9 feet 3 inches high, the stone walls being plastered. At a subsequent period, this room being required for a bedroom, the walls were

found to be entirely and uniformly covered by a beautiful white-colored web, fastened at the ceiling, floor and corners by a stouter and coarser fabric, and occasionally to portions of the wall itself; so that in this instance an unbroken sheet of cloth, containing some 72 square feet, might with care have been obtained; while the web measured at least some 252 square feet. The specimens of this cloth sent to me, rudely torn from the walls, were of the size of a large handkerchief. The remaining portions of the original construction had been ruthlessly destroyed by the servants. The larva, when full-grown, is about five-twelfths of an inch in length, with the head and first annulation depressed somewhat horny, and of a blackish-brown. It possesses sixteen feet.

"It is of a pale yellowish-white color, with whorls of six small black spots on each annulation, each emitting, a tiny hair. The caudal segment is spotted with brown.

"In confinement these caterpillars were found to be active, with a dislike to the light; so that, when exposed, they immediately commenced spinning their web, connecting together several grains of the maize, upon which they subsisted. They likewise lined the top and sides of the box with their silken tissue.

"At the latter end of August they assumed the pupa state, each larva forming a separate cocoon for itself among the maize, consisting of a flimsy web somewhat tightly enveloping the chrysalis, which was of a light yellowish-brown, with the wing cases largely developed and one-third of an inch in length.

"The perfect insect took wing in October, and is three-fourths of an inch in expanse, and active in its movements. The superior wings were elongated, the costal margin arched, and apices rounded. General color grayish-brown, of a silvery hue, with stigmata and strigæ of a darker color. Inferior wings of a light semi-transparent silvery hue, with a deep marginal fringe. Thorax similar in color to the anterior wings, and not crested. Abdomen, yellowish; the whole of the under side light silvery-gray. The wings are slightly convoluted in repose."—*Scientific American*.

THE DOVE FLOWER.

The dove flower, or *Peristeria alata* has its home in Central America. The leaves of the flower are white and spotted, and give the flower the appearance of a white bird with extended wings. The inhabitants of Central America adore this flower, believing that it represents the Holy Ghost on account of the resemblance to a white dove, the symbol of the Holy Ghost. For that reason the flower is also known in that country as "Flora el Spirito Santo." The flower represented in our cut was in bloom in the garden of Mr. L. M. Stone, 482 Franklin Avenue, Brooklyn, a short time ago.

FORESTS AND CLIMATE.

A paper has been prepared by Dr. Schomburgk, the Director of the Botanical Gardens at Adelaide, on the influence of forests on climate. The object of the author is to prove that the destruction of forests usually has the effect of reducing the rainfall, while, on the contrary, the planting of trees broadcast over a country is one of the best methods which can be adopted for ameliorating its climate and increasing the annual fall of rain. It cannot, indeed, be proved that the climate of South Australia is altering for the worse in this respect. In fact, a comparison of the meteorological records will show that the annual average rainfall for the colony during the past ten years has been 21.1 inches, as compared with 20.1 inches for the previous ten years. The fact is, that in the agricultural districts of the colony, and especially in those which were not originally timbered, the bringing of the land into cultivation has had the effect of slightly favoring the fall of rain. Plowed land attracts in moisture to a much greater degree than the unbroken soil. In considering the effect which the removal of forests *per se* has in altering the climate in South Australia, the only direct test that could be taken from the records issued by the Government Astronomer is the experience of the neighborhood of Adelaide. If the time is divided which has elapsed since 1839, the year in which observations were commenced, into two periods, there is found for the first an average rainfall of 22.8 inches, and for the second one of 21.7 inches. It will thus be seen that, on the whole, the rainfall at Adelaide is diminishing, though very slightly, and perhaps the diminution in the amount of timber may have something to do with the change. Dr. Schomburgk,

in searching for illustrations of the effect of trees on climate goes further afield, and brings forward some striking instances, in which it is evident that loss of forests means loss of rainfall, and *vice versa*. He recalls how the Russians, by burning down some of the Transcaucasian forests at the time of the struggle with the Circassians, converted the country from a fertile land into a desert, simply through the cutting off of the supply of rain. Similar instances of rain having deserted a country denuded of forests have occurred in the Mauritius, in Jamaica, the Azores, and, it may also be added, to a still more remarkable extent in several of the smaller West India islands. No sooner had the forests of these places been destroyed than the springs and rivulets ceased to flow, the rainfall became irregular, and even the deposition of dew was almost entirely checked. On the other hand, it is generally accepted as a fact that Mehemet Ali increased the fertility of Egypt enormously by planting trees. He alone planted some 20,000,000 on the Delta; his successors followed up the work, and it is a noteworthy circumstance that the rainfall rose from 6 inches to 40 inches. Planting has also, it would seem, produced remarkable effects in France and Algiers. Extensive regions have been planted with gums and other trees, which, for the most part, grew to about 30 feet or 40 feet in height, and it is noticed that the quantities of rain and dew which now fall on the adjacent land are double what they formerly were.—*Architect.*

THE PARASITE OF CONSUMPTION.

We find in the last issue of the *Popular Science Monthly* a very good summary of the experimental results of Dr. Koch, by which he claims to have succeeded in establishing the bacterial (parasitic) origin of tubercle. From this summary, which is made from a paper in the *Medical Press*, we make the following abstract:

In pursuing his investigations, Dr. Koch used material derived from both human and animal sources. He found on examining the tuberculous material deposited in various organs, the presence of minute organisms possessing all the characteristics of bacilli, from which he was led to infer that these forms of living organisms are invariably present in such tuberculous deposits. In a multitude of cases of milinary tuberculosis, bacilli in innumerable numbers were encountered in every affected situation, and he drew the conclusion that they inevitably accompany the development at least of the disease.

To demonstrate, however, that they are the cause of the affections, required an elaborate series of investigations, which he carried out by experiments upon animals. With this object, therefore, numbers of guinea pigs, rabbits and cats were operated upon, with the results, in every case, of verifying the conclusions which the experimenter had reached. By directly transferring the tuberculous matter from diseased animals to healthy ones, by inoculation, Dr. Koch succeeded in all cases in reproducing the disease. As, however, it was still possible that the contamination might be due to a virus contained in the transferred material rather than to the presence of microscopic organisms contained in it, "cultivation" experiments were introduced and conducted on a large scale. A pabulum was found, in which the bacilli grew and reproduced freely. By repeated sowings in new quantities of the nutritive matter, extending in some cases to six months, a generation of "purified" bacilli was obtained, which could not by any possibility be accused of communicating virus.

When these cultivated organisms were introduced into healthy animals, they never failed to reproduce themselves in incalculable numbers, and to set up all the symptoms of tuberculous infection. Thus, four guinea pigs were inoculated with bacilli of the fifth generations, produced in fifty-four days from tuberculous matter originally derived from a human subject. In each case the infected animal sickened and lost flesh, and was found, when killed, to have strongly pronounced tuberculosis. This took place no matter what part of the body was chosen for the introduction of the infective material. When some animals were injected with healthy blood serum at the same time that others were inoculated with bacilli, the latter sickened and became tuberculous, while the former were not affected.

In another series of experiments, the sputum of consumptive patients, even after having been thoroughly dried, was found to be competent to transmit the infection. Dr. Koch is still engaged on this important investigation, to determine the conditions necessary for the development of *Bacilli tuberculosis*, and other points of interest in connection with the subject.

A CHEAP RAILWAY.

There is now at work an interesting miniature railway—five miles in length—which unites the village of Westerde in East Frisia with the station of Ocholt on the Oldenburg and Seer line. It is solely due to the enterprise of the thinly-scattered population of the district, and carries their cattle and other produce to market, bringing them back their few requirements. The soil is marshy, so that a good deal of drainage work had to be done, and it was necessary to carry the line above the level of the frequent floods. In spite of this, the cost of construction was only £2,103 7s. 6d. per mile; and the cost of working (including wages, fuel, and every expense) amounts to the magnificent total of £1 7s. 6d. per diem. The buildings consist of a shed at each end of the line; the terminus is the courtyard of the principal inn at Westertede, and the single station—half way along the line—is the house of a gentleman, who hospitably entertains the passengers while they are waiting for the train. The rolling stock comprises two small four-wheeled tank locomotives weighing (when in working order) seven and a half tons each; three carriages of the American type, with a door at each end; two open trucks and two covered. A train consists of the engine and two vehicles, between which the guard sits. There are no turn-tables, so that the locomotive is at the hinder end of the train in returning. The fuel employed is turf, which is abundant in the district. The receipts of this tiny railway are steadily increasing.

DIGITATED STOCKINGS.

From time immemorial stockings with toes have been used occasionally, particularly in the treatment of certain foot troubles. Lately they have come into more general use, and not a little public discussion has arisen over the fashionable novelty. The London medical authority, *Lancet*, is strongly inclined to favor them as likely to conduce to comfort, and spare many persons who now suffer from the development of soft corns between the toes, a serious trouble. "They would also be more cleanly than the stockings in common use, because they would naturally absorb and remove the acrid moisture which accumulates between the toes, and which is the general cause of offensive odors from the feet. They will, moreover, give the foot better play, allowing its phalanges greater freedom of action. And, lastly, a well-fitted digitated sock or stocking will remove a mass of material from the toe of the boot, and, at the same time, secure increased breadth and space for expansion across the base of the toes. The new stockings supposing them to be well cut and fitted, possess many advantages."

Even if the toed stocking should have no other effect than to expel the ugly and unphysiological "French-toed" boot, it would prove a public benefit.

THE PROSPECTS OF SILK CULTURE IN THE UNITED STATES.

The prospects of a large and healthy, though probably not rapid, development of the native silk industry in this country are now particularly bright, for three reasons:

1. The general prosperity of our people and the wide diffusion of wealth have been attended by, if they have not created, a large and steadily increasing demand for silk fabrics, as the annual importation of over forty million dollars worth of raw and manufactured silks amply demonstrates.

2. The rapid and stable development of silk manufacturing here during the past ten or a dozen years, and the probability that our manufacturers will not stay their efforts until at least the home market has been conquered. Our two hundred silk mills are already converting from ten to twelve million dollars' worth of imported raw silk into manufactured goods, worth thirty million dollars or more. In other words, there is now a home demand for at least ten million dollars worth of raw silk to encourage home production—a demand that has doubled in the past two or three years, and is likely to increase quite as rapidly in the future. The declining silk production of Europe, owing to diseases affecting the worms, indicates that we may, if we chose, compete with the East for that vast market also, certainly with respect to the supply of eggs and cocoons.

3. In all parts of the country, particularly in the South and Southwest, a lively popular interest in silk culture has arisen during the past five years, and hundreds are experimenting in that direction with encouraging results. The Women's Silk

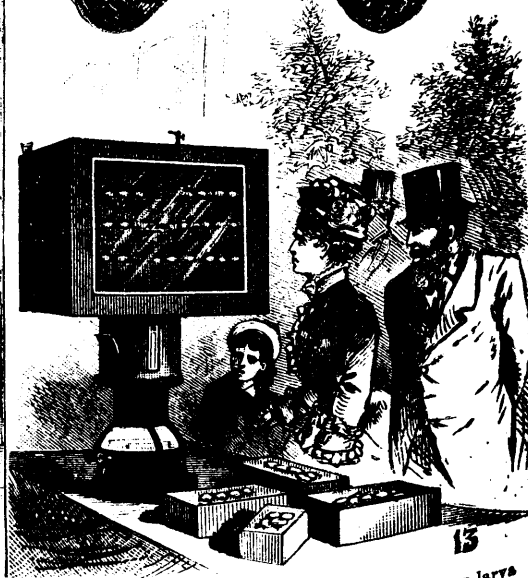
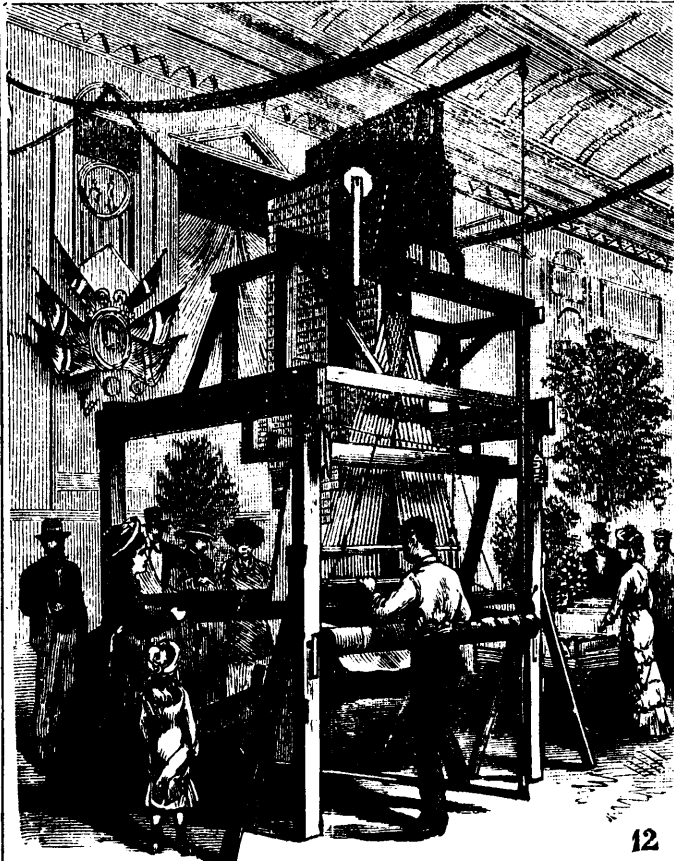
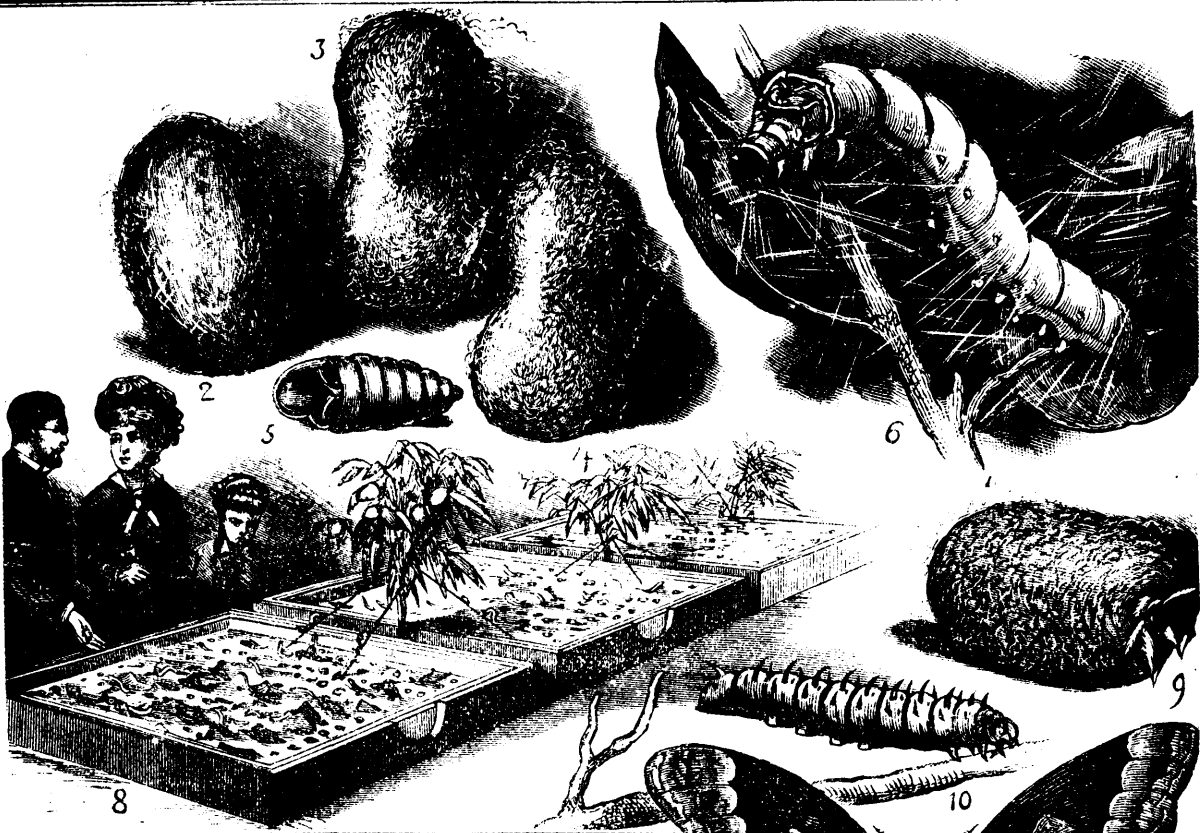

1. The moth and larvæ one and four days old.—2. 3. and 4. American, French, and Chinese Cocoons.—5. Chrysalis.—6. A full-grown larva spinning.—7. Bottles containing American Cocoons.—8. Breeding boxes.—9. Moth leaving Cocoon (natural size).—10. The ailantus moth and larva (half size).—11.—Reel and finished raw silk. —12. Loom.—13. Apparatus for loosening the silk threads from the Cocoons.

VIEW FROM THE SILK INDUSTRY EXHIBITION AT NEW YORK.

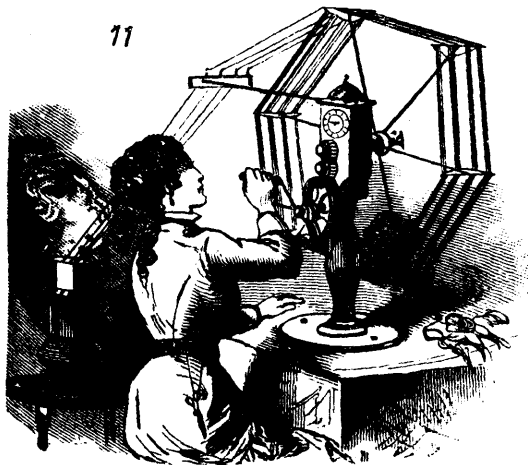
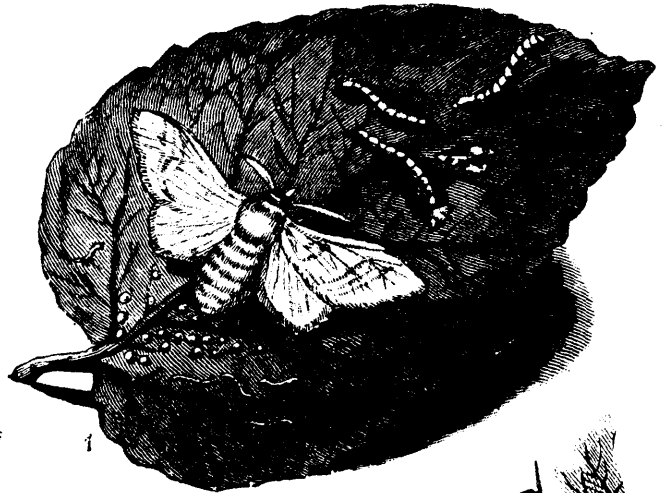

Culture Association of the United States, established only two years ago, reports over ten thousand correspondents. Trees and silk worm eggs—technically *grain*—have been sent by them to twenty-four States for testing local and personal capabilities for silk production; and American raw silk and grain have been submitted for critical tests in Turkey, Milan, and Lyons, winning such commendations as to prove that, if the question of cost can be as satisfactorily settled as that of quality has been, our silk growers need not fear competition in any quarter.

The question of cost is now the important one. The caring for silk worms is likely to be here, as it is almost everywhere where it prospers, a domestic enterprise chiefly employing the spare time of women and children during the early summer. The time available for such pursuits is now largely unoccupied; devoted to silk growing it would be so much clear gain; yet the industry must yield an enticing profit for the time devoted to it, compared with other possible occupations, or it will not command more than sporadic attention. Fortunately the number of those who are now trying their hands at silk raising is so great that the financial problems involved cannot remain long in doubt. If the stories of profit told by many of these experimenters are no more than half true the industry is bound to prosper, certainly in the South, where the conditions are most favorable.

The Women's Silk Culture Association, whose head-quarters are in Philadelphia, has been, perhaps, the most influential single agency, both in developing the revival of interest in silk culture and in keeping it from extravagance or anything tending to a repetition of the popular craze of forty years ago. The establishment of a new industry involving the intelligent action if not co-operation of thousands largely unfamiliar with

business methods, and unused to sustained painstaking labor, is not an easy undertaking; and the success already achieved through their efforts speak well for the soundness and prudence of the methods of the association.

The beginning of the revival was manifested during the Centennial Exhibition. The exhibition and training school organized in the Permanent Exhibition by the association gave it a new and powerful impetus, the influence of which was broadened by subsequent exhibitions of silk production at State fairs in Pennsylvania and New Jersey, and at the American Institute Fair in New York. The remarkably successful exhibition of the Women's Association in Philadelphia last spring added materially to popular knowledge of silk culture and the industrial inducements it offers. In the meantime a silk culture society has been projected if not organized in New Orleans, and establishments for the cultivation and distribution of silk worm eggs and trees for feeding worms have been established in or near various Southern cities. In New York a Silk Exchange has been organized for the purpose of furthering the silk industry, and during the summer an exhibition of processes of silk production and manufacture was maintained for several weeks. The accompanying engravings give several views of the materials and processes there shown. The contrast in size of the cultivated silk moth and some of our native moths yielding silk (and of their cocoons) is very great; yet none of the latter appears to yield so large a quantity of fine silk in condition to be readily unwound and reeled from the cocoon. It is quite possible, however, that by careful cultivation and selection there may ultimately come from our native moths insects which, in yield of silk, hardness, and general availability for this climate, will surpass the foreign moth as markedly as they already do in size and beauty.—*Scientific American*.

Miscellaneous Items.

THE EDELWEISS.

The curious and interesting Alpine plant, edelweiss, which travelers in Switzerland have so often carried away for its local and poetic associations, and have as uniformly failed in the attempt to cultivate it, has at last been reduced to cultivation by an English gardener. He treats the plant as a biennial, and raises a batch of seedlings every year. This year the seed was ripe July 25, and was immediately sown in a peat soil covered with a little silver sand. Ordinary seed pans were used. In a fortnight many seedling plants were above the surface and growing satisfactorily. The soil in the seed plants is kept moist, and the plants well shaded from the sun under the plant stage of a greenhouse. The young plants are kept in the pans all winter, then pricked off singly into small pots in March. In May they are planted out in a rock garden, where they grow freely and bloom profusely. Sand-stone appears to suit the edelweiss well; the roots seem to fasten themselves to it and produce vigorous plants. A position in the open sun appears to be best suited in England, to the well-being of the plant. In this country more shade would probably be necessary.

The demand for edelweiss has been so great among travelers in the Alps that several cantons have prohibited the sale of the plants, lest they should be entirely exterminated.

THE COST OF BOMBARDMENT.

Speaking of the monetary cost of bombarding the Alexandria forts the London Daily News says that every round fired from the four 80 ton guns of the Inflexible cost the nation £25 16s (about \$125) per gun. The 25-ton guns, of which the Alexandra carries two, the Monarch four and the Téméraire four cost £7 per round per gun. The 18-ton guns, of which the Alexandra carries ten, the Sultan eight, the Superb sixteen, and the Téméraire four, cost £5 5s. per round per gun. The 12-ton guns of which the Invincible carries ten, the Monarch two, and the Sultan four, cost £3 12s. per round per gun. The Penelope, which alone carries 9-ton guns, has eight of them which were discharged at a cost of £2 15s. per round per gun. The Monarch and the Bittern each fired a 6½-ton gun, the cost being £1 15s. per round per gun. The Beacon and the Cygnet have two 64-pounders each, the cost of discharging which is 18s. per pound per gun. The Penelope carries three 40-pounders, the Beacon two 40-pounders, and the Bittern two 40-pounders, the cost of discharging which was just 12s. per round per gun.

AN INTERESTING RELIC.

Some recent excavations in Berkley Square, London, England, brought to light one of those curious relics of Old London which are every now and then being exposed in its streets. In the sixteenth century, London was supplied with water from the Thames by means of wooden pipes, invented by one Peter Morris, or Maurice, a Dutchman, who, in 1580, obtained a right from the corporation to erect machinery to supply what many householders had been compelled to purchase, a tankard at a time, from the water-bearers. Maurice's works were erected at Old London Bridge, and his water pipes were hollowed out of the stems of trees, tightly fitted into each other, much after the manner of the common sewer pipe of to-day. Some wooden piping of the kind devised by this ingenious Dutchman has recently been dug up in Berkley Square, but it was probably a part of the New River Company, which so far adopted Maurice's plan that it originally supplied water through pipes formed of the stems of small elm trees, denuded of bark, drilled through the center and cut to lengths of about 6 feet. Some 19 years ago a considerable length of this wooden piping was exhumed in Pall Mall.

GOOD SERVANTS BUT BAD MASTERS.

With every new invention for the comfort and convenience of humanity, come new perils. Steam, that drags or drives us over the world at faster rates than the most imaginative of our grandfathers dreamt of, sometime hurries us out of it with the sweeping destruction of a plague. Gas, that turns our nights to day, bursting its bonds, asphyxiates us, and spreads flame in every direction. Within a few months numerous accidents, many of them very grave, caused by uncontrolled electric force

have been reported. Cases of permanent injury or serious wounds of long duration, inflicted by the impalpable and invisible fluid have occurred everywhere, on land and at sea. A sailor seizes the two wires of an electric lighting contrivance as it is being lowered into the hold of a ship and is instantly killed. The tragedy at Newport, is another terrible instance. Recently fires caused by the wires of electric telegraph, telephone or illuminating apparatus, have brought the matter to the attention of fire engineers and underwriters, who unite in warning people of the frightful risks that attend the use of these conveniences of modern life. The principal sources of danger, it appears, are wires not thoroughly insulated. The electric spark has been known to leave the wire at a point where the insulation was broken, and, leaping to a bit of metal for which it has an affinity, a nail in a roof, for instance, has set fire to a building. The dangers are increased by the necessity, especially in the case of the electric light, of employing strong batteries from which the wires are heavily charged with electricity. The only means of protection that have suggested themselves to electricians and others interested in the matter are the complete separation of electric light wires from those connecting telegraph apparatus, the thorough insulation of all wires, and an arrangement on the exterior of buildings for an absolute "cut-out," so that firemen, when brought in contact with the fires, may effectually prevent them for the time from conveying injury to life or property. The electricians, fire engineers and insurance experts, however, have yet to try how far by burying the wires the danger may be averted. The risk to life from lightning striking exposed wires is so well known that the lessees of telephones are cautioned against using them during a thunder storm, and devices for arresting the spark are set up in all telegraph stations. Certainly, risk from this source would be considerably lessened were the wires put beyond the reach of natural electricity.

HINTS TO SWIMMERS.

When a swimmer gets chilled the blood ceases to circulate in the fingers, the finger nails become a deathly white color, the lips turn blue, and should he persist in staying in the water after these symptoms develop he is sure to have cramps. So long as the swimmer can discern spots on his finger nails he knows that his blood is in good order, and that he is safe and free from chills. I have been remarkably free from chills, and feel most at ease when in the salt water under a hot sun. Salt water seems to attract the heat, and, no matter what the temperature of the water, under these circumstances I feel warm. I have on some occasions swum so as to keep my body under water, but even in such instances on coming out I have found my back and limbs blistered. This shows the penetration of the heat from the rays of the sun on the water. On one occasion, since I was here last, I swum for £400 at Scarborough, staying in the water seventy-four hours. I use a preparation of porpoise oil, which I rub all over my body, even my face. The oil fills up the pores of the skin and keeps the salt water from permeating my vitals. All professionals now use oil.—CAPTAIN WEBB, in *Boston Herald*.

OSCAR WILDE.

In a recent lecture, Mr. Oscar Wilde, the popular exponent of "Utterism," did not fail to show up some of our short comings in matters of taste. He described his impressions of many American houses, ill designed, decorated shabbily and in bad taste, and filled with furniture that was not honestly made and was out of character. His picture of cheerless rows of houses, glaring bill boards and muddy streets was equally graphic. He pointed out that this was the condition in America, whereas in England the artists and the handicraftsmen are brought together to their mutual profit. It is to be regretted that ridicule stifles many of the good things he advocates. As he justly declared, the two greatest schools of art in the world had their origin with the handicraftsman. Arguing from this, he pleaded for the establishment of a school of design in each city. He asserted that if decoration is a fine art, all the arts are fine arts. The real test of the workman is not his industry or his earnestness, but his power of designing. The surroundings of the handicraftsman in America are now meaningless architecture, sombre dress of men and women, and a lack of a beautiful national life. He would not have us build another Pisa, surrounding and inspiring Michael Angelo; neither would he have us bring back the thirteenth century, for

that would be impossible and wrong. But he would have an art teaching that would suit the nineteenth century.

Like Mr. Ruskin, Mr. Wilde has a horror of this mechanical age. He pronounced against machine made ornaments, as being ugly, coarse, and bad, as compared with beautiful and durable handiwork, but he wisely observed that he only objected to machines when making machines of operatives, and not when they relieve men from ignoble tasks. They must not mistake the material of civilization for civilization itself. It is the use to which we put these things that determines whether the telephone, the steam-engine, electricity, are valuable to civilization. The workmen require to be strong, have a healthy physique, and a sense of individualism, which is the keynote of art. The lecturer appealed for schools of design, and means of teaching art to the poor, so that they can beautify their homes. He did not want the rich to possess the more beautiful things, for they have enough. One might live in a whitewashed cottage with a fireplace set with red tiles, where an ill designed and vulgarly furnished house would be unendurable. Mr. Wilde gave many practical suggestions on household decorations and art studies.—*Builder*.

CURIOUS ARTIFICIAL FORMS OF SILICA.

Curious artificial forms of silica, which are interesting as illustrating the structure of agates and chalcedonies, are produced by Messrs. Anson & Dankhurst in the following manner. The method would appear to be susceptible of forming an interesting lecture experiment :

A strong solution of an alkaline silicate (water-glass) is taken, containing a certain amount of alkaline carbonate, and a strong acid (sulphuric is recommended) is introduced by means of a pipette to the bottom of the vessel in which the solution is contained. Bubbles of carbonic acid gas at once arise, carrying with them a certain amount of the stronger acid. Around the stream of ascending bubbles silica is deposited by the decomposition of the alkaline silicate, and in a few minutes a tube is formed reaching from the bottom to the surface of the solution. This tube is at first very thin, and through its walls the ascending acid continues to act upon the surrounding silicate, the walls of the tube in consequence constantly increasing in thickness by the deposition of additional silica on its outer surface. As long as the flow of acid is kept up, so long does the tube increase in diameter by the deposit of successive layers, and the result is a hollow stalactite ringed in cross sections.

The authors note that the action can be kept up until a tube of nearly one inch in diameter is formed by forcing the acid through the walls by applying pressure to the surface, and suggest a number of means whereby the process may be varied with the same results. They then proceed to state that the natural silicious stones like agate, chalcedony, etc., and in such minerals, where stalactitic forms occur, a central core of iron or other oxide is frequently observed, which, in the opinion of the authors, appears to represent the original tube, which has subsequently been filled up, while sometimes the cavity remains more or less completely as such. These stalactites, of course, do not grow up in regular forms, but are irregular in form, and branched more like those of coral than anything else, according to the direction taken by the gas bubbles in escaping from the end, or from points of least resistance along the sides of the tube. The authors consider that the banded stalactitic growths that occur so frequently with silicious minerals, have been produced in a manner very analogous to the stalactitic forms produced in their experiments. They have been able, by the use of acid solutions containing various metallic and earthy salts, to cleverly imitate the coloring of natural minerals, such as jaspers, moss agates, onyx, etc.; and they conclude that under suitable conditions of heat and pressure, natural agates and allied silicious minerals might be imitated, both in form as well as in hardness and stability.

The paper is published in full in the *Mineralogical Magazine*, current volume, to which we refer for many interesting details which we have been compelled to omit.

THE COLLECTION OF AMERICAN WOODS AT THE CENTRAL PARK MUSEUM.

The directors of the American Museum of Natural History are now preparing for exhibition in the Arsenal building, in Central Park, one of the finest collections of native woods ever

brought together. When rendered complete by the addition of 26 specimens that are expected to arrive before winter sets in, the collection will embrace specimen-blocks from each of the 420 trees indigenous to this country, and most of which have some economic or commercial value. As is usual in collections of this kind, each specimen-block is sawn longitudinally, diagonally, and transversely, so as to show the characteristics of the wood.

Among the many curious specimens in the collection now being prepared for exhibition, says the *New York Times*, one which will excite the greatest curiosity, is a specimen of the honey locust, which was brought here from Missouri. The bark is covered with a growth of thorns from one to four inches in length, sharp as needles, and growing at irregular intervals. The specimen arrived here in perfect condition, but in order that it might be transported without injury, it had to be suspended from the roof of a box car, and thus make its trip from Southern Missouri to this city without change. Another strange specimen in the novel collection is a portion of the Yucca tree, an abnormal growth of the lily family. The trunk, about two feet in diameter, is a spongy mass, not susceptible of treatment to which the other specimens are subjected. Its bark is an irregular, stringy, knotted mass, with porcupine quill-like leaves springing out in place of the limbs that grow from all well-regulated trees. One specimen of the Yucca was sent to the museum two years ago, and though the roots and top of the tree were sawn off, shoots sprang out and a number of the handsome flowers appeared. The tree was supposed to be dead and thoroughly seasoned by this fall, but now, when the workmen are ready to prepare it for exhibition, it has shown new life, new shoots have appeared, and two tufts of green now decorate the otherwise dry and withered log, and the Yucca promises to bloom again before the winter is over. One of the most perfect specimens of the Douglass spruce ever seen is in the collection, and is a decided curiosity. It is a recent arrival from the Rocky Mountains. Its bark, two inches or more in thickness, is perforated with holes reaching to the sapwood. Many of these contain acorns, or the remains of acorns, which have been stored there by provident woodpeckers, who dug the holes in the bark and there stored their winter supply of food. The oldest specimen in the collection is a section of the *Picea engelmannii*, a species of spruce growing in the Rocky Mountains at a considerable elevation above the sea. The specimen is twenty-four inches in diameter, and the concentric circles show its age to be 410 years. The wood much resembles the black spruce, and is the most valuable of the Rocky Mountain growths. A specimen of the nut pine, whose nuts are used for food by the Indians, is only fifteen inches in diameter, and yet its life lines show its age to be 369 years. The largest specimen yet received is a section of the white ash, which is forty-six inches in diameter and 182 years old. The next largest specimen is a section of the *Platanus occidentalis*, variously known in commerce as the sycamore, button-wood, or plane tree which is forty-two inches in diameter and only 171 years of age. Specimens of the red-wood tree of California are now on their way to this city from the Yosemite Valley. One specimen, though a small one, measures five feet in diameter and shows the character of the wood. A specimen of the enormous growths of this tree was not secured because of the impossibility of transportation, and the fact that there would be no room in the museum for the storage of such a specimen, for the diameter of the largest tree of the class is thirty-five feet and eight inches, which represents a circumference of about one hundred and ten feet. Then, too, the Californians object to have the giant trees cut down for commercial, scientific, or any other purposes.

To accompany these specimens of the woods of America, Mr. Morris K. Jesup, who has paid all the expense incurred in the collection of specimens, is having prepared, as an accompanying portion of the exhibition, water-color drawings representing the actual size, color, and appearance of the fruit, foliage, and flowers of the various trees. Their commercial products, as far as they can be obtained, will also be exhibited, as, for instance, in the case of the long leaved pine, the tar, resin, and pitch, for which it is especially valued. Then, too, in a herbarium the fruits, leaves, and flowers are preserved as nearly as possible in their natural state. When the collection is ready for public view next spring it will be not only the largest, but the only complete one of its kind in the country. There is nothing like it in the world, as far as is known; certainly not in the royal museums of England, France, or Germany.—*Scientific American*.

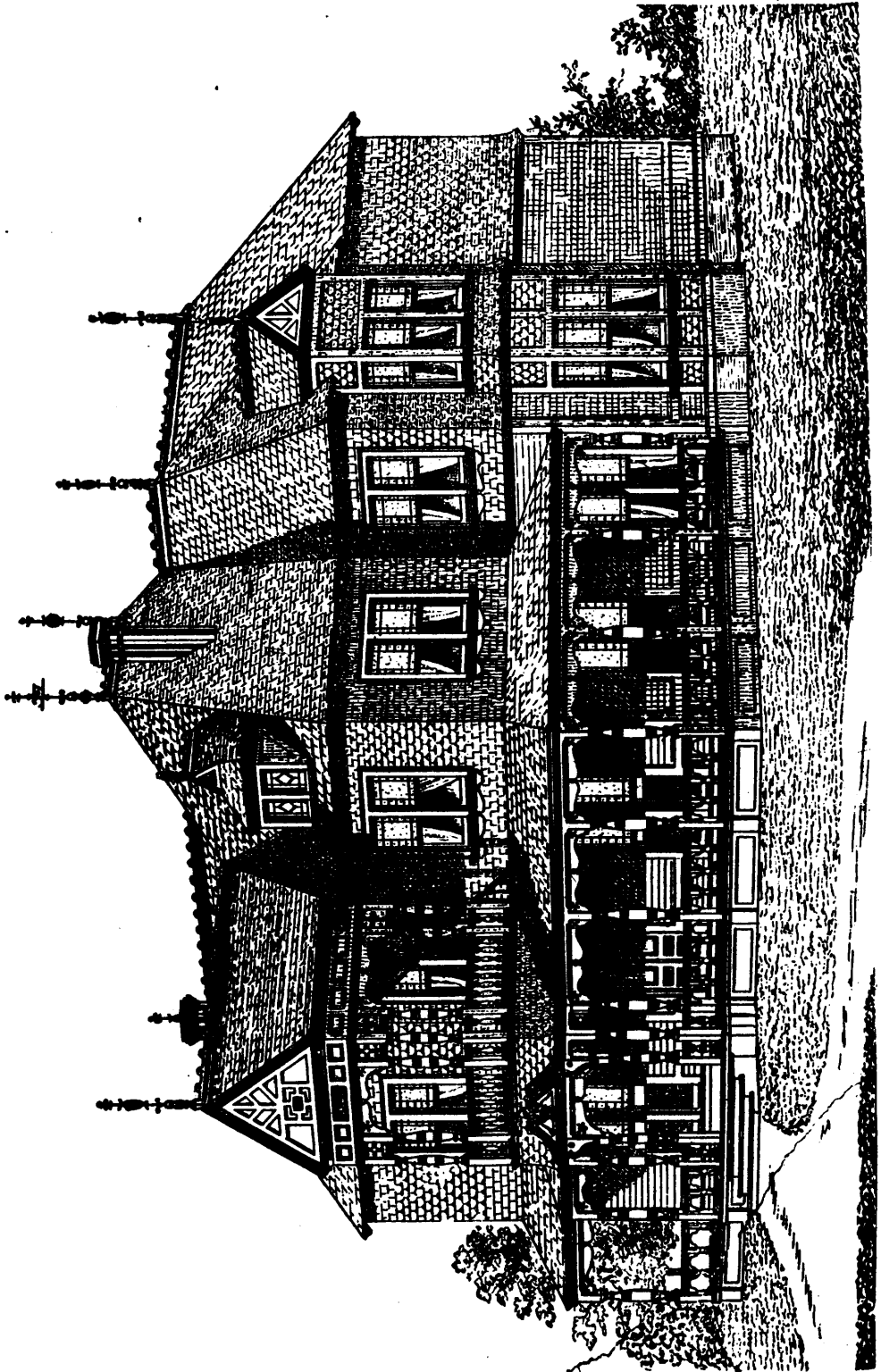

DESIGN FOR SUBURBAN RESIDENCE, COSTING \$8,500.—FOR PLANS AND DESCRIPTIONS, SEE NEXT MONTH.