

Technical and Bibliographic Notes / Notes techniques et bibliographiques

The Institute has attempted to obtain the best original copy available for scanning. Features of this copy which may be bibliographically unique, which may alter any of the images in the reproduction, or which may significantly change the usual method of scanning are checked below.

L'Institut a numérisé le meilleur exemplaire qu'il lui a été possible de se procurer. Les détails de cet exemplaire qui sont peut-être uniques du point de vue bibliographique, qui peuvent modifier une image reproduite, ou qui peuvent exiger une modification dans la méthode normale de numérisation sont indiqués ci-dessous.

- | | | | |
|-------------------------------------|---|-------------------------------------|---|
| <input type="checkbox"/> | Coloured covers /
Couverture de couleur | <input type="checkbox"/> | Coloured pages / Pages de couleur |
| <input type="checkbox"/> | Covers damaged /
Couverture endommagée | <input type="checkbox"/> | Pages damaged / Pages endommagées |
| <input type="checkbox"/> | Covers restored and/or laminated /
Couverture restaurée et/ou pelliculée | <input type="checkbox"/> | Pages restored and/or laminated /
Pages restaurées et/ou pelliculées |
| <input type="checkbox"/> | Cover title missing /
Le titre de couverture manque | <input checked="" type="checkbox"/> | Pages discoloured, stained or foxed/
Pages décolorées, tachetées ou piquées |
| <input type="checkbox"/> | Coloured maps /
Cartes géographiques en couleur | <input type="checkbox"/> | Pages detached / Pages détachées |
| <input type="checkbox"/> | Coloured ink (i.e. other than blue or black) /
Encre de couleur (i.e. autre que bleue ou noire) | <input checked="" type="checkbox"/> | Showthrough / Transparence |
| <input type="checkbox"/> | Coloured plates and/or illustrations /
Planches et/ou illustrations en couleur | <input checked="" type="checkbox"/> | Quality of print varies /
Qualité inégale de l'impression |
| <input checked="" type="checkbox"/> | Bound with other material /
Relié avec d'autres documents | <input type="checkbox"/> | Includes supplementary materials /
Comprend du matériel supplémentaire |
| <input type="checkbox"/> | Only edition available /
Seule édition disponible | <input type="checkbox"/> | Blank leaves added during restorations may
appear within the text. Whenever possible, these
have been omitted from scanning / Il se peut que
certaines pages blanches ajoutées lors d'une
restauration apparaissent dans le texte, mais,
lorsque cela était possible, ces pages n'ont pas
été numérisées. |
| <input checked="" type="checkbox"/> | Tight binding may cause shadows or distortion
along interior margin / La reliure serrée peut
causer de l'ombre ou de la distorsion le long de la
marge intérieure. | | |
| <input checked="" type="checkbox"/> | Additional comments /
Commentaires supplémentaires: | | Continuous pagination. |

CANADIAN MAGAZINE

OF

Science and the Industrial Arts.

Patent Office Record.

Vol. 13.

OCTOBER, 1885.

No. 10.

Communications relating to the Editorial Department should be addressed to the Managing Editor, P. O. Box 128, Montreal.

Business communications and subscriptions to be sent to the Burland Lithographic Co., Montreal.

The Editor does not hold himself responsible for opinions expressed by his correspondents.

No notice will be taken of anonymous communications.

SMALL-POX AND VACCINATION.

Contagion is very often capricious, but the contagion of small-pox is by far the most virulent, excepting cholera, which we have to deal with, and but for the immortal discovery of Dr. Jenner would perhaps have continued to prevail as one of the most terrible scourges of the human race.

Montreal at the present time is afflicted with this unwelcome trouble, but if the truth were told perhaps small-pox is hardly ever completely stamped out there, owing, no doubt, to the unconcerned and inconsiderate behaviour of a large class of her population.

People of the present day who complain of the temporary inconvenience and slight danger of vaccination, are only doing so through superstition and ignorance of the horrible suffering, disgusting deformity, and terrible mortality which attended small-pox in former times, previous to the discovery of vaccination.

In the 18th century the mortality was so great that one out of every four died of this disgusting malady, and when we consider that every one seized with it became immediately an object of danger, dread and loathing, even to his or her dearest friends, and if recovery took place was, as a rule, generally rendered repulsive for life. We can even in a small measure realize what a blessing Jenner's discovery has been to the world.

In walking the streets of Montreal, a stranger is soon struck with the evidences of small-pox, and may be told casually that the French population, with perhaps some exceptions, do not look upon the disease with such holy horror as their English-speaking neighbours, and are, in consequence, less careful in preventing contagion.

The contagion of small-pox is extremely active, if not carefully and studiously guarded against. It may spread rapidly through a house and to neighbouring

dwellings, although in many cases it may attack only one member of a large family and all the others escape. But the surest and best known method to avoid contagion is to be vaccinated and re-vaccinated if the disease happens to be prevalent. Re-vaccination is necessary because, although in a majority of instances, a single vaccination, if perfect, protects through life, and always prevents fatal or deformed results, if attacked by the disease, in a minority of cases this security becomes less and less with advancing years, or where a person's system has undergone such changes as to have completely thrown off the effects of the virus injected when a child. And as yet we have no means of distinguishing those individuals; consequently it is safest and best to revaccinate for the public and personal good.

We could easily quote from history many facts in favour of vaccination and the vaccination laws, but leave that for others to do, and merely close by summarizing the experience of the 18th and 19th centuries, viz.:

1st. The great means whereby small-pox may be wholly exterminated, at least as a loathsome and dangerous disease, is universal vaccination.

2nd. Small-pox is one of the greatest curses of man, whilst vaccination, under these circumstances, is one of his greatest blessings.

FALL EXHIBITIONS.

When going to press Ontario is in the midst of her usual fall exhibitions.

London Exhibition was in point of Exhibits very good, but the receipts, owing to several wet days, will doubtless fail in meeting the large expenditure which was incurred to make the Provincial fair a great success.

The Governor-General opened the exhibition, and was received all round in the kindest and most gracious manner; his short rule already in Canada has endeared the people to him as an honest constitutional governor of the Crown. His speech referred to the very striking difference in all commercial and agricultural statistics in favor of Ontario as compared with the entire Dominion. Perhaps he could with equal justice have declared that Ontario was also the milch-cow of the Dominion, but his position precludes stating the whole truth.

Toronto's great fair is in full blast, and although at the first the weather was unfavorable, she will doubtless have the usual good luck of fine weather. The Industrial Association Co. have spared no pains in giving permanence to this fair, which is now looked upon as Ontario's best and largest fall attraction. Hundreds of thousands of people flock yearly to Toronto during exhibition period from all quarters to see the sights and learn of the progress in every trade and industry.

Toronto's fair is largely made up of the three features, viz., interest, instruction, and amusement, so that all classes of people may be amply satisfied in one or all departments.

The directorate of this Institution is made up of some of Toronto's most pushing men, with Manager Hill among them, and President Withrow at the helm.

We will have an opportunity in our next issue to say more, practically, of the exhibits, and for the present hope that this year's fair will prove to be at least as successful and even more so than any of its predecessors.

TORONTO'S NEW PUMPING ENGINE.

The new pumping engines, over which so much talk and feeling existed, are at last finished, and have been in operation at intervals.

It will be remembered that we took great exception at the time to the proposed design, chiefly on the point of economy, because the supplying of an important city with water, at the lowest possible cost, is one of the essential requirements.

The city newspapers, especially, the *Telegram*, which was the original champion of the design, made mention lately of the great success of the test of these engines, but it goes without contradiction that they had not the slightest grounds for making such a statement.

We know positively well that the pumping engines can never be, in the very nature of things, a success; and it is terribly humiliating to think that a progressive city like Toronto has been so shamefully bulldozed and hoodwinked.

Very few figures and facts have yet been made public, but those that have been clearly demonstrate that the duty will be considerably below what was even guaranteed by the contract.

It is very doubtful if a correct test can ever show a duty of 60 million foot pounds for every 100 lbs. of coal consumed, whereas the guaranteed duty is only 70 million; a duty which, under the circumstances, in these days is shamefully small.

The whole contract will stand as a humiliating and expensive monument of Toronto's foolishness, and a lasting disgrace to those who, in seeking to direct the city's interest, presumed too far.

There must be something terribly wrong in Toronto, when her engineering official advisers deliberately hoist such an engine on to the Water Works Department, because the most elementary knowledge of steam engineering and the principles of mechanism would suffice to prove by simple practice, theory and calculation, that the design adopted would result in failure, and could only give a little better duty than the present notoriously bad Worthington steam machinery in use.

The citizens of Toronto will doubtless look to the recently appointed Water Works' manager, who is care-

fully supervising the official test in the city's interests, for an honest verdict.

Some idea of the probable great yearly loss to the city by the usage of bad and uneconomical steam pumping machinery, may be gleaned from the fact that the cost of coal required alone may be about \$40,000, whereas with effective machinery this item alone could be reduced to about \$20,000; then other savings incidental on this would in all likelihood reduce the total expenditure at the pumping station to more than \$30,000.

For the present we leave this matter where it stands, and hope against hope for the city's test.

ENGLAND'S COLONIAL TRADE.

It is a fact requiring little demonstration that one of the chief factors of England's present industrial stagnation, is that those foreign countries which used to be her best customers, have not only learned to supply themselves, but in some instances have become rivals in many departments of trade.

Although England's Colonies are beginning to do much for themselves, they still import largely from the parent Country. England may congratulate herself that she enjoys the bulk of this trade of Colonial importation, but that she will always retain it becomes a question of the greatest moment.

The United States, although not now a colony, contribute more to the support of British manufacturers, and that the consumption there of even \$3.00 per head, represents a considerable sum, but the United States are getting on a par with Britain, and in some cases ahead, while for resources and internal trade, she has no equal.

The ties of blood or more close political relationship appear to be stronger incentives to purchase in the parent market,

In Canada the consumption of British manufactured goods is about \$15.00 per head, while in Australian colonies, it is about double. India and other dependencies must also contribute largely to the English export trade.

In Canada here, we feel that the Mother Country should do something in return for the industries of her children who show so much loyalty and good feeling towards her. England, in return, thinks this could only be accomplished by giving Canada and other colonies a preference tariff over other markets of supply, which would be nothing short of protection, and the first abandonment of England's mighty free-trade principles—rendered all the more impossible when the nature of the commodities affected by such a policy is considered.

Now, although England's commercial flag is "free-trade" and markets free to all, these theories do not represent facts actually and absolutely as they are,—for example, the excise duties are still deemed necessary for the national revenue, and surely it is not unreasonable to expect for the Colonies more favorable terms than foreign neighbours, when it is known that distance and other disadvantages militate against them.

The Colonies, England must admit, have claims upon her that no foreign country can pretend to, and what is really wanted is some practical recognition.

There can be no doubt that the encouragement of Colonial produce would lead to an increase in British exports.

It is certainly not inconsistent with Free Trade principles to render the Custom House barrier as easily surmountable as possible, especially between members of the same family.

If England, by treaty with France and Spain, seeks to do so by express stipulations, it stands to reason she ought to extend at least the same privileges to those who are bound to her by the closest ties of nationality and blood,—indeed, a refusal to allow her children some preference is manifestly unjust and cruel, and, if persistently continued in, will have the effect eventually of producing separate and independent States, or in some cases annexation to other Powers, and in no case would this transpire so readily as in Canada, which borders on one of the greatest republics that ever existed—a republic which in every way so readily suits us.

We call attention to our series of illustrations, with full particulars for the constructing and fitting up of laboratories in schools where science is designed to be taught. Although chemistry is chiefly the object of the design, other branches of science may profit by the laboratory.

The whole arrangement and design will be found complete and thorough in detail, being an exact counterpart of the requirements of the South Kensington Science and Art Department, London.

For the benefit of educationalists we intend reviewing occasionally the operations of this department, and will give sample examination papers on various subjects, some of which will be profusely illustrated, and we trust same will be both interesting, instructive and beneficial to a large number of our readers.

FITTINGS FOR LABORATORIES.

The drawings referred to in this memorandum are issued for the guidance of Committees of Schools in fitting up working Laboratories.

They should not necessarily be followed implicitly in all details, but are intended to show the amount of accommodation which should be provided for students.

Plate I. Shows a working bench for 4 students, two working on each side. It will usually be found advisable to place it "end on" to a window, so that the students may have the light at the side. The benches may be made to accommodate 6 or 8 students instead of four; but in no case should the space for each student be made less than 3 ft. 6 in. x 2 ft. 3 in. For benches placed against the wall, the same pattern divided longitudinally down the middle will serve.

Each student will require about 6 or 8 feet run or shelving for re-agents. This should be provided in the way shown in the drawing, each student's re-agents being kept in a distinct set of shelves. It is desirable to enclose these with sliding doors in order to enable each set to be locked up, and to keep out dust, etc. These doors may be glazed or panelled with wood.

Gas should be laid on to each student's place, nozzles being provided for fixing flexible tubes and a jet light to each. A basin and water taps should be provided for every two students. These basins should be placed either on the benches between the students, or at the ends. Both arrangements are shown in the drawing. Two drawers should be provided for each student under the table top, and the space below should be fitted with shelves and enclosed with cupboard doors, which should be set back a few inches to allow of the students sitting to their work.

The waste pipes from the basins are shown, not connected directly with the drains, but discharging into stoneware receivers emptying by overflow. By this arrangement the risk of stoppage of the drain pipes by rubbish, or their corrosion by strong acids, is avoided; and mercury accidentally upset into the basins can be recovered. Under any circumstances, how-

ever, the waste pipes should be so placed as to be easily accessible for repair.

Plate II. Shows a niche, or closet, for work evolving noxious fumes. The number of these to be provided must depend upon circumstances; but probably one to about 6 students will be found sufficient. They should be placed against the wall and connected with proper flues in order to ensure the removal of the fumes. Air may be admitted into them by holes in the door or by a space under the door. The connection with the flue should be made with earthenware pipe, and should be so arranged that dirt or moisture from the flue should not be likely to fall into the closet. The gas jet provided for maintaining the draught should be formed of copper pipe, as iron becomes corroded and the scales are liable to fall into any preparation in the closet.

Plate III. Shows a hood for a Hofmann's combustion furnace. It may also be found useful for other operations, which, from the size of the apparatus employed, cannot be performed in the small closets. It should be provided with a flue for taking off the fumes evolved.

Plate IV. Is a sketch of a lecturer's table. This should be at least from 10 feet to 12 feet long and from 2 to 3 feet broad. It is important that the surface of the table should be level and flush, and free from any obstruction.

A lead-lined trough should be provided at one end, covered by a movable part of the table top. A small sink, covered by a hinged portion of the table top, should be provided for emptying and washing apparatus. Taps for the supply of gas or water for experiments conducted on the table should be fixed a few inches below the top, and holes should be made in the edge of the table, as indicated in the drawing, for passing the flexible tubes fixed to the taps, by which arrangement they are not so liable to be disturbed as if they were passed over the edge of the table. It is convenient also to have terminals from a battery fixed in a similar position; the battery itself being placed in a position where its fumes will not be a nuisance.

The table should be lighted by lights suspended over it; or, if this cannot be arranged, by standard lights fixed near the front edge of the table, and these should be screwed on to sockets so that they can be taken away when not required.

In the wall behind the table should be a closet, 4 or 5 feet long, enclosed with a glazed sash and ventilated by a flue in which the draught should be maintained by a gas jet.

Black boards should be fixed against the rest of the back wall and arrangements should be made for hanging diagrams on the wall.

It is convenient to have a draught pipe from the surface of the table so that operations may be performed, in view of the students, under a glass bell, the fumes evolved being removed by the pipe which should be in connection with a flue and should be closed with a plug when not required.

METALLURGY.

In most cases, comparatively small additions to the chemical laboratories, arranged and furnished in accordance with the above regulations, will enable Practical Metallurgy to be taught.

It is necessary that a wind furnace should be provided, and this furnace must be in connection with a flue at least 30 feet high. The furnace may be placed in a basement below the laboratory, but there is no objection, if space permits, to its being in the laboratory.

There must also be a muffle furnace capable of heating to bright redness a muffle at least 8 inches long, 4 inches wide, and 3 inches high; when there is an abundant supply of gas, gas muffle furnaces, such as are supplied by Fletcher, of Warrington, or Griffin, of London, may be adopted with advantage.

The muffle furnace should be in the laboratory, as it is also useful in conducting various chemical operations.

Plate V.—Shows a vertical section of an air furnace which may be employed for all operations conducted in crucibles. It must be in communication with a chimney at least 30 feet high. Several such furnaces may be connected with the same chimney by means of a horizontal flue, but each furnace must be provided with a separate damper.

The internal portions of the furnace, most exposed to heat, are of firebrick and the admission of air is regulated by a regulator.

Plate VI.—Is a vertical section through a muffle furnace of the form and dimensions used in the Metallurgical Laboratory of the Royal School of Mines.

FITTINGS FOR CHEMICAL LABORATORY.

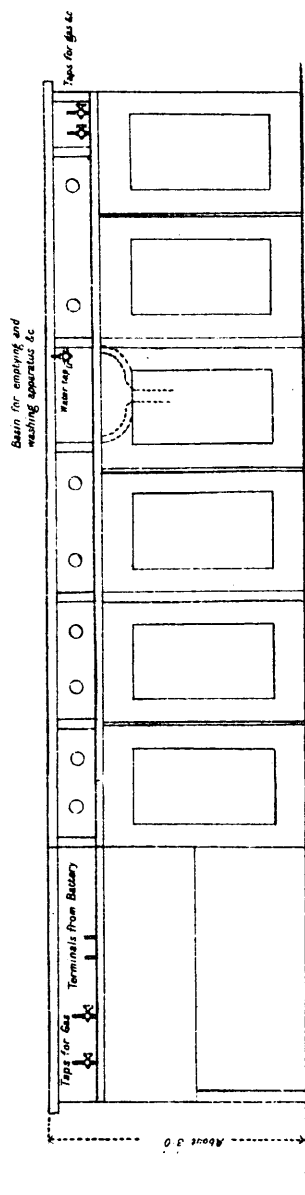

ELEVATION.

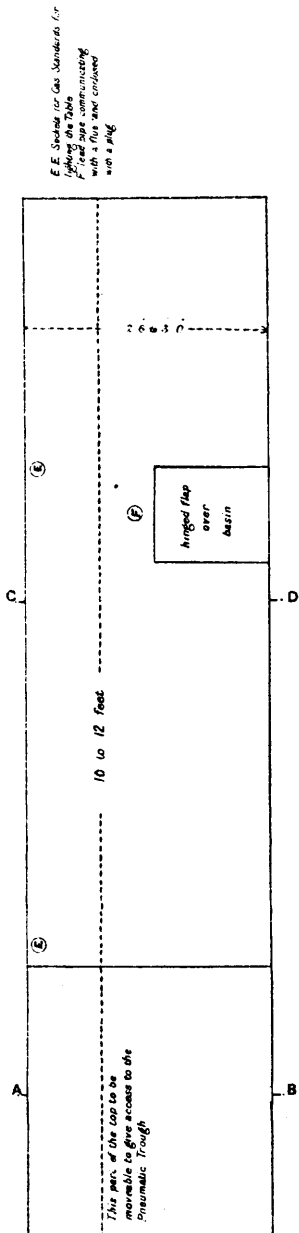

PLAN.

SCALE OF FEET.

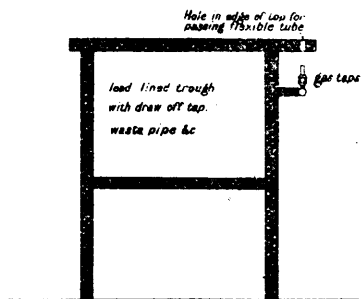
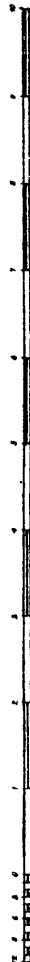

SECTION ON A. B.

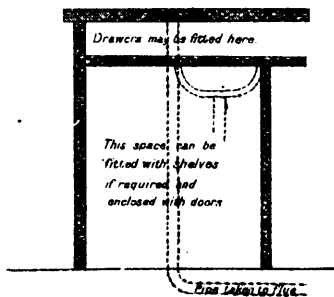

SECTION ON C. D.

FITTINGS FOR CHEMICAL LABORATORY.

WORKING BENCH FOR 4 STUDENTS.

Teak, or some hard wood, is best for the top, but good yellow deal will do. The rest may be of about the space for each Student should be at least 3'6" long by 2'3" wide. Gas should be laid on a rack piece and there should be a meter and sink for every two students. The water taps should have long tapered nozzles.

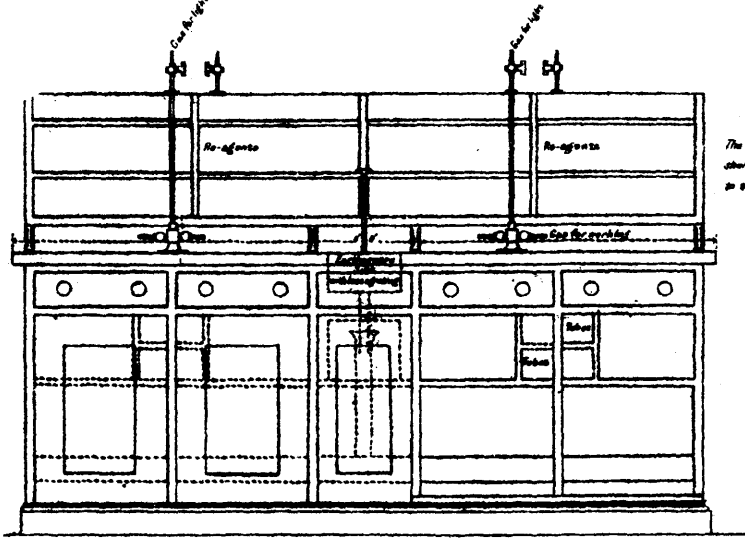

FRONT ELEVATION.

The distance apart of shelves is to be adjusted to the bottles used.

Alternative arrangement of sinks and water taps at the ends of the bench instead of in the middle.

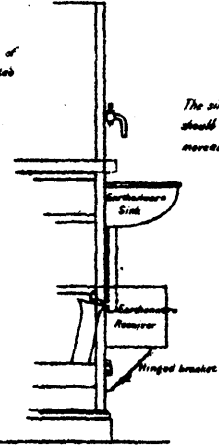

The sink and receiver should be enclosed with moveable casing.

SCALE OF FEET.



A

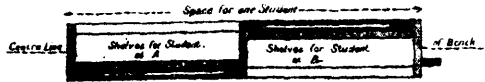

B

Plan of Hanging Shelves provided with sliding doors

*The receiver under the sink must be made with a lip not made fast to the waste pipe but merely to overhang it. The waste pipe should have a flange top and be twice the size of the pipe from the sink.
The receiver should be supported at the back on a slip of wood and towards the front by two moveable pins (or brackets) so as to be easily removed.*

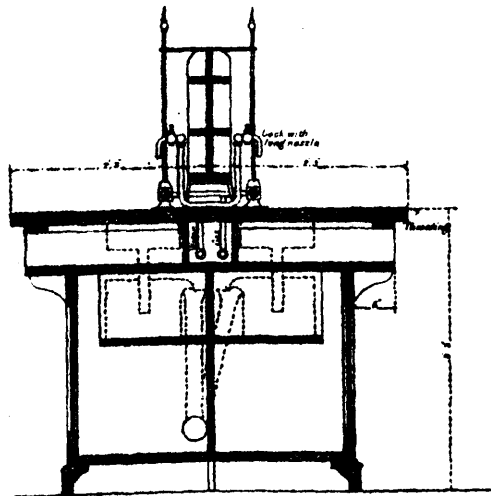

SECTION



The muffle, which is a short tunnel-shaped appliance closed at one end, need not be of the dimensions indicated, as various sized muffles may be fitted to suit various operations.

The front of the muffle should be closed with a tile or with a movable block which may be readily cut off from the soft red Windsor bricks. This block may be divided horizontally into two portions.

In both the air and the muffle furnace coke is the fuel used, the lighting of the furnace being started by a little charcoal. In both furnaces Anthracite may be used when an intense local heat is required.

The drawing shows that both furnaces are provided with top plates of cast iron. Such furnace tops are very useful as they consolidate the furnace and present a smooth surface which facilitates the working of the movable slabs by which the openings are closed, but they are not absolutely necessary and may be omitted.

THE NEW BANK NOTE PAPER,

MADE BY CRANE & CO., DALTON, MASS.

The manufacture of the "distinctive" bank note paper for the United States government, with its distributed silk fiber and parallel silk threads, has come to an end, and in a short time the Government mill of Messrs. Crane & Co., at Dalton, Mass., will be running on a new bank note paper that the Secretary of the Treasury has adopted. The old "distinctive" paper with parallel silk threads was the invention of Z. Marshall Crane, of Crane & Co., who first made the paper in 1844 for a bank in Northampton. Its use by state banks spread throughout New England and other parts of the country as a device against counterfeiting. Mr. Crane's idea was to put in one colored thread for a \$1 bill, two for \$2, three for \$3, four for \$5, five for \$10, and so on.

After the establishment of the national banking system, the government adopted the use of a "localized fiber" paper, which was somewhat distinctive, and was made in Pennsylvania. In 1879 the contract for making this paper was let to Crane & Co., whose "distinctive" paper with the distributed colored silk fiber, in addition to the colored silk threads that had so long been in use, so found favor with the Hon. John Sherman, then Secretary of the Treasury, that he issued an order, dated June 10, 1879, that it be adopted. About that time a man, who found that it had never been patented, made haste to get a patent in his own name, and at once disputed the right of Crane & Co., to manufacture the paper. What seemed a foolish farce at first, became more serious with the persistence of the patentee's fight, and Crane & Co., wrote to banks that had bought their paper many years before, asking them for samples of the same, if any old bills had been saved. The National Mahaim Bank of Great Barrington, Mass., had saved a \$3 bill, issued when it was a state bank, dated in 1847, and printed on the "distinctive" paper. The Bay State Bank of Lawrence also contributed a sample of early date. The patent therefore became void, because of prior common use, and Messrs. Crane & Co. went ahead in 1879 and made the paper in question, which they have made ever since until last spring.

Secretary Manning appointed a committee, not long ago, to investigate the subject and report upon the most preferable paper for bank notes, checks, etc., and this committee was so unfavorable to the "distinctive" paper that an order was issued for its abandonment and the adoption of a paper of better quality, with a bare trace of distinctiveness. A part of this order reads as follows:

The paper for United States notes, national bank notes and certificates is a white bank note paper, glazed on both sides, and its distinctive feature is the introduction of a blue silk thread into the body of the paper white in the process of manufacture, which shall run lengthwise through each note or certificate. A similar distinctive paper, with one or more blue silk threads, as the Secretary of the Treasury may determine, running through each sheet, is adapted for the other obligations of the government, except checks, drafts and stamps. A distinctive paper of similar character, with either a blue silk thread or water-mark, U. S. T. D., so placed therein that it may show upon each separate check or draft is adopted for United States checks and drafts.

The Secretary of the Treasury hereby gives notice that these distinctive papers, together with those heretofore adopted for the printing of the obligations or other securities of the United States, are and will be subject to the provisions of Section 5, 430

of the Revised Statutes, which reads as follows: "Every person * * * who has or retains in his control or possession, after a distinctive paper has been adopted by the Secretary of the Treasury, for the obligation and other securities of the United States, any similar paper adapted to the making of any such obligations or either security, except under the authority of the Secretary of the Treasury, or some other proper officer of the United States, shall be punished by a fine of not more than five thousand dollars, or by imprisonment at hard labor not more than fifteen years, or by both."

The only distinctive feature now is the blue thread, which is made so small as to be hardly visible; it is said that a pound of it will reach 150 miles. The contract for making the new paper has been let to Crane & Co., who have been famous bank note manufacturers for many years. All the bank note companies in the country buy paper from this firm, and those firms furnish money made of this paper to the South American governments, to at least one European government, to Canada and to other countries. The best of stock is used in this paper and the wash water, coming from a spring 1,000 feet above the mill on the mountain side, is not excelled for purity. The Government mill, recently visited by a representative of THE PAPER WORLD is supplied with every machine and convenience needed, but the product is small, for high quality rather than quantity is the desideratum. The mill has no superintendent, but its affairs are looked after by W. Murray Crane, one of the members of the firm, the others being Z. M. Crane and James B. Crane.

From 6,000,000 to 8,000,000 sheets of the old "distinctive" paper, weighing about 50 tons, are left, and these will all be used before the new paper. The manufacture of bank note paper here has already been described in THE PAPER WORLD, and it is sufficient now to say that each sheet, cut to the dimension of 8½ by 13½ inches, is counted automatically as it comes off the machine. The paper is then carried to the loft and dried then finished, finally counted by Crane & Co., and then delivered to the government employes. They examine it for quality, count the sheets again, and send them by express to the printer 20,000 sheets in a case, sealed and iron hooped. The imperfect paper is pulped, and all work is done in presence of government inspectors.

The main reliance of the government in this new paper against counterfeiting, is to be in the excellence of the engraving rather than in "distinctive" paper; but while this may do for the few exports, the mass of the people will not be so well protected as before, though, as a matter of fact, very few handlers of paper money ever pause to examine its "distinctive" features. However, in case suspicion is aroused that a bill is a counterfeit, people who are not experts never had a better test than the silk fibers and threads, and in the case of the new paper money they must now get a microscope and hunt it up the solitary blue thread.

CONFEDERATE MONEY.

The Confederate government did not lack for money. In 1861 it issued \$100,000,000, and until the last year of the war continued to send out bills of every convenient denomination, from \$1,000 to 25 cents. There were green 5-cent postage stamps with profile of Jefferson Davis on them, and these were sometimes used in making "change," but the man who did it was always pitied as a penurious, rascally fellow. Confederate money is handsome. Of course the paper is inferior, but some of the designs are well executed. It has a blue back, on which are intricate curves and circles and curls, and its value denoted by a single word in letters an inch and a half tall. There is no uniformity in the designs. On some bills there will be imaginary heads and sketches, a woman, a pile of arms, a rush to battle. On others appear likenesses of Confederate heroes and Confederate state houses,—as Jefferson Davis on the fifties and Alexander H. Stephens on the twenties; the Nashville, Tenn. state house on the tens and the Richmond, Va., state house on the fives. The face of Confederate money is colored pink around the likenesses. The first bill were simple notes, payable in six months. The second and all subsequent issues were made payable at different times "after a ratification of a treaty of peace between the Confederate States of America and the United States."

Confederate money was not long in going below par. During the war it was not the extortion of merchants which ran up prices to fabulous figures, but it was the depreciation of the currency. In some sections calico sold for \$10 a yard, good

shoes at \$30 and \$100 a pair. Fifteen dollars would purchase a spool of thread or a paper of pins. Medicines and all luxuries were not in the market for that sort of paper. A silver dollar was worth at least thirty Confederate dollars. The Confederacy understood that it had to protect its currency as well as its rights, and an act was passed making it treason for moneys to be exchanged at different values.

There has never been a craze among the curiosity collectors for Confederate money. The \$1,000 bill is scarce, and readily finds buyers at \$2 or \$3 each; the \$500 bill can be bought for 20 or 30 cents, the other denominations can be had for a song. Soon after the war men and women began to know for a certainty that their money was valuable only as paper. The ingenious housewives began to use it as money never before was used. They would paper their walls with old journals and periodicals, and put on a border made of Confederate money. Screens were made of bonds with money borders—in fact, everything susceptible of ornamentation received its supply of paste and pink treasury notes.—*Cincinnati Enquirer*.

A VESSEL OF NEW DESIGN.

No event in the last 20 years has created so profound and widespread an interest among shipping merchants, steamboatmen, and yachtsmen, as the performance of the little steam yacht *Stiletto* in beating the fast steamer *Mary Powell*. The *Stiletto* was built by the Herreshoff Manufacturing Company, of Bristol, of which John B. Herreshoff is president, and N. G. Herreshoff superintendent and designer. She was launched in April. John B. Herreshoff says that the hull of the *Stiletto* is the product of a series of experiments made with models, in the same manner as was followed by Froude, the English ship-builder, and of the improvements suggested by tests of the numerous steamers previously built by the Herreshoff company. Her length over all is 94 feet: beam, 11 feet; depth of hold in the centre, 7½ feet. Below the water line both ends of the craft are very nearly alike, being modelled so as to present the smallest possible surface exposed to the water with a given flotation, as in the attainment of very high speed "skin," or water surface friction is the factor of major resistance. The lines of the bows are very nearly straight, and the bottom is made in round sections. The slight slope of the deck forward and the more pronounced slope aft from the centre, which gives the peculiar appearance so noticeable in the boat, as well as the inclination inward are given merely for the purpose of getting rid of unnecessary weight in the hull, consequent loss of deck room being a matter of no moment in a boat of this kind.

The engine is designed to produce the greatest amount of power with the least possible amount of vibration. It is an annular valve inverted compound engine. It has two cylinders, one of 12 inches and the other of 21 inches diameter, with 12 inches stroke of piston. With maximum steam pressure of 150 pounds it will make 450 revolutions per minute, and is capable of working with that high pressure and high number of revolutions with very little wear and very liability to break down. The space required for it is very much smaller than that occupied by any other engine in use of the same power. The ordinary yacht engines are capable of making only from 175 to 225 revolutions per minute. The essential feature of the engine is in the construction of the cylinder, which consists of one cylinder within the other, with an annular space between in which the valve works. The steam ports, or openings through which the steam enters the inner cylinder, are ranged all around it at the top and bottom, so that the steam pressure is exerted on the piston head from all sides at once, and not as in the engines in use now from only one side. The *Stiletto* has made 25 miles an hour.

THE MANUFACTURE OF OXYGEN.

The chemical wonder of the London Inventions Exhibition, the manufacture of oxygen by the process of Brin Frères, is thus described: They have made what is really an artificial mineral lung of anhydrous oxide of barium, and with this, by an ingenious process, they simply take up the oxygen from the atmospheric air. They decompose the air, so to speak, and absolutely do what they like with it. First the air is drawn by means of a partial vacuum through a vessel of quicklime, which absorbs all the carbonic acid and moisture and reduces it to a mixture of oxygen and nitrogen. These gases are

then drawn into the retorts heated at 500°, and the artificial lung absorbs the oxygen, while the nitrogen is drawn off to a gasometer for conversion into ammonia, etc. The novelty is in the manufacture of the artificial lung. The Brins for the first time have made this indestructible. The use of baryta for the purpose is not unknown, but hitherto the baryta has been perishable and has required renewal every twenty-four hours at great expense. They make it virtually indestructible and unchangeable. In this way they claim to have effected an absolute revolution in chemistry, for with a lung for the machine and the atmospheric air for the material they can make just as much oxygen as they like, and the uses of this fluid, present and prospective, are almost innumerable and incalculable.

The doctors would be very glad to have it for purposes of inhalation, only as it has been hitherto made from chlorine it contains a trace of that poison and is therefore a perilous thing to play with. We are now to have, according to the inventors, oxygen not only for the sick chamber, but for the purification of ordinary dwelling houses, and especially of theatres and public halls. It is simply to be turned on into a vitiated atmosphere like a stream of fresh air. Then the oxygen is forced into water to make a new table beverage of the most refreshing and invigorating kind, aerated without the slow poison of carbonic acid. It is to burn with gas or lamp light, and make a flame which is to rival electricity in brightness and brilliancy, and altogether surpass it in cheapness, besides being the one light in the world which shows all colors at their absolute daylight value. In metallurgy it is to produce nothing short of a revolution, as it will feed a fire up to the highest temperature known. In another of its uses, dissolved in water, it is to effect much the same revolution in the bleaching trade. The nitrogen, which was at first looked upon as a waste product incidental to the manufacture of oxygen, is now, by a process due to the ingenuity of the same inventors, to be turned into ammoniacal salts for manure. Most of the uses of these products were formerly known, but this invention, if we are to believe what is claimed for it, tends to make them universal by an almost fabulous reduction in the cost of production. The chemical text books, according to Messrs. Brin, are at fault as to the possibilities of baryta. They all teach that it is destructible; and the Brins maintain that as they know how to treat it, it is indestructible. That is the essence of their invention, and according to them the failure to discover the secret accounts for the fact that so many men of science, beginning with Priestly and Lavoisier, have vainly tried to extract oxygen from atmospheric air. Their efforts have been persistent in proportion to the magnitude of the reward in view. Oxygen in large quantities means a revolution in half the processes of chemical industries.

BOOTS AND SHOES.

In 1836 the State of Massachusetts made, in round numbers, 16,000,000 pairs of boots and shoes; in 1844, 20,000,000; in 1854, 45,000,000; 1864, 31,000,000; in 1874, 59,000,000; in 1880, 78,000,000, and in 1884 (estimated), over 100,000,000! If this is not progress it would be difficult to say in what progress consists. The value of this vast product is estimated at \$120,000,000; and good authority even places it at the superlative amount of \$150,000,000. Such is the pleasant little sum gathered in by the boot and shoe manufacturers and merchants of Massachusetts every year. In the great production Lynn ranks first, with an annual business of nearly \$30,000,000. Haverhill stands second, with more than \$10,000,000. Brockton occupies the third place with \$7,000,000. Number four on the list is Marlboro, which does a business of \$5,000,000. Worcester comes next with over \$4,000,000; then Weymouth; then natick, while Boston stands eighth in the matter of production. New England furnishes more than two-thirds of the total product of the country, Massachusetts the bulk of the New England product, and Essex county the lion's share of the State's business. Lynn is still king in spite of all the changes that have occurred in the trade in the last half century.—*Boston Globe*.

Cut glass is said to have been invented about the year 1609 by Casper Lehman, an iron and steel cutter of Austria. But it was at Nuremberg, near the beginning of the eighteenth century, that glass cutting began to show really fair claims to be reckoned as an art.

FITTINGS FOR CHEMICAL LABORATORY.

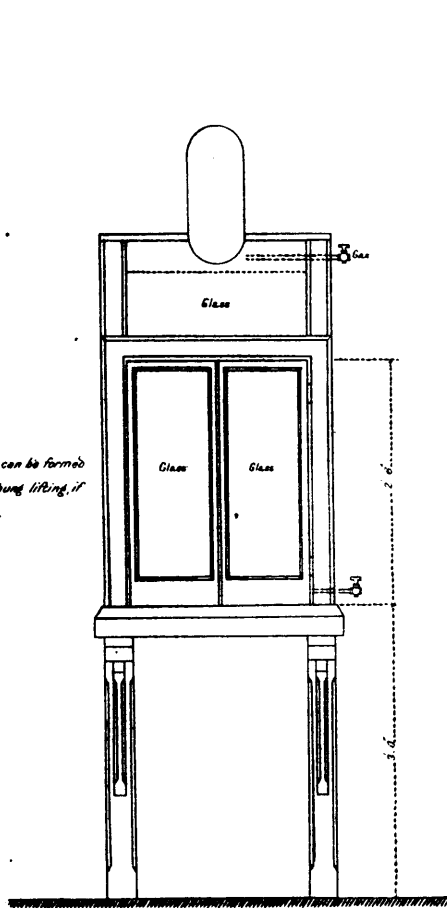

The front can be formed of a sash hung lifting, if preferred.

ELEVATION.

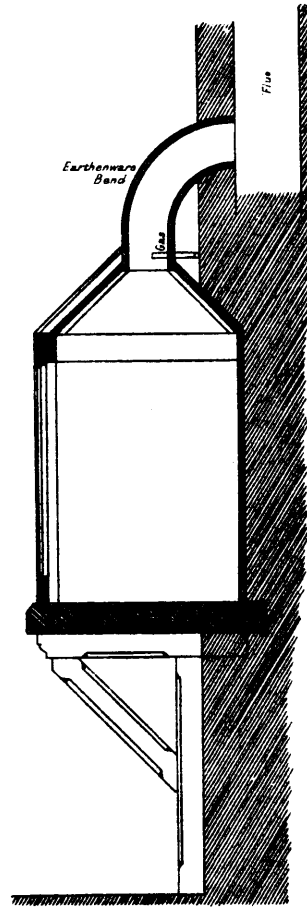

Gas jet formed of a piece of Copper tube plugged at the end and one or two small holes drilled in it.

The Niche may be set deeper in the wall if preferred, but the flue should not come straight out of it, or dirt, moisture &c may fall into it.

SECTION.

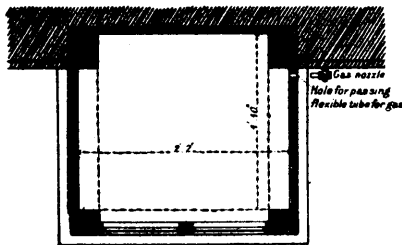

PLAN.

The Bottom may be supported on Brick piers (instead of the brackets shown) and may be of York stone, slate or wood covered with lead

Sides of slate, wood, or Brick on edge rendered with Portland Cement. Back rendered with O^o

SCALE OF FEET.



FITTINGS FOR CHEMICAL LABORATORY.

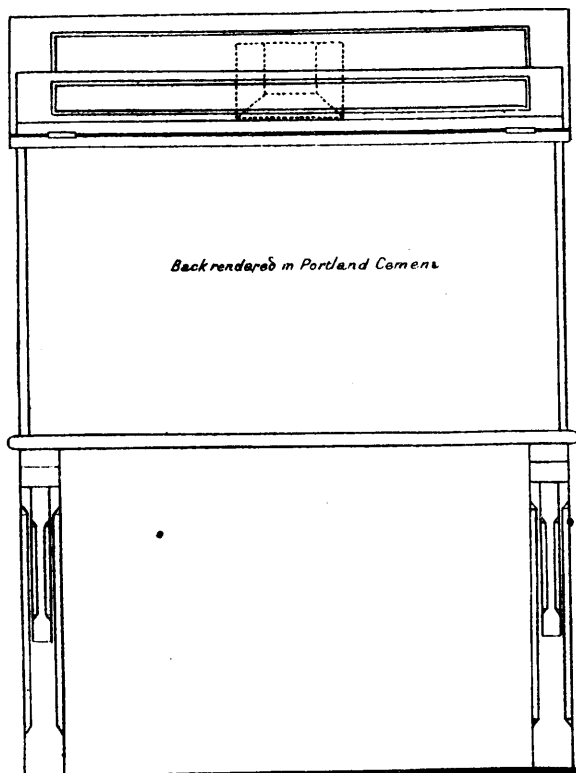

Back rendered in Portland Cement

FRONT ELEVATION.

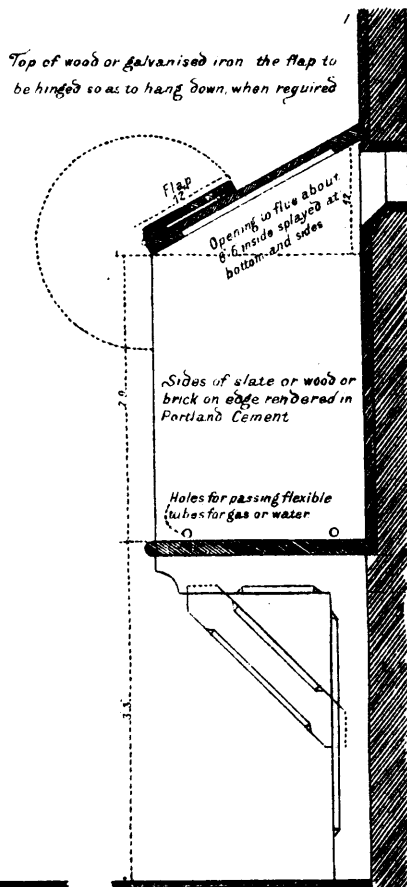

Top of wood or galvanised iron the flap to be hinged so as to hang down, when required

Flap
Opening to flue about 6 in. inside played at bottom and sides

Sides of slate or wood or brick on edge rendered in Portland Cement

Holes for passing flexible tubes for gas or water

SECTION.

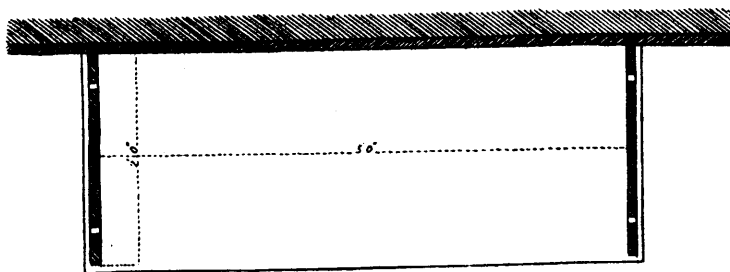

PLAN.

Bottom of slate or York stone or of wood covered with lead The bottom may be supported on brick piers instead of the wood brackets shown.

SCALE OF FEET.



SPEED ON THE OCEAN.

Quick passages across the ocean, such as those recently made by the Etruria, have little to commend them unless they are made in clear weather. Running at high speed in thick or foggy weather is both perilous and unlawful. The International Code of Rules to be observed at sea says distinctly that steamers must run at a "moderate" speed in thick or foggy weather, else they invite danger, not only to themselves, but also to the vessels which may be in their path. When it is remembered that one of these great ships while at full speed will run several miles before she can be brought to a full stop or turned a few degrees to the port or starboard, the absolute necessity for slow running in thick weather is obvious. None suffers so much from these fast trips as the brave fellows who man the great fleet which supplies the whole country with fish. The vessels of this fleet are always to be found lying at anchor or hove-to in the tempestuous seas which continually run across Georges and the Grand Banks.

It is dangerous work lying on these exposed banks at the best times, for the holding-ground, being shifting sands, is bad, the seas high, and especially in the winter season the winds are fierce. But add to these dangers the continual passing to and fro of a fleet of fast-going ships bent on making time, and the chances of disaster are greatly increased. Rarely a season passes that one or more of these fishing vessels, carrying from 15 to 20 men, are not cut down by the iron prows of the transatlantic liners, and a score of families in the Gloucester hills put in mourning.

The heartlessness exhibited at times by the masters of some of these ocean "greyhounds" would be incredible, were it not corroborated as well as it is. One of these ponderous iron ships can cut down a fishing schooner of fifty tons without awakening its sleeping passengers. A slight shock passes through the ship, and all is over. If the gale is blowing, the shouts of the fishermen, struggling in the water, will not be heard below the main deck, and even then only for an instant at the great ship rushes by. Sometimes, so the fishermen say, the commander will stop his ship, and sometimes he will not. Under the usual conditions of weather obtaining on the Banks, it makes little difference whether he does or not. For one of these ships when at full speed will, as said before, run several miles ere she can be brought to a full stop, and before the boats can be launched and sent back it is usually too late; the men in the water having gone down, or been lost to sight in the rolling seas.

Article 18th of the International Code says: "Every steamer when approaching another ship so as to involve risk of collision shall slacken her speed, or stop and reverse if necessary." In these and all other rules to be observed at sea, there is a clause which warns masters of steamers to run slowly, or even stop and blow their whistles, when in thick weather and in a vicinity where usually many vessels are to be found. Hence when the masters of the so called ocean greyhounds run at full speed over the Banks in thick weather, they willfully disobey the law, and wantonly imperil the lives of the fishermen.

There is another side to this, and one that directly concerns the safety of the passengers themselves. The danger of encountering icebergs in the spring and summer upon the ocean highways is always more or less imminent, and this danger increases as the speed of the ship. The thermometer furnishes a fair warning to a trained eye of the vicinity of icebergs when they are to windward of the ship, that is, when the wind is blowing from the ice toward the ship; but when they are dead to leeward, the thermometer has been shown to furnish little or no warning whatever, and to be little better than useless.

It is but fair to say for the Cunard Company, the owner of the Etruria, that for a long time it held itself aloof, and maintained the reliable and conservative course of making safe rather than quick passages; reducing the dangers of the Banks to a minimum by adopting the longer but far safer course to south of this domain of fogs, icebergs, and fishermen. But the demand for quick passages grew apace; the swift-footed ships of rival lines were eagerly sought after by the general public, and quarters in these for the passage commanded high figures. This brought on an attack of the quick-passage fever of the most virulent type; the old and safer Cunard Company exchanged the longer but safe passage for the shorter one over the Banks, bought the Oregon, built the Aurlia, Umbria, and Etruria, and is now apparently outstripping its rivals in the very course which heretofore it so strenuously condemned.—*Sc. Am.*

A MONSTER WATER MEASURE.

There has just been set up at the Corporation dépôt, Audley, a novel kind of meter for measuring the water supplied to the Leeds and Liverpool Canal by the Blackburn Water Committee. The water is conveyed from the old gathering ground to the Audley dépôt in a 12-inch pipe, which empties itself into a small tank at the side of the canal. The measurer, which is self-acting, has been specially designed by the borough and water engineer (Mr. McCallum), and consists of a twin-tumbler or double-tipping tank, which works with a see-saw motion. The tumbler works underneath a weir (which affords the water an outlet from the above-mentioned tank), and it is so shaped and balanced that when one compartment is full the weight of the water causes it to tip over and discharge; the other compartment then immediately begins to fill. This action continues as long as the water is being discharged into canal, both sides filling and emptying alternately. Each compartment holds 100 gallons, and the quantity of water measured is registered by means of a train of wheels and pinions (with dials) worked by an eccentric on shaft of tumbler and a ratchet. As the weight of water at each tip is considerable, two gun-metal hydraulic buffers of novel design are fixed at each side, so arranged so as to let the tumbler fall gently when once it has begun to tip. At the suggestion of the chief engineer to the Canal Company (Mr. Chas. White, C. E.), appliances have been constructed to break the force of the water over weir prior to its entrance into tumbler, and also to ensure uniformity of flow throughout the length of weir. The tumbler is enclosed on three sides by concrete, and the indicator is raised on posts for convenience of reading. The tumbler is made of sheet iron, and has been made and fitted by the Corporation workmen. The hydraulic buffers, brasses etc., have been supplied by Messrs. T. Winter & Co., of this town. The water has been flowing into the canal for several days at the rate of about $1\frac{1}{2}$ to $1\frac{3}{4}$ million gallons per day. The meter records the quantity with great exactness and works very smoothly. It should be pointed out that a most important feature of Mr. McCallum's meter is that it does not depend as to accuracy on elaborate mathematical formulae, but measures the water in as simple a manner as a milkman measures his milk. For the work it is now employed in, or similar, this kind of measure may be considered as very much cheaper and more efficient than any other meter in existence, either positive or inferential; and as it simply depends upon the unerring law of gravitation, it cannot play any of those "tricks" so often experienced in the other forms of meter. Mr. C. White (the canal engineer inspected the meter at the beginning of the week and expressed his approval of it. Any person wishing to see the meter at work may obtain an order on application at the Borough Engineer's Office. *Building and Engineering Times*

PLACING WIRES UNDERGROUND.*

There is no more important question before the electrical community of this city to-day, than the underground line problem. Every branch of business requiring the use of pole lines must shortly be brought face to face with its actual solution. While there may be a difference of opinion as to the authority of the state to compel the abandonment and practical destruction of the overhead plants which actually exist, and which have been constructed in accordance with the requirements of the proper authority, there can be little doubt that the building of a new aerial street line in the future may and probably will be absolutely prohibited in the cities of New York and Brooklyn.

As an instance of the present state of affairs I will call your attention to the dilemma in which the United States Illuminating Co., finds itself to-day. This corporation shares the business of electric lighting for streets with the Brush company in this city. Owing to the enlargement of the Grand Central depot, at 42nd street, and the opening of Depew avenue, it was found necessary to abandon the 44th street station. A new station was equipped at the foot of 29th street, East River, to which the lighting circuits were to be led when the machinery was in readiness. This change required the construction of a new fifty-wire line through 29th street, a distance of 3,600 feet. Upon application to the Commission on Electric Subways, a permit for this purpose was refused. I was informed by president Lynch that they would soon be

* Read by Ralph W. Pope before the National Electric Light Association, New York, August 20th, 1885.

turned out of their old station, that their customers could not be supplied from their other stations, and that nothing remained but for the Commission to provide a method by which they could comply with the law.

I narrate this incident merely to point out to you the conditions existing here to-day. To show also that overhead construction is not entirely prohibited, I will read you the following item from the *Evening Telegram*, of August 19th :

MORE TELEGRAPH POLES.

Gangs of workmen invaded West 28th street this week and erected telegraph poles along both sides of the street, against the protests of the residents, who claim that according to the law recently passed the telegraph companies have no right to erect any new poles, and must put the wires underground.

The members of this association being chiefly interested in arc lighting outside of the territory embraced in the D.ly underground bill, this subject is not in every case one of immediate importance. It is not at all improbable, however that other and smaller cities may enforce similar legislation, therefore it will be wise for you to consider the whole matter very carefully.

As you are, of course aware, the burying of the existing wires in New York is a complicated engineering problem. Not only are there thousands of wires owned by various companies and individuals, but the different systems require different subterranean facilities. Curiously enough the thunderbolts of the press have been hurled with the greatest force against the Western Union Telegraph Co., for its apparent calmness in ignoring the requirements of the law. As a matter of fact this company began placing wires underground about ten years ago, and employed an engineer for the express purpose of preparing plans for a general system, which was to include at least the Western Union, Metropolitan Telephone, Gold and Stock and American District Telegraph companies. I understand this work had to be abandoned mainly because of the destruction of the gutta-percha insulation by the effects of the mains. While in Philadelphia last year I saw a line of arc lamps which I believe were supplied from wires through this conduit. With a little more time at my disposal I should have been glad to have looked into its details more thoroughly.

The conduit, as used in Chicago, appears worthy of attention, as being the most successful system of this class which has thus far stood the test of experience, and may now be seen in actual operation, occupied by telephone, telegraph, and electric light wires. It is made of concrete, formed by mixing asphaltum and silex, and is moulded and at the same time hammered into lengths of three feet, through which are formed at the same time longitudinal ducts, the whole having the general appearance of a tubular boiler. One end is provided with a flange, so that the sections may be securely joined, when they are cemented with the same material applied while hot, and a perfectly tight joint formed. At the corners of the streets man-holes are provided, formed by the same material. These like the conduit itself are gas, sewage and water-proof. The material is said to have stood a government test of 5,500 pounds, crushing strain per cubic inch. It is also a practically perfect insulator; and the ducts are smooth and uniform inside, being about two inches in diameter. Mr. Callander informs me that he has drawn several miles of cable into them without any apparent damage from abrasion. This system was adopted over a year ago for the municipal wires in Chicago, and also by the Underground Conduit Co., of which Professor Elisha Gray is president.

A recent experiment which will perhaps be of interest to you, appears to have fully demonstrated the insulating properties of the concrete, which being cheap may possibly be practically utilized in this novel manner. The test which was but an experiment, consisting in placing naked wires in one of these underground conduits for carrying electric light currents. The plant of 40 lights is still running successfully. While this proves conclusively that such wires may be safely run in the manner indicated, it was not intended to continue the arrangement permanently. The installation of the wires spoken of where they are liable to dampness or other interference at the terminals of the pipe, was very complete, and the insulation rendered very thorough by the following process, which is given for the benefit of those interested: the wire, before drawing in, was thoroughly taped from the union between the naked copper and the outside wire, for a few inches at either conduit terminal into the pipe. A cork, slit to receive the

wire, was then placed upon this latter, and crowded into the end of the conduit about an inch. Then this countersunk space was filled with the compound which completely insulated the wire at the terminals of the tube, and made these air, water and gas tight, at the same time. As some of the members present may have occasion to visit Chicago, I would suggest that it might be worth their while to satisfy themselves of the merits of this conduit, as can of course be done most effectually by examination and enquiry on the spot.

Whatever conduit may be used the individual insulation of wires is essential. The tests which have been made thus far with insulation for arc lamp wires under these conditions are exceedingly meagre. A series of tests are now being made by the Standard Underground Cable Co., of Pittsburg, which will doubtless be of value in this respect.

It is a peculiar trait of human nature that we prefer to profit by our own experience rather than abide by the testimony of others. I would therefore respectfully suggest that such members as can do so, should after careful consideration of the subject undertake the construction of short experimental underground lines with a view not only to preparation for the future, but to ascertain for the benefit of the entire fraternity the best insulating material for subterranean arc wires. In cases where antagonistic legislation is threatened, the very fact that you are laboring in that direction may prevent your being forced to do so, hastily and against your will.

The burying of the wires in New York is a work of great magnitude, and should properly have been begun many years ago in order that we might have thoroughly learned our trade instead of undertaking so vast a job as mere apprentices in underground work.

My brief intercourse with the Commissioners leads me to believe that they fully realize the importance of performing the duty which has been placed upon them, with a proper regard for the continuance of all classes of service without interruption. When the task is finally completed, and the wires working satisfactorily, with bills all paid, and dividends appearing regularly and frequently, we may be happier—I am sure we shall be older.

THE DURABILITY OF DYNAMOS.

The subject of the life of a dynamo for electric lighting purposes, has been frequently brought to our attention by many who are anxious to see the electric light at their mills or works, but have been deterred from incurring the expense of an installation by the absurdly incorrect statements made, and often accepted, relative to the durability of a dynamo. Its life has been variously given at two years and upwards, an estimate so low as to be sufficiently absurd. If a dynamo be cursorily examined, it will be seen that the elements of "wear and tear" are but small. The field-magnets and pole-pieces of solid iron, carefully wound with layers of well insulated wire, present nothing for deterioration. The properly-constructed, well fitted "armature" should last without fear of damage, with the exception of such parts as are liable to friction. In the bearings themselves, if properly lubricated, there can be no wear more than in any ordinary engine bearing, but it is in the "commutator" and the collecting "brushes" that wear must go on. We have here the copper brushes pressing against the copper bars of the armature commutator revolving at various speeds, and it is here, where there is a certain amount of friction, that there must not only be a certain loss of material in the brushes, but also in the commutator bars. This loss is certain and definitely small with a good dynamo and one carefully attended to, but with inferior dynamos and loose attention, when "sparking" occurs the brushes are soon worn down, and the bars getting "scored" sooner require being "turned" to get a smooth surface. The sparking of a dynamo must sooner or later ruin a commutator (but it is a considerable advantage to know that you possess a machine whose commutator can be easily replaced), as every spark means more or less metal destroyed.

In a paper recently read on "Electric Lighting for Steamships," it was mentioned that the dynamos on the "Himalaya" had an exciter of the Siemens type. It had been running constantly for two years, and had not had any repairs done to the commutator, which might be considered very good wear. Although this question is one of great interest as affecting the "maintenance" of an electric light installation it was not again referred to, but in a recent number of our contemporary, the *Electrical Review*, particulars are given by Mr. Earnest

FITTINGS FOR LABORATORY.

PL. 5.

WIND FURNACE.

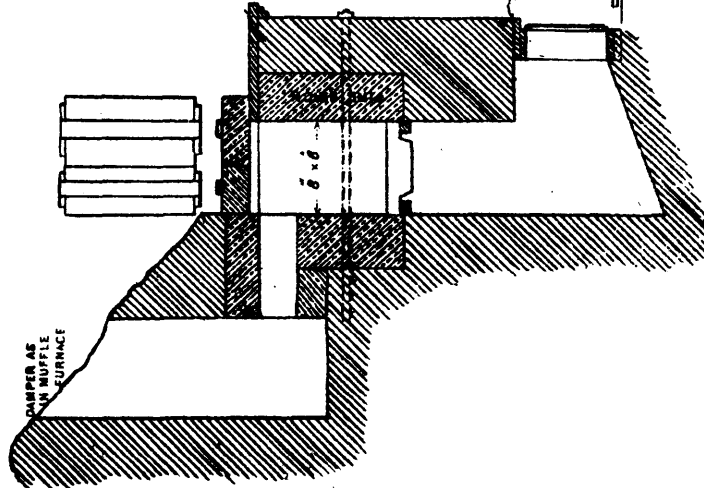

PL. 6.

MUFFLE FURNACE.

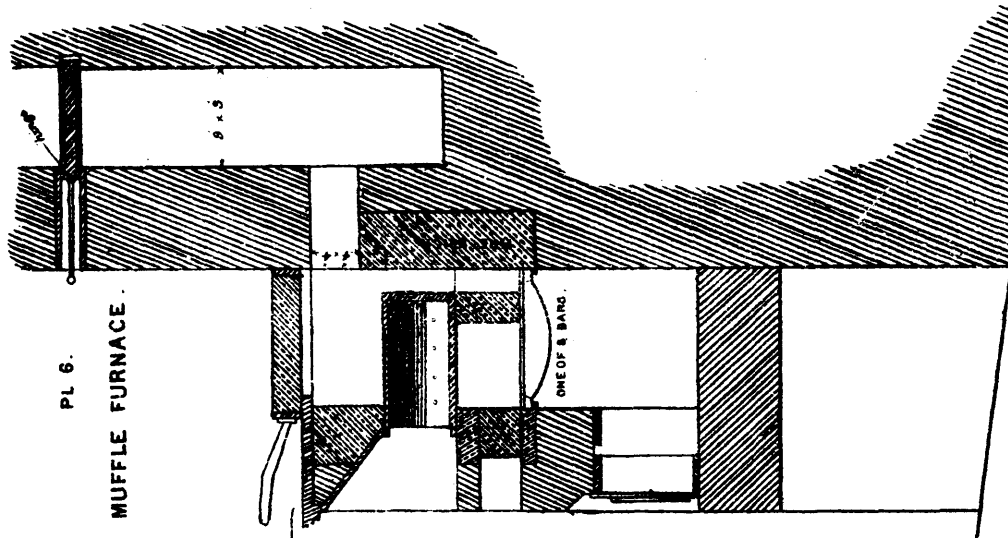

SCALE OF FEET.



THE PARISH NEW THROTTLING ENGINES.

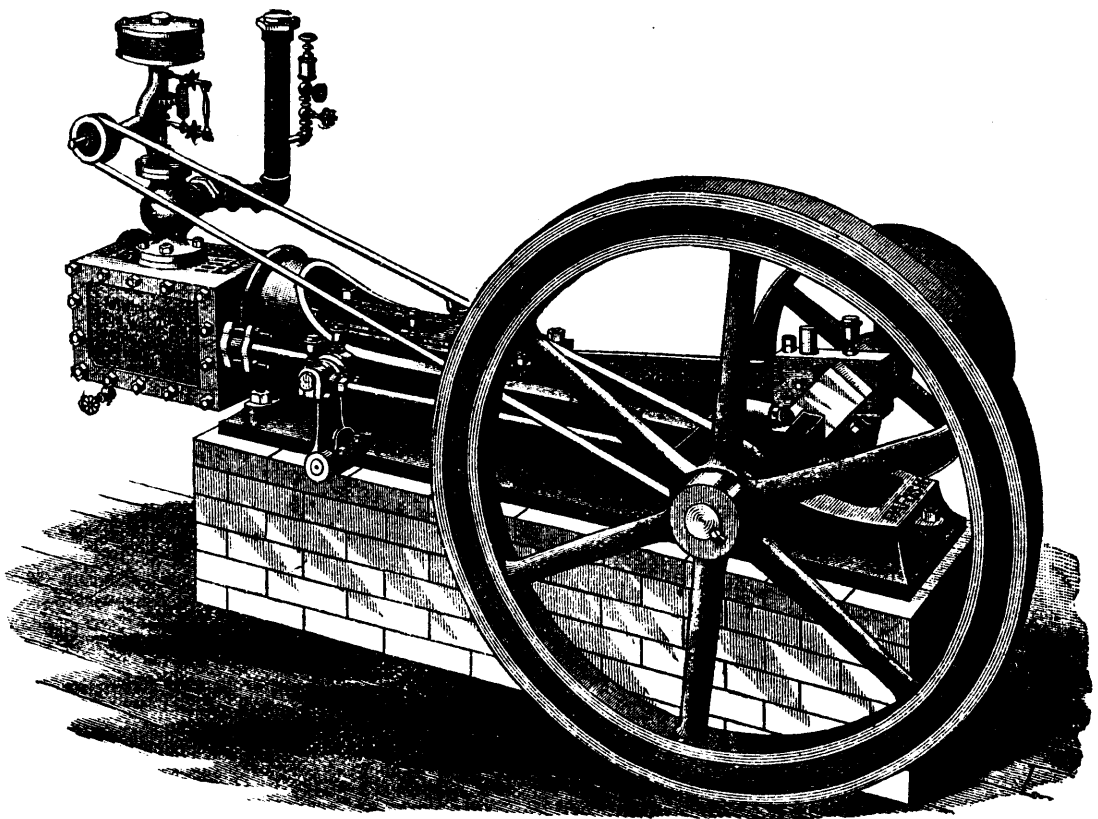
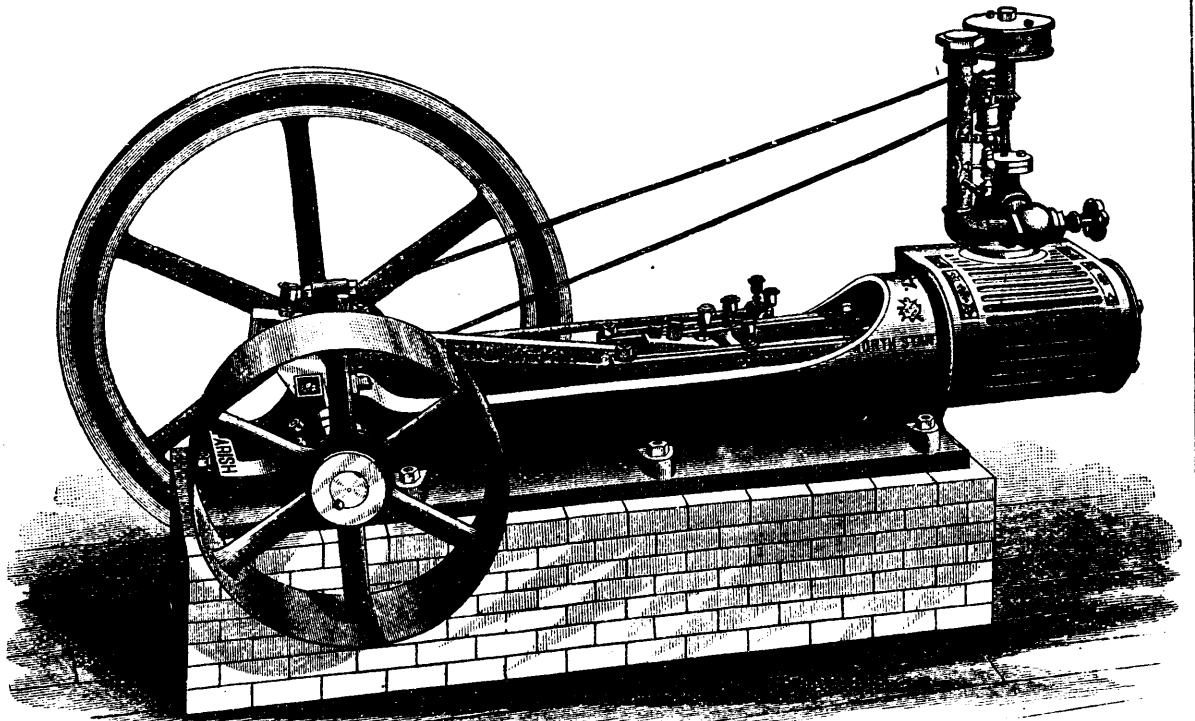

Berry, of the first year's cost of the installation at the Prince's Theatre, London, and he remarks that the Siemens dynamo "is in as good condition as when it was first put down, with the exception of the wear on commutator (which, on being measured after 12 months' wear, was found to be 5-16ths of an inch). The machine has used in that time 5½ pairs of brushes four inches wide." From the number of dynamos we have seen at various times, we should consider that in this case the "depreciation" of the dynamo and the cost of maintenance above the average. It was only a short time before this case met our attention that we carefully examined a dynamo, which was also used for a theatrical installation in order to see what the loss had been on the commutator. It was a 250-light Edison machine, and had been constantly running for nearly 2½ years, and from the feel of the hand over the commutator, it was almost impossible to perceive that there was any wear. Applying a straight-edge, it was possible to perceive that the surface had been reduced to the extent of the thickness of a piece of writing paper. As regards the brushes, these were the same as originally fixed, and would still last for a longer period. In this machine (running at 820 revolutions per minute) sparking was never observed; the same may be said of the other Edison machines of the same type belonging to the same installation.

The wear and tear of this dynamo was practically almost *nil*, and granted that it received in the future the same attention it has had in the past, it would be almost impossible to fix the limit when the occasion would have arrived to replace the commutator with a new one. The average life of a dynamo may, therefore, be considered to be at a high figure, provided that due care be taken of the adjustment of the brushes; and its cost of maintenance as that of an occasional pair of brushes, and the removal of the commutator, the cost of which would have to be spread over a number of years.—*Mechanical World*.

WESTON INCANDESCENT LAMP FITTING.

THE contact obtained with hook-and-eye connections in the original form of socket and lamp brought out by Mr. Edward Weston, Newark, N.J., was somewhat imperfect, particularly in cases where there was much vibration. Large percentages of lamp with the eye terminals were rendered useless by the breaking off of the eyes during handling in the last stage of manufacture in packing and unpacking, in fitting, and in the attempts of the uninitiated to twist the lamp whilst in their sockets or in their removal for the purpose of cleaning and in short-circuiting by the wire being brought into contact by twisting. These defects led Mr. Weston to design a new holder, in which he retained the switch action and, in some measure, the external form of the old one. The change necessitated a modification in the neck or base of the lamp, which, however fitted well with the desire to separate the conductors to a distance sufficient to prevent the liability of the current to jump across, when the increased resistance of the later lamp called for increased electromotive force. The base or neck of the lamp is drawn out and firmly cemented into a thin metallic shell, leaving space for the reception of a block of insulating material, teeshaped in section, carrying contact plates or washers, to which the terminals of these lamp conductors are soldered. These contact plates are fastened respectively to the underside of the main portion of the tee and to the bottom of its leg. The lamp-holder consists of a base or flange of metal tapped with a standard thread for its attachment to gas and electric light fittings. This supports a block of insulating material fitted with contact springs and a switch action for opening and closing the lamp circuit. The whole is enclosed by a metal shell attached to the base. Fig. 1, is an elevation of the lamp socket and lamp actual size. In wiring and fitting fixture, the base is screwed to the bracket or to the branch of an electrolier and the wires brought through two holes provided in the base, as shown in Fig. 2; that is when the wires are run outside the fixture, which is not provided with means for concealing them, and where they are still retained for gas purposes, which prevents the wire from being run through the tubes with electric light fixtures, the wires are brought through the centre of the base from the pipe to which the holder is attached. The insulating block with switch and contact springs is then secured to the base, and the wires fastened by screws to plates which are connected with the positive and negative contact springs, one directly and the other through the switch or cut-out. The metal shell is finally slipped over all and secured to the base. A groove is spun in

the upper end of the shell slotted at opposite ends of its diameter to receive two corresponding pins or projections punched up in the base shell of the lamp, and at right angles to the slots there are two indents in the grooves into which the contact springs press the pins in the lamp base, being inserted into the holder and given a quarter turn; by this means the lamp is locked in position not so firmly as to prevent its turning readily to right or left for the unlocking and removal of the lamp, but sufficiently so to prevent its jarring out by vibration, as happens with lamps which are screwed at the base or simply held by friction. A new lamp may readily be inserted even in a dark room, no matter if the circuit be closed or open through the switch. In this holder a good surface contact is obtained, and every time the lamp is turned either for insertion or removal the contacts are scraped clear of dirt or oxide, and at the same time the breakage of lamps by clumsy attempts to twist them in their sockets is prevented.

The switch action is similar to that in the earlier form of holder, and to the gangswitches modelled from it. The switch action itself, which is shown in Fig. 3 removed from the holder consists of a metallic frame or bracket to which is hinged by one end, a lever having contact surfaces at the other, and a small friction roller intermediate between the two. An oval cam indented at the extremities of its longer axis is engaged by the roller on the lever, and retained in that position by the pressure of a spring which acts between the bracket and the lever, and contact is made between the contact and the two contact springs, which are inserted in one leg of the branch to the lamp. The cam is mounted on a spindle having its bearings in the bracket, and a portion of one of the bosses of the cam is cut away or slotted, the spindle has fitted to it a projection or pin, whose function is to bear against one end of the slot and carry the cam around with it when it is turned by the spindle. As soon as the indent of the cam is disengaged, the lever flies off with a trigger-like action, the cam offering no resistance, being free to turn upon the spindle to the extent of the slot. No matter in which direction the switch is turned the action is the same, and the circuit is broken with great rapidity. The quick action of the switch so reduces the amount of spark that the durability of the contact surface is much greater than that of any other form of switch. The circuit is closed by turning the spindle till the cam acting on the lever brings it into the position illustrated, and the scraping action of the lever over the spring keeps the contact surface clean and bright.

The electrical joint for swinging brackets is without the usual sliding contacts which entail complicated and expensive details to insure good insulation, and to take up the wear of the sliding surfaces which produces defective contacts and instability of the bracket. Brackets with one, two, or more joints may be wired throughout by continuous conductors. In appearance the joint resembles the ordinary gas joint, and lends itself readily to ornamentation. The interior is fitted with a spool of insulating material around which flexible conductors are coiled in a double spiral (see Fig. 4) leaving sufficient space between the core of the spool and the inner walls of the joint for the expansion and the contraction for the diameter of the coils when twisted by the turning of the joint to right or left. The spool is made in two parts, one with a core and flange which is fixed by a set screw to the lower or stationary part of the joint, and an upper flange fitted loosely over the end of the core and attached to the upper or swinging part of the joint by a screw, in order that it may turn with it. The upper moving part of the joint is held in position vertically by a set screw projecting into a groove cut in the lower part so that there is freedom to move only horizontally. The joints are screwed with standard gas thread and can be used by any intelligent mechanic in the construction of fittings as readily as the ordinary gas joint. The wiring of brackets fitted with these joints can readily and quickly be accomplished; flexible conductors are threaded through the fixture, the spool removed from the joint through the opening in the upper part of the joint, the wires brought through holes in the lower flange coiled around the core of the spool and through holes in the loose flange, the coil is then returned to the cavity in the joint and the conductors passed through the fixture to the next joint, if there be one, or to the lamp socket.

Wall Plate and Flange.—The wall plate or block (Fig. 5) is of insulating material and carries two contact springs to which the branch wires are attached. The flange is of metal, iron or brass; (Fig. 5a a back view) the front view being shown on the wall plate in Figs. b and c, which are respectively a face

view and section. The flange is tapped for gas pipe and has fitted to it, but insulated from it, contact screws to which the bracket conductors are attached, the one directly and the other being interrupted by safety strip contact springs. The contact screws are so arranged as to come against the contact springs in the wall plate when the flange is screwed against it, and maintain the connection from the bracket with the branch wires. A slot is cut in the flange through which a safety slip cemented to a wooden block is inserted, and held in position by a hinged cover, to allow a ready replacement of the strip when it fuses. The bracket is readily removed from the wall plate without deranging the branch wires, should it be necessary to take it apart for readjustment of the conductors or for repair.

For table lamps, hand lamps, and generally for electric connections by means of flexible conductors a special fitting has been designed by Mr. Weston. It is a combination of the holder socket without the switch and the wall plate, of which descriptions have already been given. Figs. 6 and 7 illustrate a fitting which has been much used and sufficiently resembles the one now manufactured for the purpose of its description.

The modifications have been made principally for economic reasons, and with a view to greater uniformity throughout the system. Provision is made, as in the bracket wall plate, for the insertion of a fusible metal. The plug is slightly altered in dimensions to be identical with the base of the incandescent lamp in order that it may be fitted into the incandescent holders, as well as into the wall plate, and as the wall plate is made to correspond a lamp may be inserted into it instead of the plug. This modification suits the plug wall plate for use as a cheap form of lamp support, and is particularly useful for low-ceilinged apartments, cellars, cupboards, shop fronts, and for theatrical and decorative work. A flexible double conductor is attached to the plug by one pair of terminals, and to the other may be attached a hand or table lamp, motor, or other electric apparatus which it may be desired to have in a movable form. A considerable number of these fittings are provided with the Weston installations, particularly in factories, warehouses, etc., and are used for hand lamps, which are suspended in a desirable position for general illumination when not otherwise required. In cellars or warehouses, or where a large amount of illumination is not required, but where one or two movable lights are desirable, a series of plates are fitted along the wall within easy reach, and one or two lamps with plugs and cords are supplied which can be carried from one place to another for use.

Weston's gang and multiple series switches have an action precisely similar to that of the holder switch of which details have already been shown. The lever is modified to make duplicate contacts, in order that two or more short breaks may be made in a circuit instead of one long one. In order to economise space and adapt the switch to a circular case or box (Figs. 8, 9, and 10) the switch is shown with a closed circuit. The contact springs are doubled and the pins in the extremities of the bell-crank lever enter between the two. This construction is adopted to obtain a large amount of contact surface and sufficient flexibility to the contact springs. At the same time that the necessary conducting capacity is secured the springs are split, as are all spring contacts in the Weston system when their construction permits, and the scraping action is also provided for. The conductors to which the switch is attached are cut and the ends brought up through the base and connected to the posts carrying the contact springs, the bell-crank lever making the circuit by bridging across the spring. The multiple series switch differs only slightly in its details (Fig. 11) from the gang switch, and in its external appearance is the same, but the arrangement of its connection are changed; the gang switch is designed to open and close a single circuit, whilst the multiple series switch operates two, closing one when the other is opened for the purposes detailed in the description of the multiple series system.

Fusible strip blocks, branch blocks for cased or moulded leads and branches, and the whole of the fittings which come under this heading, are designed by Mr. Weston with a view to uniformity and neatness of wiring. Each size corresponds with a standard section of moulding or casing, just as do the pipe fittings used by gas and steam fitters; the safety strip blocks are made both single and double, that is for the insertion of a strip in one or both leads of the multiple arc system of wiring, and they are made of widths to suit various breadths of casings and with the contacts arranged at the same distance apart, if double, as are the wires, and in any case to come im-

mediately over the grooves containing the wires. The illustrations (Figs. 12 and 13) represent a single pole strip block closed and open, and fitted to the moulding in which the conductors are protected: in all these fittings the strips are tacked or cemented to wooden blocks having holes corresponding to dowel pins in the hinged cover of the block, so that the mere act of setting them on the cover puts them in their correct position with relation to the contacts in the body of the block. The contacts are plates of metal supported on spiral springs, which keep them in contact with the ends of the strips when the cover is fastened down, which is done by means of a screw or button; for heavy currents clamp contacts are used, and the strips are unmounted and have their ends heavily plated with copper both for the purpose of having a good contact and for preventing the compression of the strip.

For branches or loops from the main leads, branch boxes are provided in order that the safety metals may be inserted immediately at the point of branching off. In the smaller sizes of branch boxes (Figs. 14 and 15), the contacts for the metals are mounted on spiral springs as in the strip blocks. Fig. 14 shows a double branch box fitted to casings, portions of which are shown cut away to expose the wires. The main leads are shown as composed of a number of small wires, but the boxes are equally applicable to installations where the leads are each one large wire. The undersides of the blocks are provided with screw clamps, by means of which connection is made with the mains. On looking at the figure, it will be observed that two of the safety strip contacts, diagonally placed, are mounted or cemented to larger squares than the other set, and each with an extra screw; and further, that these plates are immediately over the main wires. The blocks are connected by the clamp with the main leads, and the contact is made good by the extra screws referred to. At the other corners of the block, the strip contacts make no direct connection with the leads. In connecting up the branches one wire of each branch is connected to the contacts which are in direct connection with the leads and the other two with the isolated contacts.

Thus each lead has one leg of a branch connected directly with it and the other, only when the cover is closed, and a safety metal bridges the break in the branch between the two contacts.

This block may be used as a double strip block, when it is desired to insert a strip in each pole of a branch, as will be readily understood.

Fig. 15 is a view of a single branch box, with the cover thrown back to expose the interior and with portions of the casings cut away to show the mains and the branch wires. The larger branch blocks having greater internal space are fitted with a spring contact similar to that used in the wall blocks or plates. Fig. 16 shows an open view of a double branch with mouldings cut away as in the other figures. These blocks differ from the smaller blocks merely in the form of contact springs and are connected with the leads in the same manner.

The whole of the strip blocks and branch blocks used for the Weston installations, are attached by screws to the lower grooved portion of the casings, and the casing covers are fitted to a nut directly against the block as shown in the figures, concealing all connections and finishing the work in a neat and symmetrical manner. There can be no liability of shocks to the person, as no part of the body can be brought in contact with the wires or connections when once fitted. Short circuits or grounds from the accidental contact of conducting substances being accidentally placed across the leads or branches cannot occur, and if short circuit occur from other causes, the fusible metals take care of the circuits. Each of Mr. Weston's fittings have been designed as a part of a system, so that they may all be connected together with ease and rapidity. Their dimensions are regulated by standard gauges, and they may be ordered by number from the lists and catalogues just as the gas or steam fitter orders his pipes, tees, elbows, and other fittings.

Corresponding with the pipes of the gas system are the mouldings or casings in the incandescent system, with the tees, elbows, unions, and flanges; there are the double and single branch blocks, and the wall plates. The incandescent holders and switches take the place of the burner sockets and the cocks or taps of the gas system. In both systems there are swinging joints, and the plug and flexible cord of the incandescent plant corresponding with the hose coupling and hose of the gas or water system. In all these fittings the parts which make contact are prevented from oxidation by heavy nickel plating, and the scraping action of the contacts further insures perfectly clean surfaces. There is no limit to the adaptability of

THE WESTON SYSTEM OF INCANDESCENT LAMP FITTINGS.

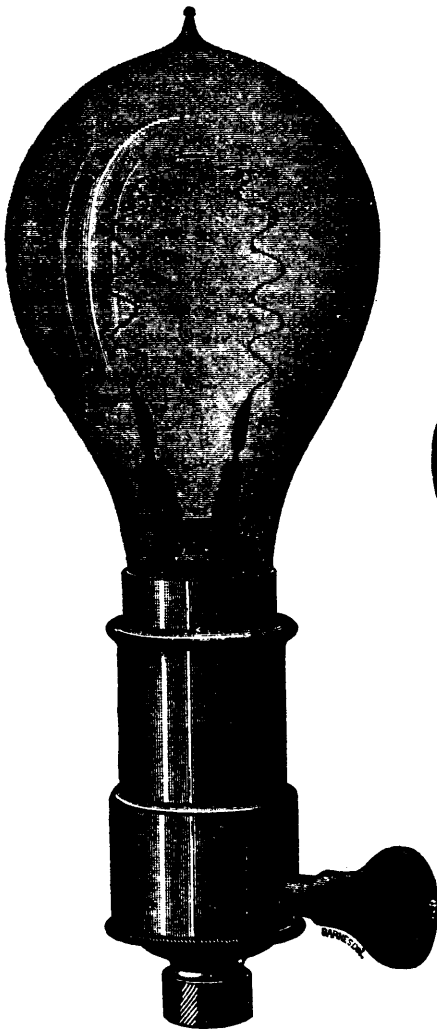

FIG. 1.

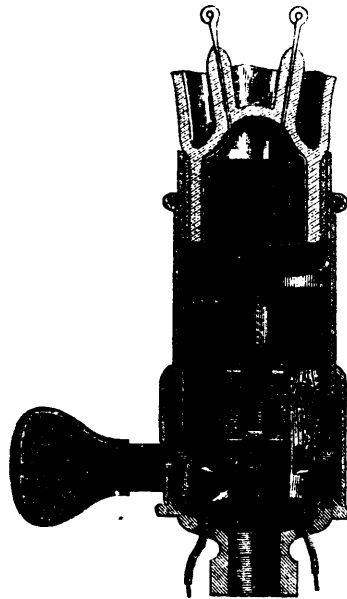

FIG. 2.

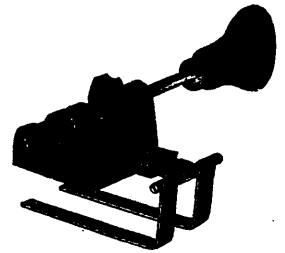

FIG. 3.

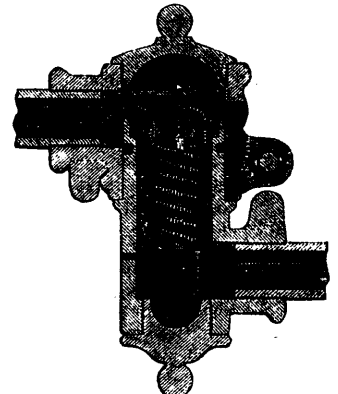

FIG. 4.

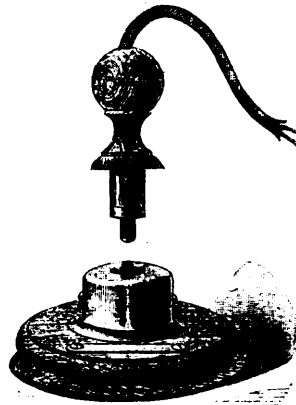

FIG. 6.

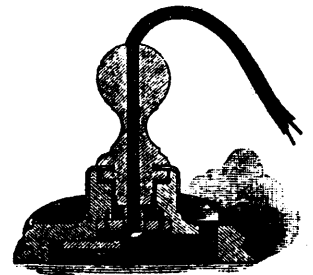

FIG. 7.

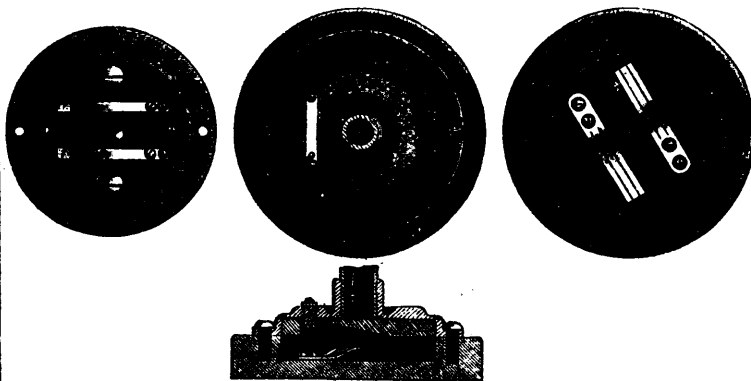

FIG. 5.

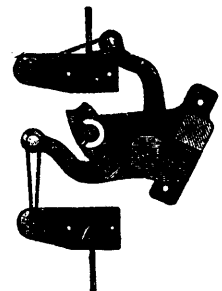

FIG. 8.

THE WESTON SYSTEM OF INCANDESCENT LAMP FITTINGS.

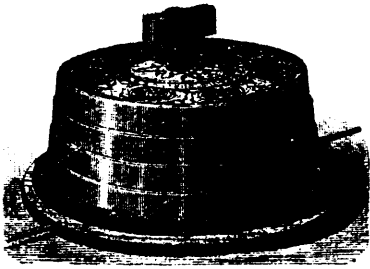

FIG. 9.

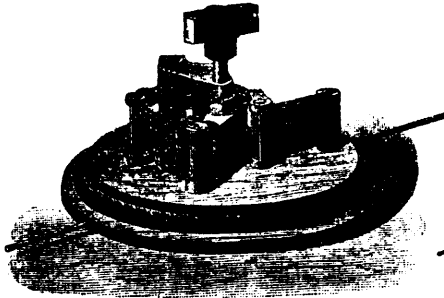

FIG. 10.



FIG. 11.

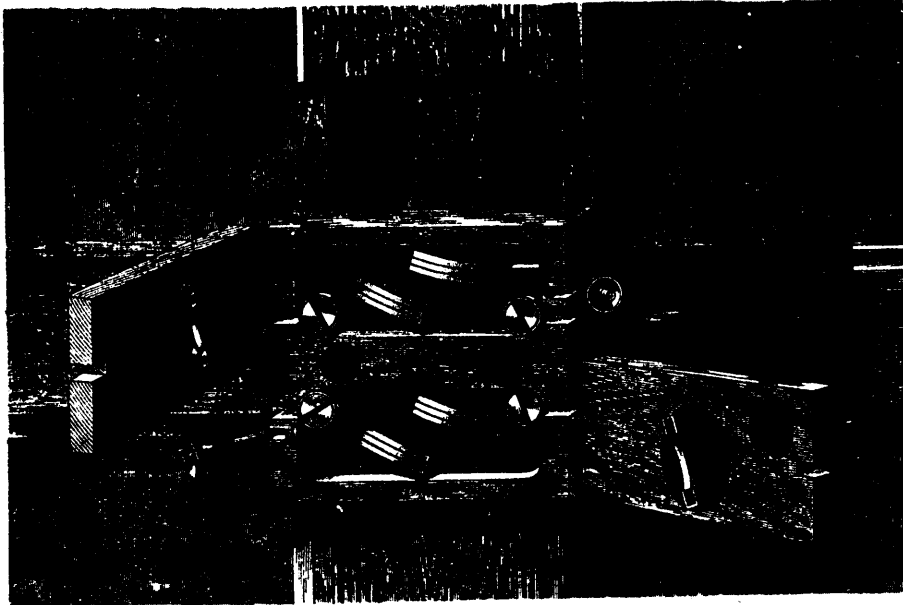

FIG. 16.

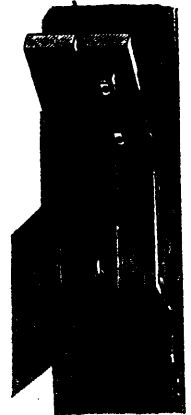

FIG. 12.

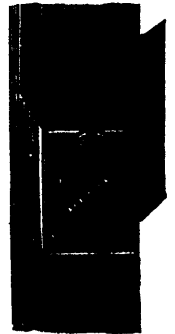

FIG. 13.



FIG. 14.

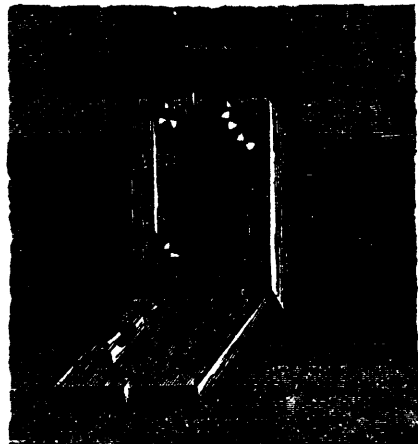

FIG. 15.

these fixtures to ornamentation, so that installations are made in decorating buildings without interfering with the general effect.—*Eng.*

THE SMITH VENTILATOR FAN.

We present herewith a number of illustrations, or diagrams representing the various uses etc., to which a ventilator fan can be adapted.

The particular fan we describe is known as the Smith Ventilator Fan, which is coming largely into use, and is gaining rapidly in reputation. In its construction there are some novel features which in connection with the claims made in respect to its performance, entitle it to especial attention from users of this class of machinery.

The weak point of all ventilators is encountered when it is attempted to move air *against any pressure*, however, slight. In such cases a portion of the air will slip back through the centre of the wheel, the area and amount of slip increasing with the increase of pressure. This result is expected when we consider that the thrust or propelling power of a screw fan (for such all these devices are) is greatest when (1st) the angle of the blade is the least, (2d) the velocity and area are the greatest. That is to say, the efficiency of such a wheel is greatest at its circumference, and reduces to nothing at the center. If there were no back pressure, nearly the whole surface of the blade would act, but as pressure must always exist in some degree, there is always a portion of the wheel near the centre which cannot create a velocity equal to the resisting pressure, and as a consequence the air flows back through that portion of the wheel. As a consequence the wheel falls short of its capacity. The obvious remedy is to stop off the centre of the wheel by a plate, which is precisely the construction of the Smith wheel. The area stopped off is so proportioned that the wheel will blow without back-lash against a four ounce pressure. It is claimed that this or anything near it is not possible with any other wheel. Constructively, the centre plate adds to the strength of the wheel.

This Ventilator Fan can be used for delivering fresh air in, or removing foul air, gas, steam, smoke, etc., from factories, basements, holds of vessels, hospitals, theaters, hotels, public buildings, prison wards, mines, paper mills, glue works, chemical works, engine rooms, etc. For creating a draft or current of air in malt kilns, wool and tobacco dryers, or for use in refrigerators, cold storage, cooling workmen at smith fires, furnace room, reducing the temperature in the holds of vessels, removing dust from flouring mills, elevators, and holds of vessels, etc., and the manufacturers claim for it that it is of the best design and finish, and strongest throughout. It can be placed and operated in any position—horizontal, perpendicular or otherwise. It can be piped to conduct the air to any desired place, by simply slipping the air conducting pipe over the outside of the shell or case of the fan. It will draw air from or push air to any desired place through same pipes by simply reversing the belt, delivery being as positive either way. When piped to "dry kilns" or any place where considerable pressure, friction or resistance to the passage of the air occurs, it will push forward the air against a back pressure of four ounces to the square inch, without any loss by back-lash through center of wheel. The wheel is enclosed by a case which acts in combination with the wheel; it also prevents accidents which often occur with wheels not protected by casing. It is comparatively noiseless in operation.

Figure 1 gives a general perspective view of a 24-inch fan, which, by the way, has a capacity of 10,000 cubic feet of air per minute.

Figure 2 shows the use of the fan in a malt drying house.

Figures 3 and 4 give sectional views of the application of the fan to drying-kilns, etc.

Figures 5 and 6 need no explanation, the adaptation of the fan is evident.

Figure 7 shows the fan adapted to mine ventilation, and fans up to a capacity of 1,000,000 cubic feet of air per minute can be made.

Figure 8 is another use to which the ventilator may be applied with success either as forced draught, or to supply the necessary amount of air to boilers and furnaces.—*Am. Eng.*

TUNING FORKS and grindstones are now made of glass. Rails and sleepers are manufactured from the same transparent material. The new process is a simple one, and produces hard glass castings at a low cost.

A SUNKEN CONTINENT IN THE PACIFIC.

The fact is quite generally conceded among scientists that the probabilities are strongly in favour of the supposition that there formerly existed a large island, of continental dimensions, between the West Indies and the western coast of Africa. This continent is supposed to be the "Atlantis" of the ancients, whose recent discoveries point to the further probability that there also once existed a similar continental area of land in the Pacific ocean, between the west coast of South America and the present Australian continent; as it is sometimes called.

At a recent meeting of the Academy of Sciences of San Francisco, Capt. Churchill read a very interesting paper in relation to this matter. His paper referred especially to the gigantic sculptured figures still to be seen upon Easter island, and evidently the work of a different race than that which now inhabits the island, and one much more numerous, since the works referred to are on too large a scale to have been constructed except by many hands. He argued that a vast continent once existed where there is now nothing but a waste of ocean, dotted with countless isles and inlets of varying size and character, the majority showing in their formation the traces of that former volcanic action, which either upheaved them from the depths of the sea or shattered and sunk the continent of which they are now the only vestige. Easter island, it is believed, was once the home of a population numbering many thousands, of whom scarcely any now remain. Besides dwelling upon the sculptured figures to be found there, Capt. Churchill laid much stress upon the hieroglyphic tablets of wood discovered upon Easter island, and which are the only instance of a written language in Oceania. He thought sufficient attention had not been given them.

From other sources we learn that a German Government vessel recently visited that island and made a large collection of prehistoric remains, and made copious notes of other matters of scientific interest. The German Government, it is understood, are making preparations to send another expedition to Easter island with a corps of scientists and engineers to sketch the island, surveying the ground, and to make plans and sections of the prehistoric buildings and ruins.

Our own Government has also taken steps to secure some of these valuable remains representing the prehistoric and known races of this hemisphere. Instructions have already been sent to Admiral Upshur, in command of the South Pacific squadron, to send one of his vessels on a cruise in the direction of Easter island and to make such explorations, collections and reports as he may think important in the interests of the Government. The Government of France is also turning its attention to this island with a view to the establishment of a protectorate.

It is reported in the accounts given by the German vessel that the island, which is small, is strewn with large stone images and sculptured tablets. The inhabitants of the island know nothing about the remains, and even tradition gives no account of a people living there when their ancestors arrived.

HOW MACHINERY IS RUINED.

We have again beheld the results of "smart Aleck" engineers, those \$10 per week men, who are expected to attend to their employer's horses, sweep up the shop, and what spare time they have attend to their boilers and engines. During the past week we were in one of the southern cities. The elegant hotel where we picked our teeth was lighted by electricity. One day the "thing" (I cannot bring myself down so low as to disgrace my loved profession by calling him an engineer) had keyed up his engine without letting the electrician know of it. About an hour after it started, somehow it got tired and stopped. Imagine the effect—house in mourning. Had melted linings of brasses; electrician mad; saw us and asked assistance; given; brasses changed in a few moments; engine started; enjoyed an evening with electrician; were chums eighteen years ago on a western railroad; expressed our mind plainly regarding "thing"; no good; employer believes that if a man can throw coal he is as good as can be. We have seen engineers around hotels who were porters and wood sawyers, and the only wonder is that we don't hear of more "Galveston" accidents. For "Contented's" benefit, allow us to inform him that we are not tramping in search of employment. We choose that cognomen because our work calls us all over the country, and because we are so situated as to be directly opposite the tramp. From that hypothesis we argue that he sails under the "contented" flag because he is "uncontented."—*Boston Journal of Commerce.* TRAMP.

CHEESE POISON.

The following is an abstract of a paper by Prof. V. C. Vaughan, M. D., Ph. D., read at the meeting of the Michigan State Board of Health, July 14, 1885. Dr. Vaughan presented a report of his investigations on poisonous cheese. It is well known that cases of severe illness follow the eating of some cheese. Such instances are of frequent occurrence in the North German countries and in the United States. In England they are less frequently observed; while in France, where much cheese is made and eaten, these cases are said to occur very rarely. A few years ago, the reputation of a large cheese factory in Northern Ohio was destroyed by the great number of cases of alarming illness arising from eating its cheese. Dairy-men know this cheese as "sick" cheese.

KINDS OF CHEESE THAT ARE POISONOUS.

A German author says: "The numerous kinds of soft cheese, prepared in small families, or on small farms, are generally the cause of the symptoms; while it is quite exceptional to hear of symptoms arising from the use of cheese prepared in large quantities." Some two years ago, a family in Alpena, Mich., was poisoned by eating of cottage cheese; but the cheese which poisoned so many in this State last year was made at one of the largest factories in the State, and by a thoroughly experienced cheese maker. The old foul smelling cheese, such as Limburger and Schweitzer, have never been known to be poisonous.

EFFECTS OF THE CHEESE.

The symptoms produced by "sick" cheese, as reported by German and American physicians, agree quite closely and are as follows: Dryness of the mouth and throat with a sense of constriction, nausea, vomiting, diarrhea, headache, sometimes double vision, and marked nervous prostration. In rare instances the sufferer dies from collapse. As a rule recovery occurs in a few hours, or at most after a few days. The symptoms of cheese poisoning and those of sausage, canned meats and fish poisoning are very similar, though death results more frequently from the others mentioned than from cheese poisoning.

APPEARANCE OF THE CHEESE.

The samples of cheese examined had no peculiarities of appearance, odor or taste, by which it could be distinguished from good cheese. It is true that if two pieces of cheese—one poisonous and the other wholesome—were offered to a dog or cat, the animal would select the good cheese. But this was probably due to an acuteness of the sense of smell possessed by the animal and not belonging to man. Indeed if a person tasted a cheese knowing that it was poisonous, he might detect a sharpness which would not ordinarily be noticed.

HAVE WE ANY READY MEANS OF RECOGNIZING POISONOUS CHEESE?

There is no certain means aside from a chemical examination, by which a poisonous cheese can be distinguished from a wholesome one. The most reliable ready method is probably that proposed by Dr. Vaughan a year ago and it is as follows: Press a small strip of blue litmus paper (which can be obtained at any drug store) against a freshly cut surface of the cheese; if the paper is reddened instantly and intensely the cheese may be regarded with suspicion. When treated in this way any green cheese will redden the litmus paper, but ordinarily the reddening will be produced slowly and will be slight. If the piece of cheese be dry, a small bit should be rubbed up with an equal volume of water, and the paper should then be dipped in the water. Dr. Vaughan does not regard the above test as free from error, but as the most reliable ready means now known. Every groceryman should apply this test to each fresh cheese which he cuts. The depth of the reddening of the paper may be compared with that produced by cheese which is known to be wholesome.

EFFECTS ON THE LOWER ANIMALS.

Dogs and cats, at least, are not affected by eating poisonous cheese. This is probably due to the fact that they do not get enough of the poison from the amount of cheese which they eat. The pure isolated poison in sufficient doses would undoubtedly produce upon the lower animals effects similar to those produced on man.

NATURE OF THE POISON.

Dr. Vaughan has succeeded in isolating the poison, to which

he has given the name tyrotoxinon (from two Greek words which mean cheese and poison). It is a product of slight putrefaction in the cheese which probably occurs in the vat, as the curd has been known to poison a person. By this slight putrefaction, or excessive fermentation, as it may be called, a large amount of butyric acid is formed, and this in the presence of the casein of the cheese is capable of developing poison. Different samples of poisonous cheese contain different amounts of the poison. The same weight of cheese from one cake furnished three times as much poison as that from another cake. The poison was obtained in long needle shaped crystals which are freely soluble in water, chloroform, alcohol and ether. The smallest visible fragment of a crystal placed upon the end of the tongue causes a sharp stinging pain at the point of application, and in a few minutes dryness and constriction of the throat. A slightly larger amount produced nausea, vomiting and diarrhea. The poison is volatile at the temperature of boiling water, and for this reason even poisonous cheese may be eaten with impunity after being cooked. The substance has also a marked, pungent odor, and through the nose one can obtain sufficient of the volatile poison to produce dryness of the throat. This is true, however, only of the isolated poison. In the cheese the taste and odor of the poison are both modified to such an extent that they would not be recognized as has already been stated.

The first step in the study of cheese poisoning has now been taken, by finding out what the poison is. Efforts will be made to ascertain the means for preventing its formation.

THE CLYNDOGRAPH.

The clyndograph of M. Moessard is a new panoramic photographic apparatus, which by a simple rotation of the objective gives the cylindrical perspective of the earth. A view furnished by the apparatus embraces an angle of 170 degrees, so that a complete turn of the horizon is obtained in two views and a fraction of twenty degrees range. The instrument is based on the principle that a lens or combination of lenses, constituting a photographic objective, may be subjected to any movement whatever without the image it produces on a screen changing its form or position, provided that the movement takes place around the nodal point, behind which it is maintained immovable. This follows from the known property of the nodal point being the point of view of the perspective produced. Suppose, then, there be (1) an objective suspended horizontally and turning round a vertical axis passing by its after nodal point; (2) two vertical shutters fixed behind to right and left of the objective, to limit the field in the horizontal direction and arrest rays too oblique; (3) a screen of cylindrical form vertically centred upon the axis of rotation, and having for radius the distance of the nodal point from the principal focus of the objective. In any position whatever of the objective the lie of the country comprised in the field of the instrument will be projected on the screen. If the objective be put in motion one gets successively for each point of the panorama an immovable image which impresses the eye or sensitive paper while the point remains between the two shutters. In M. Moessard's actual apparatus Teibaut sensitive plates are used to receive the impressions. The instrument is expected to prove useful in preliminary surveying and military operations.

NO PANAMA CANAL.

The London *Financial News* has been looking into Panama canal facts and figures and reaches some interesting conclusions. M. de Lessep's calculation was that, beginning in 1881, the canal could be built in eight years at not exceeding \$120,000,000 of cost. In June, 1883, the date of the last official report, \$43,900,000, or over one-third the total estimate, had been spent and just about one per cent. of the excavation was done. Up to June, 1885, the *News* learns, the total expenditure had been \$104,033,000, or five-sixths of the total estimate, and the work done was one-tenth of all that will be necessary. The *News* goes on, allowing for the heavy extra cost of tide locks, retaining walls against the Chagres river, etc., and concludes that not less than \$525,000,000 will be required, or would be, to complete the work. It thinks this never will be raised and that the canal will never be finished, and that, if finished, it could not pay.

THE SMITH VENTILATOR FAN.

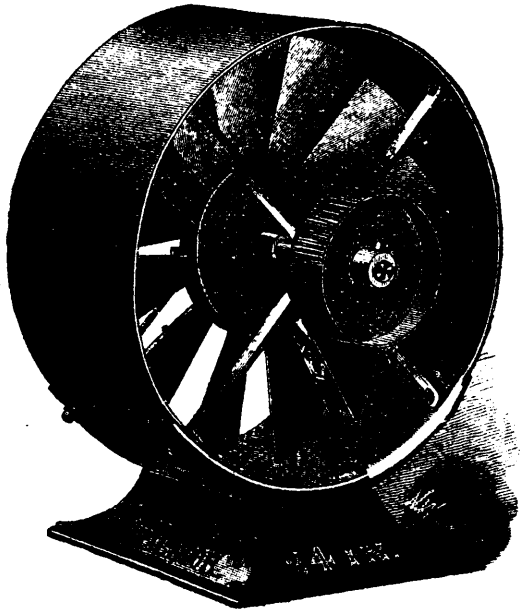

FIG. 1.

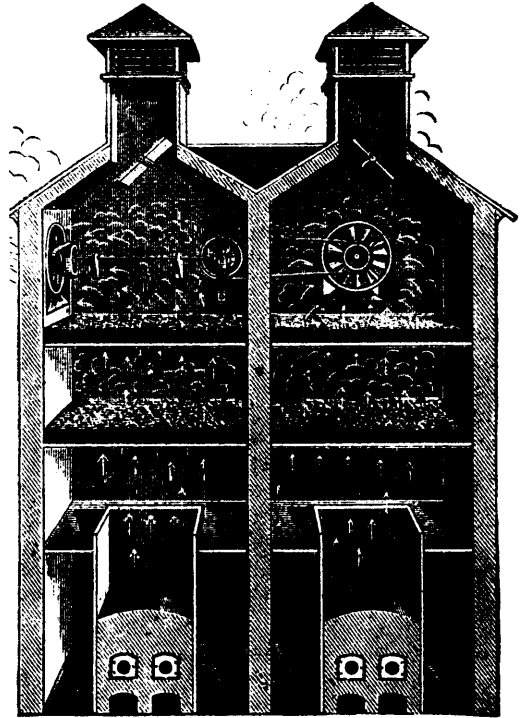

FIG. 2.

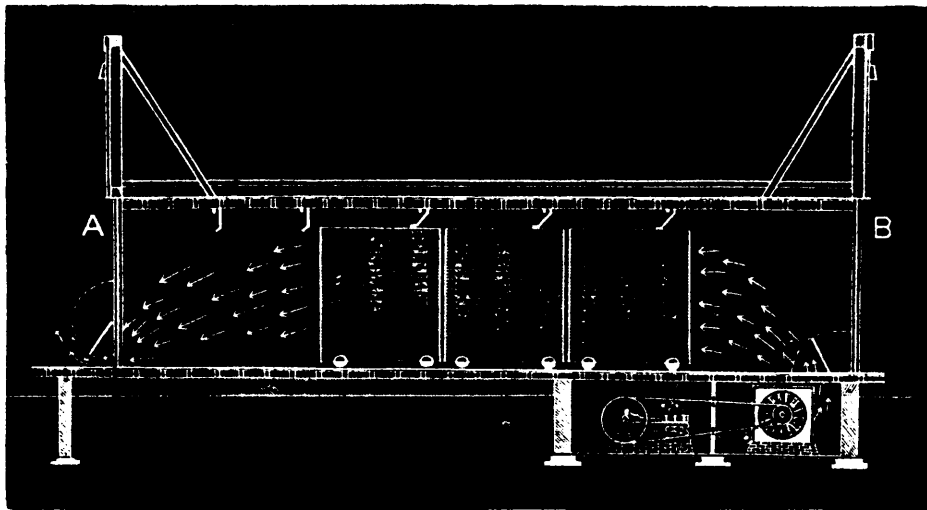

FIG. 3.

THE SMITH VENTILATOR FAN.

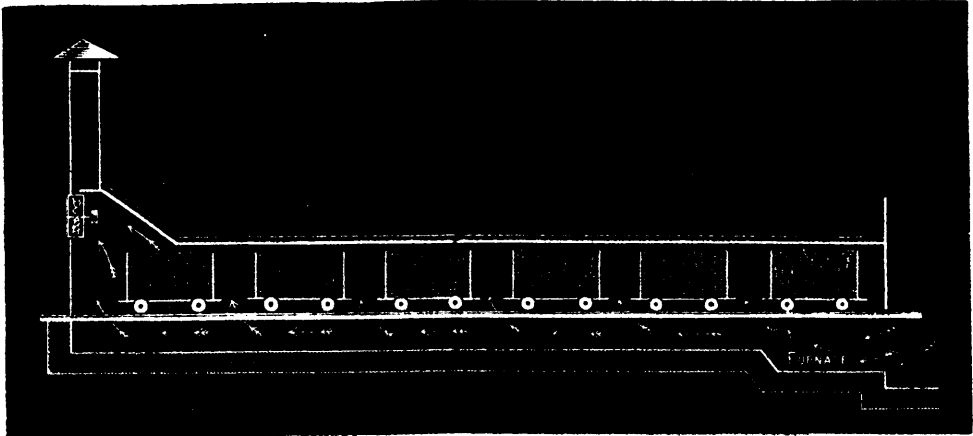

FIG. 4.

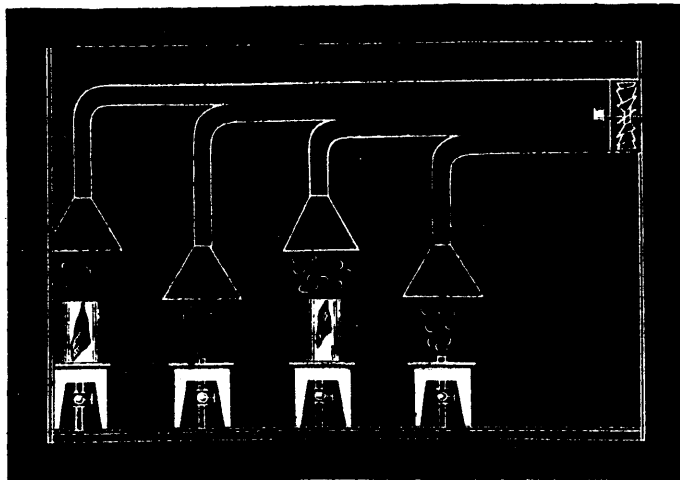

FIG. 5.



FIG. 6.

THE COMPASS IN IRON SHIPS.

The Philadelphia *Times* gives an interesting account of a curious industry—adjusting the compasses of iron ships. The business, it says, is monopolized by three persons in the United States—two in New York and one in Philadelphia. An iron ship, said one of these professionals, is a great magnet. The Magnetism of such a ship is technically known as "permanent," from having received the same from some other magnet itself styled permanent. The position the vessel occupies in the shipyard while in course of building is the principal feature in the shaping of her magnetic influence. It may seem incredible, but a vessel lying due north and south on the stocks will be highly charged with magnetism—so highly, in fact, that the nicest calculations and most skillful adjustment of neutralizing magnets is requisite to correct its influence on the compass, and with the greatest care errors are made, which involve more or less trouble in the directing of the ships' course.

Every blow struck upon the iron plates of the sides, upon the rivets, or even by the calker, has a pronounced effect upon the ship's magnetism. It is well known that in certain processes of iron working, workmen, after striking the metal in one direction for a few minutes, are compelled to reverse the direction of their blows so as to change the polarity in order to prevent the fine particles of loose metal from adhering to their tools. In ship building it is impossible to reverse the manner of striking, and the result is that the magnetic currents are not equalized.

If a vessel that was built north and south in the yard travels generally north and south she loses a great portion of her magnetism, and a corresponding change is noticeable in her compass.

The lines of magnetism always run in a contrary direction to the position the ship occupied in building. It is said that the quality, ductility and grain of the metal used in the construction of the vessel have a great deal to do with the magnetic currents. It sometimes happens that the greatest accuracy that can be secured will not prevent a variation of three or four points from the true point. Occasionally it happens that, for illustration, a variation of but one point will be noticed when the ship is headed northeast, but when headed southeast five or six points of variation exist. The magnets used to neutralize the ship's magnetism consists of large bars of iron, spheres, spheroids, coils and, in fact, iron of almost every shape. These are placed in different portions of the vessel and exert a greater permanent influence the further away they are placed. When placed near the compass they "make the needle wild." If the engines are changed during the trip, if new boilers are shipped, iron taken aboard or "patches" put on the sides, the magnetism of the ship is proportionally disturbed and a readjustment is necessary. Usually an adjustment for all practical purposes will secure safety, so far as the compass is concerned, for a year or probably longer; but cases are reported where iron ships but forty-eight hours out from port have been wrecked in consequence of a change in the ship's magnetism producing a variation of the needle not calculable. These are rare, however.

ELECTRIC LAUNCHES IN THE RUSSIAN FLEET.

As a result of experiments made by the Russian War Department last summer at Cronstadt with electrical launches, a part of the Russian cruising fleet has been supplied with these vessels, to be used for night attack. The design is by Lieut. Treitinoff. Each launch carries an electric battery of 200 accumulators, which, section by section, are capable of furnishing propelling power for from 15 to 20 hours, and, with a velocity of from five to six knots the launch is good for from 75 to 100 miles.

These launches have been found peculiarly adapted for carrying an armed crew on warlike expeditions at night, because, unlike the steam launch, they make no noisy puffing and are good for a long distance. Boats, even with muffled oars, are more or less noisy, and, besides, are very slow. Here, then, is a case where the electric launch is invaluable, because economy, of course, is not a requirement, speed and silence being the requisites.

We are not told how many men these launches will carry, nor how many are assigned to a single vessel. They can be swung over the side and launched from davits like ordinary boats, the men boarding after the launch is safely afloat.—*Bulletin des Telephones*.

THE CAUSE OF DEPRESSION IN ENGLAND.

At a time when the government of the country is taking in hand an inquiry as to the causes of trade depression, with a view to see if any thing can be done in the way of legislation to remedy this trouble, it may be well to see if any such inquiry is necessary, and whether the cure is not very much within our own reach. The causes of depression are not difficult to trace. During the last five years capital and enterprise all over the world have stimulated production in a ratio greater than the increase of population, and the consequence is seen in low and unprofitable prices. This country has suffered in several ways in consequence of the active competition of our continental neighbors and our enterprising American cousins. To meet this some would place a duty on all manufactured articles imported into this country; but this would not relieve us from this competition, as it would only break out in another place. It is well known that we are suffering from this competition in foreign markets, where we do a large trade, and any impost such as is proposed, whilst increasing our trade for home consumption, would raise prices, and thus the better enable our competitors to take larger share of our foreign trade, whilst at home we would be paying higher prices in consequence of the duty which would be imposed; so that, all round, we should be considerable losers by such an operation. The cure is in our own hands. This competition must be met and overcome in a fair fight with our opponents. As regards America, the difference is due more to that talent and skill of inventors who are always designing something new and attractive, and if our manufacturers would only get out of their old-fashioned ways and allow skill the same play here, there is no doubt we could meet this competition easily, for it is no secret that the English article, if not so attractive, has the element of durability about it. The continental competition is more serious we fear, as it is based on the decided advantage which they enjoy in the matter of wages as well as the wonderful energy and push which they show in all foreign markets. It is not to be expected that English workmen will accept the low wages ruling on the continent, and fortunately it is not necessary, as it is generally admitted that our labor is considerably the more efficient of the two, still there is no concealing the fact that even after all due allowance is made for this difference wages in England are relatively higher than on the continent. Although we cannot but rejoice in the higher standard of comfort attained by our working classes during the last few years we must also recognize the fact that if absolutely necessary they may have to submit considerable reduction in wages to meet that competition which is now being seriously felt in all branches of trade. It is fortunate for them that all articles of prime necessity are now so low in price and there is little doubt, if present hard times continue much longer, they will make their mark on rents, prices of clothing, etc., etc.

Another serious matter affecting our staple trades is the question of railway rates, rents, and royalties. These will have to be dealt with sooner or later in accordance with the spirit of the times. It is absurd to suppose that whilst everything else suffers a serious reduction these important changes are to remain fixed and unchangeable. To bear fairly on trade the principle of the sliding scale ought to be introduced, so that all may bear their fair share of bad trade and benefit when the good times come. There is little doubt, with a slight readjustment of wages, railway rates, and royalties, all the great industries of this country would be able to hold their own in the great struggle which is now going forward, and the end of which does not seem very close at hand.—[*London Iron Trade Exchange*.

STRANGE BUT TRUE.

This is one of the curious things floating about: take a piece of paper, and upon it put in figures your age in years, dropping months, weeks, and days. Multiply it by two; then add to the result obtained to the figures 3,763; add two, and then divide by two. Subtract from the result obtained the number of your years on earth, and see if you do not obtain figures that you will not be likely to forget.—*Sc. Am.*

A varnish compound of 120 parts of mercury, 10 parts tin, 20 parts green vitriol, 120 parts water, and 15 parts hydrochloric acid of 1.2 specific gravity furnishes a good coating for iron exposed to the wet.

THE VICTOR CALORIC ENGINE.

The mechanical construction of the Victor engine is shown in the sectional view. Though novel in form and adjustment, the arrangement of the parts is extremely simple and effective. Its general plan is entirely novel, as it is the first upright double crank hot air engine ever introduced in the United States, though the Victor engine has been in successful use in England for some years. The piston chamber is entirely closed at its lower end by the heater which is in the form of a drum. Above the heater there are substantially only two working parts—a main piston and a piston of peculiar construction which acts as a combined displacer and regenerator. The main piston runs up and down in the upper part of the piston chamber which is surrounded by a water jacket and kept cool, forming the cooling portion of the cylinder. This main piston does not materially differ from an ordinary steam engine piston. It is packed with steel rings so that there is no leather packings to burn out, and the piston is as durable as any piston can be made. The steel rings adjust themselves to wear on the cylinder so that there can be no leakage until the rings are worn out, and they can then be replaced easily at trifling cost. The lower piston or regenerator is composed of a flat cap which fits the cylinder, and a few inches below this a cast iron conical cap, which, when the piston is down, comes over the dome shaped heater, while a thin iron cylinder connects the sides of the upper cap and the lower end of the conical cap, while the space thus formed between the upper cap, the lower conical cap and the sides of the thin iron cylinder is filled with wire gauze. The whole regenerating piston is kept together by the rod which is screwed into the upper end of the lower conical cap, then passes through the wire gauze, then through the upper flat cap which is solidly fastened to it, then passes upward through a stuffing box in the centre of the main piston, and then through the guide which is bolted at the top of the piston chamber in the form of a bridge. To this rod is attached its connecting rod which is itself connected with the crank shaft and so imparts motion to the regenerating piston. There are small holes in the top of the regenerating piston and also small holes in the sides of the same piston near the bottom so that the air may be forced in small jets back and forth through the wire gauze which fills the piston. Motion is imparted to the main piston by a connecting rod attached at one end to the crank shaft and at the other to the piston. The two cranks of the shaft are set an angle of ninety degrees apart. These two pistons—the main or upper piston, and the lower or regenerating piston—are all the working parts within the piston chamber. Both pistons are substantially made very durable, no more liable to wear out than a steam engine piston, and if broken by any accident can be quickly replaced at small cost. The lower port of the piston chamber, below the water jacket, has an interior lining of asbestos, which is made by rolling asbestos cloth on a mandrel, and is hard and more durable than any metal. This is one of the novel and most valuable features of the engine. Many compositions of metal have been tried and patented for use as a lining to these hot air chambers in caloric engines, but none have been fully satisfactory. The Victor Engine Company hold an exclusive right to use the interior lining of asbestos, as well as the exclusive right to use double crank in combination with the two pistons described.

The engine is used with either gas or kerosene as fuel, and can be adapted for coal. The dome form of the heater allows the heat to be concentrated in the most effective way. In using gas a Bunsen burner is used, as shown in the diagram. One gas tip or burner is used, but this is placed in a large cast iron tube which opens to the outside of the base and at the inner end extends upwards inside the dome of the heater. At the upper end this tube is curved with wire gauze similar to the gauze used in miners' lamps. The gas tip is inside the tube and several inches below. The air draws through the tube and mingling with the gas from the gas tip, the combined gas and air pass through the gauze and is lit on top, thus giving perfect combustion and great heat from a small amount of gas. The flame strikes directly upon the top of the under side of the heater, and whatever results of combustion there are passed down the sides of the under part of the heater and up through the chimney. No particle of the results of combustion can reach the interior of the heating chamber, so that the pistons are never clogged or made gummy. The heater is made intensely hot and as the regenerating piston curves down over its top, the air is quickly compressed upon a red hot surface and as quickly expanded by the intense heat and drives the regen-

erating piston upward with great force. As soon as this piston starts upwards the hot air rushes through the perforations in its side near the bottom, is driven through the wire gauze which takes off much of the heat and then rushes in small lots through the holes in the upper part of the same piston against the sides of the cooling chamber and is quickly cooled and condensed. A vacuum is created and at the same time the main piston and the regenerating piston come together and the air is forced down again through the wire gauze, taking up the heat again when the same process is repeated. The expansion of the air imparts force to each piston in succession and the air is used over and over again with no change, except as a very small portion of air is let in at each stroke from a small automatic valve in the side of the engine. In this manner a larger amount of force is developed than has before been obtainable from hot air. The No. 1 engine has but a six inch cylinder and is only three feet — inches high, yet will force 300 gallons of water per hour 50 feet high with small consumption of either gas or oil. The heating chamber is made still more perfect by an outside coating of asbestos cement. The engine runs at high speed, the crank shaft making regularly 250 revolutions a minute, and consequently a governor is required and used. We believe no hot air engine has hitherto attained any such speed and governors have therefore not been used on other hot air engines. The engine has also a novelty in the shape of a small lever, which upon being moved allows the pressure to escape and the engine stops, and which is simply closed when it is desired to start the engine. The engine has been used in England chiefly as a motor, and is intended to be used also as a motor here, but the company have fitted some of their engines to be used for pumping water by taking the pulley off from the crank shaft and attaching a pump to the side. The engine can, however, be used effectively in either way. It runs noiselessly, swiftly and with great regularity. It is small, compact and solid, and seems in every respect to fill the requirements as a practical working engine.—*Chicago Journal of Commerce.*

WOOD CRYSTALS.

Chemical analysis has long since detected the presence of various mineral substances—potash, soda, silica, etc.—in many forms of vegetable growth; and the main source of potash at present, as of soda in former times, is the ashes of certain trees and plants. It also appears, as the result of microscopic investigation, that many of these mineral salts retain or assume a crystalline form even when imbedded in the solid portion or bark of certain plants, as the microscope most unmistakably reveals. Should it be proved that the form these crystals assume is regulated or modified by the conditions and character of the growth which incloses them, it is evident that the fact would be one of great interest to science, and of peculiar value and service to the druggist, since it would enable him to determine the nature and purity of any medicinal bark or wood, by examining a crushed sample under the glass, and comparing the forms of the crystals with those presented in a series of standard plates. Thus the absence of the desired crystal, or the presence of others differing in form from the standard, would enable him to determine the nature and extent of the impurity or adulteration. A new study is here opened up.

GIMLET-POINTED SCREWS OF 1755.

Mechanics of adult age can easily remember when gimlet-pointed screws came into use within the last 30 years, superseding the blunt pointed ones before used, and the former have been considered a modern invention. But we have lately seen half a dozen screws with excellent gimlet points, which were taken from an old piano, and bear unmistakable evidences of age, and of having been made before screws were made by machinery. The piano is inscribed "Jacobus Kirekman, Fecit, Londini, 1755," and the screws are doubtless of that date. The most curious point in the case is that after such screws as these had been once made mechanics should have gone on using square-pointed screws for nearly a century.—*Worcester, Mass., Gazette.*

—The *Philadelphia Record* says: Messrs Cockburn & Co., of Newcastle, England, have introduced the Maxim-Weston electric light into the Backworth and Ashington and the Page Bank collieries with complete success. This promises to lessen the severe the casualties to which the collieries are subject.

THE SMITH VENTILATOR FAN.



FIG. 7.

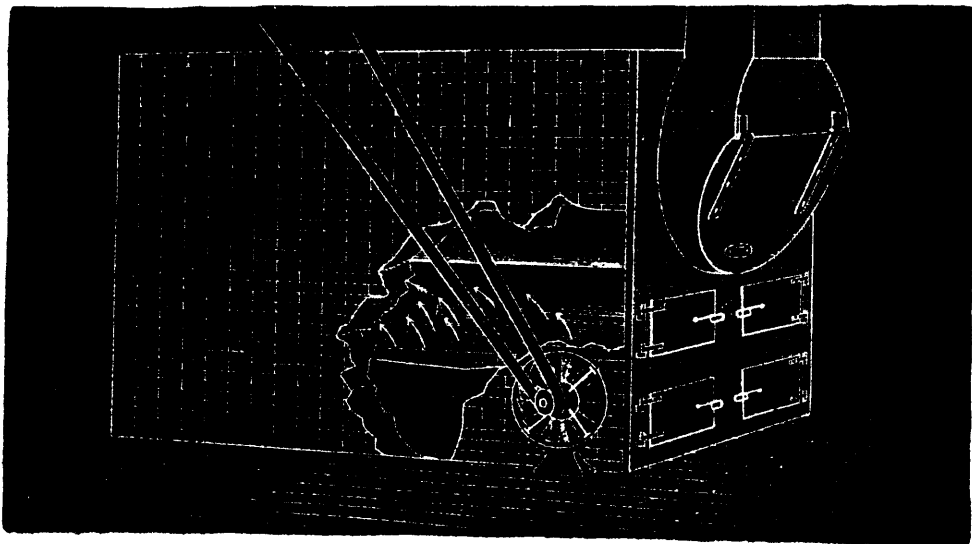

FIG. 8.

THE "VICTOR" CALORIC ENGINE.

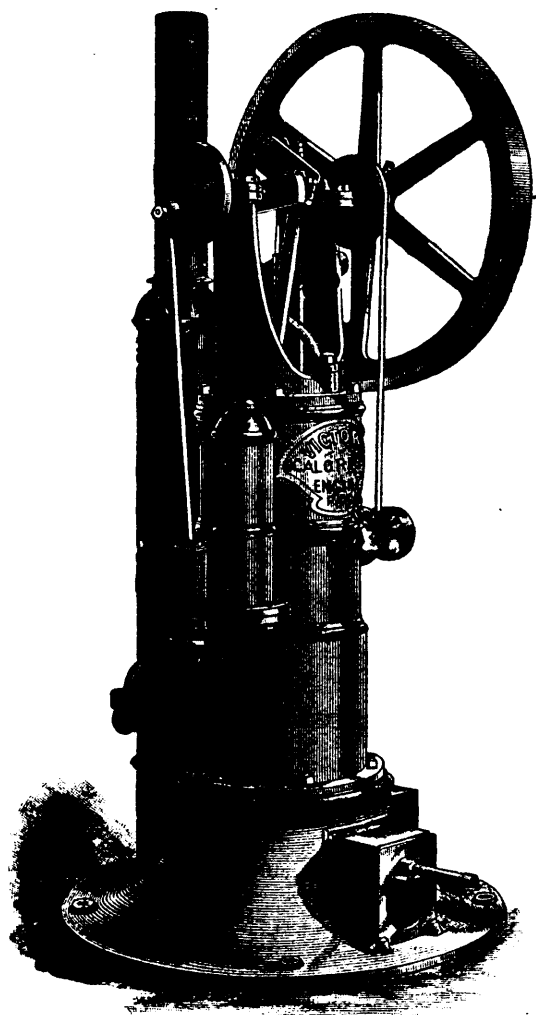

Fig. 1.—Perspective View.

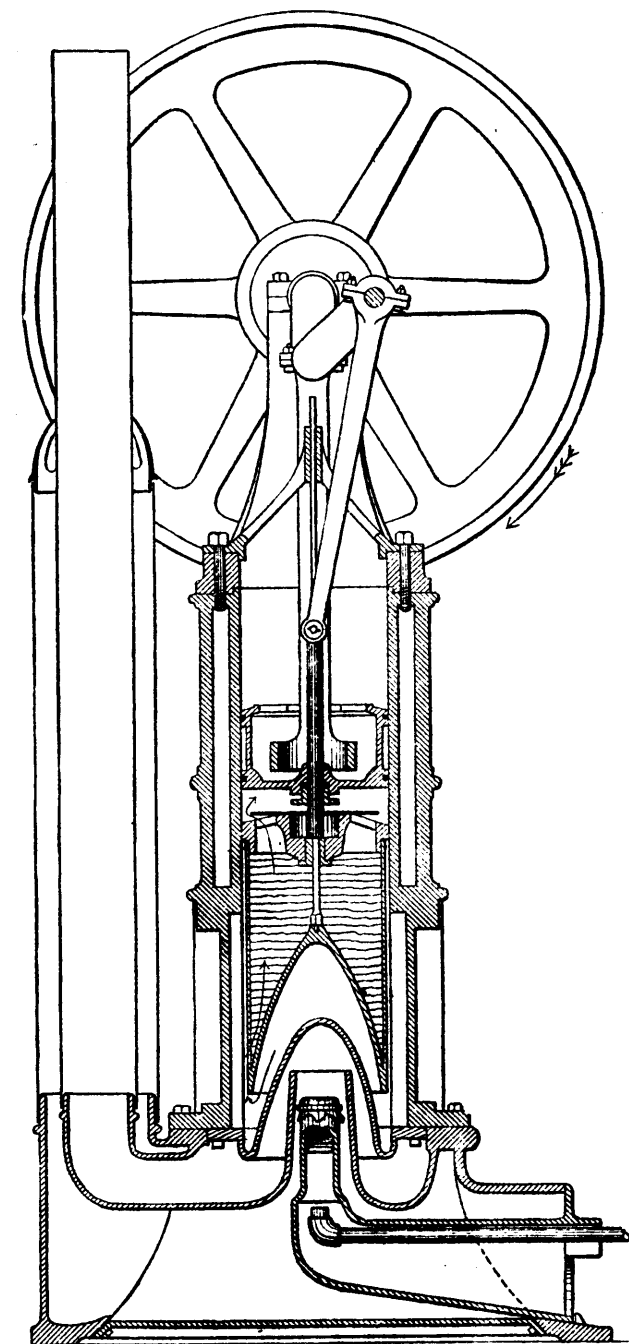

Fig. 2.—Longitudinal Section.

DIFFERENTIAL ENGINE.

This engine not only displays entire novelty of conception, departing from the received practice both of steam and gas engines, but obtain it results, so it is stated, with great economy in the consumption of gas, and by the simplest possible combination of parts. Compression gas engines have hitherto been constructed in such a manner that they compress a certain amount of gas and air, or gas, air, and residuum from a previous explosion, into a cavity in the end of the cylinder, ignite this charge, and obtain work on the crankshaft from the increased pressure due to the higher temperature during the whole of one stroke or half a revolution, during which time the charge is expanded to the original volume. After this the whole contents of the cylinder are allowed to pass into the exhaust pipe at a pressure of 30 lb. to 40 lb. above the atmosphere and at a very high temperature. The well-known "Otto" engine was placed before the public some seven or eight years ago, and other engines followed it, possessing the same features in these respects, that is to say, expanding the charge to the original volume in half a revolution.

Mr. Atkinson argues that substantially the utmost limit of economy in any engine working in this manner was reached in the "Otto" engine some years ago, and that, unless some other system of working were introduced, no further economy could be attained. The great source of loss in the ordinary gas engine results from the cooling action of the cold-water jacket around the cylinder, and to reduce this, Mr. Atkinson designed the engine shown in diagram in Fig. 1 to 4, and in plan and elevation in Fig. 5 and 6 on the next page, his object being to allow the gases to expand much more rapidly than usual, and thus to be in contact with the cold cylinder walls for a shorter period. Referring to the engravings, it will be seen that the cylinder is open at each end, and is fitted with two pistons. The are connected by doubled-ended levers and short connecting rods to one crank-pin. The short connecting rods are an essential feature of the design, as it is through their action that the peculiar differential motion of the pistons is obtained. The pistons travel in the same direction, but at very different relative speeds; when at the outer end of their strokes, they remain almost at rest for nearly half a revolution of the crank-pin, but travel rapidly when at the inner ends of their strokes. When the two pistons have completed the strokes to the right (Fig. 1), they almost touch each other, and have driven out the products of the previous working stroke through a port in the cylinder wall, so that the hot residuum that frequently causes violent premature ignitions, is completely expelled. The crank-pin is at this time on the left, and as it proceeds towards the highest position, the left-hand piston moves rapidly away from the other, leaving a space between them into which gas and air are drawn in suitable proportions through a self-acting suction valve. At this point (Fig. 2) the right-hand piston travels past, and closes the openings to the suction and exhaust valves; and during the next quarter revolution the pistons again approach each other, compressing the charge between them to about 60 lb. pressure, the crank being now on the right-hand side (Fig. 3). At the time of greatest compression the left-hand piston passes the opening to an igniting tube (Fig. 3), which causes the ignition, and an immediate rapid working stroke is made by the right-hand piston, and is completed by the time the crank-pin arrives at the bottom (Fig. 4). The exhaust port is now opened by the continued travel of the piston, and the contents of the cylinder driven out through the self-acting exhaust valve by the left-hand piston, which is now in the position first mentioned, the complete cycle being completed in one revolution.

The place between the pistons into which the ignited charge expands, is nearly double the space into which the charge is drawn, consequently the expansion is continued to nearly twice the original volume, and instead of the exhaust being emitted at 30 lb. to 40 lb., it is expanded down to 10 lb. or 12 lb. It will be seen also that the total expansion to twice the original volume takes place in one-fourth of a revolution as compared with other engines which expand to the original volume only in half a revolution, consequently the expansion to the original volume is done in one-fourth of the time, assuming the engine to run at the usual speed. The economy to be gained from the extra expansion is obvious, while the saving due to rapid motion of the piston was demonstrated in the early part of 1883 by Mr. Witz, who made some experiments with a view to determining the effect of increased rapidity of expansion. In one series of experiments he used a mix-

ture of one volume of illuminating gas and 6.33 of air, a very usual proportion in gas engines. This mixture was drawn into an experimental cylinder and exploded, the piston being allowed to travel at the rate of 1.7 metres per second, corresponding to an ordinary piston speed in a medium-sized gas engine, and by means of the diagram he estimated the actual amount of work done. He increased the speed of piston to travel 4.3 meters per second, or 2.54 times as fast, the same amount of gas did 2.9 times as much actual work. This enormous increase is chiefly due to the fact that the intense heat of combustion is not allowed to continue so long in contact with the walls of the cylinder, cooled by the water jacket. It is well known that more than one-half of the total heat in the gas, even if thoroughly consumed, is lost by transmission to the water. If the work is done in one-fourth of the time, three-fourths of this serious loss must be saved, the transmission of heat through metallic substances being directly proportionate to the length of time the differences of temperature exist; hence the great increase of power shown by Mr. Witz's experiments.

It is clear that Atkinson's "differential" engine is a great advance from a theoretical point of view, and from a practical one we understand that the British Gas Engine and Engineering Company, of 11, Queen Victoria-Street, E. C., who manufacture them, are prepared to guarantee a considerable saving in gas.

From an inspection of the illustrations it will be seen that the engine is extremely simple; there is no slide valve, a fact that any one practically acquainted with the working of gas engines will appreciate, nor is there any complicated substitute, the working fluid being efficiently controlled by the pistons passing the ports to the two self-acting valves, and the port to the igniting tube; in fact it is more simple than any steam engine. There are no joints under pressure, no delicate passages, no cams or eccentrics; and it has only pistons and bearings for the wearing parts.—*Eng.*

THE RATE OF RECESSION OF NIAGARA FALLS.

Writing to Nature, Mr. Edward Wesson, of Providence, R. I., discusses the question of the rate at which the Niagara Falls recede Southward, uses as a basis the outline of the falls as determined by the New York Geological Survey of 1842, the United States Lake Survey of 1875, and by Thomas Evershed for the New York Commission in 1883. He finds as the mean of the measurements of a number of sections along perpendiculars from the contour at the date of each survey, for the Canadian falls, 2½ feet per annum for the 33 years ending 1875, 7½ feet for the 8 years ending 1883, and 2½ feet for the 41 years ending 1883. The American falls, measured in ten sections, gave a total mean recession of 37½ feet in the 41 years ending in 1883, which is at the rate of about 10 inches per year. Mr. Wesson says: "I do not know that I have seen any estimate attempted of the relative volumes of water passing over the two falls. From such imperfect data as I have referring to depth and swiftness I should think that the rate of erosion for each fall give some approximation to the volume of water discharged over each; that is to say, 2½ feet per annum for the Canadian fall, 5.6 foot per annum the American fall, would signify that the former pours over its brink three times as much water as the latter. At the rates of recession above shown it is evident that at no very remote age the two falls were united in one, and the entire width was about the same as that of the present Canadian fall alone. Moreover, the mean width of the fall, from the time it commenced its work at the "heights," 7 miles below its present position, according to Lyell's statement as to the gorge of Niagara River, was not greater than the present Canadian fall. Adding together the present work done by both falls, we should have about 3½ feet per annum as the backward work performed when the entire volume poured over single fall of the width of the present Canadian fall. At this rate 10,000 years would seem sufficient time for the cutting out of the present gorge terminating at the "heights" toward Lake Ontario, instead of Lyell's estimate of 35,000 years. All attempts to calculate the rate of movement proceed on the assumption that the hardness of the limerock and shale, the volume of water and the height of the fall were for the whole distance much the same as they now are; I merely use these same assumptions. It in no wise reflects on Lyell's judgment that he should have erred so greatly in attempting to estimate the rate of regressing, while yet the contour of the fall at different periods had not been fixed

by triangulation. He was ever the first to lay aside a conjecture when he could lay hold of something more solid in its stead, and it was by his candor and sound judgment in discussing natural phenomena that my interest in such matters was awakened. The statement made by him that Hooker, his guide in 1841, reported that an indentation of 40 feet had been made in the American fall since 1815 seems to contain the basis on which he estimated the rate of regression for both falls, as this amounts to a little over 1 foot per annum. A reference to the results given by me show this to have been approximately correct for the mean rate at the American fall, but wholly inapplicable when applied to the much more important Canadian fall. A consideration of his section of the Niagara River leads me to suppose that the falls in the earlier part of their history worked even more rapidly than now in undermining the brink.—*Chic. Jour of Commerce.*

IMPROVED TRACTION ENGINE AND CRANE.

At the recent Agricultural Show, Preston England Messrs. Aveling and Porter, of Rochester, had a large collection of engines, and among them an exceedingly handy crane engine, of which we give a perspective view, from *Engineering*. This engine, which is rated by the makers as a 6 horse, has done excellent work in getting exhibits into position, the crane with which it is fitted being capable of lifting loads of three tons, and both lifting and slewing by power. The arrangement of the gear is ingenious. The hoisting barrel is mounted on the crane jib, and is geared to a pinion running on the vertical around which the jib slews this pinion being fixed to a sleeve having a disk cast on it as shown. This disk is situated between two other disks, that above it being made solid with the bevel wheel to which the hoisting motion is communicated from the engine, while the lower disk is fixed on the central spindle forming the crane post, this spindle carrying at its upper end a quadrant geared into by a worm as shown, this worm giving the slewing motion. To the central disk first mentioned is fixed a bracket forming the fulcrum of a pair of levers actuating friction clutch gear as shown, these levers when depressed causing the central and upper disks to be frictionally connected and thus making the hoisting motion available, while if raised the levers frictionally connect the central and lower disks, so forming a brake by which the load is upheld. The hoisting and slewing motions are both driven from a diagonal shaft which extends to the rear of the engine, and which is geared to the crankshaft so that it is always running while the engine is in motion. On this diagonal shaft are carried two bevel pinions, one giving the slewing motion to the right and the other to the left; by an arrangement of taper keys actuated by a clutch lever, either of these pinions can be driven as desired, and the load may be slewed in either direction, while the hoisting or lowering is going on. The whole arrangement is exceedingly neat and convenient and the engine is capable of doing a vast amount of work. It is shown fitted with one of Priestman's diggers, which it is well adapted for working. With one of these diggers the engine has unloaded easily 70 tons of coal from a barge in a day of eight hours.—*Sc. Am.*

THE ALACRITY.

The Alacrity, twin screw steel dispatch vessel, 1,400 tons displacement, which recently arrived at Portsmouth from Jarrow-on-Tyne, where she was built by the Palmer Shipbuilding Company, has just completed her highly successful series of steam trials in the Solent. The trials were conducted by Mr. J. P. Hall, on behalf of the contractors, and among those present on the occasion were: Mr. Bakewell, from the Admiralty; Commander the Hon. F. R. Sandilands, in command of the ship; Mr. Alton, Chief Inspector of Machinery; Mr. Connor, of the steam department of the dockyard; and Mr. J. Smith, chief engineer of the ship.

The Alacrity is a sister ship to the Surprise, the only material difference being that her bunker capacity is somewhat less. She will carry 375 tons, as compared with the 400 tons of the Surprise; but even this reduced quantity will enable her, it is supposed, to steam 15 knots for about 14 days. The vessel is propelled by two sets of compound engines, each having a high-pressure cylinder, 26 inches in diameter, and one low pressure cylinder, 50 inches in diameter, with a stroke of 34 inches. The main engines are horizontal each pair being fitted with

a horizontal air pump driven from the crank shafts. Her crank shafts are of Vickers steel, while the propeller shafting and the cylinder liners are made of Whitworth fluid compressed steel.

The propellers themselves are composed entirely of gun metal. There are two large horizontal condensers, formed also of gun metal, the water being circulated by two pairs of centrifugal pumps made by Allen. The fans and casings are likewise made wholly of gun metal. The pumps are fitted with large suction from the bilges, and are thus capable of dealing with a considerable leak. Four special engines are provided for feeding the boilers, while two others of similar design pump out the bilges, and can also be employed as fire engines. The main engines are fitted with steam reversing gear of simple construction, and can be handled very easily. The piston and other glands are packed with the new patent asbestos cloth packing. Steam is provided by four steel boilers, two being 9 feet 6 inches in diameter, and two 10 feet 4 inches, the length of all being 17 feet 6 inches. The working pressure is 100 pounds to the square inch. The stokeholes are fitted with arrangements for forced draught, the air being supplied by four centrifugal fans, 4½ feet in diameter, driven by an independent engine. These are capable of maintaining an air pressure equal to 2 inches of water.

The natural draught trial was made under favorable auspices as regards weather, the immersion of the ship being 11 feet 2 inches forward and 10 feet 6 inches aft. The engines were kept working at full power continuously for four hours, the means of the observations giving the following results; Steam in boilers, 92.63 pounds; vacuum, 26 inches and 25 inches; revolutions, 121 and 120 in the starboard and port engines; horse power, 1,087 and 1,070 horses in the two engines respectively, thus showing a collective power of 2,157, equal to 157 more than the contract, with a fuel consumption of 21 pounds per unit of horse power developed. Her speed realized was 16.143 knots. At the four hours' continuous trial under forced draught very gratifying results were obtained without the engine, to use an expression borrowed from the turf, turning so much as a hair. The air pressure in the stokeholes did not exceed an inch as measured by the water gauge, but with this a perfect combustion was secured in the furnaces, and no want of steam was experienced.

The mean pressure in the boilers on the occasion was 99.31 pounds, about equal to their full working pressure, the vacuum 25.1 inches and 24.5 inches, the revolutions 134.86 and 134.71 per minute, the horse power 1,565.73 and 1,807.34 in the starboard and port engines respectively, and the total collective power indicated 3,173.07 horses, or nearly 200 beyond the contract. The two engines worked well together, but the mean pressure in the cylinders of the port engine were somewhat higher than those of the starboard engine. The fuel consumption was 2.77 pounds per horse per hour, and the speed obtained on the mile was 17.956 knots. Favorable as were the results extracted from the Surprise, as regards power, speed, and economy of coal, they were exceeded by the performances of the Alacrity. The engines worked admirably from first to last, and, notwithstanding the enormous piston speed, the bearing showed no signs of heating.

On the conclusion of the run, the turning powers of the ship were tested under full speed. Circling to starboard, the circle was completed in 4 minutes 5 seconds, the port circle being performed in 4 minutes 24 seconds.

The approximate diameters were 500 and 700 yards, or about from six to seven lengths of the ship. At the end of the trial the Alacrity returned into harbor, when she will be completed to replace the Enchantress as Admiralty yacht. As it proposed, however, to arm her and her sister ship, the Surprise, with six 5-inch breechloading guns and four 3-pounder quick-firing guns, she will not be ready for the use of their lordships on their forthcoming visits of inspection to the dockyards.—*London Times.*

STANLEY says the length of the Congo river is 2,100 miles and that the Mississippi and the Nile together would scarcely equal its tribute of water to the ocean. From the mouth of the river a steamer drawing fifteen feet can steam up 110 miles, at which point a land journey of fifty-two miles is taken on account of the rapids. Then another standing or rowing voyage of eighty-eight miles occurs, which is succeeded by a land journey of ninety-five miles. After that it is possible to steam up another 1,060 miles. Along this route thirteen stations have been constructed among peaceful tribes.

ATKINSON'S DIFFERENTIAL ENGINE.

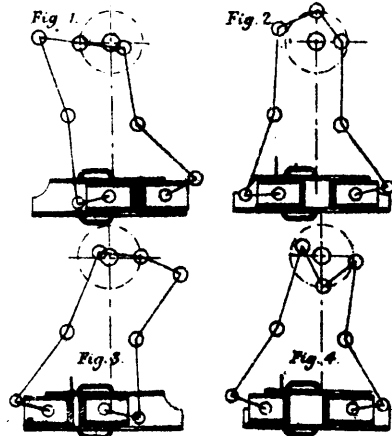
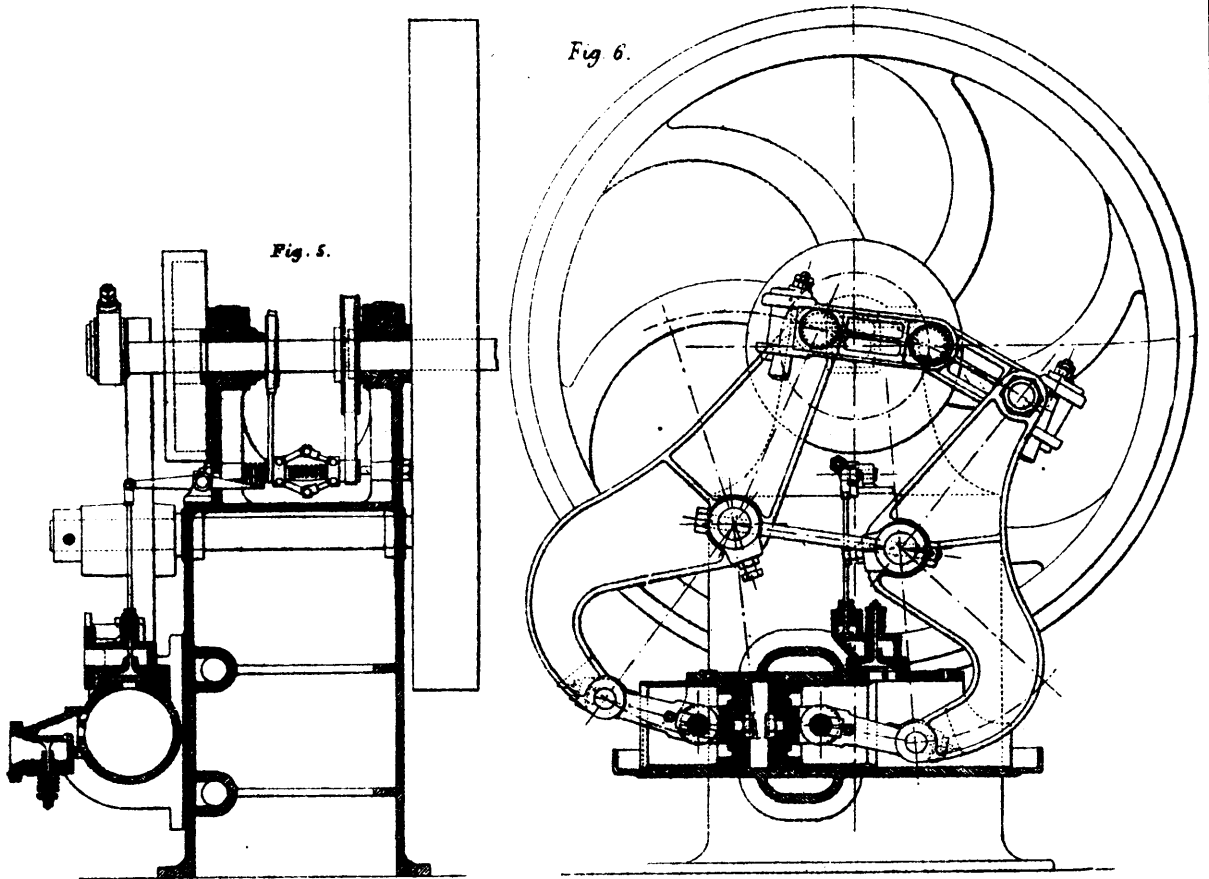

IMPROVED TRACTION ENGINE AND CRANE.

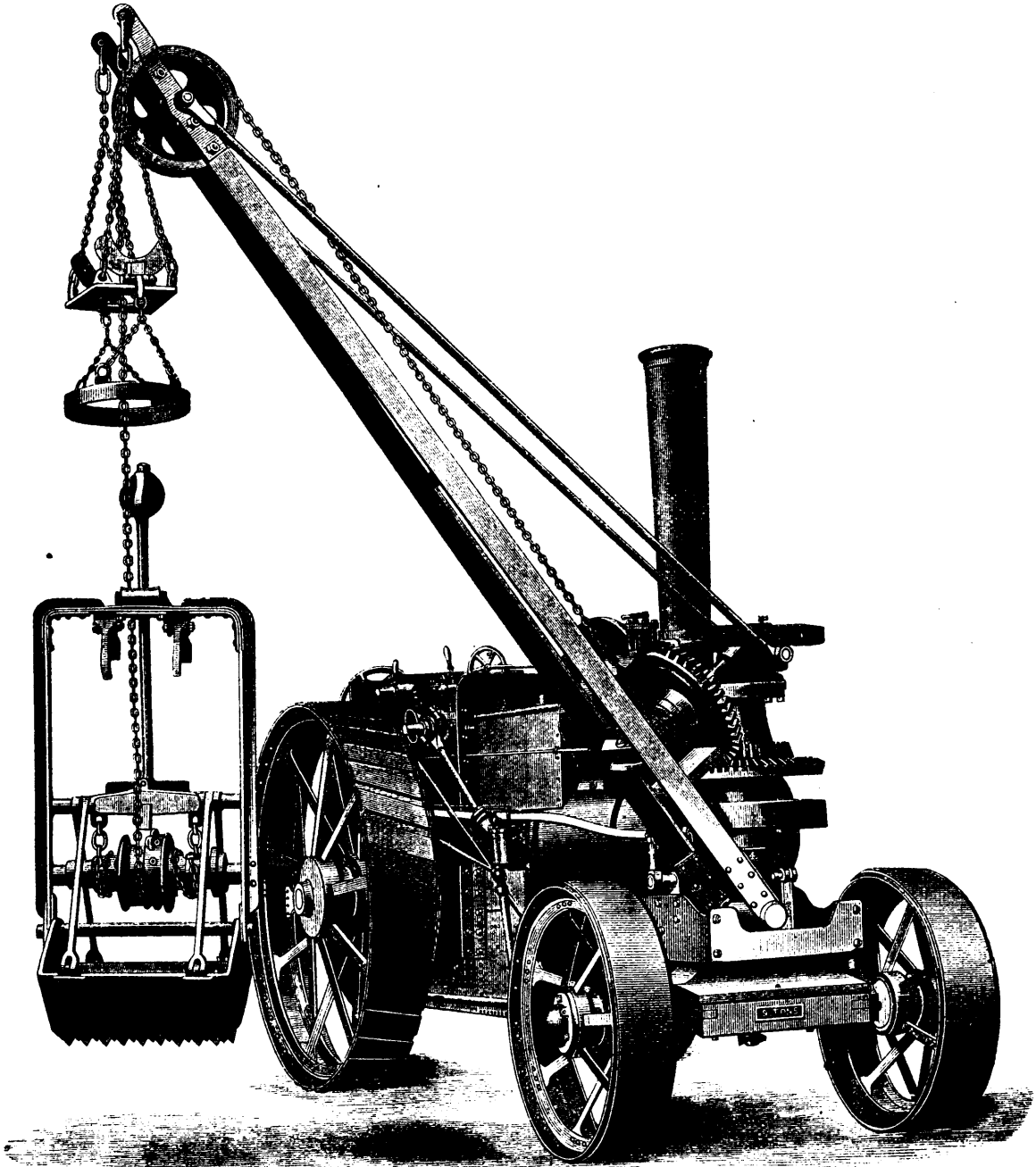

MODERN LOCOMOTIVE CONSTRUCTION.

BY J. G. A. MEYER.

FOURTH PAPER.—TRACTION POWER.

We now come to the consideration of the size of cylinders necessary to turn the driving wheels. Neglecting the friction of the machinery, we may say that the cylinders with a given steam pressure must be large enough to almost slip the wheels; that is, to turn the wheels without advancing on the rails, when the engine is attached to the heaviest train that it was designed to haul. Or, in other words, if a certain amount of weight is placed on the drivers to haul a given train, we must design our cylinders so that a sufficient power can be obtained to turn the wheels, and not more and not less, when the engine is attached to this train. This power which is necessary to turn the driving wheels under the above conditions is called the "tractive power" of a locomotive. If the cylinders are too small in proportion to the weight placed on the drivers, then the engine cannot haul the train that it was intended it should do with this correct weight on the drivers. If, on the other hand, the cylinders are too large in proportion to the weight placed on the drivers, then the engine cannot employ all its tractive power. In either case, there will be a waste of material and steam. Here, then, we see that in a correctly-designed engine there is a fixed relation or proportion between its tractive power and the weight placed upon the drivers. The tractive power is not only dependent upon the diameter of the cylinders, but also depends upon the diameters of the drivers, the length of stroke, and the mean effective steam pressure per square inch of piston.

Before the tractive power of an engine can be calculated, we must know how much of a resisting force is to be overcome. In Fig. 8 we have represented a pair of cylinders and one of the front pair of driving wheels in an eight-wheeled engine, such as shown in Fig. 1. One of the cylinders in Fig. 8 is connected to the driving wheel; the other cylinder is connected to a crank fastened to the same axle, and not connected to a driving wheel, because we have assumed that there is only one driving wheel on the axle. Let us also assume that the cylinders in Fig. 8, with frames, valve gear and all necessary mechanism, are firmly fastened to blocks or a foundation, so that this figure represents a complete stationary engine. The driving wheel is not to touch the track, but the whole engine is set high enough so that a rope can be fastened to the lower part of the driving wheel, in such a manner that when the other end of the rope is attached to a train this rope will be parallel to the track, as shown. When this engine is set in motion in a direction as shown by the arrow, it will haul the train towards the engine. Now, the power that this engine exerts in doing this is precisely the same as the tractive power of a locomotive designed to do the same amount of work. Should the total weight of this train be 1,000 tons, then, according to what has been said before, it will take 7,500 pounds to move it, and therefore, the stress, or the pull on the rope, will be 7,500 pounds.

If instead of fastening this rope to the train, we pass it over a pulley α , and attach a weight W to it, weighing 7,500 pounds, and, as shown on the dotted lines on Fig. 8, then the stress or the pull on the rope will not be changed, but still remain as before, namely, 7,500 pounds, and therefore we conclude that the power necessary to move the train is exactly the same as the power necessary to hoist a given weight.

For the sake of clearness and simplicity, when calculating the tractive power of a locomotive, we shall hereafter always assume that the train resistance is represented by a weight W , fastened by the means of a rope to one driving wheel, as shown in Fig. 8, and that the cylinders must be made large enough to be capable of lifting this weight.

But the reader may say that a locomotive has more work to do than the stationary engine here represented, because the locomotive must move its own weight, which the stationary engine has not to do. This is true, but it must be remembered that we are allowing $7\frac{1}{2}$ pounds for every ton of the weight of train that is to be moved, and, as we have stated before, this may be considered—and we do consider it so—as not only sufficient to move the train, but also sufficient to move the weight of the locomotive and overcome the friction of its mechanism. Yet we must again call the attention of the reader to the fact, that any particular or given speed is not yet taken into consideration; we are simply proportioning an engine capable of moving a train very slowly.

The foregoing being thoroughly understood, the solution of the following example will not seem so difficult:

EXAMPLE 4.—Find the diameters of the cylinders for an eight-wheeled locomotive, whose total weight on drivers is 20,000 pounds, the diameter of the driving wheels is 45 inches, the stroke 20 inches, and the mean effective steam pressure 90 pounds per square inch of piston area. (The writer believes that for the mean effective steam pressure 90 pounds per square inch is a good average, and this will always be adopted unless otherwise stated.)

From what has been said before, we know that the total adhesive force will be one-fifth of the weight placed on the drivers; hence the total adhesive force will be one-fifth of 20,000, which is equal to 4,000 pounds. We have also seen that the adhesion is equal to the train resistance; hence the weight W , in Fig. 8, which represents the train resistance, must weigh 4,000 pounds. Now, all we have to do is to find the diameters of the two cylinders, as shown in Fig. 8, capable of lifting this weight of 4,000 pounds; and so for all locomotives, when the total weight on drivers is known, no matter how many driving wheels are to be placed under an engine, we always assume that the train resistance is represented by the weight W ; that all this weight, or train resistance, is applied to only one driving wheel; and that the two cylinders must be made large enough, so that their combined effort will be capable of lifting this one weight W , which in all cases will be one-fifth of the total weight placed on all the drivers, because we have assumed that the adhesion is one-fifth of the total weight placed on the driving wheels.

In our example, as we have already seen, this weight W is equal to 4,000 pounds, and the diameters of the driving wheels 45 inches each. When the wheel has made one revolution, the weight W will then have been raised through a distance equal to the circumference of the wheel, and this circumference of is 141.37 inches, or 11.78 feet.

In raising this weight, a certain amount of energy must be expended; and to know exactly how much has been expended, we must compare it to some standard or unit of energy.

The small exertion that is required to raise or lift one pound one foot high is called the unit of energy or foot-pound; hence, if two pounds are lifted one foot high, two units of energy have been expended, or if five pounds are lifted one foot high, five units of energy have been expended; and, if the five pounds are raised five feet high, then 25 units of energy have been expended; because, to raise the five pounds through the first foot, five units of energy will be required; to raise them through the second foot another five units will be required; the same for the third and so on up to the fifth, making a total of 25 units of energy or foot-pounds.

In our example a weight of 4,000 pounds must be raised 11.781 feet high. To raise this weight through the first foot, 4,000 units of energy or four pounds will be required, to raise it through the second foot, and again the same through the third foot, so on until the height of 11.781 feet has been reached; therefore, the total number of units of energy, or foot-pounds, that must be expended to raise this weight through a distance of 11.781 feet is $4,000 \times 11.781 = 47,124$ foot-pounds. And so for all engines we multiply the weight, W , in pounds, which represents the adhesion, by the circumference of the wheel in feet, and product will be the number of foot-pounds or units of energy that must be expended during the time the wheel makes one revolution.

But the energy necessary to raise this weight is derived from the steam pressure in the cylinder, and since the mean effective steam pressure per square inch of piston is already given—namely, 90 pounds—it only remains to make the cylinder of such a diameter that we can obtain 47,124 units of energy for every turn of the wheel with a weight attached, as shown in Fig. 8.

But now notice the fact that during the time the wheel makes one turn, raising the weight 11,781 feet high, the piston travels through a distance equal to twice the length of the stroke being 20 inches, the piston travels through a distance of 40 inches, or 3.33 feet. During the time that the piston travels through a distance of 3.33 feet, 47,124 units of energy or foot-pounds must be expended, and therefore, dividing 47,124 by 3.33

$\frac{47,124}{3.33} = 14,151$ foot-pounds.

feet, we have $\frac{47,124}{3.33} = 14,151$ foot-pounds. This last answer

simply means that in order to raise the 4,000 pounds weight through a distance of 11.781 feet the weight being attached to the wheel, as shown, will require as many units of energy as to

raise a weight of 14,151 pounds 3.33 feet high, the weight being attached directly to the end of the piston rod, as shown in Fig. 9.

Now, it must be readily understood that the mean effective steam pressure on each square inch of piston will lift a portion of this weight of 14,151 pounds, and the amount that the pressure per square inch of piston will lift is 90 pounds, hence, di-

viding 14,151 pounds by 90 pounds, we have $\frac{14,151}{90} = 157.2$

square inches. This means that the total piston area must be 157.2 square inches. But we have two cylinders; therefore

$\frac{157.2}{2} = 78.6$ square inches in the area of one piston; and a

piston having an area of 78.6 square inches, must be 10 inches diameter. Hence a locomotive having four driving wheels, with 20,000 pounds placed upon them, the driving wheels being 45 inches in diameter, and a mean effective steam pressure of 90 pounds per square inch, will require cylinders 10 inches in diameter and 20 inches stroke.

Here we have calculated the diameters of the cylinders suitable for a given weight placed on the drivers. We may reverse the order of calculation, and find the necessary weight that must be placed on the drivers, when the dimensions of cylinders and diameters of driving wheels are given.

EXAMPLE 5.—The diameters of each cylinder is 10 inches; stroke, 20 inches; diameter of driving wheels, 45 inches; mean effective steam pressure, 90 pounds per square inch of piston. What is the tractive power of such an engine? And how much weight must be placed on the drivers?

The area of a piston 10 inches in diameter is 78.54 square inches. Multiplying the area of the piston by the steam pressure per square inch, we have $78.54 \times 90 = 7068.6$ pounds total steam pressure on one piston; but there are two pistons, hence $7068.6 \times 2 = 14137.2$ pounds, which is the total steam pressure on both pistons. The stroke is 20 inches, and during the time that the wheel makes one turn, the piston has traveled through twice the length of the stroke, hence $20 \times 2 = 40$ inches, or 3.33 feet, which is the distance through which the piston has traveled during one revolution of the wheel. Multiplying the total steam pressure on the pistons by 3.33 feet, we have $14137.2 \times 3.33 = 47076.876$ foot-pounds, or units of energy the cylinders can exert during one revolution of the wheel. The driving wheels are 45 inches in diameter, hence the circumference of each wheel will be 141.37 inches, or 11.78 feet.

A CURIOUS OPTICAL ILLUSION.

Which is the tallest of the three persons figured in the annexed engraving? If we trust to our eyes, we shall certainly say it is No. 3. But if we take a pair of compasses and measure, we shall find that we have been deceived by an optical illusion. It is No. 1 that is the tallest, and it exceeds No. 3 by about 0.080 inch.

The explanation of the phenomenon is very simple. Placed in the middle of the well calculated vanishing lines, the three silhouettes are not in perspective. Our eye is accustomed to see objects diminish in proportion to their distance, and seeming to see No. 3 rise, concludes therefrom that it is really taller than the figures in the foreground.

The origin of the engraving is no less curious than the engraving itself. It serves as an advertisement for an English soap manufacturer, who prints his name in vanishing perspective between each of the decreasing lines, and places the cut thus formed in a large number of English and American newspapers. The soap merchant completes this curious advertisement by giving a name to the three figures. No. 1 is Lord Churchill, No. 2 is Salisbury, and No. 3 is Gladstone.—*La Nature*.

ROLLED gold is thus manufactured: An ingot of brass is cast and while it is yet hot a thin layer of gold alloy is poured upon it. When the ingot thus covered becomes cold it is forced between steel rollers until a long thin ribbon is produced, of which the proportion of gold and brass is, of course, the same as that of the ingot. The percentage of gold is often reduced very low—sometimes to two and three per cent. This rolled gold in cheap bracelets and watch chains lasts for ten years.

HOW SMOKE IS FORMED.

The following are the views of a correspondent in the London *Iron* on this subject.

"It is well known to every one that when fresh coals are placed on a fire in an open fire-grate, smoke arises immediately and the cause of this smoke is not very far to seek, as it will be easily understood that before the fresh coals were put upon the fire within the grate, the glowing coals radiated their heat and warmed the air above, and thereby enabled the rising gases at once to combine with the warmed air to produce combustion; but when the fresh coals are placed upon the fire they absorb the heat and the air above remains cold.

"By gases, I mean the gases arising from coals while on or near a fire; and it may not be known to every one that we do not burn coals, oils, tallow or wood, but only the gases arising therefrom. I can make this clear by the lighting of a candle, which will afford all the information required. By lighting the candle fire is set to the wick, which by its warmth melts a small quantity of tallow below; and this melted tallow is directly absorbed by the capillary tubes of the wick, and thereby so very finely and thinly distributed that the burning wick has heat enough to be absorbed by the small quantity of dissolved tallow to form the same into gases, and these gases burning, combined with the oxygen in the atmosphere, give the light of the candle. A similar process is going on in all other materials; but coal contains already about 17 per cent. in weight of gases, which liberate themselves as soon as they get a little warm. The smaller the coal, the more rapidly will the gases be liberated, so that in many cases only part of the gases are consumed.

"To return to the subject, the fact is that the volatile rising gases from the coal cannot combine with the cold air for combustion, still a combination does take place in the following way: The cold air in the act of combination, absorbs a part of the warmth of the rising gases, which they cannot spare, and therefore must condense, so much so that all particles are formed, which aggregate, and are called smoke, and, when collected, produce soot; but so long as these particles and gases are floating they cannot burn or produce combustion, as they are surrounded by a thin film of carbonic acid. It is only when collected and the acid is driven off that they burn rapidly.

"I have now shown that cold air is the cause of smoke, which may be greatly reduced by care. In the open fire-grate the existing fire ought to be drawn to the front of the grate and the fresh coal placed behind or on the back of the fire. The fire in the front will then burn more rapidly, warm the air above, and prepare the rising gases for combustion. In this way smoke is diminished, as the gases from the coals at the back rise much more slowly than when placed upon the fire and the air partly warmed. The same process may be applied to kitcheners, thereby almost entirely preventing smoke after the first lighting. For stoves and boilers, warm air may be produced for the entire combustion of all gases."

Miscellaneous Notes.

—THE Trinity House committee, has, for the past twelve months, been making experiments to decide upon the relative merits of gas and electricity as lighthouse illuminants. It has been found that, for ordinary purposes mineral oil is the most suitable and economical illuminant, while for prominent points, electricity affords the greatest advantages.

SMALL articles, such as clock, drawer, piano tuning and door keys, rings, buckles, spurs, etc., are made of cast iron in sand moulds, exactly as the most massive castings are turned out. Ornamental "steel" articles, such as hair pins, shawl clasps, etc., are made of cast iron. So small are some of these castings that it takes more than one hundred to make a pound, and the sand used must be carefully sifted to find all the results of the day's casting.

THE population of the State of Nevada has dwindled down to 12,000 in consequence of the collapse of the mining interest, and there are scarcely enough inhabitants left to maintain a State government. The saltpetre beds, however, may induce a fresh immigration, and add to the population. The deposits are very favourably situated for working, being in the vicinity of a rich farming country, with an abundant supply of wood and water close at hand.

LOCOMOTIVE CONSTRUCTION.

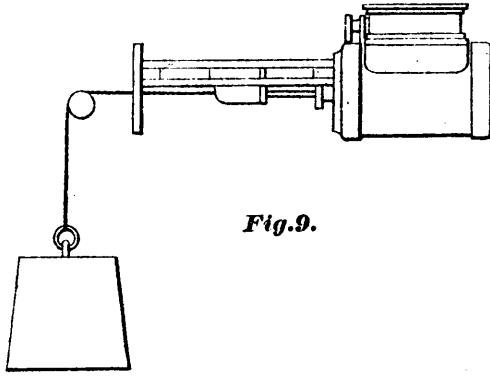

Fig. 9.

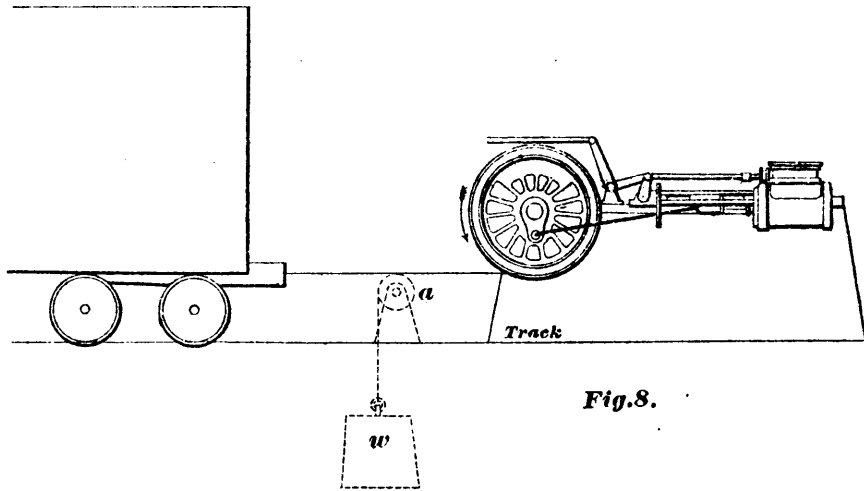
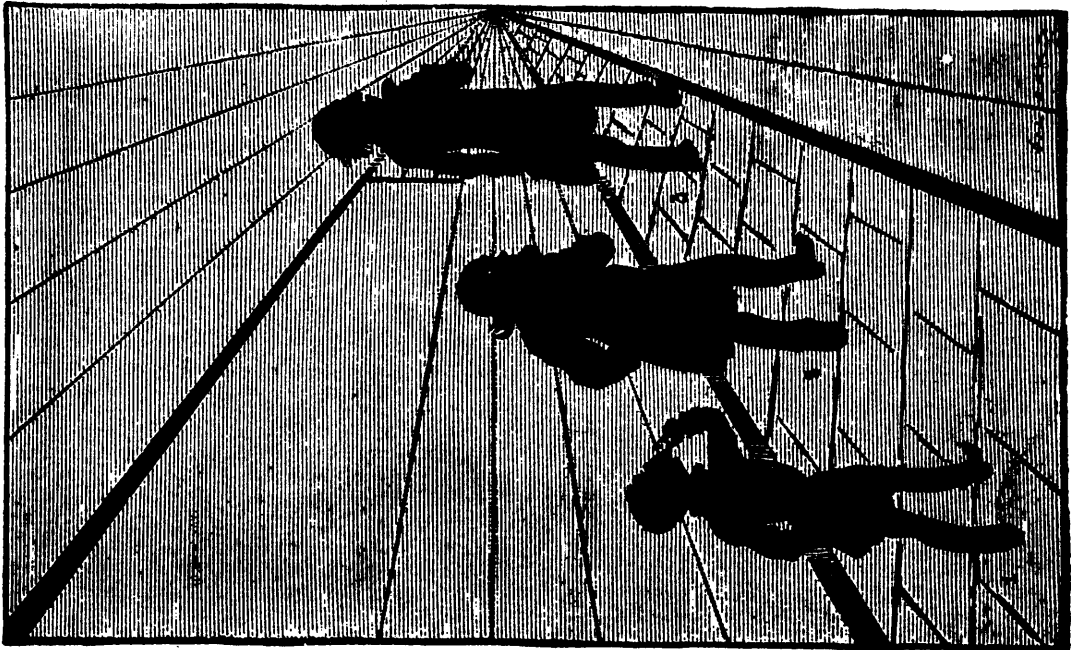

Fig. 8.



AN OPTICAL ILLUSION.