

630
ELEMENTARY
AGRICULTURE
AND NATURE STUDY

—
BRITAIN



NEW BRUNSWICK EDITION

THE EDUCATIONAL BOOK CO., LIMITED
TORONTO

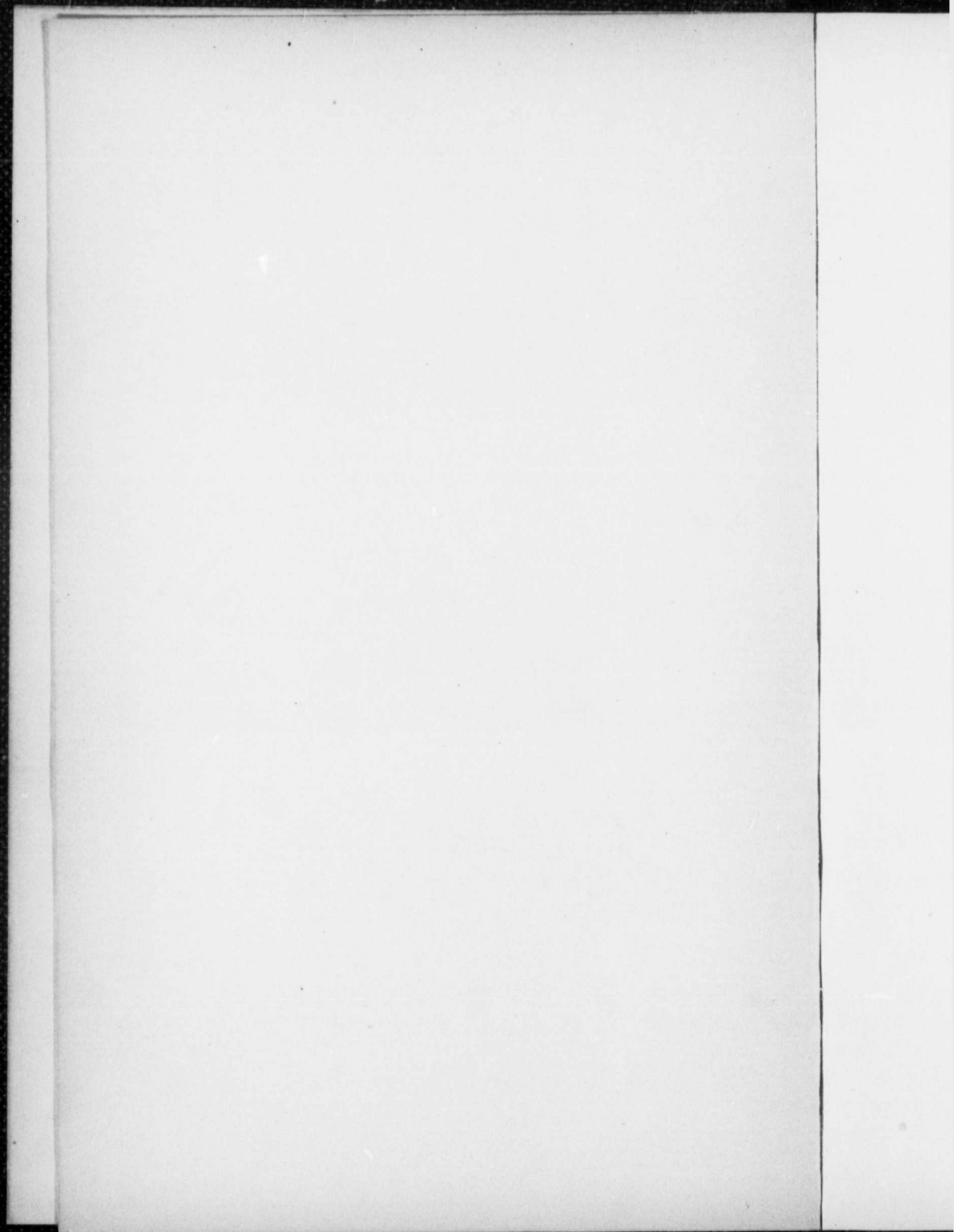

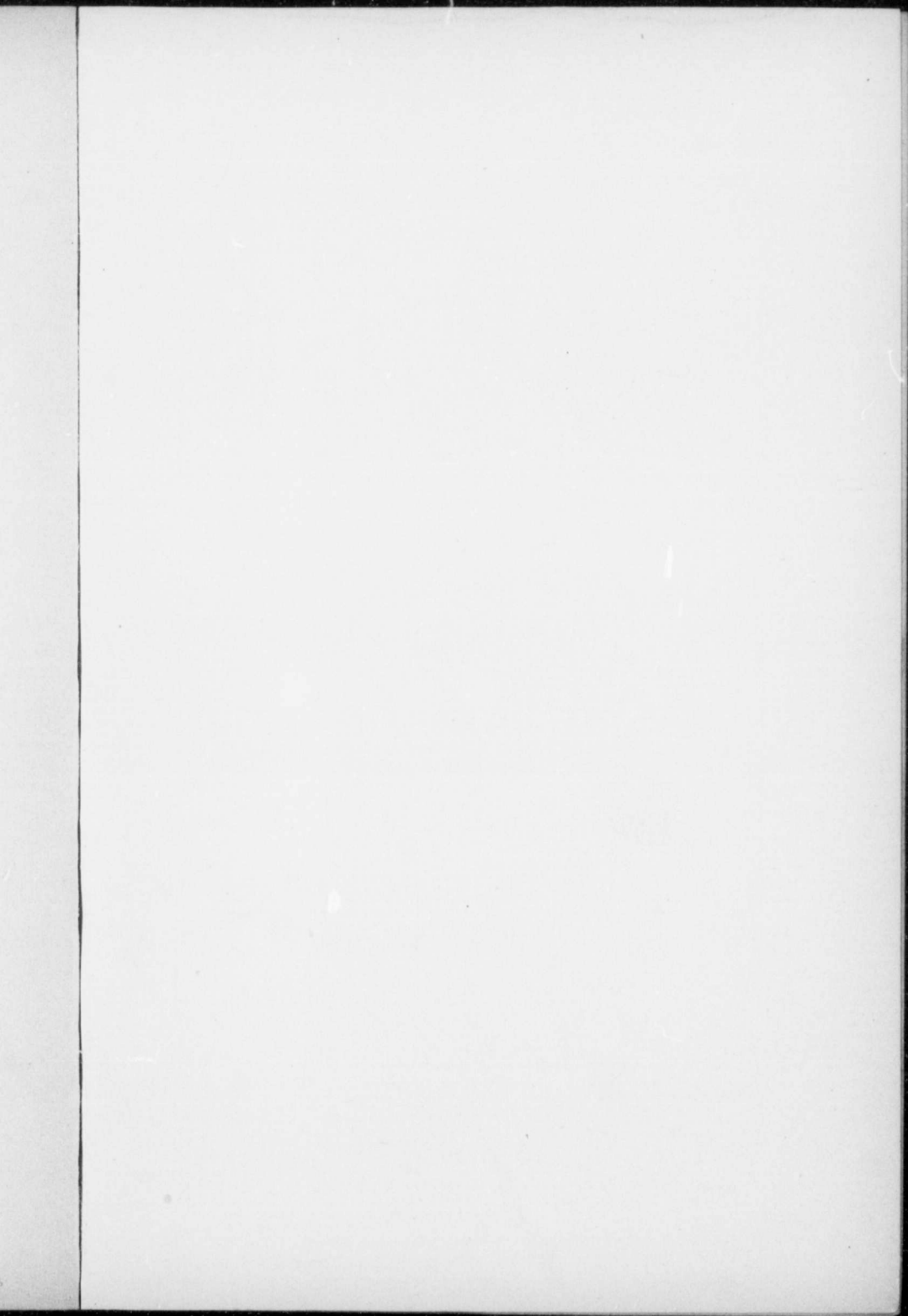

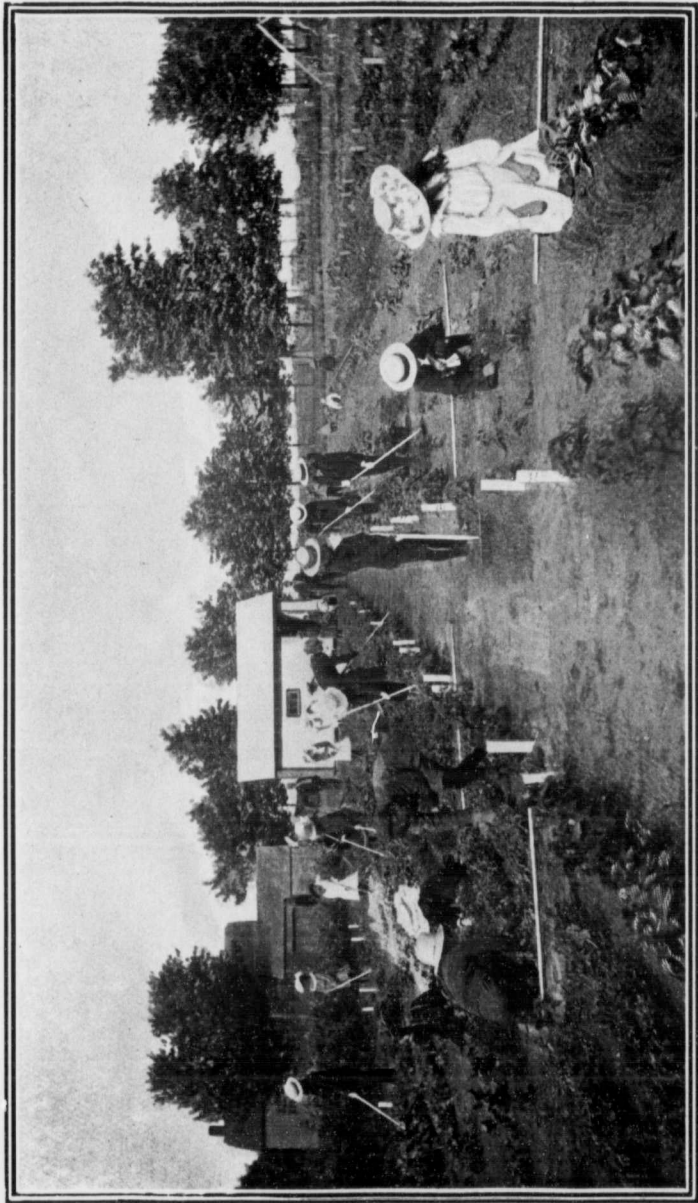

R. B. Whyte, Photo.

A MACDONALD SCHOOL GARDEN.

N
WIT
Co

T

ELEMENTARY
AGRICULTURE
AND
NATURE STUDY

BY
JOHN BRITTAI, D.Sc.

PROFESSOR OF NATURE STUDY, MACDONALD COLLEGE, QUE.

WITH SUPPLEMENTARY CHAPTERS ON "THE PHYSICS OF SOME
COMMON TOOLS" BY CARLETON J. LYNDE, PH.D. ;
"FRUIT - GROWING IN NEW BRUNSWICK" BY
W. W. HUBBARD, SECRETARY FOR AGRICULTURE ;
AND "COMMON WEEDS OF NEW BRUNSWICK"
BY D. WILEY HAMILTON, M.A., PH.D.



THE EDUCATIONAL BOOK CO., LIMITED

TORONTO
437

Entered according to Act of the Parliament of Canada, in the year one thousand nine hundred and nine, by THE EDUCATIONAL BOOK Co., LIMITED, Toronto, at the Department of Agriculture.

TE
their
symp
serve
Ev
All e
tiona
end,
Arith
Since
mitte
in sch
not w
or we
We
and t
sustai
study
and in
centra
either
buildi
sons a
lead c

INTRODUCTION

THIS volume is written by men who are in love with their work, who are masters of their subjects, who are in sympathy with teachers and children, and who desire to serve them.

Every child begins life helpless, ignorant and selfish. All experiences which help it out of that state are educational in the right direction. Looking to that desirable end, one would hardly choose Reading, Writing and Arithmetic for the foremost places in the course of Study. Since all knowledge begins in wonder, one may be permitted to wonder whether the dullness of some children in school is not usually a symptom of a course of education not wisely arranged, rather than an evidence of sluggish or weak mental faculties.

We are all part of Nature. Our lives—the transient and the eternal, the human and the divine in us—are sustained by natural processes under natural laws. A study of Nature lies at the beginning of all true education; and in the elementary classes Nature Study might well be central, with Household Science and Manual Training on either side of it. These furnish a fine framework for the building of character through education. Subjects, lessons and exercises are worthy of place as they serve to lead out the powers of body, mind and spirit towards

ability, intelligence and goodwill in such a way that these will seek and find expression through co-operation with others for the common good. The methods of instruction which guide children to acquire knowledge from the study of Nature usually influence them to pursue studies in Science, Literature and History. Meanwhile they are being trained to think, to observe, to investigate and to understand. The doing of something definite with their new knowledge, under educational supervision, becomes a means towards the formation of good mental habits. In this volume the lessons have been arranged with the difficulties graduated to suit the growing capacity, strength and intelligence of the learners. Progress may be discerned by an increase in the quickness of perception, by an improvement of the memory for names, facts and rules, and still more by the habits of thoroughness, truthfulness and self-reliance which are revealed by the work done.

Nature Study deals with facts and principles on which the systematic study of Agriculture should be founded. It does for Agriculture what Manual Training does for technical and industrial education. It furnishes a wide basis of general intelligence and ability from which to specialize towards particular occupations. The lessons on *The Physics of Some Common Tools* are a fitting sequel to those on *Nature Study*.

Because all school training in observing, investigating and recording should include lessons in reading, writing,

draw
volu
sort.
corre
child
love
good
W
child
gener
"Of

M

drawing and arithmetic, the exercises prescribed in this volume become lessons in expression of a highly valuable sort. They nourish growth of thought, and also clear and correct expression of thought. They minister to the children in developing intelligence, personal ability and love of working with others to attain some end for the good of all.

We all are trustees of life and its opportunities for the children. The main thing in the trust is to have the next generation of trustees ready for their duty and privilege. "Of such is the Kingdom of Heaven."

To love to live is well,
To live to love is better,
And this the best of all,—
To love to live to labor.

JAS. W. ROBERTSON.

MACDONALD COLLEGE,
QUEBEC.

CONTENTS

FIRST YEAR

AUTUMN LESSONS

	PAGE
I. GERMINATION AND EARLY GROWTH OF PLANTS	9
II. THE ORGANS OF VEGETATION	12
III. ORGANS OF VEGETATION (<i>continued</i>)	14
IV. THE ORGANS OF REPRODUCTION IN FLOWERING PLANTS	18
V. ORGANS OF REPRODUCTION (<i>continued</i>)	21
VI. INSECTS AND THEIR RELATION TO PLANT LIFE	25
VII. HOW TREES AND SHRUBS PREPARE FOR WINTER AND SPRING	29
VIII. OTHER SEASONAL CHANGES IN AUTUMN	33
IX. SOME IDEAS ABOUT MATTER	36
X. SOMETHING ABOUT WORK AND ENERGY	40

WINTER LESSONS

XI. CONTENTS OF THE POTATO TUBER	44
XII. THE CONTENTS OF A CARROT	49
XIII. WHAT WE CAN FIND IN A GRAIN OF WHEAT	52
XIV. THE COMPOSITION OF WOOD, STARCH AND SUGAR— CHEMICAL UNION	54
XV. WHAT BECOMES OF WOOD WHEN IT BURNS	59
XVI. WHAT CARBONIC ACID GAS IS COMPOSED OF— OXIDATION	62
XVII. THE COMPOSITION OF THE AIR	65
XVIII. THE COMPOSITION OF WATER	68
XIX. AMMONIA GAS AND ITS COMPOSITION	71

CONTENTS

vii

	PAGE
XX. WHAT THE GLUTEN OF WHEAT IS COMPOSED OF	73
XXI. VEGETABLE OILS AND ACIDS AND A SALT	75
XXII. TREES IN WINTER	80

SPRING LESSONS

XXIII. THE RETURN OF THE BIRDS	83
XXIV. THE SEED AND THE LITTLE PLANT WITHIN IT	87
XXV. THE SEASONAL CHANGES OF SPRING — SPRING CALENDAR	92
XXVI. THE SCHOOL GARDEN	94
XXVII. THE MAKING AND TRANSFERENCE OF STARCH IN PLANTS	99
XXVIII. WHAT PLANTS MAKE STARCH OUT OF	103
XXIX. THE BREATHING OF PLANTS	109
XXX. THE TRANSPIRATION OF WATER BY PLANTS	112

SECOND YEAR

AUTUMN LESSONS

I. THE CELLULAR STRUCTURE OF PLANTS	115
II. THE COURSE OF THE SAP IN PLANTS	120
III. FERNS AND OTHER GREEN FLOWERLESS PLANTS	123
IV. MUSHROOMS	126
V. MOULDS	129
VI. YEASTS	132
VII. BACTERIA AND THEIR WAYS	135

WINTER LESSONS

VIII. THE DOMESTIC ANIMALS OF THE HOME AND FARM	142
IX. THE COMPOSITION AND CARE OF MILK	148
X. A LESSON ON LIMESTONE	153

	PAGE
XI. THE SOLID CONSTITUENTS OF THE SOIL	159
XII. AIR AND WATER IN THE SOIL	164

SPRING LESSONS

XIII. THE PROPAGATION OF PLANTS FROM BUDS	167
XIV. IMPROVEMENT OF CULTIVATED PLANTS	174
XV. A LESSON ON TILLAGE	177
XVI. ROTATION OF CROPS	179
XVII. HOME AND SCHOOL GROUNDS	181

THE PHYSICS OF SOME COMMON TOOLS	185
FRUIT-GROWING IN NEW BRUNSWICK	245
COMMON WEEDS OF NEW BRUNSWICK	281

T
R. 1
Mac
tion
T
throu
York
The
of C
Book

ACKNOWLEDGMENT

THE Publishers are indebted to the kindness of R. B. Whyte, Esq., Ottawa, for the photograph of "A Macdonald School Garden," and to the C. P. R. Colonization Department for the photograph "Happy on the Range."

The colored plate, "The Mourning-Cloak," is reproduced through the courtesy of Messrs. D. Appleton & Co., New York, from "How to Know the Butterflies"—*Comstock*. The colored plate of Birds is reproduced from "Birds of Canada"—*Nuttall*, by kind permission of The Musson Book Co., Limited, Toronto.

I. GL

Ma
for th
a few
a suff
pieces
exper

W
lesso
thing
day
with
bette
ways
and
do, t
own

W
there
them
they
eye,
of th

FIRST YEAR

AUTUMN LESSONS

I. GERMINATION AND EARLY GROWTH OF PLANTS

Material to be prepared in advance.—A supply of seeds for the class, some of this year, some of the year preceding; a few potato tubers; two or three flower-pots filled with soil; a sufficient number of plates and saucers, and of circular pieces of porous paper or of flannel for the germination experiments.

WE are about to begin to-day a course of lessons on plants. We will try to find out something about their lives by watching them from day to day, and by trying various experiments with them. I am sure you will learn to like them better as you become better acquainted with their ways of life, and see that they—like ourselves, and every living thing—have their own work to do, their own difficulties to overcome, and their own enemies to avoid.

We will find, too, in our studies of plants, that there is a vast number of kinds or *species* of them, of all forms and sizes, some so minute that they are far too small to be seen with the naked eye, and some so large (such as the great trees of the forest) that we seldom speak or think of

them as plants. You have noticed, probably, that some plants never bear flowers, no matter how long they live, and that these flowerless plants do not bear seeds. Since most of our conspicuous and useful plants bear flowers and grow from seeds, we will begin our studies with the *flowering plants*—plants which may be grown from seed.

To begin with, I must ask you to get together the seeds of a number of common plants—beans, corn, wheat, peas, clover, etc., including some tree seeds. Get some seeds which were ripened this year, as well as some left over from last year. They all look dry and lifeless, yet no doubt most of them are capable of wakening to life; they are merely dormant, asleep as it were, only to be roused into activity by those influences from outside of themselves which have this power over them. Last year's seeds look no more like waking into active life and growth (*germinating*) than those of this year, nor is there any probability that the mere lapse of time will arouse them, nor will warmth and sunshine alone set them free from the thrall which binds them, for some of them have passed through both a spring and a summer. When seeds are planted by the farmer or gardener in spring, they are also supplied with soil and water.

Let us try an experiment by which we may learn what agencies stimulate the dormant seed

into
sauc
circu
cloth
of e
putt
sepa
with
to p
a fev
again
a wa
day t
Al
not u
or "
inter
the p
this a
soil,
warm

1. V
the tu
2. I
last ye
3. V
second
4. V
the lit

into visible action. Take several flower-pot saucers or table plates and place on each two circular pieces of porous paper or loose woollen cloths, soaked in water. Scatter a number of seeds of each kind between the wet cloths or papers, putting last year's seeds and those of this year in separate plates or saucers; and cover the dishes with others inverted over them. It would be well to place the cloths or papers in boiling water for a few minutes before using them, as a preventive against the growth of moulds. Set the dishes in a warm place, and take a look at the seeds every day to see whether they are sprouting.

Although the potato is a flowering plant, it is not usually grown from seeds, but from the tubers or "potatoes," as they are called. It will be interesting for you to try, at this time, whether the potato tuber of this year can be got to grow this autumn; so plant two or three tubers in good soil, in flower-pots or in a box, and keep them warm and moist.

EXERCISES

1. What percentage of the different kinds of seeds and of the tubers sprouted?
2. How did the seeds of this year compare with those of last year in germinating power?
3. Which of the several kinds of seeds germinated first, second, third, and so on?
4. What parts—*organs* you may call them—may be seen in the little plants when they first emerge from the seed-case?

5. Note whether the young plants grow at one end or at both ends, and what new parts appear as they continue to grow; especially notice the delicate little organs—finer than the finest rootlets—which form on the roots, and observe whether they are produced all the way out to the tip of the root or rootlets. These are the root-hairs. What is their color? Are they branched or simple?

6. Keep the young plants supplied with water for some time longer, to find out how long they will grow without soil, and what new parts will appear.

II. THE ORGANS OF VEGETATION

Material.—The dishes used in the preceding lesson, with the young plants therein; fresh green leaves—some thick and tough, some soft and tender; small saucers or nappies for holding alcohol; test tubes and spirit lamps (or, instead, enamelled cups and a stove).

We will now examine the leaf to learn something of its structure and of the materials which make it up. By scraping the upper side of the leaf carefully with a sharp knife-blade, you will be able to raise a little piece of the *skin*; then scrape through to the lower side, and find the skin there. Decide whether the whole leaf is covered above and below by this thin skin, whether the skin is colored, and whether it will allow light to pass through it. By holding between you and the window a leaf which has been scraped through in places to the upper skin, you will find whether the skin is transparent. Of

cour
non
ente
T
scrap
com
britt
it c
diffe
wood
Bo
the
lowe
mate
ness.
sque
juicy
Bo
chan
and
unbc
(a m
and
chan
appa
alcol
color
extra
will

course unless the light can pass through the skin, none of the sunlight which falls upon the leaf can enter its interior.

Take out one of the larger veins of the leaf, scrape it clean, and note the color of the material composing it; find whether it is more or less brittle than the material around it, and whether it can be split lengthwise. This material, so different from the rest of the leaf, may be called *woody fibre*.

Between the veins, occupying the space between the skin on the upper side and the skin on the lower side, there must be some other kind of material, which gives the leaf most of its thickness. Examine this material by rubbing and squeezing the leaf between your fingers. This juicy part of the leaf may be called the *pulp*.

Boil a fresh green leaf in water, and note the change, if any, in the apparent color of the water and of the leaf. Place the boiled leaf and an unboiled one in hot alcohol or methylated spirits (a mixture of ordinary alcohol and methyl alcohol) and leave them there until you observe a decided change in the color of the leaves, and in the apparent color of the alcohol. In heating the alcohol, be careful not to set it on fire. The green coloring matter which you have wholly or partly extracted from the leaf is called *leaf-green*. You will find out its use later.

EXERCISES

1. How does the pulp evidently differ in its properties and constituents from the skin and the veins?
2. In which of these three materials—skin, woody tissue and pulp—is most of the juice contained? most of the leaf-green?
3. Find what liquid the juice mostly consists of.
4. Press a *small* bit of blue litmus paper into the juice of a leaf. Describe and explain the effect.
5. Which of the three kinds of material found in the blade of the leaf is most abundant in the foot-stalk (leaf-stalk)?
6. Make a collection of leaves which have been partially eaten by insects. Try to find some in which the pulp alone has been eaten by a leaf-mining caterpillar, living and working between the skin on the upper side of the blade and the skin on the lower side.
7. Collect a number of different caterpillars, and place each of them in a wide-mouthed bottle with a little sand or loose soil in the bottom. Keep them supplied with fresh leaves from their food-plant, and watch their behavior till sleep overtakes them.
8. Make drawings of the leaves of some common trees.

III. ORGANS OF VEGETATION (*continued*)

Material.—A collection of cuttings from various stems and roots, including enough pieces of sunflower stalks and corn-stalks to supply the whole class.

We will to-day examine some stems or branches of stems, large and small, soft and hard, to find whether they are made up of the same or of different kinds of material from the leaf. At the

sam
ster
the
leng
as y
mate
pose
Y
bran
as le
thin
pear
It
and
arou
the
leng
expl
T
of m
it is
toug
in m
outs
bark
pith
outs
exog
bark

same time we will compare the structure of the stem with that of the root. You will need to cut the stems off crosswise, and then split the pieces lengthwise several times, testing in various ways as you proceed, to determine the several different materials of which the stems and roots are composed.

You will find whether stems and roots and their branches are ever protected merely by a thin skin as leaves are, and whether they always retain this thin skin; and when, or in what cases, it disappears, and what structure takes its place.

It will soon appear that the parts of the stem and of the root are arranged circularly or radially around the central part, and that for some reason, the stem, whether large or small, is easily split lengthwise, but cannot be split crosswise. Try to explain this circumstance.

The soft substance which you find in the middle of most stems is easily torn apart in any direction; it is called the *pith*. The comparatively hard, tough, fibrous material which surrounds the pith in many stems is called *wood*. The softer material outside of the wood in these stems is called the *bark*. In this class of stems, then, we have the pith in the centre, wood next, and bark on the outside. Stems which grow in this way are called *exogenous* stems. You will be able to find in the bark of some stems long, tough, slender fibres,

somewhat like the fibres of wood; this material is called *bast*. On the outside of the birch stem is a tough layer of *cork*; this corky layer is the part of the birch bark which is peeled off to make canoes, so you see it must keep out water well. You will be able to find a thinner corky layer in the bark of many stems.

In examining the stem (or stalk) of Indian corn quite a different arrangement of the material appears. Compare it with the stem of a sunflower. They both contain a large amount of pith; but in the stem of the sunflower the wood is in a single layer around the pith and inside the bark, which may be readily peeled off. In the corn-stalk you can see many bundles of fibres running through the pith, whereas in the sunflower stalk these woody bundles are absent. Take some of the woody strings out of the corn-stalk with a knife or needle. On the outside of the corn-stalk there is no true bark at all. The outside is hard, made up of woody fibres, dry and packed closely together. This protecting woody exterior does not peel off smoothly like bark does. Stems whose structure is like that of Indian corn are called *endogenous* stems.

EXERCISES

1. Arrange the stems you have been using into two lots, putting all the exogenous stems with the sunflower-stalk and the endogenous ones with the corn-stalk.

2.
the ba
3.
your t
stem y
pressu
of the
of. W
cylinde
or end
4.
wood i
up of s
5.
than o
6.
section
the wo
really
across.
real fo
7.
whethe
that of
8. I
bulk ar
9.
portant
of the l
10. C
more yo
decay, I
11. (I
sunflow
amount
2

2. Mention some stems which show by their color that the bark contains leaf-green.

3. When you squeeze the stem of a red clover between your thumb and forefinger a stiff, hollow cylinder inside the stem yields to the pressure and flattens out, but when the pressure is removed it springs back again. Scrape off the bark of the clover-stalk and find what this hollow cylinder is made of. What sort of material do you find inside this hollow cylinder? Point out whether the clover-stalk is exogenous or endogenous.

4. Find a stem which contains but one ring or layer of wood inside the bark, and another in which the wood is made up of several layers. Account for this difference.

5. Mention several plants whose stems never have more than one layer of wood inside the bark. Why is this?

6. Find a stem which shows, when you make a cross-section of it, radiating lines extending from the pith through the wood. These are called the *pith rays*. They are not really lines, but merely appear as lines when they are cut across. If you could take one out, what would you find its real form to be?

7. Examine the stalks of the common grains, and find whether their structure is like that of the sunflower-stalk or that of the corn-stalk.

8. Show which have more surface in proportion to the bulk and weight of material in them—leaves or stems.

9. Argue that the leaves of plants must be of some important use to the plant, and point out some uses of the root, of the bark and of the wood.

10. Gather in a damp place some old fallen leaves, one or more years old, and find what part of the leaf is the first to decay, and what part remains to the last.

11. (a) Make a drawing of a cross-section of a stem of a sunflower, showing the pith, wood and bark, and the relative amount of each.

(b) Make a similar drawing of a stem which contains several rings or layers of wood. Account for the number of layers.

(c) Draw a cross-section of a corn-stalk, showing its structure.

IV. THE ORGANS OF REPRODUCTION IN FLOWERING PLANTS

Material.—A set of flowers for each student, illustrating common variations in floral structure. Needles stuck through small corks for handles will be found very useful in examining flowers.

You have all observed that after a seed-plant—a plant which produces seed—has grown (*vegetated*) for a time it produces flowers. I suppose you have examined flowers before and know the names of their parts. As a review, arrange before you a set of flowers showing as many variations of structure as possible; compare them with each other, and find examples of the different parts and structural features mentioned in the following description:—

The lowest or outermost part of a complete flower is called the *calyx*, and is made up of a circle or set of *sepals*, which may be quite separate from each other or may be united at the base into a deep or flat *tube*, and only show separately at the tip where they may be counted.

Insid
of pet
also m
herent

Stan
usually
and th
filamen
the an
Find l
are in
anther
discha
anther
discha

In t
the to
of par
this p
seeds
is call
In the
separa
like in
seeds;
witho
carpel
butter
bearin

Inside the calyx is the *corolla*, which is a circle of *petals*, usually more delicate than sepals, which also may be either separate or more or less coherent into a *corolla-tube*.

Stamens stand inside the corolla. A stamen is usually made up of a slender stalk called a *filament* and the *anther* borne on the filament; but the filament may be very short or absent altogether, the anther being the essential part of the stamen. Find how many little cavities—*anther-cells*—there are in the anther of a stamen. Look for some anthers which have not, and some which have, discharged the fine powder (*pollen*) from the anther-cells. Note where the anther-cells open to discharge pollen.

In the centre of the flower, set on the middle of the top of the flower-stalk, you find a part or set of parts different from the stamens. If you open this part you should find in it one or more young seeds or *ovules*. This central division of the flower is called the *pistil* and its parts are called *carpels*. In the buttercup you will see many carpels quite separate from each other and so small and seed-like in form that people are apt to take them for seeds; but if you succeed in opening one of them without destroying the seed you will find that each carpel *contains* a single buttercup seed. So each buttercup carpel is not a seed but a seed-like *fruit*, bearing within it one seed. In some pistils there

is but one carpel; in other cases the pistil is composed of several carpels, united together by their edges. The number of carpels can usually be told by the number of parts the pistil is divided into at the top, or the number of little chambers or "cells" for seeds in the lower part of the pistil—the *ovary*.

You may have heard that the powdery pollen formed in the anthers of the stamens is necessary to the formation of seeds in the pistil. You can feel the sticky surface at the top of the pistil in the newly-opened flowers you have before you, and you may succeed in seeing grains of pollen sticking to it. In flowers in which the carpels of the pistil are separate, or partly so, each carpel has a sticky surface (*stigma*) at the top, to which the pollen grains adhere. It is a common mistake to think that the pollen grain itself goes down through the pistil and causes the seeds to develop; but the fact is—as can be seen with a microscope—that the pollen grain remains on the stigma, and a long slender tube, called the *pollen tube*, grows out of the little grain of pollen down through the pistil to the undeveloped seed (*ovule*). This tube conveys fertilizing stuff from the pollen grain to the ovule. When this does not happen, no perfect seeds—no seeds that will germinate and produce new plants—are formed in the pistil. The pollen is said to *fertilize* the ovule.

1. 1
five.
2. 1
same
is diff
3. 1
flower
4. 1
or less
like pe
5. 1
calyx-
when
out of
is call
6. V
which
what t
Seek c
the ins
7. C
taking
8. M
parts c

V
Mat
relation
If
older
some

EXERCISES

1. Find a flower whose parts are in sets of five or of twice five.

2. Find a flower in which the number of carpels is the same as the number of sepals, and one in which the number is different.

3. Look for other numerical differences in the parts of a flower.

4. Look for cases in which *like* parts of the flower are more or less united, either at the base or at the top. The union of like parts of the flower is called *cohesion*.

5. Find examples of the union of *unlike* parts, as when the calyx-tube adheres to the ovary or seed-vessel of the pistil, or when the stamens or petals seem to be "inserted on" or grow out of the calyx-tube. The union of unlike parts of a flower is called *adhesion*.

6. Visit flowers in the gardens or fields, and find some which are frequently visited by insects. Discover if you can what the insects get from the flowers and how they get it. Seek out any inducements offered by the flowers by which the insects are attracted to them from a distance.

7. Get for yourself some of the stuff which the insects are taking from the flowers and examine it.

8. Make drawings of several flowers, and of the several parts of a complete flower.

V. ORGANS OF REPRODUCTION (*continued*)

Material.—A set of flowers and fruits, illustrating the relation between the two.

If you will compare some fresh flowers with older ones of the same kind, you will find that some parts of the flower fade and wither, while

the pistil not only remains fresh and healthy, but actually keeps on growing till it is much larger than it was before the petals and stamens began to wither and dry up. After a while the pistil, too, ceases to grow. This enlarged ripened pistil is the *fruit*.

To be exact, however, I must tell you that the pistil does not always form the whole of the fruit. The fruit is the ripened pistil alone, unless some other part of the flower has grown in with the pistil, in which case the other part of the flower which adhered to the pistil and enlarged with it, is included in the fruit.

The carpels of which the pistil was composed may still be counted in the fruit. Sometimes they show on the outside of the fruit and usually in the interior of it.

A great many fruits are small and dry and resemble seeds so much that they are called seeds by gardeners and farmers. Each of these little fruits *contains* a seed enclosed by one carpel or more, but the fruit is sown with the seed inside.

In many fruits the carpels open and discharge the seeds. The pod of a pea is such a fruit. When small it was the pistil of the flower. It is composed of one closed carpel containing a row of seeds. It grew on the top of the flower-stalk with the other parts of the flower around it. Try to find it in a sweet pea blossom.

I n
flower
grow
as or
usual
resem
(and
call th
are le
and c
resem
a pea
leaf v
spread
bearin
leaves
afterv
of the
Sta
pollen
leaves
pea-p
the co
the p
seeds
(scale
and c
apples
bearin

I must remind you here that the parts of a flower may be regarded as forms of leaves. They grow on a branch of the stem (the flower-stalk) as ordinary leaves do. The petals and sepals are usually flat and thin, like leaves; indeed, they resemble leaves so much that if they were green (and the sepals *are* commonly green) we would call them leaves at once. If the sepals and petals are leaves, it seems probable that the stamens and carpels might be, although they bear less resemblance to ordinary leaves (*foliage-leaves*); but a pea-pod—which is a carpel—is green like a leaf when young, and if opened out is thin and spreading like a leaf. So the stamens are *pollen-bearing leaves*, and the carpels are *seed-bearing leaves* which form the pistil of the flower and afterwards form the whole or the essential part of the fruit.

Stamens are *closed* leaves, for they enclose the pollen in the anther-cells. Most carpels are closed leaves also, for they enclose the seed, as in the pea-pod and the apple; but if you can procure the cone of a pine or a spruce, or of any tree or the pine family, you will find that their winged seeds are borne on the open face of the carpels (scales) of the cone, which are not folded together and closed up to form a seed-vessel, as in pods, apples, and so forth. The carpels of these cone-bearing trees are *open* carpels. Sepals and petals

—like the foliage-leaves of trees—are open leaves. No doubt the difference in their situation and form means a difference in their uses (*functions*).

EXERCISES

1. Why are the flowers, fruit and seed called organs of reproduction?
2. Find a fruit which was formed from the pistil of the flower only, and another which includes the whole, or a part, of both pistil and calyx. If the calyx is present as a part of the fruit, you will probably find small lobes or teeth at the top of the fruit, which show the number of sepals. In that case, you may consider that the outer part of the fruit, down to the stalk below, represents the tube of the calyx.
3. Find what parts of the flower are present in an apple, a cherry, a bean pod, a grape, a pear.
4. Mention some so-called seeds which are really fruits. Give proofs.
5. Show whether the tuber of a potato is either a seed or a fruit.
6. Make a small collection of seeds and seed-like fruits which are dispersed by the wind.
7. Make another collection of seeds which are adapted for being carried about unwittingly or unwillingly by animals for dispersal.
8. How does the juicy pulp of many fruits aid in the dispersal of their seeds?
9. Find a plant which blooms during the first year of its life; one which does not bloom the first year but blooms the second year; and one which does not produce flowers till it is more than two years old.

as.
nd
s).

of

he
rt,
of
he
at
vn

le,

ts.

or

ts

or
ls

ne

ts
ne
it

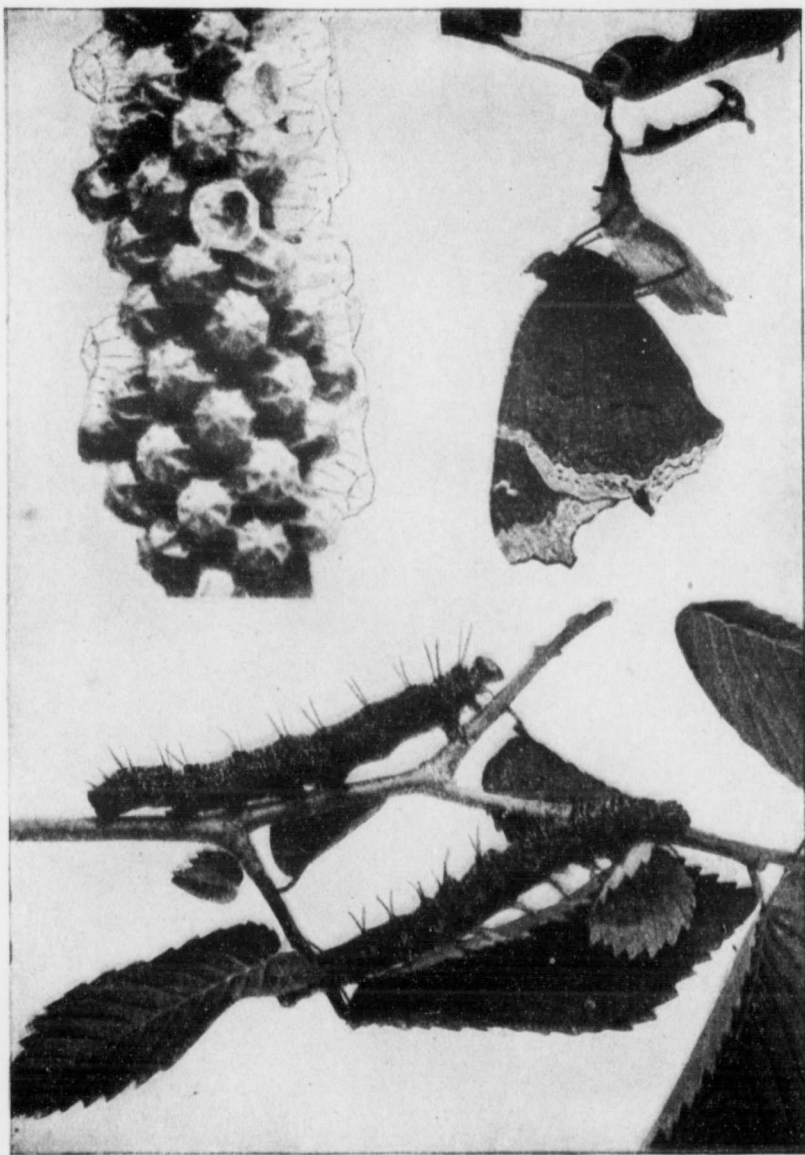

THE MOURNING-CLOAK.

1. Eggs greatly enlarged.

2. Full-grown larvæ.

3. Butterfly just out of the chrysalis skin.

From "How to Know the Butterflies."—COMSTOCK. (Reproduced by permission.)

VI. I

Mat
put up
of inse

I s
appro
and a
insect
and l
and k
kindly
honey
the l
flight.
we w
habits
whose
most
about
uncon

The
and v
first t
includ
larvæ
or ad
speci

VI. INSECTS AND THEIR RELATION TO PLANT LIFE

Material.—A set of specimens—living, dead or dormant—put up in bottles or jars, illustrating stages in the life-history of insects.

I suppose many of you, especially the girls, approach this lesson with an involuntary shudder and a feeling akin to disgust; yet the majority of insects are not only beautiful, but they lead clean and healthy lives. Perhaps of all insects, bees and butterflies commend themselves most to your kindly feelings—the former on account of the honey they produce, and which we enjoy, and the latter by their pretty colors and graceful flight. Out of consideration for your prejudices, we will avoid in this lesson those insects whose habits are uncleanly from our point of view, and whose forms and appearance are objectionable to most people. When you come to know more about insects and their ways I am sure that this uncomfortable feeling will gradually disappear.

The life-history of an insect is a wonderful story and very surprising to one who follows it for the first time. The complete life-history of an insect includes four stages—the egg, the larva (plural larvae), the pupa (plural pupae), and the imago or adult insect. I hope you may have secured specimens of these forms for this lesson. The

eggs, usually about as large as pin-heads, may often be found glued in close clusters to branches or leaves. Caterpillars (larvae), hairy or smooth, may be found feeding on leaves or crawling on the ground. They may be brought in small jars or boxes to the school. Pupae may be sought for suspended from branches, boards, or other supports, or enclosed in cocoons.

The final stage of an insect's life—usually winged—is called the imago. If the imagos of bees or butterflies cannot be obtained for this hour, those of flies will answer the purpose. The complete life-history of an insect may be summarised as follows:—

1. The *egg*. This stage is dormant and motionless and remains so until the next form—the larva—hatches out of it.

2. The *larva*. The larvae of the great groups of insects differ much in appearance, and receive different names. The larvae of butterflies and moths are called *caterpillars*, and may be smooth or hairy. The larvae of flies are called *maggots*; those of beetles are *grubs*. Larvae, no matter how worm-like, should not be called worms, for worms never develop into a higher form as larvae do. In the larval stage the insect is active, crawls about, eats voraciously leaves, fruit, wood, decaying matter, or other insects, according to its taste, and grows so rapidly that it bursts its skin and casts it off (*moults*), sometimes ten times before it attains its full size. When its appetite subsides, the larva may construct around itself a small bag or loose case called a *cocoon*. The cocoon is often composed mainly of its own hair, sometimes of silk drawn from its body, sometimes of

earth
compl
of ma
transf
hard

3.
dorme
pupae
a coc
form-

4.
active
distan
do no
flower
ing fr
happi
ends
its eg
larva.
betwe
the p

In
devo
fores
the s
wood
and
sprea
germ
our
meth
in el

earth or bits of wood stuck together. When the cocoon is completed the larva turns into a pupa. Some larvae, instead of making a cocoon, suspend themselves from a support and transform into a pupa, the outside of their bodies becoming hard and dry, to form a protective case.

3. The *pupa*. In this third stage the insect is usually dormant and inactive. Many insects pass the winter as pupae. As we have seen, the pupa is commonly enclosed in a cocoon, from which at last the insect emerges in its adult form—the *imago*—usually with wings.

4. The *imago*. This is the final form of the insect. It is active and often able to fly with great rapidity, and for long distances. Most insects in this stage eat or drink, but they do not grow. You may often see them flying from flower to flower sipping nectar, and sometimes collecting pollen. Judging from their gay manners one would think that this is the happiest part of the insect's life, but it is the stage which ends in death. Before it dies, however, the insect deposits its eggs on or near the food-plants or food-material of its larva. In some insects, such as grasshoppers, the distinction between the larva and the pupa is not clearly marked, and the pupa is active and similar to the adult in form.

Insects do an immense amount of damage by devouring the leaves of our cultivated plants and forest trees. They often live in fruits, and even in the stems of trees by gnawing passages through the wood. Some species suck the juice out of leaves and tender stems. Mosquitoes and house-flies spread sickness and death by conveying disease germs and depositing them on or in our bodies or our food. Although we have discovered various methods of keeping destructive and noxious insects in check, they still continue to put us to great

trouble and loss. Indeed the damage done throughout the country may be reckoned in millions of dollars every year.

Still we should remember that insects do a great deal of good. They pollinate the flowers of our fruit trees and vegetables, thus insuring the production of seed. Some kinds act as scavengers, devouring foul and decaying matter; others—the lady-beetles for instance—benefit us by devouring the insects which feed upon our crops. The “little busy bee” is our unconscious benefactor, since we regularly rob it of its stores of honey.

EXERCISES

1. Collect some caterpillars and put them with leaves from their food-plants, in fruit jars, wide-mouthed bottles or boxes with the front made of glass and the back of wire netting. If you use jars, the mouths may be covered with thin cotton cloth fastened on with a rubber band or a string. Put an inch or two of sand or loose earth in the bottom of the jars or boxes. Supply the caterpillars with fresh leaves until they begin to prepare to pupate (turn into pupae). If you get an opportunity, watch the process of cocoon-making.

2. After the caterpillars have transformed into pupae, set the jars or boxes away in a cool place, to await the coming of spring.

3. Examine the external structure of an insect in the imago state. Note the three principal divisions of its body, and that these divisions are made up of short joints or segments. Count its wings, legs, feelers and eyes.

4. Find an insect which bites off and chews its food, and another which does not chew, but *sucks* the juice of plants. Watch the processes of chewing and sucking.

5. Make a sketch from life of an adult insect with wings.

VII.

Mate
trees, i

How
branch

They

on cal

turbs

break

still e

place t

the fo

anywh

across

for if

would

trees a

to get

should

the tre

work c

them t

Look

when t

Compa

What

scars c

VII. HOW TREES AND SHRUBS PREPARE FOR WINTER AND SPRING

Material.—A set of branches from different species of trees, including some fruit trees.

How easily the leaves break off from the branches and shrubs at this season of the year. They may be seen fluttering down to the ground on calm days when not the slightest breeze disturbs them. Their own weight is sufficient to break them off. Carefully pull off some leaves still clinging to the branch, and find at what place the foot-stalk (leaf-stalk) breaks. Then test the foot-stalk to see whether it is as easily broken anywhere else. It is evident that this brittle layer across the foot-stalk must form in the autumn, for if it had been present in summer the leaves would all have fallen off then. So most of our trees and shrubs act as if they deliberately planned to get rid of their leaves in the autumn. Why should they? It must be of some advantage to the trees to be leafless in winter. Whatever the work of leaves may be, it must be impossible for them to continue it during the cold season.

Look for the marks left by last year's leaves when they fell. These marks are called *leaf-scars*. Compare them with the leaf-scars of this year. What do you find close above the leaves or leaf-scars of this year? These little knobs are the

winter buds; but there are no buds above last year's leaf-scars in most cases. Instead, there is usually a branch. Since this year's leaves have buds above them, it is clear that last year's leaves had buds above them last autumn. But these buds of last year have since grown out into branches. It seems then that each *side-bud* develops, not into a leaf as some imagine, but into a whole branch bearing several leaves. After the leaves have fallen, the number of leaves on a branch which came from one bud can be found by counting the leaf-scars. It will be interesting to dissect one of the larger buds with a needle to see whether its structure affords any proof that the bud would become a branch bearing a number of leaves.

Covering the delicate parts of the bud within, you often find dry scales overlapping each other, whose use is evidently to protect the undeveloped branch. These *bud-scales* may be regarded as another form of leaves, for they grow on the same stem upon which the foliage-leaves grew, and are more or less leaf-like in form. When the bud-scales fall off in spring, they leave little curved scars to mark their places. These sets of bud-scale scars mark the place of last year's buds; and perhaps the buds of earlier years may be located by their means.

Let me next call your attention to the *end-buds*

(term
branc
side-l
soon
be al
and c
found
you s
in len
you c
length
Find
most

The
called
branc
leaves
flower
bearin
How
to kn
and s
the w

As
cover
start
spring
up fo
the d

(terminal buds) which you find at the top of the branches and branchlets which have grown from side-buds. By studying your branches you will soon find the use of these terminal buds, and will be able to locate the terminal bud of last year and of several preceding years. When you have found the position of last year's terminal bud, you see at once how much the branch increased in length since last winter; and in many branches you can find how much the branch extended its length during each of several preceding years. Find in which of these years the branch grew most rapidly.

The buds which we have been discussing are called *leaf-buds*. Each of them develops into a branch (or a continuation of one) bearing foliage-leaves. In addition to the leaf-buds, trees prepare *flower-buds* which develop into short branches bearing flowers. Find some of these flower-buds. How strange it is that the trees and shrubs seem to know that winter is approaching with frost and snow, and that the genial spring is to succeed the winter!

As each tree prepares miniature branches and covers them with waterproof bud-scales, ready to start into activity and growth as soon as the spring sun arouses them, so, too, the tree stores up food in the branch near the buds to nourish the developing buds during their early growth.

There is a notion that the scales which cover buds keep them warm in winter. It is impossible that such thin coverings could be very effective in that way during our severe winters. It seems that the chief use of the scales is to keep the buds from drying up during the dormant season. Find the use of the resinous substances which sometimes stick bud-scales together.

EXERCISES

1. Compare leaves that have fallen from the trees with some fresh leaves from other plants. What differences do you observe?
2. Find whether stems which die before winter comes—that is annual stems—have any buds; and if you find such buds, compare them with those of plants whose stems live through the winter.
3. Try whether you could tell the different trees and shrubs apart by the shapes of their leaves, and, after the leaves have fallen, by their leaf-scars and buds. Make a collection of leaves and twigs from the common trees.
4. Make a drawing of a short branch, showing the buds and leaf-scars.
5. Look for examples of other plants besides trees and shrubs, which make preparations for spring by storing up food or in other ways.
6. What relation can you discover between the arrangement of the leaves and that of the buds and branches?
7. Find, by cutting a branch off in several places, how many rings or layers of wood there are in the segment which grew this year from last year's terminal bud; how many in the part which grew out last year; and in the part which has been growing for three seasons. In the last case, show which is the oldest and which the newest layer.

VII
TY
sist
mete
autu
the l
a qu
perer
grou
stems
as the
part,
about
the w
exam
roots
fleshy
others
which
Ann
year,
the yo
parent
effort
away
when
are reg
stored
3

VIII. OTHER SEASONAL CHANGES IN AUTUMN

The trees and shrubs—plants whose stems persist and continue to increase in height and diameter year after year—make preparations every autumn, as we have seen, in order that they may the better endure the rigors of winter and make a quick start in the spring; but there are many perennial plants whose stems die down to the ground every autumn, and are replaced by new stems with new leaves in the spring. Such plants as these lay up a store of food in the underground part, which, though the soil may be frozen hard about it, remains alive but dormant throughout the winter. Some of these, as the dandelion for example, pack away a supply of food in their roots; some, as the onion, in a close cluster of fleshy leaves called a *bulb*; while the potato and others develop underground stems (*root-stocks*) which they use as storage organs.

Annual plants, such as wheat, which only live one year, store up their food in their seed to nourish the young plants of the next generation. The parent wheat plants, apparently exhausted by the effort to provide for their offspring, then wither away and die outright early in the autumn. So when we eat onions, potatoes or wheat bread, we are regaling ourselves on the food which the plants stored up for themselves or for their successors.

The great majority of our birds, too, are gifted with some kind of foresight which warns them, often while the days are fine and warm, that a season which they have never seen is approaching, when it would be difficult or impossible for them to keep warm and find enough food to sustain them. Gradually, we know not the day or the hour, such species depart for the sunny south.

If you are fortunate enough to be lovers of birds and bird songs you will feel the solitude and silence which slowly takes possession of the fields, groves and forests as the feathered tribes depart and leave no mementoes save their empty nests. Our regret is softened by a certain hope that the birds, having braved all the dangers of the journey, will return in the spring-time in a happier and more tuneful mood.

Many will not have very far to travel, as they only go a few degrees to the south, but others keep on southward until they reach Mexico or Central America, or, crossing the Caribbean Sea, enter South America. The bobolinks are said to cross the equator and stay not in their flight until they reach southern Brazil, thousands of miles from the cosy homes where they first saw the light.

A few of the birds remain with us throughout the year. You will see them sometimes in the

wint
then
your

Th
prep
scarc
hum
hous
on a
worl
like
only
whic
In la
ston
bran
the
cater
great

Th
strea
ence
with

W
throu
days
tion
and
stead

winter, and you may have an opportunity to help them through by throwing them crumbs from your table.

The insect tribes, as well, have learned to prepare for winter. You have all noticed how scarce insects seem to be in the cold season. No hum of bee, no buzzing of mosquitoes in the houses, only an occasional house-fly to be seen on a warm day. This great stillness in the insect world does not mean that the insects have migrated like the birds to a more genial climate. They are only dormant, and their various resting-places in which they pass the winter are not hard to find. In late autumn, hidden away in crevices, or under stones, suspended from boards or rails, glued to branches or leaves, hidden in moss or buried in the earth, usually as eggs, but sometimes in the caterpillar or the winged state, they await the great awakening.

The various wild creatures of field, forest and stream have solved the problem of winter existence in different ways, but each in accordance with its own capabilities and habits.

While all these preparations are being made throughout the animated world, the shortening days, the falling temperature, and even the position in the heavens of the sun, moon, planets and conspicuous constellations mark the slow but steady approach of winter.

EXERCISES

1. Find some plants, cultivated or wild, whose stems die down in the autumn, while their roots, underground stems and buds remain dormant, ready to start in the spring. Find where their food is stored.

2. Examine specimens of garden plants which store up food in their roots before they blossom in the same or the following year.

3. Observe as far as you have opportunity, the order of departure of the common migratory birds.

4. Measure your shadow or that of some fixed object once a month at the same hour of the day until the end of the year. How much does the length of the shadow change in three months' time? Account for this change.

5. Record the length of time from sunrise to sunset once a month during the last four months of the year. Explain the change in the duration of daylight.

6. Record once a week during the same months the outdoor temperature as indicated by the thermometer. Take the temperature always at the same hour of the day. State the amount of variation and explain.

IX. SOME IDEAS ABOUT MATTER

Material.—A pail of water, glass jars or bottles, test tubes or enamelled cups, spirit lamps, a small vial, a tumbler, a little aqua ammoniac (ammonia in water), sugar and salt.

All boys and girls of your age have noticed that some things, such as wood, iron, water, milk, etc., take up room, or in other words, *occupy space*. We apply the term *matter* to anything that will occupy space.

It may never have occurred to you that there are things which are quite invisible to us which occupy space as completely as those forms of matter which we can see. Let us consider the air in what we call an *empty* bottle. Push the open bottle, mouth downward, into a vessel of water. You will find that the water does not enter the open mouth of the bottle and fill the bottle when you push it down beneath the surface of the water. The air occupies space, for it excludes the water from the bottle. If you push the bottle under water and incline it on its side, you can see the bubbles of air coming out of the bottle, and as the air goes out the water rushes in, but not before; so air is a kind of matter.

A portion of matter of sensible size is called a *body*. The amount of space included within the limits of a body is called its *volume*. A body does not necessarily fill all the space included within its limits; for instance, sand and gravel do not. The volumes of bodies are expressed in various units, such as cubic inches, cubic centimeters, gallons and bushels.

The different *kinds* of matter are called *substances*. For example, wood, water and air are substances. A substance such as wood, which is so firm or rigid that it will not flow, is called a *solid*. Substances which will flow readily, like water and air, are called *fluids*. You have noticed

that if you leave some water in a corked bottle, the volume of water remains the same. The water lies in the bottom of the bottle; but if you catch some invisible ammonia in a small vial and set it open in a large bottle, and cork the larger bottle, you will find in a short time, by the smell, that the ammonia has spread throughout the larger bottle. The ammonia does not tend, as the water does, to retain its volume, but tends to increase in volume, and spread throughout all the available space. A fluid such as water, which tends to hold together and retain its volume, is called a *liquid*. Fluids such as ammonia and air, which tend to diffuse through space and become thinner and thinner, are called *gases*.

Many substances may exist either as a solid, a liquid or a gas. Water is one. In the form of ice it is a solid; when the ice melts it is liquid water; as invisible steam it is a gas. The visible water vapor which we see issuing from a boiler or a kettle is not steam. True steam or gaseous water is invisible. If you watch visible vapor forming at the mouth of a kettle, or at the mouth of a test tube in which water is boiling, you will see that the visible vapor is formed from an invisible gas. This invisible gaseous water is the true steam. Leave some water in a tumbler in the room. The water gradually escapes from the tumbler and leaves no trace behind. It has diffused

through
the w
could
chang
gas w
We sa
Put
cup of
of wat
entirel
they c
the sa
They
itself,
from
be *dis*
are ca
other
each s
ing va
vapor.
distille
dissolv
dissolv

1. F
to any
2. Se
corked

through the air; but it was not as a liquid that the water escaped from the tumbler, else you could have seen it going. The liquid water changed into invisible gas (steam), and it was the gas which spread through the air of the room. We say that the water evaporated.

Put about half a teaspoonful of sugar into a cup of water, and as much salt into another cup of water. If the sugar and salt do not disappear entirely in a short time, gradually add water until they do. Although you cannot see the sugar or the salt now, you can taste them in the water. They seem to be in a liquid state, like the water itself, and so cannot be distinguished by sight from the water. The sugar and salt are said to be *dissolved* in the water, and the two mixtures are called *solutions*—one a solution of salt, the other a solution of sugar in water. Boil some of each solution in a test tube, and catch the escaping vapor in a cold bottle. Taste the condensed vapor. The liquid you collect in the bottle is *distilled water*. You now see how to separate a dissolved solid from the liquid in which it was dissolved.

EXERCISES

1. Find several solid substances which will not dissolve to any perceptible extent in water.
2. Set a clear solution of salt and one of sugar aside in a corked bottle, till you have decided whether the salt and the

sugar will become solid again and settle to the bottom of the water. Then leave the bottle open till the water evaporates, and examine the dry residue.

3. Find a solid, other than ice, which will become a liquid when heated, and another solid which cannot be fused (liquefied by heat).

4. Find the volume of a rectangular box 12 in. long, 8 in. wide and 5 in. deep. Explain the process.

5. What volume of sand would the before-mentioned box hold, supposing the box to be made of material $\frac{1}{2}$ inch thick?

6. (a) Give reasons for thinking that air has weight.

(b) What do you think is the cause of weight?

X. SOMETHING ABOUT WORK AND ENERGY

Material.—Spirit lamps, a piece of coarse iron wire, a vulcanite (hard rubber) comb, a piece of woollen cloth, silk thread, balls of dry sunflower pith, small thin pieces of various metals, and light pieces of several other substances, slender sewing needles, small pieces of cork, earthen bowls or saucers filled with water, and a good horse-shoe magnet.

In order to do work we must move some material body, or cause one that is moving to go faster or more slowly, or in a different direction. So you see, you are really working when you are playing, for you are moving things.

Some of you at least have had the experience of working till you felt tired. Now, I think you will admit that when you feel tired you really feel as if you had lost something—that you have less of something than you had before. That which

you
energ
you l
proba
you l
You
energ
or the
ounce
pound
more
for it
when
in a
work,
you l
cold p
This i
one b
piece
becor
Hal
light
threac
will h
near
vigoro
succes
flanne

you lost in consequence of working is called energy. *Energy is the ability to do work*, and you lost some of that ability. However, you will probably get a fresh supply to make up for what you lost.

You must have observed that the amount of energy a body has does not depend on its size or the quantity of matter in it. Apparently an ounce of gunpowder has more energy than a pound of clay. Certainly a hot piece of iron has more energy than the same piece when it is cold, for it can do work when hot which it cannot do when cold. For instance, it would burn a hole in a board. When it is doing that it is doing work, for it is moving the parts of the wood. If you lay a hot piece of iron on a cold piece the cold piece becomes warmer—rises in temperature. This is a case in which energy is transferred from one body to another, for the energy of the hot piece becomes less, while the energy of the other becomes greater.

Hang up balls of dry sunflower pith and some light pieces of metal and other substances by threads of silk. Try whether a hard rubber comb will have any visible effect on them when held near without touching them; then rub the comb vigorously with a piece of flannel and hold it, successively, near the suspended objects. The flannel and comb should be warm and dry in

order to get the best results. You will find the comb will do work after being rubbed that it could not do before—that is, it gained energy while you were rubbing it. You lost muscular energy in rubbing the comb, but of course the comb did not gain muscular energy, for it has no muscles. The energy acquired by the comb is called *electrical energy*.

This experiment illustrates another case of transference of energy; but the energy was transformed as well as transferred.

You will find that a magnet will not act on all substances which the electrified comb acts upon; it has another form of energy—*magnetic energy*.

When you heated the iron you were imparting *heat energy* to it. The iron weighs no more when it is hot than when cold. The heat increases its energy, but not its weight. The comb, too, when electrified, has more energy than before, but you will find that it weighs no more. Matter has weight, but energy has no weight.

EXERCISES

1. Try to electrify other bodies besides the comb.
2. Find by experiment whether electrical energy will pass from one body to another without being transformed.
3. Find what substances are attractable by the magnet, and some which are not.
4. Rub your knife-blade with a magnet, and explain the result.

5. I
several
small
placed
not be
directi
water.
does i
marine

5. Rub a steel needle with one end (*pole*) of the magnet several times in one direction. Stick the needle through a small piece of cork and float it evenly on a dish of water placed in such a position that the action of the needle will not be affected by objects made of iron or steel. Note the direction in which the floating needle comes to rest on the water. Swing it half way around and let it go again. How does it act? You have just made a simple form of the mariner's compass. Point out its use.

WINTER LESSONS

XI. CONTENTS OF THE POTATO TUBER

Material.—Potato tubers for the class, test tubes, spirit lamps, iodine solution (obtainable from a druggist—may be diluted with methylated spirit), thin white cotton cloth (cheese cloth) in square pieces, saucers or glass nappies. If test tubes are not available, the potato juice may be heated and water boiled in enamelled cups.

WE noted in a preceding lesson that the storage of food for future use was a common habit among plants. It is now in order for us to examine some storage organs to find the principal substances they contain. We will begin with the potato tuber, commonly called a "potato."

Before we proceed to search for the principal substances of which a potato tuber is composed, note the arrangement of the buds called the "eyes" of the potato. Cut the tuber in two crosswise, and find the parts corresponding to the pith, wood and bark of an ordinary stem. The lines marking off these three divisions may be seen, but you will find the materials in them very different from those of the corresponding parts in the stem of a tree.

You will notice that the interior of the tuber is quite wet with a watery liquid, which you can

ident
water
litmu
of co
litmu
the j
stanc
chara
cates
Rec
by se
the p
cotton
into
out in
water
time
water
squee
the p
betwe
On
find th
throug
up wi
—soli
into c
and le
to the

identify by its feel, taste and lack of color to be water, at least mostly. Press a piece of blue litmus paper into this watery juice. What change of color do you observe? Try pure water on litmus. The change in color plainly indicates that the juice is not pure water, but has some substance dissolved in it. The change you observed is characteristic of substances called acids, and indicates the presence of an *acid* in the potato juice.

Reduce half of a potato to a fine pulpy mass, by scraping it with a knife or a grater. Place the pulp in the middle of a piece of thin, bleached cotton cloth (cheese cloth). Gather the cloth up into the shape of a bag, and squeeze the juice out into a dish. Use a *little* water—not as much water as juice—and wet the pulp from time to time by pressing the cloth into the juice and water in the dish. By repeated wetting and squeezing you will get nearly everything out of the pulp that will pass through the meshes between the threads of the cloth.

On examining the contents of the dish you will find that some fine white solid material has passed through the cloth along with the water. Stir this up with the water and juice, and empty everything—solid and liquid—that passed through the cloth into one or more test tubes or into a small bottle, and let it stand till the solid substance has settled to the bottom.

Then pour off some of the liquid into a test tube. Heat the liquid—but not to the boiling point—until a solid substance forms in the water, and may be seen mixed with or suspended in the water. Allow it to settle. Why could you not see this solid substance before you heated the water? It must have been dissolved in the cold juice, but became solid when the water was heated. This substance—which is soluble in cold water, but becomes solid in hot water—is called *albumen*. It takes its name from the Latin word *albus*, which means white. If the solidified potato albumen is not quite white, it is because it is not pure.

Next turn your attention to the substance which settled to the bottom of the watery juice at first. Pour the liquid off. Though this sediment is white, it is not albumen, for it was not dissolved in the juice of the potato. How could it pass through the cloth in the solid state? Try to find this out by examining the sediment. This white substance is called starch. You can tell by the amount you obtained whether it forms a large part of the tuber or not.

Mix a *little* of the starch with an inch of water in a test tube, and boil the water. You will thus find whether the starch will dissolve in hot water or whether it will settle to the bottom as it did at first. Mix a *very little* of this mixture of starch and water

with
tube,
you h
obtain
of the
starch
from
mixed

Tu
Thou
would
of th
being
starch
insol
the s
up of
of or
in w
in th
whet
with
starch
cont
is en
is pe
not c
It
must

with an inch or two of *cold* water in another test tube, and add a few drops of iodine solution. If you have done the experiment properly you will obtain a beautiful color, very different from that of the iodine itself. This is the iodine test for starch, and will enable you to distinguish starch from other white substances, and to detect it when mixed in very small amount with other substances.

Turn to the material you left in the cloth. Though white it is evidently not starch, else it would have gone through the cloth with the rest of the starch. It differs from the albumen in not being soluble in the juice of the potato, and from starch in not being made up of grains. This insoluble white substance is called *cellulose*; it is the same substance as *pure wood*, but is not made up of fibres like the woody fibre of leaf veins and of ordinary stems. If you like, you may boil in water a little of the insoluble material left in the cloth, and test it with iodine, to find whether any of the starch remained in the cloth with the cellulose. You will probably find some starch remaining with the cellulose, for the potato contains a very small amount of wood; still there is enough wood to hold the tuber together after it is peeled, which the loose grains of starch could not do.

It is evident that the skin or peel of the potato must contain some substance through which water

can only pass very slowly, for if you examine an old potato you will find that it is still quite juicy. The tough layer of waterproof material which covers the potato is really cork. This corky layer corresponds to the white bark of a birch tree, and keeps the water in very effectively.

We have now found that there are six different substances in the potato; but do not conclude that there are no other substances in it. Which of the substances in the potato tuber are to be regarded as food stored up for the future use of the potato plant? You could decide this by considering what substances, found in considerable quantity in the tuber, are not found in dry woody stems, or only in small amount. Cut out a narrow strip from the potato, twist a fine iron wire (florist's wire) around it, leaving part of the wire to use as a handle, and heat it in the lamp or other flame. At first it blackens or chars, but keep it in the flame until a white or gray substance appears outside the black. Press this gray material against a small bit of wet red litmus paper. The paper should change color. A substance which has the observed effect on red litmus is called a base or alkali, and is said to be alkaline. You will notice that the gray substance resembles wood ashes. Try whether wood ashes are alkaline. You will thus find that a potato contains a small amount of *ash*.

1. I
tuber,
2. T
weak
3. I
spot, a
they v

Ma
ing's s
severa
Fehlin
for yo
may b
observ
in 200
Dissol
potash
another
equal
whole

Yo
carro
the c
top v
grow
a ver
bears
a roo
4

EXERCISES

1. Name the different substances you found in the potato tuber, and tell how to distinguish each from other substances.
2. Test a boiled potato for starch. Simply touch it with weak iodine solution.
3. Bury a few tubers in the soil out of doors. Mark the spot, and leave them there for the winter to find whether they will survive.

XII. THE CONTENTS OF A CARROT

Material.—Spirit lamps, porous paper (filter paper), Fehling's solution, if procurable, molasses or glucose, iodine solution, several carrots, a small funnel. If your druggist does not keep Fehling's solution in stock, you may get him to prepare some for you, according to the following directions. The quantity may be varied, as long as the proportions here given are observed: Dissolve 14 grams of copper sulphate (blue vitriol) in 200 grams of water, and put this solution (*a*) into a bottle. Dissolve 69½ grams of Rochelle salt and 64 grams of caustic potash in 200 grams of water. Keep this solution (*b*) in another bottle. When these two solutions are mixed in equal volumes you have Fehling's solution. Do not mix the whole at once, as Fehling's solution does not keep very long.

You cannot find any buds on the sides of the carrot as you did on a potato. This indicates that the carrot is a root and not a stem, except at the top where the leaves grow out. Leaves never grow on a root, so the top of the carrot must be a very short stem. All the rest of it, since it bears neither leaves nor buds, is of the nature of a root.

Cut a carrot across, and also lengthwise through the middle, and look for the parts corresponding to the pith, wood and bark. You will find little, if any, fibrous stringy wood in the wood zone of a carrot of the first year. Note how thick and fleshy is the part which represents the bark, and how small the pith. Observe also the *pith rays* arising from the pith and extending through the wood zone.

Prepare some carrot pulp by scraping a carrot as you did the potato in a former lesson, and squeeze the juice through a fine white cloth. Then test the juice for acid with litmus paper. Note also whether the amount of water is large or small.

Test for albumen by heating the juice in a test tube. If you find albumen, it will probably be stained yellow by the substance which colors the carrot.

Test part of the juice, after it cools, for starch with iodine solution.

To remove solid matter, filter some of the juice, *previously heated*, through porous paper. Put into the test tube about an inch of the filtered juice (that is, enough to fill the test tube to the depth of an inch). Add enough Fehling's solution to impart a blue color and heat the mixture. There should soon be a decided change of color in the mixture. Heat a little of Fehling's solution by itself. No change of color should ensue. We

can
that
stand
man
subs
in w
whet

TH
the
be s
mola
water
appl
whic
are
cont
prin
solu
acce

En
cloth
simi

1.
and t
2.
branc
whetl
wood

can only explain these facts by the supposition that the juice of the carrot contains some substance which will act on Fehling's solution in the manner observed. Why could we not see this substance in the filtered juice? It must be soluble in water, else we would have seen it. Consider whether it could be starch, albumen or cellulose.

The sweetish taste of the carrot suggests that the substance we have found in the carrot might be sugar. To test this, dissolve a very little molasses or grape sugar (glucose) in an inch of water in a test tube. Add Fehling's solution and apply heat. Sugars such as glucose and others which act in this manner on Fehling's solution are called reducing sugars. The carrot is said to contain more than one kind of sugar, but the principal variety in it is *fruit sugar*. If Fehling's solution is not obtainable, the *taste* test must be accepted as evidence of the presence of sugar.

Examine the residue of the pulp left in the cloth, and decide whether it contains cellulose similar to that of the potato.

EXERCISES

1. Name the different substances you found in the carrot, and tell how you distinguish them respectively from others.
2. Get a carrot with some small roots (secondary roots) branching from the main one. Slice the carrot and find whether the secondary roots start from the pith or from the wood zone.

3. Test a parsnip, a beet and a turnip for starch and for sugar.

4. Find whether a carrot contains any ash, and if so, whether the ash is acid or alkaline.

5. Plant in flower-pots, or in the garden, when spring comes, a carrot, parsnip, beet and turnip, and note what becomes of the food stored in the roots. When the plants have fully matured, collect and compare their fruits.

XIII. WHAT WE CAN FIND IN A GRAIN OF WHEAT

Material.—Wheat grains and flour, saucers or small bowls, pieces of thin white cotton or linen cloth, iodine solution, Fehling's solution.

We will use ordinary wheat flour in our experiments to-day. Flour is made from wheat grains by grinding and sifting. Of course, whatever we find in the flour must have been in the grain. If you crush a grain of wheat, you can discover why the flour is different in color from the grain.

Make a ball of stiff dough as large as a small apple by mixing wheat flour with water in a dish. Allow the dough to stand half an hour; then put it into a cloth, soak it in a little water in a shallow dish, and squeeze the water through the cloth, repeatedly, into the dish. Then spread the cloth out in another shallow dish, and pour water slowly over the dough, working the dough with your fingers as you proceed. Keep pouring the water off until it becomes quite clear. The part of the

flour left in the cloth will display properties quite different from anything we found in the potato or carrot. If you have done this experiment successfully, you will have left in the cloth a substance which will stretch a good deal without breaking, and its extension will spring back quickly when you let it go after stretching it. It will also form strings or fibres when you pull one part of it away from the rest. This substance, which is a very valuable part of the wheat grain and flour, is called *gluten* or *fibrin*. Dry the gluten and preserve it for a future lesson.

Turn to the white substance which went through the cloth at first with the water. Note whether it dissolved in the water or settled to the bottom. Boil a very little of it in water and apply the iodine test. Decide which exists in greater amount in the wheat flour—gluten or starch.

Since sugar readily dissolves in cold water, you can find by testing, with Fehling's solution, the water used in saturating the flour, whether the wheat flour contains any appreciable quantity of reducing sugar.

The wheat plant, we find, stores up a generous supply of two substances in its seeds, and that not for itself—for the plant which bears the seed dies as the seed matures—but for its offspring, the young wheat plants, which will grow from these seeds. It was different in the case of the carrot.

In it the plant which stores up the food uses it for its own development, later on its own life history.

EXERCISES

1. Touch a piece of wheat bread with iodine solution, and explain the result.
2. Test Indian corn and other grains for starch, and so forth.
3. Pulverize a bean and test it for starch.
4. Germinate wheat grains in a box of earth and observe the early development of the young plants.

XIV. THE COMPOSITION OF WOOD, STARCH AND SUGAR—CHEMICAL UNION.

Material.—Some small pieces of wood, cotton wool, starch, sugar, spirit lamps, test tubes with corks.

We have found that a potato contains water, starch, albumen, woody material (cellulose) and some other substances. It will be worth while now to inquire what the substances which make up the potato are themselves composed of.

Let us begin with wood. Hold one end of a piece of dry white wood in the flame of a spirit lamp till it begins to char, that is, till a black substance appears. You will find that this black substance is so soft and easily powdered that you can write on paper with it, and if you put the stick into water the black substance does not

dissol
itself
is cal

The
from
subst
coal
whetl
certai
else c
from
wood
conta
of bei
is it t
white
in the
us try

Hea
cotton
as cot
the b
closed
drops
the co
water,
No m
out of
the wa

dissolve in the water any more than the wood itself would do. This insoluble black substance is called *charcoal*.

The charcoal is plainly a very different substance from wood, and could not be generally used as a substitute for wood. Whence then did the charcoal come? Hold something over the flame to see whether the charcoal came out of the flame. It certainly did not come from the surrounding air, else our faces would become black with charcoal from the air. The charcoal must have been in the wood at first, but one would suppose that if wood contained so much black charcoal, the wood, instead of being white, would be black or nearly so. Why is it that the black charcoal does not show in the white wood? There must be some other substance in the wood which hides the charcoal from us. Let us try to find what that other substance is.

Heat very slowly a little dry wood (a ball of cotton wool will answer well for this experiment, as cotton fibre is a very pure form of wood) in the bottom of a test tube, held slantingly and closed with the thumb or with a cork. Soon clear drops of some liquid will appear on the glass in the cooler part of the tube. This liquid looks like water, condenses like water, and feels like water. No matter how dry wood is, you can get water out of it by heating it. Of course you cannot see the water escaping from the wood when the wood

is heated directly in the flame, for the water would then pass off into the air as invisible steam. In the test tube, as the steam could not escape, part of it condenses into liquid water and so becomes visible. Chemists have found that pure dry wood (cellulose) is made up entirely of charcoal (*carbon*) and *water*.

We cannot prove by our simple experiments that wood contains nothing else, but we have found that it does contain these two substances. We must for the present accept the word of chemists, that there is nothing else in pure wood but *charcoal* and *water*.

It is strange indeed that the black charcoal in dry wood does not make it look black, nor the water in it make it feel wet. The charcoal and the water which together form the wood must be united in such a way that each hides the properties of the other. When two substances are so united that they conceal each other's properties, they are said to be *chemically united* or to be in *chemical union*.

Mix some charcoal and water together in a bottle and see whether they unite chemically. No, they do not hide each other's properties; for the charcoal makes the mixture black, and the water makes it feel wet. In a piece of dried white wood we have just the same two substances, but they are chemically united in the wood, and neither of

them
This

Wl
decon
in th
fact t
becor
the w
cellul
in th
subst
water
whiel
from

Ex
did v
chare
yield
it cor
wood
Appl
own

Sir
and v
they
coal
water
wood
respe

them shows at all till they are chemically separated. This we did by heating the wood.

When the wood was heated it underwent *chemical decomposition*. If you continue to heat the wood in the closed test tube you may be confused by the fact that the clear liquid water which first appears becomes colored by something which dissolves in the water. This is due to the fact that although cellulose is composed of carbon and water only, in the process of chemical decomposition new substances are formed from the charcoal and water; but these new substances contain nothing which is not in the wood, that is, they are formed from the charcoal and water in the wood.

Examine dry starch in the same way that you did wood. If it chars you know that it contains charcoal. If when you heat it in a closed tube it yields water, as the wood did, you may infer that it contains water as well as charcoal, and that, like wood, it is made up of these two substances. Apply the same tests to sugar, and draw your own conclusions.

Since dry wood, sugar and starch yield charcoal and water when heated moderately in a closed tube, they are called *carbohydrates*—*carbo* denoting charcoal (carbon), the rest of the name denoting the water. It is remarkable that starch, sugar and wood, which differ from each other in so many respects, should be composed of the same two

substances—carbon and water. We have seen that the charcoal and water are chemically united in these carbohydrates, for wood, sugar and starch are quite different in their properties from either carbon or water. No one would mistake either of them for carbon or for water, neither does the carbon show its color nor the water its wetness in any of the three.

You remember that we found water and starch in a potato. Were *they* chemically united? No, for the properties of the water were evident in the potato juice, and when we touched the pulp of the potato with iodine solution a blue color appeared, showing that the starch is not chemically united with anything, else it would not display this property. Besides, we washed the starch out of the pulp, which we certainly could not do if it were chemically united with another substance.

When a substance is not in chemical union with another it is said to be *free* or *uncombined*. The water in potato juice is *free*, but the water in dry wood is *combined* with charcoal.

Since wood is made up of two substances chemically united, it is called a compound substance, or a *chemical compound*. As no one has been able to find anything in charcoal except charcoal, it does not seem to be composed of two different substances, and it is therefore called a *simple substance* or a *chemical element*.

XV.

Mate
and sh
suitabl
instead
or thre
(quickl
lime do
and cr
slacked
into a
through
become
acid or
called
up the
in mak
to the

Rec
away
mains
is neit
What
Set
burnin
have
end.
going.
rising
invisib
the fla

XV. WHAT BECOMES OF WOOD WHEN IT BURNS

Material.—Wide-mouthed bottles, matches, small sticks and shavings of dry wood, bowls and basins, and a jar. If suitable bottles are not available deep tumblers may be used instead. Lime-water for this lesson should be prepared two or three days in advance, as follows: Soak a lump of lime (quicklime) in water in a bowl, pour off the water which the lime does not absorb. Soon the lime will become quite hot and crumble into a dry powder. This dry powder is water-slacked lime. Put a few tablespoonfuls of the slacked lime into a jar. Fill the jar with water and stir the slacked lime through it. Cover, and set away to settle. When the water becomes clear, test it with litmus paper, to find whether it is acid or alkaline. This clear *solution of water-slacked lime* is called *lime-water*. Cover the jar to keep out the air. Cork up the remainder of the lime in a bottle and save it for use in making lime-water. It will change if you leave it exposed to the air.

Recall the fact that a stick of wood soon burns away in a stove. No wood or even charcoal remains—only a small quantity of gray ash, which is neither wood nor charcoal since it will not burn. What becomes of the wood? Whither does it go?

Set fire to a thin shaving of dry wood; keep it burning without smoke, till the wood and charcoal have all disappeared for some distance from the end. The wood is gone, yet you did not see it going. You saw the flame, but you saw nothing rising out of the flame; nevertheless, some gas, invisible to you, may have been ascending from the flame.

Set fire to one end of a dry stick, not larger than a lead pencil. Hold it so that it will burn with a small smokeless flame below the mouth of a dry wide-mouthed bottle, held inverted over the flame. See the liquid collecting on the inside of the bottle. Feel this liquid with your finger and taste it. Recollect that dry wood is composed of charcoal and water. *Water* from the burning wood must have risen out of the flame as invisible steam. You could not see the water till the steam condensed into liquid water on the glass.

Rinse the bottle, wipe it dry, and hold it again mouth downward over the smokeless flame of a burning stick. In a minute or even less, place the palm of your hand tightly against the mouth of the bottle to keep any gas which may have risen into the bottle out of the flame from escaping, and then turn the bottle mouth up. Partially remove your hand and quickly empty a little clear lime-water into the bottle. Cover the bottle tightly again as soon as the lime-water is in, and shake the lime-water *up and down* through the gas in the bottle. If you do this experiment carefully, you will see a decided change in the appearance of the lime-water.

There must have been in the bottle a gas which produces this effect on the lime-water. This gas was not in the bottle before it was held over the flame, as you can prove by shaking lime-water through

a bottle
risen out
known
it from

When
they as
pass on
Now w
water a
that the
acid gas
become
at ordi
must c
bon of
be chem
each of
This m
substan

1. Put
flame of
catch the
they are
burning
2. Try
3. Wh
of the tw
really bu
4. WH
place of

a bottle of air. The gas, therefore, must have risen out of the flame into the bottle. This gas is known as *carbonic acid gas*. We can distinguish it from other gases by its effect on lime-water.

When we burn wood, then, we may catch as they ascend from the flame two substances which pass off as gases—water and carbonic acid gas. Now wood consists of water and carbon—not of water and carbonic acid gas. This seems to show that the carbon of the wood must be in the carbonic acid gas. If this gas were pure carbon it would become solid carbon as it cools, for carbon is solid at ordinary temperatures. So carbonic acid gas must contain some other substance than the carbon of the wood; and the carbon in the gas must be chemically united with that other substance, for each of them conceals the properties of the other. This means that carbonic acid gas is a compound substance.

EXERCISES

1. Put some starch in an iron spoon and hold it over the flame of a spirit lamp, till the starch bursts into flame. Then catch the gases which arise from the flame, and find whether they are the same as those which come out of the flame of burning wood.

2. Try the same experiment with sugar.

3. When we burn wood or any other carbohydrate, which of the two substances which make up the carbohydrate do we really burn?

4. Why can we not see anything except a little ash in place of the wood which we burn in our stoves?

XVI. WHAT CARBONIC ACID GAS IS COMPOSED OF—OXIDATION

Material.—Charcoal, crystallized chlorate of potash, black oxide of manganese, lime-water, wooden toothpicks, small hardwood sticks, small squares of window glass, brass wire.

Procure some wood charcoal from a stove or by charring a piece of wood. Wind a piece of brass wire about a piece of charcoal, closely enough to prevent it from falling out. Leave part of the wire projecting for a handle. Shake together in a test tube a few crystals of chlorate of potash and a much smaller bulk of black oxide of manganese. Try a test stick (a hardwood toothpick is just the thing), first merely glowing at the tip, then burning with a flame, in the mouth of the test tube. Note the results, if any.

Heat the mixture with a spirit lamp, till a stick with a glowing tip will burst into flame when held in the mouth of the tube. Hold the tube away from the lamp and repeat the experiment until the stick will no longer burst into flame.

This gas cannot be air, for the glowing stick does not act in that way while it is in the air. This gas in which a stick burns so much faster than in air is called *oxygen*. Oxygen is another substance which has never been broken up into two different substances, and so is classified as a *simple substance* or *chemical element*.

Add
ture in
tube in
held w
and ap
promp
of the
bottle
charco
momen
oxygen
which
close l
the ch
into th
bright

Take
out of
has ha
a little
change
once t
ing th

If r
sure v
the n
explai
Since
have l

Add a little more chlorate of potash to the mixture in the test tube. Insert the mouth of the test tube into the mouth of a small wide-mouthed bottle held with the mouth turned obliquely downward, and apply heat to the tube till a glowing stick will promptly burst into flame when held in the mouth of the *bottle*; then quickly cover the mouth of the bottle with a wet piece of glass. Heat the prepared charcoal till part of it is glowing. Hold it for a moment in the air, then lower it into the bottle of oxygen, allowing a piece of cardboard, through which you have passed the handle of the wire, to close loosely the mouth of the bottle. Note whether the charcoal becomes hotter or colder when put into the oxygen, and whether it glows more or less brightly than before.

Take the wire with the remaining charcoal in it out of the bottle and, quickly, before the gas in it has had time to mingle with the air outside, shake a little clear lime-water through it. The apparent change in the lime-water will convince you at once that carbonic acid gas was formed by burning the charcoal in the oxygen.

If necessary, repeat the experiment to make sure whether the charcoal was disappearing as the new gas was being formed. You should explain, too, why the charcoal stopped burning. Since it was not for lack of charcoal, it must have been for lack of oxygen.

Now we must enquire what the carbonic acid gas is composed of. It cannot be carbon gas, that is, carbon in the form of gas, for if it were it would become a solid as soon as it cooled down to the ordinary temperature. Neither is it something out of the carbon, for charcoal is a simple substance. As oxygen is also a simple substance the carbonic acid gas could not have come out of the oxygen. Since it is neither carbon nor oxygen, nor a part of either, it must be formed of the two chemically united together. This is made the more certain by the fact that both the charcoal and the oxygen were gradually disappearing in the bottle at the time the carbonic acid gas was being formed. They were evidently disappearing by entering into chemical union, when each concealed the properties of the other, and a new substance with different properties from either was formed. Because this gas is made up of oxygen and one other simple substance it is called an *oxide*. As an oxide, carbonic acid gas is called *carbon dioxide*. When carbon or any other substance unites with oxygen it is said to *oxidize* or undergo *oxidation*.

But how can we account for the charcoal becoming so hot while the oxidation was going on? It must be that the chemical union in some way produced or caused the heat and the bright light, for as soon as the oxidation ceased, both the heat

and
be c

1.
breat
effect
in th
2.
take
3.
ture
4.
taken
5.
oxidi
6.
anim
7.
duce

M
wate

B
cha
Ren
wat
han
thro

and the light disappeared. Heat so produced may be called *heat of chemical union*.

EXERCISES

1. Put some lime-water into a small bottle and blow your breath through it by means of a tube till you get a decided effect. Argue from this experiment that carbon is oxidized in the body.
2. In what part of the body does the oxidation of carbon take place and at what temperature?
3. Find whether charcoal can be oxidized at this temperature outside of the body.
4. Where and how is the charcoal oxidized in the body taken in? How often?
5. Where and how is the oxygen, used in the body for oxidizing carbon, taken in? How often?
6. Prove by experiment that both vegetable food and animal food contain carbon.
7. Mention a case in which the oxidation of carbon produces heat without light.

XVII. THE COMPOSITION OF THE AIR

Material.—Wide-mouthed bottles, dry pieces of wood, lime-water, a pitcher, tumblers or bowls, snow or ice, salt.

Burn without smoke for less than a minute the charred end of a dry stick in a bottle full of air. Remove the stick quickly, pour a little clear lime-water into the bottle, close its mouth with your hand, and shake the lime-water *up and down* through the bottle. You can tell by the result

that carbonic acid gas was formed by burning the charcoal in the bottle.

Now that gas, as we found before, is a compound gas, made up of carbon and oxygen chemically united. The stick supplied the carbon (charcoal), but whence came the oxygen necessary to unite with the carbon? The carbon of the stick must have obtained the oxygen from the air which surrounded it; hence the air must contain *oxygen*.

The air, however, cannot be pure oxygen, else a glowing stick would burst into flame in the air as it does in oxygen. There must be some other gas mixed with the oxygen in the air—a gas which does not allow a stick to burn in it, for it prevents things from burning as rapidly in air as they would in oxygen. The gas which does this is mostly *nitrogen*.

Notwithstanding the nitrogen in the air, the oxygen united with the burning charcoal; the nitrogen too displayed its own properties, by hindering the combustion. Since the oxygen and nitrogen in the air do not conceal each other's properties, we may conclude that they are not chemically united, but are merely intermingled.

Let us seek for other gases in the air. Look for water first. Fill a pitcher with water at the temperature of the room; no water soaks through or collects on the outside of the pitcher. Fill the pitcher with a mixture of snow or broken ice and

compr
of th
throu
out o
of th
must
canno
invisi

We
(carbo
bottle
you a
carbo
that
of air
If th
a lon

Fill
and l
the li
siona
formi
Since
the a
Now
water
is car
to fo
deep,

common salt. Water does collect on the outside of the pitcher. As the water could not soak through the sides of the vessel it must have come out of the air around the vessel; therefore the air of the room must contain water, but that water must exist in the air as an invisible gas, for we cannot see it till it condenses into a liquid. This invisible gas is in fact *steam*.

We will next test the air for carbon dioxide (carbonic acid gas). Shake lime-water through a bottle of air. The water remains clear. At first you are inclined to decide that the air contains no carbon dioxide; but this experiment only shows that there is not enough carbon dioxide in a bottle of air to have any visible effect on the lime-water. If the lime-water were exposed to the open air for a longer time there might be a perceptible effect.

Fill a tumbler or bowl half full of lime-water and leave it exposed to the air. Do not disturb the lime-water for some days, but look at it occasionally. You will observe a scum gradually forming on the exposed surface of the liquid. Since this scum only forms where the liquid meets the air, it must be caused by something in the air. Now we know that carbon dioxide acts on lime-water when mixed with it. To decide whether it is carbon dioxide in the air which caused the scum to form, put some lime-water in the bottom of a deep, wide-mouthed bottle. Burn a charred stick

in the bottle above the lime-water for a short time and quickly cork the bottle, or cover it with a slip of glass which has been smeared with vaseline, so that it will not let the gas escape from the bottle. Notice whether the scum forms more or less slowly than it did when the lime-water was exposed to the open air. Repeat the experiment if necessary. I think you will be able to show from this experiment that the air contains a small proportion of *carbonic acid gas*.

We have now found four gases in the air. There are others there in small proportions, but we cannot find them at present.

EXERCISES

1. Show whether nitrogen has any visible effect on lime-water.
2. Mention three gases in the air, in neither of which, when pure, will a stick burn.
3. When charcoal burns in the air, with which of the gases there does it unite? Why does it not unite with one or more of the others?

XVIII. THE COMPOSITION OF WATER

Material.—Small pieces of zinc (granulated zinc is best), hydrochloric acid, test tubes, delivery tubes with corks or rubber stoppers, tumblers or wide-mouthed bottles. If delivery tubes are not available, the following experiments can be performed without them. By generating the gas in small bottles, even test tubes may be dispensed with.

Put small pieces of zinc to a depth of an inch

into a test tube. Add enough dilute hydrochloric acid to cause an active bubbling (effervescence). Insert a cork through which passes a delivery tube of $\frac{1}{4}$ -inch bore. Hold a small wide-mouthed bottle inverted over the mouth of the tube to catch the gas as it issues. In about a minute, hold the bottle a short distance away from the tube with the mouth still turned downward, and set fire to the gas you caught in the bottle. Repeat the experiment till you see how fast the gas burns, and note the color of the flame. Turn the mouth of a bottle full of the gas upward at once, and find whether the gas will stay in the bottle till you set fire to it. Show that this gas is neither oxygen, nitrogen nor carbon dioxide. This combustible gas is called *hydrogen*, and like oxygen and nitrogen it is a simple substance.

We should next try to find what becomes of the hydrogen when it burns. Pour the liquid off the zinc in the test tube. Add acid as before. Insert the cork with the delivery tube and set fire to the hydrogen as it issues from the tube. Can you see anything issuing from the flame of the burning hydrogen? Hold a dry tumbler mouth downward just above the flame till a liquid condenses on the inside of the tumbler. Examine this liquid by taste and touch. How do you account for the fact that you did not catch any hydrogen in the tumbler?

Since water is the only substance we can find coming out of the flame in which the hydrogen is burning, we must conclude that water is the only substance which is produced by burning hydrogen in the air. We have found that when carbon burns in the air it unites with the oxygen there to form carbon dioxide, so it is highly probable that when hydrogen burns in the air it also unites with the oxygen in the air to form an oxide of hydrogen. As water is the only substance we found arising from the flame, we must conclude that water is this oxide of hydrogen and is composed of hydrogen and oxygen in chemical union. Hereafter, then, we must remember that water is *hydric oxide*; but we will still continue to speak of it by its familiar name.

EXERCISES

1. Why can you see nothing coming out of the hydrogen flame?
2. Explain why water and carbon dioxide will not burn.
3. Explain how water extinguishes a fire.
4. What is really happening to a house when it is on fire? What invisible products are going off into the air from the fire?
5. Note whether solid sulphur, without heating or rubbing, has any smell, and try whether it is soluble in water. Burn a little sulphur without smoking, and find whether any gas comes out of the flame. How is this gas easily detected? Argue out the composition of this gas. It is called sulphurous acid gas. Shake a little water through a bottle containing the gas and test the solution with litmus paper.

XD

Mat
saucers
sal amMix
ammc
you s
mixtu
lime
gas.Put
tube,
mixtu
monia
a sma
tube
minu
shalle
lifting
shoul
Test
with
gas is
with
losing
soluti
Yo
prope

XIX. AMMONIA GAS AND ITS COMPOSITION

Material.—Tumblers, test tubes, spirit lamps, small bottles, saucers or large nappies, litmus paper, water, lime (unslacked), sal ammoniac.

Mix in a dish about equal volumes of sal ammoniac and powdered lime (quicklime). Can you smell or see anything coming off from the mixture? The pungent gas which is set free by lime from the sal ammoniac is called ammonia gas.

Put a teaspoonful of the mixture into a test tube, and apply heat slowly. Do not make the mixture hot enough to smoke. Catch the ammonia—which is now set free more rapidly—in a small bottle, held so that the mouth of the test tube just enters the mouth of the bottle. In a minute or two, set the bottle, mouth down, in a shallow dish of water. Shake the bottle without lifting its mouth out of the water. The water should rise until it fills, or partly fills, the bottle. Test the ammonia still escaping from the test tube, with litmus paper, to find whether the ammonia gas is acid or alkaline; also try to set it on fire with a match. Turn the bottle mouth up, without losing the water which rose into it; taste the solution in the bottle, and test it with litmus.

You have illustrated in these experiments several properties of ammonia gas, but you have not found

what the gas is composed of. We cannot prove that by means of the simple apparatus we are using, so we will have to accept, without verification, what the chemists say about its composition. This is regrettable, but it is the best we can do at present.

Chemists have found that ammonia is a compound gas composed of two other gases, with both of which we have met, viz., *nitrogen* and *hydrogen*. We found nitrogen in the air some time ago, and we prepared hydrogen quite recently and found it to be one of the elements of water.

EXERCISES

1. Compare ammonia with each of the two gases of which it is composed. What does the fact that it differs so much from them indicate?
2. Try whether water will rise into a bottle of air when stood mouth down in water, as it does into a bottle containing ammonia gas. Explain the result.
3. Why did the water rise higher in some of the bottles containing ammonia than in others?
4. What became of the ammonia gas when the water rose into the bottles? Give reasons for your answer.
5. Show whether there is much ammonia in the air.
6. Show whether ammonia is an acid or an alkaline gas.
7. Since lime contains neither nitrogen nor hydrogen, what can you prove, from your experiments, about the composition of sal ammoniac?
8. Show whether sal ammoniac contains anything besides ammonia gas.

X

Mat
beans;
some si

We
and g
on di
effect
into a
could
bulk
togeth
is sti
Heat
red li
the es
in th
appea
Rej
glute
alkali
amm
amma
same
by th
time.
As

XX. WHAT THE GLUTEN OF WHEAT IS COMPOSED OF

Material.—Powdered starch, wheat flour, dried gluten and beans; litmus paper, red and blue, test tubes and spirit lamps; some simple contrivance for pulverizing the gluten and beans.

We will first try whether lime will act on starch and gluten as it did on sal ammoniac. Rub lime on damp red litmus paper and note the visible effect. Put about $\frac{2}{3}$ of an inch of powdered lime into a test tube. Add as much powdered starch as could be piled on a five-cent piece (or about the bulk of a pea), mix the lime and starch well together by shaking the tube. See that no lime is sticking to the glass in the mouth of the tube. Heat the mixture while you hold a strip of damp red litmus paper in the mouth; note the smell of the escaping gases, and whether there is any change in the color of the litmus paper. If no change appears, try damp *blue* litmus paper.

Repeat the preceding experiment, using powdered gluten instead of starch. You will find that an alkaline gas is set free by the lime, as when sal ammoniac was heated with lime. *That gas was ammonia*; it is likely then that this gas is the same. The odor of the ammonia may be disguised by the smell of other gases set free at the same time.

As no ammonia was set free when we used

starch, we must infer that the ammonia was set free by the lime acting on the gluten; therefore gluten must contain nitrogen, for ammonia contains nitrogen.

Try whether dried gluten will char. This is a test for carbon.

Besides carbon and nitrogen, gluten has been found by chemists to contain hydrogen, oxygen and a little sulphur—that is, it contains the three elements which make up the carbohydrates and two others — nitrogen and sulphur. We have proved that gluten contains carbon and nitrogen, but we cannot prove at present that it contains the other three elements.

Albumen, which you found in the potato, has been analyzed, and has been found to contain the same elements as gluten. Evidently gluten and albumen belong to a class of compounds much more complex than the carbohydrates.

The class of compounds to which gluten and albumen belong is called the proteins or proteids. They are often spoken of as nitrogenous compounds, because they differ from the carbohydrates in containing nitrogen. Recollect here that nitrogen is that gas mixed with oxygen in the air which dilutes the oxygen to such an extent that a glowing stick will not burst into flame in the air. Indeed it has been proved that about four-fifths of the air is nitrogen.

1. Pu
you did
and mal
is called
which d
2. Te
starch a
color of
3. Fi
4. Te

XXI.

Mates
some ot
litmus }
slacked

Oils.
will o
one sic
about
resembl
and ta
will r
which
is the
these
will ex

EXERCISES

1. Pulverize a well dried bean and test it for proteins, as you did gluten—by heating a mixture of bean meal and lime and making the litmus test. The principal protein in beans is called *legumin*. That name is taken from the word *legume*, which denotes a pod such as that of the bean.

2. Test sugar for nitrogen in the same way as you did starch and gluten. If the gases set free have no effect on the color of red litmus paper, try blue litmus.

3. Find whether Indian corn meal contains gluten.

4. Test Indian corn meal with hot lime for proteins.

XXI. VEGETABLE OILS AND ACIDS AND A SALT

Material.—Grains of corn soaked till quite soft, olive oil or some other vegetable oil, pieces of thin, white writing paper, litmus paper, sour fruits, starch, cotton wool, sugar, water-slacked lime, spirit lamps and test tubes, enamelled plates.

Oils. Look at a grain of soaked corn and you will observe, showing through the seed-case on one side of the grain, the outline of a body perhaps about one-fourth of an inch long and in shape resembling the half sole of a boot. Open the grain and take this body out. It is quite thick, and you will recognize it as the part of the grain from which the young plant sprang in germination. It is therefore called the *germ*. Remove several of these germs from the grains and dry them. We will examine this part of the grain for oil.

Place a drop of olive oil or any other vegetable oil on a piece of thin writing paper, and hold the paper between you and the window. The oil spot on the paper will become nearly transparent. As olive oil is a fixed oil, the spot will remain indefinitely.

Crush two dry germs of Indian corn and place the fragments on a square slip of white writing paper. Lay the paper on an enamelled plate, and heat the plate slowly over a lamp or on a stove or radiator, taking care not to burn or char the paper. Press the fragments against the paper. In a short time you should get a clear spot (on the paper) resembling an oil spot, and permanent like it.

The oil spot can be obtained without heat by covering the fragments of the germs with a few drops of benzene. The benzene will dissolve out oil which will leave a spot on the paper after the benzene itself has evaporated. But benzene is such an inflammable substance that it is not safe to use it in a school. Gasoline and ether will also dissolve oil, but they also are very inflammable.

Mention other plants which store up oil in their seeds or fruits.

Put a few drops of a vegetable oil into a teaspoon and hold the spoon in the flame of a spirit lamp until the oil takes fire. It will burst into flame sooner if you tip the spoon a little, so

that t
the fl
down,
gather

Cato
escap
promp
shake
the bo
hand.

You
and e
burnin
the ai
substa

air.
in ord
forme
gen u
forme
oil mu

We
for wh
taking

howev
not so
that v
the ca

Acid

that the hot oil will approach the edge close to the flame. Hold a wide-mouthed bottle, mouth down, over the flame. Feel the liquid which gathers on the inside of the bottle.

Catch in the bottle again the invisible gases escaping from the flame. Place your hand promptly over the mouth of the bottle and shake a little lime-water *up and down* through the bottle which you still keep closed with your hand.

You should now be able to prove that both water and carbon dioxide rise out of the flame of the burning oil. But when a substance is burning in the air—as we have shown before—it or some substance in it is uniting with the oxygen of the air. Now what substances must the oil contain in order that water and carbon dioxide may be formed by burning it? Water is formed by hydrogen uniting with oxygen, and carbon dioxide is formed by carbon uniting with oxygen; hence the oil must contain carbon and hydrogen.

We cannot prove that the oil contains oxygen, for when a substance is burning in the air it is taking oxygen *from the air*. Chemists tell us, however, that most oils contain some oxygen, but not so much as carbohydrates do. It seems, then, that vegetable oils contain the same elements as the carbohydrates, but in a different proportion.

Acids. Heat a bit of starch in a tube, closed with

your thumb, until gases with a strong smell are given off. Then put a piece of blue litmus into the tube. The effect will show that an acid has been formed. Now since the acid has been formed from the starch, it is evident that the acid contains no other elements than those of starch — viz., carbon, hydrogen and oxygen. We have not proved, of course, that it contains all of these, and will therefore be compelled to accept that conclusion on the authority of chemists.

Cut slices off several sour fruits, and press a piece of blue litmus paper against the juicy pulp. You will find that the effect indicates an acid in each case. The sour taste common to all of these fruits must be due to the presence of the acids, so we must consider a sour taste as good an indication of an acid as the litmus test. The principal acid of the apple is called *malic acid*, from the Latin word "*malum*," which denotes an apple. The distinctive acid of the lemon is called *citric acid*. These acids are also found in other fruits, but there are many different vegetable acids.

Find whether the two other carbohydrates you have met with—sugar and cellulose—yield acids when heated in a closed tube. You may use cotton wool for wood, as it is nearly pure cellulose.

A Salt. Squeeze the juice out of half a lemon. Taste it and test it with litmus paper. To what is

the taste
water-soluble
paper.
that water-soluble
substance
on litmus paper.
Stir the mixture.
little acid is
blue litmus paper
very sensitive
nor an indicator
sary.
Set the test-tube
on a boiling-water
bath.
The acid is
called malic acid.
that a malic acid
salt.
can be obtained
of the juice
the salt.

the taste and the action on litmus due? Taste water-slacked lime, and test it with damp litmus paper. The taste and the effect on litmus indicates that water-slacked lime belongs to the class of substances called *bases* or *alkalies*. Their action on litmus is just opposite to that of an acid.

Stir water-slacked lime into the lemon juice, a little at a time, until the liquid will neither turn blue litmus red nor red litmus blue, or at least very slowly, and till the liquid has neither a sour nor an alkaline taste. Dilute with water, if necessary. Strain the liquid through porous paper. Set the dish over the flame of a spirit lamp, or on a hot stove or a radiator, until the water has evaporated.

The dry residue which remains in the dish is called a *salt*. This is a salt of citric acid, because that acid was mixed with a base to produce the salt. The name of this salt is *citrate of lime*. You can see that this name is formed from the names of the acid and base which were mixed to produce the salt. Taste and describe citrate of lime.



XXII. TREES IN WINTER

Material.—Small branches from various trees, jars or large bottles containing water, tincture of iodine, spirit lamps.

It is now past midwinter and the trees have been exposed for many weeks to all the severities of our northern climate. Let us examine branches of some of them, and try to learn what the trees have been doing, or whether they have simply been "standing it" till spring should arrive.

You can readily tell whether the branches have grown any longer or the buds any larger than they were in the autumn. It will be interesting to try whether the dormant buds can be got to develop at this season, several weeks sooner than their usual time. If we place them in spring conditions will they respond as though it were really spring? Let us try.

Set a few branches from neighboring trees—willows, poplars, apples, etc.—in jars or bottles of water, and stand them in a warm, sunny room at home or in the school building. Change the water occasionally, and note any signs of life which become apparent in the buds.

Bring in fresh branches from time to time, and remove from the water those which fail to show a satisfactory response to the new conditions. Before long some buds will begin to develop.

Note
scars
to see
whetl
into a
the n
which
Sor
branc
leaf-b
foliag
beco
of flo
instea
A f
a spec
as an
corres
branc
quite
In
fail to
leave
or wh
Rec
begin
the le
and c
an av
e

Note whether the bud-scales leave any marks or scars behind them when they drop off, and watch to see what each bud becomes. Especially observe whether a leaf-bud simply develops into a leaf or into a branch bearing one or more leaves. Count the number of leaves which appear on the branch which develops from one bud.

Some of the buds may develop into short branches bearing flowers or flower-clusters. A *leaf-bud* develops into a branch bearing one or more foliage-leaves; whereas a *flower-bud* or *fruit-bud* becomes a short branch, bearing one or more sets of flower-leaves (sepals, petals, stamens, carpels) instead of foliage-leaves.

A flower, then, with its stalk may be regarded as a special kind of branch, for it comes from a bud as an ordinary branch does, and its flower-leaves correspond to the foliage-leaves of a common branch, though no doubt their uses (functions) are quite different.

In watching the growth of the bud, you will not fail to notice whether the leaves *grow*—from little leaves when they first appear to be large leaves—or whether they merely unfold.

Record the date at which some particular bud begins to swell. In two or three weeks measure the length of the new branch into which it grew, and calculate how much it increased in length, on an average, in one week—in one day—in one hour.

EXERCISES

1. Early in the winter we may begin to test the branches and buds of trees, to find whether there is any food stored in them to nourish the buds in spring when they begin to grow, and to assist in the formation of new wood and bark in the older parts of the branches and in the main stem. Cut off short pieces from the branch ; split them and test them for starch and sugar. Test the buds themselves as well as the stem for stored food.

2. Near the close of the winter, but before the buds begin to swell, you may find signs of activity in the main stem and branches. Pull off some of the bark and test the juicy layer under it by taste, and in other ways. This part of the stem and its branches is called the *cambium layer*. Examine it again later in the season, and try to find what becomes of the food materials you found.

s
n
e
f
r
e

n
d
r
n
t
f

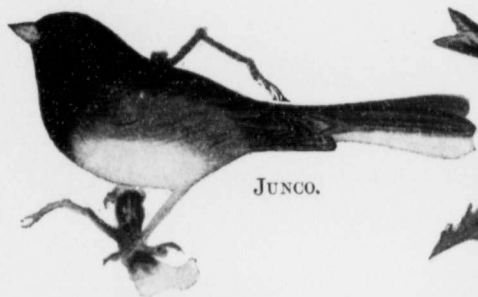

JUNCO.



AMERICAN
GOLDFINCH.



SONG SPARROW.



VESPER SPARROW.



PHOEBE.



TOWHEE.

From "Birds of Canada."—NUTTALL. (Reproduced by permission.)

A
you
earl
wer
whi
obe
exc
brig
the
of t
Rok
mel
mon
tinc
I
sim
of
whi
me
con
T
hak
tin

SPRING LESSONS

XXIII. THE RETURN OF THE BIRDS

At the first indication of the approach of spring you may be on the watch for the return of the earliest of the feathered songsters who last autumn were impelled southward by a strong impulse which nearly all our wild birds feel and must obey. While yet the snow overspreads the fields, except in a few favored spots, we may wake any bright morning to hear again the sweet note of the Song Sparrow, the more monotonous measure of the Junco, or the cheerful song of the American Robin. As the days lengthen and the sun-heat melts the snow and releases the ice-bound streams, more species continue to arrive, each with its distinctive song, plumage and habits of life.

I am sure that it will add much to the pure and simple pleasures of your lives to learn the songs of the birds—not perhaps well enough to sing or whistle them—but at least to print them on your memory so clearly that you can distinguish all the commoner birds by their notes.

The marked differences in the plumage, size and habits of the species will soon enable you to distinguish those which frequent the near-by fields,

trees and waters. Of course these are not all birds of song, but all have their peculiar calls and cries. The school library should contain a good book on birds, with descriptions of the species which may be found in your region; and there may be a bird lover in your neighborhood who is sufficiently well acquainted with birds to give you their names from your descriptions. If these means fail, the descriptions may be sent to some authority on birds, who will be glad to send you their names. Be careful, however, to give descriptions which bring out the distinctive characteristics of each species.

But let me beg of you not to shoot the bird to settle the question of its name. It is far better that you should never know the name than that you should take its innocent life. Close observation and patient waiting will be rewarded in nearly every case by the discovery of the bird's identity; and, if not, the training will be good for you, and help to make you keener of eye and steadier in purpose.

As spring advances, you will find great delight in watching the happy and industrious home-life of the birds which build their nests in your neighborhood. You can induce many birds to set up housekeeping close to your home and your school, by providing nesting-places for them in the way of little houses made of old boards or pieces of

holl
man
whic
low
you
ally,
for
E
thei
hato
and
mai
for
to t
of
inse
the
cro
gre
I
ma
anc
alth
wo
Th
wh
tha
oth
or

hollow logs set up on tall poles. You may attract many birds too, by planting trees and shrubs which yield fruits agreeable to the birds. A shallow dish set on top of a pole or on a shelf outside your window, and supplied with water occasionally, will be a great convenience to birds as a place for drinking and bathing.

Every day you will learn something new about their ways, as you watch them making their nests, hatching their eggs, and feeding their young; and you will find that nearly all these birds feed mainly on weed seeds, or else upon the various forms of insect life. Birds thus render a service to the country which can only be stated in millions of dollars. Were it not for the birds, destructive insects would certainly multiply so rapidly that the annual loss, due to their ravages upon our crops, orchards and forests—which is now very great—would be vastly increased.

It is true that sometimes a flock of birds will make a run upon a cherry tree or a grain field, and may thus cause loss to a single person, although the species in the long run may be worth much more to the country than it costs. The English Sparrow, however, is one bird for which little defence can be made. I can only ask that, in destroying these sparrows by poisons or otherwise, care may be taken not to destroy useful or harmless birds of other species.

Allowing for such rare exceptions, let us all do our part to protect and encourage bird life. We can thus render valuable service to our country, while at the same time the simple and gentle lives of the birds will help to sweeten our spirits and divert our thoughts from the cares and worries which even children sometimes feel. Our ears will gradually become more sensitive to the birds' songs and other soothing influences of nature through which the kind Father of all life would speak peace to troubled hearts.

In the spring-time, too, many wild things, from the clumsy toad to the graceful deer, which have solved with more or less success the problem of existence in the winter without migration, will emerge from retirement to play their parts in the drama of life. Let me bespeak from you a generous treatment of these defenceless wild creatures. The world would be a much less interesting home for man without them. We want our country to be well cultivated and productive, but we can surely spare a little space and a little food for our lowlier brethren of the wild.

"He prayeth best who loveth best
All things, both great and small ;
For the dear God who loveth us,
He made and loveth all."

X

Me
ting
garde
incluIn
soak
then
of v
plate
inve
num
can
the
timeW
min:
for
can
the
root
seedW
from
shou
ster
thiel

XXIV. THE SEED AND THE LITTLE PLANT WITHIN IT

Material.—Flower-pot saucers, table plates, pieces of blotting paper or flannel, flower-pots, shallow wooden boxes, garden soil, a collection of seeds—some large and some small, including beans and grains of corn.

In the latter part of March or early in April, soak a few beans and grains of corn, and place them between damp pieces of blotting paper or of woollen cloth in a flower-pot saucer or table plate, and cover the whole with a shallow dish inverted over the cloth or paper. Record the number of each kind of seed used, so that you can calculate the percentage of good seeds. Keep the dishes in a warm place and add water from time to time to keep the paper or cloth moist.

When you find the seeds are beginning to germinate, soak some more beans and grains of corn for a day or two, until the seed-coat or seed-case can be easily removed from the seed. Examine the germinating beans to see at what point the root-end of the growing plant emerges from the seed-coat. Find the same place in a dry bean.

When the young bean plant has entirely escaped from the seed-coat, examine it again with care. It should have a pair of thin veiny leaves, a short stem upon which these leaves grow, a pair of thick, fleshy organs below the pair of thin leaves,

and a continuation of the stem below these, terminating in a root-like part. The two fleshy organs grow on the same stem-like part as the two thin leaves, so we must classify them also as leaves—the first or lowest pair of leaves. The root-like part of the little plant will soon bear root-hairs. We have here then a complete plant with all the organs of vegetation—stem, leaves, root and root-hairs.

Now remove the coat from a recently soaked bean, taking care not to break or injure anything inside the coat. Note that the body which you have left in your hand, after removing the coat, has all its parts connected together. You will find the two thick leaves, the short stemlet from which they grew and with which they are still connected, bent up against their edges. Part them slightly or break one of them off, and you will find two thin leaves. Evidently the free end of the stemlet develops into the first or primary root upon which a little later the root-hairs form. So we have found in the seed of the bean, before germination has begun at all, a complete but undeveloped bean plant, with a stem bearing four leaves, and at the free end of the stem the possibility of a root.

This little plant contained in the seed is known as the *embryo*, but we will call it for the present the *seed-plantlet*. The two thick leaves are called

the
leave
are n
leave
blanc
point
Ther
It
of tw
whic
is ma
they
befor
the t
yet c
In
(star
Thes
in th
woul
plant
Se
soil
and
Also
Ex
bean
of th
germ

the *seed-leaves*, because they are the principal leaves of the seed-plantlet. The two thin leaves are not called seed-leaves, although they also are leaves of the seed-plantlet, but from their resemblance to a little plume, they, with the growing point between them, are together called the *plumule*. There are two leaves then in the one plumule.

It is clear that the seed of a bean is made up of two parts—the *seed-coat* and the *seed-plantlet* which fills the seed-coat, and that the seed-plantlet is made up of *four* leaves and the *axis* to which they are attached. We call the axis—as it appears before germination—the *stemlet*, because it bears the four leaves, and the free end of it has not yet developed into an evident root.

In a former experiment we found a carbohydrate (starch) and a proteid (legumin) in a bean seed. These two substances must be mainly stored up in the thick seed-leaves of the seed-plantlet. This would seem to account for the rapid growth of the plantlet at first.

Set out some of the germinating beans in a good soil in flower-pots or boxes. Keep them warm and moist and watch their continued growth. Also plant some dry beans.

Examine a soaked grain of corn as you did the bean. Remove the little body lying in one side of the grain—the body which you know as the *germ*. It is harder than the rest of the soaked

grain, not having absorbed water so freely. Compare it with the young corn plant you obtained by germination.

It will soon appear that this germ is a little corn plant. The slender, straight, stem-like part which lies in the middle of the flatter side of the germ is the *axis* or *stemlet*. The top end of the stemlet is the plumule, which you will see soon produces foliage-leaves, while from the lower end of the stemlet the root strikes out. The broad, fleshy part of the germ, in the face of which the stemlet lies, must be the *seed-leaf*, and corresponds to one of the thick leaves of the bean seed-plantlet.

The seed-plantlet of Indian corn has but one seed-leaf, and its plumule shows at first no distinct leaves to correspond with the two leaves of the bean plumule. In the bean, the seed-plantlet fills the seed-coat, so there is no food stored in the seed outside of the seed-plantlet; but in the grain of corn the seed-plantlet occupies only the smaller part of the grain. Examine the large mass of stored food which occupies the interior of the grain outside of the germ or seed-plantlet. In the case of the bean, the food was stored in the two fleshy leaves of the plantlet itself, but in the corn most of the food is outside of the seed-plantlet.

You will recollect that we found some time ago that the germ of Indian corn contains much oil. This is food stored up in the plantlet.

P
and
for
T
that
then
diffi
plac
tion
coa
to s
C
of t
the
whi
arra
one
F
per
par
pla
out
nov
the

I
of t
lett
sch

Plant grains of corn in pots or boxes of earth, and follow the development of the young plants for several weeks.

The seeds of clover, turnips, etc., are so small that we cannot see plainly the little plants in them, though we believe they are there. This difficulty is easy to overcome. You have only to place the seeds in conditions favorable to germination, when the seed-plantlets will burst the seed-coats, and will soon be sufficiently large for you to see them and their organs quite plainly.

Compare these little seed-plantlets with those of the bean and the Indian corn, and note whether they have one or two seed-leaves; also observe in which of the seed-plantlets the new leaves are arranged in pairs, and in which they are alternate, one above another.

From these studies we must conclude that every perfect seed contains a little plant and that the parent plant lays up a store of food for the seed-plantlet, either in the plantlet itself or in the seed outside of the plantlet, or in both situations. It is now plain that it is not the seed which grows but the little plant within the seed.

EXERCISES

1. Grow in pots or shallow boxes, from tested seeds, some of the common garden plants, such as tomatoes, cabbages, lettuce, cucumbers, pansies, asters, etc., to be set out in the school or home garden.

2. Place some potato tubers in a warm closet or box (to represent a cellar); others in a warm room exposed to the sunlight. In two or three weeks inspect them, and decide from the results which is the better way of sprouting potatoes for early planting.

XXV. THE SEASONAL CHANGES OF SPRING— SPRING CALENDAR

As soon as the first returning bird appears you should begin a Nature Calendar for spring. In it record the various events and changes which mark the approach and progress of spring.

The birds and early flowers of spring will be especially attractive to nearly everyone. In early spring many birds frequent the trees and fields near our homes for a while before they set up housekeeping in woods and retired places.

In many parts of the country the groves and forests are veritable flower gardens during the greater part of the month of May. Any one who has any appreciation of natural beauty should delight to learn something of the habits of these wild plants of spring, and find out their names. I hope, however, you will not pull them up ruthlessly, but spare them to beautify the earth for succeeding generations. I am moved to remind you of this, because already in some districts—especially in the vicinity of towns and villages—

all these beautiful plants have been practically exterminated.

I will enumerate here some of the features of the spring-time which are worthy of notice and of record in your calendar: The change in length of the shadow of some definite object—to be recorded once every few weeks at the same hour of the day; the temperature of the air at a certain hour—entered once a week; the length of the day (from sunrise to sunset) as recorded in the almanac—once a week; the disappearance of snow from the fields and ice from the streams; sudden changes of weather; the first appearance of different species of migratory birds, the dates of their nesting, and the period of hatching; the time when sap begins to run in the trees, and the buds to swell; the dates of the blossoming and leafing of the trees and shrubs in woods and orchards; the blooming of early spring flowers; the dates of sowing the different garden and field seeds, and the first appearance of the plants above ground; what kinds of plants suffered from spring frost, with dates.

EXERCISES

1. How much longer is the time of daylight (from sunrise to sunset) on June 1st than on April 1st?
2. How much longer or shorter is your shadow at noon on June 21st than on March 21st? Account for the fact.
3. How do you explain the gradual rise in the temperature during the spring months?

4. How is it that the buds of trees and the early flowering plants can develop so rapidly in spring, while the soil is yet quite cold?

5. What trees or shrubs were in bloom on the day you sowed your first carrots, beets, peas, corn?

6. What trees in your neighborhood blossom before their leaves expand?

7. Find one or more trees (or shrubs) in which the pollen-bearing flowers (staminate flowers) and the seed-bearing flowers (pistillate flowers) are in separate clusters on the same tree, and one or more in which they are in separate clusters on separate trees.

8. Find, by observation, when the trees are in bloom, whether their blossoms are pollinated by insects, or whether trees depend on the wind to convey pollen from the stamens to the pistils.

XXVI. THE SCHOOL GARDEN

School gardening is gradually becoming a very useful feature of school life. It affords an agreeable change from the book and desk work which prevails throughout the cold months. The knowledge and training to be gained in the school garden is certainly no less healthy and useful than the results of the indoor studies. So I hope your school, if it is not already provided with a school garden, will make a beginning this spring, if only with a small plot a few square feet in area.

As soon as the soil is dry enough, have it thoroughly cultivated with plough and harrow, or else with a spade and rake. A sufficient quantity

of go
same

other

If

shoul

Four

singl

but i

unde

at le

plots

Fl

plots

be gr

arrar

flowe

of th

arrar

shou

and

As

abov

near

pare

Th

nece

the s

of so

shou

of good old manure should be worked in at the same time, and the rootstocks of couch-grass and other weeds carefully removed.

If the garden area is large enough, the ground should be laid out in plots upon some definite plan. Four feet by eight or ten feet is a good size for single plots to be cultivated by individual pupils; but if the space is quite limited, several pupils may undertake the joint cultivation of one plot. Walks at least two feet wide should be left between the plots.

Flower seeds may be sown at the ends of the plots with vegetables between, or the flowers may be grown in separate plots, with the vegetable plots arranged symmetrically about them. Perennial flowering plants may be grown along the borders of the garden, or in central or corner plots. The arrangement of the plots and plants, however, should be determined by the tastes of the gardeners, and the size and shape of the ground.

As a rule, the plots should not be raised much above the level of the walks. The soil, particularly near the borders of the plots, does not become so parched during drought under level culture.

The catalogues issued by seedsmen will give the necessary information as to the time for sowing the seeds of different plants, the depth and distance of sowing, and so forth. The larger seeds as a rule should be covered more deeply than small ones.

The very smallest ones may be sown on the surface, and thinly covered by fine soil sifted over them by hand.

The soil immediately above the seeds, but not between the rows, may be pressed down with a narrow board or with the back of a hoe. This brings the soil into close contact with the seeds, so that they can draw moisture from it more readily.

Soon after the garden seeds are sown, wild plants—weeds—will begin to appear, perhaps before the seeds you sowed have germinated. These weeds, if allowed to grow, will rob the garden plants of food and water, cut off much of the sunlight and hinder the circulation of the air. You can easily show the effect of weeds by allowing them to grow in a small plot in which garden seeds have been planted.

The weeds are easily kept down if they are never allowed to make much headway. Go over the soil between the rows often with a hoe or rake. This frequent cultivation will root up the weeds that have come up, and bring many that are just germinating to the surface, where they will dry up and die. If the spaces between the rows are as wide as a narrow garden rake, or wider, the soil between the rows can be cultivated very rapidly with a rake to the depth of two or three inches. Some of the weeds in the rows may be taken out

with
rem
T
apar
vege
and
may
plan
T
serv
killi
form
wat
keep
and
W
the
fast
very
wan
thei
plot
Con
thos
try
hinc
belc
T
pur

with a hoe or a weeder, but some of them must be removed by hand.

Thin the garden plants out to the proper distance apart as soon as they are large enough. Some vegetables may be only partially thinned at first, and when large enough for table use, part of them may be taken for food, leaving the intermediate plants to grow on.

The frequent stirring of the soil with hoe or rake serves another purpose quite as important as the killing of the weeds. The loose layer of earth formed by raking or hoeing the soil hinders the water from escaping from the soil underneath, and keeps it there to be absorbed by the tiny rootlets and root-hairs of the plants.

Were it not for the loose earth mulch formed by the rake, the water would evaporate into the air so fast that the soil about the roots would become very dry and the plants would suffer greatly from want of water, and of course would be retarded in their growth. To demonstrate this, keep a small plot free from weeds, but do not cultivate it at all. Compare the growth of the plants in this plot with those in a well-cultivated plot close by. We will try to explain later how the loose earth mulch hinders the water from evaporating from the soil below.

The stirring of the surface soil answers the same purpose as watering, so that we may be said to

water the garden with the hoe or rake. Indeed, if we stir the surface once or twice a week, there will be little or no need for watering, unless the weather is exceedingly dry.

If any of the seeds fail to grow, sow others in their places. If early vegetables are used before midsummer, a second crop may be grown on the same ground; in this way all the available area will be occupied throughout the season.

If any of your plants are attacked by insects or diseases, try to find by inquiry or by consulting books or agricultural bulletins the proper remedies, and apply them in good time. Above all, keep your garden free from weeds to the very last.

If you thus tend your garden during the spring months, and arrange for its cultivation during the summer vacation, you will be surprised and fully rewarded to see how the plants have responded to your care—each kind in its own way. Your garden before summer has ended will be a mass of verdure and bloom, delightful to look upon. You may gather from your plot fresh juicy vegetables for the home table or that of a neighbor who has no garden, and flowers for a friend or for a poor invalid who would be helped by your sympathy expressed in this practical way.

In the autumn, after the crop has been removed, the garden should be manured, and either ploughed or spaded to a sufficient depth.

Wi
scho
even
your
Mue
done
chea
and
the
ways
gard
may
ties
mois

XXI

(For

Ma
whol
soluti
stalks
a cell

In
a fe
whic
since

Window and Flower-Pot Gardening. In case your school has no ground available for a garden, not even for a class plot, you will have to confine yourselves to window and flower-pot gardening. Much interesting and instructive work can be done in window boxes, or in flower-pots set on cheap stands. Bulbs and other flowering plants and ferns may be grown, and will add much to the attractiveness of the school-room and hallways. Specimens of grains and of the common garden vegetables should be grown also. Much may be learned about their habits and capabilities by varying the conditions of light, heat and moisture.

XXVI. THE MAKING AND TRANSFERENCE OF STARCH IN PLANTS

(For a bright warm day in the latter part of May or in June)

Material.—Leaves from growing shoots, some green, some wholly or partly white, Fehling's solution if available, iodine solution, test tubes or enamelled cups, spirit lamps, fresh stalks of grass, potatoes with long white shoots sprouted in a cellar or in a dark box.

In the afternoon, shortly before sunset, gather a few green leaves from rapidly growing plants which have been exposed to the light of the sun since morning. Nasturtium and Sweet Pea leaves

answer well for the following experiments, but you should try others also. Boil the leaves in water at once, and soak them in ordinary alcohol till the leaf-green is nearly or quite extracted. You may heat the alcohol to hasten the process, but if you do, be careful not to set it on fire. The leaf will gradually become nearly white.

Pour off the alcohol and cover the leaves with iodine solution. If the leaves turn blue or blue-black in color you must infer that they contain starch, and this is the result you will obtain if you perform the experiment at the proper time, and in the right way. Repeat the experiment if your results are not decisive.

Collect early in the morning some leaves from the same plants, and keep them in a dark box or closet; or better, cover the whole plant with a box till later in the day when you are ready for the next experiment. Then treat the leaves just as you did those which were gathered in the evening. You should find that they do not turn blue, as did the other leaves.

These leaves, like the others, no doubt contained plenty of starch in the evening before you gathered them. It must be, then, that the green leaves make starch in the daylight, and that the starch disappears from them in the darkness.

Find a leaf which is wholly or in part white, and test it for starch after boiling it in water.

You
ligh
of
sta
gre
N
the
tha
org
for
A
lea
in
bee
org
tha
or
wit
wh
sta
pa
I
Su
col
in
the
the
of
th

You must conclude that both leaf-green and light, as well as the heat required for the activity of the plant, are necessary for the making of starch in leaves, and presumably in the other green parts of plants.

Now we have found that starch disappears from the leaves in the night. We have shown also that starch is stored up in tubers, seeds and other organs. Indeed, starch appears to be the principal form in which carbohydrates are stored as food.

As the parts in which it is stored are devoid of leaf-green, the starch could not have been made in the organs in which it is stored. It must have been transferred from the leaves to the storage organs; but we found when we analyzed a potato that the starch was not soluble in the watery sap or juice. It is clear, then, that the starch made within the leaves must be changed into some form which will dissolve in cold water, for the solid starch could not pass through the plant from one part to another.

Starch is a carbohydrate insoluble in cold water. Sugar is a carbohydrate which dissolves readily in cold water. Now we find that sugar is present in green plants where growth is going on. In the spring, when growth is about to begin in trees, the sap is sweet with sugar. Pull a growing stalk of grass in two; chew the tender white part of the stem where growth is taking place. Test the

sprouts of a potato with iodine solution and with Fehling's solution, if available. The sprouts may be cut into small pieces and boiled in water, and the liquid poured off and tested as in previous experiments. You may find sugar present. The material for making the sugar came out of the tuber. These with other facts which you can easily discover, point strongly to the conclusion that the starch formed in the leaves is transported from them to other parts of the plant in the form of sugar.

If the sugar is not used it may turn into starch again, as when starch made in the leaves of the potato plant is conveyed down the stalks in the form of sugar into the tubers, where it is reconverted into starch, which forms about 80 per cent. of the dry matter of a potato tuber.

If you leave some tubers in a dark box, little tubers will be formed on the white stems. If you test these little tubers for starch you will find a good proof that sugar can be changed into starch by plants.

EXERCISES

1. Write out in your own words an argument to prove that green leaves make starch in the day-time.
2. Argue that a plant, or at least some plants, can change starch into sugar.
3. Give proofs that sugar can be changed back into starch in a plant.

XXV

M
bottle
napp
grow
of w

W
who
not
sho

H
push
a lit
mou
mou
the
tain
oxy
carb
on

R
till
bott
plan
tan
as t
its

XXVIII. WHAT PLANTS MAKE STARCH OUT OF

(For a bright day late in May or in June)

Material.—Several wide-mouthed bottles, such as pickle-bottles or milk-bottles, a pail of water, saucers or glass nappies, tapers or candles, fresh leafy shoots from rapidly growing plants, a potted plant which has wilted for lack of water.

Water thoroughly the roots of a potted plant whose leaves have wilted for lack of water. Do not put any water on the leaves. Also set some shoots with wilted leaves in a vessel of water.

Hold a wide-mouthed bottle mouth down, and push a burning taper or a small candle up into it a little way. When the flame dies out, cover the mouth of the bottle with your hand. Turn it mouth up, and shake a little lime-water through the gas in the bottle. Evidently the candle contains carbon which in burning unites with the oxygen of the air in the bottle to form enough carbonic acid gas to produce the observed effect on the lime-water.

Rinse the bottle and burn the taper in it again till the flame is extinguished. Put up into the bottle a leafy shoot from an actively growing plant. Push the burning candle up a short distance into the bottle beside the shoot, and, as soon as the flame dies out, promptly stand the bottle with its mouth down in a dish which contains enough

water to seal the mouth of the bottle and keep the gas inside from mixing with the air outside.

Prepare two other bottles in exactly the same manner. Set two of these bottles, with the dishes in which they stand, in or close to a sunny window, and set the other in a closet, or cover it with a box, to shut out the light.

Burn a taper in a fourth bottle till the flame dies out for lack of oxygen, and set this bottle mouth down in a dish of water, but do not put a leafy shoot into it. Set this bottle also in a sunny window. All these things should be done in the forenoon as early as convenient.

Before school closes in the afternoon, finish the experiments begun in the morning. Take one of the bottles set in the sunlight with a leafy shoot in it, dish and all, and lower the dish and bottle into a pail of water. Let the dish sink. Put your hand down into the pail of water and pull the leafy shoot down out of the bottle, taking care not to allow any air to enter the bottle. Cover the mouth of the bottle with your hand, raise it out of the water, turn its mouth up, and shake lime-water through it.

If you have performed the experiment successfully you will be forced to conclude that the carbon dioxide, which was produced in the bottle by burning the taper in it, must have been taken up or absorbed by something.

Place the bottle which had no plant in it with its mouth in the pail of water. Let the dish drop, turn the bottle mouth up with your hand upon its mouth, and shake lime-water up and down through it. The lime-water will become milky in appearance. You can now show whether it was the leafy shoot in the first bottle or the water which took up the carbonic acid gas.

Take the plant out of the other bottle which was set in the light. In doing so, proceed as with the first, so as to admit no air. Raise it till its mouth is out of the pail and quickly try to burn the taper in it. Recollect that the taper would not burn in it when you set it in the sunlight. When the taper ceases to burn, shake lime-water through again. How do you explain the result of this experiment?

We turn next to the bottle set in darkness. Get the leafy shoot out of it as you did out of the others, and test the gas in the bottle with lime-water. The result will show whether the leaves in this bottle took up the carbonic acid gas.

Let us now try to interpret all the facts brought out in these experiments. It seems that green leaves on a growing shoot take in during the daytime carbonic acid gas from the air around them, but that this process ceases when the plant is in darkness, that is, in the night.

Think of this in connection with our previous

conclusion, that green leaves make starch in the day-time, but not at night. It seems that the leaves are absorbing carbon dioxide at the same time that they are making starch, and at night when they are not making starch they cease to absorb carbon dioxide. In other words, the demand for carbon dioxide ceases when the starch-making ceases.

This looks as though the carbon dioxide is used in making the starch, and this might well be, for carbon dioxide contains carbon, and starch consists of carbon and water. The carbon dioxide might yield the carbon necessary to produce starch, but it contains no water. The water for starch-making must be obtained from some other source.

Look at the plants whose roots we watered this morning, and the shoots whose leaves were withered. Probably by this time the limp, helpless-looking leaves have straightened up, and are now quite firm and vigorous in appearance. We know that there is water in the juice of leaves; but the water applied to the roots could certainly not make the leaves firm and plump again unless it had ascended the stem and footstalks and entered the blades of the leaves.

If leaves take in any water at all *from the air*, it cannot be much, for it does not keep the leaves from wilting; but if water be applied to the roots it soon restores the wilted leaves. This shows

why
hairs
that
could

We
carbo
taken
that
up th
trem
out o
unite
rootle
the l

Re
close
the s
but c
oxyge
and r
consi
and v

Th
bottle
sever
were
off th
they
The l

why the rootlets require root-hairs. The root-hairs have such thin walls, and are so numerous, that they must absorb water faster than rootlets could.

We have just argued that leaves obtain the carbon for starch-making from the carbon dioxide taken in during the day-time, and now we see that leaves obtain much water which is carried up the stem to them from the roots. It is extremely likely, then, that green leaves make starch out of the carbon of carbonic acid gas, chemically united with water which was absorbed by the rootlets and root-hairs, and ascended the stem to the leaves.

Recollect that when you heated starch in a closed tube, you obtained carbon and water from the starch. The leaves do not take in free carbon, but carbon dioxide, which consists of carbon and oxygen. They only need the carbon of this gas and not its oxygen in making starch, since starch consists of carbon and water, not of carbon dioxide and water.

This explains why the taper would burn in the bottle in which the leafy shoot had been left for several daylight hours. The leaves, while they were making starch in the sunlight, were giving off the oxygen of the carbon dioxide, from which they were using the carbon in starch-making. The leaves then must break up the carbon dioxide,

for they use its carbon in making starch, and set its oxygen free. The oxygen, or part of it, must be exhaled from the leaves in the sunlight, else the taper would not have burned in the bottle afterward.

We have seen that the starch in plants changes into sugar, so we may say that plants form sugar as well as starch from carbon dioxide and water. Finally we may claim that wood, which is the most lasting of the three carbohydrates we have found in plants, is produced from the same materials as the other two. It is evident that plants make for themselves all the starch, sugar and wood they contain, for neither the soil nor the air contains either of these substances. When we consider what a large amount of wood one large tree contains, it astonishes us that this one plant should have been able to produce enough starch or sugar to form such an immense weight of wood.

EXERCISES

1. Write out in your own words your reasons for believing that green leaves use carbonic acid gas and water in making starch.
2. Point out whether it is correct to say that a commercial starch factory *makes* starch. What is the fact?
3. Show why trees and other plants need such an immense spread of leaf surface.

Mat
contai
lime-w

So
their
each
by re
the s
leave
that c

Pu
into
prese
pose-
peas
of pe
peas.
it in
advan

of th
seed-
at on
the b

Th
breat
mate
the c

XXIX. THE BREATHING OF PLANTS

Material.—Peas and sunflower seeds or other seeds which contain large seed-plantlets, wide-mouthed bottles, large corks, lime-water.

Soak a sufficient quantity of peas in water until their coats are easy to remove. As peas are seeds, each should contain a little plant. Confirm this by removing the seed-coat. How many leaves has the seed-plantlet of the pea? How many seed-leaves? Although this seed-plantlet is much like that of the bean you will notice some differences.

Put a little cotton wool drenched with water into a wide-mouthed bottle—a six-ounce (6 oz.) prescription bottle will answer well for this purpose—and cover the cotton with a layer of soaked peas about half an inch deep. Cover the layer of peas with wet cotton, and add another layer of peas. Cork the bottle nearly air-tight, and keep it in a warm place till the seed-plantlets have advanced in germination so far that the root-ends of the stemlets extend a short distance outside the seed-coats, or until the flame of a match will be at once extinguished when held in the mouth of the bottle.

The young plants are now active, and should be breathing if they ever breathe. Plunge a burning match into a wide-mouthed bottle of air. Remove the cork and plunge the burning match into the

gas above the germinating peas, and immediately cork the bottle again. Then pour a little lime-water in upon the peas, place your hand tightly upon the mouth of the bottle and shake the lime-water up and down through the gas in the bottle. The lime-water should become quite milky in appearance.

To interpret these facts we can only say that the little pea plants must be generating carbonic acid gas, and giving it off into the air. Other seeds besides peas—sunflower seeds for instance—should be used for this experiment, at the same time, in order to confirm the results obtained with the peas.

Blow your breath through lime-water till it turns milky. Carbonic acid gas is being generated in your body and given off into the air. You call this process, in yourself and animals generally, breathing or respiration. The similar process in plants is called vegetable breathing or respiration.

It is plain that the little pea plants do not get all this carbonic acid gas from the air in the bottle, else it would whiten lime-water before the peas are put in. Just as we need oxygen *from the air* to unite with the carbon in our bodies to produce the carbonic acid gas we exhale in breathing, so the plants need oxygen from the air for the same purpose. It is this oxidation of carbon in our bodies—as you have learned—that keeps our

bodie
but i
do, an
as it
not b

1. I
mouth
its mo
outsid
a box,
severa
bottle
upwar
Draw

2. I
whole:

N.B
plants
occupa
quanti

3. I
tion—
for se
ence i

bodies warm—warmer than the surrounding air; but if plants breathe much more slowly than we do, and the heat produced passes off about as fast as it is generated, the bodies of plants should not be as warm as ours. Feel a plant and see.

EXERCISES

1. Push one or two growing leafy shoots into a wide-mouthed bottle, held mouth down, and set the bottle with its mouth in a dish containing enough water to prevent the outside air from entering the bottle. Cover the bottle with a box, or set it in a dark closet, and leave it in darkness for several hours. Then remove the shoot with the mouth of the bottle under water. Raise the bottle quickly, turn it mouth upward, and shake lime-water up and down through it. Draw the conclusion.

2. Is there any reason for the belief that plants are unwholesome in a bedroom at night?

N.B.—The quantity of carbon dioxide given off by a few house-plants is so small compared with what is given off by the human occupant of the room that the danger from the plants is a negligible quantity.

3. Repeat the experiment in Exercise 1, with one variation—keep the bottle containing the leafy shoot in the light for several hours, instead of in darkness. Explain the difference in the results.

XXX. THE TRANSPIRATION OF WATER BY PLANTS.

Material.—Test tubes, cotton wool, potted plants in active growth.

Set a potted coleus, or some other plant with rather large leaves, in a warm room. Roll the blade of one of its leaves into a cylindrical form, and push it into a test tube without injuring the leaf-stalk or breaking it off from the stem of the plant. Then pack the mouth of the tube around the footstalk of the leaf with cotton wool, taking care not to crush the footstalk. The cotton will thus answer as a cork, and but little moisture can escape from the test tube. Let the tube incline so that a liquid would flow toward the bottom, and support it in that position so that its weight will not break or injure the leaf-stalk, and cut off communication between the blade of the leaf and the stem and root of the plant. In a short time a clear liquid will collect in drops on the inside of the test tube.

Supply the plant with water by keeping the soil fairly moist, and in a few days a considerable quantity of the liquid will have collected at the bottom of the tube. Remove the cotton stopper and the leaf from the tube, and test the liquid.

It is clear that the leaf must have been giving

off w
see t
escap
persp
you
drops

Th
is ca
of pe
will
nearl
plant

Th
from
be v

W
stare
living
that
rapid
the l
supp
very
leave
giving
on th
proof

TH
off i

off water from its blade; but why could you not see the water escaping from the leaf? It must escape in the invisible form of steam, just as perspiration from your body is invisible unless you exert yourself so actively that it collects in drops of sweat.

The giving off of water by the leaves of plants is called transpiration. It resembles the process of perspiration in yourselves; but if you try, you will find that the drops of perspiration are not nearly as pure water as the water transpired by plants.

The amount of water exhaled in one season from a field of corn or from a large forest must be very great. How is the supply kept up?

We have seen that plants need water for making starch, sugar and wood, that while they are living they contain free water—in their sap—and that they exhale water from their leaves quite rapidly in transpiration. It is plain that while the leaves are on the plants they must be regularly supplied with water, else they would soon become very dry. But this water is not absorbed by their leaves, for we find that the leaves are constantly giving off water instead of taking it in. The bark on the stems and roots of plants is nearly water-proof, and keeps the plants from drying out.

The water used by plants, and that which passes off in transpiration, must be taken in by the thin-

skinned rootlets and by the root-hairs which the rootlets bear in such vast numbers. As a striking evidence of this, allow a low plant, such as a primrose growing in a pot, to become so dry that the leaves are all wilted. Set the pot in a shallow vessel of water, and observe how quickly the water will reach the leaves from the roots and the root-hairs buried in the soil.

To prove that the root-hairs really do spread from the rootlets into the soil in all directions, grow from the seed a few small plants in a pot of light soil. Empty the soil out in a mass when dry, and carefully take the plants out of the soil. You will find many particles of soil clinging to the rootlets by means of the root-hairs, to which the grains adhere.

I.
Ma
 stems
 flowe
 knife
 Cu
 pith
 mag
 appe
 very
 but
 then
 In
 mag
 and
 char
 thos
 the
 O
 can
 pith

SECOND YEAR

AUTUMN LESSONS

I. THE CELLULAR STRUCTURE OF PLANTS

Material.—Specimens of sunflower stalks and of other stems, fresh green leaves, germinating plants with root-hairs, flowers discharging pollen, a cheap magnifying glass, a sharp knife.

CUT with a sharp knife a thin section from the pith of a sunflower stalk and examine it under a magnifying glass. You will conclude from its appearance under the glass that it is made up of very minute parts, empty or with nothing in them but air, and with thin walls or partitions separating them.

Indeed, if the piece of pith were sufficiently magnified it would look much like a honey-comb; and just as we give the name of cells to the little chambers which make a honey-comb, so we call those of the pith by the same name. The *cells* of the pith, however, are many times smaller.

Of course the hard woody part of the stem cannot be composed of such cells as those of the pith. If you scrape the wood with your knife-

blade you will find that it will split lengthwise into very fine threads or fibres. The finest fibres of the wood are also called cells, for they too are little chambers comparatively long and very narrow, so that they resemble slender tubes closed at the end.

There are many forms of cells in plants. If you were to examine the skin of a leaf under a compound microscope, you could see the cells of which it is composed, and you would find that the pulp cells of the leaf resemble somewhat those of the pith of a sunflower, but in the living leaf these cells contain water and various other substances—some dissolved in the water and some not. By scraping and splitting one of the veins of the leaf with your knife you can find of what kind of cells the veins are composed.

You can now see that a plant—even a great tree—is a mass of cells of various sizes and shapes, too small and too close together to be seen separately except with a microscope, and all stuck together by the walls or partitions which bound them. You may picture out in your mind how a plant would look if your eyes were piercing and powerful enough to see through it, and at the same time see the many millions of cells of which it is built up.

You remember the root-hairs which you saw some time ago. Each of these hairs is a slender

tube,
exten
rootle
there
which
cell i
the v
it is
root-
ing g
A
arran
thus
of a
veins
The
are
near
form
is lar
exten
not
the p
the
cells
lose
wall
or th
T

tube, closed at the tip, with a very thin wall extending out from a cell in the skin of the rootlet. A root-hair is only a part of a cell, for there is no wall separating it from the cell from which it sprang. You cannot see the part of the cell in the skin of the rootlet. It is very small, and the wall which separates it from the cells about it is too thin to be perceived by you; but the root-hair itself can be plainly seen with a magnifying glass.

A material which is made up of a set of cells arranged together in one system is called a *tissue*; thus pith is one of the tissues of a plant, the pulp of a leaf is a tissue, the skin is a tissue, and the veins of the leaf are composed of woody tissue. The substance of which the cell-walls of a plant are mainly formed is called *cellulose*. Cotton is nearly pure cellulose, the fibres of cotton being formed of long narrow cells. The wood of trees is largely cellulose, for it too is made up to a great extent of thickened cell-walls. Although pith is not called woody tissue, yet the cellulose walls of the pith cells are nearly the same as the wood of the firmer tissues. Even the thin walls of the cells in the pulp of a leaf are composed of cellulose. So a plant-cell is a minute chamber with a wall of cellulose, which may be very thin and soft, or thickened and more or less rigid.

The little plants which we sprouted were made

up of cells, but these cells must have been alive, else the plant could not have grown and could not be killed. Yes, every living plant-cell must have some living substance inside its wooden (cellulose) wall. Of course the sap which we squeeze out of the cells is not alive, nor is the leaf-green alive, for the uncolored parts of a young plant are alive and grow. But microscopists find in every active cell a soft, glairy, colorless substance (resembling the "white" of a raw egg) which is not present in old dead cells.

This is the living substance of the cells, and is the only living substance in a plant. It is called *protoplasm*. You cannot expect to see it with the naked eye, or with a common magnifying glass, for there is only a little of it in each living cell, and you know how small a cell is.

Are the cells dead in dry garden seeds? No, else the seeds could not germinate. The protoplasm in the cells of the seed-plantlet before germination must be dormant or in a resting state, yet capable of being stimulated into active life. That is what the warmth and the moisture do.

We can now understand how a plant grows. A plant is made up of minute cells, so when it is growing the number of these cells must be increasing. New cells are being formed from the older ones. This does not mean that the older

ones
grow
a cel
of th
pare
Of
ones
ceas
now
were
livin
W
ther
bein
gets
mea
as it
I
tissu
the
The
from
a flo
a tis
W
of a
divi
tube
The

ones are destroyed, but each of the cells in the growing part of the plant becomes two cells, by a cellulose wall forming across the middle. Each of these two cells soon becomes as large as the parent cell which produced them.

Of course dead cells cannot divide to form new ones, nor do cells necessarily die as soon as they cease dividing; but certainly all the dead cells now in a plant were once alive, for when they were formed from their parent cells they had living protoplasm in them.

Whenever any part of a plant begins to grow, there cell division is going on and new cells are being formed from the old ones. When a plant gets to be twice as large and heavy as it was, that means that it contains about twice as many cells as it did.

I should remind you that cells do not form a tissue unless they are joined together. Examine the pollen of a flower with a magnifying glass. The little grains of pollen as they are discharged from the anther are *separate* cells. The pollen of a flower, then, although made up of cells, is not a tissue.

When a grain of pollen germinates on the stigma of a flower, a *germ-cell* formed by the *internal* division of the pollen grain descends the pollen tube which penetrates an ovule (unfertilized seed). The ovule contains another germ-cell of a different

sort, and here (in the ovule) the two germ-cells unite to form one new cell, called the *egg-cell*. The union or fusion of the two germ-cells is called *fertilization*. The egg-cell thus formed soon begins to divide, and cell-division continues till the egg-cell has developed into the seed-plantlet (embryo); after resting for a time, the seed-plantlet, when placed under suitable conditions, germinates, and develops into a flowering plant. So we see that every *flowering* plant begins its career as a single cell—an egg-cell—which was formed by the fusion of two other cells.

II. THE COURSE OF THE SAP IN PLANTS

Material.—Sunflower leaves or other leaves with stout footstalks, stems of Indian corn and of the sunflower, carrots, potatoes, short leafy branches, some young plants growing in light soil, red ink or other red dye, black ink, tumblers and wide-mouthed-bottles, shallow dishes.

Set a few fresh leaves with large footstalks, such as sunflower leaves, in a bottle or tumbler containing red ink slightly diluted with water. Cut a few pieces two or three inches in length from the stems of sunflower and of Indian corn, stand them in a shallow dish containing diluted red ink about half an inch deep, and take an occasional look in expectation of results.

If this experiment is started in the forenoon, in the afternoon you will be able to tell through which of the tissues of the stems and leaves the ink rises, and to calculate at what rate per hour it ascended the stems. Since red ink is a solution of dye in water, this experiment will show whether substances dissolved in soil water might ascend the stems dissolved in the water absorbed by the root-hairs and rootlets.

Examine the leaves after several hours, to see whether the dye remains in the tissue through which it ascended, or whether it diffuses into the other tissues.

Stand some pieces of sunflower and corn stalks, with the top end down, in red ink, and note whether the ink will travel through the stem in the opposite direction, that is, toward the root.

Cut both ends off a short carrot and a potato, and set them in a shallow dish containing ink in the bottom. Use black ink for the carrot. Interpret the results.

Set short leafy branches of poplar or of another tree in a wide-mouthed bottle or glass jar half full of a solution of red ink or of other red dye, to find whether the dye will pass with the water from the stem into the leaves. Peel the bark off the stem for the distance of one-half an inch a little above the level of the solution, and note whether the water and dye can ascend to the leaves through

the part of the stem from which the bark was removed.

We have seen that if we supply water to the roots of a plant whose leaves are wilted, the water will soon ascend and fill the cells so tightly that the leaves stiffen and straighten out again. To show that most of this water is probably absorbed by the root-hairs, grow from seed, in light soil, a few plants to the height of two or three inches. Turn the soil out of the pot, and carefully take the plants out of it. You will find that much soil clings to the rootlets by means of the root-hairs which adhere closely to the particles of soil.

It is clear that the water which ascends the stems of plants must pass from the soil through the skin of the rootlets, or through the thin walls of the root-hairs. There are evidently no openings in the roots by which solid matter can be taken into the plant. Water and substances dissolved in it must soak through the thin walls of the cells and root-hairs.

Since the whole plant is composed of cells, the watery sap must ascend the stem and leaves by diffusion from cell to cell. Similarly, the starch made in the leaves when changed into sugar must pass through the stem from cell to cell, dissolved in the watery sap, to the other parts of the plant, to be used where needed, or to be stored up in tubers, bulbs, etc. We have seen that plants use

water
being
water
use of
sugar
plant
substa

III.

Mate
less pl
obtain

The
leaves
leaves
in the
root-l
leaves

The
be m
the d
footst
the w
includ
leaf.
stem

water in the *manufacture* of starch—the starch being composed of carbon and the elements of water chemically united. Here we find another use of the water in plants, for the transference of sugar and other substances from one part of the plant to another could not take place unless these substances were dissolved in the water of the sap.

III. FERNS AND OTHER GREEN FLOWERLESS PLANTS

Material.—Fresh specimens of ferns and other green flowerless plants, such as horsetails, club-mosses, mosses, and, if obtainable, pond-scums in water.

The green spreading *fronds* of ferns are evidently leaves, but where are the stems which bear these leaves? In our ferns the stems must be concealed in the earth below the fronds. These stems are root-like in appearance, but since they bear the leaves of the ferns they must be true stems.

The footstalks of the compound fronds might be mistaken for stems, but you will notice that the divisions of the fronds are not set on the footstalk like leaves on a stem, so we must regard the whole frond, no matter how much it is divided, including the stalk which supports it, as a single leaf. The roots will be found extending from the stem into the surrounding soil.

Upon the backs of some of the fronds may be seen organs quite different from any you have seen in the flowering plants. Since ferns have no flowers, we might assume that these are the organs of reproduction, and when we recollect that the seeds of flowering plants are borne by leaves (carpels) the assumption seems very probable.

Examine the dots (*fruit-dots*) on the backs of the fronds closely, and you will see that they are made up of little spherical bodies which become plainly visible if you use an ordinary magnifying glass. Fruit-dots resemble clusters of minute berries, partially concealed, in most ferns, by a thin membranous covering. The minute berry-like bodies which make a fruit-dot are called spore-cases because each one is filled with still more minute grains called spores; so a fruit-dot is a collection of spore-cases.

Rub a dry fruit-dot hard enough to burst the spore-cases, and you will obtain a powder the grains of which are so fine that you cannot make out their form without a microscope of considerable magnifying power. Every particle of this dust-like powder is a *spore*.

If you collect some mature spores which have been freely discharged from the spore-cases of a fern and scatter them on suitable soil where the conditions will be similar to those where ferns

grow
seen
and
In g
spore

Al
a see
duce
plant
spore
plant
small

Th
plant
the l
sea-w
by th
surro
no f
joint

at th
Th
cover
cases
bases
speci

Th
short
cases

grow naturally, you may have the pleasure of seeing the young ferns which grow from the spores, and of watching them develop their first fronds. In greenhouses, ferns are often grown from the spores.

Although a spore gives rise to a new plant as a seed does, yet it is not a seed. Seeds are produced by flowers, and each seed contains a seed-plantlet. A fern is a flowerless plant, and the spore from which it grows contains no minute plant (embryo) as a seed does. Spores too are smaller than seeds.

There are other families of green flowerless plants besides ferns. The principal of these are the horse-tails, club-mosses, mosses, and algae or sea-weeds. The horse-tails may be distinguished by their grooved and jointed stems, with a sheath surrounding the stem at each joint. They have no foliage-leaves, but some species bear slender, jointed branches. The spores are borne in a spike at the top of the stem.

The club-mosses have slender, flexible stems covered with numerous short leaves. Their spore-cases are crescent-shaped and occur singly at the bases of leaves—either the ordinary leaves or special leaves differing in form from the others.

The mosses too have leafy stems, often very short. The spores are produced in solitary spore-cases, usually borne on a slender leafless stalk.

Sea-weeds or algae are best developed in the sea—along the shores, and often far out from land. *Fresh-water algae* are common in ponds and slow streams. They often form soft, green, stringy masses, floating in the water. These fresh-water forms are called *pond-scums*.

EXERCISES

1. Make a collection of the most beautiful ferns, horse-tails, club-mosses and mosses you can find in your neighborhood. The plants may be dried between sheets of porous paper. Old newspapers answer the purpose well.
2. Find some pond-scums, take them to the school, and keep them in water for a while that all may observe them.

IV. MUSHROOMS

Material.—Specimens from the woods and fields of various forms of mushrooms, including gill-bearing and pore-bearing species.

Some forms of mushrooms are known to children as toadstools, others as puffballs. The common mushrooms we see growing on the ground, mostly in soil rich in humus (decaying vegetable matter), with their circular caps and erect stalks, resemble little umbrellas in form. If you examine the spreading caps, you will find the under side in some species divided into thin blade-like parts, with narrow spaces between the divisions. These divisions, which radiate from the centre, are called

gills ;
gill-b

Cu
room.
of w
other
lines
paper
powd
mush

We
is a s
the n
by d
stalk.

throu
veget

Ea
of r
part.

spaw
form
with

In
is pe
tubes
as th

Th
form

gills; and mushrooms which have them are called *gill-bearing* mushrooms.

Cut the stalk off a mature gill-bearing mushroom, place the cap, gills downward, on a piece of white paper, and cover it with a glass jar or other vessel, to prevent air currents. Before long, lines of very fine powder may be seen on the paper just below the slits between the gills. This powder is made up of the spores from which mushrooms grow, each spore being a single cell.

We see from this that the cap of the mushroom is a spore-bearing organ. The vegetative part of the mushroom is rarely observed; it may be found by digging into the earth about the base of the stalk. It is made up of threads which spread through the earth, drawing food from decaying vegetable matter in the soil.

Eatable mushrooms are grown by the cultivators of mushrooms from the underground vegetative part. It is sold under the name of mushroom *spawn*. The mushroom lives for a time in the form of spawn, then the spawn sends up a stalk with a cap on it for producing spores.

In some mushrooms the lower side of the cap is perforated with many small openings called *tubes* or *pores*, which answer the same purpose as the gills in other mushrooms.

The *pore-bearing* mushrooms are of different forms. Some species of them are common on

trees. They are often quite tough and sometimes hard, and resemble little shelves or brackets fastened to the tree. These are called bracket or shelf mushrooms.

The bracket, however, is only the spore-bearing part of the mushroom. Most of the mushroom—the vegetative part—is concealed within the tree upon which it may have been feeding for a long time. Upon splitting a log which has shelf mushrooms on it you can find the vegetative part of the mushrooms within, and observe the effect on the tree. These mushrooms destroy the wood of living trees and may finally kill them. Bracket mushrooms grow from spores which fall upon a wound in the tree, and, germinating there, grow into the tree.

Puffballs are neither gill-bearing nor pore-bearing mushrooms. The black powder which issues from the ripe ball is made up of a vast number of spores, each of which is capable of producing a new puffball.

Some mushrooms are good for food, but there are so many poisonous ones that it is not at all safe for inexperienced people to eat those of their own selection.

Mushrooms are usually white, but are sometimes brightly colored. They contain no leaf-green, and so we know that they must obtain their food from material prepared by other plants. Many of them

live on
soil;
trees,

A
plura

1.
woods
2. 1
3. 5
or from

Ma
lemon,
flower

Pla
with
lemon
respe
each.

place
order
warn

Pu
ately
jars,
in a p
boilin

live on the decaying bodies of plants buried in the soil; others, such as the bracket mushrooms of trees, obtain their nourishment from living plants.

A mushroom is often called a *fungus*. The plural of this word is *fungi* (pronounced fūn-jī).

EXERCISES

1. Make a collection of mushrooms from the fields and woods, noting at the same time where they flourish best.
2. Draw two or three mushrooms of different forms.
3. Try to grow some mushrooms from spawn or from spores, or from both.

V. MOULDS

Material.—Small pieces of bread, cheese, boiled potato, lemon, fresh leaves, glass jars (self-sealers), plates, tumblers, flower-pots or bowls.

Place a boiled potato, a piece of bread saturated with water, a dry piece of bread, a thick slice of lemon, some damp leaves, a piece of cheese, respectively, on plates and invert a tumbler over each. Prepare duplicates of some of these, and place a flower-pot or bowl over the tumbler in order to exclude the light. Set the whole in a warm place.

Put a boiled potato and a piece of bread separately in glass jars with air-tight covers. Place the jars, open, and their covers—rubber band and all—in a pan of cold water, and bring the water to the boiling point. Allow the water to boil for a while,

then quickly turn the jars with mouth obliquely downward, allow the water to drain out, and promptly put the covers on the jars before turning them mouth upward. Screw the cover down, and keep the jars in a warm place. Cover one of the jars to shut out the light.

Look from time to time to see whether any new growths appear on any of the substances under the tumblers or in the jars. Note whether the new growths are all alike, or whether they differ in form, color, or in other ways.

After a time you will see on some of the materials, perhaps on the bread, a beautiful white growth, apparently composed of fine fibres or threads. Soon very small round black bodies, resembling black pin-heads, will appear upon the white threads. These will probably increase greatly in number, until the whole mass is speckled with black. This white growth which bears the black specks is a *mould*, and the little black balls are full of fine powder.

You will probably find that no moulds have developed on the bread in the sealed jars, but if you sift upon it a little of the powder from the moulds under the tumblers, and cover the jars loosely, you should soon see an extensive growth of moulds. Try whether the moulds grow better when the jar is sealed tightly, or when the cover is left slightly loose.

Even
mould
single
mould

The
mould
mater
are bl

It is
grow
the br
they g
bread
may b
have
stance

Since
canno
starch
makir
make
the su
as gre
must
by gr

1. S
2. F
—in a

Every particle of the fine powder from which moulds grow is a spore. A mould spore is a single cell which is capable of developing into a mould plant.

The species of moulds just referred to is a black mould, but you will probably find on some of the materials moulds in which the spore-bearing organs are bluish in color. These are blue moulds.

It is evident, since the spores from which moulds grow are so small, that they must obtain food from the bread or other organic substances upon which they grow. You can verify this by examining the bread after the mould has ceased to grow. You may be able to see that the threads of the moulds have spread through the bread and other substances from which they were absorbing food.

Since moulds do not contain leaf-green, they cannot use carbonic acid gas and water to make starch and other carbohydrates, nor to help in making proteids. This means that moulds cannot make out of inorganic matter from the air and soil the substances of which their bodies are composed, as green plants can do. Like animals, these plants must use food which has been prepared for them by green plants.

EXERCISES

1. Show whether moulds are flowering or flowerless plants.
2. Find whether moulds grow better in light or in darkness—in a cold room or in a warm room.

3. Try whether moulds will grow on dry substances.
4. Explain how the moulds came to grow on the substances under the tumblers, although you had sowed no mould spores there.
5. How can mould spores be killed, and mould growth thus be prevented?
6. Heat a piece of boiled potato in a jar of boiling water, pour off the water, sprinkle dust from the floor on the potato, and cover the jar. Set the jar in a warm place, and account for the growth of moulds on it, if any appear.
7. Find whether mould spores are floating about in the air.

VI. YEASTS

Material.—A fresh cake of yeast, a cup of molasses, a little wheat flour, granulated sugar, lime-water, wide-mouthed bottles of different sizes, test tubes or homeopathic vials, a soda-water bottle, wooden test-sticks, a spirit lamp.

Stir up half of a fresh yeast cake in a tumbler of water. The other half of the cake, if needed, may be used in the following experiments. Mix in a large bottle half a cup of molasses with about seven or eight times its volume of water.

Make a small ball of dough—not too soft—by mixing a little wheat flour with water into which you have stirred yeast. Make two other balls of dough, using water without yeast in one, and some of the molasses solution with yeast in the other. Drop the three lumps of dough into three wide-mouthed bottles. The dough should occupy about one-third of each bottle.

Cork the bottles loosely and set them in a warm place (near a stove or a radiator) for several hours, until the dough expands in one or more of them to double its original volume. Try whether a match will burn in the mouth of each bottle. Test for carbonic acid gas by tipping the open mouth of each bottle over the mouth of another bottle containing a little lime-water, and then shaking the lime-water through the bottle. Close the bottle tightly with the hand while shaking the lime-water through it. Observe the smell given off by the risen dough.

Fill several test tubes or vials one-third full of molasses solution, add a few drops of the mixture of yeast and water to each, cork the tubes or vials, and set the whole in a warm place. Watch the action which soon sets in, and after some hours go through the motion of emptying the gas above the solution into a two-ounce bottle with one-third of an inch of lime-water in the bottom. Close the bottle and shake the lime-water through it.

If you do not get a decided result at first, repeat the experiment, using another tube or vial. Note the smell given off from the solutions containing the yeast.

Fill a pint or a half-pint bottle half full of a fairly sweet solution of granulated sugar (cane sugar), add a tablespoonful or two of the mixture of yeast and water to each. Cork the bottles, not

quite air-tight; set them in a warm place, and note and account for the results. The *beery* smell from one of the solutions is due to the presence of alcohol, formed by the action of the yeast. Try whether this beery smell is given off from the test tubes or vials containing molasses solution and yeast.

Put some of the frothy scum which collects on the molasses solution in which the yeast is working into another bottle containing a molasses solution. Keep the solution warm and explain the result.

Fill a soda-water bottle two-thirds full of molasses solution, add yeast, cork *tightly*, and leave the bottle in a warm place till the cork disappears. Explain this circumstance.

Boil a molasses solution containing yeast, and observe whether the yeast acts as before. Explain the result.

When yeast is studied under a microscope of considerable magnifying power, we find that it is made up of small cells, usually rounded in form, which multiply rapidly under favorable conditions by new cells budding off from the older ones. The new cells readily separate from the parent cells, and grow to be as large as they.

A yeast cake is just a mass of yeast cells stuck together. Each yeast cell is a minute plant.

Since yeasts contain no leaf-green, and live, like mushrooms and moulds, on material prepared by

other
and
yeast
Th
carbo
vinou

1. T
- of stan
2. I
3. (
- dough,
- two su
4. V
- by the
5. V
- dough
- making
6. V

(Look

Yo
feed
cause
has b
the p
largel

other plants, they are included with the moulds and mushrooms in the great group of *fungi*. A yeast is a budding fungus.

The action of yeast in producing alcohol and carbon dioxide from sugar is called alcoholic or vinous fermentation.

EXERCISES

1. Try whether yeast will live and multiply in a mixture of starch (raw or boiled) and water.
2. Find whether yeast will thrive in a cold place.
3. (a) What two substances are produced by yeast in dough, and in a molasses solution? (b) From what do these two substances seem to be produced?
4. What caused the cavities in the dough which was raised by the yeast? How can these cavities be made permanent?
5. What two substances are expelled by the heat when dough which has been raised by yeast is baked in bread-making?
6. Why is yeast used in making bread?

VII. BACTERIA AND THEIR WAYS

(Look over this article to see what material is required for the experiments)

You have learned that mushrooms and moulds feed upon the bodies of other plants, and often cause their death and hasten their decay; but it has been found by means of the microscope that the putrefaction and decay of organic matter is largely due to minute, one-celled plants called

bacteria (singular *bacterium*). These minute plants are so small that only a high-power microscope will magnify them sufficiently to render them visible to us; indeed most of them must be magnified about 1,000 times before we can see the little cells, each of which is a single bacterium. Although we cannot see the individual bacteria without a microscope, we can observe them in masses, called *colonies*, with the naked eye.

Press a little hay into the bottom of a bottle, fill the bottle up with water, set it aside in a warm place for a few days. A gelatinous scum will form on the surface of the water. This scum is a mass of bacteria. If you were to place a speck of this scum in a drop of water, under a powerful microscope, you might see great numbers of bacteria lying or swimming about in the drop.

Cut a damp cooked potato into slices about half an inch thick, and then cut the slices into cylinders of such diameter that they can be dropped into a small wide-mouthed bottle. Put one or two cylinders into each of five bottles, and plug the mouth of each bottle rather tightly with a stopper made of cotton wool. This will prevent the entrance of bacteria, while not excluding the air.

Procure an enamelled pail or a deep basin with a cover. Invert in the bottom of it a low dish with a flat bottom which has been perforated with small holes. Pour in some water, and set *four* of the



(a)

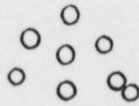

(b)



(c)

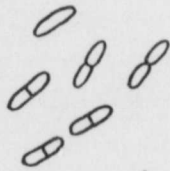

(d)



(e)



(f)

FORMS AND STATES OF BACTERIA

(All greatly magnified)

(a) ROD-SHAPED BACTERIA (BACILLI). (b) SPHERICAL BACTERIA (COCCI). (c) SPIRAL BACTERIA (SPIRILLA). (d) BACTERIA MULTIPLYING BY FISSION. (e) BACTERIA FORMING SPORES (INSIDE). (f) THE BACTERIA OF CONSUMPTION (BACILLUS TUBERCULOSIS).

bottle
the p
the v
stea
have
vesse
heat
used
steril

In
killed
four
thirty
of th
to sh
back
dark

Lo
cours
will
potat
will
these
signs
other
velop
surfa
due 1
Ho

bottles on the perforated bottom of the dish, cover the pail or basin, set it on a hot stove, and boil the water for thirty minutes. The heat of the steam should kill most of the bacteria that may have been on the potatoes or elsewhere in the vessel. The process of killing the bacteria by heat is called *sterilization*, and the apparatus we used in this instance may be called a steam *sterilizer*.

In order to find whether all the bacteria are killed, leave the bottles in a warm place for twenty-four hours, and steam three of them again for thirty minutes. Wait another day and steam two of them for the third time. Label all the bottles to show how often each was steamed. Put them back into the vessel and keep them in a warm, dark place near a stove or a radiator.

Look at the bottles from time to time, but of course do not remove the cotton stoppers. You will probably soon see moulds growing on the potato in one of the bottles. Quite likely there will be bacteria growing there as well, but these you cannot see. It is probable, too, that signs of decay will appear on one or two of the other pieces of potato on which no moulds develop. A slimy growth may appear on the surface, which may gradually spread. This is due to the growth of bacteria on the potato.

Hot steam will kill most bacteria in their

ordinary condition, in a short time, but it has been found that many bacteria form *spores* which will withstand the heat of boiling water for a long time. If bacterial decay takes place in any of the bottles which were steamed once, explain the effect by the presence of spores which were not killed by the heat.

Note whether either moulds or bacteria grow on the potatoes which were steamed two or three times, and account for the fact.

You may next inoculate a slice of sterilized potato in a sterilized bottle with bacteria from the hay infusion. Take a long needle or a hat-pin and sterilize it by passing it several times through the flame of a spirit lamp. *As soon as the needle is cool*, dip it into the film on the surface of the hay infusion. Hold the sterilized bottle containing the potato nearly horizontal. Remove the stopper, draw the point of the needle once across the surface of the potato, and replace the stopper at once. Expose another slice to the air, by removing the stopper from the bottle for five minutes. Observe these two cases carefully, and note and explain the results.

Sterilize some water by boiling it in an enamelled cup. As soon as the water is cool, with a sterilized needle take a small drop from the surface of the hay infusion and stir it in the water. Sterilize the needle again; dip it into the water and touch the

sterili
the n
ilized
in dir
will k
growt
bacter
small,
numb
active
Each
two t
favor
and i
terieur
the e

The
color.
differ
distin
their
specie
canno

Bes
bacter
and th
culosi
other
the b

sterilized potato at a few points with the point of the needle. Plug the bottle immediately with sterilized cotton wool and set it in a warm place, not in direct sunlight. Watch to see what the result will be. If you used water enough the bacterial growth at each spot probably came from a single bacterium. The infected spot, although quite small, will contain a whole colony of bacteria, numbering many thousands, for bacteria in the active state multiply with wonderful rapidity. Each bacterium being a single cell divides in two to form two bacteria. This division, under favorable conditions, takes place in half an hour, and if kept up for a day at this rate one bacterium would increase to many millions. Make the calculation.

The colonies of bacteria sometimes differ in color. This means probably that they belong to different species. Some species of bacteria may be distinguished by the color, shape and appearance of their colonies. The individual bacteria of different species differ in size and form, but of course this cannot be seen without a microscope.

Besides aiding in the decay of vegetable matter, bacteria often attack living animals and plants, and thus cause many diseases. Diphtheria, tuberculosis (consumption), typhoid fever, and many other diseases are due to the growth of bacteria in the body. Each disease is caused by a different

species of bacteria. The bacteria produce poisonous substances which spread through the body in the blood. Scientific men have been, and are still, trying to find means of killing these disease-producing bacteria or stopping their growth, without killing the patient who is suffering from their attack.

Bacteria are often called *germs* or *microbes*. Germ diseases can be transferred from one person to another. The disease germs may pass from a diseased person to another through the air or by contact.

Disease-producing bacteria are frequently found in water and in milk. In case of suspicion, it is wise to sterilize the water before drinking by boiling it. The milk should be heated to 155° Fahr. for twenty minutes and then cooled. This process, called *pasteurizing*, will kill the disease-producing bacteria in the milk.

If we keep our bodies clean and pure and our health vigorous, we are much less liable to be attacked by the bacteria of disease. Cleanly habits, enough but not too much good food, daily exercise in the open air, and well-lighted and ventilated rooms in which to work and sleep, all contribute to protect us from the attacks of these dangerous germs, and to fit the body to resist them if they do find a lodgment.

But we must not forget that many bacteria are

useful
useful
anima
bacter
the hi
tions,
wine
ferme
verted
cheese
in ma
econo

1. M
the fiel
2. A
has un
till the
Test w
out wh

useful or harmless. The bacteria of decay are useful in removing the dead bodies of plants and animals. The soil contains great numbers of bacteria which are of service in preparing food for the higher plants. Some bacteria cause fermentations, such as acetic fermentation, by which beer, wine or cider is converted into vinegar, and lactic fermentation, by which the sugar of milk is converted into lactic acid. Bacteria help to ripen cheese and impart to it an agreeable flavor, and in many other ways they play a useful part in the economy of nature.

EXERCISES

1. Make a collection of specimens from the home and from the fields and woods illustrating the work of bacteria.
2. After a bottle containing a solution of molasses in water has undergone alcoholic fermentation, set it aside uncorked till the solution smells like vinegar (acetic acid solution). Test with litmus paper. Account for the change, and point out what became of the alcohol.

WINTER LESSONS

VIII. THE DOMESTIC ANIMALS OF THE HOME AND FARM

ALL our domesticated animals once lived the independent life of wild creatures, maintaining the struggle for existence alone by their own powers of self-preservation.

The dog and the cat were domesticated thousands of years ago, probably before there was any written history, and while man was still a savage. The dog is believed to have been at first a wolf or a jackal, preying perhaps in packs upon the less aggressive wild animals of the forest and the open plain. He has been greatly changed by his long association with man, and has developed traits which seem to be quite human, such as his evident pleasure at being praised. Indeed, in his warm response to the affection of his master, and his faithfulness to him even in adversity, he displays qualities only too rare among men. In earlier ages the dog was no doubt of great service to man in safeguarding him against his enemies, and assisting him in the chase.

The cat retains more of the original savage characteristics of her wild ancestors than does the

dog.
ridi
and

In
gene
com
destr
prob
tious
to he

Ou
the v
of th
ago
gener
and
and
The
man-
thres

Ma
differ
been
have

Th
active
cliff
are s
hemis

dog. The cat has done considerable service in ridding man of meaner enemies, such as mice and rats.

In these days, however, dogs and cats are in general not so necessary to us. Indeed, in many communities cats are far too numerous. They destroy large numbers of song birds, and it is probable that they often carry the germs of infectious diseases in their frequent visits from house to house.

Our domestic cows and oxen are descended from the wild cattle which once roamed over the plains of the Old World, as did the buffaloes not long ago over our western plains. During many generations they have contributed largely, in food and clothing, to supply the needs of the tribes and nations who domesticated or adopted them. The ox has done an immense amount of work for man—hauling the cart, dragging the plough, and threshing out the grain.

Many breeds of cattle have been developed in different parts of the world. Some breeds have been specially adapted for producing milk; others have been bred chiefly for beef.

The sheep was originally a mountain animal, active and sure-footed, able to leap from cliff to cliff and scale the mountain peaks. Wild sheep are still found in mountainous regions in both hemispheres. Sheep formed a large part of the

wealth of the pastoral tribes of Asia ages ago. In cold-temperate countries their wool is indispensable for clothing, and their flesh forms a large part of our animal food.

The horse, the noblest of our domestic animals, was tamed in very early times by savage peoples. He has long been employed, both in peace and war, as a source of speed and of power.

The ancestors of the domesticated horse wandered over the plains of the Eastern Continent, but it is quite doubtful whether the original wild horse still exists. It is generally believed that the modern wild horses of Asia are descended from domestic animals which have escaped from the control of man.

There were no horses either wild or tame in America at the time of its discovery by Columbus. Geologists tell us, however, that there were horses in America long ages ago, but that they all died out. The American horses of the present day are descended from those brought across the Atlantic since the year 1492.

Breeding for speed has given us the race-horse, while breeding for power has developed the draught-horse at the other extreme. Horses are now very commonly used for general farm work, taking the place, as a beast of burden, formerly held by the ox.

The useful but much despised pig was once a



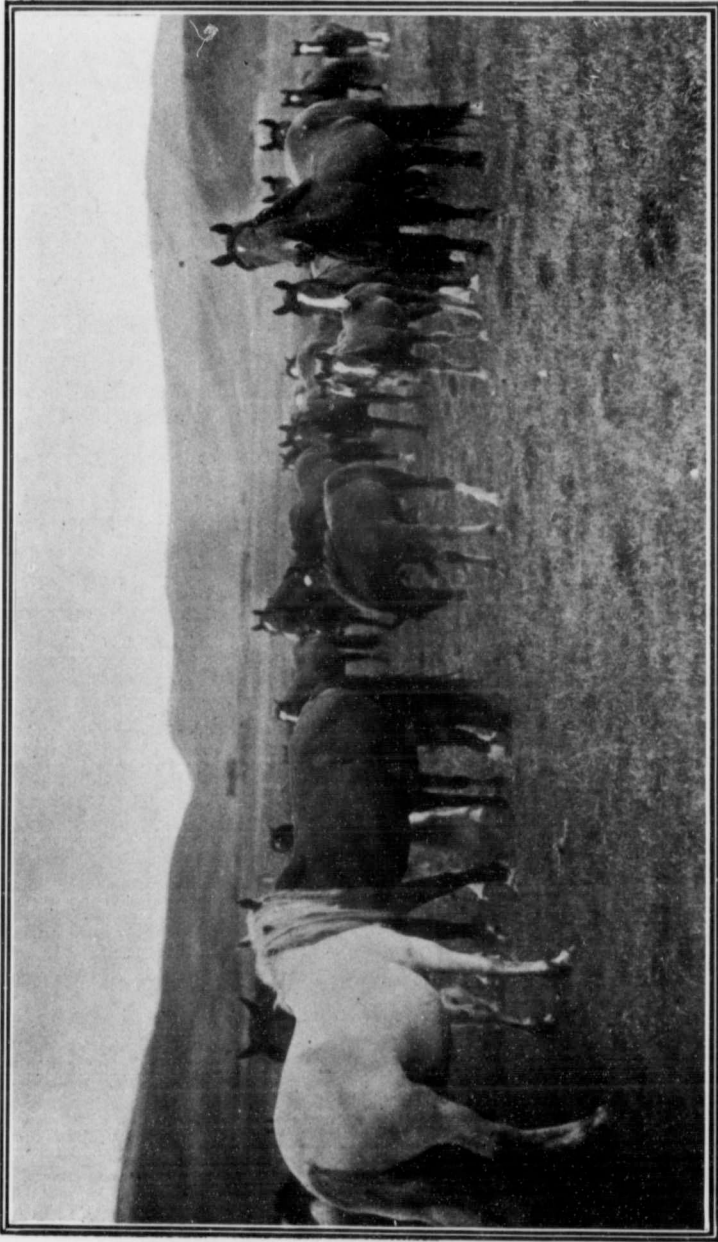

HAPPY ON THE RANGE.

Reproduced by permission of C. F. B. Colonization Department.

feroc
jung
all th
fat, c
It h
and
Th
deriv
dom
whic
parts
desce
goose
wild
is a
the s
soutl
main
turke
soon
Th
the
have
their
depe
and
provi
part
finan

ferocious beast—a wild boar—in the forests and jungles of the Old World. As a domestic animal, all that is required of the pig is to grow fast and fat, on such food as its owner permits it to have. It has accordingly degenerated in self-reliance and in intelligence.

The species from which our domestic fowls are derived can still be found in the wild state. The domestic hen came from a species of wild fowl which still inhabits Northern India and other parts of Eastern Asia. Our tame ducks are descended from the wild duck, and the domestic goose from one or more species of the migratory wild geese of the Eastern Continent. The turkey is a native of America and is still found wild in the southern part of the United States and farther south. The domestic turkey is probably derived mainly from the Mexican variety of the wild turkey. This fowl was introduced into Europe soon after the discovery of Mexico.

The Care of Domestic Animals. Since man deprived the domestic animals of their wild freedom, they have largely lost their powers of self-defence and their habits of self-reliance. They have become dependent on man for protection, food and shelter, and frequently suffer from their owner's neglect to provide for them. This is not only cruel on the part of their owner, but is always a cause of financial loss to him. Animals which are well

fed and cared for will always give their master a more satisfactory return.

All the domestic animals—like human beings—require nourishing food containing a sufficient amount of carbohydrates and proteids (not forgetting enough common salt to supply the natural craving of the animals), pure air to breathe, pure water to drink, clean bodies, exercise, and a temperature at which they can be comfortable. Our northern winters are so cold that they all need more or less shelter from its severities. The buildings provided for their shelter in winter should be clean, well-ventilated, dry, free from draughts, and well lighted from windows.

It is very important that the animals should not be kept too warm. Stables for cattle and horses should be kept in winter at a temperature ranging from about 45° to 55° Fahr.

Cattle as well as horses should be groomed regularly with brush or comb, and their stables should be provided with straw or other litter for bedding. Sheep demand greater freedom than cattle, and their warmer coats protect them better from severe cold. They may be allowed to run freely in and out of their sheds, except at night.

Poultry-houses should be of light construction. The same conditions as to draughts, ventilation, light, cleanliness and dryness apply to them as to the stables for cattle. In cold weather poultry,

like
whic
free
be al
He
oats-
green
ing n
veget
meal,
little
dry.
and n
additi
be fe
ounce
requir
grave
The
in the
carryi
mind
differ
Pou
manag
can or
of go
subjec
experi

like other animals, require a warmer place in which to sleep than they need for exercise and free movement, but the temperature should never be above the point of comfort.

Hens are fed mostly on grain—wheat, corn, and oats—but also require some softer food, and also green food. In *fattening* fowls, food for the morning meal may be prepared by boiling together clean vegetables of nearly any kind, and stirring in corn meal, bran, ground oats and ground meat, with a little salt—till the whole mass is quite firm and dry. Fresh clover makes good green food. Bones and meat shaved in a bone-cutter make a valuable addition to the food of laying hens, but must not be fed too often or in too large quantity. An ounce to each hen is enough at a time. Poultry require pure fresh water (*warm* in winter) and gravel or sharp grit, as regularly as they need food.

The same principles as to care and food apply in the management of all kinds of fowls; but in carrying out these principles we must keep in mind the natural characteristics and habits of the different species.

Poultry-keeping is very profitable if well managed. The necessary knowledge and skill can only be gained by experience, but the reading of good books and newspaper articles on the subject will shorten the time needed in acquiring experience, and lessen the loss due to mistakes.

We must not forget to mention our domesticated insect, the honey bee. These busy little creatures do well in favorable localities, when under the care of someone who will take the trouble to study their habits and their needs.

IX. THE COMPOSITION AND CARE OF MILK

Material.—A pint or two of milk, a sample of milk sugar, a little extract of rennet, hydrochloric acid, vinegar, litmus paper, a muslin strainer, tumblers, bottles, spoons, enamelled cups, a spirit lamp.

You do not remember it, but you must admit the fact that during the earliest weeks or months of your life your food consisted entirely, or almost entirely, of milk. Indeed the young of all mammals—those animals next below human beings in the scale of existence—are fed on milk alone for some time after birth.

It is evident, then, that milk must be a nourishing food, and that it must contain all the substances necessary for building up bone, muscle, nerves, brain, and the other tissues of the animal body. Let us try to find by experiment some of the substances of which milk is made up.

Set some fresh milk aside in a narrow bottle for a few hours until it separates into two layers. The layer which forms at the top is called *cream*.

Comp
the c
off t
remo
whic
crean
on p

We
has r
crean
but e
not k
milk

Yo
you c
water
will s
still.
to th
like t
than
ever,
very
conta
the m

Wh
const
stick
butter

Compare, by actual measurements, the depth of the cream with that of the milk below it. Skim off the cream. The milk remaining after the removal of the cream is called *skim milk*. Try which feels more oily—the skim milk or the cream—and which will give the better oil spot on paper.

We see that the greater part of the oil in milk has risen toward the surface and is now in the cream. The oil in the milk is not dissolved there, but exists as very small solid globules which cannot be seen without a microscope. The oil of milk is called *butter fat*.

You know that oils are lighter than water, and you can easily show by shaking any oil up with water that it will not dissolve in the water, but will soon rise to the top when the water becomes still. This explains why the globules of fat rise to the top in the milk. They are not dissolved like the other solids in the milk, and being lighter than water they tend to rise. The cream, however, is not pure fat. It is only milk which is very much richer in fat than the skim milk, and contains in less amount the other constituents of the milk.

When we agitate the cream in a churn the constant motion causes the globules of fat to stick together and form grains of butter. The butter is taken out of the churn when the grains

get to be about as large as wheat grains. The part of the cream which remains after the butter is taken out is called the buttermilk. One hundred pounds of good average milk should yield about 20 lbs. of cream, and 20 lbs. of cream should yield about $4\frac{1}{2}$ lbs. of butter.

The butter itself is not pure fat, but contains in small proportion all the other substances found in milk. The buttermilk should contain very little fat, but all the other constituents of the original milk are represented in it. Buttermilk is a nourishing and very digestible food.

Heat a little milk in a cup or a test tube till a skin forms over the surface. You can recall the fact that the albumen dissolved in potato juice was solidified by heating the juice. Similarly the albumen in milk is solidified (coagulated) by heat. The tough skin formed on the milk by heating it is not pure albumen, however, for some fat and other solids of the milk are entangled with it.

Warm a tumbler of fresh milk till its temperature is about that of the human body, and add enough extract of rennet to curdle it. The substance which was solidified (coagulated) by the rennet is called *casein*. Casein, like albumen, is a proteid. It is the principal proteid in milk. The white curd or clot, however, is not composed of casein alone, for when the casein coagulated the fat and albumen were caught or entangled

in th
subst

Squ
throu
liquid
prope

Tas
slowly
appea
vapor
identi
whey
whey
chiefly
weigh

But
call t
most
sugar
Find
than c

Set
it curd
The ac
acid.
the ac
hydroc
will co
Hea

in the clot, as well as a portion of the other substances in milk.

Squeeze the liquid out of the clotted milk through a thin cloth into a bowl or cup. This liquid is called *whey*. The curd in the cloth, if properly pressed and cured, would be *cheese*.

Taste the whey and evaporate some of it very slowly to dryness. The whey has a very watery appearance. Catch in a cold tumbler some of the vapor which escapes during the evaporation, and identify it by touch and taste. You will find that whey is mostly water, and since the water in the whey was first in the milk, milk must consist chiefly of water. Indeed seven-eighths of milk by weight is water.

But what makes new milk sweet? You may call the sweet substance *milk-sugar*, and since most of the sugar remains in the whey, milk-sugar is obtained by the evaporation of whey. Find whether milk-sugar is more or less sweet than ordinary sugar.

Set some fresh milk aside in a warm place till it curdles; then taste it, and test it with litmus. The acid which formed in the milk is called *lactic acid*. It is formed from the milk-sugar through the action of a kind of bacteria. Try whether hydrochloric acid and vinegar (dilute acetic acid) will coagulate the casein as lactic acid does.

Heat a piece of curd in a metal dish or a spoon

until all the material which will evaporate or burn has disappeared. The remainder is mostly the ash or mineral matter of the milk. You may not be able to burn out all the charcoal, and therefore the ash will look black. The ash of milk is made up of various salts, one of which is phosphate of lime (calcium phosphate), which is the principal constituent of the bones of animals.

A great many kinds of bacteria are liable to get into milk and multiply rapidly there. Some of these produce changes in the milk which spoil it for drinking and for the making of butter and cheese. Some disease-producing bacteria multiply rapidly in milk if they gain admission, and render it very dangerous to drink.

It is possible, however, to secure a regular supply of good clean milk. The cows must be free from disease. They must be kept in a healthy condition by good food and intelligent care. The utmost cleanliness is indispensable. Their stables should be well ventilated and well lighted. They should have enough pure water to drink. They should be brushed regularly, but not at milking-time, as the dust contains many forms of bacteria. Less dust, and therefore fewer bacteria, will fall into the milk if the udder and adjoining parts are wiped with a damp cloth just before the cow is milked.

The room and all the vessels in which the milk

is kept
there
All the
milk
water
with
thorou
out th
makin

Even
ucts s
by wh
condit
in boo

Material
lime-wa
tubes, w
fine iron

Each
fragment
cannot b
marble is

Try
glass
a knife
powde

is kept must be scrupulously clean. Wherever there is dust, dirt or decay, there are bacteria. All the vessels used in holding or transferring the milk should be thoroughly washed with warm water and soap after being used and then scalded with hot water before they are dried. The same thorough cleanliness must be observed throughout the processes of cheese-making and butter-making.

Everyone who sells or uses milk and its products should keep fully informed on the methods by which they may reach the table in the best condition. The details of these methods are given in books and bulletins on dairying.

X. A LESSON ON LIMESTONE

Material.—Spirit lamps, dilute hydrochloric (muriatic) acid, lime-water, a little unslacked lime, red litmus paper, test tubes, wide-mouthed bottles, knives or pointed pieces of steel, fine iron wire, wooden test sticks, small bowls, a cheap balance.

Each member of the class should be supplied with a few small fragments of limestone, and one larger piece. If ordinary limestone cannot be obtained in the locality, waste marble will answer, since marble is a variety of limestone.

Try whether limestone is hard enough to scratch glass or soft enough to be easily scratched with a knife. Notice its streak, that is, the color of its powder. This is found by simply scratching it

with something which has a hard point. A little powder is left lying in the groove thus made.

Put a drop of hydrochloric acid on the stone. If it is really limestone, bubbles of gas will arise from it wherever the acid touches it. These properties will enable you to distinguish limestone of any variety from other minerals.

Procure a piece of fine iron or steel wire (florist's wire), and bend one end of it into the form of a catch to hold a *very small thin* fragment of limestone. Hold this bit of limestone, by means of the wire, in the hottest part of the flame of a spirit lamp, and keep it glowing there for about five minutes, or till the thinnest part of it looks white and lustreless when cool. Observe that neither the limestone, nor the white substance produced from it by the heat, will burn. When it becomes cool, drop the fragment from the wire upon a piece of red litmus paper, and wet it and the paper with a drop of water. You will soon notice a decided change of color in the paper.

Try whether a piece of limestone which has not been heated will act on the litmus in this manner; also try a bit of lime.

You will find that the white powdery substance produced by heating the limestone resembles lime in its physical properties, and acts on damp red litmus paper as lime does, from which we may conclude with some certainty that the dull white

substance
stone

Put
stone
little w
any vis
and ad
an acti
so that
air, int

Since
the gas
when s
in app
is set
hydroc
of the
dioxide

Since
and by
we set
that lin
and ca

We l
not tho
position
of lime
solve it
fine iron

substance is lime. So by heating a piece of limestone we have obtained a little *lime*.

Put a teaspoonful of small fragments of limestone into a test tube or a small bottle. Add a little water to the limestone and observe whether any visible effect is produced. Pour the water off, and add enough dilute hydrochloric acid to cause an active bubbling. Hold the test tube or bottle so that the gas as it issues may fall, if heavier than air, into a small wide-mouthed bottle.

Since a burning stick is at once extinguished by the gas which sank into the bottle, and lime-water, when shaken through it, is turned white or milky in appearance, it is evident that the gas which is set free by the acid is *carbon dioxide*. Since hydrochloric acid, as its name implies, is made up of the elements hydrogen and chlorine, this carbon dioxide must have come out of the limestone.

Since by heating limestone we get lime out of it, and by treating limestone with hydrochloric acid we set carbon dioxide free from it, we conclude that limestone contains the elements of both lime and carbon dioxide.

We know the elements of carbon dioxide, but not those of lime; so we will try to find the composition of lime. Break into powder a small piece of lime, and add enough hydrochloric acid to dissolve it entirely or partly. Make, at the end of a fine iron wire, a close coil large enough to contain

a drop of the solution, and hold the drop in the flame of the spirit lamp. You should obtain a red flame color.

Note that a drop of the acid in which no lime has been dissolved will not color the flame red; therefore the red color must be due to something in the lime. The substance in the lime which produces the red flame color is called *calcium*. It has been found to be a metal somewhat resembling silver.

But lime is evidently not composed entirely of calcium, for lime is a dull, crumbly substance without a metallic lustre, bearing no resemblance to a metal.

We have seen that lime will not burn any more than carbon dioxide will, and the reason has been found by chemists to be the same. Carbon dioxide will not burn, that is, will not unite with the oxygen of the air, because the carbon in it is already chemically united with oxygen, and so lime will not burn because the calcium in it is already united with oxygen. As lime is a compound of calcium and oxygen, its chemical name is *calcium oxide*.

Limestone, then, is made up of calcium oxide and carbon dioxide, that is, of the elements calcium, carbon and oxygen. Hence the chemical name of limestone is *calcium carbonate*. The first word of this name indicates the metal, the first

part
endin
Lime
becau
lime.
obtai
carbo
lime-
We
the be
lime
off bu
replac
come
free c
test st
All
dry.
weigh
did.
Sinc
the w
chemic
itself,
thus i
then, i
united.
You c
elemen

part of the second word the carbon, and the ending, *ate*, the third element, oxygen.

Limestone is frequently called carbonate of lime, because it is a carbonate which, when heated, yields lime. The lime of commerce, put up in casks, is obtained by heating some form of limestone—carbonate of lime—in a large furnace called a lime-kiln.

Weigh, or balance on a scale, a lump of lime in the bottom of a bowl. Soak the lump of unslacked lime (quicklime) in water until it ceases to give off bubbles of air from its pores, then promptly replace it in the bowl. The lime will soon become quite hot, but neither free hydrogen nor free oxygen is given off, as you can prove with a test stick.

Allow the mass to become cool and perfectly dry. You will find that this dry slacked lime weighs more than the lump of unslacked lime did.

Since neither the hydrogen nor the oxygen of the water was given off, the lime must have chemically united with some or all of the water itself, that is, with both elements of the water—thus increasing in weight. Water-slacked lime, then, is composed of lime and water chemically united. It is therefore called *calcium hydrate*. You can see that this name indicates the three elements in the water-slacked lime.

Shake a spoonful or two of the dry calcium hydrate through a bottle of water, and let the mixture stand till the water becomes clear. Taste the clear liquid and test it with red litmus paper.

The taste and the change in the color of the litmus indicate that the water has a *base* dissolved in it. This base can be none other than the calcium hydrate, part of which must have dissolved in the water while the rest settled, as you see, to the bottom, because there was not water enough to dissolve it all. The clear solution of calcium hydrate (water-slacked lime) in water is called *lime-water*.

Dissolve a little limestone, lime and water-slacked lime, separately, in hydrochloric acid, and take a flame test in each case. You will always obtain the same flame color. We have said that the metal to which this color is due is called calcium, but you have not seen, and cannot see, the calcium in these three substances, because in each it is chemically united with one or two other elements.

EXERCISES

1. What invisible substance passes off into the air when you heat limestone intensely? Give a reason for your answer.
2. Why will limestone not burn?
3. Which weighs more, the limestone or the lime which may be obtained from it? Why?

X
J.
pail
piec
salty
I
into
the
the
wat
off
unt
clea
L
the
clea
till
bott
unti
bott
U
sepa
the
larg
and
coar
look
yield

XI. THE SOLID CONSTITUENTS OF THE SOIL

Material.—Fine garden soil, black peaty soil or leaf-mould, a pail or basin, wide-mouthed bottles, spirit lamps, lime-water, pieces of glass, lamp chimneys, cotton wool. Specimens of saltpetre (nitrate of potash) and of nitrate of soda.

Put about a tablespoonful of fine garden soil into a wide-mouthed bottle. Add water and mix the soil and water together by stirring. Pour off the muddy water into a large vessel, mix more water with the residue left in the bottle, and pour off the muddy water again. Repeat this process until the water which you pour off is nearly clear.

Let the large vessel stand for several days until the muddy water becomes clear. Pour off the clear water, and set the vessel in a warm place till the sediment becomes dry. Also set aside the bottle in which the water and the soil were mixed, until the part of the soil which remained in the bottle is dry.

Upon comparing the two parts, into which you separated the soil by means of the water—that is, the portion in the bottle and the portion in the large vessel—you will find one much coarser and harsher to the touch than the other. The coarser gritty material resembles sand; the finer looks like impure clay. If your sample of soil yields about equal weights of sand and clay, you

may call the soil a *loam*. If the sand is much heavier than the clay, the soil was a *sandy loam*; but if the clay was considerably heavier than the sand, you had a sample of a *clay loam*.

Pure clay, however, is white, as you may see it in clay pipes and other articles made of white clay. Probably the clay you obtained from the garden soil looks quite dark. If you place a small piece of this dark clay or of leaf-mould in an iron spoon or in a small coil of wire, and heat it in the flame of a spirit lamp, you will find that it will glow like a piece of charcoal would do, and that the black substance slowly burns away, leaving the residue grayish in color.

If you could collect the gas produced by the burning of this dark substance, you would find that carbon dioxide is produced. Both the dark color and the manner in which the substance burns indicates that it contains carbon.

This dark substance which is so abundant in some soils as to make them nearly black is called *humus*. You will observe that it is most evident in soils where large quantities of vegetable matter have been slowly decaying in damp places, as in woods and boggy lands. Humus is largely supplied to gardens and cultivated fields in the form of barnyard manure. This manure is simply vegetable matter—hay, grain, etc.—which the animals did not assimilate.

It must be remembered, however, that humus does not consist entirely of the carbon of the decaying plants. It contains in some proportion the other elements of the carbohydrates and the proteids of which plants are mainly composed. You have not forgotten that carbohydrates consist of carbon, hydrogen and oxygen, and that proteids contain, besides these three elements, two others, nitrogen and sulphur. Some proteids also contain phosphorus. Compounds of phosphorus, called phosphates, are, therefore, necessary constituents of every fertile soil, as also are those compounds of sulphur called sulphates.

The humus in the soil is one source whence the growing plants obtain the nitrogen which they need for making proteids. The higher plants, we are told, cannot use the nitrogen of the humus, nor the free nitrogen of the air. The nitrifying bacteria found in all good soils render the nitrogen of the humus available to the higher plants by using it to form nitrates. The nitrates being soluble in water are absorbed by the root-hairs of the higher plants, and the nitrogen of these nitrates is used by the plant in the manufacture of proteids, such as albumen, fibrin and legumin.

Examine the dry sand you obtained from the soil. You will find that it is a mixture of different minerals. The commonest mineral in sand is a

very hard one, called quartz. It is usually white and opaque—then called milky quartz—but often it is colorless and transparent, resembling glass but harder. Indeed it will not only scratch window glass, but it is harder than ordinary steel; so your knife will not cut or scratch it.

Try whether you can find any of this hard mineral in the sand. Quite likely you will find other minerals as well. The yellow and red colors you notice in soils are usually due to the presence of iron rust, which is an oxide of iron. A very small amount of this oxide of iron in a mineral or in a soil will impart to it a reddish or yellowish color.

Next examine the clay. It is not pure clay at all, else it would be white. It was pointed out before that it probably contains more or less humus, but humus is vegetable matter. If you could test the particles of clay separately you would probably find more minerals in the clay than in the sand.

Drop a little hydrochloric acid on the dry clay and on the sand. If bubbles of gas are set free in large amount you should put some of the soil into a test tube or a small bottle, treat it with the acid, and empty the gas into a bottle containing a little lime-water. Upon shaking the lime-water through the gas you will at once know what gas it is. This is the gas which the acid sets

fre
val
cor
is
1
mi
a g
col
the
we

1
clay
ther
2
of a
3
reac
4
of p
the
Exp
5
form

free from limestone (carbonate of lime)—a very valuable constituent of the soil. A soil which contains a large proportion of carbonate of lime is called a *calcareous* soil.

We now see that the soil is a mixture of different minerals in a fine state of division, together with a greater or less amount of partially decayed dark-colored vegetable matter called humus. Of course the soil contains many minerals other than those we have mentioned.

EXERCISES

1. Devise experiments to show the difference between clayey and sandy soils in allowing water to sink through them and to rise through them.
2. Try whether humus makes any difference in the power of a soil to absorb or hold water.
3. Find whether nitrate of potash and nitrate of soda are readily soluble in water.
4. Mix a little dry powdered leaf-mould with a teaspoonful of powdered lime. Heat the mixture in a test tube. Smell the escaping gas and note its effect on damp litmus paper. Explain.
5. Try to find how the soils in your neighborhood were formed.

XII. AIR AND WATER IN THE SOIL

Material.—Some garden soil, flower-pots, pickle bottles or other wide-mouthed bottles, an enamelled cup, a small basin, beans, peas or other large seeds, enamelled cups or test tubes, square pieces of glass.

Fill two-thirds of a quart bottle with ordinary soil, and shake the soil down well. Quickly pour enough water upon the soil to cover the surface of it to the depth of an inch or two. How do you account for the large number of bubbles which rise through the water. How could so much air find room in the soil? Add water to the soil till the air ceases to rise. What now fills the space which had been occupied by the air?

Fill two flower-pots with garden soil of the same quality, and germinate a few seeds in each pot. Set the pots in a warm place, and keep the soil moderately damp. When the plants are well started, saturate the soil in one of the pots with water to exclude the air, and keep it saturated by setting the pot in a basin of water. Keep the soil in the other pot slightly moist, but not wet enough to exclude the air. After a time, you should see a decided difference between the plants in the two pots. Describe and explain the difference.

You should recollect here that plants breathe, and therefore require oxygen from the air. As plants are composed of cells, we must suppose

that
the
requ
spac
wat
that
lear
in
can
air
land
T
of d
to
time
wate
occu
It
with
very
you
form
laid
Y
deep
wate
capil
in a
even

that not only the cells in the leaves but those in the roots, as well as in the other parts of the plant, require oxygen. We can see, then, that when the spaces between the particles of soil are filled with water the roots may suffer for lack of the oxygen that they might have got from the air. We will learn that the air in the soil is useful to the plants in other ways. Plants which live under water can obtain oxygen enough, as fishes do, from the air dissolved in the water, but this is not true of land plants.

The last experiment emphasizes the importance of drainage in the case of all soils which are liable to remain soaked with water for a considerable time after rains. The drains carry off the surplus water, and allow the air to penetrate the soil and occupy the spaces between the soil particles.

It seems strange that plants can live so long without rain, in dry soil. If, however, you put very dry soil into an enamelled cup and heat it you will find that water will rise out of it in the form of steam, and condense on a piece of glass laid upon the mouth of the cup.

You have noticed too that when people dig deeply into the earth they sooner or later reach water. Much of the soil water rises gradually, by capillary attraction, towards the surface—as oil rises in a lamp-wick—and supplies the roots of plants, even in very dry seasons, with water from below.

Were it not for this underground supply all vegetation would cease in long periods of drought, for plants require large quantities of water. They need water for making carbohydrates—such as starch, sugar and wood—all of which consist of carbon and water. They need it for making proteids, which contain the elements of water, and for the sap in which the food of the plant must be dissolved. Indeed the plant must take in, dissolved in water, all the food material absorbed by the root-hairs. We know that the plant requires much more water than it retains within its body, for we have seen how rapidly water is given off in transpiration by the leaves of plants.

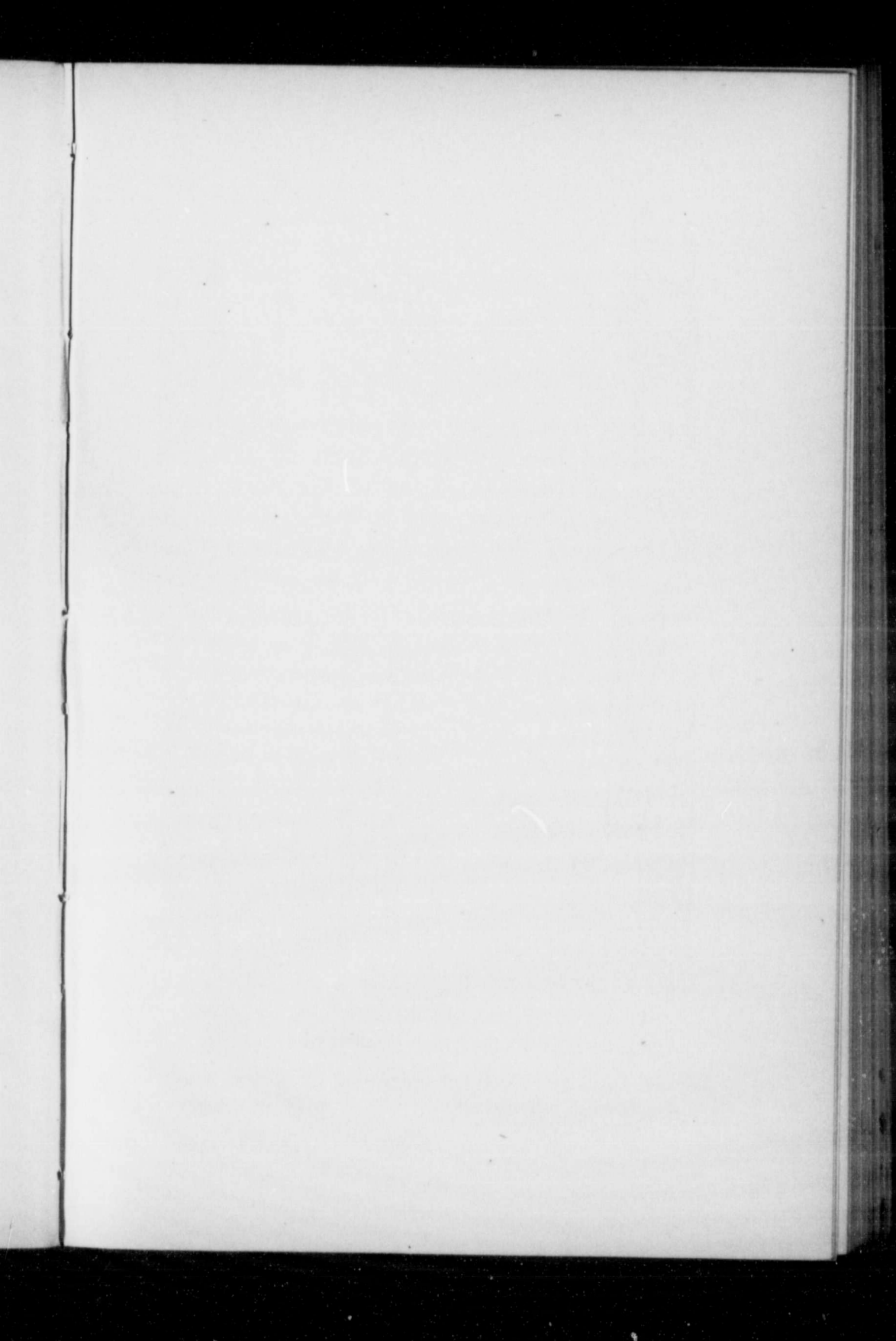



(c)



(a)



(b)



(d)



(e)



(f)

BUDDING AND GRAFTING

(a) BUD READY FOR INSERTION.
 (c) BUD INSERTED AND WRAPPED.

(b) SLIT IN BARK OF STOCK.
 (d, e, f) STEPS IN GRAFTING.

XIII.

Fr
 mean
 little
 suita
 etc.,
 prod

Ma
 We
 bran
 order
 ate r
 its o

It
 buds
 that
 it is
 closel
 was

Ev
 by it
 root
 tion
 by cu

SPRING LESSONS

XIII. THE PROPAGATION OF PLANTS FROM BUDS

FLOWERING plants are usually multiplied by means of *seeds*. Every perfect seed contains a little plant which is capable of developing under suitable conditions of heat, moisture, light, soil, etc., into a mature plant similar to the one which produced the seed.

Many plants can be easily propagated by *buds*. We have seen that a bud will develop into a branch or *shoot*. All that a branch needs, in order to become an independent plant, is a separate root. It already has a stem and leaves of its own.

It is often advantageous to grow plants from buds rather than from seeds. One advantage is that it does not take so long, and another is that it is often more likely that we will get a plant closely similar to the one from which the bud was taken.

Every bud on a tree might develop into a tree by itself, if we could but secure for each bud a root of its own. Four methods of bud propagation are in use: grafting, budding, layering, and by cuttings.

Cuttings. In making cuttings from plants with soft and juicy stems, such as the geranium, coleus and verbena, short pieces with two or more leaves are cut from vigorous shoots, the cut being made close below a node (the point at which a leaf grows out), and just above which a bud may form.

The cuttings are prepared by removing the lower leaves, and, if necessary, clipping the upper ones to prevent too great loss of water by evaporation. You remember that plants give off water mostly by the leaves. The smaller the leaf surface the less will be the loss by evaporation.

To keep the cuttings fresh, they are thrown as fast as they are trimmed into cold water. They are at first set out in moist sand in a shallow box. About half the length of the cutting should be covered, and the sand should be firmly pressed about it.

When the new roots are well started, the cuttings should be removed to little pots containing a mixture of sand and fine soil. When this pot is well filled with roots, the plants are ready to be transferred to larger pots. This should be done without greatly disturbing the roots.

The cuttings of some plants strike root well if set in a bottle containing water, so that the lower part of the cutting reaches a short distance below the surface of the water.

Cuttings from plants with hard woody stems, such as the currant, gooseberry and other shrubs, are made during the dormant season, after the leaves have fallen. They may be kept for a long time in a cool place in moist sand or sawdust. They should be "rooted" in moist sand, and when the weather becomes warm they may be at once set *obliquely* in good soil out of doors. Plants such as the blackberry, on whose roots buds will form, may be propagated from *root* cuttings.

Layering. Cuttings are separated from the parent plant before they form roots for themselves. In *layering*, the portion of the old plant which is to be used to form a new one is rooted before it is separated from the parent plant. This is often done by bending down the lower branches into slight depressions in the soil, pinning them there with a forked stick, and keeping this part covered with moist earth. After the root is well developed, the shoot is cut off below the root and set out in its permanent place.

If the shoot is too far from the ground to be rooted by the preceding method, roots may be started on the shoot before it is separated from the parent plant by encasing its stem—just above the point where it is to be cut off—with moss or soil kept constantly moist. The moss, two or three inches in thickness, must be wrapped tightly about the stem. If earth is used it may

be enclosed in a cylinder or box held in place by wire or twine.

A cut should be made partly around the branch to hinder the return flow of sap from the shoot which is to be removed. The moss and soil must be kept moist by frequent watering.

It is evident that layering must be carried out in spring or summer.

Budding. In both cuttings and layering, the shoots used for propagation form roots of their own, in the first after, in the latter before, separation from the parent plants. In *budding*, a single bud is taken from the plant to be propagated, and inserted in the bark of another related plant, which is to provide a support and a root for the new shoot which will arise from the inserted bud. If budding is to be done in spring, vigorous twigs are cut in the dormant season from a tree of the desired variety. These twigs are kept moist by packing them in boxes of moist sand or sawdust until the weather has become warm enough for active growth.

The best *stocks* are one year old from the seed. The stock is prepared for the bud by making a cross-shaped cut through the bark on the north or shady side of the stem close to the ground.

A bud for insertion in this stock is cut out from a twig as follows: Make a shallow cut through the wood and extending upward under the bud,

beginning about one-quarter of an inch ($\frac{1}{4}$ in.) below the bud. Then make another cut crosswise through the bark about one-quarter of an inch above the bud. Lift the edge of the bark here, and carefully peel it back and remove the bud, leaving the wood which you loosened by the first cut attached to the twig. If the inside of the bud, as removed, is hollow, you have spoiled it, for it needs the woody bundles here to unite with the cambium or growing layer of the stock. To insert the bud, raise the edges of the bark at the cross-shaped incision in the stock, and push the bud down under the bark until it fits neatly. Bring the parts into close contact by tying with soft twine or moist raffia.

When it becomes clear that the bud has united with the stock, the binding should be cut, and then, or early in the next season, the stem of the stock should be cut off a short distance above the bud. It is well to cover the cuts with wax.

Budding is sometimes done early in the fall. In this case the leaf blades below the buds should be cut off before the bud is inserted in the stock.

The bud will develop into a stem bearing branches, flowers and fruit. Although this new stem derives its water and soil food from a stock of a different variety, yet the fruit will be of that variety from which the *bud* came.

Grafting. In grafting, a *portion of a branch* (called the scion) from one tree is made to grow on the *root or stem of another tree* (called the stock). The stock is usually grown from the seed and should be of a hardy sort, while the scion is taken from a tree of a choice variety.

The scion will develop into a large stem with branches. It uses the root of the stock as though it were its own, and derives its water and food materials from the soil *through the stock*. Its growth, however, is due to the multiplication of its own cells by division, and the new cells have the same powers and properties as the cells of the tree from which the scion was taken. Consequently, the scion produces fruit of the same choice variety as its parent tree.

In *root-grafting*, the scions may be cut in mid-winter from the last season's growth of the branches, and stored in cool moist sand till the end of winter. They are then grafted on to the root, or short pieces of the root, of a young stock. In the case of the apple the stock should be about two years old.

There are different ways of setting the scion upon the root of the stock. In the *tongue-graft* the top of the root and the lower end of the scion are cut off evenly at the same slant, and a thin wedge or tongue is cut out of each near the middle of the slanting surface. The scion is then fitted

closely on the stock, so that the inner bark of each exactly meets that of the other in at least one place. The joints should be wrapped tightly with strips of grafting cloth about half inch wide. The grafting cloth is made by covering strips of cheese cloth or muslin with a mixture of four parts of resin and one part of beef tallow melted together. Exposed cut surfaces of the scion should be protected by covering them with grafting wax made by melting together four parts of resin, two parts of beeswax and one part of tallow.

Scions may be grafted on to the stem of the stock in a similar way. When the diameter of the stem or branch of the stock is greater than that of the scion, it is usual to make a *cleft-graft*. This is done by splitting the cut end of the stock and inserting two scions. The scions are cut so as to form a slender wedge at the base. Care must be taken to bring the *cambium layer* (between the bark and the wood) of each scion into close contact with that of the stock in at least one point. All cut surfaces should be carefully protected by grafting wax.

Old fruit trees may be used to produce new and choice varieties of fruit by grafting (*top-grafting*) on to their branches short twigs from the desired varieties. A number of varieties may thus be grown on one tree. Top-grafting is

done in spring after the buds begin to swell. The scions must be kept moist and dormant till the time of grafting.

XIV. IMPROVEMENT OF CULTIVATED PLANTS

It is thousands of years since men in various parts of the world, emerging from the savage state, began to cultivate some of the wild plants which produced fruits or seeds suitable for human food. In the course of ages, by careful cultivation and selection these wild plants have been wonderfully improved.

In some cases the wild parent plants can still be found and recognized; in other cases they seem to have died out or else bear such a slight resemblance to their cultivated offspring that we cannot be sure of the relationship. The wild apple of the old world, from which our cultivated apples have sprung, is a very diminutive fruit. The improvement in size and quality of cultivated roots and tubers, not to speak of the common grains, has been equally remarkable.

There are, no doubt, limits to the capacity of plants to respond to our efforts to change them. I should say that there is little likelihood that we shall ever be able to grow grains of wheat, for instance, as large as apples, or apples equal in size

to pumpkins. Still there is no reason for thinking that the limit has yet been reached. Indeed, as our knowledge of plants increases, so should our power to develop more productive forms of cultivated plants.

Three principal methods of plant improvement are in use. The first method is the selection of the best seeds from the strongest and most desirable plants; by constant selection of the finest seeds a great gain, both in the quantity and quality of the products, may be secured. In order to maintain the improvement which may be reached by this method it is necessary to keep on selecting the best seed year after year. If this is not done, many of the poor seeds or seeds from the poorer plants, will be sown and their offspring will gradually crowd out the better plants.

A second method consists in selecting a single plant which shows desirable qualities in a higher degree than do the individual plants surrounding it. Seeds from this plant are sown by themselves. If these seeds produce plants having the same desirable qualities as the parent plant, seeds of this generation are sown by themselves, and the process is continued until a new variety is established which will breed true from the seed.

The third method depends on the production of *hybrids*. We have learned that every flowering plant is developed from an egg-cell, and that this

egg-cell is formed by the union of a germ-cell which descends the pollen tube with another germ-cell in the ovule (the young seed). If the pollen grain comes from a plant of a different variety or species from that of the plant which it fertilizes, the egg-cell will develop into a plant which will resemble in some respects each of the two plants which had a share in producing the egg-cell.

It is evident, then, that if we find two related plants, each of which has some desirable characteristics not possessed by the other, we may succeed in uniting these features in one plant by transferring the pollen of one to the stigma of the other. If this *cross-fertilization* takes effect, the seed-plantlet will develop into a plant resembling in some respects each of the parent plants. This new plant is called a *hybrid*, and if it proves to be superior in any way to its parent plants, it may be propagated — usually from seeds, sometimes from buds.

Upon thinking over this matter of plant improvement you will see that even children might do something, by selecting the best seeds or the seeds of the best plants, to help in increasing the food supply of the home and of the world, and in this way contribute to human comfort and happiness.

XV. A LESSON ON TILLAGE

Country boys and girls are more or less familiar with the various methods of cultivating the land, and most city children must have seen these operations going on, if only from a railway carriage. Let us consider the use of all this hard work.

The plough and harrow are used in preparing the soil before the seed is sown. The plough goes deep down into the ground, turns the upper soil over and pulverizes it somewhat. It buries manure, weeds and stubble. The harrow with its many teeth pulverizes the soil more thoroughly if not so deeply.

This preparatory cultivation, if well done, is of great use in several ways. It exposes some of the lower soil to the action of the air. By loosening the soil it makes more room for air and water, both of which are needed by the roots of the plants. By breaking the soil up into separate particles it increases greatly the amount of surface exposed to the air and water. The air and water act chemically on substances in the soil, so that more soluble substances necessary for the growth of plants are formed there, and dissolve in the soil water. The loosening of the soil makes it easy for the rootlets to penetrate in all directions in search of food materials. Stirring the soil also permits the surplus water after rains to drain downward

into the earth. In this way ploughing aids in warming the soil. Wet soils are always relatively cold, for the heat of the sun is largely used in evaporating the water instead of in warming the soil.

In all cases in which the young plants are far enough apart to allow of it, cultivation to the depth of from two to four inches should be carried on throughout the season, or till the size of the plants interferes with the process. Repeated cultivation is necessary to kill the weeds and to maintain a loose soil mulch, which hinders the evaporation of water from the soil below during dry weather, and retains it for the thirsty rootlets. Stirring the surface soil breaks up the small continuous spaces through which the water from below would rise by capillary attraction, so that the water cannot escape so rapidly into the air, and thus be lost to the roots of the plant.

The roller is often used to crush clods of earth. It is useful in loose soils for compacting the earth somewhat. This helps to form small tubes in the loose soil, by which the water from below may rise to supply the roots of the young plants.

In a small garden the spade may do the work of the plough, while the rake and the hoe are used instead of the harrow and the horse cultivator. The soil about the seed, and about the little plants which are being set out in the garden, may be

compacted with the back of the hoe or by the pressure of the feet or hands of the gardener, thus bringing the soil particles into close contact with the roots of the young plants.

XVI. ROTATION OF CROPS

Few soils will produce a good crop of the same plant year after year for a long period. To keep up the productiveness of the soil it is necessary to change the crop, that is, the species of plant, from time to time.

It has been supposed that the failure of a soil after a time to produce good crops of the same plant—wheat for instance—continuously, is because some of the substances in the soil which are essential to the satisfactory growth of the plant have been exhausted, or at least so greatly reduced in amount that there is not enough left to permit of a good yield. Some investigators claim, however, that the failure of the crop in such cases is often due to the fact that the roots of plants excrete into the soil substances which are poisonous to the plant which produces them.

A change of crop may be needed in order that weeds which have established themselves in the soil may be destroyed. For this purpose a crop that can be cultivated throughout the summer

should follow one which did not allow of continued cultivation.

Again, some plants send their feeding roots more deeply into the soil than others, and draw their food from a greater depth. Such plants may be planted in succession to shallow-rooted ones.

Clover is very largely employed in keeping up the supply of nitrogen in the soil. If you dig up a clover plant (and the same might be said of peas, beans, and any other plants of the legume-bearing family), you may find on its rootlets small nodules or tubercles. Each of these tubercles has been found to be the home of a colony of bacteria. These bacteria have the power of extracting nitrogen out of the air which occupies the spaces between the particles of soil, and of causing this nitrogen to unite chemically with other elements. The clover plant then absorbs this nitrogen compound out of the tubercles and uses it in the manufacture of proteids, which, as you know, are compounds containing nitrogen. So the stem and roots of the clover contain a good deal of combined (*fixed*) nitrogen which was obtained directly from the air by the bacteria of the tubercles. Consequently, when the whole clover plant or its roots are ploughed under they enrich the soil with a considerable amount of nitrogenous matter; hence it is that clover has come to find a place in most rotations.

Other plants besides clover are sometimes grown, to be ploughed under while green that they may by their decay add humus to the soil.

Different rotations are adopted to suit different conditions of soil, climate and market. These are some common three-year and four-year rotations :

- (a) Wheat, clover, potatoes.
- (b) Clover, corn, wheat.
- (c) Clover, corn, potatoes, wheat.
- (d) Corn, wheat, clover, grass.

Each farmer, however, must determine for himself the rotation which is most suitable for the different soils found on his farm, and for the various crops he finds it most profitable to raise.

XVII. HOME AND SCHOOL GROUNDS

A home or a school in which love and order reign is a happy one, no matter how bare its walls or how barren and brown its surroundings. Yet even a happy home or school is made more attractive, and dearer to the hearts of its members, if the grounds about it are tastefully adorned with trees, shrubs, flowers and grassy lawns. The plainest cottage is made home-like by a few vines creeping over its door and roof, and a few flowers blooming beneath the windows.

In beautifying the home and school grounds nature will be found the best guide. In the woods, along the streams, about the borders of the meadows, here and there, may be seen natural groupings of trees and shrubs, ferns, and low flowering plants, which impress themselves on our memories for their beauty and fitness. These natural pictures will furnish material for an imaginary picture which may be realized about the home and school.

A grassy lawn will form the basis of the plan. If the space is small, the trees must be planted in straight rows, or singly in the corners of the lot; but if there is room enough, it is better—because more natural—to plant them in groups. Trees should, as a rule, be set 20 or 30 feet apart; but they may be planted more closely at first, with a view to thinning them out when they become large enough to interfere with each other's best development. If possible, space should be found for a few fruit trees belonging to varieties hardy in the district. A row of evergreen trees will often afford welcome protection from cold winds.

Shrubbery may be worked in around the lawn, in vacant nooks and corners, and at bends in the paths. Suitable spots can be found for planting ferns from the woods, and some of the wild flowering plants which adorn the meadows and groves in spring and summer. On either side of the

pathways may be set such cultivated perennial plants as lilies, irises, peonies, dahlias, etc.

If young trees are transplanted from the neighboring woods they should be taken up carefully, so as to save as many rootlets as possible. The holes in which to set them may be dug in advance, so that the trees may be set out at once. If trees are obtained from a nursery they will probably be in good condition for planting out when they arrive. It is very important that the rootlets should not be allowed to become dry.

In most cases the tops and branches should be cut back to balance the loss of roots. If this is not done there will be so many leaves produced that the water will evaporate from the leaves faster than the roots can supply the loss, and the tree will dry out and die.

The roots should be covered with good soil, well shaken and packed down. Before the last of the soil is put in, saturate the earth about the roots with water. The last layer of soil spread on should be left and kept loose to hinder evaporation from below. In dry seasons the soil about the roots may occasionally need to be saturated with water. When necessary a guard of stakes or palings fastened together should be set around each tree.

Children would find it very interesting to grow some of the native trees from seed, in window boxes, or in plots out of doors, to be afterwards

transplanted in the home or school grounds or along the road.

As the trees grow they may need occasional *pruning*. Trees produce so many buds that the number of branches is liable to become too great. In the competition between the branches for food and light, those which gain the lead do not always add to the beauty or to the productiveness of the tree; hence the advantage of judicious pruning. You should never, in pruning, cut off or cut back a branch until you have considered what advantage will follow, either in stimulating the growth of other branches or in improving the form of the tree.

We have considered the beautifying of the home and of the school grounds together, for the same principles apply to both. The school takes the place of the home for several hours each school day. The school should aim to be an ideal home for the children for that time, but as there are usually more children in the school than in the family home, the school grounds need to be larger—much larger than they usually are.

In planting trees and shrubs on the school grounds, the different kinds of native trees should be represented as far as space permits. Some trees and shrubs whose fruits afford food for birds should also be planted. A well-selected variety of trees and other plants will make the school grounds a rich field for nature studies.

THE PHYSICS OF SOME COMMON TOOLS

BY

CARLETON J. LYNDE, B.A., PH.D.

PROFESSOR OF PHYSICS, MACDONALD COLLEGE, QUE.

Introduction

TO THE TEACHER.—The work in this chapter deals with tools which the pupils have all used or seen used. It is hoped that they may learn that the use of each of these tools is governed by law. In learning this, they will the more readily realize that in nature there is law and order everywhere.

It cannot be too strongly urged that the pupils be allowed to obtain this knowledge at first hand, by making the experiments themselves, with help and guidance from the teacher, of course, but the actual work should be done by the pupils.

Apparatus.—The apparatus to be purchased by the school need not exceed in cost one or two dollars, as the greater part of it may be borrowed from the homes of the pupils or from the nearest hardware store. A list of the apparatus needed is as follows:—

To be purchased or borrowed: One spring balance 6 inches long, weighing to 25 lbs., with divisions representing pounds; 1 spring balance 4½ inches long, weighing to 4 lbs., with divisions representing ounces; 1 yard stick, 1 ball of stout cord, 1 thermometer, 1 support, as shown in the figures. This support may be made by

some of the boys or by a carpenter. It is made of 2 by 4 pine and is 6 feet high ; in place of it there may be used a staple driven into the ceiling, with a rope attached to it, the lower end of the rope being 6 feet from the floor, and having a loop to which the cord and spring balance are attached in the different experiments. One set of weights, consisting of three one-pound, two two-pound, one five-pound, one ten-pound, and one twenty-five-pound weight. The simplest way to get these weights is to make bags of close woven cloth and fill them with coarse dry sand or gravel to the required weight. Tie them securely and leave a 3-inch loop in the cord, in order that they may be readily attached to the different pieces of apparatus.

To be borrowed when needed : Shovel, pitchfork, crowbar, wheelbarrow, windlass, pulleys, jackscrew.

Weather observations.—One method of training pupils to habits of observation is to ask them to keep a daily record of the weather. The observations should be made at about the same time each day, and recorded in a book. From time to time these records should be examined, to learn the weather to be expected at certain seasons, when the wind is from a certain direction, etc. A convenient form of record is to divide the page into five columns with the following headings :—Date: Temperature: Direction and Force of Wind: Sunshine, Cloudy, Rain or Snow: Remarks: The apparatus needed is a common Fahrenheit thermometer, which should be fastened outside of a window on the north side of the school, about eight or ten inches from the glass, and so as to be easily read without opening the window. If it is within the means of the school, it is very important to have a mercury or aneroid barometer, as by means of it very accurate weather forecasts can be made. For recording these observations a sixth column would be needed in the record.

It will be found after a time, that the pupils who make observations on this phase of nature develop the habit of observation towards all phases of nature. They are very keen to notice changes in the weather, and also they are very keen in their observations of flowers, trees, grains, roots, animals, etc. This is a valuable habit to develop in young people, and when once developed is never wholly lost.

Notebooks.—The pupils should be asked to keep a record of the experiments they make in school and at home. For this purpose, a five or ten cent notebook is sufficient, the first eight pages to be reserved for the record of the weather, and the remainder to be used for the results of experiments.

Experiments at home.—The experimental work which the pupils do in their own homes is of even greater value to them than that which they do in the school, because they have only themselves to depend upon. They must think out their problem, plan the experiment, and then make the experiment, without help. This gives them self-reliance, and develops a confidence in their ability to master nature and wrest from her an answer to their questions. It is well to encourage this work in every way, first by helping them to make a start, and then by asking each day for the results obtained in the experiments at home.

TO THE GIRLS AND BOYS.—In this chapter we purpose to study some of the tools which you have all used or seen used, viz., the shovel, pitchfork, crowbar, wheelbarrow, derrick, windlass, pulleys, jackscrew and wheels, and we will try to find the rule or law which governs the use of each one. You will find it very interesting to make experiments of your own at home, and a number of such experiments are suggested in each lesson. All that you will need in the way of apparatus besides the shovel, pitchfork, crowbar, etc., will be a spring balance some

stout cord, a support, some weights and a foot rule or yard stick. You will find that the most interesting experiments are those which you plan for yourselves. In making an experiment you will find it well, before you start, to answer the following questions: What do I wish to find out? How do I propose to do it? And after you have made the experiment, What do my results show?

Lesson I

The Lever.—We are starting out now to study the shovel, fork, crowbar, wheelbarrow, derrick and windlass. In order to understand these it will be necessary to learn something of the ordinary lever.

Let us think of some of the levers that we have used or seen used; for example, the crowbar and shears.

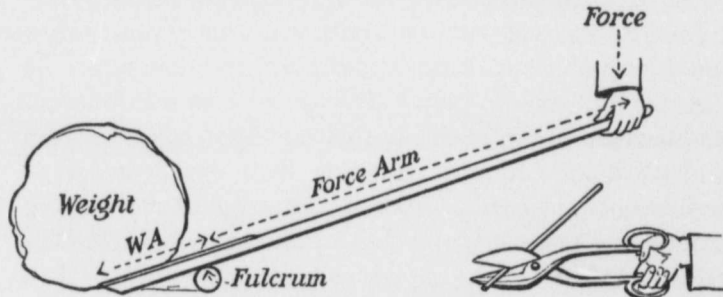

Fig. 1. The Crowbar and Shears.

The Crowbar.—We all know from experience something of the crowbar. For example, if we wish to give a stone the greatest lift possible with a given force, where do we place the fulcrum block? At once you will tell me that we place it as close to the weight as possible. Again, where do we place the hand in order to give the stone the greatest lift possible with a given force? As near the end as possible.

The Shears.—The shears is a double lever. If we were cutting a piece of wire, in what part of the jaws would we place it to use the least force? As close to the rivet as possible.

If we had two pairs of shears of the same design, except that one had long handles and the other short handles, which would we use to cut a very tough substance? The long-handled ones.

Other levers with which we are all more or less familiar are the pump handle, scissors, pliers, the handles of a plough, the levers on mowers, reapers, etc.

We all have a general knowledge of levers then. Now let us make this knowledge more scientific.

We make our knowledge of anything more scientific by doing three things:

1st. By making it exact. That is, we measure everything that has a bearing on the question we wish to decide.

In this case we are studying the lever, and we wish to know the force required to lift a certain weight when we know where the force and weight are with respect to the fulcrum. So we will measure the force, the weight, the distance the force is from the fulcrum and the distance the weight is from the fulcrum.

2nd. By trying to find a rule or law which connects all the quantities measured. In the case of the lever we will try to find a rule or law connecting the force, weight, force arm and weight arm. (See Fig. 1 for meaning of force arm and weight arm.)

3rd. By applying the law to new cases. We will apply the Law of the Lever, when we find it, to the shovel, the fork and the other tools mentioned above.

In Experiment I we will use *measured* weights and *measure* the distances in order to find the *law* of the lever. Then we will *apply* this law to new cases.

Experiment I.—To find the “Law of the Lever.”

Fig. 2. Apparatus: A Yard Stick, Weights, Support.

To find the Law of the Lever we will use a simpler lever than the crowbar or shears. We will use a yard stick, and balance it at the middle. When it is balanced in this way one-half of the weight of the stick just balances the other half, so that we need not consider the weight of the stick in the remainder of the experiment.

1. Balance the yard stick. To do this, attach a string at the middle and adjust it until the stick remains horizontal. Attach the string to the support.

2. Now attach 1 lb. at say 8 in. from the balancing point. Where does 1 lb. balance it? Attach the

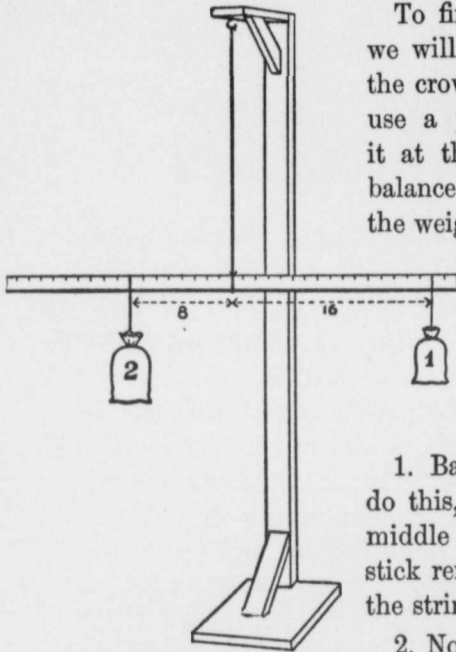
1 lb. at other distances. Where does 1 lb. balance it?

We find in every case that the distances are equal.

3. Attach 1 lb. at 8 in. from the balancing point. Find where 2 lbs. balances it. Attach the 1 lb. at other distances. Find where the 2 lbs. balances it. We find that the 2 lbs. is always half as far from the fulcrum as the 1 lb.

4. Attach 2 lbs. at 12 in. from the fulcrum. Find where 3 lbs. will balance it. Attach the 2 lbs. at other distances. Find where the 3 lbs. balances it. We find that the 3 lbs. is always two-thirds as far from the balancing point as the 2 lbs.

Have you discovered a law connecting the weights and their distances from the fulcrum ?

There are a number of ways of stating this law, and one which some of you have already probably discovered is :
 "The distances are inversely proportional to the weights."

A more convenient way of stating it, and the way that we will use, is:

Weight No. 1, multiplied by its distance from the fulcrum, = weight No. 2 multiplied by its distance from the fulcrum.

For example : in (2) $1 \times 8 = 1 \times 8$
 in (3) $1 \times 8 = 2 \times 4$
 in (4) $2 \times 12 = 3 \times 8$

5. Let us now apply this law :

If we know any three of these terms we can always calculate the fourth.

For example in (4). If 2 lbs. is placed 9 in. from the fulcrum let us use the law to calculate where 3 lbs. must be placed to balance it.

The law is : Weight No. 1, multiplied by its distance from the fulcrum, = weight No. 2 multiplied by its distance from the fulcrum.

Let us represent the unknown distance by "*d*."

Then $2 \times 9 = 3 \times d$ or $3d = 18$
 or $d = \frac{18}{3} = 6$

That is, 3 lbs. 6 in. from the fulcrum will balance 2 lbs. 9 in. from the fulcrum on the other side. Try it.

6. Make other applications of the Law of the Lever, as in 5.

Conclusion: The "Law of the Lever" is:

Weight No. 1, multiplied by its distance from the fulcrum, = weight No. 2 multiplied by its distance from the fulcrum.

Suggestions for experiments at home :

1. Repeat 1, 2, 3, 4, 5 and 6 with any straight stick.
2. Does the Law of the Lever apply to a teeter? Let two boys weigh themselves. Balance a teeter and mark off 1 foot spaces on both sides from the balancing point. If boy No. 1 stands with the centre of his feet just over the 4 feet mark, calculate where boy No. 2 must stand to balance him. Try it.

Exercises

1. State the Law of the Lever.
2. If a yard stick is balanced at the middle, and 2 lbs. is attached 8 in. from the middle, where will 1 lb. balance it? Where will 4 lbs. balance it? Make a sketch of each.
3. If 3 lbs. is attached 4 in. from the balancing point, where will 1 lb. balance it? Where will 2 lbs. balance it? Make a sketch of each.
4. In a pump handle, the pin is 6 in. from the point at which the piston is attached, the hand applies the force $2\frac{1}{2}$ ft. from the pin. If the piston and the water lifted in one stroke weigh 50 lbs., what force must the hand apply to just balance this force? (Leave out of consideration the friction and the weight of the handle.)
5. A boy weighing 100 lbs. is 3 feet from the balancing point of a teeter. Where must a boy weighing 75 lbs. stand to balance him?
6. A crowbar has 100 lbs. attached at the point. The fulcrum block is 1 foot from the point, and the force is applied 4 feet from the fulcrum; what force will just balance the 100 lbs. if we leave out of account the weight of the bar? Make a sketch.

Lesson II

Record the weather conditions.

What experiments did you make at home? What were your results?

In the last lesson we experimented with measured weights and lengths to find the Law of the Lever, and then we made one or two applications of this law. In the lesson to-day let us apply the Law of the Lever to the shovel.

When a man is using a shovel left-handed, the left hand grasps the shovel near the shovel pan, and the right hand is at the end of the handle. In this case, when there is a load in the pan, the left hand is lifting up and the right hand is pushing down. (See figure.)

Let us use the Law of the Lever to find out the force that the right hand must exert to balance a certain weight on the pan. We will think of the left hand as the fulcrum.

Experiment II.—The Shovel.

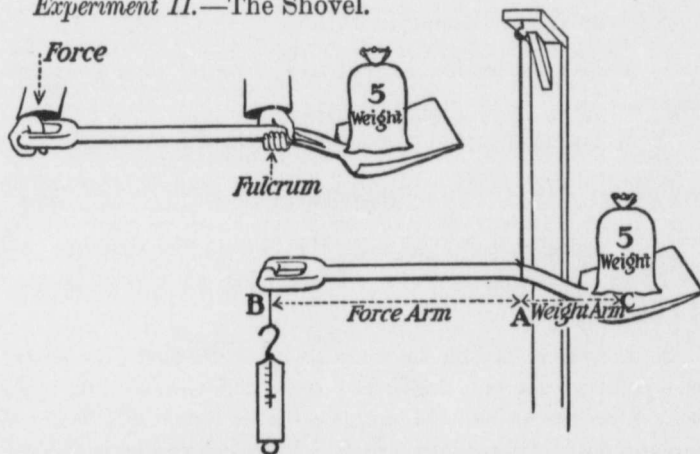

Fig. 3. Apparatus: Shovel, Weight, Spring Balance, Support.

To find the force at B that will support a certain weight at C :

1. Balance the shovel without the weight or spring balance. To do this attach the cord of the support at such a point A that the shovel handle will remain horizontal. A is the fulcrum.

2. Measure the force arm AB and the weight arm AC (C is the centre of the pan). Use the Law of the Lever to calculate the force at B that will support 5 lbs. placed with its centre over C.

When you have found this force by calculation, find it experimentally. To do this, place 5 lbs. with its centre exactly over C, and attach a spring balance at B and read the force indicated. Does this force agree with that obtained by calculation? Does the Law of the Lever apply to the shovel?

3. Use some other weight at C. Calculate the force and then find it experimentally.

Suggestions for experiments at home :

1. Make experiments similar to 1, 2 and 3 with your own shovel.

2. Make experiments of your own with the shovel.

Exercises

1. A shovel is balanced as in the figure ; the distance AB is 24 in., and AC is 8 in. What force at B will balance 12 lbs. at C?

2. A man is prying up a rock with a crowbar ; he places the point of the bar under the rock, and the fulcrum block 4 in. from the point. He applies all his force—150 lbs.—at a point 60 in. from the fulcrum. How many pounds upward lift does he give to the rock? Leave out the weight of the bar. Make a sketch.

3. A boy is fishing, and is holding his pole so that the left hand is 6 ft. from the end where the line is attached and 3 ft. from the right hand, which is at the butt of the pole. He catches a fish weighing 2 lbs. What force must the right hand exert to hold it? Leave out the weight of the pole. Make a sketch.

4. A woman is sweeping with a broom, which she is holding in such a way that the lower hand is 3 ft. from the point at which the broom touches the floor, and $1\frac{1}{2}$ ft. from the upper hand. If the drag on the floor is equal to a pull of 1 lb., what force must the upper hand exert? Leave out the weight of the broom.

Lesson III

Record the weather conditions.

What experiments did you make at home? What results did you obtain?

In Lesson II we applied the Law of the Lever to the shovel, and found that when the shovel is used left-handed we could calculate the force exerted by the right hand; and we proved our calculation to be correct by making an experiment.

Some of you have probably already asked: "But how much does the left hand lift?" Let us answer this question by considering exercise 1 under Lesson II. In this the force arm is 24 in., and the weight arm is 8 in., and the weight is 12 lbs. You have already found the force at B to be 4 lbs., because

$$F \times 24 = 8 \times 12$$

$$F = \frac{8 \times 12}{24} = 4 \text{ lbs.}$$

In this case the right hand at B exerts 4 lbs. downward, and the weight at C is 12 lbs. The left hand at A lifts against the right hand 4 lbs., and also the weight at C 12 lbs. How much then does the left hand lift? Ans. $12 + 4$ or 16 lbs. In addition to this, if the left hand is at the balancing point A, it must lift the weight of the shovel (4 lbs. is the average weight of a shovel). The left hand lifts how much altogether? Ans. $16 + 4 + 4$ or 20 lbs. Notice in this case the left hand exerts a force of 20 lbs.

and the right hand only 4 lbs., so that when a shovel is being used left-handed, the left hand works much harder than the right ; in this case five times as hard.

In Experiment VIII we will use the shovel again and find *by experiment* how much force the left hand exerts.

Let us now apply the Law of the Lever to the pitchfork.

Experiment III.—The Pitchfork.

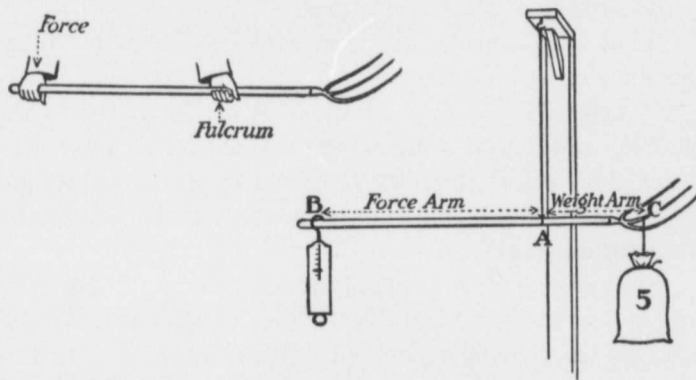

Fig. 4. Apparatus: Pitchfork, Weight, Spring Balance, Support.

To find how much force each hand exerts in using a pitchfork :

1. Balance the pitchfork without the weight or spring balance. To do this attach the cord of the support at such a point A that the fork handle remains horizontal. A is the fulcrum.

To find the force exerted by the right hand :

2. Measure the distance from A to a point B about 2 in. from the end of the handle (*i.e.*, about where the middle of the hand would come if the fork were in use). Measure the distance from A to C, the middle of the centre tine.

Calculate the force at B that will support 5 lbs. attached at C.

Find this force experimentally. To do this, attach 5 lbs. at C and find the force at B with the spring balance.

Does the calculated force agree with that found by experiment? Does the Law of the Lever apply to the fork?

To find the force exerted by the left hand:

3. Calculate this as follows: Find the weight of the fork on the spring balance. Add to this the force at B and the 5 lbs. at C.

Find it by experiment. To do this, attach the spring balance to the support and then attach the cord holding the fork to the spring balance. Now balance the fork again, then attach the 5 lbs. at C and hold the fork at B with the hand. Read the force indicated on the balance.

Does the calculated force agree with that found by experiment?

Suggestions for experiments at home:

1. Make experiments similar to 1, 2 and 3 with a fork at home.
2. Make experiments of your own with a fork.

Exercises

1. A pitchfork is balanced as in the figure; the distance AB is 40 in., and the distance AC is 24 in. What force at B will support 10 lbs. placed at C?
2. If the fork mentioned in exercise 1 weighs 3 lbs., what force must the left hand at A exert?
3. A man is using a shovel left-handed; the left hand is lifting at a point 25 in. from the right hand, and 10 in. from the centre of the pan. There is 15 lbs. on the pan. What force does the right hand exert? Make a rough sketch.
4. If the shovel in exercise 3 weighs 4 lbs., what force does the left hand exert?
5. Is it well for a boy to learn to use a shovel and pitchfork both right-handed and left-handed? Why?

Lesson IV

Record the weather conditions.

What experiments did you make at home? What results did you obtain?

Levers of the 1st, 2nd and 3rd class.

In the levers that we have been studying so far, viz., the crowbar, shears, shovel, fork, etc., notice the

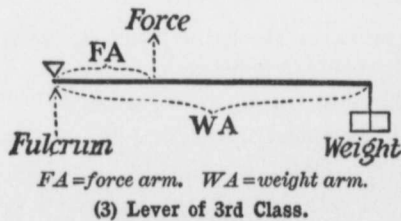
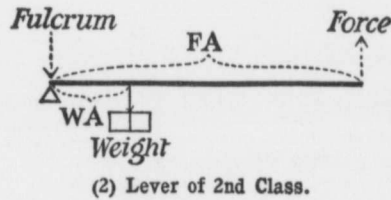
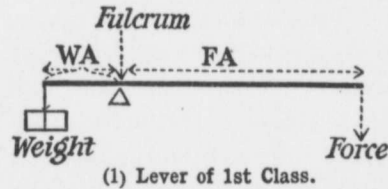

Fig. 5.

position of the fulcrum. Where is it placed with regard to the force and the weight in every case? The fulcrum in every case has been somewhere between the force and the weight. Levers in which this is true are called Levers of the 1st Class. See (1) Fig. 5.

In what other ways might we arrange the force, weight and fulcrum in a lever? One way is as in (2) Fig. 5, in which the fulcrum is at one end, the force at the other, and the

weight between them. Levers of this kind are called Levers of the 2nd Class. Examples: Nut crackers, crowbar, as in Fig. 7; wheelbarrow (as in Fig. 8).

What is the only other possible arrangement of the force, weight and fulcrum? We have it in (3) Fig. 5, in

which the fulcrum is at one end and the weight at the other, with the force between them. Examples: Sugar tongs, shovel, as in Fig. 10; fork, as in Fig. 11.

There are three classes of levers then, and we will find that some of the tools belong to only one class, while others belong to two classes, according to the way they are used, as crowbar 1st and 2nd, shovel and fork 1st and 3rd, etc.

Let us make an experiment now to see whether the Law of the Lever holds for levers of the 2nd class.

Experiment IV.—Levers of the Second Class.

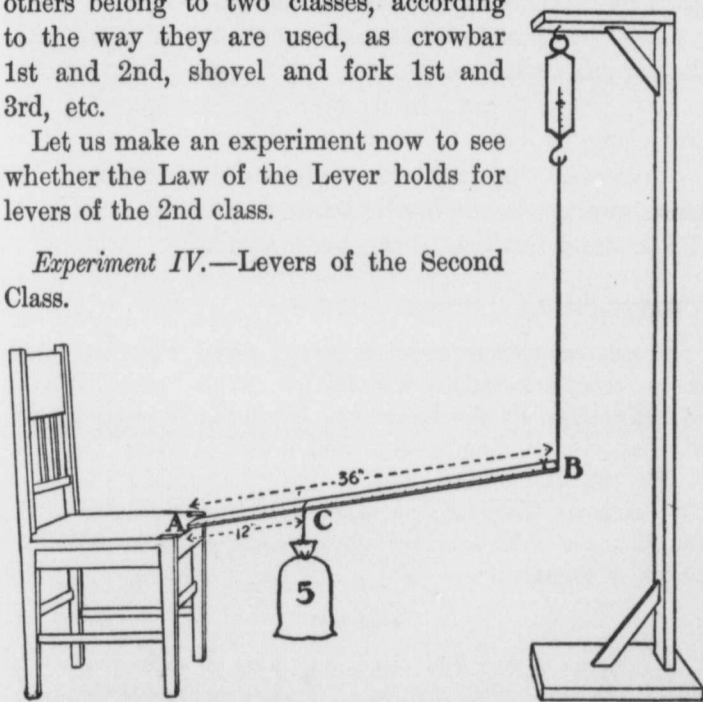

Fig. 6. Apparatus: Yard Stick, Spring Balance, Weight, Support.

To find whether the Law of the Lever holds for levers of the 2nd class :

1. Arrange the yard stick as in the sketch. Find the force indicated on the spring balance, when there is no weight attached to the stick. This is the force necessary to support one end of the stick. Record this force.

2. Measure the force arm AB, and calculate the force that will be necessary to support a weight of 5 lbs. attached 12 in. from the fulcrum A. Add to this the force necessary to support the stick alone. The result is the total force. Find this total force experimentally by attaching the 5 lbs. at 12 in. from the fulcrum.

Does the total force found by calculation agree with that found by experiment?

Does the Law of the Lever apply to levers of the 2nd class?

3. Calculate the total force necessary, if the 5 lbs. is placed some other distances from the fulcrum.

Then find this total force experimentally.

Suggestions for experiments at home :

1. Make experiments similar to 1, 2 and 3 with any stick and a spring balance.

2. Examine all the levers you can find ; for example, on reapers, mowers, pumps, etc., and decide whether they are of the 1st, 2nd or 3rd class.

3. Measure the force arm and weight arm in all the levers you find, and calculate how much weight could be lifted by 20 lbs. of force.

Exercises

1. A lever of the 2nd class, 3 ft. long, is arranged, as in Fig. 6. It takes $\frac{1}{4}$ lb. of force to support one end of the stick alone. What total force will be necessary at B to support 12 lbs. placed 1 ft. from the fulcrum ?

2. What would be the total force necessary in exercise 1, if the 12 lbs. were placed $1\frac{1}{2}$ ft. from the fulcrum ?

3. What would be the total force necessary in exercise 1, if the 12 lbs. were placed 2 ft. from the fulcrum ?

4. A crowbar, 5 ft. long, is arranged, as in Fig. 6. It takes 6 lbs. of force to support one end when there is no weight

on the bar. What total force will be necessary to support 100 lbs. placed 1 ft. from the fulcrum ?

5. What will be the total force in exercise 4, if the 100 lbs. is attached $1\frac{1}{2}$ ft. from the fulcrum ? Make a sketch.

Lesson V

Record the weather conditions.

What experiments did you make at home ? How many levers did you examine ? Of what class were they ? What were the results of your calculations as to the weight that could be lifted by 20 lbs. of force ?

In Lesson IV we experimented with a simple lever of the 2nd class, and found that the Law of the Lever applied to it. Let us to-day experiment with the crowbar. In Lesson I (Fig. 1) we have a crowbar when it is used as a lever of the 1st class. In Fig. 7 below it is being used as a lever of the 2nd class. What is the difference ?

Experiment V.—The Crowbar.

To find whether the crowbar obeys the Lever Law :

1. Arrange the crowbar as in the figure. The point is the fulcrum, and the spring balance exerts a force upwards. Measure the force arm, *i.e.*, the distance from the fulcrum to the force. Adjust the cord until this is some whole number of inches.

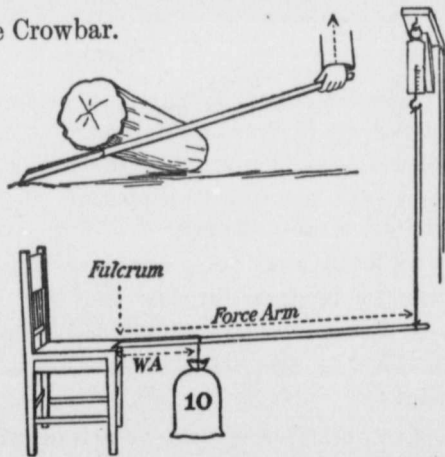

Fig. 7. Apparatus : Crowbar, Chair, Weight, Spring Balance, Support.

Record the force necessary when there is no weight on the bar.

2. Calculate the total force that will be required if 10 lbs. is placed 12 in. from the fulcrum.

Find the force by experiment. Does the crowbar obey the Lever Law?

3. Calculate the total force necessary if the 10 lbs. is placed at some other distance from the fulcrum. Find the force by experiment. Does the crowbar obey the lever law?

Suggestions for experiments at home :

1. Make experiments similar to 1, 2 and 3 with your own crowbar.

2. If you have a crowbar, a spring balance weighing up to 25 lbs., and a strong support for the point of the crowbar, how could you arrange them so as to weigh a man weighing 200 lbs.? Make a drawing of it.

Exercises

1. A crowbar is arranged as in the figure. The force is applied 60 in. from the fulcrum; it takes 6 lbs. of force to support one end when there is no weight on it. What is the total force required to support a weight of 120 lbs. placed 5 in. from the fulcrum?

2. What total force would be required if 400 lbs. were placed 3 in. from the fulcrum?

3. In exercise 1. If the total force is 106 lbs., what is the lift 4 in. from the point? What is the lift 1 in. from the point?

4. A crowbar is used as a lever of the 1st class. The distance from the fulcrum to the force is 6 ft., and from the fulcrum to the point is 1 in. A man exerts his whole force, 150 lbs. What is the lift at the point? Leave out weight of bar. Make a sketch.

Lesson VI

Record the weather conditions.

What experiments did you make at home? What were your results? What plan have you for weighing the 200 lb. man?

In Lesson V we found that the crowbar obeyed the Law of the Lever. Also we found that one man could lift enormous weights by using the crowbar in the proper manner.

Let us next experiment with the wheelbarrow. Look at the wheelbarrow in the figure below. Where is the weight? Where is the force applied to lift the weight? Where is the fulcrum? What class of lever is the wheelbarrow?

Experiment VI.—The Wheelbarrow.

To find whether the wheelbarrow obeys the lever law:

1. Arrange the wheelbarrow as in the figure. Measure the distance from the fulcrum (the axle) to the points where the cord is attached. Make this distance a whole number of inches.

Record the force necessary to support the handles of the wheelbarrow when there is no weight on it.

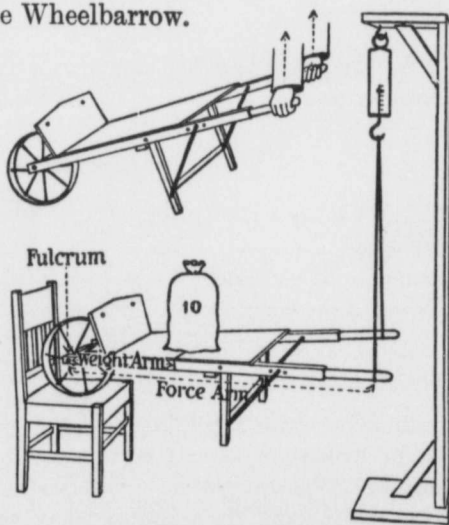

Fig. 8. Apparatus: Wheelbarrow, Weight, Spring Balance, Chair, Support.

2. Calculate the total force that will be necessary if 10 lbs. is placed 15 in. from the fulcrum. Find this total force experimentally.

Does the calculated total force agree with that found experimentally?

Does the wheelbarrow obey the lever law?

3. Calculate the total force that will be necessary if the 10 lbs. is placed at some other distance from the fulcrum. Find this total force experimentally.

Does the wheelbarrow obey the lever law?

Suggestions for experiments at home:

1. Make experiments similar to 1, 2 and 3 with your own wheelbarrow.

2. Tie the string nearer to the axle, *i.e.*, make the handles shorter. Is more or less force required on the balance? Why?

3. Make the handles longer by tying on extra pieces. Is more or less force required on the balance? Why?

Exercises

1. It takes 4 lbs. to support the wheelbarrow handles when no weight is on it. The distance from the force to the fulcrum is 50 in., and 20 lbs. is placed 15 in. from the axle. What is the total force? Make a sketch.

2. What would be the total force in (1), if the 20 lbs. were placed 25 in. from the axle?

3. If we made the handles of the barrow 1 foot longer, *i.e.*, 62 in. instead of 50 in., what would be the total force when 20 lbs. is placed 25 in. from the fulcrum, the force necessary to support the handles when there is no load being $3\frac{1}{2}$ lbs.?

4. What is the advantage of having longer handles on the wheelbarrow?

Lesson VII

Record the weather conditions.

What experiments did you make at home with the wheelbarrow? What results did you obtain?

In Lesson IV we took up levers of the first, second and third class, and we learned that levers of the third class are those in which the fulcrum is at one end and the weight at the other, and the force somewhere between. Let us to-day experiment to see whether the lever law applies to this last class of levers.

Experiment VII.—Levers of the Third Class.

To find whether the lever law applies to levers of the third class :

1. Attach the spring balance as in the figure, 1 foot from one end of the yard stick ; hold this end down on the table. This end is the fulcrum.

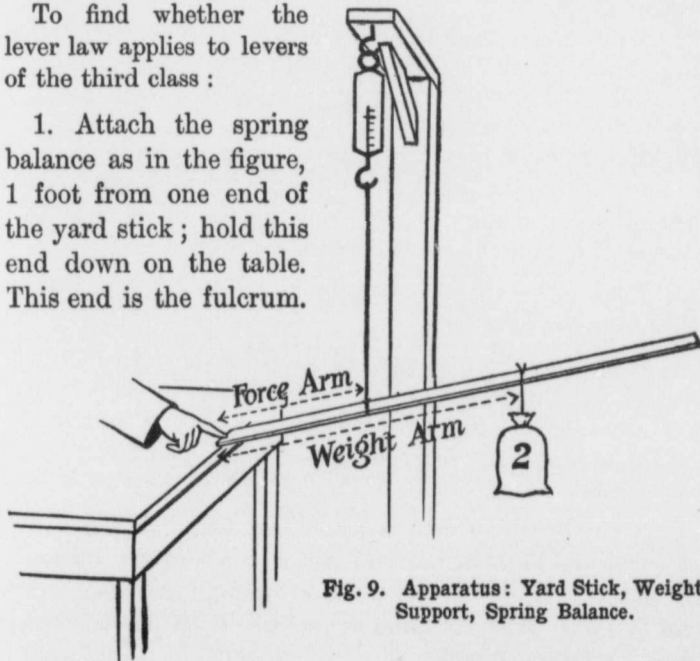

Fig. 9. Apparatus: Yard Stick, Weight, Support, Spring Balance.

Record the force necessary to support the lever when there is no weight on it.

2. Calculate the total force that will be necessary if we place 2 lbs. 2 feet from the fulcrum. Find it experimentally. Does the calculated force agree with that found by experiment? Does the lever law apply to levers of the third class?

3. Calculate the total force that will be necessary if 2 lbs. is attached 3 feet from the fulcrum. Find this total force by experiment. Does the Law of the Lever apply to levers of the third class?

Suggestions for experiments at home :

1. Make experiments similar to 1, 2 and 3 with any straight stick.
2. Make experiments of your own with a lever of the third class.

Exercises

1. If a lever of the third class is arranged as in sketch, the force being attached 1 foot from the fulcrum, what total force will be necessary to support 2 lbs. at 18 in. from the fulcrum, if it takes 6 ozs. to support the lever alone!

2. What force will be necessary in (1) if 2 lbs. is placed $2\frac{1}{2}$ ft. from the fulcrum?

3. If the force is attached 15 in. from the fulcrum, in a lever of the third class, and it takes 5 ozs. to support the lever alone, what total force will be necessary in each case, if 3 lbs. is placed in succession 20 in., 25 in. and 30 in. from the fulcrum?

4. A boy is fishing with a pole 6 feet long; he holds the pole with one hand at the end of the pole and the other in the middle. If he catches a fish weighing 1 lb., what force must he exert with the hand at the middle to lift the fish? Leave out weight of pole.

5. A woman is sweeping with a broom 4 feet long. She holds it with one hand at the end and the other at the middle.

If she sweeps so that the drag on the floor is $\frac{1}{2}$ lb., what force must the hand at the middle exert? Leave out weight of broom.

6. In levers of the third class is the force less than, or greater than, the weight?

7. To what two classes of levers does the shovel belong?

Lesson VIII

Record the weather conditions.

What experiments did you make at home with a lever of the third class? What were your results?

In the last lesson we experimented with a lever of the third class, *i.e.*, one in which the force is applied somewhere between the fulcrum and the weight. In levers of the first and second class we found that the force used is always less than the weight lifted. What do you find in the case of levers of the third class? The force is always greater than the weight, is it not? For example, in the shovel and pitchfork, which we will consider as levers of the third class in the next two experiments, the force exerted by the hand nearest the weight is always greater than the weight. We lose—as far as force is concerned—in levers of this class, but we gain in the speed with which the weight is moved, and in convenience.

In Lesson II we considered the shovel as a lever of the first class; in that case we treated the left hand as the fulcrum and found the force exerted by the right hand. Let us to-day experiment with the shovel again, but consider the right hand to be the fulcrum and find the force exerted by the left hand. In this case we are using the shovel as a lever of the third class.

Experiment VIII.—The Shovel as a Lever of the Third Class.

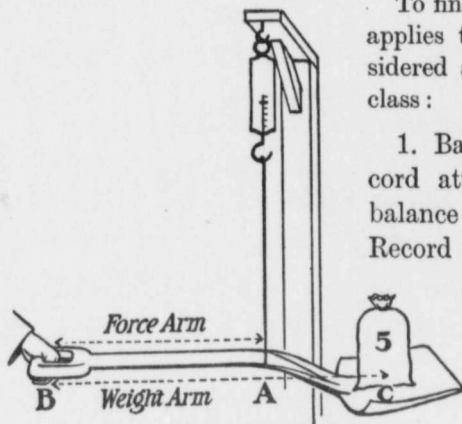

Fig. 10. Apparatus: Shovel, Weight, Spring Balance, Support.

To find whether the lever law applies to a shovel when considered as a lever of the third class :

1. Balance the shovel on the cord attached to the spring balance and the support. Record the force necessary to support the shovel alone.

2. Measure the distance from the fulcrum to the force, *i.e.*, the force arm BA, also the distance

from the fulcrum to the centre of the pan, *i.e.*, the weight arm BC.

Calculate the force at A that will be necessary to support 5 lbs. placed with its centre over C.

Then find this total force experimentally. Hold B with the hand, and place 5 lbs. over C.

Does the calculated force agree with that found by experiment? Does the lever law apply to the shovel when considered as a lever of the third class?

3. Find the force exerted at B, by using the spring balance. Is the force at A equal to that at B, plus the weight at C, plus the weight of the shovel?

Suggestions for experiments at home:

1. Repeat 1, 2 and 3 with a shovel.
2. Make experiments with some other lever of the third class, such as a fish-pole.

Exercises

1. A shovel is suspended as in the sketch. The distance BA is 24 in., the distance BC is 32 in. It takes 4 lbs. force to support the shovel alone. What force at A will be required to support 5 lbs. at C?

2. If we think of the fulcrum being at A in exercise 1, the shovel is a lever of the first class. What force at B will be required to support 5 lbs at C?

3. Consider exercises 1 and 2; the force at B and the weight at C are pulling down. The force at A is lifting up against both of these, and is also lifting the weight of the shovel; therefore, the force at A must be equal to the force at B, plus the weight at C, plus the weight of the shovel. Is it?

4. A shovelful of earth weighs about 12 lbs. If we were using the shovel mentioned in exercise 1, what force at A would be necessary to support a shovelful of earth weighing just 12 lbs.?

5. What force would be necessary at B in exercise 4?

6. Is the force at A equal to that at B, plus the weight of the earth, plus the weight of the shovel?

Lesson IX

Record the weather conditions.

What experiments did you make with a shovel considered as a lever of the third class? What other lever of the third class did you experiment with? What were your results?

In Lesson VIII we experimented with a shovel, thinking of it as a lever of the third class. Let us to-day experiment with a pitchfork in the same way first, and then carry the experiment one step further.

Experiment IX.—The Pitchfork as a Lever of the Third Class.

PART I.—To find whether the Lever Law applies to a pitchfork when considered as a lever of the third class.

Repeat 1, 2, 3 of Experiment VIII, using the fork instead of the shovel.

PART II.—In all the experiments that we have made so far with the shovel

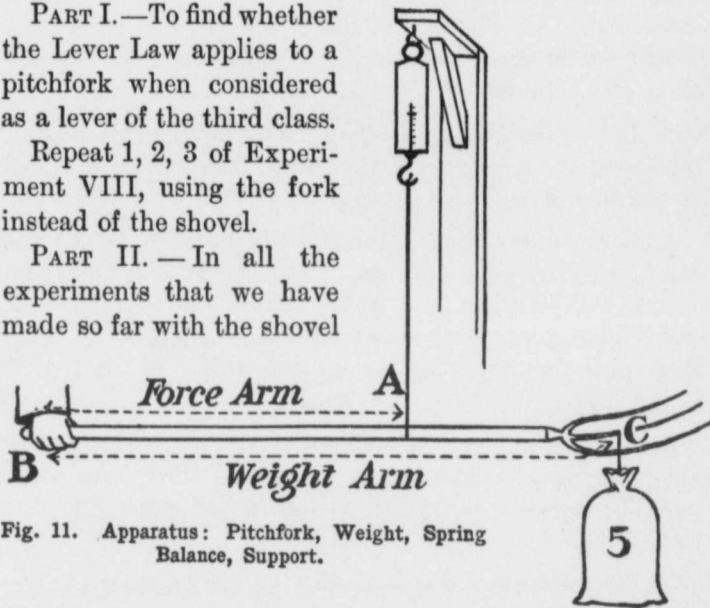

Fig. 11. Apparatus: Pitchfork, Weight, Spring Balance, Support.

and the pitchfork in Experiments II, III, VIII and IX, we have been very careful to balance the shovel and pitchfork in the first part of the experiment. We did this in order to simplify the experiment by having all the weight of the shovel and the pitchfork come on the left hand. When we are actually using the shovel or fork left-handed, however, we do not always place the left hand exactly at the balancing point. For example, if we have to carry a very heavy load on the pitchfork, where do we place the hands? We move the left hand closer to the tines, do we not? And the right hand also. Let us investigate a case of this kind.

To find whether the force exerted by each hand is less when they are moved closer to the weight :

1. Move the position of A and of B 1 foot nearer to the tines, Fig. 11 a. Of course the fork is no longer balanced and each hand supports part of its weight.

Keep one hand at B, and record the part of the weight of the fork supported at A.

Fasten the cord to the support and use the spring balance to find the part of the weight of the fork supported at B.

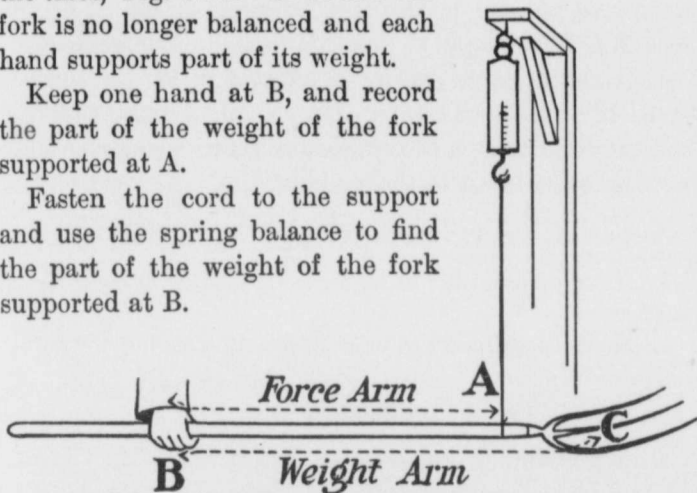

Fig. 11 a. Apparatus : Pitchfork, Weight, Spring Balance, Support.

2. To find the force exerted by the right hand at B when there is 5 lbs. placed at the centre of the middle tine.

Consider the fork as a lever of the first class, with A as the fulcrum. Measure the force arm AB, and the weight arm AC. Calculate the force at B that will support 5 lbs. suspended at C. Subtract from this force the part of the weight of the fork that B supports. This gives the total force at B.

Find this total force experimentally, by attaching the 5 lbs. at C, and using the spring balance at B.

3. To find the force exerted by the left hand at C.

Consider the fork as a lever of the third class with fulcrum at B. Measure the force arm BA and the weight

arm BC. Calculate the force at A that will support 5 lbs. at C. Add to this the part of the weight of the fork supported by A. This gives the total force at A.

Find this total force experimentally. To do this attach the spring balance to the cord, suspend 5 lbs. at C, and hold B with the hand. Read the force on the balance.

4. Are the forces exerted at B and at A less than in Part I of this experiment? Do we understand now why it is easier to carry a heavy load on a fork or shovel when the hands are closer to the weight?

Suggestions for experiments at home :

1. Make experiments as in Part II, placing A in different positions.
2. Make experiments of your own with a fork.

Exercises

1. A pitchfork is balanced as in Fig. 11. The distance BA is 3 feet; the distance BC is 5 feet. It takes 3 lbs. to support the fork alone. What is the total force at A required to support 5 lbs. attached at C?

2. If we think of the fulcrum being at A in exercise 1, the fork is a lever of the first class. What force at B will be required to support 5 lbs. at C?

3. Is the total force at A equal to the force at B, plus the weight at C, plus the weight of the fork?

4. In exercise 1, A and B are shifted 1 foot nearer to the tines; the weight of the fork supported at A is $2\frac{1}{2}$ lbs., and at B $\frac{1}{2}$ lb. What force must the right hand at B exert to support 5 lbs. at C?

5. In exercise 4, what total force at A is necessary to support 5 lbs. at C?

6. Are the forces exerted at B and A, exercises 4 and 5, less than those exerted at B and A, exercises 1 and 2? Is it easier to lift a weight when the hands are closer to the tines?

Lesson X

Record the weather conditions.

What were the results from your experiments at home with the pitchfork?

More about Levers.—In Lesson I we experimented with a simple lever, the yard stick, with two weights, and found the lever law to be “weight No. 1 multiplied by its distance from the fulcrum = weight No. 2 multiplied by its distance from the fulcrum.” Let us to-day experiment with the same lever and find how we would state the lever law to include a number of weights on each side of the fulcrum.

Experiment X.—The Lever.

To state the Lever Law when applying it to a lever with a number of weights on each side:

1. Balance the yard stick. Place 1 lb. 6 in. from fulcrum and 1 lb. 10 in. from the fulcrum on same side. Find experimentally where 1 lb. will balance them. What is the law?

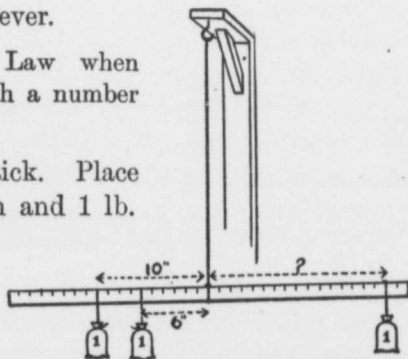

Fig. 12. Yard Stick, Weights, Support.

2. Place 1 lb. at 6 in. from the fulcrum and 2 lbs. at 10 in. from the fulcrum on the same side. Find experimentally where 2 lbs. will balance them. What is the law?

Have you found the law? May it be stated as follows: Find the product of each weight by its distance from the fulcrum, then “the sum of the products on one side of the fulcrum equals the sum of the products on the other”?

Try this law in the following cases :

3. If 1 lb. be placed 4 in. from the fulcrum and 2 lbs. 9 in. from the fulcrum on the same side, calculate where 2 lbs. will balance them. Try it experimentally. Does the law hold ?

4. If 1 lb. be placed 3 in. from the fulcrum and 2 lbs. 15 in. from the fulcrum on the same side, and 2 lbs. 8 in. from the fulcrum on the other side, calculate where 1 lb. will balance the lever. Try it experimentally. Does the law hold ?

Suggestions for experiments at home :

1. Arrange a straight stick and spring balance as a lever of the second class. Use two or three weights. Find whether the force multiplied by its distance from the fulcrum equals the sum of the products obtained by multiplying each weight by its distance from the fulcrum.

2. Make the same experiment with the stick and spring balance arranged as a lever of the third class.

Exercises

1. A yard stick is balanced at the centre. On one side is 2 lbs. 6 in. from the fulcrum, and 1 lb. 8 in. from the fulcrum. Where must 2 lbs. be placed to balance the lever? Make a sketch.

2. If 3 lbs. be placed 6 in. from the fulcrum and 2 lbs. 10 in. from the fulcrum on the same side, and 4 lbs. is placed 6 in. from the fulcrum on the other side, where must 1 lb. be placed to balance the yard stick? Make a sketch.

3. A yard stick is arranged as a lever of the second class, with the fulcrum at one end and the force at the other. 6 lbs. is placed 8 in. from the fulcrum and 4 lbs. 24 in. from the fulcrum. What force is necessary to balance them? Neglect the weight of the stick. Make a sketch.

4. Two boys are carrying 50 lbs. tied to a pole 7 ft. long. The pole weighs 6 lbs. Each boy has his shoulder 1 foot from an end of the pole. If the weight is attached 2 ft. from the shoulder of the boy in front, how much is each boy carrying? Make a sketch. [NOTE.—To calculate what the second boy is carrying, consider the shoulder of the boy in front to be the fulcrum, and treat the bar as a lever of the second class. Reverse the process to find what the boy in front is carrying.]

Lesson XI

Record the weather conditions.

What were your results with levers of the second and third class with two or more weights?

The Derrick.—In the experiment to-day let us work with a derrick. It is not practicable to work with a large derrick, so let us make a small one with a yard stick as in the figure below. We know that a derrick is used for lifting and moving heavy weights; the swinging arm AB is called the boom, the weight hangs from B, the force is applied along BE, and the fulcrum is at A. Evidently, then, the derrick is a lever of some kind. Let us decide what to take as the force arm and weight arm. In all the levers that we have been studying, the force has been acting vertically upwards or downwards. For example, see Figs. 2, 3, 4 and 5. In each of these, what is the angle between the force arm and the direction along which the force acts? Always a right angle, is it not? In the case of the derrick, then, the force arm is the perpendicular distance from the fulcrum A to the line along which the force acts; *i.e.*, the force arm is AD at right angles to BE. Similarly, the weight arm is the perpendicular distance from the fulcrum to the line along which the weight acts; *i.e.*, AB in (1) and AF in (2).

Experiment XI.—The Derrick.

Fig. 13. Apparatus : Yard Stick, Spring Balance, Weights, Support.

To find whether the Lever Law applies to the derrick :

1. Arrange the derrick as in (1), the boom being horizontal with 5 lbs. attached at B. Measure the force arm AD and the weight arm AB. Calculate the force which it is necessary to exert along BE to support 5 lbs. at B ($\text{Force} \times \text{AD} = 5 \times \text{AB}$). Find this force experimentally as follows: Read the force indicated on the spring balances when the 5 lbs. is attached at B, then remove the 5 lbs. and find the force necessary to support the boom alone. The difference between these readings is the force. Does the calculated value of the force agree with that obtained by experiment?

Does the Lever Law apply to the derrick?

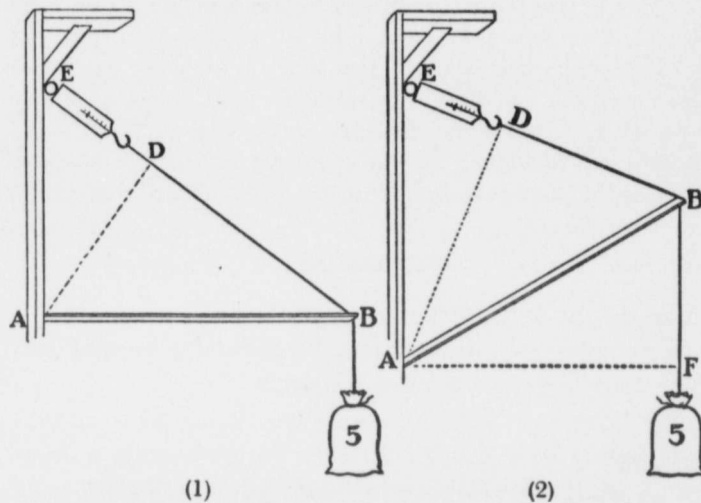
2. Arrange the derrick as in (2). Measure the force arm AD and the weight arm AF. Calculate the force that will support 5 lbs. attached at B.

Find the force experimentally as in (1). Does the calculated value agree with the experimental? Does the Lever Law apply to the derrick?

Suggestions for experiment at home:

Arrange a derrick as illustrated above and try it in new positions. Measure the force arm and weight arm. Calculate the force, then find it by experiment.

Exercises

1. What class of lever is the derrick? If the force arm AD is less than the weight arm as in (1) it is a lever of the 3rd class. If the force arm is greater than the weight arm, it is a lever of the 2nd class.
2. If the weight arm AB in (1) is 3 ft. and the force arm is 2 ft., what force will support 10 lbs. attached at B? Leave out weight of boom.
3. If a derrick is arranged as in (1) and the boom is 20 ft. long and the force arm is 15 ft., what force will be required to support $\frac{1}{2}$ ton? Leave out weight of boom.
4. If the weight arm AF in (2) is 2 ft. and the force arm AD is $2\frac{1}{2}$ ft., what force will be needed to support 10 lbs. attached at B? Leave out weight of boom.
5. If a derrick is arranged as in (2) and the weight arm is 16 ft. and the force arm is 18 ft., what force will be required to support $\frac{1}{2}$ ton? Leave out weight of boom.

Lesson XII

Record the weather conditions.

What were the results of your experiments at home with the derrick?

The Windlass and Friction.—We are all familiar with some form of the windlass; for example, the one frequently used for drawing water from a well with a chain and

bucket. The force is applied at the crank handle; the weight is the chain, bucket, and water in the bucket. Where is the fulcrum? The centre of the axle or drum, is it not? What class of lever is the windlass? The first class during one half-turn and second during the other. Let us find whether the lever law applies to the windlass.

Experiment XII.—The Windlass and Friction.

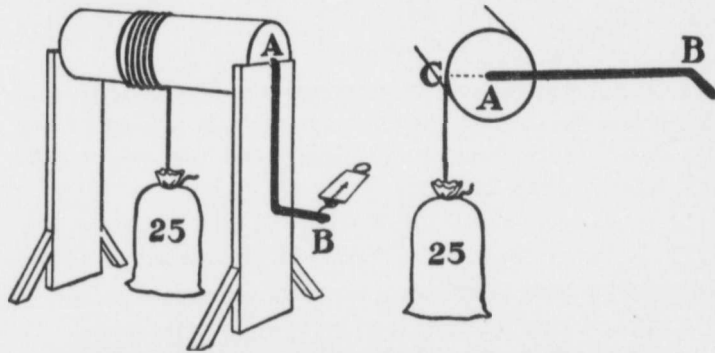

Fig. 14. Apparatus: Windlass, Weight, Spring Balance, Cord.

To find whether the Lever Law applies to the windlass:

1. Measure the force arm, that is, the crank arm AB, and the weight arm; *i.e.*, the radius of the drum AC. Calculate the force necessary at B to support 25 lbs. suspended at C.

Then find the force experimentally. To do this, arrange the windlass as in Fig. 14; that is, have the crank arm hanging down, because in this position the weight of the arm does not affect the experiment.

Attach the weight at C, and find the force on the spring balance attached at B.

Friction.—When you have made this experiment *carefully* you will notice that it takes *less* force than you calculated to *support* the weight. Also if you pull on the crank

handle with the spring balance so as to slowly raise the weight, you will find that it takes a little *more* force than the calculated value.

What is it that makes it harder to *lift* the weight, but easier to *support* it? It is the friction of the axle, is it not? Let us consider friction for a time. Think of all the cases of friction you can. How does the friction always act with regard to the motion you wish to produce? Friction always tends to stop the motion, does it not? This is a Law of Friction; *i.e.*, friction always acts against the motion.

Now that we know this Law of Friction, let us go back to the experiment above. We can find the force that will just support the weight, if there were no friction, as follows:

Pull on the spring balance so that the weight is slowly raised. Record the reading on the balance. Then let the spring balance go back slowly, so that the weight is slowly lowered. Record the reading on the balance.

In the first case the friction is opposing the motion, so that the reading on the balance is equal to the force that would balance the weight, if there were no friction, plus the friction. In the second case the friction is also opposing the motion, so that we have to exert a less pull on the spring balance to keep the motion downward a slow one. That is, the reading on the balance is equal to the force that would just support the weight, if there were no friction, minus the friction. So we have:

Reading I = force that supports weight + friction.

Reading II = force that supports weight - friction.

If we add these together we get:

Reading I + Reading II = $2 \times$ force that would just support the weight, if there were no friction.

$$\text{Force} = \frac{\text{Reading I} + \text{Reading II}}{2}$$

In this way we have eliminated the friction, and have obtained the force that would just support the weight if there were no friction. Does this force agree with the calculated value? Does the lever law apply to the windlass when we eliminate the friction?

2. Make an experiment similar to 1, using a weight of 15 lbs.

Suggestions for experiments at home:

1. Make an experiment with a well windlass. Use a spring balance to weigh the bucket with water in it, and part of the chain. Measure the radius of the drum and the crank arm. Calculate the force that would balance the bucket, then find it by experiment as above.

2. If there is no windlass convenient, make one by using an old broom handle or fork handle for the drum and a piece of lath for crank arm. Experiment with this.

Exercises

1. The radius of the drum is 2 in., the crank arm is 12 in. long; what force will support 25 lbs. if there is no friction?

2. If the radius of the drum is 2 in., and the crank arm is 12 in., what weight can be supported by a force of 30 lbs. if there is no friction?

3. In finding the force experimentally, we find that it takes a pull of 15 lbs. on the spring balance to raise a weight slowly, and only 10 lbs. when we are lowering the weight slowly. What is the force that would just balance the weight, if there were no friction? What is the friction?

4. If the reading on the balance is 8 lbs. when a weight is slowly raised, and 5 lbs. when it is slowly lowered, what is the force that would balance the weight, if there were no friction. What is the friction?

Lesson XIII

Record the weather conditions.

What were the results of your experiments with the windlass at home?

The Law of the Pulley and the Law of Machines.—We are all acquainted with systems of pulleys such as are illustrated in the figure below. Let us examine them to find some relation between the weight lifted and the force. In (1) where there is just one pulley, if we have 10 lbs. of weight and we eliminate the friction, how much force will it take to support it? It will be just 10 lbs., as we shall see later. Notice, however (2). How many ropes are there supporting the weight? How much does each rope support? How much must the force be on the spring balance to support the weight? There are two ropes supporting the total weight of 15 lbs., so each supports just $\frac{1}{2}$ of it, or $7\frac{1}{2}$ lbs., and as the force is pulling against only one of these ropes it will be $\frac{1}{2}$ the weight, or $7\frac{1}{2}$ lbs. if the friction is eliminated.

Again in (3) there are three ropes supporting the total weight of 15 lbs. Each then will support $\frac{1}{3}$ of it, or 5 lbs., and as the force is pulling against only one of the ropes it will be equal to $\frac{1}{3}$ of the weight, or 5 lbs., *i.e.*, if we eliminate the friction.

Similarly in (4) where there are four ropes supporting a total weight of 16 lbs., how much will the force be? The force will be $\frac{1}{4}$ of 16 lbs., or 4 lbs. if we eliminate the friction.

What then is the Law of the Pulley? May it be stated as follows: "If there were no friction, the force that would support a weight on any system of pulleys is equal to the weight divided by the number of ropes supporting the weight"?

Let us test this law experimentally.

Experiment XIII.—PART I.—The Law of the Pulley.

Fig. 15. Apparatus: Pulleys, Weights, Cord, Support.

To test the Law of the Pulley:

In order to decrease the friction it is well to oil the pulley axles and use a stout cord in place of the usual heavy rope.

1. Find the force in (1), Fig 15. We cannot neglect the friction, but we can find the force that would just support the weight if there were no friction, as we did in the last experiment. That is: (a) pull on the spring balance so that the weight is slowly raised. Record the reading on the balance. (b) Decrease the pull so that the weight is slowly lowered, and record the reading on the balance. Then we have:

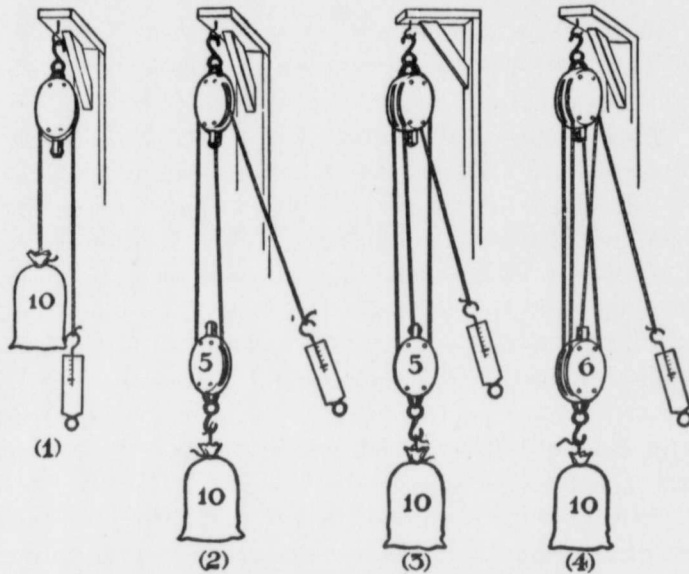
Reading I = force + friction.

Reading II = force - friction.

Adding these we have :

$$2 \text{ Force} = \text{Reading I} + \text{Reading II.}$$

or

$$\text{Force} = \frac{\text{Reading I} + \text{Reading II.}}{2}$$

2. Repeat this with (2), (3), (4), Fig. 15. Does the Law of the Pulley hold ?

PART II.—The Law of Machines.

In (2) Fig. 15 there are two ropes supporting the weight. How far down would we have to pull the rope to which the spring balance is attached, in order to raise the weight 1 foot. How far in (3) and (4), Fig. 15 ?

1. Find by experiment how far the force moves down when the weight is raised 1 foot, with pulley arranged as in (2), Fig. 15.

2. Make the same experiment with pulleys arranged as in (3) and (4), Fig. 15.

We find that in (2) where two ropes are supporting the weight, the force moves 2 ft. to raise the weight 1 foot. When there are three ropes as in (3), the force moves 3 ft. to raise the weight 1 foot, and when there are four ropes as in (4), the force moves 4 ft. to raise the weight 1 foot.

Work.—Work is measured in *foot pounds*. When 1 lb. is raised 1 foot, 1 foot pound of work is done. If 1 lb. is raised 2 ft., 2 foot pounds of work are done ; if 2 lbs. is raised 5 ft., the work done is 10 foot pounds. Similarly, if a force of 1 lb. moves 1 foot, 1 foot pound of work is done, or if a force of 5 lbs. moves 4 ft., 20 foot pounds of work are done.

This leads us to the Law of Machines.

In (2) Fig. 15, $7\frac{1}{2}$ lbs. of force moves 2 ft. to raise 15 lbs. 1 foot. The work put into the pulley is $7\frac{1}{2} \times 2$, or 15 foot

pounds, and the work accomplished is 15×1 , or 15 foot pounds.

Again in (3), 5 lbs. of force moves 3 ft. to raise 15 lbs. 1 foot. Again, the work put into the pulley is 5×3 or 15 foot pounds, and that accomplished is 15×1 , or 15 foot pounds. Similarly in (4) the work put into the pulley equals the work done by it.

This gives us the very important "Law of Machines," viz., if there is no friction, "The work done by a machine is equal to the work put into it."

This law applies to every machine ever made, no matter how simple or how complicated.

In every machine, however, there is always friction, so that the work we get out is always less than the work we put into it. Part is always wasted in friction. We oil machines and use roller and ball bearings to make this waste as little as possible.

Suggestions for experiment at home :

Experiment with any pulleys you have. Show that the force equals the weight divided by the number of ropes supporting the weight when we eliminate friction. Also show that when the weight is raised 1 foot the force must move 2 ft. if two ropes are supporting the weight, or 6 ft. if six ropes are supporting the weight, etc.

Exercises

1. Draw systems of pulleys in which 1, 2, 3, 4 and 5 ropes are supporting the weight.
2. In a system of pulleys in which two ropes are supporting the weight, the lower block weighs 5 lbs., and 25 lbs. is attached to the lower block. What is the force? By experiment, the reading on the balance when raising the weight slowly is 18 lbs., and when lowering it slowly is 12 lbs. What is the force? What is the friction?

3. In a system of pulleys in which four ropes are supporting a weight of 25 lbs., the lower block weighs 7 lbs.; what force would balance this, if there were no friction? By experiment, the readings on the balance are 12 lbs. to raise and 4 lbs. to lower. What is the force? What is the friction?

4. State the Law of Machines.

5. In exercise 2, if the weight of 30 lbs. is raised 1 foot, how far does the force move? How many foot pounds of work are done on the weight? How many foot pounds of work does the force do? Does the law of machines hold?

6. In exercise 3, if the 32 lbs. of weight is raised 1 foot, how far does the force move? How many foot pounds of work are done on the weight? How many foot pounds of work does the force do? Does the law of machines hold?

Lesson XIV

Record the weather conditions.

What were the results of your experiment at home with the pulley?

The Jack-screw.—The jack-screw is used for raising very heavy weights. Probably some of you have seen them used to raise houses or barns when they were being moved, or when new foundations were being put under them. Let us examine a jack-screw to see if we can learn the relation between the weight and the force that would support it, if there were no friction. The friction is a very important factor in the jack-screw, and we will take it up later in the lesson.

In the last lesson we learned the very important law of machines, *i. e.*: "If there is no friction, the work done by a machine is equal to the work put into it." We found also that work is measured in foot pounds. The work done by a machine is the weight \times the distance the weight

is raised, and the work put into it is the force \times distance the force moves. So we might state the Law of Machines as follows: "If there is no friction, the force \times distance the force moves is equal to the weight \times the distance the weight is raised." For example, if the force moves 50 times as far as the weight, then the force is $\frac{1}{50}$ of the weight. Let us apply the law to the jack-screw.

Experiment XIV. — The Jack-screw and the Law of Machines.

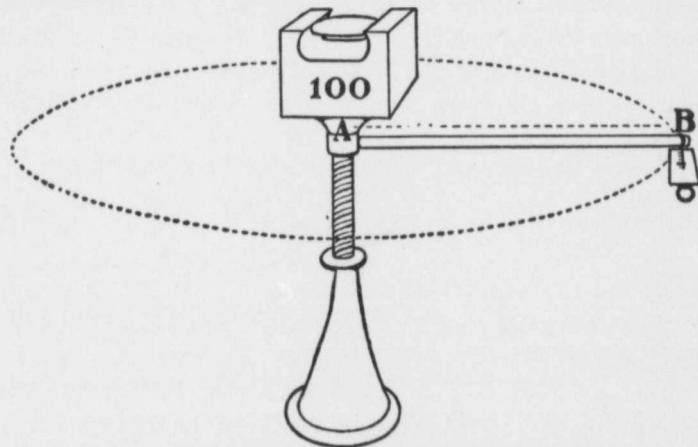

Fig. 16. Apparatus: Jack-screw, Weight, Spring Balance.

1. Notice that when the force at B makes one revolution, the weight is just lifted through the pitch of the screw, *i.e.*, from the top of one thread to the top of the next.

The force moves through the circumference of the circle of which AB is the radius, while the weight is lifted from one thread to the next. Measure AB and calculate the circumference of the circle of which AB is the radius. (Circumference = $2 \times \frac{22}{7} \times AB$.)

Measure the distance from the top of one thread to the top of the next, *i.e.*, the pitch of the screw.

Now use the law of machines given above to calculate the force that would just balance the weight used in (2) below. Force \times circumference of circle of which AB is radius = weight \times pitch of screw.

2. Find this force experimentally.

Weight.—Unscrew the head of the jack-screw, and weigh it and the handle; replace it and have a boy whose weight is known stand on the screw. The total weight is equal to the sum of these two weights. For example, if the head of screw and the handle weigh 20 lbs. and the boy weighs 100 lbs. the total weight is 120 lbs.

Force.—Attach the spring balance at B and pull gently, so that the total weight is slowly raised. Record the reading on the balance.

Now pull in the opposite direction, so that the weight is slowly lowered. Record the reading on the spring balance.

$$\text{Reading I} = \text{Friction} + \text{force.}$$

$$\text{Reading II} = \text{Friction} - \text{force.}$$

Subtract the second from the first and we get :

$$2 \text{ Force} = \text{Reading I} - \text{Reading II.}$$

or
$$\text{Force} = \frac{\text{Reading I} - \text{Reading II}}{2}.$$

Compare this force with the value calculated in (1).

Friction. — You will notice that when we let go the handle of the screw, the weight does not go down. This is because the friction is holding it, and therefore the friction must be greater than the force that would balance the weight, if there were no friction. This is true of the jack-screw, no matter how great the weight is, because the friction increases with the weight.

Let us find the friction and compare it with the force.

Take the readings given in (2) above and add them together.

Reading I = Friction + force.

Reading II = Friction - force.

adding them, $2 \text{ Friction} = \text{Reading I} + \text{Reading II}$.

$$\text{Friction} = \frac{\text{Reading I} + \text{Reading II}}{2}.$$

Is the friction greater than the force that would balance the weight if there were no friction?

Suggestions for experiments at home :

Make experiments similar to 1 and 2 with a jack-screw, if you have one. If not, you can make experiments with an ordinary bolt and nut as follows : Clamp nut in vise or other support. Screw in bolt part way with head above nut. Attach a weight to the bolt below the nut with a wire. Attach wrench to head as handle. Measure length of handle, pitch of screw and weight. Calculate the force, then find it experimentally.

Similar experiments may also be made with a revolving piano stool.

Exercises

1. The handle of a jack-screw is 21 in. long, the pitch is $\frac{1}{2}$ in., the head weighs 28 lbs., and a weight of 500 lbs. is on the head. What force would just balance the weight, if there were no friction?

Ans.

Force \times distance force travels = weight \times distance weight is raised.

$$\text{Force} \times 2 \times \frac{2}{7} \times 21 = 528 \times \frac{1}{2} \text{ or Force} = 2 \text{ lbs.}$$

2. The handle of a jack-screw is 14 in. long and the pitch is $\frac{1}{2}$ in., the head weighs 28 lbs., and the weight on it is 500 lbs. What is the force that would support the weight, if there were no friction?

3. In finding the force experimentally, we find that the reading when raising the weight is 13 lbs., and when lowering it is 7 lbs. What is the force and what is the friction?

4. The handle of a jack-screw is 28 in., the pitch is $\frac{1}{4}$ in., the weight of head is 20 lbs., and the weight is 3,500 lbs. What is the force that would balance this weight, if there were no friction?

5. If the reading on the balance when the weight is slowly lifted is 25 lbs., and when the weight is slowly lowered is 15 lbs., what is the force? What is the friction?

Lesson XV

Record the weather conditions.

What were the results of your experiments at home with the jack-screw?

Going up Hill.—We all know that it is harder to pull a weight up hill than to pull it on the level. Let us answer the question. "How much harder is it?" This is somewhat hard to answer experimentally without the proper apparatus, so we will state the law first and then test it by experiment. If the road rises 1 foot in 10, then the increased force is $\frac{1}{10}$ of the weight. If the grade is 1 ft. in 20 ft., then the increased force is $\frac{1}{20}$ of the weight, etc. So that if a team of horses is drawing a load of 1 ton (2,000 lbs.), including the wagon, then it would take a pull of $\frac{1}{10} \times 2,000$, or 200 lbs. more to pull the wagon up a grade of 1 foot in 10 ft. than on the level. Similarly, if the grade is 1 foot in 20 ft., the pull would be $\frac{1}{20} \times 2,000$, or 100 lbs. more on the grade than on the level.

The Law is :

$$\text{Increase of Pull} = \frac{\text{Rise}}{\text{Length of Incline}} \times \text{Weight.}$$

Let us test this law by experiment. We will use a small board with a weight on it to represent the wagon and its load, and a larger board to represent the road.

Experiment XV.—Going up Hill, or the Law of the Inclined Plane.

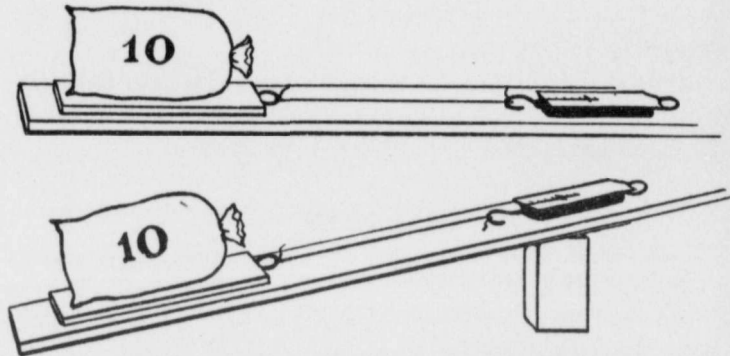

Fig. 17. Apparatus: Boards, Weight, Spring Balance.

The apparatus used in this experiment is usually called an inclined plane, and the law stated above, the Law of the Inclined Plane.

The apparatus consists of a board of planed wood about 5 ft. long and 8 or 10 in. wide, and a smaller board 1 foot long by 6 in. wide.

1. Weigh the small board ; place 10 lbs. on it, and find the force necessary to move it slowly along the large board when it is horizontal. You will notice that it takes a greater force to start the motion than to keep it going. Make your reading while the board is in motion.

2. Raise one end of the long board so that the lower side of the upper end is 6 in. above the table. This is a grade of $\frac{1}{2}$ foot in 5 ft., or 1 foot in 10 ft. So we would expect the increased pull to be $\frac{1}{10}$ of the total weight. Try it experimentally. Is the increase of pull $\frac{1}{10}$ of the total weight? Does the law of the inclined plane hold?

3. Raise one end 1 foot. Calculate the increased pull. Find it by experiment. Does the law of the inclined plane hold?

Suggestions for experiment at home :

1. Make experiments similar to 1, 2 and 3.
2. If you have a small express wagon use it in experiments similar to 1, 2 and 3.

Exercises

1. State the law of the inclined plane.
2. If it takes 2 lbs. of force to drag a 10 lb. weight along a smooth pine board, how much would it take if the board were inclined 1 foot in 10 ft. ?
3. A wagon and its load weigh 1 ton. If it takes 50 lbs. pull to move it on a level road, what is the total pull on a road which has a grade of 5% ; *i.e.*, rises 5 ft. in 100 ft. ?
4. A barrel of oil weighs 240 lbs. It is being rolled up a plank into a wagon. The plank is 12 ft. long, and the bottom of the wagon is 3 ft. above the ground ; what force is necessary ?
5. If the wagon and load mentioned in exercise 3 go down a grade of 2%, how much would the horses need to pull ? If the grade were 4%, would they pull or hold back, and how much ?

Lesson XVI

Record the weather conditions.

What were the results of your experiments with a wagon going up hill ?

In the last lesson we found that it was harder to pull a weight up hill than on the level, and that if, for example, the hill rose 1 foot in going along the incline 10 ft., that then the increased pull was $\frac{1}{10}$ of the total weight. If the hill rose 2 ft. in 25 ft., then the increased pull would be $\frac{2}{25}$ of the total weight, etc.

Let us look at this going up hill, or the inclined plane, from the standpoint of the law of machines. Let us suppose that a wagon and its load weighed 1 ton (2,000 lbs.),

and that it is being pulled up a hill that rises 1 foot in 10 ft. Then the pull will be ($\frac{1}{10} \times 2,000$) 200 lbs. more on the grade than on the level. If the wagon is drawn 50 ft. up the incline its weight has been lifted 5 ft. above the level. Does the law of machines apply? The law is, "If there is no friction, the force \times the distance the force moves equals the weight \times the distance the weight is lifted." We find that the law applies in this case because

$$200 \times 50 = 2,000 \times 5.$$

We find, in fact, that the law of machines applies to all machines. Let us take one or two practical examples. If you were trying to decide which of two root cutters to buy, and wished to find the force with which the knives would cut if 20 lbs. of force were applied at the handle, you would proceed as follows: Move the handle 12 in. and measure how far the knife moved. Suppose the knife moved just 4 in., the law of machines in this case would be:

$$\begin{aligned} \text{Force} \times \text{distance force moves} \\ &= \text{cutting force} \times \text{distance the knife moves,} \\ \text{or } 20 \text{ lbs.} \times 12 \text{ in.} &= \text{cutting force} \times 4 \\ \text{or cutting force} &= 60 \text{ lbs.} \end{aligned}$$

If there were six rows of knives on the cutting cylinder and it were possible for two rows to be cutting at the same instant, the cutting force for each row would be 30 lbs.

The same method may be applied to find the cutting force on a mower. Measure the total distance the sickle moves back and forth when the mower moves ahead 1 foot. Let us suppose the sickle moves a total distance of 3 ft. while the mower is moving ahead 1 foot, then the cutting force is $\frac{1}{3}$ of the extra force the horse exerts when the sickle is in gear. If this extra force is 60 lbs., then the sickle exerts a cutting force of 20 lbs.; if there are 20

knives on the sickle, then each knife has an average cutting force of 1 lb. Of course as there is always friction, the actual cutting force will be somewhat less than 1 lb.

Lesson XVII

Record the weather conditions.

Wheels.—What is the advantage of having wheels on a wagon? We have all drawn weights on these small express wagons that girls and boys play with, and we know that it is easier to draw the weight when it is on the wagon than if we tried to drag it along the ground. Why is it easier? We know that it is because of the wheels; but how do wheels make it easier? Let us proceed to answer this question, but first let us settle why it is hard to drag a weight along the ground or pavement or side-walk. You will answer that it is because of the friction between the weight and the other surfaces. Friction is due to small projections in the two surfaces in contact; these projections strike against each other and retard the motion. If the weight and pavement were absolutely smooth it would take no force at all to keep the weight moving on the pavement, if it were once started, and if the pavement were perfectly level. How then does the wheel overcome the friction of the road? If you will examine Fig. 18 you will see that the wheel overcomes the friction of the road by lifting the weight over the projections.

The wheel is really a lever. The obstruction at A is the fulcrum. The force is applied along OF, and the force arm is the perpendicular distance AB from the fulcrum A to the line along which the force acts. The weight is at the axle O and acts along the line OD, therefore the weight arm is AC, the perpendicular distance from the

fulcrum to the line along which the weight acts. We see that the force arm is much greater than the weight arm, therefore the force is much less than the weight. Wheels then make it easy to draw a weight, because each wheel acts as a lever to lift the weight over obstructions.

Friction at Axle.—There is, of course, some friction at the axles, but this is small, because (a) the bearings are smooth and fitted to one another, and (b) they are oiled.

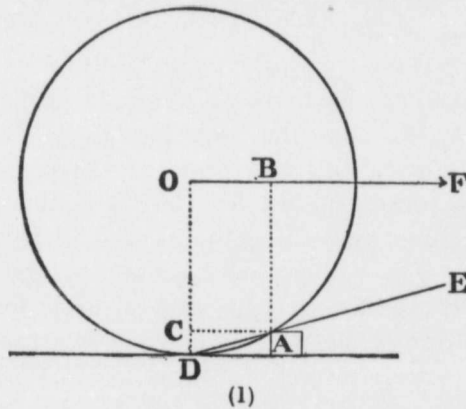

Fig. 18.

The oil clings to both surfaces, filling up the small hollows and covering the small projections, so that the motion really takes place between two surfaces of oil. It has been found by experiment that the friction at the axles of an ordinary wagon amounts to about 20 lbs. per ton of load, or only 5 lbs. per axle for the quarter of a ton on each axle.

Size of Wheels.—Is it better to use large wheels or small wheels on a wagon? We can answer this question by examining (1) Fig. 18, and (2) Fig. 18 a. Wheel (1) is twice the size of wheel (2), and the obstruction at A is of the same size in each case. Examine the weight arm AC

and force arm AB in each wheel. What do we find? We find that the weight arm is longer in (1) than in (2), but also that the force arm is much longer in proportion in (1) than in (2), and remains so, no matter how large the obstruction is. The ratio of the force arm to weight arm is greater then in wheel (1) than in wheel (2); therefore, the force required to pull a wagon with wheels of the size of (1) is less than if the wheels were of size (2); therefore, it is better to use large wheels on a wagon.

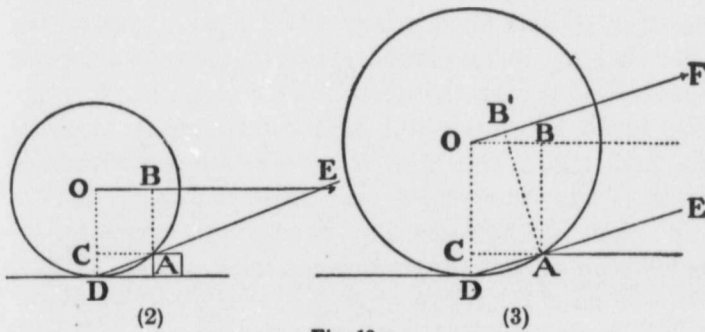

Fig. 18 a.

Let us look at the question from a different point of view. If a wagon is being drawn over a field or a soft road bed, will a wagon with large wheels sink as deep as a wagon with the same load, but with smaller wheels? We can answer this at once if we think of an exaggerated case. Suppose, for instance, that the wheels were as small as bed castors; we know that the wheels would sink deeper than large wheels. And the same reasoning holds if the wheels are not so small as this. The large wheel does not sink so far as a smaller wheel, because the curve of the tire is less sharp in the large wheel than in the small wheel, and it does not sink so far in order to get the same area of base to support the load.

What effect does this have on the force necessary to pull the load along? We know that it is harder to pull a load when the wheels sink into the road bed. But why is it? We can answer this by again looking at (1) and (2) Figs. 18 and 18 a. When the wheels sink into the road the load is really being pulled up-hill all the time. If we think of the wheels sinking to the depth represented by obstruction A in (1) and (2), the line DE in each case represents the real road bed and we see that the grade is steeper in (2) than in (1); therefore the pull would be greater for the small wheel than for the large wheel if they sank to the same depth. But we found above that the small wheel would sink deeper than the large wheel, therefore the pull would be greater still for the small wheel than for the large one. This then is a second reason why it is better to use large wheels than small wheels.

What then determines the size of wagon wheels? Let us leave the answer to this question until we have studied the position of the traces.

The Traces.—Should the traces slant downward from the hames to the whiffletree? It is the common practice to have them do so. Is this practice correct?

Let us consider the question first in connection with the wheel. If the road is perfectly rigid; that is, the wheels do not sink in at all, then there is no advantage in slanting the traces, as far as the wheel is concerned, because we wish to pull the load forward, and any upward lift is wasted.

On ordinary roads, however, where the wheels sink in to a certain extent, the wagon is really going up-hill all the time, and it has been found by experiment that the pull is least when the traces are parallel to the grade up which the wagon is going. See (3) Fig. 18 a. DE is the grade and OF the slant of the trace. We can see why the

slanting trace OF is better than if it were horizontal along OB; in the latter case part of the force would be exerted to drive the wheel against the grade, while with the trace OF all the pull is exerted along the grade.

Now let us consider the question of the traces in connection with the horse (see Fig. 19).

The horse makes use of its weight in pulling a load. Consider that the centre of gravity of the horse is at B; *i.e.*, B is the point

at which all the weight of the horse may be considered to act. The hoof at A is the fulcrum; the weight of the horse acts along the line BC, and the weight arm is AC. If the trace is horizontal the pull is along

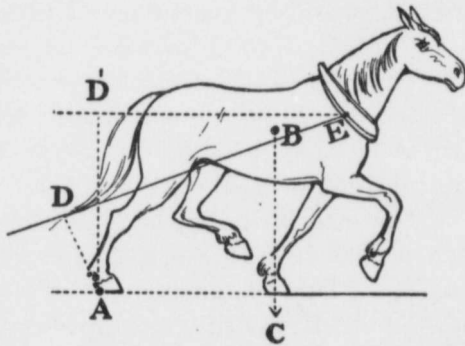

Fig. 19.

the trace ED' and the pulling arm is AD'. Notice that if the trace is slanting as in ED the pulling arm is AD, and is shorter than AD'. If we are considering the effect of the weight of the horse on the pull, the shorter AD is the greater will be the pull, because according to the lever law: weight of horse \times AC = pull \times AD, as AD decreases the pull increases.

When one of the forefeet of the horse is on the ground as at C, Fig. 19, only part of the weight of the horse is used in pulling. You have probably noticed, however, that when a horse is exerting its greatest pull it lifts both forefeet off the ground and throws its head and body forward, so as to give the greatest effect to its weight.

We have found then two reasons why the traces should be slanted. First, because the wheels sink into the road and the pull on the trace is most effective when it is exerted in a direction parallel to the grade up which the wagon is really going. Second, because the horse uses its weight in pulling, and the sharper the slant of the trace the more effective its weight becomes.

Let us now study the question, What factors determine the size of wagon wheels?

We have already noted some of these factors, namely :

1. Two reasons why the wheels should be large.
2. Two reasons why the traces should slant downwards from the hames, which would tend to make the wheels small.

In addition to these there is :

3. The ease in loading and the stability of the wagon when loaded, both of which are secured by small wheels.
4. The height of the horse, which limits the height of the wheels. If we had horses twice as tall we could make the wheels twice the usual size.

Each of these factors has an influence on the size of the wheels, and in some cases one factor is more important than the others, as will be seen in the following :

In the ordinary wagon which is used for all purposes, the size of the front wheels is determined as follows: When the average height of the horses used is known, and the best slant of the traces for the ordinary condition of the road, then the axle of the front wheel may be as high as the lower end of the traces. A study of the force arm and weight arm in Figs. 18 and 18a shows us that there is no advantage in having the axle higher than this.

The back wheels in all wagons may be higher than the front wheels, because they are pulled by the reach which

is horizontal and higher than the front axle. And the axle of the back wheels may be as high as the line of draft along the reach.

In the stage coach and prairie schooner which are drawn by a number of teams of horses, the traces of the forward teams are horizontal, so that the slant of the traces is unimportant, and the front wheels may be as high as the point on the hames to which the traces are attached. Against this, however, is the stability of the load, which is less as the wheels are higher. This may be secured, however, by making the axle longer, so that the wheels are farther apart.

In trucks used for short hauls with heavy loads the ease in loading is the important factor, and as a result the wheels are small.

Conclusion

TO THE BOYS AND GIRLS.—Now we have finished our study of some of the common tools, and we have found that they all obey some simple law, the most important of which are the Lever Law and the Law of Machines. You will notice that in all our work we started with our common knowledge of the tools; then, first, we made it more exact by measuring everything that had any bearing on the use of the tool; then, second, we tried to discover some law connecting the quantities measured; and third, when we had found the law we applied it to other tools, to see whether it would help us understand their use.

When we know the law which a tool obeys, we are the masters and the tool is our servant. We can calculate beforehand exactly what service the tool will give us, and what changes in it are necessary to adapt

it to other needs. This is the way that man has progressed in his conquest of nature, and has adapted the forces of nature to his own use. In general, the way in which this progress has been made is as follows: For long years, generally centuries, man has gradually learned by observation and experience more and more of some force of nature. This constitutes what we have called our common knowledge of the force; then some man appeared, wiser or more fortunate than the others, who by measurement and reasoning discovered the law which this force obeys. When the law was discovered man became the master, because then he was in a position to make this force of nature serve him.

Had we the time and space we might take up the study of many more tools. For example, pumps, wind-mills, water wheels, the hydraulic jack, the hydraulic ram, etc. After finishing tools, the next step would be to study the climate and the soil. This would lead to a study of the general physical properties of solids, liquids and gases, also to a study of heat, light and electricity. Under heat we would study the nature of heat and its relation to climate and soil, also systems of heating and heat engines, such as the steam engine and the gas engine. Under light we would study the nature of light; its effect on plant growth, also color, mirrors, lenses, the opera glass, telescope, stereoscope, camera, etc. Under electricity we would study lightning and lightning rods, also batteries, dynamos, motors, electric bells, electric lights, electric-plating, the telegraph, the telephone and the wireless telegraph.

For those of you who wish to continue this study it would be well to get a good text-book on physics, and the author of this chapter will be glad to recommend such a text-book to those who write to him.

Within the last hundred years mankind has made marvellous progress in the discovery of the laws which govern the forces of nature, and in the use of these forces. There is no doubt that great progress will be made in this direction in the next hundred years. The men and women who will be leading in this progress twenty years hence are now boys and girls in school, just like the boys and girls who are reading these pages, and it is quite possible that some of these readers may be leaders in the future. Some may discover new laws of nature, and all may do a great service by gaining a knowledge of the laws already known, and the way in which they affect their own lives and the lives of their neighbors, and by spreading this knowledge among their neighbors.

ANSWERS

Lesson I

- | | | |
|-------------------|-------------------|------------|
| 2. 16 in. ; 4 in. | 3. 12 in. ; 6 in. | 4. 10 lbs. |
| 5. 4 ft. | 6. 25 lbs. | |

Lesson II

- | | | |
|-----------|---------------|-----------|
| 1. 4 lbs. | 2. 2,250 lbs. | 3. 4 lbs. |
| 4. 2 lbs. | | |

Lesson III

- | | | |
|------------|---|-----------|
| 1. 6 lbs. | 2. 19 lbs. | 3. 6 lbs. |
| 4. 25 lbs. | 5. Yes, because one hand must exert much more force than the other. | |

Lesson IV

- | | | |
|------------------------|------------------------|------------------------|
| 1. $4\frac{1}{4}$ lbs. | 2. $6\frac{1}{4}$ lbs. | 3. $8\frac{1}{4}$ lbs. |
| 4. 26 lbs. | 5. 36 lbs. | |

Lesson V

To weigh a 200 lb. man.—Arrange the crowbar with the point on a strong support, and spring balance at say 60 in. from the point. Attach a swinging seat at 3 in. from the point. Find the force necessary to support the seat and bar, then let the man sit on the seat and his weight is 20 times the extra force indicated on the balance, because the force arm is 20 times as long as the weight arm.

- | | | |
|----------------|------------|----------------------------|
| 1. 16 lbs. | 2. 26 lbs. | 3. 1,500 lbs. ; 6,000 lbs. |
| 4. 10,800 lbs. | | |

Lesson VI

- | | | |
|---|------------|---------------|
| 1. 10 lbs. | 2. 14 lbs. | 3. 11.56 lbs. |
| 4. Less force required to support the weight. | | |

Lesson VII

- | | | |
|-------------------------------|------------------|--------------------|
| 1. 3 lbs. 6 ozs. | 2. 5 lbs. 6 ozs. | 3. 4 lbs. 5 ozs. ; |
| 5 lbs. 5 ozs. ; 6 lbs. 5 ozs. | 4. 2 lbs. | 5. 1 lb. |

Lesson VIII

- | | | |
|-------------------------|------------------------|---------|
| 1. $10\frac{2}{3}$ lbs. | 2. $1\frac{2}{3}$ lbs. | 3. Yes. |
| 4. 20 lbs. | 5. 4 lbs. | 6. Yes. |

Lesson IX

- | | | |
|-------------------------|------------------------|---------|
| 1. $11\frac{1}{3}$ lbs. | 2. $3\frac{1}{3}$ lbs. | 3. Yes. |
| 4. $1\frac{1}{3}$ lbs. | 5. $9\frac{1}{3}$ lbs. | 6. Yes. |

THE PHYSICS OF SOME COMMON TOOLS 243

Lesson X

1. 10 in.
2. 14 in.
3. 4 lbs.
4. First boy, 33 lbs., Second boy, 23 lbs.

Lesson XI

2. 15 lbs.
3. $1,333\frac{1}{3}$ lbs.
4. 8 lbs.
5. $888\frac{2}{3}$ lbs.

Lesson XII

1. $4\frac{1}{6}$ lbs.
2. 180 lbs.
3. $12\frac{1}{2}$ lbs. ; $2\frac{1}{2}$ lbs.
4. $6\frac{1}{2}$ lbs. ; $1\frac{1}{2}$ lbs.

Lesson XIII

2. 15 lbs. ; 15 lbs. ; 3 lbs.
3. 8 lbs. ; 8 lbs. ; 4 lbs.
5. 2 ft. ; 30 foot pounds ; 30 foot pounds ; yes.
6. 4 ft. ; 32 foot pounds ; 32 foot pounds ; yes.

Lesson XIV

2. 3 lbs.
3. Friction, 10 lbs., force, 3 lbs.
4. 5 lbs.
5. Friction, 20 lbs., force, 5 lbs.

Lesson XV

2. 3 lbs.
3. 150 lbs.
4. A little over 60 lbs.
5. 10 lbs. ; hold back 30 lbs.





A WELL-KEPT ORCHARD.

F

oc
be
cu
sto
the
eve
mo
ho
r
the
pec
qua
ten
A
for
tim
flou
me
sho
ski
few
in
eas

FRUIT-GROWING IN NEW BRUNSWICK

BY

W. W. HUBBARD, SECRETARY FOR AGRICULTURE

EARLIEST history relates that fruit-growing was the first occupation of man. Ages before the beasts of the field became subject to human control, or the complex agricultural operations of the live stock industry were understood, primeval man gained his living from the fruits of the earth. Our ancestors began their life in a garden, and ever since the garden and the orchard have been the most pleasant and most healthful environment for the home—the best cradle of the human race.

The people of New Brunswick are fortunate in that the climate and most of the soils of the Province are peculiarly adapted to the successful growth of the highest quality of those fruits and vegetables which belong to the temperate zone.

Although the Province has been settled by Europeans for more than two hundred years, and during all that time apples and small fruits have to some extent been flourishing, fruit-growing as an occupation is yet in its merest infancy. Enough, however, has been done to show what we may reasonably expect in the future when skill and intelligence are employed. Except in a very few localities, apple trees grow and bear fruit everywhere in the Province when given proper attention. Pears are easily grown in some sections, and it is probable ere long

that peaches and quinces adapted to our climate will be propagated and grown in our more sheltered districts. Plums of many kinds, and nearly all the bush fruits and berries, grow everywhere when the attempt is intelligently made, while here and there productive grape vines flourish.

APPLE GROWING

The districts where the greatest success in apple growing has thus far been obtained are: The St. John Valley in Kings, Queens and Sunbury counties and in the Petitcodiac Valley, for nearly all varieties. In York, Carleton, parts of Westmorland, Albert and Kings Counties, for the early winter varieties, while fall varieties grow practically everywhere they are planted and receive attention.

VARIETIES

It is not possible to state definitely what varieties are best for the conditions of the several localities, for each year is demonstrating the value of new kinds; and it may be in twenty years from now that our list of apple trees most profitable to plant will be largely changed. The following varieties are among those grown with success in New Brunswick:

Early Fall Varieties.—Crimson Beauty, Duchess of Oldenburgh, Sharpe's New Brunswick, Yellow Transparent, Red Astrachan, Irish Peach, St. Lawrence.

Late Fall and Early Winter Varieties.—McIntosh Red, Fameuse, Wealthy, Alexander, Wolfe River, Dudley's Winter or North Star, Milwaukee, Princess Louise.

Winter Varieties.—Talman Sweet, Bishop's Pippin, Golden Russet, Rhode Island Greening, Baldwin, Ribston Pippin, Blenheim, Northern Spy, King of Tompkins.

There are also some very promising seedlings, native to the Province, that are giving good results. Speaking generally, all the winter varieties give best and quickest returns when top grafted upon hardy stocks. The Talman Sweet, however, is a thrifty grower, very hardy and prolific, with tough wood, and makes one of the best trees upon which to graft other varieties; the fruit will keep through till April.

The success which some orchardists have obtained might have been more widespread had more attention been given to the requirements of the trees, and to that protection from insect pests and fungous diseases which both trees and fruit need.

For a great many years the sales of young apple trees to intending orchardists have been large, and yet our bearing orchards and our apple crops have not increased in proportion to the trees planted. Tens of thousands of dollars have been invested in apple trees that have perished in their infancy.

In nearly every school district, even the youngest scholar can point to dead and dying trees, and will quite likely have the idea that apple growing is not a sure business and may think that the locality is not adapted to fruit raising; yet he or she will generally be able to observe some trees that flourish and bear fruit.

CAUSES OF FAILURE

There are many reasons why apple and other fruit trees die young:

1. Because of inferior and unthrifty trees sent from the nursery. Unscrupulous agents sometimes take advantage of buyers unacquainted with apple growing to unload upon them refuse stock.

2. Because the trees are of varieties not adapted to our climate and conditions.

3. Because the trees are set upon wet land or land not properly prepared for them.

4. Because the trees are not properly planted. Great care should always be taken to see that the roots are spread out in a natural position and fertile surface soil firmly pressed about them.

5. Because of neglect to cut off injured roots and to prune back the top to correspond with the shortened root system.

6. Sometimes because the trees are set on southern slopes where the snow goes off; the ground thaws early and the sap starts before freezing nights are past; and sometimes from lack of shelter from prevailing winds when placed in an exposed position.

7. Because no mulch is placed round the tree, or the surface soil about the young tree is not frequently stirred. A compact surface soil allows excessive evaporation of soil moisture, and in a dry season the tree may perish for lack of water.

8. Because grass or grain crops are allowed to grow close up to the tree and rob it of moisture and nourishment.

9. Because cattle or other stock are allowed to eat the leaves and branches of the trees.

10. Because mice are allowed to girdle the trees below the snow.

11. Because the trees are allowed to fruit too heavily while young.

12. Because the bark and limbs of the tree are torn and broken off by the whiffletrees and harness of the team used in cultivating among them.

13. Because bark lice, borers or other pests are allowed to destroy the tree.

These and perhaps other conditions, all of them preventable, have caused the death of fruit trees innumerable, resulting in great waste of money and frequently discouraging not only individuals but whole communities from trying to grow tree fruits.

ESSENTIALS TO SUCCESS

While the methods advised apply primarily to apple trees, the general principles involved are applicable to almost all other fruit trees.

There are three kinds of orchards :

1. The small orchard of less than fifty trees, designed to simply supply the home with fruit.
2. The orchard as one department of the farm, and merely an adjunct to other and more extensive operations.
3. The orchard as a commercial enterprise, and intended to be the main business of the farm.

THE SITE OF THE ORCHARD

When but a few trees are to be planted for home use, it is nearly always preferable to have them near the house, but for larger operations it is well to choose carefully the location for the proposed orchard before the trees are ordered.

The first essential to success in fruit growing is a well-drained soil. If the desired site is not naturally dry it must be underdrained so that the water level shall not be within at least three feet of the surface. It is not necessary that an orchard should be upon a slope, but when rolling or hilly land is used, in New Brunswick it may be stated as a general rule that a slope to the north is better than a southerly incline—first, because it does not expose the trees to early thawing in the spring nor to sunscald of their trunks ; and second, because this slope is usually

more free from late spring and early fall frosts. In many parts of the province a westerly slope is to be preferred to an easterly one, as sometimes cold, blighting easterly winds occur while the trees are in blossom. Fruit trees should never be planted in hollows where the water will form ponds after the ground is frozen and then freeze solid about their trunks.

WINDBREAKS

If the orchard is not naturally protected from the wind by trees or by rising ground, a windbreak may be planted with good effect along the north and west sides, or any other side from which the greatest injury comes, the object being not to stop the wind altogether, but simply to check its velocity, as if a windbreak is high and very dense it stops the circulation of air in the orchard to a large extent, and this gives very favorable conditions for the spread of both insect pests and plant diseases. On the other hand, a proper windbreak lessens the force of the wind and thus protects the trees, which will grow straighter and shapelier; it will also very materially lessen the amount of windfalls, and it will permit of growing varieties which will not succeed under ordinary exposure. Wind is one of the most important factors in drying out the land and causing drought. If its force is checked the evaporation of moisture from the soil will not be so great.

One of the best trees to plant for a windbreak is the Norway Spruce (*Picea excelsa*). It is a rapid growing evergreen and is hardy almost everywhere that apples can be grown successfully. A single row of these trees planted from eight to ten feet apart is quite sufficient. Other varieties of spruce, cedars and Norway pine are all good. In a very bleak location a double row eight feet apart may be desirable.

THE SOIL

Apple trees grow well in almost any kind of soil if it is thoroughly drained. It is this adaptability of the apple which causes the trees to be planted frequently on poor land ; but the better the soil, the better the results will be. A good orchard soil should, in the first place, be abundantly supplied with plant food in a form that may be made easily available. It should be rich in humus and should be easily worked, and it is perhaps best upon limestone formation. Sandy soil is easily worked, but is, as a rule, not rich in available plant food and is also lacking in humus. Plant food also which is applied in the form of barnyard manure and artificial fertilizers is easily leached away in sandy soil. In the colder parts of the country root-killing is more prevalent in sandy soils. Clay land, on the other hand, is too stiff and is hard to work, the soil baking easily, and making it difficult to cultivate. Where, however, the ground is not kept cultivated and the fertility maintained by top dressing, trees are grown very successfully and good crops produced on this kind of land. The trees make less growth and on this account develop more fruit buds than on light soils. Sandy loam and clay loam soils are, as a rule, the most suitable, and probably clay loam soils are the best for apple growing in the best apple growing districts. Sandy loam soils are better further north, as they are warmer. Land which has been exhausted of much of its plant food by growing cereals or other crops upon it is less suitable for orchard purposes.

PREPARATION OF THE LAND

It very often happens that the farmer or fruit grower suddenly decides to plant an orchard. No previous

thought perhaps had been given to the matter, or if there had, nothing was done to get the land into condition for the young trees. The trees are bought, the land hastily, and not very well prepared, and the trees set out to take their chances. No after cultivation will fully make up for neglect of the thorough preparation of the land. Trees should begin to grow thriftily from the time they are planted, if they are to obtain a good size before they begin to bear heavily, and if the land is not thoroughly prepared and in good condition when they are planted, growth is likely to be slow. It is much better, if one has no land in good condition, to delay planting a year, and give the soil the necessary attention. The time will not be lost, as the trees will do much better. Land which has been well manured for root crops, ploughed in the autumn, and again ploughed in the spring and thoroughly levelled and pulverized with the harrow, would be in a good condition for planting the trees. If the subsoil is near the surface, the subsoil plough should be used after the ordinary one, loosening the soil from four to six inches deeper than the former.

Sod land ploughed in the autumn, top dressed in the spring with a good coating of barnyard manure and then ploughed again and thoroughly pulverized with the harrow, should also bring the soil into good condition. A green crop, such as clover ploughed under in the spring and the land thoroughly harrowed, would also be a very good method.

LAYING OUT THE ORCHARD

The distance apart that apple trees should be planted will vary according to the varieties used, the locality, the land at the planter's disposal, and the other purposes, if any, for which he intends to use the land. In order to

thrive best and produce fruit of good size and color, the trees should have abundance of sun, light and air, and they cannot obtain these if planted too closely together. Spraying has become such an integral part of successful fruit growing that sufficient space must be left between the trees to permit of doing this work thoroughly. With close planting, injurious insects and fungous diseases are more prevalent than where there is abundance of light and air. The one important advantage of close planting is the protection the trees afford each other, but it is only in the very coldest parts of the country where this protection is necessary, especially if low-headed trees are planted. The great mistake in the past has been that trees have been planted too closely, the result being the production of poorly colored, ill-shaped and scabby fruit.

In New Brunswick the general rule may well be, never to plant at less than thirty feet in each direction unless the grower has definite plans for thinning as the trees grow. Where it is desired to utilize the land as fully as possible with trees, a very good plan is to set the trees twenty feet apart one way and thirty the other, setting, in every other row of those twenty feet apart, early-bearing and early-maturing trees which can later be removed, leaving the balance of the trees thirty by forty feet apart. Dwarf pears, plums, cherries, etc., may be set in these closer rows if desired. Trees may also be set diagonally, though where it is desired to grow other crops while the trees are young, this is not an economical system.

Cultivation is made more easy and in every way the orchard is better and more sightly if the rows of trees are straight. The site should therefore be carefully surveyed and marked out before the planting is begun. A stake should be set at every point where a tree is to be planted.

The measuring can be most expeditiously done by using a long heavy wire, marked at the proper distances for the rows of trees. Two men will stretch the wire and a third person stick a stake at each mark.

PLANTING THE TREES

Trees may be planted in the autumn, but spring planting is usually the more successful, providing the trees are set out before growth begins. When the nurseryman cannot deliver trees before the 10th of May, they should be delivered the fall previous, and be kept through the winter by heeling them in where the water will not accumulate, where there will not be danger from mice, and where the trees will be covered by snow. A trench should be made deep enough to allow the roots of the trees to be well covered ; they should be placed in it in a single layer and in slanting position, so that the tops will only be about a foot from the ground.

As soon as the land is in good condition in the spring, plant the trees. Holes should be dug before the trees are uncovered and must be large enough to accommodate the roots spread to their full extent. They should be made about eighteen inches deep ; the subsoil should then be loosened a few inches deeper but not removed. Sufficient surface soil should now be thrown back into the hole to set the tree about an inch deeper than it was in the nursery. This soil should be rounded up and compacted in the centre, thus enabling the spreading of the roots in a natural position. Roots of apple trees have not many fibres, and it is necessary to spread carefully what are left on the tree, to get best results. Broken or bruised roots should be cut off before planting the trees. Manure should never be placed in contact with the roots.

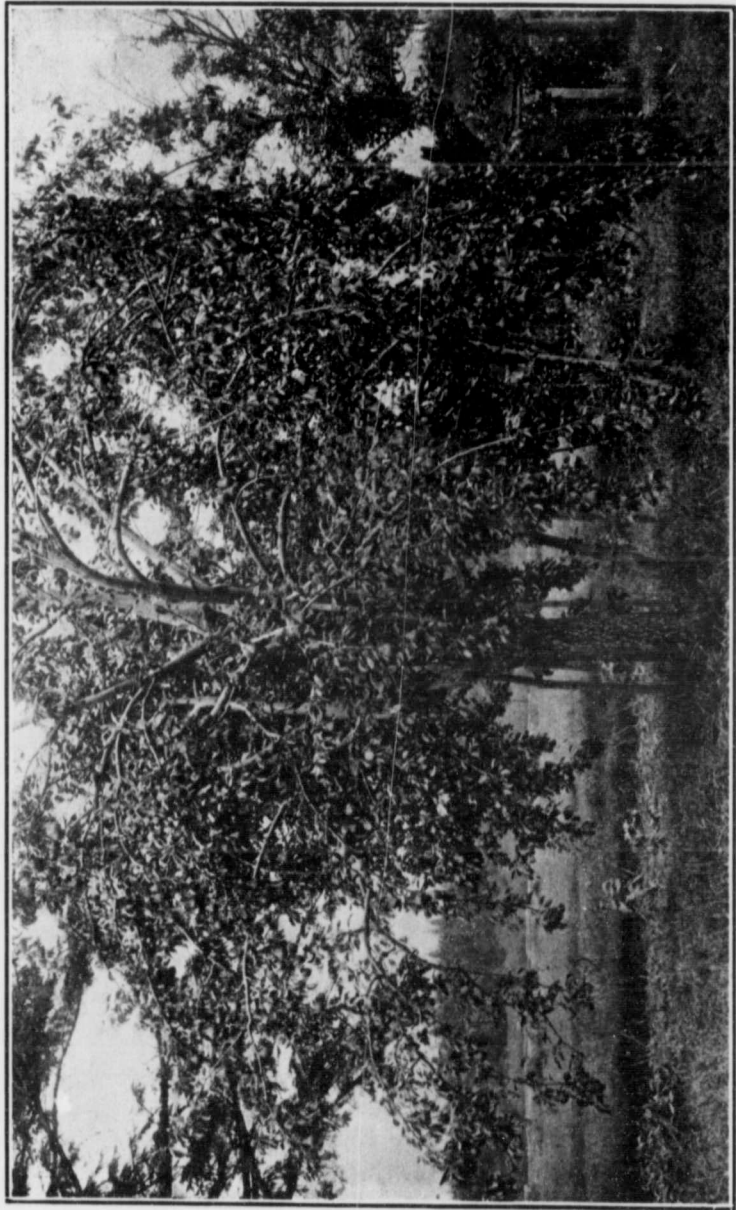

A PEAR TREE NEAR FREDERICTON.

The work of planting can be most expeditiously performed by using a "planting board." This is simply a board one inch thick and five or six feet long, with a notch cut from one side to the centre at equal distances from each end, and then a two-inch hole bored a few inches from each end. Before commencing to make the hole, the digger places the board on the ground with the notch pressed against the stake (where the tree is to go); he then puts a peg through the hole at each end of the board. The board is removed and the hole dug, and when the planter comes along with the tree, he places the board over the pegs again, and by placing the tree in the notch has it in the exact position from which the stake was removed. Absolutely straight rows can be had by this method without the delay and trouble of sighting.

The roots of the trees should not be allowed to become dry from the time they are dug in the nursery, or received from the nurseryman, until they are planted. Much of the failure in planting comes through carelessness in this regard. When taking the trees to the orchard it is a wise precaution, especially if there are drying winds blowing, to puddle the roots in a thin mixture of loam and water, which will prevent, in a large measure, the small fibres from drying out. In addition to this, the roots should be protected until the trees are planted, by covering them with wet sacking or straw. Too much precaution cannot be taken in this matter.

The tree being now placed upright in the hole and the roots carefully spread out, the surface soil is gently thrown in and worked in among them, by the hand, if necessary. It is very important to have the soil come in close contact with the root fibres, in order that the best conditions may be afforded the tree to begin growth promptly. When the roots are well covered, more good soil should be

thrown in, and when the hole is about half full it should be well tramped with the feet, after which the hole should be filled level with the surface of the soil, tramping being done while it is being filled. The surface of the soil should be left loose, as this will help to prevent evaporation of moisture from the soil which has been thrown in. It is not necessary to water any tree if planting is done at the proper season and the soil fairly moist and well compacted about the roots.

If the orchard is in an exposed position and the trees large and with high trunks, it will pay to tie them to stakes to keep them from getting loose.

In districts where drought is liable to occur, or even in places where the soil is likely to become rather dry, it will be wise to mulch the trees to a depth of from four to six inches with manure, straw, sawdust, or anything of that nature which will not become a compact mass. If this is placed about the base of the tree and left during the summer it will keep the surface soil loose and prevent evaporation of moisture, and the growth of the tree will be much more rapid. A good mulch may be the means of preventing a tree from dying if the season is very unfavorable or the tree in poor condition. If the mulch is loose when winter sets in there may be danger from mice, and this should be guarded against. If mulch is not used, the surface soil should be kept stirred during the summer.

As soon as planted, the branches of the young tree should be pruned back at least one-half their growth, and generally it is well to cut back to about four buds. The cutting of the roots when the tree is taken from the nursery necessitates cutting back the top, else the tree may wither and die.

In colder parts of the country the best results will be had by starting the top within one to two feet from the

ground, as the trees will be much better protected than if the branches started higher up. It is possible that orchard culture, even in the best apple-growing districts, may be so modified in the future that it will be found that the best results will be obtained from trees branching out almost from the ground.

Two- or three-year-old trees are, as a rule, the most satisfactory kind to plant, as when they are older than three years, growth is so checked and the trees so stunted by transplanting, that it is not at all desirable to plant them when they are so old. Furthermore, the freight or express will be less on smaller trees. If low-headed trees are desired they may be planted when one year old, if the growth is strong, and cut back to the desired height, leaving only the bare stem. The ordinary farmer, however, who may not give his trees much attention, requires a tree two or three years old, so that it may easily be seen if he grows other crops in the orchard. Trees should be procured from reliable nurserymen, as it is important to have them true to name and well shaped. A local nurseryman is best if he carries good stock. It will pay to get the highest grade of trees offered. Stunted, unshapely trees will never give the same results as healthy, straight ones.

The two- or three-year-old trees should have the heads well formed when received from the nurseryman. The best head consists of a central leader, with three or four side branches rising alternately from the trunk. If the branches are opposite, a crotch is formed and when the tree is heavily laden a branch may be easily broken. It is not always possible to get a central leader, and the next best top is one with from three to five branches rising alternately from the main trunk, forming a symmetrical head. Cherry and plum trees may be planted at one year old with good results.

CHOICE OF VARIETIES

In planting simply for home use, a few trees of early, late fall and winter varieties should be chosen, though in many localities it will be best to secure the winter varieties by top grafting.

In a commercial orchard it is best to limit the varieties to a few of those known to succeed well in the neighborhood. Speaking generally, the largest planting had best be of late fall varieties that are known to sell well. Early varieties are usually a sure crop, and if proper market facilities are available can be made profitable. The more a grower has of one variety, the better he can usually sell his crop.

THE CULTIVATION OF THE ORCHARD

The general experience in New Brunswick is that for the first ten years after planting, apple trees do best if the ground is kept cultivated. Potatoes and all kinds of hoed crops can be grown among the trees, and if a strip four or five feet on each side of the tree is left uncropped the trees will not suffer. This strip should be kept stirred at least once a week from early spring till the 1st of July, when it may be seeded to clover or peas with advantage. This growth should be allowed to lie upon the ground during the winter, to be ploughed in the next spring. When the land is being manured for the crops the strip along the trees should receive a liberal dressing, especially if the land is light and leachy. As the trees grow the strip of land not cropped should be wider until, as the branches spread, it will be better not to crop at all. Clover may be grown frequently with advantage among the trees, but it will pay not to remove the hay from the land. Let it

decay there and very much less manure will be required to maintain fertility.

In addition to growing and turning under or leaving upon the land clover or other legumes, the application of potash and phosphatic manures is desirable. Occasionally some barnyard manure should be applied. The best results can be obtained only when all the elements necessary for tree growth and fruit production are present in abundance and in a more or less immediately available condition.

A crop of 160 barrels of apples to the acre will remove from the soil, as determined at the Central Experimental Farm, about 9 pounds of nitrogen, $5\frac{1}{2}$ pounds of phosphoric acid and 33 pounds of potash.

The growth of the tree demands a considerable additional quantity. It is estimated that five tons of barnyard manure applied annually per acre will support heavy bearing trees.

Arguments *pro* and *con* between cultivating the orchard and leaving it in sod are many, but experience seems to show that cultivation generally gives best results; but nevertheless, especially in a moist climate, excellent crops of apples are grown when the trees are in sod. If the grass crop is not removed from the land, but cut and allowed to remain, and fertilizers are applied frequently, good results are obtained. On rocky land that cannot be cultivated excellent bearing orchards are found when they receive intelligent attention.

PRUNING

There are several objects in pruning trees, the principal being the production of well-colored fruit of good size, in paying quantities, and the maintaining of a symmetrical

top and well-balanced tree to bear this fruit. Trees will bear fruit without pruning, but it is small in size and not so attractive. Unpruned trees, also, are likely to bear heavily one year and have no crop the next. Pruning lessens the number of apples produced, and the tree not being so much exhausted at one time is likely to bear more regularly. It does not exhaust a tree as much to bear a good crop of fine fruit as it does to produce a heavy crop of small fruit, as the exhaustion of the tree is in proportion to the number of seeds matured, and not to the size of the fruit.

Trees should be pruned regularly, beginning when they are young. If much pruning is done at one time it would be likely to injure the tree. When the trees begin to grow thriftily many new branches will be formed, and it is the work of the pruner to remove all those that are not necessary and to cut back others. The top of the tree should be kept open, to admit air and sunlight, but pruning should be so carefully done that there will be no bare limbs. All branches which are growing across and through the top should be cut out. If two branches touch one another, one of them should be removed. If a branch on one side of the tree has outgrown the other, it should be headed back so as to make the tree symmetrical, cutting it off just above a bud which is on the side that it is desired to have the new growth. If, when the trees are young, they are treated in this way every year, comparatively little work will have to be done at one time. The best time to prune is between the middle of May and the middle of June, when the trees are growing thriftily, as the wounds will heal over quicker if done at that time; but as this is a very busy season of the year the customary practice is to prune during the month of March, when quite satisfactory results are obtained. By pinching off

young growth, which is not required, in summer, labor will be saved in pruning. It is much better to prune at any time of the year than to neglect it altogether, as the time of year is not a matter of great consequence. The tools used should be a sharp pruning knife and a fine saw; the branch should be cut off close to the limb or trunk from which it is removed and the cut should be as clean and smooth as possible. A bad practice in pruning, and a very common one, is to leave a stub of the branch cut off. In many cases this never grows over; rot sets in and reaches the heart of the tree, and eventually ruins it. A clean, close cut will heal quickly and needs no paint or wax, unless a large limb has been removed.

Unfortunately, too many of our farmers and fruit growers neglect pruning their trees regularly, the result being that when they begin, it is necessary to remove many large limbs. In cases of this kind it is not wise to do too much pruning in one season, as a severe pruning of the tree will cause so much young growth that it will be necessary to thin it out. It will also expose the limbs which have been protected, and may cause sunscald. A better practice is to do it regularly. If large limbs are removed, the wounds should be given a coating of grafting wax or lead paint, which will protect them from weather and prevent rot from setting in until they begin to heal over.

It is a well-known fact that winter or spring pruning tends to the production of wood; and summer pruning, to the production of fruit buds. The reason of this is that pruning before growth begins, or when it is beginning, destroys the balance between top and root, and there being then more sap supplied by the roots than the remaining top can elaborate, stronger growth is made or new branches formed to readjust this balance. If pruning or pinching off part of the new growth is done in the

summer after most of the growth has been made, a part of the elaborated sap, which is as necessary to the production of strong roots as it is to the production of top, is removed, and the tree is checked in its growth and weakened, although the pruning should not be so severe as to make the latter apparent. A weakening of this kind tends to the development of fruit buds. Summer pruning to produce fruitfulness is seldom necessary, however, and it is not recommended. If trees are given even a fair measure of attention they will reward the owner with abundant crops. Some varieties of apples do not come into bearing as quickly as others, and often growers think that something is wrong with these trees when they do not bear early.

INJURY BY MICE

Field mice, especially in a winter when there are crusts on the snow, frequently kill young apple trees by gnawing off more or less of the bark around the trunks. To prevent them, all rubbish in which they are likely to harbor should be removed from the orchard, and the young trees may be protected by wrapping the trunks with paper, veneer or wire netting; shovelling earth up into a mound about the tree before the ground freezes will frequently avert this damage; it is besides a good practice because it holds the tree steady during winter storms and sheds the water off, preventing any ponding or freezing round the collar of the tree.

INJURY FROM SUNSCALD

It sometimes happens, particularly if the orchard is on a southern or southwesterly slope, that a continuance of bright weather in March and April will scald the trunks of the trees. A veneer of wood, a roll of birch bark,

building paper, corn stalks or anything that will keep off the sun may be used. Where the trees are wrapped to prevent mice, the same wrapping will prevent the sunscald. A coat of whitewash is also a good preventive, and spraying with lime wash is an excellent treatment for the trees both in the late autumn and early spring. It will remove bark lice and other scales, rough bark, etc., and give the tree a clean, healthy bark.

DISEASES AND OTHER INJURIES TO APPLES AND APPLE TREES

APPLE BLIGHT OR FIRE BLIGHT (*Bacillus amylovorus*)

This disease often does much injury to apple trees. It is usually first indicated by the sudden drying up of the young twigs and spurs. Often whole branches will be affected and sometimes the trunk itself, causing the tree to die or become practically useless. The bacteria which cause the disease enter through the blossoms and bark of the tree. The Russian varieties of apples appear more subject to it than others. There is no known preventive or good remedy. Affected twigs and branches should be cut off about a foot below the affected part and burned to prevent the further spread and dissemination of the disease.

BLACK SPOT FUNGUS OR SCAB (*Fusicladium dendriticum*)

During recent years the apple scab fungus has been very troublesome, often injuring the fruit so badly that it is quite unsaleable. The disease attacks the tree early in spring, and is first noticeable as light green patches on the young leaves. The fruit may be affected as soon as formed, and if badly diseased will drop off. As the fruit

increases in size the diseased patches enlarge and nearly all the surface is often covered with the black spots before the fruit is picked. In addition to the disfigured appearance of the fruit, caused by this disease, the apples do not reach their full size. The apple scab develops most rapidly in moist weather. This disease may be almost entirely prevented by the proper use of Bordeaux mixture, the remedy recommended at the end of this paragraph. While a certain number of applications are recommended, more will have to be given if the season is wet. The object should be to keep the trees covered with the mixture from the first until the last spraying. If the mixture is washed off the tree the disease will have an opportunity of developing, and it is difficult to check it when it begins to spread.

Remedy.—Spray with copper sulphate solution (1 pound of copper sulphate to 25 gallons of water) before buds start ; and with Bordeaux mixture, just after blossoms open ; soon after blossoms fall and two or three times after at intervals of from 10 to 15 days. The first three sprayings are the most important.

CROWN GALL (*Root Gall*)

Indicated by hard, gall-like masses on the crown and sometimes on the roots of apple trees, particularly on young trees. These galls often interfere very much with the circulation of sap in the trees, causing them to become sickly, and frequently resulting in their death. The roots of most of the large fruits are affected, and in the United States the losses from this disease have been very great. Until recently, it was not known what caused this injury. It was thought by some that the galls were simply malformation caused by an injury to the tree or were produced by unsuitable soil ; by others, that they were produced by a parasitic fungus, and again that they were caused by

insects. This disease has been given much study recently by J. W. Toumey, of the Arizona Agricultural Experiment Station. His conclusions are that it is caused by a parasitic slime-mould, the spores of which may be readily disseminated by the wind or by other means. No remedy has yet been found, and trees affected with it should be destroyed and burned to prevent its spreading. If only the galls are removed, they will grow again. No trees should be planted which have had these galls upon them.

DRY ROT

This is a disease which affects the fruit, and is indicated on the exterior of the apple by small circular depressions. When the skin is removed, dryish brown tissue is found at the diseased spots, and when the fruit is badly affected this brown and pithy condition may be seen extending through much of the fruit. The diseased flesh is not bitter, but is dry, tough and without flavor. When the apple is badly affected its commercial value is almost destroyed. Various causes have been assigned for this disease : namely, want of vigor of tree, lack of moisture in the soil, want of potash and lime in the soil. By those who have given most study to the rot it is ascribed to the concentration of sap caused by the transpiration of moisture, which causes the death of the cells. There is not yet any known remedy for this disease, but it will probably not be as troublesome if there is plenty of moisture in the soil, and if the trees are encouraged to make good, healthy growth.

INJURIOUS INSECTS

In a condensed consideration of the most important insect enemies of the apple grower, it may be pointed out that these may be divided under the following headings :

Those which devour the foliage ;
 Those which bore in the wood ;
 Those which occur in the bark ; and
 Those which attack the fruit.

All insects fall within two classes which can be separated by the nature of their mouth parts. A consideration of this point is of the utmost importance in the intelligent use of remedies. In the first class—Biting Insects, which have jaws with which they consume the substance of their food, as caterpillars—all that is necessary is to place on the food plant some poisonous material which will be eaten with the food. In the second class—Sucking Insects, which instead of jaws have a beak or hollow tube with which they suck up their food in a liquid form, as the plant-lice—something must be used which will kill by mere contact with their bodies.

For some insects, such as borers in the wood, which cannot be reached by the above remedies, preventive measures may be taken by which the plants are rendered distasteful to the mature insects when seeking a suitable place to lay their eggs. For this purpose, various alkaline or strong-smelling deterrent washes are used.

The following are the formulæ of standard remedies which are recommended by the Experimental Farm authorities :

INSECTICIDES AND FUNGICIDES

I. Kerosene Emulsion

(Riley-Hubbard formula)

Kerosene (coal oil)	2 gallons.
Rain water	1 gallon.
Soap	$\frac{1}{2}$ pound.



1
3
3
3
8
1

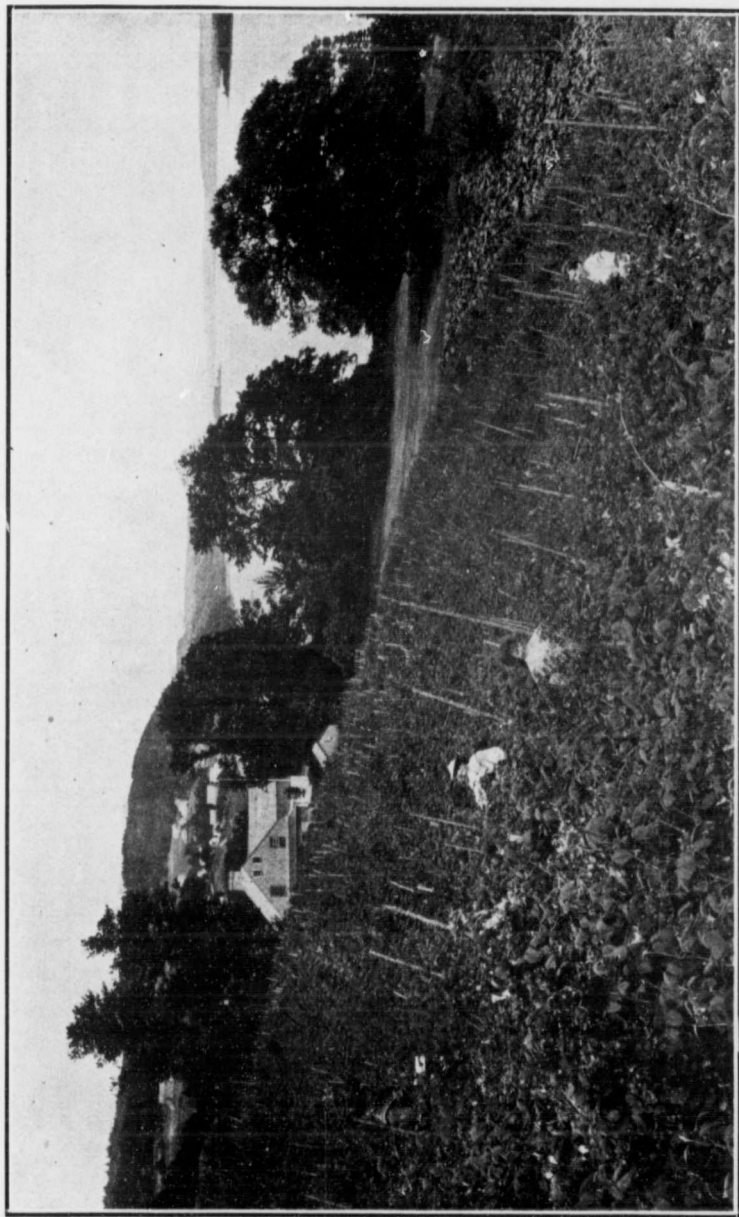

A FIELD OF RASPBERRIES ON THE KENNEBECASIS RIVER.

Dissolve soap in water by boiling ; take from fire, and, while hot, turn in kerosene and churn briskly for five minutes. To be diluted before use with nine parts of water.

II. Paris Green

Paris green	1 pound.
Lime (fresh)	1 pound.
Water	200 gallons.

For dry application. One pound Paris green with fifty pounds of flour, land plaster, slaked lime or any other perfectly dry powder.

III. Whale Oil Soap

For scale-insects (young)	1 pound in 5 gallons water.
For aphid	1 pound in 8 gallons water.
For San Jose scale (in winter)	2 pounds in 1 gallon water.

IV. Tobacco and Soap Wash

For Plant Lice or Aphid

Soak in hot water for a few hours ten pounds of tobacco leaves (home grown will do) ; strain off and add two pounds of whale oil soap. Stir until all is dissolved, and dilute to forty gallons. Apply early and two or three times at short intervals.

V. Alkaline Wash

For Borers

Soft soap reduced to the consistency of thick paint by the addition of a strong solution of washing soda in water. If applied with a brush during the morning of a warm day, this will dry in a few hours and form a tenacious coating not easily dissolved by rain.

VI. *Poisoned Bordeaux Mixture*

For Fungi and Insects on Fruit Trees

Copper sulphate (blue-stone)	4 pounds.
Lime (fresh)	4 pounds.
Paris green	4 ounces.
Water (1 barrel)	40 gallons.

Dissolve the copper sulphate, by suspending it inside a wooden or earthen vessel containing four or five or more gallons of water. Slake the lime in another vessel. If the lime, when slaked, is lumpy or granular, it should be strained through coarse sacking, cheese cloth or a fine sieve. Pour the copper sulphate solution into a barrel, or it may be dissolved in this in the first place; half fill the barrel with water, add the slaked lime, well diluted, fill the barrel with water and stir thoroughly. It is then ready for use. Add the Paris green by moistening into a paste, then diluting and pouring into the barrel. This mixture must be kept well stirred while using.

Stock solutions of dissolved copper sulphate and of lime may be prepared and kept in separate covered barrels throughout the spraying season. The quantity of blue-stone, lime and water should be carefully noted.

VII. *Copper Sulphate Solution*

Copper sulphate (blue-stone)	1 pound.
Water	25 gallons.

As soon as dissolved it is ready for use. For use only before the buds open.

"Spraying" consists of applying liquids by means of a force pump and spraying nozzle, with such force as to break up the liquid so thoroughly that it falls upon the plants treated as an actual mist or spray. Such terms as

sprinkling and showering are inaccurate for the operation here intended. Unfortunately much of the so-called spraying as usually carried out, could more accurately be designated by these terms, which describe a much less careful and less even distribution of liquids. An outfit of pump and nozzles which will make a fine spray and rapidly accomplish the necessary work is an absolute essential for the fruit grower.

INSECTS ATTACKING THE FOLIAGE

1. The Eye-Spotted Bud-Moth (*Tmetocera ocellana*). Small, dark brown caterpillars, quarter of an inch in length, with black heads and collars, destroying the buds when just unfolding, and sometimes boring down the centre of the twig.

Remedy.—Spray early with strong Paris green wash (Paris green 1 pound, fresh lime 1 pound, water 100 gallons).

2. The Cigar Case Bearer (*Coleophora Fletcherella*) and
3. The Pistol Case Bearer (*Coleophora malivorella*). Small yellow caterpillars in curved cases, which pass the winter on the twigs of apples and cluster around the opening buds, injuring the foliage and flowers.

Remedy.—Spray early with the wash mentioned under No. 1 above, or with kerosene emulsion (Formula I).

4. Leaf-Rollers. The caterpillars of several small Tineid moths, when full grown from $\frac{1}{4}$ to $\frac{1}{2}$ inch in length, which bind together the young leaves and flower buds, forming a tent inside which they feed.

Remedy.—The same as for No. 1.

5. Tent Caterpillars (*Clisiocampa*). Two kinds attack the foliage of the apple as well as of many other trees. The

Apple-tree Tent Caterpillar forms a tent in the fork of two twigs; the Forest Tent Caterpillar does not make a conspicuous tent, but spins a flat mat of silk on the side of a branch or on the trunk; to these resting places the young caterpillars resort when not feeding. The mature insects are thick-bodied, reddish-brown moths expanding about $1\frac{1}{2}$ inches across the wings, which are crossed obliquely by two bands. These bands are pale in the first-named but dark in the moth of the Forest Tent Caterpillar. During July the females lay rings of about 200 eggs on the twigs of trees, in which state the insect passes the winter.

Remedies.—Collect and destroy the egg clusters during the winter. Spray the trees with poison (Formula II or VI) directly the young caterpillars are noticed. All tents should also be cut off and destroyed early before the leaves hide them.

6. Green Fruit Worms (*Xylina*). Green caterpillars dotted and lined with yellowish white, $1\frac{1}{2}$ inches long, occasionally attacking the foliage and the forming fruit.

Remedy.—Spraying regularly with Formula VI will prevent injury from these insects.

7. Cankerworm (*Anisopteryx pometaria*). Silver brown caterpillars about an inch in length, with only six pairs of legs, occurring sometimes in large numbers, attacking the leaves so severely as to give the trees the appearance of having been scorched by fire. The wingless female moths appear only in autumn, and climb up trees to lay their eggs in flat patches on the bark. From these the young caterpillars hatch in spring.

Remedies.—Spray as soon as caterpillars appear with Formula II or VI. In autumn, place mechanical contrivances or bands of thick paper painted with a mixture of castor oil, two pounds, resin three pounds; or with printer's ink, or some other viscid substance, to catch the females when ascending the trees to lay eggs.

8. The Apple Aphis (*Aphis mali*). During winter small shiny black eggs may be found on the twigs. From these, early in spring, green plant-lice hatch and cluster on and in between the young leaves of the opening buds. They also occur in large numbers beneath the leaves in autumn.

Remedies.—Tobacco and soap wash (Formula IV); whale oil soap, 1 pound in 8 gallons of water (Formula III).

INSECTS ATTACKING THE WOOD

Borers — Flat-headed Borer (*Chrysobothris femorata*); Round-headed Borer (*Saperda candida*). The above named are the two commonest kinds of borers which attack the apple. They vary somewhat in their habits, but the best remedy for both is undoubtedly a regular treatment every June, just before the time the eggs are usually laid, with deterrent washes, such as Formula V, or the same with crude carbolic acid added, in the proportion of 1 pint to 4 gallons of the wash, to be applied with a large brush to the bark of the trunk and larger limbs. When a tree is infested, the presence of the grub may be detected by the borings which it pushes out of its burrows and by the sunken, discolored appearance of the bark. By cutting through the bark the grub can be destroyed. If it has penetrated into the wood, it can be killed with a piece of stout pliable wire.

The Oyster-shell Bark Louse (*Mytilaspis pomorum*). Small scale insects furnished with a beak and protected by a waxy scale one-tenth of an inch in length, shaped somewhat like an elongated oyster-shell. The young lice hatch in spring about 15th of June, when they possess legs and are active for a few days only; at this time they are soft and unprotected. There is only one brood in the year.

Remedy.—Spray the trees during winter with lime wash (1 or 2 pounds of fresh lime to a gallon of water); or when the young scale insects hatch, spray with kerosene emulsion (Formula I) or whale oil soap (Formula III).

There are several other kinds of scale insects which occur upon the apple, which may be treated in the same way as the Oyster-shell Bark Louse.

Fortunately for us, as yet the San José Scale has not been found in this province. It is a very destructive minute scale insect. What is known as the Lime-Sulphur wash is the best destructive agent.

The Woolly Aphis (*Schizoneura Lanigera*). Clusters of white, downy plant-lice, causing wart-like excrescences on the roots and stems or around wounds where a branch has been cut off. This insect is seldom a serious pest in New Brunswick, but is very troublesome in the West.

Remedies.—Spray the colonies on the branches and trunks with kerosene emulsion or a wash made with 1 pound of concentrated lye and 1 pound of whale oil soap in 5 gallons of water. For the root colonies, remove the surface soil to a depth of 6 inches, for a foot or two around the trunk, and dig in tobacco dust or refuse from a tobacco factory.

INSECTS ATTACKING THE FRUIT

The Codling Moth (*Carpocapsa pomonella*). This is the parent of the destructive apple worm so well known to all growers and consumers of apples all over the world. In New Brunswick there is only one regular brood of the insect; west of Toronto there are two broods, the latter of which is by far the more destructive. Where there is only one brood, spraying with Paris green (Formula II or VI) three or four times in the spring, beginning immediately after the flowers have fallen, at intervals of ten days, is all that is required.

Besides protecting apple trees from the attacks of the Codling Moth, spraying with the poisoned Bordeaux mixture (Formula VI) as advised above, will destroy many other enemies which feed on the foliage, such as Cankerworms, Tent Caterpillars, Leaf-Rollers, etc.

The Apple Maggot (*Trypeta pomonella*). Slender white footless maggots, one-fourth of an inch in length, tapering gradually to the head and cut off abruptly behind, burrowing in all directions through the flesh of apples, feeding on the pulp and leaving brown channels. There are sometimes as many as a dozen maggots in a single apple. Infested fruit ripens prematurely and falls, when the maggots leave and, entering the soil a short distance, form puparia, inside which they remain unchanged until the following spring.

Remedy.—Spraying is useless against this insect. The remedy most to be relied on is the prompt destruction of windfalls so as to prevent the maggots going into the ground. This can best be done by keeping a sufficient number of pigs, sheep or other stock in the orchard. The penning up of poultry beneath infested trees has been found a most useful practice.

PICKING, PACKING AND MARKETING

These are the final acts in the drama of fruit growing, and they demand the utmost attention, else the orchard investment may be an entire failure from a financial standpoint. When the fruit supply becomes large there are usually fruit buyers who will buy the crop upon the trees; but this is not always, perhaps seldom, the best plan for the grower, for the buyer in making the bargain must protect himself against a downward tendency in the market, and his pickers who have no interest in the trees are liable to destroy many branches while picking the crop.

Best success is being obtained by co-operation among growers, who are thus controlling their own warehouses and are able to deal direct with large foreign buyers and can eliminate to some extent agents' commissions.

Each variety of apple has its own best time of picking. Early apples intended for local consumption should be left on the tree until well colored and almost ripe. They are best marketed in baskets or boxes. For export, they must be picked less mature and cooled down before shipping.

Winter varieties may be left on the trees till there is danger of their freezing. Great care must be taken in picking and packing to avoid bruising the fruits. Apples intended for market must always be carefully hand-picked into lined baskets and all the handling carefully done. For sorting they should be placed on padded tables.

Under the "Fruit-marks Act" packers of fruit for sale must observe certain rules in grading their fruit and marking their packages, and should familiarize themselves with these regulations.

Box packing is done by placing every apple by hand according to a definite system in the box, and the box must be made of a definite size with ends of three-fourth inch lumber, sides one-half inch and tops and bottoms one-fourth inch, so that they may be springy and not rigid.

A legal barrel must not be smaller than $26\frac{1}{2}$ inches between the heads; 17 inches in diameter at the heads and $18\frac{1}{2}$ inches in the bulge of the barrel. In packing barrels, the first two layers are carefully placed by hand, then the apples carefully filled in from a basket, and after each basket is emptied the apples should be settled into place by carefully racking the barrel upon a solid plank not more than nine inches wide. The barrel should be

filled to a little above the head groove and then gently pressed down with a padded head by screw pressure, not hard enough to break or bruise the apples, but sufficiently hard to hold them tight till they arrive at their destination.

New Brunswick is not now growing nearly enough fruit to supply her own markets, and she has the winter port of Canada through which hundreds of thousands of barrels and boxes are being shipped to Europe, so that the market outlook for the fruit-growers of this province could not be brighter; and when we begin to appreciate that we have here one of the best apple-growing belts in America, we will make orcharding the important industry it is destined one day to become.

PEARS, PLUMS AND CHERRIES

What has been said thus far in regard to growing fruit trees with special reference to the apple, applies equally to other trees. Pears are not generally grown, but many varieties can be if good apple tree conditions are given them. Plums are easily grown, but unfortunately the disease known as "Black Knot" has followed them so closely and has been so hard to fight that it has discouraged most growers. Added to this scourge is the great difficulty of marketing plums owing to their perishable nature; and these drawbacks, as well as a rather limited home market, furnish three excellent reasons why plums are not extensively cultivated. There are many varieties of this fruit, some of which, mostly of Japanese or Chinese origin, are comparatively long keepers, and these kinds are likely to be most popular in future.

Cherries also are a perishable fruit, and while the trees will grow as well as apple trees, black knot, perishability of fruit and limited market demands, are conditions which

do not at present hold out much encouragement to extensive cherry growing.

A few plum trees and cherry trees should, however, be planted close to every home, to supply the family with healthy and refreshing fruit, whether it be eaten fresh, canned or preserved.

SMALL FRUITS

The most generally grown small fruit, and the fruit which has been most largely exported, is the strawberry.

Strawberry culture was first introduced into New Brunswick at Kingston, Kings County, about 1862, by the late D. P. Wetmore, Inspector of Schools. For some years the village of Clifton grew practically all the berries grown in the province and they sold readily in St. John market at from twenty to twenty-five cents per box. After some ten years the crops became too large for the St. John market, and beginning in 1875, quite large shipments were made to Halifax, Boston and Montreal. From 1880 on, strawberry growing became more general through the province, nearly all the growers getting their original plants from Clifton.

In 1880 the strawberry crop of Kingston parish was about 40,000 boxes; in 1909 it was in the vicinity of 500,000 boxes.

VARIETIES

The "Wilson Albany" was the great berry in the early years. It was firm, a good shipper and a favorite in the local market. Some growers have continued to plant this variety till quite recently, but it latterly lost all its old-time vitality and yield. The Downes Prolific was also a favorite, and it, with the Wilson, made more

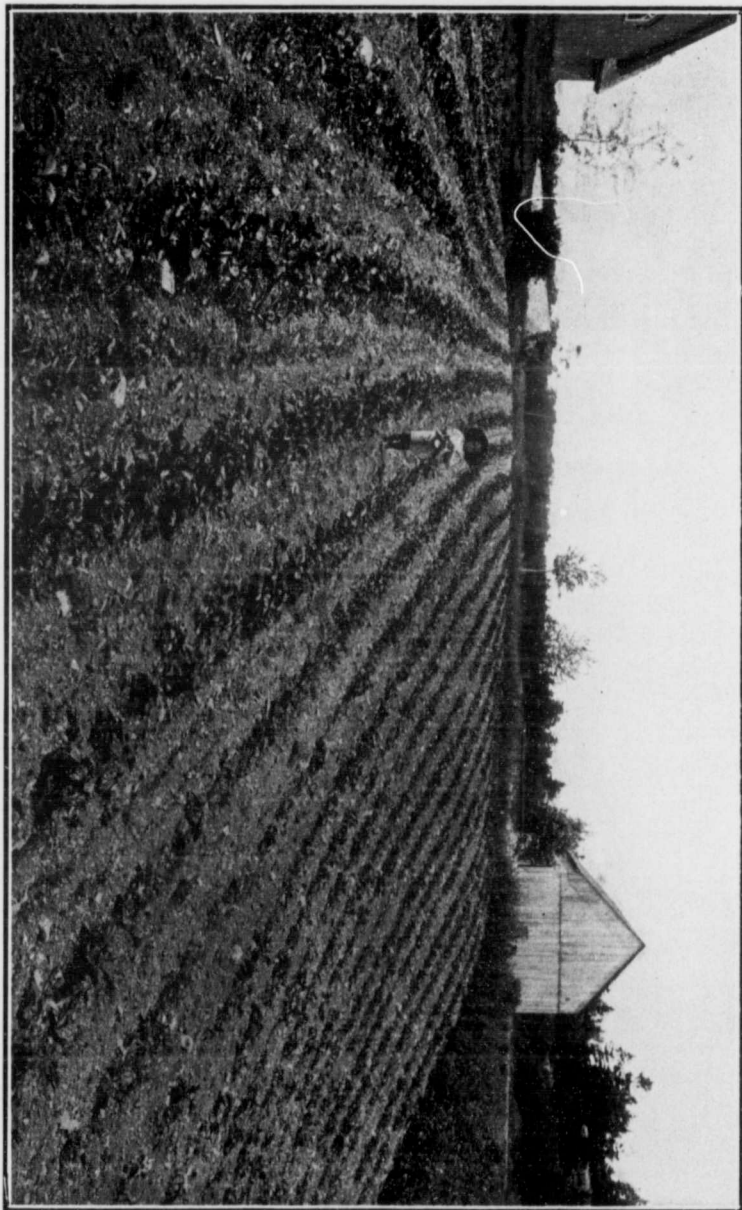

A STRAWBERRY FIELD AT CLIFTON, N.E.

mo
all
pe
ma
ma
fec
lat
an
cia
ne
Th
so

gr
in
be
fir
all
he
as
pi
th

lar
for
be
an
wi
m

gi

money for the growers in the first fifteen years than did all others. Yields were obtained as high as 10,000 boxes per acre. Later the Crescent Seedling was a great market berry, was popular all over the province, and made a lot of money for the growers. It had an imperfect blossom and needed the Wilson as a pollinizer. In later years the Sample (a good home berry and shipper) and the Glen Mary have proved two of the best commercial berries. The Sample has an imperfect blossom and needs a variety such as the William Belt as a pollinizer. The Warfield and Senator Dunlop are varieties good in some localities but apt to run small.

CULTIVATION

Any land that will give a good crop of potatoes will grow strawberries. Manure should be liberally applied in the fall and worked into the soil. The plants are best set in the spring in deep furrows, with soil well firmed around them. In the early years the plants were allowed to mat in wide rows, but later a more narrow or hedge row is used, with the result that the yield is about as large and the berries a finer sample and easier to pick. The light and air reach the berries better and they ripen more evenly.

The fall application of manure is well worked into the land the following spring. Land can hardly be too rich for strawberries, and muriate or sulphate of potash can be added with great advantage, making the berries firmer and larger. Some growers obtain large crops of berries without barnyard manure by the use of a complete commercial fertilizer.

If they make a good stand, strawberry plants usually give their best yield the first year after setting; the

berries are larger, firmer and better in every way than from succeeding crops, though if the plants are cultivated immediately after picking and the weeds cleaned out, they generally make a pretty healthy growth, and in some cases the second and even the third year's bearing has been lost. Mowing and burning the old plants has been tried, but cannot be considered successful in prolonging the life of the patch.

SETTING NEW BEDS

Successful growers always set plants every year, and best results are had by setting as soon as the mulch is removed from the plants, which are then practically dormant and the change in transplanting has least effect upon them. When strawberry plants are taken up for resetting, they should always be packed in damp moss; more plants are lost by careless exposure to the air when being reset than in any other way. Only the new runner plants should be used for resetting, and care must always be taken in setting plants never to plant varieties with imperfect blossoms alone. Every fourth or fifth row should be of a variety that has good strong pollenizing or perfect blossoms. The pistillate varieties are almost worthless planted alone, but give wonderful yields when properly fertilized. The "William Belt" is a good variety to plant with "Sample," and "Senator Dunlop" with "Warfield." "Glen Mary" has just about enough pollen to fertilize itself.

Strawberries must be mulched in the winter, and the best time to apply the mulch, which may be straw or coarse manure just thick enough to cover the plants, is as soon as the ground is frozen. It should be removed about the first of May.

PICKING AND MARKETING

Nearly all varieties will carry to the local market if picked every other day, but for shipping they must be gone over every day, else some will get too ripe. "Sample" will ripen enough berries each day to make a good pick and ripen evenly. Strawberries should be picked and shipped as quickly as possible. Berries can be picked in the morning, shipped in the afternoon, and arrive in Boston, Montreal or Halifax early the following day. The packing should be done in a cool shed. The top layer of berries in the box is usually turned down, making the berries carry more steadily and look better.

YIELD OF CROP

A good fair yield is 6,000 boxes to the acre ; a rate as high as 14,000 boxes to the acre has been reached in one-quarter and one-half acre plots. The average yield per acre will be between 4,000 and 5,000 boxes.

Success in getting a good price for New Brunswick berries seems to depend largely upon having them late enough to follow the crop from other and earlier districts. For several years prior to 1908 prices netted the growers in the field from 7 to 9 cents a box. That year the price was 9 cents, but in 1909 the net price was only a little over 6 cents, largely because New Brunswick berries were somewhat earlier, and other districts supplying Montreal and Boston were later than usual.

Experience seems to show that the best prices can be obtained by delaying the ripening of berries as much as possible. This can be done to some extent by planting on northern exposures and leaving the mulch on in the spring as late as possible. It must not be left, however,

after the plants start to grow, as they will be too tender for good results.

OTHER FRUITS

There are various other small fruits, Raspberries, Blackberries, Gooseberries, Currants, etc., which are grown successfully and should be found in every garden. As commercial crops, the difficulty of getting them to outside markets militates against them; a considerable quantity, however, can profitably be grown for local demands. The best systems of cultivation, propagation and care are worthy of study. Full information can be obtained in Bulletins and Reports from the Dominion Experimental Farms.

Cranberries of various kinds are valuable market crops, as they will carry to almost any market, and high prices are paid.

Wild Raspberries, Blackberries, Blueberries, Huckleberries and other native fruits are all more or less valuable; blueberries especially being a large export crop. But little is known as to the best means of securing crops of this berry. The bushes come naturally upon burnt land, and sometimes serious forest fires are caused by some one's desire to burn an area for the purpose of securing a blueberry crop.

There is room for great development in fruit growing under the favorable natural conditions which New Brunswick affords; and opportunities exist in this province for thousands upon thousands of prosperous and happy horticulturists who will help to make it one of the best home lands under the canopy of heaven.

COI

“
from
and vA
pretl
and
wher
of cl
wher
mead
weed
injur
Man;
incre
most
duce
Prov.

COMMON WEEDS OF NEW BRUNSWICK

BY

D. WILEY HAMILTON, M.A., PH.D.

PROVINCIAL NORMAL SCHOOL, FREDERICTON, N.B.

“Most young people find botany a dull study. So it is, as taught from the text-books in the schools; but study it yourself in the fields and woods, and you will find it a source of perennial delight.”

—JOHN BURROUGHS.

“Flower in the crannied wall,
I pluck you out of the crannies,
I hold you here, root and all, in my hand;
Little flower—but *if* I could understand
What you are, root and all, and all in all,
I should know what God and man is.”

—TENNYSON.

A weed is a plant out of place. “Few flowers are prettier than the Ox-eye Daisy, and Black-eyed Susan; and a bunch of either will readily command a few cents, when offered to the denizen of the city whose memories of childhood’s days are recalled by the wildings. But when they take possession of a clover field, the hay meadow, and the pasture, the farmer regards them as weeds.” Any plant that is troublesome, unsightly, or injurious, and of little or no use, is regarded as a weed. Many of our native plants may under favorable conditions increase rapidly and become weeds, but nearly all our most troublesome and aggressive plants have been introduced from other countries. Fifty years ago, in this Province, weeds were not a serious menace; but as the

country grows older, as new sections are opened up for settlement and new railways built, new plants are introduced. To-day, in many parts of the Province, weeds are a source of constant and very considerable loss to the farmer. When farmers fully realize what great damage weeds occasion, self-interest will be a sufficient incentive to destroy as many as possible.

In order to intelligently deal with noxious weeds, some knowledge of their life-habits is necessary. As regards duration, plants may be classified as *annuals*, *biennials* or *perennials*.

Annuals complete the life-cycle, from seed to seed, in one growing season; biennials require two growing seasons, and perennials may live several years. Methods of eradicating annuals may not suffice for biennials or perennials. As a rule, annuals, for example Wild Mustard, Wild Buckwheat, Ragweed, etc., have fibrous roots and extraordinary powers of seed production. A single Wormseed Mustard plant may produce 25,000 seeds. An annual sets off against its shortness of life the power to produce a great many seeds. To destroy annuals stubble ground should be cultivated frequently after the removal of the harvest. This prepares a suitable seed-bed for the germination of the weed seeds. Cultivation will kill the young seedlings as they appear. In this way the weed seeds are quite well cleared out to a depth of 8 or 10 inches, and below that depth few seeds can germinate. Young seedlings, appearing late in the autumn, are usually killed by the severe frosts. In general, prevention of seeding, frequent shallow cultivation, and mowing fields and roads will keep most annuals in check.

The same methods are applicable to biennials before they have developed tap-roots or rootstocks. Cutting

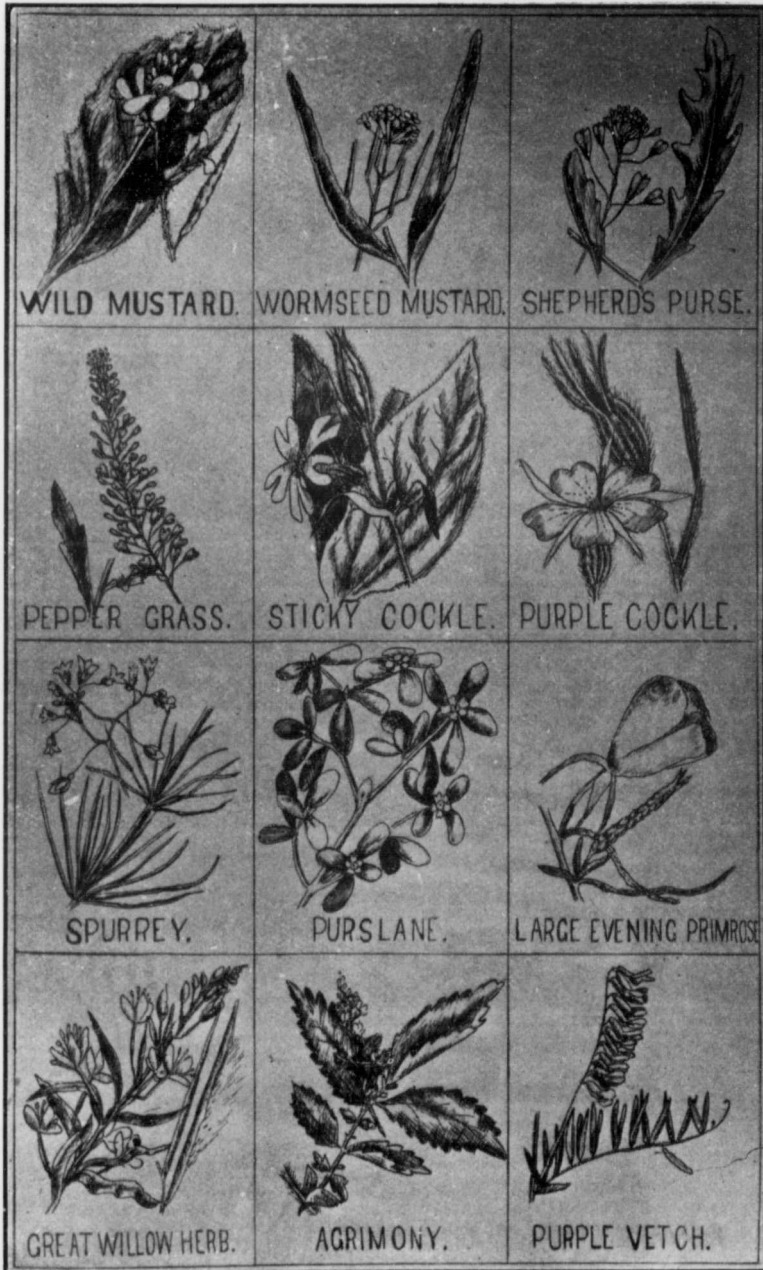

biennials below the crown with a spud in sod land, or deep and frequent cultivation in arable land will kill them. Spudding is best done in the fall when the roots and stems are tender.

Some perennials, as Canada Thistle, have underground creeping stems ; others, as Chicory, have roots which do not spread horizontally but are quite deeply rooted. For shallow-rooted perennials frequent cultivation, and for deep-rooted perennials spudding and cutting, so as to prevent the plant from forming foliage, thus starving the roots, are the best general methods of eradication. The treatment which weeds should receive must necessarily vary with the conditions. Special weeds require special treatment. There are, however, some general principles, or methods of eradication, that may be outlined as follows :

1. Weeds should not be allowed to seed.
2. Weed seeds should not be sown.
3. Weed seeds already shed or sown should be destroyed soon after germination.
4. Complete eradication is brought about only by the actual removal of the plants.
5. Burial of plants by ploughing or deep cultivation will destroy most mature annuals, and the seedlings of biennials and perennials.
6. Spudding, or cutting deep-rooted stems below the surface of the ground, is sufficient to destroy most plants. The plant is starved by preventing the development of leaves or other green parts, thus depriving the plant of a supply of carbonic acid gas and oxygen from the air
7. Drainage will eliminate plants which flourish only in wet land.
8. Certain chemical substances, for example common salt, will kill some plants if properly applied.

Not many of our native plants are noxious weeds. Our worst weeds are brought to us from other countries. Man is responsible for the introduction of foreign plants, but natural agencies assist in spreading plants from farm to farm. The natural agencies are :

1. *Winds*.—Very small seeds, and those which have special floats, are wafted long distances by strong winds.

2. *Water*.—Seeds which float may be carried by running water long distances from the parent plant. Darwin maintained that seeds might be carried over one thousand miles by the movements of the water of an ocean, and the seeds would not lose their germinating powers.

3. *Animals*.—The fruits of Burdock, Agrimony, and other plants, which cling to the bodies of animals, may be carried until rubbed off. About ten per cent. of all flowering plants produce seeds which are dispersed by means of barbed processes. Seed-eating birds and herbivorous animals swallow whole many seeds. The latter may pass through the digestive system of the animal without injury, and reaching the ground perhaps many miles from the parent plant, germinate and produce new plants.

The chief human agencies for the dispersal of seeds are :

1. *Impure Grain, Grass and Clover Seed*.—Hay imported for fodder may contain many weeds. In clover and grass seed especially there may be a large number of weed seeds. In order to protect the farmer the "Seed Control Act of 1905" was passed by the Dominion Parliament. The Act is intended to provide the means by which the users of seeds may protect themselves against the introduction of noxious weeds.

2. *Stable Manure*.—Manure brought from city stables often contains many weed seeds, and these are carried to different parts of rural districts.

3. *Farm Implements*.—A threshing machine used on a farm where, through ignorance or neglect, weeds abound, contains numerous seeds in the chaff and other litter remaining

in the machine. When the machine is moved to another farm many of the weed seeds are shaken out.

4. *Trains and Vessels.*—Many of our worst weeds reached this country from Europe in the ballast of vessels. Plants also follow the lines of railways. Seeds are dropped from cars as the train moves along, and litter of various sorts is scattered along the track and at stations where cars are unloaded.

The chief objections to weeds are :

1. *They absorb soil moisture which useful plants require.*—An average Mustard plant takes from the soil about seven-tenths of a pint of water per day, and a Sunflower plant may absorb many times that quantity.

2. *They use plant food.*—Analyses of different weeds show large percentages of potash, phosphates, and sometimes of nitrogen, foods which are supplied the growing crops in the form of expensive fertilizers.

3. *They crowd, choke, and shade useful plants.*—Black Bindweed often covers completely useful plants among which it grows. The seeds of some garden plants germinate very slowly, and the young seedlings are weak. If vigorous, fast-growing weeds are allowed to compete with slow-growing seedlings, the latter are soon smothered, and the yield is small.

4. *They increase expenses.*—Weeds are a source of great loss to the farmer, because much labor, time and expense are required to keep them in check.

5. *They harbor injurious insects and fungi.*

6. *They are sometimes poisonous to stock.*—Thousands of cattle have been killed in Pictou Co., N.S., by eating Ragwort, a poisonous weed brought to this country from Ireland.

7. *Weeds offend the eye and degrade the taste for farming.*—As a rule weeds are not attractive, often they are repulsive, and seldom do they lend beauty to a lawn, garden, or grain field.

SOME COMMON NEW BRUNSWICK WEEDS

GRASS FAMILY

Grasses have hollow stems (called *culms*) closed at the joints, and 2-ranked, straight-veined leaves, each with a long sheath enclosing the stem, with the margins overlapping. The flower is small, and consists of two outer bracts (called *glumes*), two inner bracts (called *palets*), three stamens, and one ovary bearing a seed called a grain.

Barnyard Grass, or Cock's-foot, is a coarse, weedy annual, common in barnyards and in low, rich grounds. It has a stout, thick stem branching from the base, many broad, flat leaves, and numerous little clusters of small green flowers crowded in a dense, large cluster.

Old Witch Grass is a native grass common in gardens and waste places. It is of little agricultural value. The stem is from 12-18 inches high, the leaves and sheaths very hairy, and the small green flowers arranged in a large, loose, compound cluster, often half the length of the plant.

Yellow Foxtail, Pigeon Grass, or Bottle Grass, is an annual weed common in stubble or root-fields. It may be eradicated by cultivating the stubble during the fall and planting a hoe-crop the following season. The plant is erect, 1-2 ft. high, with flat leaves rough above and smooth beneath, the sheath being fringed at the summit. The flowers are tawny-yellow, in a bristly, dense, cylindrical spike. **Green Foxtail** very much resembles Yellow Foxtail, but has a green, less dense spike with fewer bristles. It is an annual of wide distribution.

Couch, Quack, or Twitch Grass, has a bad reputation. Its white, creeping rootstocks penetrate deeply into the ground and possess great vitality. The leafy stem is from 1-3 ft. high, the leaves are flat and rough, and the green

flowers are arranged in 4-8 flowered, alternate clusters, forming a spike 3-8 in. long. Couch grass flourishes in loamy soils, from which it is not easily eradicated. The creeping, underground stems must be removed as completely as possible, and to do this requires good judgment. Each piece of underground stem is capable of independent existence. If the stems are cut by the plough or harrow into small pieces, the pest is multiplied and spread. After ploughing, a heavy drag-harrow brings out the larger pieces, which may be collected by a lighter harrow, and then burned. Hoe-crops of various kinds, shallow cultivation, and close grazing of sod, will help to keep the pest in check.

CROWFOOT OR BUTTERCUP FAMILY

All are familiar with the **Tall Buttercup**, with its erect stem, crowfoot-shaped leaves, acrid, colorless juice, and yellow flowers, the parts of which are separate from each other. A worse weed is **Creeping Crowfoot**, troublesome in pastures. The latter puts forth long runners during the summer, flowers later than the Tall Buttercup, and has three-lobed leaves which are often blotched with white. The plant spreads rapidly by means of its runners and is abundant in New Brunswick. In all true buttercups the fruit is a head of several seed-like fruits (*achenes*). The achenes are sometimes found in commercial grass seed.

CRESS OR MUSTARD FAMILY

All members of this important family are herbs with a watery juice, alternate leaves and regular flowers which have 4 sepals and 4 petals each. The petals are arranged in the form of a cross, giving rise to the name of the family, Cress, from Latin *cruz*, a cross. There are six stamens (2 short and 4 long), and the fruit is a rounded,

2-celled pod. The family contains many troublesome weeds ; but many species are well-known articles of food, such as the cabbage, turnip, and radish. The different species of mustard are members of this family. **Wild Mustard, or Charlock**, an annual introduced from Europe, is now common in the Eastern Provinces. It has erect, branching stems, 1-3 ft. high, rough with stiff hairs, deeply-notched leaves, bright-yellow flowers about $\frac{2}{3}$ in. wide, and knotty seed-pods, 1-2 in. long, which are tipped with long beaks. The dull-black seeds have great vitality, and have been known to germinate after lying in the ground for over twenty years. Wild Mustard is particularly troublesome on a light soil, and is too common in our grain fields. When there are a few plants, hand-pulling is the best method of eradication. When fields are overrun with it, spraying with Blue Vitriol (Bluestone), or cultivating thoroughly after the harvest, will keep the weed in check.

Wormseed Mustard is a native species which is spreading quite rapidly. The flowers are yellow, very small, and inconspicuous. The plant is easily distinguished by the pods, which are long, somewhat 4-angled, and borne on little stalks which come out from the stem obliquely, the pod being erect and nearly parallel to the stem. The very small, reddish, smooth seeds are carried by birds and implements, and are found as an impurity in imported seed.

Black Mustard springs from waste places along roadsides, and borders dry fields, but is not common. It has a tall stem with long, spreading branches, pale-yellow flowers, and smooth, erect, square pods about $\frac{1}{2}$ in. long.

Bird Rape has stem, leaves and pods perfectly smooth and waxy like a cabbage leaf. The upper leaves clasp the stem by an ear-like base, and the long pods are on spreading flower-stalks.

Hedge Mustard is an unattractive plant with deeply-cut leaves, minute yellow flowers, and needle-shaped pods which lie close to the stem. It is common in waste places and along streets.

Wild Radish is a troublesome weed about Fredericton. It is the stock from which our Garden Radish has been raised. Wild Radish somewhat resembles Wild Mustard, but the flowers are fewer and larger, paler yellow in color, turning white when old, and plainly veined. The pods are deeply indented between the seeds, resembling a necklace. The root is fleshy, and the stem erect, 1-2 ft. high, branching, and rough, with irregularly-lobed leaves.

Another member of the Cress family common in this Province is **Shepherd's Purse**, easily distinguished by its clusters of small, white flowers and the flat, triangular pods, supposed to resemble the purse of a shepherd of ancient days. The pod has a dividing partition forming two cells, each of which contains 10-12 seeds. Shepherd's Purse is an introduced annual which readily succumbs to cultivation; and since the weed spreads only by seed, every effort should be made to prevent its seeding.

Peppergrass, of which there are several species, is a native annual, sometimes common in grain fields, especially after a wet spring. It is distinguished by its small white flowers, and its oval or circular pods, each with a small notched wing.

Pennycress, a great pest in Manitoba, but not common in New Brunswick, has arrow-shaped, clasping stem-leaves, small white flowers on spreading flower-stalks, and round, flat, winged pods about $\frac{1}{2}$ in. broad. The plant has a peculiar odor resembling that of garlic. When it is eaten by milch cows a disagreeable flavor is imparted to the milk. The seeds have a very pungent taste.

ST. JOHN'S-WORT FAMILY

Common St. John's-Wort is a perennial found in pastures and waste places. It has a strong, tough root, with runners produced at the base of the stem. The stem is erect, 1-2 ft. high, much branched and tough, bearing opposite, narrow leaves marked with transparent dots. The flowers are deep-yellow in color, $\frac{1}{2}$ in. in width, and arranged in leafy, flat-topped clusters. **Small St. John's-Wort** has smaller yellow flowers and purplish 1-celled pods. It is common in low grounds.

PINK FAMILY

Several beautiful garden plants and some troublesome weeds are members of the Pink family. All are herbs with opposite, entire leaves, stems swollen at the joints and regular flowers of four or more parts.

Sticky Cockle, or Night-flowering Catchfly, is an erect plant, 1-2 ft. high, with very sticky stem and leaves. The flowers are white or pinkish, about 1 in. across, solitary or few on a stem, and they open only at night. Sticky Cockle is an introduced annual, sometimes abundant in clover fields and gardens. It is a rank grower and a heavy seeder, but is easily destroyed by ordinary methods of weed extermination.

Another member of the Pink family, **Bladder Campion**, a perennial with creeping rootstocks, is a bad weed in some sections, chiefly in meadows and waste places. The stem is erect, pale, smooth, and branching from the base. The flower is $\frac{1}{2}$ in. wide, with white petals, purple-veined and much inflated. Garden Catchfly, which has pink flowers, is a closely related species.

Purple Cockle, or Corn Cockle, is an introduced annual, found wherever wheat is cultivated. In some sections it is

a pernicious weed. It may be recognized by the reddish-purple flowers, the calyx of which has long lobes three or four times the length of the corolla. The stem is 1-2 ft. high, and clothed with long, soft, whitish-green hairs. The seeds are black, rough, and about the size of grains of wheat. The husks of the seeds often appear as black specks in flour, which is damaged thereby. The seeds are injurious to young chickens. An old English writer says: "What hurt it doth among corne (wheat), the spoyle into bread, as well in color, taste and unwholesomeness, is better known than desired."

White Cockle, or Evening Lychnis, has a viscid-hairy stem, and white or pinkish flowers, opening in the evening. It is not common in this province.

Bouncing Bet is a garden plant, sometimes found running wild by roadsides. It is a smooth herb, with large, rose-colored flowers, which are very pretty when double. The juice forms with water a lather, which was once used as a substitute for soap.

Common Chickweed, with its soft, brittle, prostrate stem, light-green, ovate leaves, and very small white flowers, is extremely common in damp ground, in gardens, and on lawns. It is a fine example of an insignificant plant conquering in the struggle for life. **Mouse-ear Chickweed**, common in gardens and fields, is a perennial, with a prostrate, spreading, hairy, sticky stem, small white flowers, and opposite hairy leaves, which resemble in shape and appearance a mouse's ear. A closely related species, **Field Chickweed**, a beautiful plant found on rocky hillsides and in pastures, has a hairy, slender, ascending stem about 6 in. high, narrow leaves and white flowers in few-flowered, terminal clusters.

Common Spurrey, the last member of the Pink family worthy of mention as a weed, is one not at all attractive in

appearance. It grows rapidly, and has a serious smothering effect on all crops. It is a pestilent weed in gardens and grain fields. The stem is erect or prostrate, and the leaves, 1-2 in. long, thread-like and in whorls at the swollen nodes of the stem. The flowers are small and white. It is an introduced annual, best got rid of by preparing a fine seed-bed, in which the seeds germinate, and then destroying the young plants by harrowing.

PURSLANE FAMILY

Common Purslane is a garden weed, easily recognized by its red, prostrate, fleshy stems and leaves, and its small, yellow, sessile flowers, which open only in sunny mornings. It is a pestilent weed in many gardens. Owing to its tenacity of life and its power of ripening seeds long after it has been rooted up, the plant is not easily got rid of. Constant cultivation is the remedy. Purslane has been used for feeding hogs, but the labor of gathering it is great.

MALLOW FAMILY

The **Mallows** are not noxious weeds. **Round-leaved Mallow** has a stout tap-root, prostrate stem, long-petioled leaves, which are nearly round, and pinkish or whitish solitary flowers, the petals of which are twice as long as the sepals. It is an introduced plant, now common along roadsides and in waste places about buildings. **High Mallow**, which has an erect stem 2 ft. high, sharply 5-7 lobed leaves, and flowers with purple petals three times as long as the sepals, sometimes escapes from gardens.

PULSE OR PEA FAMILY

The members of this family can be recognized by the irregular, butterfly-shaped corolla as seen in the Sweet Pea.

The fruit is a pod containing several seeds. The family is well-represented in Canada, and contains many useful plants, such as peas, beans, and clovers. All plants of the family serve a very useful purpose in collecting, by means of bacteria in the nodules on the roots, nitrogen from the air and soil.

White Sweet Clover, found along roadsides, in fields, and in waste places, is well known. The leaves become very fragrant in drying, and are said to serve as flavoring for snuff and smoking tobacco. They are sometimes packed with furs to protect them from moths.

Yellow Sweet Clover, or **Yellow Melilot**, is also common. It was formerly called in England "King's Clover," because, as Parkinson writes, "The yellowe flowers doe crown the top of the stalks."

The **Wild Tare**, or **Common Vetch**, is an introduced annual weed, not easily eradicated because it ripens its seeds so early. The plant has a simple, hairy stem, leaves with 10-14 somewhat linear leaflets, and large rose-colored flowers. The flowers are nearly sessile in the leaf axils, and usually are in groups of two. The pods are black when mature, and contain from 4-10 round, mottled, black seeds. **Purple-tufted Vetch** has several purplish flowers arranged in a 1-sided cluster, leaves with many narrow leaflets, and light-brown pods, each 1-2 in. long. Purple-tufted Vetch is a persistent perennial, difficult to eradicate. For vetches, a short rotation in which clover is included will be found useful.

ROSE FAMILY

The Rose family contains many species, the majority of which are ornamental plants. A few are agricultural pests. All members of the family have regular flowers containing many stamens, and alternate leaves with stipules.

The pink spires of **Steeple-bush**, or **Hardhack**, a pretty, woolly, dwarf shrub, 2-3 ft. high, lend beauty to the autumn landscape. The leaves are short-petioled, ovate, thick, toothed, smooth above and downy beneath. It invades pastures, and must be pulled out by the roots. Closely related to Hardhack, and blossoming with it, **Common Meadow-sweet** lifts its feathery spires upward from river banks and low meadows. Unlike its pink sister it has a smooth stem and leaves, and its flowers are white or flesh-colored. The flowers have no fragrance, as the name suggests. The name is from Anglo-Saxon *mead-wort*, which means honey-wine herb, alluding to the fact that its flowers, mixed with mead, give it the flavor of the Greek wines.

Silverweed, a perennial with slender creeping stems, compound leaves consisting of from 3-10 leaflets, silvery-hairy beneath, and golden-yellow flowers nearly an inch across, is found along shores and sometimes in wet land. Because of its bright yellow flowers, the term "Golden-weed" would seem more appropriate than Silverweed. It is only when the leaves are placed in water, with the under side up, that we reconcile ourselves to the established title.

From spring to nearly midsummer the roadsides and fields are carpeted with the bright yellow flowers of **Common Cinquefoil**, or **Five-finger**, a slender, prostrate, trailing plant, with leaves of five leaflets, as the name implies. **Rough Cinquefoil**, a weedy-looking plant common in dry soil, has a stout, rough stem from 1-2 ft. high, leaves of three leaflets, and yellow flowers in close leafy clusters. In woodland and meadow one may find many representatives of the Rose family, a group which includes our luscious Strawberry and Raspberry, and many plants with non-edible fruits. Among the latter is **Shrubby Cinquefoil**,

an erect, shrubby perennial, common on the rocky margins of rivers and lakes. Its many branches are crowded with silky, hairy leaves, each divided into 5-7 leaflets. The flowers look like yellow strawberry blossoms.

Common Agrimony is recognized by its round, funnel-shaped bur which clings to whatever touches it. The leaves are divided into several coarsely-toothed leaflets, and the flowers are small and yellow. Throughout late autumn the slender yellow flower-clusters of Agrimony skirt the woods and border the roadsides. In former times the plant was held in high esteem by the town physician and country doctor alike. Emerson longed to know

"Only the herbs and simples of the wood,
Rue, cinquefoil, gill, vervain, and agrimony."

The plant yields a yellow dye; and in France it has been used in making a dressing for shoe-leather.

The bright yellow flowers of **Yellow Avens** are conspicuous in moist meadows during the summer, finally giving way to burs or balls of achenes with many hooked bristles—unwelcome companions on our walks.

ORPINE FAMILY

The Orpine family contains few species, but they are of wide distribution. The common **Orpine**, or **Live-for-ever**, escaped from cultivation in nearly all the older settlements of Canada, is a troublesome weed in pastures, hay fields, and along garden fences. Its thick, fleshy stems have great vitality, and will give rise to new shoots even when picked and placed in a plant press. The flowers are purplish, and are arranged in flat-topped clusters at the end of the erect, stout stem. To eradicate it, spud, break the sod, and cultivate.

EVENING-PRIMROSE FAMILY

There are few weeds belonging to this family, and many beautiful flowering plants, such as fuchsias and clarkias. The **Common Evening-Primrose** is common everywhere in damp meadows, waste places, and along fences. It is a nocturnal beauty, opening its large yellow flowers and emitting the sweet perfume only as evening approaches. During the day the flowers may look faded and dull. Though each flower is attractive only for a night, yet during that time it has many visitors. Moths sip the sweet nectar secreted at the bottom of the long calyx-tube, and at the same time receive a shower of pollen, which is carried to the stigma of another flower. Later in the season the corolla remains longer on the calyx, and we may see the flowers open during the day. The **Small Evening-Primrose** is common in dry fields and by roadsides. It has a low, smooth stem, less than 1 ft. high, club-shaped, 4-angled pods, and pale-yellow flowers which open when the sun is shining.

Fireweed, or Great Willowherb, which sometimes grows 6 ft. high, has scattered, willow-like leaves, very showy purplish flowers in loose terminal clusters, and long, narrow, curving pods filled with many downy-tufted seeds. It is found in fields, especially on ground recently burnt over. It is a tall and beautiful plant, and its loose spikes of magenta flowers lend beauty to waste and desolate fields. In the newly opened flowers the stigmas are closed, and the style turned backwards and downwards, but in the older blossoms the style projects, and the stigmas are expanded to receive the pollen which bees have carried from newly opened flowers. **Glandular Willowherb**, a biennial 1-3 ft. high, has a somewhat sticky stem, nearly sessile leaves, and very small purplish flowers in an erect cluster.

PARSLEY FAMILY

This large family contains many herbaceous plants with unattractive flowers. Some are important as food plants, for example, Carrot, Parsnip, and Celery. The seeds of some members, as in Caraway, are aromatic and wholesome; others, for example, Poison Hemlock and Cowbane, contain rank poisons. The leaves of most species are quite attractive, being repeatedly sub-divided and feathery. A characteristic of the family is the umbel, or umbrella-like cluster of flowers seen in the Carrot or Parsnip. There are few farm weeds members of the family.

Caraway is a biennial running wild in most places. If the plants are mowed closely, or fed off for two successive years, they disappear. Caraway was brought to this country from Europe many years ago, and cultivated for the caraway seed, the oblong, highly aromatic fruit. In former days every farmhouse had its bunches of caraway hanging from the kitchen beams, and even now sometimes the seeds are used for flavoring cakes.

Our **Common Carrot** occasionally runs wild, and is found in fields, pastures and on roadsides. In the wild species the root is comparatively thin and woody. The carrot is an excellent example of the possibility of rapid modification of plants by special selection and cultivation.

Spotted Cowbane, Water Hemlock, or Musquash Root, has a fleshy root, which is deadly poisonous. The stem is stout, smooth, streaked with purple, but seldom spotted, and 2-6 ft. high. The leaves, consisting of many narrow, coarsely-toothed leaflets, are arranged alternately. The small white flowers are arranged in umbrella-shaped clusters about 4 in. wide. The fruit is aromatic when bruised. The roots are very poisonous to stock, especially to cattle, which pull them out and eat them freely when grazing in

the spring time. The roots not only look like small parsnips, but, like them, have a strong aromatic odor. Hay containing Spotted Cowbane should not be fed. The plant is closely related to the Poison Hemlock, the juice of which was used in putting to death criminals and philosophers in ancient Athens.

LOBELIA FAMILY

In summer we see in dry meadows, pastures, and grain fields, the pale-blue flowers of *Lobelia*, or *Indian Tobacco*; and later we see the inflated pods. The stem is erect, leafy, branching, 8-18 in. high, and has a milky, acrid juice. The corolla is pale-blue, $\frac{1}{4}$ in. long, and irregular. The leaves are ovate or oblong, alternate, and toothed. *Indian Tobacco* is somewhat poisonous if taken internally, and it yields a quack medicine of some notoriety. The Indians smoked its dried leaves, which impart to the tongue a peculiar tobacco-like sensation. Another lobelia, the *Cardinal Flower*, a tall perennial with large, intensely red flowers, is found in low grounds in New Brunswick.

HEATH FAMILY

Sheep Laurel, or *Lambkill*, a member of the Heath family, is common, often covering large areas in boggy or rocky fields with its beautiful purple flowers. It was named for Peter Kalm, a pupil of Linnaeus, who travelled in America over 150 years ago. The roots are woody, the stem shrubby, and 1-4 ft. high; the leaves flat, shining, evergreen, and pale beneath, and the showy, rose-purple flowers arranged in lateral, many-flowered clusters. The fruit is a globular pod. *Lambkill* is said to be very poisonous to sheep, horses or cattle, while deer eat its leaves with impunity. The flower of *Lambkill* was a



LAMB'S QUARTERS.



RED-ROOT PIGWEED.



WILD BUCKWHEAT.



LADY'S THUMB.



CURLED DOCK.



SHEEP SORREL.



DAISY FLEABANE.



PEARLY EVERLASTING.



RAG WEED.



BEGGAR TICKS.



YARROW.



CHAMOMILE.

fa
18
wi
in
m
op

fo
ar
an
pc
sn
at
M
ve
by
lon
th
ste
Th
is

it
do
pin
of
br
soi
sp

favorite with Thoreau. In his journal, on June 13th, 1852, he wrote: "Lambkill is out. I remember with what delight I used to discover this flower in dewy mornings. All things in this world must be seen with the morning dew on them,—must be seen with youthful, early-opened, hopeful eyes."

DOGBANE FAMILY

Spreading Dogbane is an erect, shrubby plant, 1-2 ft. high, found in old fields and along roads and fences. The leaves are opposite, ovate, entire and petioled, the flowers small and pink, in loose clusters, and the fruit two long, slender pods, each about 3 in. long. The pods contain many small, silky-tufted seeds. Spreading Dogbane is more attractive in form and more delicate in coloring than Meadow-sweet. The flowers are beautiful, the deep pink veining of the corolla suggesting nectar, which is secreted by glands at the base of the petals. The two or more long, slender seed-pods are conspicuous. One writer says that a thread similar to hemp can be obtained from the stems, cotton from the pods, and sugar from the blossoms. The common name arose from the belief that the plant is poisonous to dogs.

MILKWEED FAMILY

Common Milkweed, so named from the milky juice which it secretes, has a tall (2-3 ft.), stout, downy stem, large, downy, pale, opposite or whorled leaves, and dull purplish-pink flowers clustered at the summit and along the sides of the stem. The fruit is a large, boat-shaped pod, full of brown, flat, silky-tufted seeds. Milkweed is found in rich soil in fields and on the borders of thickets. The young sprouts are said to make an excellent pot-herb; the silky

tufts of the seeds have been used for stuffing pillows and mattresses, and paper has been manufactured from the stout stalks. The milky juice which fills the stem possibly protects the flowers from the inroads of ants, which, in crawling up the stem, cut the delicate surface with their feet, causing the juice to flow. The flower is constructed so as to bring about cross-fertilization through the agency of insects.

CONVOLVULUS OR MORNING GLORY FAMILY

The members of this family are easily recognized by their twining stems and trumpet-shaped flowers, as seen in the **Morning Glory**.

Field Bindweed has creeping rootstocks, tough, curling stems, which wind around the stems of various plants, interfering with their growth, and somewhat arrow-shaped leaves. The flower is white or rose-colored, and solitary. It is a weed not easily eradicated, and careless cultivation only increases the trouble by carrying portions of the rootstock from place to place. The plant may be kept in check by the frequent introduction of well-cared-for hoe-crops into the rotation. Salting is also recommended. The **Wild Morning Glory**, or **Bindweed**, which has large, white, solitary flowers, 2 in. across, on long, slender stalks, is found in moist alluvial soil, and about waste heaps.

Clover Dodder, **Devil's Gut**, or **Strangle Weed**, has a slender, yellowish or reddish stem, twining around clover or grass, and whitish flowers in dense clusters along the stem. There are no leaves and no root after the plant has obtained a hold on another plant. Dodder is a parasite, drawing its nourishment from the juices of the plant to which it clings. There are several species of dodder, parasitic on flax, onions, and a variety of herbs and small shrubs.



MUGWORT.



KNAP WEED.



CHICORY.



ORANGE HAWKWEED.



CANADA THISTLE.



BULL THISTLE.



PERENNIAL SOWTHISTLE.



FALL DANDELION.



BARNYARD GRASS.



GREEN FOX TAIL.



COUCH.



RAG WORT.

FIGWORT FAMILY

To the Figwort family belongs **Common Mullein**, a tall, stout plant, growing from 3-5 ft. high. The leaves are oblong and woolly, and the flowers yellow, in a long, dense, terminal spike. Common Mullein was brought to this country from Europe by the early colonists. The Romans dipped the long, dry stalk in suet and used it as a funeral torch; and the Greeks used the leaves for lamp-wicks. In these days "mullein tea" is greatly esteemed by those who believe in it as a remedy for the lung complaints of man and beast alike. The plant is common in our pastures and on roadsides. To eradicate it, spud or cut below the crown, dig up roots when young, or break up the sod and cultivate.

Toad-flax, or Butter and Eggs, has many linear, entire, sessile leaves, and orange-yellow flowers in terminal clusters. The fruit is a many-seeded pod, opening by a hole found below the summit of each cell. The seeds are small and black. Toad-flax is naturalized wherever there are settlements, and is found by roadsides, near gardens, and in fence corners. The bright blossoms, with their orange and yellow petals, enliven waste places, yet they attract little notice. The plant has been utilized by country people in making what was considered a valuable skin lotion. The juice, mingled with milk, makes a fly poison.

The **Speedwells**, of which there are several common species, are found in damp cultivated fields, and in pastures. The **Neckweed, or Purslane Speedwell**, has a smooth, erect stem, 4-9 in. high, oval or oblong toothed leaves, and small blue flowers. The **Common Speedwell**, "the little Speedwell's darling blue," is noticeable during June and July, when clusters of its tiny flowers brighten the roadside banks. It has a prostrate, rooting stem,

downy, toothed, short-stemmed leaves, and pale-blue flowers growing in thick clusters.

Yellow Rattle, or Rattleweed, is a slender, upright weed, 6-12 in. high, with opposite, narrow, coarsely-toothed leaves set close to the stem, and yellow flowers arranged in a 1-sided leafy-bracted spike. In fruit the calyx is much inflated. The plant prefers damp pastures, but is found everywhere, and is quite common in some sections of the Province.

VERVAIN FAMILY

Blue Vervain, or Simpler's Joy, is common along roadsides, in pastures, and in summer fallows. It is an erect plant, 2-3 ft. high, with a rough, somewhat 4-sided stem, numerous, opposite, narrow leaves, and small purplish flowers in slender, erect spikes. Each flower in fruit produces four nutlets. In early times Vervain was beset with classic associations. Pliny wrote that no plant was more honored among Romans than the sacred Verbena. In modern times it has been regarded as an "herb of grace," supposed to possess special virtues, and to avert disaster if worn on the person.

"Hallowed be thou, Vervain,
As thou growest on the ground;
For in the Mount of Calvary,
There thou was first found."

The name, **Simpler's Joy,** was given it because of the remuneration which the popular plant brought to the "Simplers," as the gatherers of medicinal herbs were called.

MINT FAMILY

This large family contains several weeds, some of which are of common occurrence, but none noxious. The noticeable general characters of the family are the square stem,

strong scent when bruised, opposite, simple leaves, and irregular flowers, usually clustered in the axils of the leaves. The fruit consists of seed-like nutlets, or achenes, which are often found in commercial seeds.

Heal-all, or Self-heal, is abundant everywhere. It is a low, erect plant, 4-8 in. high, with a spike of 3-flowered, axillary clusters of violet flowers, seen in damp meadows and by roadsides after the grass is removed. The common names refer to its reputed medicinal virtues. In former times it was considered a sure cure for quinsy; and the plant was applied to the wounds received by rustic laborers. An old French proverb says: "No one wants a surgeon who keeps Prunelle (Heal-all)."

Canada Wild Mint has a strong, aromatic odor, and purplish flowers clustered in the axils of the leaves. It is a native mint, found in damp meadows and low places. **Whorled Mint**, introduced from Europe and escaped from gardens in some sections, closely resembles Canada Mint. In **Spearmint** the flowers are in a narrow, terminal spike, and the leaves are sessile. **Peppermint** is also a garden escape. It has opposite, strongly aromatic, sharply-toothed leaves, with a distinct taste, and small whitish or purplish flowers in leafless spikes.

Common Motherwort and Catnip are two herbs which should be familiar to all. They, with Tansy and others, are old-fashioned, time-honored plants, which cling persistently to the skirts of the old homestead in whose domestic economy they once played such an important part. **Motherwort** has a tall, erect, square stem, opposite, lobed leaves, and regular axillary whorls of closely clustered, pale-purplish flowers. **Catnip** has a soft, downy stem, heart-shaped leaves with rounded teeth, and whitish flowers crowded in terminal clusters. It blossoms in late summer. Its leaves are readily eaten by cats.

Ground Ivy has a creeping stem, small kidney-shaped leaves with rounded teeth, and bluish-purple flowers loosely clustered in the axils of leaves. It grows along fences and among stones. At one time it was highly prized for medicinal purposes. Gerarde said, "Boiled in mutton-broth, it helpeth weake and acheing backs."

Common Hempnettle, the last member of the Mint family to be mentioned, is an emigrant from Europe, now a troublesome weed in waste places and in all crops on rich land. It is very common about barns. The stem is bristly-hairy, 1-3 ft. high, branching, swollen below the joints, the leaves opposite and coarsely toothed, and the flowers purplish, arranged in whorls in the axils of the leaves. Frequent cultivation will eradicate it.

PLANTAIN FAMILY

In Canada this family includes a few species of weedy, stemless plants, with conspicuous, slender spikes of very small flowers. The seeds, borne in little thin capsules, are found in grass and clover seed. **Common Plantain** has a naked scape, terminated by a long, slender, dense spike of flowers, and ovate or slightly heart-shaped, 5-7 ribbed, radical leaves. The plant is common in moist soils, in meadows, pastures, and lawns. It can be killed by spudding, or by cultivation.

Narrow-leaved Plantain, or Rib-grass, is a deep-rooting perennial with long, 2-12 in., narrow, 3-5 ribbed leaves, and small flowers in thick, dense, short spikes. The yellow anthers of the stamens project from the flowers, giving a yellowish appearance to the whole spike. Later the head elongates, forming a black spike 1-4 in. long. Rib-grass is considered a bad weed, especially when it appears on lawns. The chief injury done by it lies in the

presence of the brownish seeds among those of grasses and clovers grown for sale. The plant itself is palatable to stock, and provides fodder of fair quality. Infested meadows should be ploughed and sown with clean seed. From lawns both plantains may be removed by a sharp knife, run round deeply, close to the crown, thus removing the plant.

GOOSEFOOT FAMILY

This family contains many weedy plants which are enemies of the farmer. One species, **Lamb's Quarters**, is an abundant annual weed in cultivated grounds, in waste places, and near barns. Late cultivation is necessary to combat the weed, as it flowers and seeds until late in the autumn. Land should be ploughed or harrowed immediately after the harvest, and cultivated at intervals until late in the season. The plant has an upright, grooved, much-branched stem, 1-3 ft. high, ovate, serrate leaves, whitish-green below and dark-green above, and minute green flowers in dense clusters. The fruit is a black, shining achene, nearly circular in outline. **Lamb's Quarters** is usually called "Pigweed" by the farmer.

Orache, often found growing with **Lamb's Quarters**, somewhat resembles the latter, but is distinguished by its flat, nearly triangular, fruiting bracts, and its broadly triangular, irregularly-toothed leaves.

AMARANTH FAMILY

Red-root Pigweed, or **Green Amaranth**, is an erect, stout, much-branched, tall plant, with a long, stout, pink root. The leaves are coarse, ovate, wavy-margined, and long-petioled, and the minute green flowers are arranged in short, clustered spikes. **Red-root Pigweed** is a coarse, unattractive annual which draws heavily on the food and

water supply of the soil. Infested land should be frequently cultivated during the fall, and then ribbed-up for a hoe-crop the following spring.

White Pigweed, or Tumbleweed, is a prostrate or ascending annual sometimes found on waste heaps near towns, and along railways. The stems are whitish, and the greenish flowers are in close axillary clusters. When mature, these plants break off at the ground and are blown long distances by the wind, scattering their seeds as they roll along.

BUCKWHEAT FAMILY

The objectionable members of this family belong to two groups, the Docks and the Smartweeds, or Knotweeds. The flowers have no true corolla, the achenes being surrounded by a more or less persistent calyx. The achenes are 3-4-angled or winged.

Doorweed, Knotgrass or Goosegrass, is an introduced species with some native forms. It is very common around dwellings, and in grain and other crops. The stem is prostrate and spreading, the leaves very small, narrow and sessile, and the minute pink flowers arranged in axillary clusters along the stem.

Lady's Thumb, distinguished by the dark blotch in the middle of the leaf, is an ascending, nearly smooth plant, 12-18 in. high, with alternate leaves, hairy leaf-sheaths and small, pinkish flowers in erect, dense spikes. The fruit is a flat, 3-angled, black nutlet. The plant is very common in waste places around dwellings, and on low land.

Common Smartweed resembles Lady's Thumb, but is distinguished from the latter by its pungent, acrid juice, and the absence of the dark blotch in the leaf. The flowers are greenish-white, and arranged in short, nodding

spikes. Smartweed is common in ditches and in damp places everywhere. Several closely related species of smartweed and knotweed are common in New Brunswick in addition to those already described.

Wild Buckwheat, or Black Bindweed, a twining or climbing plant, with heart-shaped leaves, very small whitish flowers in loose clusters, and a dark-brown triangular fruit, is common in grain fields, gardens, and waste places, where it often covers many square feet of surface, choking and smothering useful plants. It somewhat resembles Cultivated Buckwheat, and is often confused with the more objectionable Small Bindweed.

Arrow-leaved Tear-thumb, common in low grounds and ditches, is a climbing plant with a 4-angled stem, the angles of which are beset with reflexed, minute prickles by which the plant is enabled to climb. The leaves are arrow-shaped and clasping. When drawn through the hand the prickles tear the flesh, hence the common name.

Curled, or Sour Dock, is a deep-rooted perennial introduced from Europe, and now common around buildings and in pastures. It has a strongly-developed, fleshy tap-root, a slender stem, 1-3 ft. high, alternate leaves 6-12 in. long with wavy margins, and whorls of small green flowers in long clusters. The fruit is a brown, shining, triangular grain. The Docks are among the few plants whose roots have the power of producing adventitious buds. When cut up, each piece of dock root is capable of sending forth a shoot, thus producing a new plant. Cutting below the crown, which will destroy most biennials or perennials, will not kill Sour Dock. The plants must be pulled up and completely removed, or the roots ploughed up and the pieces carefully collected and taken off the land. It is difficult to separate the seeds from Red Clover seed; but every effort should be made to secure clean seed.

Bitter Dock is not so common. Its lowest leaves are oblong-heart-shaped, and only slightly wavy-margined, the upper leaves are narrow and acute, and all pale green, and the small green flowers are in distinct, loose whorls. The seed-valves bear conspicuous, single, white grains.

Sheep Sorrel, or Sour Weed, is very common in sandy soils, and in worn-out pastures or meadows. The presence of Sheep Sorrel points to poor land. It prefers acid soils. Infested land should receive liberal dressings of manures and lime which counteracts the acidity of the soil. The plant is recognized by its spear-shaped leaves, well-known sour taste, and the small greenish or reddish flowers arranged in clusters.

COMPOSITE OR SUNFLOWER FAMILY

The Sunflower family is the largest family of flowering plants, containing thousands of species, and ranks highest in the plant kingdom. Not only are many of our beautiful garden plants, such as asters, members of this family; but it also includes many plants which are classed as noxious weeds. The flowers are in heads, that is, many small flowers (*florets*) are arranged on a somewhat flat receptacle. In some cases there are two kinds of florets in a head, outer ones with long strap-shaped corollas, called ray flowers, and inner disk flowers, each with a tubular corolla. The Common Sunflower is a good example of this group.

In others all the florets are alike, as in the Dandelion. The calyx when present is closely united with the ovary, and in fruit shows a ring of bristles, teeth, or scales, called a pappus, by which the fruit is carried long distances by winds. The true seed is enclosed in a dry, hard covering. Among leading representatives of the family are the

Asters, Goldenrods, Thistles, Burdock, Fleabanes and Sunflowers. In August we see the tall, striking members of this family crowding thickets and hedges, and bordering roadsides everywhere. The margin of the highway in May is flat compared with its aspect in late summer and early autumn.

Boneset, or Thoroughwort, is recognized by the opposite, perforated leaves, which enclose the stem, and taper to a point, and the small, dull-white, unattractive flowers arranged in terminal clusters. The plant grows from 2-4 ft. high, and is coarse and hairy. It is a bitter herb with medicinal properties. The Indians first discovered its virtues, and called it Ague-weed. The name, Boneset, was given it because at one time it was used in curing a disease called break-bone fever. To the children of fifty years ago the dried herb served as a gruesome warning against wet feet or any exposure which might result in a cold. If such calamity befell the unhappy child a nauseous drink, called "boneset tea," was poured down his throat.

Joe Pye Weed is a tall relation of Boneset, with dull, pinkish flowers in flat-topped clusters, very rough and veiny leaves, and a simple, stout stem growing from 2-12 ft. high. It is an aspiring plant, and its large pink flower clusters tinge with "crushed strawberry" the lowlands through which we pass in autumn days. The plant was named after Joe Pye, a New England Indian, who cured typhus fever with the herb.

Among the common shorter weeds of roadside and fields are the **Fleabanes**, so named because of the belief that when burned they were objectionable to insects. Fleabanes resemble small asters, and are white or slightly tinged with purple. **Canada Fleabane, or Horsetweed**, is a tall, erect, hairy plant, with downy, linear leaves and numerous

small heads of white flowers. It is very common in fields. The **Daisy Fleabane** common in fields and waste places, is tall, branched above, roughish with spreading hairs, and having ovate or lance-shaped leaves, with the lower ones coarsely toothed. The rays of the flowers are short and often tinged with purple. The seeds are carried in hay. **Rough Daisy Fleabane** has rough, entire leaves and white flowers in heads $\frac{1}{2}$ in. across. **Rosy Fleabane** has clasping, entire leaves and rose pink showy flowers in heads $\frac{3}{4}$ in. wide. It is common in low, grassy places.

Pearly Everlasting is an attractive plant. It grows from 1-2 ft. high, and the white, downy stem is leafy to the top with narrow, downy leaves. The flowers are pearly-white and arranged in terminal clusters which lend beauty to the autumn landscape.

Plantain-leaved Everlasting is a leafy, prostrate plant giving off runners. The flowers are silvery-white, and are arranged in small crowded clusters. They are seen only in early summer. The plant is found on dry knolls and slopes, and in pastures. In the autumn all one can see of it is the small rosette of downy, cottony leaves.

Low Cudweed is smaller than Pearly Everlasting. It has an ascending white-woolly stem, 4-8 in. high, narrow, cottony leaves, and whitish or yellowish flowers. The leafy clusters of flowers are inconspicuous. Low Cudweed is an insignificant weed, found in fields and pastures. The name, meaning "lock of wool," is derived from the Greek. **Scented Everlasting** has yellowish-white flowers in terminal clusters, and a leafy stem. The whole plant is fragrant.

Ragweed, or Hogweed, is a bad weed in rich, cultivated land. It was introduced into this Province in imported seeds, and is now spreading fast. The classical name means "food for the gods," a name perhaps sarcastically

given to this weed. The plant is much branched, 1-3 ft. high, slightly hairy, with finely divided leaves, and unattractive yellowish flowers in spikes. The seeds have a bad taste, and they impart a peculiar odor to the milk of cows eating the plant. This weed may be kept in check by mowing to prevent seeding, and by cultivating stubble land. An average plant produces 5,000 seeds. The **Great Ragweed**, not common in New Brunswick, sometimes grows to a height of 12 feet.

Cocklebur is a stout, rough, low branching plant, 1-2 ft. high, with opposite, triangular, 3-lobed leaves and green flowers in heads. The striking feature of the plant is the bur with the spines at the top. It is a coarse weed found around barnyards and in waste, manured ground. The burs become entangled in the wool of sheep, causing the wool-picker much trouble.

Another familiar wayside plant, a tramp long since arrived from Europe, is **Elecampane**. It has a tall, stout stem, 3-5 ft. high, and mucilaginous roots which have been used as a horse medicine. The leaves are alternate, entire, large, and woolly beneath, with the upper ones clasping. The flowers are in large heads, resembling small sunflower heads. The ray flowers are yellow and numerous, in one row, and the disc flowers greenish-yellow. Elecampane is usually found on damp ground where a road passes a swamp. Its succulent leaf furnishes food for many grasshoppers which, perched on the dry, dusty leaves, help to swell the grand chorus of a mid-summer day's music.

Black-eyed Susan, Cone-flower, or Yellow Daisy, has deep golden, orange-yellow ray flowers in one outer circle, and a central purple-brown cone. The stem, growing 1-2 ft. high, is rough-bristly, and the leaves are alternate, nearly entire, 3-ribbed, and thick. Black-eyed Susan is a native

perennial plant found in old meadows and pastures, and sometimes in grain fields. Mowing usually kills it, but sometimes it is necessary to break up a field and plant a hoe-crop.

Ox-eye Daisy, or **Whiteweed**, locally known as **Bull's-eye**, is a very common and troublesome weed in pastures and hay fields. Its heads are 1-2 inches wide, with white ray flowers and bright yellow disc flowers. The roots are short and thick and of great vitality, the stem 1-2 ft. high, and the leaves cut-toothed, partly clasping, and slightly aromatic. **Ox-eye Daisy**, a native of the Old World, brought to this country by the early colonists, now stars the June meadows with its gold-centred blossoms, which delight the eyes of children and the beauty-lovers, while they make sad the heart of the farmer. It is hurtful to pasture land, and makes hay of poor quality. Its eradication is difficult. Sod must be broken up, and the land cultivated and seeded to clover. The "Wee, modest, crimson-tipped flower" of Burns, and the "day's eye"

"That well by reason men it call may
The Daisie, or else the eye of the day,"

as sung by Chaucer, is not the **Ox-eye Daisy** but the true daisy, *Bellis perennis*, of England.

In low grounds, by a passing brook, and in barnyards or grain fields, one comes in contact with the tenacious 2-pronged fruits of **Beggar-ticks**, or **Pitchforks**, which make one's clothes a means of conveyance to "fresh woods and pastures new." The plant grows from 2-5 ft. high, is much branched, and has leaves with 3-5 divisions, and unattractive flower heads consisting of brownish-yellow, triangular flowers. **Greater Bur-Marigold**, a closely related species found in wet places, has opposite, simple, narrow, toothed leaves, and larger heads. It does its best to

retrieve the family reputation for ugliness, and surrounds its dingy, disc flowers with a circle of showy golden rays which make the moist ditches of late autumn attractive.

Yarrow, or Milfoil, has soft, feathery, much-divided leaves, and flat-topped clusters of small white flowers. It is a European plant named by Linnæus, the great botanist, after Achilles, the great Grecian hero, who cured the wounds of his soldiers with the plant. It abounds in meadows and pastures, but may be eradicated by careful cultivation. The early English botanists called the plant "nose-bleed," because "the leaves being put into the nose caused it to bleed." One writer said, "Most men say that the leaves chewed, and especially greene are a remedie for the tooth-ache." In Sweden the plant was used in the manufacture of beer; and Linnæus considered the beer thus brewed to be more intoxicating than that in which hops were used.

Common Tansy has a stout root, an erect stem, 2-4 ft. high, deep-green, much-divided leaves, and a flat-topped cluster, 2-3 in. wide, of many heads of deep orange-yellow flowers. The juice is strong-scented and acrid. Tansy is a perennial usually found in patches by roadsides and in lanes near dwellings. Tansy means "undying," because the flowers are durable. The plant has been used in medicine since the Middle Ages; and even in these days "tansy tea" is held in high repute by country people.

Mayweed, or Chamomile, is another strong-scented herb very abundant by roadsides, along the streets of towns and in waste places. The white-rayed heads closely resemble those of Ox-eye Daisy, but they are smaller, and the centres are yellow, in high relief. The leaves are finely-cut and possess a strong, disagreeable odor, by which the plant is easily recognized. Chamomile tea, considered by some a cure for many ills, is made from the leaves which, when rubbed on the flesh, will cause blisters.

Common Wormwood is another European herb, found in old gardens and by roadsides, which is much esteemed for its medicinal properties. It is a strong-scented, silky-hoary plant, 2-4 ft. high, with a somewhat woody stem, much-divided leaves, and nodding flower heads.

Mugwort, so common by roadsides and in old fields near dwellings, is a tall, rank, unsightly plant closely related to Wormwood. The stem is erect, 1-4 ft. high, and branching, the leaves are deeply cut, green and smooth above, and cottony-white below. The unattractive flowers are arranged in clusters of small heads

Burdock is a well-known, coarse biennial, common in pastures, dooryards and waste ground. It has very long stout roots, hence its eradication is difficult. If cut below the crown with a spud once or oftener, it will not long survive. The hooked burs cling to everything, and do much damage to the wool of sheep. When burned the plant yields a strongly alkaline ash; and a decoction from the roots is said to equal the juice of Sarsaparilla as a blood purifier.

Common Groundsel is a low, nearly smooth, branching annual, with alternate, divided, clasping leaves, and yellow flowers in terminal flat-topped clusters. It is found in gardens and cultivated fields, chiefly on low grounds. The plant flowers for several months of the year, and heads in all stages of development can usually be found on one plant.

Ragwort is a pernicious weed, not widely distributed in New Brunswick, but found along the railways. It is quite common about Chatham and Newcastle. The plant somewhat resembles Tansy, but the leaves are softer and the flowers a lighter yellow in color. It is a short-lived perennial brought to this country from the British Isles. Cattle eating the green plant sicken and die, but sheep are

not injuriously affected. Every effort should be made to eradicate the plant. If not common it may be pulled out or spudded. If a field is badly infested, a short rotation should be adopted.

Knapweed, or Hardheads, is a stout, rough plant, 1-2 ft. high, with entire, narrow leaves rough with hairs, and terminal, round, hard, black heads of purplish flowers. Knapweed is a European plant now naturalized in meadows and pastures, and by roadsides at several places in New Brunswick. Spudding, mowing several times to prevent seeding, or careful cultivation, should keep it from spreading.

Chicory, or Wild Succory, is a tall, branching, slightly hairy plant, with a deep tap-root, partly clasping leaves with irregular edges, and numerous conspicuous bright-blue flowers $1\frac{1}{2}$ in. wide, on the naked branches. It is an introduced perennial, found in old fields and on roadsides. The long tap-root makes its eradication difficult; but spudding and frequent cultivation will do much to rid the land of it. The root, when dried and ground, is used for adulterating coffee. Horace mentioned the leaves of Chicory as part of his frugal fare; and Pliny remarked on the importance of the plant to the Egyptians, who used it in great quantities. It is extensively cultivated in France, where the leaves are used in a salad.

“ Oh, not in Ladies' gardens,
 My peasant poesy !
 Smile thy dear blue eyes,
 Nor only—nearer to the skies—
 In upland pastures, dim and sweet,—
 But by the dusty road
 Where tired feet
 Toil to and fro ;
 Where flaunting sin
 May see thy heavenly hue,
 Or weary sorrow look from thee
 Toward a more tender blue.”

Wild Lettuce is a tall, smooth, erect plant, 1-7 ft. high, with hollow stem, alternate, deeply-lobed, partly clasping leaves, and yellow flowers in numerous small heads in a long and narrow cluster. It is found in deep, rich soil in fields and by roadsides. There are several closely related species common in this province.

The **Common Dandelion**, with its radical, coarsely-toothed leaves, long tap-root, and hollow, naked stem terminating in a bright yellow head of florets, is well-known. Emerson's definition of a weed was: "A plant whose virtues have not yet been discovered." This does not apply to common Dandelion, because its young sprouts have been used as a pot-herb, its fresh leaves as a salad, and its dried roots as a substitute for coffee. It is said that the Apache Indians so greatly relish the plant as food that they travel great distances to procure it.

The **Tall Dandelion**, or **August Flower**, which blossoms in the autumn, has a branching solid stem, and smaller heads of yellow flowers. It is common in pastures and by roadsides.

The **Hawkweeds** are noxious weeds. The **Orange Hawkweed**, or **Devil's Paint Brush**, is a persistent perennial introduced into New Brunswick from Western Canada. It is a vigorous grower, throwing out many creeping branches close to the ground, and with its thick foliage crowding out grasses in pastures and meadows. It is erect, 6-12 in. high, hairy with stiff hairs, and has thickly-clustered, rough, radical leaves, and deep-yellow or orange flowers in heads about $\frac{1}{2}$ in. wide, forming terminal clusters. On land used for crops it is destroyed by cultivation with hoe-crops; and in pastures salt, broadcasted at the rate of $1\frac{1}{2}$ tons per acre, will destroy the weed and not injure the grass. In England, Devil's Paint Brush is called "Grimm the Collier," on account of its black hairs. **Branching**



INDIAN TOBACCO.



SPREADING DOGBANE.



MILK WEED.



FIELD BINDWEED.



MULLEIN.



BUTTER AND EGGS.



YELLOW RATTLE.



HEAL-ALL.



GROUND IVY.



MOTHERWORT.



HEMP NETTLE.



COMMON PLANTAIN.

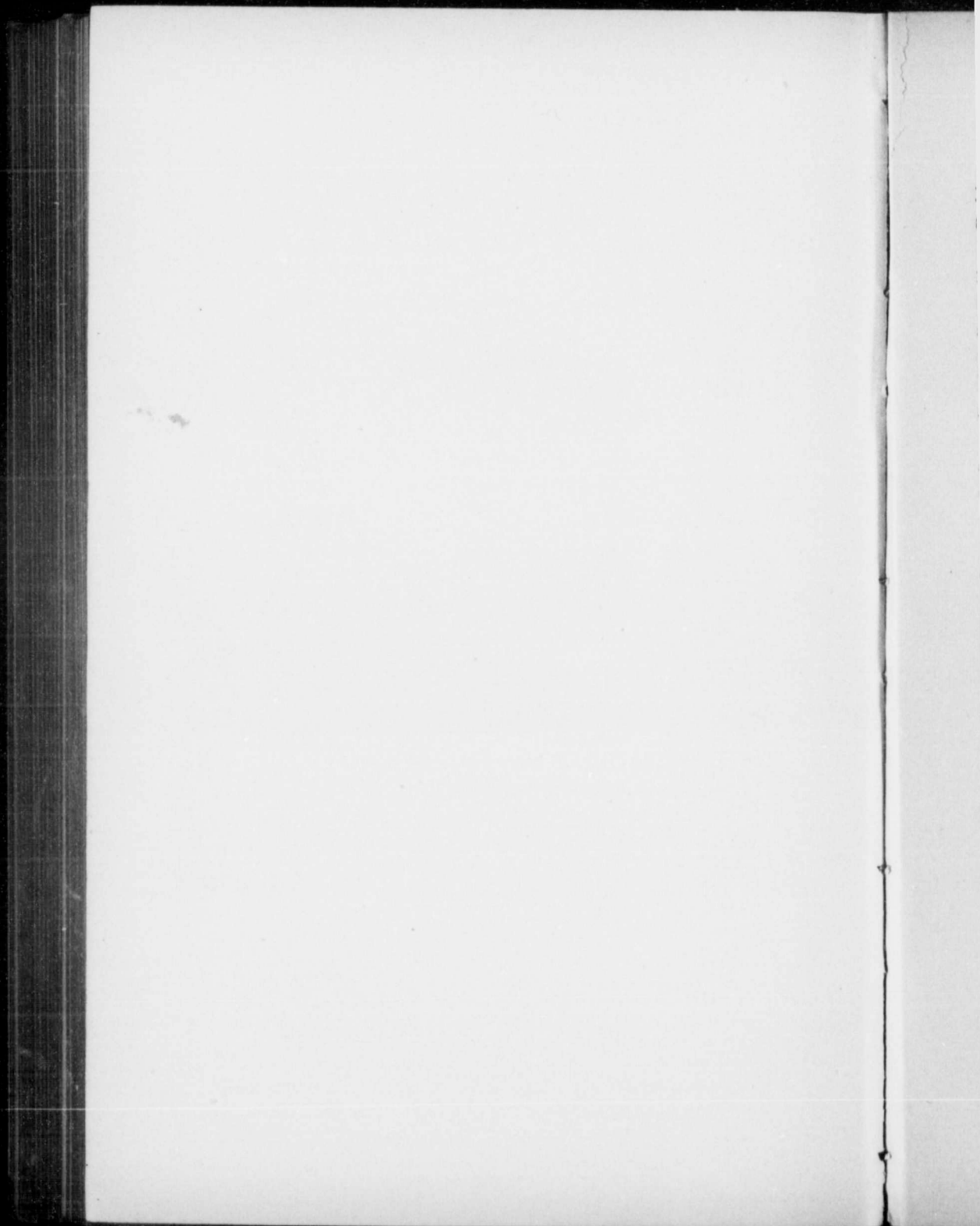

Hawkweed, or Yellow Devil, is a terrible weed in some sections of New Brunswick. It resembles Devil's Paint Brush, but has longer and narrower leaves, and more numerous and smaller pale-yellow flowers. It is usually much branched, and the lower branches raise their flowers as high as those of the upper branches. Yellow Devil may be a yellow-flowered variety of Devil's Paint Brush. Frequent cultivation, or salt, as for Orange Hawkweed, are suggested methods of eradication. **Rough Hawkweed**, which has small heads, a stout, leafy, rough-hairy stem, and flower stem densely clothed with dark bristles, is a common weed in sandy or rocky ground.

Canada, or Creeping Thistle, with its tough, numerous underground stems, prickly-lobed leaves, and small heads of lilac-purple flowers, is very common and well known. It is a hardy perennial introduced from Europe. Perhaps this plant is, among weeds, our greatest pest. Care should be taken to prevent its seeding by mowing the plants before the seeds ripen. Careful and persistent spudding, after-harvest cultivation of stubble-land, a short rotation with frequent hoe-crops and a copious use of clover in seeding down, will keep it under control.

Common, or Bull Thistle, often by mistake called Scotch Thistle, is a coarse, widely branching introduced perennial, with large, deep-purple flower heads about 2 in. across. It is not so common nor such a vile weed as Creeping Thistle. The real **Scotch Thistle** which has a flat, round, prickly head about 1 in. wide, is sometimes found in waste grounds.

Several **Sow-thistles** are bad weeds. **Perennial Sow-thistle** has large, vigorous rootstocks full of milky juice, erect stem 3-4 ft. high, soft, deeply-cut, slightly spiny leaves, and yellow heads of flowers, at the top of nearly leafless stems. The plant is troublesome in some sections.

It is a heavy feeder and draws much food and moisture from the soil. Mowing to prevent seeding, hand-pulling after a rain, and thorough cultivation, are recommended. The **Annual Sow-thistle** has smaller, pale-yellow flowers, and is not so troublesome. It is found in cultivated fields and about buildings. The plants should be pulled from grain crops. **Spiny-leaved Sow-thistle** is an annual with clasping leaves with rounded, prickly lobes, quite common in gardens and in waste places.

