

Technical and Bibliographic Notes / Notes techniques et bibliographiques

The Institute has attempted to obtain the best original copy available for scanning. Features of this copy which may be bibliographically unique, which may alter any of the images in the reproduction, or which may significantly change the usual method of scanning are checked below.

L'Institut a numérisé le meilleur exemplaire qu'il lui a été possible de se procurer. Les détails de cet exemplaire qui sont peut-être uniques du point de vue bibliographique, qui peuvent modifier une image reproduite, ou qui peuvent exiger une modification dans la méthode normale de numérisation sont indiqués ci-dessous.

- | | | | |
|-------------------------------------|---|-------------------------------------|---|
| <input type="checkbox"/> | Coloured covers /
Couverture de couleur | <input type="checkbox"/> | Coloured pages / Pages de couleur |
| <input type="checkbox"/> | Covers damaged /
Couverture endommagée | <input type="checkbox"/> | Pages damaged / Pages endommagées |
| <input type="checkbox"/> | Covers restored and/or laminated /
Couverture restaurée et/ou pelliculée | <input type="checkbox"/> | Pages restored and/or laminated /
Pages restaurées et/ou pelliculées |
| <input type="checkbox"/> | Cover title missing /
Le titre de couverture manque | <input checked="" type="checkbox"/> | Pages discoloured, stained or foxed/
Pages décolorées, tachetées ou piquées |
| <input type="checkbox"/> | Coloured maps /
Cartes géographiques en couleur | <input type="checkbox"/> | Pages detached / Pages détachées |
| <input type="checkbox"/> | Coloured ink (i.e. other than blue or black) /
Encre de couleur (i.e. autre que bleue ou noire) | <input checked="" type="checkbox"/> | Showthrough / Transparence |
| <input type="checkbox"/> | Coloured plates and/or illustrations /
Planches et/ou illustrations en couleur | <input checked="" type="checkbox"/> | Quality of print varies /
Qualité inégale de l'impression |
| <input checked="" type="checkbox"/> | Bound with other material /
Relié avec d'autres documents | <input type="checkbox"/> | Includes supplementary materials /
Comprend du matériel supplémentaire |
| <input type="checkbox"/> | Only edition available /
Seule édition disponible | <input type="checkbox"/> | Blank leaves added during restorations may
appear within the text. Whenever possible, these
have been omitted from scanning / Il se peut que
certaines pages blanches ajoutées lors d'une
restauration apparaissent dans le texte, mais,
lorsque cela était possible, ces pages n'ont pas
été numérisées. |
| <input checked="" type="checkbox"/> | Tight binding may cause shadows or distortion
along interior margin / La reliure serrée peut
causer de l'ombre ou de la distorsion le long de la
marge intérieure. | | |
| <input checked="" type="checkbox"/> | Additional comments /
Commentaires supplémentaires: | | Continuous pagination. |

SCIENTIFIC CANADIAN

MECHANICS' MAGAZINE

AND
PATENT OFFICE RECORD

Vol. 9.

OCTOBER, 1881.

No. 10:

NOTE AND COMMENT.

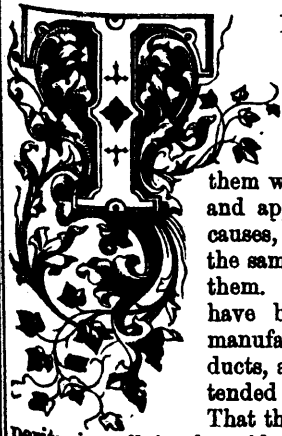

HIS has been a month of exhibitions, one following closely on the heels of another. The material prosperity of the country has been emphasized by two facts in relation to them widely differing in themselves, and apparently pointing to different causes, but, in reality, both requiring the same inference to be drawn from them. The exhibitions, as a rule, have been poorly filled as regards manufactures and other home products, and they have been largely attended by spectators of all classes. That the latter is an evidence of prosper-

ity is sufficiently evident. A large attendance on the exhibition grounds means a certain amount of money in the hands of the farmers and others, and a willingness to spend it, born of the prosperous times. But curiously enough the generable prosperity is answerable no less for the general poverty of the exhibits. The fact of the matter is that manufacturers throughout the country are booking orders more rapidly than they can fill them, and many have found an absolute impossibility at once to keep pace with their custom and spend time in preparing an exhibit. We have heard even of several cases in which would-be exhibitors were compelled by rush of business to deliver to customers the goods prepared for exhibition. This was particularly the case in Halifax, where in consequence the Machinery Hall was almost empty, and the whole show suffered from the over goodness of the times.

Much the same story is told in Montreal and Toronto, although not visible perhaps to the same extent. The agricultural side was probably the best here, and did real credit to the exhibitors. But the industrial exhibits were not on the whole up to what we had a right to expect, and the mechanical department was really nowhere. Of machinery, the only objects worthy of special notice were the silk weaving machine, of Mr. Corriveau, and the exhibit of the Electric Light Company, both of which attracted, and worthily, a great deal of attention from the public. On the whole, however, the Montreal Ex-

hibition of 1881, was a decided advance upon that of last year, as it was undoubtedly far better attended. Much good may and ought to come out of these exhibitions if only they are approached in the right spirit on both sides. They ought to be a useful school for the mechanics of the country, and it is to this use of them that we invite the Committees of future industrial fairs to turn their attention. There are many ways in which such an exhibit as ought to occupy the machinery hall might be utilized even during the brief space of an exhibition, and the mechanic who goes even to an indifferent exhibition with his eyes open may carry away much that will help him in his work. All that is required is a little systematization, perhaps a descriptive catalogue, certainly an endeavor to get together an exhibit that shall be at once a credit to the exhibitors and a real benefit to the visitors and this has hardly been done as yet.

M. NAUDIN, the well-known author of so many beautiful works on hybrid plants, urges the culture of fruit trees in pots either as a pleasure or a source of profit. Plants fed by the delicate extremities of their roots called spongiols or hairs; now the more of these root hairs a plant possesses the more energetic will be its growth. When being transplanted into the pot, the main roots ought to be shortened; this will induce fasciules to be formed and stop the development of the pivot-root. Pot culture hastens the fructification of young trees and augments their fertility, more it enables new varieties to be produced by crossings as isolation is more favored. The hint is one which will be of great value to arboriculture generally, and which professional fruit growers in particular should not fail to profit by.

THE official announcement has been made of the appointment of a Royal Commission in England "to inquire into the instruction of the industrial classes of certain foreign countries in technical and other subjects, for the purpose of comparison with that of the corresponding classes in this country, and into the influence of such instruction on manufacturing and other industries at home and abroad." The Commissioners appointed are— Mr. R. Samuelson, M.P., Professor Roscoe, Mr. P. Magnus, Mr. J. Slagg, M.P., Mr. T. Smith, and Mr. W. Woodhall, M.P., all excellent gentlemen in their way, but scarcely

likely of themselves to do much towards advancing technical education, except of the professional kind. There is not a single name among them that has been prominently identified with the cause of technical education in England of the sort required by the industrial classes. If further instruction in technological subjects is to be given in the curriculum of the school or university, the persons named would be just the men to suggest the proper course. But what is wanted is a thoroughly practical system of instruction for artisans, and this is precisely what the members of the Commission cannot suggest, because they cannot, or do not understand their requirements. Not long since one of the leading educationists of the old country, a great advocate of technical schools, and one who has devoted much time and thought to the subject, brought from various continental school specimens of the joinery work used as models in those schools, and specimens of several kinds made by the students. In reality these samples would not have been accepted by a jerry-builder in this country, not even for a five or six-roomed cottage. Yet the professor thought them excellent. And why? Simply because he was not himself acquainted with the technical details of the joiners handicraft. If any good is to come out of these Royal Commissions, practical men must be appointed on them, or they will result in absolute failure.

THE Belgian Congress devoted to the study of school-hygiene concludes that every pupil ought to have at least 32 square inches of superficial space; the classes ought not to be numerous; the water closets to face the south; plant trees in the play ground, and secure there for each pupil a space equal to six square yards, and $1\frac{1}{2}$ yards space under the shed: the pupils ought not to remain longer than one hour at a time in class without some bodily recreation; each child ought to have 10 to 20 cubic yards of air, and the latter to be renewed twice or thrice daily; the stores should be placed near the external walls; the window stool ought to be higher than the heads of the pupils, so that the light can fall on them at an angle of 45° .

It would be well if school authorities in other countries realized that these things need careful study, and demand imperatively the carrying out of the results of that study. It is nothing to fill the mind with knowledge if we injure the body in so doing, and learning is ill purchased at the cost of health. School-hygiene is a science which has been neglected until almost recently, and which to-day is but imperfectly understood in many cases, but its importance cannot be overrated, and the observance of its dicta needs to be constantly insisted on.

DESIGN PATENTS ON MACHINERY.

When a builder of machinery originates and applies some useful device, he generally secures it by a patent, but when he studies out and puts into metal or wood some useful forms in a machine, exclusive of device, he hardly ever thinks of applying for a patent on the "design." But a stove manufacturer who has planned and brought into existence some new style of range or heater, generally applies for a design patent at once, as a matter of regular business. Custom of the trade seems to govern the actions of original thinkers and experimenters in either case. Recently, however, the binding force of patents for designs has been brought to the attention of many machinery manufacturers who had hardly given the subject a passing thought before.

In at least one or two late instances apparent (and unconscious) infringers of design patents on certain machines have settled by paying money to the patentees, rather than devote the time and

expense required for a legal contest. Such a development has, as might be expected, awakened unusual interest in this class of patents, among machinery manufacturers, and has set a few of them to tracing up the origin or the antiquity of certain forms and combinations used by them and claimed by other individuals as protected by design patents. As nearly all of our readers well know, it is a difficult matter to originate absolutely new and meritorious styles of ordinary shop tools, yet the possibilities for combinations are ample. The useful features of some of these combinations which figure as the basis of design patents are, to say the least, very questionable. Although patents for designs are as binding during their existence as those for inventions, the former appear in the *Official Gazette of the U. S. Patent Office* only by name, while all the latter are described with drawings and claims. Therefore the would-be original designer of a machine is kept in the dark as to what his competitors have secured if they neglect to place their protected product before the public, unless he sends to the Patent Office for a copy of every design patent as fast as they are announced in the weekly issues of the *Gazette*. The conclusion will readily be reached by every intelligent individual whose attention is directed to the matter, that all kinds of patents issued should be described with drawings in the weekly official publication of the Patent Office, in order that the public as well as inventors and designers shall be protected.—*American Machinist*.

EXPIRATION OF THE MCKAY BOOT-SOLE SEWING MACHINE PATENTS.

By the expiration of the McKay patents covering machines for sewing soles upon boots and shoes, on the 15th of August, a new impetus will be given to the shoe business in the States. Heretofore those who used the McKay sole sewing machines were obliged to pay an average royalty of two cents for every pair of shoes made. Estimating the annual product of the shoe manufacturers of the country of late years equal to 50,000,000 pairs, the royalty exacted of them for this machine has been equal to \$1,000,000 a year. The relief from this tax is a substantial gain to the people, and the free use in future of the machine at a comparatively small cost will probably lead to a large expansion of the production.

The McKay machines had their beginning in the invention of Lyman R. Blake of Abington, Mass., in 1858. Prior to that date nearly all sewed boots and shoes had a light thread of the inner sole cut away, the seam being laid therein, after which it was tacked to the last, the edges of the upper drawn over it, a narrow strip of leather called the welt sewed to both inner sole and upper, and to this welt the outer sole was sewed, all of the work being done from the outside. Hand-sewed work is still done in this manner. By Mr. Blake's machine the stitches were taken directly through the insole, by means of a horn or arm working inside the shoe, and also through the edge of the upper and outsole, without the insertion of a welt. But only the coarsest grade of shoes could be manufactured with this machine. Gordon McKay of this city, soon became interested in Blake's invention, and in 1860 induced Blake to take out fresh patents, one covering the machine-made shoe itself, as a new article of manufacture, and the other covering the process of making; both independent of the original patent on the mechanical structure. He then bought up the invention for \$8,000, renamed it the McKay Sole-Sewing Machine, and set about its improvement. He spent large sums of money in this direction, but it was not until two years later that he obtained for \$300 from Mr. Mathias, of Boston, a patent for channeling the leather as in hand-sewing. The inventor, on realizing its importance, soon applied for a larger price, and on being offered one-fifth interest declined it, and accepted in lieu a cash payment of 9,000 dollars. In 1864 Mr. Blake came once more to the help of the proprietor, and devised a means whereby the horn was heated from an alcohol lamp placed inside of it, the radiation of heat causing the wax to soften on the thread as it passed through, and thus making the machine available for sewing shoes of the finest quality. This contrivance was patented jointly by Blake and McKay. The machine, thus improved, was now taken in charge by a company styled the McKay Sole-Sewing Association. The Association continued to devise and perfect, and even to give away machines, to facilitate their introduction, until no less than \$130,000 had been advanced on the enterprise.

All grades of work could now be produced by unskilled as well as skilled hands, and up to 1875 no less than 225,000,000 pairs of shoes had been made in this country on the McKay machine, while its product at this date must be in excess of 500,000,000 pairs. Nine-tenths of all the boots and shoes ma-

manufactured in the United States have of late years paid toll to the McKay Association. Besides this, the machine became speedily popular in Europe, where it is known as the Blake and Goodyear machine."—*Industrial News*.

A LONG SLEEP.

Early in February last, a young man, a stranger, was discovered in what seemed to be profound sleep in the sitting room of a country tavern near Allentown, Pa. He could not be roused, and was sent to the Lehigh County Poorhouse. A small devotional book found in his pocket bore on a fly leaf the name Johann Gyumbere, written in German script. On the opposite page was written "Saros Cometat, Post Raslavidz, Austria." It was inferred that the man was from Saros, a county in Hungary, and that his name was Gyumbere. He has since been known as the sleeping Hungarian, and his long coma or trance has attracted the attention of many physicians as well as much popular interest.

Until April 22nd. he had to be fed with liquid nourishment only. On that morning, the seventy-first day of his sleep, he arose from his bed, dressed himself and sat down on a chair, staring wildly about the room. The attendant placed him in bed again, and went down after his breakfast. On his return, Gyumbere was sitting up in the same chair, looking deathly pale and with his eyes wide open. He was given something, but instead of eating freely, as usual, he seemed to have difficulty in swallowing and ate very little.

He kept his eyes open all day and shewed some signs of intelligence, but could not speak. Later he fell asleep and his attendant left him for a moment. Thereupon Gyumbere rose, locked the door, opened the window, and jumped out, falling twenty-five feet. He was found lying on the ground near a high fence, ten feet or so from the window. He was somewhat bruised, but not seriously hurt. For four days he continued to rise from his cot of his own accord, but never spoke. The physicians of the almhouse reported that during the four days of his wakefulness he was weak and feverish. His eyes were staring but continually open. He acted like one delirious during a fever. On one occasion, when his eyes were held open, Dr. Erdman repeatedly threatened him with clinched fist, and every time he did so the patient laughed. This convinced the physician that he could see. When a flute was played in the room, Dr. Erdman noticed that the patient's feet moved in a manner that suggested dancing.

Hopes were expressed of his speedy recovery, but on April 26th. he relapsed, closed his eyes, and did not open them until May, 20th. when he spoke, a flower having been held to his nose. Six hours after he closed his eyes again and kept them shut until late on the night of July 31st when he was roused by a Poland, who spoke to him in Salvonic. Subsequently he sat up and told his story, which confirms the report published by the *Jeffersonian* of Charlottesville, Va., some months ago, with regard to the victim of a practical joke at that place some time last summer.

His recollections of events show a complete gap between the time of his falling asleep in the tavern and some day about four weeks ago, when he began to realize again that he was living. He knew nothing of his fall from the window, or of an abscess which formed on his head during his sleep. Altogether the case is a curious one, and the report of the conditions and progress of it by Dr. Erdman the almhouse physician, is likely to be of considerable interest.

SCIENCE IN CHINA.—The interest which the Chinese are taking in modern science and culture is not confined to the fact that they are sending great numbers of their young men to England and other countries for a liberal education, for they are also establishing schools of science and literature in their own midst, modeled after those of foreign nations and partly under the conduct of foreigners. They are not only apt as scholars—as imitators—but they are also beginning to strike out as original thinkers. As a case in point, a Chinese physicist, as reported in *Nature*, has recently asserted that "the law, which is commonly accepted, and which states that the octave of any note may be produced by doubling the length of a musical cord or tube, is strictly true only for chords. He says that experiments with tubes of different lengths and diameters have led him to the conclusion that the ratio of length is as 4 to 9, instead of 1 to 2." Several English and American scientific treatises have already been translated and published in the Chinese language, and it is probable that the time is not far distant when we may find valuable original publications in the same language.

Mining, Metallurgy, Mineralogy

THE MILLING OF GOLD QUARTZ.

The following paper was recently read before the California State Geological Society, by Melville Attwood, F. G. S., "On the Milling of Gold Quartz.—Amalgamation.

When last I had the pleasure of addressing you, the subject was on the petrology, or jointed structure of the rock masses of the Bodie mining district. This evening I wish to call your attention to a much more important subject, namely, the milling of "Gold Quartz." At the present time the mining community of this State are using strenuous efforts to make the working of low-grade ores a profitable business, and if any suggestion of mine will in the least assist the matter I shall feel amply repaid.

I hope, however, other miners more capable than myself will communicate the results of their experience on this subject.

If we search the records of past times, we shall find that a great deal has been done years ago, which might be applied with great advantage even at the present time, in proof of which examine the drawings and descriptions of them which I have brought for your inspection. The first, or No. 1, (see engraving) I copied from Sir John Pettus' book on the "Laws of Metals, &c," published in 1683, nearly 200 years ago. You will see how much better it is calculated to wash gold alluvia than our modern rocker.

An explanation of the engraving, taken from the book referred to, is as follows:

1. The man that worketh with the rattar.
2. The middle floor whereon that which goeth through the rattar doth fall.
3. The lower floor whereon that which cometh from the middle floor doth fall.
4. The plain receiver of that which falls upon both.
5. The person that stands on a board and out of a wheelbarrow throws the matter or oar, into the tunnel which guides it into the rattar.
6. The channel in which water doth run into the rattar.

"Then some of the gold washers use upon their hearths the strong timode black and russet woolen cloth, over which they do drive their works, because the woolen is rough and hairy, so that the small and round grains of gold will remain, and not run forth, (as it will from the timode), whereby the gold upon the black cloth may apparently be known, though it be small and little. Others use instead of the timode or black woolen cloths, linsy-woolsy (half linen and half woolen; wrought in the manner as the timode is), upon which the gold doth stick better, and such cloths do last longer, because of the linen that is among the woolen, which doth strengthen it; therefore it is better for this work."

For the concentration of sulphurets look at the drawing No. 2, "Brunton's ore-dressing frame," which I remember seeing in successful operation in the year 1847. The drawings I have copied, were published in the *London Mining Journal*, 1847. It is very similar to the Frue concentrator now being so successfully introduced at our different quartz mills.

A is a piece of prepared canvas, 30 ft long, joined at the ends—thus forming an endless band, with slips of wood fastened transversely on the inside, and making, when stretched on frame and rollers, a surface of 12ft. long and 4ft. wide, the inclination of which is altered to suit the material to be operated on by the screws, *GG*. *B* is an inclined plane, divided into several channels, in connection with the trough, *C*, into which is placed the ore to be dressed, from which it is washed and distributed over the channel, *B*. *D* is a shoot, over which clear water runs; *E* a cistern or receptacle, where the cleaned or dressed ore is deposited; and *F* another, into which the dirt and waste falls. By the action of the water-wheel, the endless belt is made to move continuously upward against the stream; and as the work is washed on the table overhead, *B*, where the stream is increased by the clean water, which two streams combined are sufficient to wash the waste over the end of frame into cistern, *F*, while the ore by its superior gravity, resists the force of the stream and is carried upward, being, while passing between the heads, *B* and *D*, subject to the action of the stream of clean water. When the ore thus separated from the waste is carried up past the head, *D*, it is free from all action of water, and adheres to the canvas until it touches the water in cistern, *E*, when it directly falls off, and is deposited in the bottom of the cistern, *E*. Thus, there is a continuous stream of material to be dressed passing over the inclined plane, *B*—a continuous stream



FIG. 1.—MACHINE FOR WASHING GOLD ALLUVIA 200 YEARS AGO.
THE MINING OF GOLD QUARTZ.

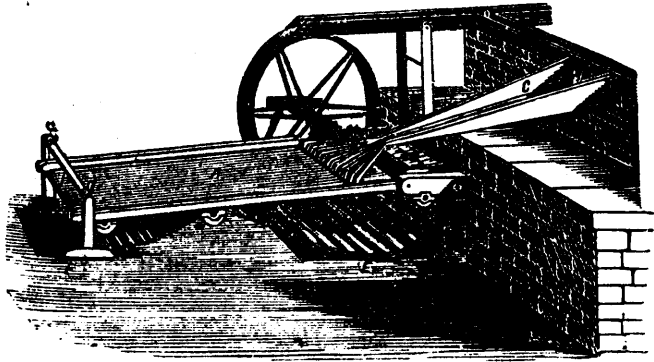

FIG. 2.—BRUNTON'S ORE DRESSING FRAME.



FIG. 4.—MODERN ROCKET.

of waste going over the end of frame into cistern, *F*—and a continuous stream of clean or dressed ore being deposited in cover, *E*, and it is found that no other method yet adopted can produce the same effect, either as regards the high produce of the cleaned ore or the impoverished state of the waste, in which particular point the great saving is—as, let the person attending it be ever so negligent, no ore is being wasted, so long as the water-wheel is at work, while in the old method there is a great quantity of ore which finds its way to the tail of the frame through the negligence of the party using it.

The plan of a "trunking buddle," No. 3, or a machine for washing the slimes or tailings collected in dams or catch-pits, was an invention of my own, by which, in 1842, I recovered many thousand pounds worth of copper ore. It was published in the London *Mining Journal* of that year, and models of it placed in the Museum of Practical Geology. It might be used

to advantage as a rapid means of treating the tailings that have accumulated at the Comstock, Bodie, and other mining districts.

In this engraving, *A* represents the holes by which water is admitted; *B*, knives to cut the tough slime and divide the stream of water; *C* is a drum with wing to work the slime up well; *D*, grates; *E*, besoms to sweep the grates; *F*, vanes to keep stirring up the slime as it passes into the trunks; *G* trunks; *H*, stops to regulate the water in the trunks; *I*, a box into which the besoms sweep the small pieces of wood and stuff too large to pass through the grates.

Fig. 4, is the modern rocker or cradle which is shown simply that it may be compared with the ancient appliance shown in Fig. 1.

The principal object in my now addressing you, however, is to suggest and recommend the extracting of the

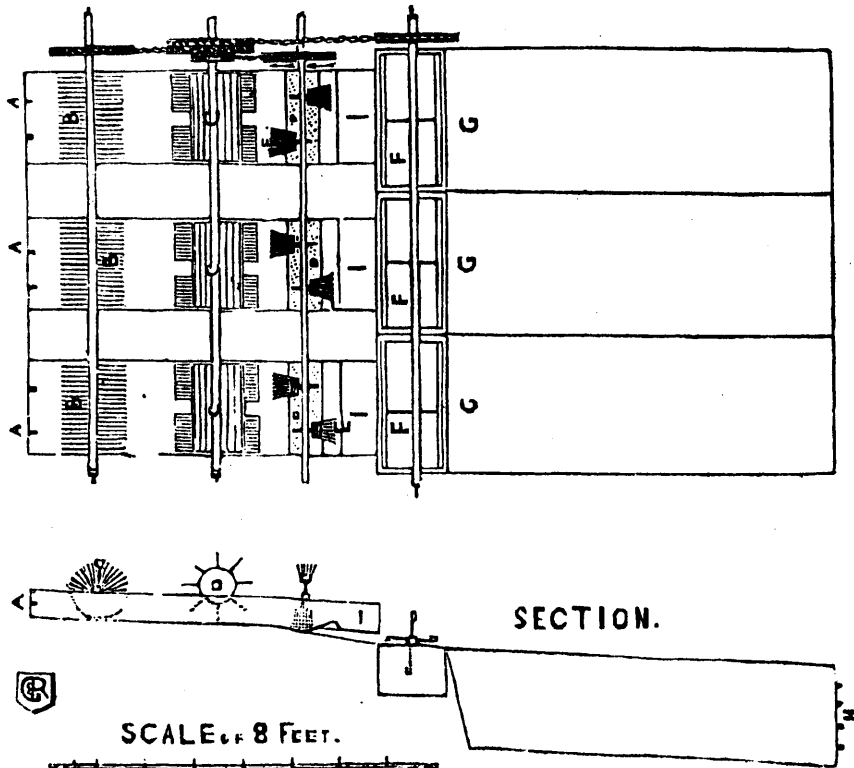

FIG. 3.—ATTWOOD'S MACHINE FOR TRUNKING SLIME.

GOLD FROM THE SULPHURETS

by amalgamation in wooden barrels, the same that has been successfully employed at the St. John del Rey mine, for nearly half a century, in place of the chlorination process now so much used in this state. I feel assured by the former process more gold will be saved, and at a considerably less cost.

The St. John del Rey mine is owned by an English Co., and has been profitably worked for upwards of 45 years. Last year, (1880) in their fiftieth annual report it appears they stamped 63,540 tons of veinstone, and state the cost of milling the same was 3s. 11½d. per ton, about \$1; and that the net profit for that year's workings was \$315,000.

The veinstone of the St. John del Rey mine is a mixture of magnetic, arsenical and common pyrites disseminated in a quartzose gangue, and is composed of about 40 p.c. of silica, and 60 p.c. of pyritic matter—the arsenical pyrites carrying the most gold. The smallest grain of gold is rarely seen before concentration.

THEIR PROCESS OF AMALGAMATION.

is nearly perfect, but the stamping and concentration very defective, the stamps doing but little duty, only 1½ tons per head during the 24 hours. Their plan of concentration being principally what is called "straking," consisting of a number of fixed inclined trays 30 ft. in length and 18 inches wide, with a fall of one inch to the foot; the trays are covered for the first 16 ft. with bullocks skins tanned with the hair on them, and in lengths of two feet two inches; below these are a series of blankets or baize cloths of the same length. The deposit of sulphurets on the first three skins contains nearly all the gold, and amounts to about 0.42 of a cubic ft. per ton of veinstone. Stamped, it contains about 30 ounces of gold per ton, all of which with the exception of one ounce is in a free state, the ounce of gold being mechanically mixed with the coarser grains of pyrites.

It is estimated that in stamping and straking, 10 p.c. of the total amount of the gold is carried off in suspension by the water.

Their loss in amalgamation is comparatively trifling as far as I can gather from their numerous reports, and will average less than 4 p.c.—the loss of mercury is 0.45 ounces per cubic foot of sulphurets amalgamated. The apparatus employed for amalgamation of the sulphurets, consists of wooden barrels, 4 ft. in length, and two feet five inches in diameter, having a capacity of 20 cubic ft. The charge of sulphurets for each barrel is one ton and a half free from decomposition, and 60 lbs of mercury. There is also a sufficient amount of clean water at the same time introduced to give the slimes the necessary degree of fluidity to enable the globules of quicksilver formed to become properly incorporated, without allowing them to become sufficiently mobile to admit of the setting of the mercury and amalgam at the bottom. The barrels when charged are allowed to rotate from 20 to 30 hours, making 18 revolutions per minute in accordance with the state of the atmosphere.

The contents of the barrels are afterwards washed in an apparatus called a "saxe," which is used to separate the gold amalgam from the refuse. In this country it might be perhaps better to employ separators the same as these used in the different pan mills.

In their report of 1880 the results of their trials of the Comstock pan system was anything but satisfactory, indeed in the milling for gold that system appears to be too costly for low-grade ores, and not fit for the rich. It is better calculated for the treatment of veinstone which contains in the ton from five to ten ounces of silver, and that in a suitable mineralized condition as chlorides, etc.

The attempts to grind the sulphurets when they contain upwards of 50 p. c. of pyritic matter, and to amalgamate the mechanically combined gold enclosed in the particles of pyrites, at the same time and in the same pan, has not been attended with success from the earliest attempts, some of which I witnessed in Brazil in 1832, which was then made in an apparatus being a modification of the Hungarian bowl. The St. John del Rey sulphurets when ready for the barrel contain about 95 p. c. pyritic matter, and are reduced so fine that 90 p. c. of it will pass through a sieve having 100 holes to the linear inch.

What I have tried of the Californian Sulphurets the pyritic matter varies from 70 p. c. to 90 p. c., and about 75 p. c. of it will pass through a sieve of 100 holes to the linear inch.

The following analysis was made by John A. Phillips, F.G.S., and published in his Metallurgy of Gold and silver. I lately received a letter from him, wherein he tells me he is going to publish another work on gold:

ANALYSES OF AURIFEROUS CALIFORNIA PYRITES CONCENTRATED FROM TAILINGS BY JOHN A. PHILLIPS,

	from Grass Valley.	from near Sonora.	North Star Grass Valley.
Sulphur.....	46.700	37.250	43.720
Arsenic.....	.310	8.490	1.360
Iron.....	41.650	36.540	39.250
Copper.....	trace.	trace.	.220
Lead.....	trace.	.400	trace.
Gold.....	.037	.302	.026
Silver.....	.036	not	.012
Cobalt.....	.036	determined.	.150
Silicia.....	10.970	17.150	14.230
Totals.....	99.703	100.162	08.968

PER TON OF 20 CWT.

	Oz.	Dwt.	Gr.	Oz.	Dwt.	Gr.	Oz.	Dwt.	Gr.
Gold.....	.12	2	0	.93	13	0	8	10	0
Silver.....	.11	6	0	0	0	0	3	18	0

The condition of most of the gold in California sulphurets is much the same as that met with in the St. John del Rey mines, and if treated in the same way will amalgamate as easily. It only wants to be reduced a little finer. It will be time enough to adopt any of the new processes for the treatment of *rebellious gold ores* when they discover *any other ore* of gold, except telluric gold, which, so far, has only been met with in small quantities. In a pamphlet published by Mr. Kitto on the Gold Fields of Victoria as far back as 1867, Mr. Kitto states that the average

COST OF MINING AND MILLING

of the gold quartz in the Victoria District was under 13 p. c., say, \$3 per ton. Some of the mines were deeper than those in the Bodie district, and the veinstone much harder to stamp, and the gold, unlike that of Bodie, which is mostly free, was mechanically mixed with the pyritic matter, and consequently much more difficult to save. The Port William Co. had, up to 1866, stamped 388,681 tons of veinstone, which yielded gold equal to six tons of 2,000 lbs each. For four weeks' returns, October of that year, the quantity of quartz stamped 4,342 tons, yielding 1,355 oz. 10 dwt. of gold, an average of 6 dwt. 5½ grains per ton—a little more than \$6. The receipts were £5,944 4s. 6d.

The introduction of the Comstock pan system may have caused the shutting down of the Mammoth and many of the Bodie mines which produce low-grade ore. The wet-stamping of rich silver ores is a great mistake, and even in the wet-stamping of low-grade silver ores, unless they contain a large proportion of chlorides, they should be concentrated before amalgamation.

Concentrations on a small scale can be made much closer with the Bates than any other instrument, and consequently it is very useful in checking the working of large machines.

A great deal of useful information may be obtained from "Baron Inigo Boru's" look on "Amalgamation," published in 1791, wherein he describes and illustrates with drawings, the process of "Movable Casks for Cold Amalgamation."

CARELESS WORKING.

A copper miner who understands anything of his business, would be horrified if you were to propose to him to work his mine after the fashion of some of our silver mines; that is, neglect to make a careful assorting of the richer ore when broken underground, and at the grass to mix rich ore with comparatively waste rock and then pass them together through the stamps, taking the chances afterward of whatsoever they may be, to recover the ore by pans, etc. He would tell you how much would be lost and carried away in suspension with the water, and what a large proportion would go to enrich the slime pits.

In the treatment of low-grade silver ores the concentration of the ore after stamping by such a machine as the "Frue concentrator," would, I think, reduce the cost of milling and at the same time save more silver. I take this opportunity to express the pleasure it gave me on visiting

THE STATE MINING BUREAU

To see how well and with what great taste the collection were presented to that institution was arranged and also the satisfaction I felt that the joint labor of so few should have been crowned with success. We must not forget, however, that through the liberality of Mr. John Mackay we were enabled to send the collection to the Paris exhibition of 1878, where it won for this State a gold medal—proving its great value.

In the Mining Bureau it may be said to have formed the nucleus of a collection for industrial purposes which has already grown so rapidly that it is superior to any on this coast, filling

a gap so much needed; indeed at the rate in which donations of minerals, etc., are pouring in, that institution will soon become a place of great resort, and the public will then feel grateful and award to Mr. Joseph Wasson the praise he so justly deserves for the forethought and trouble he has taken to procure for them an institution of such a useful character.

SUBSTITUTES FOR COAL IN THE HOUSEHOLD—THE FUEL OF THE FUTURE.

The introduction of some practical, simple and economical method of providing dwelling houses with ample supplies of heat for warming, cooking and other domestic purposes, as a substitute for the present universal use of coal, is one of the reforms in domestic economy which the near future may have in store for the sorely-tried housekeeper of to-day. The demand for substantial reform in this direction is loud and imperative. The use of solid fuel, in the form of coal for example, in the manner in which we consume it in our stoves, heaters and ranges, is probably as extravagant, wasteful, troublesome, dirty and generally unsatisfactory a method of providing this necessary convenience of the household as could be devised. In addition to the annoyance and expense of having coal hauled from the yards and dumped into our cellars, from which it must be dragged laboriously to every story of the house where it is needed, we must at present suffer the annoyance of knowing that we buy at the outset from 5 to 10 per cent of worthless material in the form of ash, that must afterwards be laboriously gathered up and conveyed to the barrel or box provided for its reception, and that we blow out at our chimneys about three-quarters of the heat that is given off in its combustion. To those who have given the subject any thought, therefore, the designations—wasteful, troublesome and dirty, are not too strong in characterizing the use of coal in the household.

Savants and inventors have long since appreciated the lamentable deficiencies of the present method of supplying heat for the household, and have suggested several plans of reform. These plans, some of which have had measurable success in practice, all proceed upon the principle of supplying the heat from some central source of supply. The methods proposed involve either the use of steam, superheated water or fuel gas. In all these plans, the heating agent is supposed to be generated at some centrally located station, from which it is to be distributed by suitably protected pipes through the streets and into the houses where it is to be consumed.

We mention steam first on the list of substitutes for the use of solid fuel in the household, because of its prominence, on account of its present successful and very general use for the heating and warming of buildings. Thus far, however, its use has been generally confined to the warming of large buildings used for business purposes, and only to a limited extent has it been introduced into private dwellings. The success, however, attained by Mr. Holly, of Lockport, N. Y., in devising and putting into practical operation a system of heating extensive areas—whole towns, in fact—by a system of steam heating, the heating agent being generated at central stations, and from there distributed, has fully demonstrated the practicability of the general adoption of steam for the warming of dwelling houses as an economical substitute for coal. On the score of safety, as the generators are located at a distance, there can be no valid grounds for objection; while on the score of convenience, the use of steam is infinitely superior to coal. In one respect, however, it apparently fails to fully meet our domestic requirements. It cannot, or at least has not yet, been made practicable for cooking purposes. This requirement could probably be met by the construction of suitable ovens for retaining the heating agent, and by the use of steam at sufficiently high temperature. But it must be remembered that many of the operations of the kitchen require so high a temperature that the steam would have to be supplied under enormous pressure, a condition that would materially increase the element of danger in its use, and which would practically render it unsuited for warming, for which steam of moderate pressure is found most suitable. Steam, therefore, does not entirely meet the requirements of a domestic heating agent.

The use of hot water has been suggested for the same purpose, the same purpose, the best known plan of this kind being the Prall system for transmitting heat by means of pipes carrying water superheated up to about 400° to 425° Fah. The water is superheated in boilers located at central sections, and is distributed in the same manner, and with similar precautions against loss of heat by radiation and conduction, as with the steam heating systems. The Prall system, which, we are informed, is about to be tested in practice in New York—its representative having se-

cured the necessary official privileges for the purpose—contemplates the division of the city into a number of districts each of a square mile in area. Each of these will have its central station (with its battery of furnaces, boilers, superheated water tanks and force pumps), where the heat will be generated, stored up in the water, sent through the street mains, and delivered by suitable distributing pipes into every house choosing to receive a connection with the street main. In the house the pipes divide, one set branching into the kitchen for cooking purposes, and another into and through the rest of the house for warming. After making the circuit of the house, the water is returned through a separate line of pipes to the reservoir, thus making a complete circuit.

We have no opportunity as yet of noting the success of this plan, since it has not yet gone into practical operation. We have no desire to anticipate the result, but from what we have learned respecting it, we should incline to the opinion that the use of water under such high pressures as is contemplated, would meet with objection on the score of safety, and might be found troublesome to manage on the scale on which it is designed to operate the system.

The third plan—unquestionably the plan of the future—consists in the production of gaseous fuel, at central stations, and its distribution to and through our houses. The possibilities of fuel gas made a profound impression upon observing and practical men some years ago, when it was demonstrated that water gas, produced by the mutual interaction of steam and carbon at high temperatures, could be made in immense volumes at very trifling cost. The resulting gaseous product of this reaction, consisting substantially of hydrogen and carbonic oxide, furnishes a fuel as nearly perfect as can be imagined. Both ingredients are highly combustible, yielding an intense heating effect when ignited, and the products of combustion are gaseous.

By the adoption of water gas in our houses for cooking and warming, the existing contrivances can be utilized with little alterations, and as much or as little heat as may be required can be turned on at pleasure. When not required, the fire can be extinguished by the simple turning of a stop-cock. It gives complete exemption from the trouble, dirt and wastefulness of coal. Our fires will not need to be kept up over night, Winter and Summer, as they now are, because of the trouble of making them up fresh in the morning. The gas fire can be made in an instant, and extinguished as quickly when it has served its purpose, and its heating effect can be controlled to a nicety for hours at a time. By the admission to the product, at the stations of a trifling percentage of naphtha, or some one of the petroleum products, to give a sensible and penetrating odor like coal gas, so that its leakage may at once be detected by the smell, it will be as safe and as completely under control as the latter.

It is a subject of surprise to us, in view of the perfect adaptability of fuel gas for domestic purposes, that it has not already found its way into general use. We are aware that many difficulties had to be overcome before the manufacture attained its present economical and practical shape; but now that this essential has been successfully accomplished, we look for active measures on the part of the friends and advocates of fuel gas, with a view to its speedy introduction into our towns and cities. It commends itself by every consideration of convenience, comfort and economy, and any serious effort looking to the accomplishment of this reform will be warmly welcomed and seconded by the intelligent public.

Earnock Colliery, near Hamilton, N. B., was last week partially lighted by the Swan electric lamp as a preliminary trial. At present only twenty-two lamps have been connected, of these sixteen are fixed, and the remainder are portable. The fixed lamps are suspended from the roofs or the galleries, and are protected by strong glass globes fitted with reflectors of silvered copper; the portable lamps are attached to long flexible conductors for convenience of shifting; they are inclosed in very strong glass lanterns protected by wire guards. These lamps may be hung at any convenient place, or may be set on the ground. The Earnock Colliery is not a fiery mine, but the lamps, switches, and contact makers are all arranged as if they were to be used where gas was prevalent, everything being made quite air tight so as to make the communication of a spark to the air in the mine quite impossible. Several "shots" were fired without affecting the lights, and to prove the power of the latter photographs of the visitors were taken in the galleries. This seems to open out a new field for the electric light, in which its usefulness can hardly be overestimated. If mines can really be well lighted without danger, a new era will have dawned for the miners which they will not be slow to appreciate.

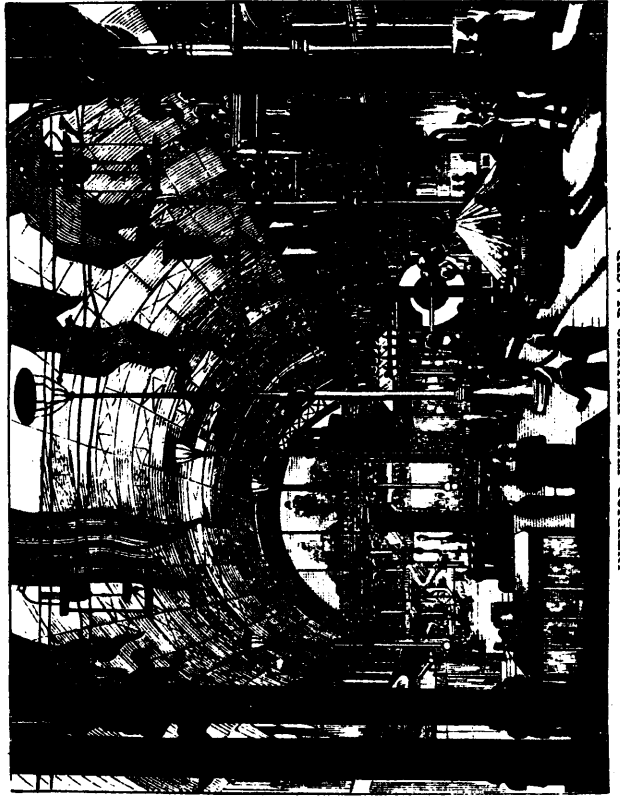
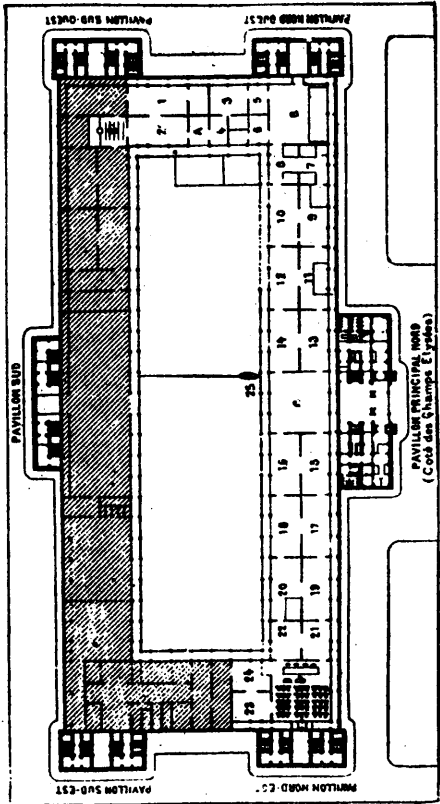

INTERIOR WITH EXHIBITS PLACED.

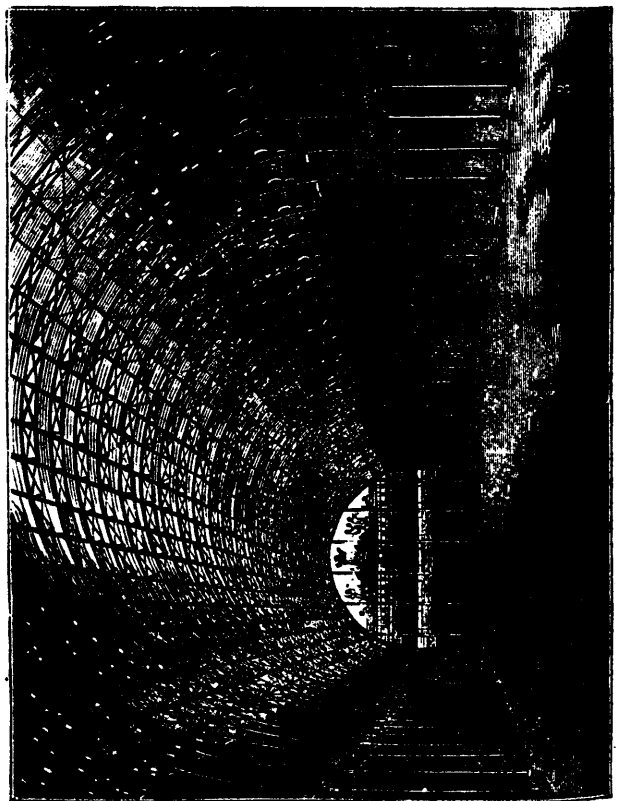
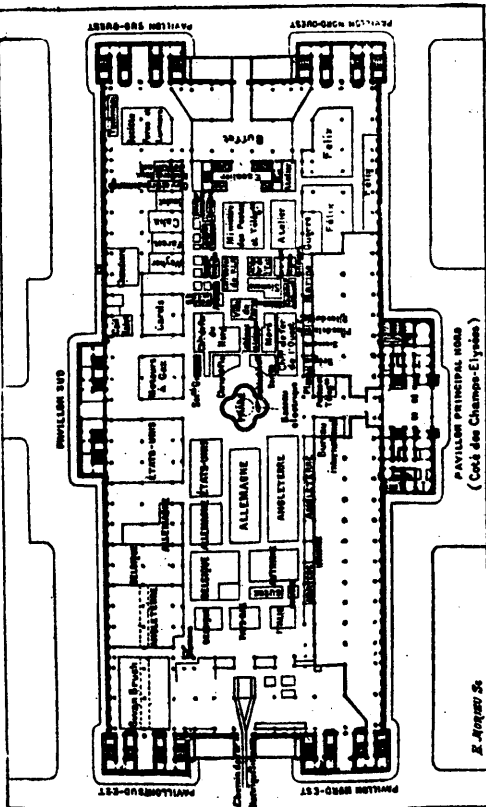

INTERIOR BEFORE EXHIBITION.

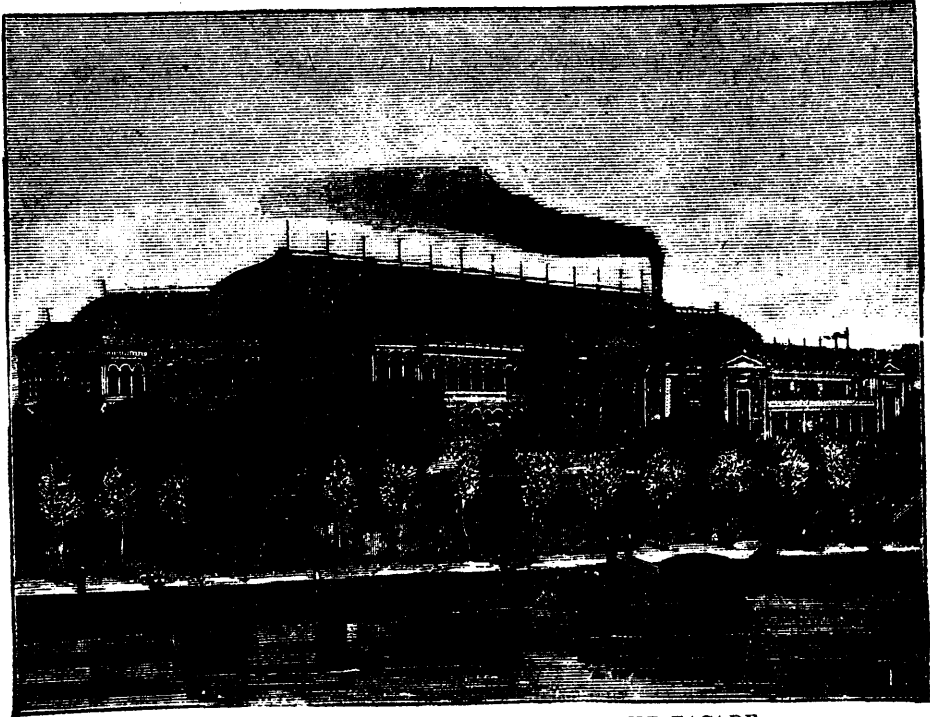

THE PALACE OF INDUSTRY.—RIVER SEINE FAÇADE.

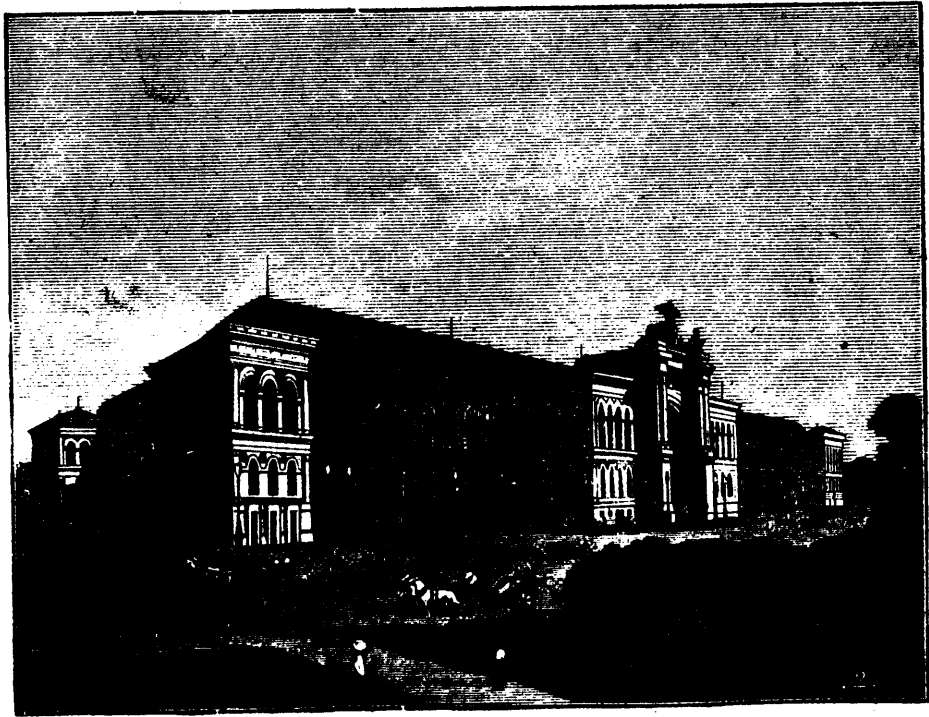

THE PALACE OF INDUSTRY.—CHAMPS-ÉLYSÉES FAÇADE,
THE INTERNATIONAL ELECTRICAL EXHIBITION OF 1881 AT PARIS.

Scientific.

THE ELECTRICAL EXHIBITION AT PARIS.

The engravings on this page present so clearly the plan and surroundings of the International Exhibition of Electricity at Paris that any verbal description would be superfluous. The exhibition, which opened August 11, 1881, is held in the great Palace of Industry originally erected for the World's Fair of 1855. The palace fronts upon the magnificent avenue of the Champs Elysées, in a triangular park between the avenue and the Seine. Views of the Champs Elysées front and the side toward the river are shown in the engravings. The naked interior of the great hall, and the same room when decorated with flags and filled with electrical exhibits, are shown at the bottom of the page. At the top are plans of the ground floor, showing the allotment of space to the several countries exhibiting, and of the galleries divided into apartments for special classes of exhibits, salons, lecture room, and the like.

On entering the palace from the Champs Elysées the splendid array of novel exhibits and brilliant decorations dazzles and confuses the visitor. The numerous pavilions, draped and ornamented with the flags of all nations, the strange machinery, the multitudinous wires, together with the vast proportions of the hall, overpower the sight, and it is not until after the lapse of several minutes that the order and plan of the exhibition are apparent.

In the center of the nave, resting in a great basin of water surrounded by plants, stands a veritable lighthouse. At its base floats the electric boat of Trouvé.

At each side of the entrance to the nave are huge lions, and above is a grand luster of iron work bearing Siemens Lamps. The half of the hall to the right is allotted entirely to France, which has twice as many exhibitors as all the rest of the world. The other half of the hall has been allotted to foreign nations, the principal divisions being assigned to England, Germany, and America. The ten smaller divisions are occupied by Austria, Belgium, Italy, Russia, Sweden, Norway, Spain, Hungary, Switzerland, and the Netherlands. A striking feature of the British section is a handsome pavilion, with a red and white striped canopy, containing the electrical apparatus used by the post-office departments of London. Outside are several large tables on which are arranged the electric inventions and apparatus of the British exhibitors. One of the most conspicuous and popularly attractive exhibits in this section is a full-sized buoy carrying two Siemens lamps. Here also may be seen the great induction coil made by Mr. Appo at the suggestion of Mr. Spottiswood, the eminent electrician. This coil produces a spark forty-two inches long.

The German exhibits are presided over by a bust of Germania, whose domain embraces three large departments. The electric railway of Siemens is outside the building.

The American division is made conspicuous by the triple cluster of flags grouped round the pavilion. In this compartment are established the United States Signal Service exhibits, the Gray electro-acoustic telegraph, including the multiple or harmonic system, the Bell telephone, the interesting telephone of Dolbear, and many others. Considering the distance which everything had to be brought, the American exhibition is a remarkable one, and the Edison department promises to be as interesting as it is extensive.

The Belgic department has a very interesting display of lamps and telephones.

Italy is represented by a beautiful pavilion, which has *Italie* on the one side and *Rome* on the other, in large letters, and which contain, among other things, the historical apparatus of Volta and Galvani.

The Russian department exhibits, among other things, the apparatus of M. M. Latchinoff and Tchikoleff.

The Dutch department has a fine exposition, the principal feature of which is the great electrical machine of Van Marum and his immense Leyden battery.

The Swedish and Norwegian departments promise to be interesting, as does also the Russian, but as yet very little of the machinery is in operation.

Underneath the galleries the great machines and dynamo-electric generators are established. The electric railroad is represented in this part of the building also.

The French pavilions dedicated to the several departments of electricity are very interesting. In one is the "Administration of Telegraph Lines," which shows all the apparatus employed. One pavilion, dedicated to the "City of Paris," shows all the electrical applications which have been put into use there, in-

cluding the time service. Many of the railroad companies are represented by systems for indicating the movements of trains, etc., etc. Here also are wagons having electric brakes, and many other marvelous and interesting inventions.

The beautiful galvanoplastic objects of the well-known firm of Christophe attract much attention. The monumental stairway conducting to the galleries is at the lower end of the hall. A number of lights of different systems surrounding the nave make a brilliant display.

The hall of the saloon will be lighted by the Jablochhoff system; the great saloon of honor by the Maxim; the hall of the comparison of telephones by the Faure accumulator; as also the bath room and kitchen. The experiments of electric photography will be made by the Wilde light, and Edison lamps will illuminate the hall of conference and the adjoining hall.

The balloon of M. Tissandier glides above the heads of the spectators on the ground floor along a wire from one side of the galleries to the other.

The lower galleries to the left are devoted to the motors and magneto-electric machines. The other galleries to the left are dedicated to the accumulators of Planté, to the exhibition of the ministers of marine and of war, and the exhibition of the well-known firm of Breguet.

A FATAL ELECTRIC SHOCK

A strange and terrible accident occurred last evening at the generating rooms of the British Electric Light Company on Ganson street. About 9 o'clock two young men named George Leonard Smith and Henry Kimball, in company with another young man and two girls, stepped into the station and stood looking at the machinery in motion. Smith was very inquisitive and wanted to experiment. The manager, Mr. G. Chaffe allowed him to try a harmless experiment, which consisted in taking hold of one of the brushes attached to the commutator, in which the electricity is held until carried away over the wires, and then, taking hold of the hands of his companions, a gentle current of electricity was passed through their bodies. Smith wanted to take hold of two of the brushes, but Mr. Chaffe grabbed his arm and held him back, telling him it was sure death to touch them. The party shortly afterwards left, Mr. Chaffe telling them to get out. About a quarter past ten o'clock Smith suddenly came into the building, seemingly under the influence of liquor. He leaned over the railing which keeps outsiders at a distance from the machinery, and before a warning word could be said he had grabbed the first and third brushes. Mr. Chaffe saw what he was about to do and made a jump for him. His hand stuck fast to the brushes, and, giving the engineer the word to stop the engine, he took hold of Smith and endeavoured to pull him from his hold. This he was unable to do, but as soon as the engine stopped, Smith raised himself to his feet, and, throwing up his arms, gave a loud gasp and expired instantly.

The thing was done so quickly that those who witnessed it could scarcely believe their eyes. Smith's face had a pale bluish tint and was drawn out of shape. His hands were badly burned, and on several of the fingers the flesh was burned to the bone. Of the unfortunate man but little could be learned, save that he was formerly a scooper at the Wheeler elevator, but for the past week had been handling lumber in various yards on the island. He was about twenty-eight years of age, and in the neighborhood of five feet eight inches in height. It was stated that he has a wife and child living in the city, but where, the writer was unable to ascertain. Mr. Chaffe says the generator is one of tremendous power, and would kill fifty thousand men as easily as one.—*Buffalo Courier August 8.*

A COMPACT BATTERY.

The desiderata in a galvanic battery may be briefly stated as compactness and ability to produce a strong and constant current of electricity, cheaply and without eliminating poisonous or corrosive fumes.

The form of battery described below was designed to cheaply overcome some of the annoyances commonly attendant upon the use of large or *intense* batteries as well as to economize space and labor of maintenance.

In Fig. 2, A is a sheet of copper, about eighteen inches long and ten and a half inches in width, bent U-shape lengthwise, and provided with a short copper strap or ear, at a B, Fig. 2, is a strip of zinc, about fifteen inches long and four and three-quarter inches wide. The flannel envelope, C, is made of one piece nine inches wide and twenty-one inches long, doubled upon itself and stitched together at *g* and *f*, so as to snugly envelope

the zinc plate. In setting up the battery, the copper is coated thickly with a paste of calcined lampblack and dilute sulphuric acid; the plate of zinc is fitted into the cloth envelope, previously moistened with dilute sulphuric acid, and this in turn is put into the copper so that the cloth projects an inch or more above and below the latter. It is necessary that the copper should firmly press upon the cloth envelope, but it must not touch the uncovered zinc plate. The couples thus arranged are packed tightly together in a wooden frame or case, with a sheet of paper saturated with paraffine between each, as shown in Fig. 1. The plates are then joined in series—the zinc of one with the copper of the next, and so on—the ears, *a*, and *b*, Fig. serving for connections. The tube P P', Fig. 1, is made of glass, or of pieces of glass tubing joined by vulcanized rubber tubing, and is connected with a reservoir D. At points *s, s, s*, along this tube, and just over the expanded ears of the projecting cloth envelopes, are arranged glass dropping tubes, so that when a liquid flows from the reservoir, D, through P P', an equal quantity of it escapes through each of these upon the cloth below. The flow of liquid from the reservoir can be controlled by the stopcocks at E and T.

The battery is operated as follows: The reservoir, D, having been filled with a solution of three-quarters of a pound of potassium bichromate and about one pound of sulphuric acid in a gallon of water, the stopcock, E, is opened, and the solution allowed to trickle slowly upon and down through the cloth envelopes, escaping at the bottom into a leaden or enamelled tray. The battery thus arranged develops a considerable electromotive force, and when the reservoir is properly adjusted, is remarkably constant. Should it become clogged up with chrome alum (and this does not often happen), or when it is not required for use, it can be cleaned without disconnecting it by allowing warm water, instead of the solution, to flow through the pipe, P P'. The zinc plates can be easily taken out without removing the envelopes. A battery of this kind of one hundred cells can be put up in a box three feet long, one foot wide, and two feet deep. It can be fed from a single reservoir, and will produce a very fair arc light.

ELECTRIC LAMP-LIGHTERS.

The accompanying cuts represent two forms of apparatus designed for the purpose of lighting and extinguishing lamps by electricity. The arrangement in both cases is shown in connection with the small lamps known as night lamps. Both are so constructed that the first current which passes through them lights the lamps, and the next extinguishes them. The currents can be established through several contacts, which form a galvanic circuit, in which is included the battery and the apparatus to be described.

In the base or frame on which the lamps are mounted, is placed an electro-magnet, which attracts an armature every time a current is passed through it. Attached to this armature are two straight or curved rods, which are united at their upper extremities by means of a spiral of platinum wire, which is heated to incandescence by the passing of the current.

The extinguishing arrangement of the Magnet system. Fig. 1, consists of a bellows, which blows a current of air into the flame and so extinguishes it, as often as the rods attached to the armature of the electro-magnet press upon it and cause it to close. When the current is kept closed for a little while, the bellows empties itself, and the platinum spiral, which is now directly over the wick, becomes incandescent and ignites the lamp. In extinguishing the lamp, the current should only be maintained long enough for the purpose, as otherwise the lamp would shortly be ignited again by the platinum spiral.

In the apparatus of Ränge, shown in Fig. 2, the flame is extinguished, not by an air current as in the arrangement above described, but by means of a cap, which is caused to come down upon the burner, and which stays in place upon it until it is desired to light it again. This device has certain advantages over the other, in that it prevents the deposition of dust upon the wick and hinders the evaporation of the oil or other burning fluid in the lamp. The rods attached to the armature carry a strip or band of steel, which, by the movement of the armature, first removes the cap from the burner and makes place for the glowing platinum spiral when the lamp is to be lighted; and when it is to be extinguished, puts the cap back again upon the burner.—*Manufacturer and builder.*

Rear-Admiral Bourgeois has been appointed by the French Government to preside over a committee requested to study the application of electricity in navigation.

IMPROVED ELECTRIC GENERATOR.

A great deal of attention is now given to the relief and cure of diseases without the use of drugs, and electricity is being recognized as one of the important healing agents for accomplishing this very desirable end. Hitherto it has generally been considered the prerogative of a physician to properly apply the electric current to curative purposes; but since it has been discovered that a mild continuous current is effective in the treatment of diseases, it is apparent that any one having the necessary appliances may use the electric current to advantage.

The engraving represents a very simple and compact generator or battery for creating a continuous electric current for curative purposes. It is a modification of the well known Trouvé blotting paper battery, and is capable of yielding a constant current for a long time. The inventors of this generator and its accessories state they have had batteries of this class in use yielding a current for over a year without attention, and it may be renewed at the end of that time without trouble or expense.

The rubber case contains two plates, one of zinc, the other of copper, each connected with a clamping screw extending through the cover. Flexible cords connect the binding posts with the electrodes, the latter consisting of two nickel plated disks, each having two slots for receiving a strap by which the electrode may be bound upon the affected part. The generator is carried in a pocket in the inside of one of the garments. This may be done with perfect safety, as the exciting fluid with which the generator is charged is entirely absorbed by the porous filling placed between the zinc and copper plates.

The electrodes are often worn on a belt, one being placed in front of the body, the other at the back. Fig. 2 shows the method of attaching one of the electrodes to a sponge for bathing purposes, and Fig. 3 shows its application to the hand when the current is employed to supplement frictional treatment.

There are a number of other methods of applying the current, which need not be described in detail here. Further information in regard to this invention may be obtained by addressing the Constant Current Cure Company, 207 Main street, Buffalo, N. Y.

BRUSH'S STORED ELECTRICITY.

Mr. Brush, whose lights make bright Scollary Square, and shine in other cities, comes to the front with his way of packing electricity for use when wanted, wasting none. Mr. Brush lives in Cleveland, O., and from the *Leader* and the *Herald* of that city the following is abstracted: Mr. Brush for a number of years past has been hard at work in this direction, overcoming first one difficulty and then another, and all the time refraining from any statements on the subject. He now for the first time makes the statement that by his methods the storage of an indefinite amount of electricity for an indefinite time, ready for use at any moment, is an easy and certain of accomplishment as the regular production of electricity by his dynamo-electric machine. Mr. Brush uses for his storage-reservoirs metal plates so arranged that they are capable of receiving a very large charge of electricity and of holding it for an indefinite time. The storage reservoirs vary in size as desired, may be transported from place and used as desired. They may be put to any use of which electricity is possible. They can be taken about in wagons by day and left at the houses of citizens, like so much ice or kerosene, and used at night. Each citizen may then run his own electric lights as he pleases. The plates can be put on street cars, connected with the axles, and made to run the cars without horses. Steam cars may be ultimately run in the same way. Mr. Brush's last invention is only now a case of economy. For some uses it will be cheaper, for others more expensive, than the present methods of obtaining power. The practical character of the invention is settled. The engines can be run and electricity accumulated during the day, and then at nights two sets of lights can be run, one set by the power stored up. An indefinite amount of electricity can be stored in this way, and used as wanted. The details of the method cannot now be made public.

The first electric railway in Upper Silesia has been erected in connection with the colliery of the Donnersmarckhütte Company, to supersede the ordinary horse-railway. The current is conveyed by wire ropes supported on poles in the same manner as telegraph-wires. On the wires run small contact carriages, connected with the locomotives by wires. The maximum speed will be eight miles per hour. The locomotive is similar to that exhibited two years ago at the Industrial Exhibition, but is somewhat smaller. The line and its accessories were constructed by Messrs. Siemens and Halske.

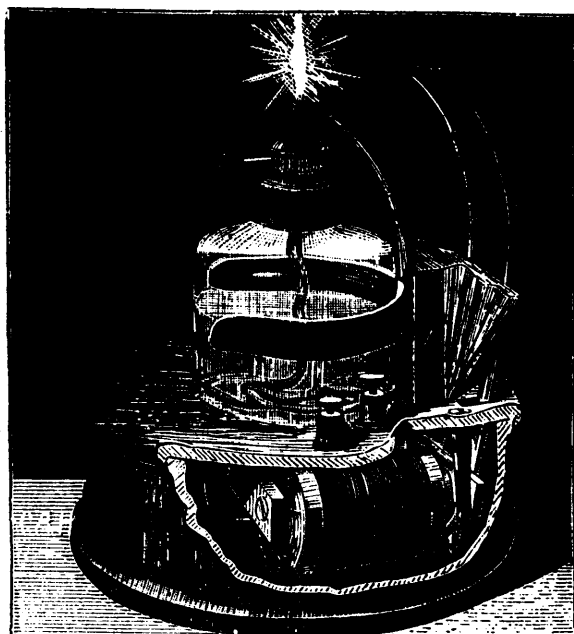

FIG. 1.—MAGNET'S ELECTRIC LAMP-LIGHTER.

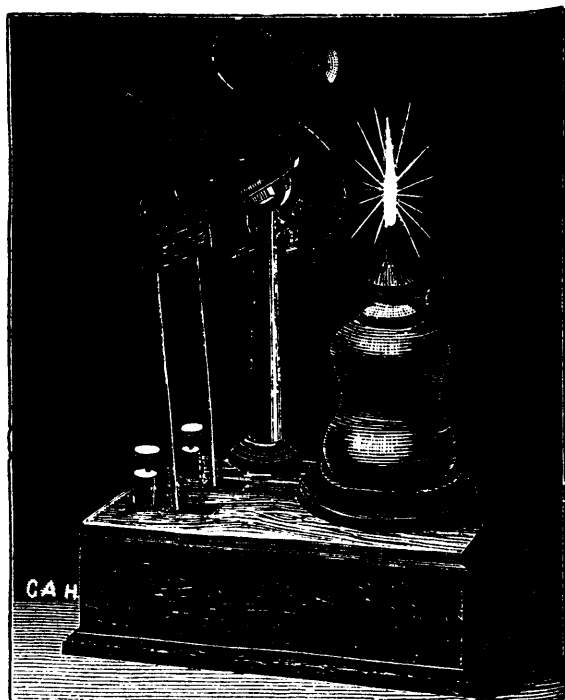
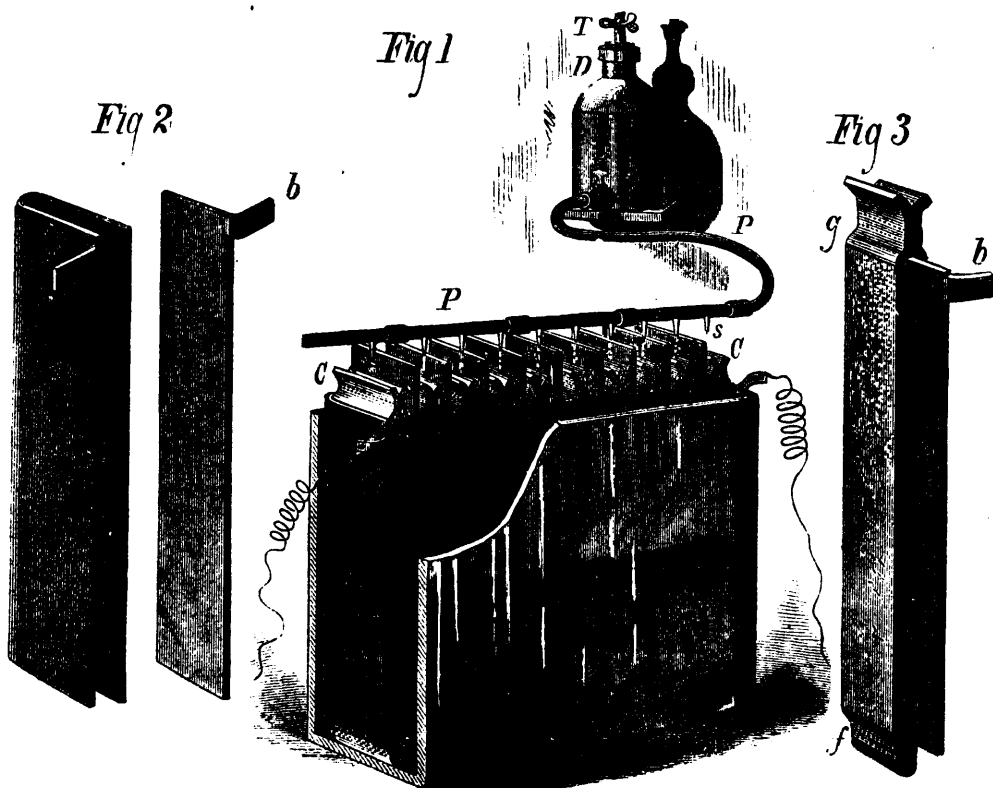
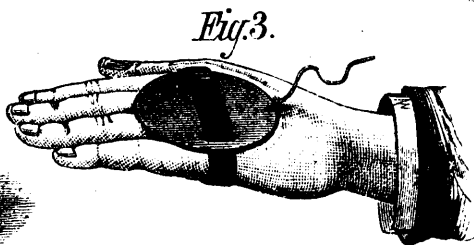
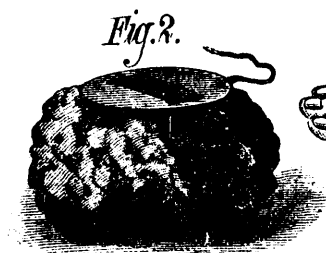
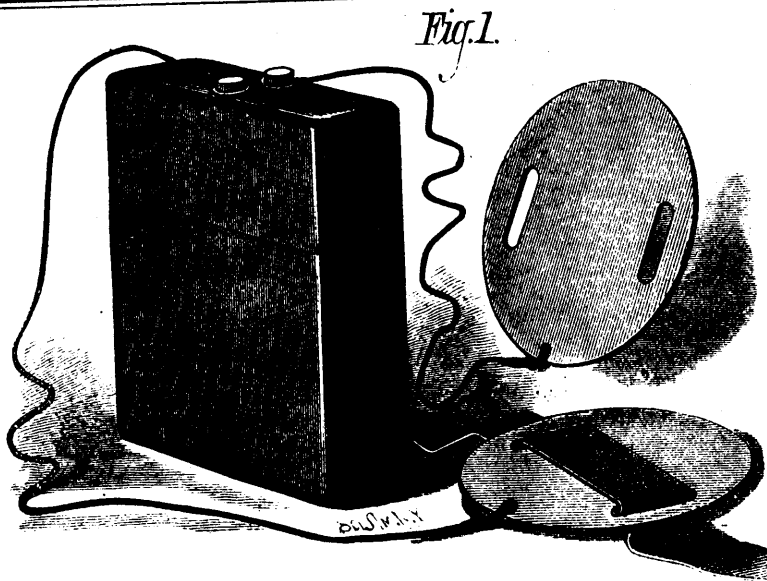

FIG. 2.—RANGUÉ'S ELECTRIC LAMP-LIGHTER.



FOUNTAIN BATTERY.



CONSTANT CURRENT ELECTRIC GENERATOR.

NEW PORTABLE BATTERY.

We give an engraving of a very compact and powerful battery recently patented by Mr. Marcus A. Hardy, of Newport, R. I. It is designed for medical and experimental purposes, and is very convenient and portable. The battery comprises twenty elements, and the cells are made in one entire piece of hard

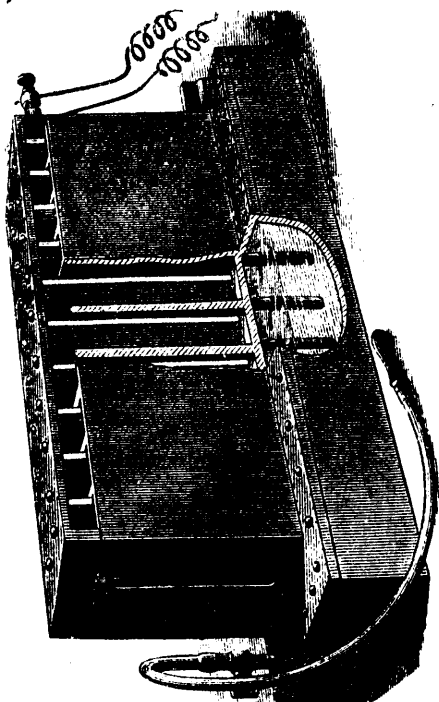

HARDY'S PORTABLE BATTERY.

rubber which is known to be indestructible with proper use. The construction of the battery is such that all the cells can be filled in twenty seconds from the reservoir forming the base, and the exciting fluid remains in contact with the zincs and carbons only during use. Any number of cells, from one to twenty, may be brought into use as may be required. The battery cell forms the top to a hollow base or reservoir, and from each cell a small tube projects into the hollow base nearly to the bottom. To the base at one end is attached a stopcock, to which is connected a rubber tube terminating in a mouthpiece. At the opposite end of the reservoir there is a screw-capped opening for introducing the exciting liquid. The zinc and carbon plates are attached to brass connecting pieces secured to a common support of hard rubber. The connections are arranged so that the zinc of one cell is in electrical communication with the carbon of the next, and so on throughout the series. The opposing ends of the series are connected with binding posts at the end of the battery.

The brass connectors between the elements are drilled so that plug connections may be inserted to cut out any number of cells.

This battery finds an extensive application in torpedo service, and it appears to be extremely well adapted to laboratory use.

A NEW TELEGRAPHIC DEVICE.

A California paper, the Sacramento Chronicle, gives an account of a device for the simplification of telegraphy, by which anyone who knows the alphabet and how to spell can correctly transmit telegraphic despatches. The invention is a substitute for the key, which requires training in order to be used. It consists of a piece of metal in which are inserted conductors of brass and non-conductors of whalebone that correspond with the characters of the Morse Alphabet. Each letter or numeral is divided off and marked. By moving a metallic pencil over anyone of these divisions, the particular letter or figure is reproduced at the other end of the line by means of the insulations and connections. One stroke suffices for a character, while greater precision is obtained than by the key, as on account of the mathematical accuracy of the device, letters or numerals cannot be run together as now too frequently occurs.

Notes and Clippings.

UNFINISHED TOOLS.

Some times ago the writer was asked, by letter, why our machine tools are not sent ready to operate, barring the inevitable setting-up, leveling, hanging counters, and adjusting belts. Since the reception of the latter he has made inquiries of builders of tools, and so far has failed to get a satisfactory reply. In several instances it is a "*Cosas d'España*," an old custom, that should not be changed because it is a custom. When in Spain the traveler asks, "why is this thus?" he is met by the reply, "it is a custom of Spain." In other replies the writer was informed that the operators of the new tools preferred to put their tools into shape to suit their own demands.

There appears to the operative and observant mechanic no special demand for unfinished tools, especially now, when there is such a demand for operative machinery. When a man buys a lathe for instance, locates it, adjusts the counter shaft, and puts on the belt, he ought to have a tool ready for work. But, instead of that, he finds both centers lacking a point. They must be turned to gauge before a stud or shaft can be suspended between centers and worked. If there is any reasonable reason why the centers of a lathe are not ready for use when the lathe is placed in *situ*, the writer has not yet found it.

In most shops where the lathe is built, the test of agreement between the axis of the spindles and the ways of the lathe is determined by very severe tests—the centers of head-stock and tail-stock are proved by trial and determinate shafts that fit alternately into one and the other center holes of the respective spindles. This trial not only determines the agreement of the two spindles, but also determines the agreement of the centers of each spindle, with the ways that guide the carriage that carries the cutting tool. It is evident, therefore, (if the entire work has been properly done), that the centers of the lathe might as well be finished to the proper angle of 60° as to allow the purchaser the luxury of reducing them from a cylindrical to a cone-like form. It seems that there is room for improvement in this old-time practice.—*Boston Journal of Commerce*.

NITROGEN AS NITRIC ACID.

When a large crop is obtained by the application of a mineral manure such as Potash or Phosphate, it is due to the fact that the liberated Nitric Acid is quite equivalent to the growing power of the mineral food in the soil, available for the use of the crop. After a few years' application of these minerals alone, it would be found that they were less effective than when first used; they would then accumulate in the soil, only to become the food of plants when aided by an artificial supply of Nitrogen. In one of our experiments upon permanent wheat, 8,000 lbs. of Sulphate of Potash, and the same quantity of Superphosphate of Lime have been applied to one acre of land during the last 38 years; almost the whole of this amount is now lying in the soil within reach of the crops, but unavailable for the use of the plant, owing to the absence of Soluble Nitrogen. Plants then derive their Nitrogen principally from Nitrate of Lime formed from the organic Nitrogen existing in the soil; but if a larger amount of produce be required than this Nitrate is competent to supply, recourse may be had to Nitric Acid in the form of Nitrate of Soda, or Ammonia, or Organic Nitrogen and the value of these substances is, in some degree, in proportion to the readiness with which they are converted into Nitric Acid.

The general idea that Nitrate of Soda acts as a stimulant to vegetation is incorrect. The action of Nitrate of Soda is due to the fact of its furnishing plants with one very important element of their food, Nitric Acid; the soil furnishes the same substance but not always in sufficient quantities, and the question as to when it will be profitable to employ so costly a substance, is one that cannot be answered without a full knowledge of all the circumstances of the particular locality.

My experiments show that, even when little or no loss of Nitrogen takes place from washing, a very considerable proportion of the amount supplied is not recovered in the crop; it is evident, therefore, that in the States, where nitrate is as costly as it is in England, and where a lower range of prices prevails for farm crops, some caution must be used in its application.—J. B. LAWES.

It has been resolved to invite the British Association to meet in Aberdeen in 1883. The invitation will be presented at the forthcoming meeting of the Association at York. The Association will meet in Southampton in 1882, and an influential local committee has already been appointed.

Miscellaneous.

KING'S-CROSS Station London, is now lighted by means of electricity, a beginning having been made last week by means of the Crompton system. There are 12 Crompton lamps within the station six being placed over the arrival, and a similar number over the departure platform. Two other lamps of larger size are placed outside the station building. The interior area lighted consists of two bays, each 880 ft. long and 105 ft. wide and 72 ft. high, as well as the cab-rank adjoining the arrival platform, which is 40 ft. wide. The total area lighted is 220,000 square feet, giving an area of 18,333 square feet, or nearly half an acre, to each lamp. The lamps are suspended at a height of 30 ft. from the platform level, and are arranged on four circuits, the light of each lamp being computed as equivalent to 4,000 candles. Any unpleasantness from the intensity of the light, is obviated by the use of semi-transparent glass in the lower portion of the lanterns. The two exterior lights are estimated at 6,000 candles each, and are placed at an altitude of 70 ft., the lanterns being of clear glass. The current is supplied by means of five Burgis dynamo-electric machines, which are driven by a semi-portable engine by Messrs. Marshall, Sons, & Co., of Gainsborough, working up to 35-horse power.

Among the exhibits of the Paris International Exhibition of Electricity may be noted the Italian historical section, which is full of relics used by Galvani, Volta, &c. There are a large number of autographs, among them a letter from Volta to Sir Joseph Banks, then president of the Royal Society, a document which is stated to be the first description of the Voltaic battery, ever written by its inventor. A small magnet which Galileo armed with his own hand, is exhibited, as well as another magnet used by the Academicians "del Cimento" for their determination of the laws of the variation of the attractive power according to distance. The Academy of Acrostation of Paris exhibits a model of the electro-subtractor, an electrical balloon constructed according to the principles advocated by Dupuy de Lome, and a number of other electrical instruments. M. Jules Godard, a well-known aeronaut, has sent an electrical warner; when the balloon is descending an electrical vibrator is set in operation, when it is ascending another bell is put in action—an effect which is produced by means of a delicate equilibrium valve operated by the motion of the air.

The President's sick-chamber has been supplied with cold air in the following manner: According to the inventor's description, the apparatus consists of a cast-iron chamber, about ten feet long and three wide and three high, filled with vertical iron frames covered with cotton terry or Turkish towelling. These screens are placed half an inch apart, and represent some 3,000 ft. of cooling surface. Immediately over these vertical screens is placed a coil of inch iron pipe, the lower side of which has fine perforations. Into a galvanized iron tank, holding 100 gallons of water, is put finely granulated or shaved ice (and salt when a low temperature is required). This water is sprayed upon the sheets in the lower tank constantly. In the outer end of the chamber is a pipe connected with an outdoor air conductor. To the opposite end is connected a similar pipe leading into an ice-chamber at its top, and from the bottom of the same a pipe leads to a small exhaust fan, and from the fan the cold and dry air is forced direct into the President's room through a flue some 20 ft. in length.

A steam catamaran has recently made its appearance in New York waters as a new form of passenger-boat, with an enormous carrying capacity for the size of the hulls. A catamaran, in the American sense is, a boat with two hulls, separated by some considerable distance. The new boat, which is the invention of J. Evertsen, of Troy, New York, has a very light draught, is only 60 ft. long, with a beam of 6 ft. for each hull, and has a carrying capacity equal to 400 persons. The propeller is hung between the hulls, and there are usual two decks, which form the most prominent feature of American river steamers. The upper deck is broad and open, with only the pilot-house and captain's cabin to interfere with the view.

THE Americans can produce bigger obelisks than that recently transported across the Atlantic at so much expense. At a granite quarry in Westerly, Rhode Island, they have recently detached a monolith, 150 ft. long, 10 ft. wide, and 8 ft. thick, weighing over 1,000 tons, and the owners say they could finish it as an obelisk and erect it in New York for 150,000 dollars. The block was loosened by one oblong blast-hole in a simple and easy manner, and the proprietors of the quarry would like orders for all the obelisks they can produce.

Mechanics.

IMPROVED FREIGHT AND PASSENGER ELEVATOR.

The convenience and economy of elevators and hoists for passenger and freight service, in the saving of time and labor, have come to be so generally known and acknowledged, that at the present time no large business building or hotel is considered complete or desirable without one or more of them; while in mercantile and manufacturing establishments they have long come to be looked upon as indispensable for the rapid and convenient handling of goods and freight. The requirements of first-class machines of this class demand that they shall be simple in construction, durable in service, not liable to derangement, that they shall possess an excess of strength beyond any reasonable demand they will be called on to meet, and, above all, that they shall realize the conditions of absolute safety as nearly as possible. These requirements are by no means simple and easy of realization. The makers of elevators had much to learn that could only be taught by experience, and during the twenty years or so that have passed since the introduction of the passenger elevator, the class of machinery has been vastly improved upon, by the expenditure of much care and ingenuity, until at present it has been brought to a very creditable state of perfection.

We illustrate in the accompanying engravings, and describe in what follows, several forms of the elevators manufactured by L. S. Graves & Son, of Rochester, N. Y., who have gained considerable repute as representative manufacturers of this class of machinery. The firm in question manufacture all varieties of hoisting machinery, including power, hydraulic and hand elevators. Our illustrations represent two varieties of the power machines, the screw and geared machine for passenger service. The manufacturers, in the variety of the machinery they build, have endeavored to meet the various requirements of elevator service. The kind of elevator to be adopted will depend upon the location, the character of the building, the nature of the business, and the power most convenient to drive it. What would be best for one set of circumstances, therefore, will not be suitable for another. The manufacturers of these machines, therefore, recommend their steel screw machine (of four sizes) where parties have steam or power in their building, and want a first-class, noiseless-running elevator, wholly or in part for passenger use. Where a machine is desired for heavy freight uses, as in a manufactory or machine-shop using power, and where the running of toothed gearing is not objectionable, the makers recommend their geared machines (of three sizes), as answering the purpose best. If in a hotel, commercial building, drygoods, clothing or similar establishment, where power is not wanted or used for other purposes, and where the city or town is supplied with a system of water works at a pressure of from 25 to 100 pounds, and charges are not extravagant, they recommend their hydraulic elevator. In such cases, the cost of the last named would be much less when compared with that of putting in and maintaining steam power. The heat, steam, smoke, danger from explosion, increased insurance, etc., would also be avoided.

Coming back, after these preliminaries, to the description of the special machines named in the foregoing, we invite attention to Figs. 1 and 2, which represent respectively the No. 2 screw machine erected and in operation, and the hoisting mechanism of the machine. The machine is shown in use as a freight elevator, but can readily be transformed into a passenger elevator by substituting a passenger car in place of the open platform. In either case, the hatchway should be completely enclosed from top to bottom, by a wire screen or glass-panel doors on each floor, to be opened only from the inside by the attendant on the car or platform. Side or corner platforms are used, according to the necessary location of the machine.

The position and location of the winding machine, also, can be varied to suit the location of the driving shaft in the building. Fig. 1 shows its general arrangement, when secured to the floor overhead, in its working position.

These machines are equally well adapted for freight and passenger service. They run smoothly and noiselessly, are not liable to become disordered, are very durable in service, and consume the minimum of power. The screw is made of cast steel, forged solidly upon the driving shaft, and cut and finished with special tools. It runs on three hard Babbitt, self-oiling bearings, placed above the worm-gear, which concentrates all the strain on the strongest parts of the frame, and carries the pulleys and belt high out of the way. The worm-gears are made of copper and tin proportioned for the hardest anti-friction metal, and are ex-

posed where their condition can be seen and examined at all times. These machines are fitted with improved automatic stop motion, which is adjusted to the height of the building, and prevents the winding drum from making more than the number of revolutions required to take the platform from the bottom to the top, where it is automatically stopped, without any connection with the shipping ropes. The loose pulleys have long bearings lined with composition sleeves, and have large self-oiling chambers.

Screw machines Nos. 3 and 4 are constructed on the same principle as No. 2 above described, but are larger, and adapted for the heavier and more expensive class of freight and passenger service. With these elevators, the winding machine is built to rest upon the floor or foundation close to the hatchway, where it will be more accessible and likely to receive better care and attention. Fig. 3 represents the hoisting mechanism of the No. 3 screw machine. These machines are constructed of the same materials, and are provided with the same special appliances as the No. 2 machine above described.

Fig. 4 represents the mechanism of the geared elevator No. 3, made by the same firm. These machines, while not suited for passenger service by reason of the noise and jar attending the working of toothed gearing possess all the requirements of simplicity, strength and durability which are needed in a freight elevator, for which they are specially designed.

Geared machine No. 3 has a 24 inch winding drum, screw geared, to receive the wire rope. The gearing is heavy, and runs comparatively noiselessly. The journal boxes are long, Babbitt-lined, and have self-oiling reservoirs and oil drippers. The loose pulleys have long bearings and self-oiling chambers. A double cam and two shipping rods permit each belt to be moved separately, rendering them easier to operate and with less wear than with the usual way of shipping both belts when it is only desired to move one. A heavy steel spring, with screw adjustment, is used to put on the brake and hold the load, and also serves the purpose of bringing and holding the belts to their proper places on the loose pulleys. These machines are provided with a safety governor, designed to avoid the danger of their running down suddenly with a load in case the belt should break or the brake become deranged. Its operation is such that should the platform from any cause go down faster than its usual rate of speed, a powerful brake is brought to bear on the pulley shaft, keeping it within a safe speed of descent. When it is down, the governor returns to its former position.

The hydraulic elevator has, by general consent, come to be recognized as the passenger elevator *par excellence*. The general advantages of this system over the use of steam power have been briefly referred to at the outset of this article, and have been fully detailed in previous articles that have appeared in this journal. They do not, therefore, require to be rehearsed in this connection.

Messrs. L. S. Graves & Son, in inviting attention to their special build of hydraulic elevators, lay stress on the fact that they prefer to build the horizontal hydraulic engine with the continuous wire rope and sheave system. In behalf of this preference, they claim that this form of engine best serves the requirements of the hydraulic elevator in respect to safety from accidents, economy of water, simplicity and freedom from derangements, and durability in service. Furthermore, the engine, valve and connecting pipes are set upon heavy timbers and masonry upon the basement floor—high, dry and clean, and easy of access for oiling or repairs. The working parts, the piston and its connections, are carried on wheels and run on iron rails, perfectly balanced in any position. If necessary to economize room, a shelf or bench is built directly over it for the storage of goods. Also by its position in the basement or sub-cellar (generally the least valuable room in the building), it receives the maximum pressure from any source of supply, whether it be a tank on the roof or from the street mains, as the pressure, or the working power, is due to the height of the source of supply from the hydraulic engine, consequently the manufacturers guarantee the greatest possible lifting capacity from the amount of water used.

In some forms of the hydraulic engine, where they are confined to the basement, they require to be set several feet below the surface, which is very objectionable in many respects. In other forms more commonly used, the cylinder and working parts extend up the whole height of the hatchway, necessitating about one-third larger hatchway for the same size car than it would if these parts were confined to the basement, occupying from 10 to 20 square feet on each floor of the most valuable room in the building; and as these working parts, weighing many hundred pounds, are suspended high above the head, besides being very unsightly, are suggestive at least of serious accidents.

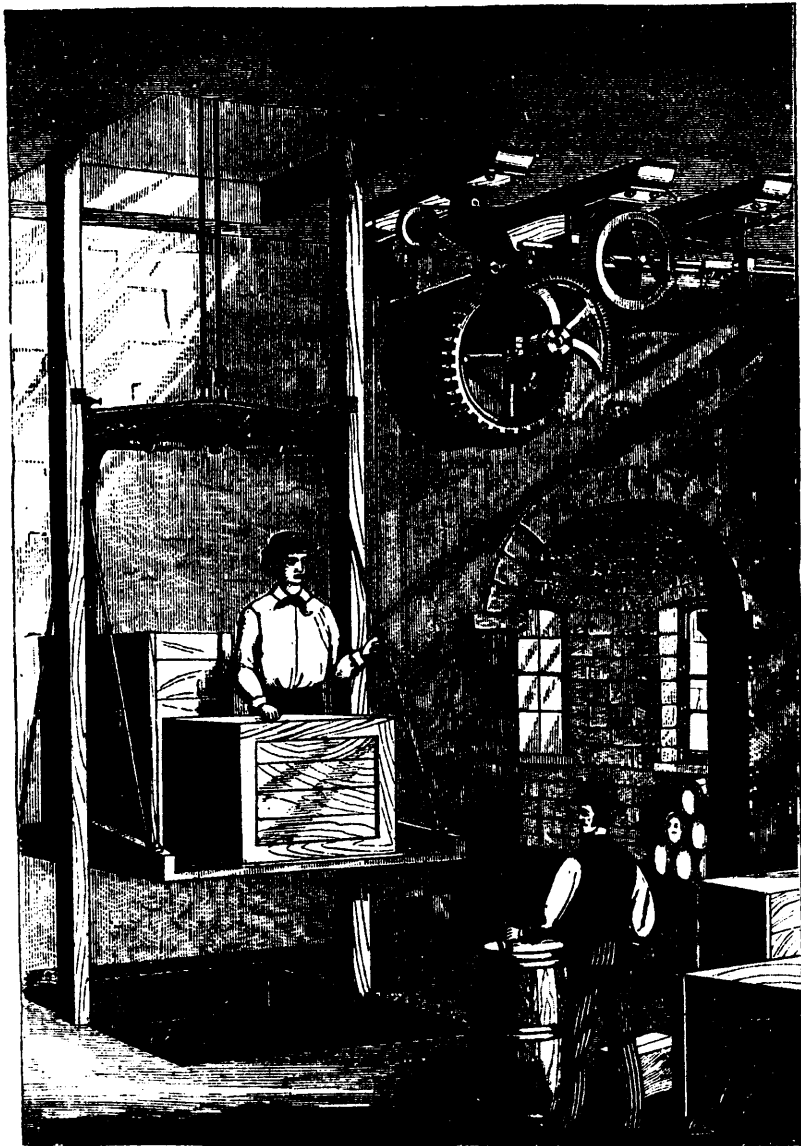

FIG. 1.—No. 2 SCREW MACHINE-ERECTED.

Fig. 5 represent the medium sized hydraulic engine manufactured by this firm.

To meet the demands of an increasing business, the firm of L. S. Graves & Son have lately removed to a new and much larger building, supplied with additional accommodations and facilities. This building is located at the corner of Center and Front streets, Rochester, N. Y. The building is 108 by 50 feet in area, having four floors containing over 2,000 square feet of flooring. The basement is appropriated to the department of casting and forging, and the general preparation of cast and wrought iron used in the construction of passenger and freight elevators, boot and shoe machinery, etc. The first floor devoted to the machine-shop,

and is equipped with new and improve lathes, drills, and other mechanical appliances used in making the gearing and machinery needed to operate elevators. The upper floors are used for pattern-shop and wood working departments, for the manufacture of platforms for freight elevators and cars for passenger elevators.

The elevators of this firm have been very largely introduced, being in especial demand throughout the Eastern States. Over one hundred are at present in use in Rochester alone. They are likewise in very general use in New York city, Hartford, Albany, Troy, Syracuse, Utica, and other important localities, and have made a good record wherever they have been introduced.

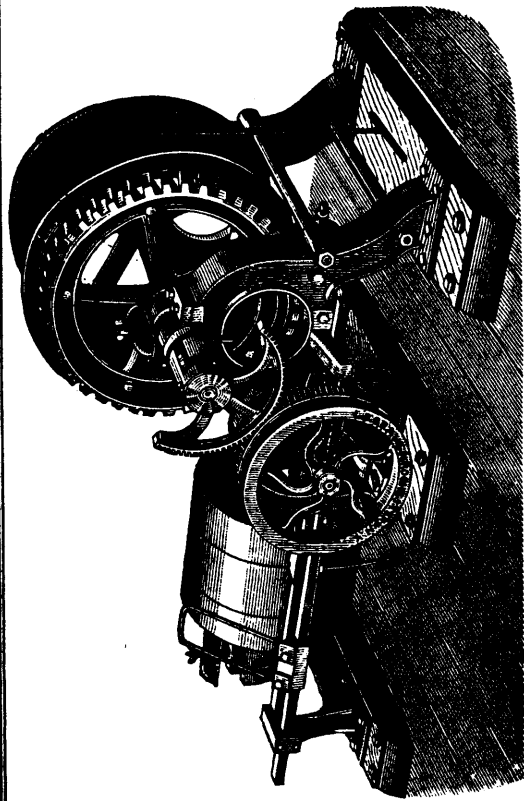

FIG. 2.—SCREW POWER HOISTING MACHINE, No. 2.

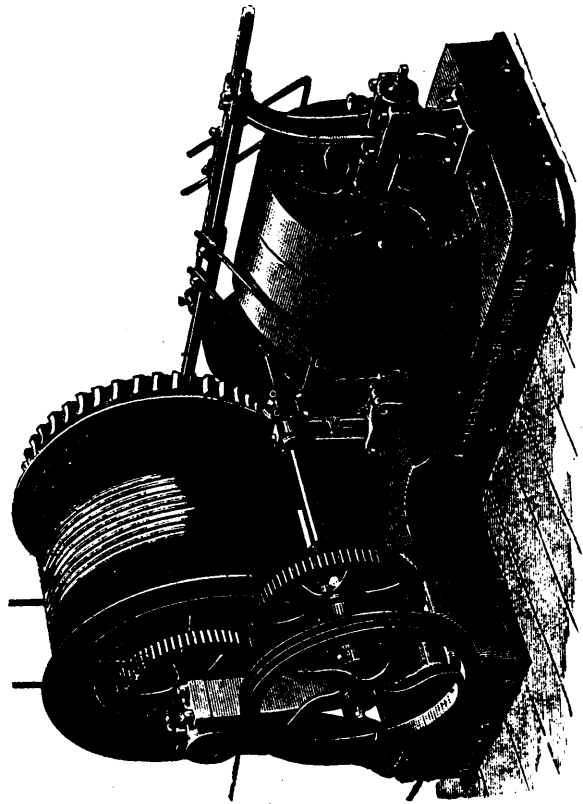

FIG. 3.—No. 3 SCREW MACHINE.

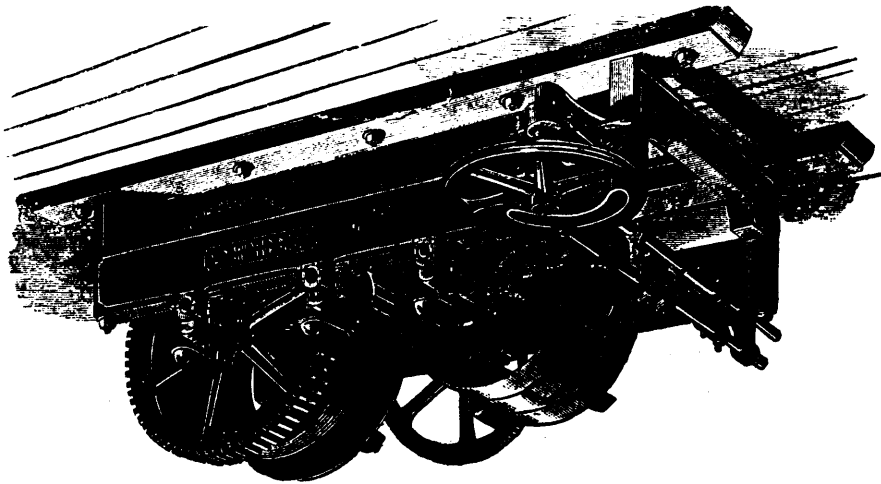

FIG. 4.—No. 3 GEARED MACHINE.

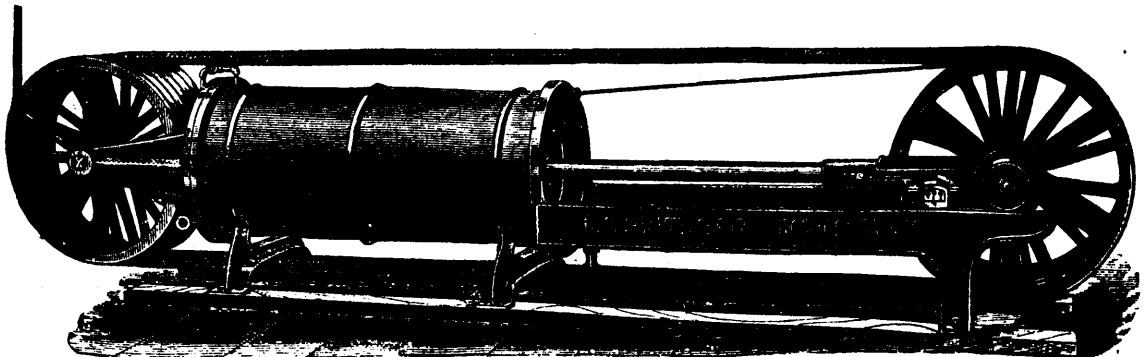

FIG. 5.—HYDRAULIC ENGINE.

Sanitary.

WHOLESOME WATER.

Of late years since sanitary science has received official recognition in all civilized countries by the establishments of Health Board and Sanitary Commissions, the question of maintaining the purity of the water supply of cities and towns has come very properly to be considered as one of the greatest importance. Few even of generally well informed people are fully aware of the immense benefits derived by the dwellers in crowded cities wherever intelligent and properly directed efforts have been put forth to prevent the pollution of the source of their water supplies, since the results accomplished do not make themselves readily manifest on the surface; but the story is told too plainly to be misunderstood, in the yearly statistical reports, wherein the record of a diminished death rate from preventable diseases bears silent but eloquent testimony to the efficacy of sanitary measures in improving the general health of crowded communities.

We do not mean in the above remarks to imply that maintenance of the purity of the water supply is to be credited with all the benefits which official sanitary supervision has conferred, since many of these are properly to be ascribed to efficient sewerage systems, the prompt and thorough removal of filth and garbage from the streets and alleys, the maintenance of general cleanliness, and the rigid enforcement of measures for preventing the spread of infectious diseases. But the preservation of the purity of the water supply must, nevertheless, be credited with a fair proportion of benefits resulting from the proper sanitary care of cities and towns.

The determination of the wholesomeness or unwholesomeness of a sample of water is, however, by no means an easy matter, since taste, smell and color do not always constitute infallible tests of its qualities; for though we may reject as unfit for use waters that contain visible impurities, or that possess a disagreeable taste or odor, these are in many cases practically harmless when compared with others that give no outward indications of danger that may be detected by the senses, but which, nevertheless are contaminated by the most insidious of poisons—the germs of infectious diseases. Contradictory as it may seem, therefore, a perfectly limpid water, free from disagreeable smell or taste, may be infinitely more dangerous than another that is obviously offensive to the sight, and disagreeable to the taste or smell. This apparent contradiction, however does not alter the fact, that in a general sense, a wholesome drinking-water should be clear to the eye, pleasant to the taste, and free from offensive odor.

Perfectly pure water does not exist in nature, although rain water is so nearly pure that we may consider it so for all practical purposes; but such are the solvent powers of water, that it may be said to take up more or less of every substance with which it comes in contact. Hence it is that water that has penetrated for a considerable distance into the soil and through the crevices of the rocks, and subsequently makes its appearance upon the surface in the form of springs, or through artesian wells, etc., is generally more richly charged with mineral matters than the surface waters of rivers or of shallow wells. Such mineral constituents, which commonly consist of the carbonates (bi-carbonates), sulphates or chlorides of lime, magnesia, iron, soda or potassa, cannot be looked upon as notably injurious to health, save where present in excessive quantities: on the contrary, these and other mineral constituents in the slight quantities in which they are found in the so-called "mineral" or "thermal" waters, often have special medicinal or curative virtues which cause them to be highly esteemed. For most practical purposes, therefore, where mineral constituents in not excessive quantities are the only impurities in potable waters, they may safely be ignored.

The surface waters, such as those of lakes, rivers, etc., from which the water supply of cities and town is generally obtained, are, however, peculiarly susceptible to quite a different species of contaminations, which is productive in many cases of such pernicious results to the health of communities as to have raised the question of the purity of the water supply to the first rank among sanitary considerations. We refer here to the pollution of rivers, etc., with sewage matter, consisting largely of animal excreta, to the effects of which medical men are unanimous in ascribing the occurrence of typhoid and allied fevers, dysenteric epidemics and the like. This is no mere opinion, but a strictly legitimate inference from a legion of observations, in which the relation between cause and effect has been ascertained beyond the possibility of a doubt.

In considering the question of the purity of the water supplies of cities and towns, we are confronted with complications of a special character—contamination from the refuse of gas works, manufactories, from the lead of the pipes in which it is served, and the like; but these forms of contamination are, taken all together, of very secondary importance when compared with the one above named. It is most fortunate, therefore, considering the almost universal practice which prevails in this country, of discharging the contents of sewers, laden with the refuse and filth of large communities into running streams which further down are drawn upon to supply other cities and towns upon their banks with water, that nature has herself supplied what in most cases is a tolerably efficient remedy for what otherwise would prove to be a most pestilential and deadly evil, in that she has given to the running streams the power of self-purification. The movements of these bodies of water, by constantly bringing fresh portions of their load to the surface and in contact with the atmosphere, rapidly causes its destruction by oxidation, so that a river, for example, that has received the sewage impurity of a city, will, under favorable circumstances, be pure enough to drink a few miles below it. In this manner, therefore, in spite of the constant pollutions of the streams, the purifying efforts of nature are measurably effective in ameliorating the evils that would otherwise result therefrom.—*Manufacturer and Builder.*

Cabinet Making.

HINTS FOR DECORATORS.

Flowers have, from time immemorial, been used by peoples of various climes and nations, professing different religions, and speaking different tongues, for decorative purposes. In pictured floral representations there are some rules that should never be lost sight of. No one possessing the least amount of taste would for a moment contemplate the possibility of placing hothouse flowers and wild flowers side by side in a bouquet. So also in a painting they would be equally out of place near each other. Flowers in bloom at the same season should be painted in the same piece, thus Spring and Autumn flowers should never occupy one panel, because it is working contrary to nature. Follow nature as far as possible in this respect, and there will be no fear of anything like bad taste being evidenced in the picture. The composition of the design depends to a great extent on the size and form of the panel. Long, narrow panels, such as are found in doors, shutters, and dados, require tall flowers, as lilies, arums, and flags; or else climbing plants, as the convolvulus, the wild rose and bramble; water plants, bulrushes, and ferns can also be employed. Any climbing plant is useful, on account of the pliability of the stems, which allows of the sprays being thrown in any direction that suits the work in hand.

In all cases let subjects be in keeping with the position they are to occupy. They should done in colors that harmonize best with their surroundings, they should never be so obtrusive as to detract from the size and form of the object they are intended to beautify, but, at the same time, their details should not be of such a character as to be unappreciable at a distance; and, above all, the artist must bear in mind that decorative effect is the principal aim to which he should direct his strongest efforts, and that a broad free style will conduce to this end, rather than a high finish and fine minute details that are suitable mainly for miniature painting. One point never to be lost sight of is that the drawing of the design must be true, nothing compensating for bad drawing; the conception may be artistic, the coloring harmonious, the method of applying the colors masterly, but if the drawing be untrue all the labor expended on it is lost and worse than useless. One or two sorts of flowers thrown deftly together are preferable to the grouping of many kinds, which is apt to produce a confused effect much to be deprecated, especially in room decorations not seen in close proximity but usually at a distance, on which account also it will be found expedient to use large flowers rather than smaller sorts. Figures are, in some cases, as desirable as flowers and fruit, and, if the artist is a good draughtsman, there is no reason why they should not be employed for certain decorations, but any fault in the drawing is still more noticeable in *genre* painting than in flower pieces.

In October Prof. Bunsen will celebrate the jubilee of his doctor's diploma, as on the 17th of that month, fifty years ago, he received the degree from the University of Gottingen.

CORNICER MITERS.

A few years since a cornice workman's ability to develop what were called pinnacle miters, was conclusive evidence of his fitness for the position of pattern cutter or foreman in an average cornice shop. The writer's first introduction to the art and mysteries of mitre cutting was in a shop in which at the time a very considerable number of Gothic pinnacles were being constructed. The patterns used in the shop were all gotten out by the proprietor—a German—a man of exceptional mechanical ability and insight in many particulars, but quite as arbitrary in others as any of his nationality. All the patterns had been cut for these pinnacles, except the mitres at the eaves of the gables between adjacent sides. It was after working hours, and all the men had gone home. My German friend was busily engaged upon the parts in question, fastening short sections of the moulding upon two gables, and, by scribing their ends where they touched, gradually marking out a pattern for the part by the old rule variously described. Some call it the "ship car-penter's" rule, others the "cut-and-try" rule, and still others the rule of "main strength and ignorance." The writer at once volunteered assistance in holding the parts, and a conversation upon pattern cutting ensued. My friend's ability upon ordinary patterns was well known, and this was the first time I had ever seen anything in his work which looked as though he was beyond his depth. He was much better qualified for his work than most mechanics who, at that time, had undertaken the manufacture of sheet-metal cornices. As a boy in Prussia, his native country, he had attended a technical school—had, in fact, learned his trade under competent instructions in a school organized for such purposes. He had pursued the study of practical geometry under the immediate care of no less a person than Prof. Raetz, the author of a German work on pattern cutting with which many of our readers are familiar. In every matter to which my attention had before been called my friend had done credit to his teachers and the school from which he was a graduate. Knowing these facts, I was somewhat astonished at seeing his method in this particular case, and asked him why he did not use his drawing-board and tools instead of cutting and fitting. Not to be cornered, and unwilling to own his real perplexity, he entered upon a long explanation of how it was that certain miters could not be cut by geometrical rule, and to be satisfactory in all respects must be cut by fitting upon the actual work as he was then doing. It is needless to say that the argument did not appear conclusive, although at that time the writer knew absolutely nothing about pattern cutting. The conversation in question was one of the first things to call his attention to the need of systematic instruction in that important art. The incident passed with very little thought at the time. My friend's statements were not disputed, but as they came up in memory at intervals afterward, the mental comment was—"very strange, if true." All this was long before the days of *The Metal Worker*. Otherwise, some effort would undoubtedly have been made towards learning if other mechanics held the same views. The pinnacles were duly finished, shipped to their destination and put in place. I have seen them several times during the years that have passed since their construction, and have often reverted in mind to the conversation that occurred that evening in the shop when they were being made. Once afterward I saw my friend in perplexity over a sheet-metal pattern. It was an O G transition piece between a square base and octagon shaft. It was after this second incident that the course of investigation was determined upon, the results of which have appeared in *The Metal Worker* during the past four or five years, and the complete record of which will be shown in the new pattern book now nearly ready to send out. The present article will be devoted to an explanation of the geometrical principles of cutting pinnacle miters which so puzzled my German friend upon the occasion referred to. Its preparation has brought fresh to my mind the incident described. My friend went to his long home some years since, and, therefore, this account has not been penned for his perusal. He learned to cut pinnacle miters before his death, and often laughed at the conversation of the evening when he attempted to explain why certain miters could not be cut by rule.

Fig. 18 shows the elevation of one of four similar gables occurring in a square pinnacle. The profile of the moulding is shown by P. The first step is to obtain the miter line shown at K, from which to measure for the pattern. Draw the profile P in the moulding, as shown, placing it so that its members will correspond with the lines of the moulding. Draw a second profile, P¹, in the side view of the gable, placing it, as shown in the engraving, so that its members will coincide with the line of the

side view, and also with the first profile already drawn. Space both of these profiles into the same number of parts in the usual manner, and through the points thus obtained draw lines parallel to the lines of the elevation, as shown. Trace a line through these intersections. Then K is the line in elevation upon which the mouldings will mitre. Draw the mitre line O M for the top of the gable, as shown. Upon any line, as G H, drawn at right angles to the line of the gable in elevation, lay off a stretchout of the profile, as shown by the small figures. Through these points draw measuring lines, as shown. Place the T-square parallel to the stretchout line, or, what is the same, at right angles to the line of the gable, and, bringing it successively against the several points in O M and the miter line K, cut the corresponding measuring lines, as shown. Make E' D' equal to E D of the side view of the gable, and set it off at right angles to E' B'. In like manner, at right angles to the same line, set off A' B' equal to A B of the view side. Draw the line indicated by A' D', as shown, and trace lines through the intersection of point dropped from the elevation on to the measuring lines, thus completing the patterns.

Another way of making a joint in this position is shown in Fig. 19. Let A C be one of the gables in profile and B D the other in elevation, the mouldings forming a joint against a ball, the center of which is shown at E. For the patterns proceed as follows: Place the profile in each gable as shown by F and F', locating them in such a manner with regard to their respective positions that corresponding points in each shall fall upon the same lines. Divide each of these profiles into the same number of equal parts, as indicated by the small figures. From the points thus obtained in F drop lines vertically, meeting the profile of the ball, as shown from C to F. From the center E of the ball erect a vertical line, as shown by E F. From the points in C F already obtained carry lines horizontally, cutting E F, as shown, and thence continue them, by arcs struck from E as center, until they meet corresponding points dropped from the profile F' by lines parallel to the gable in elevation. Through the intersections thus obtained trace a line, as indicated by G H. Then G H will be the miter line in elevation. At right angles to the gable lay of a stretchout of the profile at any convenient place, as shown by P R, through the points in which draw the usual measuring lines. Place the T-square parallel to the stretchout line, or, what is the same, at right angles to the lines of the gable, and, bringing it successively against the points in the miter line G H, cut the corresponding measuring lines. Since the surface against which the two mouldings mitre is that of a sphere, the pattern representing the space between the points 1 and 2 of the profile, and also between 7 and 8 of the profile, will necessarily be an arc of a circle. Therefore in the pattern the line running from S to U, and also the line from V to T, must be struck from centers which are to be found. By inspection of the elevation, it will be seen that the space S U is equal to that of D G struck from the centre E. Set the dividers, therefore, to E D or E G of the elevation, and from S and U respectfully as centers, strike arcs, which will be found to intersect at N. Then N is the center by which to describe the arc S U. By further inspection it will be seen that the lines corresponding to 7 and 8 of the stretchout meet the profile of the ball at M. Continue this line indefinitely in the direction of K. From E, at right angles to it, draw the line E K. Then K M is a radius of the arc to be described from V to T. Set the dividers to K M, and from V and T respectively as centers, strike arcs which will intersect in the point O. From O, with the same radius, describe the arc V T. Trace a line through the points from U to V. Then S U V T is the pattern for the gable moulding to fit against the ball, as shown.

THE telephone has been successfully worked over a distance of 350 miles between Buffalo and Patterson in New York and New Jersey States. The voice could be recognized, but owing to the sputtering and snapping caused by induction (the wires were close to the ordinary lines), the words could not be distinguished. The experiments were made to test a method of adjusting the battery-power devised by Mr. Noonan, manager of the Paterson Telephone Company, and were deemed highly successful.

"JERRY" building has thus been defined: Joshua, the son of Nun, walked round Jericho in the old time and caused trumpets to be blown, whereupon the walls fell with such facility that the builders thereof were greatly blamed, and their work became proverbial. No more odious epithet henceforward could be laid upon a builder than to be called a "Jericho builder," or, as the name has, in the progress of the ages, been corrupted, a "jerry builder.

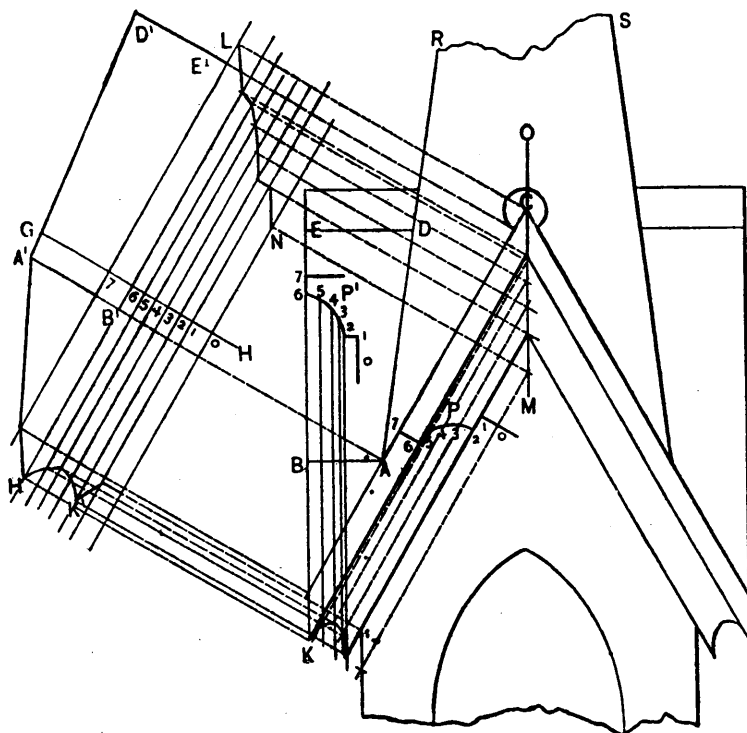

Cornice Miters.—Fig. 18.—Patterns for the Moldings and Roof Pieces in the Gables of a Square Pinnacle.

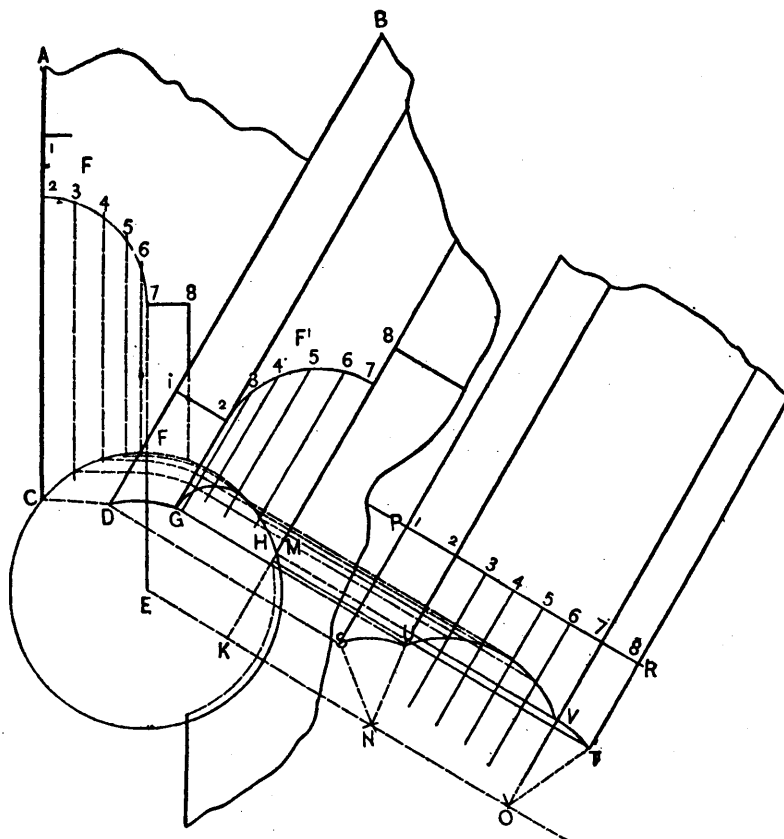

Cornice Miters.—Fig. 19.—The Pattern for the Miter Between the Moldings of Adjacent Gables Upon a Square Shaft, Formed by Means of a Ball.



Fig. 1.—A Narrow Panel Out in Pine.

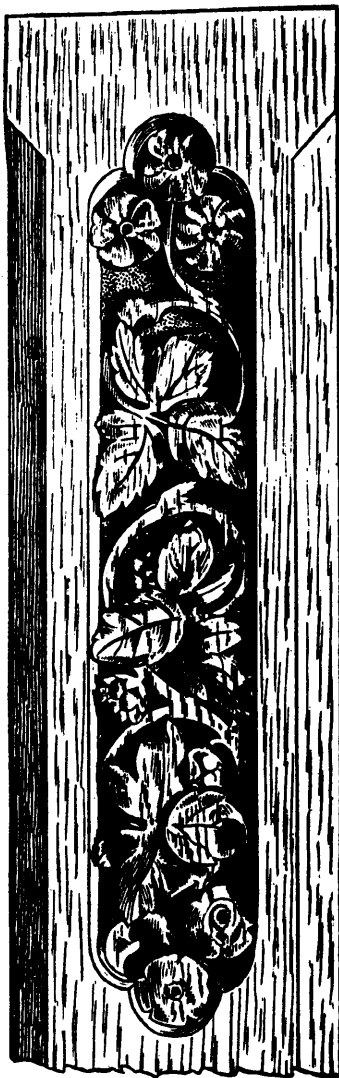

Fig. 2.—Small Panel in Oak—Lower Half in an Unfinished State.

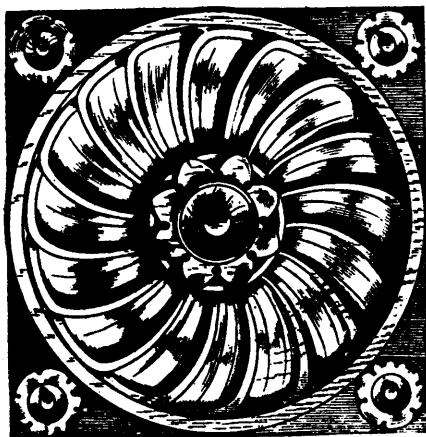

Fig. 3.—A Rosette or an Ornament for a Small Pane

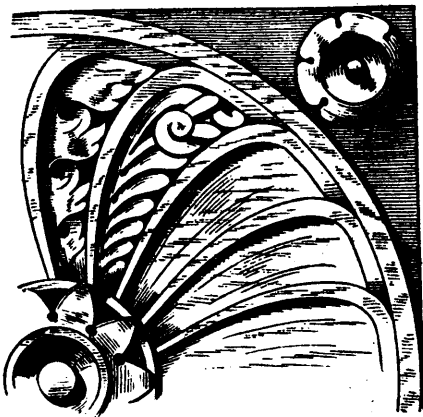

Fig. 4.—Part of Rosette Shown in the Preceding Figure, Enlarged.—Two Modifications of the Design are Shown.

SUGGESTIONS IN WOOD CARVING.

SUGGESTIONS IN WOOD CARVING.

Pattern makers in stove works are interested in the subject of wood carving, whether it be treated in its special application to their trade or in a general way. The following article from the pen of Mr. W. E. Partridge, which appears in the September issue of *Carpentry and Building*, and which follows in regular sequence the articles upon Modeling in clay already published in those columns, will not fail of interest to the class named.

The beginner in wood carving who has followed our articles, has doubtless felt the need of some examples of work suitable for his purpose other than those we have given. In this article we present engravings of some wood carvings made by very skillful men, especially to illustrate leading features of simply carved work. Fig. 1 represents a panel 2 inches wide by 14 inches long. It is carved in pine, and the greatest depth of the background is scarcely $\frac{3}{8}$ inch at the deepest point. None of the work reaches the surface. These figures show that it is unnecessary, in order to obtain strong contrast, to seek for very high relief. The method of handling the surfaces, of bringing projecting parts against deep hollows and of placing one part over another, is sufficient to give all the contrasts which are shown in the engravings, without the necessity of cutting the wood away to great depths, this shallow work being even more striking in the wood than is shown in the cut. The stems in all this work were first cut rectangular in section and then finished with a gouge having a very small sweep; this, while leaving the corners sharp, so as to catch the light and make strong shadows, admirably imitates the general effect of the bark. This example, drawn on a considerably larger scale, would form an admirable lesson in modeling, giving, as it does, a very pretty theme for a panel, and at the same time allowing the student an ample field for displaying his knowledge or his skill of hand. It is, of course, impossible, in an engraving printed in an ordinary press, to give an idea of the beautiful effects obtained by the cutting tool in the soft wood, and that, too, in the simplest manner and with little labor. Fig. 2 is a small oak panel, in which the greatest depth is $\frac{1}{4}$ inch. The panel is the same width as that first mentioned, but not quite so long. The reader will notice that the lower half of the design is unfinished, showing the work as it was blocked out. The upper half is complete. The two little flowers at the bottom are scarcely more than buttons, yet they are in the condition of half-finished work and show how results are to be obtained. All the stems in the lower portion are rectangular, and the forms of the leaves are given and their outlines corrected, but there is no attempt made at the veining. The stems of the upper portion are finished by cutting a chamfer along their edges, and in the chamfer making a score, so that the finished work, when closely examined, appears as though a V-shaped tool had been run along so as to cut out the corner. In finishing the leaves, one-half is made higher than the other at the centre line, so that according as the light falls, we have the effects of a raised or sunken rib. The smaller ribs are formed by sharp V-shaped cuts and by raising the surface on one side above that of the other. The workman was evidently a master, for he has made his tool mark useful in indicating curves on the surfaces. The light veins upon the leaves and many other skillful matters of this sort must be seen rather than described, but the carver will find out many of them for himself after a little use of his tools. One thing must be borne in mind—that on work of this description sandpaper must not be used. Many men are so accustomed to see dead, smooth surfaces on carved furniture and other work of the kind, that they have an instinctive tendency towards smoothing up everything to which they can apply a piece of sandpaper. This destroys the character of the work, and makes it appear as though it were made of putty. In the best work the tool marks show, and show to some purpose.

The original rosette from which Fig. 3 was taken is $5\frac{1}{2}$ inches square, and the projection of the centre above the back ground on which the small rosettes are carved is only $\frac{1}{8}$ inch. In looking at it, it is difficult to believe that so good an effect has been obtained with so small a projection. The leaves radiating from the centre rise; then with long sweep, slope outward, and, finally, rise again just inside of the circle. This design, while very easy to make in wood, would be unnecessarily difficult in clay, and we should not advise any one to attempt to model it. It can be laid out with the compasses and lead pencil upon the surface of the wood and work commenced at once.

One of the great beauties of this ornament is its suggestiveness; it is hardly possible to look at it without seeing in the mind each of the leaves filled with a variety of complicated work, as illustrated in Fig. 4. If the student wishes some practice in wood carving he cannot do better, after having had the

practice which we have indicated in our previous articles, than to take a block of pine, and, drawing any one of these designs upon it, attempt to carve it. In doing this let the design be first outlined with a narrow chisel, sharpened like a knife blade from both sides. When the outline has been incised to perhaps the depth of $\frac{1}{8}$ inch, cutting away may be begun. The other steps need not be described, as to any one accustomed to the use of tools this would be superfluous, and our remarks have been directed to those who are already familiar with the handling of wood and the use of tools.

PAINTING PAPERED WALLS.

Paint will not answer on walls if the pattern of the paper is not prepared with sand paper. See all places are sound, then procure a flat piece of cork, fold a piece of sand paper round it, and paper every part to make level, then give it a coat of patent size; when dry, rub smooth again. Then mix the paint with gold size. The principal thing in painting, varnishing or graining, is to have a sound wall to work upon and as smooth as possible.

Another writer gives the following instructions:—

This will only answer when the paper to be painted is a flock one. Then the effect is very good, having the appearance of stamped cement. The flock paper should be well brushed over and cleaned from dirt before painting upon it, but it requires no other preparation, being sufficiently absorbent to take up all the oil. The paints used are the ordinary house paints. Five coats of paint are necessary, each coat allowed time to thoroughly dry before the next is applied. The drawbacks to this kind of decoration are the expense of the five coats of paint, the liability of the paint to chip off when finished if roughly knocked against, and the accumulation of dust in the deeper parts of the molding, but the effect is very good indeed, and where the household does not number many children, is highly to be recommended. Sizing the paper before putting on the paint is not good, although painters, to make a job, sometimes do it. Unpapered walls will first require a builder's opinion upon them as to whether the plaster that they are made of is fit to receive oil paints.

Should his opinion be favourable, the first coat is laid on, which is a "priming," and intended to stop the absorption of the plaster. This priming is made of white lead and red lead, mixed with one part of turpentine to three of linseed oil, and a small proportion of patent dryers. When this coat is dry it is rubbed smooth with sand paper, and all nail holes, etc., stopped with putty or white lead. The second coat is as the first; this, when dry, is rubbed over with sand paper. The third coat is made with regard to the finishing color. White lead, tinted with powder color of the shade desired is mixed with linseed oil, turpentine and patent dryers, the oil and turpentine not quite in equal proportions, but nearly so (turpentine being the least). When dry and rubbed down, a fourth coat is needed, made of equal parts of oil and turpentine, with the tinted white lead and dryer as before. The fifth coat is the "flattening"; it is composed of pure white lead, tinted as to color, and diluted with turpentine alone. The dryer is either the patent or some japaners' gold size. The last coat is applied very quickly and carefully, as the turpentine evaporates, and the work must be done without a fault, as any retouching or going over will leave an indelible mark. The painting of a large interior wall is a difficult matter for an amateur, and should not be tried until a good deal of other painting has been mastered; but wainscots, doors, window sashes, are all within his compass. In all cases it is advisable that the paints should be bought mixed, as so much time and paint are wasted over getting the shades to match by any one not acquainted with the process.—*American Cabinet-Maker*

ELECTRIFIED CLOTH.—In a wax-cloth manufactory at Griesheim, near Frankfort, the finished pieces of wax-cloth are hung up to dry in an artificially-heated room, being supported in successive folds on wooden bars placed across near the roof, and the lower parts being about a yard above the floor. The air is kept about a day at the temperature of 40° to 60° C. by means of the furnace gases passing through earthenware pipes in the ground, but also and especially, an air-current heated by these. On opening the place, (the heat having been shut off for a short interval), the wax-cloth is found strongly electric. The boys go under to have their hair set on end, and a distinct shock is received on touching the cloth, more or less strong according to the size of the piece. The explanation, as Herr Krebs says, is doubtless to be sought in friction by the hot air on the wax-cloth in its rapid passage through the room.

Architecture, etc.

INTERNATIONAL ARCHITECTURAL COMPETITION AT ST. PETERSBURG.

The Royal Institute of British Architects has received a communication from Lord Tenterden, stating that British architects are invited, in conjunction with those of other nations, to join in the competition for a church at St. Petersburg, to be erected on the site where the late Czar was assassinated. The more salient of the conditions of the competition, as given in the *Journal de St. Petersburg*, are appended:—

In pursuance of a resolution passed by the Municipal Council of St. Petersburg to erect a stone church, dedicated to the Russian Orthodox Ritual, and to be sacred to the Memory of His Majesty the late Emperor Alexander II., a competition is opened for the design of this edifice, under the following conditions, viz:—

The design must be so arranged that the church has three altars, the spot where His Majesty the Emperor fell mortally wounded (shown on the plan by a cross) may stand in the centre or at the right angle of the western part of the church. This spot may be considered as treated as constituting the object of an annexed part of the edifice, though it must nevertheless form one and the same connected design of the church as a whole.

The foundation line of the west elevation of the church must not advance into the bed of the canal to an extent exceeding 7 ft.

The church must be designed to hold a congregation of 1,000 persons, upon the principle of allowing 7 ft. square to every 16 persons.

The position of the tower or that part of the building which is to contain the bells, is left to the choice of the competitors.

Competitors are required to submit designs for the ornamentation of the bridge, which is to cover part of the canal so as to form a square in front of the church; and of the ornamentation of the part of the Palais Michel which will surround it.

The designs must include detailed plan of the church, two elevations, one a lateral one and the other facing the park, and also a section; these drawings to be prepared to a scale of one inch (English) to the *sagène* (7 ft.)

The west elevation and another section must be drawn to a scale of two inches (English) to the *sagène*. A general plan, on the scale of one inch to five *sagènes*. A perspective view of the church with its approaches. An explanatory memorandum stating among other details the cubic capacity of the church, computed in *sagènes*, and describing the nature of the materials to be used in the construction.

The designs must be submitted at the office of the Municipal Council of St. Petersburg at the latest on the 31st of December, 1881 (12th of January, 1882), at noon.

The general plan of the site whereon the church is to be erected may be had on application to the *Gérant* of the Town Hall of St. Petersburg.

For four designs sent in by the appointed time, which fulfil the conditions laid down in the present programme, and are allowed by the jury to be the best in order of merit, the Municipal Council will grant four premiums. For the first in order of merit, 2,500 roubles; for the second 2,000 roubles; for the third 1,500 roubles; for the fourth, 1,000 roubles.

All designs must be sent in in a portfolio, and not rolled up in a case.

Every sheet of the drawings, as well as the explanatory memorandum, must bear a motto chosen by the author of the design.

All the designs sent in will be exhibited to the public during eight days in the Town Hall.

The jury undertake to publish a short Memorandum setting forth succinctly the merits and defects of all the designs presented. The names of the premiated competitors will be published.

The prize designs will become the property of the Municipal Council of St. Petersburg. The designs not selected for the prizes will be returned.

Members of the jury are debarred from participation in the competition.

The premiums awarded will not entitle the successful competitors to take part in the construction of the church. The committee appointed by the Town Council reserve to themselves the selection of the architect.—*Building and Engineering Times*.

Brockton, Mass., now manufactures more sewing machine needles than all Europe combined. They are turned out by the million and shipped all over the world. The needle made of the best steel, passes through thirty different hands in its manufacture before leaving the factory.

A NEW PAVING MATERIAL.

The International Pavement Company, which has been for some time in existence in the United States, having succeeded in obtaining the permission of the City authorities to have a portion of Queen Victoria Street with their new materials as an experiment, the work performed was submitted to the inspection of a number of persons interested, at the end of last week. The plan adopted by the company is to lay four inches of concrete bed, and over this an inch of sand, to form a cushion for the blocks. The blocks themselves are rectangular, and measure about 12 in. long, 5 in. deep, and have a 4 in. face. In composition they consist of a combination of bitumen, lime stone, and a little oil, and in the process of manufacture they are submitted to a uniform pressure of fifty-six tons in a steam press. These blocks are laid on the sand cushion in identically the same manner as are wooden bricks, the joints being filled in with hot sand for the purpose of keeping the water out. The site allotted for the experiment is an area of about 500 square yards at the portion of Queen Victoria Street which flanks the Mansion House Station, and is the only situation apportioned in London for the purpose. In regard to durability the blocks have every appearance of being able to stand the hardest possible wear, and the general manager, Mr. William J. King, states that some of the busiest thoroughfares in Philadelphia, being laid with them, have not been repaired for seven years. The company guarantee that the new pavement is free from the noxious exhalations which arise from wood, and that it has a resisting power against heat, cold and moisture. As the traffic passed over the road the horses appeared to have a firm foothold, and there was but very little noise. In cost it would be cheaper than granite and about the same price as wood paving. The company hope to achieve a wider sphere of usefulness for the blocks by using them in culvert and tunnel building. Messrs. Blyth and Co., 17, Gracechurch Street, are the London agents.

MODEL HOME.

On the next page we present to our readers a picturesque pair of cottages, consisting of six rooms each, designed by R. Rosenstock, architect, 173 East 125 street, New York. The first story of the house is weather-boarded, on the balance shingled and painted red; the second story front room has corbelled out a bay window, the upper portion of sash being of stained glass. The roof, where expense is not an object, might be slated, but can be shingled and painted to imitate slate.

Reference to the plans will show of what size the cottages are. The first floor consists of a good sized parlor, staircase hall, (stairs and hall to be of hard wood,) dining room with octagon bay window attached, (a feature of this room is a large open fireplace) and a good sized kitchen fitted up with range, boiler, sink and china dresser, and if desired wash trays can be put in without much expense. A small verandah is attached to the house in front. To the cellar which is of the full dimensions of the houses, we have access by stairs under the main ones. The upper floor has one large front and two smaller bedrooms; the front room has a bay window projecting eight inches, this room also has a large closet attached. The cottages are intended to be finished in a good and substantial manner, the interior finish to be pine except the hall which is hardwood. The whole throughout to be plastered, the finishing coat being a light gray sand finish, ceilings white with neat stucco cornices in the parlor, dining-room, hall and two main bedrooms. This, together with the small amount of stained glass, produces an effect seldom to be met with, and comparing favorably with houses of more pretentious design and finish.

These cottages, under favorable conditions and locations, can be built for \$2,000.—*Architect and Builder*.

SINGULAR PROPERTY IN STEEL.—It is well known that a steel that is very flexible when cold breaks at the blue annealing temperature. It has generally been considered that the purer the iron is the less subject it becomes to this defect; but the workmen of the Ural Mountains who use iron of remarkable purity, have often observed the same fact. Mr. Adamson has found that the metal becomes powdery at a temperature between 260° and 370° C. (500° and 698° Fah.) or the temperature at which willow twigs take fire. This phenomenon seems to explain a large number of accidents, as, for example, the breaking of tires under the action of brakes and the friction of riveted moulds and of machine arbors which become heated by friction.—*Ann. du Gen. Civ.*

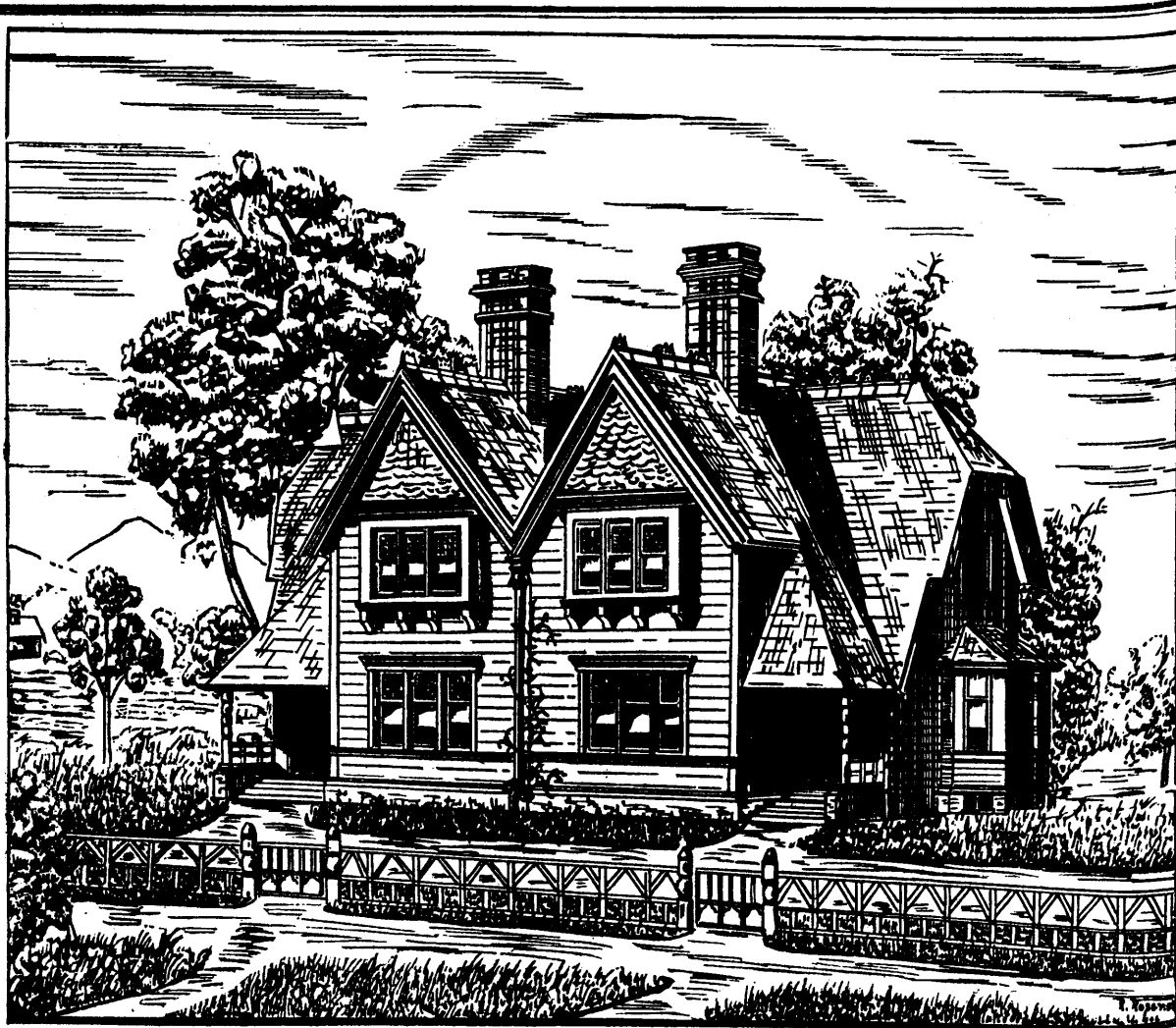

DESIGN FOR TWIN DWELLINGS, COSTING \$2,000.

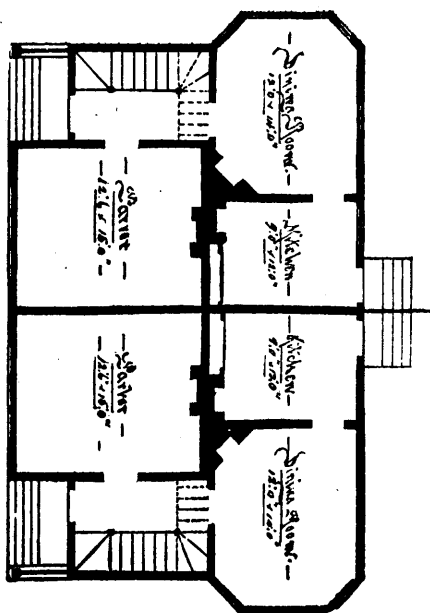

First-Floor Plan.

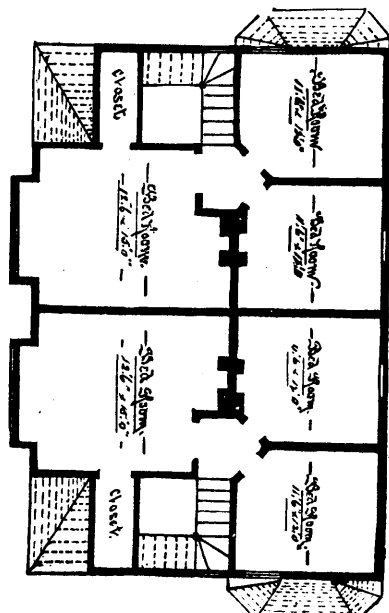

Second-Floor Plan.

MODEL HOME.



GRAND ENTRANCE TO THE INNER COURT, BURLEIGH HOUSE, NORTHAMPTONSHIRE.

BURLEIGH HOUSE, NORTHAMPTONSHIRE.

The present Burleigh House owes its existence to William Cecil, Baron Burleigh. He says: "For the building there, I have sette my walles on the olde foundations. Indede, I have made the rough stone walles to be square, and yet one side remaineth as my father left it me." We may digress for a moment to say that Burleigh House was not the only mansion erected the Cecils. Hatfield House, in Hertfordshire, was reared by Robert, son of the Lord Treasurer, and first Earl of Salisbury; and Camden, describing Worthorpe House, about two miles to the west of Burleigh, and now in ruins, says that it was a mansion of considerable size, erected by Thomas Cecil, who jocularly said he "buit it only to retire out of the dust while his great house at Burleigh was sweeping."

Burleigh House is in the centre of a magnificent park, some mile and a half from Stamford. This park was formed when the house was rebuilt, and through it a great avenue leads to the mansion, which forms a vast quadrangle, surrounding a court: to the east are the great hall, the kitchen, various domestic offices and the stables, &c.; and this portion of the edifice is (subject to alterations and modern additions to a large extent) the part of the ancient structure probably alluded to in the letter already quoted. The northern side has a noble front towards the avenue, and with the southern and eastern portions forms the palace commenced about 1575, under the direction of John Thorpe, who was considered the architect.

Several additions and many alterations have been made by successive Lords of Burleigh, and this magnificent seat is now, with its vast suites of rooms, its painted halls and chapels, its wonderfully carved work by Gibbons, its tapestries and richly embroidered hangings of silk and velvet, its marble decorations, its galleries of painting and sculpture and varied collections of works of art, its broad acres of wood, field, and flood, its pleasant gardens, and prospects far over the counties of Rutland, Leicester, and Lincoln, scarcely second among the princely mansions and domains in England.

We give, in illustration, a representation of the grand entrance to the inner court; the gates are excellent examples of metal work, of admirable design and workmanship; and the crest of the Earls of Exeter—a wheat-sheaf supported by two lions rampant—is skilfully introduced into the ornamentation.

THE BEST MATERIAL FOR PAINTING TIN ROOFS.

Some time ago we wrote an article upon the subject of painting tin roofs and the best materials for the purpose. In various forms it has been going the rounds of the technical press ever since, and recently it has made its appearance with a few modifications in the columns of a paper published in San Francisco. It has in some quarters received unfavorable criticism, and in one of our exchanges we find the following, which is from a prominent paint manufacturing company. Though not perfectly intelligible in all parts, we give it entire, as we wish to criticise the greater portion of what the writer has to say in regard to the use of iron for painting:

"*Editor of Oil and Drug News*; In your issue of June 7 you copy an article headed "Paint for Tin and Iron Roofs," from the *California Architect*, which has since been inserted as 'original matter' in other papers, and currency is thus given to statements which are so erroneous that they should be corrected. The writer begins by asserting that—

'All fine preparations of the carbonates and oxides of lead or copper are unsuitable for painting tin roofs, for the reason that a pure oxide, when applied to other metals, will assist in the action of the elements to oxidize the metals they cover. The vehicle of all good paint is boiled or raw linseed oil, and this, when thickened with pigments, covers a less given space; and the material being an oxide, holding more oil than is imparted to the surface to be painted, soon throws off its share, and is ready to absorb the air and convey it to the body of the metal, where natural corrosion will take place, and then the two oxides unite chemically. In other words, all paints, in the absence of a solvent, which time soon releases them of, act upon iron or tin as a filter, feeding the porous spots with moisture, like a porous plaster of rust; and as like produces its kind, the decomposed metals work like a happy family and roll in beds of rust. This fact is observable on flat surfaces, or in gutters where inequalities occur. Here the fine dust or powder collects and keeps the water in them until the oil is decomposed; then the work of oxidation commences.'

"There is a certain amount of fact in this statement, viz.: 'That all fine preparations of the carbonates and oxides of lead

or copper are unsuitable for painting tin roofs.' This has been known and acted on for more than 20 years, and the use of such oxides and carbonates upon tin abandoned, not for the reason given, but partly on account of the cost being great and partly because a better and cheaper article has been produced, especially for this class of work, containing a large proportion (72 per cent.) of the oxide of iron and a natural drier that will cause the paint to harden the more it is exposed to the weather. The oxide of iron in this paint has reached that condition by being kept at a cherry-red heat for 70 or 80 hours, while at the same time exposed to a current of air until the last possible atom of oxygen has been absorbed. After this, no further chemical change can take place by exposure to either fire, air or water, and the paint having a natural affinity for metallic iron (of which both iron and tin roofs are made), combines with it and forms a coating when the oil has dried that will completely arrest and prevent corrosion. Metallic paints (so called) that are made from crude oil on the other hand, will act precisely in the way described by the California writer. In that case, when the film of oil is worn away from the surface, the raw iron acts as a medium to convey the oxygen from the air to the iron (tin) beneath to rust and destroy it. The writer further says:

'The best paint for tin or iron is composed of pure linseed oil and earthy ochers, red or yellow. The coarser granulated powders are best as a pigment, as they offer less air holes and give a firmer hold for the oil on the grits, and thus bend them to the metal. The oil in this manner gets close to the metal, and offers resistance to the air in removing the atoms from its cohesion.'

"The use of ochers for painting tin roofs has been given up long ago, for the reason that they are nothing but clays of different colors, soak up oil like a sponge, and afford no protection against rust. The idea that 'coarse granulated powders are best' is decidedly rich. Why not use without grinding at all? If this is true, the coarser the 'powders' the better, and, perhaps, even a coating of varnish to hold the 'grits' fast would be a good plan. It looks very much as if some one in California had a lot of gritty ocher to sell, and thought that if it was put upon tin roof where no one could see it, that would be a good place to put it. People who are not 'architects,' who do not want their tin roofs to rust, will still continue to use finely ground metallic oxides made from iron, especially when a paint is made from this material, that will harden under water, that is durable, cheap, and has been tested for over twenty years, may always be had."

The erroneous statements are those made by the writer of the article, and not those which he quotes. Contrary to the generally prevailing opinion, the value of paint as a protecting coating for iron and for wood also depends entirely upon the oil, or at least to such an extent that we may neglect the influence of the pigment. When linseed oil is exposed to the air it absorbs oxygen, becomes thick, and finally forms a tough varnish. This varnish alone gives protection. In most cases the additions made in the form of lead, iron oxide and ochers have comparatively little to do with the quality or durability of the varnish. We cannot, however, undertake to discuss the subjects of paints in general, but must confine ourselves to those suitable for roofs.

Lead and zinc were abandoned because of their injurious action upon the tin. That this action is severe is proven by a vast amount of testimony. Cost had nothing to do with the matter, except as it influenced the profits of the "metallic paint" dealers. Probably there is no pigment known of which oil will carry so great a body as iron oxide, and for this reason the paint ready mixed can be sold at a large profit. It is about as ugly in color as it is possible for a paint to be, and the only plea that can be urged in its favor is that it contains so little oil, and is so much like sand that it does not take fire or burn readily.

The highly scientific portion of the article which takes up the subject of iron-ore paint is nonsense in more ways than one, yet it contains just enough of truth to make it pass as correct.

There are certain substances, like manganese, litharge and oxide of iron, that are so-called "driers." That is, they cause linseed oil to harden rapidly; in other words, they act upon it in such a way as to make it absorb oxygen from the air and become hard like a gum or resin. So powerful is this attraction of oil for oxygen that it will, under some conditions, partly decompose the oxides of the metals, as, for example, when mixed with lime, &c.

There are the most serious objections to the use of any oxide of iron as an ingredient of a paint for iron. None of the red or brown oxides of iron are stable. Even when combined with the greatest amount of oxygen which they can take up, they are by no means unchangeable in character—at least, not in the pre-

sence of metallic iron. It is found when an oxide is placed in contact with metallic iron that vigorous rusting goes on underneath it. The oxide parts with a portion of the oxygen, which attacks the iron, and then a new portion is absorbed from the air or any other substance containing oxygen with which it may be in contact. The oxide itself plays the part of an acid, destroying the metal on which it is placed. In fact, when iron once begins to rust, there appears to be no method of arresting the destructive action until it has been made perfectly clean and free from rust. Then a protecting coat will be of some service.

When we cover iron with oil paint the same action goes on as before. The iron rust under or in the paint absorbs the oxygen from it and gives it to the iron below. The oil, as it hardens, draws a new supply from the air. These operations continue until the iron is destroyed. They do not cease, even when new coats of paint are applied.

When oil hardens or dries by exposure to the air, the varnish thus formed is gradually converted into a gum by the continued progress of oxidation. This gum at last loses its cohesion, and in time is washed away by the action of rains and moisture.

It is easy to see, therefore, that the use of iron ore or iron oxide in a paint intended to cover an iron surface of any kind is bad. Aside from its hideous color and its objectionable chemical features, there is still another reason why it should not be used, and that is the quantity of it which a given amount of oil will carry. The fact that it is possible to put a greater body of pigment into a given quantity of oil, has been urged time and again as an advantage. Yet it is entirely against it.

Contrary to the general opinion, we should not strive to use the smallest possible quantity of oil, because it is the oil in which we have our protection, and not in the coloring matter which it holds. Some of the oldest and most experienced painters in this city believe, and found their belief in experience, that the smaller the admixture with the oil the better the paint will be for roofing. Upon this idea they mix their roofing paint, and use only so much color as is necessary to obtain a pleasant tone. The body of the paint then consists entirely of the oil.

By the so-called process of boiling, linseed oil is caused to harden with great rapidity, and on this account many persons prefer to use it for covering roofs. This is wrong. Raw oil only should be used on roofs, as the slowness with which it absorbs oxygen and becomes hard is in its favor. Here we may speak of the "porgy," "menhaden," or fish oil. This is a fat oil and hardens but slowly, and though usually considered an injurious adulteration, seems to us to have rather a good than a bad effect when added to raw linseed oil which is to be used on roofs. If a small quantity is used, the tendency is to retard the hardening of the oil and thus prolong its life. We do not know of any harmful action.

We think the reason that the ochers or "clays," as the writer calls them, were given up so long ago, was because they were not profitable, while the contrary was true of paints made from the ore and oxide paints. It must be understood distinctly that the iron oxide paints, and the "metallic oxide" paints, upon which so much stress is laid, act chemically in the same way, and when the author admits that the iron ores do act as described, he must remember that there is no chemical difference between them and the metallic oxides save that of purity; their chemical action upon the iron is identical.

We see no reason for the long-continued use of the iron paints in any form or for any purpose. They are ugly beyond all reason, and certainly for roofs there are none that can be recommended. We know nothing of their value when applied to wood, but do not have a high opinion of them. We believe it is true that some of them will harden under water, but we do not learn that this compound is water-proof, durable or capable of preventing iron from rusting. We judge that it is merely a coating of iron oxide cemented together by a rusting or oxidizing process. If these paints were half as good as they are claimed to be, there would be no further necessity for seeking the means of keeping iron from rusting. That they do not answer the purpose is attested on all sides. They are largely used, yet the iron rusts. The facts are a sufficient answer to the claims.

THE destruction of most of the town of Rinsk, in Russia, by fire, took place recently. It is calculated that nearly the whole of Russia is burnt out every twenty-five years. Of course, says the *Porjadok*, the peasants build their houses worse and worse every year, and hence the risk of fire continues to increase.

Natural History.

GREAT CORAL WORM, AND HOW CORAL REEFS ARE BUILT.

BY C. F. HOLDER.

The process of reef building is an interesting one. We will suppose that the sea bottom is first visited by a single egg from the astrea, a small delicate speck of jelly. In a few days this has begun to show a few tentacles, and is apparently, if we should examine it, nothing more than a sea anemone; but, in a few weeks, while the *polyp* has been establishing itself, it has also been secreting a little lime at the bottom of its tube, and fastened itself thereby to the object that it may have fallen upon, perhaps a clam shell. Now there will soon be seen a growth of lime upon the edges and sides of the *polyp*; it loses its likeness to a sea anemone, and is covered by a white jagged coating of lime. Soon another one is growing out alongside of the first, and the animal is capable of sending forth eggs as well. The single astrea has now become two by the process of growth much like that of the branching of vegetables, and this goes on indefinitely, while some species seem, after a time, to attain a definite form, and are thus a valuable element in the great work of building a continent. Besides the actual bulk which the stony astreas add to the work, there are many other forms which are brought in accidentally, and somewhat dependent on the first. When the bottom has become covered by the coral rock, there are numerous causes to reproduce a decay of the *polyps*. When these are dead, the pores of the coral are filled up by sand, which adds a little to the height; other corals grow upon this, and the natural *débris*, which is always swaying about by the tide, is deposited here as well as elsewhere; then there are branching corals, which take root here, and gorgonias, or sea fans and feathers. To make the reef solid and compact, nature grinds up the corals, disintegrates them, and the soft parts sift down, solidifying the entire mass. One of the great helpers in this work is shown in the accompanying engraving of a monster worm. It is a coral parasite, and a terrible one. The writer has watched it slowly crawling up the branches of the madrepores, until the end of one was reached. Its mouth, which is a sort of bag, envelopes the end of the branch, the worm slipping over it like a glove on a finger, covering hundreds of the delicate *polyps* and sucking them out of their cells. When it has exhausted the supply it withdraws, leaving the branch as white as snow, in strong contrast to the rich brown of the others. This is done continually, and the bleached branch is soon broken off and falls to the bottom to help in the general growth of the area.

Myriads of other worms wind in and out among the astreas. Of them Coryell says:

"The nereis is nothing but a series of rings from head to tail, but it is more gorgeous in color, fairly blazing with iridescent tints. It lives in holes in rocks, or in hollows of sponges or shells.

"To get about with, this worm has many little paddles, two on each ring of its body in fact, which move so fast that we can scarcely see them, and of course carry their owner very rapidly through the water. A nereis of four feet long has seventeen hundred paddles to carry it along. Besides this, there is another use for these paddles—they carry the worm's weapons. At the end of the ores are often seen what look like hairs, which are capable of being pushed out and drawn in. Looked at by the help of the microscope, these simple-looking hairs turn out to be a wonderful array of weapons—darts, curved double-edged swords, sabers, harpoons, broadswords, fishhooks, lances with barbs, and almost every sort of cutting blade. All these instruments of war, when not needed, are drawn back into sheaths in the little paddles, and so kept safe and ready for instant use. But this is not all: in each ring of its body are also tufts of branching filaments of bright red colour, which are really gills, by which means it breathes. The nereis lives upon animal food, yet its mouth is a simple opening without teeth. Beyond, or back of it, is a sort of a bag, of large size for the worm, lined with sharp horny plates, or teeth. When the creature sees its prey it sticks this bag out of its mouth, inside out. The teeth are then thrust into the victim, and the bag drawn in, still holding on to what it has seized. The prey thus swallowed is eaten at leisure."

Late shells bore into astreas, so that solid appearing heads are often found to be mere shells. The holothurians prey upon the corals, and we have often found several ounces of ground coral in the long intestine of the *Holothuria florida*.

Another enemy of the branch coral is the great parrot fish. Its jaws are composed of solid pieces of bony dentine, and it

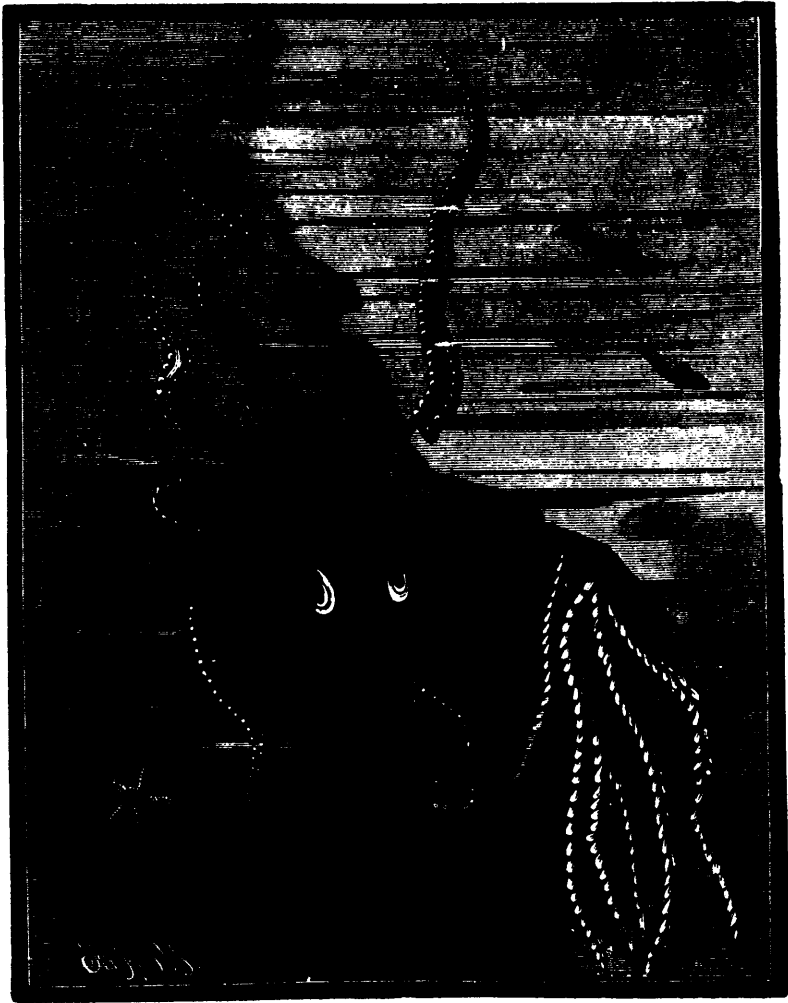

THE OCTOPUS.

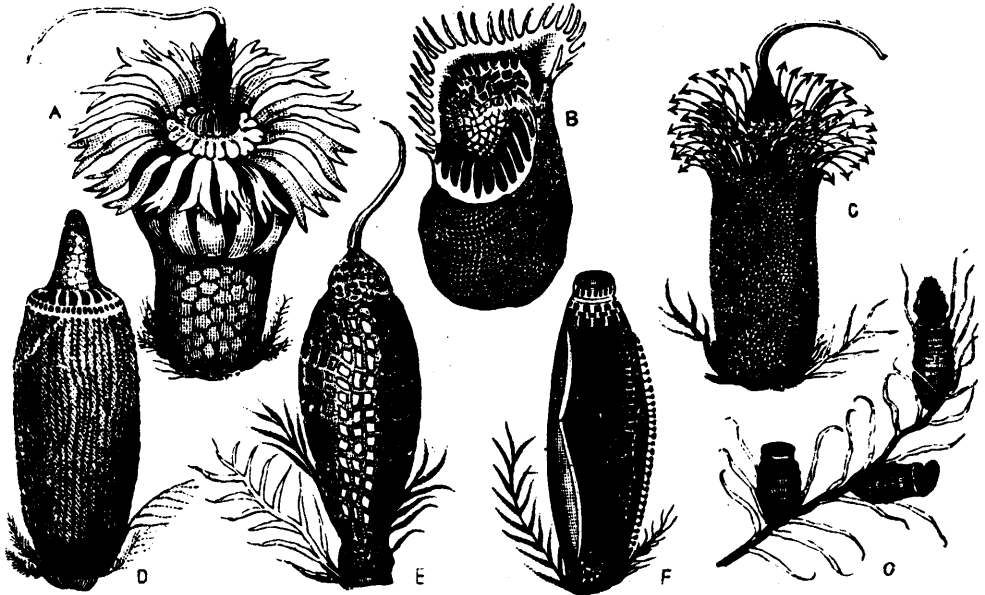

EGGS OF BIRD PARASITES.

A. Parasite of Black-winged Peacock.—B, Ground Hornbill.—C, Australian Mallee Bird.—D, Common Hornbill.—E, Golden Pheasant.—F, Crowned Crane.—G, Showing how the eggs are fastened to a feather, with a parasite issuing from the egg at the expiration of two days.



A CORAL PARASITE.

easily breaks off the tips of the coral, grinding them up and rejecting the limy portions. The entire genus (*Scarus*) are essentially coral destroyers as well as reef builders.

EGGS OF BIRD PARASITES.

Among the little bird parasites are to be found the most extraordinary and fantastic structures.

The eggs of one of the species which infest the ground hornbill so much resemble the cells of some of the polyzoa that, deposited as they are in close contact one above another, and in many parallel lines between the flattened barbs on the inner surface of the feathers, they appear like some new species of sea-mat.

The strangely formed eggs found on the Australian crane are arranged in a similar manner, and a slide containing several rows of these eggs is a fine sight under the microscope.

On one species of crowned crane (Balearica) are found eggs having a thick calcareous wall, being covered, as it were, with little white domes. Each of these projections appears to be deposited around and supported by a short spine proceeding from the shell of the egg, and supported by a sub-quadrant, pellate disk.

The egg of a parasite of the Australian mallee bird resembles somewhat the ripe fruit of the corn blue-bottle flower. The spines on the lowest or outer row on its summit are ornamented by little anchors, very like those of the *Spicula synapta*.

All these interesting eggs are, however, altogether exceeded in beauty by those of the Indian black-winged peacock, which are constructed so much like flowers that a botanist might amuse himself by describing every part of them in the technical language of his science.

The manner in which these eggs are deposited is also most singular. The animal attaches a mass of amorphous secretion to the inner side of the shaft of a feather, and then proceeds to construct two or three oval perforated or punctate sacs, much larger than the eggs. On and about, and in some cases buried, in these strange sacs are found the eggs in considerable numbers, the whole making a very interesting object for the microscope.

It is, of course extremely difficult to tell the genera to which the eggs respectively belong. With foreign birds especially it is almost impossible to do more than form a probable guess on the subject. The peacock has a fine specimen of *goniodes*, and the common turkey is infested by a large *goniodes* and a *liperus*. There is a remarkable species of *acarus*, described by Dr. Robins, found spinning a white silken web on the base of the sparrow's thigh, or on the forepart of its body. On raising this delicate web you perceive that it is filled with minute eggs, from which the young issue, being in due time hatched by the warmth of the body they are destined to annoy.

Perhaps this slight sketch may induce some naturalist or microscopist to pay attention to a little known page in the wonderful book of nature we are all trying to decipher.

PECULIARITIES OF THE CEPHALOPODA.

BY C. F. HOLDER.

Among the mollusks of the highest class the cephalopods have many remarkable features well worthy the close attention of a student. They are divided into two general classes by naturalists, according to their number of gills. The common octopus, and in fact all the cephalopods except the nautilus, belong to the two-gilled or dibranchiata; while the nautilus forms the only living representative of the tetrabranchiata; other divisions are based upon their number of legs—hence the octopods, with their eight arms, and the decapods (as the squids), with ten. The most striking feature in the anatomy of these animals is the brain, which is covered by a decided and distinct cartilaginous covering or cranial envelope that closely resembles the skull of the vertebrates. Furthermore, the head is distinct, and in the squids movable; the eyes large, bright, and, so to speak, intelligent; in fact, their entire composition bespeaks for them a high position in the scale of life.

The octopods, with the bag-like bodies, green eyes, and branching arms lined with suckers, are far from pleasant objects. Each arm is lined with two rows of round suckers that act like so many air pumps and hold on to any foreign substance with death-like tenacity; besides these weapons the octopus possesses an ink bag and two parrot-shaped bills of great power. They rarely swim, except one or two species that have peculiar webs for this purpose between the arms, and generally are found hidden among the dead coral of the reef or under the refuse of the bottom. Their power of attenuation is remarkable, and I have often observed them draw their entire body through an orifice that seemed scarcely large enough to admit a single tentacle. When touched, rich waves of color follow each other over the body in rapid succession, and they assume a mottled appearance. Another attack will cause the sharp eyes to glow with a baneful light, and, like a flash, a dark cloud permeates the water, and under its protection the animal makes off. Their strength is surprising. I have frequently struck them with a spear a foot and a half across, and having lifted them into the boat found it almost impossible to tear their arms from the boards after they had taken hold. The strength of one sixteen feet across can well be imagined. A story comes from the northwestern coast, which has been substantiated to the effect that a monster octopus had seized an Indian woman while bathing and several hours after the body was discovered in deep water in the arms of the monster.

Some interesting experiments made by the writer with these animals, on the Florida Reef, seem to show that they at times use their color as a protection. Ten or a dozen specimens were taken and placed in inclosures in a shallow portion of the open reef. In one, the bottom was of pure white coralline sand; another was merely an inclosed head of *Mandrina cerebro* forms, which was a brownish olive, while the third had a bottom almost black. Into these inclosures the animals were released, and the next day examination showed that they had very decidedly assumed a hue in conformity with that of the bottom upon which they rested; those on the white sand were the palest gray; those on the living coral had assumed a darker hue than usual; while those on the black bottom could hardly be distinguished. Many other animals also adopt similar methods for protection.

The octopods are oviparous, and deposit their eggs in clusters that resemble bunches of fruit, often called sea grapes by seamen. They are always deposited upon some solid substance, as shown in the accompanying illustration, hanging to a rock.

The most remarkable peculiarity concerning them is the formation of the male, who is entirely different from the female in every respect. What is generally called the male is represented in the engraving as a common octopus, but in reality he is but the parent of the real male that appears by a process of fissuration. This curious freak of nature can better be understood by observing the animal at different stages. When the breeding season arrives, the third left arm tentacle or arm of the so-called male octopus assumes a different shape. On one, the *Octopus bairdii*, it appears as a short rounded arm, as if torn off and the wound healed up and swollen; the change increases until, finally the arm is detached, and becomes itself a living organism, and swims freely in the water, being either deposited by its originator in the funnel of the female or finds its way there instinctively. When first discovered it was considered a parasite worm, and so described and named *Hectocotyl*, but later investigations have shown its true nature. Cuvier describes the hectocotyl of *Octopus granulatus* as five inches in length and resembling a detached arm of the octopus, its under surface being bordered with forty or fifty pairs of alternate suckers. Dr. Kolliker, of Messina, describes another, the hectocotyl of *Tremoctopus*, which was adhering to

the interior of the gill chamber and funnel of the *Poulpe*. The body is worm-like, with two rows of suckers on the ventral surface, and an oval appendage on the posterior end. The anterior part of the back is fringed with a double series of branchial filaments (two hundred and fifty on each side). The suckers, forty on each side, closely resemble those of the tremoctopus in miniature. Between the suckers are four or five series of pores, the openings of minute canals, passing into the abdominal cavity. The mouth is at the anterior extremity, and is minute and simple. The alimentary canal runs straight through the body, nearly filling it. The heart is in the middle of the back, between the branchiæ. It consists of an auricle and a ventricle, and gives origin to two large vessels. There is also an artery and vein on each side, giving branches to the branchial filaments. Nerves extend along the intestine, with one ganglion. The oval sac alluded to above incloses a small, but very long convoluted tube, ending in a muscular *vas deferens* containing innumerable spermatozoa.

The hectocotyl of the argonaut was considered a parasitic worm, described under the name *Tricocephalus*. It is similar to the others.

This strange method of propagation is not found among the squids; with them the male and female are alike, except a slight difference in size. The last ten years has set at rest the question as to the size of some of these animals, and from well-preserved specimens they are known to grow to a length of sixty or seventy feet. In the natural history of almost every country there are legends of the existence of these huge creatures, but it is only within a few years that perfect specimens have been found. Whalers often found immense pieces of squid in the stomachs of whales, and finally scientists made some decided efforts to obtain one of these gigantic animals. Rev. Dr. Harvey, of Newfoundland was the fortunate finder, and in a short time a number of them were secured.

The one bought by the New York Aquarium was by far the best, and Prof. Verrill, of Yale, and Dr. Holder of the American Museum, were fortunate in examining it and taking its measurements. It was afterwards ruined by being kept out of alcohol, and shrank to nearly half its original length, which was nearly forty feet. The body resembles a great gray bag, and the tail an arrow head; from the head the eight short arms branch out and the two long ones. These latter enlarge at the tips, and only these have suckers, while the short tentacles have suckers their entire length. Each of these disks contains a hard bony marginal rim, sharply serrated, that when pressed upon the flesh can be pressed into it by the piston-like arrangement of the sucker. The effect of thousands of these can readily be imagined. A peculiar arrangement is noticed on the end of the long sucker; between the rows of suckers, many of which are on stalks or pedicles, are hard callous cushions; their use is seen in the movements of the animal as it secures its prey. They move slowly through the water, and sighting their victim with their large saucer-like eyes, instead of rushing at it, the two long arms are thrown out thirty feet or more and clasp it; the use of the cushions is now seen, as the suckers of one arm clasp the cushions of the other, and *vice versa* and thus double power is brought to bear. The act can be better illustrated by tying the hands at the wrists and the use of them in this position is analogous to the movement of the squid. Once caught in these long handled pinners, the fish is drawn within reach of the eight short arms, which wind around it like so many snakes, lacerating its body and finally press the back of its head against the parrot-like beaks, which penetrate the flesh and sever the spinal cord. This method of severing the spinal cord is very general among the squids, and all the fishes that have been noticed that have been cut by them have been cut in exactly the same spot, and the most effective one, as its struggles are instantly stopped.

The power of the animal is very great. A fisherman in Newfoundland saw one lying evidently dead on the surface, and struck it with an oar and came near being a victim. The squid which was *Architeuthis princeps* ejected a column of ink and water from its funnel and threw its arms over the boat, almost sinking it. One of the tentacles caught the man by the arm, lacerating the flesh terribly; he seized an axe, however, and succeeded in severing several of them, finally sending an oar blade into the eyes and destroying the animal.

A use of the long arms has been noticed when one was thrown upon the shore in a gale of wind, and although in a heavy sea, it fastened the long suckers to the rocks and outrode the gale, swinging to them as would a ship by a hawser. The squids are undoubtedly denizens of the deep sea, which accounts for their rarity. In the later geological ages they reigned supreme among their kind, and their curious hardened ink bags are found and still used as ink.

The shelled cephalopods grew to enormous dimensions. The ammonite is found almost as large as a cart wheel; the orthoceroite, a straight chambered cephalopod, has been found fifteen feet long, and according to some geologists they occur in the Black River limestone, of a length of thirty feet. It would take a volume to even enumerate the wonders of this interesting family, whose history is written indelibly on the rocks of the primeval world.—*Scientific American*.

THE TEXAN WHITE-BACKED SKUNK.

It is so common to speak of the skunk, that many have the impression that there is but one animal to which the name belongs, while there are within the United States at least five distinct species, and perhaps nearly as many more in the adjacent Mexican territory. The White-backed Skunk (*Mephitis misonisaca*), of Texas, differs from our common species in various respects. Its body is very broad behind, and in walking it carries its head near the ground, while its back is strongly arched. One of its marked characters is its naked muzzle, which is without hairs for one inch or more from the end. Its forehead is rounded, eyes small, and ears short. The hair on the body of this species, as in all others, is black, but there is a remarkable white stripe on the back; this, as shown in the engraving, begins at the middle of the crown, and extends backwards to the tail; this strip widens on the body to include about half of the back, and narrows towards the tail, which is also entirely white. With the exception of a white hair here and there, the under parts of the body are entirely black. This species is about 18 inches in length, with a tail about 12 inches long, and weighs between four and five pounds. The few accounts of this Skunk go to show that its odor-bearing qualities are not different from those of its northern relative, and it is quite as unwelcome.—
DR. GEO. THURBER.

Miscellaneous.

A FISHING WHEEL.

A new and very destructive fishing device is reported from the Columbia River, Oregon. It consists of a jetty of rocks built out from a point on the shore of the river, outside of which is a planked sluiceway, in which an undershot wheel with large tank buckets revolves. The sluiceway was built when the river was at its lowest stage of water, and the wheel is hung so that it can be raised or lowered as may be desired according to stage of water. The instinct of the salmon is to run up the river alongside of the banks instead of mid-channel. By this the fish can take advantage of the eddies below jutting points of land. On these projecting points the Indians have from time immemorial taken salmon in large numbers by using dip nets. The jetty built out from the point above named makes a larger and longer slack water behind it, and the salmon rounding the point rush into the sluiceway to get up the river. In the sluiceway, the wheel which revolves in the current, is gauged so as to sweep within a foot of the bottom, and the salmon are scooped up in the tanks or buckets, which latter let out the water as they ascend. On the wheel descending the fish are thrown out into a trough or gutter leading to a pen below, where they remain until taken away to be canned. The arrangement of the sluice, wheel, etc., is a most successful one, the catch of adult salmon, which are the only ones canned, running from 1,500 to 4,000 per day. There is virtually no expense in taking the fish save attending to the pen.

As the fishermen who take salmon in boats in the Lower Columbia River demand and receive from 50 to 60 cents per fish from the canneries, one can readily see what a vast profit the use of the wheel makes to the cannery connected with it. A fatal objection to this device arises from the fact that it scoops up and kills little fish as well as big ones, and as yet no provision is made in connection with it, for the escape of the former. Unless the threatened wholesale killing of salmon too small for canning is prevented, the supply will be entirely cut off, and the entire canning industry destroyed, if the wheel comes into general use.—*Scientific American*.

THE PHILADELPHIA EXPERIMENT.

The attempt has recently been made in the public schools of Philadelphia to educate the hand and eye in conjunction with the brain. In December last the school board granted a fund for the purpose of teaching industrial and decorative art in the public

schools, and in April classes were opened. A large proportion of those applying for entrance to the classes wished for instruction with the view of becoming teachers, but very many were children of from twelve to fifteen years of age, who seized gladly this opportunity to learn how to make something salable. After three months' work, specimens were forwarded to the school board of what had been accomplished in painting, wood carving, needle work and metal work. Painted plaques and tiles, carved walnut panels and brackets, doilies, tidies, chair backs and hammered brass work were shown, none of which, however, represented more than the third attempt of any pupil, many being the first ones. In the coming school year, which opens this month, it is proposed that the pupils' work shall be sold, and fifty per cent of the price received given to them. In England such schools flourish in the villages. In these such trades and hand work as the following are taught: Tile Painting, leather work, wood carving, braiding, netting and mat making, sheet metal work, inlaying, etching, papier-mâché work, glass work, pottery, drawn work, calabash work, sewn leather work, fan-making, dye or tapestry, painting, modeling in clay, art needlework, Indian work, stencilling, mosaic work, bamboo and rattan work, jewelry, rustic work, horn work, turning, basket making, outline embroidery and illumination. All of these are to be taught in the Philadelphia schools.

IMPROVED FREIGHT CAR.

The engraving represents an improvement in freight cars lately patented by Mr. Francis Klier, of Cairo, Ill. The car is so constructed and arranged that it can be readily converted from a box freight car into a bottom discharging grain car. The great advantage secured by this arrangement is that the car may always be used in one way or the other, and when in use as a grain car it may be much more rapidly unloaded than the ordinary car, thus preventing the frequent blockades that arise from the slow discharge of enormous quantities of bulk grain transported by the roads.

The invention is very simple for one that accomplishes so much.

Fig. 1 in the engraving is a side elevation of the improved car, with the side of the car removed to show the internal construction. Fig. 2 is a partial plan view showing one half of the car arranged as for carrying ordinary freight, with the other half arranged as for carrying grain.

In the engraving, A represents the solid level floor of the car, depressed at its central section by removal of the floor at that point about the central opening, B. The end sections of the floor have several longitudinal parallel grooves, D, formed in them for the reception of the bars, C, which are of iron, and pivoted at one end on the borders of the middle or hopper section when the car is to be used for ordinary freight, and through these grooves and floor of the car holes are made for the reception of the supports of the bars, C, so that the said bars can, when desired, be arranged flush with the surface of the floor, A.

The false floor is constructed in two end sections, F, and two central sections, E, the former being hinged by long strap hinges to the opposite ends of the car, about twelve inches above the floor, and being of sufficient size to reach entirely across the car and half way to the central section of the fixed floor, while the central sections, E, of the false floor are hinged to the floor, A, along the edges of the hopper, and meet in the center of the car over the central opening, B, and form a portion of the ordinary freight car floor, or turn up to meet and abut against the sections, F, when they are turned down and form a portion of the sloping grain car floor.

When arranging the car for carrying the grain the bars, C, are raised from their grooves and moved laterally, and adjusted with their supports resting in socketed plates attached to the floor; the sections, F, of the false floor are then let down upon the bars, C, and the sections, E, are raised and turned back on the bars, C, forming a floor sloping from each end toward the center of the car. This floor is covered with zinc or sheet iron, so that the grain may readily slide upon it, and all the joints about the floor are made tight. The grain door is then set in place in the cast iron door sill and door jambs, and held down by iron pins or other suitable fastenings. When ready to unload the car load of grain, one man will open the outlet, B, by turning the wheels and screws below the car floor, thereby moving the slides which close the opening, apart, and the grain will then shoot through the outlet, B, into the conveyor beneath the track or into other suitable receptacle, unloading the car in less time than it would take four or five men to get into a car and begin to work at unloading in the usual manner.—*Scientific American*.

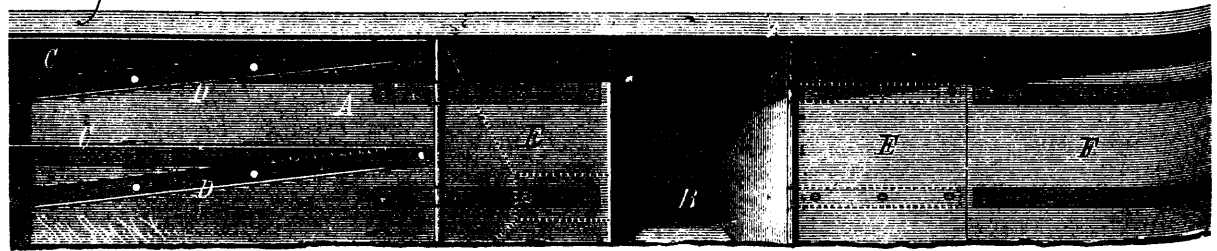
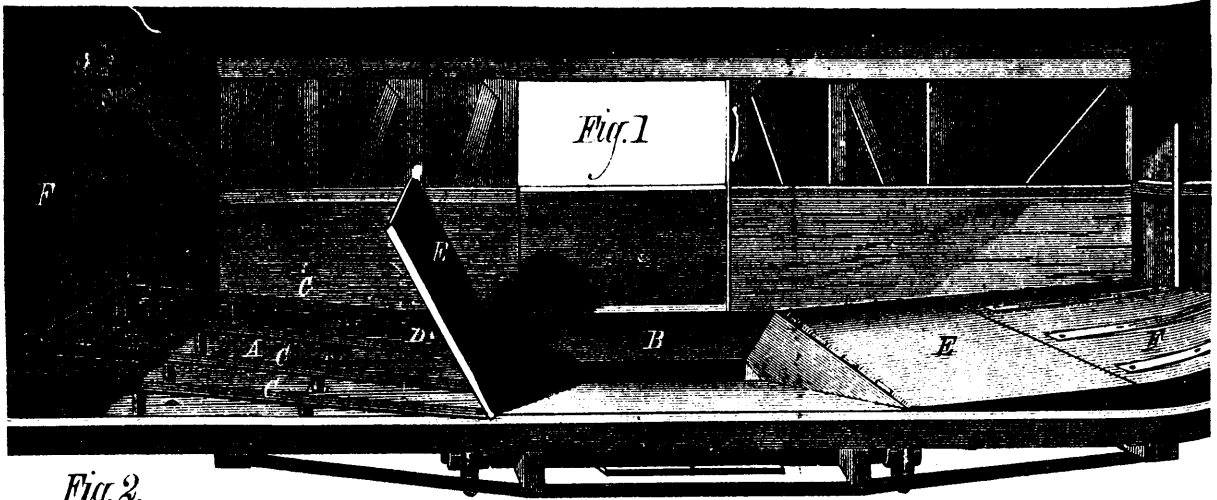

KLIER'S FREIGHT CAR.

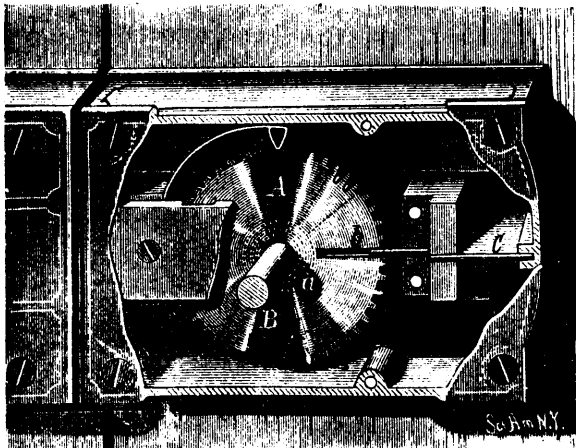

IMPROVED PERMUTATION LOCK.

The engraving shows a permutation lock of improved and simplified construction recently patented by Mr. Fred. E. Arnold, of 139 West Harrison street, Chicago, Ill. The bolt is arranged to slide in a seat in the lock casing, and the rear end of the bolt is divided longitudinally into two branches, for engagement with a tongue C, which extends from the end of the lock and which also engages with the teeth on the peripheries of the wheels A.

A shaft, B, extends through slots in the lock casing and through round holes in the bolt and in the centers of the wheels, A, and is provided with knobs or milled heads at the ends for operating it. It is also provided with a pin, *a*, for engaging with notches in the centers of the wheels, A, by which the wheels are turned. The wheels A, are each provided with a radial notch, *b*, for engagement with the tongue, C, when the bolt is moved back.

A spring pawl provided with a tapering nose engages with the teeth of the wheel, A, the fixed end of the spring being attached to the bolt. In this invention the wheels, A, move with the bolt. The bolt being locked, in order to unlock it the shaft or key, B, is adjusted so that the pin, *a*, will engage with the notches of one of the wheels, A, and is turned until the arm shown in the dotted lines abuts against the tongue, *e*. The wheel is then turned in the reverse direction until the radial notch, *b*, is exactly in line with the tongue, C. The shaft is then shifted lengthwise, and the same motions applied to the other wheel or wheels, so as to bring all the notches, *b*, in line with the tongue, C, and allow the wheels and bolt to be moved back. Where there are three of the wheels, A, employed, a ring and a wheel or plate is attached to the shaft, B, to enable the operator to adjust it to the center wheel by moving the shaft outward until the outer surface of the wheel or plate is flush with the outer edge of the ring. After adjusting the center wheel, the shaft is pulled further out, so as to bring the wheel or plate clear of the edge of the ring, and the shaft is then free to move in the slots of the casing in order to move back the wheels and bolt.

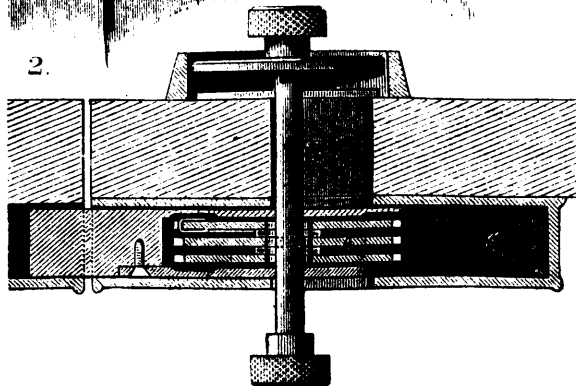

ARNOLD'S PERMUTATION LOCK.