

AUTO-POSITIVE

This Term is Descriptive of the New

PENBERTHY

SPECIAL INJECTOR

Especially Designed for High Pressures and Hot Water Supply.

ACCOMPLISHES MARVELLOUS RESULTS WITH UTMOST SIMPLICITY OF CONSTRUCTION & OPERATION.

Working Range 14 to 250 lbs. Steam. Handles Hot Water up to 145 Degrees. Send for Circulars Descriptive of this Most Wonderful Invention. Also, Remember, for Ordinary Use the World Renowned Penberthy Automatic Injector has NO EQUAL.

PENBERTHY INJECTOR COMPANY

131 SEVENTH STREET,
DETROIT, MICH.

Branch Factory:
WINDSOR, CANADA.

LARGEST INJECTOR MANUFACTURERS IN THE WORLD.

Mining, Milling & Smelting Machinery

Gold Mining Machinery with Latest Improvements.

(UNDER LICENSE FROM THE E. P. ALLIS COMPANY, MILWAUKEE.)

Stamp Mills, Crushers, Rolls, Jigs, Concentrators, Hoisting Engines,
Steam Pumps, Engines, Boilers, Shoes, Dies, Water Wheels, &c.

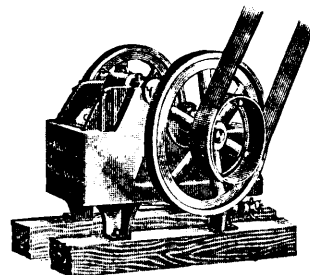
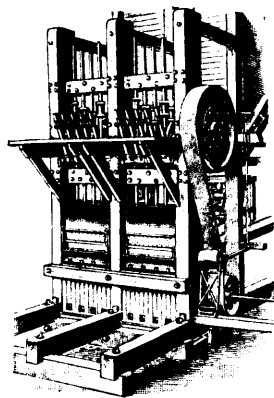
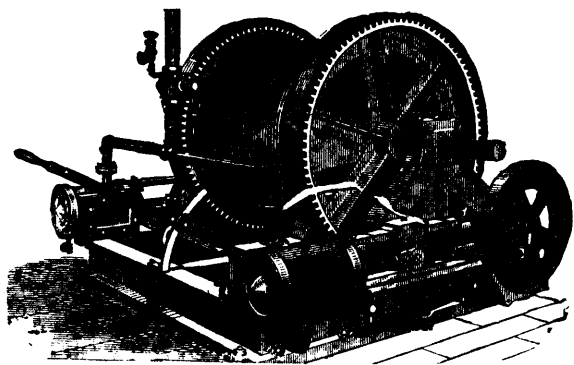

THE WM. HAMILTON MANUFACTURING CO. Limited

HEAD OFFICE AND WORKS:

Branch Office:
VANCOUVER, B.C.

PETERBOROUGH, ONT.

**AIR
COMPRESSORS**

**ROCK
DRILLS**

JAMES COOPER MANFG. CO. Limited

LATE

INGERSOLL ROCK DRILL COMPANY OF CANADA

We beg to notify our patrons and the public that the corporate name of the Company has been changed from the **INGERSOLL ROCK DRILL CO. OF CANADA** to the **JAMES COOPER MANUFACTURING CO. Limited**.

The only change is in the name, and we propose keeping up the reputation already earned for excellence in material and workmanship.

We take this opportunity of thanking our many customers for their liberal patronage in the past, and of assuring them that the high standard of "Ingersoll-Sergeant" machinery will in no way be departed from.

We invite correspondence on all subjects in connection with compressed air, or the excavation of rock, coal or ore.

JAMES COOPER MANF. CO. LIMITED

COMPLETE MINING, TUNNELLING AND QUARRYING PLANTS.

HEAD OFFICE:

MONTREAL, P.Q.

BRANCH OFFICES:

VANCOUVER, ROSSLAND AND HALIFAX

**COAL
CUTTERS**

**ORE
CRUSHERS**

**HOISTING
ENGINES**

Nova Scotia Steel Co. Ltd.

MANUFACTURERS OF

Hammered and Rolled Steel for Mining Purposes.

Pit Rails, Tee Rails, Edge Rails, Fish Plates, Bevelled Steel Screen Bars, Forged Steel Stamper Shoes and Dies, Blued Machinery Steel $\frac{3}{8}$ " to $3\frac{1}{4}$ " Diameter, Steel Tub Axles Cut to Length, Crow Bar Steel, Wedge Steel, Hammer Steel, Pick Steel, Draw Bar Steel, Forgings of all kinds, Bright Compressed Shafting $\frac{3}{8}$ " to 5" true to $\frac{1}{1000}$ part of One Inch.

A FULL STOCK OF MILD FLAT, RIVET-ROUND and ANGLE STEELS ALWAYS ON HAND. SPECIAL ATTENTION PAID TO MINERS' REQUIREMENTS. CORRESPONDENCE SOLICITED.

Works and Office: NEW GLASGOW, N. S.

THOS. FIRTH & SONS, Ltd., Sheffield,
Tool Steel and Rock Drill Steel
 ALWAYS CARRIED IN STOCK.



SHOES AND DIES.



CAMS, TAPPETS, BOSSES, ROLL SHELLS, CRUSHER PLATES.



JAMES HUTTON & CO.

Agents for Canada.

MONTREAL.



Adamantine Shoes and Dies and Chrome Cast Steel,

CAMS, TAPPETS, BOSSES, ROLL SHELL and CRUSHER PLATES.

Also Rolled Parts for Huntington and Other Mills.

These castings are extensively used in all the Mining States and Territories of North and South America. Guaranteed to prove better and cheaper than any others. Orders solicited subject to above conditions. When ordering send sketch with exact dimensions. Send for Illustrated Catalogue to

CHROME STEEL WORKS,

BROOKLYN, N. Y., U. S. A.

KENT AVENUE, KEAP AND HOOPER STREETS.

C. P. HAUGHIAN, President.

F. E. CANDA, Vice-President.

C. J. CANDA, Secretary.

J. G. DUNSCOMB, Treasurer.



H. H. FULLER & CO.

41-45 UPPER WATER ST.,

HALIFAX, N. S.

.... WHOLESALE AND RETAIL DEALERS IN

Builders', Blacksmiths' and General Hardware.

Mining and Mine Supplies a Specialty.

SOLE AGENTS IN NOVA SCOTIA for Boston Belting Co's Rubber Goods, and Reeves' Wood Split Pulleys.

Correspondence Solicited.

P. O. BOX 178.

Shipments Promptly and Carefully Attended to.



650 IMPERIAL CYLINDER OIL

Is recognized as being the best Cylinder Oil made for High-pressure Engines.

MANUFACTURERS

..IMPERIAL OIL CO. Ltd.

Petrolea, London, Toronto, Hamilton, Brantford, Peterborough, Windsor, Quebec, Kingston, Montreal, Moncton, N.B., Halifax, N.S., St. John, N.B., Winnipeg, Vancouver.

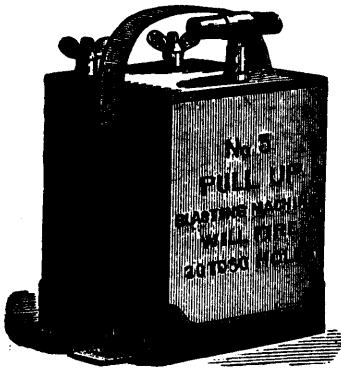

Electric Blasting

VICTOR ELECTRIC PLATINUM FUSES.

Superior to all others for exploding any make of dynamite or blasting powder. Each fuse folded separately and packed in neat paper boxes of 50 each. All tested and warranted. Single and double strength, with any length of wires.

"PULL-UP" BLASTING MACHINE.

The strongest and most powerful machine ever made for Electric Blasting. No. 3 fires 30 holes. No. 4 fires 50 holes. No. 5 fires 100 holes. They are especially adapted for submarine blasting, large railroad quarrying and mining works.

VICTOR BLASTING MACHINE.

No. 1 fires 5 to 8 holes; weighs only 15 lbs. Adapted for prospecting, stump blasting, well sinking, etc. Standard Electric Fuse and Blast Tester, Wire Reels, new design. Leading and Connecting Wires.

Manufactured only by **JAMES MACBETH & CO.,**

SEND FOR CATALOGUE.

128 MAIDEN LANE, NEW YORK CITY.

FRIED. KRUPP, GRUSONWERK, MAGDEBURG-BUCKAU, (GERMANY.) ENGINEERING WORKS, IRON AND STEEL FOUNDRY.

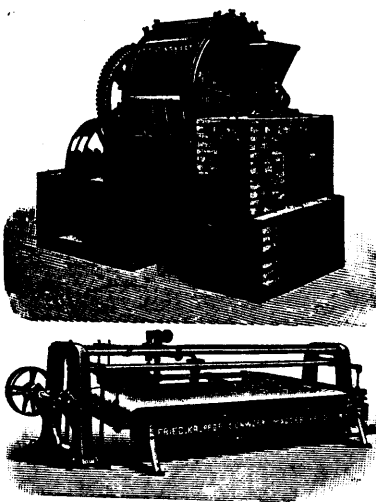

MINING and MILLING MACHINERY.

Gruson Rock and Ore Crushers of specially strong construction.

ROLLER MILLS, STAMP BATTERIES, CHROME STEEL SHOES AND DIES.

Ball Mills, with a continuous feed and discharge, improved system for reducing ores to any degree of fineness

MORE THAN 1,100 AT WORK.

Amalgamating Apparatus, Hydraulic Classifiers, Jig Machines, Round Buddles, Improved Rotary Tables, Improved Percussion Tables, Sweeping Tables; Amalgam Cleaners. Amalgam-Distilling and Gold Smelting Furnaces, etc.

COMPLETE CONCENTRATION PLANTS, . . .

CYANIDE PLANT.

Sixteen Awards at the Columbian Exposition.

AGENTS:

CANADA: { **JAS. W. PYKE & COMPANY,**
35 St. Francois Xavier St.,
MONTREAL

For the United States: **THOS. PROSSER & SON,** 15 Gold Street, New York.
For Mexico: Oficina Tecnica de las Fabricas de Fried. Krupp, Essen y Fried. Krupp Grusonwerk, Magdeburg-Buckau, Apartado 349, Mexico. For South Africa: **United Engineering Company, Ltd.,** P. O. Box 399, Johannesburg, S. A. R.

TRURO FOUNDRY & MACHINE CO

Engineers BoilerMakers' and Founders

TRURO N.S.

MACHINERY

WITH LATEST IMPROVEMENTS

WINDING ENGINES

Special Mixture, Shoes & Dies
With the **BEST RECORD** IN THE WORLD

Wearing quality unsurpassed ROTARY SAW MILLS.

MICA BOILER COVERINGS.

Tested by Mechanical Experts of the Canadian Pacific Ry. Co., Grand Trunk Ry. Co., Michigan Central Ry. Co. Boiler Inspection and Insurance Co., and proved to be the BEST OF ALL NON-CONDUCTORS.

All Steam Users should see the New Mica Boiler and Pipe Covering. It is Flexible, Durable and a Non-Conductor of Heat.

Full Particulars, Reports of Trials, Prices, Testimonials, &c., from

THE MICA BOILER COVERING COMPANY, Limited, 9 JORDAN STREET, TORONTO, ONT.

THE ROYAL... ELECTRIC CO.

Western Office:
TORONTO

MANUFACTURERS OF...

MONTREAL

ELECTRICAL MACHINERY AND APPARATUS

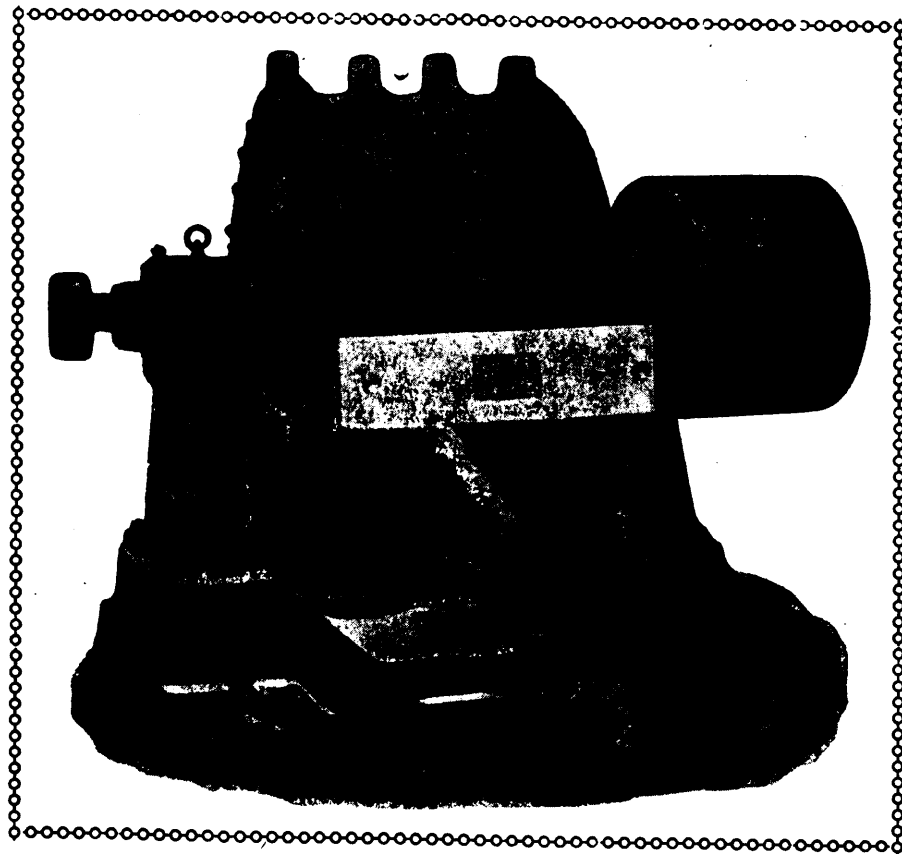

Tramways
Hoists
Locomotives
Pumps

Compressors
Fans
Stamps
Drills

... FOR ...

MINING AND TRANSMISSION OF POWER.

OUR S. K. C. TWO PHASE SYSTEM

Renders distant Water Powers available for all kinds of Mining Work

WRITE US YOUR REQUIREMENTS AND WE WILL FURNISH YOU WITH ESTIMATES AND PLANS

DIAMOND DRILLS FOR PROSPECTING MINERAL LANDS

Most Accurate and Most Economical Prospecting Drill Made.

The Government of the Province of Ontario purchased in August, 1894, a Sullivan Diamond Drill, Capacity 1500 ft.
The Government of the Province of New Brunswick has just ordered a duplicate of the Ontario Drill.

Drills of all capacities, operated by hand or horse power, steam, compressed air or electricity, for sale by

KNIGHT & STONE, N. W. Agents.
ROSSLAND, B. C.
SPOKANE, WASH.

SULLIVAN MACHINERY COMPANY,

54 North Clinton Street,
CHICAGO, ILL.

CONTRACTORS FOR PROSPECTING MINERAL LANDS WITH THE DIAMOND DRILL.



THE DESSAU COMPANY
Lorsch Building, 37 & 39 MAIDEN LANE, N. Y.
IMPORTERS OF
CARON (Black Diamonds) FOR DIAMOND DRILLS
And All Mechanical Purposes.



BRAZILIAN AND AFRICAN BORTZ.
BEST QUALITY AT LOWEST PRICES.

"ASBESTIC"

THE KING OF WALL PLASTERS.
FIREPROOF being purely Asbestos which is incombustible.
NON-CONDUCTOR OF HEAT.
NO CRUMBLING OR CRACKING.
INTRINSICALLY CHEAPER than any other Plaster.



A Few of the Principal Buildings Plastered with Asbestic:
THE McDONALD BUILDING, Victoria Square, Montreal.
THE Y. W. C. A. BUILDING, Montreal.
THE ROYAL VICTORIA COLLEGE, Montreal.
THE PROTESTANT INSANE ASYLUM, Verdun, near Montreal.
THE GRAND HOTEL, St. Hyacinthe, Que.
THE NEW CUSTOMS-APPRAISERS' STORES, New York, New building, which will consume 5,000 tons.
THE PARLIAMENT BUILDINGS, Ottawa, portion of which was lately destroyed by fire and rebuilt.

THE AMERICAN ASBESTIC CO.,
100 WILLIAM STREET, NEW YORK.
Sole Proprietors of "ASBESTIC" for United States and Canada.

BULLOCK DIAMOND DRILLS.

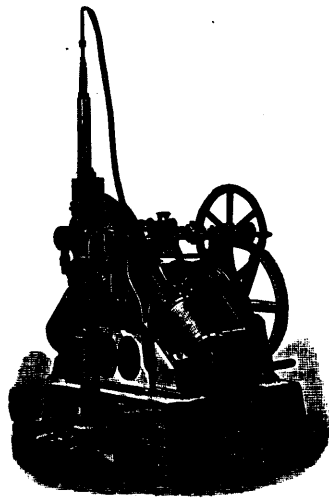

"DELVER" Diamond Drill.
HOLE, 2,500 FT. DEEP.
CORE, 2 IN. DIAMETER.

Extract Cores showing the nature of all formations penetrated, and furnishing a sample for assaying. They are the only Drills which indicate the exact thickness and character of every stratum.

.... FIFTEEN STYLES AND SIZES....
Adapted to All Requirements.

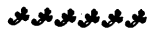

Manufactured Exclusively by

M. C. BULLOCK MFG. CO.

1177 W. LAKE STREET, CHICAGO, U. S. A.

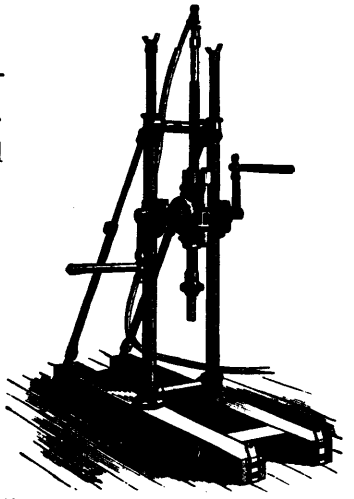

"BRAVO" Hand Power Drill.
HOLE, 350 FT. DEEP.
CORE, 1 3/16 IN. DIAMETER.

Ottawa Powder Company, Ltd.

ESTABLISHED 1891.

MANUFACTURERS OF **DYNAMITE AND TRIOLINE.**

Dealers in Safety Fuse, Platinum Fuses, Detonators, and all Blasting Supplies. All Orders Promptly Attended to Under Guarantee of Excellence.



CENTRAL OFFICE:
CENTRAL CHAMBERS, OTTAWA, ONT.

MILL AND MINING MACHINERY.

Shafting, Pulleys, Gearing, Hangers, Boilers, Engines, Steam Pumps, Chilled Car Wheels and Car Castings. Brass and Iron Castings of Every Description. Light and Heavy Forgings.

ALEX. FLECK, - Vulcan Iron Works, - OTTAWA.

HAMILTON POWDER COMPANY.

Manufacturers of Sporting, Military and Blasting

GUNPOWDER, DUALIN, DYNAMITE and ECLIPSE.

Dominion Agents for Safety Fuse, Electric Blasting Apparatus, Etc.

Office: 103 St. Francois Xavier St., Montreal.

Branch Offices and Magazines at all Chief Distributing Points in Canada.

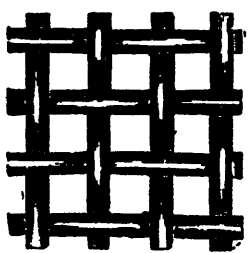

WIRE CLOTH •• ALL ••
GRADES

... FOR ...

RIDDLES, *etc. etc. etc.*

SCREENS, ETC.

MINING PURPOSES.

MANUFACTURED BY **George B. Meadows,** 128 KING STREET, WEST, TORONTO, ONTARIO.

Iron and Steel Structures for Collieries,
Metal Mines and Smelting Works. . . .

Steel Bridges for Railways and Highways. Steel Piers and Trestles. Steel Water Towers and Tanks. Steel Roofs, Girders, Beams, Columns, for Buildings.

ROLLED STEEL BEAMS, JOISTS, GIRDERS, CHANNELS, ANGLES, TEES, Z BARS AND PLATES

ALWAYS ON HAND, IN LENGTHS TO THIRTY-FIVE FEET

Tables, giving Sizes and Strength of Rolled Beams, on application.

Post Office Address,

MONTREAL.

Dominion Bridge Co., Ltd., Montreal and Lachine Locks, P. O.

Office, 8 PINE ST.—SAN FRANCISCO, CAL.—WORKS, 332 BAY ST.

CALIFORNIA WIRE WORKS.

SIMPLICITY, FOR the economical transportation of material over rugged Countries. Ore, **DURABILITY** Coal, Sand, Fuel, Sugar Cane, Etc., Etc. Satisfaction and Economy Guaranteed. 200 Lines in Operation. Spans 200 to 2000 feet. Send for Illustrated Pamphlet.

Address

CALIFORNIA WIRE WORKS,

332 BAY STREET, SAN FRANCISCO, CAL., U. S. A.



HALLIDIE ROPEWAY.

THE COLORADO IRON WORKS CO.

DENVER, COLORADO, U.S.A.

ENGINEERS AND MANUFACTURERS

SILVER-LEAD, COPPER
AND PYRITIC
SMELTING FURNACES
and...
FURNACE EQUIPMENTS
ROASTING FURNACES
and...
ORE DRYERS
STAMP MILLS
DRY CRUSHING MILLS

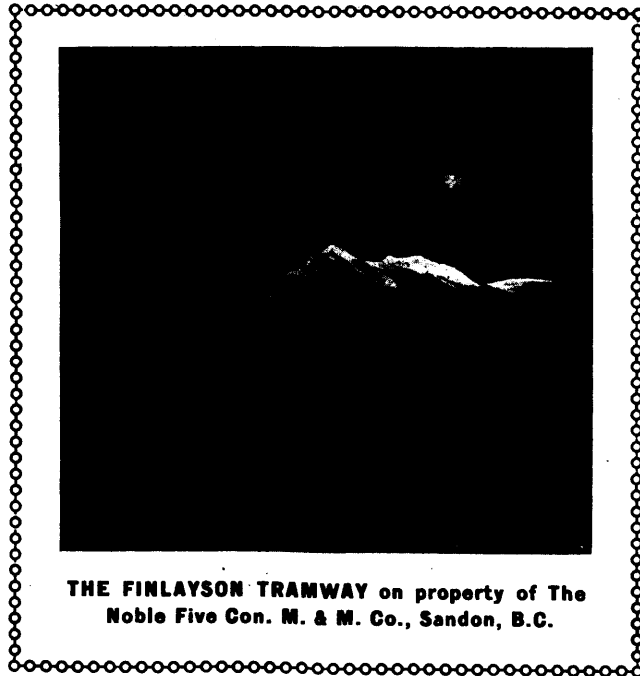

THE FINLAYSON TRAMWAY on property of The
Noble Five Con. M. & M. Co., Sandon, B.C.

CYANIDE and
CHLORINATION
PROCESS PLANTS
CRUSHING ROLLS
VANNERS
PERFECTION
CONCENTRATORS
ORE FEEDERS
FORGED STEEL
SHOES AND DIES
Etc. Etc. Etc.

SOLE AGENTS AND
MANUFACTURERS OF

The Finlayson Patent Wire Rope Tramway

The latest and best aerial Tramway ever introduced. Its automatic features, economy of operation, large capacity, etc., etc., place it far ahead of all other makes. Send for special descriptive pamphlet.

RIBLET & PORTER, REPRESENTATIVES FOR BRITISH COLUMBIA, SPOKANE, WASH.

JOHN A. ROEBLING'S SONS CO.

MANUFACTURERS OF

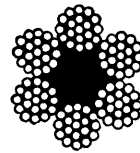

OF ALL KINDS.

Mining Ropes a Specialty.

ALSO, IRON, STEEL AND COPPER WIRE OF EVERY DESCRIPTION.

117 and 119 LIBERTY STREET, NEW YORK. H. L. SHIPPY,
MANAGER.

Office and Works: TRENTON, N. J.

Office and Warerooms: 173 LAKE ST., CHICAGO.

25 FREMONT ST., SAN FRANCISCO.

MACHINERY DEPOT.

A. R. WILLIAMS & CO.

Write for Quotations on Mining and Quarrying Machinery, Engines, Boilers,
Pumps, Ore Breakers and Machinery Supplies of all Kinds—Immense Stock.

345-347 St. JAMES STREET, MONTREAL, QUE.

F. B. POLSON

J. B. MILLER

POLSON IRON WORKS

TORONTO, ONT.

THE BEST EQUIPPED BOILER AND ENGINE WORKS IN CANADA

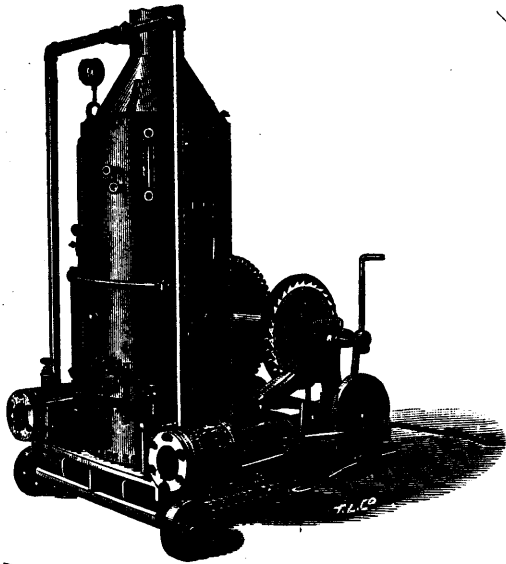

Hoisting Engines
Steel Boilers . . .
Mine Pumps . . .
Rock and
Ore Breakers . . .



STEAM YACHTS AND LAUNCHES
The Brown Automatic Engine

GET OUR PRICES BEFORE ORDERING

ESPLANADE FOOT OF SHERBOURNE ST. **TORONTO.**

Joshua Hendy Machine Works

OFFICE & SALESROOM: 38 TO 44 FREMONT ST. **SAN FRANCISCO, CAL., U. S. A.**
WORKS: CORN. KEARNY, FRANCISCO & BAY STS.

MANUFACTURERS OF AND DEALERS IN

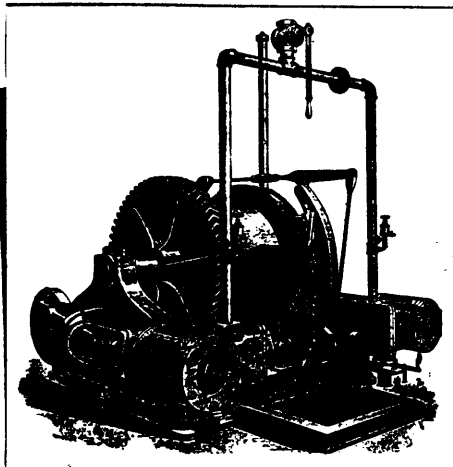

Hydraulic Mining Quartz and Saw Mill Machinery

COMPRISING

Air Compressors and Drills,
"Cornish" Pumps,
Gold Mills and Appliances,
Hoisting Engines,
Horse-Power Whims,

Hydraulic Derricks,
Hydraulic Giants,
Hydraulic Gravel Elevators,
Hydraulic Hoists,
Hydraulic Mining Plants,

Ore Buckets,
Ore Cars,
Ore Concentrators,
Ore Crushers,
Ore Feeders.

"Hendy" Improved "Triple Discharge" Two-Stamp Quartz Mills.

SHEET-IRON AND STEEL PIPE FOR HYDRAULIC MINING.

Plans and Specifications and Estimates of Cost Furnished and Contracts made for supplying and erecting Mining and Milling Plants for all conditions of use.

FRASER & CHALMERS

CHICAGO, ILL., U.S.A.

MANUFACTURERS OF

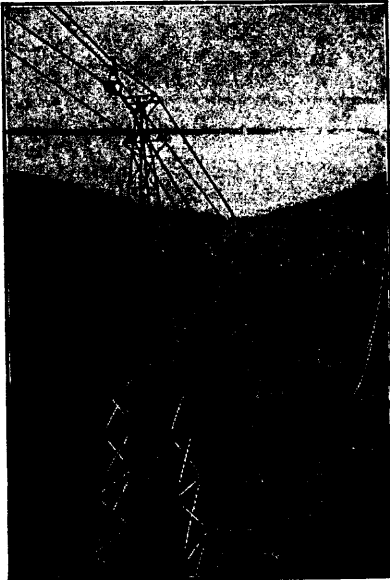

MINING MACHINERY
 STAMP MILLS
 SMELTERS, ENGINES
 BOILERS
 RIEDLER
 AIR COMPRESSORS
 and PUMPS
 OTTO TRAMWAYS
 a Specialty
 PERFORATED METALS
 RIVETED STEEL PIPE
 Etc. Etc.

Write for Prices and Particulars on Any Class of Mining Plant.

UNION GAS OR OIL ENGINE AND HOIST COMBINED ON STRONG IRON BASE.

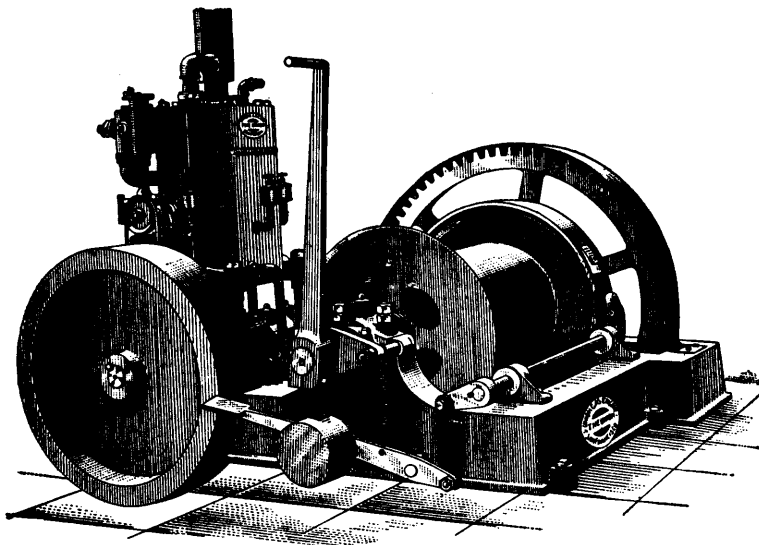

NO FIRE. NO STEAM. NO BOILER. NO DANGER.

Ten years' experience. About two thousand Engines in use.
 Started instantly. Compact, Strong, Simple, Efficient, Economical.
 Perfectly governed, so that oil is used only in proportion to the work done.
 No expense when idle.
 Particularly adapted to Mining and Ship and Wharf use.
 Built in sizes, 6 to 50 horse power.
 Also builders of Marine and Stationery Gas and Naptha Engines.
 Send for Catalogue and state horse power required.

UNION GAS ENGINE CO.

318 Howard St. SAN FRANCISCO, CAL.

**IT PAYS TO
ADVERTISE**

IN THE **CANADIAN ...
MINING REVIEW**

The Oldest and Only Official Mining Paper in Canada

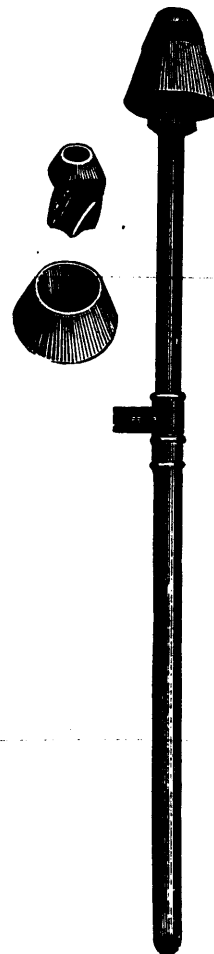
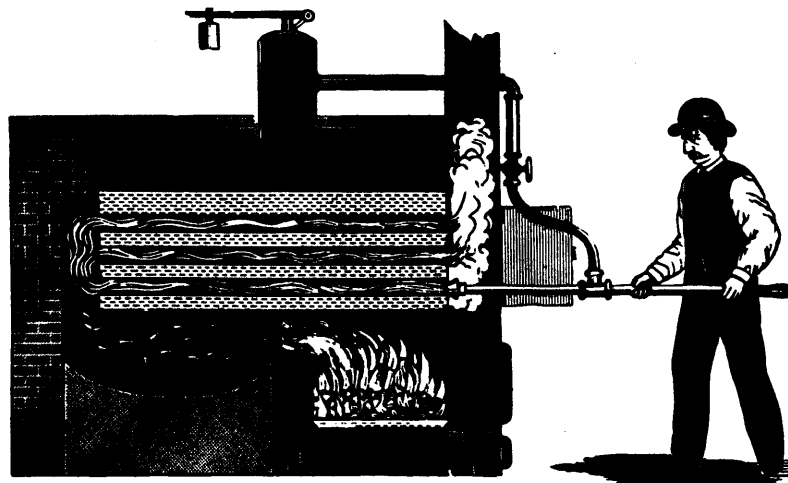

STEAM TUBE CLEANER

FIVE MINUTES TO THOROUGHLY CLEAN YOUR BOILER TUBES WITH THE
HAMILTON BRASS MFG. CO'S STEAM TUBE CLEANER

Hamilton Brass Manufacturing Co.

HAMILTON, ONT.

SCHOOL OF MINING,

KINGSTON, ONTARIO.



The Following Courses are offered 

1—Three Years' Course for a Diploma in

- (A) Mining Engineering.
- (B) Analytical Chemistry and Assaying.

2—Four Years' Course for a Degree in

- (A) Mining Engineering.
- (B) Chemistry and Mineralogy.
- (C) Mineralogy and Geology.

3—Post-Graduate Course for the Degree of

Doctor of Science (D.Sc.)
For further information see the calendar of Queen's University.

4—Prospector's Course.

The School offers to Mine Foremen, Assayers, Prospectors and Mining Men generally, Special Courses of Instruction beginning January 4th, 1898, and continuing eight weeks.

5—Extramural Classes for Prospectors and Mining Men.

Lecturers are sent to Mining Centres to conduct Classes in Elementary Chemistry, Mineralogy and Geology as applied to the discovery and winning of valuable minerals.

The School is provided with well equipped Laboratories for the study of Chemical Analysis, Assaying, Blowpiping, Mineralogy, Petrography and Drawing. In the Mining Laboratory the operations of Crushing, Amalgamating, Concentrating, Chlorinating, Cyaniding, etc., can be studied on a large scale.

FOR CALENDAR OF THE SCHOOL AND FURTHER INFORMATION APPLY TO 

WM. MASON, Bursar,
SCHOOL OF MINING, KINGSTON, ONTARIO.



PROVINCE OF NOVA SCOTIA.

Leases for Mines of Gold, Silver, Coal, Iron, Copper, Lead, Tin

—AND—

PRECIOUS STONES.

TITLES GIVEN DIRECT FROM THE CROWN, ROYALTIES AND RENTALS MODERATE.

GOLD AND SILVER.

Under the provisions of chap. 1, Acts of 1892, of Mines and Minerals, Licenses are issued for prospecting Gold and Silver for a term of twelve months. Mines of Gold and Silver are laid off in areas of 150 by 250 feet, any number of which up to one hundred can be included in one License, provided that the length of the block does not exceed twice its width. The cost is 50 cents per area. Leases of any number of areas are granted for a term of 40 years at \$2.00 per area. These leases are forfeitable if not worked, but advantage can be taken of a recent Act by which on payment of 50 cents annually for each area contained in the lease it becomes non-forfeitable if the labor be not performed.

Licenses are issued to owners of quartz crushing mills who are required to pay

Royalty on all the Gold they extract at the rate of two per cent. on smelted Gold valued at \$19 an ounce, and on smelted gold valued at \$18 an ounce.

Applications for Licenses or Leases are receivable at the office of the Commissioner of Public Works and Mines each week day from 10 a.m. to 4 p.m., except Saturday, when the hours are from 10 to 1. Licenses are issued in the order of application according to priority. If a person discovers Gold in any part of the Province, he may stake out the boundaries of the areas he desires to obtain, and this gives him one week and twenty-four hours for every 15 miles from Halifax in which to make application at the Department for his ground.

MINES OTHER THAN GOLD AND SILVER.

Licenses to search for eighteen months are issued, at a cost of thirty dollars, for minerals other than Gold and Silver, out of which areas can be selected for mining under lease. These leases are for four renewable terms of twenty years each. The cost for the first year is fifty dollars, and an annual rental of thirty dollars secures each lease from liability to forfeiture for non-working.

All rentals are refunded if afterwards the areas are worked and pay royalties. All titles, transfers, etc., of minerals are registered by the Mines Department for a nominal fee, and provision is made for lessees and licensees whereby they can acquire promptly either by arrangement with the owner or by arbitration all land required for their mining works.

The Government as a security for the payment of royalties, makes the royalties first lien on the plant and fixtures of the mine.

The unusually generous conditions under which the Government of Nova Scotia grants its minerals have introduced many outside capitalists, who have always stated that the Mining laws of the Province were the best they had had experience of.

The royalties on the remaining minerals are: Copper, four cents on every unit; Lead, two cents upon every unit; Iron, five cents on every ton; Tin and Precious Stones; 6ve per cent.; Coal, 10 cents on every ton sold.

The Gold district of the Province extends along its entire Atlantic coast, and varies in width from 10 to 40 miles, and embraces an area of over three thousand miles, and is traversed by good roads and accessible at all points by water. Coal is known in the Counties of Cumberland, Colchester, Pictou and Antigonish, and at numerous points in the Island of Cape Breton. The ores of Iron, Copper, etc., are met at numerous points, and are being rapidly secured by miners and investors.

Copies of the Mining Law and any information can be had on application to

THE HON. C. E. CHURCH,

Commissioner Public Works and Mines,

HALIFAX, NOVA SCOTIA.

OLD SYDNEY COAL.

.....

S. CUNARD & CO., Halifax, N. S.

Shipping, Commission and Coal Merchants, Agents for
Allan, Cunard, White Star, American, Red Star, Hill,
Atlantic Transport, Compagnie Generale Trans-
Atlantique Lines of Steamers; also

General Mining Association, Ltd.

COLLIERY, SYDNEY MINES, C. B.

Liverpool, Glasgow, French and Austrian Underwriters.

CONSULAR AGENCY OF FRANCE.

BUNKERING STEAMERS ATTENDED TO WITH DESPATCH.

SPRINGHILL COAL.

THE CUMBERLAND RAILWAY & COAL COMPANY

Are prepared to deliver this well known Steam
Coal at all points on the lines of G.T.R.,
C. P. R. and I. C. Railways.

HEAD OFFICE: 107 ST. JAMES STREET, MONTREAL.

Address: P. O. BOX 396.

DRUMMOND COAL.

THE INTERCOLONIAL COAL MINING CO. LIMITED.

HENRY A. BUDDEN, Vice-Pres. and Man. Dir.
WM. J. NELSON, Secretary-Treasurer.

Drummond Colliery, Westville, Nova Scotia.

CHAS. FERGIE, M.E., Manager.

MINERS AND SHIPPERS OF

BITUMINOUS COAL AND COKE

At Pictou Harbour and Intercolonial Ry.

HEAD OFFICE: MONTREAL.

DOMINION COAL COMPANY

OWNERS OF THE

Victoria, International,
Dominion, Bridgeport,
Gowrie, Caledonia,
and Reserve Collieries,

OFFERS FOR SALE

STEAM, GAS and DOMESTIC

OF HIGHEST COALS QUALITIES

Carefully prepared for Market by Improved Appliances, either
F.O.B. or Delivered.

*It is also prepared to enter into Contracts with
Consumers covering a term of years.*

*Its facilities for supplying Bunker Coal with
promptness is unequalled.*

APPLICATION FOR PRICES, ETC., TO BE MADE TO

J. S. McLENNAN, Treasurer,
95 MILK ST., BOSTON, MASS.

HIRAM DONKIN, Resident Manager, Glace Bay, Cape Breton.
M. R. MORROW, 50 Bedford Row, Halifax.
KINGMAN, BROWN & CO., Custom House Square, Montreal.

HARVEY & OUTERBRIDGE, Produce Exchange Building, New
York, Sole Agents for New York and for Export.

ESTABLISHED 1864.

THE BEST EQUIPPED SHOP IN CANADA.

HOISTING and HAULAGE ENGINES

Of Improved Design and Construction. Strong and Efficient. Best in the Market.

MINING MACHINERY

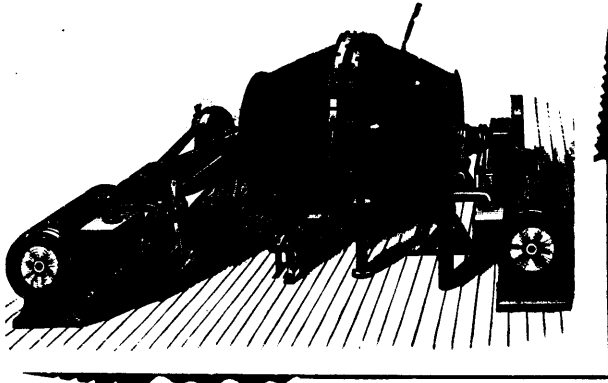

ROCK AND ORE BREAKERS, CRUSHING ROLLS, ORE WASHERS, MINE CARS, SCREWS AND ELEVATORS.

Every Kind and Size of Engines and Boilers. Pumping Engines of all Types. Rotary Saw Mill Machinery. Best Builders in Canada of Dredges, Derricks, Steam Shovels and other Contractor and Quarrymen's Machinery.

STOVES OF ALL KINDS.

Ship Builders, Marine Engines and Boilers.



If you want any New Machinery or something Special send us your specification—then rely to get what you want. We employ 400 Hands. Write us for Prices.

Carrier, Laine & Co.

LEVIS, QUEBEC.

263 St. Joseph Street, Quebec.—BRANCH OFFICES—145 St. James Street, Montreal.

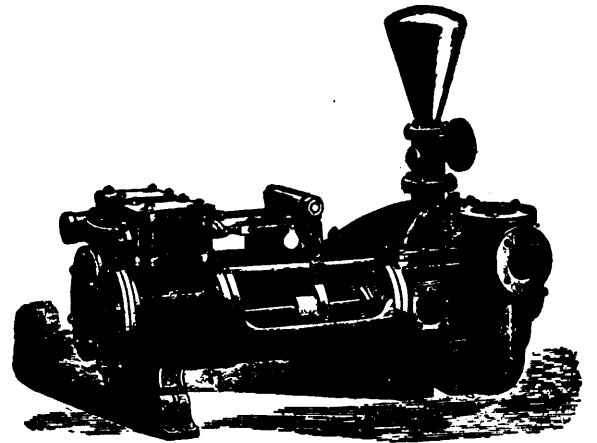

FIRE AND BURGLAR-PROOF
SAFES!
OF ALL KINDS AND SIZES.

We make Safes with CHROME STEEL LINING, a style most useful for Gold or Silver Mining Companies. We have these both New and Second Hand in Stock.

J. & J. TAYLOR,
TORONTO SAFE WORKS,
TORONTO, ONTARIO.

J. Bertram & Sons, Canada Tool Works,

DUNDAS, ONT.

Builders of Iron

•••• WORKING MACHINERY

.... FOR....

REPAIR SHOP, MACHINE SHOP, SHIP YARDS,
BOILER SHOPS, ENGINE WORKS,
CAR SHOPS, FORGE WORKS.

OUR EQUIPMENT AND WORKS ARE THE LARGEST IN CANADA.

OUR LINE OF

MACHINE TOOLS

WILL SUPPLY A SHOP COMPLETE.

MONTREAL
... STORE: 321 St. JAMES STREET.

B.C. Agency: The Wm. Hamilton Mfg. Co., Vancouver, B.C.

Full Information obtained at the Above Addresses. Write for Prices.

CANADIAN GENERAL ELECTRIC COMPANY, Ltd.

Head Office: 65 FRONT ST. WEST, TORONTO, ONT.

BRANCH OFFICES AND WAREHOUSES:

| | | | | | | |
|---------------------|-------|----------|---|------------------|-----------|-----------|
| 1802 Notre Dame St. | - - - | MONTREAL | } | Main Street | - - - - - | WINNIPEG |
| 138 Hollis Street | - - - | HALIFAX | | Granville Street | - - - - - | VANCOUVER |

NELSON, B.C.

FACTORIES: PETERBOROUGH, ONT.

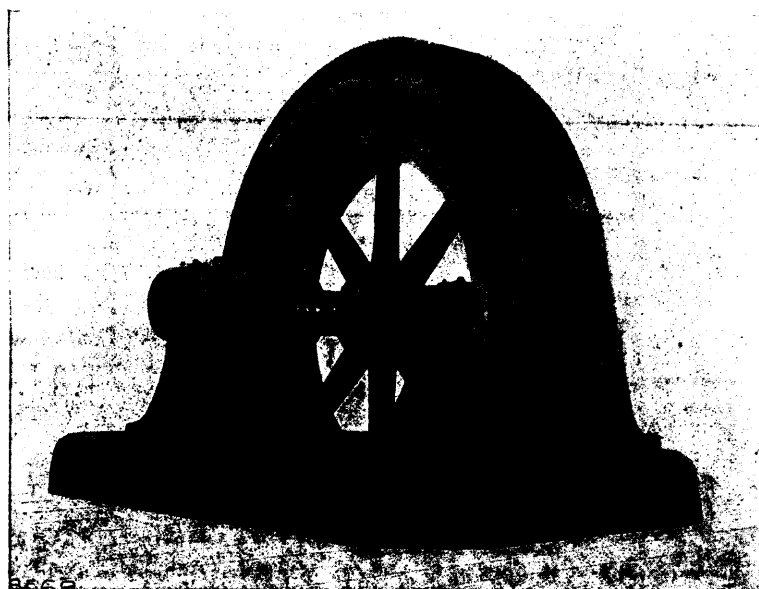

C. G. E. ALTERNATING GENERATOR, REVOLVING FIELD TYPE.

THE WEST KOOTENAY POWER AND LIGHT CO. Limited

have just commenced work on the most important power transmission plant so far undertaken in Canada outside of the immediate neighborhood of the city of Montreal. The distance of transmission is thirty miles, the line potential 20,000 volts, and the amount of power to be developed 8,000 horse power. For this important work the three-phase system of the Canadian General Electric Company has been selected and a contract awarded for the initial installation of 2,000 horse power. The generators will be of the revolving field type, and of 1,000 horse power capacity each. In type they will be generally similar to the twelve 1,000 horse power units now being installed for the Lachine Rapids Hydraulic and Land Co.

Mining Properties Examined and Reported on.
25 Years' Experience.

A. T. Anderson & Co.

PATENT AND MINING BROKERS,
And Mining Machinery Agents.

62 ADELAIDE ST., EAST, TORONTO.

E. S. TOPPING, TRAIL, B. C.

Has for Sale

Mines and Prospects on Lookout Mountain, Rossland, Salmon River and all other parts of the Columbian Basin. Lots in Trail. Lots and 20 acre garden plots in Deer Park. Will buy Stock for outside investors and try to protect them from wild-cats. Will examine mines.

DIVIDEND PAYING

*Mining Stocks and
Other Investments.*

ALL REPRESENTATIONS GUARANTEED.

J. M. HARRIS, SANDON.

SADLER & HAWORTH

MANUFACTURERS OF

OAK TANNED LEATHER BELTING...

MONTREAL and
TORONTO.

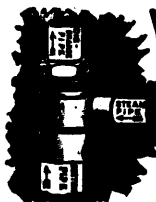

VANDUZEN STEAM PUMP
JET
THE BEST IN THE WORLD.
Pumps Any Kind of Liquid.
Always in Order, never Clogs nor
freezes. Every Pump Guaranteed.
10 SIZES.
200 to 12000 Gallons per Hour.
Cost \$7 to \$75 each. Address
GARTH & CO.,
636 to 642 Gray St. MONTREAL

KING BROS.

Miners of Crude Asbestos

ALL GRADES.

Head Office: BELL'S LANE, Quebec.

MINES AT THETFORD STATION,
QUEBEC CENTRAL RY, QUEBEC.

MICHIGAN COLLEGE OF MINES.

A State technical school. Practical work. Special facilities for men of age and experience. Elective system. Forty-five weeks a year. Non-resident tuition \$150 a year. For Catalogues address

Dr. M. E. WADSWORTH, Pres., Houghton, Mich.

W. J. WATERMAN, Mining Engineer, 610 GRANVILLE ST., Box 123. VANCOUVER, B. C.

Telegraph Address, WATERMAN, Vancouver.

MONTREAL TESTING LABORATORY.

MILTON L. HERSEY, B.A. Sc.,

CONSULTING CHEMIST OF THE
CANADIAN PACIFIC RAILWAY COMPANY.
Formerly Demonstrator in Chemistry, Faculty of Applied
Science, McGill University.

ASSAYER AND MINERALOGIST

ASSAYS OF ORES

Minerals, Bullion, etc., Analyses of Lubricants, Paints,
Cements, Fuels, Iron, Steel, etc. Largest and
best equipped Private Testing Labora-
tories in Canada.

MINERAL PROPERTIES EXAMINED.

ANALYSES of all materials made with greatest accuracy. In-
struction in Assaying, etc., to Prospectors and others. Aluminium
Assay Balance, sensibility 1-24,000 grain.

Special Rates to Mining Companies.

SAMPLES BY MAIL—1 cent per 4 ozs.; limit 24 ozs.

OFFICE AND LABORATORY:

16 ST. SACRAMENT ST.,
MONTREAL.

[Few Doors East of Board of Trade Building]

ORFORD COPPER CO.

Copper Smelters

WORKS AT CONSTABLE'S HOOK, N. J.
Opp. New Brighton, Staten Island.

Copper Ore, Mattes, or Bullion Purchased. Advances
made on Consignments for Refining and Sale.
Specialty made of Silver-bearing Ores and Mattes.

SELL

INGOT AND CAKE COPPER.

Robert M. Thompson, G. A. Land,
President. Treasurer.

Office, 37 to 39 Wall Street, New York.

PATENTS PROCURED ON MINING INVENTIONS

BY RIDOUT & MAYBEE, 103 BAY STREET, TORONTO.
Telephone 2582.

Foreign Members of Chartered Institute of Patent Agents,
England.

Send for Free Pamphlet on Patents, Etc.

ARTHUR W. B. WHITELEY, E.M.

Consulting Mining Engineer and Metallurgist

MANAGEMENT AND REPORTS.

MINE CENTRE, ONT., CAN.

P.O. Address: Harding Crane Lake Mine.

Moreing and Wells' Code.

ALEXANDER DICK

Civil and Mining Engineer

QUEEN BUILDING, HOLLIS ST.

HALIFAX, N.S.

May be consulted on the opening and development of
mining properties. Reports and estimates made on instal-
lation of plants and costs of mining, &c. Thoroughly
equipped for all kinds of surface and underground surveys.
The location of old boundary lines a specialty.

P. O. BOX 112.

LEDOUX & COMPANY

9 CLIFF STREET, NEW YORK.

ENGINEERS, METALLURGISTS and ASSAYERS.

Public Ore Sampling and Storage Works.

All the principal buyers of furnace materials in the
world purchase and pay cash against our certificates of
assay, through New York banks.

By special permission of the Secretary of the Treas-
ury of the United States, cars of Ore or Copper Matte
passing through in bond can be opened and sampled at
our works.

Consignments received and sold to highest bidder.
Send for circular giving full particulars.

Mines Examined and Sampled. Assays and
Analyses of all kinds.

F. H. MASON,

Late Chemist and Assayer to the Newbery Vautin (Patents) Gold
Extraction Co., Ltd. (Chlorination Process.)

Consulting Metallurgist, Analytical Chemist and Assayer

Refractory Gold Ores, Concentrates and Tailings a
Specialty.

Ores in 100 lb. lots tested by Chlorination and other
Wet Processes.

Chlorination Plants Designed.

Laboratory: QUEEN BUILDING, HOLLIS ST.

HALIFAX, NOVA SCOTIA.

J. H. CHEWETT, B.A. Sc.

(Honor Graduate in Applied Science, Toronto University)

Assoc. Mem. Can. Soc. C.E.

Mining Engineer

Consultation. Reports. Development.

87 YORK ST., ROSSIN BLOCK, TORONTO.

BALBACH

Smelting and Refining COMPANY

EDWARD BALBACH, Jr. - - - President

J. LANGELOTH, - - - Vice-President

NEWARK, NEW JERSEY.

Smelters and Refiners of Gold, Silver,
Lead and Copper Ores.

Bullion and Argentiferous Copper Matte
received on Consignment or Purchase.

Smelting and Refining Works:

Electrolytic Copper Works:

NEWARK, N.J.

Buena Fe Sampling Works:

Agency, SABINAS COAHULLA.

John E. Hardman, S.B.CONSULTING
MINING ENGINEER,Room 2,
Windsor Hotel. **Montreal, Que.****20 Years' Experience in the Mining and Reduction of Gold, Silver, Lead and Copper.****13 Years as a Specialist in Gold Mining and Milling.****Dr. Alfred R. C. Selwyn,**

C. M. G., F. R. S.

Late Director of the Geological Survey of Canada and of the Geological Survey of Victoria, Australia.

Mines and mineral properties examined and reported on. Fifty years experience in Britain, Australia and Canada.

OTTAWA, CANADA.

JOHN B. HOBSON, Min. Eng. and Metallurgist. L. F. WARNER, Jr. Hydraulic and Min. Eng.

HOBSON & WARNER

Mining Engineers.

Twenty Years Practical Experience in California

Will examine and report on mining properties in Canada and the United States.

The Equipment and Opening of Deep Gravel Drift, Hydraulic and Gold Quartz Mines a Specialty.**QUESNELLE FORKS, BRITISH COLUMBIA.**

Agents for the Joshua Hendy Machine Works, Hydraulic and Mining Machinery, and the Well's Lights, for use in Hydraulic Mines.

REPRESENTED AT VANCOUVER BY

J. M. BROWNING,Corner Granville and George Streets,
Vancouver, British Columbia.**J. BURLEY SMITH**

Civil and Mining Engineer.

30 YEARS EXPERIENCE.**Glenalmond, Buckingham, QUEBEC.****Undertakes the Prospecting of Mines and Mineral Lands . . .**

Diamond Drill Borings made by contract for all minerals (earthy and metalliferous), Artesian Wells and Oil Springs, also Deep Soundings for Harbors, Rivers, Canals, Tunnels and Bridge Foundations.

Quarry Sites and Clay Fields tested.

Plans and Sections made showing result of Borings—Gold Drifts tested to Ledge by the new Pneumatic and Hydraulic Tube System and the yield ascertained—Flumes, Ditches, Monitors and Placer Mining Plant generally designed and constructed.

Properties Examined and Reported on and Assays made.

J. T. DONALD,

Assayer and Mining Geologist,

156 St. James Street, MONTREAL.

Analyses and Assays of Ores, Fuels, Furnace Products, Waters, etc. Mines and Mining Properties examined and valued.

WM. HAMILTON MERRITT, F.G.S.

Associate Royal School of Mines, &c.

Mining Engineer and Metallurgist

Will report on Mines and Mineral Properties.

ADDRESS:

15 TORONTO ST., TORONTO, ONT.**EDWARD C. HALL, Jr., S.B.**

Graduate of Mass. Institute of Technology.

Mechanical and Mining Engineer

MAPS, PLANS AND SPECIFICATIONS.

Examination of Mines and Mining Properties a Specialty

MINE CENTRE, SEINE RIVER, ONT., CAN.**WALPOLE ROLAND****Civil and Mining Engineer**

Reports, Surveys, Estimates and Development.

REFERENCES—Engineering and Mining Journal, New York; The Canadian Mining Review, Ottawa, and the Mining Journal, London, England.

CONSULTING ENGINEER.

OFFICE: LA SEINE RIVER, ONT.

Cable Address: "ROLAND," A1 Code.

M. FRANK CONNOR, B.A.Sc.

Grad. Faculty of Applied Science, McGill University.

Analytical Chemist, Assayer, Etc.

Accurate Analyses of Ores of Gold, Silver, Copper, Lead, &c., Furnace Products, Waters, Fuels, Etc. Special Rates to Mining Companies, Correspondence Invited.

OFFICE AND LABORATORY:

BANK ST. CHAMBERS OTTAWA.**A. H. HOLDICH**

NELSON, B.C.

ANALYTICAL CHEMIST AND ASSAYER.**FROM ROYAL SCHOOL OF MINES, LONDON.**

Seven years at Morfa Works, Swansea; seventeen years Chief Chemist to Wigan Coal and Iron Company, England, is now prepared to undertake every description of Analyses or Assays.

R. P. FRASER**MINING BROKER**

Dealer in Mines and Minerals

Expert at Diamond Drill Work

P. O. BOX 278

NEW GLASGOW, NOVA SCOTIA.**ORDWAY & CLARKE**

ROSSLAND, B. C.

Mining Engineers and Assayers

Contracts made for Underground Surveying and Assaying.

Specialty—Superintending Development and Reporting on Mineral Properties.

P. O. BOX 258.

HOWARD WEST

(Associate of Royal School of Mines, London)

Mining Engineer, Analytical Chemist and Assayer

THREE YEARS IN THE KOOTENAY.

Properties Examined and Reported on for intending Purchasers.

BELLVUE AVE., NEW DENVER, B.C.

A B C CODE.

G. A. GUESS, M.A.

H' A. GUESS, M.A.

GUESS BROS.**Analytical Chemists & Assayers**

Thoroughly familiar with Boundary Creek and Fairview mining districts. Mining properties examined and reported on.

Assays and Analyses of Ores, Fuels, Furnace Products. Etc.**Greenwood, B.C.****GWILLIM & JOHNSON**

[McGILL]

Mining Engineers and AssayersExaminations. Mining Surveys.
Drafting and Analyses.**SLOCAN CITY, B. C.****Von Schulz & Low,****ASSAYERS, CHEMISTS AND BULLION DEALERS.**

P.O. Drawer 1537. 1746 CHAMPA ST., DENVER, COLO.

Prices for Specimen Assays—Gold, Silver, Lead, or Copper, \$1.00 each; any two, \$1.50; any three, \$2.50. Complete price list and sample bags for mailing furnished on application.

**E. E. BURLINGAME'S
ASSAY OFFICE^A & LABORATORY**Established in Colorado, 1866. Samples by mail or express will receive prompt and careful attention.
Gold & Silver Bullion Refined, Melted and Assayed, or Purchased.
Address, 1736 & 1738 Lawrence St., Denver, Colo.**MICHIGAN MINING SCHOOL.**

A State School of Mining Engineering, located in the heart of the Lake Superior mining region, giving practical instruction in Drawing, Blue-printing, Mechanics, Mechanism, Properties of Materials, Graphical Statics, Mechanical and Electrical Engineering, Shop-practice, Analytical and Technical Chemistry, Assaying, Ore Dressing, Metallurgy, Plane, Railroad and Mine Surveying, Hydraulics, Mining, Mineralogy, Petrography, General, Economic, and Field Geology, etc. Has Summer Schools in Surveying, Shop-practice, and Field Geology. Laboratories, Shops and Stamp Mill well equipped. Tuition free. For Catalogues apply to the

DIRECTOR, HOUGHTON, MICH.

Canadian Rubber Company

OF MONTREAL,
TORONTO,
AND WINNIPEG.

CAPITAL, - - - - \$2,000,000.

Manufactures the Best Quality of Rubber Goods for Mining Purposes,
including

Rubber Belting ALL KINDS OF Rubber Hose

INCLUDING

"ROCK DRILL" SHOE, RUBBER CLOTHING,
RUBBER BOOTS, Etc., Etc.

ONTARIO BRANCH: Corner Front and Yonge Sts., Toronto.

J. H. WALKER, Manager.

M. BEATTY & SONS,

Welland, Ontario.

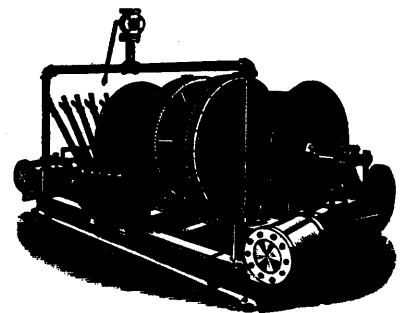

MANUFACTURERS OF

Dredges, Ditchers, Derricks and Steam Shovels
for Dredging, Dykeing, Ditching, GOLD
MINING, Etc., of various Styles and
Sizes to Suit any Work.

MINE HOISTS, HOISTING ENGINES,
HORSE POWER HOISTERS,
SUSPENSION CABLEWAYS,
STONE DERRICKS, GANG STONE SAWS.
Submarine Rock Drilling Machinery.

Centrifugal Pumps for Drainage Works,
Pumping Sand, Gold Mining,
Contractor's Use, &c.

WIRE ROPE AT MARKET PRICES.

WM. HAMILTON MFG. CO.,
Agents, Victoria, B. C.

STEEL

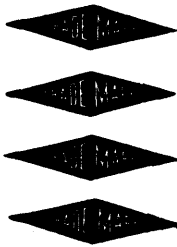

"BLACK DIAMOND" STEEL

... FOR ...

MINING DRILLS AND ALL OTHER PURPOSES.

If Your Dealer Does not carry it, Write

PARK BROTHER & CO., Ltd.

337 ST. PAUL STREET,

MONTREAL.

Pumps & HYDRAULIC MACHINERY

STOCK SIZES ALWAYS ON HAND.

Drawings and Estimates Promptly Furnished.

THE NORTHEY CO. Ltd., Toronto, Ont.



The Canadian MINING REVIEW

Established 1882

Official Organ of the Mining Society of Nova Scotia; The General Mining Association of the Province of Quebec; The Asbestos Club; and the Representative Exponent of the Mineral Industries of Canada.

B. T. A. BELL, Editor and Proprietor.

Published Monthly.

OFFICES (Slater Building, Ottawa;
Metropole Building, Halifax;
Windsor Hotel, Montreal.)

VOL. XVI, No. 8.

AUGUST, 1897.

VOL. XVI, No. 8.

The Yukon Mining Laws.

In view of the great diversity of opinion which has been expressed with regard to the Yukon mining regulations recently adopted by the Dominion Government, we have pleasure in submitting the following notes, contributed to the REVIEW by Dr. Rossiter W. Raymond, Secretary of the American Institute of Mining Engineers, and probably the greatest living authority on mining law. Dr. Raymond says:

"I have examined with interest the regulations governing placer-mining along the Yukon river and its tributaries in the North-West Territories, approved by Order-in-Council No 1189, of May 21st, 1897, as amended, of which you kindly sent me a copy. In presenting a few comments upon them, I will follow the notes made in reading under the different heads.

Interpretation—At first sight, the preliminary definition of the terms to be employed in the regulations seems to be an excellent thing. But on further consideration, I am inclined to question whether it does not introduce new difficulties in construction. At all events the "interpretation" ought to be consistent with the following text, and ought not to carry unintentional limitations. Under these texts, the "interpretation" before me does not seem entirely satisfactory.

"Bar diggings" are so defined as to exclude everything below low-water mark. "Creek and river claims" are not defined, but the subsequent description of them would apparently include bar-diggings. Since they may be much larger than the bar-digging claim, and the fees and royalties required are independent of the size of the claim, a miner might, apparently, better take a creek or river claim at once, and thus secure the right, not only to work the bars (or ground between low and high water) but also to turn the stream, or put in a cofferdam, and work the bed itself, which might in some places be the richest part. Again, if a bar-digging has been granted, it is impossible, under the terms of the regulations, to grant to another person a river-claim at the same point; and since the same person cannot receive a second grant in the same locality, it looks as if the river-claim was "barred" altogether. Of course, this difficulty can be arranged in practical administration. But it would have to be done by disregarding the letter of the regulations. In other words, the attempt to define so carefully as to leave no doubt has broken down.

"Claim" is defined to be "the personal right to property in a placer-mine or diggings," etc. But the regulations use the term in a totally different sense, which makes the preliminary "interpretation" absurd. A man can scarcely talk of the "size" of a personal right, or say it shall be 500 feet long, or that its sides shall be parallel lines. Nearly every reference to claims in these regulations (except as to

the recording of them) means by "claim" a tract of ground. Moreover, if two persons should become joint-owners of a claim, each would have a "personal right," and there would be two "claims." The preliminary definition is superfluous and misleading.

"Close season" is defined; but this seems to be an act of gratuitous generosity. The word does not occur afterwards in the regulations.

"Locality" is defined as the territory along a river (tributary of the Yukon river) and its affluents. That is to say, the whole watershed of any tributary of the Yukon in one "locality." Is it really intended by Regulation 16, forbidding more than one grant to the same person in the same locality, to prevent a miner from trying his luck, first on one stream, and then on some other tributary to it?

A term of some importance which does not receive any preliminary interpretation is "surface rights." The regulations and the annexed form of grant give to the grantor the exclusive right of entry upon his own claim, and the right to work it, and to construct a residence upon it, but he shall have no surface-rights therein. Probably "no other surface-rights" is what is meant. It is not likely that a back-yard is forbidden; doubtless the question of a kitchen-garden would not arise in that latitude; and it is somewhat amusing to find the miner, after he has received all the surface rights that are worth anything, declared not to possess any.

Right of Way.—In this connection, I may call attention to the only provision which limits the miners' exclusive right of entry, namely, the authority given to the Gold Commissioner to "grant to the holders of adjacent claims such right of entry thereon as may be absolutely necessary for the working of their claims." This authority is too narrow. It is not only "adjacent" claims which may need, and ought to have, such a right of way; and it is not only when "absolutely necessary" that such a right should be granted. The Gold Commissioner should have full discretion to grant the right of way when its exercise is decidedly advantageous, or reasonably desirable, to the applicant.

Nature and Size of Claims.—If bar claims are large enough, when only 100 feet long, 500 feet seems to be too much length for creek-claims, except on very small streams indeed. The Yukon and its tributaries differ, however, it must be confessed, from gold-bearing streams further south. They do not shoal by reason of dry weather, but rather through the freezing of their head-waters and side-supplies. The Yukon itself falls rapidly in August from this cause, and the smaller streams which flow into it must shrink at the same time. Probably the difference between high and low water is very great, so that bar-claims of 100 feet are long enough for single miners. That used

to be the length of gulch-claims on our Pacific coast, and it has the advantage of giving claims to a larger number of adventurers, although, as a matter of fact, the consolidation of such claims is necessary to their advantageous development.

Fees and Royalties.—There can be no doubt, however, that the entry fee of \$15 for the first year, and of \$100 for each following year, in addition to the royalty of ten per cent. and upwards upon the product of each claim, is a very severe requirement, especially when the small size of the claims is considered. I admit freely that the Government of the Dominion has a perfect right to make whatever terms it chooses in this matter, and I confess that this case differs widely from that of our Pacific coast, where the liberal terms granted to mining have made ample returns in the establishment of permanently prosperous communities, in many of which mining is now a subordinate industry. The Klondike settlers do not go to stay. Their purpose is to rob the region of its treasure, and then go home again, leaving it uninhabited as they found it. The government would therefore reap nothing from its liberality if it should give away, free of royalty, the gold in its Arctic lands. A reasonable revenue, covering the cost of the administration of justice, order and civilized organization, and even furnishing something to the Treasury besides, may well be required of this new and destructive industry. But the exactions of these regulations are not reasonable. The requirement of \$100 per annum anyhow is unwise and unfair. If a miner succeeds in extracting gold from his claim, the royalty he pays should be satisfactory to the government; if he does not succeed at first, why should the government discourage him from persevering? Its interest is that he shall go on and test his ground thoroughly. Its policy should be to encourage prospecting and tax the proceeds, not the endeavor.

Not only are the fees and royalties too large, but they are unnecessarily multitudinous. Permits for this and that privilege, which might well be included in the very expensive privilege of mining at all, require separate applications and fees, until the whole thing reminds one of a high-priced boarding school, where music and dancing and a pew in church are, nevertheless, "extras."

It would certainly be difficult to enforce these regulations, and it is possible that all the revenue derived under them would be required to administer them, so that the government might find that it would have been better off if it had encouraged, instead of oppressing, the mining communities. The fable of the goose that laid the daily golden egg would be quite in point here; only I hardly think this particular goose is as permanently valuable as its classic prototype. The virgin riches of the Yukon territory are not going to last forever, or even very long. There is nothing new under the sun. We have seen plenty of these placer-mining rushes: and the Klondike will prove like the rest. There will be large returns in some places and to some men, and sore disappointment to thousands; and after awhile there will be a sickly, waning activity, needing every encouragement, and not able to bear heavy taxation. The worst thing that can be done is to force the working of the richest ground and the abandonment of the rest.

As I write, I hear a rumor that the Dominion government has been induced to reconsider these regulations, and that more lenient ones will be substituted. I trust this is true, and that in the new scheme the entry fee will be small, and the annual payment, irrespective of product, will be omitted altogether.

I cannot close without recognizing the characteristic liberality of these regulations in one respect, namely, the total absence of discrimination against aliens, who are treated exactly like native citizens. If the American miners who are crowding to the new Eldorado were compelled to forswear their allegiance to the United States on a condition

of holding mining claims, they would suffer what our foolish patriotism has inflicted upon foreigners for many years past. It is a silly measure, and more annoying than effective.

NEW YORK, Aug. 12, 1897.

R. W. RAYMOND.

Since the above was written, a copy of the amended regulations was forwarded to Dr. Raymond, who writes: "The changes you mention leave the system still objectionable, in my judgment. And the reservation of alternate claims, which I did not mention in my article, is a measure of doubtful expediency—though I will not absolutely condemn it without knowing more of the facts. If they are promptly sold at auction by the government, that may prove to be the fairest way to handle them; but for the government to hold onto them and not have them worked, would, I think, be unfortunate."

We may have something further to say on these regulations in our next number.

The Yukon District.

More than ten years ago, when placer gold mining along the tributaries of the Yukon in Canadian territory began to attract some attention, the Government decided that it was advisable to ascertain what importance might attach to this mining, and approximately where the 141st meridian, constituting the boundary between Canada and Alaska ran through the territory. The writer was entrusted with the charge of an exploring expedition to the region, and after obtaining all possible data from the few persons who had already visited some parts of it, the Yukon expedition left Ottawa early in the spring of 1887. Mr. W. Ogilvie was associated with the expedition and was particularly charged with the determination of the boundary line.

Many years before, the Hudson Bay Company had explored certain routes through this northern country lying west of the main Rocky Mountain range, and had established fur trading posts there. The history of these explorations now reads like a romance, in which the chief figure is the late Mr. Robert Campbell, who, up to the time of his death maintained the greatest interest in the further exploration of the region, and in correspondence with the writer afforded information which very materially assisted in enabling the exploration of 1887 to be carried to a successful issue.

The extension of the fur trade and the discovery of routes by which the supplies necessary for this purpose could be maintained, were the main objects of the early explorers, though some of them, like Campbell, kept careful diaries and journals, and furnished valuable contributions to general geographical knowledge. They did not discover the golden sands over which they were drifting along these great rivers, nor did they even know, until 1850, that the Pelly, the Lewes and the Yukon were continuous with the Kwitchee of the Russian fur traders on the coast. In 1852 the first-discovered routes across the upper Yukon basin were abandoned by the Hudson Bay Company in favor of that by the Porcupine River, and because of changes in the course of trade, and for many years the Lewes, the Pelly and their numerous tributaries appear to have remained unvisited by whites.

The history of the exploration of the Yukon district must, however, be told elsewhere. In 1880 some prospectors began the search for gold, and in the summer of 1887 there was about 250 miners in the region, most of them, at that time, being at Forty-mile Creek, where "heavy gold" had just been discovered.

In my report on the exploration of that year the general features of gold mining were thus summarized:—

"Forty-mile Creek is what the miners term a 'bed-rock creek' i.e., one in which there is no great depth of drift or detrital deposits

below the level of the actual stream. It is so far the only locality which has been found to yield 'coarse gold' but from the extremely wide distribution of 'fine gold,' it may safely be predicted that many more like it remain to be discovered.

"Mining can scarcely be said to have begun in the region more than five years ago, and the extent of country over which gold has been found in greater or less quantity is already very great. Most of the prospecting has been confined to the banks and bars of the large rivers, and it is only when their innumerable tributary streams begin to be closely searched, that "gulch diggings" like those of Dease, McDane and other streams in the Cassiar district, and possibly even on a par with Williams and Lightning creeks in Cariboo, will be found and worked. The general result so far has been to prove that six large and long rivers, the Lewes, Teslin too, Big Salmon, Pelly, Stewart and White, yield 'fine gold' along hundreds of miles of their lower courses. With the exception of the Lewes, no part of the headwaters of any of these have yet been prospected or even reached by the miners, and scarcely any of their innumerable tributaries have been examined. The developments made up to this time are sufficient to show that when means of access are improved, important bar-mining will take place along all these main rivers, and there is every reason to anticipate that the result of the examination in detail of the smaller streams will be the discovery of much richer auriferous alluviums. When these have been found and worked, quartz mining will doubtless follow, and the prospects for the utilization of this great mining field in the near future appear to me to be very promising."

With some knowledge of the geological conditions and history of gold mining in the corresponding region included in British Columbia to the south, a forecast of the kind became perfectly safe, and subsequent events have more than verified it. Mining was first successfully extended to various tributaries of Forty-mile Creek, then to a number of branches of Sixty-Mile Creek, further to the south, and the late phenomenally rich discoveries on Klondyke River have drawn universal attention to the entire district.

We have as yet no technical details of the actual mode of occurrence of the gold on the Klondyke and its tributaries, but it is safe to assume that it is here, as elsewhere, contained in the lowest gravel deposits of these valleys, at a certain depth below the level of the existing streams. "Coarse" or "heavy" gold, is never found in quantity at a distance from its place of origin, and if the rich placers of this locality should be found to extend for more than a few miles along each of the valleys, it will be an exception to the general rule. The fact that the ground is frozen beneath the superficial covering of moss and soil, although it affects the methods to be employed in mining, does not necessarily show that the deposits are different in character from those met with elsewhere, for, at the time when the greater part of the erosion and concentration of gold occurred, the climate of this whole region was undoubtedly much more genial than it is now. A similar state of affairs was found in the Cassiar district of British Columbia, which though further south is at a higher altitude, but after the forest and moss had been cleared away, little further complaint was heard of frozen ground.

The fact that a number of rich "bed rock" creeks, including Forty-mile, Sixty-mile and the Klondyke, with their tributaries, have been found in a portion of the Yukon district not more than 100 miles in total length and all within a short distance of the main river, indicates that the district as a whole must now be regarded as one of remarkable promise for further discoveries of the same kind. To what parts of the region, with its countless streams, the attention of the prospector may next be most profitably directed, is a question of importance. In British Columbia, we know that the richer placers,

beginning with the Kootenay district, and continuing in Cariboo, Omenica and Cassiar, follow a belt of country to the south-west of the Rocky Mountains proper, but nearer to the mountains than to the Coast Ranges. The geological conditions are very similar throughout this belt, and are again the same, so far as known, in the tract running from Cassiar, to Forty-mile Creek, including the Klondyke as well as much of the drainage-basins of the Stewart, Pelly, Big Salmon and Teslin-too. In the numerous tributaries of these rivers, then, the search for further local deposits of "heavy" gold may, it would appear, be prosecuted with the greatest chances of meeting with further discoveries.

Much of the Yukon district is by no means the Arctic region that it is often pictured. Hardy crops can, and now will be grown in it. Much of it is well wooded and along the lower valleys the timber, generally spruce, attains a fair size. Efficient means of communication once provided, the mineral wealth of the district will be exploited with greater facility than that of the woodless and waterless regions of Arizona. Exclusive of one important break, caused by the White Horse Rapids and Miles Canon on Lewes River, there is on the Canadian side of 141st meridian, a connected water communication available for stern-wheel steamers of over 1000 miles, and after passing other obstacles on the various great rivers, there are many additional long water-stretches. The immediate difficulty to be faced lies in the fact that the communication is almost entirely by water, and that no matter what efforts may be made to place supplies on the rivers, the small number of steamers at present available will be unable, before the onset of the long and severe winter, to carry these to the points to which the streams of miners are trending. Thus it is that much suffering and even absolute starvation may occur in the district, and that it is absolutely impossible to prevent this with the existing facilities if a large number of men carrying insufficient supplies with them congregate in the mining camps. With a scarcity of food there can be no work and no high wages for the man without independent resources. All claims of value along the streams already proved to be rich will be found to be taken up, and it will be practically impossible for him to travel in search of new ground during the winter.

Before the spring, preparations will undoubtedly be made such as to meet all requirements of the incoming miner, and during the summer of 1898 much of the district will be prospected for placer deposits. The requisite means of transport will be provided, and before long the veins and lodes from which the alluvial deposits have been derived, will be discovered and worked. The present rich finds, particularly available to the individual with little capital besides enterprise and muscle, will afford the necessary incentive to the opening up of the entire country, and in my opinion, the development of quartz mining in the Yukon district, although, it may precede will not long antedate the establishment of a chain of permanent mining camps extending from Kootenay to the inland boundary of Alaska.

GEORGE M. DAWSON.

British Columbia's Company Laws.

Many American critics, connected with Western mining, as also some few British promoters or would-be promoters of mining companies, intended to operate in British Columbia, complain more or less loudly of the amendment and consolidation of the Provincial Joint Stock Company laws, recently effected by the Legislature, in pursuance of recommendations made by a special committee of the House. This special committee consisted of Attorney-General Eberts, Mr. H. D. Helmcken, Q.C., and Messrs. Rithet, Cotton and Sword, five of the ablest men in the Legislature, together representing "both

sides of the House," and in addition deemed by their fellow members in general to be specially adapted for the duty entrusted to them.

The Attorney-General and Mr. Helmcken represented skilled legal opinion. Mr. R. P. Rithet, as one of the shrewdest and most successful business men of British Columbia stood for the capitalist and commercial element of the community. Mr. Cotton represented wide English and Western-Canadian business experience, including journalistic training, and also brought to bear upon the investigation knowledge of Western-American mining law requirements, as exemplified in the course of residence and business life for several years in the solid, silver-yielding State of Colorado. Mr. Sword finally stood, by general consent of the House, for a man of shrewd and sturdy common-sense, and a member noted for keenness in detecting statutory flaws and omissions.

It was unlikely that such a committee would wholly fail in an endeavor to remedy notorious defects in a system of company laws, which was, before the passing of amending legislation on their report, extremely lax, by reason chiefly of the omission of safeguards found necessary or desirable in other commercial and industrial communities of Great and Greater Britain.

The members of the special committee naturally took for their chief model the Joint Stock Company laws of the United Kingdom, as codified and recently amended, knowing that these, although by no means free from inherent defects, and in some details inapplicable to the conditions of industrial life in a new western land, had fairly stood the test and served the purposes of the foremost commercial nation of the world—a nation, moreover, noted for the number and variety of its mining companies, organized for operating mineral claims of all kinds at home and abroad.

It will, therefore, be found that the new company law system of British Columbia largely follows the line of like British legislation, whilst it will be found also, that in the main provisions which relate to mining organizations, much care and attention have been paid to adapting the general rules of British company law to the peculiar circumstances, and special, and in some cases traditional, usages of western mining incorporations. The new company law thus formulated can, and doubtless will, be amended from time to time, as practical experience may direct, in many details, but it will on examination be found that the points in it whereof its critics most complain are specially designed to remedy abuses widely prevalent under the former system. The remedy has, moreover, in several instances already proved equal to its occasion, and abated the evil attacked.

A company can be formed in British Columbia by the signature of a memorandum, or memorandum and articles of association, by five persons, instead of seven as in England, on payment of registration fees and filing of the usual particulars under joint stock company systems. The registration fees have been raised, and of their amount many complaints are made, but the fees, which are *ad valorem*, have been adopted with a view to prevent notorious abuses which grew up under a custom of nominal over capitalisation of mining companies, issuing stock at a huge discount as "fully paid and non-assessable." Companies thus formed in many cases deceived unwary small investors into an unfounded belief that they were getting quite exceptional value for their money, whilst in reality such companies were but too often organized under conditions absolutely fatal to the success of the mine venture, and profitable only to promoters, brokers, printers and others, concerned in flotation.

To prevent such deceptive and unreal over capitalisation, a fee of \$25 is charged for the registration of a company with capital not exceeding \$10,000. On each \$5,000 of further nominal capital up to a total company's capitalisation of \$25,000, a further fee of \$5 for each

\$5,000 of capital is charged; and on further capitalisation between the first \$25,000 and \$500,000 in all, \$2.50 for each \$5,000 of nominal capital; whilst for every \$5,000 after the first \$500,000 of authorized company capital, a registration fee of \$1.25 is charged.

The object of this provision—which object has been achieved almost completely—is to prevent the continuance of a system of forming mining companies, nominally capitalized in a big sum of \$1,000,000 or upwards, whatever the inherent value of the claim or claims sought to be worked, and whatever the actual capital needs of the venture. Nearly 1,000 such companies were hurriedly formed in British Columbia during the recent mining boom, of which companies hardly one in ten has got effectively to work, whilst more than half either died still-born or failed even to secure enough capital to pay printing, registering and preliminary office expenses. The usual *modus operandi* was to form a company in a million dollars, and then offer stock as fully paid at from two to five cents on the dollar, subject often to a deduction of from 20 to 33 per cent. for broker's commission, and to other large office and advertising expenses. In a number of cases the net amount thus realized was not more than from \$5,000 to \$10,000, on either of which sums it is usually impossible to develop a British Columbia precious metal claim or group of claims. These on an average require the expenditure of at least \$25,000 of capital, and in many cases of \$50,000 and upwards, ere the properties begin even to ship, although there are instances, especially in the Slocan, where in consequence of mines paying from the grass roots, a very modest expenditure of money or money's worth in labor suffices. Poor people here and in Eastern Canada were tempted to believe that in the case of such "million dollar" companies they were getting a real dollar's worth of stock for two to five cents, instead of which they were in most instances paying for worthless scrip, since on stock issued at such enormous discounts there was too often realized, as already stated, a sum insufficient even to make a beginning of development. The *ad valorem* registration fees of the new Act have knocked on the head most projects for the future formation of such gull-catching mine companies, and caused most undertakings that are now registered to be issued with a moderate but sufficient authorized capitalisation, and with stock that is not issued at such a big discount, as discount altogether the undertaking's chance of success. A mining company in British Columbia is now usually issued at a capitalisation nearer \$100,000 than \$1,000,000, and the two and five cent on the dollar stocks have given place to more reasonably issued stocks, for which from 20 to 50 cents on the dollar are usually asked, and from which, after deducting necessary commissions and other expenses, a sufficient sum can be derived to give the company, if honestly organized and properly worked, a fair chance of making something of its properties. Thus the somewhat high *ad valorem* fees of British Columbia company registration at the present have contributed fairly to provincial revenue, and also remedied a gross abuse, seeming detrimental to the poor and unskilled small investor. They have nevertheless been freely denounced, but for the most part by American and other would-be promoters of wild-cat, catch-penny ventures, either altogether illegitimate or nearly so.

Having regard to the fact that much mischief had been done by the issue of stock at a large discount, yet declared "fully paid and non-assessable," the select committee which prepared the Act had many doubts whether it should legitimise in any form the practice of issuing shares, deemed to be fully paid at any discount of their face value. It was, however, ultimately decided, in view of the generality of the practice in Western Canada and the Western States, to permit companies thus to issue discounted stock. Safeguards are, however, provided by the Act, against the deceptions of creditors and others by such issues, when either made by provincial or extra-provincial com-

panies operating in B.C. The discount-issued stock must be marked "non-assessable," and on all notices, orders, agreements, bills of exchange, notes, endorsements, cheques, and on the common seal of such discount-share issuing company, there must be added the words "non personal liability," to show those trusting the company that they have only to rely for assets on the capital paid up and general property of the undertaking, and can safely give no credit to the company on the supposed financial status of its members. A penalty of \$20 a day in default enforces this proper safeguard.

The Act also provides that without prejudice to creditors' rights accruing anterior to the passing of the Act, any discounted shares issued as "fully paid up and non-assessable" by any duly incorporated company shall involve the holders in no further liability.

A special and useful check on malfeasance by officers of a company is provided by clauses, enabling government inspectors to examine fully on oath into the affairs of any company, and report publicly thereon, upon the request of members of a company, owning a fifth part of its shares issued, and in the case of a company seeking to reduce its capital, the safeguard provisions of the English law are introduced.

Extra provincially organized companies operating in B.C. must, in the case of British, Irish or Canadian organization, obtain a license, and in the case of foreign bodies register in B.C. in each instance, paying the same fees as if a home organization seeking first registration. They must also each file a copy of the charter, with a declaration of *bona fide* existence, and a copy of the last balance sheet, together with the auditors' report, and also appoint an attorney, residing in the district of the head of office of the company in the province, who is to accept service of documents, sue and be sued, and act as a general agent of the company for legal and other official purposes in B.C.

Objection is taken, not without some reason, to the fees charged for registering or licensing an extra-provincial company in the province, these equalling the cost of first registration, and being additions to like costs incurred at home by the extra provincial companies. But against this plea, it may with some force be urged that it is not wholly illegitimate for the company laws of the province to afford a stimulus in some such way to the original registration of a company intending to operate in the province, directly under the company system of such province. It tends to advance provincial home rule.

Another provision, to which much exception has been taken, requires an extra-provincial company to have a head office in B.C., and there keep a register of stocks and transfers amongst other matters. This requirement is surely not however unreasonable *per se*, and it may well have the result, no doubt indirectly sought in the Act by this and other means, of transferring to B.C. much head office and managerial business, which is now transacted abroad by extra-provincial companies, especially in such American mine centres as Spokane. B.C. desires its own mine centres to become, so far as possible, the sites of general head offices, and thus not only keep business at home, but also enable local investors to scrutinize more effectively the conduct of concerns in which they are interested. In more than one instance of an extra-provincial company, the rights of British Columbia stockholders have been rather ruthlessly treated in sale and other negotiations, held in hole and corner fashion by directors meeting far away in the States. Such things will in some measure be rendered more difficult under the Act.

The Act also contains valuable penalty provisions for safeguarding the interests of creditors and shareholders and for punishing fraudulent misrepresentation of paid up capital and other malpractices, so too for winding up companies, but these are too lengthy to quote in the limits

of a short criticism of a measure, mainly intended to discuss certain issues more specially raised by adverse critics. A careful examination of the Act will, however, convince an unprejudiced and unbiased reader, who has some experience of company management, that its provisions are on the whole sound and well intended and form at least basis on which ultimately to build an efficient company law code for British Columbia. Where the provisions differ materially from well established and well tested prototypes, there will usually be found special local reason, based on recent experience for the innovation or innovations.

And after all the chief critics of the measure are found amongst would be wild cat company promoters and amongst mining men from the other side, who are in company laws as in other matters of legal procedure inclined to favor rules that are somewhat inclined to err in the direction of laxity of safeguard of the general public interest. Here and there the British Columbia company law in following largely the precedent of England, may be found a little too minutely circumscribed to suit western circumstances exactly, without causing by technicality of procedure some slight occasional inconvenience, but the general tendency of the legislation in question is undoubtedly in a right direction.

In conclusion it may be noted, that under special mining legislation, a British Columbia precious metal mining company must take out a miners' license in \$50 a year, if capitalised at \$100,000, or under and one of \$100 if capitalised in a sum above that amount. The levies in these cases are by some deemed high, but surely neither can be regarded as a very large premium asked by the Province for the valuable privilege of seeking the precious metals. It is said that some companies cannot afford to pay these licenses, but if so, assuredly it is better for them to quit a field, which assuredly they enter in any such case, with capital altogether inadequate for success. It takes necessarily as a rule no little gold and silver to get out gold and silver.

EN PASSANT.

Our West Kootenay correspondent Mr. J. C. Gwillim, B.A. Sc., M.E., at Slocan City, B.C. is, we regret to learn, seriously ill with an attack of typhoid fever.

Mr. William Blakemore, M.E., of Glace Bay, C.B., has gone to East Kootenay to report on some valuable coal and mineral lands in the Crow's Nest Pass.

Mr. John E. Hardman, S.B., M.E., Montreal, who has been in British Columbia all summer returned last month. Mr. Hardman goes to East Kootenay on 1st September.

The directors of the Londonderry Iron Company are endeavoring to sell their property in Cumberland county, Nova Scotia. A reconstruction of the company is not unlikely. The last statement to the shareholders showed:—

| | |
|---|-------------|
| The amount at debit of Profit and | |
| Loss from 1895 was..... | \$60,306.47 |
| And the result of the partial operations carried on during 1896 has been: | |
| Loss during six months ending 31st | |
| December, during the greater part | |
| of which the works were idle..... | \$15,220.60 |
| Less gain on working for six months | |
| ending 30th June, 1896..... | 6,285.27 |
| Loss on the year..... | \$8,935.33 |
| Carried forward at debit of Profit | |
| and Loss for 1897..... | \$69,241.80 |

Prof. N. S. Shaler, of Harvard University, has been in Caribou, Nova Scotia, for a number of weeks engaged in examining the low-grade gold ores. With him are a number of Harvard men, who are taking advantage of the opportunity to learn something about the mineralogy of that province.

A very important decision has been given by the House of Lords in reference to the issue of shares at a discount. A previous judgment, that in the Ooregum case, had established the fact that holders of shares issued at a discount were liable, to the extent of the discount at which they had been issued, to contribute to pay the debts of a company and the cost of liquidation. The judgment now recorded goes a step further, and says that such shareholders must pay up, even after all liabilities and costs have been satisfied, so that a fair distribution of the surplus assets may be made to the whole body of shareholders. This decision is the logical sequence of the Ooregum case; for surely, if the obligation to make good the discount exists, it should exist for all purposes. It is a hard case for those who took discount shares with every apparent assurance that they were guarded from all claims; but the more logical and complete the law is, in such points the better it is in the long run. The decision was given on the appeal of a shareholder against a call made by Mr. T. A. Welton, liquidator of the Railway Time Tables Publishing Co., on J. J. Saffery, a shareholder, who held 215 bonus shares, two of which had allotted as paid up to £5 each to each person who took up a £10 debenture. An issue of 5000 new shares was also made, at 90 per cent. discount, each share of £5 being allotted as fully paid up in respect of a cash payment of 10s. Of these he held 4460, and also 568 preference shares. Lord Herschell differed from his brother judges on the grounds that the transaction had been agreed to by all the shareholders, and that he thought it more consonant with recognised principles to hold the members bound, and the transaction, valued so far as the statute did not expressly invalidate it. The Lord Chancellor, however, said that it seemed to him, however hardly it might operate upon individuals, to be a just and right thing that those who had completely discharged their statutory obligations should have a right to call on the other shareholders to do as they had done, and pay what was due on the shares in order to settle the rights of the shareholders *inter se*. The decision will add to the terrors which already beset persons who are induced by the offer of discount or bonus shares to assist a company in difficulties.

Mr. Thos. Tonge, to whose writings in the *London Mining Journal* we referred editorially some time ago, has another strong article on the monuments to buried English capital in the Western States. He points out that the failures he enumerates can fully be attributed "to the neglect of the ordinary precepts of mining, to lack of business prudence, or to the ambition that possesses many men who embark in mining enterprises to prove themselves wiser than the knowledge that has been accumulated by years of scientific investigation and experiment the world over, and which is transmitted in the course of his studies to every well trained mining engineer or metallurgist."

His remarks are very applicable to many mining investments in Canada where the crop of bumptious amateurs—incompetent and irresponsible persons, ignorant of their own ignorance—has not yet failed. Large sums are being spent on the development of mining properties and the erection of ore treatment plants, where the inexperience and reckless self-sufficiency of the local managers are so pronounced that financial loss is almost guaranteed to the persons furnishing the capital. Mr. Tonge's concluding remarks are so pertinent that we may be excused if we reproduce them in full. He says:

"Colorado to-day has a number of professional men, (1) mining engineers, (2) metallurgists, (3) experts combining a thorough knowledge of mining and mechanical engineering and metallurgy.

The latter, besides examining and reporting on mining properties, designing and estimating, smelting, and other ore treatment works, and hoisting and pumping plants for mines, devote considerable attention to the subject of the best treatment of ores. The proper treatment of low grade ores, more especially, is becoming more and more imperative for the Western miner. The usual practice, heretofore, as above shown, has been to erect a plant of some sort, only to find, perhaps, after from £5,000 to £10,000, or even more, has been spent that the machinery and appliances introduced were not adapted to the purpose required, and even that the ore itself was unfit, by reason of character, for the process to which it was subjected. Such lamentable and expensive mistakes can easily be avoided, as these experts are prepared to make tests on a small scale, the results of which will be borne out by those that will be obtained on a larger scale in practice. In other words mine owners can have their ores tested, and the exact character determined, knowing exactly what saving of precious and base metals can be effected, and what processes and appliances are best adapted for the treatment of such ores. The same expert will design plans and obtain estimates for the necessary plant, and supervise its correct and honest construction.

Apart from the solid, valuable, and money saving advice so obtained, such an expert represents and protects the interests of the capitalist as against the interests of the mill builder and machinery man, in the same way that an architect protects the interests of the home builder as against the interests of the contractor and builder. It is a well recognized fact that the employment of a competent and honourable architect fully saves the amount of his bill in the superiority of the arrangements, material, workmanship, and reduced cost of the house built. So also, but in a much greater degree, with the complicated and ever varying question of mineral-bearing ore, and its most effective and economical treatment."

A United States paper—many wonderful stories are contained in American papers—is responsible for the statement that one Benjamin Brazelle, a chemist and inventor, of St. Louis, has made a discovery, which, if substantiated—the "if" is a very important member of the sentence—will render the pursuit of mining useless and unnecessary. From common clay he claims that he can turn out gold, silver, iron, calcium, aluminium, and a number of other metals as yet unknown to science. He asserts that his investigations have demonstrated that there are but three primary metals—copper, lead, and iron—which cannot be separated into component parts, and that the teaching of chemistry that there are 75 such metals is a mistake. He believes that by his process gold and silver will be turned out in such large quantities that all governments will be compelled to demonetise them. In the meantime there does not appear to be much immediate danger of such a consummation, as it is announced that the company which has been formed to work Mr. Brazelle's process will at first pay little attention to the manufacture of gold and silver, "as these two articles will cost more to manufacture than they can command on the market." The concern will, at the beginning, confine itself to the manufacture of aluminium, calcium, gladium, and zesium, one of the new metals, which Mr. Brazelle says is destined to take the place of steel. We are far from asserting that science has said her last word as to the simple or compound nature of any of the bodies to-day accepted as elementary, but we don't think that miners are likely to be compelled to slacken their efforts yet awhile for the production of the metals, precious or otherwise. A short time ago, it will be remembered, a New York

scientist claimed to have succeeded in transmuting silver into gold by a secret process. No quotations, however, have as yet been published respecting the market price of the gold from this new source of supply. The miner still commands the situation, and is likely to do so for a long time to come.

A fool there was, and his house he sold,
 (Even as others have done!)
 And went out West to the Klondike cold,
 Intent on digging for gold, bright gold—
 But, oh, my friends, he got sadly sold,
 (Even as others have done!)
 Oh, the frost he fought, and the turf he turned,
 And the work of shovel and pick
 Brought him 'nary a nugget of gold;
 And the heart that was once so hopeful and bold,
 Soon grew both weary and sick.
 He made a great deal less than he spent,
 (Even as others have done!)
 And honor, and faith, and a sure intent,
 He lost along with his very last cent—
 And now he is sorry that ever he went,
 (Even as many another one!)
 Oh, the toil so hard, and the spoil so scarce,
 And the claims that poorly "panned,"
 And the digging down in the frozen earth,
 And the working away for all you're worth,
 And the getting nothing but sand.
 The fool got sick of his foolish quest,
 (Even as others have done!)
 So he cursed his luck, and the wild Nor'-West!
 And he struck out for home with a wondrous zest,
 To become of his fellow men the jest,
 (Even as others have done!)
 And it isn't the shame of skipping his claim,
 That makes him feel like a freak—
 It's coming to know that the gold was there,
 (Learning at length of fortunes made there)
 Where he couldn't strike a streak.

One of the most interesting sights in the great mining town of Butte, says the *Anaconda, Montana, Recorder*, is the process by which copper is caught from the emerald-colored water that flows from the Anaconda and St. Lawrence mines. It is estimated that this water, which for four or five years went to waste, is now bringing the Anaconda Company £6000 a month, at a cost of about £200 a month. It is only within the present year that the company undertook to handle this water. Heretofore it was worked under lease. An old German, named Mueller, was the first man to save copper from the water. During the last three years Thomas Ledford had a lease of the water. He paid a 25 per cent. royalty to the company. It is claimed that he realised at least £20,000 a year from the water. Ledford is a pretty rich man to-day. Now that the company is operating the waters on its own account, it has discovered what a great money-making enterprise it is. At the present time several acres of ground are covered with wooden vats. These are filled with all the old scrap-iron they can hold. It has proved a splendid scheme for disposing of the tons and tons of old iron the company has accumulated for years. Old hoisting cages, water-pipe, wheelbarrows, railroad

iron; in fact, any old thing that consists of tin or iron is appropriated to this service. It is said for every pound of iron put into a vat a pound of copper is produced. Where the water first attacks the iron the copper absorbs the iron completely within three weeks. After the precipitation is affected, the water is drawn off and the slimy copper is transferred to another tank, where the water is further drained off. These latter vats hold about fifteen tons of copper, which now has the appearance of a clayish substance. This is sacked into packages of about 100lb. When in this shape it is sent to the smelters. The product carries an average of 86 per cent. pure copper. The iron remaining in it makes a fine flux, and, when mixed with other smelting ores, it is said to bring the ore up to a value of about £60 a ton. The water from the mines is the most profitable product of the Anaconda Copper Mining Company.

An apparatus has been invented by Mr. Joseph Thomson, of Cardiff, for measuring the quantity of air passing in mines. By the adoption of this instrument it is claimed to be practicable for any man or boy of average intelligence, by merely actuating a switch, to ascertain with scientific precision the volume of air passing any point fixed upon by the management. Thus: A transmitting instrument may be permanently fixed in the fan drift of a colliery and the indications of the quantity of air taken by the fan engineman—who usually is only partially employed—or by a clerk in the colliery offices without moving from his ordinary post, or at any other point or number of points, by merely running ordinary telegraph wires. The same process may be applied to the different splits of air underground. Hence says "Invention," it is clear that any occurrence in the workings of the mine which to any material extent interferes with the free passage of the air cannot pass undetected, except for a very short space of time, while the district in which the resistance has occurred can also be indicated. Thus, a fall, or falls, of roof occurring in a remote part of an air-way (a contingency, the effect of which, though not perceptible to the physical senses under ordinary circumstances, may be yet capable of producing conditions of great danger by interfering with the free course of the ventilation, and fostering accumulations of gas) would be immediately detected by the person observing, he in his turn promptly reporting the same to the management; a condition of danger would thus be located quickly, which might otherwise have passed undetected for many hours, with possibly disastrous results. The instrument is said to have been tested at some pits in the Rhondda, and proved to be acutely sensitive, indicating lulls and spurts in the air current within a second or two of their occurrence.

Haulage ropes are generally made of steel wire, in Germany mostly of plough steel. According to a paper read by Ellingen, and reported in the "Zeitschrift des Vereins Deutscher Ingenieure," ropes of aloe fibre may still compete with steel, even for deep shafts. The aloe fibre is stronger and more elastic, but less flexible than Manilla hemp; its chief advantage is that it becomes stronger in damp places. The ropes have to be tarred, but in spite of this circumstance, the corresponding lengths of rope which would break by virtue of their own weight, are 12,000 for aloe, and 12,500 for steel. In Belgian mines haulage by means of aloe ropes is quite common; great lengths are made with decreasing thickness. A new style of rope of his own, to which the speaker drew attention, is the simplex rope which Felton and Guillaume manufacture. It is recommended for telfer lines, not for haulage. These wires are tubular. All the wires being visible from outside and pressed against one another, breakages are said to be most unlikely, and faults would at once be discovered. A simplex

rope, six miles in length, has been sent to Java. It is noteworthy that these wires also make good flexible pipes for water supply, etc. The first three wires of this type have been placed, this spring, in a lake near Amsterdam. The laying is very quickly accomplished. The process only is indicated. Over a lead pipe, about 2 in. in diameter, $\frac{1}{6}$ in. thick, an impregnated texture is first applied, and this then wound with $\frac{1}{4}$ in. "fason" wires. An outer layer of cloth, held by galvanised wires, is then added, merely as a protection against rusting. The finished pipe would have a diameter of 82 millimetres, 3'2 3/4 in., weigh 20 kilogrammes per metre, and cost 16 mark—rather a high price. But such pipes may indeed be very convenient for carrying pipe conduits for water, oil, etc., across marshes and rivers.

The Thwaite-Gardner system of utilizing blast-furnace gases is reported now to be receiving much recognition and approval both in England and Scotland, and that many firms are considering the propriety of adopting it. Some installations have already been settled. With a production of, say, 1,300 tons of pig iron per week, requiring, say, 32 cwt. of coal per ton of pig, it is estimated that if one-third of the gases are employed for heating blast, there should be available with the new system some 14,000 horse power, instead of 3,000 horse power with steam boilers, thus leaving a large balance of power in favour of the Thwaite-Gardner system.

Major Walsh, of Brockville, Ont., recently appointed by the Dominion Government, Administrator of the Yukon Territory, whose portrait we have pleasure in reproducing in our illustrated supplement this month, served for many years in the North-West Mounted Police, where he rendered distinguished service in the field. Major Walsh is eminently qualified for the position, and his appointment has given the greatest satisfaction. Since leaving the force Major Walsh has been connected with the coal trade, being associated with the well-known house of Bell, Lewis and Yates. He was also identified with the development of the Souris coal fields, in southern Manitoba.

Notes on Conveying-Belts and Their Use.*

BY THOMAS ROBINS, JR., NEW YORK.

About six years ago the writer had occasion to visit a large magnetic iron-ore concentrating-plant, and then saw for the first time rubber belts being used for conveying purposes. These belts were from 20 inches to 30 inches in width, and some of them were as long as 500 feet between centres. When I spoke of the enormous amount of material they handled with a small expenditure of power, the superintendent assented, but at the same time complained that although he bought the best quality of belts, the abrasion of the ore wore them out very rapidly, causing continually very large bills for repairs and renewals.

On close examination several interesting points were discovered :

1. It was noticed that the thin layer of rubber which covered the belt resisted the abrasion much longer than did a corresponding thickness of the cotton duck which formed the body of the belt ; in fact, the life of the cover represented about one-half the life of the belt, although forming less than one-fifth of the total thickness.

2. Each layer or ply of duck wore out more quickly than the one preceding it, showing that the fibres were cut more easily when under tension, and, of course, the tension on each fibre increased as the number of fibres bearing the tensile strain diminished.

3. The wear was greatest in a line along the centre of the belt. Frequently this part would be so quickly destroyed as to cause the belt to split in two longitudinally, though at the same time the portion nearer the edges was almost as good as new.

Noticing these facts it became obvious that the functions of the cotton duck should be solely to give the belt tensile strength, and that it ought to be so protected by some abrasion-resisting cover that it would not be injured by contact with the material conveyed. It is also evident that this protecting cover ought to be of extra thickness over the centre of the belt, in order to stand the harder work forced upon that part. Being engaged then, as now, in rubber manufacture, it was a simple matter to make a belt with a heavy rubber covering on the carrying side, and thicker in the centre than at the edges.

This reinforced cover renders the resistance to wear equal in all parts of the belt, and although being merely the anticipation of a patch, like the

brass toe-cap on the school-boy's shoe, or the two-ply seat in his trousers, it was, like them, deemed patentable.

The ideal conveying-belt would be like the celebrated "one hoss shay," which disintegrated so evenly and completely when its work was done that there was nothing left to repair or regret.

Wishing to ascertain what particular compound of rubber would make the most durable carrying-surface, I made a lot of small samples, each mixed differently, and exposed them to a very powerful sand-blast, which in its effect approximated the conditions to which the compound would be subjected in actual use, but it was more convenient for a large number of tests, being much quicker. The result of the first series of experiments indicated what grades of gum and what adulterants had better be left out, and also showed something that was very gratifying, namely, that there were certain adulterants which could be used in sufficient quantities to bring the cost down to a reasonable figure. I then made a second set of samples, following in the mixture the formula used in the more successful ones of the first set, but each new one was an attempt to improve upon its prototype. Some of the samples, owing to more intelligent methods in mixing them, proved so durable that that the sand-blast test became too tedious, and a more severe and expeditious one was needed. This was found in exposing a disc of the rubber 6 inches in diameter by $\frac{1}{8}$ of an inch thick to a heavy falling stream of crushed ore. The ore averaged about $\frac{3}{4}$ of an inch in size, and was delivered in a compact and heavy stream from the end of a very fast moving belt. The sample was so fastened to a board as to receive the whole stream of ore, and immediately deflect it. In this way the rubber came in contact with 200 tons of ore per hour, of which each fragment was delivered with considerable force full upon it. At first it was easy to see the comparative loss of weight, after the sample had been exposed to the ore for an hour or two. In the next series results were very apparent after a day's run, but later, as results were developed which I was willing to accept as final, it became necessary to weigh each disc before and after the exposure, and thus learn the percentage of loss. The figures relating to the last set of compounds are as follows :

| Samples. | Weight Before Test. In Grammes. | Weight After Test. | Percentage of Loss. |
|----------|------------------------------------|--------------------|---------------------|
| No. 154 | 103 | 102.7 | .0029 |
| No. 155 | 140 | 138.9 | .0078 |
| No. 156 | 134.7 | 132 | .0164 |
| No. 157 | 116.7 | 113.8 | .0257 |

The test lasted for 12 hours' steady running under the conditions stated above.

Having at last decided upon the proper compound for the carrying surface, I applied it to the belts, and I may say that every belt made since that time, which was in 1892, is in good order to-day. In many cases, too, the belts which they replaced had been completely destroyed in three months' time under exactly similar conditions.

There are four principal methods of supporting conveying belts.

First we will consider the oldest method, in which the belt lies flat upon a straight faced, horizontal pulley, as shown in cross section, Fig 1. On account of the liability of the material to roll off the belt, this form is only suitable under certain conditions. The belt cannot be heavily loaded, and the feed must be so regulated that an even amount may be delivered to the belt at all times. If the material is below $\frac{1}{4}$ -inch in size, the speed may be as high as 300 feet per minute. In carrying larger stuff on flat belts the speed must be lower ; but the most necessary thing is to keep the belt very tight, that the material may not be jarred off in passing over the idler pulleys. This, of course, increases the strain on the bearings, and from that fact, together with their low efficiency compared with systems to be described later, we may consider flat running belts as being out of date.

Fig. 1.

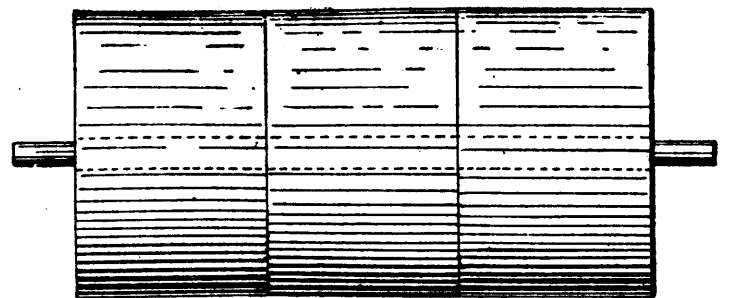

Oldest Method of Supporting Conveying Belts.

The second method (Fig. 2) is somewhat like the first, but with the addition of kirt boards at the sides to increase the capacity of the conveyor.

This method of rigging belt conveyors is in great vogue among brick makers and others who handle clay. It will be easily seen that the material must collect between the skirt boards and the belt, and that, as it hardens, it will cut a strip off each side. The common practice is to start with a wide belt, and move the skirt boards in as fast as these strips are cut off. When the width is so reduced as to render the conveyor totally useless, wheelbarrows are called into play until a new belt can be procured, and the entire process recommenced. This method is so entirely bad, that I refrain from further description. It is only fair to say, however, that the skirt boards fill one useful purpose, as it is the practice of the men shoveling into the belt to rap their shovels against the boards in order to get rid of the sticky clay. A board for this purpose can be applied, however, to a much better form of conveyor, and in such a way that it cannot interfere with the belt. (See Fig. 5.)

The third method is a slight improvement upon the last, in that a trough is made by raising the sides of the belt instead of using boards as described above. The conical pulleys used for this purpose are shown in Fig. 3.

* Paper read before the Am. Inst. of M. E.



N. F. CURRAN,
North Star Mining Co., Fort Steele, B.C.



N. L. DAVENPORT,
Poorman Gold Mine, Nelson, B.C.

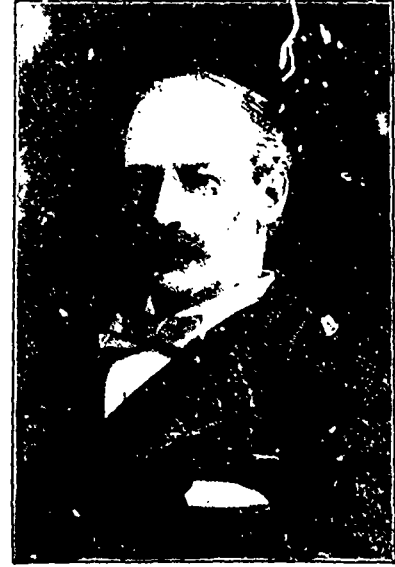

CLARENCE DIMOCK,
Central Rawdon Gold Mine, Windsor, N.S.



J. G. S. HUDSON,
Supt. Roost Colliery, Cape Breton.

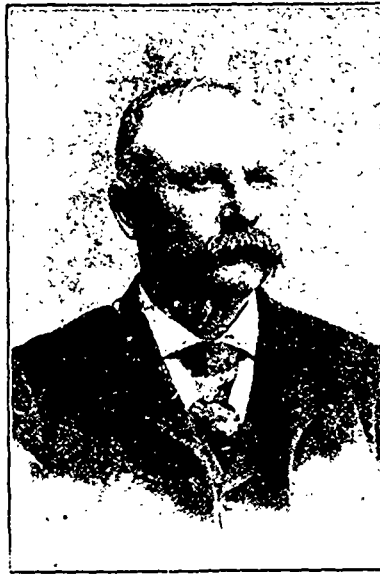

JOHN JOHNSTON,
Supt. Caledonia Colliery, Cape Breton.



JOHN F. CALDWELL,
Sultana Gold Mine, Lake of the Woods, Ont.



MAJOR WALSH, BROCKVILLE,
Appointed Administrator of the Yukon Gold Territory, August, 1897.



E. B. HAYCOCK,
Mining Engineer, Ottawa.



E. J. FIELD, SANDON, B.C.
Wonderful Group Mining Company.



JOHN M. ANDERSON,
Gold Miner, Musquodoboit, N.S.



ANTIMONY MINE AT RAWDON, HANTS CO., N.S., RECENTLY ACQUIRED BY ENGLISH CAPITALISTS.

THE YUKON GOLD COUNTRY.

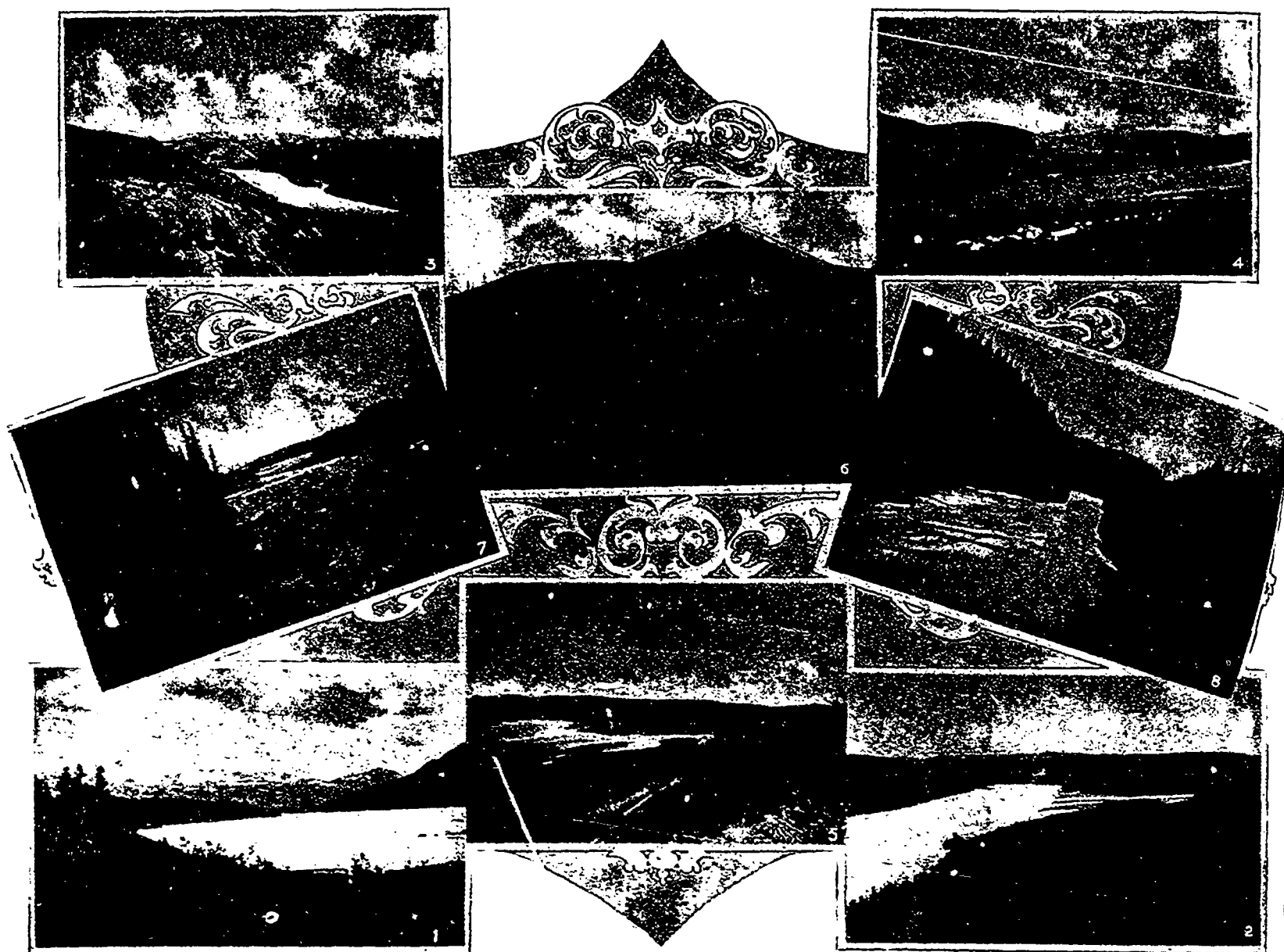

- (1) Lake Lindeman, looking towards Taiya Pass.
- (2) Junction of 40-Mile and Yukon Rivers, showing Fort Constantine, Forty-Mile Town, and Cudahy.
- (3) Yukon River and valley of Coal Creek.
- (4) Junction of 40-Mile and Yukon Rivers (left hand view).
- (5) Junction of 40-Mile and Yukon Rivers (right hand view).
- (6) Ledue's House, Sixty-Mile Post.
- (7) White Horse Rapids.
- (8) Miles Canon.

THE YUKON EXCITEMENT. VIEWS OF THE WHITE PASS.

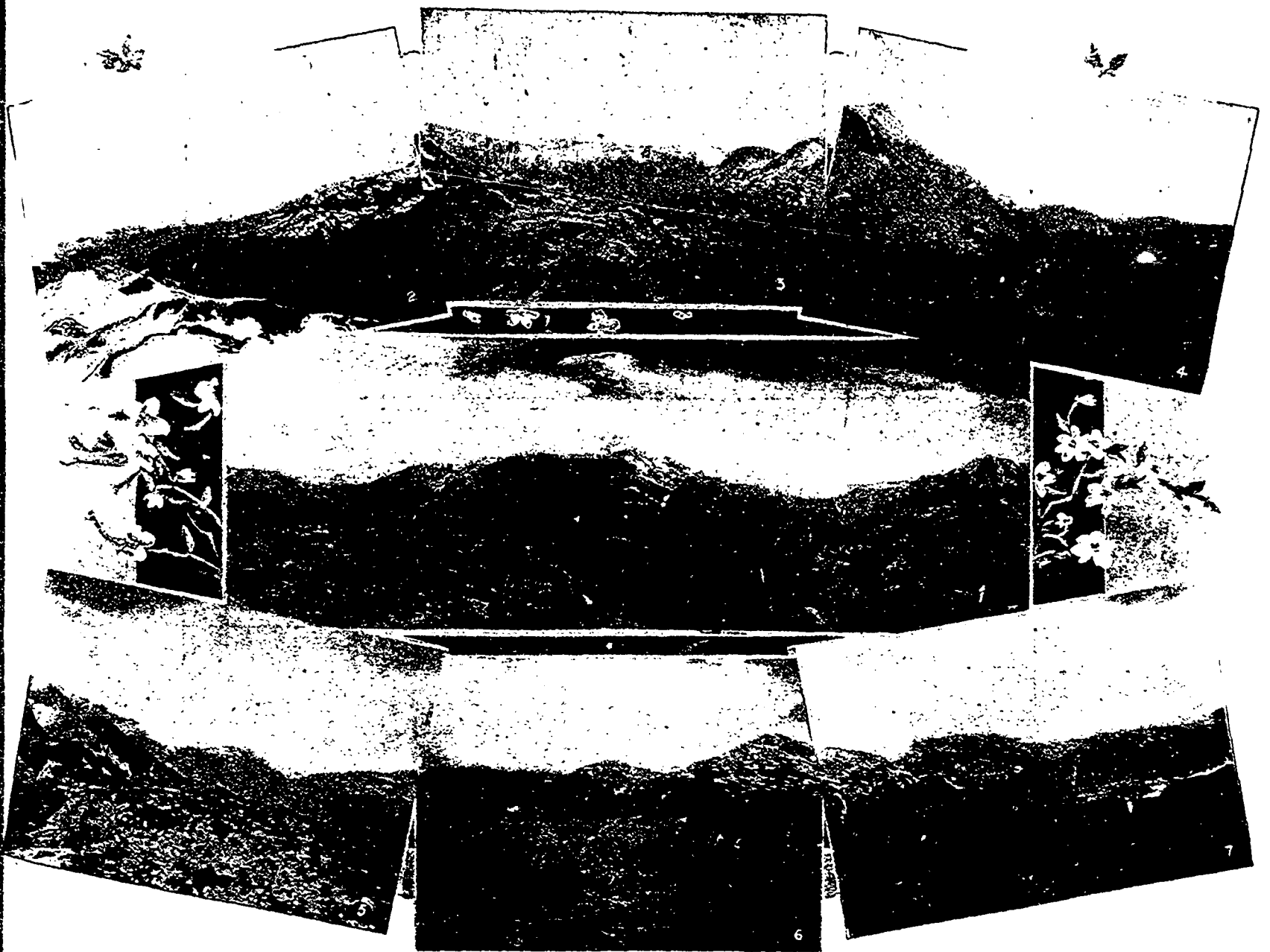

- (1) Looking N.N.E. from Stations 140 and 141. White Pass to left; Upper Shkagway to right.
- (2) Looking S.E. down: Chillkoot Inlet.
- (3) Looking N.E. into and across upper valley of Shkagway.
- (4) Portion of the White Pass.
- (5) Looking up the valley of the Shkagway River from a mountain west of Taiya Inlet.
- (6) Looking west across valley of the Shkagway.
- (7) Looking north from Station 141, showing White Pass Valley.



MODSTOCK GOLD MINING CO.—Main Shaft and Mill, Forest Hill, Stormont District, Nova Scotia.



MODSTOCK GOLD MINING CO.—Fuel Supply at Mine.

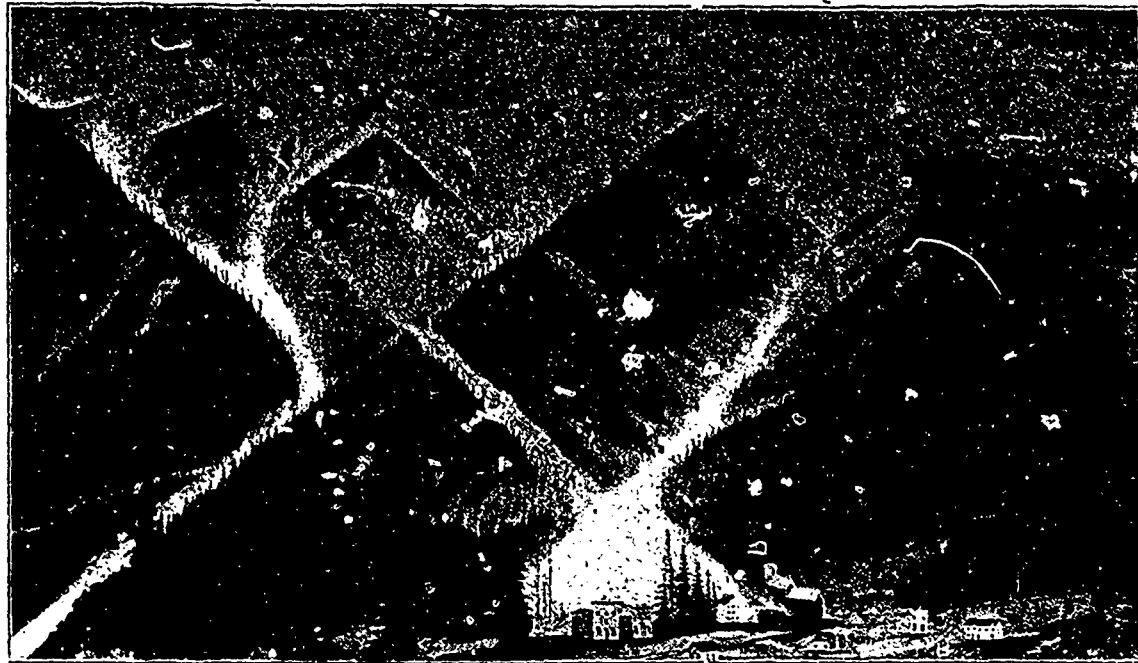

DECO MOUNTAIN AND MINES, SANDON, B.C.

- | | | | | |
|-----------------|----------------|-----------------------|-------------------------|--------------------|
| 1 R. E. Lee. | 4 Last Chance. | 7 No. I. Lead, Reco. | 10 Reco Mines Hotel. | 13 Idaho No. 2. |
| 2 Ajax. | 5 Noble Five. | 8 Omega. | 11 No. III. Lead, Reco. | 14 Chambers Group. |
| 3 American Boy. | 6 Deadman. | 9 No. II. Lead, Reco. | 12 Blue Bird. | 15 Town of Cody. |



GROUP OF MINERS AT MODSFOCK GOLD MINE, FOREST HILL, STORMONT DISTRICT, NOVA SCOTIA.

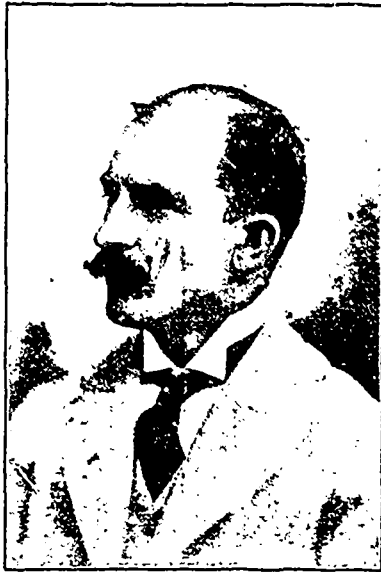

HECTOR MCRAE,
Wellington Silver Mines, Ottawa.



H. C. BAKER, M.E.
Blackburn Mine, Fempton, Que.



GEORGE STUART, M.E.
Truro, N.S.



J. D. MCGREGOR,
New Egerton Gold Mine, Glasgow, N.S.



MILTON L. HERSEY, B.A.Sc.
Montreal.



J. D. COPELAND,
Modstock Gold Mine, Antigonish, N.S.

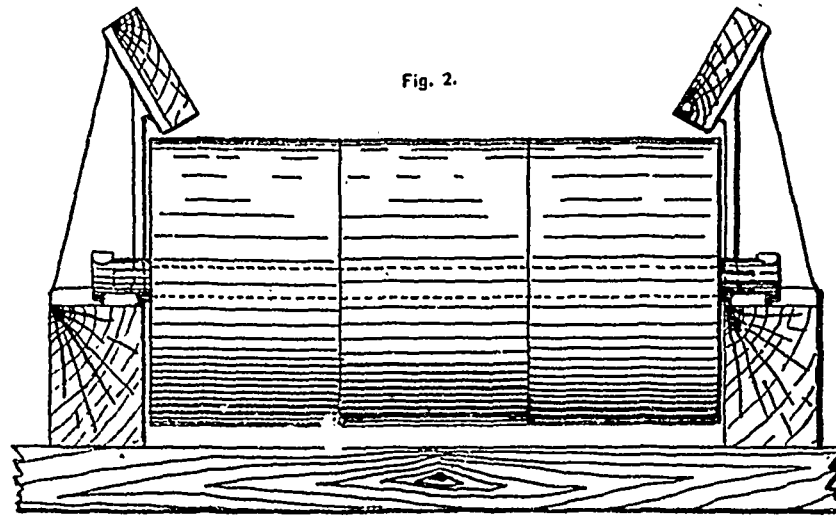

Idler Pulleys, with Skirt Boards added.

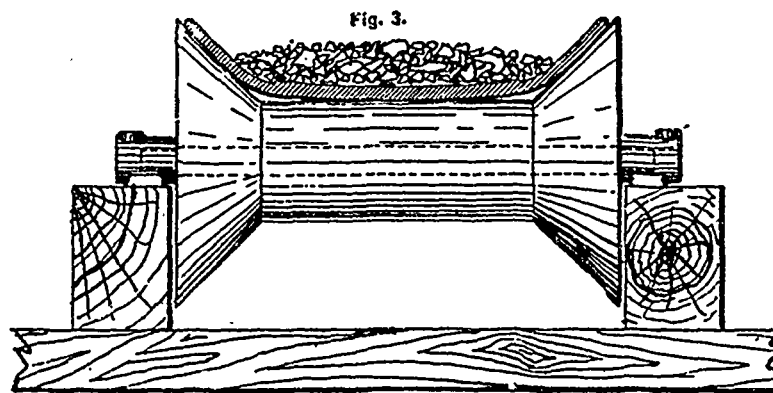

Conical Side Idlers.

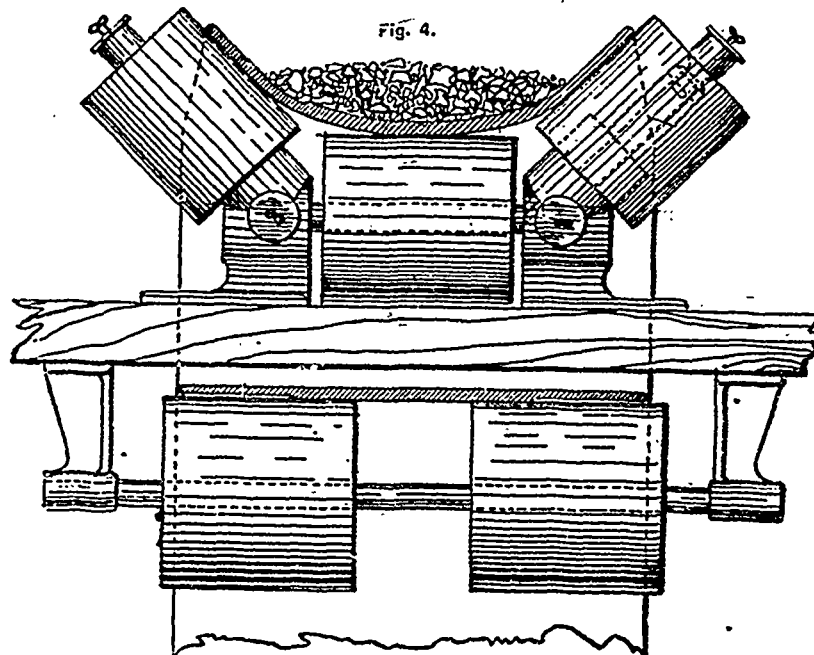

Best Method of Supporting Conveying Belts.

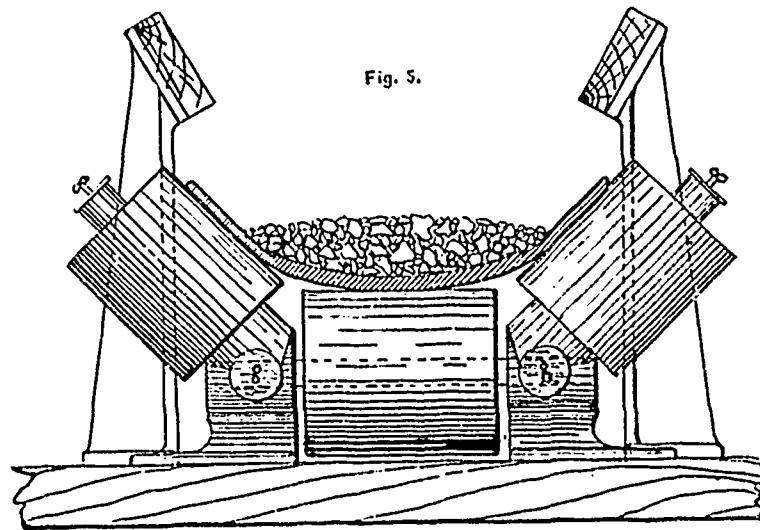

Best Method of Supporting Belts with Skirt Boards.

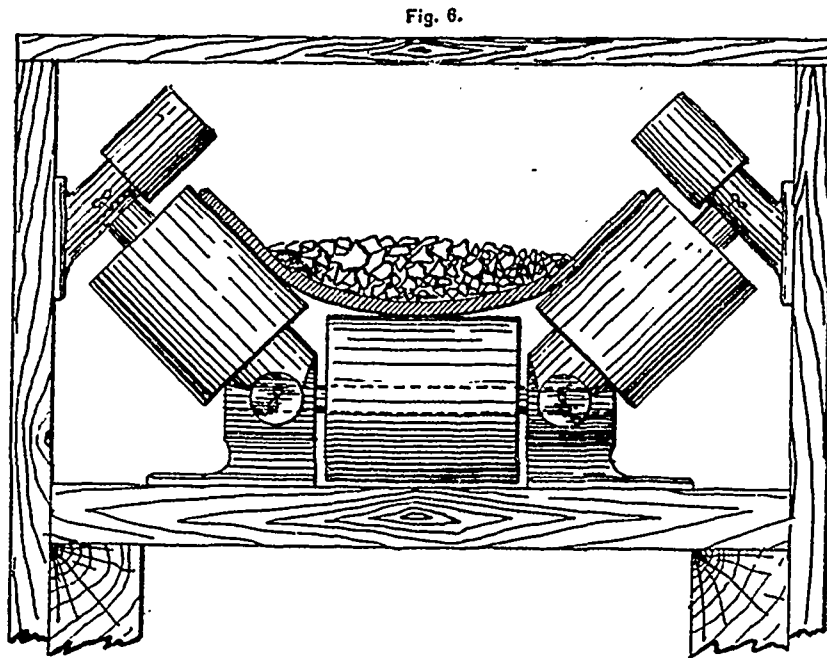

Method of Fig. 4. with Guide Pulleys added.

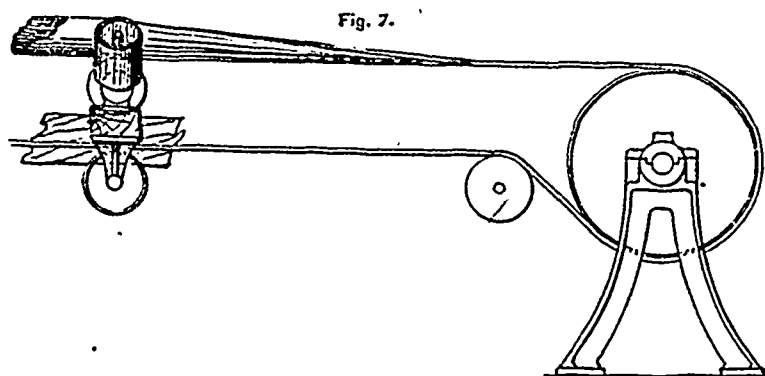

Side View, showing the Proper Position for the First Return Idler, in order to gain large Arc of Contact.

This method has an obvious fault, owing to its bad design. By reason of the difference between the two diameters, the outer edge of the pulley goes twice as fast as the inner edge. This causes a slip which soon wears out the under surface of the belt. For belts not wider than 14 inches this form is not bad, for, with small belts, the weight on the pulleys is light, and the effect of the slipping is consequently less severe.

The fourth, and best form of belt support, is composed of three pulleys, one carrying the middle or bottom of the belt, and one on each side with its axis at an angle of about 45°. The shafts of all three pulleys are held in a pair of combination bearings which can be adjusted to different widths of belt. I never supply any other form of support for belts wider than 14 inches, and when I refer to troughed belts in this paper, it is to be understood that the sides are raised by means of these angle pulleys, one common form of which is shown in Fig. 4.

There has been no mention hitherto of the means of supporting the empty part of the belt on its return. This is done by a single flat pulley of the kind shown in Fig. 1, or with a pair of smaller pulleys with an interval between them, as shown in the lower part of Fig. 4.

It is sometimes possible to save money in constructing a long conveyor by combining the first and last methods of belt support referred to. If the belt were run flat the whole distance, it would need to be so wide that the extra cost of the belt would be about equal to the money saved in using the cheaper flat form of pulley: but by placing a set of troughing pulleys between every fourth and fifth set of flat pulleys, or at such other interval as may be found advisable, the load is so centred on the belt at each of these points that it has no time to overflow before it is again centred between the next pair. In this way the use of a very wide belt is unnecessary, but the conditions are not always favorable to this plan.

On some conveyors, it is often advisable to have at intervals a pair of idlers, running on a vertical axis, or inclined inward, so as to make a right angle with the edge of the belt. These will serve to keep the belt straight on the pulleys if there is any tendency to run toward one side. See Fig. 6.

The large pulleys at the end of the belt should be slightly crowned on the face, and the pulleys should not be less than 4 inches wider than the belt. The driving pulley ought never to be less than 30 inches in diameter, and in the case of long wide belts 48 inches is advisable, as it allows the first return pulleys to be so placed as to give the belt a very large arc of contact on the driving pulley. (See Fig. 7.)

Whenever it is possible, it is better to have the driving pulley at the delivering end of the belt; but, if it must be at the receiving end, a triple set of pulleys connected by gears can be easily arranged, which renders slipping impossible with the longest and heaviest loads. I believe that this scheme was first used by Mr. S. H. Edwards, Superintendent of the Magnetic Iron-Ore Co., at Benson Mines, New York. (See Fig. 8.)

The proper distance between the sets of idler pulleys is an important factor in the economical running of the belt, as will be referred to later. I believe that the troughing pulleys should be from 4 to 6 feet apart, according to the weight of the load, and that for the return belt there should be pulleys placed under every alternate set of troughing pulleys, which would make the lower pulleys from 8 to 12 feet apart.

To me, one of the most wonderful things in connection with this subject is the exceedingly small amount of powder required to move enormous quantities of material. The power required, in one case, to run a conveyor, which carries 1,000 tons per day a distance of 180 feet, and elevates it 40 feet while doing so, is all transmitted by a torn and frayed little 5-inch belt, which takes its power from a pulley on the shaft, and transmits it to a pulley alongside the head pulley of the belt. The power is here divided, part of it going over a sprocket-chain to help drive a large dumping-apparatus. Yet the entire amount of power employed for both purposes does not exceed four horse-power.

I would like very much to give some rule for determining the exact number of horse-power required for conveying-belts running under different conditions, but I find it impossible, owing to the number of variable quantities which make up the load. One of the most important of these points is based upon the distance between the sets of troughing pulleys. If they are too far apart the belt sags down between, which materially increases the load. If, on the other hand, the idlers are too near together, the extra number of bearings makes another sort of resistance to be overcome. No general rule can therefore be made by which the required horse-power can be accurately determined.

It is a simple matter to determine the necessary belt-width and speed to perform certain duty when the weight per cubic foot of the material is known. If the belt is troughed it is safe to estimate that the load itself will cover one-half of the belt's total width, and that the depth in the centre will be one-quarter of its own width. The area in inches of a cross-section of the load (which we may consider an inverted triangle) will when multiplied by 12, give the number of cubic inches of material borne by the belt on each running foot of its surface. Multiply this result by some estimated speed to get the quantity in cubic inches that the belt will deliver per minute, and then reduce this to the number of feet, yards, pounds or tons delivered per hour, or to other convenient terms. (See Fig. 9.)

For example: To find the number of tons of material weighing 1000 pounds per cubic foot that can be delivered by a 24-inch belt running 250 feet per minute:

As the belt is 24 inches wide we may safely consider the load as being a triangle standing on its apex, and having a base 12 inches wide and a height of 3 inches. Therefore, the area of its cross-section will be 18 inches, and there will be 18 x 12 = 216 cubic inches on each foot of the belt. As the speed is 250 feet per minute, there will be delivered from the end of the belt 250 times 216 cubic inches, or 54,000 cubic inches per minute. This is equal to 31 1/4 cubic feet per minute, or 1875 cubic feet per hour, weighing 187,500 pounds, or about 93 tons per hour.

To save some of the steps referred to above, the following formula may be used. If we let A = width of belt, then $\frac{3A^2}{8} =$ number of cubic inches carried on each running foot of the belt. If a belt is run flat it will carry about one-third as much, or $\frac{A^2}{8}$. It is well to remember that when the width

of a belt is doubled it will carry four times as much material, and when it is tripled it will carry nine times as much.

The following table will be found of service in determining the capacity of conveyer-belts.

In regard to this table I wish to say that the results shown are based upon a continuous and even delivery of fine material to the belt. As this is often unattainable in practice, it is well to prepare for uneven and large pieces and for irregular feed, by allowing a margin in either belt-width or speed, the two factors which cover the capacity of the belt. The widths of belting in most common use are 22, 24 and 26 inches, and the average speed is about 300 feet per minute. I am inclined to favor higher speeds, especially

TABLE SHOWING THE NUMBER OF CUBIC FEET OF MATERIAL DELIVERED IN AN HOUR BY DIFFERENT WIDTHS OF TROUGHING CONVEYING-BELTS TRAVELLING AT VARIOUS SPEEDS.

| Width of Belt in In. | Speed per Minute in Feet is Shown in the Line next below this. | | | | | | | | | | | | | | | |
|----------------------|--|--------|--------|--------|--------|--------|--------|--------|--------|--------|---------|---------|---------|---------|---------|--|
| | 100 | 150 | 200 | 250 | 300 | 350 | 400 | 450 | 500 | 550 | 600 | 650 | 700 | 750 | | |
| 12 | 187.5 | 281.2 | 375.0 | 468.7 | 562.5 | 656.2 | 750.0 | 843.7 | 937.5 | 1031.2 | 1125.0 | 1218.7 | 1312.5 | 1406.2 | 1500.0 | |
| 14 | 255.2 | 382.8 | 510.4 | 638.0 | 765.6 | 893.2 | 1020.8 | 1148.4 | 1276.0 | 1403.6 | 1531.2 | 1658.8 | 1786.4 | 1914.0 | 2041.6 | |
| 16 | 333.3 | 500.0 | 666.6 | 833.3 | 1000.0 | 1166.6 | 1333.2 | 1500.0 | 1666.6 | 1833.2 | 2000.0 | 2166.6 | 2333.2 | 2500.0 | 2666.6 | |
| 18 | 412.8 | 619.2 | 825.6 | 1032.0 | 1238.4 | 1444.8 | 1651.2 | 1857.6 | 2064.0 | 2270.4 | 2476.8 | 2683.2 | 2889.6 | 3096.0 | 3302.4 | |
| 20 | 520.8 | 781.2 | 1041.6 | 1302.0 | 1562.4 | 1822.8 | 2083.2 | 2343.6 | 2604.0 | 2864.4 | 3124.8 | 3385.2 | 3645.6 | 3906.0 | 4166.4 | |
| 22 | 630.2 | 945.3 | 1260.4 | 1575.5 | 1890.6 | 2205.7 | 2520.8 | 2835.9 | 3151.0 | 3466.1 | 3781.2 | 4096.3 | 4411.4 | 4726.5 | 5041.6 | |
| 24 | 750.0 | 1125.0 | 1500.0 | 1875.0 | 2250.0 | 2625.0 | 3000.0 | 3375.0 | 3750.0 | 4125.0 | 4500.0 | 4875.0 | 5250.0 | 5625.0 | 6000.0 | |
| 26 | 880.2 | 1320.3 | 1760.4 | 2200.5 | 2640.6 | 3080.7 | 3520.8 | 3960.9 | 4401.0 | 4841.1 | 5281.2 | 5721.3 | 6161.4 | 6601.5 | 7041.6 | |
| 28 | 1020.0 | 1530.0 | 2040.0 | 2550.0 | 3060.0 | 3570.0 | 4080.0 | 4590.0 | 5100.0 | 5610.0 | 6120.0 | 6630.0 | 7140.0 | 7650.0 | 8160.0 | |
| 30 | 1170.1 | 1755.0 | 2340.2 | 2925.3 | 3510.3 | 4095.3 | 4680.4 | 5265.4 | 5850.5 | 6435.5 | 7020.6 | 7605.6 | 8190.7 | 8775.7 | 9360.8 | |
| 32 | 1333.3 | 2000.0 | 2666.6 | 3333.3 | 4000.0 | 4666.6 | 5333.2 | 6000.0 | 6666.6 | 7333.2 | 8000.0 | 8666.6 | 9333.2 | 10000.0 | 10666.6 | |
| 34 | 1505.2 | 2257.8 | 3010.4 | 3763.0 | 4515.6 | 5268.2 | 6020.8 | 6773.4 | 7526.0 | 8278.6 | 9031.2 | 9783.8 | 10536.4 | 11289.0 | 12041.6 | |
| 36 | 1687.5 | 2531.2 | 3375.0 | 4218.7 | 5062.5 | 5906.2 | 6750.0 | 7593.7 | 8437.5 | 9281.2 | 10125.0 | 10968.7 | 11812.5 | 12656.2 | 13500.0 | |

for elevating at an angle, as it requires less power to lift a small sized load at a high speed than the same amount of stuff per hour in a larger sized load at a low speed. A good speed for level work is 450 feet per minute; at an angle 650 feet is not at all too fast; and I have seen belts working smoothly at 900 feet per minute, and at an angle of 27 degrees. Such speed as this, however, is hard on both the belt and idlers, and I do not recommend it.

Having decided upon the proper width of belting for the duty to be performed, the next points to be settled are the proper thicknesses for the belt and for its protecting cover.

The following table shows the suitable number of plies for different widths of conveyer-belts:

| |
|--|
| Belts 20 inches wide and less should be 4-ply. |
| " 22 and 24 " " " 5 " " |
| " 26 and 28 " " " 6 " " |
| " 30 to 36 " " " 8 " " |

The thickness of the rubber cover should be based upon the character of the stuff to be carried. For hard material weighing over 50 pounds per cubic foot, the cover should not be less than 1/4 inch in thickness. With the patent reinforced cover referred to above, it is possible to have this thickness at the centre where it is needed, allowing it to taper off to 1/8 inch or 1/4 inch at the sides where the work is lighter. This, of course, makes the cost lower than if the same thickness of cover extended the whole width of the belt. The belt with the reinforced cover referred to is shown in Fig. 10, A. There is now an improved form of this belt which combines the advantages of this thickened cover with stiffened edges which give it such firmness at that part that a mere touch against the steering idlers serves to

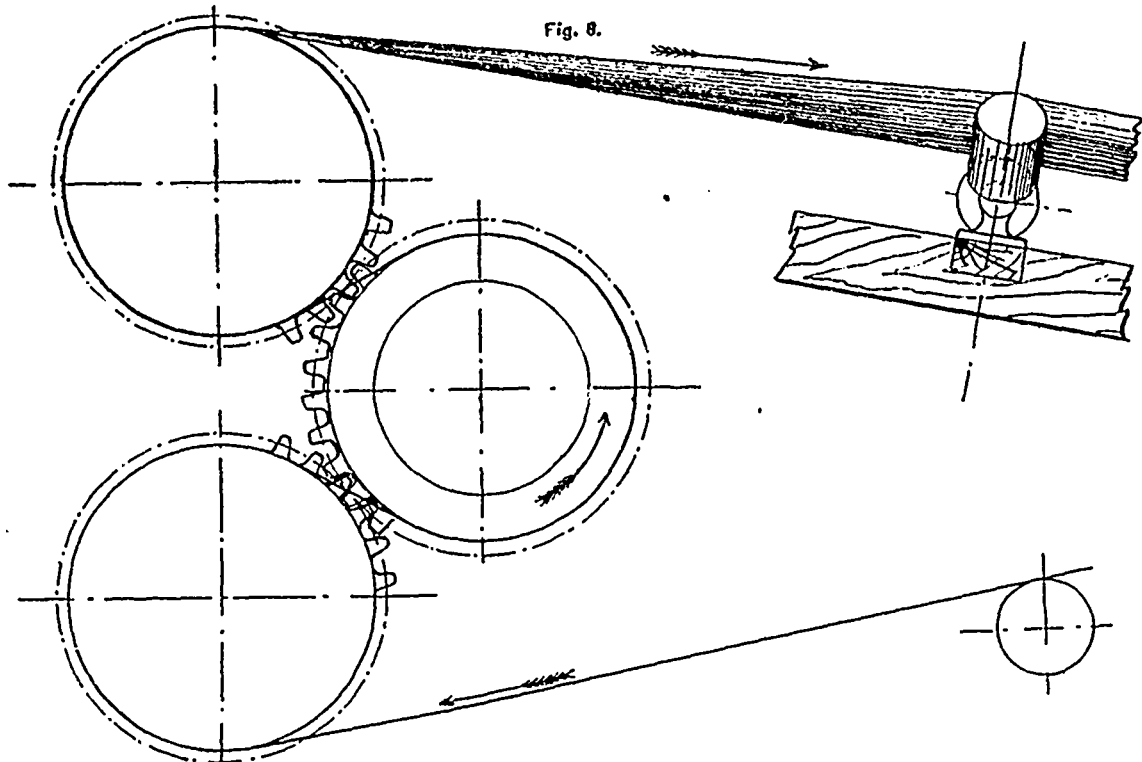

Method of Driving Long Conveyors from the Receiving End.

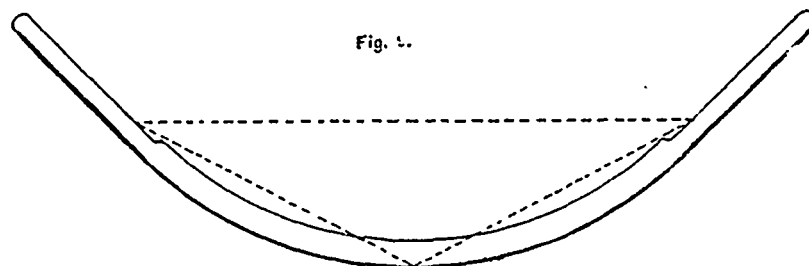
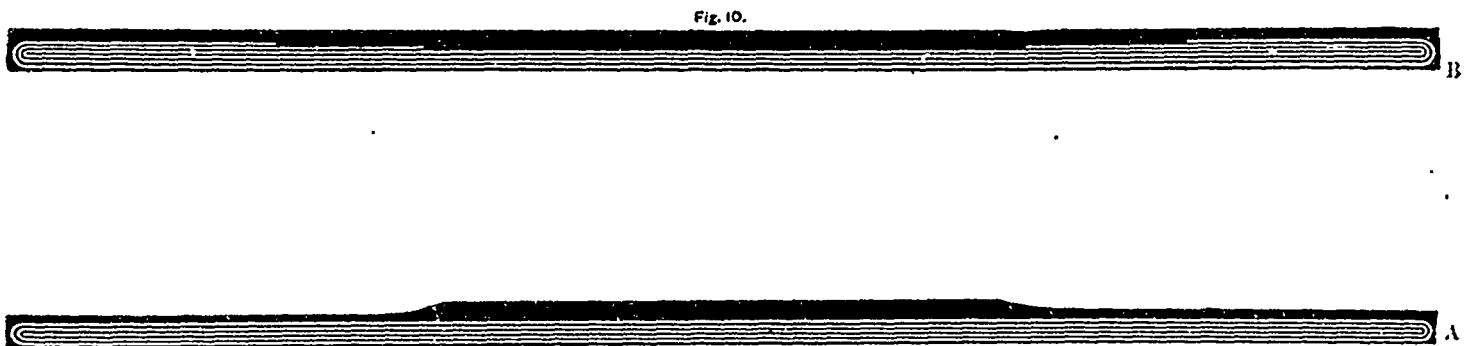
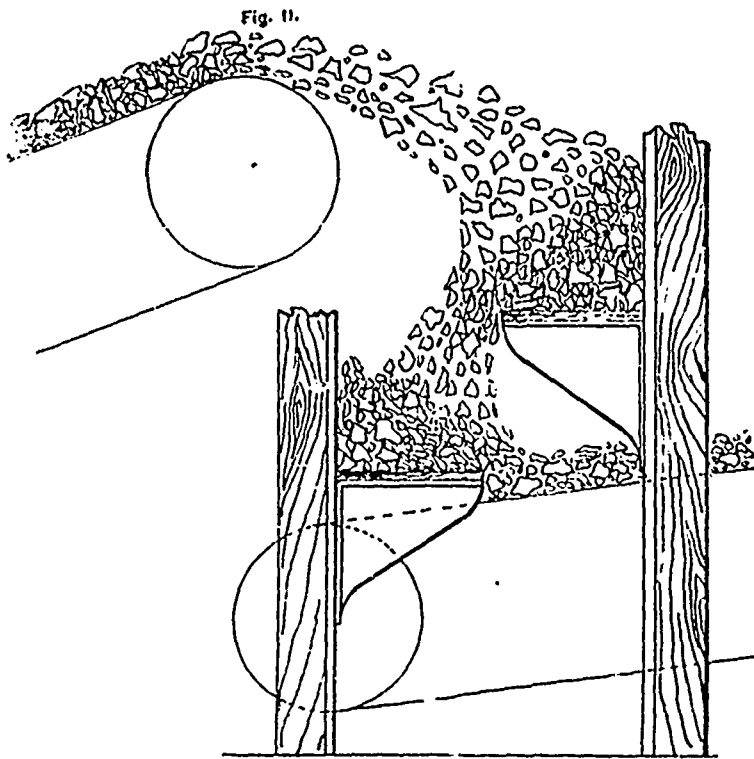

Diagram showing Method of Calculating Working Load.



Cross Sections showing Structure of Patent Conveying Belts.



Section showing Delivery of Coarse Material from one Belt to another.

FIG. 12.

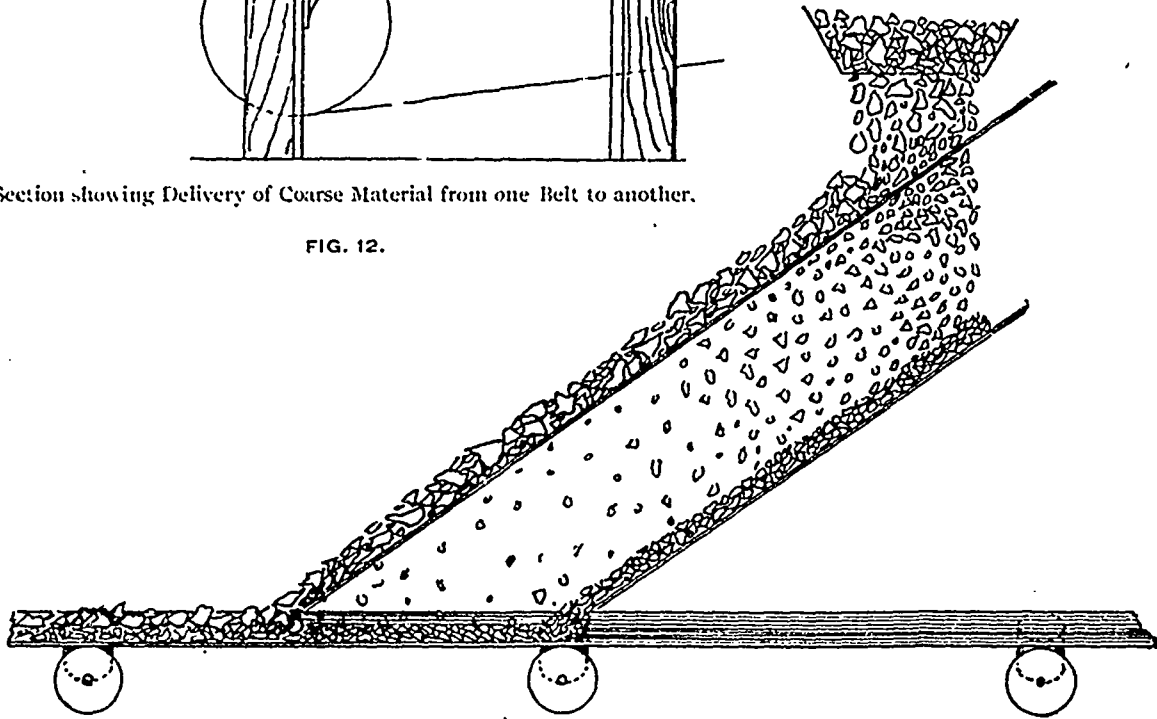

Combination of Grizzly and Belt.

Fig. 13.

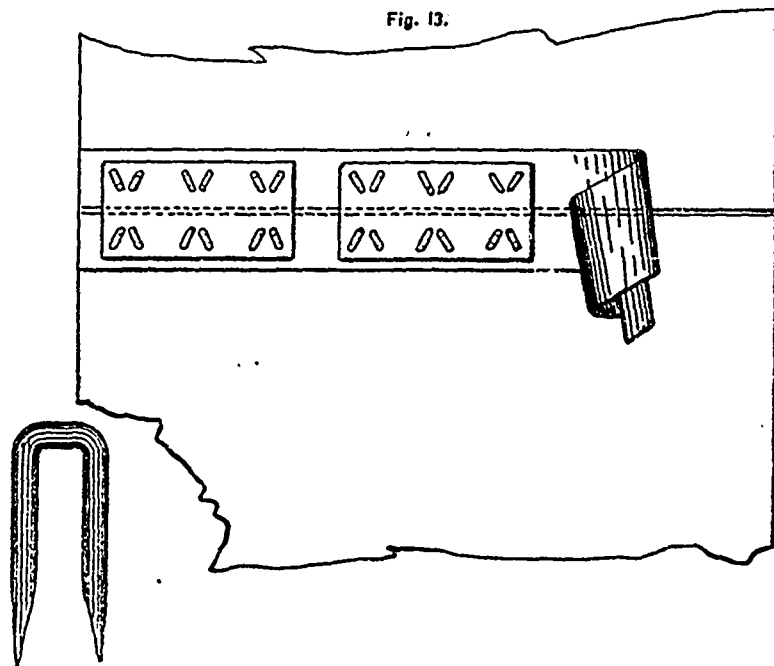

Method of Joining the Ends of Conveying Belts.

keep it running true. This stiffening is done by running two or three plies of duck a part of the way in from the edges, giving all the advantages of a heavier belt, but at a lower cost. This form will also be patented. (See Fig. 10, B.)

At the point where a belt receives its load it gets as much wear as it meets with in all the rest of its journey. A few points should be borne in mind in connection with this part of the conveyer. The material should not be allowed to drop vertically upon the belt, but should instead be so guided by an interposed chute as to strike the belt with as nearly as possible the same speed, and, of course, in the same direction as that of the belt itself. This is much the same principle as that which causes a man who wishes to board a fast moving car to run along a few feet before jumping upon the step, except that in the former case it is the wear and tear upon the vehicle or belt which is avoided instead of injury to the passenger.

If ore or rock is carried, there is bound to be wear wherever it touches. It is well, therefore, if it has to fall any distance, to let its force be broken by striking first against an accumulated pile of itself, and then roll off onto a chute, whence it may slide quietly upon the belt, and not move until it reaches the end of its journey. See Fig. 11, which shows the device in use at the N. J. and Penn. Concentrating Works, Edison, New Jersey.

The chute should be made of cast-iron with sides, and should be so wide that the ore or other metal cannot get jammed, as it is very apt to do. The objection to a wooden chute is, that the broken stone or ore does not slide properly upon it, but runs down in a succession of jumps, that are apt as not to carry it over the side of the chute or off the belt.

A device is shown in Fig. 12 for loading a belt under a crusher, from which falls both coarse and fine stuff. The line A represents a grizzly or screen of iron bars, which allows nothing larger than one inch to go through. The small stuff slides down the chute, and forms a bed on the belt to protect it from the impact of the heavier pieces.

There are many ways of joining the ends of carrying-belts, the most common being by the use of metal belt hooks, consisting of a set of teeth cast together with a metal back. These have to be destroyed if the belt needs taking up, and a better plan is shown herewith in Fig. 13. The thin steel plates are laid upon a strip of thin leather or canvas, which covers the opening in the belt and thus prevent leakage. Staples are driven through the holes in the plate and clinched. In breaking the joint the staples are easily cut with a cold chisel, but the plates themselves can be used an indefinite number of times. They are the invention of Mr. S. H. Edwards.

The simplest method of lubricating the bearings is by means of compression grease cups, which are dust proof and very economical. They are screwed into the ends of hollow shafts, and a man without stopping can give the handles a turn as he walks along the belt, and this only has to be done once a day at most. Grease costing about four cents a pound is generally used.

Some of the purposes for which conveying-belts are used are the carrying of trap-rock and limestone in stone-crushing plants, charcoal and ashes in sugar refineries, ore in concentrating-plants and mines, earth and stone in large excavations, blocks and logs of wood in pulp-mills, clay in brick-yards, coal in breakers, yards, large power-plants and culm-piles, tobacco in process of manufacture, customers' packages in large retail stores, grain in elevators and flour-mills, boxed goods in coffee-mills, phosphate-ore in the southern mines, and chemical fertilizer in plants all over the country. These are only a part of their uses, but the list of other purposes for which, though not employed, they are equally suited, and must some day be applied, would be a very much longer one.

Belts generally cost less to instal than any link-belt or other metal conveyer; and the cost of maintenance is so much less that there is simply no comparison between them. In addition to this they run noiselessly, instead of making a perpetual and deafening racket, and no owner's ears can become oblivious to a banging and crashing, of which every vibration means wear and depreciation, as well as loss of power.

You may say, "If this belt method of conveying is all that this man claims, why haven't we heard more about it? Why isn't it used more widely?" My answer is this: The various systems of sprocket-chain, metal pan, trough and screw conveyers, and the overhead cable systems, have all been owned by manufacturing concerns, who make them known by advertising, undertake their construction and installation, and guarantee them. As to conveying-belts, no fundamental patent on the principle could be secured: and because a belt-conveyer is composed of two parts which are about equal in value, and the products or entirely separate kinds of manufacture (I refer to first, the iron pulleys and other supporting parts, and second, to the belt itself), no iron man felt like pushing the sale of a conveyer when he knew that some rubber manufacturer would share equally in the profits, and the rubber man would doubtless have felt the same if, with his less extensive knowledge of machinery, the thought ever occurred to him at all. And so, between them, the belt-conveyer has been neglected, except where its merit compelled the recognition of a few wide-awake and self-reliant engineers. It has been the property of no one. Nobody's living depended upon its exploitation. It was to the interest of no one to stand sponsor for it; to develop, push it and perfect it. There are no data published about it, and each man who uses it to-day is practically the inventor of his own apparatus, which he has brought to its present state only after an expensive and vexatious experience. If an engineer to-day has a conveying problem to solve, and the thought of a belt occurs to him, immediately after come the questions: What kind of a belt? What width? How should it be run? On what? At what speed? Where can I find out? Being unable to answer any of these questions, and not caring to try experiments, his natural inclination is to state his needs to the well-known manufacturers of conveying apparatus, and make a contract with one of them, thereby shifting the responsibility as soon as possible. The load of responsibility is apparently charged for along with the apparatus, but even the high price of the latter contains no suggestion of the great and continual expense incurred in running it and keeping it in order.

I do not wish to appear as condemning universally the use of all metal conveyers, for there are indeed some conditions for which they are better suited than are belt-conveyers. I may mention, for instance, places where the point of delivery must be constantly and quickly changed. With iron conveyers this is accomplished by the removal of a section of the iron trough,

while a belt requires a movable frame-work containing two pulleys. Its dumping apparatus can be moved to any point in the belt's length, but is neither as cheap in construction nor as quick in operation as the plan adopted with metal conveyers.

Nor do I condemn the great ingenuity which has made possible even the *poor performance*, by metal conveyers, of duties for which by their very nature they are unfitted. That is business. I only want to show that there are many places where other conveyers are now used for which belts could be substituted with economy.

The other day a man pointed to what he called a "real conveyer," which was dragging and scraping its load along (and apparently protesting against its own design and unfitness for the task), and observed: "Oh, this does the work cheap enough." It may be cheap, compared with manual labor; but it seems to me that with the competition of the present day nothing is cheap enough if there is anything cheaper. The object of these notes and sketches is to facilitate the use of belt-conveyers. I have gone into details, in order that any one who wishes to do so may construct a conveyer suitable for his needs. If there are any points which need to be simplified I shall be very glad to explain them to any member of the Institute who will write to my New York address, 71 Lexington Avenue.

The Use of the Tremain Steam Stamp with Amalgamation.

By EDWIN A. SPERRY, GUNNISON, COLO.

The use of stamp mills in the crushing of ore for the purpose of amalgamation has been very limited, and little has been written on the subject. As the writer has been operating a mill of this kind during the past year, it is possible that he may be able to present a few points in regard to mill practice in this line which will be of interest.

The mill herein referred to contains two Tremain steam stamps, a more detailed description of which will be given below. A bond and lease had been taken on a property on Cross Mountain, Gunnison County, Colo., and the parties operating wished to prospect it thoroughly and did not wish to ship out the ore, owing to high freight rates. They looked around to find some mill that would answer the purpose and not be too expensive. The steam stamp in question was finally decided on, and the writer was employed to erect and operate it.

The economy of construction was demonstrated at the outset. The stamps were dropping within ten days from the time that the machinery was unloaded on the ground. A large portion of this period was consumed in waiting for supplies and fittings which should have been on the ground at the same time with the machinery.

Ore—The ore to be treated was a mixture of white, porous quartz, with the decomposed and undecomposed oxides of iron and manganese in varying proportions, from the pure white quartz to solid pieces of the oxides. It appeared to be the product of replacement in a soft dolomite at or near the line of contact with a dike of porphyry. On careful examination with the aid of a microscope it was found that the gold was in the form of an extremely thin film over the surfaces of the quartz, making only a bronzy-yellow coating, quite readily distinguished from the film of iron oxide, which was also present.

Mill—The mill was constructed on the usual plan, with the ore bin above and against the hill, which was cut into for the main building. The bin was of about 20 tons capacity. No rock breakers were used, but the larger pieces of ore were broken by hand to a size that would pass through a 3-inch ring. The ore passed into a Challenge ore feeder, from which it was fed into the mortar.

For the benefit of those not familiar with the steam stamp under discussion, although some may be, a description will be given so far as to make clear any reference made hereafter to any part.

The sections of the stamp shown in Fig. 1 will give some idea of its mechanical construction.

The mortar is 12 by 20 inches in size at the inside of the lip of the discharge, and 14 by 24 inches at the outer edge of the lip. Screens are placed on three sides, the front and the two ends, giving 38.4 square inches of screen surface. The depth from the discharge to the bottom of the mortar, including the recess made to receive the die, is 7 inches. The die, being 5 inches high leaves only 2 inches issue for the pulp. This was increased to 6 inches by the addition of a 4-inch "chuck-block," carrying a copper plate on the inside. This reduced the screen area to 256 square inches, but did not materially decrease the capacity.

The stamp comprises the piston, stem and stamp head, and when newly shod, weighs 300 pounds. The steam lifts the stamp by a 6-inch piston head, the lower area of which is reduced by the 4-inch stem, which extends downward from it, leaving, as a lifting area an annular surface 1 inch wide at the outer edge of the head.

When the piston is raised to a certain point, connection is made between the two ends of the cylinder. The upper surface of the piston head being greater, the stamp is forced down with a force proportionate to the surfaces, together with its weight, giving a blow of about the same force as that of a 1000-pound stamp. The length of the drop varies from 5 to 8 inches, according to the amount of wear on the shoe and die. Provision is made for the operating of the automatic feeder, by cutting a recess in and around the stem near the steam chest, into which a collar is bolted which actuates the feeder arm. Reference will be made to this later on. The shoes are cast similar in form to the gravity stamp head, with the exception of the recess in the lower end, to receive the shank of the shoe. They are fitted to the stem by placing short feathers of sheet brass around the sides of the hole in the upper end of the shoe, placing it on the die in the battery, in its proper position, and allowing the stem to drop into it. The entire stamp is raised with a bar and allowed to drop several times until secured. Steam is turned on slowly and the stem driven to place by a few blows, when it is ready for regular work. There is a system of ratchets and pawls which revolve the

* Transactions of the American Institute of Mining Engineers.

stamp on the upward stroke, leaving it to fall in a direct line. There is, on average, one complete revolution to about 15 strokes. The shoes and dies wear very evenly and smoothly, and with the ore in question wore about 1/2 inch each per 100 tons crushed. Thirty-mesh screens were used at first, but on experimenting, it was decided to use 20-mesh instead. This gave a product of the following de-

little amalgamation is accomplished in the mortar; fully 95 per cent. of the amalgam recovered comes from the outside plates. Of these there are 8, of which 3 are attached to the mortar, one just below each screen. These are cleaned up but once a week. There are 5 apron plates, 4 1/2 feet wide, and 16 feet in aggregate length.

The first is 8 feet long; and the second, third, fourth and fifth are each 2 feet long, and are arranged as shown in Fig. 2. This arrangement, in this case, is very effective, as the mercury in the two wells can be kept active by the addition of sodium amalgam, preventing in a large degree the loss of quicksilver "sickened" by the oxides in the ore. By this method the loss of mercury was reduced half, or from 2 to 1 ounces per ton of ore treated.

Owing to the fact that the proportion of heavy oxides was very great, sometimes amounting to 60 or 70 per cent., it was quite impossible to use the common forms of traps to recover mercury, and two forms were finally adopted which proved quite satisfactory. One was in the form of a "clean-up pan," which was arranged to be continuous in feed and discharge, and constantly stirred. This was used outside of the mill. The other was of the form shown in Fig. 3.

This was effective and convenient, saving considerable "floured" and "sickened" mercury. It is a modified form of the *Spitzlutte*, having a copper plate on the slope on which the pulp falls. In the figure A is an inlet-pipe to supply water for the upward current at B. C is a board set in across the trap to prevent surface currents. D is a V-shaped trough across the bottom of the trap to receive the mercury and the heaviest sands. E is an opening into the trough at its point, into which is sewed a short nipple, covered with a cap. When it is necessary to clean the trough, the cap is taken off from the nipple and a piece of pipe which fits closely inside the nipple is inserted and worked in and out, cleaning the entire length of trough. The copper plate on the sloping bottom of the trap worked well, but it was necessary to clean it often, owing to filiming by the oxide.

Fig. 1

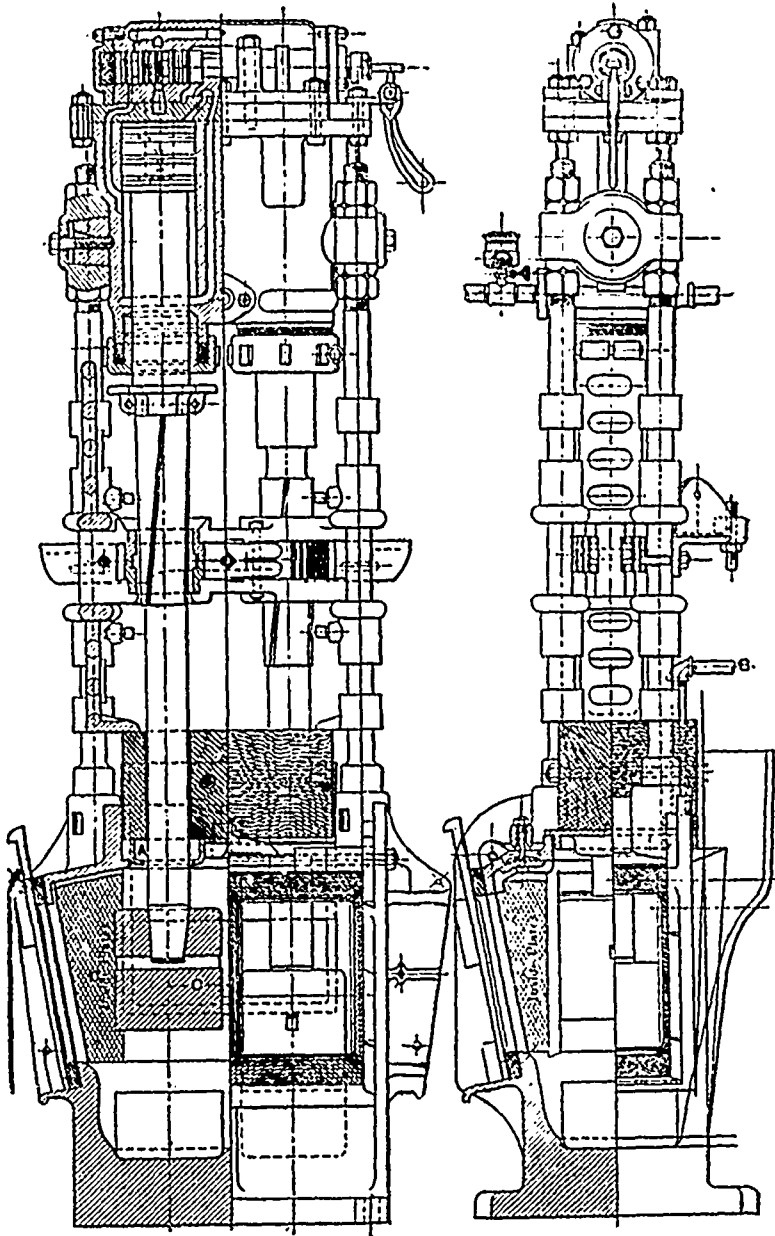

Tremain Steam Stamp, Vertical Sections

scription, as to proportions of size and values. The crushing is evidently fine enough, and could be coarser but for the fact that the tailings were to be subjected to a subsequent treatment, which required the size to be no coarser.

TABLE I—RESULTS OF SCREENING.

| Size. | Per Cent. | Value per Ton. | | Contents, per Cent. | |
|--------------------|-----------|----------------|---------|---------------------|---------|
| | | Gold. | Silver. | Gold. | Silver. |
| On 40 mesh..... | 28.5 | \$14.00 | \$1.12 | 18.07 | 26.7 |
| On 60 mesh..... | 4.0 | 13.00 | 0.72 | 2.36 | 2.4 |
| On 80 mesh..... | 10.5 | 14.00 | 1.00 | 6.65 | 8.8 |
| On 100 mesh..... | 8.5 | 16.00 | 0.92 | 6.16 | 6.5 |
| Through 100 mesh.. | 48.5 | 30.40 | 1.37 | 66.76 | 55.6 |
| | 100.0 | | | 100.0 | 100.0 |

The mortar, as originally designed, was intended to have four amalgamated copper plates inside. These were to be placed in the corners and were very small. The splash was so great that they scoured badly. They were covered with wire screen cloth, and the results were greatly improved, but they were finally abandoned entirely, and the copper plates on the "chuck-blocks" were substituted, but these were not satisfactory. Very

Fig. 2.

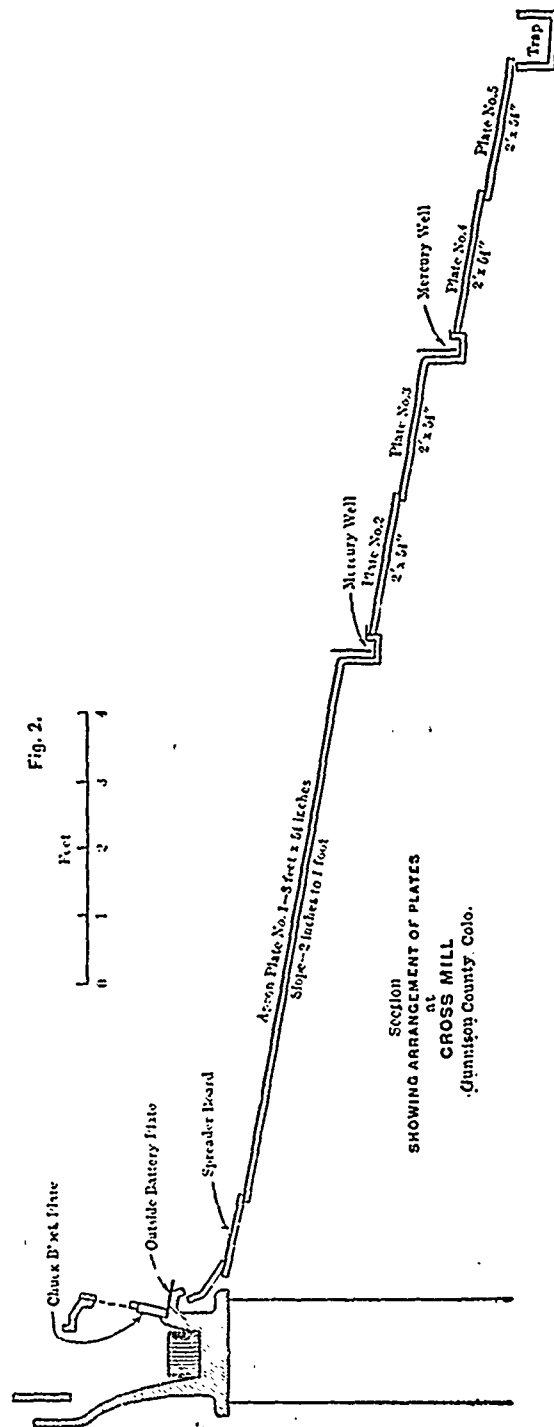

MINING NOTES.

Nova Scotia.

CAPE BRETON.

Mr. James Purvis, manager at the International colliery, has resigned his position to accept a position with the Sunny Brae and Country Harbor Railway, and is now in charge of a surveying party working from Country Harbor. He has been succeeded by Mr. Peter Christmson, superintendent at Gowrie colliery.

Hon. David Mackeen recently paid the Dominion Coal Co. collieries a visit in his official capacity as Consulting Director and Vice-President. The directors have also elected Mr. Mackeen a member of the executive committee.

Mr. Hill-Catherine, a mining engineer of London, England, has lately been in Sydney in the interests of some English capitalists, and has been investigating the new finds of coal at the rear of Cow Bay and the Mira districts.

The output of the Dominion Coal Co. Ltd. to the end of July was:

| | |
|-----------------|------------|
| Gowrie colliery | 4,556 tons |
| Caledonia | 39,797 " |
| International | 19,742 " |
| Dominion | 36,248 " |
| Old Bridgeport | 19,667 " |
| Reserve | 39,758 " |
| Victoria | 13,380 " |
| Hub | 17,987 " |

Total 191,135 tons

The shipments for July amounted to 173,039 tons. Largest day's output, 8,276 tons. Largest day's shipments, 7,817 tons.

CHETICAMP.

Messrs. Harrison Bros. et al are pushing the development of the galena lead, and fifteen tons of picked ore have been taken out to be shipped to the smelters, part going to Swansea and the other part to New York. The vein matter is a talcose schist, carrying argentiferous galena, arseno iron pyrites, copper pyrites. The lead up to the present is over 20 feet in width, and carries on an average 12 per cent. of lead, the silver running about an ounce to the unit of lead. Some samples which have been tested show small quantities of gold, which we are rather inclined to think is carried in the arseno iron pyrites. The clear sulphides carry from 50 to 60 per cent. of lead, the remaining per centage being made up by the above mentioned minerals. The property is an ideal one from a smelter's point of view, as it is near the coal, close to the sea border, and fluxes in the shape of fluorspar and lime stone abound in the vicinity.

GOLDENVILLE.

This once famous camp is beginning to assume its old time appearance. Tributaries on two areas of the Stuart-Hardman property obtained 130 ounces of gold last month; this, added to the 218 ounces for June, makes an exceedingly good showing, especially when we take into consideration that a considerable part of the month was occupied in putting in new gear.

The Blue Nose Co. returned 147 ounces last month, and Mr. J. A. Fraser is bringing up some very good looking ore just now.

A new find is reported in this neighborhood, but up to going to press we have been unable to obtain any reliable data.

CARIBOU.

The Guppy-Jennings Co. have struck some very good ore in their mine lately owned by Mr. W. A. Sanders. They express themselves as being very pleased with their purchase, and speak in the highest terms of Mr. Sander. A new shaft is being put down, which will cut to the vein at a depth of 400 feet. A complete survey of the property has recently been made by Mr. Alex. Dick, of Halifax.

Work at the Touquoy mine is being pushed forward. Two more pockets were met with last month, one carrying 10 ozs. and the other 30 ozs.

Another rich strike has been made at the Elk mine.

Manganese.—The Mineral Product Co. of New York have bonded the smelting plant at Bridgeville, and intend making ferro manganese on an extensive scale from wad manganese ore, near Hillsboro, N.B.

Copper.—Mr. W. S. George, manager for a New York syndicate, is opening up several copper properties in Cumberland Co.

Antimony.—We understand that Mr. Gould Northrup has sold the old antimony mines at Rawdon to an English syndicate.

Wood.—About 1/10 of a cord of dry spruce and pine was used per hour, or about 2/3 cord per ton of ore. This would indicate about 12 h. p. as the power required to operate the stamps. This could be greatly reduced by covering the boiler with a brick casing.

Capacity.—The capacity, of course, varied according to the nature of the ore. Sometimes it amounted to 1/10 of a ton per hour, where the ore was soft and decomposed. At other times it was only 1/10 of a ton per hour, when the ore was principally quartz. The average was 12 tons per 24 hours.

Water.—The apron plates were at first set on a slope of 1 1/2 inches to the foot, and, owing to the large amount of iron present, it was necessary at times to use as much as 3000 gallons of water per ton of ore. On setting the plates on a slope of 2 inches to the foot, this was reduced to 1000 or 1200 gallons per ton. The water supply is furnished by a 1 1/2-inch pipe line about 500 feet long, with a head of 30 feet, which is more than sufficient for all needs.

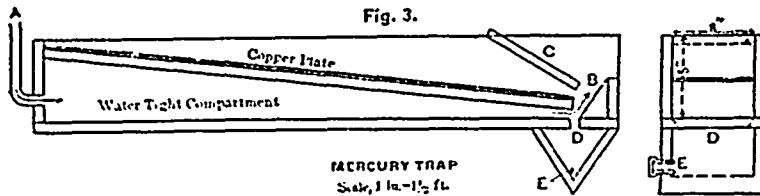

General Remarks.—Considerable objection has been offered by some based on the alleged liability of oil or oily water finding its way to the plates from the steam chest. At first, this did annoy us; but by keeping the packing of the piston in good condition, it was almost entirely avoided. As a precautionary measure, we substituted for the collar or flange attached to the stem to actuate the feeder-arm, as before explained, castings of similar form, only with the addition of a rim around the edge to form a cup. This cup was of sufficient size to extend out from the stem the same distance as did the tightening rings of the steam chest, so that any drip would fall into it. This was filled with cloth, which would absorb the drip as it fell, and was occasionally sprinkled with soap shavings or pearline, which emulsified the oil carried down. Graphite lubricator, manufactured by The Joseph Dixon Co., will probably soon be experimented with, and the results will be reported. A circumstance may be mentioned in this connection which may be of interest. At first, lye or caustic potash was used to destroy the oil, and a greenish scum would form on the plates which it was impossible to keep off. On entering the mill one day, a faint odor of ammonia was detected, and the idea suggested itself at once that there might be sufficient iron held in solution by the battery water, dissolved from the ore, to be acted upon by the ammonia generated by the chemical combination of the sal-ammoniac (used to clean the plates occasionally), with the caustic potash, and be precipitated as ferrous hydrate, Fe(OH)₂, forming the scum mentioned. Acting on this suggestion, samples of the water were filtered off from the tailings and treated with NH₄OH. The hydrate was precipitated in considerable quantity. As a check, other samples of the water were treated with K₂FeCy₆, and, after standing a few hours, the blue coloration was very strong. The use of lye was discontinued, and the scum disappeared.

After about 400 tons of ore had been crushed, a scale was formed on the apron plate (No. 1), composed of hard amalgam, making the plate work unevenly. This scale was removed, and the value of it was found to represent about 10 per cent. of the entire value of amalgam recovered from the plate, or about \$200, or 50 cents per ton of ore treated. Tests were made to determine the fineness in gold and silver of the bullion produced from this scale, as well as from the amalgam from the several plates, taking the three outside battery plates as one.

TABLE II—FINENESS OF BULLION FROM SCALE AND PLATES.

| Product. | Scale | Battery Plates | Apron Plate No 1 | Apron Plate No 2 | Apron Plate No 3 | Apron Plate No 4 | Apron Plate No 5. |
|-------------------|--------|----------------|------------------|------------------|------------------|------------------|-------------------|
| Amalgam (mg) | 560 | 300 | 1860 | 460 | 2880 | 2000 | 340 |
| Retort (mg) | 167 | 130 | 313 | 55 | 307 | 260 | 29 |
| Retort (per cent) | 32.1 | 31.8 | 22.2 | 13.1 | 15.3 | 13.0 | 14 |
| Gold (cents) | 830.9 | 827.7 | 781.2 | 575.5 | 566.0 | 555.5 | 547.4 |
| Silver | 159.1 | 172.3 | 218.8 | 424.4 | 413.4 | 442.2 | 472.5 |
| | 1600.0 | 1000.0 | 1000.0 | 1000.0 | 1000.0 | 1000.0 | 1000.0 |

The bullion was refined directly from the retort of the different samples, as the proportion existing between the gold and silver was all that was sought. The results show that the gold fineness decreases as distance is gained from the battery, also that the proportion of bullion to the amalgam also decreases in the same direction. The tool used to remove the scale from the plate was a common putty knife, having the blade cut off to about one-half its length, and dressed with a file to have a slight bevel. This edge was further dressed on an oil stone, so that it would loosen the scale without "scraping" so as to expose the copper. The plate was left in excellent condition, and, after a few hours, was perfectly normal.

After crushing 200 tons, the guide blocks, set in the top of the mortar, were considerably worn, especially at the front of the stem. Strips of old rubber belting were inserted in these openings to keep the stems in place, and were found to work admirably, obviating the necessity of putting in new guide blocks. These strips had to be renewed about every two weeks.

A number of tests were made to determine the percentage of possible amalgamation, which was found to range from 48 to 60 per cent., averaging 50 per cent. In actual practice, the percentage ranged from 40 to 55 per cent., averaging 45 per cent. It is safe to say, therefore, that the amalgamation was practically complete.

It would seem that the field of usefulness of the steam stamp in connection with amalgamation is bound to increase in proportion as it becomes better known.

Mercury.—The discovery of native mercury on the banks of the Dartmouth Lakes, has created a considerable amount of excitement. We will reserve comment on this find until we have seen it, which we hope to do shortly; but the fact remains that mercury is to be found directly under the moss over a considerable area, although no trace of cinnabar has up to date been found associated with it. It is of course a matter of history that large quantities of mercury were allowed to go to waste in the early milling operations in this province, and it is, we are disposed to think, within the range of possibility that some of the Montague mercury has reached the shores of the Dartmouth Lakes. We don't for one moment wish to throw cold water on this find, as it is one of very considerable interest, and most certainly deserves looking into closely. We may incidentally mention that Mr. W. L. Libbey found mercury in a decomposed state in Queen's County, associated with small quantities of cinnabar, and in panning for gold in Hants County Slates we have found small quantities of cinnabar; but neither of these two latter cases have been of anything but scientific interest, the quantity being too small to be of value.

ISAAC'S HARBOR.

The Richardson mine produced 247 ounces of gold last month. Several tons of concentrates from this mine have been shipped to Swansea for treatment.

Mr. Giffin, of Isaac's Harbor, has been in Halifax for some time, forming a company to start development work on a property near the Richardson. Mr. Giffin informed us that he has cut the lead in several places, disclosing some very promising ore.

BROOKFIELD.

The North Brookfield Mining Co. Ltd. produced a brick of over three hundred ounces last month. The company are now stowing their concentrates, with the intention of chlorinating them in the autumn. The mine is not producing a sufficient quantity of concentrates to keep the chlorination work continually running with any degree of economy, and the company have wisely adopted the plan of running the chlorination plant at intervals only.

We hear on going to press that another pocket, valued at \$5,000, has been struck at the old Touquoy mine. This ore will be on view at the Provincial Exhibition.

MONTAGUE.

In a single shot, Messrs. Oland Bros took out over \$1,000 worth of gold from the Symon Kaye property. This gold was taken from the Skeney lead, at a depth of 17 feet from the surface. The Symon Kaye was bought some years ago by an English syndicate, from Messrs. Oland Bros., who ran it for a time at a loss; the mine was finally sold and re-purchased by the Oland Bros., who are now proving its worth.

The Golden Group Co. are pushing forward development work at Montague, and are just now in very good ore.

CHESTER BASIN.

Mr. Damas Touquoy is reported to have made a good find of gold in this locality. Some years ago Mr. Touquoy found a very rich boulder, and since the sale of his property in Moose River this spring he has been prospecting for the lead from which the boulder came.

Mr. Baker cleaned up \$2 ounces of gold from 8½ tons of ore.

Ontario.

Messrs. Aemilius Jarvis & Co. report under date of 1st August:

The past month has been marked by quiet but steady business, and whilst transactions have not been numerous, they have taken place upon a more satisfactory and business-like basis. The Yukon craze has happily almost entirely eliminated the unhealthy elements that have prejudicially affected the satisfactory extension of business in Ontario properties. The relative value of the raw material and capital are becoming more generally and accurately understood by location holders, and the necessity of permitting a sufficient period for careful and exhaustive examination by the buyer is now generally recognized. The majority of holders are prepared to deal upon equitable and often generous terms, and it is not likely that good propositions in the district will in the future be offered under conditions more advantageous to the buyer. The unnecessary secrecy of companies like the Sultana and Regina; the unexpected delays that have arisen, the characteristic of new districts and inexperienced handling, in the case of properties like the Ferguson, Lucky Coon, Randolph, etc., and the disappointments of others like the Empress and the Foley, are all factors that have tended to bring owners to a sensible basis.

The 100 square miles acquired under the Ingledue deal are being handled by the "Ontario Government Gold Concessions Company." Two gangs, one for each division, are going in during the first week in August, under the direction of local engineers, to prospect the area. It is stated the company intend to expend about \$6,000 per month in this work, and deposits have been made at a local bank. It is to be borne in mind that this expenditure

is not to develop known auriferous locations, but merely to prospect in undeveloped territory. The capitalists at the back of this company evidently have great faith in the district.

The issue of new Saw Bill capital was readily taken up, and the shares have been in demand: On the other hand the applications for Foley shares have not been as numerous as was expected.

Prices for leading shares have shown little elasticity, the closing quotations for the month being: Saw Bill, \$2.75 to \$2.80; Hawk Bay, 90c. to \$1; Empress, 5c., nominal; Foley, \$1.50 to \$2.00, nominal; Bannockburn, 25c. to 30c.; Princess, 20c. to 25c.; Hammond Reef, 30c. to 35c.

Locations in prospectors' hands have had fairly ready sale, most transactions being on an "interest for development basis." A large purchase by American capital is also recorded. In partly developed properties there have been few fresh transactions, and most have been put upon a part cash and a part share basis.

H. W. 271 in the Manitou is opening up well, showing a 7½ ft. reef carrying visible gold all down the 15 feet of shaft already sunk. On the Ambrose a contract for a 200 ft. shaft has been let. A. L. 66 and 67 in the Saw Bill district is opening up better than expected, and shows a well developed reef, traced for over 2,000 feet, 50 feet wide, giving an average of \$10 ore. On H. W. 54 of the 65 ft. level the 7 ft. reef has widened to over 13 ft., with assay values, averaged from assays of all part of shaft, running over \$50. This vein is traced for over a mile. On N. C. 28 new shafts are down, one over 50 ft., the other over 60 ft., and driving at the 50 ft. level to connect is well advanced. In the drives the reef shows up 35 ft. wide, and the ore averages \$12 to \$14. H. W. 130 reports showing up well. The shaft is now down over 50 ft., and the vein which is 7 ft. at surface has widened at the 50 ft. level to 11 ft., whilst the ore averages \$20. The work on the Kabaskonge has demonstrated an immense body of ore, the reef extending for 2,000 ft., running over 100 ft. in width, and has been tested to a depth of 100 ft. from the cap. The lowest representative assay is reported over \$6, and the prospect would appear to be a large low grade ore. 224 and 225 D, adjoining the Regina, have been bought by Duluth capital, as has also the Winnipeg Consolidated Company's mine, which has been closed down since 1885. On the Wampun the reef, which preliminary test pits showed to carry a well defined reef 3 ft. to 4 ft. wide, is opening up well, and the shaft, now down over 40 ft., shows a widening vein very similar to the Saw Bill. On the Hiawatha No. 3 vein at 35 ft. down has increased to 4 ft. in width, and is well mineralized, panning gold freely. Reports from the Saw Bill continue very rose colored, and the public has certainly good reason for expecting most satisfactory results when once crushing begins. The cyanide plant on the Regina, which was installed by the Cassel Gold Extracting Co., is now working very satisfactorily and the advisability of enlarging the mill capacity is under consideration.

On the Mikado all buildings are up and machinery erected, and milling is expected to commence early in August. The assays from this property showed very high grade ore, 4½ oz. to 10 oz. to the ton. The first 238 tons crushed, however, yielded about \$15,000. The average of this mine as now opened up is not expected to run as high as this; it is nevertheless high-grade ore. The property consists of about 323 acres, and the company is an English one.

The new mill and machinery on the Sultana is going up fast, and development is reported as continuing satisfactory. Work on the Empress is for the present entirely suspended. It is to be hoped, alike in the interests of the shareholders and the district, that a policy of masterly inactivity will only be temporary.

Latest from the Hawk Bay shows mine not looking so well, the vein at the bottom of shaft having pinched very considerably. It should of course be borne in mind that the vein varies much on the surface, and the same characteristics may reasonably be expected at lower levels. On the Hammond Folger the mill is far advanced, and crushings may be looked for in September. The formation is shattered granite, and the fissures quartz filled. Whilst free gold is in places visible, this property is probably low grade. The great extent of the deposit will ensure good net returns from a very low average. It is a question of stamp power.

The Foley is undermanned, and consequently has the mill running for only 10 hours per day. The company's reports in the hands of the shareholders are eminently satisfactory. The record of mismanaged properties is growing wearily monotonous in its consistent regularity. In the present instance, local mismanagement has been accentuated by an exhibition of harlequinade finance, which has placed the company in what is euphemistically styled an "undoubtedly unhealthy condition." No one is likely to deny that a company that is not only reconstructed on a basis that gives "no provision for treasury stock to provide necessary working capital," and has to raise money "in the shape of loans" to continue work, but actually starts by assuming "as it was difficult to present full statement at the time," the responsibility of some \$16,000 odd plus further sums unknown, which subsequently turned out to be some \$8,000 odd, is in an "undoubtedly unhealthy condition." The property itself, though not showing the wonderful wealth eulogistic reports heralded, appears to be a thoroughly good one.

During the month letters patent have been issued incorporating the following companies:—

The Gold King Mining Company of Toronto, Limited. Capital \$2,000,000, in \$1 shares.

The Eureka Gold Mining Company, Limited. Capital \$100,000, in \$1 shares.

The Soo Mining and Exploring Company of Algoma. Capital \$90,000, in \$1 shares.

The Oriole Gold Company of Wabigoon, Limited. Capital \$24,000, \$50 a share.

An officer of the Foley Mines Co. Limited, writes:

"Since we have had any communication with you we have increased the capital stock of the company by fifty thousand new shares, of the par value of five dollars each, and have issued to shareholders only thirty-six thousand of new stock, at a discount of sixty per cent., making a total amount of capital of the company outstanding, \$1,180,000, and leaving unissued in the treasury 14,000 shares of stock, representing a capital of seventy thousand dollars. We have our new 12 drill compressor plant, which is being furnished by the Canadian Rand Drill Company, well under way, and we expect to have it in operation by the beginning of October. Mr. William M. Strong, M.E., has been appointed General Superintendent, with full charge of everything at the mines, at a salary of \$175 per month. Mr. Foley desired to be relieved from the responsibility, and has accepted the position of Inspector and Consulting Advisor of the Board at the mines, at a salary of \$100 per month, where his long experience of the district in question will make him extremely useful to the company. Mr. Strong comes to us very highly recommended, as an engineer of repute, and of experience in free milling properties, both in Colorado and California. Mr. Flaherty has retired from our employment, after having done the company excellent service. The results since the beginning of May have been very disappointing, on account of our inability to keep our mill running anything like continuously. We are advised that it was practically impossible to get competent miners, capable of stopping ore in narrow veins, and with experience of that character, at any reasonable figures, and those we did get wanted unreasonable wages, were generally incompetent, and preferred to go prospecting with the opening of navigation rather than accept what was fair. We consider that the new compressor plant will reduce the expense of operation at the mine, and will not leave us at the mercy or caprice of any small body of miners. Of course, in Colorado and California, where there are plenty of mining camps, it is easy enough to get experienced miners; but if you have to pay their expenses up into the new country like ours, and you have no police regulations whereby if they break their contracts to work with you you could deal with them summarily, you are practically at their mercy after they have been with you a short time. With railroad and telegraphic communication this of course in time will be obviated to a considerable extent. These difficulties are usually attendant on a new enterprise in a new district, and we seem to have had more than our share. We are advised that the north shaft, on which they are working day and night is now down 245 feet, the vein is 5 feet wide and looks splendid. We hope to reach the three hundred foot level by the first of October, and we hope to have our compressor plant in operation not later than the beginning of October. With our new manager, with the experience we have gained in dealing with the difficulties of the situation in the past three years, and with the new plant, we feel satisfied that at an early date we will begin to realize the good opinion which all those who have visited the property have so far formed of it."

The Mikado mine, which has attracted so much attention to the possibilities of the Lake of the Woods district as a gold producer, was opened up in July, 1896. Work has been pushed for the last twelve months with great perseverance, and a 20-stamp mill is now ready to commence work on the ore mined. The vein is situated in the contact of the schist and granite. A shaft has been sunk to a depth of 125 ft., and a crosscut of 35 ft. on the 100-ft. level has been made, which proves the vein to be holding its original promising indications. In the month of October, 1896, about 300 tons of the ore were shipped to the reduction works at Rat Portage, and an average return was obtained of 2½ oz. per ton. The mill has been erected under the superintendence of the manager, Mr. Theodore Briedenbach. He has had some 20 years' experience in various gold fields, and is a graduate of the Academy of Mines, Berlin. The mill is one of 20 stamps, of Fraser & Chalmers make, the stamps being 850 lbs. apiece. The crusher is also of Messrs. Fraser & Chalmers' Comet pattern. The tailings are to be run direct from the amalgamating plates to leaching cyanide tanks, the concentrates being very heavy.

An Order-in-Council has been passed, which gives the Burley Gold Mining Company of Ottawa, the right to construct a crib in Lake of the Woods opposite the Sultana mine, for the purpose of sinking a shaft. The matter is rather an interesting one. The Burley Company, which is composed chiefly of Ottawa men, holds a mining location on the surface of Lake of the Woods. The location is believed to include the prolongation of the Sultana lode beneath the lake. They accordingly applied to the Dominion for a permit to put a crib in the lake. The permit has now been granted, and the company will get to work to put down the crib work, beneath which to sink a shaft to the vein, which is over 100 ft. beneath the bottom of the lake.

Quebec.

The Central Quebec Gold Fields Company is a newly incorporated concern, whose aim is to work for gold in the Beauce region. Messrs. James King, W. Vuille, Montreal, J. L. Tache, St. Hyacinthe; J. P. Tache, Quebec, are its chief promoters.

The principal operators continue to be the Wallingford Co. and the Blackburn Estate in Templeton.

The feldspar deposit at Templeton station continues to make shipments to the States where the product is being used in the manufacture of pottery.

In Ottawa County the exports of mica for the six months have increased to \$54,322 but as the Customs figures are well known to be understated it is not unlikely that the value of the product shipped is in excess of \$100,000.

The argentiferous-galenite property, known as the Lawn mine, on Calumet Island, Pontiac Co., is reported sold to two Americans named Meyer, from New York and Los Angeles. The new owners state that work will be commenced at once.

The shipments of asbestos and chromite from the mines of the Eastern Townships for the six months are about the same as in former years. The demand for asbestos continues good, and there is a slight improvement in prices, notably for second grade.

British Columbia.

The Cariboo Hydraulic Company, which made a clean-up of over \$72,000, will soon be ready to make another of about the same amount, and will probably wash about \$200,000 this season. The Horsefly Hydraulic Company, after washing for the first year, in which it took out \$65,000, found that there was too much cement in the ground for successful operations by this method, put in a ten-stamp mill, which started July 10th, and crushes 120 tons a day. In the same camp the Miocene Mining Company, a San Francisco outfit, with Senator Campbell at its head, has a shaft down 240 feet, sinking for the bed of the old channel, and has put in machinery to sink deeper. The theory of a number of experts is that the old channel is here 1,000 feet wide, and that the Fraser, Clearwater, Quesnelle, and perhaps other streams formerly passed through it. This theory is well borne out by the fact that the Horsefly Gold Mining Company has shown the present channel of the Horsefly river to be simply a cross-cut of the old channel. This mine is being worked by two hydraulic elevators, and will make a good showing. Nearly 40 miles of this old channel have now been located.

Colonel Baker, Minister of Mines, has given notice of an amendment to the Mineral Act, which defines the meaning of the phrase "mineral in place." The Minister of Mines has accepted the interpretation of the full court in the Paris Bell case. The section reads: "Rock in place shall be deemed to mean and include minerals not necessarily in a vein or lode, that is when discovered in the same place or position in which it was originally formed or deposited, as distinguished from loose, fragmentary or broken rock or float, which by decomposition is found in wash gravel or sand. Valuable deposits of mineral shall mean and include mineral in place in appreciable quantity, having a present or prospective value sufficient to justify exploration."

A suit has been filed in the United States Court, Spokane, Wash., making sensational charges of fraud and dishonesty against F. C. Loring, G. T. Crane and F. E. Snodgrass, of the Josie Gold Mining Company. The company's mine is at Rosland, B.C. The plaintiffs are Eli J. Smith, R. N. Gage, William Kniekel, John Wetzel, Jr., John Wetzel, John Loebis, Jacob Schlaefer, Mathias Schneider and Mrs. E. J. Smith, all citizens of Wisconsin. The complaint sets forth that the Josie Mining Company was organized at Neenah, Winnebago County, under the laws of the State of Wisconsin, and upon representations made by Loring and Crane, the plaintiffs bought a five-eighths interest in the mine for \$8,000. It is charged that the mine was worked under the supervision of Loring and Crane, who systematically depreciated the value of the property, spent large sums of money uselessly, and did not attempt to develop the property. The plaintiffs ask for the appointment of a receiver, and a restraining order taking entire control of the mine out of the hands of the present management. The value of the Josie mine is now estimated at about \$210,000.

The coking ovens of the Messrs. Dunsmuir, at Union, Comox, B.C., are now working with entire satisfaction. The output of these ovens is about fifty tons per day, forty of which are shipped to the Hall smelter at Nelson, and the Trail smelter, both of which would consume a much greater quantity were it possible to procure the same. These establishments pronounce the home-made coke equal in every respect to that imported from Wales, and the Horn to this port. Where tested in the United States the Union coke has likewise been declared to be a first-class article. The ovens will hereafter be run to their full capacity. The industry promises to be a great one, and of much value to the province.

The old War Eagle Company will pay its last dividend in a few days. The War Eagle, it will be recalled, sold its mine to a Canadian syndicate and afterwards disincorporated. Treasurer Lucas was at work yesterday calculating the value of the remaining assets, and said that there would be about \$22,500 to be distributed among the former shareholders. This would give a 4½ per cent. dividend. Since the mine was sold for \$700,000 it has paid a dividend of six cents a share, or \$30,000. There are 500,000 shares of the stock, so that when the final dividend has been paid the owners will have received a trifle more than \$1.50 a share as the proceeds of the sale. Prior to the sale the mine had paid \$187,000 in dividends. So, all told, the War Eagle mine has returned its owners \$940,000. This, for an expenditure of about \$300,000, is not bad, being a little more than 31 for 1. But the original owners did better than that. The original War Eagle Company owned the War Eagle, the Iron Mask, the Virginia, and the Poorman. The big company was cut up into four companies, and the stockholders in the original company received shares in each of the new companies equal in number to their holdings of original War Eagle stock. Thus the owner of 25,000 shares of War Eagle stock received in addition to these shares, 25,000 shares in the Iron Mask, 25,000 in the Virginia, and 25,000 in the Poorman. At one time Iron Mask sold briskly around 75 cents, and some shares were sold as high as 85 cents. Virginia sold for 20, and Poorman for 12 to 14. So original owners

who sold at these figures received more than \$2.50 per share for their original holding. Mining men just down from Rosslund report that the War Eagle and the Iron Mask are showing up well under development. It is said the owners of the War Eagle expect to push development work for two years before trying to pay dividends, and that they expect then to enter upon a long period of dividend paying.

At the Le Roi, Captain Hall, the superintendent, reports the lowest working level of this mine to be at a depth of 500 feet. The principal levels are at 350, 400, 450 and 500 ft., respectively, and the 600 ft. level will shortly be opened up. The shaft itself is a three compartment one, 4 x 5 ft. The great development began to show itself at the 300 and 400 ft. levels, but is more strongly visible in the 450 and 500 ft. levels. Mr. N. T. Trelgear is in immediate charge of the lower levels. From one of these drifts, commenced only a few weeks ago, ore has been shipped at the rate of 100 tons per day.

Ventilation is now good. The compressor runs 3 pumps, 2 hoists and 18 drills, all in connection with the workings of the mine. Calcite is particularly noticeable on the face of the west tunnel at the 500 ft. level, which is being extended toward the Big Bear claim owned by the Le Roi Company, and where is located the big compressor, the "Senator." This west tunnel is all in ore. First-class ore consists of nearly massive fine-grained pyrrhotite and copper pyrites, sometimes with a little magnetite or mispickel with more or less quartz and calcite. The value of this ore is given at \$53.05 net per ton. The bulk of the ore, however, is second class, and it runs from \$27.97 to \$40. The company employs 180 men, and it has a pay roll of \$15,000 per month. Since last September it has expended at least \$100,000 in building improvements and machinery, and at least a similar amount for labor. The Le Roi has already paid dividends amounting to \$450,000 to date. Its capital is represented by 500,000 shares at the par value of \$5 each, being a total of \$2,500,000.

NELSON.

Everything in this neighborhood seems pointing to prosperity; new residences and business blocks are rapidly being built, and everyone seems confident now that we have at last entered on a most successful period of our history—one that will be lasting. There is no "boom;" just going ahead quickly and substantially, which all reasonable people will admit is by far the better sign of permanence.

Perhaps the most favourable sign of all, is that the Pilot Bay smelter so long closed down has passed into the hands of the Omaha and Grant Co., who intend to re-open very shortly, and probably add another furnace or two. It was a most melancholy sight that your correspondent saw on a recent visit there. Good, well arranged machinery all going to ruin for want of use, and well built houses spoiling in the same fashion. It is a very good example, however, of what mismanagement and ignorance of smelting will bring the best made smelter to look like, and it might be well worth the while of some other people who think they can manage a smelting concern without the slightest knowledge of the matter, to take a lesson from it, "read, mark, learn and inwardly digest" that lesson, and alter their methods accordingly.

Report says that the new owners do not intend to do much with the Blue Bell mine, which is a very low grade proposition, but to deal more with the Slocan and Ainsworth ores, which will no doubt help out the old Hot Springs camp considerably. The fact of starting another smelter will also materially assist Nelson itself, as that town will be the basis of supplies for a long time to come.

In Ainsworth itself, development work is being proceeded with steadily, and with a market for her ores within easy reach by water carriage to Pilot Bay, no doubt will very soon more than double her shipping, as it is the cost of the long haul to the States that renders much of the product unprofitable. Just give a low freight rate, and much more of the lower grade ore will prove a source of revenue.

Near Lemon creek, which, although in the Slocan district, is very commonly reached from Nelson, recent valuable strikes are reported, running well up in silver, although from the surface only, and it would be no matter of surprise if the more valuable yellow nickel were found to accompany its poor despised white consort.

The Athabasca group, on Toad mountain, has been steadily shipping ore to the Hall mines smelter, and sent down during July about 80 tons. This is a quartz proposition, carrying pyrites and a little galena, running quite rich enough in silver and gold to leave a comfortable margin of profit for the owners.

The Fern mine, near Hall creek, is also looking very well, and a 20-stamp mill is now in course of erection. Quite recently another lead was discovered, of very much decomposed quartz, that assays well in gold, which should add considerably to the value of the shares.

The Silver King group (Hall Mines Co.) is still in great form, and is turning out from 200 to 250 tons of smelting ore per day. This amount is necessary to keep the 200-ton blast furnace at the smelter working to its full capacity. The new furnace in question was blown in about the 31st July, and with the exception of the usual trifling details always accompanying the blowing in of a new furnace, has been working most successfully ever since, and shows a very considerable saving in fuel over the smaller one, which will very possibly be used for lead smelting in the near future. The manufacture of blister copper (as it is called; it is really of a much higher grade) is being proceeded with steadily, and it is in contemplation to add another reverberatory furnace for use on matte only, so as to quicken the production of the metal. The method employed is to crush and roast the matte from

the blast furnace (originally about 46 per cent. copper), then to smelt this crushed and roasted matte in the reverberatory, and produce "white metal," carrying about 60 to 65 per cent. copper. This white metal is again crushed and roasted, and smelted in the reverberatory into metallic copper. It may appear to some people that this arrangement might be altered somewhat with much advantage, but "every one to his taste."

I regret to say that Mr. Paul Johnson, the superintendent from the very beginning, has accepted a more important and valuable post in Mexico, and that the Hall Mines Company will shortly lose his services. A good superintendent, thoroughly familiar with all the strings, is hard to get, and in these days it is so much easier to lose money than to make it, even for smelting purposes, that Mr. Johnson's successor will have no soft snap for the first few months.

Some gentlemen from England, the Messrs. Wilson Bros., have quite lately bonded an important group of claims about nine miles from Nelson, known as the Last Chance group, near Cottonwood Lake, and have put a force of 10 or 12 men on to develop. The rock is white quartz, a very well-defined vein widening as it goes deeper, and carrying iron and copper pyrites with considerable gold and silver. Assays made right from the surface showed 10 per cent. copper, \$5 in gold, and considerable silver. The lead has a splendid location, and the ore could be most easily transferred to the railway, hardly more than a mile distant. If this turns out as well as it looks it will be another valuable assistance in building up the prosperity of our town.

The long looked for Crow's Nest Pass Railway has at last actually commenced, and is expected to be open in about two years throughout its whole length, though of course sections will be worked before that time. In addition to the Crow's Nest, the branch line from the Slocan Lake to the C.P.R., Nelson and Robson line is being pushed forward with all speed, and the engineer in charge hopes to have all in running order by the middle of October next. This line will be a great convenience, and should prove a very profitable branch of the C.P.R., but it is, of course, to the main line of the Crow's Nest that we must look for supplies of cheaper fuel. I have not seen any analyses of the coal from that district, but have been credibly informed that it is a very clean and first-rate coking coal. If so, it will be gladly welcomed by all smelting men.

A very strong company has been organized to utilize some of the power (hitherto wasted) at the Great Falls on the Kootenay river, between Nelson and Robson. These falls have been re-christened "Bonnington Falls," and a large force of men are now engaged there blasting rocks and preparing a site for a very large electrical plant, which, it is intended, will be powerful enough to provide sufficient current not only to light up all West Kootenay, but also to run smelters, or, at any rate, replace steam as the motive power in them. There is no question as to the *bona fides* of the company, though whether they will be able to accomplish all they expect, may perhaps be doubtful. At any rate it is a new departure, and will have nothing but a good effect on the district, and as such it is most welcome.

A rumor is current that a very fine ledge has been found on the Morning mountain (adjoining, or part of, Toad mountain), which runs as high as 200 oz. silver and \$20 in gold. It is very difficult to obtain the real facts of these statements; quite possibly they are correct, but prospectors' words, and indeed those of mine owners themselves, are not always to be implicitly relied on. However, in this instance, a great deal of work has been done on the claims, which would scarcely have been done if there had not been sufficient grounds for it, and it is sincerely to be hoped that the statement is true.

The Klondyke naturally attracts much attention here, but very few, indeed, have left for that slightly inhospitable region. Indeed, one has as good a chance here as there to make some money, and does not have to pack a year's grub about with him or starve. But the furthest field is the greenest as usual, and certainly the idea of picking up nuggets and dust by the bucketful without machinery or capital, must be a great inducement to many.

It may be of interest to call attention to the Customs' revenue for July last; the total duty collected from the Nelson district being no less than \$30,723, and some odd cents, or about \$1,000 daily. The value of the ore exported is placed at \$288,625, and that of the matte at \$315,207, odd cents omitted. These figures appear to show conclusively that West Kootenay is all right, and as long as that is the case Nelson and district will share in the prosperity.

A. H. HOLDICH.

NELSON, 21st August, 1897.

VANCOUVER.

A big citizens' meeting, held in Victoria, has pronounced emphatically in favor of the future restriction of Yukon gold mining to British subjects, whilst also urging a big reduction of the proposed royalty charges. These are the sentiments undoubtedly of all British Columbians with few exceptions, and since the meeting the Victoria "Colonist," the Provincial Government organ of British Columbia, and on the whole the most influential newspaper in the province, has emphatically endorsed the same views editorially, and commended them for consideration to Ottawa. The "Colonist" however properly suggests that the restriction of future gold mining in the Yukon to British subjects should be accompanied by a confirmation of existing rights and contingent rights of American miners now in the Yukon; otherwise great injustice would be done, against which the United States might and would sturdily protest. Americans now in the Yukon should, it is urged, be registered and allowed full miners' rights, but future settlement

for mining should be reserved for British subjects, on the grounds that the Yukon is no country for the permanent settlement of aliens who might thereafter become valuable British subjects, and that the mineral wealth once gotten out of the Yukon cannot be substituted. Hence Canada should, in the main, reserve it for British subjects, just as the United States reserve their mines for their own people in most of the states and territories. Such is general British Columbia opinion. The royalties of 10 and 20 per cent. are everywhere in the province regarded as altogether excessive for so very hard and costly a country as the Yukon.

It is also strongly urged that the Dominion agents in British Columbia be permitted to issue miners' licenses for the Yukon district of the North-West Territories, in order to enable prospectors to explore districts that may be far from the present Klondyke placers, without having to travel, it may be, hundreds of miles through most difficult country, in order to find a Dominion agent for the issue of mine licenses. This would prove a great convenience for Yukon prospectors passing through British Columbia en route for the gold country.

Although large numbers of prospectors are still making through British Columbia for the Yukon via the mountain and lake route from Dyea, a host will undoubtedly return home to await the coming of spring ere making a renewed effort to enter the country. The pass and trail are blocked by hundreds of prospectors, horses and cattle, and hundreds of tons of freight. The rain falls in torrents and winter is fast approaching the Yukon, whither adequate supplies cannot now be sent, whilst it is freely predicted by old time Yukoners now in British Columbia, that not one in ten of those now seeking the country via Dyea, will get in ere winter. At least 2000 persons are now making for the Yukon by that route, and those who do not promptly return to winter in the coast cities, will in most cases have to spend a long period of enforced inaction, camped in tents by the lakes half way towards their destination at best. The rigor of an arctic winter, endured under such circumstances, will prove the death of large numbers, and all who know, expect terrible suffering amongst the Yukon wayfarers this winter.

The coast and island mines, now steadily developing, will soon badly need smelting and refining facilities at or near Vancouver, but so far no syndicate has offered to meet this requirement save at a cost to the city in money bonus and tax exemption, which the Council will not endorse for the citizens' ratification or otherwise. A bonus of \$100,000 in cash appears to be the minimum asked, and the city will not vote more than about \$50,000, and this sum only under conditions that will ensure not only smelter and refinery construction but also operation.

VANCOUVER, Aug. 16th, 1897.

N. C. SCHON.

BOUNDARY CREEK.

Mining operations are decidedly active at present. Much more work is being done than ever before in the history of the district. This district, with the surrounding territory on all sides of it, is making rapid progress.

In the vicinity of Christina lake to the east, new towns are springing up, and valuable discoveries are reported.

To the south on the Reservation, Eureka camp is enjoying a boom. Messrs. Clark, Finch & Neil own some properties there, which they claim are extremely high grade and free milling. At any rate they are spending a great deal of money in blocking out ore, but as the properties are stocked and the stock boomed on the market, some are uncharitable enough to wonder if it is all true. At any rate Eureka camp is the mecca for the Reservation mining men at present.

Corbin has a corps of engineers surveying for railroad construction to the camp, and as Eureka is but 14 miles from midway we may have an American R.R. into Boundary Creek before the C.P.R. is aware. The establishment of the smelter at Northport is likely to be an inducement to R.R. construction for Corbin.

In speaking of Reservation properties, special mention should be made of Lone Star and Washington, which lie across the border adjoining White's camp on the Canadian side. These gold copper properties are being steadily and systematically developed under Mr. Henry White's management. Those who have been through them say they give every promise of being mines.

The Golden Crown tunnel is in 150 ft. 15 men are working on the property.

An important deal has been made on the Anaconda groups of claims belonging to Mr. E. A. Bielanberg. The Powys Co., an English company, of which Mr. E. M. Muuns is manager, and Mr. Alfred Woodhouse, engineer, has paid \$1000 cash and undertaken to expend \$1000 monthly in development and pay \$1000 more for a half interest with an option on the remaining half. These properties are high grade gold and copper and adjoin the properties of the B. C. M. & M. Co. on the north.

One of the most promising prospects in the district which was discovered just this spring is the B.C. in Summit camp. The Messrs. Keough were prospecting, when they uncovered some fine copper ore. On finding that the ground was located they covered the ore and purchased the claim for \$500. After making some cross-cuts they have bonded the property for \$60,000. According to the statements of all who have seen the property it is a bonanza. The vein is 20 feet wide, opened up for 300 feet. The ore is chalcopryrite and bornite, in a gangue of lime, quartz and specularite. Samples carefully taken across the vein yield 12 to 14 per cent. copper, 10 to 12 ozs. silver, and \$3 to \$5 in gold per ton. The property is bonded to the Mines Selection Co., of London. They have 90 days in which to make a 10 per cent. payment on a year's bond. Mr. A. L. McEwan, engineer for the company, has ten men at work on the ground now.

To the west of us lie Camp McKinney and Fairview, where active mining is being carried on. Beyond Fairview, up the Similkameen and Tulameen, important discoveries are being made in quartz and copper ores.

A rich chute has been struck on the Republic, Smith's camp, at a depth of 100 feet. The quartz is beautiful, with coarse gold.

GREENWOOD, B.C., Aug. 21st.

G.

Dow's Flat

1856.

Dows' Flat. That's its name.
And I reckon that you
Are a stranger? The same?
Well, I thought it was true.

For thar isn't a man on the street as can't spot the
place at first view.

It was called after Dow,—
Which the same was an ass;
And as to the how

That the thing kem to pass,—
Just tie up yonr hoss to that buckeye, and set ye
down here in the grass:

You see, this 'yer Dow,
Hed the worst kind of luck:
He slipped up somehow
On each thing thet he struck.
Why, ef he'd 'a' straddled thet fence-rail, the
dermed thing 'ed get up and buck.

He mined on the bar
Till he couldn't pay rates;
And right on the top of his trouble kem his wife
and five kids from the States.

It was rough,—mighty rough;
But the boys they stood by.
And they brought him the stuff
For a house, on the sly;
And the old woman—well, she did washing, and
took on when no one was nigh.

But this yer luck of Dow's
Was so powerful mean,
That the spring near his house
Dried up on the green;
And he sunk forty feet down for water, but nary a
drop to be seen.

Then the bar petered out,
And the boys wouldn't stay;
And the chills got about,
And his wife fell away;
But Dow, in his well, kept a-peggin' in his usual
ridikilous way.

One day,—it was June,—
And a year ago, jest,—
This Dow kem at noon
To his work like the rest,
With a shovel and pick on his shoulder, and a der-
ringer hid in his breast.

He goes to the well;
And he stands on the brink,
And stops for a spell
Just to listen and think:
For the sun in his eyes (jest like this, sir!), you
see, kinder made the cuss blink.

His two ragged gals
In the gulch were at play,
And a gownd that was Sal's
Kinder flapped on a bay;
Not much for a man to be leavin', but his all,—as
I've heer'd the folks say.

And—that's a peart hoss
Thet you've got,—ain't it now?
What might be her cost?
Eh? Oh! Well, then, Dow—
Let's see,—well, that forty-foot grave wasn't his,
sir, that day, anyhow.

For a blow of his pick
Sorter caved in the side;
And he looked, and turned sick,
Then he trembled and cried.
For, you see, the dern cuss had struck—"Water?"
—Beg your pardon, young man, there you lied!

It was gold, in the quartz,
And it ran all alike;
And I reckon five oughts
Was the worth of that strike;
And that house with the coopilow's his'n,—which
the same isn't bad for a Pike.

Thet's why its Dow's Flat;
And the thing of it is,
Thet he kinder got thet
Through sheer contrairiness:
For 'twas water the derned cuss was seekin', and
his luck made him certain to miss.

Thet's so. Thar's your way
To the left of yon tree:
But—a—look h'yur, say?
Won't you come up to tea?
No? Well, then the next time you're passin'; and
ask after Dow,—and thet's me.

Roofing Felt for Brattices.—An exchange states that for forming the brattices of air conduits in headings, roofing felt is an excellent, and at the same time cheap, material, as it can be very easily put on, and yield to any thrust of the measures without its air-tightness being impaired. For putting up the felt a narrow board is fastened, in the direction of the centre line of heading or cross-cut, at the floor and also at the roof, to the props that form the partition of the air compartment, to which boards the roofing felt is nailed; and, for increasing the tightness, a coat of cement is given at the roof, and also, it may be presumed, at the floor. If the heading should happen to be unusually high, a third board must also be nailed, for the sake of strength, in the middle of the height. Experience has shown, observes *Gluckauf*, of Essen-an-der-Ruhr, that if a firedamp explosion should occur an air partition made with roofing felt will remain absolutely intact at some little distance from the seat of explosion, whereas one consisting of boards would be completely destroyed. If, when the air conduit is no longer required, the felt be carefully removed from the boards with a flat fork-shaped tool, it can be used again two or three times over. Air conduits may also be formed of impregnated flax cloth, nailed inside wood frames, that may have any desired dimensions, and fitting telescopically one inside the other, being fastened by screws.

Cariboo Mining, Milling and Smelting Co.—The noted Cariboo mine at Camp McKinney is still doing well, as the following statements indicate, which were made at a recent meeting of the Cariboo Mining Company, held in Spokane. Manager Monahan then made the following statement regarding the operations of the company during the past year: During the past twelve months there have been 6,742 tons of ore milled, producing 8,035 ounces of bullion and 170 tons of concentrates; the ore milled has averaged \$17.45 per ton. There have been 855 feet of drifting on ore, and 100 feet of raising on ore; 200 feet development cross cutting; 175 feet development shafting; 50 feet development winze sinking, making 425 feet of developing. The company has recently put in a lot of new machinery, and the mine is now thoroughly equipped in every respect. Since operations were first commenced \$156,963.76 have been paid in dividends.

Briquettes without Pitch.—In a recent issue we took notice of a new hardening composition called "Petrifite," which has the property of binding an solidifying without pressure almost any ordinary substance with which it is combined. In order to test thoroughly its suitability for briquette making, Mr. H. S. Fearon has been advised to make certain tests, which have accordingly been carried out, and the results are altogether favourable to the use of petrifite instead of pitch for solidifying small coal. He found that with about 3% per cent. of petrifite the briquettes burnt well in an open grate, and with less smoke than is usual with briquettes made with pitch.

Moreover, the blocks are not hygroscopic to any extent worth mentioning, for on immersing in water for 24 hours they had only taken up 6 per cent. of their weight of water, and after 48 hours only 6 1/4 per cent. in all, nor were they softened in the least by the immersion. Mr. Fearon estimates that the cost of turning out 120 tons of fuel per day, exclusive of the cost of the coal dust, would be as follows:—Labor, 7d. per ton, fuel used in manufacture 8 1/2d., petrifite, 110 lbs., 2s. 6d., repairs and maintenance, 7 1/2d., stores and supplies, 2 3/4d., or about 4s. 7d. per ton. To arrive at the cost of a ton of briquettes, there must be added to this the cost of 2,130 lbs. of coal dust, which varies from a merely nominal price up to 10s. per ton, according to locality and quality.

The Deepest Bore-Hole—The deepest bore-hole in the world, says Mr. C. Zundel, is one of 6,751 feet below the surface of the soil, made at Paruschowitz, Upper Silesia. The previous record for depth was the hole drilled some years ago at Schladebach, near Leipsig. The latter bore-hole was made in a search for coal measures; and 83 separate seams, some of considerable thickness, were penetrated. The hole was 12 inches in diameter at the beginning, and this was lined with a tube about 0.4 inch thick; at a depth of 230 feet the bore was reduced to 8 1/4 inches in diameter, and this continued for 351 feet. At this point the blue marl encountered became so compact that the diamond drill had to be used, and, under the action of the water, the marl swelled to such a degree that the diameter of the pipe had to be again reduced. The greatest difficulty encountered was the great weight of the boring rods, as the depth increased. Though steel was used, at a depth of 6,560 feet the total weight of the rods reached 30,155 lbs. Under this weight ruptures of the rods were frequent, and an accident of this nature finally stopped the work; about 4,500 feet of rods fell to the bottom, and, being jammed under a part of the tubing, it was impossible to withdraw it. The diameter of the well at the bottom was 2 3/4 inches. Temperature observations made showed 12 deg. C., or 15 deg. F., at the surface, and at a depth of 6,571 feet the temperature reached 69.3 deg. C., or 157 deg. F. This is equivalent to an average augmentation of heat of 1 deg. C. for every 34.14 metres of depth, or 1 deg. F. for every 63 feet. The boring at Paruschowitz was commenced on March 26th, 1892, and it reached its maximum depth in 399 working days.

Some of the gentlemen who have started for Alaska insufficiently grubstaked will live to appreciate the following translation from the Klondyke classics:

"Nothing ventured, nothing gained,"
He caroled as he started.
When he returned, he sighed: "A fool
And his money soon are parted."

MODERN HOISTING PLANTS..

FROM 15 TO 500 HORSE POWER. ROUND OR FLAT ROPE. FRICTION OR GEARED.



ELECTRIC HOISTING

AND

PUMPING PLANTS..

SEND FOR SPECIAL CIRCULAR OF OUR "BOSS" HOISTING PLANT FOR PROSPECTING.

DENVER ENGINEERING WORKS

DENVER, COLORADO, U. S. A.

The Hall Mines New Copper Furnace.—The large copper furnace at the Hall mines has been running smoothly since being blown in Saturday morning. During the first five days' running, up to six o'clock Thursday morning, 2,250,020 pounds of Silver King ore were put through the furnace, producing 215,934 pounds of matte.

This furnace was designed by Paul Johnson, the company's smelter superintendent, and is said to be the largest copper furnace in the world. Mr. Johnson estimates that the operation of the new furnace will effect a saving of ten per cent. on the company's previous smelting expenses, and that by its use the Hall mines can smelt copper ores as cheaply as any smelter in Colorado, despite the difference in the cost of fuel. To the Hall mines the use of this furnace will mean a saving of at least \$1,500 per month upon smelting expenses. Superintendent Johnson is highly pleased with the success which has attended the blowing in and operation of the furnace. Piece by piece he has built a very economical smelter, and under his personal supervision the working of the same has been the most creditable of the Hall mines operations. It is evident that in securing Mr. Johnson the Hall Mines Company was most fortunate.

When the big furnace was started there was a good supply of ore in the bins, and as the tramway is bringing down 210 tons per day, it is thought that a long and profitable run will be made. There is an ore reserve of

3,000 tons at the mine, and if pushed, the tramway can deliver 275 tons every 24 hours. The management is of the opinion that ore will be produced at the mine in sufficient quantities to keep the furnace running six months. This would mean a handsome earning for the company, as the ore now being taken out of the mine carries much greater values than any which the company has treated for several months past. The reverberatory furnace is working up large quantities of white metal, and will shortly commence working the same over into copper. It is not unlikely that another reverberatory will be added, so that one furnace can be used exclusively for white metal, and the second for copper.

British-Canadian Mining Companies.—Out of the 450 companies registered at Somerset House during July, 22 are for the purpose of carrying out mining operations in the Dominion of Canada, the total income amounting to £956,114. In several cases the registered capital was of a purely nominal amount.

St. Lawrence Coal Receipts from Cape Breton.—During the month of July the Dominion Coal Co. shipped 132,000 tons to the St. Lawrence ports. The trade in the Province of Quebec is expanding, and a little coal is gradually finding its way into Ontario.



**SURVEYING, MINING
AND
ENGINEERING ; ; ;
INSTRUMENTS. ; ; ;**

Accurate and Most Improved . . .



MINING TRANSITS.

Complete Line of Engineers
Instruments and Supplies.
Reasonable Prices. SEND
FOR CATALOGUE.

Hearn & Harrison
NOTRE DAME ST.,
MONTREAL, QUE.

MINING MACHINERY FOR SALE.

A lot of Mining and Mill Machinery, consisting of 16 x 24 Rand Compressor; Ingersoll and Rand Rock Drills, single and double drum; Bacon Duplex Hoisting Engines; Mill Engine; Steam and Air Pipe (3½ in. to 1 in., about 3,000 ft.); Blake Crusher and special crushing machinery for Asbestos Fibreizing; Blake and Knowles Steam Pumps; Boom and Cable Derricks; Steel Hoisting Ropes, Galvanized Guy Ropes, Shafting, Pulleys, Belts, Pit Cars, Steel Rails, and a miscellaneous lot of tools, the whole valued at \$25,000, being the property of the American Asbestos Co., in liquidation.

Parties interested in mining or rock work of any description will find this an excellent opportunity to equip their works with modern machinery as good as new. Some of the machinery has only been in use a little over three years, and some of it was placed in the summer of 1896.

For full particulars apply to

JOHN J. PENHALE,
R. R. BURRAGE,
Joint Liquidators.

P.O. Box 96, Sherbrooke, Que.

JEFFREY



Roller Chains, Steel Drag,
Steel Cable and Special Chains
—FOR—
**ELEVATING
AND CONVEYING
MACHINERY**
FOR HANDLING MATERIAL OF ALL KINDS

**POWER TRANSMISSION
MACHINERY.**

SHAFTING,
PULLEYS,
FLANGERS,
CLUTCHES,
DUCKETS,
EOLDS,
BOOTS.

**WIRE CABLE
CONVEYORS.**
For long and short
distance conveying.

THE JEFFREY MFG. CO. 163 Washington St.
NEW YORK.
Columbus, Ohio. Send for Catalogue.

Boiler and Pipe Coverings The most Efficient and Durable Non-conducting Coverings in the world

FIRE-PROOF. EASILY APPLIED.

ASBESTOS MATERIALS
of all kinds
Wicking, Fibre
Mill Board
Felt, Packing, Cement
Liquid Paints
Roof Paints
Fire-Proof Paints, etc.



We are prepared to take contracts for applying Steam Pipe and Boiler Coverings in any part of the United States.

H. W. JOHNS MFG. Co.
100 WILLIAM ST., NEW YORK.
CHICAGO. PHILADELPHIA. BOSTON.

MONTREAL ROLLING MILLS CO.

MONTREAL

ALL GOODS BEAR OUR



Manufacturers of Bar Iron, Steel, Wrought Iron Pipe, Cut Wire
Nails, Horse Shoes, Lead Pipe, White Lead, Shot, &c.

WORKS: LACHINE CANAL.

OFFICE: 3080 NOTRE DAME ST.

If you want . . . **BAGS** For Packing . . .

Asbestos, Phosphates, Ores, Etc.,

SEND TO US FOR SAMPLES AND PRICES.

*Every Quality and Size in Stock . . .
Specially Strong Sewing for heavy materials
Lowest Prices compatible with Good Work.*

We now supply most of the Mining Companies, and those who have not bought from us would find it to their advantage to do so.

The Canada Jute Company, Ltd.

17, 19 & 21 ST. MARTIN STREET, MONTREAL.

Canada Atlantic Ry.

THE SHORT FAVORITE ROUTE

BETWEEN

Ottawa and Montreal.

6 TRAINS DAILY 6
EXCEPT SUNDAY
And Sunday Train Both Directions

PULLMAN BUFFET PARLOR CARS

Close Connections at Montreal with Trains for

Quebec, Halifax, Portland

And all Points EAST and SOUTH.

FAST THROUGH SERVICE BETWEEN

Ottawa, New York and Boston

And all NEW ENGLAND POINTS.

Through Sleepers between Ottawa and New York.

Baggage checked to all points and passed by customs in transit.
For tickets, time tables and information, apply to nearest ticket agent of this company or connecting lines.

E. J. CHAMBERLIN,
General Manager.

C. J. SMITH,
Gen. Passenger Agt

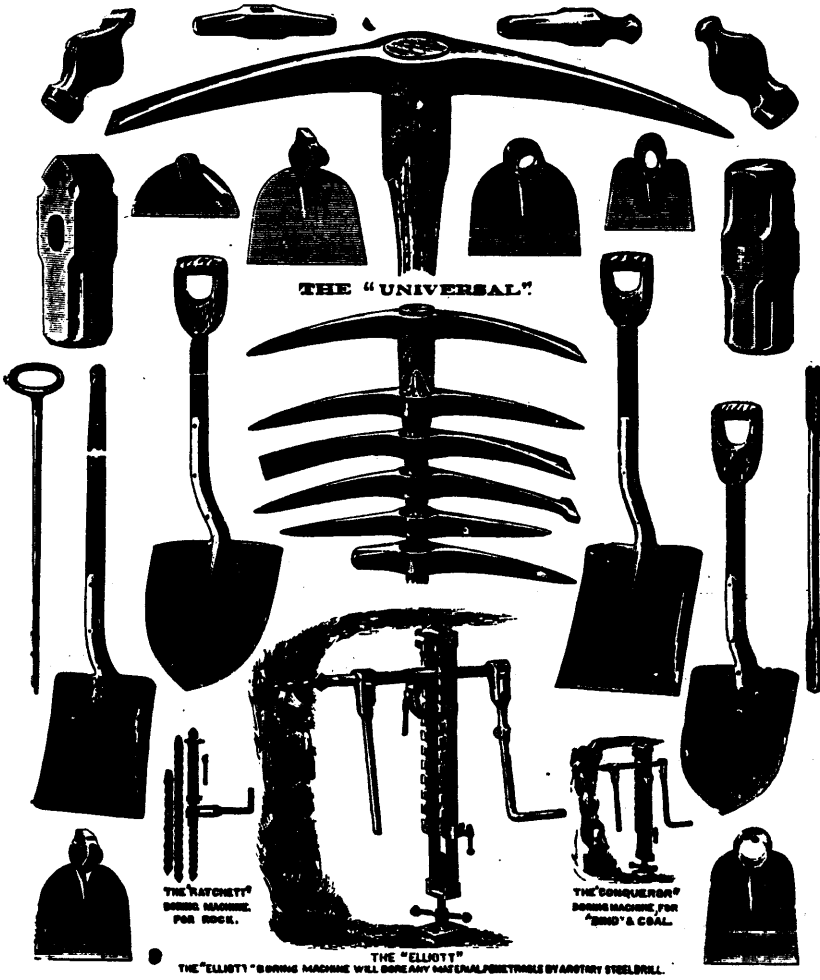

SPECIAL TOUGH MINERS DRILL STEEL.

The Hardy Patent Pick Co., Limited
SHEFFIELD, ENGLAND.

REDDAWAY'S PATENT

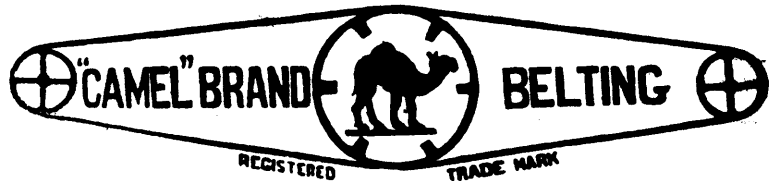

Specially Adapted for Heavy Drives in Damp or Exposed Places, in Mines, Saw Mills, Paper and Pulp Mills, Etc.

CHEAPER, LIGHTER, MORE PLIABLE and MORE DURABLE THAN DOUBLE LEATHER

W. A. FLEMING, Sole Agent for Canada

27 St. Francois Xavier Street, Montreal

Victoria Chambers, Ottawa.

THOUSANDS NOW IN USE OVER THE WORLD . . .



TRUAX Patent Improved
AUTOMATIC ORE CARS.

THEY ARE THE BEST AND CHEAPEST.

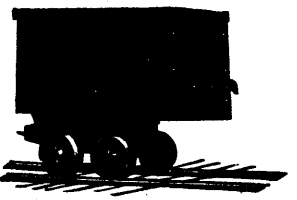

TRUAX M'F'G CO., Denver, Col.

The Only Exclusive Ore Car Manufacturer in America.

Pat. Jan. 5, '02, Aug. 2

Send for Catalogue, or Call on your Dealer for Truax Cars.

School of Practical Science, Toronto

ESTABLISHED 1878.

AFFILIATED TO THE UNIVERSITY OF TORONTO.

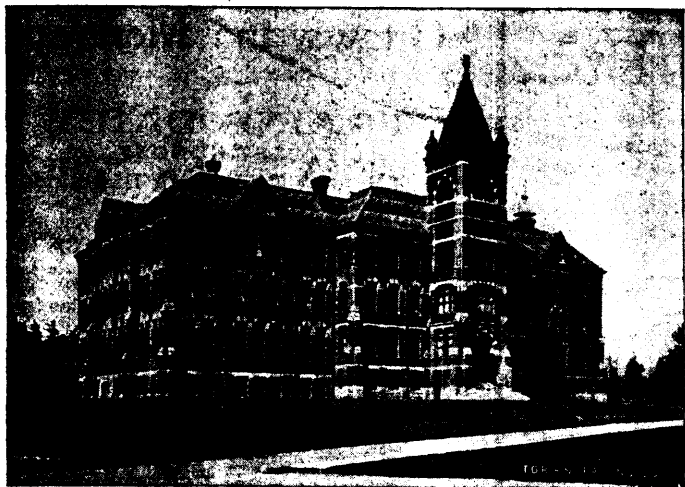

This School is equipped and supported entirely by the Province of Ontario and gives instruction in the following departments:

- 1—CIVIL ENGINEERING
- 2—MINING ENGINEERING
- 3—MECHANICAL & ELECTRICAL ENGINEERING
- 4—ARCHITECTURE
- 5—ANALYTICAL AND APPLIED CHEMISTRY

Special Attention is directed to the Facilities possessed by the School for giving Instruction in Mining Engineering. Practical Instruction is given in Drawing and Surveying, and in the following Laboratories:

- 1—CHEMICAL
- 2—ASSAYING
- 3—MILLING
- 4—STEAM
- 5—METROLOGICAL
- 6—ELECTRICAL
- 7—TESTING

The School also has good collections of Minerals, Rocks and Fossils. Special Students will be received as well as those taking regular courses.

FOR FULL INFORMATION SEE CALENDAR.

L. B. STEWART, Secretary.

E. Leonard & Sons, London, Ontario

MONTREAL, QUE.

ST. JOHN, N.B.

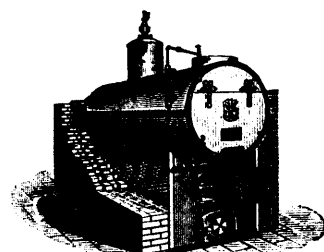
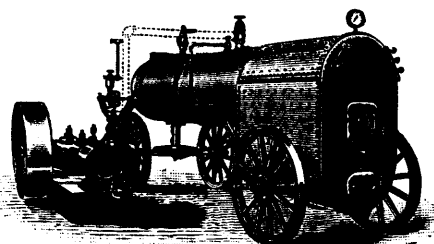
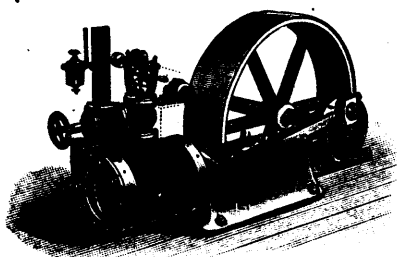

MANUFACTURERS OF

ENGINES AND BOILERS IN LARGE VARIETIES.

Send for Quotations on any size from 3 H.P. to 250 H.P.

Send for new Catalogue mentioning this Paper.

Chemical and Assay Apparatus



NEW ILLUSTRATED CATALOGUE JUST ISSUED, SEND FOR A COPY.

COMPLETE ASSAY OUTFITS.

THE HAMILTON-MERRITT PROSPECTOR'S OUTFITS.

Becker's Balances and Weights.

Battersea Crucibles and Muffles.

Hoskins' Gasoline Furnaces.

Kavaheer's Bohemian Glassware.

Munktell's Swedish Filters.

Lyman, Sons & Company

380, 382, 384, and 386 ST. PAUL STREET,
MONTREAL.

R. T. Hopper & Co.

SUCCESSORS TO IRWIN, HOPPER AND CO.
ESTABLISHED 1878.

MINERS AND SHIPPERS OF MINERALS, ETC.

31 Board of Trade Building, MONTREAL, Can.

Asbestos, Crude and Manufactured, Mica, Plumbago, Soapstone, Etc.

Also MANAGING DIRECTORS AND
SELLING AGENTS FOR

The Anglo-Canadian Asbestos Company, Ltd.

Loughboro Mica Mining Company, Ltd.

The English Portland Cement Company, Ltd.

Montreal and Kootenay Mining Company, Ltd.

Johnson's Company, Ltd.

Miners of Crude Asbestos.

The output per annum of Asbestos from these mines, in addition to being the largest, not only in Canada, but in any part of the world, is unsurpassed both in quality and length of fibre. The facilities for shipping the crude ore are most advantageous, the properties being situated alongside the railway, thereby enabling all orders to be filled promptly.

Mines at Thetford Station, Quebec Central Railway.

EMBOSSED METAL CEILINGS.

These Ceilings are Made from Mild Annealed Steel Plates, in a Great Variety of Designs, Suitable for Every Description of Buildings, including

**HOSPITALS,
CHURCHES,
SCHOOLS,
CONVENTS,
OPERA HOUSES,
ASYLUMS,
OFFICES,
STORES,
RESIDENCES, Etc.**

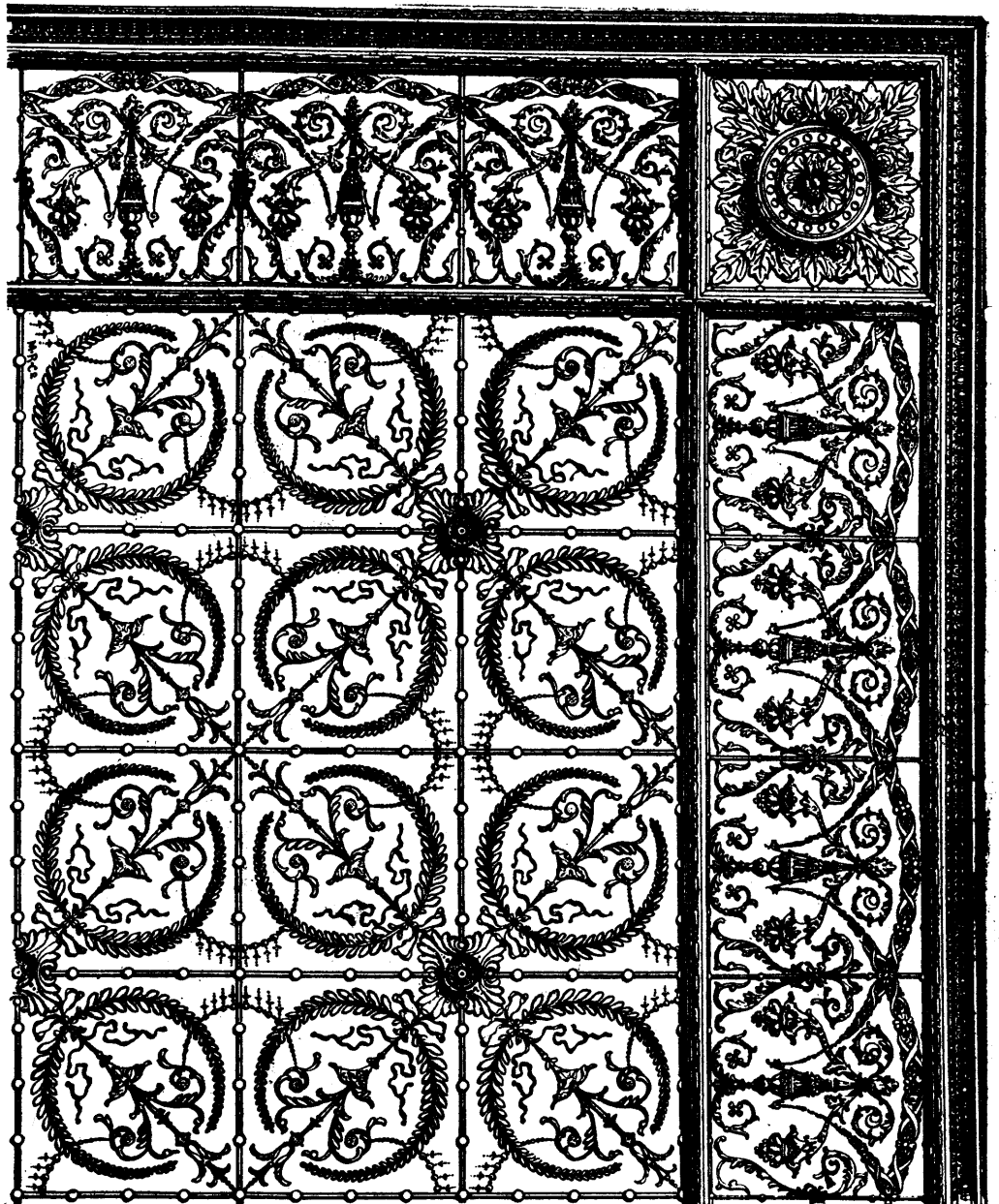

ONE OF OUR DESIGNS.

The many advantages of their use as a modern substitute for Wood or Plaster, lies in the fact that they are light in weight will not crack nor drop off, consequently no danger of falling plaster; are unquestionably durable, have air-tight joints, are easily applied, are practically fire-proof, are highly artistic, do not harbor vermin or the germs of disease, and possess splendid acoustic properties, in addition to many other points of excellence over any other form of interior decoration.

.... WRITE FOR CATALOGUE "K"

The METALLIC ROOFING CO., Limited,

COR. KING and DUFFERIN STREETS,

SOLE MANUFACTURERS.

TORONTO, ONT.

BOUNDARY CREEK MINING AND MILLING CO.

INCORPORATED OCTOBER 21st, 1896.

CAPITAL, \$1,500,000.

1,500,000 SHARES AT \$1.00 PER SHARE.

700,000 Shares in the Treasury for Development.

This Company owns and operates a group of the highest grade in Gold, Silver and Copper properties in Boundry Creek.

CLAIMS—The G. A. R., D.A., O. B., S. H. B., J. A. C., FRED D., S. F., C.S. & H., D.H. and BIG LEDGE, constitute the group, which is the most compact and advantageously situated of any under one ownership in Boundry Creek. The proposed Columbia and Western R.R. being surveyed to pass right through Greenwood City and along the base of the hill.

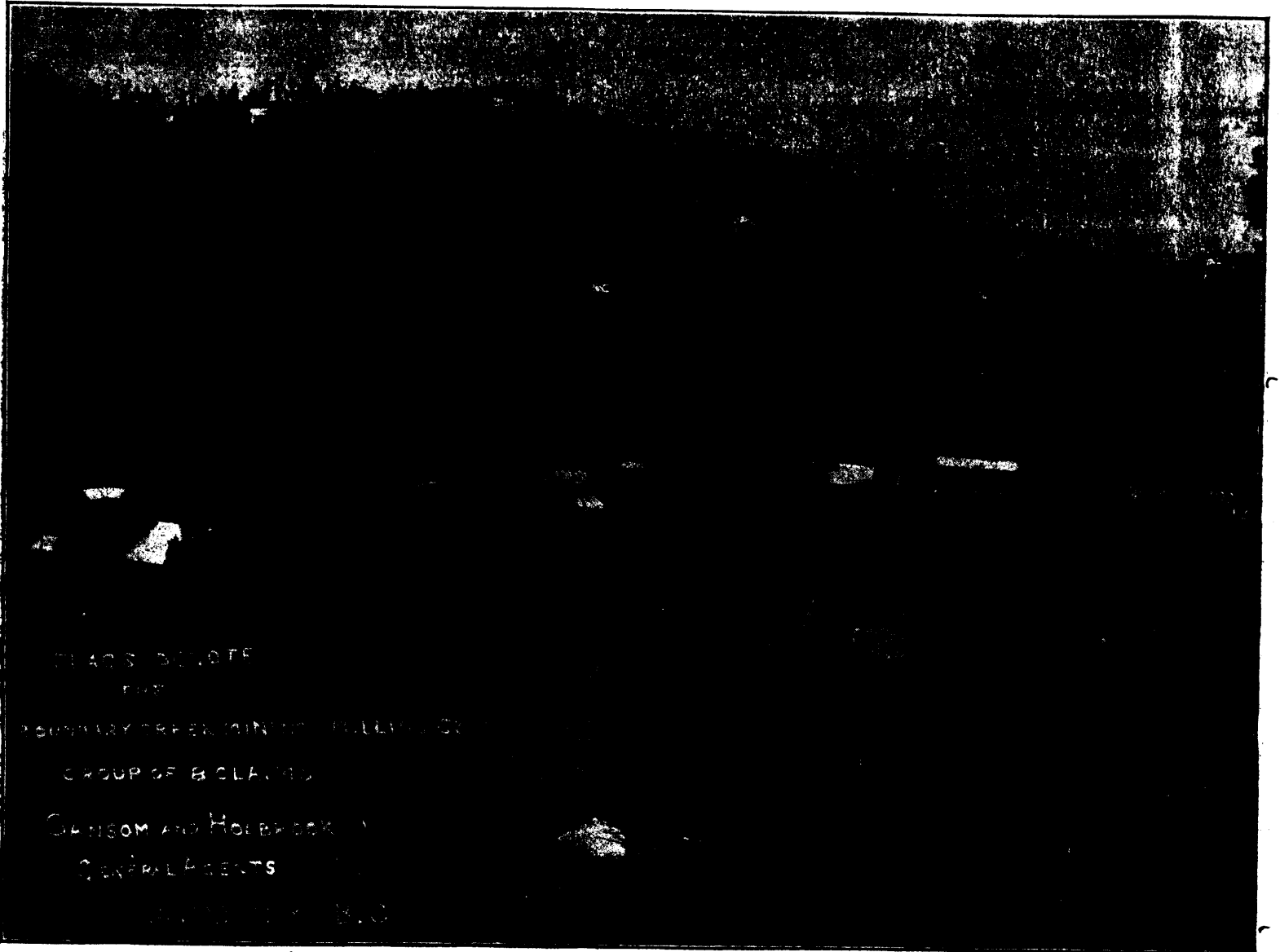

From the above photograph it will be readily seen that, lying as they do on a steep sloping hill, the properties offer unusually good facilities for drainage and rapid and economical development, by main working tunnels driven in from the base of the hill.

The veins lie in the Granite Area—which occupies the upper part of Boundary Creek basin—along the line of contact with the more basic eruptures, and are among the oldest locations in the camp.

A small shipment of 8,653 lbs. was made to the Everett smelter in 1894, yielding per ton, Gold, \$103.15; Silver, 74-7-10 ozs.; Lead, two per cent., and a considerable amount of shipping ore is at present on the dumps of the different claims.

Careful investigation is earnestly invited by the Company, as their properties are being developed with a view to making mines and not to booming stock.

Attention is drawn to the large amount of stock (700,000 shares) put into the Treasury, and to the fact that the properties are all fully paid for.

150,000 Treasury shares fully paid up and non-assessable, have been put on the market at 10 cents, and most of the stock so far sold has been taken up locally. A large proportion of the miners now working are also taking stock in payment. For further particulars address

BOUNDARY CREEK MINING AND MILLING CO.

SANSOM & HOLBROOK - GREENWOOD CITY, B.C.

THE QUEEN CITY OIL CO. LIMITED
TORONTO

SAMUEL ROGERS, Pres.

Wholesale Dealers and Manufacturers of Fine Quality Lubricating Oils for Engines, Dynamos, Drills and Mining Machinery.

OUR OWN BRANDS

"PEERLESS" ENGINE CYLINDER DYNAMO OILS

And the Finest Imported American, Cylinder, Dynamo, Engine and Machine Oils.

Correspondence cheerfully answered. Our long experience is at your service.
 Granite, Electric Light and Paraffine Wax Candles.

CANADA;
 Province of Quebec,
 District of Athabasca.

IN THE SUPERIOR COURT.

No. 125.

IN THE MATTER OF

The American Asbestos Company, Limited,

IN LIQUIDATION

The undersigned Joint-Liquidator will sell by

PUBLIC AUCTION

at the office of Messrs. ROYER & BURRAGE,
 87 Wellington Street, Sherbrooke, Que, at
 eleven of the clock in the forenoon,
 on the

EIGHTH DAY OF SEPTEMBER NEXT, 1897

the Asbestos Mining Property and Plant of the
 said Company, at Black Lake, in the
 Province of Quebec,

situate upon the parcel of land known and distinguished as the southerly ends or halves of lots number twenty-seven and twenty-eight, in range B of the Township of Coleraine, in the County of Megantic, containing about one hundred and four acres of land.

The property is situated about one mile from Black Lake, on the Quebec Central Railway, on the main road leading from Black Lake to Thetford mines. It is in the midst of the asbestos bearing belt of serpentine from which the greater part of the world's supply of asbestos is mined. The mine has been operated by the American Asbestos Company since 1888, and has been a steady producer of a very fine grade of asbestos, nearly the whole of the output of the mine since that time having been supplied to prominent European manufacturers of asbestos goods. The property is splendidly situated and well adapted for the purposes of asbestos mining, and is thoroughly equipped with the most modern machinery for the economical handling of the rock and manipulating of the fibre. Special machinery was placed last year for fiberizing, the result proving very satisfactory. There are a number of workmen's dwellings on the property, sufficient to accommodate a large number of men.

The machinery consists of four steel boilers (300 h.p.), 16 x 24 Rand air compressor, 6 Ingersoll & Rand rock drills, 4 duplex Bacon winding engines, Blake rock breaker, special crusher for fiberizing asbestos, Blake and Knowles steam pumps, boom and cable derricks, ropes, pitcars, steel rails, and a miscellaneous lot of tools, the total value of plant and improvements amounting to about \$45,000.

Tenders for the property will be received up to the date of sale, the Joint-Liquidator reserving the right to accept any such tender and withdraw the property from sale, and further reserving the right to place an upset price upon the property at such sale, and make such other conditions as they may see fit. The property is open to inspection at any time. Inventory can be seen, and any further information will be furnished on application to the undersigned.

JOHN J. PENHALE,
 R. R. BURRAGE,

Joint-Liquidator

Sherbrooke, Que., May 31st, 1897.

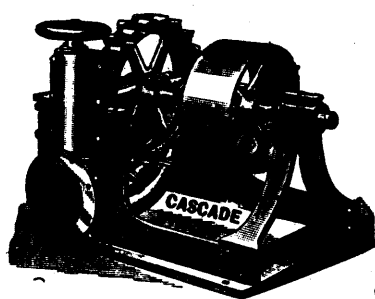

WATER WHEEL

ADAPTED TO ALL HEADS FROM

3 FEET TO 2000 FEET.

Our experience of 33 years building Water Wheels enables us to suit every requirement of Water Power Plants. We guarantee satisfaction. Send for Pamphlet, state Head, and write full particulars.

JAMES LEFFEL & CO., Springfield, Ohio, U. S. A.

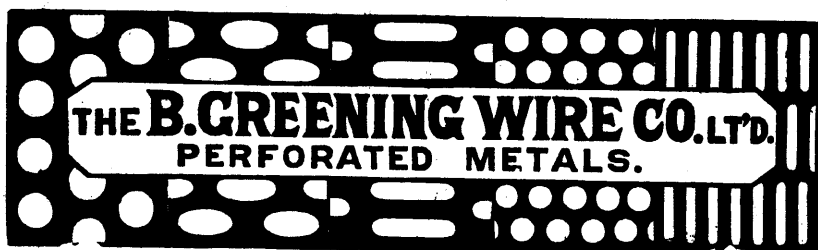

THE B. GREENING WIRE CO. LTD.
 PERFORATED METALS.

HAMILTON, ONTARIO.

Mine Locomotives

JEFFREY...

Locomotives, Screens
 Coal Cutters, Drills
 Tipples, Elevators, are
LEADERS

Send for
 Catalogue

THE JEFFREY MFG. CO.
 Columbus, O.

JEFFREY LATEST COAL CUTTER.

WINN & HOLLAND MONTREAL

SOLE AGENTS IN CANADA FOR

CYANIDE OF POTASSIUM

For Mining Purposes.

"Johnston's" Cyanide.

MAY & BAKER, Limited,

London, Eng.,

Sole Manufacturers.

PROFILE TOOL STEEL

For ROCK DRILLS

And other MINING TOOLS

J. BEARDSHAW & SON, Ltd.,

Sheffield, Eng.

ADVANTAGES

Steel as it comes from the rolls ready to cut into lengths and grind to tools. No Forging nor wasting in the fire. Saving in time and over 50 per cent. in weight of steel used.

WIRE ROPE

MINING ROPES Iron or Steel a Specialty.

JOS. CRADOCK & Co.,

Wakefield, Eng.

Original Makers and Introdurers of LANG'S Patent.

The McCully Rock and Ore Crusher....

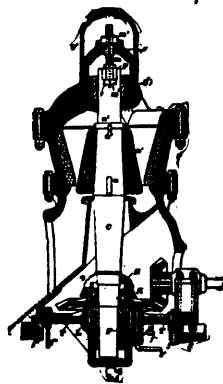
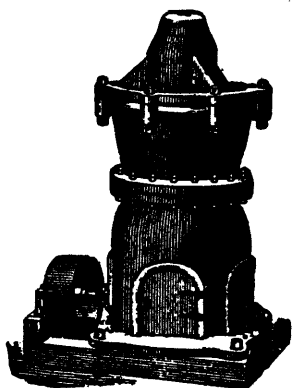
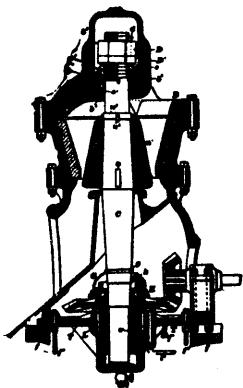

Central Shaft with Crusher-Head supported from top instead of at lower end.

GUARANTEED to do more work with one-half less power than any other Crusher now known.

Received two awards at the World's Columbian Exposition at Chicago, Medal and Diplomas. The only awards given for this type of Crusher.

Also received an award and medal at the "Mid-Winter Fair," San Francisco, Cal.

Send for Catalogue or further information to

Patented in
Canada and United States.

Waterous,

BRANTFORD, CANADA

Canadian Manufacturers of the McCully Rock Crusher

NOW READY

OUR

Directory to
Canadian Mining
Companies . . .

Price: \$4.00 Postpaid.

Canadian Mining Review,
OTTAWA.

"Eagle Parlor"

Matches

Smokers and Housekeepers alike find them faultless.

Their odorless qualities make them luxuries to use.

The E. B. Eddy Co. Ltd.

Full Montreal-Coronto.

THE SNOW STEAM PUMP WORKS,

MANUFACTURERS OF

Steam Pumps, Pumping Engines and Hydraulic Machinery.

General Agents for Canada, DRUMMOND, McCALL & CO., Montreal,
Local Agent F. R. MENDENHALL, Rossland, B. C.

Pumps Kept in Stock at Montreal and Rossland.

MONTREAL CAR WHEEL COMPANY,

MANUFACTURERS OF

RAILROAD CAR WHEELS

Street Car and Lumber Truck Wheels a Specialty.

Offices: CANADA LIFE BUILDING, MONTREAL.

Works: LACHINE, QUE.

THOMAS J. DRUMMOND, General Manager.

CANADA IRON FURNACE COMPANY, Limited,

—: MANUFACTURERS OF :—

CHARCOAL PIG IRON

(From the Famous Ores of the Three Rivers District.)

Offices: Canada Life Building, Montreal, Que.

GEORGE E. DRUMMOND, Managing Director.

Plants at RADNOR FORGES, QUE., GRANDES PILES, QUE., LAC-A-LA-TORTUE, QUE., THREE RIVERS, QUE., LA PECHE, QUE.

MONTREAL PIPE FOUNDRY CO. LIMITED,

(SUCCESSORS TO DRUMMOND, McCALL PIPE FOUNDRY CO. LIMITED)

MANUFACTURERS OF

Cast Iron Pipes



Special Castings, &c.

OFFICES: CANADA LIFE BUILDING, MONTREAL.

“Ludlow” Hydrants, Valves, &c. St. George Culleys and Sewer Traps, and All Water and Gas Works Castings.

The Dominion Wire Rope Co. Ltd.

MONTREAL

MANUFACTURERS OF

"LANG'S" PATENT WIRE ROPES FOR COLLIERY AND GENERAL MINING PURPOSES.

BLEICHERT TRAMWAYS

Manufactured and Constructed Under Patentees Rights.

ALSO ALL CLASSES AND KINDS OF WIRE ROPES FOR ALL PURPOSES.

Send for New Catalogue and Estimates to P. O. Box 2274.

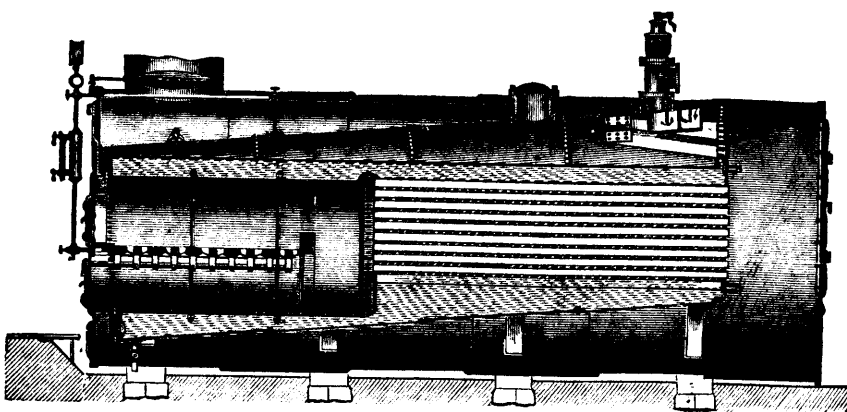

The Monarch Economic Boiler,

Is Portable

Has an outer casing and requires no Brickwork. Leaves our Shop mounted on skids ready for use.

Saves Fuel

Some tests show a saving of 30 per cent. over a common brick-set boiler. We guarantee at least 10 per cent.

ROBB ENGINEERING COMPANY, Ltd. AMHERST, NOVA SCOTIA.

HADFIELD'S STEEL FOUNDRY CO. LTD.

SOLE MAKERS OF MANGANESE STEEL

Under the Hadfield System and Patents.

- Tool Steel
- Mining . .
- Drill
- Steel. . . .
- Hammers
- Shovels, .
- Picks, . . .
- Wedges, .
- Steel
- Forgings,
- Etc., Etc.

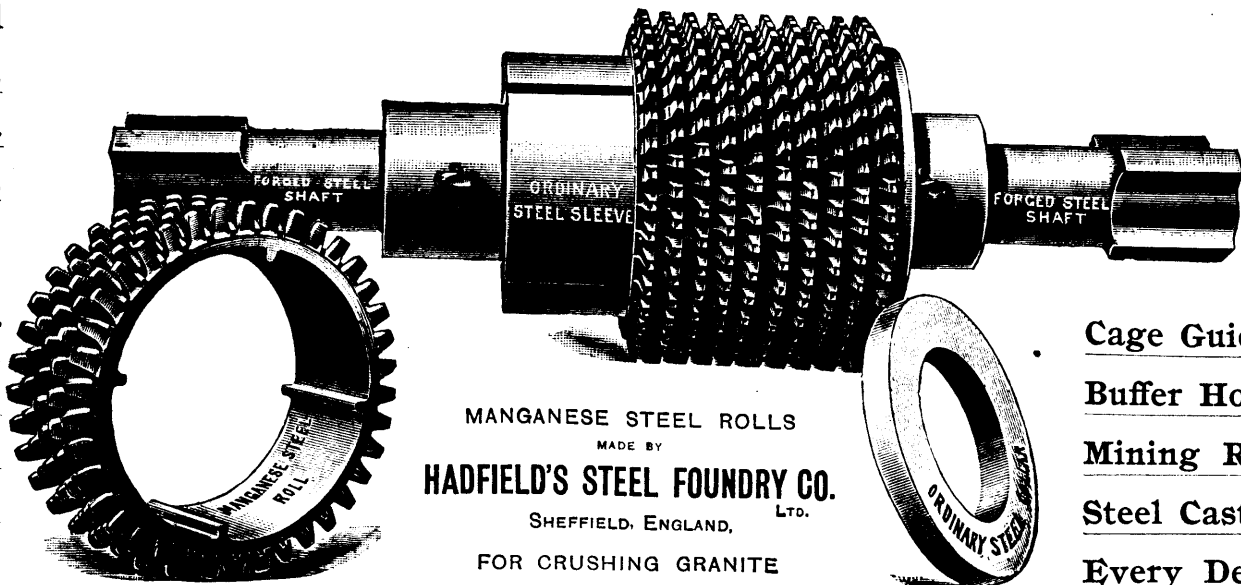

- Rollers, .
- Pulleys, .
- Trolley . .
- Wheels, .
- Pedestals
- Cage Guides,
- Buffer Hoops,
- Mining Requisites,
- Steel Castings of . .
- Every Description.

SOLE MAKERS OF Hadfield's Patent

"HECLA" CHROME STEEL SHOES AND DIES.

HECLA WORKS:

Sheffield, England.