

Technical and Bibliographic Notes / Notes techniques et bibliographiques

The Institute has attempted to obtain the best original copy available for filming. Features of this copy which may be bibliographically unique, which may alter any of the images in the reproduction, or which may significantly change the usual method of filming, are checked below.

L'Institut a microfilmé le meilleur exemplaire qu'il lui a été possible de se procurer. Les détails de cet exemplaire qui sont peut-être uniques du point de vue bibliographique, qui peuvent modifier une image reproduite, ou qui peuvent exiger une modification dans la méthode normale de filmage sont indiqués ci-dessous.

- Coloured covers/  
Couverture de couleur
- Covers damaged/  
Couverture endommagée
- Covers restored and/or laminated/  
Couverture restaurée et/ou pelliculée
- Cover title missing/  
Le titre de couverture manque
- Coloured maps/  
Cartes géographiques en couleur
- Coloured ink (i.e. other than blue or black)/  
Encre de couleur (i.e. autre que bleue ou noire)
- Coloured plates and/or illustrations/  
Planches et/ou illustrations en couleur
- Bound with other material/  
Relié avec d'autres documents
- Tight binding may cause shadows or distortion along interior margin/  
La reliure serrée peut causer de l'ombre ou de la distorsion le long de la marge intérieure
- Blank leaves added during restoration may appear within the text. Whenever possible, these have been omitted from filming/  
Il se peut que certaines pages blanches ajoutées lors d'une restauration apparaissent dans le texte, mais, lorsque cela était possible, ces pages n'ont pas été filmées.
- Additional comments:/  
Commentaires supplémentaires:

- Coloured pages/  
Pages de couleur
- Pages damaged/  
Pages endommagées
- Pages restored and/or laminated/  
Pages restaurées et/ou pelliculées.
- Pages discoloured, stained or foxed/  
Pages décolorées, tachetées ou piquées
- Pages detached/  
Pages détachées
- Showthrough/  
Transparence
- Quality of print varies/  
Qualité inégale de l'impression
- Continuous pagination/  
Pagination continue
- Includes index(es)/  
Comprend un (des) index
- Title on header taken from:/  
Le titre de l'en-tête provient:
- Title page of issue/  
Page de titre de la livraison
- Caption of issue/  
Titre de départ de la livraison
- Masthead/  
Générique (périodiques) de la livraison

This item is filmed at the reduction ratio checked below/  
Ce document est filmé au taux de réduction indiqué ci-dessous.

10X	12X	14X	16X	18X	20X	22X	24X	26X	28X	30X	32X
								✓			

# THE CANADIAN MANUFACTURER

DEVOTED TO  
 THE MANUFACTURING & MINING INDUSTRIES,  
 OF THE DOMINION.

# AND INDUSTRIAL WORLD.

Vol. 14.

TORONTO, JANUARY 6, 1888.

No. 1.

Established  
1856.

The J. C. McLAREN BELTING CO. Successors to the  
Late J. C. McLAREN.

## CARD CLOTHING

Set in Leather, Cotton, Natural Rubber, Backing in Iron, and Patent Tempered Steel Wire.

SOLE AGENTS FOR THE DOMINION,

SYKES' PATENT NEEDLE POINTED CARDS.

292 & 294 ST. JAMES STREET, MONTREAL.

Now is the time to place orders for early spring delivery.

"Old Dyewood Warehouse"

Established 1820

Theo. H. Eaton & Son,

Windsor, Ont. : Detroit, Mich.

IMPORTERS OF

ANILINE COLORS,

DYE WOODS,

DYEING DRUGS, CHEMICALS, Etc.

MANUFACTURERS OF

GLAUBER SALTS AND EXTRACT INDIGO.

SOLE AGENTS IN THE UNITED STATES AND CANADA  
FOR THE "CROWN ANILINE DYES."

THE

Gutta Percha & Rubber

MANUFACTURING COMPANY,  
OF TORONTO.

WAREHOUSE

YONGE STREET, TORONTO.

The largest manufacturers in the world of  
Vulcanized India Rubber Goods for mechanical  
purposes.

Rubber Belting from 1 to 72 inches wide.

Hose, for conducting, suction and steam.

Packing, Cloth Insertion and pure.

Tubing, of all kinds.

Rubber, Linen, and Cotton Fire Hose.

Maltese Cross Carbolized Fire Hose.

A full Stock always on hand.

Write for Price Lists and Discounts.

W. R. BROCK & CO.

IMPORTERS OF

General Dry Goods

TORONTO.

We are prepared to pay "SPOT CASH" for  
clearing lines of Canadian Manufactures.

These lines we offer to our customers at a  
small advance

We make a specialty in the following :

Canadian Tweeds, Blankets, Flannels,  
Yarns and Knitted Goods.

CANADIAN COTTONS.

W. R. BROCK & CO.

Imperial Bank of Canada.

Head Office - Toronto.

H. S. HOWLAND, President. T. R. MERRITT, Vice-President.  
D. R. WILKIE, Cashier.

Capital Paid-up - \$1,500,000  
Reserve - \$550,000

Purchases Municipal Debentures.  
Issues Drafts on its Branches and Agencies in the  
North-West.

Transfers Moneys by Telegram to Winnipeg and  
Brandon.

Agents in London,  
LLOYD, BARNETT & BOSANQUET'S BANK  
(Limited).

62 LOMBARD STREET,  
with whom moneys for transmission from Great Britain to  
Ontario and the North-West may be deposited.

A general Banking Business transacted.

John Bertram & Sons,

CANADA TOOL WORKS !

Dundas, Ont.

SEE ADVERTISEMENT, PAGE 28.

J. C. DIXON & BROS.

WORSTED SPINNERS,

DUNDAS, Ont.

MANUFACTURERS OF  
FINGERING, KNITTING,  
and all descriptions of  
WORSTED YARNS.

## PATENTS

PROCURED In Canada, the United States and all foreign countries, Caveats, Trade-Marks, Copyrights, Assignments, and all Documents relating to Patents, prepared on the shortest notice. All information pertaining to Patents cheerfully given on application. ENGINEERS, Patent Attorneys, and Experts in all Patent Causes.

DONALD C. RIDDOUT

ESTABLISHED 1867  
22 KING STREET  
TORONTO & CO.

**The Canadian Bank of Commerce.**

HEAD OFFICE, TORONTO.

Paid up Capital, \$6,000,000.  
Reserve, 500,000.

**DIRECTORS.**

HENRY W. DARLING, Esq., President.  
GEORGE A. COX, Esq., Vice-President.  
Jas. Craith, Esq., W. B. Hamilton, Esq.,  
Wm. Gooderham, Esq., John I. Davidson, Esq.,  
Matthew Leggat, Esq., George Taylor, Esq.,  
Hon. Wm. McMurter, Hon. S. C. Wood,  
B. E. WALKER, GENERAL MANAGER.  
J. H. PLUMMER, ASST. GEN. MANAGER.  
WILLIAM GRAY, INSPECTOR.

New York—J. H. Goodby & Alex. Laird, Agents.  
BRANCHES

Ayr	Quebec	St. Catharines,
Barrie	Hamilton	Sarnia,
Hellville	Jarvis	Seaford,
Berlin	London	Simcoe,
Bienheim	Montreal	Stratford,
Brimford	Norwich	Strathroy,
Chatham	Orangeville	The Old,
Collingwood	Ottawa	Toronto,
Dundas	Parkhill	Walkerton,
Dunville	Paris	Windsor,
Galt	Peterboro	Woodstock.
Goderich		

Commercial credits issued for use in Europe, the East and West Indies, China, Japan and South America.

Sterling and American Exchange bought and sold. Collections made on the most favorable terms. Interest allowed on deposits.

**BANKERS.**

New York—The American Exchange National Bank.  
Chicago—American Exchange National Bank.  
London, England—The Bank of Scotland.

Largest Manufacturers of STEEL and BRASS STAMPS in Canada.

**PRITCHARD & ANDREWS**

OTTAWA, ONTARIO.

Rubber Stamps, Stencils, Seals, &c.

SEND FOR PRICES.

**DOMINION DYEWOOD & CHEMICAL CO.**

SOLE MANUFACTURERS OF

The Celebrated Yorkshire Scouring and Fulling Soaps, Neutral Cotton Seed Oil Soaps, Pure Lard Oils specially adapted for the Woollen Trade.

IMPORTERS OF

Indigo, Cochineal, Cudbear,  
Indigo Ext., Cutch, Archil,  
Madder, Dye woods,  
Dye-wood Extracts and all Dyeing Drugs,

ANILINE DYES, ALL COLORS.

SPECIALTIES ARE

Imperial Blue, Fast Seal Brown,  
Fast Acid Brown, Brilliant Scarlets,  
Azo Green, Fast Cardinals,  
Fast Acid Garnet.

Office: 77 FRONT ST. E. TORONTO. Works: Don Station.

**McARTHUR, CORNEILLE & CO.**

(SUCCESSORS TO JOHN McARTHUR & SON)

310 to 316 St. Paul Street,

and

147 to 151 Commissioners Street,

MONTREAL,

offer at closest prices

PURE OLIVE OIL.

WINTER-PRESSED LARD OIL,

EXTRA FINE SPINDLE OIL,

and a full assortment of other

LUBRICATING OILS.

Also

CHEMICALS,

DYESTUFFS,

DYEWOODS,

EXTRACTS,

&c. &c. &c.

Are Sole Agents in Canada for

SOCIETE ANONYME

DES

MATIERES COLORANTES ET

PRODUITS CHIMIQUES,

DE ST. DENIS,

Successors to

A. POIRKIER AND G. D'ALSACE.

PARIS,

Manufacturers of

ANILINE DYES,

ARCHIL

CUDBEAR.

&c. &c. &c.

Prize Medal, London Universal Exhibition, 1862.

Gold Medal, Paris Universal Exhibition, 1867.

Grand Diploma of Honor, Vienna Universal Exhibition, 1873.

Medal and Diploma, with Highest Commendations, Philadelphia Centennial Exhibition, 1876.

Maintain largest stock, replete with all the new and improved colors. Will be pleased to furnish quotations with samples and directions for use.

**D. MORRICE, SONS & CO.**

Manufacturers' Agents,

MONTREAL & TORONTO.

HOEHELAGE COTTONS.

Brown Cottons and Sheetings, Bleached Sheetings, Canton Flannels, Yarns, Etc., Ducks, etc.

ST. OROUX COTTON MILL.

Ticking, Denims, Apron, Checks, Fine Fancy Checks, Glaghams, Wide Sheetings, Fine Brown Cottons, etc.

ST. ANNE SPINNING CO. (Hoechelage.)

Heavy Brown Cottons and sheetings.

Tussah, Kilted goods, Flannels, Shawls, Woolen Yarns, Blankets, etc.

The Wholesale Trade only Supplied.

**New York Dyewood, Extract and Chemical Co.**

MANUFACTURE HIGH GRADE

CURED CHIP LOGWOOD

FOR WOOL DYEING.

OFFICE:

55 BEEKMAN ST., N.Y.

WORKS, BROOKLYN.

**MIDDLETON & M'REDITH, MONTREAL.**

CHEMICALS AND DYE STUFFS.

Sul Soda, Soda Ash, Bleaching Powder, Caustic Soda, Bi-Carb. Soda, Chlorate of Potash, etc., etc.

Extracts Indigo, Sarsaparilla, Fustic, etc., Gambier, Cutch, Sumac, etc., Acids.

ANILINE DYES,

Brooke, Simpson & Spiller's. Full Assortment on hand.

PHOSPHOR BRONZE, SILICATE CLOTH.

**PILLOW, HERSEY & CO.,**

Manufacturers of every description of Cut Nails, Tacks, Brads, Railway and Pressed Spikes, Horse Shoes, Carriage Tire and other Belts, Conch Screws, Hot Pressed and Forged Nuts, Felloe Plates, Lining and Saddle Nails, Tuiting Buttons, &c., &c.

The Hardware Trade, Shoe and Leather Finding Dealers, and Boot and Shoe Manufacturers, will find the Largest and Best Assortment and Greatest Variety of above Goods always in stock, and can rely on orders being rapidly executed, our facilities for doing so being unequalled.

Office, 91 St. Peter St. Montreal.

**DOMINION Card Clothing Works, York St., Dundas.**

**W. R. GRAY & SONS, PROPRIETORS.**

MANUFACTURE EVERY DESCRIPTION OF

Card Clothing and Woolen Mill Supplies.

This Space for sale.

This Space for sale.

This Space for sale.

This Space for sale.

# The Canadian Manufacturer.

Published on the first and third Friday of each month, by the  
CANADIAN MANUFACTURER PUBLISHING Co., (Limited).

6 WELLINGTON STREET WEST, - - - TORONTO.

ANNUAL SUBSCRIPTION, in Advance \$2.00

ADVERTISING RATES SENT ON APPLICATION.

FREDERIC NICHOLLS, *Editor.*

J. J. CASSIDEY, *Managing Editor.*

ED. D. McCORMICK, *Secretary.*

This Journal has won for itself an acknowledged position amongst Trade Journals and is recognized as the representative industrial paper of Canada. All the various industries of the country are represented in its columns, and it has been for years the fearless and consistent advocate of those reforms which were indispensable to the success of the Manufacturers. It now reaches nearly every mill and factory in the Dominion, and its influence is constantly increasing.

As a medium for advertisements of machinery, steam appliances, mill and factory supplies, etc., it is unequalled, and our rates will be furnished on application.

Communications from Manufacturers, Exporters, and others, are respectfully invited.

Any association of manufacturers who may desire to hold meetings for organization or other purposes, are invited to avail themselves of the meeting room adjoining the office of the CANADIAN MANUFACTURER.

MR. FREDERIC NICHOLLS is Secretary of  
The Canadian Manufacturers' Association,  
The Woolen Manufacturers' Association, and  
The Tanners' Association.

His Office is at the Publication Office of  
THE CANADIAN MANUFACTURER,  
6 Wellington Street West, Toronto.

## GREETING.

To every Canadian we wish individual prosperity and that they may long live to watch the progress of our national greatness. How is it some are more apt to observe with admiration the advancement of other countries than our own, although, comparatively speaking, there is no country on the face of the earth that has surmounted so many difficulties with so much credit as this Canada of ours? We ask every reader of this paper if he does not experience a feeling of pardonable pride, a touch of honest egotism, when he thinks or reads of the achievements our hardy and fearless forefathers, the pioneers of history, supplemented by the perseverance and enthusiastic enterprise of our agricultural, industrial and commercial community of later days. It has been these, our countrymen, who have transformed a literal howling wilderness, "a few arpens of snow," into a country which is the pride of every dweller within its bounds, a nation of but five millions—but such a five millions!

Our national credit ranks with the highest in the money markets of the world; our artificial waterways and railways respectively are marvels of engineering skill and national pluck; our public school system is renowned as far as the outermost confines of civilization; our farmers are intelligent, frugal and prosperous; our commerce stands upon a sure foundation and is honorably conducted, and our manufacturers are "still achieving, still pursuing," until phenomenal as their success has been, it has been but the measure of the success of all classes.

It was John Quincy Adams who once said: "The great interests of our agricultural, commercial and manufacturing nation are so linked in union together that no permanent cause of prosperity to one of them can operate without extending its influence to the others." This sentiment is as applicable to the Canada of to-day as it was to the American Republic when voiced by the lips of the President of the United States. Let us, believing in the truth of this sentiment, endeavor to live up to it! Let us, whilst striving after individual success not forget our patriotism.

We have a country to be proud of; we have conquered the wilderness; we have met and vanquished with chivalric spirit enemies from without and within; we have gained dignity as a nation and we have earned respect as a people. That each and every Canadian may strive to add lustre to the shield of our united Provinces and work in harmony for Canadian preferment, is our best and truest wish for the new year.

## CONVICT LABOR.

HIS HONOR JAMES SHAW SINCLAIR, Esquire, Judge of the county of Wentworth, at his court recently held in Hamilton, received a presentment from the grand jury in which they said:—

\* \* The inmates of the jail were surrounded by comforts which the honest poor of the county cannot always secure. If convict labor is objectionable, it appears to the grand jury that convict idleness is much more so, and it seems to the grand jury to be a singular substitute for penal servitude. The grand jurors believe that punishment for crime, if intended as a deterrent, must be effectual, and if convicts were compelled to labor, and labor hard, it might happen that, when restored to society, the habit would stick to them, and thus effect a permanent reformation.

In addressing the grand jury in reply to their presentment, the Judge spoke very strongly on that part referring to this subject. He said he had often thought it strange that some arrangement had not been made whereby prisoners might be kept at work, and hard work, as a punishment for the offences they had committed against the public. Sending a man to jail is no punishment. If the prisoners were made to work, and thus earn enough to pay for their keep, it would be a good thing. At present the respectable and law-abiding citizens are taxed to pay for the keeping of the prisoners in idleness. They should be made to work, by way of making restitution for the offences they had committed against society. In many States of the Union such had been tried, and with success, too, until the labor organizations brought influence to bear against the prison contract system. While the system was in vogue, Sing Sing was a self-supporting institution, but now there is a heavy deficiency. He thought the County Council should do something to provide some means for enabling and making prisoners to earn something.

In the issue of this journal of October 21st last we took occasion to comment upon the remarks of the Hon. Justice Armour, made at the Brantford Fall Assizes, regarding prison labor, His Lordship speaking in much the same strain as did Judge Sinclair.

These gentlemen are no doubt very learned in the law, and their rulings upon law points go unquestioned, but the misfortune with them is, that they do not mix enough with the common people—the non-professional classes—the tax-paying masses of whom they speak—and thus keep themselves fully advised of the views and sentiments of those who not only have the power to prevent convict labor being brought into disastrous competition with free labor, but the power also to make and unmake even judges.

No doubt it is very desirable that penal institutions should be self-supporting, and that the convicts should "earn enough to pay for their keep," as Judge Sinclair states it, but public sentiment is against the employment of convict labor when it is brought into competition with free labor. Bad men, as Judge Sinclair knows full well, are not imprisoned that they may be made to make restitution for offences committed against society; and law-abiding citizens are taxed to pay for their keep the same as they are taxed to pay salaries to judges and court officers; to maintain public highways, etc. Their support is a necessary burden which must be borne.

Judge Sinclair alludes to the fact that in many of the States of the American Union farming out prison labor has been successfully tried, and that the system would not have been abandoned if it had not been for the influence brought to bear against it by the labor organizations. He says that while the system was in vogue in Sing Sing prison, that was a self-supporting institution, but now there is a heavy deficiency. If the abolition of the system of farming out the convicts in the penal institutions of New York and other States was brought about through the influence of labor organizations, these organizations have brought about a condition of things for which they deserve the thanks of every honest man in the country. For years and years one stove manufacturing concern doing business in Albany had all the able-bodied convicts in Sing Sing prison engaged in the manufacture of stove hollow-ware, during all of which time it was impossible for any manufacturer in that section of the country to engage in the production of that special line of goods. And this monopoly—for it was a monopoly of the worst kind—had absolute control of the market, and the thousands of moulders and foundrymen who might have found employment in making non-convict stove hollow-ware, were forced to find occupation at other things. If we are not misinformed, all or most of the able-bodied convicts in the Indiana penitentiaries to-day are employed under contract in the manufacture of this same line of goods—stove hollow-ware—the system making it impossible for any stove foundry in the Western or Southern States to engage in the production of such goods. It has been stated that until the recent abrogation of the contract system in the New York prisons, probably nine-tenths of all the stove hollow-ware and cast iron cooking utensils in use in the United States was the product of convict labor—to what extent this is the fact in Canada also we are not at present prepared to say. But this we can say, and we commend the fact to the attention of our Canadian judiciary who so vehemently urge the employment of prison labor in our manufacturing industries, that until the Dominion Government made it a punishable offence for any one to import prison-made goods into Canada, this country was

being deluged from the United States with the products of prison labor.

Our judges are judges of the law, but they are not sole judges of the necessities which demand our laws. The people are the judges of these, and when our judges know that the people refuse to countenance any system by which prison labor is brought into competition with free labor, we think they are stepping outside the bounds of propriety in adversely commenting upon the laws on this subject, as some of them do.

#### BINDING TWINE

RECENTLY the *Toronto Globe* published a letter signed "Thomas McDonald," and headed "The Binding Twine Robbery," in which it was stated that the farmers of Canada were robbed of from \$150,000 to \$200,000 during 1887 by having been forced to buy an inferior article of home-made twine. The writer stated that in 1886 he could buy binder twine in the United States at seven cents per pound, while the price in Canada was ten cents for the same quality. At the time of the publication of this letter the *Globe* printed an editorial on the subject, sustaining the conclusions of Mr. McDonald that the duty on binding twine imposed an unjust and onerous tax on Canadian farmers.

A few days later the *Globe* printed a letter written by Messrs. A. W. Morris & Bro., proprietors of the J. A. Converse Manufacturing Company, of Montreal, amongst the largest manufacturers of cordage in Canada, in which the facts, as stated by Mr. McDonald, were denied in toto, and his and the *Globe's* conclusions upset. They show that the twine which could have been bought in the United States at seven cents a pound was of the same description as was being sold in Montreal at the same time at seven and one-sixteenth cents a pound, and that this twine was sisal, and not manilla; that manilla hemp was from three to three and a-half cents a pound higher in New York and Boston at that time than sisal hemp; that the net price in Montreal in 1886 for mixed twine, containing fifty per cent. of manilla hemp, was eight and ninth cents a pound, which was at least twenty per cent. lower than what the same quality of twine could be bought for in the United States for home consumption, and that in 1887 the Montreal price was but nine and four-fifth cents a pound.

Messrs. Morris summarize the case by making the following statements, which, they say, can be easily corroborated. They claim:—

1st. That during 1885, 1886 and 1887 the average price of binder twine was lower in Canada than in the United States for home consumption. 2nd. That the average quality of Canadian twine during that period was equal and this year superior to American. 3rd. That the average quality of the machinery now in operation in Canada is more modern and of a higher standard than that used in the United States. 4th. That the present factories engaged in this industry, if run to their full capacity, can meet the Canadian demand for binder twine twice over.

Canadian twine manufacturers have no fear of competition either in or out of the country so long as their foreign opponents are placed and kept upon a no superior footing with themselves.

The question of the alleged overvaluation by Customs officers of foreign-made binding twine imported into Canada, has

been discussed in the press for more than a year, Mr. McDonald having an application before the Customs Department, at Ottawa, setting forth his grievance in that regard. But a few days ago—last week—Mr. Bowell stated that he had received a note from Mr. McDonald, dated December 22nd last, in which he had transmitted to the Department an affidavit made in New York in reference to the value of the twine regarding which the dispute arose. Mr. Bowell says that this is the evidence Mr. McDonald was asked to produce over a year ago, and that the reason why Mr. McDonald's complaints had not before been investigated was because of Mr. McDonald's neglect in producing the evidence required.

#### A WRONG CONCLUSION.

MR. ERASTUS WIMAN, in "Commercial Union Document No. 9," entitled "The Perfect Development of Canada," a speech recently delivered by him at St. Thomas, Ont., quotes from Mr. Adam Smith as follows:

"To prohibit a great people from making all they can of every part of their own produce, or from employing their stock and industry in the way that they may consider most advantageous to themselves, is a manifest violation of the most sacred rights of mankind."

The greater includes the less, and to prohibit an individual citizen "from employing his industry" in any way he pleases, must consequently be a "manifest violation" of his most sacred rights. If this prohibition bears heavily upon the citizen, or even "a great people," is it necessarily unjust, as Mr. Wiman suggests? No citizen possesses any unlimited and unrestricted right to do as he pleases either with himself or his property, for both he and it are subject at all times to the superior necessities of the State. A man may not wantonly destroy either his own life or his property, and the State will prevent his doing so, although he may consider that what he proposes is "most advantageous" to himself. So, too, the "great people" of a State may be restrained "from employing their stock and industry" in the direction of free trade, for instance, if it is deemed better for the whole interests of the State thus to restrain. Great Britain herself, that beau ideal of "free trade," does not practice free trade absolutely, for there are quite a number of articles of commerce upon which she levies impost, or tariff duties, and from which a considerable portion of her revenues are derived. The Ontario Government enacted a law that any county in the Province could avail itself of the provisions of the Scott Act and thus prevent traffic in intoxicating liquors, and in many of the counties this prohibition law is now enforced, but according to Mr. Adam Smith, and Mr. Erastus Wiman, the "great people" of these counties, or a portion of them, are prohibited from engaging in an industry that they consider would be "most advantageous" to themselves. The majority of the people of Great Britain do not consider it unjust that their Government imposes duties upon importations of spirits, wine, tobacco, etc.; and the majority of the people of the Scott Act counties of Ontario do not consider it unjust that the liquor traffic in them should be suppressed. So, too, the "great people" of the United States do not think it unjust that their Government imposes duties upon the manufactures of foreign countries, nor do the "great people" of Canada think it unjust that they, too, should have to bear a similar burden. It costs money to support the State, and the

accepted political motto of all statesmen is, "The greatest good to the greatest number," and per contra, "The least evil to the smallest number." In raising revenues for the support of the State, the people of Great Britain consider that an imposition of tariff duties upon imports is not the most advantageous method of raising revenues for the support of their Government, but on the other hand the people of Canada and the United States do thus believe. The people of Great Britain consider that it is best to raise their revenues generally by internal taxation—all trades and vocations are taxed—and the money comes out of the pockets of the masses; but in Canada and the United States the people consider it best to raise their revenues in other ways—largely by the imposition of tariff duties upon imports; and the question of "the most sacred rights of mankind" does not appear, for there is no "manifest violation" of them. And what may be said of the employment by the people of their "stock and industry" under the restrictions of Government, applies also to even the life of the citizen, for if the State requires the services of the citizen for military purposes, his personal liberty must be surrendered on demand, even if he is required to face an enemy and bare his breast to bullets.

Mr. Adam Smith makes a rhetorical flourish that sounds very pretty, which Mr. Wiman applauds, but his conclusions are drawn from wrong premises.

*Sic transit gloria Commercial Union.*

It is now sought to bring Tilsonburg, Ont., into line as a bonus-giver to impecunious manufacturers.

"MR. WIMAN does not happen to be the whole American people."—*Mr. Joseph Chamberlain in Ottawa.*

"IF Canada gives up the right of self taxation she ceases to be an independent country."—*Mr. Joseph Chamberlain, at Ottawa.*

"I DO not think there is the slightest possibility of Mr. Butterworth's bill passing Congress."—*Mr. Joseph Chamberlain, at Ottawa.*

"THE American Congress, in my opinion, have no more idea of passing Mr. Butterworth's bill than of flying."—*Mr. Joseph Chamberlain, at Ottawa.*

"I HAVE not met one single American in the States who thought Commercial Union possible except as a step to Annexation."—*Mr. Joseph Chamberlain, at Ottawa.*

"IT is not right to sweep away by legislative enactment industries which have been called into life and fostered by legislative action."—*Hon. John Macdonald, of Toronto, at the Boston banquet.*

"LET there be no strife between you and me, and between my herdmen and thy herdmen, for we be brethren."—*Holy Bible, as quoted by Senator Macdonald, of Toronto, at the Boston banquet.*

"WHILE I have the honor to occupy a seat in the Canadian Parliament, my voice shall always be lifted to preserve peace and prosperity between the nations of the United States and Canada."—*Hon. John Macdonald, at the Boston banquet.*

THE United States Signal Service Bureau now gives notice to the more important railroad lines of the country of approaching cold waves and big snow storms, and the timely warning enables the railroad officials to make necessary preparations.

OUR respected and veracious contemporary, the *Winnipeg Commercial*, says:—"Some 300,000 tons of Oregon flour will be taken from Vancouver by the next steamer for China." The next steamer sailing for China from Vancouver must be a whopper. We hope she won't be overloaded.

"I REALLY do not know that the Birmingham Chamber of Commerce is a very important body. \* \* The proposition for Commercial Union, as I understand it, comes from Mr. Wiman, but he may be like the Birmingham Chamber of Commerce."—*Mr. Joseph Chamberlain, at Ottawa.*

"Is it possible that Canada would give up all control of her tariff and allow it to be fixed at Washington? If that is to be a result of Commercial Union, Canada would be giving up her independence, as the characteristic of independence is the right of self-taxation."—*Mr. Joseph Chamberlain, at Ottawa.*

WHEN Mr. Chamberlain was in New York, before going to Washington, Mr. Erastus Wiman wrote him a note saying that if he was granted an interview of an hour's duration he would fully acquaint him with the sentiments of Canada anent the Commercial Union question. Has Mr. Wiman read Mr. Chamberlain's reply from Ottawa?

THE *Globe* informs its readers that a bumblebee has been discovered in Borneo with a stinger an inch long. Commercial Union got a bumblebee in its pants the other day with a stinger several inches long when Mr. Chamberlain expressed himself on the subject in Ottawa. Mr. Wiman thinks that the Chamberlain bumblebee has a stinger a mile long.

A BANGOR, Maine, lumber company recently filled an order for a lot of hardwood flooring to go to Australia. It is probable that the timber of which this flooring was made was grown in Canada, and we mention the incident for the purpose of asking why Canadian millmen and lumbermen do not seek an outlet for this class of their products in the Australian Colonies?

"You have to take three important steps before you could carry Commercial Union through. First, you must have your plan and let other people know what it is. Second, you must prove that a majority of the people of Canada want it; and third, you must prove that a majority of the people of the United States want it."—*Mr. Joseph Chamberlain, at Ottawa.*

No English newspaper of any standing, except the *Spectator*, gives Commercial Unionists any sort of comfort.—*Toronto Mail.* Commercial Union will involve the imposition of a

common tariff against the rest of the world, quite as high as we now have, possibly a little higher.—*Halifax Chronicle.* As the boys say on 'Change, Commercial Union has a very black eye.

"WE are proud of the glory of Great Britain, and we should do nothing that would make that glory pale. As patriotic subjects of Great Britain we should do nothing that would act as an entering wedge to annexation to the United States and the severance of our political relations with Great Britain."—*Patriot John Macdonald, of Canada, at the Boston banquet.*

M. D. BABCOCK, inventor of the Babcock fire extinguishing apparatus, died in a San Francisco almshouse a few days ago, aged 70 years. At one time he was in receipt of \$10,000 a month for royalty on his machines, but after selling the patent rights his money was soon spent, and for some years he wandered about in a destitute condition. He was admitted to the almshouse about six years ago.

A REPRESENTATIVE of this paper was one of the journalists who recently interviewed Mr. Joseph Chamberlain, at Ottawa. We publish some of the *morceau* that fell from the tongue of the distinguished gentleman on that occasion. Mr. Chamberlain is a man of considerable weight, and his emphatic sitting-down on the Commercial Union fad and some of its advocates produced a sickening, dull, heavy thud.

MR. CHARLES BOECKH, senior, of Messrs. Charles Boeckh & Sons, Toronto, manufacturers of brushes, brooms, etc., has suddenly been called to his old home in Strasburg, Germany, by the death of his brother. These gentlemen have been connected with an extensive brush manufacturing establishment in Strasburg for many years, and Mr. Boeckh returns there to look after the interests of the business.

PRESIDENT CLEVELAND has received an invitation from the British Government to have the United States participate in the forthcoming international exhibition to be held in Melbourne, Australia, this year, to celebrate the centenary of the founding of New South Wales. Secretary Bayard recommends that the invitation be accepted, and the sum of \$50,000 be appropriated to defray the expenses of a commission to represent the United States at the exposition.

A TRAIN-LOAD of twenty-two cars of dressed turkeys was recently sent from Ottawa to Boston for shipment to England for the Christmas holiday market. The weight of the poultry was over 220 tons, and its value more than \$40,000. The shipment arrived in London in good condition and commanded the highest market prices, selling at from twenty to twenty-five cents per pound. This is probably the beginning of a new and valuable branch of trade between Canada and Britain.

THE *Philadelphia Record* says that coal sold for \$3.50 per ton in that city in 1853, while in 1887 coal from the same hills sold for \$5.75 per ton, the excess of \$2.25 per ton being levied in the interest of protection through the tariff of 75 cents a ton on coal. This is like much other free trade argu-



ment. If the 75 cents duty was added to the 1853 price of \$3.50 per ton it would be but \$4.25, and whatever may be said against the coal companies, it is silly nonsense to charge the difference to the tariff.

MR. THOMAS McAVITY, head of the firm of T. McAvity & Sons, St. John, N.B., manufacturers of steam fitters' supplies, brass goods, etc., died in that city December 13th last, aged 78 years. Mr. McAvity was a native of Ireland, and was carried to St. John when a child, where he lived until his death. In 1835 he engaged in the hardware business, which was subsequently expanded so as to embrace manufacturing. He held many positions of trust and honor. While he lived he was loved and respected, and his death was mourned by the whole community.

At the recent dinner of the New York Board of Trade, Mayor Hewett, of that city, attacked the Knights of Labor fiercely, declaring that the cabals that ordered strikes were worse than burglars or highwaymen. He prophesied a conflict and believed if the matter is not settled speedily the next division of parties in the United States would not be on the tariff but on the question of law and order as opposed to secret cabals. If the so-called labor organizations were not checked he foresaw that the door would be opened to a condition of violence such as has not been known since the Middle Ages.

MESSRS. HARPER & WEBSTER, Shediac, N.B., manufacturers of boots and shoes, write us as follows regarding our efforts to protect the interests of Canadian manufacturers:—"We are glad to notice that you have seized the Commercial Union fad by the throat, and hope you will not slacken your grip until you have strangled the vampire. If you vanquish the boomsters in the west we will care for them down here by the sea. Indeed, we do not know of but one man in this county who does the fad any honor, and he prefers political union. We hope you will continue to make it hot for the irreconcilables and enemies of our common country."

THE tender recently made by Messrs. Anderson, Anderson & Co., London, Eng., for the Canadian transatlantic mail service stipulates for the employment of a line of first-class steamers which will be 525 feet long, 54 feet breadth of beam and 39 feet deep,—about 7,000 tons. The speed guaranteed will be 20 knots an hour, obtained from engines of 13,000 horse power. The projectors of the line allege that by coming to Quebec or Montreal in summer, and Halifax in winter, passengers can be landed in Chicago by the time they would reach New York by the present lines. They are confident that the whole passenger traffic will be revolutionized, and it is contended that when the Sault Ste. Marie road is running passengers could be landed in St. Paul and Duluth *via* this line of steamers before passengers by the other lines could reach New York.

THERE are some twenty-four vapor stove manufacturers in the United States, who, during the season of 1887, sold over 104,000 vapor stoves. The use of this article in that country is extending and enlarging very rapidly. We have knowledge

of one concern who began the manufacture of vapor stoves in 1882, their output being less than a thousand stoves in that year, who made seven thousand of them in 1883, over thirteen thousand in 1886, and twenty thousand in 1887. The insurance companies did all they could to prevent their use, but now they have submitted to the inevitable. Insurance companies in the United States now accept fire risks where vapor-stoves are used, the only stipulations regarding them being of a common-sense character which no one objects to.

MR. F. B. THURBER, of New York, has made a big fortune manufacturing and selling oleomargarine, sometimes called "bull butter." The importation of oleomargarine into Canada is prohibited by law. Mr. Thurber is a friend of Mr. Erastus Wiman, and longs for Commercial Union. He might then have his market for oleomargarine "expanded" so as to include some five million Canadian consumers. Mr. Thurber is offended because Mr. Joseph Chamberlain, at Ottawa, said that Mr. Wiman didn't represent anybody but himself either in the United States or Canada. He has written a letter to the New York *Herald* in which he says that Mr. Wiman "enjoys the respect of all who know him." No doubt. Mr. Chamberlain should have said that Mr. Wiman represents both himself, Mr. Butterworth, Professor Smith and Mr. Oleomargarine Thurber.

BRANTFORD, Ont., has passed a by-law giving to a private company recently organized there the exclusive privilege of boring for natural gas within the city limits, and of piping the gas through the streets to points of consumption. This is a new feature and advanced ground in the bonusing business, with which Brantford and some other Ontario towns are so seriously afflicted. Usually the enterprising (?) applicant for municipal favor is content to obtain money enough to start his business, but not selfish enough to try to keep every body else out; and the bonus-crazed towns have usually been complaisant and generous enough to give to all who ask; but in this instance the benefactors (?) of the community are voted the exclusive privilege of searching in the bowels of the earth for natural gas, and of piping it to consumers in case it is found. We wonder if a Brantfordite would be allowed to bore for gas in his own back yard, or use it if he found it?

THE timber limit sale by the Ontario Government last month realized prices far in advance of what was expected. The total sum realized for the privilege of cutting timber on the 450 square miles sold amounted to \$1,350,699, an average of over \$2,957 per square mile. This is in the face of the recent sharp increase of 50 per cent. in the annual ground rent, and 33½ per cent. in the timber dues. The first sale of pine timber lands under the auspices of the present Government took place in 1872. The area then disposed of was about 5,000 square miles. The total amount bid at the sale was \$592,601, or an average of little more than \$100 per square mile. Since 1872 every sale of timber limits has been carried out under the auspices of the present Commissioner of Crown lands. The area sold within these fourteen years is 2,907 square miles, for which the Government received \$1,160,000, an average rate of nearly \$400 a square mile.

It is claimed that Russian foreign trade has declined rapidly under the influence of a protective tariff, the decrease being over 20 per cent., both of exports and imports, in three years, but this year while the imports decrease the exports have increased.—*Hamilton Times*.

THE protective tariff is all right, and the "influence" of it is all right, too. What's the use of exporting large quantities of merchandise that can be used at home: and what's the use of importing large quantities of merchandise that can be manufactured at home? The imports decrease in volume not because such goods are not consumed at home, but because the home factories meet the home demand in large measure; and the exports increase in volume because the improvement in the condition of the people enables them to more than supply the home market.

THE *Hamilton Times*, speaking of the United States system of pensioning Union soldiers of the war of the rebellion, and the exceedingly large number of pensioners now being carried upon the rolls, says that, "whatever charge can be laid against the Cleveland administration, it cannot be said that it is neglecting the interests of those who participated in the civil war." The density of the ignorance which prompts such a statement is phenomenal. Probably the most conspicuous act of Mr. Cleveland's official life was the vetoing of several hundred pension bills in one batch, a greater number of vetoes than all his predecessors from Washington to Arthur had ever signed. His Bourbon proclivities, and sympathies with the element that precipitated the war has kept Mr. Cleveland's face set steadily against granting pensions to Union soldiers, and such pensions as have been granted during his administration were granted in spite of him.

MR. GOLDWIN SMITH, in a recently published letter, speaking of the set-back his Commercial Union party has received, says:—"Mr. Butterworth's sickness at the moment when he was bringing on his motion in Congress, is, it must be owned, a heavy blow to us." So? Mr. Butterworth may recover from his sickness, but it is not at all likely that Professor Smith's Commercial Union party will ever recover from the "heavy blow" under which it is now staggering. The cause must be frail and weak if its success depends upon favorable consideration in the United States Congress. Mr. Butterworth introduced his little bill there at the last session—about a year ago—but it received no consideration whatever, and there is no reason to suppose that it would meet with any better fate now. Perhaps Mr. Butterworth is glad for his own sake that he is too sick now to "bring on his motion." Probably when he recovers he will have changed his mind and not bring it at all. If there was anything in the scheme the illness or even the death of one man would not stand in the way of its introduction and discussion.

MENTION is made in our "Manufacturing" department of a concern doing business in Richmond, Va., who manufacture some 200,000 paper boxes a day, used mostly by druggists and physicians. They give employment to over 400 hands, mostly women and girls, who earn from \$3 to \$10 a week: and most of the paper boxes of this description consumed in Canada are

manufactured in this establishment. We do not think that there is any such concern doing business in this country. Dextrousness and nimbleness of fingers rather than technical skill are required in the manufacture of this class of goods, and there is abundance of such labor to be had in Canada. There can never be any monopoly in conducting such a business, for no patented machinery or process is required, and there is no country where the raw material—paper—is cheaper. The finer and more expensive grades of ornamental and decorated papers used in the Richinond factory are imported from Germany, and similar goods could be laid down in Canada quite as cheaply as in the United States. The establishment of such a factory in this country would be a remunerative investment no doubt.

MR. GOLDWIN SMITH weeps bitter tears over the fact that Mr. Benjamin Butterworth was taken down sick just at the moment when he was bringing on his Commercial Union with Canada motion in the United States Congress, and admits that the incident "is a heavy blow to us." "Having met him in the campaign I have been deeply impressed by his ability and power as a speaker," says the professor; who also remarks that Mr. Butterworth expressed to him "kindly feelings towards Old England, and strong reprobation at the insulting language held about her by certain members of Congress." Mr. Smith seems to have been badly "mashed" on the Cincinnati statesman; and no doubt Old England and all the sons of Old England, wherever they may be dispersed, will be duly and truly thankful that Mr. Butterworth not only entertains "kindly feelings" towards her, but actually "strongly reprobates the insulting language held about her" by certain other illustrious American statesman. Surely now the lion and the eagle shall lie down together, and Mr. Benny Butterworth shall lead them. The fact is, the professor has become a monomaniac on the fad. His mind is affected by it and his antics are unnatural. He is inclined to slobber and gush over his new-found acquaintances. For his sake we sincerely wish speedy recovery to health of his friend whom he "met in the campaign," Congressman Butterworth, of Cincinnati.

The United States surplus is a mighty argument against protection.—*Toronto Globe*.

It was under their protective tariff that the United States raised surpluses, and a surplus surely is a sign of prosperity. Most sensible people will therefore be inclined to think that the surplus is an argument in favor of protection.—*Brockville Times*.

And as the surplus has got to be something of a curse instead of a blessing, and a source of financial danger to the business interests of the country, our neighbors propose to get rid of it by getting rid of some of the protection, thus lightening the taxation borne by the people. From the American standpoint, therefore, the surplus is an argument against protection.—*Montreal Herald*.

As we before remarked, "The United States surplus is a mighty argument against the United States Internal Revenue system. Protection is all right." The trouble with our Grit contemporaries is that they seek to make it appear that the white elephant surplus in the United States treasury arises from the operations of the tariff alone, and then arguing that the only way to get rid of the surplus is only by getting rid of the tariff. The fact is, the Internal Revenue system

there converts nearly \$120,000,000 a year into the treasury, which amount is much greater than the yearly surplus complained of. Protection is all right, and the tariff is all right. Let our Yankee friends abolish their Internal Revenue system, and increase their tariff duties to meet what will then otherwise be a deficit.

MR. CLEVELAND'S appeal for the removal of duties upon wool was responded to promptly and unanimously by the woolen manufacturers and wool growers of the United States. The *Bulletin of the Textile Association* shows that in the three years before 1883 the revenue from duties upon woolen yarns and cloth was, in gross, \$3,558,366.42. In 1883, the duties were lowered, and, besides, such interpretation was given to the worsted clause as to lower them more than Congress intended. As a result, the duties on these articles for 1884, 1885 and 1886, amounted to \$10,126,793.54, a gain of \$6,568,427.12 to the public revenues as a consequence of the very kind of tariff reduction proposed by President Cleveland for the pretended purpose of cutting down the revenues of the government. A vigorous protest followed the publication of the President's message from the wool growers of the country, from New England to the Pacific. In Montpelier, Vermont, the State Grange adopted a resolution instructing its Executive Committee to request members of Congress from that State to oppose the passage of any bill that has for its object the removal of duties from wool and raw material, and to endeavor to secure such legislation as will protect the various interests of the farmers of Vermont, especially upon bark, lumber, wool and poultry. The Ohio State Grange passed resolutions opposing the placing of raw materials on the free list, protesting against any further reduction in the wool tariff, and demanding the restoration of the tariff of 1867; and prominent wool growers of California, in a called meeting in San Francisco, adopted resolutions condemning any effort for a reduction of the tariff on wool, and urging upon Congress the necessity of retaining the present rate of duty. The farmers of the United States understand their interests too well to take stock in the abolition of a tariff policy that makes it possible for them to make a living.

GRIP PUBLISHING Co., Toronto, have sent us "The Epistles of Airlie," a collection in book form of the "Airlie" letters which have appeared in *Grip*, during the last few years; and "Why I Joined the New Crusade," a plea for placing taxes on land values only, by R. T. Lancefield, an address recently delivered before the Anti-Poverty Society, of Toronto.

THE *Ohio Valley Manufacturer*, published weekly at Wheeling, W. Va., is a new advocate for the favor of the manufacturing world which we cordially welcome to our office. It is devoted to the "nail, iron, steel, glass, pottery, hardware and manufacturing industries of the Ohio Valley," and is a model of journalistic neatness and good taste. Mr. P. H. Moore, the editor, is an old and experienced newspaper man, entirely familiar with the requirements of the duties which he has undertaken.

THE Chinese are to have a new coinage, and ninety coining presses and all necessary machinery for fitting up a mint in China will be ready by next April. The presses, which are being made in England, are noiseless and automatic, and are capable of producing 2,700,000 coins per day of ten hours. The coins are to be dollar pieces and three subdivisions, a half, a fifth and a tenth in silver, as well as the "cash" or "mills," equal to one thousandth part of a dollar in rolled brass. The silver dollar is equal to 5s. in English money. Of the 2,700,000 coins which are to be struck per day, 100,000 are to be, if required, silver dollars. The extent of the order may be estimated from the fact that the Royal mint in Lon-

don is only furnished with sixteen presses. The daily value of their coinage in English money is £25,650.—*Banker's Monthly*.

THE readers of *Wide Awake* magazine for young people are so accustomed to good reading and pictures that they will wonder how it is going to be better than ever the coming year. But it is. The new year begun with the holiday number, larger and richer, more varied, and therefore better than ever before. The wonder is that such a library and picture-gallery can be got together for \$2.40 a year—a thousand pages and everything fresh and new—stories, history, travels, biography, sketches, anecdote adventure—and all instructive as well as entertaining. So high is the best of young people's literature nowadays that we are all of us glad to be young. Nine tenths of reading people prefer it to what is written for them, for it has the rare merit of being easy as well as good. We know of no gift more sure of bringing a happy response in a reading family. Send \$2.40 to D. Lothrop Company, Boston, Mass.

IT seems almost incredible to say that a library fairly representing approximately two thousand of the most eminent authors of the world, of all lands and all times, can really be placed within the reach of ordinary homes. Yet this is what is accomplished by Alden's *Cyclopedia of Universal Literature*, volume VIII of which was issued in November. The work, completed, is to comprise from fifteen to twenty volumes, which are in large type, and really beautiful and excellent in all mechanical qualities, and yet sold at the low price of 50 cents per volume for cloth, or 60 cents for half-morocco bindings, and even from these prices large reductions are made to early purchasers, and to clubs. The publisher will send a specimen volume to any one on receipt of the price, allowing the privilege of return if the set is not wanted. John B. Alden, publisher, 393 Pearl St., New York.

THE American Brake Co., St. Louis, Mo., have sent us their new catalogue and price list which is devoted entirely to the locomotive brakes manufactured by them. These brakes have been adopted by many of the largest railway systems on the continent, which is a testimony from the highest sources to their excellence. The catalogue, having reference exclusively to these brakes, is profusely illustrated, showing their construction and application, is intended for the study of those informed on the general subject of railroad equipment, and for a clear understanding of this system. The company invite correspondence. The book itself is gotten up in most excellent and convenient style, and reflects great credit upon both the compiler and the printer. Patents on these brakes were issued in Canada in November, 1885, October, 1886 and May, 1887, and these brakes are now in use on the Canadian Pacific, Intercolonial, Michigan Central, Chicago & Grand Trunk and other railroads operating in the Dominion.

THE *Empire*, the new daily Liberal-Conservative paper of this city, began publication last week, the weekly *Empire* following two days later. This paper starts under most favorable circumstances, its capital of \$250,000 being ample, and a guarantee of its financial soundness. The directorate and stock-holders, composed of the leading public and business men of Canada, are a powerful interest in its favor. The staff has been selected with the greatest care. David Creighton, Esq., M.P.P. is Managing Director, Mr. John Livingston is editor-in-chief, Mr. Louis P. Kribs, news and city editor, Mr. H. J. P. Good, sporting editor, Mr. J. B. McLean, commercial editor, Mr. Frank Krauss, M.A., night editor, while the staff of writers comprises such well known journalists as Messrs. E. J. Tooker, T. A. Gregg, A. H. U. Colquhoun, Herbert Burrows, J. B. Kerr, C. Dell Smith, P. F. Cronim, J. Brown, T. C. Ketchum and many others. The staff of correspondents includes representatives in all the cities, towns and districts of Canada, and the principal cities of England and the United States. The facilities of the *Empire* for the collection of news are not equalled now, and never have been equalled in Canada. The mechanical department is complete in every respect, with presses and apparatus of the latest make that surpass in all essentials the equipment of any other office in the Dominion. Each department of the paper is presided over by experienced and efficient men, whose efforts are supplemented by those of an able staff of assistants. Neither expense nor trouble is being spared to make the *Empire* superior, as a newspaper, to any of its Toronto contemporaries, and the public may rest assured that its appearance will mark a new era in progressive Canadian journalism. The building occupied by the Empire Company, known as Thomas' Ticonic Building, is in the rear of Manning Arcade, King street west. The premises include four stories and a basement of a new and spacious building. The press on which the paper is printed is a "Presto" web perfecting press manufactured specially for the *Empire* by Messrs. R. Hoe & Co., New York, the only one of the kind in the Dominion.

# F. E. DIXON & Co.

MANUFACTURERS OF

**Patent Lap-Joint, Star Rivet**

## Leather Belting

SOLE AGENTS FOR

### PHOENIX BELT OIL

*The Only Perfect Belt Dressing.*



**I**T will make the leather more durable.  
 It will effectually prevent the slipping of the belt.  
 It does not affect the cement which holds the laps together.  
 It does not increase the stretching of the belt and thus render it narrower.  
 It makes the leather perfectly water-proof. Belts dressed with this oil can be and are run in places where the temperature reaches 160 to 175 degrees, while in the other extreme, we have endorsements from owners who run their belts in ice houses. Indoors or out, in any kind of weather, wet or dry, hot or cold; belts thoroughly dressed with Phoenix Oil will always run satisfactorily.

SEND FOR PRICE LIST AND CIRCULARS,  
And our Latest Pamphlet on Belting.

# F. E. DIXON & CO.

70 KING STREET EAST.  
TO

NEW LEATHER BELTING FACTORY,  
11 JORDAN STREET.

---

Toronto, January, 1888.

*TO USERS OF BELTING.*

We take pleasure in introducing  
ourselves to you as makers of

**OAK TANNED LEATHER BELTING.**

We have our new Factory in operation,  
and shall be pleased to forward you  
samples and prices upon application.

Very respectfully yours,

**GEO. F. HAWORTH & CO.**

# Manufacturing.

*This department of the "Canadian Manufacturer" is considered of special value to our readers because of the information contained therein. With a view to sustaining its interesting features, friends are invited to contribute any items of information coming to their knowledge regarding any Canadian manufacturing enterprises. Be concise and explicit. State facts clearly, giving correct name and address of person or firm alluded to, and nature of business.*

MR. WM. WHALLEY, Mersea, Ont., is erecting a lumber mill at that place.

MR. T. G. MITCHELL, Watford, Ont., will erect a 25,000-bushel grain elevator.

MR. WM. ASSELSTINE, Roblin, near Napanee, Ont., is building a new shingle mill.

MR. JAMES MAHAFFY, Port Albert, Ont., has nearly completed his new roller mill.

MR. ANTHONY GOETTLE, Seabringville, Ont., will put roller machinery into his flouring mill.

MESSRS. KENNEDY & BUNSTON, Walkerton, Ont., are lighting their woolen mill with gasoline.

MR. CHASE, of Chicago, will erect a saw mill on his timber limits at Secamous, Kamloops district, B. C.

MR. C. E. PETTES, West Brome, Que., is erecting machinery for the manufacture of an improved wood sap spout.

MR. JOSEPH ALDEN has bought and will operate the Miner steam lumber mill at South Roxton, Que., near Granby.

THE E. B. EDDY CO., Hull, Que., have started up their new paper mill and household utensil factory.

MR. T. SELBY, East Dunham, Que., is putting machinery into his steam saw mill to make cheese boxes.

THE MONTREAL RUBBER COMPANY, Montreal, will increase its capital stock from \$1,000,000 to \$2,000,000.

A PORTION of the works of the Dominion Oilcloth Company, Montreal, were destroyed by fire Dec. 20th, loss about \$6,000.

MESSRS. MOORE & McDONALD are erecting a lumber mill on the Saskatchewan river, 40 miles above Edmonton, Alberta.

MR. W. B. FOTHERINGHAM is erecting a saw and grist mill at Jubilee, Ont., a new town at the head of the Sault Rapids.

MR. J. H. FORBES, of the Star Woolen Mills, Hespeler, Ont., is in England purchasing worsted machinery for that concern.

MESSRS. NAISMITH & MERILEES, Blakeney, Ont., have enlarged their oat meal mill and added considerable new machinery.

THE BRANDON MILLING & ELEVATOR CO., Brandon, Man., with \$50,000 capital stock, will erect a flour and grist mill at that place.

MR. C. H. FLETCHER, Sherbrooke, Que., manufacturer of confectionery, etc., gives employment in his works to about 35 hands.

MR. THOMAS LUSTED, Stonewall, Man., has bought out the carriage and wagon-building business of Mr. Wm. Jefferson, of that place.

THE JOHN DOTY ENGINE CO., Toronto, have recently supplied the Deseronto *Tribune* with a Doty gas engine for running its presses, etc.

MR. JAMES JERMYN, Minnedosa, Man., having been granted a \$5,000 bonus, will refit and modernize his flouring mill at that place.

MR. JOHN HARRISON, Owen Sound, Ont., has completed the spacious brick building intended for his new sash and door factory.

MESSRS. HARPER & WEBSTER, Shediac, N.B., manufacturers of boots and shoes, thanks to the N. P., are doing a flourishing business.

THE St. Hyacinthe Manufacturing Co's knitting mills at St Hyacinthe, Que., were damaged by fire to the extent of about \$1,500 on Dec. 23.

MESSRS. RUDDOCK, HAGGERTY & HAYDEN, St Martins, N.B., will erect a mill near that place for the manufacture of all kinds of wooden ware.

MR. E. W. BEARDLEY, West Brome, Que., manufacturer of wagons, etc., is enlarging his works and will also make fine sleighs and carriages.

THE Atlas Woolen Co., late of Toronto, have removed to Whitby, Ont., and are fitting up a large woolen mill with the latest improved machinery.

THE Phenix Coal Company, St. John, N.B., have been incorporated with \$50,000 capital, and will operate the Joggins coal mines in that province.

THE carpet lining and stair pad factory of Messrs. Kirk & Hines, Bolton Centre, Que., was destroyed by fire Dec. 7th; loss on machinery about \$5,000.

THE Brantford Natural Gas Co., Brantford, Ont., has been incorporated with \$100,000 capital, and will explore for natural gas in that city and vicinity.

THE Owen Sound Dry Dock Company, Owen Sound, Ont., will build during the present winter another 150-foot barge for the Spanish River Lumber Co.

THE machinery required for the development of Mr. W. B. McAllister's oil well near Pembroke, Ont., has been received and is being put in position.

THE big timber raft recently built at Joggins, N.S., and which was being towed by a steamer from that place to New York, was abandoned at sea Dec. 18th.

MR. THOMAS WATERHOUSE will erect a woolen mill at Palmerston, Ont. The necessary by-law was voted on a few days ago, and carried by a vote of 159 to 21.

MR. JOHN LOVE, West Winchester, Ont., has purchased a suitable building which he is converting into a roller mill, to be driven by a 100 horse power engine.

MESSRS. ROBERT WARD & Co., Victoria, B.C., report that the shipment of packed salmon from that port during November last, aggregated 202,011 cases.

THE Brandon Milling & Elevator Co., Brandon, Man., has recently been formed with \$50,000 capital stock, and will build a flouring mill at that place.

THE Magog Textile & Print Co., Magog, Que., have received the machinery for their new cotton mill which is to be run in connection with their print works.

MESSRS. JAMES HAY & Co., Woodstock, Ont., manufacturers of furniture, rattan-ware, etc., are preparing to open up trade with China in goods of their make.

MESSRS. J. T. WESTON & Co., Tilsonburg, Ont., stove manufacturers, are asking that town to grant them a \$5,000 bonus to enable them to enlarge their business.

MESSRS. W. H. STOREY & Son., Acton, Ont., manufacturers of gloves, report that their trade during the past year was about \$25,000 greater than the previous year.

MESSRS. McMASTER, CARSON & QUINN, Brantford, Ont., have leased the Tisdale foundry in that town and will do a general business in brass and iron castings, etc.

THE new Grand Trunk Railway shops at Stratford, Ont., are nearly completed. It is claimed that the repair shop is the most substantial and best equipped in Canada.

THE Kingston & Pembroke Car Works Company, Kingston, Ont., have contracts to the value of \$300,000 on hand. The largest order is from the Canadian Pacific railway.

MESSRS. McCOLL BROS. & Co., Toronto, wholesale dealers in lardine and other machine and illuminating oils, have sent us a useful hanging office calendar for 1888.

THE Ontario Wheel Company, Gananoque, Ont., which was recently incorporated with a capital of \$50,000, expected to have put their works in operation this week.

MESSRS. EVANS, BROS & LITTLER, London, Ont., have received a \$10,000 bonus from Ingersoll, Ont., to start a branch of their piano manufacturing establishment there.

THE D. F. Jones Mfg Co., Gananoque, Ont., manufacturers of shovels, etc., have just put in some \$3,000 worth of new tools and machinery, the first of the kind in Canada.

THE gas vein struck on the farm of J. D. Simpson, near Chatham, Ont., is yielding 700,000 feet per day, about one-third the quantity estimated as sufficient to supply the town.

MR. JOHN TOYE, West Winchester, Ont., has placed an order with Messrs. Inglis & Hunter, Toronto, for a full equipment of machinery for his new roller mill at that place.

MESSRS. D. W. KARN & Co., Woodstock, Ont., manufacturers of parlor organs, contemplate adding to their present large business that of the manufacture of pipe or church organs.

MESSRS. JOHN BERTRAM & SONS, proprietors of the Canada Tool Works, Dundas, Ont., are in receipt of enquiries for machine tools from the Army Engineers' office at Havana, Cuba.

MESSRS. D. W. HOEGG & Co., of Fredericton, N. B., put up during the past season over half a million cans corn, peas and baked beans. They will build a new factory in the spring.

MESSRS. T. BENNER & SON, Owen Sound, Ont., having rebuilt their recently destroyed woolen mill and equipped it with all new and improved machinery, have put the same in operation.

MESSRS. HAMLIN & AYERS, Lachute, Que., are putting in a number of new looms into their woolen mills, an extra water wheel, and otherwise providing for their steadily increasing business.

RECENT advices from Burrard Inlet, B.C., state that at that time there were five large ships there loading lumber at the Moodyville Saw Mills for China, South America and Australia.

MESSRS. BANNERMAN BROS., Lachute, Que., manufacturers of rope, cordage, etc., who made considerable additions to their works last summer, are now operating them to their fullest capacity.

MESSRS. CHAPMAN & DRYSDALE, Lachute, Que., manufacturers of sashes, doors, etc., who recently increased the capacity of their factory, report that they have all the business they can handle.

MESSRS. MOORE & MCGARVIN, satchel manufacturers, Acton, Ont., deny through the *Free Press* that they asked a bonus from Galt to remove there. They say they have no intention of leaving Acton.

THE foundry department of the works of Messrs. H. R. Ives & Co., of Montreal, situated at Longueuil, near that city, was destroyed by fire December 21st; loss about \$15,000, covered by insurance.

A MONTREAL concern engaged in the manufacture of files are in correspondence with the authorities of Peterboro', Ont., with a view to locating works there. They want the usual bonusing indulgencies.

THE Quaco Woolen Manufacturing Co., St. Martins, N.B., whose splendidly equipped mill has been idle for more than a year, will put the same in operation, giving employment to some 30 to 40 hands.

MR. O. OUELETTE, Plessisville de Somerset, Que., woolen manufacturer, has introduced several looms into his factory for the manufacture of catalounes, or home made woolen ingrain carpets for the trade.

THERE is a clay pipe manufacturing establishment at Pamplin City, Virginia, which produces 50,000 of the celebrated Powhatan red clay pipes per day. We are not aware of any similar industry in Canada.

THE shipments of plaster from Windsor, N.S., during 1887, aggregated 111,393 tons, carried in 212 vessels, of which 153 were Canadian bottoms. More than two-thirds of this plaster—79,661 tons—went to New York.

THE pulp mill at Sheet Harbor, N.S., is now carrying on a flourishing business. Not less than \$1200 or \$1300 is circulated monthly by this establishment in wages, and from thirty to thirty-five men are constantly employed.

AMERICAN experts are prospecting for natural gas in the Ottawa valley. The indications are said to be excellent, and if the hopes of the projectors are realized a tremendous impetus will be given to the iron trade of that district.

MR. SLOANE, an expert from Pennsylvania, who is at present prospecting in Clarendon and Bristol townships, Pontiac county, has come to the conclusion that a vast reservoir of gas underlies that portion of the Ottawa valley.

MESSRS. LAURIE & BRO., Montreal, are building two pairs of 300-horse power each automatic steam engines for the sewer discharge works of that city, a description of the pumps for which was recently printed in these pages.

THE Canadian Pacific Railroad Company have been granted a bonus of \$20,000 by the town of Sault Ste Marie, Ont., and will immediately proceed to erect a round house, repair shops and other necessary buildings at that place.

THE City Roller Mills of Messrs D. H. McMillan & Bro., Winnipeg, Man., were totally destroyed by fire Dec. 8th, loss about \$40,000. These mills had but recently been completely refitted and refurbished and were in fine working order.

MR. A. McVEAN, Dresden, Ont., manufacturer of hubs, spokes and bent goods, informs us that he is now putting up an addition to his works 78x32 feet, two stories high, for the manufacture of "Sarven" and wood hub buggy wheels.

MR. W. H. STOREY, first vice-president of the Canadian Manufacturers' Association, and head of the firm of Messrs. W. H. Storey & Son, glove manufacturers, Acton, Ont., was elected Reeve of Acton by acclamation on December 26th.

MESSRS. HARRIS & Co., St. John, N.B., have been awarded the contract to build ten cars of the Eastman heater pattern for the Intercolonial Railroad, for the carriage of all kinds of perishable goods. The cars will be utilized this winter.

MR. JOHN FENSOM, of the Fensom Elevator Works, Toronto, has been appointed one of the examiners in connection with the application for the position of Chief Engineer for the Toronto pumping house, in place of Mr. Kennedy, C.E., of Montreal.

MESSRS. THOMPSON & Co., Sherbrooke, Que., manufacturers of bobbins and spools of every description, for woolen, cotton and rope mills, have contracted with the Ste Hyacinthe Woolen Mfg Co., for supplying them with bobbins for their new mills.

MR. DAVID HAMBLETON, Lachute, Que., proprietor of the Lachute Bobbin Factory, has recently added shuttle making machinery to his plant, and is now putting in another water wheel from which to obtain the power necessary to operate the same.

THE Ottawa Government has given an order to Mr. Michael Hurley, of Quebec, to apply his invention for heating railway cars by steam from the locomotive to a train on the Intercolonial Railroad, which is now being fitted up for the purpose at Levis.

MESSRS. J. C. WILSON & Co., Lachute, Que., paper manufacturers, have recently enlarged their mills and increased their capacity, and now have all the work they can handle. During the past summer they were annoyed somewhat by low water, but there is no scarcity now.

MESSRS. MCOUAT & MCRAE, Lachute, Que., founders and machinists, and manufacturers of stoves, plows, agricultural implements, etc., inform us that they recently made extensive additions and improvements to their works, and that they are operating the same full time.

THE Atlas Woolen Mills, Whitby, Ont., received their new boiler a few days ago. The *Oshawa Vindicator* says that this company expected to be granted a bonus, and that it was necessary to have \$8,000 worth of machinery placed before the loan could be demanded.

THE Acme Silver Company have been for some time experimenting on a new process for making silver-plated ware untarnishable. Mr. Parker says that it is going to prove a great success, and will be one of the best things for the trade that has ever been brought out.—*The Trader*.

THE office address of the Knowles Steam Pump Works has been changed from 44 Washington street, Boston, Mass., to 113 Federal street, same city, their New York office remaining as before at 93 Liberty street, as will be seen by reference to their card in our advertising pages.

MESSRS. COWAN & Co., Galt, Ont., manufacturers of Harris-Corless steam engines, etc., supplied the steam engine and boiler now in use in the *Empire* newspaper establishment in this city. The steam generated in these boilers is of a very expansive National Policy quality.

MESSRS. P. W. ELLIS & Co., Toronto, manufacturing jewelers and medalists, have contracted with the Dominion Rifle Association for the manufacture of the association medals to be competed for at the next annual prize meeting. Heretofore these medals have been made in England.

MESSRS. EDWARD P. ALLIS & Co., Milwaukee, Wis., manufacturers of engines, mining, saw mill, and flour mill machinery, mill and engine supplies, etc., have sent us a beautiful mounted hanger 1888 calendar. It also contains bird's eye views of the firm's Reliance and Bay State Works.

THE Martin steam-heating apparatus is being applied to eight cars in the shops of the Intercolonial Railroad at Moncton, N.B.,

and the Jamieson automatic fire extinguisher, for extinguishing fire in lamps and stoves in cars in case of collision or derailment, will be applied to several cars.

MESSRS. MAXWELL & SONS, Paris, Ont., foundrymen and manufacturers of agricultural implements, etc., are having inducements held out to them by Stratford, Ont., to have them remove their works to that place. They now give employment to over 150 hands. The bonusing business is still booming.

THE Paton Manufacturing Company, Sherbrooke, Que., have introduced electric light into their extensive woolen mills in that place. The company have recently put into their works two auxiliary steam boilers of 60 horse power each, manufactured for them by the Jenckes Machine Co. of Sherbrooke.

THE Canadian Lumber Cutting Machine Company which recently located here have prepared the foundations for the boiler and engine and are now awaiting the arrival of the machinery, etc. As soon as the plant arrives the factory will be pushed to completion to be ready for work in the spring.—*Belleville Intelligencer*.

MR. PETER KELLY, late of Hagersville, Ont., was in Brantford, Ont., a few days ago visiting the business men there for the object of learning public opinion in regard to the establishment of a boot and shoe factory there. His idea seems to be to get up a company and obtain the customary Brantford bonus.

THE Canadian Phosphate Company has been formed in London, England, with a capital of £110,000 sterling, and will acquire and develop the Star Hill, Williams and Ruby phosphate mines near Portland, Que., now being worked by the Union Phosphate Co. of New York, and manufacture chemical fertilizers.

THE village of Beeton proposes to lend a local manufacturer \$4,000 without interest, to enable him to brickcase and enlarge his factory; and Stratford has under consideration a proposal to bonus a Paris manufacturer to remove to Stratford. The municipalities should go into manufacturing enterprises out and out.—*Mail*.

MESSRS. ISRAEL ENGLAND & SONS, Knowlton, Que., manufacturers of hemlock tanned sole leather, superior lace and picker leather, loom straps, cut lacings, etc., inform us that their business is remarkably brisk, and that the use and consumption of these goods is almost universal in Canadian mills and factories.

THE Osborne-Killey Mfg Co., Hamilton, Ont., have completed and put in operation the pumping engines built by them for the water-works of that city. When tested they were found to far surpass in capability all that was required of them, and the consumption of fuel in operating them is much less than what the contract calls for.

MR. JAMES McLAUGHLIN, JUN., representing Messrs. James McLaughlin's Sons, Skaneateles Falls, N. Y., was recently on a business visit to some Canadian cities. This firm are well known teasel growers in the United States, and they state that they are in good condition to meet all the requirements of their Canadian business.

At Marthaville, Ont., three miles from Petrolea, they have jets of natural gas to private houses, which are conveyed to the heating stoves, and it gives a steady uniform heat, and for cooking. The gas is thrown on the wood and ignited. It is used in Courtwright to run a mill, and is said to save about \$10 a day for fuel.—*Planet*

THE Geo. F. Blake Manufacturing Co., builders of pumping machinery, etc., call attention to the fact that specimens of their goods may be seen at the Permanent Exhibition of Manufactures, 63 to 69 Front street west, Toronto. This company's Boston offices are at 111 Federal Street, and their New York offices at 95-97 Liberty Street.

THE Fire Extinguisher Mfg Company, Toronto, have recently built and delivered one of their magnificent chemical fire engines for the city of Hamilton. The generators are of great strength, having been tested to 300 pounds per square inch hydraulic pressure. The apparatus is first-class in every respect, and is of most attractive appearance.

MR. WALTER BEATTY, Pembroke, Ont., whose sash and door factory was recently destroyed by fire, has refused the offer of a \$3,000 bonus to assist him in rebuilding the same. He is not a bonus-hunting pauper. The protection offered him against foreign competition by the N. P. and his own individual energies, are what he depends upon for success.

THE Dominion Oilcloth Co., Montreal, who suffered a partial destruction of their works by fire December 19th, alluded to elsewhere in these pages, have issued a circular in which they state that the incident will not delay the execution of orders, as they have ample room and machinery in their other buildings to enable them to continue manufacturing as usual.

MESSRS. G. W. TICKELL & Co., Belleville, Ont., manufacturers of furniture, etc., have occupied their new and elegant salesrooms on King street west, this city, and are showing lines of their products which include mantels, cabinets, hall racks and tables, sideboards, bedroom and parlor suits, etc. The premises consist of three stories 90x27 feet and basement.

RUSSELL W. EATON, a native of Norridgewock, Maine, and a graduate of the State College at Orono, is superintending a cotton mill of seven hundred looms in Montreal, at a salary of \$5000 a year. He is a shareholder in the concern, and in the past two years has enabled the mill to pay a debt of \$60,000, and put over \$20,000 into its treasury.—*Lewiston (Me) Journal*.

THE ALBERT MFG Co., Hillsborough, N. B., during the past season made and shipped 18,000 barrels of calcined plaster to Moncton, for distribution, 15,000 barrels via the Intercolonial railroad to the upper provinces, two cargoes to Halifax, and quite a large number of cargoes to the United States. They state that as a result of the National Policy their business has more than quadrupled.

THE Selkirk Mining & Smelting Company are exhibiting in Victoria, B.C., a specimen of argentiferous galena taken from one of their mines at Illecillewaet. The piece is pure metal carrying 81½ per cent. of lead and 77 oz. of silver to the ton. There is not a particle of quartz to the specimen, which weighs upwards of a quarter of a ton, and is a part of a block over a ton in weight.

A COMMITTEE of the Toledo, Ohio, Business Men's Association were in Peterborough, Ont., a few days ago, and visited the flouring mills of Meldrum, Davidson & Co., to witness the Cochrane system of milling now in use there, a description of which has already been published in this journal. An immense mill is about being built in Toledo which is to be equipped with the Cochrane system.

MESSRS. DICK, RIDOUT & Co., Toronto, have removed their Toronto Bag Works from, 11 and 13 Front Street east, where their business offices are, to Bay Street near the Esplanade and adjoining the new stores of Messrs H E Hamilton & Co., at which place they will continue the manufacture of linen, cotton and jute bags for all purposes; hessians, for mattresses and bales; coat canvases, twines, etc.

MESSRS. JOHN BERTRAM & SONS, proprietors of the Canada Tool Works, Dundas, Ont., a few days ago poured the largest casting ever made in their establishment. It was the bed piece of a planer they are making for the new Cochrane roller mill manufactory now being built in Dundas. The tool when completed will be 30 feet long, 7 feet wide and about 1½ inches thick. The casting required 9 tons of metal.

MR. GEORGE STEVENS, Peterboro', Ont., has bought out the ashes business of Mr. Walshingham, that place. Mr. Stevens carries on this business in Napanee, Kingston and Belleville also, and is one of the largest ashes dealers in Canada. The ashes are taken to Napanee where the alkaline properties are separated, the bleached ashes being sent to the United States where they find ready sale as a fertilizer.

FOUR buildings of the extensive iron works of Messrs. W. S. Symonds & Co., Dartmouth, N. S., were destroyed by fire Dec. 15, loss about \$60,000. The machine shop, general foundry, stove plate foundry, car wheel foundry and water and gas pipe foundry were destroyed. The firm were engaged at the time of the disaster in filling a heavy contract with the Intercolonial Railway Company for water pipes.

MESSRS. B. GREENING & Co., proprietors of the Victoria Wire Mills, Hamilton, Ont., are calling attention to some of the lines of goods manufactured by them. They make special mention of bank and office counter railings in brass and iron; wire window guards, and fine wire blinds for inside windows. They are also manufacturers of perforated sheet metals, wire rope, wire cloth and wire work in all branches.

MESSRS. DICK, RIDOUT & Co., Toronto, have taken a long lease of the 150x100 foot vacant lot on Bay Street near the Esplanade, this city, adjoining their new bag factory, and propose to sub-let to parties who may desire to erect their own buildings for manufacturing purposes. They have abundance of power in their bag factory beyond their own requirements, and would supply power to any such new comers as might require it.

MESSRS. DICK, RIDOUT & Co., 11 and 13 Front Street East, Toronto, announce themselves as manufacturer's agents to the wholesale trade only, and solicit correspondence. They have removed their bag factory to another location, thus giving them plenty of



storage accommodation. They announce also that they are prepared to make advances on consignments. They have established branch offices at Montreal and Winnipeg.

MR. ARCHIBALD CAMPBELL, Markham, Ont., now runs 22 hand looms in his carpet factory. He will import a new loom for the manufacture of Kensington art rugs, which, it is said, will be the first loom of the kind in Canada, and will weave a piece four yards wide. Mr. Campbell does his own dyeing and all other branches of his work except spinning yarns. He first started in Toronto with a single hand loom, which he operated himself.

THE window glass trade of Canada is flourishing, and stocks not so heavy as at this time last year. A recent report states that there are 690 pots in operation in the western district, and only 54 idle; in the eastern district 264 are in operation and 24 idle, and in the northern district 156 are in operation, with only eight idle. The total number of pots in operation in the country is 1,110. The outlook for a brisk spring trade is unusually good.

MESSRS. E. LEONARD & SONS, London, Ont., have sent us a list showing the names of some of the purchasers of the Ball automatic cut-off engine in the United States, and of the Leonard-Ball engine in Canada, these latter having been built by Messrs. Leonard & Sons, the owners of the Canadian patent on these engines. The names of parties are mentioned who are using some 335 of these engines, quite a large proportion of which are in Canada.

THE Dominion Cartridge Co., Lachute, Que., now have their works in full operation and are doing a good business manufacturing ammunition. Their factory being outside the limits of the town they experienced some difficulty at first in obtaining suitable accommodation for their hands, but they have overcome this by themselves building a fine large first-class boarding house, which is heated throughout by steam, and fitted with all necessary conveniences.

MESSRS. MILLER BROS & MITCHELL, Montreal, manufacturers of the Beaudry upright cushioned power hammer, advertised in another page of this journal, request us to state that this hammer can be seen at the Permanent Exhibition, 63 to 69 Front Street West, Toronto. Messrs. Miller Bros & Mitchell are also manufacturers of hand, steam and hydraulic safety elevators for factories, warehouses, etc., dumb waiters, hoisting engines and machinery, ore crushers, etc.

MESSRS. BRYANT, GIBSON & Co., Toronto, manufacturers of pickles, sauces, etc., inform us that their business during the past year was exceedingly satisfactory. Their two leading specialties, John Bull pickles and John Bull sauce are fast becoming universal household necessities, and the demand for them is constantly increasing. They also report having done a very large holiday business in fine confectionery, having handled more than thirty tons of high class goods.

MR. H. E. CLARRY, brother of Mr. F. A. Clarry, Toronto, has formed a partnership with Mr. James Holt, to start a woollen manufacturing business under the style of Clarry & Holt. This mill will be located at either Orangeville or Toronto, and will be devoted to the manufacture of yarns. It will have a capacity at the start of two sets of English cards, and is expected to be in operation early in the new year, the machinery being now on its way.—*Journal of Fabrics.*

LUMBER dealers report that this season promises to be one of unusual activity in the woods. It is said that there are five camps in full blast this winter to every one in operation during the past two winters. The reason assigned for this is that last summer a large area of pine forest on the North Shore and Parry Sound district was over-run by fire. This necessitates the immediate getting out of the logs, because if they are allowed to remain over another season they will be worthless.

THE Martin Manufacturing Co., Whitby, Ont., are a new concern with \$50,000 capital, who have their works nearly ready for occupancy and will manufacture sadlery hardware in all its branches of wood, iron, brass and plated goods. These buildings cover nearly an acre of ground, included in which is a malleable iron works. They expect to be in operation early in January, and will give employment to from 75 to 100 hands, which number will be considerably increased later in the season.

MESSRS. GEO. F. HAWORTH & Co., 11 Jordan street, Toronto, who have just completed their new leather belting factory, have received an order for over two miles of leather belting for the new 1000-barrel flouring mill of the Lake of the Woods Milling Company at Keewatin, Ont. Included in this order is the following: 284 feet 18-inch belting; 518 feet 12-inch; 352 feet 10-inch; 743 feet 8-inch; 787 feet 7-inch; 1,700 feet 6-inch; 4,500 feet 5-inch and 2,500 feet 4 inch, aggregating 11,384 lineal feet.

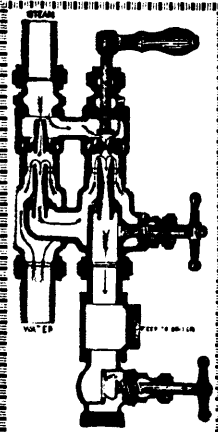

## JAMES MORRISON,

IMPORTER AND MANUFACTURER  
OF

Steamfitters' and  
Plumbers' Supplies

75 & 77 ADELAIDE ST. WEST,  
TORONTO.

SANITARY EARTHENWARE Now in Stock: Morrison's Washout Hopper  
National Water Closet.

Crown Water Closet.  
Inodoro Water Closet.  
Perfect Water Closet.  
Jenning's Valve Closet.  
Demarest Valve Closet.  
Alexander Valve Closet.  
A full stock of Washbasins,  
Urinals, etc.

Also, complete stock of Wrought  
Iron Pipe and Fittings.  
Brass and Iron Valves.  
Plumbers' and Steamfitters  
Brass Work.

Rubber Hose, Belting, Pack-  
ing, etc.

Sole Canadian representative of  
the Celebrated Hancock In-  
spirator.

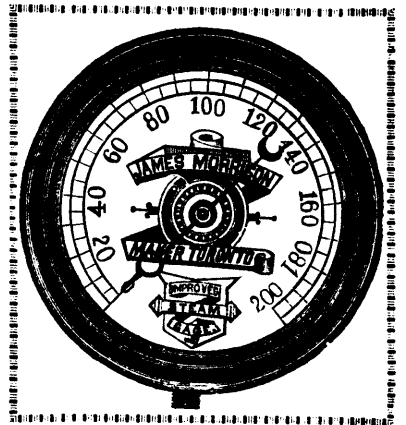

A COMPANY is being formed at Brantford, Ont., with \$100,000 capital, to bore for natural gas within the limits of that town, and to supply the gas to consumers. The authorities of the town have passed a by-law giving the proposed company the exclusive privilege for twenty years of boring for gas and laying gas mains in the streets. A search hole has already been bored down 1,000 feet, and strong indications of gas developed. The new company will commence a systematic development at an early day.

AN English builder of theatres has invented a panic lock for theatre doors. It is contained in a panel which occupies a large surface on the inside of the door. Any one coming in contact with the door must press the panel, upon which the door opens instantly. It is impossible for the doors of a building fitted with this lock to be fastened so that egress is prevented, but from the outside no entrance is possible except with a regular key. Terry's theatre in London has been fitted throughout with the new lock.

R. KELLY and W. Bailey have taken hold of the coal mine on Egg lake coulee, Sturgeon river settlement, and mine the coal for \$1 a load. The seam is eight feet thick and the coal is said to be of better quality than that taken out at Edmonton. It is taken from the face of a cut bank and has been mined for the past three or four winters by the surrounding farmers on the same principle as a sand pit, each one digging his coal as he required it. There is only about twenty feet of soil resting on the coal.—*Edmonton Bulletin.*

THE new case for which the American Watch Case Company, of Toronto, are applying for patents both in Canada and the United States, is said by American experts in that line of business who have examined it, to be the best and simplest screw dust-proof case ever invented. The only wonder is that it was never thought of before, as it is bound to revolutionize the watch case trade. The new machinery which the company had to get built for the manufacture of this specialty is now fully completed and running.—*The Trader.*

THE Dominion Safety Boiler Co., Montreal, of which Mr. J. F. Torrance, M.E., is manager, informs us that the high pressure boiler which they manufacture is of an entirely new type. It is claimed for them that they are cheaper and more durable and require less fuel than other styles. The first boiler of this design ever made in

Canada was placed in the machine shop of the Rathbun Co., Deseronto, Ont., some months ago, and the company are so well pleased with its remarkable performances that they are about to place two more of the same sort.

THE J. C. McLAREN BELTING Co, Montreal, have sent us a New Year's souvenir in which is represented a beautiful bare-foot maiden standing on the sands of the sea shore, playing with a child. It is a 12 x 18 inch mounted hanger, lithographed in several colors. The text of the card imparts the information that this concern have been in business 32 years; that they manufacture oak-tanned belting, using exclusively therefor imported leather; that they handle American, rubber and Chesapeake Gandy belting, and that they are general and textile mill furnishers.

THE Oneida Community, Community, N. Y., have sent us their illustrated list descriptive of the Oneida Community game traps manufactured by them. These goods are now made in thirteen sizes and three grades, known as the Newhouse, Hawley & Norton and Victor patent traps, and are specially made for trapping muskrat, mink, fox, otter, beaver, deer, bear, etc. This company publish "The Trapper's Guide," an 8vo. 216-page book for trappers, hunters and farmers, containing 32 full page illustrations, telling how to trap all kinds of fur-bearing animals, how to cure their skins, etc.

MESSRS. ROBERT MITCHELL & Co., proprietors of Montreal Brass Works, Montreal, are requesting the attention of readers of this journal to the automatic sprinklers with which they are prepared to equip cotton and woolen mills, factories, etc. The arrangement of the system is such that when fire occurs in a room equipped with these sprinklers, a copious discharge of water is sprayed over the room and all that may be in it, thus extinguishing the fire or retarding its progress until other help arrives. This is an important matter to all mill owners, and further information and estimates of cost will be furnished on application.

A NOTICEABLE feature in flour has been the receipt in this city of a carload from the Columbia Mills, Spallumcheen, B.C. This is the first to arrive in the city, and to those who think that this Province has no agricultural lands it will be a surprise. The flour is described as being very good, and is especially adapted for pastry and fancy baking. It will no doubt in time drive the Oregon and California flours out of the market for these purposes, just as the Manitoba hard wheat flour is driving them out for bakers' use. The demand for Manitoba flour still continues large and dealers are at times considerably pushed to fill orders.—*Vancouver, B.C., News.*

MR. JOHN CONNOR, of Messrs. Thomas Connor & Sons, proprietors of the New Brunswick Cordage Works, St. John, N.B., who was in Toronto this week, states that the consumption of binder twine in Canada has been rapidly increasing since the introduction of the self-binding harvester, until now the annual requirement is about 2,600 tons. Of this amount only about 40 tons were imported last season, entirely from the United States. Canadian twine is the equal of any made abroad, and superior to that made in the United States, while the price to the consumer is fully 2½ cents a pound less. A great deal of the binder twine consumed in Dakota is carried there from Winnipeg, Brandon and other distributing points in Manitoba.

THE Dangler Stove & Manufacturing Co., Cleveland, Ohio, have sent us their 1888 illustrated catalogue descriptive of the vapor stoves, etc., manufactured by them. These stoves are made in one, two, three and four burner styles, and with and without baking ovens, and in variety to suit all tastes and requirements. They are made in both wrought steel and cast iron frames, have automatic lighting attachments and a drop reservoir. This reservoir has to be turned down to be filled, by doing which all the fires are automatically put out, obviating all risk and danger from accidents. Other goods described include a combination tinner's and plumber's gasoline furnace and firepot, oil and gasoline wall lamps and torches, hand torches, etc.

THE National Hot Water Company has been organized in Boston to manufacture in the United States the Spence hot water boilers, which have been for many years manufactured in Montreal by Messrs. Rogers & King. The new company will push the sale of these heaters, and branches or agencies are to be established in all the principal cities in the Union. From the very general attention which is being given to the subject of heating by hot water at this time in the States, and the large and satisfactory business which Messrs. Rogers & King have enjoyed throughout the Dominion, it would seem that the prospects of the new enterprise are decidedly promising. Mr. James C. King, of Montreal city, is president of the new company.

## GALT FILE WORKS.

F. Parkin, Galt, Ont.  
Manufacturer of all kinds of Files and Rasps.

*Equal to the Jowitt File.*

*All Work Guaranteed.*

*Recutting of all Description.*

Send Postal for Terms and Discounts

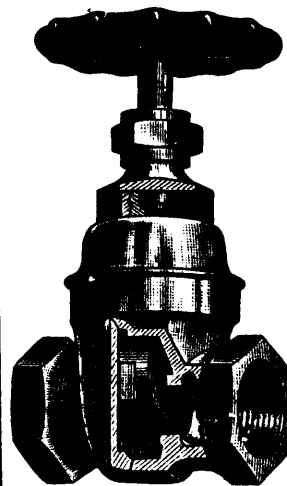

### WEBER'S PATENT Straightway Valves

FOR

STEAM, WATER AND GAS,

BEST VALUE IN THE MARKET.

**KERR BROS.**

Walkerville, Ont.

Sole right to manufacture in the Dominion.  
Send for Price Lists.

Also manufacturers of COMPOUND MARINE  
AND STATIONARY ENGINES.

THE Excelsior Mfg Co., St. Louis, Mo., manufacturers of the celebrated Charter Oak and other stoves and ranges, have sent us a series of twelve beautiful monthly calendars for 1888, each month having a special design, illuminated in colors. Some of the illustrations are even more appropriate for Canada than for the warmer but not so pleasant latitude of St. Louis—January showing a merry moonlight sleighing party welcoming in the new year; February a skating scene, the prominent figure representing what would readily be taken for our typical Miss Canada; March shows a beauty with disheveled hair and boreas-disturbed drapery; September a Canadian lawn tennis scene; October a wealth of gorgeous colors as only Canadian forests can present, and December a toboggan and snow-shoeing scene such as all Canada is now enjoying.

MESSRS. GEO. F. HAWORTH & Co., 11 Jordan Street, Toronto, as will be seen by reference to their full page card on page 9 of this issue, introduce themselves to all users of belting in Canada as manufacturers of oak-tanned leather belting. They have their new factory in operation at the location above indicated, and are prepared to respond promptly to any and all demands that may be made upon them for goods in their line. They will be pleased to send samples and prices on application. Mr. Haworth, the senior member of this firm, has been long and most favorably known to the trade as the Canadian manager of the business of Messrs. H. L. Fairbrother & Co., leather belting manufacturers, Providence, R.I. A practical manufacturer himself, he has secured the services of a number of practical mechanics, who, with the new and improved machinery with which his factory is equipped, guarantees the production of best, first-class work always.

We recently alluded to the fact that the Randolph Paper Box Co., of Richmond, Va., was probably the largest and most thoroughly equipped paper box factory in the world, and that they confine themselves exclusively to the manufacture of paper boxes and similar supplies for druggists, physicians and watch manufacturers. This concern was started in 1877 by Mr. N. V. Randolph with a capital of only \$627, and a force of four girls, one man and two boys. Now these works have a capacity to produce 206,000 boxes every day of ten working hours, and give employment to over 425 hands. The factory building is five stories high with a floor space aggregating

45,250 square feet. More than eight hundred different kinds of boxes are made, which vary in price to the jobbing trade from 15 cents to \$60 per gross. A large proportion of the employes are women and girls, who earn from \$3 to \$10 a week—some of them much more. Most of the boxes of this description used in Canada are made in this establishment.

THE Jenckes Machine Co., Sherbrooke, Que., now one of the most flourishing concerns in Lower Canada, is the outgrowth of the old firm of Messrs. S. B. Jenckes & Son, who for many years conducted a foundry business in that town. On its formation the new company purchased the business, the workshops, plant and machinery of the Smith-Elkins Manufacturing Company, and not only utilized the old stand but have erected several substantial new buildings which afford greater convenience for carrying on their business. The brick building on the Magog, formerly used as a machine, foundry and boiler shop, is now converted into one large machine-shop to which, in addition to the machinery purchased at the time of the change of firm, they have brought those formerly in use at their old stand. This building, 100 ft x 40 ft is now full of machinery used in the trade, and their appliances for turning out work of all kinds and description are complete in every respect.

THE Osborne-Killey Mfg Co., Hamilton, Ont., were the manufacturers of the pumps and pumping machinery recently placed in the waterworks of that city, and the *Spectator* is so enthused over the successful operation of them that it breaks forth into song and warbles thusly concerning "The Killey Pump":—You may tell us of the Holly, and of great hydraulic rams—Of hydrostatic wrinkles, and of queer dynamic cams; But if you wish to hurt a man, and make him somewhat hump, Say, How is Mr. Doran? Are you mashed on Killey's pump? A pump with many suckers is the pump that soon goes dry; But the pump the people's gone on throws the water near ski-hi. If you want to run a winning horse, when'er you take the stump, Just boost your man a mile or two with Killey's Champion pump. It runs as smooth as sweet-oil and is a machine of ease; It slashes up the water where it feels the mountain breeze; It oscillates so sweetly, and is never known to jump, The pump the people's mashed on is our Mister Killey's pump.

THE Rotary Snow-plow Company of Canada are the owners of the patents on the machine invented by Mr. Orange Jull, of Orangeville, for clearing railway tracks of ice and snow. Two of these snow-plows are now building at the Polson Iron Works, Toronto, for use on the Intercolonial and the Canadian Pacific railways respectively. The invention is already in use on the leading roads of the United States, and fifteen plows are now under construction at the locomotive works in Paterson, N.J. The plow is a ponderous affair, which runs upon the railway track like an ordinary snow-plow, but instead of making headway by dint of sheer force and the dividing of the snow drifts, it removes the snow bodily from the track by means of a set of rapidly revolving steel shovels operating in a great drum. By this contrivance the track can be cleared at the rate of twenty miles an hour, the snow, if desired, being thrown two hundred feet away from the track. No matter what the character of the snow, wet or dry, loose or packed, clear or mixed with sand, the result is accomplished with equal facility. The work is completed by what is called a "flanger," which, even in a deep drift, clears the rails perfectly so that even the heaviest trains can follow without danger of stalling. To avoid the possibility of the plow itself being derailed there is an ice-cutter attachment which removes the ice from the rails in front of the wheels of the forward truck. The machine, it is claimed, will do the work of a hundred laborers, and do it at the rate of twenty miles an hour, being thus one of the greatest labor-saving inventions ever brought before the attention of railway managers.

THE Hespeler, Ont., Woolen Mills, had occasion lately to advertise for a man to take charge of their English mules. A few days after, the manager was surprised by the appearance before him of a genuine Texas cowboy, in all the outre extravagance of dress and personal appearance that Beadle and Buffalo Bill have done so much to make the whole world acquainted with. He further astonished the manager with his familiar "Say, Mister!" and the assertion, "I'm yer man!" "Man for what?" asked his perplexed interlocutor. "Why, to take charge of yer mules as yer advertised fur. I'm yer man! I know 'em clean through and from way back; and though I'm no great kicker myself, I was almost with 'em. Can drive 'em single, or double, or tandem, an' if they are green, can break 'em as docile as a greaser at the muzzle end of a shooter, an' take the kick out of 'em so quick a Jack rabbit would think himself slow when putting in his best licks." "But," said the manager, attempting to explain, "these are English mules." But Texas didn't care a continental whether they were English, Irish, Dutch, native, or nigger. There were lots of them people in

Texas and all of them hadmules, and he never saw any difference; and the only way to convince him that he could not handle English mules was to trot the animals out. As this was inconvenient, he was taken in to see them, and then his rage knew no bounds. To call a baby railroad carriage that was too tender-footed to run outdoors, and stopped and started at each end of its six-foot rail, as if it were or had been across the plains and back and could be tended by a little gal, mule, he, with many oaths, asserted was the queerest of notions; and to want a man to take charge of it, and it tethered and staked at head and flank and belly and back, was the meanest of swindles; and with many more oaths, declared if he had not parted with his arms for things more desirable, he would levy a contribution then and there to assist him to a place where people were not such asses as not to know a mule from a wagon!—*Wade's Fibre and Fabric.*

## FIRE PROTECTION

BUILDINGS EQUIPPED

WITH

### AUTOMATIC SPRINKLERS

BY

### ROBERT MITCHELL & CO.

MONTREAL BRASS WORKS,

Write for estimates. MONTREAL.

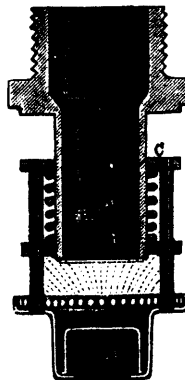

## Dick, Ridout & Co.

MANUFACTURERS' AGENTS

TO THE

WHOLESALE TRADE ONLY.

STORAGE ACCOMMODATION. ADVANCES MADE.

HEAD OFFICE:

11 & 13 FRONT ST. EAST,  
TORONTO.

Branches: Montreal and Winnipeg. Correspondence Solicited. References Given.



## MILITIA.

SEALED TENDERS, marked on the left hand corner of the envelope, "Tenders for Militia Store Supplies and Necessaries," addressed to the Honorable the Minister of Militia and Defence, will be received up to noon of Monday, 19th December.

Printed forms of tenders, containing full particulars, may be obtained from the Department at Ottawa, and at the following Militia Stores, where also sealed patterns of all articles may be seen, viz:—The offices of the Superintendents of Stores at London, Toronto, Kingston, Montreal, Quebec, Halifax, N.S., and St. John, N.B.

No tender will be received unless made on printed forms furnished by the Department.

The material of all articles will be required to be of Canadian manufacture and of Canadian workmanship.

Each tender must be accompanied by an accepted Canadian bank cheque, for an amount equal to ten per cent. of the total value of the articles tendered for, which will be forfeited if the party making the tender declines to sign a contract when called upon to do so, or if he fails to complete the service contracted for. If the tender be not accepted, the cheque will be returned.

C. EUG. PANET, Colonel,  
Deputy of the Minister of Militia and Defence

OTTAWA, 26th November, 1887.

THE

**PERMANENT EXHIBITION****Of Manufactures, and Commercial Exchange,****63, 65, 67, 69 FRONT STREET WEST (OPP. QUEEN'S HOTEL).****NICHOLLS & HOWLAND, TORONTO.****DIRECTORY OF EXHIBITORS:**

The following firms are already represented in the Permanent Exhibition. Their manufactures have a deservedly high reputation, and are recommended to the notice of intending purchasers of any of the respective lines in the following list. Prices, terms, discounts, etc., may be obtained from the several firms direct, or from Messrs. Nicholls & Howland, Permanent Exhibition of Manufactures:

- Armstrong, J. A. & Co., Guelph, Ont., Carpets.  
 Automatic Refrigerator Co., Ottawa, Ont., Haurahan's Patent Automatic Refrigerators.  
 Barnum, The Wire and Iron Works, Windsor, Ont., Wire Goods of all descriptions,  
 Bailing, Cresting, Fencing, etc., etc.  
 Barber & Ellis Co., The, Toronto, Ont., Manufacturing and Wholesale Stationers,  
 Account Books, Office Sundries, etc.  
 Bestram, John & Sons, Dundas, Ont., Iron and Wood Working Machinery.  
 Blake, George F., Manufacturing Co., Boston, Mass., Steam Power Pumping Machinery.  
 Bockh, Charles & Sons, Toronto, Ont., Brooms, Brushes, Woodenware, etc.  
 Breithaup & Co., Berlin, Ont., Leather.  
 Brush, George, Eagle Foundry, Montreal, P.Q., Blake Stone Crusher.  
 Bostwick, George F., Manufacturer in Canada of Amberg's Cabinet Letter Files  
 Baines, Geo. W., Montreal, National Water Purifier.  
 Batten, John, Pittsburg, Pa., Automatic Fire Escape.  
 Beatty, Wm. & Sons, Welland, Ont., Centrifugal Pumps and Contractors' Machinery.  
 Clare Bros. & Co., Preston, Ont., Stoves and Furnaces.  
 Cote, Louis & Bros., St. Hyacinthe, P.Q., Boots and Shoes.  
 Cowan & Co., Galt, Ont., Wood Working Machinery, Engines and Boilers.  
 Croelman Bros., Georgetown, Ont., World's Star Knitting Machinery.  
 Crompton Corset Co., Toronto and Berlin, Ont., Corsets.  
 Canadian Harness Co., Toronto, Harness and Saddlery.  
 Ching, J. Lionel & Co., Sydney, N.S.W., "Dugoug" Oil and Ointment, and "Dugoug"  
 Ivory Tusks and Hide.  
 Canada Screw Co., Hamilton, Ont., Wood Screws, Set Screws, Bolts, etc.  
 Duperow Bros. & Co., Toronto, Varnishes, Japans, etc.  
 Dalley, F. F. & Co., Hamilton, Ont., Extracts, Essences, Blacking, and Grocers'  
 Sundries.  
 Donald Produce Co., Norwich, Ont., Evaporated Fruits.  
 Doty Engine Co., Toronto, Ont., Engines, Boilers, etc.  
 Dominion Barb Wire Co., Montreal, P.Q. (C. A. DeLisle Western representative), Barb  
 Wire, Plain Wires and Wire Rope.  
 Dovercourt Twine Mills, Toronto, Ont., Twines and Cordage.  
 Dominion Starch Works, Walkerville, Ont., Corn Starch and Laundry Starch.  
 Dominion Show Case Co., Toronto, Show Cases.  
 Elliot & Keighley, Toronto, Ont., Coffees, Spices.  
 Elliot & Co., Toronto, Ont., Manufacturing and Wholesale Chemists and Druggists.  
 Ellis, P. W. & Co., Toronto, Ont., Manufacturing and Wholesale Jewellers.  
 Fenwick & Solater, Montreal, Que., Files and Mill Supplies.  
 Finch, W. B. Toronto, Wood Filler and Preserver.  
 Gate City Stone Filter Co., New York, Water Filters.  
 Gillies, John & Co., Carleton Place, Ont., "Shipman's" Coal Oil Engines and Steam  
 Launches.  
 Globe Tobacco Co., Windsor, Ont., and Detroit, Mich., Tobaccos.  
 Goodhue & Co., Danville, Que., Leather Belting and Lace Leather.  
 Grand & Toy, Toronto, Ont., Tucker Automatic Letter and Document Files.  
 Grand River Knitting Mills, Co., Paris, Ont., Smyrna Rugs and Knit Goods.  
 Grape Sugar Refining Co., Walkerville, Ont., Syrups and Glucose.  
 Gray, Wm. & Sons, Chatham, Ont., Carriages and Sleighs.  
 Gillett, E. W., Toronto and Chicago, Yeast and Baking Powder.  
 Gardner, W. K., Montreal (successor to H. H. Warren), Manufacturer of every descrip-  
 tion of Hammers.  
 Gurney, The E. & C. Co., Hamilton and Toronto, Gravity Springless Locks, and Rotating  
 Door Knob Furniture.  
 Gurneys' & Ware Scale Co., Hamilton Ont., Platform and Counter Scales.
- Hudson Bros. (Limited), Sydney, N.S.W., Australian Timber and Cabinet Woods.  
 Hamilton Industrial Works Co., Hamilton, Ont., Wringers, Mangles, etc.  
 Hart Emery Wheel Co., Hamilton, Ont., Emery Wheels and Emery Wheel Machinery.  
 Hay, Peter, Galt, Ont., Machine Knives.  
 Hearle, J. G., Montreal, Que., Toilet Soaps and Perfumery.  
 Howland, H. S., Sons & Co., Toronto, Ont., Hardware Specialties.  
 Howland, H. S., Kleinburg, Ont., Flour.  
 Hemming Bros., Toronto, Ont., Fancy Plush Goods and Jewellers' Cases.  
 Herman, J. W., Toronto, Boiler Water Purifier.  
 Hamilton Whip Co., Hamilton, Ont., Whips.  
 Ives, H. R. & Co., Montreal, P.Q., Fencing, Cresting, Stoves and Hardware Novelties.  
 Jardine, A. & Co., Toronto, Ont., Coffee, Spices, and Pure Gold Baking Powder.  
 Jenkins & Co., Toronto, Ont., Bedding of all kinds.  
 Keer, Maj. Gen'l, Toronto, Ont., Himalayan Teas.  
 Kerr Bros., Walkerville, Ont., Water, Steam and Gas Valves of Improved Pattern.  
 King, R. W., & Co., Georgetown, Ont., Power Knitting Machinery.  
 Leslie, James, Montreal, Que., Woollen and Cotton Mill Supplies.  
 McCaskill, D. A., & Co., Montreal, Que., Varnishes and Japans.  
 Miller Bros. & Mitchell, Montreal, Que., Beaudry's Steam Power Hammer.  
 Munderloh & Co., Montreal, Que., Watchmen's Clocks.  
 Morris, A. W. & Bro., Montreal, Que., Cordage and Binder Twine.  
 Morrison James, Toronto, Steamfitters' and Plumbers' Supplies.  
 McLaren, The J. C. Belting Co., Montreal, Mill Supplies.  
 Montgomery, L. B., Toronto, Mill Supplies.  
 North, Wm. & Sons, Leeds, England, Teazels.  
 Northey & Co., Toronto, Ont., Steam Pumping Machinery.  
 Northumberland Paper Co., Campbellford, Ont., Straw Board and Tarrd Paper.  
 Ontario Bolt Co., Toronto, Ont., Bolts, Nuts, Spikes, etc.  
 Oshawa, Stove Co., Oshawa, Ont., Cooking and Heating Stoves.  
 Pepper, T. & Co., Guelph, Ont., Carriage and Wagon Axles.  
 Ferrich, M., Parkdale, Ont., East Indian Specialties.  
 Pillow, Hersey & Co., Montreal, Que. (Geo. A. MacAgy, Western representative)  
 Nails, Tacks, Bolts, etc.  
 Poliwa Emil, Montreal, Que., Sapollo and Bronzes.  
 Pugh, Frank, Toronto, Ont., Brass Goods.  
 Ramsay & Son, Montreal, Que., Plate and Stained Glass, Paints, Oils, etc.  
 Robin & Sadler, Montreal, Que. and Toronto, Ont., Leather Belting and Lace  
 Leather.  
 Shurly & Dietrich, Galt, Ont., Saws of every description.  
 Simpson & Co., Berlin, Ont., Furniture.  
 Smith, R. H. & Co., St. Catharines, Ont., every description of Saws.  
 Stahlschmidt & Co., Preston, Ont., Office Desks, Chairs, School Furniture, etc.  
 Slight, H., Toronto, Florist.  
 St. Thomas Featherbone Co., St. Thomas, Ont., Featherbone Corsets, Whips, etc.  
 Strickland, George A., Lakeside Ont., Patent Cutter.  
 Taylor, John J., Toronto, Fire and Burglar Proof Safes, Vaults, etc.  
 Tees & Co., Montreal, Que., Revolving Book Cases, Wood, Carpets, etc.  
 Teller, Rothwell & Co., Montreal, Stove Polish, etc.  
 Toronto Lead & Color Co., Toronto, Ont., Prepared Paints, White Lead, etc.  
 Toronto Rubber Co., Toronto, Belting, Fire Hose, Etc.  
 Toronto Novelty Manufacturing Co., Toronto, Ont., Ironing Boards.  
 Watts, A. & Co., Brantford, Ont., Household Soaps.  
 Warren, H. R., representing The Meriden Britannia Co., Hamilton.

IN CONNECTION WITH OUR PERMANENT EXHIBITION WE HAVE EXCELLENT

**STORAGE—LIGHT, DRY, CLEAN.**

Our facilities for receiving and shipping are unsurpassed, and we invite inspection or correspondence.

SEND FOR ILLUSTRATED CIRCULAR.

**KNOWLES STEAM PUMP WORKS,**  
 —BUILDERS OF—  
**STEAM PUMPING MACHINERY IN EVERY VARIETY**

**BOILER  
 FEED,  
 FIRE  
 and  
 TANK  
 PUMPS**

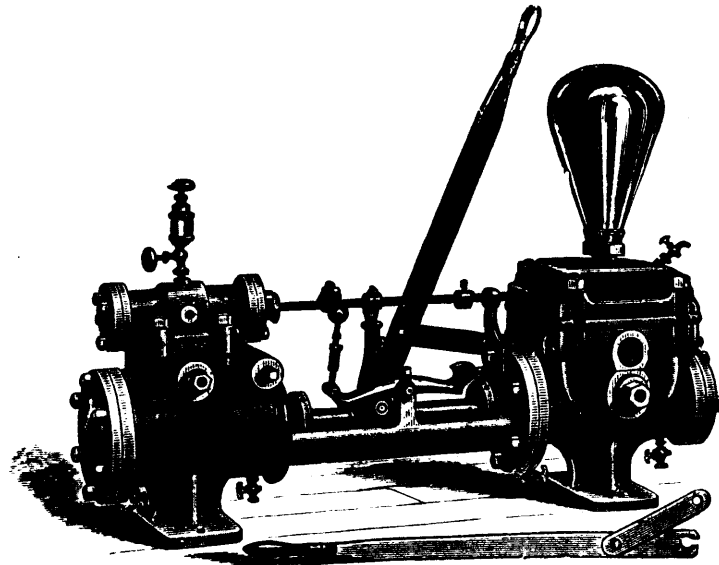

**Simple and Duplex  
 PUMPING  
 ENGINE  
 for  
 TOWN and CITY  
 SUPPLY.**

For Particulars, Address **113 Federal St., BOSTON.**

**93 Liberty St., NEW YORK.**

—SEND FOR ILLUSTRATED CATALOGUE—

*To Users of Glue.*

**W**E are manufacturing a reliable GLUE, and can supply a limited number of consumers only. We guarantee our glues to be made from selected stock, and to be of the same uniform quality. Glues not as represented, or not proving satisfactory, returnable at our expense.

**JAMES HAY & CO.**  
 WOODSTOCK, ONT.

**ARMSTRONG'S BUGGY AND CARRIAGE GEAR.**

The "Defiance"

**T**HIS GEAR meets the demand of the Driving Public for low-riding Buggies, and combines with this, lightness, durability, and great ease of motion. By the use of improved machinery and manufacturing in large quantities, we are enabled to make prices MODERATE. Send for our descriptive circular

**J. B. ARMSTRONG MFG. CO. (Ld.), Guelph, Ont.**

**The Doty Vertical Engine and Boiler.**

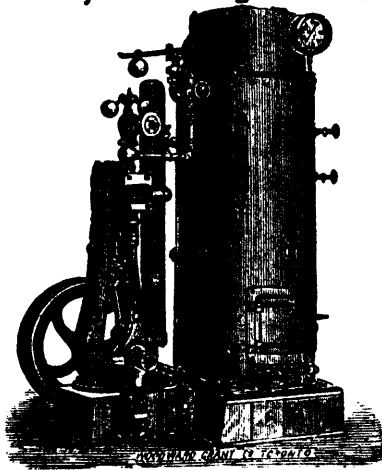

In sizes from 3 to 10 H.P. Specially adapted to places where 3 to 10 H.P. is required. Simple, safe and durable.

SEND FOR REDUCED PRICE LIST.

**JOHN DOTY  
 ENGINE CO.**

**No. 2 Bathurst Street.**

**TORONTO, ONT.**

**THE  
 Otto Silent Gas Engine.**

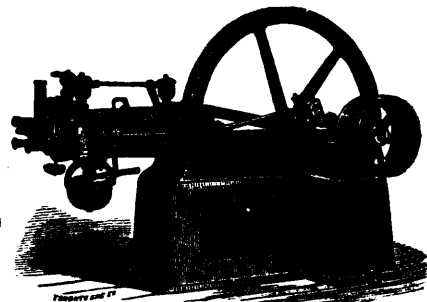

In sizes from 2 to 7 H.P. Most convenient power in the market.

SEND FOR CIRCULAR.

*THE J. A. CONVERSE*  
**MANUFACTURING CO'Y**

A. W. MORRIS & BRO., Proprietors,  
**MONTREAL.**

Manilla, Sisal, Russian and Jute Cordage, Red Cords, Lathies, Etc.	Red Cap Brand Manilla Binder Twine is always uniform.	Jute and Cotton Bags, Hessians Hop Sacking, Etc., Etc.	Calcined and Land Plaster, Portland Cement, Cod Oil all Brands.
--	--	--	---

**WM. LAURIE & CO.**  
MANUFACTURERS OF  
**SPOOLS AND BOBBINS**

OF ALL SIZES AND PATTERNS,  
FOR COTTON AND LINEN THREAD, MACHINE TWIST, SEWING  
SILK, AND FOR COTTON, WOOLEN AND SILK  
MANUFACTURERS.

*LOUISEVILLE, P.Q.*

*We respectfully solicit your patronage and guarantee our work to be first-class.*

**ST. CATHARINES SAW WORKS.**



**R. H. SMITH & CO.,**

ST. CATHARINES, ONT.,  
Sole Proprietors, in Canada, of the

**"Simonds" Saws**  
AT GREATLY REDUCED PRICES

All our Goods are manufactured by  
the "Simonds" process. Our Cir-  
cular Saws are unequalled. We man-  
ufacture the Genuine Hanlan, Lance  
Tooth, Diamond, New Improved  
Champion, and all other kinds of  
Cross-Cut Saws. Our Hand Saws  
are the best in the market, and as  
cheap as the cheapest. Ask your  
Hardware Dealer for the St. Catha-  
rines make of Saws

**THE LARGEST SAW WORKS IN THE DOMINION.**

**AHEAD**

OF ALL COMPETITORS IN CORDAGE!  
OF ALL COMPETITORS IN BINDER TWINE  
OF ALL COMPETITORS IN PLASTER!

And we open our NEW BAG WORKS early in 1888 with  
strong expectations of being

**AHEAD OF ALL COMPETITORS IN BAGS.**

**Geo. F. Blake Manufacturing Co.,**

BUILDERS OF

SINGLE AND DUPLEX

Steam and Power

**Pumping Machinery**

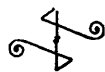

**BOSTON,**  
111 FEDERAL STREET.

**NEW YORK,**  
95 & 97 LIBERTY STREET.

SEND FOR ILLUSTRATED CATALOGUE.

These goods may be seen at the Permanent  
Exhibition, 63 to 69 Front Street West, Toronto,

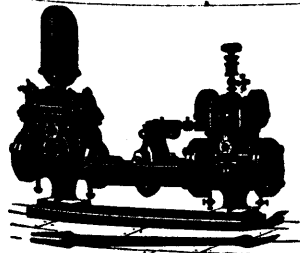

BOILER FEED PUMP.

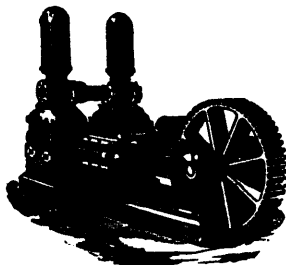

GEARED FEED PUMP.

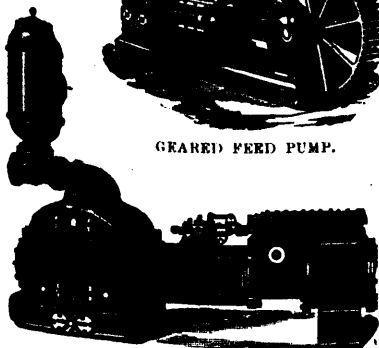

DUPLEX COMPOUND ENGINE.

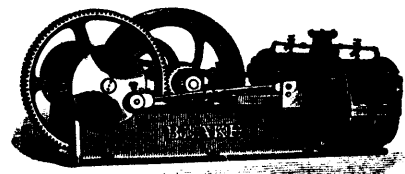

AIR COMPRESSOR.

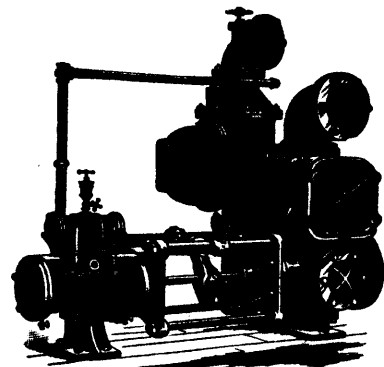

AIR PUMP AND CONDENSOR.

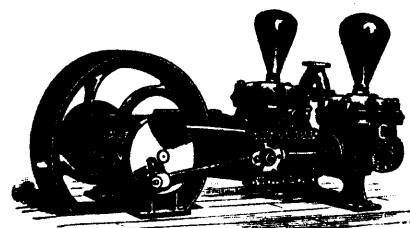

BELT PUMP

# Dodge Patent Wood Separable or Split Pulleys.

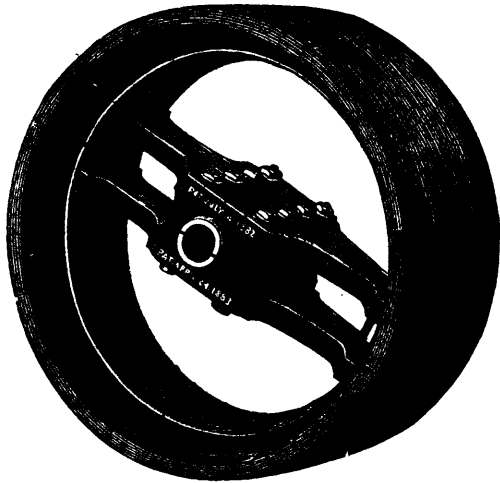

Best Belt Surface, Lightest, Strongest, Best  
Balanced and Most Convenient  
Pulley in the World.

## With our Patent Bushing System

Every pulley will fit 22 different sizes of shafting, and guaranteed to give from 30 to 60 per cent. more power from same belt and like tension than any iron or steel pulley. Every pulley a split pulley, 70 per cent. lighter than cast iron, and 50 per cent. lighter than wrought iron or steel. Strong enough for any power required. Made in any size from nine inches to sixteen feet diameter.

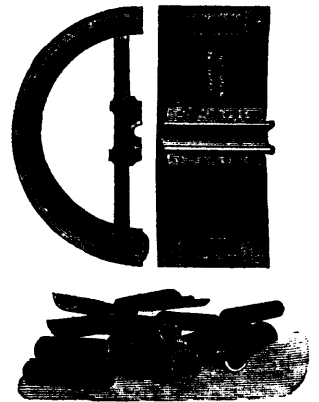

## THE TRANSMISSION OF POWER BY ROPES AND THE DODGE PATENT WOOD PULLEYS.

The great advantage of Wood over Iron as a material for belt pulleys (or drums) to transmit power economically, has induced the DODGE WOOD SPLIT PULLEY CO., of Toronto, to introduce grooved hardwood pulleys for the special purpose of transmitting power by ropes (manilla tallow laid), and in this connection Mr. Dodge has taken out Canadian Letters Patent for a system of applying the ropes, adjusting the pulleys, and taking up slack, that is giving the most unqualified satisfaction.

This system of transmitting power by ropes is cheaper and superior to belts in many cases, such as where the driver shaft is at right angles with the driven, also where the drive is perpendicular, particularly when it is quarter twist and perpendicular; also where the driver and driven are

close together; also for long drives, such as across a street, or a stream, etc. For transmitting power from an engine to the line shaft this system is unequalled; steady all the time, not like a heavy belt, which is always more or less flapping, jerking and stretching, then slipping and losing power. It is safe to say that an engine hitched up by the Dodge Rope System will do 25 per cent. more work on the same consumption of fuel than the same engine would do with a belt. We have put up a number of the Dodge Patent Rope transmissions during the past year, all of which are in most successful and satisfactory operation, as certified by the testimonials published in our catalogue of well-known manufacturers who have them in use.

WITH OUR SYSTEM OF MANILLA ROPE TRANSMISSION is overcome the objection to Wire Rope (because of crystallizing) and gearing, (because of loss of friction) and shafting (because of the liability to get out of alignment, hence loss of power by friction), and a separate engine plant (because of its great expense); on the contrary, with the Manilla Rope System, under the Dodge patents, the power is transmitted with the same efficiency as though the shafts were close together, there being no loss of power by excessive tension, or bad alignment, but simply the friction of the journals to overcome at the carriers, which have a strain of weight of the rope to carry.

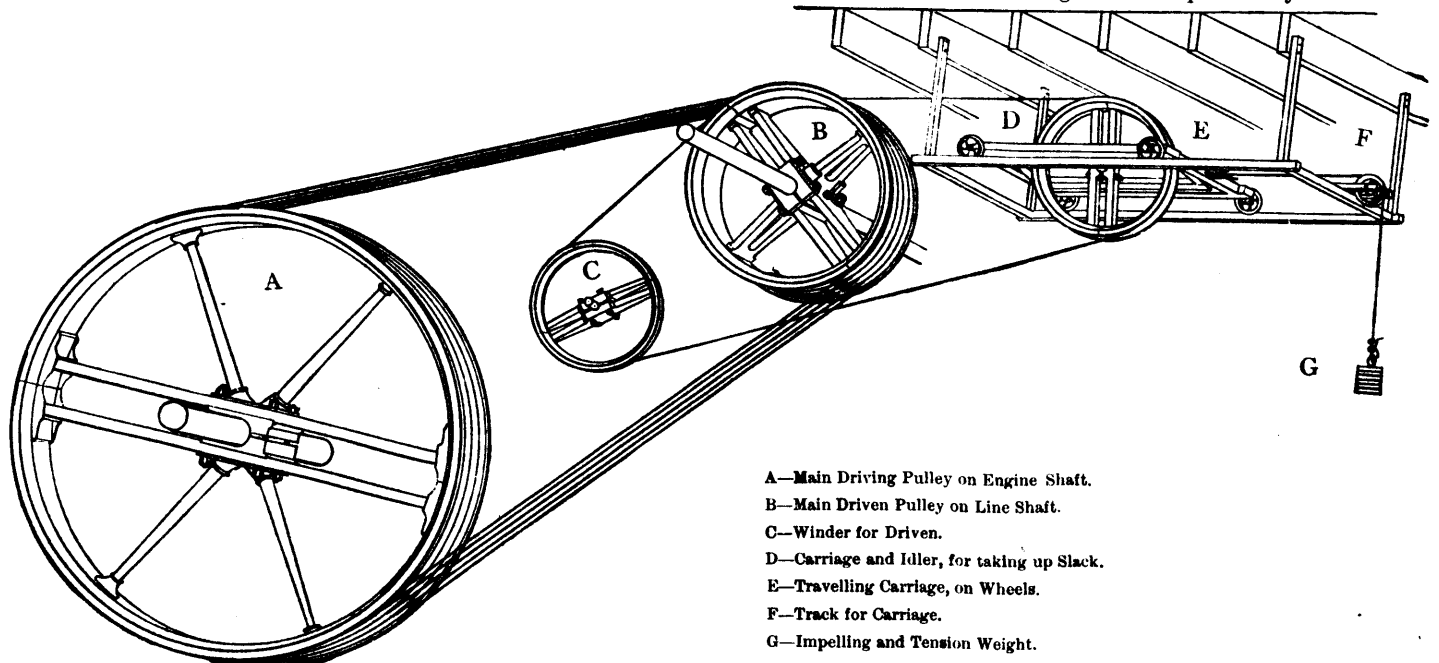

- A—Main Driving Pulley on Engine Shaft.
- B—Main Driven Pulley on Line Shaft.
- C—Winder for Driven.
- D—Carriage and Idler, for taking up Slack.
- E—Travelling Carriage, on Wheels.
- F—Track for Carriage.
- G—Impelling and Tension Weight.

The illustration, as shown above, is one of peculiar construction, and represents an engine transmitting its power to the line shafting by the Dodge Patent System of manilla ropes and grooved hardwood pulleys. Transmissions similar to the above are now in use at the works of the following well-known manufacturers in Toronto:—

A. R. Clark & Co., Leather and Glove Manufacturers, 50 H.P.; T. Tushingham & Son, Builders, 35 H.P.; J. R. Black, Carriage Works, 50 H.P.; Barber & Ellis Co., Stationers, 8 drives, 37 H.P.; Jas. Lochrie, Rope Manufacturer, 60 H.P.; J. P. Wagner & Co., Show Case and Keyboard Manufacturers, 50 H.P.; J. Taylor, Morse Soap Works, 60 H.P.; Joseph Simpson, Knitting Mills, 80 H.P.; and numerous others whose testimonials can be seen in our catalogue. Parties who are in want of anything in this line, or who are interested in the efficient and economical transmission of power, are cordially invited to call at our works and see the ropes and wood pulleys in operation, as we are driving our whole factory by this system. Send for Price List, Catalogue and Cypher Code, for ordering by telegraph, to

**THE DODGE WOOD SPLIT PULLEY CO., 89 ADELAIDE ST. W., TORONTO.**

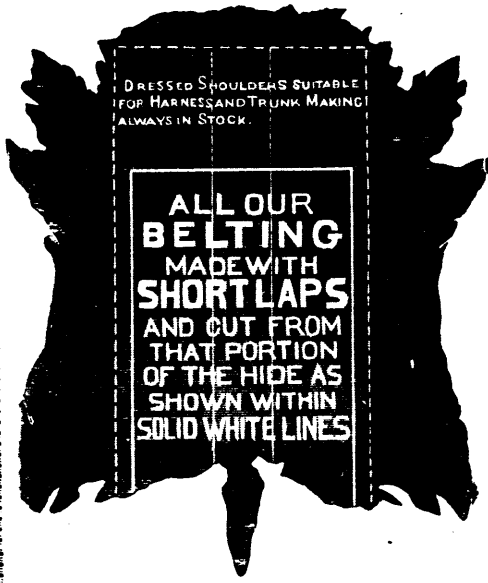

ROBIN & SADLER,  
 MANUFACTURERS OF  
**Leather Belting**

SEND FOR PRICE LISTS AND DISCOUNTS.

MONTREAL, 2518, 2520, 2522, Notre Dame St.  
 TELEPHONE 110 B.

TORONTO, 129 Bay St.  
 TELEPHONE 1101.

Mill Owners in the West will find it to their advantage to order their BELTING from our Toronto House.

We guarantee their orders well and promptly filled, for we keep on hand all sizes from 2 to 16 inch, **SINGLE AND DOUBLE**; also: Lace Leather, Belt Hooks, Belt Punches, etc., etc.

*Nova Scotia Steel Co., Limited,*  
 NEW GLASGOW, NOVA SCOTIA,  
 (Only Steel Works in Canada),  
 MANUFACTURERS OF

**Hammered and Rolled Steel**

MADE BY THE  
**SIEMENS-MARTIN (OPEN HEARTH) PROCESS.**

ROUND MACHINERY STEEL for Shafting, Spindles, etc. MILD STEEL for Rivets, Bolts  
 Thresher Teeth, and many purposes where Norway Iron is now used.

SPECIAL SECTION PLOW BEAMS, MILD STEEL CENTRE AND SOLID MOULD BOARDS,  
 COULTER STEEL HARROW DISCS,  
 AGRICULTURAL STEEL CUT TO PATTERN, SPRING, SLEIGH SHOE, TYRE, TOE CALK AND CROSS BAR STEEL  
 STEEL NAIL PLATE.

III Binder Bars, Z and other Special Sections.  
 STEEL MOWER BARS.

Particular attention given to the manufacture of Rake, Cultivator and Harrow Teeth, and other Agricultural Spring Steel Forgings.



# Parks' Cotton Manufactures

Awarded the Only "Gold Medal" Given at the Toronto Exhibition of 1885, for Cotton Goods.

*Fancy Wove Shirtings.*

FAST COLORS, - - FULL WEIGHTS.  
Quality always Equal to Samples sent out.

## COTTONADES.

Our celebrated line of Lansdowne Tweeds, the best value, for least cost, of any made in Canada.

## BALL KNITTING COTTONS.

Better Spun, Twisted, Bleached and Dyed than any other in the Market. For Sale by all Wholesale Houses.

No Goods Genuine Without Our Name Upon Them.

NO PRIVATE BRANDS.

WILLIAM PARKS & SON (Limited),  
ST. JOHN, N.B.

AGENTS :

Wm. Hewett, Toronto;  
Duncan Bell, Montreal;  
Bedard, Girard & Co., Quebec.

# WALTERS' PATENT METALLIC SHINGLES

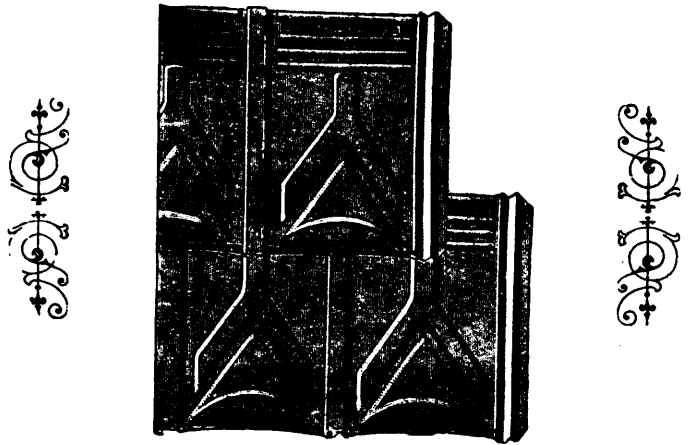

They make the Most Durable Metal Roof known.  
They make the Cheapest Metal Roof known.  
They are Attractive in Appearance.  
They Lessen your Insurance.  
They are one-third the weight of wood.  
They are one-ninth the weight of slate.  
They can be put on by ordinary workmen.  
A good roof is as important as a good foundation.

Send for circulars and references. Sole Manufacturers in Canada.

McDONALD, KEMP & CO.

Cor. RIVER AND GERRARD STREETS, - - TORONTO, ONT.

## SHURLY & DIETRICH, Galt, Ont.

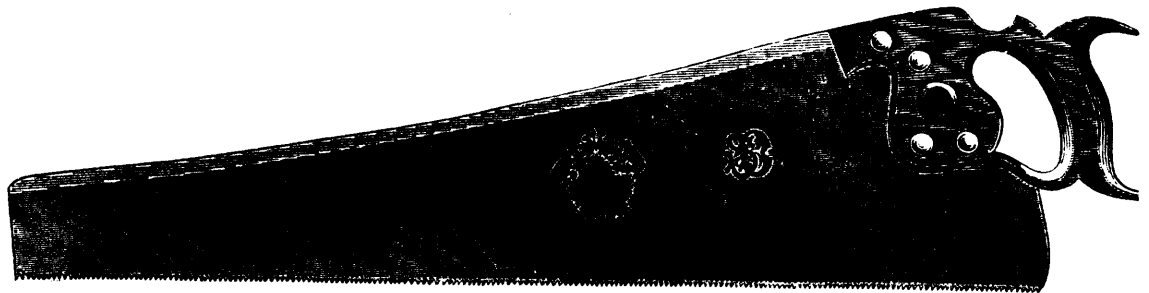
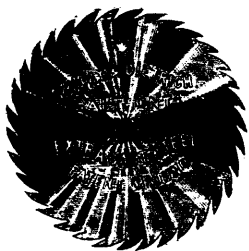

MANUFACTURERS OF SAWS OF ALL KINDS.  
LARGEST SAW MANUFACTURERS IN CANADA.

Sole Proprietors of the Secret Chemical Process of Tempering.  
Our Silver Steel Saws are unequalled.

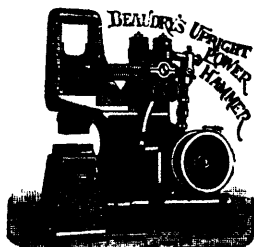

SIMPLE,  
PRACTICAL,  
LOW PRICED.



ENTIRELY  
NEW  
DESIGN.

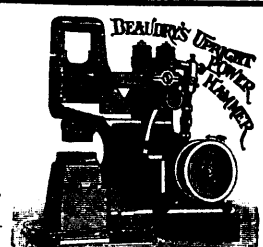

## BEAUDRY UPRIGHT CUSHIONED POWER HAMMER.

Does not vibrate.  
Requires no helper.  
Always ready for use.  
Does not chill the work.

Gives a perfectly square blow.  
Has open space between the dies.  
The stroke can be changed easily and quickly.

Will give one blow or more as required, light or heavy.  
Can be run cheaply and with very little power.

The anvil is entirely separate from the frame.  
It is the least complicated and most efficient power hammer in the world.

This Hammer may be seen at Permanent Exhibition, Toronto, Ont.

SEND FOR PRICE LIST.

MILLER BROS. & MITCHELL, Sole Makers for Canada, MONTREAL.

**AUSTRALIA—IMPORTANT TO MANUFACTURERS.**

Established 1878.

# ALBERT S. MANDERS & CO.,

**THE AUSTRALIAN COMMISSION HOUSE.**

Head Office, 30 Collins Street, MELBOURNE, also at King Street, SYDNEY, and King William Street, ADELAIDE.

Agency Wanted for First-Class Goods. Samples should be sent with Lowest Prices to our Head Office.

NOTE.—We are the Only Firm that have a Branch House in the three Leading Colonies.

LONDON, 11 Mansion House, Chambers, 10 Queen Victoria St., E.C. NEW YORK, Mayo & Watson, Australasian Office, 22 & 23 State St. CANADA, Nicholls & Howland, 63 Front St. West, Toronto.

## THE INTERCOLONIAL

**RAILWAY OF CANADA.**

*The Royal Mail Passenger and Freight  
Route between Canada and  
Great Britain,*

AND

Direct Route between the West and all points on the Lower St. Lawrence and Bale de Chaleur, also New Brunswick, Nova Scotia, Prince Edward's Island, Cape Breton, Newfoundland, Bermuda and Jamaica.

New and elegant Buffet Sleeping and Day Cars run on Through Express Trains.

Passengers for Great Britain or the Continent by leaving Toronto per 8.30 a.m. train Thursday, will join outward Mail Steamer at Halifax a.m. Saturday.

Superior Elevator, Warehouse and Dock accommodation at Halifax for shipment of grain and general merchandise.

Years of experience have proved the Intercolonial, in connection with Steamship lines to and from London, Liverpool and Glasgow to Halifax, to be the quickest Freight route between Canada and Great Britain.

Information as to Passenger and Freight Rates can be had on application to

**ROBERT B. MOODIE,**

Western Freight and Passenger Agent, 93 Rossin House Block, York Street, TORONTO.

**D. POTTINGER,**

Chief Superintendent.

Railway Office,  
Moncton, N.B., Nov. 22nd, 1886.

Patent Double Tongue and Groove  
**Fire-Proof Safes.**

**J. & J. TAYLOR**

**SAFES**

**SAFES**

STEEL PLATE UNDER  
LOCK TO  
PREVENT DRILLING.

DRY AIR CHAMBER  
TO  
PREVENT DAMPNESS.

HEAD OFFICE AND MANUFACTORY:  
117, 119  
FRONT STREET EAST,  
TORONTO.

# JAMES LESLIE

MANUFACTURER OF

## MACHINE CARD CLOTHING AND LOOM REEDS.

LEATHER BELTING

LACE LEATHER

HOSE



COTTON AND WOLLEN MILL SUPPLIES

## COTTON LOOM HARNESSES AND WIRE HEDDLES

OFFICE AND FACTORY  
JUNCTION OF CRAIG AND ST. ANTOINE STREETS.  
**MONTREAL.**

# The Canadian Manufacturer

IS THE OLDEST TRADE JOURNAL PUBLISHED IN CANADA,

And is the only paper in the Dominion published entirely in the

INTERESTS OF CANADIAN MANUFACTURERS.

---

All the various manufacturing industries of Canada are represented in its columns, and it is and always has been the fearless and consistent advocate of those reforms indispensable to the success of home manufacturing industries.

---

AS REGARDS THE INTERESTS TO WHICH IT IS DEVOTED, IT IS THE

Best Advertising Medium in Canada.

---

ITS ADVERTISING RATES ARE REASONABLE.

*Specimen Copies, with Rate Card, will be sent Free, on application.*

---

Send \$2 and receive it twice a month, postage paid, for one year.

---

ADDRESS,

CANADIAN MANUFACTURER,

6 WELLINGTON STREET WEST

TORONTO, ONTARIO, CANADA.

# THOMPSON & CO.,

SHERBROOKE, QUE.,

MANUFACTURERS OF

## BOBBINS AND SPOOLS

OF EVERY DESCRIPTION,

For Woolen, Cotton and Rope Mills.

Extra facilities for supplying new mills and filling large orders.

CORRESPONDENCE SOLICITED.

ORDERS PROMPTLY FILLED.

# SUPERINTENDENTS COTTON, WOOL AND WORSTED MILLS.

The Third edition of "THE RED BOOK" is ready. Get a copy of it and save money in buying your supplies. It places you in *direct* communication with *first hands*, thereby securing the advantages to be gained by *competitive prices*. Anything from a Ring Traveler to a Loom, Acetic Acid to Zinc Dust, Yarns of all kinds, Shoddy, Flocks, Cotton Buyers, Wool, New Devices, and Steam Appliances—in fact, everything needed for Cotton, Woolen and Worsted Mills, classified and indexed, compact and reliable. It also contains Yarn Tables, Cotton and Wool Products and amounts used each year from 1841 to date by Northern and Southern Mills, Exports, Statistics, Receipts and information of considerable value to mill men. Sent post-paid on receipt of price in cash or stamps (U.S. or Canadian).

ONE DOLLAR, Cloth. FIFTY CENTS, Paper.

ADDRESS—

J. E. PALMER, Publisher,

176 BROADWAY. NEW YORK.

# THOMAS C. KELLOGG,

SKANEATELES N.Y., U.S.A.,

Teasels are grown, Cured and Packed on own Premises.  
New York Office,  
100 & 102 Beade Street  
A. H. KELLOGG, Manager.

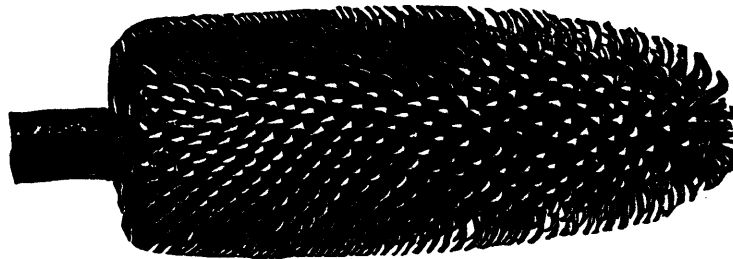

DEALERS IN  
AND  
CROWER OF  
AMERICAN Teasels.  
CLIPPED AND PACKED  
TO ANY  
DESIRED SIZE.

T. H. EATON & SON, Windsor, Ont., and Detroit, Mich., Agents for Ontario.

Correspondence Solicited.

WRITE FOR PRICE LIST NO. 71.

Samples sent by Mail upon Application.

# THE CHATHAM MANUFACTURING CO. (Ltd.)

MANUFACTURERS OF

HARDWOOD LUMBER,

SHIP PLANK AND



THE CHATHAM WAGON, Of which wagon the above is a faithful cut, and which the Govern ment of the Dominion of Canada has adopted as the STANDARD WAGON

We simply ask intending purchasers, in their own interests, to send to us for particulars of the Chatham Wagon, or if there is one convenient closely examine it before purchasing any other.

We also make Railway Platform Baggage Trucks, Farm and other Dump Carts, the Celebrated Main Bob Sleigh, the Patent Champion Hay Rack, etc., etc.

CORRESPONDENCE SOLICITED.

CHATHAM MANUFACTURING CO. (LIMITED).

**THE BELL  
Telephone Co'y**

OF CANADA.

—Manufacturers and Dealers in—

*Telegraph & Electrical*

INSTRUMENTS,

Electro-Medical Apparatus,

Fire Alarm Apparatus,

Magnets for Mills

Electrical Gas Lighting Apparatus,

Burglar Alarms,

Hotel and House Annunciators,

Electric Call Bells, &c., &c.

For further particulars apply to

No. 12 HOSPITAL STREET,

**MONTREAL.**

**DOMINION SHOW CASE  
MANUFACTURING CO'Y**

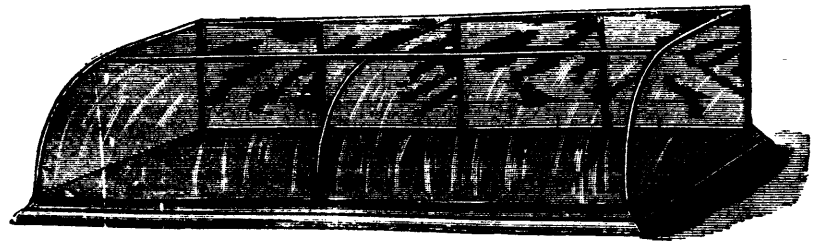

HIGHEST AWARDS

Received at

TORONTO EXHIBITION

1884, '85, and '86.

SEND FOR CATALOGUE AND  
PRICE LIST.

Show Cases, of Every Description in Nickel, Silver  
Walnut, Ebonized, Etc.

HARDWOOD STORE FITTINGS, METAL SASH BARS, ETC.

SHOWROOMS AND FACTORY:

40 Yonge Street, TORONTO, Ont.

Canada Tool Works,

**JOHN BERTRAM & SONS**

DUNDAS, ONT.

MANUFACTURERS OF

MACHINE TOOLS AND WOOD-WORKING

MACHINERY.

IN OUR LIST WILL BE FOUND THE FOLLOWING:

Lathes, Planers, Drills, Bolt Cutters, Punches and Shears, Boiler Rolls,  
Slotting, Milling and Cutting off Machines, Shafting Lathes, Pulley  
Turning and Boring Machines, Wood Planing and Matching  
Machines, Moulding, Mortising and Tenoning Machines,  
Band and Scroll Saws, Wood Turning Lathes, etc.

Complete Sets of Machinery for Locomotive and Car Works, Implement  
Works, Cabinet Factories, etc.

Write for prices of our New Acme Bolt Cutters, the best machine made.

Price Lists and Catalogues mailed on application.

Business established 1862.

**BELDING, PAUL & CO.**  
**SILK MANUFACTURERS**  
**MONTREAL.**

ORGANZINES, TRAMS,  
 SPUN SILK YARNS,

And all Threads for Manufacturing Pur-  
 poses made to order.

Correspondence Solicited.

**THE WELLINGTON MILLS**  
**LONDON**

**GENUINE EMERY**

OAKEY'S Flexible Twilled Emery Cloth.  
 OAKEY'S Flint Paper and Glass Paper.  
 OAKEY'S Emery Paper, Black Lead, &c., &c.

PRIZE MEDAL AND HIGHEST AWARD, PHILADELPHIA, 1876.  
 For Superiority of Quality, Skillful Manufacture, Sharpness,  
 Durability, and Uniformity of Grain.

Manufacturers: JOHN OAKEY & SONS, Wellington Mills,  
 WESTMINSTER BRIDGE ROAD, LONDON, ENGLAND.

Enquiries should be addressed to

JOHN FORMAN, 467, ST. PAUL ST., MONTREAL.

**CANTLIE, EWAN & CO.**

General Merchants and Manufacturers' Agents.

BLEACHED SHIRTINGS,  
 GREY SHEETINGS, TICKINGS,

WHITE, GREY AND COLORED BLANKETS,  
 FINE AND MEDIUM TWEEDS, KNITTED GOODS,  
 PLAIN AND FANCY FLANNEL,  
 LOW TWEEDS, ETOFFES, ETC.

Wholesale Trade Only Supplied.

15 VICTORIA SQUARE,  
 MONTREAL.

20 WELLINGTON ST. E.  
 TORONTO.

**PATENT BOILER WATER PURIFIER.**

NO PURGER  
 USED.  
 HEAT ALONE  
 DOES IT.

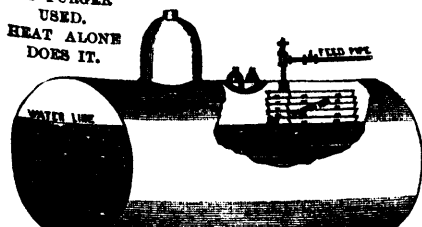

SHOWING POSITION OF PURIFIER IN BOILER.

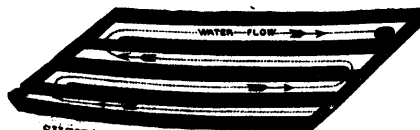

SHOWING ONE OF THE PANS OF PURIFIER.

THIS PURIFIER ENTIRELY PREVENTS THE FORMATION OF SCALE UPON SHELL AND FLUES OF ANY BOILER IN WHICH IT IS USED. ALL IMPURITIES ARE EXTRACTED FROM THE WATER BEFORE IT REACHES THE WATER LINE, AND ARE DEPOSITED IN THE PANS OF THE PURIFIER.

THESE PANS CAN BE REMOVED, CLEANED AND REPLACED WITH VERY LITTLE TROUBLE, AND IN A VERY SHORT TIME, WITHOUT EMPTYING THE BOILER OF HOT WATER, WHICH MEANS A SAVING OF TIME, LABOR AND FUEL.

FOR PARTICULARS AND PRICES ADDRESS

J. W. HERMAN, 114 1/2 King St. West, Toronto, Ont.

Authorized Capital and other Assets over  
**5,000,000.**

**MANUFACTURERS' LIFE INSURANCE COMPANY**

— AND —

**Manufacturers' Accident Insurance Company**

ISSUE ALL KINDS OF LIFE AND ACCIDENT POLICIES  
 AT THE LOWEST POSSIBLE RATES.

Special advantages are given Manufacturers' to indemnify  
 themselves against the

"Workmen's Compensation for Injuries Act."

SIR JOHN A. MACDONALD, P.C., G.C.B. . . . . PRESIDENT.

SIR ALEX. CAMPBELL, K.C.M.G. }  
 GEORGE GOODERHAM, Esq. } . . . . . VICE-PRESIDENTS.  
 WILLIAM BELL, Esq. }

J. B. CARLISLE,  
 Managing Director.

**38 KING STREET EAST,**  
**TORONTO, ONT.**

PERFECT THREADS AT ONE CUT.

**Reece's New Screw Plates.**

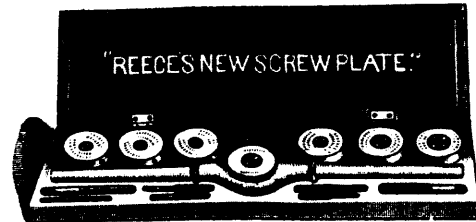

CUT SHOWING SIZE C COMPLETE IN BOX.  
 Size C cuts 1/2, 5-16, 3/8, 7-16, 1/2, 5/8 and 3/4 inch.  
 Price, complete, \$20.

SIZE A, SAME STYLE.  
 Cuts 1/2, 5-16, 3/8, 7-16 and 1/2 inch.  
 Price, complete, \$15.

SIZE B, SAME STYLE.  
 Cuts 1/2, 5/8, 3/4 and 1 inch.  
 Price, complete, \$21.

SIZE D, SAME STYLE.  
 Cuts 3/8, 7-16, 1/2, 5/8, 3/4 and 1 inch.  
 Price, complete, \$25.

SIZE E, SAME STYLE.  
 Cuts 1/2, 5-16, 3/8, 7-16, 1/2, 5/8, 3/4 and 1 inch.  
 Price, complete in box, \$29.

ALL OTHER DIES AT CORRESPONDING PRICES.

We furnish Collet and Die same as used in our Reece's New Screw Plate, to fit stocks B, D and large C stock, Little Giant, also B and C Wiley & Russell Lightning Screw Plate.

THE BEST PLATE IN THE WORLD.

MANUFACTURED BY

**BUTTERFIELD & CO.,**

Derby Line, Vermont, and Rock Island, Quebec.

PATENTED IN CANADA, JULY 2, 1885.

PATENTED IN UNITED STATES, JUNE 23, 1885.

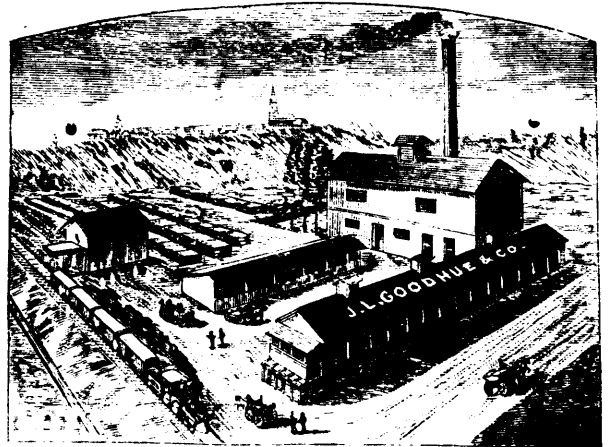
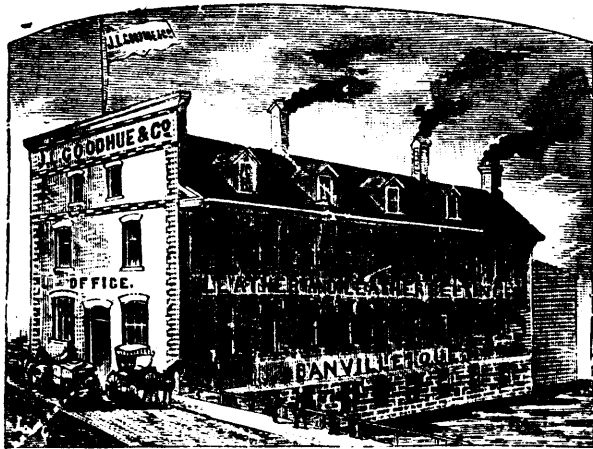

**J. L. GOODHUE & CO.**

ORDERS PROMPTLY FILLED. **LEATHER BELTING** WRITE FOR PRICES.

\* DANVILLE, P. QUE. \*

**GALT MACHINE KNIFE WORKS.**

PLANING MACHINE  
KNIVES.



STAVE CUTTER KNIVES.



STAVE JOINTER KNIVES.

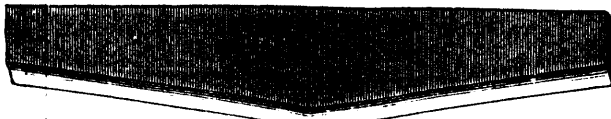

MOULDING, TENONING,  
MITREING,  
SHINGLE JOINTER,  
And other irregular shapes.

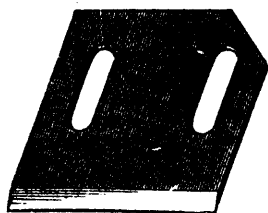

Cheese-box and Veneer, Paper Cutting, Leather Splitting and any special knife made to order. SEND FOR PRICE LIST. ALL WORK WARRANTED.

PETER HAY, GALT ONT.

**Millers' and Manufacturers' INSURANCE COMPANY.**

STOCK AND MUTUAL OBJECTS.

1. To prevent by all possible means the occurrence of avoidable fires.
2. To obviate heavy losses from the fires that are unavoidable by the nature of the work done in mills and factories.
3. To reduce the cost of insurance to the lowest point consistent with the safe conduct of the business.

**METHODS.**

All risks will be inspected by a competent officer of the company, who will make such suggestions as to improvements required for safety against fires, as may be for the mutual interests of all concerned.

Much dependence will be placed upon the obligation of members to keep up such a system of discipline, order, and cleanliness in the premises insured as will conduce to safety.

As no agents are employed and the company deals only with the principals of the establishments insured by it, conditions and exceptions which are so apt to mislead the insured and promote controversy and litigation in the settlement of losses will thus be avoided.

The most perfect method of insurance must, in the nature of things, be one in which the self-interest of the insured and the underwriters are identical, and this has been the object aimed at by the organizers of this company.

**W. H. HOWLAND, Vice-President.** **JAMES GOLDIE, President.**  
**HUGH SCOTT, Managing Director.**

Applicants for Insurance and other information desired, please address **MILLERS' AND MANUFACTURERS' INSURANCE COMPANY** No. 24 Church Street, Toronto.

# MACHINE BRUSHES

All kinds, Made to Order.

Highest Quality of Work Guaranteed.

Send full particulars of Dimensions and Quality when ordering.

OLD ROLLERS OR BLOCKS RE-FILLED WITH SPECIAL CARE.

## CHAS. BOECKH & SONS,

MANUFACTURERS.

Office and Warerooms :

Factory :

80 YORK STREET. | 142 to 150 Adelaide St. West.  
TORONTO, CANADA.



## NOTICE.

A NUMBER of School Sections in the Province of Manitoba will be offered for sale at public auction at the following places, on the undermentioned dates, viz :—

At *Manitou* on the 10th January, 1888; at *Winnipeg* on the 17th January, 1888; at *Portage la Prairie* on the 24th January, 1888; at *Brandon* on the 31st January, 1888; at *Minnedosa* on the 7th February, 1888.

In any case in which a settler on any quarter section of land included in the list referred to can prove to the satisfaction of the Commissioner of Dominion Lands that he was *bona fide* residing upon and cultivating the said quarter section, in ignorance of the law, on the 1st day of October, 1887, the purchaser of the quarter section, if he be other than the said settler, will be required to pay, for the benefit of the said settler, the value of the improvements thereon.

Lists of the lands to be sold, the upset price of each parcel, the terms of sale, and any other information which intending purchasers may desire to obtain may be had on application to the Secretary of the Department of the Interior, Ottawa; to the Commissioner of Dominion Lands, Winnipeg; or to any Agent of Dominion Lands in Manitoba or the North-West Territories.

A. M. BURGESS,  
Deputy of the Minister of the Interior.

No unauthorized insertion of this advertisement will be paid for.

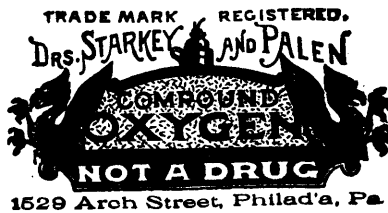

## A Well Tried Treatment

FOR

Consumption, Asthma, Bronchitis, Dyspepsia, Catarrh, Hay Fever, Headache, Debility, Rheumatism, Neuralgia and all Chronic and Nervous Disorders.

"The Compound Oxygen Treatment," Drs. Starkey & Palen, No. 1529 Arch Street, Philadelphia, have been using for the last seventeen years, is a scientific adjustment of the elements of Oxygen and Nitrogen magnetized, and the compound is so condensed and made portable that it is sent all over the world.

DRS. STARKEY & PALEN have the liberty to refer to the following named well-known persons who have tried their Treatment :

Hon. Wm. D. Kelley, Member of Congress, Philadelphia; Rev. Victor L. Conrad, Editor "Lutheran Observer," Philadelphia; Rev. Charles W. Cushlog, D.D., Rochester, N. Y.; Hon. Wm. Penn Nixon, Editor "Inter-Ocean," Chicago, Ill.; Rev. A. W. Moore, Editor "The Centenary," Lancaster, S.C.; W. H. Worthington, Editor "New South," Birmingham, Ala.; Judge H. P. Vrooman, Quenemo, Kan.; Mrs. Mary A. Livermore, Melrose, Mass.; Judge R. S. Voorhees, New York City; Mr. F. C. Knight, Philadelphia; Mr. Frank Siddall, Merchaut, Philadelphia; Hon. W. W. Schuyler, Easton, Pa.; Edward L. Wilson, 833 Broadway, N. Y.; Editor Philadelphia "Photographer"; Fidelia M. Lyon, Waimea, Hawaii, Sandwich Islands; Alexander Ritchie, Inverness, Scotland; Mrs. Manuel V. Ortega, Fresnillo, Zacatecas, Mexico; Mrs. Emma Cooper, Uvilla, Spanish Honduras, Central America; J. C. bb, U.S. Vice-Consul, Casablanca, Morocco; M. V. Ashbrook, Red Bluff, Cal.; Ernest Turner, Nottingham, England; Jacob Ward, Bowral, New South Wales, and thousands of others in every part of the world.

"Compound Oxygen—its Mode of Action and Results," is the title of a new brochure of two hundred pages, published by Drs. Starkey & Palen No. 1529 Arch St., Philadelphia, Pa., which gives to all inquirers full information as to this remarkable curative agent, and a record of several hundred surprising cures in a wide range of chronic cases—many of them after being abandoned to die by other physicians. Will be mailed free to any address on application by addressing

E. W. D. KING,  
58 Church St., Toronto, Ont.

# BELL ORGANS

FOR  
Chapel,  
Church,  
Lodge,  
Parlor.

## ARE THE BEST

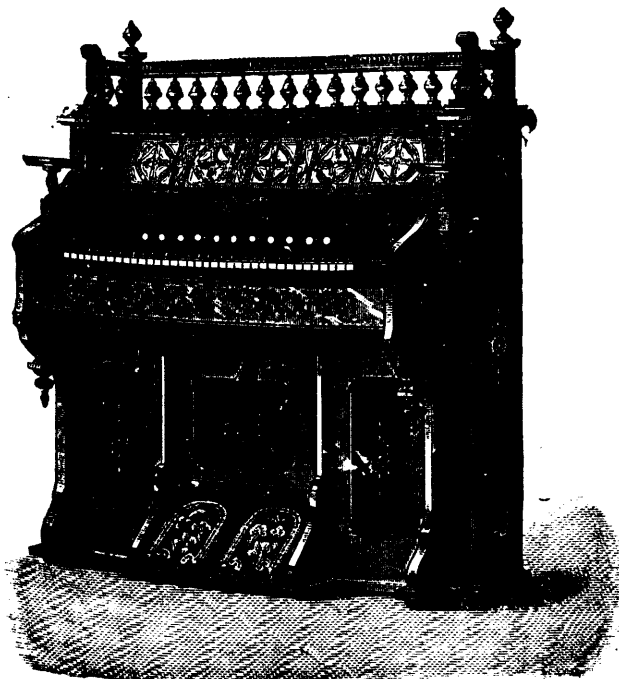

OUR Large Double and Single Manual Organs are the best in the Market, and Musicians should see them before buying elsewhere.

CATALOGUES  
SENT ON APPLICATION

W. BELL & CO.,  
GUELPH, CANADA.



## Industrial and Trade DIRECTORY.

### Acids and Aniline Dyes.

THEO. H. EATON & SON, Windsor, Ont.; Detroit, U.S.A.—Importers. Every Description **Pure Aniline Dyes** for Cotton and Woollen Manufacturers. **Dyed Samples** furnished on application. Address all correspondence to Head Office, Detroit, Mich.

### Agricultural Implements.

A. S. WHITING MANUFACTURING CO., Cedar Dale, Ont.—Manufacturers of scythes, forks, hoes, etc.

WELLAND VALE MANUFACTURING CO.—Lock No. 2, St. Catharines, Ont., Canada—Manufacturers of axes, scythes, forks, hoes, rakes and edge tools.

### Bobbins and Spools

THOMPSON & CO., Sherbrooke, P. Q.—Manufacturers of all kinds of Bobbins and Spools for Cotton and Woollen Mills—Special patterns made to order from sample.

### Bridge Builders.

DOMINION BRIDGE CO. (Limited).—Shops at Toronto, Ontario, and Lachine, Quebec. Builders of Steel and Iron Railway and Highway Bridges.

### Chemicals.

DOMINION DYEWOOD AND CHEMICAL CO., Toronto.—Importers and Manufacturers. Chemicals for Cotton, Woollen, Paper and Leather Manufacturers.

MCARTHUR, CORNEILLE & CO. (successors to John McArthur & Son), Montreal.—Offer at closest figures chemicals required by soap-boilers, oil refiners, paper-makers, and by manufacturers of woollens, cottons, leather, &c.

### Cotton Mills.

HAMILTON COTTON MILLS CO., Hamilton.—Denims, tickings and yarns.

### Dyes, Dyeing Drugs and Extracts.

THEO. H. EATON & SON, Windsor, Ont.; Detroit, U.S.A.—Carry full line of Pure Dyeing Drugs, Dye Woods and Extracts adapted for the requirements of Woollen and Cotton Manufacturers. **Paper Makers' Anilines** and Chemicals. Address the **Detroit Office**.

### Dye Stuffs.

MCARTHUR, CORNEILLE & CO. (successors to John McArthur & Son), Montreal.—Supply of best quality at closest prices. Every description of coloring materials required by manufacturers of woollens, cottons, silks, paper, leather, &c. Are sole agents in Canada for the celebrated aniline dyes of A. Porrier, Paris.

LYMAN BROTHERS & CO., Nos. 71 and 73 Front Street East, Toronto—Dye Stuffs of all kinds for Woollen and Cotton Manufacturers; Warps, Shuttles, Bobbins, Card Clothing, etc., etc.

### Dyewood and Dye Stuffs, Aniline Dyes.

DOMINION DYEWOOD AND CHEMICAL CO., Manufacturers.—Pure Dyewoods, Dyeing Drugs. Sole Agents. English, German, and French Aniline Dyes, for Woollen, Silk Paper, and Leather manufactures.

### Edge Tools.

WELLAND VALE MANUFACTURING CO.—Lock No. 2, St. Catharines, Ontario, Canada.—Manufacturers of axes, scythes, forks, hoes, rakes and edge tools.

### Emery Wheels.

HART EMERY WHEEL CO., Hamilton.—Manufacturers of every description of Emery Wheels and Emery Wheel machinery.

### Gas Engines.

JOHN DOTY, Toronto.—Manufacturer in Canada of the new "Otto" silent gas engine, two, four, and seven horse power and larger.

### Glove Manufacturers.

W. H. STOREY & SON, Acton, Ont.—Manufacturers of fine gloves and mitts in every variety and style.

### Hoist and Elevator Manufacturers.

LEITCH & TURNBULL, Canada Elevator Works, cor. Queen and Peter Streets, Hamilton, Ont.—Patent Safety Hydraulic, Hand, and Power Elevators. Telephone connection.

### Hubs, Spokes and Bent Goods.

F. W. HORE & SON, Hamilton, Ont.—Manufacturers of wheels, wheel material, shafts, poles, etc.

COWAN & CO., Galt.—Manufacturers of every description of wood working machinery.

H. R. IVES & CO., Montreal.—Hardware manufacturers and founders; iron railing and ornamental iron work a specialty.

JOHN BERTRAM & SONS, Dundas.—Machine tools and wood working machinery. Toronto wareroom, 58 Yonge St. Agents—The Polson Iron Works Co.

Montreal wareroom, Craig St. Agents for Quebec—The Machinery Supply Association, Montreal.

THE OSHAWA MALLEABLE IRON CO., Oshawa, Ont.—Manufacturers of malleable iron castings, to order, for all kinds of Agricultural Implements and miscellaneous purposes.

SMITH'S FALLS MALLEABLE IRON WORKS, Smith's Falls, Ont.—Manufacturers to order of refined malleable iron castings from air furnace. Agricultural and other heavy castings a specialty. Carriage castings in stock.

### Engines and Boilers.

JOHN DOTY, Toronto.—Engines and boilers of every description and capacity, also shafting, pulleys, and hangers for factories.

### Knife Works.

THE WHITMAN & BARNES MANUFACTURING CO., St. Catharines, Ont.—Manufacturers of mowing and reaping machine knives, sections, guard plates, cutting apparatus complete, spring keys and cutters, etc.

### Knitting Mills

S. LENNARD & SONS, Dundas.—Manufacturers of plain and fancy hosiery.

### Manufacturers' Supplies.

E. JENCKES MANUFACTURING CO., Pawtucket, R. I.—Sole manufacturers of Hicks Improved U. S. Standard Ring Travellers. Belt hooks, gimlet pointed wire goods, spinning rings, cotton banding, twine, &c. Manufacturers' supplies. Leather belting and lace leather. Special agents for Jos. Noone's sons cloths.

### Oils.

MCARTHUR, CORNEILLE & Co (successors to John McArthur & Son), Montreal.—Afford best value in pure olive and lard oils, also in all other leading lines of vegetable, animal, and mineral oils for factory use. Invite special attention to their celebrated crown diamond "engine" and "machinery" oils.

### Paper Manufacturers.

WM. BARBER & BROS., Georgetown—Manufacturer of book and fine papers.

THE TORONTO PAPER MANUFACTURING CO., Cornwall, Ont.—Manufacturers of engine sized superfine papers, white and tinted book papers, blue and cream laid and wove foolscaps, account book, envelope and lithographic papers, etc., etc.

### Saw Manufacturers.

R. H. SMITH & CO., St. Catharines.—Manufacturers of all kinds of saws, plastering trowels, straw knives, etc. Sole manufacturers for the Dominion of Canada of the celebrated "Simond's Saw."

### Scythe Snaths.

THE DOMINION SNATH COMPANY, Sherbrooke, Que.—Manufacturers of Patent Swing Socket, and every variety of Scythe snath.

### Tanners' and Wool Pullers' Supplies.

THEO. H. EATON & SON, Windsor, Ont.; Detroit, U.S.A.—Supply at lowest prices all Chemicals used by Tanners and Wool Pullers. Special Anilines for Sheep Skin Dyers, Wool Mat Manufacturers, etc., etc. Address correspondence to Head Office, Detroit, Mich.

### Taps and Dies.

BUTTERFIELD & CO., Rock Island, P. Q.—Manufacturers of Taps, Dies, and all Screw Cutting Tools.—Telegraph Office, Derby Line, Vt.

### Wire Works.

B. GREENING & CO., Hamilton, Ont.—Manufacturers of wire ropes, cloth and general wire workers.

TIMOTHY GREENING & SONS, Dundas, Ont.—Manufacturers of the strongest description of steel wire cloth, malt kiln floors and general wire weavers. Telephone connection.

## PATENTS

MUNN & CO., of the SCIENTIFIC AMERICAN, continue to act as Solicitors for Patents, Caveats, Trade Marks, Copyrights, for the United States, Canada, England, France, Germany, etc. Hand Book about Patents sent free. Thirty-seven years experience.

Patents obtained through MUNN & CO. are noticed in the SCIENTIFIC AMERICAN, the largest, best and most widely circulated scientific paper. \$3.00 a year. Weekly. Splendid engravings and interesting information. Specimen copy of the SCIENTIFIC AMERICAN sent free. Address MUNN & CO., SCIENTIFIC AMERICAN Office, 361 Broadway, New York.

## TO ADVERTISERS!

For a check for \$2, we will print a ten-line advertisement in One Million issues of leading American Newspapers and complete the work within ten days. This is at the rate of only one-fifth of a cent a line, for 1,000 circulation! The advertisement will appear in but a single issue of any paper, and consequently will be placed before One Million different newspaper purchasers;—or FIVE MILLION READERS, if it is true, as is sometimes stated, that every newspaper is looked at by five persons on an average. Ten lines will accommodate about 75 words. Address with copy of Adv. and check, or send 20 cents for Book of 272 pages. GEO. P. ROWELL & CO., 10 SPRUCE ST., NEW YORK.

We have just issued a new edition (the 165th) of our Book called "Newspaper Advertising." It has 272 pages, and among its contents may be named the following Lists and Catalogues of Newspapers:—

DAILY NEWSPAPERS IN NEW YORK CITY, with their Advertising Rates.  
DAILY NEWSPAPERS IN CITIES HAVING MORE THAN 150,000 POPULATION, omitting all but the best.  
DAILY NEWSPAPERS IN CITIES HAVING MORE THAN 20,000 POPULATION, omitting all but the best.

A SMALL LIST OF NEWSPAPERS IN WHICH TO ADVERTISE every section of the country; being a choice selection made up with great care, guided by long experience.

ONE NEWSPAPER IN A STATE. The best one for an advertiser to use if he will use but one.  
BARGAINS IN ADVERTISING IN DAILY Newspapers in many principal cities and towns, a List which offers peculiar inducements to some advertisers.

LARGEST CIRCULATIONS. A complete list of all American papers issuing regularly more than 25,000 copies.

THE BEST LIST OF LOCAL NEWSPAPERS, covering every town of over 5,000 population and every important county seat.

SELECT LIST OF LOCAL NEWSPAPERS, in which advertisements are inserted at half price.

547 VILLAGE NEWSPAPERS in which advertisements are inserted for \$41.40 a line and appear in the whole lot—one-half of all the American Weeklies.

Sent to any address for THIRTY CENTS.



# THE GALT FOUNDRY,

## Engine and Machine Works.

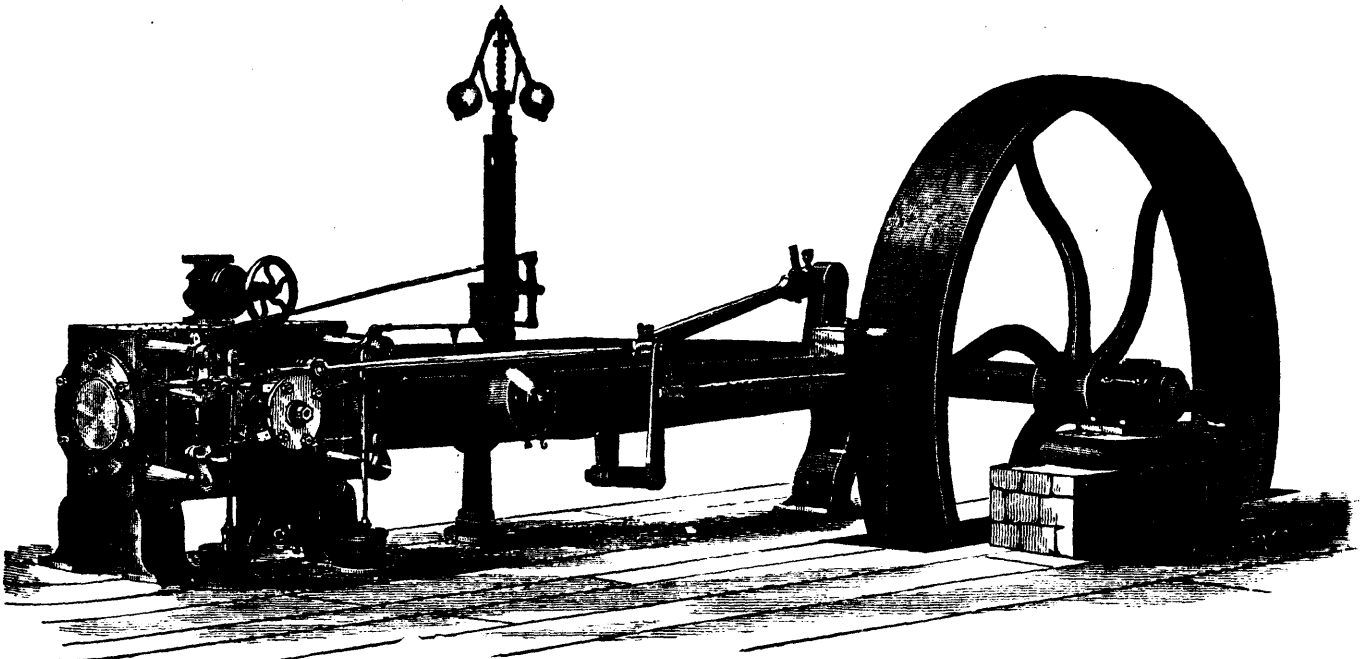

## THE HARRIS-CORLISS STEAM ENGINE

Is the most perfect Cut-off Engine made. For Economy of Fuel, Regulating of Speed, Accessibility of all its Parts, it has many Imitators, but no Equals, and is Unsurpassed.

While many Engines of the same class have been invented, built, tried and abandoned, the Harris-Corliss has steadily gained in public favor, and is now

**Without a Successful Rival.**

### PLEASE NOTICE SOME OF THE ADVANTAGES OF THE HARRIS-CORLISS ENGINE :

- 1st—The steam is admitted at Boiler pressure to the piston by the main valve and is cut off at the same point, the load determining through the regulator, when the supply of steam shall be cut off. This is the only Engine that thus admits steam at full boiler pressure.
  - 2nd—The success of the Harris-Corliss Engine lies in the simplicity and precise action of the governing elements; the Governor is an independent mechanism, with no extraneous load, and free to instantly respond to all variations in the angular velocity of rotating parts.
  - 3rd—No parts of the regulating medium enter the steam chest and thereby be out of sight of the engineer, and subject to the corrosive action of steam and the oil used for lubricating the valves and piston.
  - 4th—Regularity of Speed under varying loads of steam pressure.
  - 5th—Recessed Valve Seats which avoid the liability of wearing shoulders on them.
  - 6th—Stop Motion on Regulator of Engine which effectually stops the Engine whenever the regulator by any means fails to perform its work, thus preventing the Engine from running away.
  - 7th—Having four Valves either can be adjusted independently of the other with the greatest ease.
  - 8th—The increased amount of power it develops.
- We would draw special attention to our new and improved Adjustable Pillow Block, which is pronounced by all practical men who have seen it, to be the very best in Canada.

## COWAN & CO.,

Galt, Ont., Canada.

Manufacturers of Engines, Boilers and Wood-Working Machinery—all kinds, new Patterns, highly finished.



**Notice to Contractors.**  
**SAULT SAINTE MARIE CANAL.**

CONTRACTORS intending to tender for works of construction of the canal proposed to be formed on the Canadian side of the Sainte Mary's River, are hereby informed that tenders will be received about **January next**, and that the most favorable time to examine the locality will be between the present time and the early part of November next.

When plans, specifications and other documents are prepared, due notice will be given. Contractors will then have an opportunity of examining them and be furnished with blank forms of tender, etc.

By order,

**A. P. BRADLEY,**  
Secretary.

Department of Railways and Canals,  
Ottawa, 24th August, 1887.

**Maw & McFarlane**  
**DUNDAS, ONT.**

**IRON FOUNDERS, ENGINEERS AND MACHINISTS,**

MANUFACTURERS OF

**Drop Hammers,**  
LIFTERS, DIE SINKERS AND PRESSES.

**CORRESPONDENCE SOLICITED.**

**TORONTO LITHOGRAPHING CO.**  
Globe Building, Toronto

MAKE A SPECIALTY OF  
**Fine Color Work**  
CHROMO ADVERTISING  
CARDS and NOVELTIES  
also do a Superior Class of Wood Engraving

**VICTORIA WIRE MILLS.**

ESTABLISHED 1859.

**BANK**  
AND  
**OFFICE**

Counter Railings

IN

Brass & Iron.

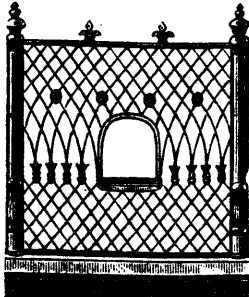

**WIRE**  
Window Guards  
AND  
Fine Wire Blinds  
FOR  
Inside Windows.

MANUFACTURED BY

**B. GREENING & CO., Hamilton, Ont.**

Send for Catalogue.

**HAMILTON**  
**COTTON COMPANY,**

MANUFACTURERS OF

**THE STAR BRAND**

COTTONADES, DENIMS, TICKINGS.

**Star Brand—BEAM WARP.**

" HOSIERY YARN

" BUNDLE YARN.

" CARPET WARP.

" BALLED KNITTING YARN.

First Prize, Silver Medals, for Beam Warps and Denims  
Toronto, 1881.

General Agents,—

**F. McELDERY & CO.,**

204 MCGILL STREET, MONTREAL.

22 & 24 COLBORNE ST., TORONTO.

**BEAVER LINE.**

The Canada Shipping Co.'s Line of Steamers.

BETWEEN

**MONTREAL AND LIVERPOOL.**

Comprising the following First-Class Clyde-built, Full-powered Iron Steamships:

	Tons.
LAKE ONTARIO, Capt. Wm. Bernson .....	5,300
LAKE SUPERIOR, Capt. Wm. Stewart .....	5,000
LAKE HURON, Capt. H. Campbell .....	4,100
LAKE WINNIPEG, Capt. M. L. Trautman .....	3,300
LAKE NEPIGON, Capt. P. D. Murray .....	2,300

**WINTER ARRANGEMENTS.**

The steamers of the Line will sail from LIVERPOOL for New York (calling at Boston to land Canada in Through Cargo) as follows:—

Lake Superior .....	Thursday, Nov. 24
Lake Ontario .....	" Dec. 8
Lake Huron .....	" Jan. 22

**FROM NEW YORK FOR LIVERPOOL DIRECT.**

Lake Superior .....	Thursday, Dec. 15
Lake Ontario .....	" 29
Lake Huron .....	" Jan. 12

And fortnightly thereafter during the Winter season.

These steamers are built in water-tight compartments, and of special strength for the North Atlantic trade.

In the passenger departments the most perfect provision has been made to ensure the comfort and convenience of all. In the Cabin the State-rooms are large and airy. The Steerage is fitted with the most approved Patent Canvas Berths, and is fully ventilated and heated by steam.

An experienced Surgeon is carried by each steamer, also Stewardesses to attend to the wants of females and children.

**RATES OF PASSAGE:**

MONTREAL TO LIVERPOOL:

Saloon, \$57.50. Intermediate, \$37.50. Steerage, \$27.50.

For Freight and other particulars, apply: In Belfast, to A. A. WATT, 3 Custom House Square; in Queenstown, to N. G. SHYMOUR & Co.; in Liverpool, to R. W. ROBERTS, 21 Water St.; in New York to JAS. ARKELL & Co., Kemble Building; in Boston to J. B. BRIGHAM & Co., 38 Central Street.

**H. E. MURRAY,**

General Manager,

1 Custom House Square, Montreal.

**Cobban Manufacturing Co'y** Factory & Head Office: Toronto.  
 Branch: 455 St. Paul Street, Montreal.

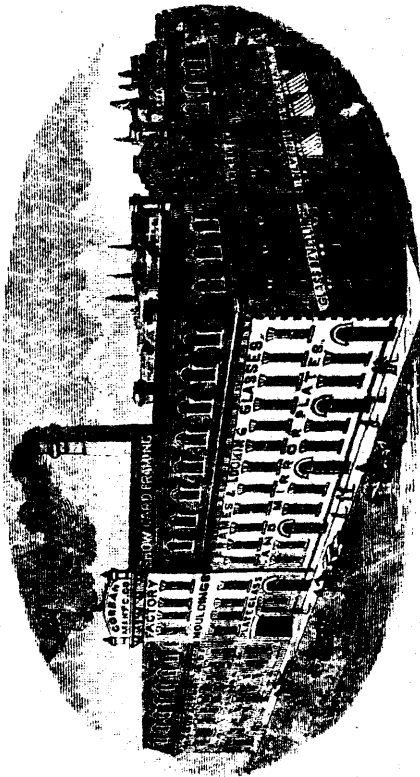

MANUFACTURERS OF  
 Mantles, Over Mantles and Mirrors in Finest Hardwoods. Mouldings, Picture  
 Frames and Looking Glasses. Mirror Plates: British, French, German,  
 Shocks. Plate Glass Beveling and Silvering a Specialty.

CLOSE PRICES. LIBERAL TERMS.  
 MONTREAL. TORONTO.

**ONTARIO BOLT CO., TORONTO,**

MANUFACTURE

- Threshing Machine Teeth,
- Machine Bolts,
- Bolt Ends and Blank Bolts,
- Bridge Rods and Bridge Rivets,
- Coach Screws and Skein Bolts,
- The Superb Carriage Bolt,
- The Prize Carriage Bolt,
- The Eclipse Carriage Bolt,
- The Prize Tire Bolt,
- The Eclipse Sleigh Shoe Bolt,
- The Prize Plough Bolt,
- Best Whiffletree Bolts,
- Best Shaft and Step Bolts,
- Best Eccentric Head Spring Bolts,
- Best Elevator Bolts,
- Best Norway Shackles Bolts,
- Best Railway Track Bolts,
- Black Iron Rivets,
- Boiler Rivets,
- Railway Spikes,
- Pressed Spikes,
- Hot Pressed Nuts,
- Bridge Bolts and Rag Bolts.

**HEINTZMAN & CO.**

MANUFACTURERS OF



GRAND,  
 SQUARE,  
 AND UPRIGHT  
**PIANOFORTES.**

SEND FOR ILLUSTRATED CATALOGUE.

Warerooms, - 117 King St. West,  
**TORONTO.**

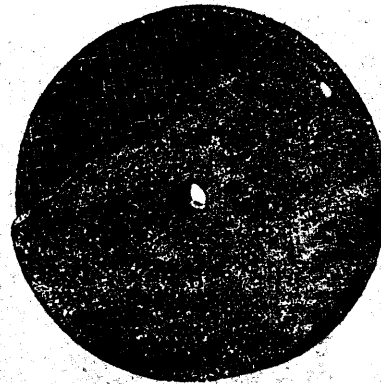

**HART**  
**Emery Wheel**  
 COMPANY  
 (LIMITED),  
 Hamilton, Canada.

MANUFACTURERS OF

**EMERY WHEELS**

FOR

FOUNDRIES, MACHINE SHOPS,  
 SAW MILLS, & PLANING MILLS  
 SEND FOR CIRCULAR.

Also  
 MANUFACTURERS  
 OF —

**EMERY WHEEL**  
**MACHINERY.**

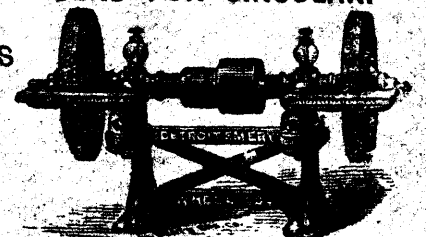

Illustrated Price List sent on Application.

**W. STAHLSCHMIDT & CO.**  
PRESTON, ONT.

MANUFACTURERS OF

School, Office, Church and Lodge  
Furniture.

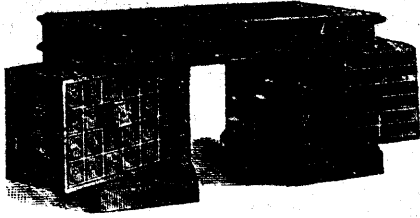

**ROTARY DESK**

No. 50.

Send for Circulars and Price List. Name this paper.

ESTABLISHED 1820.

**EAGLE FOUNDRY.**

**GEORGE BRUSH,**

14 TO 34 KING AND QUEEN STREETS, MONTREAL,

Maker of

STEAM ENGINES,  
STEAM BOILERS,  
HOISTING ENGINES,  
STEAM PUMPS,  
CIRCULAR SAW MILLS,  
BARK MILLS,  
SHINGLE MILLS,  
ORE CRUSHERS,  
MILL GEARING,  
SHAFTING,  
HANGERS AND  
PULLEYS.

HAND AND POWER HOISTS FOR  
WAREHOUSES, &c., &c.,

and Agent for

"Water's" Perfect Steam Engine Governor, and  
"Heald & Sisco's" Centrifugal Pumps.

**LANSDOWNE PIANO CO.**

**UPRIGHTS**  
— AND —  
**SQUARES**

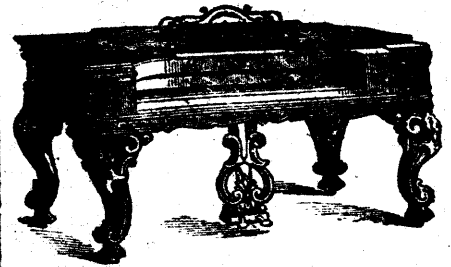

**The Leading Canadian Pianos**

STRICTLY FIRST-CLASS. Correspondence Solicited

**86 York St., Toronto.**

Established 1872.

**THE ACCIDENT**

INSURANCE CO. OF NORTH AMERICA.

NEW FEATURE,

**JOINT INSURANCE**

**FOR PARTNERSHIPS**

IMPORTANT TO MANUFACTURING FIRMS.

**MEDLAND & JONES,**

GENERAL AGENTS,

Corner Adelaide and Victoria Streets,

TORONTO.

**S. Lennard, Sons, & Bickford,**

DUNDAS, ONT.

PATENTERS OF THE "ELYSIAN" SEAMLESS HOSIERY,

Manufacturers of Plain and Fancy  
Hosiery, Caps, Ties, Sashes,  
etc., etc., etc.,

To the Wholesale Trade only.

Represented in Eastern Ontario, Que-  
bec, Nova Scotia and New Brunswick,  
by

**F. W. NEWMAN & CO.,**  
21 Lemoine St., Montreal.

In Manitoba by  
**PEDDIE & CO.,**  
WINNIPEG, MANITOBA.

In Western Ontario by  
**S. LENNARD,**  
Senior Member of the Firm.



EVERY REPUTABLE DEALER KEEPS  
THEM.

Insist on having the Genuine, and see  
that they bear our name.

**J. M. LAUGHLIN'S SONS.**

CROWERS  
MERCHANTS,  
AND EXPORTERS OF

SHINEATELES FALLS  
N.Y.

**AMERICAN TEASELS.**

